

**installation
and
operating
instructions
for model SX-43
radio receiver**

MARCH 1949

94X180

the hallicrafters co.

MANUFACTURERS OF RADIO AND ELECTRONIC EQUIPMENT, CHICAGO 24, U. S. A.

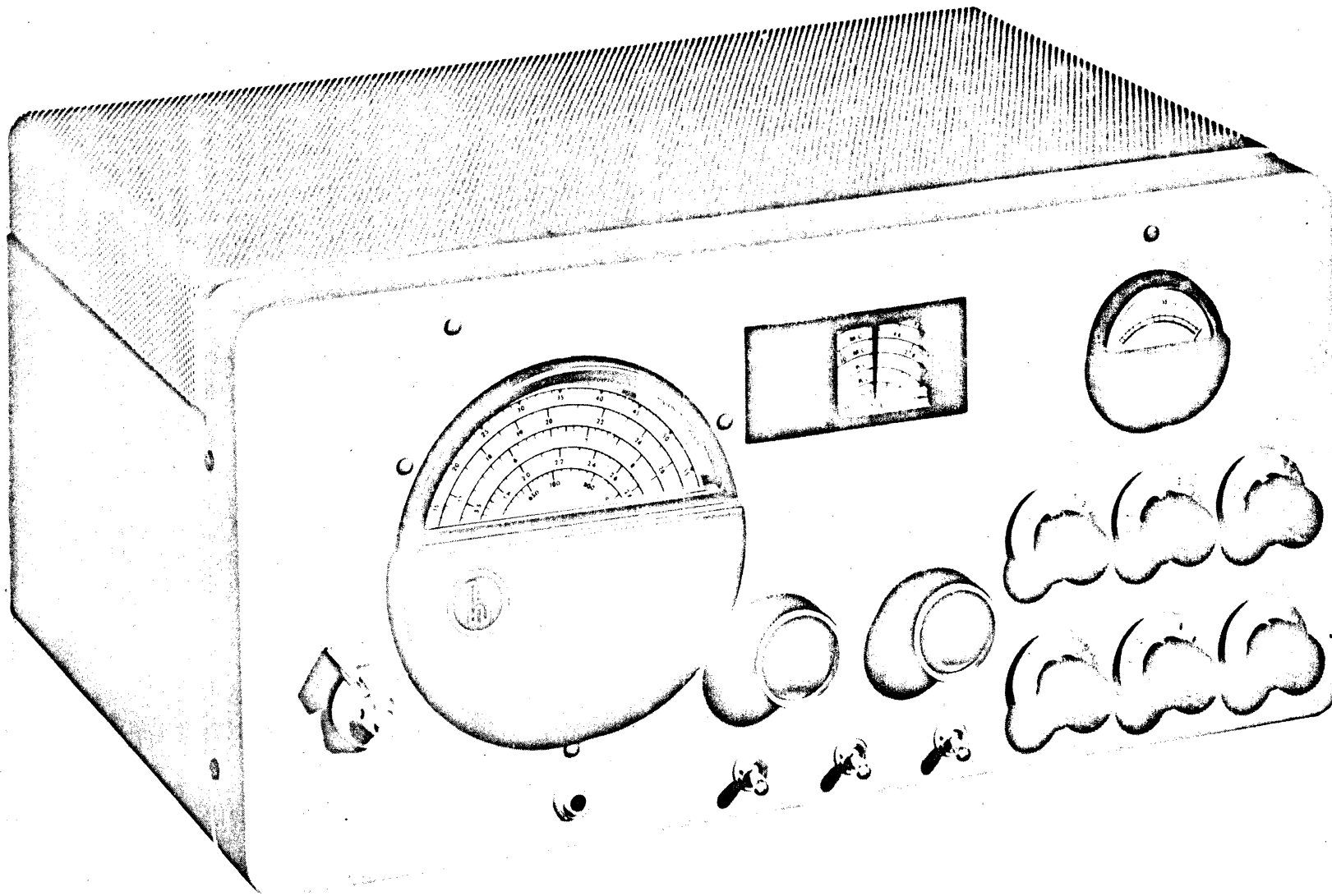

Figure 1. Model SX-43 Radio Receiver, front view

SIZE $18\frac{1}{2}$ " W X $13\frac{3}{4}$ " DEEP
WEIGHT 38. LBS

**INSTALLATION AND OPERATING INSTRUCTIONS FOR
RADIO RECEIVER MODEL SX-43
GENERAL INFORMATION**

I. INSTALLATION

It is recommended that, upon receipt, the carton and then the unpacked receiver be carefully examined for any damage which may have occurred during shipment. Should any damage be apparent, immediately file claim with the carrier, stating the extent of damage.

IMPORTANT. Unless otherwise marked, this receiver is operated from 105 to 125 volts 50-60 cycle a-c power. If in doubt call your local utility company for information.

Connect the R-42 Reproducer, or the R-44, as the case may be, to the 500 and "C" terminals on the SX-43.

Turn the VOLUME control to the left as far as possible. (See Fig. 2) This turns off the radio. Plug the power cord into the a-c outlet.

Attach an antenna (aerial) to the post marked A-1. This antenna wire should be, preferably, outdoors above surrounding structures and from 25 to 100 feet long. Attach a wire from a good ground to the post marked GND. In general the better the antenna system, the better the signal will be heard.

Having followed instructions to this point you are now ready to operate your receiver. Let's first tune in a-m (standard broadcast) stations.

2. GENERAL OPERATION

1. To turn the receiver on, the VOLUME control is turned to the right to about 4 on the knob scale. When the receiver is on, the dial scales and the meter will light up.
2. Turn the BAND SELECTOR knob left to the red dot. (See Fig. 3)
3. Set the three toggle switches to the "right" hand position. (See Fig. 4)
4. Set four of the six right-hand control knobs to the following positions: "SELECTIVITY" to red dot, "RECEPTION" to red dot, "SENSITIVITY" to 10, and "VOLUME" to 4 or the desired amount of volume. (See Fig. 5)

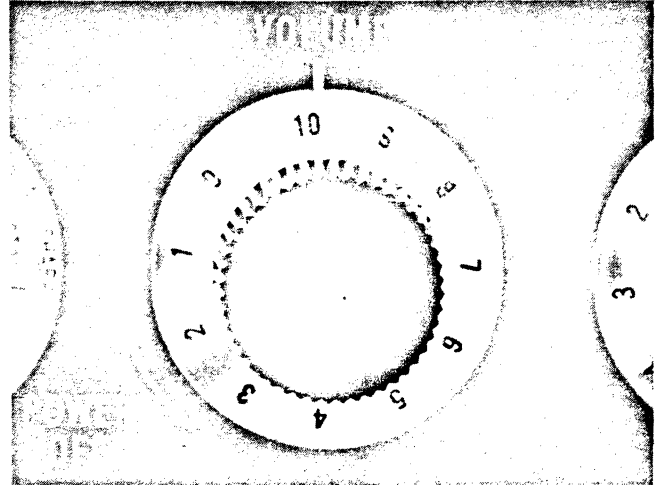

Figure 2. View showing Volume Control

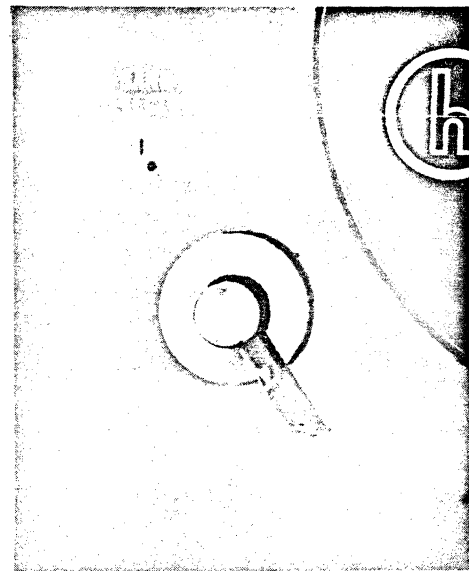

Figure 3. View showing Band Selector Switch

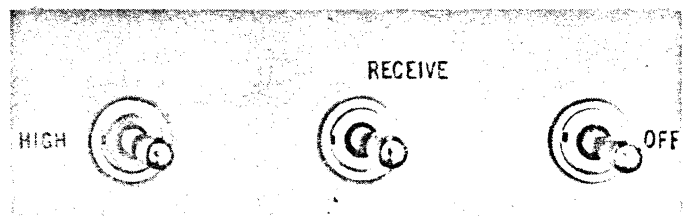

Figure 4. View showing three toggle switches

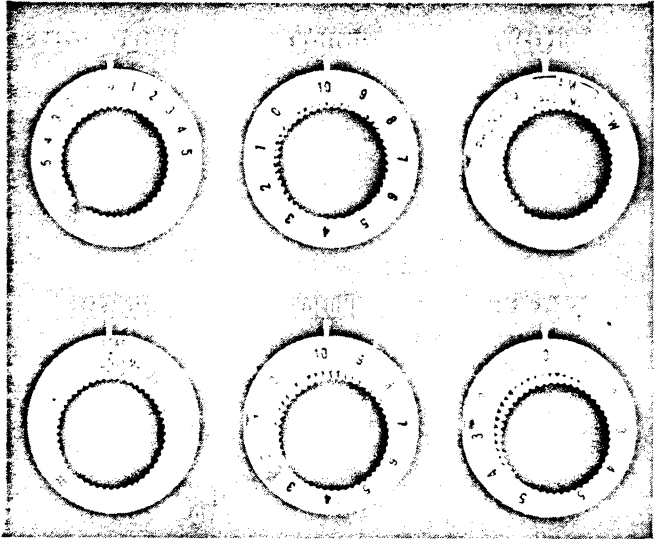

Figure 5. View showing six right hand controls

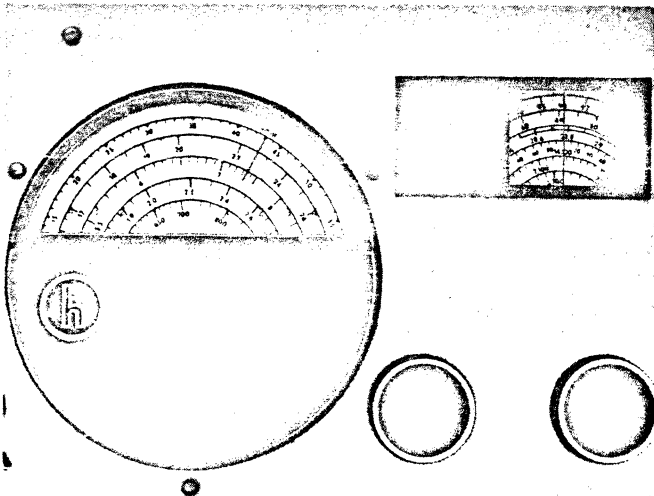

Figure 6. View showing Bandsread and Main Tuning Dials

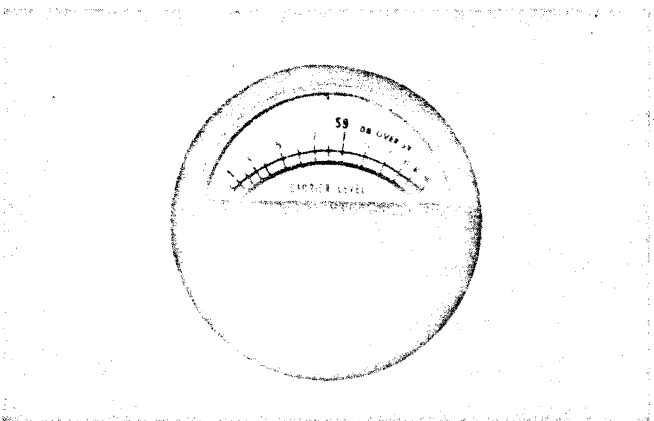

Figure 7. View showing Carrier Meter

5. Set the bandsread (fine tuning) dial to the high end of the dial, (counterclockwise).

6. The knobs for CRYSTAL PHASING, RECEPTION, CW PITCH, and SENSITIVITY should in all cases be left set at the red dot or "0".

7. Now tune in stations by tuning with the main control knob. (See Fig. 6) As the station is tuned in, the carrier meter needle (See Fig. 7) will move from the left side of the scale to the right. Carefully tune the receiver by causing the meter needle to move as far to the right as possible. At this point the receiver is properly tuned to the station.

8. To control the volume, adjust the VOLUME control (See Fig. 2) by turning it to the right for a louder signal or to the left for a softer signal.

9. The frequency calibration on the main tuning dial for the broadcast band is shown on the scale at the bottom of the dial. (See Fig. 6). This scale as all other scales is calibrated in kilocycles and tunes over the broadcast band from 540 to 1650 kc.

10. When the TONE switch is in the LOW position, the higher audio frequencies are attenuated. If a broad audio response is preferred, the TONE switch may be set at HIGH.

11. For normal reception the SELECTIVITY control is set at NORMAL BROAD. However, when tuning a weak station near to the frequency of a strong station, it will be easier to separate the two signals if the SELECTIVITY control is switched to the NORMAL SHARP position.

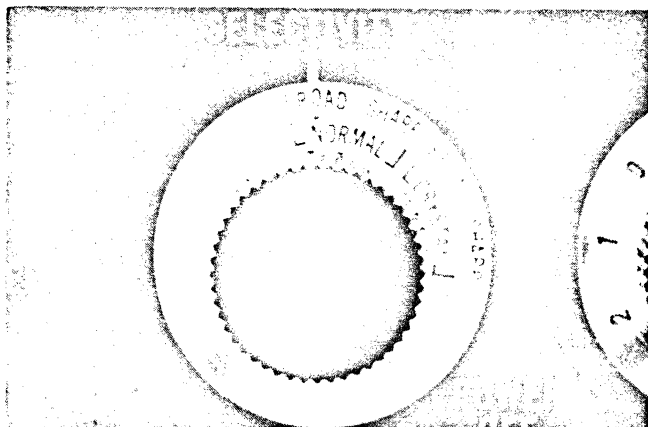

Figure 8. View showing Selectivity Control

3. FM RECEPTION

Thus far we have tuned the receiver for a-m reception. If it is desired to use it on f-m reception, all controls should be set as previously described with the exception of the following:

1. The RECEPTION knob should be switched to FM (green dot) and SELECTIVITY knob set at NORMAL BROAD. (green dot).
2. The BAND SELECTOR switch should be set on the green dot. This covers the band 86 to 109 mc.
3. Tune in f-m stations by turning the BAND SPREAD tuning knob. The band spread dial indicates the frequency of reception. Note that as the f-m station is tuned-in the carrier level meter pointer deflects to the right.

When meter pointer is at maximum deflection the station is tuned in.

The carrier level meter is calibrated to read relative signal strength. It also functions as a tuning indicator, the receiver being tuned to the desired signal with maximum deflection of the meter needle. When using the carrier level meter, the RECEPTION switch should be set to the red dot for AM reception or to the green dot for FM reception. The SENSITIVITY control must be set at 10 and the volume controlled with the VOLUME control.

4. SHORT WAVE RECEPTION

So far we have covered two bands of the receiver (Broadcast 540-1650kc), and the f-m band 86-109 mc.) For the other five bands of the set, operation is the same, the only difference being in the setting of the BAND SELECTOR switch knob, which may be turned to the desired band. On bands 5 and 6 tuning is done with the BAND SPREAD control as the general coverage dial is switched out of the circuit.

DETAILED AND TECHNICAL OPERATING INSTRUCTIONS

I. GENERAL

The Model SX-43 is a 11 tube superheterodyne radio receiver designed to provide amplitude modulated (AM) reception over the frequency range of 540 kc to 55 mc and frequency modulated (FM) reception over the frequency range of 44 to 55 mc and 86 to 109 mc bands. Calibrated bandspread is provided for the 80, 40, 20, and the 10 meter Amateur bands.

FREQUENCY COVERAGE

BAND	COVERAGE	TYPE OF RECEPTION
1	.540 to 1.65 mc	AM/CW
2	1.65 to 5.0 mc	AM/CW
3	5.0 to 15.1 mc	AM/CW
3A	13.9 to 14.4 mc	AM/CW
4	15.1 to 44.0 mc	AM/CW
5	44.0 to 55.0 mc	AM/FM
6	86.0 to 110 mc	FM

Adequate overlap is provided at ends of all bands.

The receiver as normally supplied is designed to operate from a 105 to 125 volts 50/60 cycle, single phase source of a-c power. These operating instructions also cover Universal Models which operate from a 105 to 250 volts, 25/60 cycle single phase a-c source.

2. A-C OPERATION

Be sure line voltage is 105 to 125 volts and frequency is 50 to 60 cycles before inserting power cord plug into power outlet. Be sure all tubes are securely inserted in their proper sockets before receiver power is turned on. The chart below lists the current and voltage data.

Power Consumption	90 Watts
Frequency	50/60 Cycles
Line Voltage	117 Volts
Line Current	0.77 Amperes

During a-c operation, the shorting plug supplied with the receiver must be in the octal socket on the rear apron of the chassis.

3. D-C OPERATION

The receiver may be operated from a 6 volt d-c source, generally a storage battery, and a 270 volt d-c supply in the form of "B" batteries or vibrator type power pack. Consult the

chart on power requirements at the end of this paragraph and provide battery or power pack facilities capable of supplying these demands. The receiver is connected to the d-c supply as follows:

1. Remove the octal shorting plug for a-c operation from the socket SO-1 located on the rear apron of the receiver chassis.

2. Wire an octal plug, as shown in Fig. 9, and plug it into socket SO-1. Use #19 (AWG) wire leads for the 270 volt "B" supply connections to pins #3 and #5, and #12 (AWG) wire leads for the 6 volt battery connections to pins #1, #7, and #8. **CAUTION:** Check the wiring carefully before connecting to the battery supply. The chart below lists the current voltage data.

"B" Voltage	270 Volts
"B" Current	105 ma.
Filament Voltage	6 Volts
Filament Current	3.8 Amperes

Total battery drain when operating from a 6-volt vibrator power supply is approximately 11 amperes.

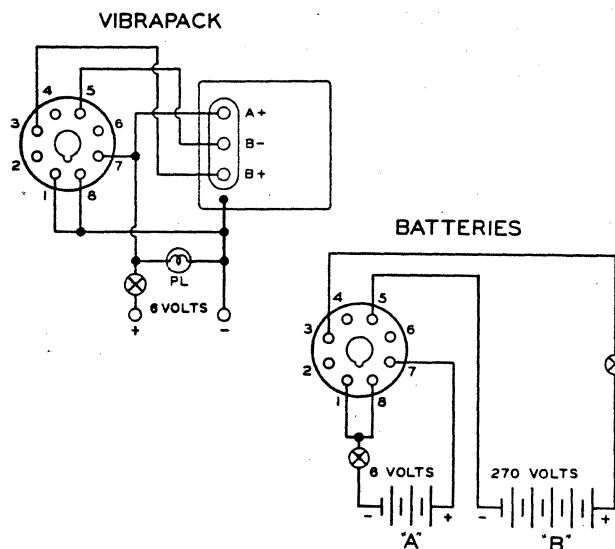

Figure 9. Octal plug wiring diagram

4. OUTPUT CONNECTIONS

Output connections for the speaker are provided for on the rear apron of the chassis. Two output impedances are available. Either the

500 or the 5,000 ohm speaker connection may be used according to the output impedance desired. This arrangement of dual output impedances will accommodate most requirements. The Hallcrafters Model PM-23 speaker requires 5000 ohms impedance; the Hallicrafters Model R-42 and R-44, requires 500/600 ohms. However, any standard type, permanent magnet dynamic speaker with proper output transformer may be connected to the output terminals. If the permanent magnet dynamic speaker impedance is unknown, try the 5000 ohm and then the 500/600 ohm impedance, and use the one which gives the better tone quality and volume.

5. PHONO INPUT CONNECTION

A receptacle is provided on the rear apron of the chassis for connecting a phonograph record player to the receiver. This receptacle is designed to accommodate a Cinch, type M-93, pin connector plug. (See Fig. 10 for diagram)

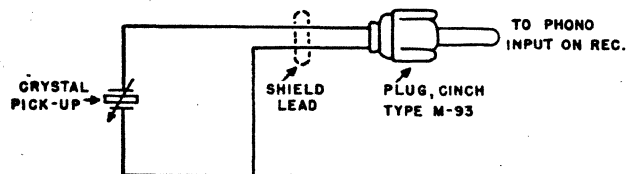

Figure 10. Phono input diagram

6. ANTENNA AND GROUND CONNECTIONS

The Model SX-43 is designed for a 300 ohm antenna impedance. The antenna impedance is not critical and excellent reception can be obtained from an antenna of from 50 to 600 ohm impedance. For maximum performance, the best possible antenna should be employed.

The antenna terminals on the Model SX-43 are arranged for any type of antenna from those requiring a ground to those using a transmission line. The transmission type of antenna connects to the A-1 and A-2 terminals whereas a single wire antenna utilizes terminal A-1 for the antenna lead. A-2 and GND terminals must be connected together and connected to a good ground.

7. DETAILED OPERATIONS

a. Controls and Their Functions. In order to obtain the desired results from the receiver, it is recommended that you become familiar with the function of each control. Red indicators on the controls for broadcast reception and green for f-m reception are there to simplify operation. Controls and their functions are as follows:

(1) BAND SELECTOR. The BAND SELECTOR knob operates the bandswitch to select the desired band frequencies.

(a) General Coverage Dial. The general coverage dial has four calibrated scales and a logging scale. Three scales are calibrated in megacycles and the broadcast scale is calibrated in kilocycles. The outer logging scale is divided into 100 divisions for logging use. The dial settings for the various amateur bands are indicated on the main tuning dial by red lines and the abbreviations 80 M, 40 M, etc. directly above the lines. When tuning the amateur bands with the calibrated bandspread dial, the general coverage dial must be set at the setting corresponding to the amateur band desired. Since the general coverage and bandspread tuning systems are electrically related on the first four bands, it is necessary to set the bandspread dial to the high frequency end or minimum capacity when tuning the receiver with the general coverage dial control to obtain correct receiver frequency readings on the general coverage dial.

(b) Bandspread Dial. The bandspread dial has five scales calibrated for the amateur bands and one scale calibrated for the high frequency FM band. The first three scales are calibrated to read receiver frequencies in kilocycles when the general coverage dial has been set to the corresponding indexing line. The FM and the 6 meter amateur band tuning is done with the bandspread dial as the general coverage dial and condenser is switched out of the circuit on bands 5 and 6. On band 5 the receiver employs dual conversion, substantially reducing image interference and permitting normal bandwidth for 6 meter AM amateur reception.

(2) NOISE-LIMITER-ON Switch. This switch opens or closes the noise limiter circuit and is to be set at ON when the operator wishes to limit excessive noise resulting from automobile ignition and other forms of noise interference.

The noise limiter circuit "clips" the intermittent noise peaks down to the level of the desired signal where they tend to become unnoticeable.

(3) RECEIVER-STANDBY Switch. When set at STANDBY, this switch renders the receiver

inoperative, while transmitting or for any other purpose, although the tube heaters remain hot and ready for instant use.

(4) CRYSTAL PHASING Control. This control permits the discrimination of code signals whose frequencies are very nearly the same. The SELECTIVITY control must be set at one of its two crystal selectivity positions when using the phasing control.

It is extremely simple to attain single signal c-w reception with the SX-43. First, set the RECEPTION switch at CW and the SELECTIVITY control at CRYSTAL SHARP. Pick a good solid c-w signal, preferably a commercial station because a commercial is likely to stay on long enough for you to complete the phasing adjustment for single signal reception.

You will find on tuning across this signal that it has two amplitudes. Tune first to the weaker of these two amplitudes. Now, turn the CRYSTAL PHASING control until the weaker of the two amplitudes is reduced to a minimum. Then, tune to the stronger of the two amplitudes and adjust the PITCH control to a tone most pleasing to you. This adjustment for single signal selectivity will hold with no further adjustment unless you change the phasing control. (See Fig. 11 for an illustration of single signal operation.)

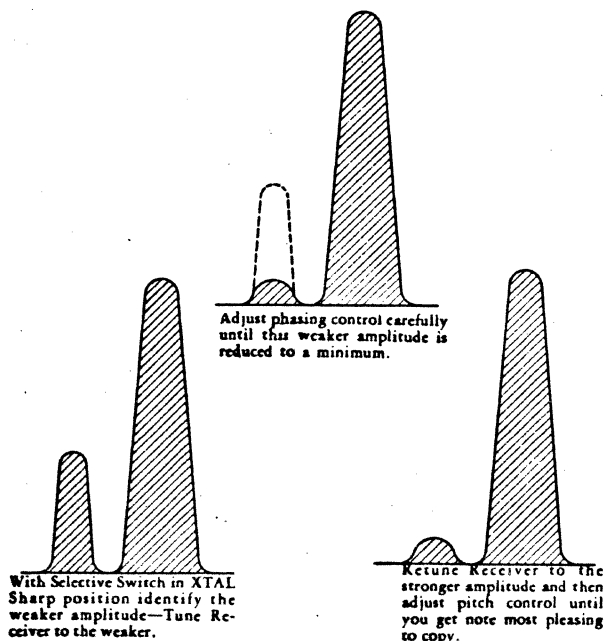

Figure 11.

Illustration showing Single Signal Operation

(5) SELECTIVITY Control. This control determines the sharpness of the response. Four degrees of selectivity are provided, ranging from CRYSTAL SHARP for c-w code reception under difficult receiving conditions to NORMAL BROAD response for BC reception.

1. NORMAL BROAD (for high fidelity reception).
2. NORMAL SHARP (for reduced adjacent channel interferences).
3. CRYSTAL BROAD (similar to sharp i-f response but with sharper cutting on sidebands).
4. CRYSTAL SHARP (position of extreme selectivity - practically no sideband content).

(6) TONE Control. This control selects the tone qualities desired by the operator. The types of response available are LOW, and HIGH.

(a) LOW. The high audio frequencies are attenuated to provide a minimum response for voice reception when the background noise level is objectionably high.

(b) HIGH. The bass and high frequencies are passed at the same level thereby providing as near a true reproduction of the original transmitted signal as possible. The response is essentially flat between 70 and 8,000 cycles per second for good fidelity reception.

(7) CW PITCH Control. This control varies the frequency of the beat frequency oscillator thus varying the pitch of the c-w code signal as desired.

(8) SENSITIVITY Control. This control adjusts the sensitivity by varying the resistance in the cathodes of the r-f and i-f amplifiers. Turning the control to the right increases the sensitivity. This control must be set at maximum sensitivity when using the carrier level meter. At any other setting of this control, readings of the carrier meter are meaningless.

8. "S" METER ADJUSTMENT

Adjustment of the "S" meter control is performed by varying the knurled knob located on the rear apron of the receiver chassis. This control enables you to properly set the "S"

meter to zero. In order to make the adjustment correctly, advance the SENSITIVITY control to 10. Set the "reception" switch to AVC position. Short the two antenna terminals to the ground terminal and tune receiver off station. Then

adjust the "S" meter control until pointer rests at "0". Remove the short from the antenna terminals and the meter will indicate the relative carrier strength of each incoming signal as it is tuned in.

SERVICE

1. REPLACING TUBES

All tubes are accessible at the top of the chassis through the hinged cover of the cabinet. When replacing tubes, check tube type carefully and replace with the correct type. Refer to top view of the chassis to determine the location of the tubes (See Fig. 12).

2. REPLACING DIAL LAMPS

The receiver employs three dial lamps with the bayonet type sockets to illuminate the main and bandspread tuning dials as well as the meter scale. The lamps are to be replaced with

with 6-8 volt, 250 ma, (blue bead) #44 G.E. type, or equivalent. Replace the tuning meter lamps with a 6-8 volt, 150 ma. (brown bead) #47 G.E. type or equivalent.

3. SERVICE OR OPERATING QUESTIONS

Factory type service is available at Hallcrafters authorized field service centers. For Warranty Service or further details regarding operation or servicing of the receiver in general, contact the dealer directly. Make no service shipments directly to the factory before first writing for authorization and instructions. *The factory cannot accept responsibility for unauthorized shipments.*

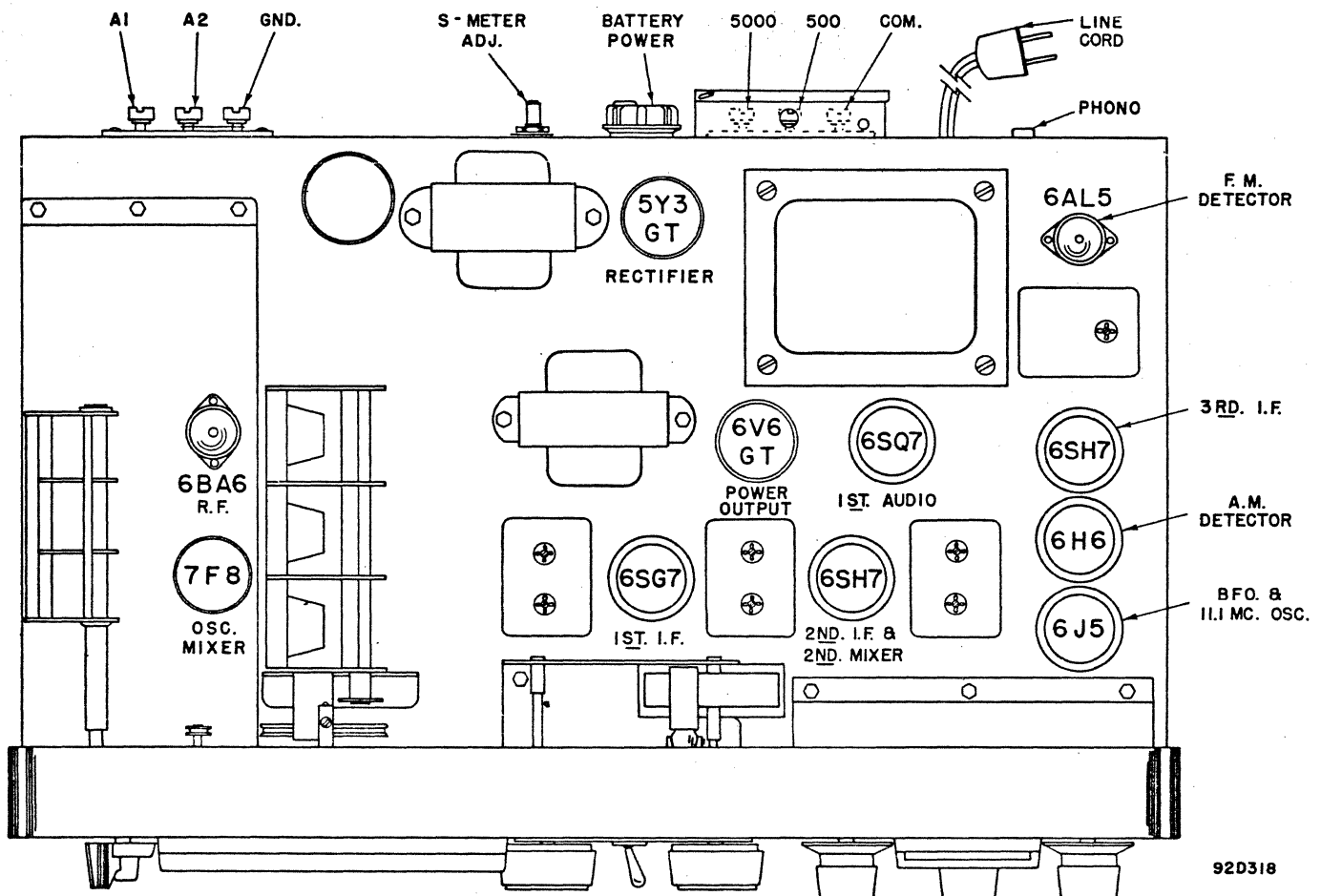

Figure 12. Top view of Chassis

REMOTE CONTROL OPERATION

Connect a single pole single throw relay to pins #5 and 8 on PL1 located on the rear apron

of the receiver. Receiver "SEND- RECEIVE" switch is then placed in "SEND" position. When the Transmitter is turned on the Receiver is automatically disabled.

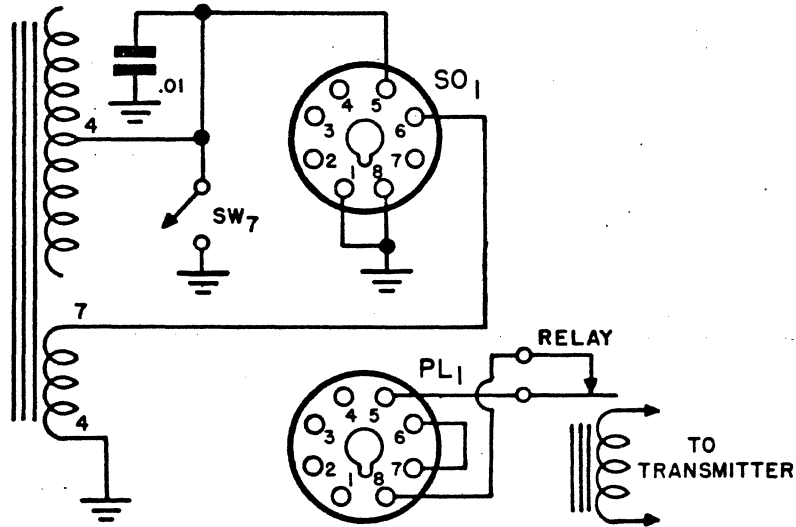
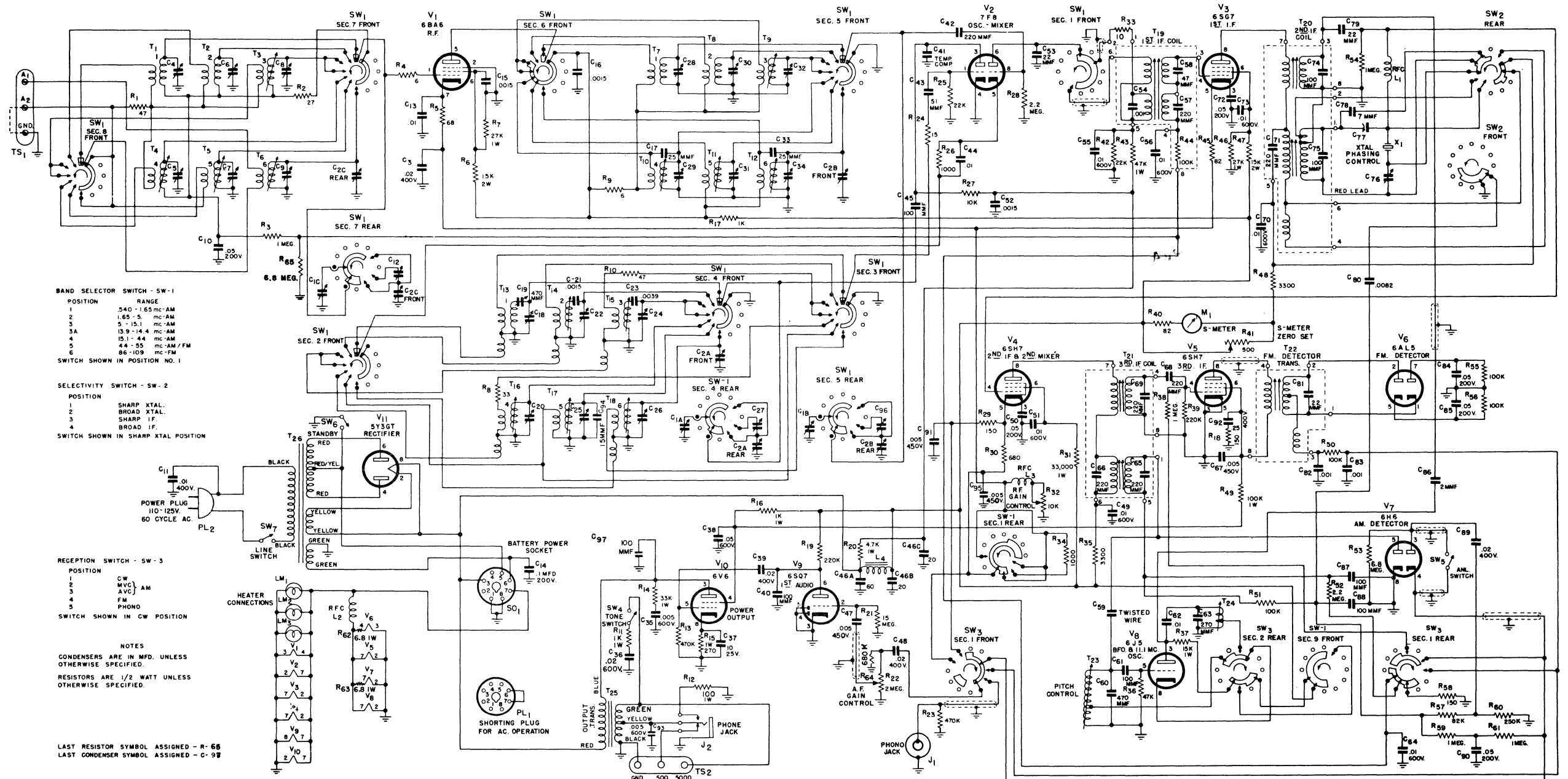

Figure 13. Schematic Remote Control Operation



BAND SELECTOR SWITCH - SW-1

POSITION	RANGE
1	540 - 1.65 mc-AM
2	1.65 - 5 mc-AM
3	5 - 15.1 mc-AM
3A	13.9 - 14.4 mc-AM
4	15.1 - 44 mc-AM
5	44 - 55 mc-AM/FM
6	86 - 109 mc-FM

SWITCH SHOWN IN POSITION NO. 1

SELECTIVITY SWITCH - SW-2

POSITION	SETTING
1	SHARP XTAL.
2	BROAD XTAL.
3	SHARP I.F.
4	BROAD I.F.

SWITCH SHOWN IN SHARP XTAL POSITION

RECEPTION SWITCH - SW-3

POSITION	MODE
1	CW
2	MVC } AM
3	AVC }
4	FM
5	PHONO

SWITCH SHOWN IN CW POSITION

NOTES
 CONDENSERS ARE IN MFD. UNLESS OTHERWISE SPECIFIED.
 RESISTORS ARE 1/2 WATT UNLESS OTHERWISE SPECIFIED.

LAST RESISTOR SYMBOL ASSIGNED - R-68
 LAST CONDENSER SYMBOL ASSIGNED - C-97

HALLCRAFTERS SX-43

Fig. 8. Schematic diagram.

NOTES

Warranty

"This product is warranted to be free from defective material or parts, and it is agreed to furnish a new part in exchange for any part of this unit which under normal installation, use and service discloses such defect, provided the unit is delivered by the owner to the authorized radio dealer or wholesaler from whom purchased, intact, for examination with all transportation charges prepaid within ninety days from the date of sale to original purchaser and provided that such examination discloses that it is thus defective.

This warranty does not extend to any radio products which have been subjected to misuse, neglect, accident, incorrect wiring not our own, improper installation, or to use in violation of instructions furnished by us, nor extend to units which have been repaired or altered outside of our authorized facilities, nor to cases where the serial number thereof has been removed, defaced or changed, nor to accessories used therewith not of our own manufacture.

This warranty is in lieu of other warranties expressed or implied and no representative or person is authorized to assume for us any other liability in connection with the sale of our radio products."