

Manual 391, Part 8
Also available as...
Manual 368
Issue 3, March 1978

the **43** teleprinter

**INSTALLATION &
ROUTINE SERVICING
for
BASIC KSR TERMINALS**



©1977 and 1978 by Teletype Corporation
All rights reserved
Printed in U.S.A.

THE 43 TELEPRINTER
BASIC KSR
INSTALLATION AND ROUTINE SERVICING MANUAL

<u>INDEX</u>	<u>PAGE</u>
PART 1 -- INTRODUCTION	
PART 2 -- INSTALLATION	
A. VARIABLE FEATURES	2-1
B. INTERFACES	2-2
C. ASSEMBLY	2-4
1. UNPACKING	2-4
2. TELEPHONE AND LINE CONNECTION	2-4
3. ACCESSORIES	2-7
4. STATION TESTING	2-7
PART 3 -- ROUTINE SERVICING	
A. TROUBLE ISOLATION AND CORRECTION	3-1
B. PERIODIC CHECKS, LUBRICATION AND CLEANING	3-4
1. GENERAL	3-4
2. VISUAL CHECKS	3-4
3. CLEANING AND APPEARANCE	3-4
4. LUBRICATION PROCEDURES	3-4
5. LUBRICATION POINTS	3-6
C. COMPONENT ACCESS	3-8
1. OPERATOR CONSOLE, CABLES, DIRECTORY CARD AND VARIABLE FEATURE SWITCH	3-8
2. POWER SUPPLY LAMP, CABLES AND FUSES.	3-8
D. ADJUSTMENTS	3-9
1. RIGHT PAPER SPROCKET	3-9
2. PLATEN ENDPLAY AND PRINTED LINE POSITION	3-9
3. LEFT-HAND MARGIN	3-10

THE 43 TELEPRINTER
BASIC KSR
INSTALLATION AND ROUTINE SERVICING MANUAL

PART 1 -- INTRODUCTION

This manual provides information on the installation and routine servicing of the 43 Teleprinter Basic KSR Terminals. Instructions are provided for service personnel, with a minimum of training, tools and spare parts, to enable variable features, connect the proper interface, correct minor troubles and periodically inspect, lubricate and clean the terminal during extended service intervals.

These 43 Teleprinter Basic KSR Terminals provide character at a time keyboard-printer send-receive operation using 12-inch wide sprocket feed paper or 8-1/2-inch wide friction feed paper. Transmission speeds are attendant controlled at 100 or 300 characters per second on terminals equipped with either an internal modem or with one of two types of digital communications interfaces.†

Terminals with an internal modem for data transmission, interface electrically with the telephone switched network and with a modular jack telephone for originating calls and talking. Terminals with digital interfaces are furnished to operate on EIA voltage levels, or on TTL voltage levels, and exchange data and control signals with external modems or other devices for communication over switched or private lines.

Information on how to check proper operation, change the ribbon cartridge and install paper is included in the How To Operate Manual 367 furnished with each terminal.

Note: When ordering replaceable components, prefix each part number with the letters "TP" (ie, TP129534), unless specified otherwise.

Tools and spare parts that may be required are as follows:

<u>DESCRIPTION</u>	<u>TELETYPE CORP. PART NO.</u>
3/16" and 1/4" Open-End Wrench	129534
1/4", 6" Blade, Screwdriver	100982
1/16" Allen Wrench	124682
1.0 A SLO-BLO Fuse	143306
1.0 A Fuse	120139
Lubricants	See Page 3-5

In the event that troubles occur that cannot be corrected with the information in this manual, refer to the applicable 43 Teleprinter Manuals: Repair Manual 391, Service Manual 369, and Circuit Diagrams Manual 385 (can be purchased from Teletype Corporation), replace the terminal, or contact the nearest Teletype Product Service Center.

†Digital Interfaces: (Teletype Corporation Technical Reference for 43 Teleprinter Basic KSR Terminals).

EIA -- Electronics Industries Association (Spec RS-232C) +25 V dc to -25 V dc
(On-Off Range)

TTL -- Transistor Logic 0 V dc to +5 V dc (On-Off Range)

PART 1 -- INTRODUCTION (Cont)

The three types of interfaces and the six basic KSR sets can be identified as shown below:

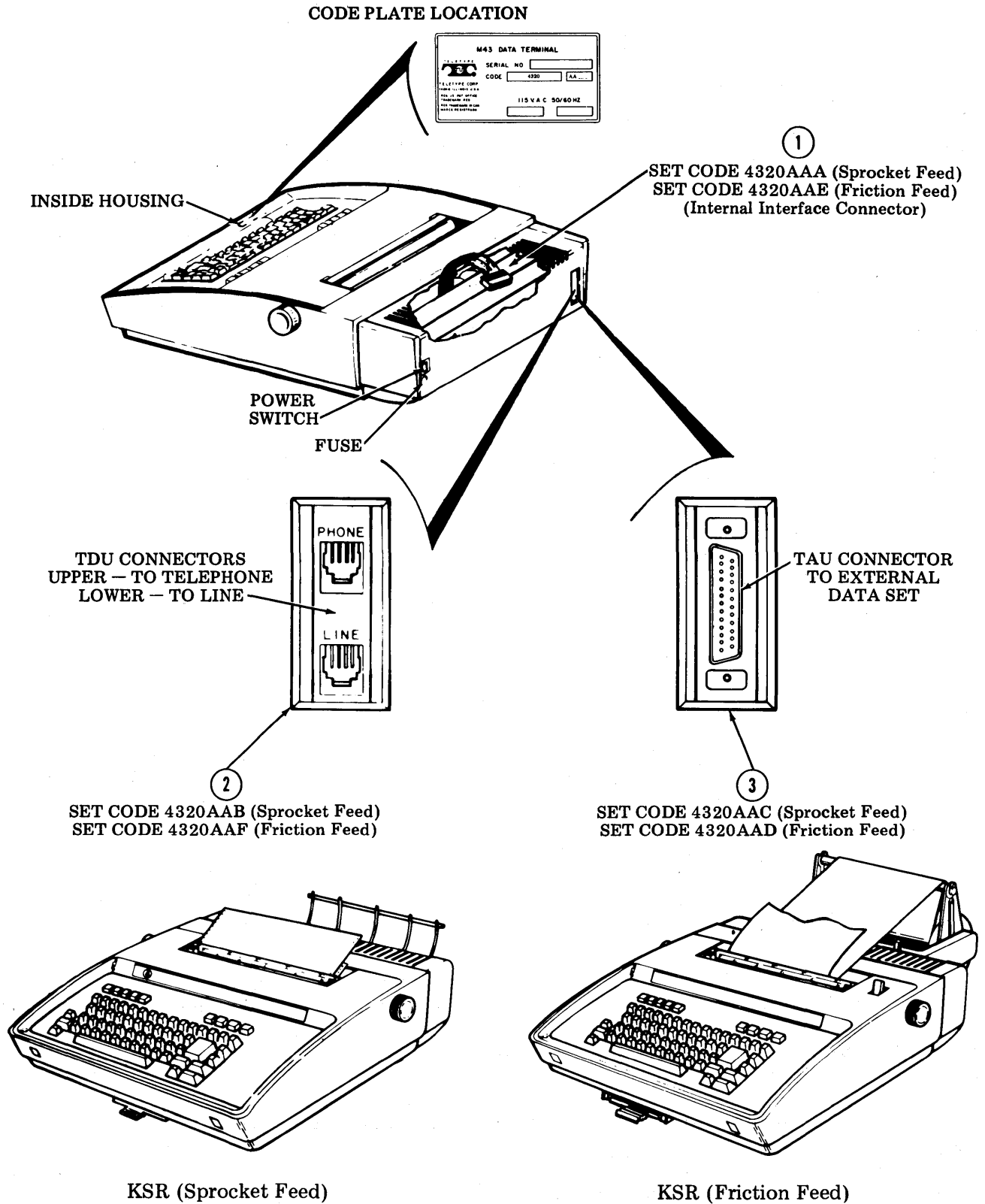

PART 2 -- INSTALLATION
A. VARIABLE FEATURES

The chart below provides information on how to set the feature shown under feature numbers 431 through 435. Record any nonstandard options enabled in the space provided on the directory card (bottom side).

Feature No.	Feature Suffix and Conditions	Feature Definition	Switch Numbers								Location of Switch on Circuit Card (See Page 3-8)
			1	2	3	4	5	6	7	8	
XXX			SPD4								
a.			-	-	-	-	○	●	-	-	*
b.			-	-	-	-	○	●	-	-	
431. Type Font Arrangement			SPD4								
			1	2	3	4	5	6	7	8	
a.		Narrow numeric 0 and wide alpha O. Standard ^ and underline _ .	-	-	-	-	-	-	●	●	*
b.		Slash numeric Ø and wide alpha O. ^ prints as ↑ and _ prints as ← .	-	-	-	-	-	-	●	○	
c.		Slash alpha Ø and wide numeric O. ^ prints as ↑ and _ prints as ← .	-	-	-	-	-	-	○	○	
432. Line Length			SPD4								
			1	2	3	4	5	6	7	8	
a.		132 Characters (Sprocket Feed Only)	-	-	-	-	●	●	-	-	*
b.		72 Characters — Printed line not centered.	-	-	-	-	○	●	-	-	
c.		80 Characters	-	-	-	-	●	○	-	-	‡
d.		72 Characters — Printed line centered (Friction Feed Only) §	-	-	-	-	○	●	-	-	
433. EOT Response			SPD4								
			1	2	3	4	5	6	7	8	
a.		Disconnect or turn off Term Ready on received EOT.	-	-	-	○	-	-	-	-	*
b.		Does not disconnect or turn off Term Ready on received EOT.	-	-	-	●	-	-	-	-	
434. Character Parity Bit Sent			SPD4								
			1	2	3	4	5	6	7	8	
a.		Even Parity	-	-	○	-	-	-	-	-	*
b.		8th Bit Mark	-	-	●	-	-	-	-	-	
435. End-of-Line on Receive			SPD4								
			1	2	3	4	5	6	7	8	
a.		Auto CR-LF performed	○	-	-	-	-	-	-	-	*
b.		Bell & Print Inhibit at last char. position	●	-	-	-	-	-	-	-	

- Indicates toggle or slide position to ON.
- Indicates toggle or slide position to OFF.
- Position of switch does not affect feature.
- * Factory furnished state of feature.

- ‡ On friction feed terminals, 432c (80 Characters) is factory furnished.
- § 432a (132 Characters) should not be selected.
- § LEFT-HAND MARGIN adjustment must be performed (See Page 3-10).

PART 2 -- INSTALLATION (Cont)B. INTERFACES (Cont)

The 4320AAB and AAF sets equipped with 430750 Terminal Data Unit (TDU) provide two modular telephone jacks for connection to the telephone equipment using modular cords. These jacks are labeled line (bottom) and phone (top) and the pin assignments are as shown:

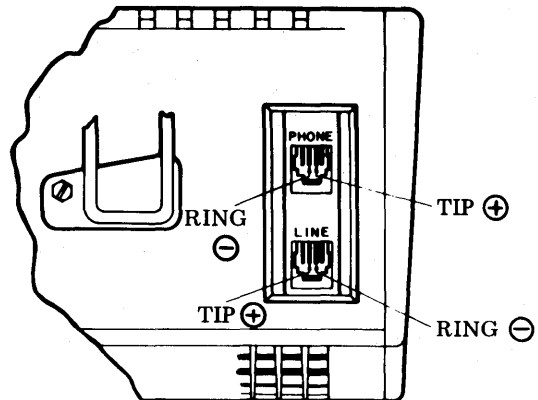

The 4320AAC and AAD sets equipped with a 430751 Terminal Auxiliary Unit (TAU) provide a 25-pin male connector for connection to an external communications device (modem) or distant terminal. The interface meets the requirements of EIA - RS-232C. (See Page 2-6 for cables available from Teletype Corporation.) The pin assignments are given below:

EIA DATA SET INTERFACE SIGNALS

<u>Connector</u>	<u>Signal</u>	<u>EIA Circuit</u>	<u>Status</u>
<u>Pin</u>		<u>Designation</u>	
1	Protective Ground	AA	Not Wired in TAU or Recommended Cable
2	Transmit Data	BA	Active
3	Receive Data	BB	Active
4	Request to Send	RS	Always Off (Issue 1B Logic Card) -- Always On (Issue 2A Logic Card)
5	Clear to Send	CB	Active
6	Data Set Ready	CC	Active
7	Signal Ground	AB	Active
8	Received Line Signal Detector	CF	Active
9			Not Wired in TAU or Recommended Cable
10			Not Wired in TAU or Recommended Cable
11	TWX Control	-	Not Applicable
12	Data Speed Indicator	SCF	Not Applicable
13			Not Wired in TAU or Recommended Cable
14			Not Wired in TAU or Recommended Cable
15			Not Wired in TAU
16			Not Wired in TAU or Recommended Cable
17			Not Wired in TAU
18	TWX Indicator	-	Not Applicable, Not Wired in Recommended Cable
19			Not Wired in TAU or Recommended Cable
20	Data Terminal Ready	CD	Active
21			Not Wired in TAU or Recommended Cable
22			Not Wired in TAU or Recommended Cable
23	Data Speed Select	CH	Always Off
24			Not Wired in TAU or Recommended Cable
25	Analog Loop Test		Active

The 4320AAA and AAE sets are furnished without the interface signaling unit. Connection to the external communications device (provided by the customer) is made through a 20-pin connector, Berg 65346-003 or 3M 3421-300 or equivalent at the end of a short ribbon cable. No provision is made for adding additional cable length.

Electrical Characteristics of Interface Leads are:

Electrical signals compatible with low-power TTL logic are utilized for both control and data interchange as described below:

STATE	DRIVER	TERMINATOR
MARK (OFF) (1)	$+2.4 \leq V_{\text{MARK}} \leq +5.25$ Volts	$+2.0 \leq V_{\text{MARK}} \leq +5.25$ Volts
SPACE (ON) (0)	$0 \leq V_{\text{SPACE}} \leq +0.4$ Volts	$0 \leq V_{\text{SPACE}} \leq +0.7$ Volts

TTL PIN ASSIGNMENT CHART

<u>Pin No.</u>	<u>Code</u>	<u>Function</u>	<u>Status</u>
1	DL	Digital Loop Test	Active
2	DSI	Data Speed Indicator to Terminal	Not Applicable, Not Wired in TTL Cable
3	AL	Analog Loop Test	Active
4	DSS	Data Speed Select from Terminal	Not Applicable, Not Wired in TTL Cable
5	TR	Terminal Ready	Active
6	RS	Request to Send	Not Connected, Always Off (Issue 1B Logic Card) -- Always On (Issue 2A Logic Card)
7	+5	+5 Volts	Active
8		Reserved for future	Not Applicable, Not Wired in TTL Cable
9	GND	Circuit Ground	Active
10		Reserved for future	Not Applicable, Not Wired in TTL Cable
11	-12	-12 Volts	Active
12		Reserved for future	Not Applicable, Not Wired in TTL Cable
13	+12	+12 Volts	Active
14	DP	Duplex Indicator from Terminal	Not Applicable, Is Wired in TTL Cable
15	DR	Data Ready	Active
16	TW2	TWX Indicator	Not Applicable, Not Wired in TTL Cable
17	RD	Receive Data	Active
18	TW1	TWX Control	Not Applicable, Not Wired in TTL Cable
19	SD	Transmit Data	Active
20		Reserved for future	Not Applicable, Not Wired in TTL Cable

PART 2 -- INSTALLATION (Cont)
C. ASSEMBLY

The basic 43 Teleprinter set is furnished fully assembled and tested with one of the signal interfaces described on Page 2-2, B. INTERFACES.

CAUTION: To avoid condensation on the electrical components, the terminal should be allowed to assume room temperature before unpacking, for example, when brought into a warm humid room from outside subzero temperatures.

1. UNPACKING

- a. Unpack the large carton referring to instructions on the container.
- b. Remove tape securing the cover to the housing (see below).
- c. Depress the cover locking tabs on the lower front of the cabinet and lift the cover. Remove the packing detail securing the print head (see below).
- d. Verify that the following items are included in the box:

- 1 - Set -- 43 Teleprinter (4320AAA, AAB, AAC, AAD, AAE or AAF)
- 1 - Ribbon
- 1 - Manual, Installation and Routine Servicing, 368
- 1 - Manual, Attendant, 367
- 1 - Paper Holder (Sprocket Feed Only)
- 1 - Paper Supply Assembly (Friction Feed Only)

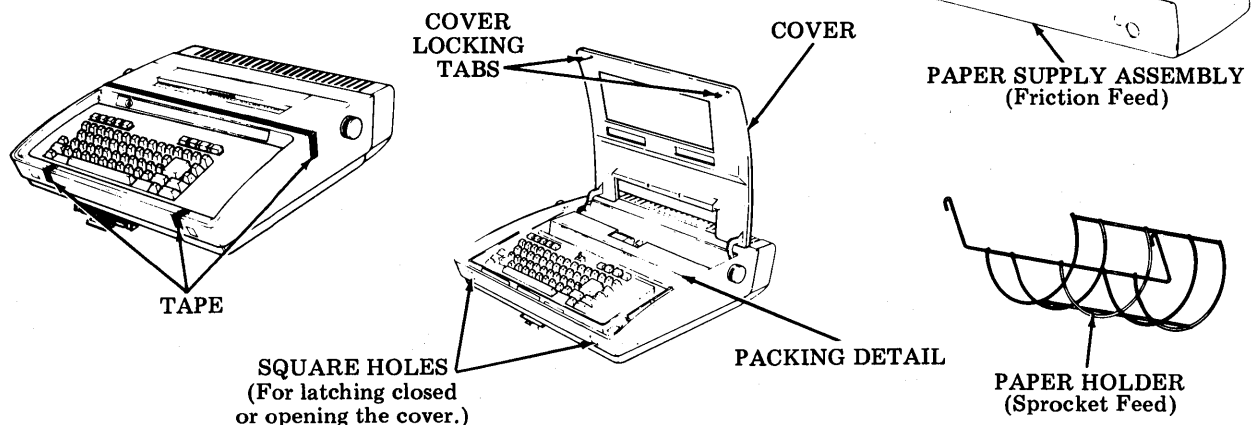

NOTE: Fan-fold 12 by 8-1/2 inch paper (sprocket feed), 8-1/2 inch wide by 5 inch diameter rolls (friction feed) and EIA and modular telephone cords must be obtained locally or ordered separately. Refer to HTO for paper suppliers. EIA and modular telephone cords can be ordered from Teletype Corporation (see Page 2-6).

2. TELEPHONE AND LINE CONNECTION

NOTICE: In the U.S.A., under the FCC registration program, the 43 Teleprinters with 430750 terminal data units (TDU) may be connected directly to the telephone switched network subject to the following conditions:

- a. Connection must be through a standard six-pin miniature jack (USOC RJ11C) installed by the Telephone Company.
- b. The telephone, if any is to be connected to the teleprinter, must be registered or grandfathered (Bell System 500 or 2500 type or equivalent) and be reported as such to the local Telephone Company.

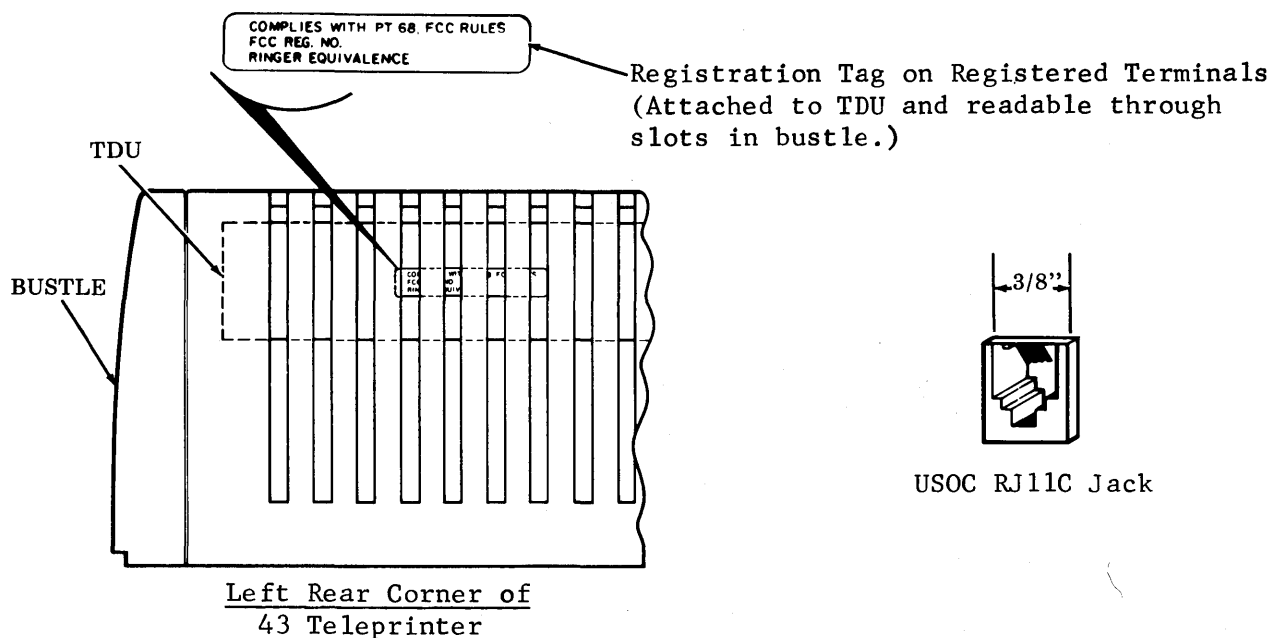

- c. Before connection or reconnection to the switched network, the local Telephone Company must be advised of the following:

Registered Terminals Only
(With Registration Tag)

- (1) Registration Number (from tag)
- (2) Ringer Equivalence (from tag)
- (3) Telephone number where terminal will be connected.

Grandfathered Terminals Only
(No Registration Tag)*

- (1) Teleprinter model number 4310 (RO) or 4320 (KSR) with suffix AAB (sprocket feed) or AAF (friction feed). Includes built-in Western Electric 153A1 modem (TDU).
- (2) Telephone number where terminal will be connected.
- (3) Ringer Equivalence: 0.3
- (4) Ringer Type: A
- (5) Voice baud metallic signal power: Nonadjustable -9 dbm max.
- (6) Baud Rate: 300 max.

*First time connection must take place before July 1, 1979. The teleprinter may remain connected and be reconnected for its life.

- Refer to Manual 407 for additional registration instructions.

4320AAB and AAF Sets With TDU

- a. Remove the modular cord plug from the modular jack associated with the keyless telephone to be used with the teleprinter (squeeze tab to release). Connect the plug to the lower connector marked LINE on the rear of the TDU accessible through the opening in the left rear of the bustle cover (Page 2-6).
- b. Connect the additional modular cord between the upper connector on the TDU marked PHONE and the telephone jack (Page 2-6).

- c. The modular telephone cord connected between the upper connector on the TDU and the telephone jack must be furnished by the installer. The following cables are available from Teletype Corporation.

7 foot length	430581
14 foot length	430582
25 foot length	430583

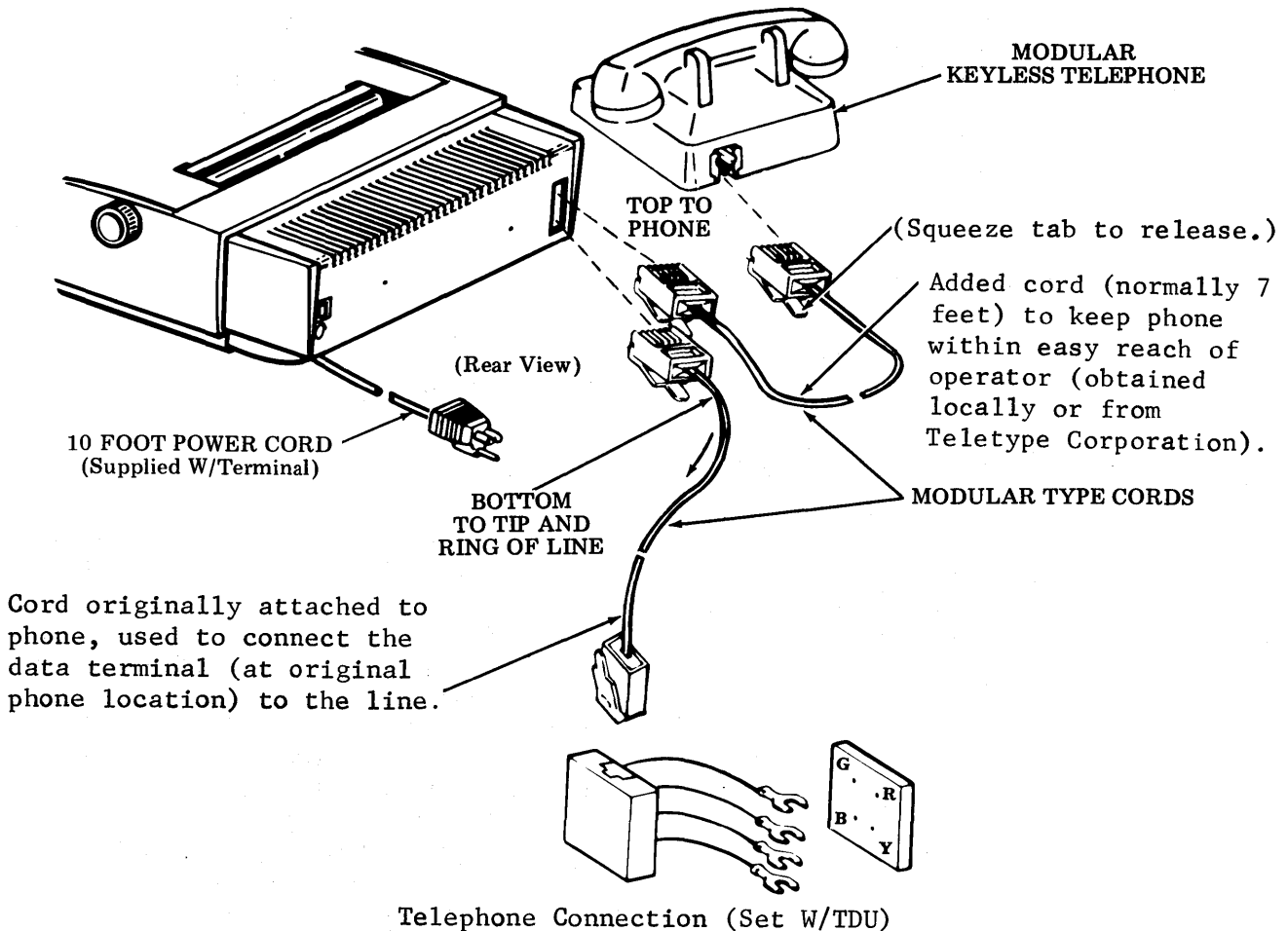

4320AAC Set With TAU

- a. The connecting cables between the terminal and the data set must be furnished by the installer and should employ shielded cable. The following cables are available from Teletype Corporation.

7 foot length	408065
12 foot length	408066
25 foot length	408067
50 foot length	408068

- b. The connection to the data set and telephone should be made following the instructions for the particular data set involved (Page 2-7).

PART 2 -- INSTALLATION (Cont)
C. ASSEMBLY (Cont)

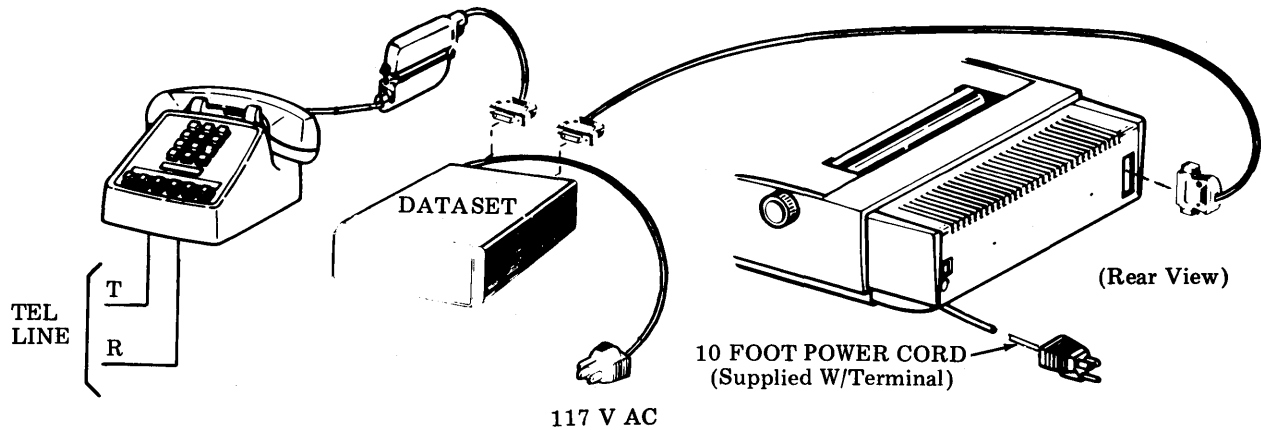

Telephone Connection (Set W/TAU)

4320AAA and AAE Sets Without Interface Signaling Unit

Connection to the 43 Teleprinter interface cable requires the removal of the paper holder or paper supply assembly, paper deflector (if present) and bustle cover. Refer to Page 3-8, C. COMPONENT ACCESS for removal instructions.

This set is not equipped with a communications unit and telephone and line connections cannot be made until the KSR set is provided with an appropriate communications device. The connections to the telephone, data set or communications device should be done following the instructions for the particular device involved.

3. ACCESSORIES

- a. Install the ribbon and paper. Refer to Manual 367.
- b. Install the friction feed paper supply assembly or the sprocket feed paper holder, if desired. If the paper holder is not installed, provide to attendant for possible future use. Refer to Page 3-8.
- c. Record any nonstandard options enabled in the space provided on the directory card. (Write in any not listed on card.)
- d. Fill out remaining information on the directory card in accordance with local procedures, (ie, provide attendant with HTO manual, ribbon ordering form, etc).
- e. Install the directory card in the holder provided, "Frequently Called Numbers" side up. Refer to Page 3-8.

4. STATION TESTING

After installation, the station shall perform as stated in the How To Operate Manual 367.

PART 3 -- ROUTINE SERVICING
A. TROUBLE ISOLATION AND CORRECTION

QUESTIONS	YES	NO
1. Are any of the three communications mode keys lit? (Power available and set power on.) (Depress other keys if proper key not lit.)	Go to 2.	Go to 1a.
1a. Is there any indication of power in the set? (Lamps flash when power is turned on and off, red lamp on power supply, etc). (See Page 3-8.)	Go to 1b.	Check and replace set fuse (F1) if blown. Trouble is in terminal if fuse blows again. If not blown go to 1b.
1b. Is red lamp on power supply lit?	Check opcon cable connector. (See Page 3-8.)	Check fuse (F2) on power supply. If blown, check for foreign objects between circuit lands or terminals and replace fuse. Trouble is in terminal if fuse blows again.
2. Does printer print test message while the PRINTER TEST key is depressed? (ie, character set printed repeatedly within margin restraints.)	Go to 2a.	Turn off power for several seconds and retry. Trouble is in terminal.
2a. Are any of the following characters substituted in copy? <div style="text-align: center;"> </div>	Check Page 2-1, <u>A. VARIABLE FEATURES</u> , 431.	Go to 2b.
2b. Are undesired line lengths set as follows when power is turned on? <div style="text-align: center;"> 72 80 132 </div>	Check Page 2-1, <u>A. VARIABLE FEATURES</u> , 432.	Go to 2c.

PART 3 -- ROUTINE SERVICING (Cont)
A. TROUBLE ISOLATION AND CORRECTION (Cont)

QUESTIONS	YES	NO
2c. Is printed copy properly centered or aligned with edges of paper? Sprocket Feed - Parallel to edge and not printing on fold or form line. Friction Feed - Properly centered on roll paper.	Go to 2d.	Sprocket Feed - Check <u>Right Paper Sprocket</u> adjustment and <u>Printed Line</u> adjustment. (See Page 3-9.) Friction Feed - Check <u>Left-Hand Margin</u> adjustment. (See Page 3-10.)
2d. Is print density acceptable (including any carbons)?	Go to 3.	Replace ribbon. Check proper density multicopy paper.
3. Are data messages properly sent and received in DATA mode?	Go to 4.	Go to 3a.
3a. Do PARITY, DUPLEX and CPS keys alternately lock down and release up when depressed?	Go to 3b.	Trouble is in terminal.
3b. Does substitute character ■ appear with PARITY key on?	Go to 3c.	Go to 4.
3c. Are both stations operating at same speed, is local copy obtained and is remote station sending even parity?	Go to 4.	Select proper speed and DUPLEX keys. Operate with PARITY switch off or check Page 2-1, <u>A. VARIABLE FEATURES</u> , 434 if remote station is printing the ■ character.
4. Does terminal have a directly connected modular telephone?	Go to 5.	On-line communications troubles encountered using externally connected data sets and telephones or other arrangements may be isolated by observing signals at the EIA or TTL interface connector. See Page 2-2, <u>B. INTERFACES</u> .
5. Does AUTO ANSW key light when power is turned on and do LOCAL-TALK, AUTO ANSW and DATA keys each light when depressed?	Go to 6.	Trouble is in terminal.

QUESTIONS	YES	NO
6. Does telephone operate normally with LOCAL-TALK key lit?	Go to 7.	Check proper connection of modular cords at rear of set. See Page 2-2, <u>B. INTERFACES</u> . Connect phone directly to line. Go to 6a.
6a. Does phone now operate normally?	Check cord that was between phone and terminal. If OK, trouble is in terminal.	Check connections to line and cord between phone and line. Replace phone.
7. When originating a call (answering tone heard) and DATA key depressed, does DATA key light steadily?	Go to 8	Go to 9.
8. Does phone ring only once and the DATA key light following a received call in the AUTO ANSW mode?	Go to 9.	Originating station must send originating frequency tones, ie, go to DATA mode. If OK, trouble is in terminal.
9. Does station echo-back characters (print twice) in ANALOG LOOPBACK -- HALF DUPLEX mode? (ie, depress AUTO ANSW key, ESC key and shifted > key.) (Alarm lamp flashes.)	Remote station may be sending incorrect frequencies or signal levels.	Trouble is in terminal.
10. Does carriage return automatically when line lengths beyond the right margin are received on-line and does station disconnect when EOT is received?	Place in service.	Check Page 2-1, <u>A. VARIABLE FEATURES</u> , 433 or 435. If OK, trouble is in station.

PART 3 -- ROUTINE SERVICING (Cont)

B. PERIODIC CHECKS, LUBRICATION AND CLEANING (Cont)

1. GENERAL

This part provides routine servicing procedures for the 43 Teleprinter Basic KSR Station.

Routine servicing should be performed, at the convenience of the customer, at least once a year.

Routine servicing consists of visual checks, lubrication, and cleaning. When performed at routine intervals, the possibility of later troubles will be reduced.

Following the routine servicing, a local and on-line installation checkout should be performed. The routine servicing date should be filled out on the bottom side of the directory card holder.

2. VISUAL CHECKS

The following areas should be checked for mechanical condition:

- a. Frayed belts on spacing and line feed motors
- b. Worn or frayed ribbon
- c. All cable connectors fully seated (Page 3-8).
- d. Print head cover fully seated.

3. CLEANING AND APPEARANCE

Examine exterior areas for smudges, dust, etc.

Check proper fit of cover. Replace extremely damaged or discolored cover, housing, bustle, etc.

Exterior cleaning should normally be limited to wiping with a soft cloth moistened with a mild detergent. However, in case of ink stained plastic surfaces, a waterless (nonabrasive) hand cleaner or a lather from abrasive bar soap applied with a cloth should be used.

Interior areas should be examined with the cover opened and accumulations of paper dust or ribbon fragments cleaned by carefully brushing loose material onto a cloth. Ink stains or deposits on interior surfaces, ribbon rollers, platen, etc, can be wiped with a cloth dampened in mineral spirits.

WARNING: DO NOT ALLOW MINERAL SPIRITS OR SOLVENTS TO CONTACT EXTERIOR PLASTIC SURFACES.

4. LUBRICATION PROCEDURES

The printer can be lubricated by opening the cabinet cover. Apply lubricant to points as indicated on Pages 3-6 and 3-7.

On small parts, a minimum amount of lubricant should be applied so that the lubricant remains on the parts and does not run off.

Excessive lubricant should be removed with a dry, lint-free cloth.

The following areas must be kept dry, free of all lubricant: All electrical components, including terminals. All parts normally touched by the operator, including exposed surfaces in ribbon, paper handling areas, and all large flat areas.

The following symbols indicate the quantity of lubricant to be used in a specified area: Symbols O1, O2, O3, etc, refer to 1, 2, 3, etc, drops of oil.

The following list of symbols applies to the lubrication instructions and the type of lubricant to be used:

- O Oil 88970 (1 qt), 88971 (1 gal), 318775 (4 oz).
- G-A Apply thin film of 97116 (4 oz) or 88973 (1 lb) grease.
- G-B Apply thin film of Syn-Tech grease (use 430836 tube with grease and 430838 brush).
- G-C Fill with Poly Oil grease (use 430837 injector with grease).
- S Saturate felt oilers, washers, and wicks with oil.
- D Keep dry, no lubricant permitted.

Lubrication Check List: (See Pages 3-6 and 3-7.)

Lead Screw -- Film of grease over entire threaded portion of lead screw.
 Carriage Wicks -- Saturate with oil (4 places)
 Ribbon Guide Rollers -- 2 drops of oil (2 places)
 Ribbon Rollers -- 2 drops of oil (2 places)
 Ribbon Tension Arm Pivot and Spring -- 2 drops of oil each (4 places)
 Spacing Tension Arm Pivot, Roller and Spring -- 2 drops of oil each (4 places)
 Platen Bearing -- 5 drops of oil each side (2 places)
 Finger Pivots -- 2 drops of oil each side (2 places)
 Paper-Out Arm Pivot -- 2 drops of oil on both pivot points (sprocket feed only).
 Lead Screw Pulley Clip -- Grease between clip and lead screw shaft.
 Pressure Roller Bail Spring -- 2 drops of oil each end (2 places - friction feed only).
 Platen Tray Shaft -- 2 drops of oil each end at the side plates (2 places - friction feed only).
 Pressure Roller Bail -- 2 drops of oil each end at pivot points on each side of bail (2 places - friction feed only).

Carriage and Nut Engaging Surfaces:

- a. Two Nut Drive Arms -- Grease four bearing surfaces.
- b. Nut Keying Arm -- Lubricate by packing carriage engaging slot with grease.

Print Head:

- a. Active Armatures and Outer Pole Plate -- Grease at the upper pivot area as well as the lower locator area (9 places).
- b. Print Wire Well Area -- Completely fill with grease.

PART 3 -- ROUTINE SERVICING (Cont)
B. PERIODIC CHECKS, LUBRICATION AND CLEANING (Cont)

5. LUBRICATION POINTS

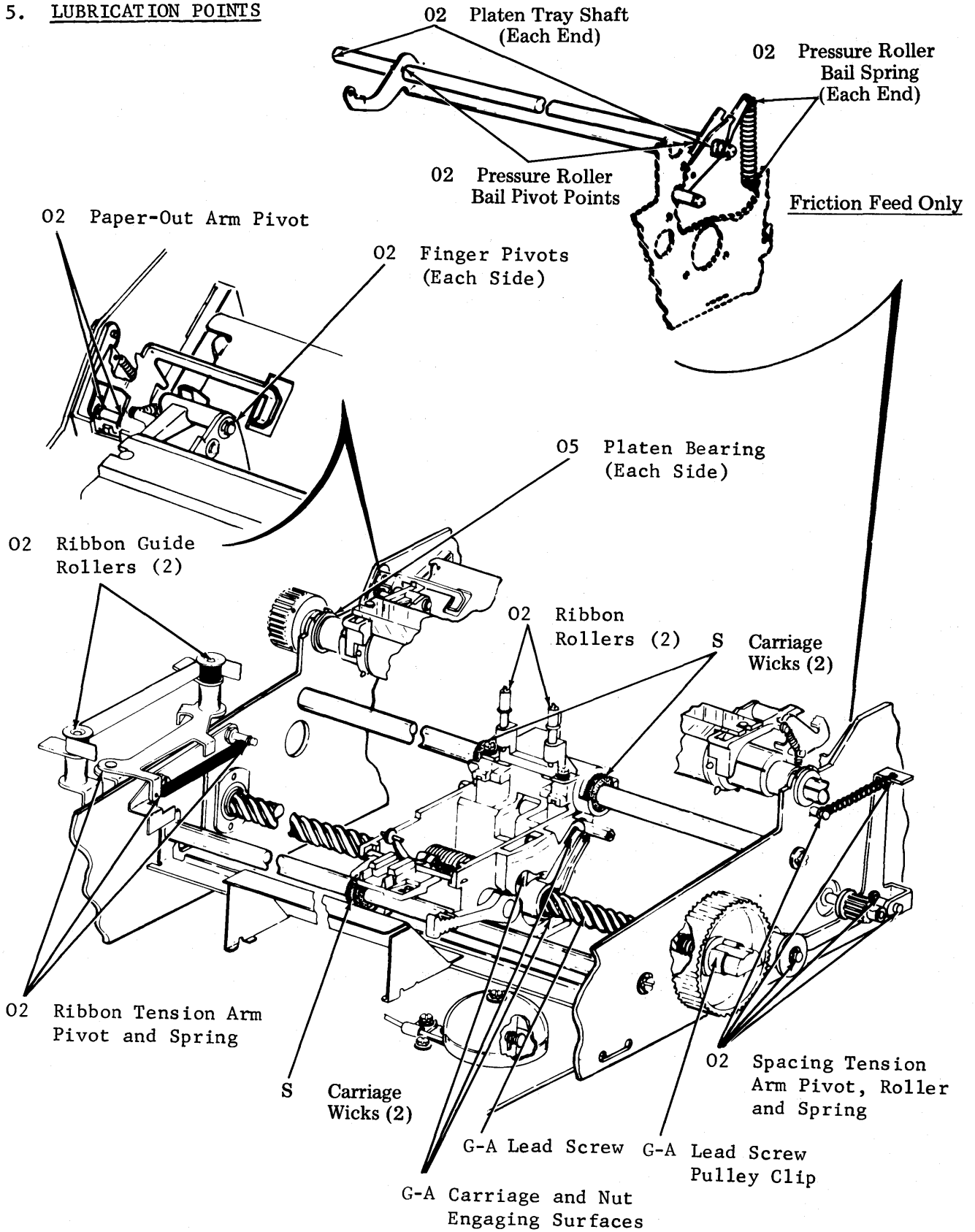

PART 3 -- ROUTINE SERVICING (Cont)
B. PERIODIC CHECKS, LUBRICATION AND CLEANING (Cont)

5. LUBRICATION POINTS (Cont)

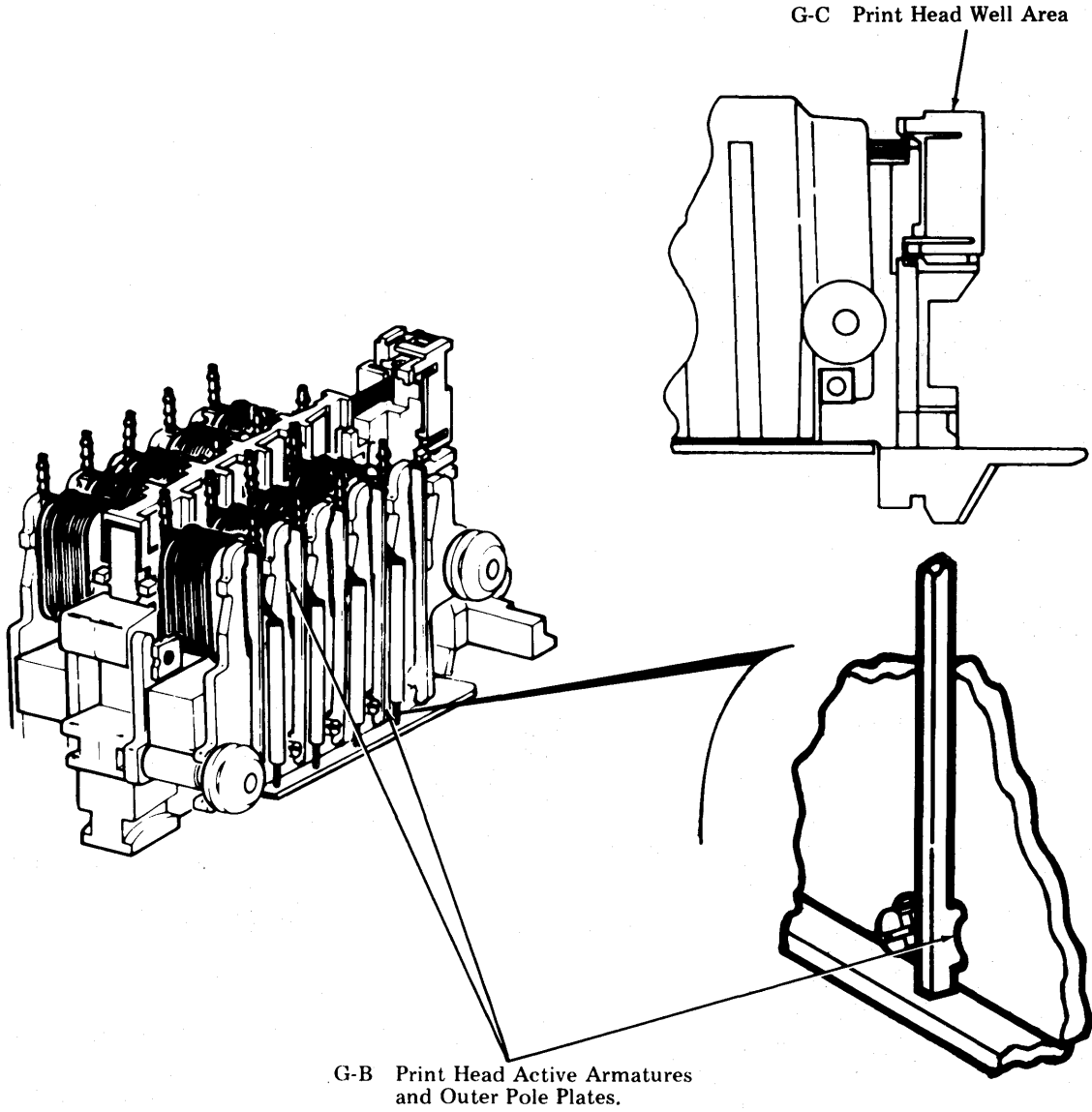

PART 3 -- ROUTINE SERVICING (Cont)

C. COMPONENT ACCESS

1. Operator Console (Opcon), Cables, Directory Card and Variable Feature Switch

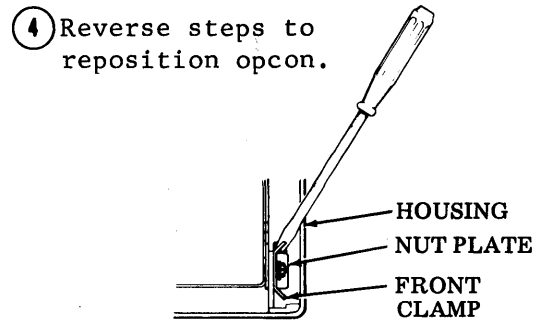
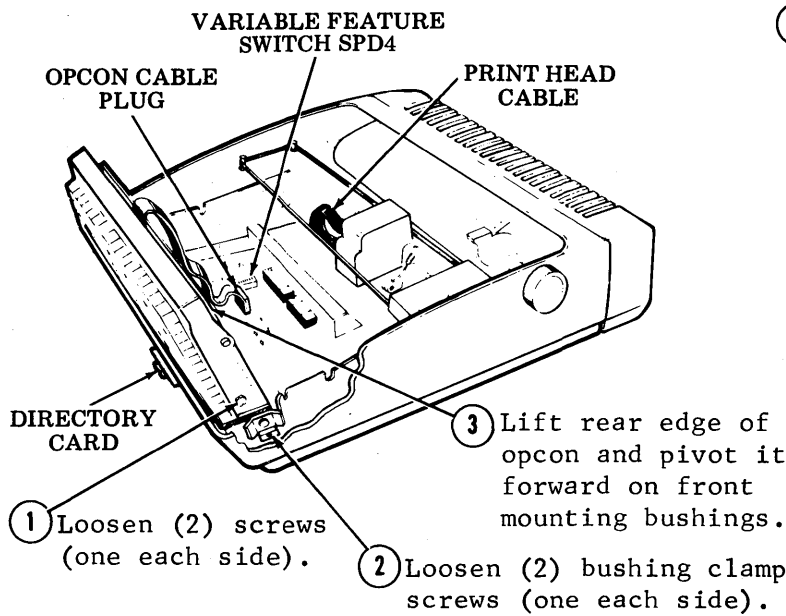

NOTE: When repositioning opcon, insert a screwdriver into the square hole in the nut plate and gently twist (or pry) the screwdriver with enough force to draw the assembly forward.

CAUTION: DO NOT OVERTWIST THE SCREWDRIVER.

Tighten the clamp screws.

2. Power Supply Lamp, Cables and Fuses

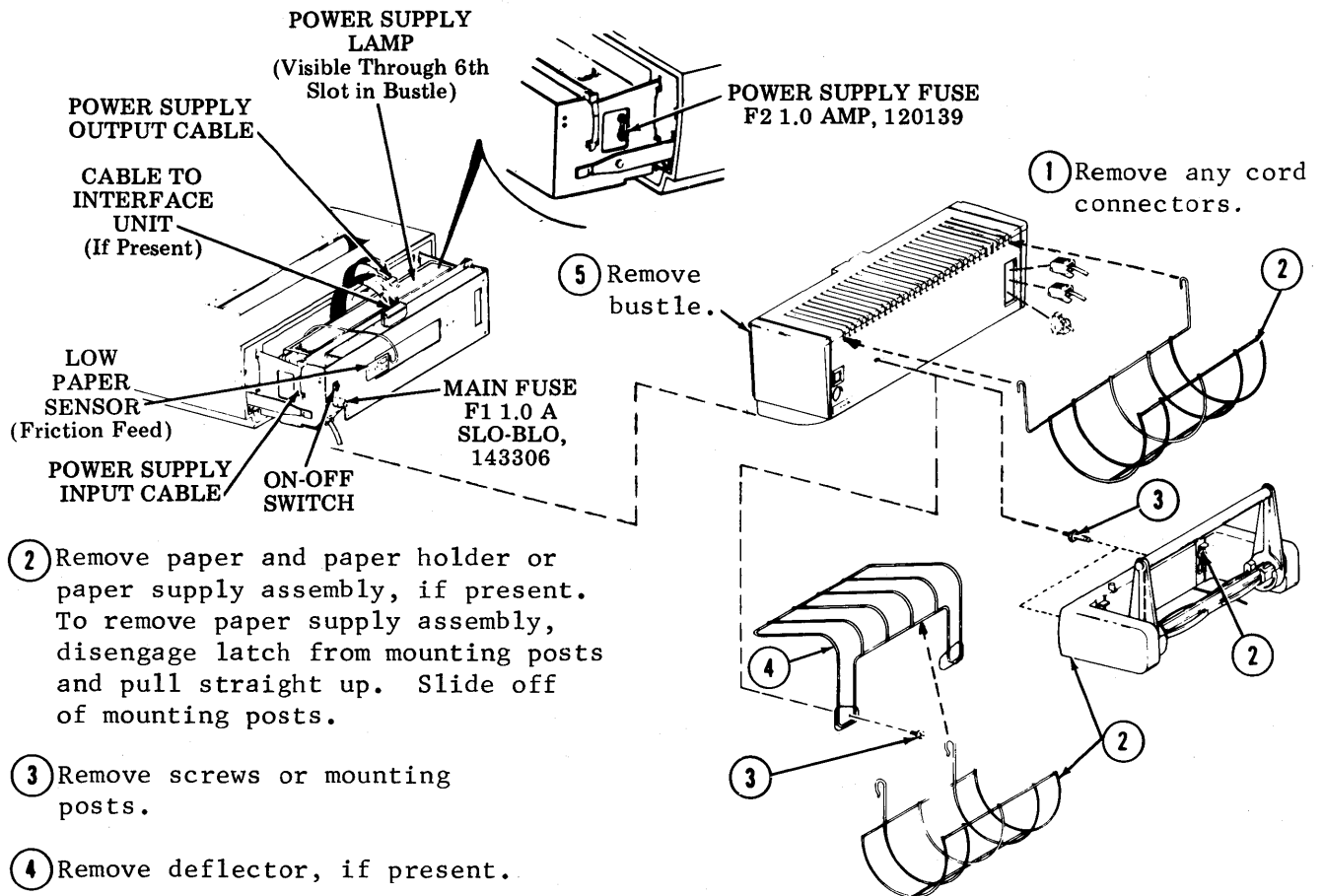

PART 3 -- ROUTINE SERVICING (Cont)
D. ADJUSTMENTS

RIGHT PAPER SPROCKET (Sprocket Feed Only)

Requirementment

The right sprocket should be biased against the collar of the platen hub and the pins should be in line with the pins of the left sprocket.

To Adjust

Loosen setscrews and position right sprocket to meet requirement.

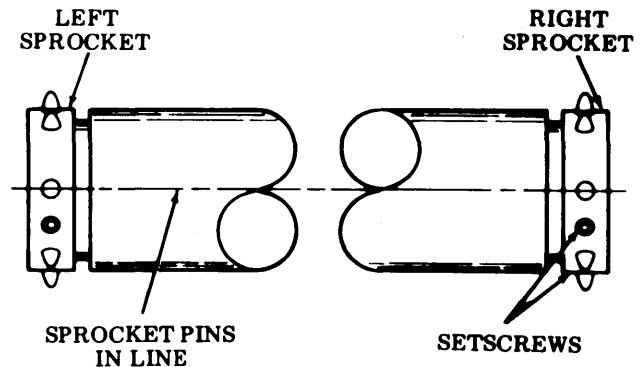

PLATEN ENDPLAY AND PRINTED LINE POSITION

The following two requirements must be met:

(1) Requirement

Platen Endplay -- With the platen biased against the right bearing, there should be

Min Some---Max 0.008 inch clearance between the left bearing and the platen hub, at the closest point, and

Min Some---Max 0.030 inch between the left bearing and the sprocket at the closest point.

(2) Requirement (Sprocket Feed Only)

Printed Line Position -- The lower edges of a typed line of M characters should be $1/32 \pm 1/64$ inch above a horizontal line located by any of the following methods:

- (a) A line drawn between the lower edges of two opposite sprocket holes.
- (b) A preprinted line on the form the same as in (a) above or in $1/6$ inch multiples.
- (c) A fold midway between two sprocket holes on fanfold paper.

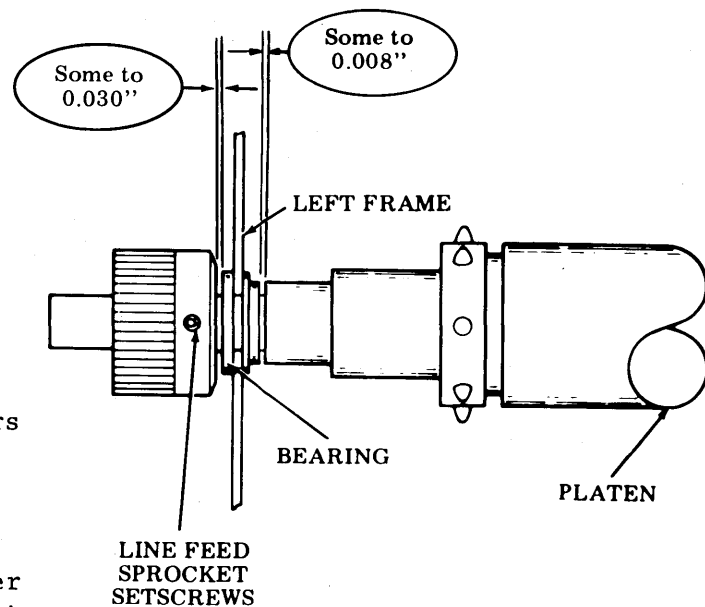

(Power must be on line feed motor for this adjustment.)

To Adjust

Loosen the line feed sprocket (at platen) setscrews and position. Print the character "M" across the line and check (2) Requirement. If necessary, loosen setscrew on right sprocket to meet alignment requirement.

LEFT-HAND MARGIN (Friction Feed Only)

Requirement

When the variable feature switch arrangement on the printer logic card has been enabled for 80 character lines, the slide should be located all the way to the left. When the switch arrangement has been enabled for 72 character lines and printed line centering (Option 432d) is required, then the slide must be located all the way to the right.

To Adjust

Loosen the single mounting screw holding the slide to the bracket and move the slide to meet the adjustment.

