



MP/MII Operating System Manual

ALTOS 580-10
and
Series 5

November 15, 1982

Part Number 690-12991-001

© 1982 Altos Computer System

(408) 946-6700 Telex: 171562 ALTOS SNJ or 470642 ALTO UI

942-0555

SERIES 5 AND 580-10 COMPUTER SYSTEM
MP/M II OPERATING SYSTEM MANUAL
REVISION D

This revision replaces but does not obsolete previous versions of this document. The information contained herein is subject to change without notice. Changes will be incorporated in new editions of the document as they are published.

Copyright 1982
Altos Computer Systems. All rights reserved.

Table of Contents

Section 1. MP/M II PROGRAM DESCRIPTION

GENERAL INFORMATION	1-1
MP/M II Program Functions	1-1
Booting From Floppy or Hard Disk Drives	1-2
DIGITAL RESEARCH MANUALS	1-2
DOCUMENTATION CONVENTIONS	1-3
SCOPE OF THIS REVISION	1-3

Section 2. INSTALLATION OF MP/M II

INTRODUCTION	2-1
SYSTEMS WITH A HARD DISK UNIT	2-2
SYSTEMS WITHOUT A HARD DISK UNIT	2-4
ERROR HANDLING	2-5
LOGICAL DISK DRIVE ASSIGNMENTS	2-5

Section 3. USING ALTOS MP/M II UTILITY PROGRAMS

MUTIL - UTILITY PROGRAM	3-1
MPMSETUP	
Introduction	3-3
MPMSETUP Functions	3-4
P - Printer Setup	3-4
N - Change Default Logical Names	3-4
U - Update the Setup File	3-4
C - Console Baud Rate Setup	3-5
Q - Quit	3-5
MPMSETUP Command Line Options	3-5
DISKSTAT	3-6
MODIFYING THE SYSTEM WITH GENSYS	3-6
Changing the Number of System Users	3-6
Virtual Disk	3-7
GENSYS for One or Two Bank Systems	3-7
MP/M II DIRECTORY	3-11

List of Figures

3-1. Sample GENSYS Run	3-9
------------------------------	-----

SECTION 1.

MP/M II PROGRAM DESCRIPTION

GENERAL INFORMATION

This manual provides the necessary instructions for the installation of the MP/M II Operating System after the Altos Diagnostic Executive (ADX) Program has been successfully completed.

MP/M II Program Functions

MP/M II is a group of control programs that coordinate the activity of your Series 5 or 580-10 computer system. The programs control memory utilization, manage files, access hardware devices, and perform other housekeeping chores. Some of these capabilities can be executed from the console and some can be used by applications programs.

A backup copy of the MP/M II master should be made before proceeding to use the system. To protect the master diskette, at least two copies should be made. One copy, the MP/M II system diskette, is for daily use. The other, the backup master, is used for making additional copies for daily use. The MP/M II master diskette is not for daily use but should be stored, together with the backup masters, in a secure location away from the computer to prevent accidental use. Refer to Section 2. INSTALLATION OF MP/M II for detailed instructions to create backup copies of the master diskette.

Booting From Floppy or Hard Disk Drives

There are two methods of bootstrapping or loading the MP/M II operating system that are available with the Series 5 or 580-10 computer system. One is booting from a floppy diskette and the other from a hard disk. When booting from a floppy diskette, regardless of the type/model of Series 5 or 580-10 computer, it is necessary to use the right-hand (RH) floppy disk drive. This is also designated as floppy drive 1.

DIGITAL RESEARCH MANUALS

For convenience, here is a brief look at the Digital Research manuals for MP/M II. They are all furnished with your system, and are the basic reference for MP/M II.

MP/M II OPERATING SYSTEM--USER'S GUIDE

This is the basic manual for all users of MP/M II, and explains how to use the MP/M II operating system and run application programs on it. It provides general information about the structure and facilities of MP/M II.

The manual gives information on system messages, commands, file handling, and MP/M II utility programs. It also contains general reference material, including command summaries, control characters, options, errors, and trouble-shooting procedures.

MP/M II MULTI-PROCESS MONITOR--PROGRAMMER'S GUIDE

This manual contains information on programming in assembler language and, for the system programmer, explains how programs can interface with the MP/M II operating system. It has information useful to all assembly language programmers on the assembly language, the assembler, and RDT, the relocatable debugging tool.

The manual gives functional explanations of the modules of the operating system and how MP/M II monitors processes.

MP/M II MULTI-PROCESS MONITOR--SYSTEM GUIDE

This manual explains the system internal organization and how to customize MP/M II.

The manual is for system designers who wish to modify the user interface or the hardware interface to MP/M II. It assumes knowledge of the USER'S GUIDE and PROGRAMMER'S GUIDE. The manual includes information on the XIOS module which is used for basic input/output operations for your system.

The system overview at the beginning of the manual and the discussion of the GENSYS utility are useful to all users of the MP/M II system.

DOCUMENTATION CONVENTIONS

User input is in **bold face** when it is shown with system messages or in text. <CR> stands for Carriage Return, that is, for pressing the Return key. For example:

To execute the MPMSETUP program, enter:

ØA>MPMSETUP<CR>

In this example, the ØA> is generated by the operating system, and the bold-faced material is entered by the user.

Keys on the keyboard are referred to with leading capital letters when mentioned in text. For example:

Space Bar

Carriage Return Also shown as **<CR>**.

Control-P

Escape Appears as the **ESC** key.

Y or **N** Indicates a response from the user.

Control characters are used for certain functions. A control character, such as Control-P, is entered by holding down the control key (CTRL) while pressing the key, in this case, P. A control character may also be shown in <>s, such as **<Control-P>**. For example:

To print a directory, enter:

ØA>dir<Control-P><CR>

The brackets keys, [and], are actual keys used in entering certain options in MP/M II. For example, "When using the verification option with PIP enter **[V]**."

SCOPE OF THIS REVISION

Revision D of this manual pertains to MP/M II version 2.11SØ. It does not obsolete previous revisions of this document. In this version:

- 1) Installation is simplified,
- 2) Floppy format, full disk copy, and MPMSETUP are executed under MP/M II. Previously, they were executed under the Altos Diagnostic Executive (ADX).

- 3) Known bugs in XIOS and MP/M II have been corrected.
- 4) MPMSETUP has been improved by simplifying the user interface.
- 5) Disk performance improvements have been made.
- 6) X-ON (Control-Q) and X-OFF (Control-S) capabilities for serial printers is implemented.

SECTION 2.

INSTALLATION OF MP/M II

INTRODUCTION

The installation of MP/M II has been simplified in this release such that there are only three steps to execute if your system is configured with a hard disk and only two steps to execute if your system does not have a hard disk unit. To install MP/M II on your Series 5 or 580-10 system, execute the following steps:

1. Power-up your system and wait until prompted. The screen should display the following:

If your system has a hard disk.

Enter 1 to boot from hard disk
Enter 2 to boot from floppy disk

Insert the MP/M II master disk into floppy drive 1 (the right hand drive) and enter 2.

MP/M II will boot from the floppy drive and the following sign-on message will appear on the screen:

```
Altos MP/M II V2.11S0  
Copyright (C), 1982, Digital Research
```

```
0A>
```

If your system does not have a hard disk.

The following prompt will appear:

Booting From Floppy...

If a floppy disk containing the boot program was not inserted into the right-hand drive the following prompt will appear:

Insert Floppy Disk for Autoload.

Insert the proper disk and the system will boot automatically.

2. Enter the following after the system prompt:

`0A>INSTMPM <CR>`

The following message will then appear on the screen:

```
Altos series-5 installation program V1.0
-----
```

NOTE

**Anytime an error message is encountered,
see the ERROR HANDLING section below.**

SYSTEMS WITH A HARD DISK UNIT

1. Initialization and Configuration (Time: 15 minutes)

If your system is configured with one or more hard disks, this step will read the entire hard disk. The cylinder numbers of the hard disk will be displayed on the screen as they are being read. During the installation procedure, any bad sectors that are found on the hard disk are assigned alternate sectors that reside on cylinder 0. After the initialization is complete, the number of alternate sectors assigned will be displayed.

The above procedure is repeated for an add-on hard disk if your system has one.

The bootfile for the hard disk is also copied from the diskette during this process.

Next the configuration information about your system is displayed as follows:

```
Number of floppy drives = (1 or 2)
Primary hard disk capacity = (5Mb or 10Mb)
Add on hard disk capacity = (5Mb or 10Mb)
Number of users = 3
```

2. Installing MP/M II to hard disk (Time 15 minutes)

If your system has a hard disk the MP/M II files from your master floppy disk will be copied to the hard disk. This step

will also set up the default settings for your system (for example the first logical drive on the hard disk will be designated as drive A). The files that are copied to the hard disk are displayed on the screen.

3. Making a backup copy of the master MP/M II disk (Time 30 minutes)

This is an optional step in the installation procedure. The first prompt will ask the following:

Do you want to make a backup copy of the MP/M II diskette ? (Y/N)

If the response is "N" for No, the following message will appear on the screen:

MP/M II installation complete:

At this point MP/M II has been installed to hard disk. Press the reset button on the front panel. MP/M II will automatically boot from hard disk.

If the response is "Y" for Yes, then you will be asked to remove the MP/M II master disk from the floppy drive and insert a blank disk in the floppy drive. The blank disk will be formatted and the MP/M II files on the hard disk will be copied to the new floppy disk. The files that are copied will be displayed on the screen. After all the files have been copied the following message will appear on the screen:

MP/M II installation complete:

At this point MP/M II has been installed to hard disk and a backup copy of the MP/M master disk has been made.

Keep the original master disk in a safe place.

Press the reset button on the front panel. MP/M II will automatically boot from hard disk.

NOTE

During the installation process SETUP.FIL is modified on the backup diskette to reflect the new configuration. DO NOT delete this file since it is used to configure the system when MP/M II is loaded. Also, to re-install MP/M II always use the original distribution diskette.

SYSTEMS WITHOUT A HARD DISK UNIT

1. Initialization and configuration (Time: 15 minutes)

If your system does not have a hard disk unit then the configuration information about your system is displayed when you enter the INSTMPM command:

Number of floppy drives = (1 or 2)
Number of users = 3

2. Making a backup copy of the master MP/M II disk (Time 10 minutes)

This is an optional step in the installation procedure. The first prompt will ask the following:

Do you want to make a backup copy of the MP/MII diskette ? (Y/N)

If the response is "N" for No, the following message will appear on the screen:

MP/M II installation complete:

Although the installation is now complete, it is advisable that a copy of the MP/M II diskette be made as soon as possible.

If the response is "Y" for Yes, insert a blank diskette into floppy drive 2 (the left-hand drive). The blank disk will be formatted and the MP/M II files on the diskette residing in floppy drive 1 (the right-hand drive) will be copied to the new floppy disk. After the full disk copy is complete the following message should appear on the screen:

MP/M II installation complete:

At this point, a backup copy of the MP/M II master disk has been made. Place the original master disk in a safe place. The newly created diskette will be the working master. Insert this diskette into drive 1 (the right-hand drive). Press the reset button on the front panel. MP/M II will automatically boot from the new diskette.

NOTE

**During the installation process
SETUP.FIL is modified on the backup
diskette to reflect the new**

configuration. DO NOT delete this file since it is used to configure the system when MP/M II is loaded. Also, to re-install MP/M II always use the original distribution diskette.

ERROR HANDLING

During the installation procedure, a number of error conditions may cause the installation process to abort. The errors listed below mean that the hard disk has not been properly initialized.

- 1) Drive not ready.
- 2) Cylinder 0 is bad, cannot install MP/M to hard disk.
- 3) Too many bad sectors (34 is the maximum), cannot install MP/M to hard disk.
- 4) I/O error during hard disk initialization.

Other errors that are encountered are less severe, it is adviseable to check the MP/M II distribution diskette to pinpoint the problem.

NOTE

If installation is aborted for any of the above hard disk error conditions, it will not be possible to use the hard disk unit. Contact your dealer for details concerning repair or replacement of the hard disk.

LOGICAL DISK DRIVE ASSIGNMENTS

MP/M II organizes physical disk space into "logical" disk space. The system treats each logical drive as if it were an actual disk drive. Each logical drive consists of 5 megabytes and has its own directory of files. It is considered to be independent of other logical disk drives, even though more than one logical drive may occupy space on the same physical drive.

Logical disk assignments for hard disks for the Series 5 or the 580-10 under MP/M II are presented below. There are four possible configurations.

Number of Hard Disks -----	Number of Logical Drives -----
1) One Hard Disk	
A) 5 Megabyte	1

- B) 10 Megabyte 2
- 2) Two Hard Disks
 - A) two 5 Megabyte 3
 - B) two 10 Megabyte 4

When logical disk assignments are made, hard disk drives are always assigned before floppy disks. As a result logical drive "A" is always assigned to a hard disk unit (if one is configured into the system). As an example, a 5-10D system configured with a single 10 Megabyte hard disk drive and a single floppy disk drive will assign logical drives "A" and "B" to the hard disk and logical drive "C" to the floppy disk.

NOTE

Logical drive assignments can be changed using MPMSSETUP.

SECTION 3.

USING ALTOS MP/M II UTILITY PROGRAMS

MUTIL - UTILITY PROGRAM

This program allows you to format and copy entire 5-1/4 inch diskettes.

This program runs under MP/M II but should be used with caution. When this program is running all other users are denied access to any disk in the system.

To execute the program, enter the following after the system prompt:

ØA>MUTIL <CR>

The program will sign on as:

ALTOS MP/M II utility monitor v1.0

F. Format

C. Copy

Q. Quit

Type a letter to make your selection:

Format

When you choose the Format function the following is displayed:

Format will erase all files, do you wish to continue (Y/N).

Type "Y" to continue, "N" to abort.

Insert diskette to be formatted into available drive

Enter drive number (1/2) to continue

If you have two floppy drives, you can insert the diskette into drive 1 (right hand drive) or into drive 2 (left hand drive). If you have only one drive then you must insert the diskette into drive 1.

The cylinder numbers that are formatted will be displayed. After formatting is complete, the following message will appear:

Disk format complete.

After the disk has been formatted, the entire disk is verified. The verification operation can be aborted by pressing the escape key.

At the end of the verification control then returns to the main menu.

Copy

This is a full disk copy routine and requires at least two floppy drives. When you select the Copy function the following is displayed:

Insert diskette to be read from in drive 1

Insert diskette to be written to in drive 2

Press any key.

The track numbers will be displayed as they are copied. After copying is complete, the following message will appear:

Disk copy complete.

Control then returns to the main menu.

Quit

When you choose the Quit function control is returned to the operating system.

NOTE

The equivalent copy and format capabilities can also be accomplished by using the COPY and MFORMAT functions contained on the Altos Diagnostic Executive diskette.

MPMSETUP

Introduction

The MPMSETUP program is not part of the ordinary installation procedures. It allows some system changes to be made without running GENSYS, and also provides some procedures that GENSYS does not supply. For example, it allows the console and printer baud rates or default names for the logical drives to be changed. Drive A can be assigned to the hard disk instead of the floppy disk.

The following is a sample of the MPMSETUP display:

```
0A>MPMSETUP <CR>
```

```
ALTOS MP/M II Setup Utility (Series 5 or 580-10) -- Version 3.0  
-----
```

```
Copyright 1982 Altos Computer Systems  
Licensed by Altos for use on Altos systems only
```

```
Reading SETUP.FIL from disk A.
```

```
CURRENT SETUP
```

```
System has parallel printer as #0, serial printer is #1
```

```
Consoles:
```

```
  Console #1: 9600 BAUD  
  Console #2 and #3: 9600 BAUD
```

```
Disk Names:
```

```
  Physical floppy 1 is disk A  
  First Hard disk, first logical drive is disk E  
  Virtual disk is disk F  
-----
```

```
Functions:
```

P - Printer setup
N - Change default logical names
U - Update the setup file

C - Console baud rate setup
Q - Quit

Please select a function: [P]

MPMSETUP Functions

Before you run MPMSETUP, read the following information.

NOTE

The changes made with MPMSETUP do not take effect until the update function (menu selection U) is used. Changes are in effect when the system is again booted. If you exit from MPMSETUP without executing the update function, the system will remain unchanged. This is convenient in case of a mistake.

The following menu functions are provided. Note that default input to functions are contained in []. If you wish to use default values, simply press RETURN.

P - Printer Setup

Series 5 and 580-10 MP/M II version supports two printers, one serial and one parallel (Centronics or Centronics-type). The printers are numbered 0 and 1, and this function allows the user to specify which printer has precedence (low number).

N - Change Default Logical Names

This function allows you to choose the names for the various logical hard disk devices, floppy drives and virtual disk. Only one name per device is allowed and one of the names must be 'A'.

U - Update the Setup File

This function updates the Setup disk file with the changes that have been specified during the MPMSETUP session. To cancel the changes made during the session specify 'N' for No to the prompt:

Enter Yes to write SETUP.FIL, No to go to menu [Yes].

C - Console Baud Rate Setup

This function is used to set up the baud rates for the consoles. The baud rate values that are acceptable in this menu item are: 110, 300, 600, 1200, 2400, and 9600. The current baud rate setting is contained within [] and will remain unchanged by simply typing a RETURN.

Q - Quit

This function causes an exit from the MPMSETUP program. The prompt:

Normal Exit . . .

will be displayed prior to return to the MP/M II command level.

MPMSETUP Command Line Options

The disk drive that contains SETUP.FIL and the MPMSETUP functions can be specified on the command line. This allows the operator to either enter options more quickly or to put the options in a SUBMIT file.

The first option must be the drive letter (followed by a colon) for the disk that contains the SETUP.FIL. The other functions can be specified in any order, but the responses to the specific questions (e.g. baud rates) for a function must be specified in the correct order.

For example:

0A> MPMSETUP A: C 1200 300 U Y Q

This will read the SETUP.FIL from drive A and invoke menu item C (Console baud rate setup). It will then set console #1 to 1200 baud and console #2 to 300 baud. Next the SETUP.FIL on drive A will be updated. Note that this file is the MPMSETUP file. When the update is complete, the quit (Q) function will cause an exit from MPMSETUP. Control then returns to the MP/M Operating System command level.

NOTE

Even though MPMSETUP can read SETUP.FIL from any disk, SETUP.FIL must reside on disk A when the system is booted.

DISKSTAT

DISKSTAT generates information about floppy and hard disk I/O errors. It should be used whenever I/O errors are suspected. This file also displays the device name and physical attributes.

A temporary error is an I/O error that is successfully completed during a retry. If, after nine retries, the error still exists, a permanent error is declared.

The error counts are cumulative from power-on until the system RESET button is pushed or power is turned off. Each time the system is turned on, the error counts are set to 0, and will increment any time an I/O error occurs.

The following is an example of DISKSTAT execution:

```
0A>DISKSTAT <CR>
```

```
ALTOS DISK STATUS v1.00
```

```
Drive(s) A Floppy 80 Cylinders, 2 Heads, 9 Sectors Per Track  
0 Temporary Errors, 0 Permanent Errors
```

```
Drive(s) B Hard Disk 153 Cylinders, 4 Heads, 17 Sectors Per Track  
0 Temporary Errors, 0 Permanent Errors
```

MODIFYING THE SYSTEM WITH GENSYS

The GENSYS program is described in the MP/M II SYSTEM GUIDE. The USER'S GUIDE gives some background information. To modify the system, read this information carefully.

Changing The System To One Or Two Users

Altos Series 5 and 580-10 systems are generally set up for three users. To configure your system for use by less than three users is fairly simple. However, the SYSTEM GUIDE should be read before attempting the change.

For convenience, a short explanation of how to change the system for one user or two users is outlined below. This is supplementary information and does not replace the information in the MP/M II SYSTEM GUIDE.

1. Bring up MP/M II and run GENSYS.
2. Only two items need to be changed. All other questions can be answered by pressing the RETURN key to confirm the default value shown.
3. The two entries that need to be changed are:

- a. "Number of TMPs (system consoles) (#3)?"
- b. "Number of User Memory Segments (#3)?"

If you wish to specify a two-user system, reply #2 to **BOTH** of these.

If you wish to specify a one-user system, reply #1 to **BOTH** of these.

Figure 3-1 shows a sample run of how GENSYS is used to change the system to a one-user system. It is a sample only, and some of the details and defaults may be different.

Virtual Disk

One reason to change the system to fewer users is that MP/M II can make available a virtual disk called disk E. This is a memory device of up to 96 kilobytes of storage capacity. If fewer than three banks of memory is used in the system, the remaining bank(s) are available for a virtual disk. The virtual disk has a capacity of 48 Kbytes for each bank not used by MP/M II. If three banks are in use, the virtual disk has zero bytes of storage.

This disk can be used as a real disk of the same capacity with one important exception. When the power is switched off, or when the power goes off unexpectedly, the contents of the disk are erased. A good use for the virtual disk is temporary storage for work files. These files would not normally be saved so the power off problem would not be noticed. When working with important information in virtual disk files, transfer a copy to an actual disk from time to time for security. The advantage of the virtual disk is that because all accesses to it are actually memory accesses, the disk is very fast.

NOTE

By using the MPMSETUP utility, the name of the disk can be changed. For example, it could be changed to disk M, for Memory.

GENSYS For A One Or Two Bank System

Figure 3-1 shows a sample run of GENSYS. <CR> stands for a carriage return entered by the user. The default options (shown inside parentheses) are entered by pressing the RETURN key. Only two items are changed, these are required to reconfigure from three system consoles to one and from three memory banks to one. These changes are flagged by ** at the right.

To change a two-console, two-bank system, enter #2 in place of #1

at the two places flagged.

NOTE
Resident System Processors

This note applies only for those users doing advanced system configuration. When including Resident System Processors, be careful that the base address of bank 0 does not go below 4000H.

```
0A>GENSYS <CR>
00:00:16 A:GENSYS .COM
```

MP/M II V2.1 System Generation
 Copyright (C) 1981, Digital Research

Default entries are shown in (parens).
 Default base is Hex, precede entry with # for decimal.

```
Use SYSTEM.DAT for defaults (Y) ? <CR>
Top page of operating system (FF) ? <CR>
Number of TMPs (system consoles) (#3) #1 <CR> **
Number of Printers (#2) ? <CR>
Breakpoint RST (07) ? <CR>
Enable compatibility attributes (Y) ? <CR>
Add system call to user stacks (Y) ? <CR>
Z80 CPU (Y) ? <CR>
Number of ticks/second (#60) ? <CR>
System drive (A:) ? <CR>
Temporary file drive (A:) ? <CR>
Maximum locked records/process (#16) ? <CR>
Total locked records/system (#32) ? <CR>
Maximum open files/process (#16) ? <CR>
Total open files/system (#32) ? <CR>
Bank switched memory (Y) ? <CR>
Number of user memory segments (#3) ? #1 <CR> **
Common logging at console (Y) ? <CR>
```

```
SYSTEM    DAT    FF00H    0100H
TMPD      DAT    FE00H    0100H
USERSYS   STK    FD00H    0100H
XIOSJMP   TBL    FC00H    0100H
```

Accept new system data page entries (Y) ? <CR>

```
RESBDOS   SPR    F000H    0C00H
XDOS      SPR    CE00H    2200H
```

Select Resident and Banked System Processes:

```
ABORT     RSP    (N)    ?    <CR>
MPMSTAT   RSP    (N)    ?    <CR>
SCHED     RSP    (N)    ?    <CR>
SPOOL     RSP    (N)    ?    <CR>
```

```
BNKXIOS   SPR    AE00H    1F00H
BNKBDOS   SPR    8B00H    2300H
BNKXDOS   SPR    8900H    0200H
TMP        SPR    8500H    0400H
LCKLSTS   DAT    7400H    0300H
CONSOLE   DAT    7300H    0100H
```

Figure 3-1. Sample GENSYS Run

```
Enter memory segment table:
Base, size attrib, bank (87,79,80,00) ? <CR>

MP/M II SYS  8700H  7900H  BANK  00
MEMSEG  USR  0000H  C000H  BANK  01

Accept new memory segment table entries (Y) ? <CR>

**GENSYS DONE**

0A>
```

Figure 3-1. Sample GENSYS Run (continued)

MP/M II DIRECTORY

To display the MP/M II directory, enter the SDIR command as outlined below:

```
OB>
OB>SDIR
00:31:59 B:SDIR .PRL
```

Directory For Drive B: User 0

Name	Bytes	Recs	Attributes	Name	Bytes	Recs	Attributes
ABORT	PRL	4K	5 Sys RO	ABORT	RSP	4K	5 Sys RW
ASM	PRL	12K	74 Sys RO	BACKUP	COM	24K	169 Sys RW
BNKBDOS	SPR	12K	81 Sys RW	BNKXDOS	SPR	4K	7 Sys RW
BNKXIOS	SPR	12K	82 Sys RW	CONSOLE	PRL	4K	4 Sys RO
DDT	COM	8K	42 Sys RW	DIR	PRL	4K	14 Sys RO
DISKSTAT	PRL	4K	14 Sys RO	DSKRESET	PRL	4K	5 Sys RO
DUMP	PRL	4K	6 Sys RO	ED	PRL	12K	68 Sys RO
ERA	PRL	4K	15 Sys RO	ERAQ	PRL	4K	29 Sys RO
FTP	COM	4K	20 Sys RW	FTP12	COM	4K	20 Sys RW
FTP24	COM	4K	20 Sys RW	FTP31K	COM	4K	20 Sys RW
FTP41K	COM	4K	20 Sys RW	FTP48	COM	4K	20 Sys RW
GENHEX	COM	4K	6 Sys RW	GENMOD	COM	4K	10 Sys RW
GENSYS	COM	12K	74 Sys RW	INSTMPM	COM	24K	166 Sys RW
LIB	COM	8K	56 Sys RW	LINK	COM	16K	122 Sys RW
LOAD	COM	4K	14 Sys RW	MPM	SYS	32K	254 Sys RW
MPMFLDR	COM	8K	62 Sys RW	MPMHDLDR	COM	12K	66 Sys RW
MPMLDR	COM	8K	45 Sys RW	MPMSETUP	COM	16K	121 Sys RW
MPMSTAT	BRS	8K	33 Sys RW	MPMSTAT	PRL	8K	33 Sys RO
MPMSTAT	RSP	4K	3 Sys RW	MUTIL	COM	16K	111 Sys RW
PIP	PRL	12K	77 Sys RO	PRINTER	PRL	4K	8 Sys RO
PRLCOM	PRL	4K	21 Sys RO	RDT	PRL	8K	50 Sys RO
REN	PRL	4K	19 Sys RO	RESBDOS	SPR	4K	29 Sys RW
RMAC	COM	16K	106 Sys RW	SCHED	BRS	4K	12 Sys RW
SCHED	PRL	4K	20 Sys RO	SCHED	RSP	4K	3 Sys RW
SDIR	PRL	20K	137 Sys RO	SET	PRL	8K	60 Sys RO
SETUP	FIL	4K	1 Sys RW	SHOW	PRL	8K	60 Sys RO
SPOOL	BRS	4K	20 Sys RW	SPOOL	PRL	4K	17 Sys RO
SPOOL	RSP	4K	5 Sys RW	STAT	PRL	12K	78 Sys RO
STOPSPLR	PRL	4K	5 Sys RO	SUBMIT	PRL	8K	42 Sys RO
SYSTEM	DAT	4K	2 Sys RW	TMP	SPR	4K	11 Sys RW
TOD	PRL	4K	20 Sys RO	TYPE	PRL	4K	11 Sys RO
USER	PRL	4K	8 Sys RO	XDOS	SPR	12K	79 Sys RW
XREF	COM	16K	121 Sys RW				

```
Total Bytes = 516K Total Records = 2938 Files Found = 65
Total 1k Blocks = 400 Used/Max Dir Entries For Drive B: 65/ 177
```

OB>

To print a file directory, enter the command outlined below:

ØA>SDIR [CONTROL] P

and press the RETURN key. To enter a [CONTROL] P, hold down the CTRL key and press P, then release both. After the directory is printed, enter another [CONTROL] P and press the RETURN key. (Otherwise, whatever shows on the console prints.) For additional information on [CONTROL] P, see the MP/M II User's Guide.



Series 5 Computer System

Altos Diagnostic Executive (ADX) Manual

Revision E
November 15 , 1982



**SERIES 5 COMPUTER SYSTEM
DIAGNOSTICS MANUAL
REVISION E**

This revision replaces but does not obsolete previous versions of this document. The information contained herein is subject to change without notice. Changes will be incorporated in new editions of the document as they are published.

**Copyright © 1982
Altos Computer Systems. All rights reserved.**

Table of Contents

Section 1. ADX PROGRAM DESCRIPTION

GENERAL INFORMATION	1-1
ADX PROGRAM FUNCTIONS	1-1
ADX UTILITY PROGRAMS	1-2
ADX TEST PROGRAMS	1-2
BOOTING FROM FLOPPY OR HARD DISK	1-2
KNOWN DEFICIENCIES	1-2

Section 2. LOADING AND RUNNING ADX

INTRODUCTION	2-1
BOOTING THE ADX PROGRAM	2-1

Section 3. MAKING BACKUP COPIES OF ADX

ADX COPIES WITH THE SERIES 5-5D	3-1
ADX COPIES WITH THE SERIES 15D	3-4

Section 4. ADX UTILITY PROGRAMS

INTRODUCTION	4-1
MFORMAT	4-1
COPY	4-2
BOOTCOPY	4-3
ADXSETUP	4-3

Section 5. ADX TEST PROGRAMS

INTRODUCTION	5-1
TEST RAM USING MEMTEST	5-1
TEST PRINTER INTERFACE USING PRNTEST	5-3
TEST FLOPPY DISKETTE DRIVES USING MFT	5-3
Running MFT	5-4
Displaying Errors	5-4
Continuously Write a Sector	5-6
Continuously Read a Sector	5-6
Reliability Test	5-6
Continuously Write then Read One Track	5-6
Motor Start Timing Test	5-6
Exit Program	5-6
TEST HARD DISK DRIVE USING HARDS5	5-7
Format Disk Drive	5-8
Seek Test with Optional Verify	5-9
Write Entire Disk	5-9
Read Entire Disk	5-10
Option Descriptions	5-10
Set Flag Byte for a Specific Sector	5-11
Hard Disk Read/Write Error Test	5-12
Miscellaneous Functions	5-14

SECTION 1**ADX PROGRAM DESCRIPTION****GENERAL INFORMATION**

This manual provides the necessary instructions for the execution of Altos diagnostic programs. These utility and test programs prepare the Series 5 computer for the installation of an operating system and for selected application programs. This program must be run the first time the computer system is powered up, and each time a new component is added to the system.

ADX PROGRAM FUNCTIONS

The ADX master diskette provided with the system contains a group of command programs that format and copy floppy diskettes, copy boot tracks, and test Series 5 computer system components. These programs comprise the Altos Diagnostic Executive Program (ADX).

CAUTION

A back-up copy of the ADX master should be made before proceeding to test system components. To protect the master diskette, at least two copies should be made. One copy, the ADX system diskette, is for daily use. The other, the back-up master, is used for making additional copies for daily use. The ADX master diskette is not for daily use but should be stored, together with the back-up masters, in a secure location away from the computer to prevent accidental use.

ADX UTILITY PROGRAMS

The ADX program uses five utility programs to prepare the Series 5 computer for operation. They are:

- MFORMAT - which formats floppy disks for all models of the Series 5.
- BOOTCOPY - which copies boot tracks.
- COPY - which copies floppy disks including boot tracks if on the disk.
- ADXCOPY - which copies ADX onto a formatted floppy disk.
- ADXSETUP - which specifies and updates baud rates for the console terminal, printer, and auxiliary port.

ADX TEST PROGRAMS

The ADX program uses four utility programs to test the Series 5 computer components for operation. They are:

- MEMTEST - which tests RAM.
- PRNTEST - which tests the printer interface.
- MFT - which tests floppy disk drives.
- HARDS5 - which tests hard disk drives.

BOOTING FROM FLOPPY OR HARD DISK DRIVES

There are two methods of bootstrapping available with the Series 5 computer system. One is booting from a floppy diskette and the other from a hard disk. When booting from a floppy diskette, regardless of the type/model of Series 5 computer, it is necessary to use the right-hand (RH) floppy disk drive.

KNOWN DEFICIENCIES

At the time this manual was printed, the below listed system deficiencies were known to exist.

1. After loading and running ADX, the self-test sometimes runs spontaneously when the system is re-booted.

SECTION 2

LOADING AND RUNNING ADX

INTRODUCTION

This section presents the loading and running of the Altos diagnostic program. It describes the booting of ADX and the display of the ADX directory.

BOOTING THE ADX PROGRAM

- Step 1. Make sure that computer is ON. If not, power up the computer system as outlined in the Series 5 User Manual.
- Step 2. The system will display the following message and prompt on the screen.

If the system is configured with a hard disk unit the following appears:

```
ALTOS COMPUTER SYSTEMS  
MONITOR VERSION 7.02
```

```
Self test completed
```

```
Press any key to interrupt Boot operation  
Booting from Hard Disk.....
```

```
Selected device does not contain Boot program
```

```
Enter 1 to Boot from Hard Disk  
Enter 2 to Boot from Floppy Disk
```

Go to step 3. below to continue the loading process.

If the system is configured without a hard disk unit

the following appears:

**ALTOS COMPUTER SYSTEMS
MONITOR VERSION 7.02**

Self test completed

Booting From Floppy Disk . . .

If a floppy disk containing the boot program was not inserted into the right-hand drive the following prompt will appear:

Insert Floppy Disk for Autoload.

Go to step 4 below.

Step 3. Enter 2 to boot from the floppy disk. The ADX program cannot be booted from hard disk. The system will display the following message:

**2
Booting from Floppy Disk.....**

Insert Floppy Disk for Autoload

Step 4. Insert Master ADX diskette. The system will display the ADX directory and the REQUEST prompt on the screen as shown below.

Altos ADX 3.00

ALTOS DIAGNOSTIC MONITOR VERS 3.1

*** * * DIAGNOSTIC COMMAND DIRECTORY * * ***

ADXCOPY	COPY	BOOTCOPY	MFT
MENTEST	PRNTEST	HARDS5	MFORMAT
ADXSETUP			

REQUEST:

Step 5. Proceed to one of the sections listed below and select the desired utility/test program.

- Section 3 - Making Back-up Copies of ADX
- Section 4 - ADX Utility Programs
- Section 5 - ADX Test Programs

SECTION 3

MAKING BACK-UP COPIES OF ADX

ADX COPIES WITH THE SERIES 5-5D

Have at least two new blank 5-1/4 inch floppy diskettes. These should be 80 track (at 96 tracks-per-inch), double-density, double-sided, soft-sectored diskettes.

- Step 1. With the ADX Master diskette loaded and the Diagnostic Command Directory menu displayed, enter MFORMAT after the REQUEST prompt. The terminal will display the following:

```
ALTOS 5-1/4 INCH FLOPPY FORMAT FACILITY__V 1.1
Insert diskette to be formatted in available drive
Remove system disk if necessary
Enter drive letter to continue      A/B?
```

- Step 2. Insert blank diskette in right-hand drive and type A. The system will respond by counting the diskette cylinders as they are formatted as shown below:

```
Cylinder  XX      (where XX is a cylinder number from
                  0 to 79)
```

- Step 3. After completing the format for cylinder 79 the utility will verify the format task as shown below:

```
Disk Format Complete
Press Any Key to Abort Verifying
Verifying Cylinder  XX      (where XX is a cylinder
                             number from 0 to 79)
```

If you allow the verification to go to completion you will see the following message:

```
Verify Complete
```

Would you like to format another diskette? Y/N

Step 4. At this point remove the diskette from the drive and label it "ADX Back-up Master" and set it aside.

WARNING

Use only felt tip pens when writing on a floppy diskette. The use of a pencil or a ball point pen can make indentations on the surface of the diskette and will cause media related errors during use. Preferably prepare and write on the label before it is placed on the diskette.

Step 5. To make the "ADX System Diskette", the one to be used in daily use, insert the second blank diskette and type Y to the prompt shown in step 3 above. The prompt shown in step 1 above will be repeated, respond in the same manner as before. Upon completion, remove diskette and label it properly.

Step 6. Respond with a N to the prompt in step 3 to exit the MFORMAT utility. The next prompt will then be displayed:

**System disk in drive A
Enter to continue.....**

Step 7. Insert the ADX Master diskette and depress the return key on the keyboard of the terminal. Control will then return to the Diagnostic Command Directory.

Step 8. Type "ADXCOPY" after the "REQUEST" prompt. The following prompt appears:

ALTOS ADX Disk Copy Program -- Version 1.0

Please insert diskette to be read from

Then press return key

Step 9. Press the return key. The system will respond by counting the diskette cylinders as they are read as shown below:

Reading cylinder XX (where XX is a cylinder number from 0 to 79)

Note

The ADXCOPY procedure when used with a single diskette system (5-5D) will read as many cylinders as possible from the source disk into memory and will then write those files to cylinders on the destination diskette that has been inserted into the drive. Because there is a limit to the number of cylinders of information that can be placed into memory at one time, it may be necessary to read only part of the source disk into memory and then write that information out to the destination disk. It may require as many as five iterations of this procedure to fully copy a disk. In the event that memory cannot hold the full contents of the disk in one execution of the procedure, the system will direct you to insert the destination disk to which you want to write for a partial copy. You should proceed to step 10 below. When you have completed steps 10-12 you can return to step 8 to continue copying from the source disk at the cylinder number where the copy process was temporarily halted.

- Step 10. After the maximum numbers of cylinders have been read the following prompt will appear:

Please insert diskette to be written to

Then press return key

- Step 11. Remove the ADX Master diskette from the drive, insert the formatted diskette labelled "ADX Backup Master". Press the return key. The system will respond by counting the diskette cylinders as they are written to as shown below:

Writing cylinder XX (where XX is a cylinder number from 0 to 79)

- Step 12. After all cylinders have been written to the following prompt will appear:

Do you want to copy another diskette? (Y/N)

If you enter a "Y" for yes, the original prompt in step 8 above will be repeated.

If you enter a "N", control passes back to the diagnostic menu.

ADX COPIES WITH THE SERIES 5-15D

Step 1. Enter COPY after the REQUEST prompt. The terminal displays the following:

Altos 5-1/4 Inch Disk Copy Program-- V 1.1

Insert diskette to be read from in drive A

Insert diskette to be written to in drive B

Type return

Step 2. Make sure that the ADX Master diskette is in the right hand drive (drive A). Insert the formatted diskette labeled ADX Back-up Master in the left hand drive (drive B) and then depress the return key on the keyboard of your terminal.

Step 3. When copy is finished, it returns back to the Diagnostic Command Directory. Remove the diskette. Repeat the COPY operation for the second diskette.

NOTE

This utility copies boot tracks as well.

NOTE

At this point store the original ADX Master diskette in a safe place away from the system work area. DO NOT USE THIS DISKETTE EXCEPT TO CREATE ADDITIONAL ADX BACK-UP MASTERS, AND ONLY USE THE ADX BACK-UP MASTERS TO CREATE ADX SYSTEM DISKETTES! The back-up procedure for Series 5-15D systems is now complete.

Step 4. Upon completion, remove the diskette from the drive and label it ADX System Master. Repeat the COPY procedure to make a copy of the ADX System Diskette. Do not use the ADX Master, set it aside and use the ADX Back-up master in its place.

SECTION 4

ADX UTILITY PROGRAMS

INTRODUCTION

This section describes the four utility programs that are a part of the Altos diagnostic program (ADX).

MFORMAT

The MFORMAT utility program either formats or reformats diskettes. This program erases all data stored on an old diskette.

Step 1. Insert the diagnostic diskette in the diskette drive. Push the system reset button. The ADX Diagnostic menu is displayed on the terminal screen. Enter MFORMAT after the REQUEST prompt. The terminal displays the following:

```
ALTOS 5-1/4 INCH FLOPPY FORMAT FACILITY -- V 1.1
Insert diskette to be formatted in available drive
Remove system disk, if necessary
Enter drive letter to continue          A/B?
```

Step 2. Insert the blank disk into the desired drive and close the loading door. Type A for the right hand side drive or B for the left hand side floppy disk drive (Series 5-15D only). The system responds by counting the diskette cylinders as they are formatted as shown below:

```
Cylinder XX      (where XX is a cylinder number from
                  0 to 79)
```

Step 3. After completing the format for cylinder 79 the utility will verify the format task as shown below:

Disk Format Complete
Press Any Key to Abort Verifying

Verifying Cylinder XX (where XX is a cylinder number from 0 to 79)

If you allow the verification to go to completion you will see the following message:

Verify Complete

Would you like to format another diskette? Y/N

- Step 4. At this point, remove the formatted diskette from the disk drive, label it, enter Y for Yes to repeat, or N to return to the ADX Diagnostic menu.

COPY

COPY performs a sector by sector copy of a 5-1/4 inch diskette. This utility requires two floppy disk drives, therefore it can only be used on the Series 5-15D computer system. The COPY utility requires a source and a previously formatted object diskette to be copied.

- Step 1. Load the ADX Diagnostic diskette into drive A. Press the system reset. The ADX Diagnostic menu displays on the terminal screen. Enter COPY after the REQUEST prompt. The terminal displays the following:

ALTOS 5-1/4 Inch Disk Copy Program -- V1.1

Insert diskette to be read from in drive A

Insert diskette to be written to in drive B

Type return

- Step 2. Remove the ADX diskette and insert the diskette to be copied in the right hand drive (drive A). Insert the formatted object diskette in the left hand drive (drive B) and then depress the return key on the keyboard. The system responds by displaying the diskette cylinders as they are copied as shown below:

Copying Cylinder XX (where XX is a cylinder number from 0 to 79)

- Step 3. After completing the copy, the utility will prompt for repetition of the copy task. Remove the source and object diskettes. Type Y, for Yes, to repeat copying or type N to return to the Diagnostic Command

Directory. This copy utility copies all areas on the disk, including the boot tracks.

BOOTCOPY

The BOOTCOPY program is designed for the Series 5 computer system. It copies the autoboot system tracks (0 and 1) from a source disk, to any object disk that has already been formatted.

Follow the procedure below to execute the BOOTCOPY program.

- Step 1. To perform the BOOTCOPY program, the diagnostic disk, a source disk, and an object disk are required.
- Step 2. Insert the ADX diagnostic diskette in the right-hand diskette drive. Depress the system reset button. The ADX Diagnostic menu displays on the terminal screen. Enter BOOTCOPY after the REQUEST prompt. The terminal displays the following:

ALTOS 5-1/4 Inch Boot Copy Program -- V1.1

Insert diskette to be read from in drive A
Press return key

After the diskette has been read, the next prompt is given:

Insert diskette to be written to in drive A
Press return key

Do you want to repeat, (Y/N)

- Step 3. After completion of the boot copy the system returns back to the ADX Diagnostic menu if the reply is N (No).

ADXSETUP

- Step 1. This utility is used to specify baud rates for the console terminal, printer and auxiliary port. After the screen displays the command menu, select ADXSETUP as follows:

REQUEST: ADXSETUP (Depress return)

The screen displays the following:

ALTOS COMPUTER SYSTEMS

DIAGNOSTIC DISK

BOOT SETUP PROGRAM, VERSION 3.00

SELECT BAUD RATE FROM FOLLOWING LIST FOR CONSOLE #1

- 0 DON'T CHANGE CONSOLE BAUD RATE
- 1 110 BAUD
- 2 300 BAUD
- 3 600 BAUD
- 4 1200 BAUD
- 5 2400 BAUD
- 6 4800 BAUD
- 7 9600 BAUD

Specify baud rate:

- Step 2. Select the baud rate applicable to your terminal by the list item number. The Altos system requires that console #1 have a 9600 baud rate. After making a selection, depress return.

The next display is to determine the baud rate for consoles #2 and #3. Since these consoles are not presently used by ADX, select 0 and depress return.

The next display prompts to select the baud rate for the printer as follows:

SELECT PRINTER BAUD RATE FROM FOLLOWING LIST

- 0 CENTRONICS TYPE PRINTER (PARALLEL PORT)
- 1 110 BAUD
- 2 300 BAUD
- 3 600 BAUD
- 4 1200 BAUD
- 5 2400 BAUD
- 6 4800 BAUD
- 7 9600 BAUD

Specify baud rate:

- Step 4. Select the applicable baud rate for the printer you are using with your system by list item number. Please note that if you are using a Centronics printer which is operating as a parallel device as opposed to a serial connected printer, then you will select 0. If, however, you are using a Centronics which is serially connected, select the applicable baud rate. You may need to consult the operators manual for the printer to determine this specification. Make your selection and depress return.

The user is now prompted to place the disk to be updated in drive A as follows:

**PLACE DISK WITH BOOT TO BE UPDATED IN DRIVE A.
 REMOVE SYSTEM DISK IF NECESSARY
 Hit <CR> when ready to proceed:**

- Step 5. If you are updating the diagnostic disk presently being used, then depress return. If it is another copy of the diagnostic disk and it requires an update, then remove the diagnostic disk presently in use and place the disk to be updated in drive A.

Once the disk to be updated is in drive A, close the loading door and depress return. The following is displayed:

**ADX BOOT SECTOR SUCCESSFULLY UPDATED
REPLACE SYSTEM DISK IN DRIVE A:
HIT <CR> WHEN READY**

- Step 6. If the updated diagnostic disk was used to perform this operation, then depress the system reset button on the front panel to reset the system. This is to reinitialize the system with the updated information.
- Step 7. If the updated diagnostic disk is not the diagnostic disk being used, then place that diagnostic disk in drive A and depress return.

SECTION 5**ADX TEST PROGRAMS****INTRODUCTION**

This section describes the four test programs that are a part of the Altos diagnostic program (ADX).

These tests should be run if:

- 1) problems with the floppy diskette drives, hard disk, printer, memory, or the CPU PCB are encountered,
- 2) the system is first setup, or
- 3) new components are added to the system.

You should run ADX test programs in the following order to test and initialize system components. Refer to the next subsection for test program descriptions and operating procedures.

1. Run MEMTEST to test computer system RAM.
2. Run PRNTEST to test the printer interface.
3. Run MFT to test computer system floppy disk drives.
4. Run HARDS5 to test the computer system hard disk, if your Series 5 system has a hard disk.

The ADX program may include other programs depending upon how your system is configured.

TEST RAM USING MEMTEST

The MEMTEST command allows you to test all but a small portion of system RAM for possible errors. Since the program itself occupies some memory, that portion cannot be tested.

Follow this procedure to run MEMTEST.

- Step 1. Insert the diagnostic diskette into drive A.
- Step 2. Boot up the system. You will see the diagnostic menu.
- Step 3. Type MEMTEST following the REQUEST: prompt.

The screen will display the following:

ALTOS SERIES 5 MEMORY TEST VERSION 2.4

**VALID TEST MEMORY RANGE (HEX)
COMMON AREA C000 - FFFF
BANKS 0-2: 0000-BFFF; BANK 3: 4000-BFFF
SELECT MEMORY BANK TO BE TESTED**

**TEST ALL BANKS? (YES=Y: NO=N)
USER DEFINED TEST PATTERN (Y OR N)
DEFINE PATTERN:**

**TEST ALL MEMORY? (YES=Y, NO=N)
OF PASSES TO RUN:
HALT ON FIRST ERROR? (YES=Y, NO=N)
SPECIFY MAXIMUM # OF ERRORS ALLOWED:
RUN ALL SIX TESTS (YES=Y, NO=N)**

- Step 4. You will be prompted four times to select a memory bank. If you wish to select only one memory bank, select bank, 0,1,2, or 3, and depress RETURN. Also, press RETURN to bypass subsequent memory bank select options. You will now receive the following screen display.

**STARTING ADDRESS (HEX)?
ENDING ADDRESS (HEX)?**

- Step 5. Refer to matrix maps for memory address selections. Memory test range is given in the screen display above. Select the starting and ending addresses and depress RETURN after each selection.

Memory testing will now begin. The screen will display the following prompt as it tests:

123456	PASSES -	1	ERRORS -	0
123456	PASSES -	2	ERRORS -	0

ALL DONE, WAITING FOR CONSOLE INPUT.....

Enter one of the following options.

TYPE L TO GET A LIST OF VALID COMMANDS
 TYPE C TO GET CURRENT CONTROL WORD
 TYPE L TO GET LIST OF ALL COMMANDS
 TYPE S TO PRINT TEST SUMMARY
 TYPE R TO RESTART THE TEST
 TYPE P TO RESTART WITHOUT CHANGING ANY PARAMETERS
 TYPE H TO HALT TESTING

- Step 6. If you wish to stop the test without terminating it, and see the results, depress S (SUMMARY) on the keyboard and the results will be displayed. Press R (RESTART) on the keyboard if you wish to terminate the test, see the results, and select another memory bank.

Depress the system reset button to return to the diagnostic menu.

- Step 7. Replace any defective memory chips with 64KX1 dynamic RAM 200 nanosecond access time. The chip you select must support a refresh cycle by performing a RAS only cycle at each of 128 row addresses every 2 milliseconds or 128 cycles. Chips that require 256 refresh cycles cannot be used. 64K RAM chips from Okidata and Motorola have been qualified for use in a Series 5 computer.

TEST PRINTER INTERFACE USING PRNTEST

- Step 1. Select PRNTEST after the REQUEST: prompt from the diagnostic command directory. This command causes the following characters to be displayed on the terminal and to be printed on the printer when the printer is connected.

PRINTER TEST X.X

```
!"#$%&'()*+,-./
0123456789:;<=>?
@ABCDEFGHIJKLMNO
PQRSTUVWXYZ[\]^_
`abcdefghijklmno
pqrstuvwxyz{|}~
```

A parallel printer can be specified by using ADXSETUP.

TEST FLOPPY DISKETTE DRIVES USING MFT

The ADX MFT test program package tests the computer's floppy disk drive system. It consists of seven tests. Run various test programs in this package if you suspect that you have a hardware

driven problem with your system.

Running MFT

You will need one formatted blank diskette for Series 5-5D (two for Series 5-15D) to use MFT. Using diskettes that are known to be good, format the diskettes on the drive to be tested using MFORMAT. Then run MFT function test C (listed on the MFT main menu) for at least 400 passes, if possible. There should be fewer than one error per pass.

If the number of errors per pass is greater than one, terminate the test and try new and different floppy diskette, to ensure that you do not have defective media.

To run this test, insert the ADX copy diskette into logical drive A and depress the reset button. The diskette will boot up automatically, and display the Diagnostic Commands Directory. First, type MFORMAT after the REQUEST: prompt to format a blank diskette. Return to the Diagnostic commands directory after formatting a diskette, and type MFT after the REQUEST: prompt.

The MFT Main menu displays in a few moments. It prompts you to choose which floppy disk drive function to be tested. The most useful choice to make in most field situations is Option C, RELIABILITY TEST, but other tests on the menu may also be chosen. The RELIABILITY TEST should be run for one or two hours if possible; most other tests on the menu will take less time. All tests display screen prompts to guide you clearly through simple operating procedures. Do not use diskettes that have good data on them for any tests.

Type S on the keyboard to generate a summary error display at any time during any function test you select in this program.

Type ESC to abort any function test at any time.

*****ALTOS 5.25 INCH FLOPPY TEST FACILITY*****

- a) Continuously write a sector
- b) Continuously read a sector
- c) Reliability test
- d) Continuously write then read one track
- e) Motor start timing test
- f) Exit program

Test C above is best used for Acceptance Test procedures when first verifying system operation or component additions.

Displaying Errors

All MFT function tests seek, find, and report errors in the floppy disk system. Error information can be displayed in two different tables: The ERROR SUMMARY TABLE and the ERROR DISPLAY TABLE.

Type the letter S to call the error summary table. It can be called at any time from any function test on the MFT main menu. The error summary table tallies errors as an individual test accumulates them. The summary table will not interrupt the test you are running.

Here is a list of error code definitions and suggested problem sources for the Error Summary Table.

1. **CRC -- Cyclic Redundancy Check.** This error type shows that you are probably losing data integrity between the controller and the floppy diskette.
2. **RNF -- Record Not Found.** The sector address holding test data cannot be located.
3. **SKV -- Seek/Verify Error.** Unable to verify track number after seeking.
4. **CMP -- Compare Error.** Losing data integrity between the floppy disk controller and volatile system memory.

In general errors 1, 2, and 3 are often associated with defective media. Error 2 sometimes arises due to an unformatted disk.

The following screen display is listed when you specify the error summary table. You may display the errors if desired.

	DRIVE A				DRIVE B			
	CRC	RNF	SKV	CMP	CRC	RNF	SKV	CMP
SOFT	0	0	0	0	0	0	0	0
HARD	0	0	0	0	0	0	0	0

Do you wish to display errors? Y/N

The error display table is selected by answering Y (Yes) to the prompt that appears at the bottom of the error summary table. It shows error types and the physical locations of errors on the diskette. It is best called toward the end of a test.

SOFT ERRORS

DRIVE	SIDE	TRACK	SECTOR	ERROR	PASS	OCCURRENCES
1	0	23	4	CMP	0	2

Continuously Write a Sector

Enter A to select this first test. It prompts you first to enter the Drive, cylinder, head and sector number to be written to, and then to insert a formatted test diskette into the drive to be tested.

Continuously Read a Sector

Enter B to select this test. It prompts you first to enter the drive, cylinder, head and sector number to be read from, and then displays the contents of the sector. It then asks if you'd like a dump of the read buffer on a CRC or Compare error.

Reliability Test

Enter C to select this test. Test accuracy increases greatly with the number of passes it has time to make over the test diskette. It should run for a few hours on a normal system.

It first prompts you to select drive A or B, and then to insert a formatted test diskette in the drive number selected. Next, it displays the Reliability Test Screen and begins to conduct a read/write error test. It displays errors in a table similar to the Error Display table.

Continuously Write Then Read One Track

Type D to select this test. It first prompts you to select drive, cylinder and head numbers, and then to insert a formatted test diskette in the drive number selected. It displays errors in a table similar to the Error Display table.

Motor Start Timing Test

Enter E to select this test. This test prompts you to place a formatted diskette in drive A. The test turns the motor on and off constantly to verify that it is operating correctly. Press ESCAPE key to terminate the test.

EXIT Program

All function programs return to the MFT main menu when finished. Exit MFT by selecting option f., exit program.

TEST HARD DISK DRIVE USING HARDS5

HARDS5 tests computer system hard disks. It consists of eight tests. To run this test, load the ADX diskette and type HARDS5 after the REQUEST: prompt. The screen displays the following status message:

```

***Hard Disk (5-1/4") Test Facility X.X***
Specify Configuration of HARD DISK to be tested.
Default Configuration is:
Drive Number           :    1
Cylinders Per Drive    :   153
Number of Heads        :    4
Sector Size            :   512
Press RETURN to bypass a selection.
Enter Drive Number ("1" or "2")           <cr>  **
    
```

Note: ** enter 2 if testing an external drive.

Respond by specifying the conditions under which you will run the hard disk tests or functions. The following prompts will appear.

```

Enter cylinders per drive ("1" = 153; "2" = 306)      <cr>
Enter number of heads    ("2", "4", "6", or "8")      <cr>
Enter sector size        ("1" = 256; "2" = 512)      <cr>
    
```

```

***Hard Disk (5-1/4 ") Test Facility X.X***
    
```

1. Format Disk Drive
2. Verify Addresses for all Sectors on Disk
3. Seek Test with Optional Verify
4. Write Entire Disk
5. Read Entire Disk
6. Set Flag Byte for a Specific Sector
7. Hard Disk Read/Write Error Test
8. Miscellaneous Functions
9. Terminate this Test Series

Select required function by number:

Normally run test 7 at the time the computer system is powered up and each time a new component is added to the system.

Also note that test 2 is non-destructive and is therefore recommended for use when a quick overall check is desired. Tests 1, 4, 6, and 7 are destructive of data and track IDs.

Format Disk Drive

This function formats each sector on the hard disk drive. This function will erase flag byte indications of bad sectors (obtained from the Seagate error map provided with each computer) and all data. Sectors previously marked as bad will now be marked as valid. Unless these sectors are re-marked as bad sectors, data written on these bad sectors will be lost.

WARNING

This HARDS5 function erases data on the hard disk and will cause loss of user data.

Once you have selected test 1 and depressed RETURN, the screen will display the following:

*****DO NOT RUN THIS TEST WITHOUT PERMISSION FROM -ALTOS-CUSTOMER SERVICE***
Call 408 946-6700**

Do you want to continue?

This function will destroy user data. Password entry is used as a safeguard to protect the system and the data it stores. You can obtain this password from your distributor or from Altos Customer Service. (Contact your distributor first.)

Before a password is given to you, an attempt will be made to continue. If you enter N and depress RETURN, you will return to the hard test selection menu.

Enter your password and depress RETURN. The screen will display the following.

*****THIS TEST WILL ERASE FILES ON THE HARD DISK*****

Do you want to continue? (y or n):

Type Y and depress RETURN to continue. The format process will begin and you will see a count from 0 to 152 appear on the screen as each cylinder is formatted. The program returns to the hard disk menu when formatting is completed, and you will be prompted to make a new selection.

REMEMBER: You have formatted the disk, but you have not flagged any bad sectors. This should be done before any attempt is made to transfer user data to the hard disk.

Verify Addresses for all Sectors on Disk

Type 2 [RETURN] to select this test. The screen will display the following.

Press any key when "ready" to start this test

You will see a count displayed at the bottom left corner of the screen as the tracks are checked. Any bad sectors encountered which have been flagged as bad will cause a BAD SECTOR display. Any bad sectors encountered which have not been flagged earlier as bad will possibly cause a CRC error display. Once completed, the screen will display the hard disk test menu again.

You will be prompted to select which hard disk test or function you wish to perform.

Seek Test with Optional Verify

This test seeks between two operator specified cylinders and can verify the addresses at head 0, sector 0, of each specified cylinder.

Type 3 [RETURN] to select this test. The screen displays this prompt.

Press any key when "ready" to start this test

The program then prompts you to specify a low cylinder and a high cylinder to set the test boundary. For maximum boundary limit, select cylinder 0 and cylinder 152. For minimum boundary, specify cylinder 0 and cylinder 1. Specify any appropriate low/high cylinder combination.

The program then prompts you to set the verification flag on the test loop. To the operator it doesn't appear to make any difference whether Y or N is selected, the cylinder numbers will be displayed as the seek is performed, but if Y is selected the logic of the system reads data for each cylinder. With Verification selected, a BAD SECTOR display will be generated if any bad sector that has been flagged is encountered. If the head 0 and sector 0 address of the specified cylinder has not been previously flagged as a bad sector, and the I.D. block for that sector is bad, a RECORD NOT FOUND display will be generated. The system may not be performing the seek operation properly. To verify that SEEK is performing properly, select another cylinder.

Write Entire Disk

This function writes a two-byte character to the data block for each track of the disk. This character can be selected by the operator.

Type 4 [RETURN] to select this test. Answer Y at this warning prompt to continue.

*****THIS TEST WILL ERASE FILES ON THE HARD DISK*****

Do you want to continue? (y or n):

The test asks if you want to specify a write-pattern. Enter Y

[RETURN] to specify a pattern. You will be prompted to select the pattern you wish to use.

If you have no specific pattern, enter N [RETURN]. The system will then write its own character, E5H, on the disk. You will see the count, track by track, as it writes to the disk. The final error display can vary depending upon these four write situations.

1. Writing to a flagged bad sector will cause a BAD SECTOR display.
2. Writing to a unflagged bad sector may cause a CRC error display if the ID block and CRC bytes are also bad.
3. Writing to a unflagged bad sector with a bad ID block will generate a RECORD NOT FOUND display regardless of the condition of the CRC portion of that ID block.
4. A bad sector with a bad data block by a good ID block will not generate an error display. A READ test will detect this error condition.

Read Entire Disk

This function reads each sector of each track of the hard disk. The test uses a memory buffer area. The program writes FFH hex into the memory buffer before beginning the read process. As each sector is read into this buffer, the contents of that sector will be written over the FFH hex number that is located there.

FFH hex is again written to the memory buffer, and the next sector writes over FFH a second time. This "flushing" of the memory buffer is done to ensure that the contents of each sector are read accurately.

Type 5 [RETURN] to select this test. This menu of display options screens.

Hard disk read display options are:

1. DO NOT display data if any error
2. Display data only if a STATUS error
3. Display data only if a COMPARE error
4. Display data if a STATUS or COMPARE error

Select option by number:

Option Descriptions

1. Option #1 runs the test but does not display the contents of the data block nor any status or compare errors.
2. Option #2 will cause the hard disk controller to send

back status errors when the controller is unable to locate and properly identify a sector. The data block is passed unchecked but the program will check the CRC portion of the data block for a CRC error. This option displays the contents of any error sector found, along with an error message.

3. Option #3 allows the operator to select a one or a two byte character for comparison for the test. It will display the following prompt:

Patterns can be specified by entering:

*1 for 256 byte pattern (hex 00 FF)
One or Two byte pattern - enter pattern in binary, octal, decimal or hex.

Select pattern:

You should select the same read bytes that you used to perform a write test (HARDS5 test #3). This option uses the CPU to compare the contents of the data block against the operator-selected pattern.

A compare error generates an error message along with the contents of the bad sector. Since the data block does have a CRC area associated with it, the sector CRC is also checked. It is possible (but unlikely) that the data could be compared favorably, but the CRC bits be found in error. If this occurs, a CRC ERROR display message will display.

4. Option #4 also allows you to select read-bytes. This option displays both status and compare errors, as well as the contents of the sector found in error.

Set Flag Byte for a Specific Sector

This function may be done in one of two ways.

1. You can use error map data provided by Seagate.
2. You can select the cylinder, head, and sector to be flagged.

Type 6 [RETURN] to select this test. The program displays this warning:

*****THIS TEST WILL ERASE FILES ON THE HARD DISK*****

Do you want to continue? (y or n)

Press any key when ready to start this test.

The program then displays this option menu.

Hard Disk "Flag Bad Sector" Options are:

1. **Disk Error Map**
2. **Cylinder, Head, Sector**

Make your selection and depress [RETURN]. If you select Option #1, you will be prompted to enter TRK, HD, byte count and length in bits. Type your selection and depress [RETURN].

```

Select option by number:      1
Enter CYL:                    60
Enter HD:                     2
Enter sector number:         4
Enter byte number:           300
Bad sector range:            cylinder = 60 head = 2 sector(s) = 12
    
```

Do you want to continue this test? Y/N

If you type Y at the prompt, the program will continue to prompt you for the next bad sector to be flagged, until all bad sectors have been flagged. If you enter N [RETURN] the program will return you to the hard disk menu.

NOTE

This function sets flags for bad sectors but it does not allocate alternate sectors to those sectors which you have flagged.

Hard Disk Read/Write Error Test

In this test, an error is considered to be a "soft" error when one unsuccessful attempt has been made to read data. A RECAL is made between each attempt. If the READ is successful on the second or third attempt, then the program declares a soft error. The program tolerates a certain number of soft errors.

The program declares a "hard" error after it has made three unsuccessful attempt to read data. The hard error is declared, flagged, and allocated. Sectors containing hard errors should be mapped by using either this test; test #7; or by using the combination of tests #6 and #8.

This test provides two functions:

1. It fully tests all aspects of the disk by writing and reading a variety of data patterns to the entire disk. The display will show all hard errors (bad sectors) and CRC errors.
2. Once the first function is terminated, the user is given the opportunity to allocate dummy files to those bad sectors which were flagged during the first portion of the test.

Press ESC to terminate the test. The program will go back and erase the entire disk and automatically flag those sectors which is identified as being bad.

*****THIS TEST WILL ERASE FILES ON THE HARD DISK*****

Do you want to continue? (y or n)

This Error Test MENU displays next.

Hard Disk "reliability" display Options:

1. Continuous display on terminal
2. Display error summary at the end of each pass
3. Display error summary only at the end of the test

Select option by number:

Use Option #1 with the ADM31 and Televideo 912 terminals, and other terminals with similar type cursor control.

Use Option #2 with any terminal.

Use Option #3 when no terminal is attached to the computer system or when the terminal is to be removed during test.

This prompt displays after you have selected your option.

Do you want to display data if a CRC error? (y or n)

Do you want to write specific patterns? (y or n)

A Y response to the last prompt will generate this pattern prompting menu. Type the pattern you want to write onto the disk and depress RETURN. The program will shift to the next pattern on the menu. Press RETURN alone to accept the pattern showing for the pattern option.

The screen will fill with the display which is used for this test. You will also hear the hard disk chirp as the heads seek the patterns on the disk.

Pattern #1 revisited: E5E5H
Pattern #2 revisited: 5555H
Pattern #3 revisited: AAAAH
Pattern #4 revisited: FFFFH

Press any key when ready to continue this test.

The program displays all patterns, and separates hard errors and soft errors into individual categories. If you have bad sectors on your hard disk you will be able to see the computer record the bad sectors as it encounters them. The counter also increments as it writes from track to track.

This test can take several hours to complete. Set up the test to run overnight, if possible. Press ESC to terminate the test. The test will complete its current pass, and stop. It will ask if you wish to print out the test results.

Pass count:
 Pattern:
 Cylinder:

Soft Errors

Chars: E5E5H	CMP Err 0	CRC Err 0	RNF Err 0	BAD SEC 0
Chars: 5555H	CMP Err 0	CRC Err 0	RNF Err 0	BAD SEC 0
Chars: AAAAH	CMP Err 0	CRC Err 0	RNF Err 0	BAD SEC 0
Chars: FFFFH	CMP Err 0	CRC Err 0	RNF Err 0	BAD SEC 0

Hard Errors

Chars: E5E5H	CMP Err 0	CRC Err 0	RNF Err 0	BAD SEC 0
Chars: 5555H	CMP Err 0	CRC Err 0	RNF Err 0	BAD SEC 0
Chars: AAAAH	CMP Err 0	CRC Err 0	RNF Err 0	BAD SEC 0
Chars: FFFFH	CMP Err 0	CRC Err 0	RNF Err 0	BAD SEC 0

Finishing Current Pass

Do you want to print (LP) the errors? YES=Y, NO=N

The program will display a soft error table that summarizes the entire test. Press any key on the keyboard to generate a hard error display.

Miscellaneous Functions

At present, this selection provides three unique functions:

1. You may alter the way displays are provided on other hard disk tests. Type 1 [RETURN] and the screen will display this prompt.

Do you want the disk error "status" message displayed? (y or n)

2. You may display a sector on the screen in ASCII, on the right side of the screen, and in HEX on the left side. Type 2 [RETURN] and the screen will display this menu.

* DISPLAY HARD DISK SECTOR *

Enter Cylinder Number:	(Select and Press RETURN)
Enter Head Number:	(Select and Press RETURN)
Enter Sector Number:	(Select and Press RETURN)

Type 4 [RETURN] to terminate this test. The display will return to the hard disk test menu.



DIGITAL RESEARCH™

Dear MP/M II User:

Digital Research® has developed the MP/M II™ operating system in response to numerous customer requests to add file sharing capability to MP/M™ V1.1. The design of MP/M II is a reflection of our goal to provide you with a state of the art operating system that can be configured for a wide variety of computer hardware.

This shipment contains the version 2.1 release of our MP/M II system. We have been pleased with the response to MP/M II V2.0 and hope to see comparable response to MP/M II V2.1 regarding design, possible extensions, and errors in implementation. We hope to maintain the same level of confidence that the computer industry has had in our CP/M® operating system.

On the basis of our experience and the experience of MP/M II users, we estimate that it requires less than a week to implement a simple polled MP/M II on a computer that has a running version of CP/M V2.2. Implementing a highly optimized MP/M II system with full interrupts and bank switched memory can require several weeks. Of course, the time to perform such a reconfiguration will vary widely depending on the experience of the programmer and the complexity of the hardware.

NOTE: Make sure that you use the SET or STAT command to make the USER.PRL file into a system file.

Contact the Digital Research Technical Support staff (408) 375-6262 if you experience difficulties reconfiguring MP/M II. By sending in your registration card you can insure that we will mail MP/M II application notes and patches that correct implementation errors.

Sincerely,

TECHNICAL SUPPORT

DIGITAL RESEARCH OPERATING SYSTEM END USER LICENSE AGREEMENT

Use and possession of this software package is governed by the following terms:

1. DEFINITIONS — These definitions shall govern:

- A. "DRI" means DIGITAL RESEARCH INC., P.O. Box 579, Pacific Grove, California 93950, the author and owner of the copyright on this computer program.
- B. "CUSTOMER" means the individual purchaser and the company CUSTOMER works for, if the company paid for this software.
- C. "COMPUTER" is the single computer on which you use this program. Multiple CPU systems may require supplementary licenses.
- D. "SOFTWARE" is the set of computer programs in this package, regardless of the form in which CUSTOMER may subsequently use it, and regardless of any modification which CUSTOMER may make to it.
- E. "LICENSE" means this Agreement and the rights and obligations which it creates under the United States Copyright Law and California laws.

2. LICENSE

DRI grants CUSTOMER the right to use this serialized copy of the SOFTWARE on a single COMPUTER at a single location so long as CUSTOMER complies with the terms of the LICENSE, and either destroys or returns the SOFTWARE when CUSTOMER no longer has this right. DRI shall have the right to terminate this license if CUSTOMER violates any of its provisions. CUSTOMER owns the diskette(s) purchased, but under the Copyright Law DRI continues to own the SOFTWARE recorded on it. CUSTOMER agrees to make no more than five (5) copies of the SOFTWARE for backup purposes and to place a label on the outside of each backup diskette showing the serial number, program name, version number and the DRI copyright and trademark notices in the same form as the original copy. CUSTOMER agrees to pay for licenses for additional user copies of the SOFTWARE if CUSTOMER intends to or does use it on more than one COMPUTER. If the computer on which CUSTOMER uses the SOFTWARE is a multi-user system, then the license covers all users on that single system, without further license payments, if the software was registered for that computer.

3. TRANSFER OR REPRODUCTION

CUSTOMER understands that unauthorized reproduction of copies of the SOFTWARE and/or unauthorized transfer of any copy may be a serious crime, as well as subjecting CUSTOMER to damages and attorney fees. CUSTOMER may not transfer any copy of the SOFTWARE to another person unless CUSTOMER transfers all copies, including the original, and advises DRI of the name and address of that person, who must sign a copy of the registration card, pay the then current transfer fee, and agree to the terms of this LICENSE in order to use the SOFTWARE. DRI will provide additional copies of the card and LICENSE upon request. DRI has the right to terminate the LICENSE, to trace serial numbers, and to take legal action if these conditions are violated.

4. ADAPTATIONS AND MODIFICATIONS

CUSTOMER owns any adaptations or modifications which CUSTOMER may make to this SOFTWARE, but in the event the LICENSE is terminated CUSTOMER may not use any part of the SOFTWARE provided by DRI even if CUSTOMER has modified it. CUSTOMER agrees to take reasonable steps to protect our SOFTWARE from theft or use contrary to this LICENSE.

5. LIMITED WARRANTY

The only warranty DRI makes is that the diskette(s) on which the SOFTWARE is recorded will be replaced without charge, if DRI in good faith determines that it was defective and not subject to misuse, and if returned to DRI or the dealer from whom it was purchased, with a copy of your registration card, within ten days of purchase. DRI will do its best to notify CUSTOMER of any significant corrections or errors in the SOFTWARE which DRI discovers for one (1) year after CUSTOMER purchase, IF CUSTOMER HAS SENT IN THE REGISTRATION CARD. DRI reserves the right to change the specifications and operating characteristics of the SOFTWARE it produces, over a period of time.

6. DRI MAKES NO OTHER WARRANTIES, EITHER EXPRESSED OR IMPLIED, AND DRI SHALL NOT BE LIABLE FOR WARRANTIES OF FITNESS OF PURPOSE OR MERCHANTABILITY, NOR FOR INDIRECT, SPECIAL OR CONSEQUENTIAL DAMAGES SUCH AS LOSS OF PROFITS OR INABILITY TO USE THE SOFTWARE. SOME STATES MAY NOT ALLOW THIS DISCLAIMER SO THIS LANGUAGE MAY NOT APPLY TO CUSTOMER. IN SUCH CASE, OUR LIABILITY SHALL BE LIMITED TO REFUND OF THE DRI LIST PRICE. CUSTOMER MAY HAVE OTHER RIGHTS WHICH VARY FROM STATE TO STATE. CUSTOMER and DRI agree that this product is not intended as "Consumer Goods" under state or federal warranty laws.

7. MISCELLANEOUS

This is the only agreement between CUSTOMER and DRI and it cannot and shall not be modified by purchase orders, advertising or other representations of anyone, unless a written amendment has been signed by one of our company officers. When CUSTOMER opens the SOFTWARE package or uses the SOFTWARE, this act shall be considered as mutual agreement to the terms of this LICENSE. This LICENSE shall be governed by California law, except as to copyright matters which are covered by Federal laws, and is deemed entered into at Pacific Grove, CA. by both parties.

NOTICE TO USER—PLEASE READ THIS NOTICE CAREFULLY—NOW!!! DO NOT OPEN THIS PACKAGE UNTIL YOU HAVE READ THE LICENSING AGREEMENT.

Our software License Agreement is displayed on this package, so you can read it before opening it. If you open the package and use the materials, DIGITAL RESEARCH will assume you have agreed to be bound by this standard agreement. If you do NOT accept the terms of this License, you must return the package UNOPENED to the Seller from whom you purchased it, who will refund your money. When you open the package, you need to sign and return the Registration Card in order to become a registered user, and thereafter to receive a number of substantial benefits, including support and notice of updated materials. DIGITAL RESEARCH does not support unregistered users.



**DIGITAL
RESEARCH™**

by

Gary C. Kilduff

President

SAVE THIS LICENSE FOR FUTURE REFERENCE



Preliminary Series 5 Computer System Supplement 4. Installing The MP/M II Operating System

Revision C.1
February 26, 1982

Disclaimer

This is a preliminary publication of the ALTOS Series-5 Computer System Documentation and is presented for information purposes only; it will be changed without notice.

The information contained herein represents the most current information available at the time of printing, however, the information has not been thoroughly reviewed nor has it been approved in its present form. ALTOS Computer Systems assumes no liability whatever related to use of information presented in this publication.

NOTE

This revision replaces but does not
obsolete previous revisions
of this document.

TABLE OF CONTENTS

GENERAL INFORMATION	S4-1
DIGITAL RESEARCH MANUALS	S4-1
KNOWN SYSTEM DEFICIENCIES	S4-1
MP/M II OPERATING SYSTEM FEATURES	S4-2
DISKETTE INSERTION AND WRITE PROTECTION	S4-3
Diskette Insertion	S4-3
Diskette Write Protection	S4-3
SYSTEM LOADING AND BACK-UP PROCEDURES.....	S4-3
BACKUP PROCEDURES 1 (FOR SERIES 5-5D SYSTEMS WITH HARD DISK DRIVES).....	S4-4
BACK-UP PROCEDURE 2 (FOR SERIES 5-15D SYSTEMS WITH TWO FLOPPY DISK DRIVES).....	S4-8
MANAGING FILES WITH THE PIP UTILITY PROGRAM	S4-10
MODIFYING YOUR SYSTEM WITH GENSYS	S4-10
Changing Your System to One or Two Users	S4-10
VIRTUAL DISK	S4-11
GENSYS for a One or Two Bank System	S4-11
MPMSETUP	S4-14
MPMSETUP FUNCTIONS	S4-14
Figure 1. Sample GENSYS Run	S4-12
Table 1. Sample MP/M II Disk Directory	S4-16

ALTOS SERIES 5 COMPUTER SYSTEM**SUPPLEMENT 4. INSTALLING THE MP/M II OPERATING SYSTEM****GENERAL INFORMATION**

This supplement provides all the information necessary for you to install the MP/M II operating system after the diagnostics have been successfully executed. It describes the MP/M II Operating System set-up and loading instructions and some system features. It explains how to use the PIP command to make a backup copy of the MP/M II diskette.

It also introduces you to related MP/M II technical manuals that came with your system diskette. These manuals were prepared by Digital Research Corporation. You should familiarize yourself with them before installing the operating system and refer to them, as required, during the installation process for further information regarding the MP/M II operating system.

DIGITAL RESEARCH MANUALS**MP/M II USER'S GUIDE**

Information on using the MP/M II operating system and running application programs on it. General information about MP/M II, its structure, messages, commands, and facilities.

MP/M II SYSTEM GUIDE

System internal organization and how to customize MP/M II.

MP/M II PROGRAMMER'S GUIDE

Programming interface to MP/M II, the system modules, utilities.

KNOWN SYSTEM DEFICIENCIES

At the time this preliminary document was printed, the following system deficiencies were known:

1. MPMSETUP must be run from the ADX diskette. It cannot be run from the MP/M II system.

2. Sometimes the self-test will run spontaneously when the system is booted after running MP/M II.
3. FTP, the File Transfer Program, can only transfer 15 files at a time under MP/M II 2.1. If you wish to exceed this limit, either use CP/M or multiple calls to FTP under MP/M II.

MP/M II OPERATING SYSTEM FEATURES

MP/M II is group of control programs that coordinate the activity of the computer system. They control memory utilization, manage files, access hardware devices, and perform other housekeeping chores. Some of these capabilities can be called and run from the console and some are used by the applications programs.

The manual "MP/M II USER'S GUIDE" describes MP/M II capabilities. This manual will help you in doing the operations covered in this section, and should be consulted.

Section 2 of the USER'S GUIDE lists all utilities provided with MP/M II by Digital Research. Altos provides other programs, some on the MP/M II system diskette and some on the ADX (diagnostic) diskette.

Here are some of the utilities provided by Altos.

Filename	Command	Command definition
COPY.COM	COPY	Copies entire diskette.
MFORMAT.COM	MFORMAT	Formats diskette.
BOOTCOPY.COM	BOOTCOPY	Transfers boot-track information (first two tracks) from diskette to diskette.
MPMSETUP.DIA	MPMSETUP	Updates the MP/M II boot sector on a diskette containing operating system files. The boot sectors contain relevant information such as baud rates. This information is used by the operating system to initialize itself.
		Note: MPMSETUP can only be run from the ADX diskette.
DISKSTAT.PRL	DISKSTAT	Allows you to obtain information on floppy and hard disk I/O errors. The user should use this command whenever I/O errors are suspected.

This file also displays the device name and physical attributes.

A temporary error is an I/O error that is successfully completed during a retry. If, after nine retries, the error still exists, a permanent error is declared.

The error counts are cumulative from power on until the system reset button is pushed or power is turned off. Each time the system is powered on, the error counts are set to 0, and will increment any time an I/O error occurs.

COPY, BOOTCOPY, and MFORMAT are provided on the ADX diskette and are run from that diskette. DISKSTAT is provided on the MP/M II system diskette. MPMSETUP may be on the MP/M II diskette; it must be copied to the ADX diskette and run from there.

DISKETTE INSERTION AND WRITE PROTECTION

The following information will be useful for doing the procedures in the rest of this section.

Diskette Insertion

To insert a 5 1/4" floppy diskette in a drive, open the door latch and insert the diskette with the manufacturer's label up. Seat it gently and close the door. (Note: inserting it upside down does no harm; it just won't work.)

Diskette Write Protection

5 1/4" floppy diskettes have a "write-enable" notch cut into the side of the jacket, near the label area.

NOTE

If the notch is open, data can be written on the diskette.

The diskette can be protected against being written on. The diskette manufacturer provides a special tape which is used to cover the notch.

NOTE

Before doing the procedures in the rest of this section, protect your master MP/M II diskette by covering the write notch with tape on both sides.

SYSTEM LOADING AND BACK-UP PROCEDURES

The MP/M II system diskette is ready to run. However, before you begin working with your MP/M II system, Altos recommends that you make a back-up copy of the MP/M II diskette for safekeeping, and then store that diskette in a safe place as a back-up for your system.

This section describes two procedures for making a back-up copy of your MP/M II system diskette. If your system has a hard disk, use the first procedure below; if it has two floppy disk drives, use the second procedure which starts on page 4-8 of this section.

When you have backed-up the MP/M II system diskette, use a copy to explore the system capabilities. It is configured for a three-user system, but will run on a one- or two-console system.

The GENSYS utility program, described later in this document, explains how to modify your system for one or two users. If you need to do this, it is not necessary to do it immediately. You can work with the system as is until you feel comfortable with it.

To start up MP/M II, power up your system and insert the system diskette in the right-hand drive, label up, and press the Reset button on the upper right. The MP/M II message will display on the console.

If you have a hard disk system, it will attempt to boot from the hard disk. Because the diagnostic procedures have initialized the hard disk it cannot boot. It will ask you where to boot from. Specify the floppy disk drive. When the system has booted, you will receive the MP/M II prompt. This is a number, letter, and ">"; for example:

0A>

Whenever the back-up procedures call for you to bring up the MP/M II system, use the procedure just described.

BACKUP PROCEDURE 1 (FOR SERIES 5-5D SYSTEMS WITH HARD DISK DRIVES)

This procedure leads you through the following operations:

If necessary, initializing the hard disk.

If necessary, formatting one or two blank, unformatted diskettes.

Using the BOOTCOPY program to place the boot system tracks on the blank diskettes.

Copying MP/M II from the master diskette onto the hard disk.

Copying MP/M II from the hard disk onto one or two blank diskettes.

The newly copied diskettes become your working copies. Store the original master diskette in a safe place.

What you need:

1. One or two blank diskettes, which will become the MP/M II working copy or copies. These diskettes must be write-enabled.
2. The ADX master diskette, or a working copy of it. If you are using the master diskette, write-protect it by covering the write notch with tape on both sides.
3. The MP/M II master diskette. This diskette must be write-protected. Cover the write notch with tape on both sides.
4. The Digital Research reference manuals for MP/M II, particularly MP/M II USER'S GUIDE.

Procedure steps:

1. The diagnostic procedures in Section 3 initialize the hard disk. If these procedures have not yet been done, do them.

If it is necessary for some reason to re-initialize the hard disk after the diagnostics have been run, use the HRDINIT5 program on the ADX diskette to do so. Section 3 explains how to do this. (Note: When the hard disk is initialized, any old data on it is lost.)

2. Copy the master MP/M II diskette material to the hard disk. Insert the MP/M II diskette into logical drive A. (If your system has two floppy disk drives as well as a hard disk, the right-hand drive is drive A.) Press the reset button to boot MP/M II.

The console will display the ALTOS identification message and the message "Press any key to interrupt Boot operation". Press a key, such as the space bar. The console will respond with a choice to boot from the hard disk or a floppy disk.

Note: You have about two seconds after the message to press a key. If you are not in time, you can press the Reset button again for a new try.

Enter a 2 in order to boot from the floppy disk.

Information will display on the console screen, followed by the MP/M II prompt of a number, a letter, and ">", for example:

ØA>

Use the PIP operating system command to move all the operating system programs from the source disk to the hard disk. After ØA> enter

PIP B:=A:*. *[V]

and press the RETURN key.

3. If your blank diskettes are not formatted, use the MFORMAT program to format a blank diskette. This program is on the ADX diskette. Insert that diskette in the drive and press the Reset button to bring it up. After the REQUEST message, enter MFORMAT and press the RETURN key.
 - a. This program will prompt you to exchange the ADX diskette (the source diskette) for a blank, unformatted diskette (the object diskette). It displays the MFORMAT menu and prompts you to enter a menu option number and press the RETURN key. It returns you to the MFORMAT menu when it completes the formatting operation.
 - b. Remove the newly formatted diskette from logical drive A. If you wish to format another diskette, replace it with another and repeat the operation.
 - c. Set your newly formatted diskette(s) aside.
 - d. When you have finished, leave the ADX diskette in the drive for the next operation.
4. Use the BOOTCOPY program to copy the first two boot tracks of the source diskette onto the blank, newly formatted diskettes. BOOTCOPY is available on the ADX diskette. If it is not in the drive (from step 4), insert it and press the Reset button to bring it up. After the REQUEST message, enter BOOTCOPY and press the RETURN key.
 - a. The program will prompt you to insert the source diskette into logical drive A, and press the RETURN key. Place the MP/M II master diskette in logical drive A, the right-hand drive, as the source diskette.
 - b. The program then prompts you to remove the source diskette and insert the object diskette (one of the formatted diskettes) into logical drive A, and press the RETURN key.
 - c. Repeat for a second formatted blank diskette, if desired.

5. Use the PIP command to copy the MP/M II system files from the hard disk to the formatted blank diskette. Return to the MP/M II system by inserting the MP/M II diskette in logical drive A and pressing the Reset button.

- a. The hard disk has a copy of the MP/M II system. (The information was transferred in step 2.) Transfer system control to the hard disk by entering

B:

and pressing the return key.

- b. Remove the MP/M II master diskette and insert one of the blank, formatted, boot-copied diskettes into logical drive A. Copy the contents of the hard disk onto the blank disk in drive A by entering

PIP A:=B:*. *[V]

and pressing the RETURN key.

When the operation completes, store your MP/M II master diskette in a safe place. Use the newly copied MP/M II diskette for all further operations.

- c. If desired you can repeat this operation with a second diskette which has been formatted and given a boot track.

At the end of this procedure you should have copied your MP/M II master diskette onto a newly formatted diskette and stored the master diskette in a safe place. Label the newly copied diskette(s) for identification. Write-protect the diskettes by placing tape over both sides of the write notch.

NOTE

You now have MP/M II functions available on the hard disk. After you have booted up from a floppy disk in logical drive A, you can switch to the hard disk drive (drive B) and run from it. To do so, after the prompt `ØA>`, enter

B:

and press the RETURN key.

The MPMSET utility program, described later, allows you to modify your system to boot from the hard disk without using a floppy diskette.

BACKUP PROCEDURE 2 (FOR SERIES 5-15D SYSTEMS WITH TWO FLOPPY DISK DRIVES)

This procedure leads you through the following operations:

If necessary, formatting one or two blank diskettes.

Using the COPY utility to make a backup copy or copies of the MP/M II master diskette.

What you need:

1. One or two blank diskettes, which will become the MP/M II working copy or copies. These diskettes must be write-enabled.
2. The MP/M II master diskette. This diskette must be write-protected. Cover the write notch with tape on both sides.
3. The Digital Research reference manuals for MP/M II, particularly MP/M II USER'S GUIDE.

When making a backup copy of the system disk, proceed as follows.

1. If necessary, use the MFORMAT program to format one or two blank diskettes. This program is on the ADX diskette.
 - a. Turn on the system, insert the ADX master diskette into logical drive A (the right-hand drive), and press the RESET button.
 - b. Insert a blank, unformatted diskette into logical drive B (the left-hand drive).
 - c. After the REQUEST prompt, enter MFORMAT, and press the RETURN key.
 - d. This program will prompt you to specify the drive assignments for the ADX diskette (the source diskette), and for the blank, unformatted diskette (the object diskette). It returns you to the MFORMAT Menu when the format operation is complete.
 - e. You may place another diskette in drive B and format it, if desired.
 - f. When you have finished formatting diskettes, exit from MFORMAT to the ADX menu. Leave the ADX diskette in the drive for the next step.
2. Use the COPY utility to make a backup copy of the master diskette. This program is on the ADX diskette. If ADX is not in control (from step 1), insert the ADX diskette in

logical drive A (the right-hand drive), and press the Reset button.

- a. Insert a newly formatted blank diskette into drive B.
- b. After the REQUEST prompt, enter COPY and press the RETURN key.
- c. The program will prompt you to specify the drive assignments for the source diskette, and for the blank, formatted diskette. Place the MP/M II diskette in drive A as the source. Drive B is the destination.
- d. The program returns you to the ADX menu when complete.
- e. You can repeat this procedure to make another copy.

At the end of this procedure, you should store the MP/M II master diskette in a safe place. Label the newly copied diskettes with the identification information. From now on, use a copied diskette to run MP/M II. Write-protect each diskette by placing tape over both sides of the write notch.

If you wish to bring up the MP/M II system now, insert a new MP/M II diskette into logical drive A and press the Reset button.

MANAGING FILES WITH THE PIP UTILITY PROGRAM

THE PIP utility program transfers files between any two peripheral components in your computer system. Use PIP to copy, transfer, break, or join files on a diskette or hard disk. PIP can copy files from one user to another. PIP can list a text file on the printer.

Using PIP, you can compose elements of a software program, edit text, move one or more files from one storage device to another, or use one file to control a system device, or to modify another file. You probably will use PIP more than any other transient file listed on your operating system directory.

For a complete explanation of the PIP utility, see the manual entitled MP/M II USER'S GUIDE that came with your operating system.

MODIFYING YOUR SYSTEM WITH GENSY

The GENSY program is described in section 5 of MP/M II SYSTEM GUIDE. Section 1 of the USER'S GUIDE gives some background information. If you wish to modify your system, read this information carefully.

Changing Your System To One Or Two Users

Altos furnishes your system set up for three users. Changing it for fewer users is fairly simple; however, you should read the SYSTEM GUIDE carefully before you do it.

For your convenience, here is a short explanation of how to change the system for one user or two users. This is supplementary information and does not replace the information in the SYSTEM GUIDE.

1. Bring up MP/M II and run GENSYS.
2. Only two items need to be changed. All other questions can be answered by pressing the RETURN key to confirm the default value shown.
3. The two entries that need to be changed are:
 - a. "Number of TMPs (system consoles) (#3)?"
 - b. "Number of User Memory Segments (#3)?"

If you wish to specify a two-user system, reply #2 to both of these.

If you wish to specify a one-user system, reply #1 to both of these.

Figure 1, following, shows a sample run of GENSYS to change the system to a one-user system. It is a sample only, and some of the details and defaults may be different on your system.

VIRTUAL DISK

One reason to change your system to have fewer users is that MP/M II can make available a "virtual disk," called disk E. This is a memory device of up to 96 kilobytes of storage capacity. If you use fewer than 3 banks of memory in your system, the remaining bank(s) will be available for a virtual disk. The virtual disk has a capacity of 48K bytes for each bank not used by MP/M II. (If you have 3 banks in use, the virtual disk will have zero bytes of storage.)

This "disk" can be used like a real disk of the same capacity with one important exception. When you turn the power off, or power goes off unexpectedly, the contents of the "disk" are erased. A good use for the virtual disk is temporary storage for work files in your program. These files would not normally be saved so the power-off problem will not be noticed. When you are working with important information in virtual disk files, you should transfer a copy to an actual disk from time to time for security.

The advantage of the virtual disk is that because all accesses to it are actually memory accesses, the "disk" is very fast.

NOTE

By using the MPMSETUP utility, described later in this section, you can change the name as disk E. For example, you could make it disk M, for Memory.

GENSYS for a One or Two Bank System

Figure 1, following, shows a sample run of GENSYS. <CR> stands for a carriage return entered by the user. The default options (shown inside parentheses) were entered by pressing the RETURN key. Only two items were changed.

* * * * *

Note: Resident Disk Processors

This note applies only for those doing advanced system configuration. When including Resident System Processors, bank 0 cannot go below 4000H in size. You may wish to write this note at section 4.5 of the MP/M II SYSTEM GUIDE.

```
0A>GENSYS
00:00:16 A:GENSYS .COM
```

MP/M II V2.1 System Generation
 Copyright (C) 1981, Digital Research

Default entries are shown in (parens).
 Default base is Hex, precede entry with # for decimal

```
Use SYSTEM.DAT for defaults (Y) ? <CR>
Top page of operating system (FF) ? <CR>
Number of TMPs (system consoles) (#3) #1 <CR> **
Number of Printers (#2) ? <CR>
Breakpoint RST (07) ? <CR>
Enable compatibility attributes (Y) ? <CR>
Add system call to user stacks (Y) ? <CR>
Z80 CPU (Y) ? <CR>
Number of ticks/second (#60) ? <CR>
System Drive (A:) ? <CR>
Temporary file drive (A:) ? <CR>
Maximum locked records/process (#16) ? <CR>
Total locked records/system (#32) ? <CR>
Maximum open files/process (#16) ? <CR>
Total open files/system (#32) ? <CR>
Bank switched memory (Y) ? <CR>
Number of user memory segments (#3) ? #1 <CR> **
Common memory base page (C0) ? <CR>
Dayfile logging at console (Y) ? <CR>
```

```
SYSTEM DAT FF00H 0100H
TMPD    DAT FE00H 0100H
USERSYS STK FD00H 0100H
XIOSJMP TBL FC00H 0100H
```

Accept new system data page entries (Y) ? <CR>

```
RESBDOS SPR F000H 0C00H
XDOS    SPR CE00H 2200H
```

Select Resident and Banked System Processes:

```
ABORT   RSP (N) ? <CR>
MPMSTAT RSP (N) ? <CR>
SCHED   RSP (N) ? <CR>
SPOOL   RSP (N) ? <CR>
```

```
BNKXIOS SPR AE00H 1F00H
BNKBDOS SPR 8B00H 2300H
BNKXDOS SPR 8900H 0200H
TMP      SPR 8500H 0400H
```

Figure 1 - Sample GENSYS Run
 (continues)

```
LCKLSTS DAT 7400H 0300H
CONSOLE DAT 7300H 0100H
```

Enter memory segment table:

```
Base,size,attrib,bank (87,79,80,00) ? <CR>
```

```
MP/M II Sys 8700H 7900H Bank 00
Memseg  Usr 0000H C000H Bank 01
```

Accept new memory segment table entries (Y) ? <CR>

```
** GENSYS DONE **
0A>
```

** Note: The only changes from the original system are to change from three system consoles to one and from three memory banks to one. These changes are flagged by ** at the right.

To change to a two-console, two-bank system, enter #2 in place of #1 at the two places flagged.

Figure 1 - Sample GENSYS Run
(finished)

MPMSETUP

The MPMSETUP program is not part of the ordinary installation procedures. It allows you to make certain system changes without running GENSYS, and certain changes that GENSYS cannot make. For example, it allows you to change console and printer baud rates, or to change the default names for the logical drives. You can designate Drive A to be on the hard disk instead of the floppy disk. You can change your system to boot from the hard disk without a floppy disk.

MPMSETUP cannot, at present, be run under MP/M II. It is run from the ADX disk. If it is not on the ADX disk, use the PIP utility to copy it to the ADX diskette from the MP/M II diskette. (If you have only one diskette drive, copy it to the hard disk or the virtual disk first and then to the ADX diskette.)

MPMSETUP FUNCTIONS

Before you run MPMSETUP, read the following information.

Note: The changes you make with MPMSETUP do not take effect unless you use the update function (menu selection 5). The changes will be in effect when you next boot your system. You can exit from MPMSETUP without updating, and your system will remain unchanged. This is convenient, in case you have made a mistake.

NOTE

When MPMSET is run from the ADX diskette, the references to disk drives are independent of the MP/M II assignments. The hard disk is simply referred to as the hard disk. the right-hand floppy drive is drive A; if there is a left-hand drive it is drive B. Please use these assignments when responding to MPMSET prompt messages.

Here are the menu choices:

- 1) Copy bootfile to hard disk
- 2) Change default logical names
- 3) Console baud rate setup
- 4) Printer setup
- 5) Update setup
- 6) Exit

1) Copy bootfile to hard disk: This function copies the boot records to the hard disk, so that system boot can be performed from the hard disk.

As furnished, your system will attempt to boot from the hard disk and if it cannot, will ask you where to boot from. Using the "Copy bootfile to hard disk" function allows you to start and run

your system without any diskette in the floppy drive. If you want to be able to run your system without having a floppy diskette in the drive, copy the bootfile and then use function 2, "Change default logical names," to specify the hard disk as logical drive A.

2)Change default logical names: This function allows you to choose the names for the various logical hard disk devices, floppy drives and virtual disk. Only one name per device is allowed and one of the names must be 'A'.

3)Console baud rate setup: This function is used to set up the baud rates for the various consoles. If you are making a series of changes, you may wish to update after each good change. You can use BOOTCOPY to copy system changes to other diskettes.

4)Printer setup: Series 5 MP/M II supports two printers, one serial and one parallel (Centronics or Centronics-type). The printers are numbered 0 and 1, and this function allows you to specify which printer has precedence (low number). You specify the Centronics type printer as 0 or 1, and the serial printer then becomes 1 or 0. You can also specify the baud rate for the serial printer. The default is 9600 baud.

	<u>Printer Number</u>	
Centronics Parallel	0	1
Serial Printer	1	0

5)Update setup: This function actually does the updating of the boot sectors. This function should be selected only after making sure that all the settings you have chosen are what you want. The program can always be aborted by choosing function 6. If you are making a series of changes, you may wish to update after each good change.

When updating boot information on a floppy diskette, be sure that you update the MP/M II system diskette and not the ADX diskette. Remove the ADX diskette, if necessary. It is only used to invoke MEMSETUP. After you have updated a system diskette, you can use BOOTCOPY to copy system changes to other diskettes.

6)Exit: This function causes you to exit from the MPMSETUP program. If you exit without using function 5, no changes will actually be made.

NOTE

A sample directory is presented on the following page. The directory of your MP/M II system disk may look somewhat different from the sample.

Table 1. Sample MP/M II Disk Directory

SDIR
00:00:40 A:SDIR .PRL

Directory For Drive A: User 0

Name	Bytes	Recs	Attributes	Name	Bytes	Recs	Attributes
ABORT	PRL	4k	5 Dir RW	ABORT	RSP	4k	5 Dir RW
ASM	PRL	12k	74 Dir RW	BNKBDOS	SPR	12k	81 Dir RW
BNKXDOS	SPR	4k	7 Dir RW	BNKXIOS	SPR	8k	60 Dir RW
BOOT	ASM	4k	15 Dir RW	BUTTONS	LIB	4k	4 Dir RW
COMPARE	LIB	4k	9 Dir RW	CONSOLE	PRL	4k	4 Dir RW
DDT	COM	8k	42 Dir RW	DEBLOCK	ASM	12k	80 Dir RW
DIR	PRL	4k	14 Dir RW	DISK	DOC	4k	10 Dir RW
DISKDEF	LIB	8k	51 Dir RW	DISKSTAT	PRL	4k	14 Dir RW
DOWHILE	LIB	4k	7 Dir RW	DSKRESET	PRL	4k	5 Dir RW
DSTACK	LIB	12k	80 Dir RW	DUMP	ASM	8k	36 Dir RW
DUMP	PRL	4k	6 Dir RW	ED	PRL	12k	68 Dir RW
ERA	PRL	4k	15 Dir RW	ERAQ	PRL	4k	29 Dir RW
EXTRN	ASM	4k	2 Dir RW	GENHEX	COM	4k	6 Dir RW
GENMOD	COM	4k	10 Dir RW	GENSYS	COM	12k	74 Dir RW
IS085	LIB	4k	3 Dir RW	INTER	LIB	4k	17 Dir RW
LDRBIOS	ASM	8k	64 Dir RW	LIB	COM	8k	56 Dir RW
LINK	COM	16k	122 Dir RW	LOAD	COM	4k	14 Dir RW
MPM	SYS	32k	234 Dir RW	MPMLDR	COM	8k	45 Dir RW
MPMSETUP	DIA	20k	160 Dir RW	MPMSTAT	BRS	8k	33 Dir RW
MPMSTAT	PRL	8k	33 Dir RW	MPMSTAT	RSP	4k	3 Dir RW
NCOMPARE	LIB	4k	10 Dir RW	PIP	PRL	12k	77 Dir RW
PRINTER	PRL	4k	8 Dir RW	PRLCOM	PRL	4k	21 Dir RW
RDT	PRL	8k	50 Dir RW	REN	PRL	4k	19 Dir RW
RESBDOS	SPR	4k	29 Dir RW	RESXIOS	ASM	20k	154 Dir RW
RMAC	COM	16k	106 Dir RW	SCHED	BRS	4k	12 Dir RW
SCHED	PRL	4k	20 Dir RW	SCHED	RSP	4k	3 Dir RW
SDIR	PRL	20k	137 Dir RW	SELECT	LIB	4k	13 Dir RW
SEQIO	LIB	12k	82 Dir RW	SET	PRL	8k	60 Dir RW
SHOW	PRL	8k	60 Dir RW	SIMPJO	LIB	4k	5 Dir RW
SPOOL	BRS	4k	20 Dir RW	SPOOL	PRL	4k	17 Dir RW
SPOOL	RSP	4k	5 Dir RW	STACK	LIB	4k	9 Dir RW
STAT	PRL	12k	73 Dir RW	STOPSPLR	PRL	4k	5 Dir RW
SUBMIT	PRL	8k	42 Dir RW	SYSTEM	DAT	4k	2 Dir RW
TMP	SPR	4k	11 Dir RW	TOD	PRL	4k	20 Dir RW
TODCNV	ASM	16k	126 Dir RW	TREADLES	LIB	4k	5 Dir RW
TYPE	PRL	4k	11 Dir RW	USER	PRL	4k	8 Dir RW
WHEN	LIB	4k	7 Dir RW	XDOS	SPR	12k	79 Dir RW
XREF	COM	16k	121 Dir RW	Z80	DOC	12k	70 Dir RW
Z80	LIB	8k	47 Dir RW				

Total Bytes = 576k Total Records = 3146 Files Found = 77
 Total 1k Blocks = 430 Used/Max Dir Entries For Drive A: 77/ 177



Preliminary Series 5 User Manual

Revision D/February 26, 1982

DISCLAIMER

THIS IS A PRELIMINARY PUBLICATION OF THE ALTOS SERIES-5 COMPUTER SYSTEM DOCUMENTATION AND IS PRESENTED FOR INFORMATION PURPOSES ONLY; IT WILL BE CHANGED WITHOUT NOTICE.

THE INFORMATION CONTAINED HEREIN REPRESENTS THE MOST CURRENT INFORMATION AVAILABLE AT THE TIME OF PRINTING, HOWEVER, THE INFORMATION HAS NOT BEEN THOROUGHLY REVIEWED NOR HAS IT BEEN APPROVED IN ITS PRESENT FORM. ALTOS COMPUTER SYSTEMS ASSUMES NO LIABILITY WHATEVER RELATED TO USE OF INFORMATION PRESENTED IN THIS PUBLICATION.

FEDERAL COMMUNICATIONS COMMISSION NOTICE

W A R N I N G

This equipment generates, uses and can radiate radio frequency energy and, if not installed and used in accordance with the instructions manual, may cause interference to radio communications. It has been tested and found to comply with the limits for a Class A computing device pursuant to Subpart J of Part 15 of FCC Rules, which are designed to provide reasonable protection against such interference when operated in a commercial environment. Operation of this equipment in a residential area is likely to cause interference in which case the user, at his own expense, will be required to take whatever measures may be required to correct the interference.

ALTOS COMPUTER SYSTEMS

SERIES 5 USER MANUAL

REVISION D

FEBRUARY 26, 1982

DISCLAIMER

THIS IS A PRELIMINARY PUBLICATION OF THE ALTOS SERIES 5 COMPUTER SYSTEM DOCUMENTATION AND IS PRESENTED FOR INFORMATION PURPOSES ONLY; IT WILL BE CHANGED WITHOUT NOTICE.

THE INFORMATION CONTAINED HEREIN REPRESENTS THE MOST CURRENT INFORMATION AVAILABLE AT THE TIME OF PRINTING, HOWEVER, THE INFORMATION HAS NOT BEEN THOROUGHLY REVIEWED NOR HAS IT BEEN APPROVED IN ITS PRESENT FORM. ALTOS COMPUTER SYSTEMS ASSUMES NO LIABILITY WHATEVER RELATED TO USE OF INFORMATION PRESENTED IN THIS PUBLICATION.

ACS Manual Part Number: 690-11089

Copyright 1982

TABLE OF CONTENTS

SECTION 1. INTRODUCTION

GENERAL INFORMATION	1-1
Scope and Purpose of this Manual	1-1
How to Use this Manual	1-2
GENERAL SYSTEM DESCRIPTION	1-3
General Hardware Description	1-3
SYSTEM COMPONENTS	1-4
Table 1-1. Altos Series 5 Configuration Chart	1-5
CONVENTIONS USED IN THIS MANUAL	1-5
TERMS AND ABBREVIATIONS USED IN THIS MANUAL	1-6
RELATED PUBLICATIONS	1-6

SECTION 2. INSTALLING YOUR COMPUTER SYSTEM

GENERAL INFORMATION	2-1
PREPARING YOUR WORK STATION AREA	2-1
UNPACKING YOUR COMPUTER SYSTEM	2-2
SHIPPING CONTAINER CONTENTS LIST	2-2
ITEMS YOU MUST SUPPLY	2-3
SYSTEM CONFIGURATION	2-4
SETTING UP YOUR COMPUTER SYSTEM	2-4
TURNING ON YOUR SYSTEM	2-8

SECTION 3. EXECUTING DIAGNOSTIC PROGRAMS

GENERAL INFORMATION	3-1
---------------------------	-----

SECTION 4. OPERATING SYSTEMS

GENERAL INFORMATION	4-1
---------------------------	-----

SECTION 5. ALTOS UTILITY PROGRAMS

GENERAL INFORMATION	5-1
---------------------------	-----

SECTION 6. UPGRADE KITS AND ADD KITS

GENERAL INFORMATION	6-1
---------------------------	-----

SECTION 7. HARDWARE OPERATING SPECIFICATIONS

SUMMARY OF SPECIFICATIONS (Models 5-5D, and 5-15D)	7-1
Computer	7-1
Chip Set	7-1
I/O Ports	7-1
System Memory	7-1
Mass Storage	7-1
DETAILED COMPUTER SPECIFICATIONS	7-2
System Memory	7-2
Memory Mapping	7-2
Bank Selection	7-2
Write Protection	7-3
Parity	7-3
Boot PROM	7-3
Floppy Disk Controller	7-3
Hard Disk Controller	7-4
I/O Ports	7-4
Configuration Port	7-5
I/O Port Assignment	7-5
Bit Assignment for the I/O Port	7-7
Interrupt Priority Daisy Chain	7-8
Mass Storage Devices	7-9
Floppy Disk Drive Specification Summary Flexible Disk Drive (Control Data 9409T 5-1/4")	7-9
Performannce Specifications	7-9
Functional Specifications	7-9
Error Rates	7-10
Hard Disk Drive Specification Summary (Winchester Type Fixed Disk) Seagate Technology (ST506 Microwinchester)	7-10
Performannce Specifications	7-10
Functional Specifications	7-11
Error Rates	7-11
General Physical Specifications	7-11
Environmental Requirements	7-11
AC Power Requirements	7-11
Physical Dimensions	7-12
Weight	7-12
Jumpers on the CPU Board (11073)	7-12
System Configuration Jumpers	7-12
Debugging Aids Jumpers	7-12
Network Port Enabling Jumpers	7-12
RTS/CTS Loop Enabling Jumpers	7-13
Optional On-Board Baud Rate Generator Jumpers	7-13

APPENDICES

APPENDIX A. MATRIX MAPS A-1
APPENDIX B. SCHEMATICS B-1
APPENDIX C. SHIPPING DAMAGE AND SYSTEM REPAIR PROCEDURES ... C-1
APPENDIX D. INSTRUCTIONS FOR PINNING SERIES 5 PRINTED
CIRCUIT BOARDS D-1

ALTOS SERIES 5 COMPUTER SYSTEM**USER MANUAL****SECTION 1. INTRODUCTION****GENERAL INFORMATION****Scope and Purpose of this Manual**

This User Manual is divided into **seven sections** (described individually in the immediately following paragraphs), with appendices A through D, and an Index.

Section 1. INTRODUCTION introduces you to the Altos Series 5 Computer System, including its features, capabilities, configurations, component parts (both hardware and software), and related publications. It is general and descriptive, but neither instructive nor tutorial.

Section 2. INSTALLATION tells you how to remove the computer from the shipping container, identify the components and physically assemble the system, following the step-by-step instructions provided. This section instructs you in doing everything short of running the diagnostics.

Section 3. DIAGNOSTICS introduces you to SUPPLEMENT 3. EXECUTING DIAGNOSTIC PROGRAMS, which provides specific instructions for executing the individual diagnostic programs, verifying proper system operation and doing everything short of installing the operating system.

Section 4. OPERATING SYSTEMS introduces you to one or more of three supplements, each one of which provides information related to operating systems in general, and provides specific instructions for installing particular operating systems.

One or more of the operating system supplements will be provided with your system. You will get only the operating system supplement related to the Operating System(s) you buy (CP/M, MP/M II, or OASIS).

Each subsection contains all the information necessary for you to install the operating system(s) after the diagnostics have been successfully executed. The Operating System Subsection also introduces you to the supplementary manuals related to the subject operating system.

Section 5. ALTOS UTILITY PROGRAMS introduces you to SUPPLEMENT 5. ALTOS UTILITY PROGRAMS which contains specific descriptions of utility programs available at the time of printing. (Revision C contains only a description of the File Transfer Program (FTP).

Section 6. introduces you to SUPPLEMENT 6. UPGRADE KITS AND ADD KITS which provides specific instructions for increasing the capabilities of your Series 5 Computer System. When you purchase an Add Kit or an Upgrade Kit you will be provided with an Installation Procedure written specifically for that kit. After the installation is completed, that procedure should be inserted in your User Manual in this section.

Section 7. ALTOS SERIES 5 COMPUTER SYSTEM HARDWARE SPECIFICATIONS provides more specific details related to: system functions; hardware functions; physical, electrical, and environmental specifications; operating systems and programming languages.

APPENDIX A. MATRIX MAPS includes all matrix maps in the form current at the time the current revision of the manual is printed. (Early releases may not have this appendix.)

APPENDIX B. SCHEMATICS includes all schematic diagrams in the form current at the time the current revision of the manual is printed.

APPENDIX C. SHIPPING DAMAGE AND SYSTEM REPAIR PROCEDURES.

APPENDIX D. INSTRUCTIONS FOR PINNING SERIES 5 PRINTED CIRCUIT BOARDS.

INDEX (Early releases may not have this section.)

How to Use this Manual

This manual guides you through the complete installation process for your computer system from unpacking the shipping container through calling in and executing your application programs. Perform the following steps to set up your Series 5 Computer system.

1. Read Section 1 to become familiar with your system.
2. Refer to Section 2 and follow the instructions for unpacking your system and physically connecting the system components.
3. Refer to Section 3 and Supplement 3 and follow the instructions for configuring your system and executing the diagnostic programs that initialize the system and verify correct operation of the system components. This section also instructs you in making backup copies as required.
4. Run the diagnostic programs to verify that your system is operating properly.

5. Refer to Section 4 and the applicable Supplement 4 for information regarding the specific operating system you are using. This section tells you how to install that operating system and how to load and execute your application programs.
6. Refer to Section 5 and Supplement 5 for information regarding available Altos Utility Programs. Revision C describes only the File Transfer Program (FTP).
7. Refer to Section 6 and Supplement 6 for information regarding Upgrade Kits and Add Kits. At this time of this printing, no kits have yet been released.
8. Refer to Section 7 (which was Section 5 in the previous revision) and the appendices if more specific information is desired regarding operation of either the hardware or software.

The set up procedure and diagnostic programs are similar for all Series 5 computer models. They will vary, depending upon the configuration of your model and the peripherals included with your system. You will load and run only those diagnostics programs appropriate for your system. You will use one of three operating systems, CP/M, MP/M II or OASIS (described in Section 4). Each of these systems has its own loading procedures and operating characteristics.

GENERAL SYSTEM DESCRIPTION

General Hardware Description

Your Series 5 computer system is a Z80A-based multiuser system designed to fit many commercial, technical, industrial, scientific, and educational applications. It can run under either CP/M, MP/M II, or OASIS operating systems. In its basic configuration, the system is contained in a single chassis, however, additional chassis (Add Kits and Upgrade Kits) may be connected to the basic chassis to increase system capabilities.

The basic computer system includes the CPU, four RS-232-C ports, one parallel port, 192 kilobytes of RAM, all peripheral controllers, and one 5-1/4 inch floppy disk drive. You have to add a keyboard terminal, provide your own floppy diskettes and cabling. You may also want to add a printer.

The Series 5-5D also includes a five-megabyte, five-inch hard disk drive.

Series 5-15D also includes a second one-megabyte, unformatted, 5 1/4-inch floppy disk drive unit. (See Table 1-1 Series 5 Configuration Chart for further details.)

An extra hard disk drive may be added to the basic system. Up to three terminals, one serial printer and one parallel printer may also be connected to the system.

SYSTEM COMPONENTS

A complete ACS Series 5 system includes:

A Series 5 Computer (complete with power cord, fuse and fuse cap).

Model 5-5D, or 5-15D.

A user-supplied keyboard CRT terminal (minimum of one, maximum of 3).

Serial data transmission rate of 9600 baud is required for console number 1.

A user-supplied printer (dot matrix or impact quality print)

RS-232-C serial or Centronics parallel interface, one or two (one serial and one parallel interface) printers can be supported depending on the operating system used.

User-supplied Interface Cables for the Terminal and Printer

To maintain F.C.C. Class A compliance and limit possible radio/TV interference, all interface cables should have a grounded shield and be electrically and mechanically secured to the units they are connected to.

Altos Diagnostic Program Diskette and Operating Instructions

Provided with your system.

Operating System Software and Operating Instructions

At least one operating system (CP/M, MP/M II, or OASIS) is required.

NOTE

All operating systems are registered with the licensed seller and distributed under license to the end user to operate only on a single computer. If your operating system is CP/M, MP/M II, or OASIS it must be registered with Altos Computer Systems and the label on the diskette should identify it as being so with a version number and serial number. Do not accept any others.

Altos Series 5 User Manual

User Manual supplement applicable to your Operating System.

Table 1-1. Altos Series 5 Configuration Chart

Ser.5 Model No:	No: of Floppy Drives	No: of Hard Disk Drives	Max. No: of Users	No: of addit- ional hard drives sup- ported	Diagnostic Notes
5-5D	1	1	3	1*	Run both floppy and and Hard Disk diag- nostic tests.
5-15D	2	0	3	2**	Run floppy disk diag- nostics only

* Series 5-5D supports only the addition of one Add-5 Kit which adds 5 Mbytes of formatted hard disk storage; this Series 5-5 configuration is incompatible with an Add-10 Kit.

** Series 5-15D can support the addition of one UK-5 Upgrade Kit (which adds an additional 5 Mbytes of unformatted hard disk storage) and a later addition of an Add-5 Kit (which adds another 5 Mbytes of formatted hard disk storage for a total of 10 Mbytes).

CONVENTIONS USED IN THIS MANUAL

Altos Computer Systems manufactures two types of equipment, "A" after the model number designates 100/115 VAC, 60 Hz equipment, and "E" after the model number designates 200/230 VAC, 50 Hz equipment. This convention is generally reflected in the part numbering scheme wherein the final three digits "001" usually designate parts manufactured for use with the 100/115 VAC equipment and "002" usually designate parts used with 200/230 VAC equipment. For brevity, the final three digits of the part number have been omitted throughout this manual.

TERMS AND ABBREVIATIONS USED IN THIS MANUAL

For brevity, the following abbreviations have been used in this manual:

MTU -	Magnetic Tape Unit
MTC -	Magnetic Tape Controller (Board)
HDU -	Hard Disk Unit
HDC -	Hard Disk Controller (Board)
CPU -	Central Processing Unit
PCB -	Printed Circuit Board
MBYTE -	Megabyte (One million bytes of storage)
CONSOLE -	CRT terminal with keyboard (with RS-232-C interface)

RELATED PUBLICATIONS

The following publications are related to and used with this Series 5 Computer System User Manual.

(LIST TO BE PROVIDED)

SECTION 2. INSTALLING YOUR COMPUTER SYSTEM**GENERAL INFORMATION**

This section tells you how to; prepare a work station area, unpack the computer, identify the components and physically assemble the system by following the step-by-step instructions provided. This section instructs you in doing everything short of running the diagnostic programs.

You are guided through the following activities:

- a. Preparing a work station area for your computer system.
- b. Unpacking the computer and system components.
- c. Configuring your system to operate with the system components you have.
- d. Checking specifications for your system and hooking up data cables and power cords for system components.
- e. Turning on your computer system.

PREPARING YOUR WORK STATION AREA

Setting up your computer is a simple process. First, organize a comfortable, well-lighted work area. You must have power cords and data cables to connect every component in your computer system.

You must supply all CRT and printer interface cables your system will require. These cables are NOT supplied with your computer. You also will need at least four blank, unformatted diskettes not supplied with your system.

Carefully route all cords and cables away from traffic areas. All power cords may be plugged into a single power strip of adequate capacity, with minimal A.C. line noise interference. The line voltage requirements are 110 VAC (plus-or-minus 10%) or 220 VAC (plus-or-minus 10%) with a frequency range of 47 to 63 Hz.

ALTOS recommends you dedicate a separate power line to your Series 5 Computer System. Position your terminal away from windows to minimize screen glare. If static is a problem in your area you should minimize the risk of static damage by the use of anti-static mats and materials where appropriate; e.g. in front of each terminal and the computer.

Do not cover the air ventilation louvres on the computer.

UNPACKING YOUR COMPUTER SYSTEM

Remove the computer system from the shipping container as described below. Make note of the method used (if you have already opened the container, ignore step a):

- a. Turn the shipping container right side up and carefully cut the binding tape and open the container.

CAUTION

Use reasonable care in opening the shipping container; sharp or pointed instruments may pierce the protective cover and scratch the finish of the computer.

- b. Note the method of packing, and remove all of the computer components except for the computer. Store pertinent papers in a safe place for future reference. Check the components with the Shipping Container Contents List which follows in this section.
- c. Gently tip the container on its side and slide out the computer chassis and the foam packing pieces. Place the chassis on a suitable work surface and replace the molded foam pieces in the container.

NOTE

It is not necessary to unlock the hard disk drive.

- d. Store the shipping container and the packing materials in a safe place. You will need these if you wish to ship the computer in the future.

SHIPPING CONTAINER CONTENTS LIST

The shipping container should contain:

Warranty Card

Manual review card. Please make note of questions and problems you have as you read this manual, and return the card to the ALTOS Publications Department. If you initially received a preliminary edition of the user manual, you will have a final manual request card. Return this card to Altos Computer Systems, Publications Department. When final manuals become available, yours will be sent to you at no charge, postpaid.

Hardware/Software Serial Number Note Card

As you unpack your hardware and software, please note all model, name, version and serial numbers for your records.

Quality Control Check Off List

Place this list in the pocket provided in the inside front cover of the user manual binder.

(If your Series 5 Computer was damaged in shipment, please see Appendix C.)

One Altos computer (Model 5-5D, or 5-15D).

One three-pronged power cord.

One floppy diskette containing the diagnostic programs used to test your computer system.

Either one 3A fuse (for 115 volt systems) or one 1.5A fuse (for 220 volt systems) and a fuse cap.

One operating system package containing the User Manual Subsection(s) and program floppy diskettes for the operating system(s) you selected when you purchased the computer system.

The following operating systems are available for Series 5 computer system models.

- a. CP/M is a basic operating system that supports a single user system.
- b. MP/M II is a multiuser version of CP/M.
- c. OASIS supports more system features, and can be used on both single and multiuser systems.

ITEMS YOU MUST SUPPLY

A keyboard CRT terminal (minimum of one, maximum of 3).

Serial data transmission rate of 9600 baud is required for console number 1.

A printer (dot matrix or impact quality print)

This is optional and is not required for elementary system operation. RS-232-C serial or Centronics parallel interface, one or two (one serial and one parallel interface) printers can be supported depending on the operating system used.

Interface Cables for the Terminal and Printer

NOTE

To maintain F.C.C. Class A compliance and limit possible radio/TV interference, all interface cables should have a grounded shield and be electrically and mechanically secured to the units to when they are connected.

SYSTEM CONFIGURATION

You will have to configure your system if you are adding a peripheral to your system, or if your system has not already been configured for the peripheral devices comprising it.

Your Series 5 Computer is configured for immediate use, no jumper configuration is required. As shipped, the system is initialized for RS-232-C serial interfacing, with Data-Terminal-Ready (DTR) handshaking. The network interface and Request-to-send (RTS), Clear-to-Send (CTS) handshaking is disabled. (Refer to Appendix D and the schematics for specific pinning details.

SETTING UP YOUR COMPUTER SYSTEM

Now you are ready to install fuses and power cords, and connect terminals and printers to your computer. Follow this procedure to hook up your computer system.

1. Verify that the power specifications on the serial identification tag match the voltage you are using.
2. Insert the fuse provided with your computer system in the rear panel fuse outlet and attach the fuse cap.
3. Install the three pronged power cord provided with your computer system. ALTOS recommends that you dedicate a power outlet to the sole use of your computer. This dedicated line minimizes the transient power surges and overloads that may occur on that outlet. The line voltage requirements are 110 VAC (plus-or-minus 10%) or 220 VAC (plus-or-minus 10%) with a frequency range of 47 to 63 Hz.
4. Verify console configuration and check interface cable construction. The series 5 computer RS-232-C serial ports are configured as follows.
 - a. One Start and one Stop bit.
 - b. No Parity
 - c. Eight bit word length

NOTE

To maintain F.C.C. Class A compliance and limit possible radio/TV interference, all interface cables must have a ground shield for all conductors. All cables should be fastened with the connector retaining screws to provide a proper shield ground path.

The ALTOS connector is wired as a modem with the following RS-232-C connection wiring required.*

- PIN 1	Chassis Ground*✓
- PIN 2	Transmitted Data
- PIN 3	Received Data ✓
PIN 4	Request-to-Send (optional - requires jumpering)
PIN 5	Clear-to-Send
PIN 6	N/C
PIN 7	Signal Ground✓
PIN 8	+12 V.P.C.
PIN 9	N/C
PIN 10	N/C
PIN 11	N/C ✓
PIN 12	N/C
PIN 13	N/C
PIN 14	N/C
PIN 15	N/C
PIN 16	N/C
PIN 17	N/C
PIN 18	N/C
PIN 19	N/C
- PIN 20	Data-Terminal-Ready (DTR)

Your ALTOS computer under Altos Diagnostics, CP/M and MP/M operating systems uses DTR handshaking with pin 20 and requires a minimum cable of pin 1, 2, 3, and 20 for proper operation.

The OASIS Operating System initially requires no hand shaking, hand shaking protocols may be invoked from the command level or via system generation. OASIS requires a minimum cable of pins 1, 2, and 3 for proper operation.

Most RS-232-C interface cables can be easily made using male shielded RS-232-C 25-pin D type connectors, connecting the pins in a pin-#1-to-pin#1 correspondence. All cables should be fastened with connector retaining screws to provide a proper shield ground path.

IMPLEMENTATION:

The following list defines the pin to pin connections for the cable connecting the Altos computer to the parallel printer.

ACS	PRT	SIGNAL NAME
1	1	Data strobe
2	2	Data 0
3	5	Data 3
4	3	Data 1
5	8	Data 6
6	9	Data 7
7	10	Acknowledge (currently optional)
8	11	Busy
9	4	Data 2
10	6	Data 4
11	7	Data 5
13	13	Select
15	12	Paper empty
17	31	Input prime (currently optional)
19	17	Ground
20	19	Ground
21	20	Ground
22	23	Ground
23	21	Ground
24	26	Ground
25	27	Ground
27	28	Ground
28	29	Ground
29	22	Ground
30	24	Ground
31	25	Ground
32	16	Ground
33	30	Ground
34	32	Fault

Use 35-pin D type connector in the construction of the parallel interface connector. See Appendix for the following CRT's and printers:

- a. Altos -1
 - b. Televideo
 - c. Falco
 - d. Lear-Siegler
 - e. Hazeltine 1500
5. Install the interface cables and power cords for the terminal and printer. Connect a data cable between the RS-232-terminal Serial connector port (JC) and the RS-232-C port on your terminal. Connect the proper data cable between the printer and the J9 connector port for serial type interfaces and/or JE connector port for

parallel type Centronics printer interfaces. (See Table 2-1 for port locations on the rear panel.)

Table 2-1. Back Panel Designations and Connections

DESIGNATOR	CONNECTIONS
F1	FUSE
AC INPUT	AC POWER
JA	SERIAL PRINTER
JB	CONSOLE #3 (OASIS SIO4)
JC	CONSOLE #1 (OASIS SI01)
JD	CONSOLE #2 NETWORK (OASIS SIO3)
JE	PARALLEL PRINTER (OASIS LP)
JY	SECOND HARD DISK
JZ	SECOND HARD DISK

TURNING ON YOUR SYSTEM

Now that you have hooked up the system peripherals, you are ready to apply power to your computer system. Follow this procedure to initialize your computer system.

1. Check the floppy disk drive(s) to make sure that they are clear. Remove shipping card board.
2. Turn on the terminal before you power up the computer. This allows you to observe output from the computer at power up.
3. Turn on the computer. You will see the following screen prompt when you power up your system. Press [SYSTEM.RESET] momentary switch on the upper right corner of the front panel if this prompting display does not appear.

@@ SELF TEST COMPLETED

ALTOS COMPUTER SYSTEMS
MONITOR VERSION X.XX

BOOTING FROM FLOPPY DISK

INSERT FLOPPY DISK FOR AUTOLOAD

(where X.XX is the current version of the EPROM monitor program)

5. The program responds by prompting you to insert a floppy diskette into THE RH drive.

You have now unpacked and set up your computer system, and turned it on. Make backup copies of your diagnostic diskettes. You are ready to test the system components to assure that they operate properly. The testing programs you will use are contained on the ADX Diagnostic disk that came with your system. The command programs it contains should be run before you load your operating system disk. Diagnostic procedures are covered in Section 3.

SECTION 3. DIAGNOSTICS

GENERAL INFORMATION

This section will serve to introduce you to SUPPLEMENT 3. EXECUTING DIAGNOSTIC PROGRAMS which accompanies your Series 5 Computer System. That supplement instructs you in running the individual diagnostic programs and performing all preparatory operations before installing your operating system.

SECTION 4. OPERATING SYSTEMS

GENERAL INFORMATION

This section serves to introduce you to one or more versions of SUPPLEMENT 4. INSTALLING THE OPERATING SYSTEM, each of which contains all the information necessary for you to install the subject operating system after the diagnostics have been successfully executed.

One or more supplements will be provided with each Series 5 User Manual. (You will get only the Operating System Supplement related the Operating System you buy: (CP/M, MP/M, or OASIS).

The required vendor manuals related to your operating system(s) are also provided.

SECTION 5. ALTOS UTILITIES

GENERAL INFORMATION

This section will introduce you to SUPPLEMENT 5. ALTOS UTILITY PROGRAMS which accompanies you Series 5 Computer System. That supplement provides descriptive and instructive information related to whatever utility programs are available at the time of printing this manual.

SECTION 6. UPGRADE KITS AND ADD KITS

(NOTE: THIS INFORMATION WAS STILL BEING DEVELOPED WHEN THIS REVISION WAS PRINTED.)

SECTION 7. HARDWARE OPERATING SPECIFICATIONS**SUMMARY OF SPECIFICATIONS**

Model: Series 5-5D, Series 5-15D

Computer:

CHIP SET:

Z80A (4Mhz): CPU, DMA, CTC (X2), PIO (X2), SIO (X2).
FD1797 floppy disk controller.

I/O PORTS:

4 Serial (RS-232C). One of these ports can alternatively function as a high speed, multi-drop network port. Another is re-configurable for bisync operation.

1 Parallel port configured to support a printer with a standard parallel interface such as Centronics uses.

SYSTEM MEMORY:

4K boot PROM that is switched out of memory space following initial program load.

192K of dynamic RAM based on 64K chips with parity.

Mass Storage:

Series 5-15D; Two Control Data 9409T, 5-1/4" flexible Disk Drive. Has expansion capabilities for one add-on 5-1/4" hard disk drive.

Series 5-5D; One Control Data 9409T, 5-1/4" flexible Disk Drive and one Seagate Technology ST506 Micro-Winchester. Has expansion capabilities for one additional add-on Seagate Technology ST506 Micro-Winchester 5 1/4" hard disk drive.

DETAILED COMPUTER SPECIFICATIONS

System Memory

MEMORY MAPPING

System memory is composed of 192K of dynamic RAM that is mapped or partitioned into one common or shared area and four user areas. The size and placement of these areas is determined by code in a PROM. The common area can be from 4K to 60K in 4K increments and can be placed anywhere in the Z80's 64K address space, but must begin and end on 4K boundaries. Each user area can take up the address space not occupied by the common area. Only one user area can be accessed at a time. The active user area is set by writing a bank select number to port 09. The user area for banks 0, 1, and 2 is 64K minus the common area, and for bank 3 twice the common area.

Mapping is done with a PROM that contains three different configurations; one for MP/M, one for multiuser OASIS and the third for diagnostics. Two bits outputted through port 09 (MM2 at bit 1 and MM1 at bit 2) control which of these maps is selected. Initially, following power on, both of these bits are set to 0 and the memory map is set for diagnostics. Following is a summary of memory configuration vs MM2 and MM1 bits:

MM2	MM1	Memory configuration
0	0	Diagnostics
0	1	OASIS
1	0	MP/M
1	1	(unassigned)

The memory configuration for MP/M sets the common area at C000 to FFFF, banks 0, 1, and 2 from 0000 to BFFF and bank 4 from 4000 to BFFF.

For OASIS the common area is set to 0000 through 4FFF, banks 0, 1, and 2 from 5000 to FFFF and bank 4 from 5000 to EFFF.

BANK SELECTION

Bank selection is done by writing to the PIO at port 09. UN1 and UN2 select the bank that the CPU addresses, UN3 and UN4 select the bank that the DMA addresses. Having separate numbers for the CPU and DMA permits the CPU to do processing while a sector is being located on a disk without waiting for the disk access to complete, (i.e., transfer from disk is done via the DMA).

WRITE PROTECTION

The memory has a write protect feature wherein if the write protect bit (WPRT, bit 5 at port 09) is set, the common area cannot be written into by the CPU. Writes by the DMA, however, are not inhibited. Following power on or reset this bit gets cleared and must be written again to inhibit writes.

PARITY

The dynamic memory circuit has a ninth bit added to each byte for the purpose of parity checking. If an error occurs, the Non-Maskable Interrupt (NMI) input to the CPU is pulled and the boot PROM switched back in. Code in the PROM notifies the user of a parity error.

Boot PROM

To allow initialization of the system, a 4K by 8 bit PROM is switched into memory space following initial power on or reset. This PROM acts as a "shadow PROM" in that it occupies system memory address space when "on" but can be switched off to accomodate a full 64K of read/write memory (RAM). By writing (anything) to port 14H, the PROM is switched out. Once out, the PROM cannot be switched in again by program control.

The PROM, when "on", occupies addresses from 0000 to 0FFF. From 1000 to 1FFF the system RAM memory is accessed. In addition, RAM addresses from 0000 to 0FFF can be written (but not read) until the PROM is switched off. From 2000 on, the PROM data is replicated as can be seen from the following table:

Memory Address	Physical memory read from	Physical memory written to
0000-0FFF	PROM 0000-0FFF	RAM 0000-0FFF
1000-1FFF	RAM 1000-1FFF	RAM 1000-1FFF
2000-2FFF	PROM 0000-0FFF	RAM 2000-2FFF
3000-3FFF	RAM 3000-3FFF	RAM 3000-3FFF
etc.		

Floppy Disk Controller

The floppy disk controller resides on the main processor board. It uses the Western Digital FD1797 controller chip and has the additional hardware needed to time out for seek settle, and erase head turn off.

The controller is capable of supporting two floppy drives, but the rear panel connector and cable required for an external drive is not provided.

Hard Disk Controller

The hard disk controller resides on a separate board from the processor. It interfaces to the processor board through a 34 lead flat ribbon cable, to the internal hard disk drive through a 20 lead (radial) cable and a 34 lead (daisy-chain) cable, and to a possible external hard disk drive through another 20 lead cable which terminates at the rear panel in a 25 pin D connector (JY) and an extension of the 34 pin cable which also terminates at the rear panel in a 37 pin type D connector (JZ). D connectors are used to facilitate shielding these cables through the retaining screws.

To accommodate the next generation of drives with programmed seek capability for improved access time, the controller can be modified to output buffered seek pulses to the drive by making two cuts and adding two jumpers at S4 and S5.

To accommodate the requirements of different vendor's drives, jumpers on the PCB allow independent selection of the cylinder at which write current precompensation and write timing precompensation take place (S1). Drives with different precompensation requirements cannot be mixed on one controller, so if an ADD is used, the added drive must match the internal drive.

One external hard disk (ADD-5) can be supported. As noted, it must have the same write precompensation and seek timing requirements as the internal drive.

Sector size is selectable between 256 and 512 by two jumpers at S2. MP/M and OASIS only support 512 byte sectors.

I/O Ports

There are four serial ports using SIOs that are buffered for RS-232C operation. Alternatively, one of the SIO ports (port address 2C at JD) can be used as a multi-drop network port at 800K baud. This SIO is able to request the DMA to sustain this high speed operation. This port is changed from an RS-232C port to a network port by the removal of the 1488 and 1489 (RS232-C line drivers and receivers), the insertion of an 26LS31 and 26LS32 (RS422 line drivers and receivers) and the changing of several jumpers on the processor board.

Another of the serial ports (port address 1C at JB) can be configured to accept external transmit and receive clocks to facilitate bisynchronous operation. This is done by changing two jumpers, S35 and S36.

Two of the serial ports have independently programmable baud rates to 9600 baud (console 1 and printer 1). For higher baud rates, provision is made to install a DIP packaged oscillator which can be used to clock either console 1 or the printer when jumpers S31 and S32 are changed from B to A. Jumper S31

controls the clock for the printer, and S32 controls the clock for console 1 (Motorola K115A crystal oscillator 308 KHz). The other two serial ports share a common programmable baud rate to 9600 baud (consoles 2 and 3). The RS232 ports support a DSR-DTR handshake. By changing shunts, CTS-RTS can be used. SIGNAL DETECT is held true.

One PIO is used to support an 18 line parallel port. This port is buffered to interface to a Centronix type printer. The connector is a 37 pin 'D', JE on the rear panel.

Configuration Port

The three least significant bits at port 08 are set aside to provide information on the configuration of the system. The significance of bit 2 has not been assigned. Bits 1 and 0 define the number of hard disks attached to the processor as follows:

Bit 1	Bit 0	Meaning
1	1	No hard disks
1	0	A hard disk at drive 1 (either internal as for a -5 or external as for an UK-5)
0	0	Hard disks at drive 1 and drive 2 (i.e., an -5 with an ADD-5)

I/O Port Assignment

PORT NUMBER	SCHEMATIC REFERENCE	FUNCTION
00-03	Y0 (DMA)	Initialize DMA.
04	Y1 (FD1797)	Input: drive/controller status. Output: commands to drive/controller.
05	(floppy disk)	Input/output: track number.
06		Input/output: sector number.
07		Input: data. Output: data when WRITING to the disk and the desired track number prior to doing a SEEK.
08	Y2 (PIO-CHA)	Input: interrupt from the floppy disk and configuration information. Output: floppy disk drive select, side select and recording density.
09	Y2 (PIO-CHB)	Input: interrupt from the hard disk. Output: memory bank select, write protect and memory mapping bits.
0A	Y2 (PIO-CHA)	Initialize channel A.
0B	Y2 (PIO-CHB)	Initialize channel B.

0C	Y3 (CTC-CH0)	Baud rate generator for console number 1 at JC.
0D	Y3 (CTC-CH1)	Baud rate generator for consoles 2 and 3 at JB and JD.
0E	Y3 (CTC-CH2)	Baud rate generator for printer at JA.
0F	Y3 (CTC-CH3)	Real time clock.
10	Y4 (PIO-CHA)	Parallel port I/O (normally used in I/O mode).
11	Y4 (PIO-CHB)	Parallel port I/O (normally used for data in an I/O mode).
12	Y4 (PIO-CHA)	Initialize channel A.
13	Y4 (PIO-CHB)	Initialize channel B.
14-17	Y5 (IPL)	IPL switch, an output to any of these ports turns off the PROM and enables system RAM (done after IPL).
1C	Y7 (SIO-CHA)	Input/output: data to I/O port at JB (normally console number 3, also bisync port).
1D	Y7 (SIO-CHA)	Input: status of channel A. Output: commands to CH A.
1E	Y7 (SIO-CHB)	Input/output: data to I/O port at JA (normally printer).
1F	Y7 (SIO-CHB)	Input: status of channel B. Output: commands to CH B.
20	Y8 (HD DSK)	Output: head number to the hard disk controller.
21	"	Output: old cylinder number prior to a SEEK, sector number prior to a READ and input/output: data (via the DMA only) during data transfer to the hard disk controller.
22	"	Output: new cylinder number to the controller.
23	"	Input: drive/controller status. Output: commands to drive/controller.
2C	Y11 (SIO-CHA)	Input/output: data to I/O port at JD (normally console number 2). Also, I/O data to network port.
2D	Y11 (SIO-CHA)	Input: status of channel A. Output: commands to CH A.
2E	Y11 (SIO-CHB)	Input/output: data to I/O port at JC (normally console number 1).
2F	Y11 (SIO-CHB)	Input: status of channel B. Output: commands to CH B.

Bit Assignment for the I/O Ports

PORT	BIT	DESCRIPTION
00-03 (DMA)		(Not applicable).
04-07 (FD1797)		(See the Western Digital data sheet).
08 (PIO-CHA)	7	Floppy disk controller interrupt input, positive true.
	6	Floppy drive side select output, 0=side 0, 1=side 1.
	5	Floppy drive select output, 0=Drive 1, 1=Drive 2.
	4	Floppy disk drive recording density output (DDEN), 0=single, 1=double.
	3	Two-sided diskette (TS), input from floppy disk drive. 0=single, 1=two-sided.
	2	Configuration bit, unassigned.
	1	Configuration bit, indicates presence of a second hard disk. 1=not present, 0=present.
	0	Configuration bit, indicates presence of a hard disk at drive 1. 1=not present, 0=present.
09 (PIO-CHB)	7	UN4, MSB of DMA memory bank select nibble.
	6	UN3, LSB of the above.
	5	WPRT, write protect bit. When set to a 1 this bit prevents writes into the common memory space.
	4	UN2, MSB of CPU memory bank select nibble.
	3	UN1, LSB of the above.
	2	MM1, LSB of memory mapping nibble.
	1	MM2, MSB of the above.
	0	HDINT, hard disk controller interrupt input.
0C (CTC-CH0)	In	2Mhz.
	Out	Baud rate for channel B of the SIO that outputs to JC (console number 1).
0D (CTC-CH1)	In	2Mhz.
	Out	Baud rate for channels A of the SIOs that output to to JB and JD (consoles number 2 and 3).
0E (CTC-CH2)	In	2Mhz.
	Out	Baud rate for channel B of the SIO that outputs to JA (printer).
0F (CTC-CH3)	In	2Mhz.
	Out	(none, used for real time clock).

10 (PIO-CHA)	7	(Unnamed) normally an input from printer to PIO
	6	SELECT, "
	5	BUSY, "
	4	PAPER EMPTY, "
	3	FAULT, "
	2	CNTL, normally an output to the printer.
	1	INPUT PRIME, "
	0	DATA STROBE, "
11 (PIO-CHB)	7	DATA 7, normally an output to the printer.
	6	DATA 6, "
	5	DATA 5, "
	4	DATA 4, "
	3	DATA 3, "
	2	DATA 2, "
	1	DATA 1, "
	0	DATA 0, "
14-17 (IPL)		(Not applicable).
1C (SIO-CHA)		(Not applicable).
1E (SIO-CHB)		(Not applicable).
20-23 (Hard disk)		(See the HARD DISK interface specification).
28 (SIO-CHA)		(Not applicable).
2A (SIO-CHB)		(Not applicable).
2C (SIO-CHA)		(Not applicable).
2E (SIO-CHB)		(Not applicable).

Interrupt Priority Daisy Chain

Y0	00	(DMA)	Highest priority
Y2	08	(PIO, floppy disk interrupt)	
Y4	10	(PIO, hard disk interrupt)	
Y3	0C	(CTC, baud rates)	
Y7	1C	(SIO, console 3)	
Y11	1E	(SIO, printer)	
	2C	(SIO, console 2)	
	2E	(SIO, console 1)	Lowest priority

Mass Storage DevicesFLOPPY DISK DRIVE SPECIFICATION SUMMARY FLEXIBLE DISK DRIVE
(CONTROL DATA 9409T 5 1/4")

Performance Specifications

Capacity:

Unformatted Double Density

Per Disk	1 Megabyte
Per Track	6.25 Kilobytes

Altos Format (CP/M, MP/M)

Per Disk	737 Kilobytes
# of Cylinders	80
# of Head/Cyl.	2
# of Sectors/track	9
Sector Size	512 Bytes
Block Size	4 Kilobytes
# of Files	180

Altos Format (OASIS)

Per Disk	655 Kilobytes
# of Cylinders	80
# of Head/Cyl.	2
# of Sectors/track	16
Sector Size	256 Bytes
Default Directory Size	240 Files

Transfer Rate	250 Kilobytes/sec.
---------------	--------------------

Latency (average)	100 msec.
-------------------	-----------

Access Time

Track to Track	6 msec.
Average	132 msec.
Head Load Time	50 msec.
Settle Time	15 msec.

Functional Specifications

Disk Diameter	5 1/4"
Rotational Speed	300 RPM
Track Density	96 tpi
Total Tracks	160 (80 per side)
Encoding Method	MFM
Index Holes	1

Error Rates

Soft Read Errors	1 per 10^9
Hard Read Errors	1 per 10^{12}
Seek Errors	1 per 10^6

HARD DISK DRIVE SPECIFICATION SUMMARY (WINCHESTER TYPE FIXED DISK) SEAGATE TECHNOLOGY (ST506 MICROWINCHESTER)

Performance Specifications

Capacity:

Unformatted

Per Drive (Mbytes)	6.38
Per Surface (Mbytes)	1.59
Per Track (kbytes)	10.416

Formatted

Per Drive (Mbytes)	5.3
Per Surface (Mbytes)	1.25
Per Track (kbytes)	8.192
Per Sector (bytes)	256
Sectors/track	32

Logical drive formats for CP/M and MP/M:

Capacity (Mbytes)	5.3
Number of Logical Devices	1
Block Size	4 Kilobytes
# of Cylinders	152*
# of Head/Cylinder	4
# of Sectors/Track	17
Sector Size	512 Bytes
# of files	1275

Logical drive formats for OASIS:

Capacity (Mbytes)	5.3
Number of Logical Devices	1
# of Cylinders (Data)	152*
# of Heads	4
# of Sectors/Track	34
# of Bytes/Sector	256
Default Directory Size	1984 Files

- * There are 153 cylinders, the first cylinder is reserved for system use for alternate sector assignments.

Transfer rate	5.0 Megabits/sec.
Access Time	
Track to Track (ms)	3
Average (ms)	170
Maximum (ms)	500
Settling Time (ms)	15
Average latency (ms)	8.33

Functional Specifications

Disk diameter	5 1/4"
Rotational Speed (rpm)	3600 RPM
Recording Density (bpi)	7690
Track Density (tpi)	255
Number of surfaces	4
Number of Disks	2
Number of R/W heads	4
Number of Cylinders	153
Number of Tracks	612

Error Rates

Soft Read Errors	1 per 10^{10} bits read
Hard Read Errors	1 per 10^{12} bits read
Seek Errors	1 per 10^6 seeks

GENERAL PHYSICAL SPECIFICATIONS

Environmental Requirements

	Operating	Shipping	Storage
Temperature (host ambient -F)	40 to 115	-40 to 144	-40 to 144
Relative humidity (range F)	20 to 80%		
Maximum wet bulb	78 F non-condensing		

AC Power Requirements:

Series 5-15D

100/115 VAC Installations =	1.4	Amps. Maximum
	1.0	Amps. Nominal
200/230 VAC Installations =	0.7	Amps. maximum
	0.5	Amps. nominal

Series 5-5D

100/115 VAC Installations =	2.0 Amps. Maximum
	1.31 Amps. Nominal
200/230 VAC Installations =	1.0 Amps. maximum
	0.65 Amps. nominal

Physical Dimensions:

Height (all)	6.25 inches
Width (all)	13.5 inches
Length (all)	17.0 inches

Weight:

	Series 5-5D	Series 5-15D
System	24.5 lbs.	26.5 lbs.
Shipping	36 lbs.	36 lbs.

Jumpers on the CPU Board (11073)

Jumpers are used on the CPU board for several reasons: 1) to indicate the system configuration (1, 2 and 3), 2) to assist in testing or debugging the board itself (4 and 42), 3) to reconfigure the operation of the serial ports (6 through 40), 4) to allow the floppy disk controller to operate with either 5.25 inch or 8 inch drives (A through L) or 5) to allow a smaller boot PROM (2716) to be used (J).

SYSTEM CONFIGURATION JUMPERS

Slide-on jumpers at 1, 2, 3 of 7D are used to indicate the system configuration. Logic level is a 1 without jumper a 0 with a jumper. (See page 7-5 for assignment.)

DEBUGGING AIDS JUMPERS

The slide-on jumpers at 4 of 11D and 39 of 11T when removed place the data buffers in a high impedance state to assist in testing. Shipped with the jumpers in place.

The slide-on jumper at 42 of 10C when installed prevents parity errors from controlling the NMI input to the CPU. Used to assist in debugging memory. Shipped with the jumper removed.

SERIAL PORT CONFIGURATION JUMPERS

Network Port Enabling Jumpers

The system is shipped with the connector at JD configured for RS 232C operation. This requires a 1488 at location 1V, a 1489 at location 2V, locations 4U and 4V vacant, jumpers at 6, 8, 10, 11, 13, 15 and 20, with the remaining jumper slots open.

JD can be reconfigured for network operation by removing the devices at locations 1V and 2V, installing an 26LS31 at 4V, installing a 26LS32 at 4V removing all the above jumpers and installing them at 6, 7, 9, 12, 14, 16, 17, 18, 19, 21, 24, 22 and 23.

RTS/CTS Loop Enabling Jumpers

JC (console #1) can be configured to operate with the RTS/CTS loop operational by jumpering 40 to B and 41 to A. Normally shipped with this loop defeated, 40 to A and 41 to B.

JD (console #2) can be configured to operate with the RTS/CTS loop operational by removing jumpers 6 and 8 and installing them at 5 and 7.

JB (console #3) can be configured to operate with the RTS/CTS loop operational by jumpering 34 to B and 33 to A. Normally shipped with this loop defeated, 34 to A and 33 to B.

JA (printer) can be configured to operate with the RTS/CTS loop operational by jumpering 38 to A and 37 to B. Normally shipped with this loop defeated, 38 to B and 37 to A.

Optional On-Board Baud Rate Generator Jumpers

Console number 1 and/or the printer can be operated at baud rates other than can be derived from the on-board CTC. This is done by adding a DIP packaged oscillator at 11U and changing the jumpers at 31 and/or 32 to the A position. These are normally shipped with the jumpers in the B position.



Preliminary Series 5 Computer System Supplement 3. Executing Diagnostic Programs

Revision D
February 26, 1982

Disclaimer

This is a preliminary publication of the ALTOS Series-5 Computer System Documentation and is presented for information purposes only; it will be changed without notice.

The information contained herein represents the most current information available at the time of printing, however, the information has not been thoroughly reviewed nor has it been approved in its present form. ALTOS Computer Systems assumes no liability whatever related to use of information presented in this publication.

NOTE

This revision replaces but does not
obsolete previous revisions
of this document.

TABLE OF CONTENTS

GENERAL INFORMATION	S3-1
KNOWN SYSTEM DEFICIENCIES	S3-1
ADX PROGRAM FUNCTIONS	S3-2
Loading and Running the ADX Program	S3-2
Making Back-up Copies of the ADX Diskette	S3-3
ADX PROGRAM TESTING ORDER	S3-7
DIAGNOSTICS PROGRAM REVIEW	S3-7
DISKETTE FORMAT AND DISKETTE COPY UTILITY PROGRAMS	S3-7
The MFORMAT Utility (Mini FORMAT)	S3-7
The BOOTCOPY Utility	S3-8
Using the COPY Utility	S3-9
Documentation for HRDINIT5	S3-10
Procedure for Running HARDINIT5	S3-10
FLOPPY DISK DRIVE TESTING PROGRAMS	S3-10
Mini Floppy Test (MFT)	S3-10
Running MFT	S3-11
Displaying Errors	S3-11
Continuously Write a Sector	S3-12
Continuously Read a Sector	S3-13
Reliability Test	S3-13
Continuously Write then Read One Track	S3-13
Motor Start Timing Test	S3-13
Exit Program	S3-13
Printer Test (PRNTEST)	S3-13
Memory Test (MEMTEST)	S3-14
HARD DISK TESTS AND FUNCTIONS	S3-15
Hard Disk Test (HARDS5)	S3-15
Format Disk Drive	S3-16
Verify Addresses for All Sectors on Disk	S3-17
Seek Test with Optional Verify	S3-17
Write Entire Disk	S3-18
Read Entire Disk	S3-19
Option Descriptions	S3-19
Set Flag Byte for a Specific Sector	S3-20
Hard Disk Read/Write Error Test	S3-21
Miscellaneous Functions	S3-23

ALTOS SERIES 5 COMPUTER SYSTEM**SUPPLEMENT 3. EXECUTING THE ALTOS DIAGNOSTIC
EXECUTIVE PROGRAM (ADX)****GENERAL INFORMATION**

This supplement provides instructions for executing diagnostic programs to prepare your system for installing the operating system and the selected application programs.

This supplement also presents the ADX program diskette loading procedure, and reviews ADX program functions.

KNOWN SYSTEM DEFICIENCIES

At the time this preliminary manual was printed, the following system deficiencies were known:

1. There is no way to change baud rates or use a parallel printer with ADX. Use only 9600 baud terminals and serial printers.
2. There is no Direct Memory Access (DMA) or memory write-protect test.
3. The system will hang (possibly with a memory parity error) if "9" is entered to exit from HARD5. Reboot the system to exit from HARD5.
4. HRDINIT5 does not return to the ADX menu. Reboot the system to exit from HRDINIT5.
5. The self-test will run spontaneously sometimes when the system is booted after running ADX.
6. COPY and BOOTCOPY do not yet verify the data on the destination disk.

ADX PROGRAM FUNCTIONS

The ADX master diskette that came with the system contains a group of command programs that test Series 5 computer system components, format diskettes, and copy programs. These programs comprise the ALTOS Diagnostic Executive program (ADX). The ADX program must be run the first time the computer system is powered up, and every time a new component is added to the system.

WARNING

You should make a backup copy of this diskette before proceeding to test system components. To insure protection of your master diskette, you should make at least two copies. One copy, the ADX system diskette, is for daily use. The other, the back-up master, is only for making additional copies for daily use. You should never use your Altos master diskette for daily operations. It should be stored away from your computer area in a secure location to prevent accidental use.

The utilities and tests comprising the ADX program are grouped into three categories, described in this section. Each program prompts you for every operation you need to perform. The programs perform these following functions:

1. They format diskettes and copy diskette utilities.
2. They test computer memory, printer, terminal, and floppy drives.
3. They test hard disk functions.

Loading and Running the ADX Program

Follow the power up procedures listed in Section 1 of this manual. Your system should be unpacked. System components should be cabled together. You should see a display prompting you to insert a floppy diskette into the floppy drive after you turn on your system.

Place your ADX diskette with the label facing up into the RH floppy disk drive. Close the door of the disk drive unit, and the diagnostics program loads automatically. After loading the diagnostics diskette, your terminal screens the following display.

Altos ADX 3.0
 ALTOS DIAGNOSTIC MONITOR VERSION 3.0

```
***D I A G N O S T I C   C O M M A N D   D I R E C T O R Y***
      MFORMAT      BOOTCOPY      PRNTEST      MEMTEST
      MFT          COPY          HRDINIT5     HARDS5
```

REQUEST:

You must always load ADX programs into the RH drive. Note that default logical Drive A will always be a floppy disk drive. It is possible to pin the floppy disk drive in many ways, but you must still load the operating system disk into logical drive A. Normally (standard factory configuration) logical drive A is the right-hand side drive as you face the front.

Making Back-up Copies of the ADX Diskette

For all Series 5 Computers:

Have at least two new blank 5 1/4" floppy diskettes. The disk drive vendor for all Series 5 models has qualified VERBATIM model number MP557-01-18242 Data Life 5 1/4" diskettes. These diskettes are 5 1/4", 96 track per inch, double density, double sided, soft sector diskettes.

With the ADX Master diskette loaded and with the Diagnostic Command Directory menu displayed, type "MFORMAT" after the "REQUEST" prompt. The terminal will display the following MFORMAT prompts:

```
ALTOS 5 1/4 INCH FLOPPY FORMAT FACILITY
Insert diskette to be formatted in available drive
Remove system disk if necessary
Enter drive letter to continue      A/B?
```

Type A for the right hand side drive or B for the left hand side floppy disk drive (Series 5-15D only). The system will respond by counting the diskette cylinders as they are actually formatted with the following prompt:

```
Cylinder XX      (where XX is a cylinder number from 0 to 79)
```

After completing the format for cylinder 79 the utility will finish and prompt you for repeating the format task, in the following manner:

```
Would you like to format another diskette?  Y/N
```

At this point remove the diskette from the disk drive and label it "ADX Backup Master" and set it aside.

WARNING

Use only felt tip pens when writing on a floppy diskette. The use of a pencil or a ball point pen can cause indentations on the surface of the diskette which will cause media related errors during use. Preferably prepare and write on your label before you place it on the diskette.

To make the ADX System Diskette, the one to be used in daily use, insert the second blank diskette and type "Y" to the prompt. The original prompt will be repeated, respond in the same manner as you did before. Upon completion remove diskette and label it properly.

Respond with a "N" to the "Would you like to format another diskette? " Y/N" prompt to exit the MFORMAT utility. In response to the next prompt displayed:

System disk in drive A
Enter to continue.....

Insert the ADX Master diskette and depress the return key on the keyboard of your terminal " [RETURN] ". This return you back to Diagnostic Command Directory.

For Series 5-15D system perform the following steps to actually make the copy:

Type "COPY" after the "REQUEST" prompt. The terminal will display the following prompt:

Altos 5-1/4 inch disk copy program
Insert source in drive A
Insert object in drive B
Type return

Make sure that the ADX Master diskette is in the right hand side drive (drive A). Insert the formatted diskette labeled "ADX Backup Master" in the left hand side drive (drive B) and then depress the return key on the keyboard of your terminal " [RETURN] "

When copy is finished, it returns back to the Diagnostic Command Directory. Remove the diskette. Repeat the COPY operation for the second diskette.

NOTE

At this point store the original ADX Master diskette in a safe place away from the system work area. DO NOT USE THIS DISKETTE EXCEPT TO CREATE ADDITIONAL ADX BACKUP MASTERS, AND ONLY USE THE ADX BACKUP MASTERS TO CREATE ADX SYSTEM DISKETTES! The backup procedure for Series 5-15D systems is now complete.

For Series 5-5D systems perform the following steps to actually make the copy:

WARNING

A copy can be made of the ADX Master diskette only if you have a CP/M or MP/M operating system with a Series 5-5D system. CP/M or MP/M is required to make the backup copy. If you have the OASIS operating system only, you cannot make a copy of the ADX Master at this time, so use the ADX Master with caution and only after reading the instruction completely. This will be corrected at a later date, contact your distributor.

Type "HRDINIT5" to initialize the hard disk. Answer "Y" to the "Do you want to continue" prompt. HRDINIT5 takes about 5 minutes to complete. The Diagnostic Command Directory will be displayed when HRDINIT5 is finished.

Type "BOOTCOPY" after the "REQUEST" prompt. The terminal will display the following prompt:

Altos 5-1/4 inch boot copy program
Insert diskette to be read from and type CR

Depress the return key. The following prompt will then be displayed:

Insert diskette to be written to and type CR

Remove the ADX Master diskette from the right hand side drive (drive A) insert the formatted diskette labeled "ADX Backup Master." Then depress the return key on the keyboard of your terminal "[RETURN]"

When BOOTCOPY is finished, remove the diskette and insert either a CP/M or MP/M operating system diskette. Depress the System Reset push button switch to load the operating system. The final system prompt after "booting" will be:

A>

for CP/M or:

ØA>

for MP/M.

You need to copy all files from your CP/M or MP/M Master diskette to the hard disk logical drive B:, to do this type:

PIP B:=A:*. *[v] [RETURN]

after the A> or ØA> prompt. When the transfer is complete, log-on to logical drive B by typing B:[RETURN] after the A> or ØA> prompt; example for CP/M:

A>B: [RETURN]

or for MP/M

ØA>B: [RETURN]

Remove the CP/M or MP/M master diskette from the floppy disk drive and insert the ADX Master diskette.

To complete the copy function perform the next steps, in response to the system prompts:

B>PIP B:=A:*.DIA[v]

This will transfer all diagnostic files (MFORMAT.DIA, BOOTCOPY.DIA, PRNTEST.DIA, MEMTEST.DIA, HARDS5.DIA, COPY.DIA, HRDINIT5.DIA) from the ADX Master diskette to the hard disk. Upon completion, remove the ADX Master diskette from the floppy disk drive and replace it with the previously formatted and boot copied "ADX Backup Master" diskette. Next, transfer all diagnostic files back to the floppy diskette, again using PIP:

B>PIP A:=B:*.DIA[v]

Upon completion you will have completed the backup. At this point, remove the diskette from the drive and label it ADX System Master. Repeat this procedure to make the copy of your "ADX System" Diskette. Do not use your ADX Master, set it aside and use the ADX Backup master in it's place.

NOTE

At this point store the original ADX Master diskette in a safe place away from the system work area. DO NOT USE THIS DISKETTE EXCEPT TO CREATE ADDITIONAL ADX BACKUP MASTERS, AND ONLY USE THE ADX BACKUP MASTERS TO CREATE ADX SYSTEM DISKETTES! The backup procedure for Series 5-5D systems is now complete.

NOTE

After making your ADX backup remove all Diagnostic files from the hard disk by typing after the system prompt:

B>ERA *.DIA

Do not attempt to execute the ADX utility program from the CP/M or MP/M operating systems.

ADX PROGRAM TESTING ORDER

You should run ADX test programs in the following order to test and initialize system components. Refer to the next subsection for test program descriptions and operating procedures.

1. Run MEMTEST to test computer system RAM.
2. Run PRNTEST to test the printer interface.
3. Run MFT to test computer system floppy disk drives.
4. Run HARDS5 to test the computer system hard disk, if your Series 5 system has a hard disk.

The ADX program may include other programs depending upon how your system is configured.

DIAGNOSTICS PROGRAM REVIEW

This section describes each utility comprising the ADX diagnostic program, under these three section headings.

1. System set up, diskette format and diskette copy programs.
2. Floppy disk drive testing programs.
3. Hard disk drive testing programs.

The ADX program may include other programs depending upon how your system is configured.

DISKETTE FORMAT AND DISKETTE COPY UTILITY PROGRAMS**The MFORMAT Utility (Mini FORMAT)**

The MFORMAT utility program either formats or reformats diskettes. This program erases all data stored on an old diskette.

The disk drive vendor for all Series 5 models has qualified VERBATIM model number MP557-01-18242 Data Life 5 1/4" diskettes. These diskettes are 5 1/4", 96 track per inch, double density, double sided, soft sectored diskettes.

Follow this procedure to execute MFORMAT.

1. Insert the diagnostic diskette in the diskette drive. Press [SYSTEM.RESET]. The ADX Diagnostic menu will display on the terminal screen. Type "MFORMAT" after the "REQUEST" prompt. The terminal will display the following MFORMAT prompting message.

```
ALTOS 5 1/4 INCH FLOPPY FORMAT FACILITY
Insert diskette to be formatted in available drive
Remove system disk if necessary
Enter drive letter to continue      A/B?
```

Insert the blank disk into desired drive and close the loading door. Type A for the right hand side drive or B for the left hand side floppy disk drive (Series 5-15D only). The system will respond by counting the diskette cylinders as they are actually formatted with the following prompt:

```
Cylinder XX      (where XX is a cylinder number from 0 to 79)
```

After completing the format for cylinder 79 the utility will finish and prompt you for repeating the format task, in the following manner:

```
Would you like to format another diskette?  Y/N
```

At this point remove the formatted diskette from the disk drive, label it, enter "Y" for Yes if you wish to repeat or "N" to return back to the ADX Diagnostic menu.

The BOOTCOPY Utility

The BOOTCOPY program is designed for the Series 5-5D and the Series 5-10 computer systems. This utility will also work on the Series 5-15. It copies the autoboot system tracks (0 and 1) from a source disk, to any object disk that has already been formatted.

The following procedure prompts you to load a diagnostics diskette in drive A; then exchange the diagnostics diskette for a source diskette; then finally exchange the source diskette for the blank formatted diskette.

Follow the procedure below to execute the BOOTCOPY program.

1. Format a blank diskette using the MFORMAT program. This newly formatted diskette is the object diskette. To perform the

BOOTCOPY program, you will need the diagnostic disk, a source disk, and the object disk.

2. Insert the ADX diagnostic diskette in the diskette drive. Press [SYSTEM.RESET]. The ADX Diagnostic menu will display on the terminal screen. Type "BOOTCOPY" after the "REQUEST" prompt. The terminal will display the following prompt:

```
Altos 5-1/4 inch boot copy program
Insert diskette to be read from in drive A:  and type CR
Insert diskette to be written to in drive A:  and type CR
```

Insert the diskette and press RETURN.

Do you want to repeat, (Y/N)

After completion of the boot copy you will return back to the ADX Diagnostic menu, if you reply "N."

NOTE

At this point the object disk contains bootcopy tracks 0 and 1. It does not contain data. Use the PIP procedure outlined in the operating system section to copy or transfer program or data files from source disks to object disks.

Using the COPY Utility

The COPY performs a sector by sector copy of a CP/M or MP/M 5-1/4" diskette. This utility requires two floppy disk drives, therefore it can only be used on the Series 5-15D computer system.

The COPY utility requires a "source" and a previously formatted "object" disk to be copied.

Follow this procedure to execute the COPY utility program.

Load the ADX Diagnostic diskette into logical drive A. Press [SYSTEM.RESET]. The ADX Diagnostic menu will display on the terminal screen. Type "COPY" after the "REQUEST" prompt. The terminal will display the following prompt:

```
Altos 5-1/4 inch disk copy program
Insert diskette to be read from in drive A
Insert diskette to be written to in drive B
Type return
```

Insert the diskette you wish to copy in the right hand side drive (drive A). Insert the formatted "object" diskette in the left hand side drive (drive B) and then depress the return key on the keyboard of your terminal "[RETURN]".

After completing the copy, the utility will finish and prompt you for repeating the copy task. Remove the "source" and "object" diskettes. Type "Y" for Yes to repeat copying or type "N" to return back the Diagnostic Command Directory. This copy utility copies all areas on the disk, the AUTOBOOT portion as well as the data/program area.

Documentation for HRDINIT5

This program is provided on the diagnostic diskette. The program will not run under CP/M or MP/M.

The program should be run only once, unless the disk has been reformatted. Since the program will erase all files on the hard disk, back up all files to floppy disk, if required.

The program when run from a diagnostic diskette will initialize 5-1/4" hard disks. In the process of initialization the program builds bad sector information table, this table is written on the last sector of the first track of a particular disk drive. Up to two drives are supported.

Alternate sectors are allocated to bad sectors, the number of alternate sectors available is a function of the size of the drive involved. A fixed number of tracks in the beginning of the disk drive are reserved for use for alternate sectors.

Procedure for Running HRDINIT5

- 1) Boot from the diagnostic disk.
- 2) Request HRDINIT5 when the diagnostic directory is displayed.
- 3) Reply "Y." Do you want to continue?
- 4) If there is a request for a second drive, reply with appropriate number, after the system disk has been initialized.
- 5) Reboot the system.

FLOPPY DISK DRIVE TESTING PROGRAMS

These tests will not normally need to be run unless problems with the floppy diskette drives, printer, memory or the CPU PCB are encountered.

Mini Floppy Test (MFT)

The ADX MFT test program package tests the computer's floppy disk drive system. It consists of 7 tests. Run various test programs in this package if you suspect that you have a hardware-driven problem with your system.

Running MFT

You will need one formatted blank diskette for Series 5-5D (two for Series 5-15D) to use MFT. Using known good diskettes, format the diskettes on the drive to be tested using MFORMAT. Then run MFT function test C (listed on the MFT main menu) for at least 400 passes, if possible. There should be fewer than one error per pass.

If the number of errors per pass is greater than one, terminate the test and try new and different floppy diskette, to insure that you do not have defective media.

To run this test, insert the ADX copy diskette into logical drive A and depress the reset pushbutton. The diskette will boot up automatically, and display the Diagnostic Commands Directory. First, type MFORMAT after the REQUEST: prompt to format a blank diskette. Return to the Diagnostic commands directory after formatting a diskette, and type MFT after the REQUEST: prompt.

The MFT Main menu displays in a few moments. It prompts you to choose which floppy disk drive function to be tested. The most useful choice to make in most field situations is option c, RELIABILITY TEST, but other tests on the menu may also be chosen. The Reliability test should be run overnight, if possible; most other tests on the menu will take less time. All tests display screen prompts to guide you clearly through simple operating procedures.

Type S on the keyboard to generate a summary error display at any time during any function test you select in this program.

Type [ESC] to abort any function test at any time.

*****ALTOS 5.25 INCH FLOPPY TEST FACILITY *****

- a) Continuously write a sector
- b) Continuously read a sector
- c) Reliability test
- d) Continuously write then read one track
- e) Motor start timing test
- f) Exit program.

Displaying Errors

All MFT function tests seek, find, and report errors in the floppy disk system. Error information can be displayed in two different tables: The ERROR SUMMARY TABLE and the ERROR DISPLAY TABLE.

Type the letter S to call the error summary table. It can be called at any time from any function test on the MFT main menu. The error summary table tallies errors as an individual test

accumulates them. The summary table will not interrupt the test you are running.

Here is a list of error code definitions and suggested problem sources for the Error Summary Table.

1. CRC -- Cyclic Redundancy Check. This Error type shows that you are probably losing data integrity between the controller and the floppy diskette.
2. RNF -- Record Not Found. The sector address holding test data cannot be located.
3. SKV -- Seek/verify error. Unable to verify track number after seeking.
4. CMP -- Compare error. Loosing data integrity between the Floppy Disk Controller and Volatile memory.

The following screen displays, with a prompt for you to select the error display table.

	Drive A				Drive B			
	CRC	RNF	SKV	CMP	CRC	RNF	SKV	CMP
SOFT	0	0	0	0	0	0	0	0
HARD	0	0	0	0	0	0	0	0

Do you wish to display errors (Y/N)

The error display table is selected by answering Y (yes) to the prompt that appears at the bottom of the error summary table. It shows error types and the physical locations of errors on the diskette. It is best called toward the end of a test.

SOFT ERRORS	DRIVE	SIDE	TRACK	SECTOR	ERROR	PASS	OCCURRENCES
	1	0	23	4	CMP	0	2

Continuously Write a Sector

Enter A to select this first test. It prompts you first to enter the Drive, cylinder, head and sector number to be written to, and then to insert a formatted test diskette into the drive to be tested.

Continuously Read a Sector

Enter B to select this test. It prompts you first to enter the drive, cylinder, head and sector number to be read from, and then displays the contents of the sector.

Reliability Test

Enter C to select this test. Test accuracy increases greatly with the number of passes it has time to make over the test diskette. It should run for a few hours on a normal system; when setting up a system or locating major hardware/software interface problems, this test should be allowed to run overnight.

It first prompts you to select a drive number, and then to insert a formatted test diskette in the drive number selected. Next, it displays the Reliability Test Screen and begins to conduct a read/write error test. It displays errors in a table similar to the Error Display table.

Continuously Write then Read One Track

Type D to select this test. It first prompts you to select drive, cylinder and head numbers, and then to insert a formatted test diskette in the drive number selected. It displays errors in a table similar to the Error Display table.

Motor Start Timing Test

Enter E to select this test. This test prompts you to place a formatted diskette in drive A. The test turns the motor on and off constantly to verify that it is operating correctly. Press ESCAPE key to terminate the test.

EXIT Program

All function programs return to the MFT main menu when finished. Exit MFT by selecting option f., exit program.

Printer Test (PRNTEST)

Select PRNTEST after the REQUEST: prompt from the diagnostic command directory. This command causes the following characters to be displayed on the terminal and to be printed on the printer when the printer is connected.

PRINTER TEST X.X

```
!"#$%&'()*+,-./
0123456789:;<=>?
@ABCDEFGHIJKLMNO
PQRSTUVWXYZ[\]^_
`abcdefghijklmno
pqrstuvwxyz{|}~
```

Memory Test (MEMTEST)

MEMTEST command allows the user to test all but a small portion of system RAM for possible errors. Since the program itself occupies some memory, that portion cannot be tested.

Follow this procedure to run MEMTEST.

1. Insert the diagnostic diskette into drive A.
2. Boot up the system. You will see the diagnostic menu.
3. Type MEMTEST at the REQUEST: prompt to select MEMTEST.

The screen will display the following.

```
ALTOS BOOT MEMORY TEST VERSION X.XX
```

```
VALID TEST MEMORY RANGE (HEX)
```

```
COMMON AREA C000 - FFFF
```

```
BANKS 0-2: 0000 - BFFF; BANK 3: 4000 - BFFF
```

```
SELECT MEMORY BANK TO BE TESTED
```

```
TEST ALL BANKS? (YES=Y: NO=N)
```

```
USER DEFINED TEST PATTERN (Y OR N)
```

```
DEFINE PATTERN:
```

```
TEST ALL MEMORY? (YES=Y,NO=N)
```

```
# OF PASSES TO RUN:
```

```
HALT ON FIRST ERROR? (YES=Y,NO=N)
```

```
SPECIFY MAXIMUM # OF ERRORS ALLOWED:
```

```
RUN ALL FIVE TESTS (YES=Y,NO=N)
```

You will be prompted 4 times to select a memory bank. If you wish to elect only one memory bank, select bank, 0,1,2, or 3, and press [RETURN]. Also press [RETURN] to bypass subsequent memory bank select options. You will now receive the following screen display.

```
STARTING ADDRESS (HEX)?
```

```
ENDING ADDRESS (HEX)?
```

Refer to matrix maps for memory address selections. Memory test range is given in the screen display above. Select the starting and ending addresses and press [RETURN] after each selection.

Memory testing will now begin. The screen will display this prompt as it tests.

```
12345  PASSES -      1      ERRORS -      0
12345  PASSES -      2      ERRORS -      0
```

ALL DONE, WAITING FOR CONSOLE INPUT....
 TYPE L TO GET A LIST OF VALID COMMANDS

TYPE C TO GET CURRENT CONTROL WORD
 TYPE L TO GET LIST OF ALL COMMANDS
 TYPE S TO PRINT TEST SUMMARY
 TYPE R TO RESTART THE TEST
 TYPE P TO RESTART WITHOUT CHANGING ANY PARAMETERS
 TYPE H TO HALT TESTING

If you wish to stop the test without terminating it, and see the results, press S (SUMMARY) on the keyboard and the results will be displayed. Press R (RESTART) on the keyboard if you wish to terminate the test, see the results, and select another memory bank.

Press [SYSTEM,RESET] to return to the diagnostic menu.

Replace any defective memory chips with 64Kx1 dynamic RAM 200 nanosecond access time. The chip you select must support a refresh cycle by performing a RAS only cycle at each of 128 row addresses every 2 milliseconds or 128 cycles. Chips that require 256 refresh cycles cannot be used. 64K RAM chips from Okidata and Motorola have been qualified for use in a Series 5 computer.

HARD DISK TESTS AND FUNCTIONS

Hard Disk Test (HARDS5)

HARDS5 tests computer system hard disks. It consists of 9 tests. To run this test, load the ADX diskette and type HARDS5 after the REQUEST: prompt. The screen displays the following status message.

```
*** Hard Disk (5") Test Facility vX.X ***
Specify Configuration of HARD DISK to be tested.
Default Configuration is:
Drive Number           : 1
Cylinders per Drive    : 153
Number of Heads        : 4
Sector Size            : 512
Press RETURN to bypass a selection.
Enter Drive Number     ("1" or "2")      <CR>
```

Respond by specifying the conditions under which you will run the hard disk tests or functions. The following prompts will appear.

```
Enter cylinders per drive ("1" = 153; "2" = 306) <CR>
Enter Number of Heads ("2", "4", "6", or "8") <CR>
Enter Sector Size ("1" = 256; "2" = 512) <CR>
```

*** Hard Disk (5 1/4") Test Facility vX.X ***

1. Format Disk Drive
2. Verify Addresses for all sectors on Disk
3. Seek Test with optional Verify
4. Write entire Disk
5. Read entire Disk
6. Set Flag Byte for a Specific Sector
7. Hard Disk Read/Write Error Test
8. Miscellaneous Functions
9. Terminate Test.

Select required function by number:

Format Disk Drive

This function formats each sector on the hard disk drive. This function will erase flag byte indications of bad sectors (obtained from the Seagate error map provided with each computer) and all data. Sectors previously marked as bad will now be marked as valid. Unless these sectors are re-marked as bad sectors, data written on these bad sectors will be lost.

```
*****
* WARNING: THIS HARDTEST FUNCTION *
* CHANGES DATA ON THE HARD DISK *
* AND MAY CAUSE LOSS OF USER DATA *
*****
```

Once you have selected test 1 and pressed return, the screen will display the following.

```
*** DO NOT RUN THIS TEST WITHOUT PERMISSION FROM -ALTOS- CUSTOMER
SERVICE *** CALL 408 946 6700
Do you want to continue?
```

This function will destroy user data. Password entry is used as a safeguard to protect the system and the data it stores. You can obtain this password from your distributor or from ALTOS customer service. (Contact your distributor first.)

Before a password is given to you, an attempt will be made to determine whether a format of the hard disk is necessary.

Type your password after the question mark if you wish to continue. If you enter N and press [RETURN], you will return to the hard test selection menu.

Enter your password and press [RETURN]. The screen will display the following.

```
*** THIS TEST WILL ERASE FILES ON THE HARD DISK. ***
Do you want to continue? (Y or N):
```

Type Y and press [RETURN] to continue. The format process will begin and you will see a count from 0 to 152 appear on the screen as each cylinder is formatted. The program returns to the hard disk menu when formatting is completed, and you will be prompted to make a new selection.

REMEMBER: You have formatted the disk, but you have not flagged any bad sectors, nor have you allocated dummy files to those bad sectors. This should be done before any attempt is made to transfer user data to the hard disk.

Verify Addresses for All Sectors on Disk

This test checks addresses on the hard disk. It does not erase user data. It reads every sector on the hard disk and checks the first three bytes. These bytes contain the cylinder, head/drive and sector numbers.

Type 2 [RETURN] to select this test. The screen will display the following.

Press any Key when "ready" to Start this test.

You will see a count displayed at the bottom left corner of the screen as the tracks are checked. Any bad sectors encountered which have been flagged as bad will cause a BAD SECTOR display. Any bad sectors encountered which have not been flagged earlier as bad will possibly cause a CRC error display. Once complete, the screen will display the hard disk test menu again.

You will be prompted to select which hard disk test or function you wish to perform.

Seek Test with Optional Verify

This test seeks between two operator specified cylinders and verifies the addresses at head 0, sector 0, of each specified cylinder.

Type 3 [RETURN] to select this test. The screen displays this prompt.

Press any key when ready to start this test.

The program then prompts you to specify a low cylinder and a high cylinder to set the test boundary. For maximum boundary limit, select cylinder 0 and cylinder 152. For minimum boundary, specify cylinder 0 and cylinder 1. Specify any appropriate low/high cylinder combination.

The program then prompts you to set the verification flag on the test loop. To the operator it doesn't appear to make any difference whether Y or N is selected, the cylinder numbers will be displayed as the seek is performed, but if Y is selected the

logic of the system reads data for each cylinder. With Verification selected a BAD SECTOR display will be generated if any bad sector that has been flagged is encountered. If the head 0 and sector 0 address of the specified cylinder has not been previously flagged as a bad sector, and the I.D. block for that sector is bad, a RECORD NOT FOUND display will be generated. The system may not be performing the seek operation properly. To verify that SEEK is performing properly, select another cylinder.

Write Entire Disk

This function writes a two-byte character to the data block for each track of the disk. This character can be selected by the operator.

Type 4 [RETURN] to select this test. Answer Y at this warning prompt to continue.

WARNING: THIS HARDTEST FUNCTION
CHANGES DATA ON THE HARD DISK
AND MAY CAUSE LOSS OF USER DATA
Do you wish to continue? (Y or N)

The test asks if you want to specify a write-pattern. Enter Y [RETURN] to specify a pattern. You will be prompted to select the pattern you wish to use.

If you have no specific pattern, enter n [RETURN]. The system will then write its own character, E5H, on the disk. You will see the count, track by track, as it writes to the disk.

The final error display can vary depending upon these four write situations.

1. Writing to a flagged bad sector will cause a BAD SECTOR display.
2. Writing to an unflagged bad sector may cause a CRC error display if the ID block and CRC bytes are also bad.
3. Writing to an unflagged bad sector with a bad ID block will generate a RECORD NOT FOUND display regardless of the condition of the CRC portion of that ID block.
4. A bad sector with a bad data block by a good ID block will not generate an error display. A READ test will detect this error condition.

Read Entire Disk

This function reads each sector of each track of the hard disk. The test uses a memory buffer area. The program writes FFH hex into the memory buffer before beginning the read process. As each sector is read into this buffer, the contents of that sector will

be written over the FFH hex number that is located there.

FFH hex is again written to the memory buffer, and the next sector writes over FFH a second time. This "flushing" of the memory buffer is done to ensure that the contents of each sector are read accurately.

Type 5 [RETURN] to select this test. This menu of display options screens.

Hard Disk read display Options are:

1. DO NOT Display data if any error,
2. Display data only if a STATUS error,
3. Display data only if a COMPARE error,
4. Display data if a STATUS or COMPARE error.

Select option by number:

Option Descriptions

1. Option #1 runs the test but does not display on the contents of the data block any status or compare errors.
2. Option #2 will cause the hard disk controller to send back status errors when the controller is unable to locate and properly identify a sector. The data block is passed unchecked but the program will check the CRC portion of the data block for CRC error. This option displays the contents of any error sector found, along with an error message.
3. Option #3 allows the operator to select a one or a two byte character for comparison for the test. It will display the following prompt.

Patterns can be specified by entering:

- *1 - for 256 byte pattern (hex 00 FF)
one or two byte pattern - enter pattern in binary, octal, decimal or hex

Select pattern:

You should select the same read bytes that you used to perform a write test (HARDS5 test #3). This option uses the CPU to compare the contents of the data block against the operator-selected pattern.

A compare error generates an error message along with the contents of the bad sector. Since the data block does have a CRC area associated with it, the sector CRC is also checked. It is possible (but unlikely) that the data could be compared favorably, but the CRC bits be found in error. If this occurs, a CRC ERROR display message will display.

4. Option #4 also allows you to select read-bytes. This option displays both status and compare errors, as well as the contents of the sector found in error.

Set Flag Byte for a Specific Sector

This function may be done in one of two ways:

1. You can use error map data provided by Seagate.
2. You can select the cylinder, head, and sector to be flagged.

Type 6 [RETURN] to select this test. The program displays this warning.

*** THIS TEST WILL ERASE FILES ON THE HARD DISK. ***
Do you want to continue? (Y or N):

Press any key when ready to start this test.

The program then displays this option menu.

Hard Disk "Flag Bad Sector" Options are:

1. Disk Error Map
2. Cylinder, Head, Sector

Make your selection and press [RETURN]. If you select option #1, you will be prompted to enter TRK, HD, byte count and length in bits. Type your selection and press [RETURN].

```
Select option by number: 1
Enter CYL:                60
Enter HD:                 2
Enter SECTOR Number:     4
Enter BYTE Number:       300
Bad sector Range : cylinder = 60 head = 2 sector(s) = 12
```

Do you want to continue this test? (Y or N):

If you type Y at the prompt, the program will continue to prompt you for the next bad sector to be flagged, until all bad sectors have been flagged. If you enter N [RETURN], the program will return you to the hard disk menu.

NOTE

This function sets flags for bad sectors but it does not allocate alternate sectors to those sectors which you have flagged. Run HRDINIT5 to allocate alternate sectors.

Hard Disk Read/Write Error Test

In this test, an error is considered to be a "soft" error when one unsuccessful attempt has been made to read data. A RECAL is made between each attempt. If the READ is successful on the second or third attempt, then the program declares a soft error. The program tolerates a certain number of soft errors.

The program declares a "hard" error after it has made three unsuccessful attempts to read data. The hard error is declared, flagged, and allocated. Sectors containing hard errors should be mapped by using either this test; test #7; or by using the combination of tests #6 and #8.

This test provides two functions:

1. It fully tests all aspects of the disk by writing and reading a variety of data patterns to the entire disk. The display will show all hard errors (bad sectors) and CRC errors.
2. Once the first function is terminated, the user is given the opportunity to allocate dummy files to those bad sectors which were flagged during the first portion of the test.

Press [ESC] to terminate the test. The program will go back and erase the entire disk and automatically flag those sectors which is identified as being bad.

Type 7 [RETURN] to select test #7. The display will inform you that the test will erase files on the hard disk and ask if you want to continue (Y or N). Type Y [RETURN]. The display will then prompt you to press any key when you are ready to start the test.

WARNING; THIS HARDTEST FUNCTION
CHANGES DATA ON THE HARD DISK
AND MAY CAUSE LOSS OF USER DATA
Do you want to continue? (Y or N)

This Error Test Menu displays next.

Hard Disk reliability display Options:

1. Continuous display on terminal.
2. Display error summary at the end of each pass.
3. Display error summary only at the end of the test.

Select option by number

Use Option #1 with the ADM31 and Televideo 912 terminals, and other terminals with similar type cursor control.

Use Option #2 with any terminal.

Use Option #3 when no terminal is attached to the computer system or when the terminal is to be removed during test.

This prompt displays after you have selected your option.

Do you want to display data if a CRC error? (Y or N):

Do you want to write specific patterns? (Y or N):

A "Y" response to the last prompt will generate this pattern prompting menu. Type the pattern you want to write onto the disk and press [RETURN]. The program will shift to the next pattern on the menu. Press [RETURN] alone to accept the pattern showing for the pattern option.

The screen will fill with the display which is used for this test. You will also hear the hard disk chirp as the heads seek the patterns on the disk.

Pattern #1 revisited: E5E5H
 Pattern #2 revisited: 5555H
 Pattern #3 revisited: AAAAH
 Pattern #4 revisited: FFFFH

Press any key when ready to continue this test.

The program displays all patterns, and separates hard errors and soft errors into individual categories. If you have bad sectors on your hard disk you will be able to see the computer record the bad sectors as it encounters them. The counter also increments as it writes from track to track.

This test can take several hours to complete. Set up the test to run overnight, if possible. Press [ESC] to terminate the test. The test will complete its current pass, and stop. It will ask if you wish to print out the test results.

Pass count:
 Pattern:
 Cylinder:

Soft Errors

Chars: E5E5H	CMP Err	0	CRC Err	0	RNF Err	0	BAD SEC	0
Chars: 5555H	CMP Err	0	CRC Err	0	RNF Err	0	BAD SEC	0
Chars: AAAAH	CMP Err	0	CRC Err	0	RNF Err	0	BAD SEC	0
Chars: FFFFH	CMP Err	0	CRC Err	0	RNF Err	0	BAD SEC	0

Hard Errors

Chars: E5E5H	CMP Err	0	CRC Err	0	RNF Err	0	BAD SEC	0
Chars: 5555H	CMP Err	0	CRC Err	0	RNF Err	0	BAD SEC	0
Chars: AAAAH	CMP Err	0	CRC Err	0	RNF Err	0	BAD SEC	0
Chars: FFFFH	CMP Err	0	CRC Err	0	RNF Err	0	BAD SEC	0

Finishing Current Pass

Do You want to print (LP) the errors? (YES=Y,NO=N)

The program will display a soft error table that summarizes the entire test. Press any key on the keyboard to generate a hard error display.

Miscellaneous Functions

At present this selection provides three unique functions:

1. You may alter the way displays are provided on other hard disk tests. Type 1 [RETURN] and the screen will display this prompt.

Do you want the disk error status message displayed? (Y or N)

2. You may display a sector on the screen in ASCII, on the right side of the screen, and in HEX on the left side. Type 2 [RETURN] and the screen will display this menu.

* DISPLAY HARD DISK SECTOR *

Enter Cylinder Number: (Select and press return)

Enter Head Number: (Select and press return)

Enter Sector Number: (Select and press return)

Type 4 [RETURN] to terminate this test. The display will return to the hard disk test menu.



Preliminary Series 5 Computer System Supplement 5. Altos Utility Programs

Revision D
April 23, 1982

Disclaimer

This is a preliminary publication of the Altos Series-5 Computer System Documentation and is presented for information purposes only; it will be changed without notice.

The information contained herein represents the most current information available at the time of printing, however, the information has not been thoroughly reviewed nor has it been approved in its present form. Altos Computer Systems assumes no liability whatever related to use of information presented in this publication.

NOTE

This revision replaces but does not
obsolete previous revisions
of this document.

ALTOS SERIES 5 COMPUTER SYSTEM**SUPPLEMENT 5. ALTOS UTILITY PROGRAMS**

This supplement presents general information related to Altos Utility Programs.

FILE TRANSFER PROGRAM (VERSION 2.5)

The File Transfer Program (FTP) resident on both CP/M and MP/M master distribution diskettes, is used to transfer files between two Altos Computer Systems through an asynchronous serial channel. FTP runs with either the Control Program Monitor (CP/M) or the Multi-Program Monitor (MP/M) Operating System, serving as a useful tool for transferring files between systems with 8 inch hard disks (such as the Altos ACS 8000-10 computers) and systems with 5-1/4 inch hard disks (such as the Altos Series 5 computers). Full error checking and correction is provided through a CRC-16 polynomial.

FTP Version 2.5 corrects the following problems:

1. More than 16 files can now be transferred using FTP under MP/M II.
2. FTP now works correctly with MP/M II V2.1.

The copies of FTP provided on the distribution diskette use the printer port on the Altos computers. The printer ports can be connected to each other with a null modem cable or with two modems. (The null modem cable is a standard RS-232 cable that swaps lines 2 and 3. Such a cable is available from Inmac; part number 270 in the fall '81 catalog.)

NOTE

If you want to re-connect the printer after running FTP, be sure to re-boot the system.

FTP is brought up on both the sending and receiving computers. It does not matter which side is brought up first. Be careful that files transmitted with FTP do not have the Read Only (RO) attribute. If the file is Read Only, FTP will not be able to write it on the receiving side. If an RO file is accidentally received, erase it on the receiving side, change the attribute to Read Write (RW) using the SET command under MP/M II on the sending side, and transfer it again using FTP.

Baud Rates

There are several versions of FTP on the distribution diskette. The only difference between the various versions is the baud rate used for the transfer. The file named FTP.COM is the standard one that uses 9600 baud. The file name of each of the other versions indicates its baud rate. Both the sending and receiving sides must run at the same baud rate.

These slower versions may be used under either CP/M or MP/M:

FTP12 - 1200 bps
FTP24 - 2400 bps

These faster versions only work in CP/M:

FTP48 - 4800 bps
FTP - 9600 bps
FTP31K - 31250 bps - max cable length - 75 feet
FTP41K - 41666 bps - max cable length - 8 feet

Experimentation with 9600 vs. 31250 baud rates has shown that there is very little difference in total transfer time. The experiment has run on floppy disk systems; on hard disk systems, there might be a greater difference.

Experimentation has shown that the maximum baud rate for FTP under MP/M II with one user is 9600. That is, only FTP12, FTP24, FTP48, and FTP (i.e. 9600 baud) work on MP/M II. If more than one user is active, the maximum baud rate could be as low as 1200.

Procedure

The sending side of the transfer is started by the command:

FTP <afn>

where <afn> is an ambiguous file name as described in the CP/M manuals. For example, the command:

FTP *.COM

sends all of the .COM files to the receiving side. Whereas:

FTP FILE.NAM

sends only file FILE.NAM. The sending FTP periodically types an 's' while waiting for the receiver to become active.

The receiving side is started by one of the following commands:

FTP or FTP u:

where 'u' is the drive letter of the destination disk. If no drive letter is specified, the logged disk is the destination disk. The receiving FTP periodically types a 'w' while waiting for the sender to become active. Since the receiving side normally does not exist by itself, enter [CONTROL] C to get back to CP/M.

NOTE

**The File Transfer Program is copyrighted
by the Balcones Computer Corporation.**

Suppressing the MP/M Loader Display

When the MP/M II loader reads the MPM.SYS file, it displays a load map on console #0. In some applications it may be desirable to suppress this display. To suppress the display:

1. Edit the LDRBIOS.ASM file, replacing the console output code with a RET instruction.

```
; Loader BIOS jump vector:
```

```
...  
    jmp     conout  
...
```

```
conout:  
    ret
```

2. Follow the steps provided in the MP/M II System Guide to integrate the new LDRBIOS.HEX into the MPMLDR.COM file.
3. Update the system tracks of the boot disk with the new loader.

Licensed users are granted the right to include these enhancements in MP/M II software. MP/M II is a trademark of Digital Research.

Setting/Resetting the Raw Console I/O Mode

Some application programs may require raw input from the console. Raw input implies that the operating system takes no action on any special characters, such as ↑C.

An application program may place itself into a raw console input mode by executing the following code sequence:

```
MVI C,9CH
CALL XDOS      ; get process descriptor address
LXI D,6
DAD D
MOV A,M
ORI 80H        ; turn 'on' the high order bit of first
MOV M,A        ; character in the process name
...
```

To get out of raw console input mode, execute the following code:

```
...
MVI C,9CH
CALL XDOS      ; get process descriptor address
LXI D,6
DAD D
MOV A,M
ANI 7FH        ; turn 'off' the high order bit of first
MOV M,A        ; character in the process name
...
```

Note: functions 3,4 and 6 place the system into raw console input mode. All other console I/O functions reset the system to normal console input mode.

Raw console input mode can cause problems. In raw mode, all control characters are ignored by the system, so it is impossible to abort a process running in raw console mode. Use Function 11 to return the system to normal console mode. Do this before any Disk I/O functions if in raw console mode to re-enable the ability to abort processes.

MP/M II is a trademark of Digital Research.

Changing PRL File Minimum Buffer Size Requirements

It may be desirable to allocate a larger default buffer for a program such as the editor. You can change the minimum buffer size requirements for PRL files by following the procedure outlined in this application note. The following steps show how to change the minimum buffer size requirements for ED from 4k to 8k bytes:

```
0A>DDT ED.PRL
[MP/M] DDT VERS 1.1
NEXT PC
2300 0100
-S104
0104 00 00
0105 10 20
0106 .
-V2300
0044
-IED.PRL
-W44
-GO
```

Note: bytes 4 and 5 of the PRL header record (relative to the base) contain the low and high order bytes of the minimum buffer size specification.

Licensed users are granted the right to include these enhancements in MP/M II software. MP/M II is a trademark of Digital Research.

Accessing the Internal MP/M II TOD

Some applications may need to access the internal MP/M II time and date fields to set initial values. The following code sequence could be executed at the end of your MP/M XIOS system initialization procedure. It should be placed at the end because the XDOS call to obtain the system data page address has a side effect of enabling interrupts.

...

```
MVI C,9AH
CALL XDOS          ; obtain the system data page address
                  ; *** warning ***
                  ; the XDOS call enables interrupts
```

```
LXI D,00FCH
DAD D              ; hl -> pointer -> TOD
MOV E,M
INX H
MOV D,M           ; de -> TOD
```

...

Note: The assembly language subroutine TODCNV.ASM, distributed on the MP/M II release disk, converts an ASCII string representation of the time and date into MP/M II internal time and date format.

MP/M II is a trademark of Digital Research.

DMA Disk Controllers with Banked Memory Systems

Special care must be taken in bank switched memory systems that have DMA disk controllers. Bank switching must not be allowed during the transfer of data from the disk controller into a target bank. Use the following solutions to avoid potential problems:

1. The DMA from the disk controller can only be made into common memory and then copied from common memory into the desired actual user buffer. This is a reasonable technique in systems where deblocking is required. Sectors that are larger than 128 bytes are placed in a buffer in common memory and then the specified sector is transferred to the target buffer.
2. The following measures must be taken if the DMA is to be made directly into the user buffer (not in common memory):

Prior to each DMA operation, a DMA active flag must be set to true and then reset following the DMA operation:

```
...  
  
MVI  A,FFH  
STA  DMACTVE  
  
;  initiate DMA operation  
  
;  perform flag wait or poll for operation complete  
  
XRA  A  
STA  DMACTVE  
...
```

Another code sequence must be placed in the XIOS select memory procedure to ensure that the bank cannot be switched during a DMA operation:

```
SELMEMORY:  
...  
  
LDA  DMACTVE  
ORA  A  
JZ   OKTOSWITCH      ; jump if not in DMA operation
```

```
; Next, the bank to be switched can be
; compared with the current bank.  If
; it matches, the DMA operation will not be affected.

JZ   OKTOSWITCH      ; no bank change required

; A new bank is specified and a DMA operation is in
; progress.  A busy wait must now be performed to wait
; until the DMA operation is complete.

; *** warning ***

; The selmemory call is made from inside the dispatcher
; therefore interrupts are disabled and nothing must
; be done which could force a dispatch.
```

```
BUSYWAIT:
    IN   DMASTATUSPORT ; This is a "BUSY-WAIT" !
    ANI  DMADONE
    JZ   BUSYWAIT      ; loop until the DMA is complete
```

Then drop into the remaining select memory procedure:

```
OKTOSWITCH:
    ...
    ...

    RET
```

Licensed users are granted the right to include these enhancements in MP/M II software. MP/M II is a trademark of Digital Research.

Using the Send CLI Command XDOS Function

This application note shows you how to use the Send CLI Command XDOS Function. This powerful function can implement a menu driven application program. You should observe the following steps when using the SEND CLI XDOS function.

1. Change the priority of the calling process so that it is higher (actually a lower value) than the TMP.
2. Obtain the console number of the calling process.
3. Assign the console to the Command Line Interpreter.
4. Issue the send CLI command function call.
5. Issue an ATTACH console function to get the console back after the initiated process has terminated.
6. Restore the priority of the calling process to its original value (usually 200).

The following example appears as segments of a menu-driven program named MENU:

```
;
; XDOS Function Equate Table
;
setpriority      equ      145
attachconsole    equ      146
assignconsole    equ      149
sendCLIcommand  equ      150
getconsole       equ      153

MENU:
    ...

    mvi      e,190
    mvi      c,setpriority
    call     BDOS          ; set priority to 190
    mvi      c,getconsole
    call     BDOS          ; get console # in A reg
    sta      AssignPB     ; fill in
    sta      CLIcommand+1 ;          console fields
    lxi      d,AssignPB
    mvi      c,assignconsole
```

```
call   BDOS           ; assign console to CLI
inr    a
jz     cannotassign   ; assign failed
lxi    d,CLIconmand
mvi    c,sendCLIconmand
call   BDOS           ; send CLI command
mvi    c,attachconsole
call   BDOS           ; attach console
mvi    e,200
mvi    c,setpriority
call   BDOS           ; set priority back to 200
...
```

AssignPB:

```
db     $-$           ; console number
db     'cli'         ; name (cli is lower case)
db     0
...
```

CLIconmand:

```
db     0             ; default disk / user code
db     $-$           ; console number
db     this is an ASCII string terminated with a
        null that is exactly as you would run the
        program from the console. e.g.
        'PIP LST:=MYPROG.LST[PT8]',0
...
```

MP/M II is a trademark of Digital Research.

Creating a Submit File from an Applications Program

This application note shows you how to create a submit file from an application program, how to force its execution and, if required, its termination. The example below illustrates the following steps:

1. Obtain the temporary file drive from the System Data Page.
2. Obtain the console number at which the program is executing.
3. Create the \$n\$.SUB file, where "n" is the console number.
4. Set to "on" the appropriate submit flag in the submit flag array contained in the system data page.

```

;
; BDOS / XDOS Function Equate Table
;
closefile      equ      16
searchfirst   equ      17
deletefile    equ      19
makefile      equ      22
getconsole    equ      153
getsysdatadr  equ      154
subflgofst    equ      128
...
...
mvi          c,getsysdatadr
call         BDOS
lxi         d,196          ; temp file drive offset
dad         d
mov         a,m
sta         FCB
mvi         c,getconsole
call        BDOS
sta         console
adi         '0'
sta         FCB+2          ; put console # in fname
lxi         d,FCB
mvi         c,searchfirst
call        BDOS          ; see if file there
inr         a
jz          nofile
lxi         d,FCB
mvi         c,deletefile
call        BDOS          ; delete old version first

```

Terminating a Submit File Job

At times it may be necessary to terminate the operation of a submit job. This can be done only by zeroing a submit flag which is maintained in the SYSTEM DATA PAGE region of memory.

Locating and then zeroing the submit flag for a console can be done as follows:

```

;
; XDOS Function Equate Table
;
getconsole      equ      153
getsysdatadr   equ      154
subflgofst     equ      128

...
...

mvi      c,getconsole
call     BDOS                ; get console #
push     psf                 ; save console #
mvi      c,getsysdatadr
call     BDOS                ; get system data page adr
pop      psf                 ; restore console #
adi      subflgofst
mov      l,a                 ; hl = address of sub. flag
mvi      m,0                 ; zero submit flag

...

```

MP/M II is a trademark of Digital Research.

File Sharing

This application note explains the method by which multiple users can share files using the MP/M II file system.

PROBLEM

Some application programs require files to be open while the program is running (for example, WORDSTAR). Because of the open files, multiple users of the application need to share those files. Under MP/M II, this normally causes problems if the application program is not written to open the file in Read Only mode. The default mode for the open function is locked mode which prevents sharing of files. This is also the mode that files are opened in if they were written for earlier versions of CP/M and MP/M.

SOLUTION

Put any files that are to be shared on USER 0 of the default disk. Using the SET utility, give the files the attributes of SYS (SYSTEM) and RO (READ ONLY). This forces the BDOS to open the file in READ ONLY mode no matter what mode was specified by the open function.

EXAMPLE

```
0A>SET WSMSG.S.COM [SYS,RO]
```

MP/M II is a trademark of Digital Research.

Program Control of the Control-P Switch

Some applications may need to echo console I/O to the printer under program control.

The CONTROL-P flags are kept in an array in the system. The address of the array is at location SYSTEM DATA PAGE + 126.

SETTING CONTROL-P FLAG

```

mvi      c,9ah      ; Get System Data Page address
call     BDOS
lxi      d,126
dad      d          ; add 126 to Sys. Data Page addr.
mov      e,m
inx      h
mov      d,m        ; DE = addr. of CNTRL-P array
push     d
mvi      c,0a4h     ; Get List Number
call     BDOS
mov      e,a
mvi      d,0
pop      h
dad      d
mvi      m,0ffh    ; set CNTRL-P flag
...      ; cons. i/o is echoed from now on

```

CLEARING CONTROL-P FLAG

```

mvi      c,9ah      ; Get System Data Page address
call     BDOS
lxi      d,126
dad      d          ; add 126 to Sys. Data Page addr.
mov      e,m
inx      h
mov      d,m        ; DE = addr. of CNTRL-P array
push     d
mvi      c,0a4h     ; Get List Number
call     BDOS
mov      e,a
mvi      d,0
pop      h
dad      d
mvi      m,0        ; reset CNTRL-P flag
...      ; console i/o echo is now off

```

MP/M II is a trademark of Digital Research.

Cold Boot Startup Job

MP/M II can execute one command upon cold boot. This command may be a SUBMIT, which in effect allows the system to execute not one but any number of commands upon cold boot.

The Startup command must be in a file containing only one command. The command must follow the standard command format.

Note: The name of the file is critical. The name must be \$n\$.SUP, where "n" is the number of the console at which the command will execute.

The \$n\$.SUP can reside on USER 0 of the System drive with a System (SYS) attribute or it can reside on the System drive on the USER number at which the console comes up upon cold boot.

EXAMPLES

\$0\$.SUP	- Startup File
SUBMIT START\$0\$	- Command contained in the Startup File.

MP/M II is a trademark of Digital Research.

SUBMIT Enhancements

SUBMIT has been enhanced to include some new features and facilities. The enhancements are:

INCREASED \$n\$.SUB FILE SIZE

The \$n\$.SUB file originally had a size limitation of one extent (128 lines). Submit file size is now unlimited.

CHANGING THE USER NUMBER

To change the current USER number in SUBMIT, simply include the USER command in the SUBMIT file.

INCLUDE FILES

SUBMIT now has the facility to use INCLUDE FILES. An include file is a standard SUBMIT file that is subject to all the rules and features of a SUBMIT. The format of the INCLUDE command is:

```
$INCLUDE filename parm1 parm2 parm3 ...
```

The file to be included must have the file extension SUB to indicate a SUBMIT file. Parm1, parm2, etc. are standard parameters to SUBMIT.

The INCLUDE facility basically allows nesting of up to four SUBMITS in a SUBMIT command.

EMBEDDED CONTROL CHARACTERS

Control characters can be embedded in a SUBMIT file by preceding the capitalized character with an ASCII up arrow (^). For example to embed a control X, you would type ^X.

Note: The embedded control characters are not interpreted by MP/M II, but may be of use to programs being executed by SUBMIT.

MP/M II is a trademark of Digital Research.

SPOOL Utility Modifications

SPOOL has been modified to return an error message if the file to be spooled is not found. To do this, SPOOL has to have a transient portion (SPOOL.PRL) and a resident portion. The transient portion parses the command tail, opens the file, passes the file to the spool queue (named SPOOLQ), and displays an error message if the open on the file failed. After this, the transient portion of the spooler terminates itself.

If you do not want to use a memory segment to spool a file, simply issue a SPOOLQ command. The disadvantage to this is that error messages are not returned.

SAMPLE COMMANDS TO SPOOL A FILE

SPOOL file1.typ,file2.typ ...

The SPOOL process parses the command tail, checks for errors, and sends the file to the spool queue (SPOOLQ).

SPOOLQ file1.typ,file2.typ ...

The command tail is sent to the spool queue (SPOOLQ) without any error checking or error reporting.

The SPOOL utility sets its priority to 201. This means that most other processes execute ahead of the SPOOLER. In some situations it may be desirable to change the priority the SPOOLER sets for itself. To change the SPOOLER priority, the SPOOL.BRS file must be modified.

```
A>RDT SPOOL.BRS
```

```
...  
-S3B5  
03B5 C9 C8  
03B6 00 .  
-ISPOOL.BRS  
-W14  
-G0  
A>GENSYS
```

Licensed users are granted the right to include these enhancements in MP/M II software. MP/M II is a trademark of Digital Research.

Record Locking/Unlocking

This application note explains and shows how to use MP/M II's record locking/unlocking facilities.

Record locking/unlocking allows multiple processes to share access of one file. Both processes must open the file in UNLOCKED mode to allow record locking/unlocking. A record locked by one process can only be read by another process, but a locked record can be modified by the process that locked the record.

When a record has been locked by another process, the reading of the locked records should be avoided, to prevent reading data that is being updated. To avoid reading an already locked record, the process should try to lock the record, if the lock fails don't read the record, otherwise read the record.

The following code segment illustrates how to lock records.

```

mvi    c,2ch      ;set multi-sector cnt.
mvi    e,#        ;# = num. of sectors
call   bdos      ;l<= # <=16
mvi    c,2ah      ;lock record
lxi    d,fcbl    ;record to be locked
call   bdos

```

The following code segment illustrates how to unlock records.

```

mvi    c,2ch      ;set multi-sector cnt.
mvi    e,#        ;# = num. of sectors
call   bdos      ;l<= # <=16
mvi    c,2bh      ;unlock record
lxi    d,fcbl    ;record to be unlocked
call   bdos
...
fcbl:
db     0,'DATA',A0H,20H,20H,20H,'DAT',0
ds     20
db     10,0,0     ;begining at record 10

```

MP/M II is a trademark of Digital Research.

MP/M IITM V2.0, Application Note 14, 9/14/81

Copyright ©1981 by Digital Research, Inc., Pacific Grove, CA 93955

GENSYS Enhancements

GENSYS has been enhanced to include some new features and facilities. The enhancements are:

AUTOMATIC RESIDENT SYSTEM PROCESS INCLUSION FACILITY

In addition to GENSYS's automatic system generation facility, GENSYS can include in the system all files that have the file type .RSP on the default disk. To automatically include the .RSP files, type GENSYS \$AR. The R option causes the .RSP files to be included. The R option must be used in conjunction with the A option.

Any .RSP files that you don't want to be included must have their file types changed.

ERROR RECOVERY

If GENSYS is running in automatic mode (\$A option) and it encounters an error, GENSYS begins again in manual mode.

MP/M II is a trademark of Digital Research.

Changing the Priority of SPOOL.PRL

The SPOOL utility sets its priority to 201. This means that most other processes execute ahead of the SPOOLER. In some situations it may be desirable to change the priority the SPOOLER sets for itself. To change the SPOOLER priority, modify the SPOOL.PRL file.

NOTE:

If your serial number is between 4-000-00001 and 4-000-00464, MP/M II SPOOL Patch 11 must be installed before attempting to change SPOOL.PRL's default priority.

PROCEDURE:

Make a back-up copy of SPOOL.PRL before using DDT to make the changes shown below.

```
A>REN spool.sav=spool.prl
A>DDT spool.sav
[MP/M II] DDT VERS 2.0
NEXT PC
0980 0100
-S269
0269 C9 c8
026A CD .
-Ispool.prl
-wll
-g0

A>
```

Licensed users are granted the right to include these enhancements in MP/M II V2.0 software. MP/M II and DDT are trademarks of Digital Research.

Changing the Effects of the BACKSPACE and RUBOUT Keys

In MP/M II, the BACKSPACE key, CONTROL H (ASCII 08H), deletes the last character in the command buffer and does a destructive backspace. The cursor backs up and erases the previous character. The RUBOUT key (ASCII 7FH) or DELETE key deletes the last character in the command buffer and echoes it to the screen. The effects of these two keys can be changed.

Procedure for reversing the BACKSPACE and RUBOUT keys:

```
A>ren resbdos.sav=resbdos.spr
A>ddt resbdos.sav
[MP/M II] DDT VERS 2.0
NEXT PC
0f80 0100
-sc0a
0C0A 08 7f
0C0B C2 .
-sc22
0C22 7F 08
0C23 C2 .
-iresbdos.spr
-wld
-g0
```

```
0A>gensys
```

Procedure for Making RUBOUT Equal BACKSPACE:

```
A>ren resbdos.sav=resbdos.spr
A>ddt resbdos.sav
[MP/M II] DDT VERS 2.0
NEXT PC
0f80 0100
-lc26
0C26 MOV A,B
0C27 ORA A
0C28 JZ 09F6
-ac26
0C26 jmp a0e
0C29 .
-bb28,i
-iresbdos.spr
-wld
-g0
```

```
0A>gensys
```

Procedure for Making BACKSPACE Equal RUBOUT:

```
A>ren resbdos.sav=resbdos.spr
A>ddt resbdos.sav
[MP/M II] DDT VERS 2.0
NEXT PC
0f80 0100
-lc0e
0C0E MOV A,B
0C0F ORA A
0C10 JZ 09F6
-ac0e
0C0E jmp a26
0C11 .
-bb10,1
-iresbdos.spr
-wld
-g0

0A>gensys
```

Licensed users are granted the right to include these enhancements in MP/M II software. MP/M II is a trademark of Digital Research.

MP/M IITM Operating System

PROGRAMMER'S GUIDE

MP/M II V2.1 Programming Guidelines

Addendum #3 to the First Printing - 1981
Copyright © 1982 by Digital Research, Inc.
CP/M is a registered trademark of Digital Research
MP/M and MP/M II are trademarks of Digital Research
Compiled January 15, 1982

This guideline provides additional discussion on the information presented in the MP/M IITM Programmer's Guide. In particular, this document emphasizes those areas of MP/M II where restrictions exist that did not exist in version 1 of MP/MTM or versions 1 and 2 of CP/M[®]. The intent is to enable the MP/M II application programmer to avoid potential problems with new software. As a prerequisite, the reader should be familiar with the material presented in the MP/M II Programmer's Guide.

- 1) Always use the following sequence when performing file operations that require an open file. Under MP/M II, these operations are the BDOS read, write, lock and unlock record commands.
 - Activate a file's FCB with a BDOS Open or Make function call before using the FCB in a file operation. Verify that the Open or Make operation was successful. MP/M II only accepts FCBs activated by a successful Open or Make call for open file operations. If an FCB that has not been activated is used, MP/M II returns a checksum error.
 - Perform all file operations using activated FCBs. Note that MP/M II does not deactivate an activated FCB when it returns error codes for file operations. In general, only the current record and random record fields of an activated FCB should be modified. In addition, all file operations with an activated FCB must be made under the user number that was in effect when the FCB was activated. A similar restriction applies to activated FCBs that specify the default drive. All file operations specifying such an FCB must be made under the current drive that was in effect when the FCB was activated. The complete rules regarding activated FCB modification are covered in item 3.

- If a process has completed file operations on a file but still has a significant amount of processing left to do, the file should be closed. This applies even if the file was not modified. With some exceptions (See Section 2.2.9 of the MP/M II Programmer's Guide), the lock list entry associated with a file in the system lock list is not released until a file is permanently closed. MP/M II restricts access to a file by other processes while a lock list item for the file resides in the system lock list. It is not necessary to close input files if a process is about to terminate. At termination, all lock items belonging to a process are released. Output files, however, must always be closed or data may be lost. Note that a successful permanent close operation deactivates the FCB and removes the file's item from the system lock list. If the deactivated FCB is used in a subsequent open file operation, MP/M II returns a checksum error.
- 2) If a process opens the same file more than once, a matching number of close commands must be issued to the file to remove the file's lock list item from the system lock list. Thus, if a file has been opened N times, the first N-1 close operations issued to the file default to partial close operations. Only the last close, close operation N, is interpreted as a permanent close. By definition, a permanent close is a close operation that removes the referenced file's item from the system lock list. Note that only one lock list item is allocated in the system lock list for a file regardless of the number of FCBs a process has opened for the file.
 - 3) The following list specifies how an activated FCB can be changed without affecting the FCB checksum. MP/M II returns a checksum error code and does not perform the requested operation if an FCB with an invalid checksum is used in an open file operation.
 - FCB(0) cannot specify a new drive.
 - With the exception of interface attributes F5' and F6' for the BDOS Close function, FCB(1) through FCB(11) cannot be changed.
 - The high order 3 bits of FCB(12) cannot be changed. The low order 5 bits can be changed. Note that when a file is opened in the default open mode (locked mode), the high order 3 bits of this FCB field are set to zeros.
 - FCB(13) cannot be changed.
 - FCB(14) and FCB(15) can be changed.
 - FCB(16) through FCB(31) cannot be changed.

- o FCB(32) through FCB(35) can be changed.

If compatibility with future releases of MP/M and CP/M is a requirement, programs should restrict open FCB modification to the FCB fields 32 through 35. In particular, Digital Research does not support techniques that involve modifying fields 12, 14 and 15 of open FCBs.

- 4) Processes that access a printer must issue a Detach List device to free the printer before another process can use the printer. If the Detach List call is not made, a process that accesses a printer continues to own the printer until it terminates.
- 5) CP/M programs that create submit files for chaining must be modified to work under MP/M II. MP/M II requires a different filename for submit files, which includes the originating console number, and requires that a submit flag be set in the System Data Page. The technique for creating and executing submit files is described in MP/M II Application Note 07. Note that MP/M II also has a Program Chain (Function 47) command that provides an efficient mechanism for program chaining.
- 6) CP/M programs that make direct BIOS calls for disk I/O do not work under MP/M II. MP/M II does support direct XIOS calls for the console and printer, but not to the disk. If programs must make direct XIOS disk calls, a technique **strongly** discouraged in a multi-user environment, two levels of indirection must be used to obtain the real XIOS jump table address. The second level of indirection is required because an intercept table handles the console and printer.

The following two steps should be performed in a program before making direct XIOS calls to a disk. The first step is to make a BDOS Write Protect Disk (Function 28) call to the disk to ensure that no other process has open files on the disk. Secondly, the MXDisk mutual exclusion queue message should be read to prevent other programs from making BDOS disk function calls while your program is making direct XIOS calls. After completing your direct XIOS calls, write back the MXDisk message and then reset the drives you have set to Read/Only.

- 7) The following procedure is a protocol that multiple processes can use to coordinate record update and addition operations to a shared file. Each process must open the shared file in unlocked mode. This procedure also assumes that records containing binary zeros are null records.

- Attempt to lock the record.
 - If the lock attempt fails because another process has locked the record, delay and repeat the procedure.
 - If the lock attempt fails because the record does not exist in the file, add a record initialized to binary zeros to the file with the BDOS Write Random with Zero Fill command and repeat the procedure. Note that files opened in unlocked mode are extended in block units and not in record units as is the case for files opened in the default locked mode.
 - If the lock attempt succeeds, read the record, update it, and then unlock it.
- 8) Multiple FCB I/O is a technique that involves opening each extent for a file independently and maintaining them in a table in memory. Then random I/O is handled by selecting the proper FCB from the table, setting the current record field to the proper record number within the extent, and making a sequential Read or Write command. When processing is completed, each FCB is closed. The maximum file size that can be accessed with this technique is 512K bytes. This limits the maximum table size to 32 FCBs. Note that this technique provides a method of performing random I/O that is compatible with CP/M 1.4.

Multiple FCB I/O has to be performed carefully under MP/M II because of the restrictions MP/M II places on file operations to provide file security. In general, an FCB should not be used in file I/O unless it has been activated and it should not be modified while it is activated (see items 1 and 3). In addition, the number of opens and closes issued to a file is important (see item 2). Note that all 32 bytes of each extent's FCB should be maintained in the open FCB table. In addition, verify that interface attribute F8' is set to 1 in all FCBs if the first FCB has F8' set to 1. F8' set to 1 indicates the file was opened under user 0 although the current user number is non-zero (see Function 15 in the MP/M II Programmer's Guide).

MP/M IITM Operating System

PROGRAMMER'S GUIDE

MP/M II V2.1 Extended File Locking

Addendum #2 to the First Printing - 1981
Copyright © 1982 by Digital Research, Inc.
MP/M II is a trademark of Digital Research
Compiled January 15, 1982

Extended file locking is a new facility implemented in release 2.1 of MP/M IITM. Extended file locking enables a process to maintain a lock on a file even after the file is closed. This facility allows a process to rename, set the attributes, or delete a file without having to contend with the possibility of interference from other processes after the file is closed. In addition, a process can reopen a file with an extended lock and continue normal file processing. For example, a process can open a file, perform file operations on the file, close the file, rename the file, reopen the file under its new name, and proceed with file operations, without ever losing the file's lock list item and control over the file.

Extended file locking is only available to files that are opened in the default open mode (locked mode). To extend a file's lock, set interface attribute F6' when closing the file. Note that this attribute is only interrogated by the Close function when it is closing a file permanently. Thus, interface attribute F5' must be reset when the close call is made. In addition, if a file has been opened N times (more than once), this attribute is only interrogated when the file is closed for the Nth time.

To maintain an extended file lock through a Rename File call or a Set File Attributes call, set interface attribute F5' of the referenced FCB when making the call. Note that this attribute is only honored for extended file locks, not normal locks. Setting attribute F5' also maintains an extended file lock for the Delete File function, but setting this attribute also changes the nature of the Delete function to an XFCB-Only delete. If successful, all three of these functions delete a file's extended lock item when with attribute F5' reset. On the other hand, if they return with an error code, the extended lock item is not deleted.

A standard open call can be made to resume file operations on a file with an extended lock. The open mode, however, is restricted to the default locked mode. The following list illustrates uses of extended locks.

- Open file EXLOCK.TST in locked mode
- Perform file operations on the file EXLOCK.TST using the open FCB.
- Close file EXLOCK.TST with interface attribute F6' set to retain the file's lock item.
- Use the Rename File function to change the name of the file to EXLOCK.NEW with interface attribute F5' set to retain the file's extended lock item.
- Open the file EXLOCK.NEW in locked mode.
- Perform file operations on the file EXLOCK.NEW using the opened FCB.
- Close file EXLOCK.NEW with interface attribute F6' set to retain the file's lock item.
- Set the Read/Only attribute and release the file's lock item by using the Set File Attributes function with interface attribute F5' reset. At this point, the file EXLOCK.NEW becomes available for access by another process.

MP/M II[™] Operating System

PROGRAMMER'S GUIDE

MP/M II V2.1 Compatibility Attributes

Addendum #1 to the First Printing - 1981
Copyright © 1982 by Digital Research, Inc.
CP/M is a registered trademark of Digital Research
MP/M and MP/M II are trademarks of Digital Research
Compiled February 4, 1982

The MP/M II[™] file system introduced some new restrictions relating to file operations that were not present in MP/M[™] 1.1 or CP/M[®]. For example, if a process opens a file in the default mode (locked), MP/M II does not allow other processes on the system to open, delete, or rename the file until the process opening the file either closes the file or terminates. In addition, MP/M II does not allow a process to perform file operations with an FCB that has not been activated by a successful open or make operation, or with an FCB that has been deactivated by a close operation. These restrictions protect an MP/M II user from interference from other users on his open files. To illustrate, it is this protection that enables an MP/M II user to edit a file with the assurance that another user cannot delete or modify his file during his edit session.

The new restrictions added to MP/M II were required to provide file security when multiple users are running the system. The above example describes restrictions required to prevent collisions on file activity between independent processes. Another new MP/M II restriction sets limits on how a process can modify open FCBs. These limits are enforced by checksum verification of open FCBs and protect the integrity of the MP/M II file system from corrupted FCBs. Note that the new MP/M II restrictions are not intended to protect a user from his own actions. Instead, they ensure that the activity of one user does not adversely affect other users on the system.

In general, the new MP/M II file system restrictions create little difficulty for new application development. In fact, they enforce what is generally accepted as good programming practice. However, because of these new restrictions, some CP/M and MP/M software written prior to MP/M II's release does not run on MP/M II. In addition, multiple copies of some software do not run because the default open mode for MP/M II is a locked mode in which only one process can open a file.

To address these problems, Digital Research has added compatibility attributes to MP/M II, Version 2.1. The compatibility attributes are defined as attributes F1' through F4' of program

All Information Presented Here is Proprietary to Digital Research

files. A new GENSYS option determines whether the attributes are to be activated. If activated, the Command Line Interpreter (CLI) interrogates these attributes during program loading and modifies the MP/M II ground rules for the loaded program as described below. Note that the compatibility attributes should not be used with new software. They are intended for use with working software developed for CP/M and MP/M 1.1. This especially applies to compatibility attribute F4' which disables FCB checksum verification on read and write operations. Use this attribute sparingly and only with programs that are known to work.

COMPATIBILITY ATTRIBUTE DEFINITIONS

- F1'** MP/M 1.1 Default Open. Processes running with this attribute have all files opened in locked mode marked as Read/Only in the System Lock List. This allows all processes with this attribute set to read and write to common files with no restrictions. There is, however, no record locking provided. In addition, this attribute also allows a process to write to a file opened by another process in Read/Only mode. To be safe, all static files such as program and help files should be made Read/Only when this compatibility attribute is used.
- F2'** Partial Close default. Processes running with this attribute have their default close mode changed from permanent close to partial close. This attribute is intended for programs that close a file to update the directory but continue to use the file. Note that MP/M II assumes a process has finished with a file when the number of closes issued to the file equals the number of opens. A side effect of this attribute is that files opened by a process are not released until the process terminates. It might be necessary to set the System Lock List parameters to high values when using this attribute.
- F3'** Ignore Close Checksum Errors. This attribute changes the way Close Checksum errors are handled for a process. Normally, a message is printed on the console and the process is terminated. When this attribute is set and a checksum error is detected during a close operation, the file is closed if a lock list item exists for the file. Otherwise, an unsuccessful close error code is returned to the calling process.
- F4'** Disable FCB Checksum verification for read and write operations. Setting this attribute also sets attributes F2' and F3'. This attribute should be used carefully because it effectively disables MP/M II's file security. Use this attribute only with software that is known to work.

PROCEDURE FOR USING THE COMPATIBILITY ATTRIBUTES

- 1) Answer yes to the GENSYS question "Enable Compatibility Attributes (N) ?".
- 2) Use the MP/M II Utility SET to set the desired combination of compatibility attributes in the program name.

EXAMPLES:

```
0A>SET filespec [F1=on]
0A>SET filespec [F1=on,F3=on]
0A>SET filespec [F4=on]
```

If you have a program that runs under CP/M or MP/M 1.1 but does not run properly under MP/M II, use the following guidelines to select the compatibility attributes to set for the program.

- 1) If the program terminates with the message, "File Currently Opened" when multiple copies of the program are run, set compatibility attribute F1'. As an alternative, you might consider placing all common static files under User 0 with the SYS and R/O attributes set.
- 2) If the program terminates with the message, "Close Checksum Error", set compatibility attribute F3'.
- 3) If the program terminates with an I/O error, try running the program with attribute F2' set. If the problem still occurs, try attributes F2' and F3'. If the problem still persists, then try attribute F4'. Use attribute F4' only as a last resort.

It might be necessary to increase the GENSYS parameters that set the maximum number of files a process can open and the size of the System Lock List when using compatibility attributes F2' and F4'. This might be required because both default to partial closes. As a result, system lock list entries consumed by opening files are not released until the process terminates. In general, if a process terminates with the message "No Room in System Lock List" or "Open File Limit Exceeded", it usually indicates that the above GENSYS parameters need to be increased. Another option is to patch in a BDOS Free Drive call at a point in the program where no files are active. Note that a Free Drive call specifying all drives, purges all file system lock entries belonging to the calling process.

When GENSYS activates compatibility attributes, the Command Line Interpreter copies the settings for attributes F1' through F4' of the filename of the loaded program into byte 1DH of the process descriptor as shown below:

PROCESS DESCRIPTOR BYTE 1DH

(Bits defined 7-0 high order to low order)

Bit 7 set = F1
Bit 6 set = F2
Bit 5 set = F3
Bit 4 set = F4

RMAC™ 1.1 Application Note 01, 6/19/81

©Copyright 1981 by Digital Research, Inc., Pacific Grove, CA 93950

INCLUDING LOCAL SYMBOLS

Products: PL/I-80™ 1.3 and RMAC™ LINK-80™ LIB-80™

This application note shows how to patch RMAC so that local symbols as well as publics are put into the object file produced by RMAC, and hence into the SYM file produced by LINK.

```
A>ddt rmac.com
DDT VERS 2.2
NEXT PC
3600 0100
-s1167
1167 08 18
1168 32 .
-g0
A>save 53 rmac.com
A>
```

Licensed users are granted the right to include these changes in RMAC software. LINK-80, LIB-80, PL/I-80 and RMAC are trademarks of Digital Research.

RMAC™ 1.1 Application Note 01, 6/19/81

©Copyright 1981 by Digital Research, Inc., Pacific Grove, CA 93950

INCLUDING LOCAL SYMBOLS

Products: PL/I-80™ 1.3 and RMAC™ LINK-80™ LIB-80™

This application note shows how to patch RMAC so that local symbols as well as public symbols are put into the object file produced by RMAC, and hence into the SYM file produced by LINK.

```
A>ddt rmac.com
DDT VERS 2.2
NEXT PC
3600 0100
-s1167
1167 08 18
1168 32 .
-g0
A>save 53 rmac.com
A>
```

Licensed users are granted the right to include these changes in RMAC software. LINK-80, LIB-80, PL/I-80 and RMAC are trademarks of Digital Research.

APPENDIX A

MATRIX MAPS

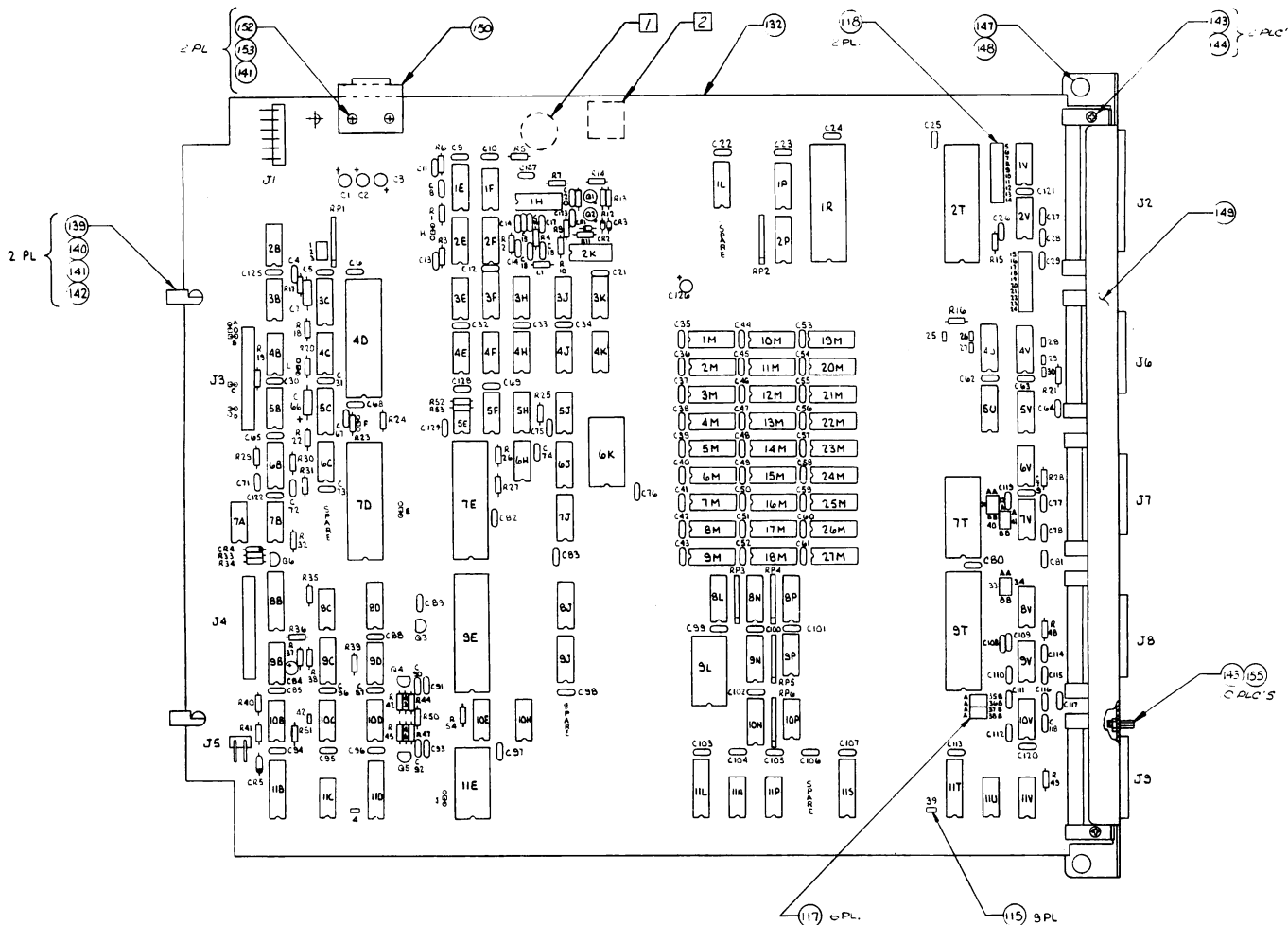

Figure A-1. Z80 Mini Computer PCB Matrix Map

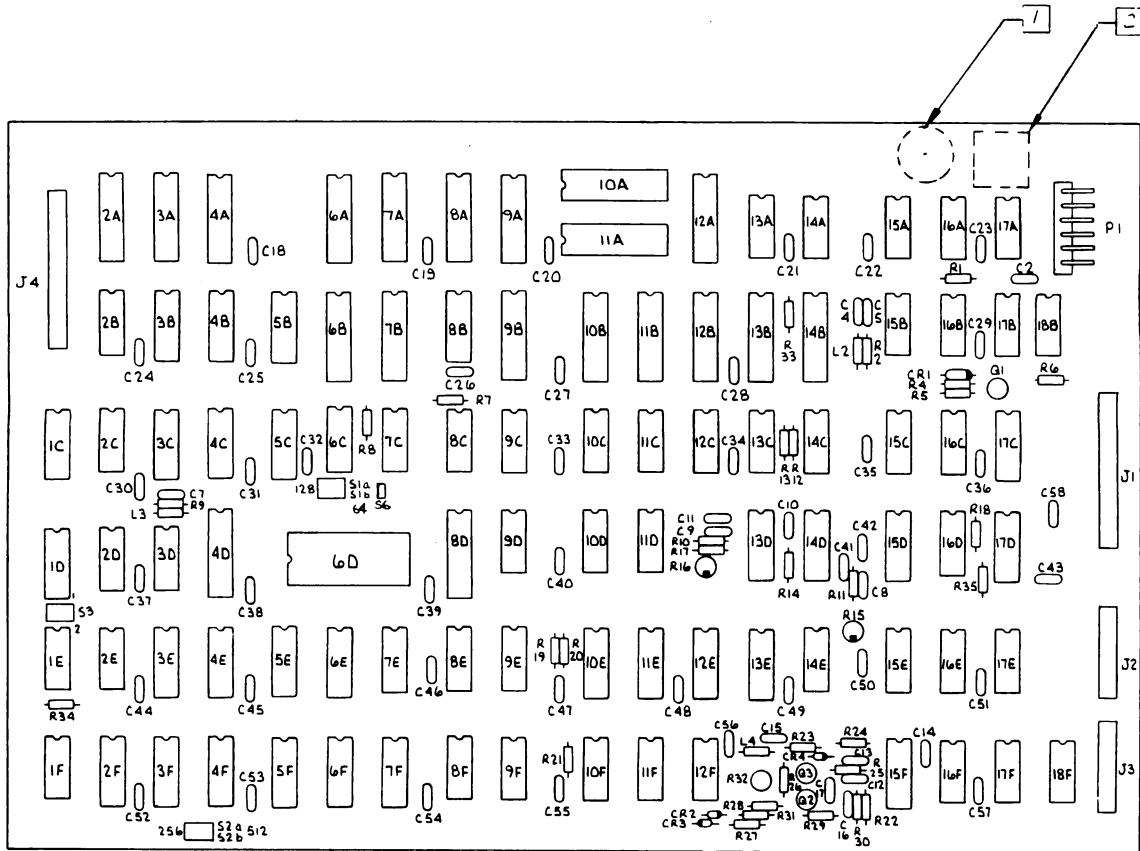
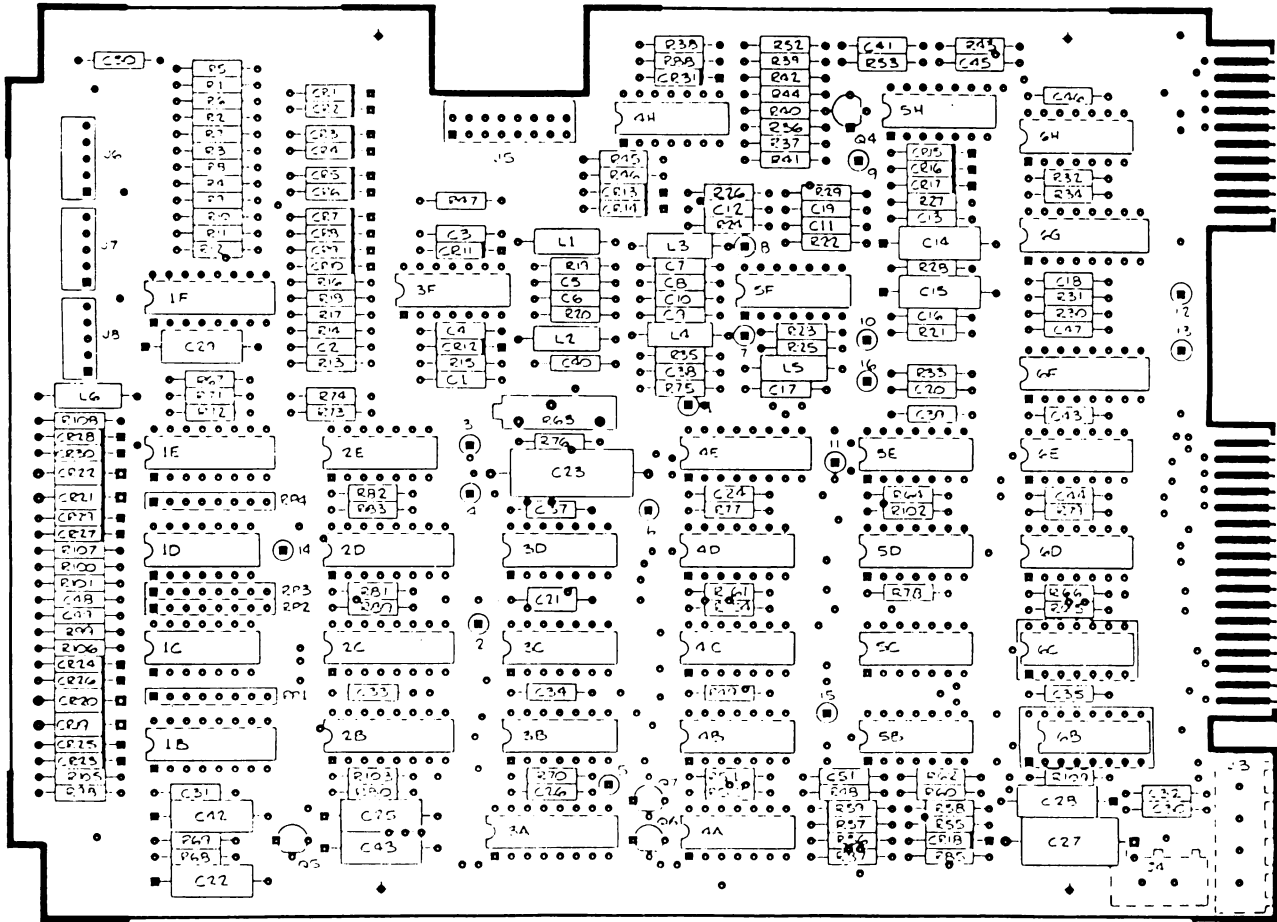
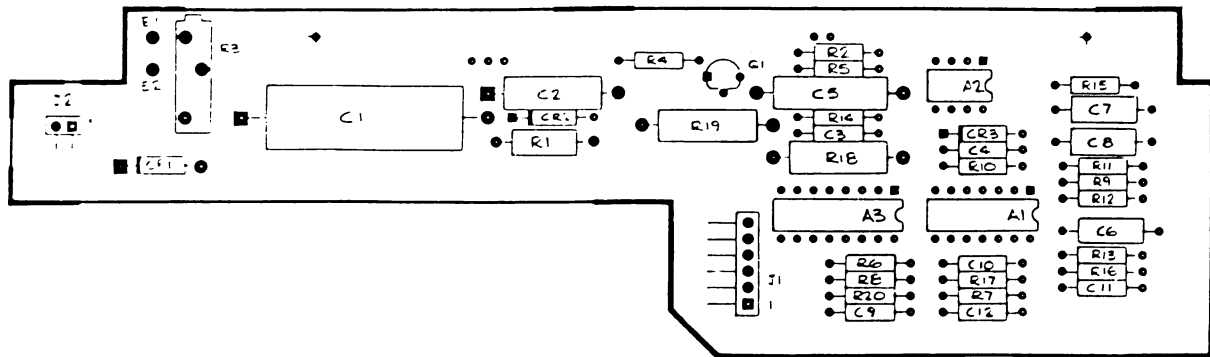

Figure A-2. 5-1/4 Inch Hard Disk Controller PCB Matrix Map



MAIN CONTROL P.C.B. P/N 20040



MOTOR CONTROL P.C.B. P/N 20003

Figure A-3. Seagate Hard Disk Drive PCB Matrix Map

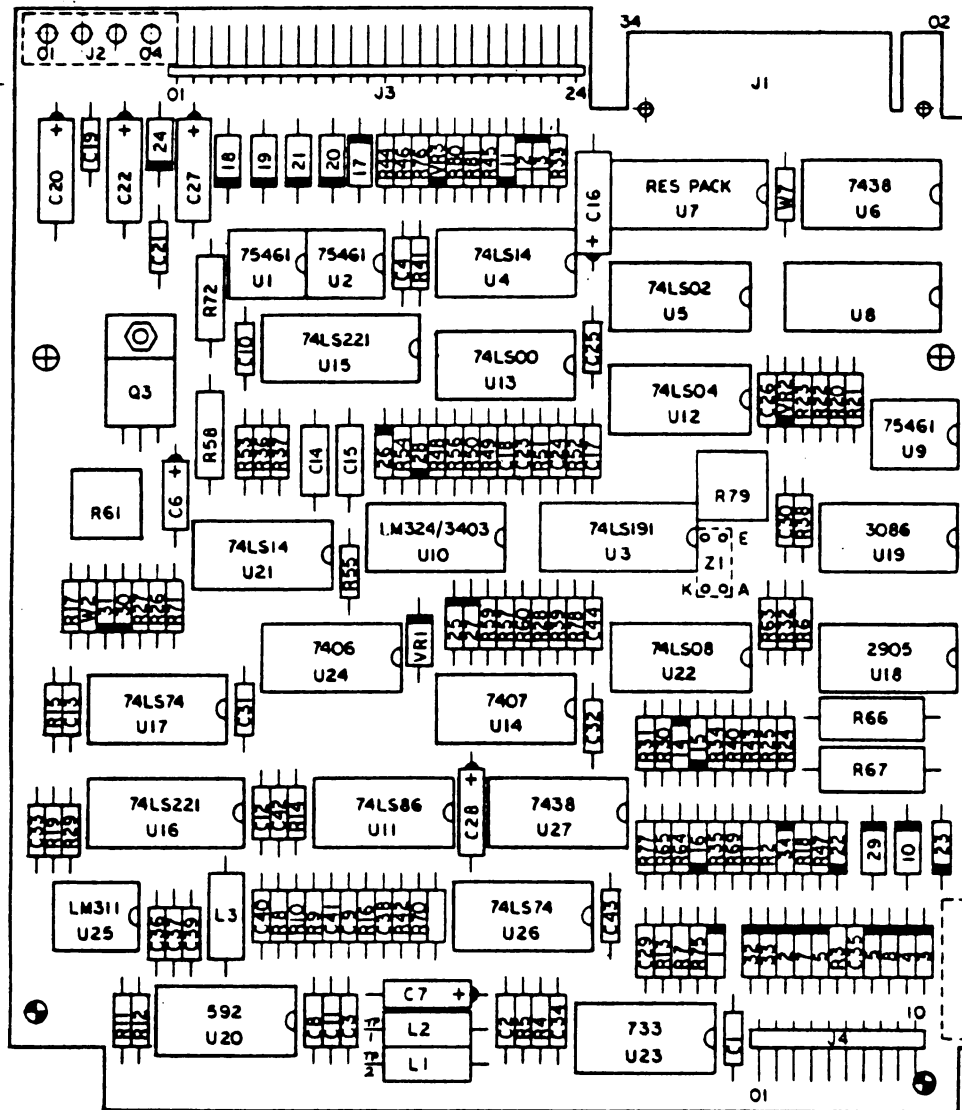

TRANSISTORS

Q3 - T1P120

DIODES

CR1, CR2, CR3, CR4, CR5, CR6, CR7, CR8,
CR11, CR12, CR13, CR14, CR15, CR16,
CR22, CR23, CR25, CR26, CR27
CR28, CR30, CR31, CR32, CR33, CR34

1N914B

CR9, CR10, CR17, CR18, CR19, CR20,
CR21, CR24, CR29

1N4001

VOLTAGE REGULATORS

VR1, VR3 - DIODE ZENER 7.5 V
VR2 - VOLT REG 5% 2.4 V

GG235

Figure A-4. CDC Floppy Disk Drive PCB Matrix Map

APPENDIX B

SCHEMATICS

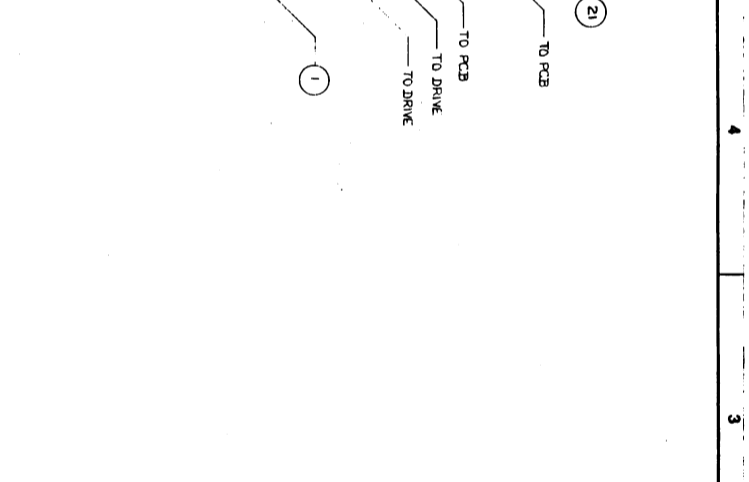
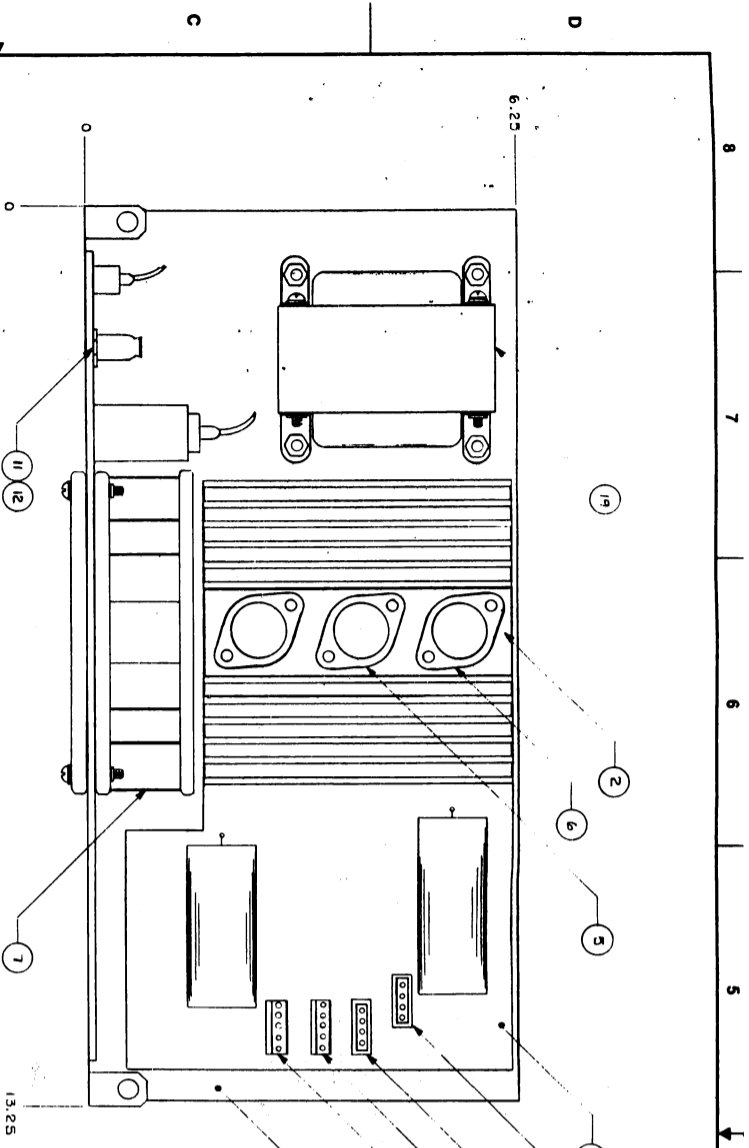

NOTES: UNLESS OTHERWISE SPECIFIED
 1. FOR SPECIFICATION OF ASSEMBLED POWER SUPPLY SEE KENTEC PARTS LIST NO. 6128-301 REFERENCE BELOW
 2. FOR SCHEMATICS SEE SHEET 2.

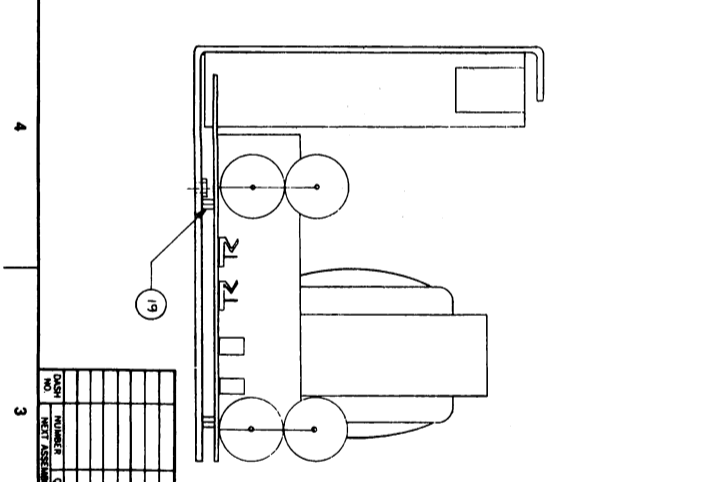
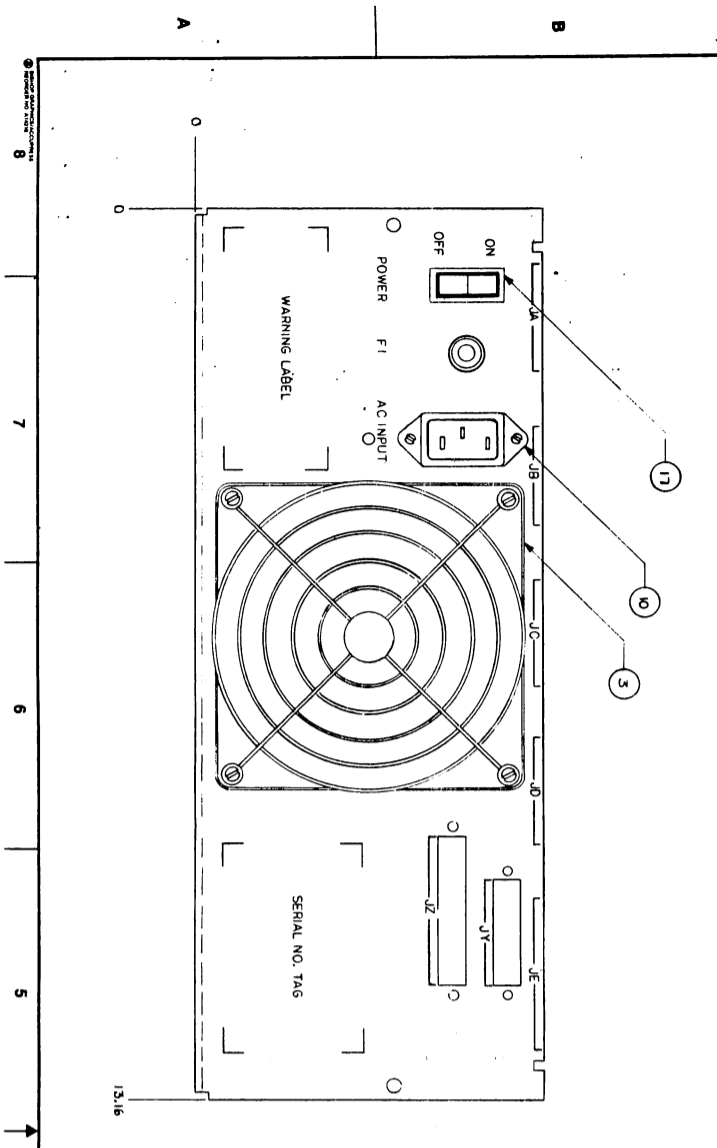

REF	QTY	DESCRIPTION	UNIT	ITEM
REF 6128-304	1	KENTEC P/N CLASSIS SILKSCREEN		22
REF 6128-302	1	KENTEC P/N REG BOARD ASSY		21
REF 6128-101	1	KENTEC P/N WIRE LIST PWR SUPPLY		20
1	1	6128-101 KENTEC P/N TRANSFORMER		19
1	1	1-208140-0 KENTEC P/N BRIDGE		18
1	1	6-400002-1 KENTEC P/N SWITCH		17
6	1	6-620001-1 KENTEC P/N PH		16
1	1	1-610610-0 KENTEC P/N CONNECTOR		15
6	1	6-620002-1 KENTEC P/N PH		14
1	1	1-610706-1 KENTEC P/N PH		13
1	1	1-800200-0 KENTEC P/N CONNECTOR		12
1	1	1-7000-0 KENTEC P/N FUSE HOLDER		11
1	1	1-150002-0 KENTEC P/N FUSE 2A		10
2	2	2-51000-1 KENTEC P/N FILTER / CONDM		9
3	3	3-51000-1 KENTEC P/N SPACER BRASS 8-32 X 1/4		8
1	1	1-100002-0 KENTEC P/N PAN / ROTROM		7
1	1	8-203771-0 KENTEC P/N PAN / ROTROM		6
1	1	8-203771-0 KENTEC P/N TRANSDUCER		5
1	1	8-203035-0 KENTEC P/N TRANSDUCER		4
1	1	1-100004-0 KENTEC P/N PAN COND 12"		3
1	1	1-100003-0 KENTEC P/N FINGERGUARD/ROTROM		2
1	1	1-100002-0 KENTEC P/N HEAT SINK		1

DATE	BY	DESCRIPTION
11-5-73	J.F.	ASSEMBLED
11-5-73	J.F.	DESIGNED

TITLE: ALTO 8 COMPUTER SYSTEMS
 SERIES: 5
 SCALE: D
 PART NUMBER: 430-11069-001
 CODE: A
 SHEET 1 OF 2

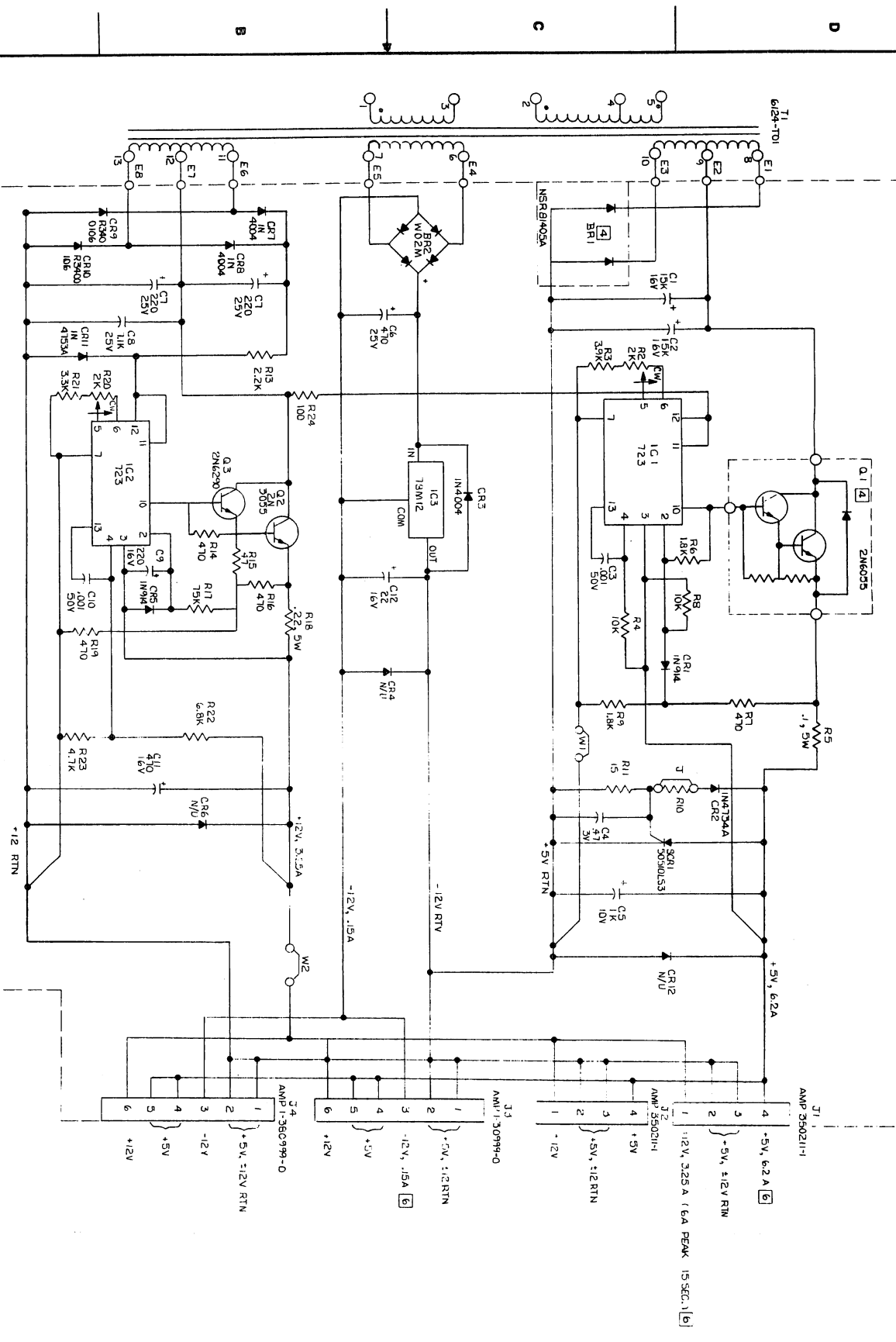

JUMPER CHART

AC	JUMPER	APPLY AC
100	1-2, 3-4	1, 5
115	1-2, 3-4	1, 4
215	2-3	1, 5
230	2-3	1, 4

- NOTES: UNLESS OTHERWISE SPECIFIED
1. ALL RESISTANCE VALUE IN OHMS, ±2%, 1/8 W.
 2. ALL CAPACITANCE VALUE IN MICROFARADS.
 3. COMPONENTS MOUNTED ON CHASSIS.
 4. COMPONENTS MOUNTED ON HEATSHINK.
 5. REF. DOCUMENTS : XENITEC PARTNLS. 6124-201, B102.
 6. TOTAL CURRENT SUPPLIED BY ALL CONNECTORS.

REV	DATE	DESCRIPTION	BY
1			
2			
3			

REV	DATE	DESCRIPTION	BY
1			
2			
3			

REV	DATE	DESCRIPTION	BY
1			
2			
3			

REV	DATE	DESCRIPTION	BY
1			
2			
3			

REV	DATE	DESCRIPTION	BY
1			
2			
3			

REV	DATE	DESCRIPTION	BY
1			
2			
3			

REV	DATE	DESCRIPTION	BY
1			
2			
3			

REV	DATE	DESCRIPTION	BY
1			
2			
3			

REV	DATE	DESCRIPTION	BY
1			
2			
3			

REV	DATE	DESCRIPTION	BY
1			
2			
3			

ZONE	REV	DESCRIPTION	DATE	APP'D
A	REV FOR PROO	EQ # 005/1	1-3-62	SK
B	REVISED PER EQ 00085		2-22-62	SK
			2-16-62	SK
			2-16-62	SK

REV	DESCRIPTION	DATE	APP'D
1			
2			
3			
4			
5			
6			
7			
8			
9			
10			
11			
12			
13			
14			
15			
16			
17			
18			
19			
20			
21			
22			
23			
24			
25			
26			
27			
28			
29			
30			
31			
32			
33			
34			
35			
36			
37			
38			
39			
40			

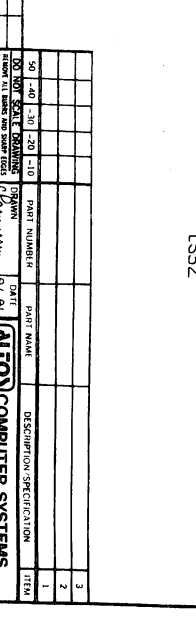
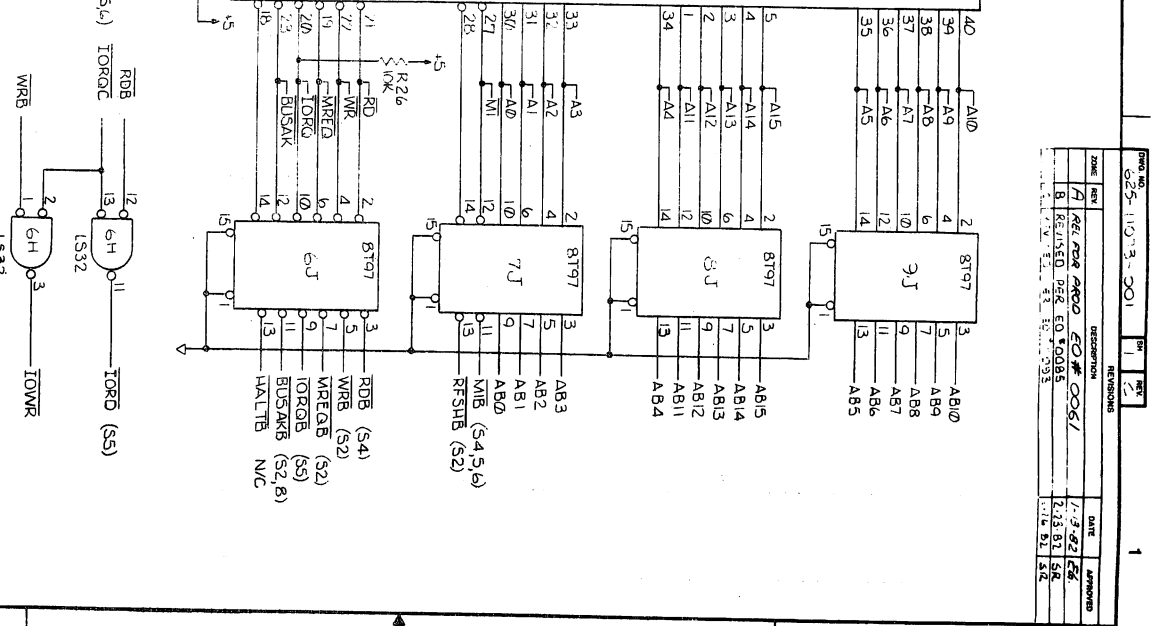
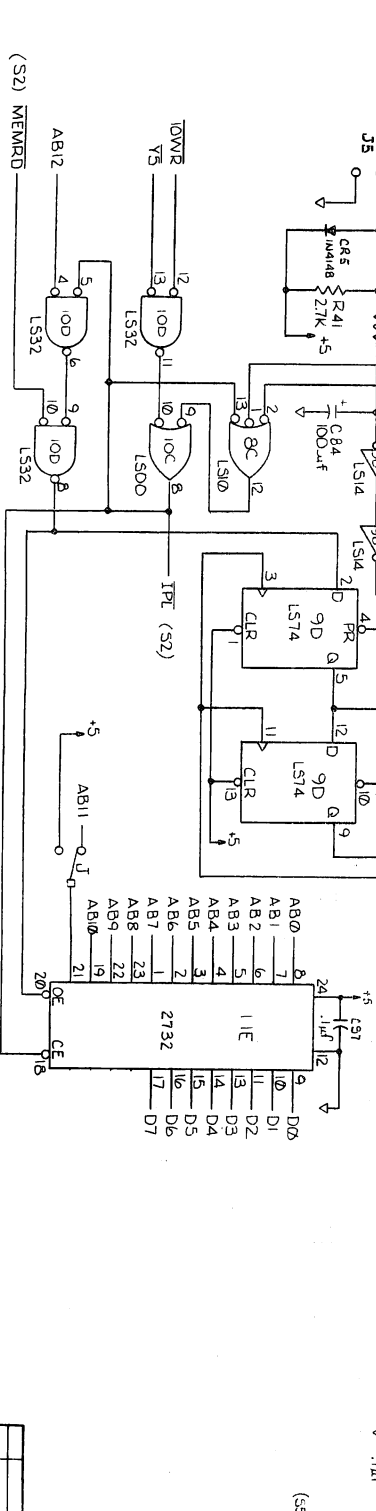
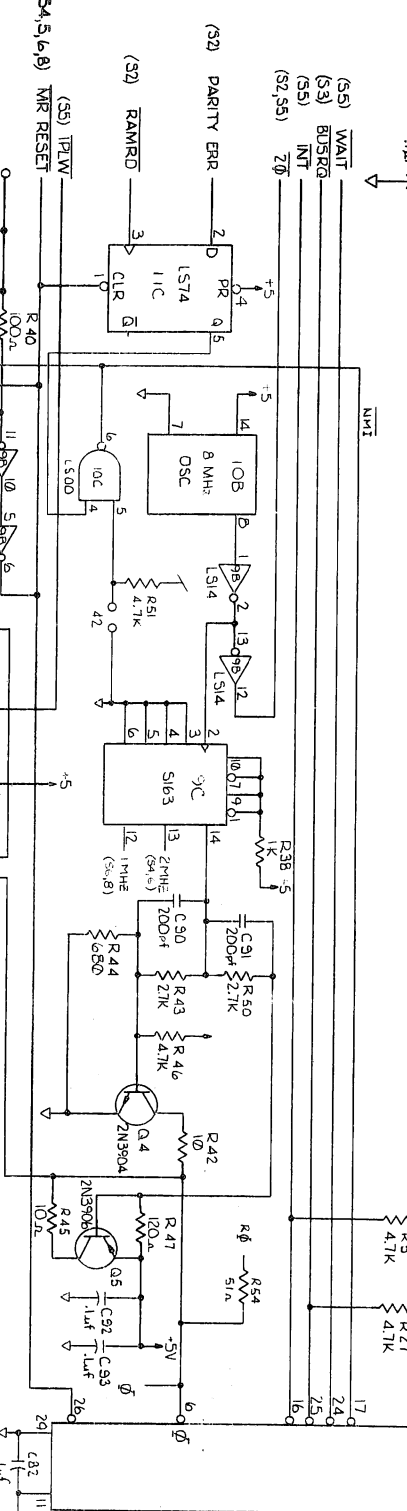
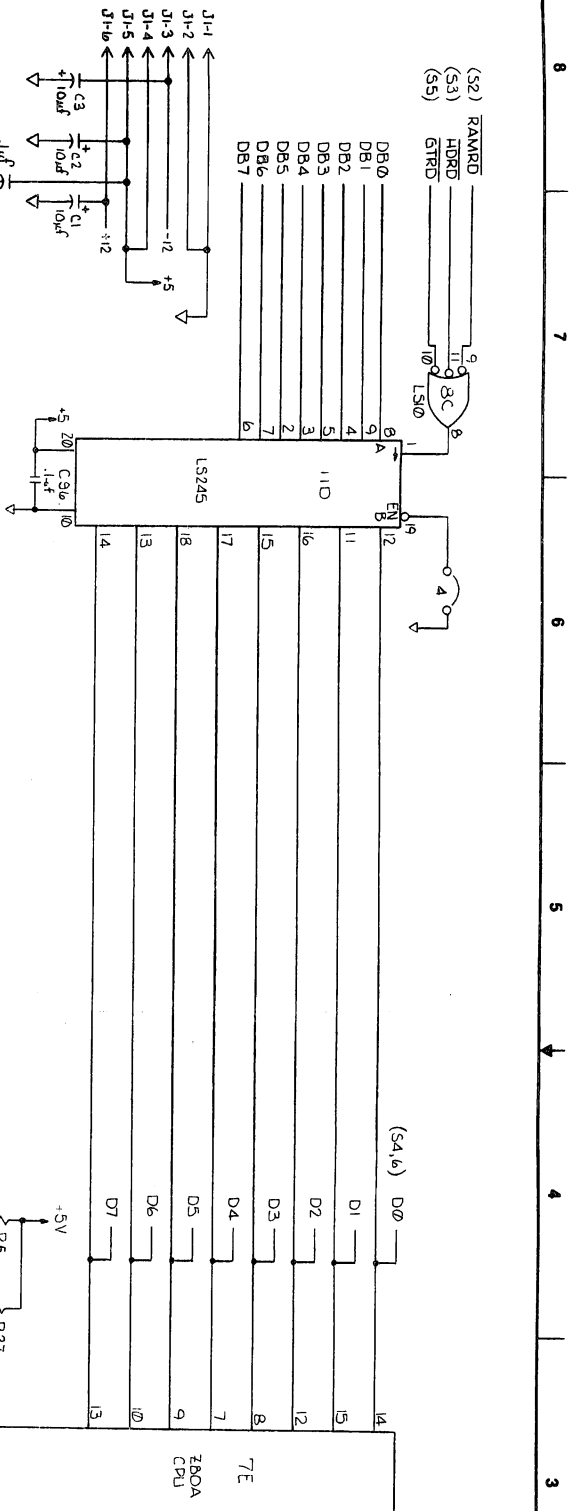

REV	DESCRIPTION	DATE	APP'D
1			
2			
3			
4			
5			
6			
7			

REV	DESCRIPTION	DATE	APP'D
1			
2			
3			
4			
5			
6			
7			

REV	DESCRIPTION	DATE	APP'D
1			
2			
3			
4			
5			
6			
7			

REV	DESCRIPTION	DATE	APP'D
1			
2			
3			
4			
5			
6			
7			

REV	DESCRIPTION	DATE	APP'D
1			
2			
3			
4			
5			
6			
7			

REV	DESCRIPTION	DATE	APP'D
1			
2			
3			
4			
5			
6			
7			

REV	DESCRIPTION	DATE	APP'D
1			
2			
3			
4			
5			
6			
7			

REV	DESCRIPTION	DATE	APP'D
1			
2			
3			
4			
5			
6			
7			

REV	DESCRIPTION	DATE	APP'D
1			
2			
3			
4			
5			
6			
7			

REV	DESCRIPTION	DATE	APP'D
1			
2			
3			
4			
5			
6			
7			

REV	DESCRIPTION	DATE	APP'D
1			
2			
3			
4			
5			
6			
7			

REV	DESCRIPTION	DATE	APP'D
1			
2			
3			
4			
5			
6			
7			

REV	DESCRIPTION	DATE	APP'D
1			
2			
3			
4			
5			
6			
7			

REV	DESCRIPTION	DATE	APP'D
1			
2			
3			
4			
5			
6			
7			

REV	DESCRIPTION	DATE	APP'D
1			
2			
3			
4			
5			
6			
7			

REV	DESCRIPTION	DATE	APP'D
1			
2			
3			
4			
5			
6			
7			

REV	DESCRIPTION	DATE	APP'D
1			
2			
3			
4			
5			
6			
7			

REV	DESCRIPTION	DATE	APP'D
1			
2			
3			
4			
5			
6			
7			

REV	DESCRIPTION	DATE	APP'D
1			
2			
3			
4			
5			
6			
7			

REV	DESCRIPTION	DATE	APP'D
1			
2			
3			
4			
5			
6			
7			

REV	DESCRIPTION	DATE	APP'D
1			
2			
3			
4			
5			
6			
7			

REV	DESCRIPTION	DATE	APP'D
1			
2			
3			
4			
5			
6			
7			

REV	DESCRIPTION	DATE	APP'D
1			
2			
3			
4			
5			
6			
7			

REV	DESCRIPTION	DATE	APP'D
1			
2			
3			
4			
5			
6			
7			

REV	DESCRIPTION	DATE	APP'D
1			
2			
3			
4			
5			
6			
7			

REV	DESCRIPTION	DATE	APP'D
1			
2			
3			
4			
5			
6			
7			

REV	DESCRIPTION	DATE	APP'D
1			
2			
3			
4			
5			
6			
7			

REV	DESCRIPTION	DATE	APP'D
1			
2			
3			
4			
5			
6			
7			

REV	DESCRIPTION	DATE	APP'D
1			
2			
3			
4			
5			
6			
7			

REV	DESCRIPTION	DATE	APP'D
1			
2			
3			
4			
5			
6			
7			

REV	DESCRIPTION	DATE	APP'D
1			
2			
3			
4			
5			
6			
7			

REV	DESCRIPTION	DATE	APP'D
1			
2			
3			
4			
5			
6			
7			

REV	DESCRIPTION	DATE	APP'D
1			
2			
3			
4			
5			
6			
7			

REV	DESCRIPTION	DATE	APP'D
1			
2			
3			
4			
5			
6			
7			

REV	DESCRIPTION	DATE	APP'D
1			
2			
3			
4			
5			
6			

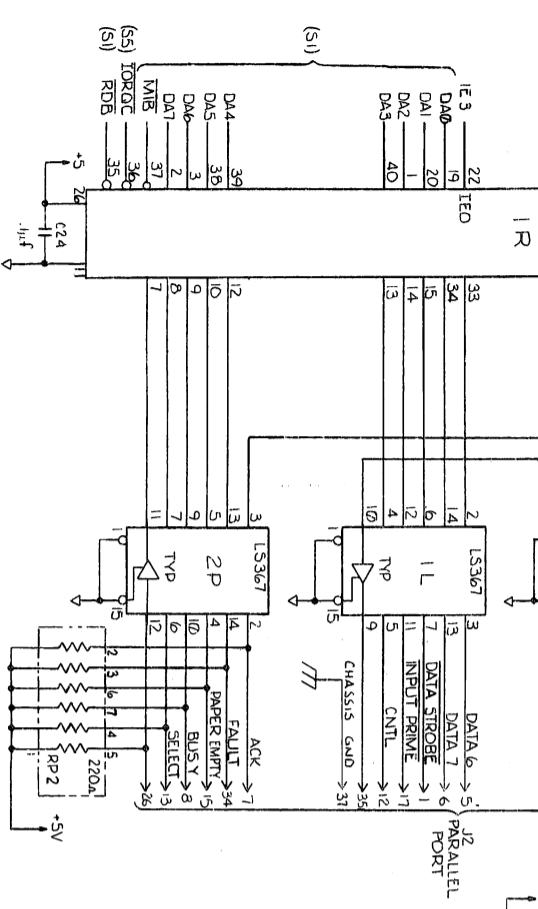
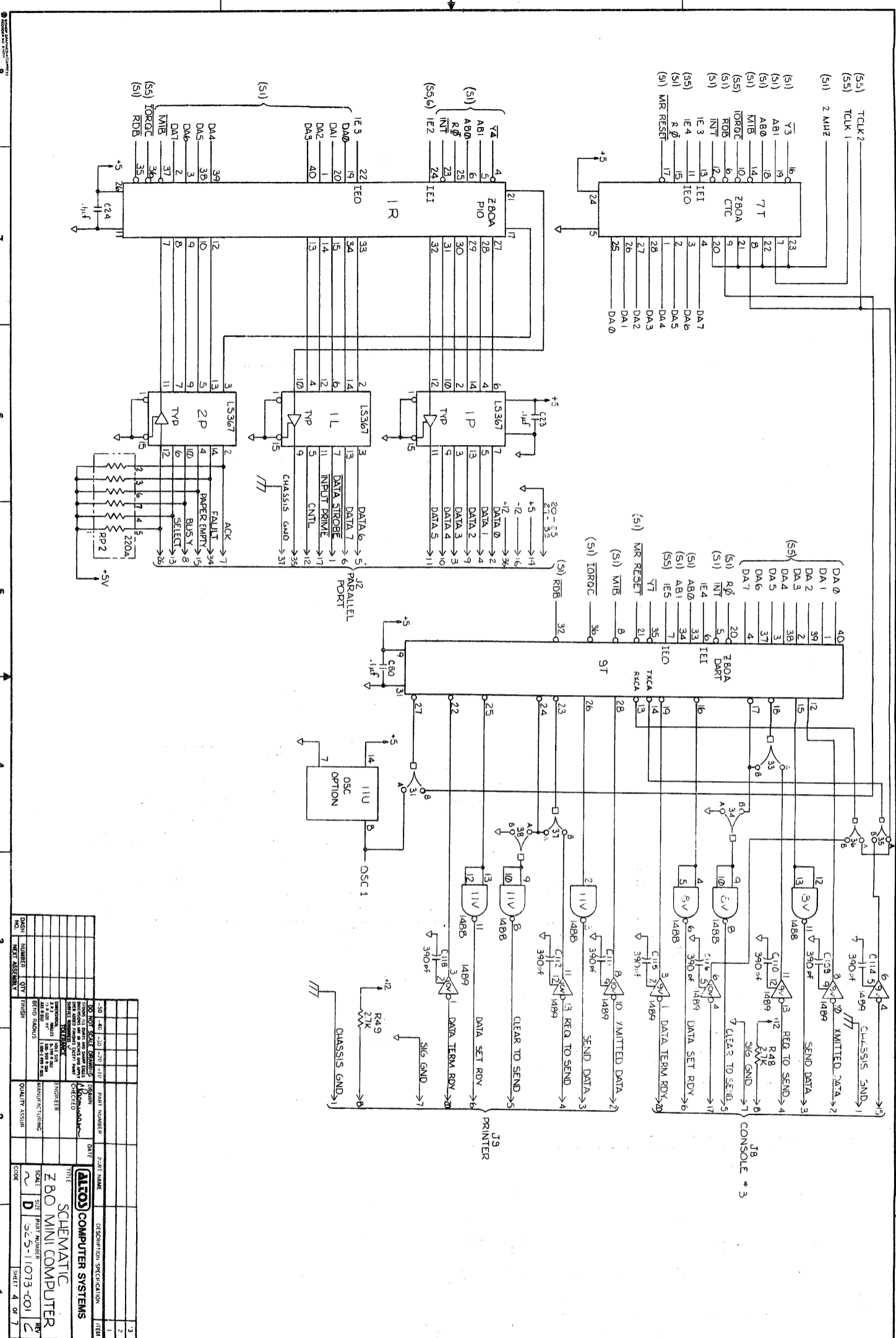

NO.	DESCRIPTION	QTY	UNIT
1	Z80A	1	IC
2	74LS367	2	IC
3	74LS367	1	IC
4	74LS367	1	IC
5	74LS367	1	IC
6	74LS367	1	IC
7	74LS367	1	IC
8	74LS367	1	IC
9	74LS367	1	IC
10	74LS367	1	IC
11	74LS367	1	IC
12	74LS367	1	IC
13	74LS367	1	IC
14	74LS367	1	IC
15	74LS367	1	IC
16	74LS367	1	IC
17	74LS367	1	IC
18	74LS367	1	IC
19	74LS367	1	IC
20	74LS367	1	IC
21	74LS367	1	IC
22	74LS367	1	IC
23	74LS367	1	IC
24	74LS367	1	IC
25	74LS367	1	IC
26	74LS367	1	IC
27	74LS367	1	IC
28	74LS367	1	IC
29	74LS367	1	IC
30	74LS367	1	IC
31	74LS367	1	IC
32	74LS367	1	IC
33	74LS367	1	IC
34	74LS367	1	IC
35	74LS367	1	IC
36	74LS367	1	IC
37	74LS367	1	IC
38	74LS367	1	IC
39	74LS367	1	IC
40	74LS367	1	IC

NO.	DESCRIPTION	QTY	UNIT
1	Z80A	1	IC
2	74LS367	2	IC
3	74LS367	1	IC
4	74LS367	1	IC
5	74LS367	1	IC
6	74LS367	1	IC
7	74LS367	1	IC
8	74LS367	1	IC
9	74LS367	1	IC
10	74LS367	1	IC
11	74LS367	1	IC
12	74LS367	1	IC
13	74LS367	1	IC
14	74LS367	1	IC
15	74LS367	1	IC
16	74LS367	1	IC
17	74LS367	1	IC
18	74LS367	1	IC
19	74LS367	1	IC
20	74LS367	1	IC
21	74LS367	1	IC
22	74LS367	1	IC
23	74LS367	1	IC
24	74LS367	1	IC
25	74LS367	1	IC
26	74LS367	1	IC
27	74LS367	1	IC
28	74LS367	1	IC
29	74LS367	1	IC
30	74LS367	1	IC
31	74LS367	1	IC
32	74LS367	1	IC
33	74LS367	1	IC
34	74LS367	1	IC
35	74LS367	1	IC
36	74LS367	1	IC
37	74LS367	1	IC
38	74LS367	1	IC
39	74LS367	1	IC
40	74LS367	1	IC

NO.	DESCRIPTION	QTY	UNIT
1	Z80A	1	IC
2	74LS367	2	IC
3	74LS367	1	IC
4	74LS367	1	IC
5	74LS367	1	IC
6	74LS367	1	IC
7	74LS367	1	IC
8	74LS367	1	IC
9	74LS367	1	IC
10	74LS367	1	IC
11	74LS367	1	IC
12	74LS367	1	IC
13	74LS367	1	IC
14	74LS367	1	IC
15	74LS367	1	IC
16	74LS367	1	IC
17	74LS367	1	IC
18	74LS367	1	IC
19	74LS367	1	IC
20	74LS367	1	IC
21	74LS367	1	IC
22	74LS367	1	IC
23	74LS367	1	IC
24	74LS367	1	IC
25	74LS367	1	IC
26	74LS367	1	IC
27	74LS367	1	IC
28	74LS367	1	IC
29	74LS367	1	IC
30	74LS367	1	IC
31	74LS367	1	IC
32	74LS367	1	IC
33	74LS367	1	IC
34	74LS367	1	IC
35	74LS367	1	IC
36	74LS367	1	IC
37	74LS367	1	IC
38	74LS367	1	IC
39	74LS367	1	IC
40	74LS367	1	IC

NO.	DESCRIPTION	QTY	UNIT
1	Z80A	1	IC
2	74LS367	2	IC
3	74LS367	1	IC
4	74LS367	1	IC
5	74LS367	1	IC
6	74LS367	1	IC
7	74LS367	1	IC
8	74LS367	1	IC
9	74LS367	1	IC
10	74LS367	1	IC
11	74LS367	1	IC
12	74LS367	1	IC
13	74LS367	1	IC
14	74LS367	1	IC
15	74LS367	1	IC
16	74LS367	1	IC
17	74LS367	1	IC
18	74LS367	1	IC
19	74LS367	1	IC
20	74LS367	1	IC
21	74LS367	1	IC
22	74LS367	1	IC
23	74LS367	1	IC
24	74LS367	1	IC
25	74LS367	1	IC
26	74LS367	1	IC
27	74LS367	1	IC
28	74LS367	1	IC
29	74LS367	1	IC
30	74LS367	1	IC
31	74LS367	1	IC
32	74LS367	1	IC
33	74LS367	1	IC
34	74LS367	1	IC
35	74LS367	1	IC
36	74LS367	1	IC
37	74LS367	1	IC
38	74LS367	1	IC
39	74LS367	1	IC
40	74LS367	1	IC

NO.	DESCRIPTION	QTY	UNIT
1	Z80A	1	IC
2	74LS367	2	IC
3	74LS367	1	IC
4	74LS367	1	IC
5	74LS367	1	IC
6	74LS367	1	IC
7	74LS367	1	IC
8	74LS367	1	IC
9	74LS367	1	IC
10	74LS367	1	IC
11	74LS367	1	IC
12	74LS367	1	IC
13	74LS367	1	IC
14	74LS367	1	IC
15	74LS367	1	IC
16	74LS367	1	IC
17	74LS367	1	IC
18	74LS367	1	IC
19	74LS367	1	IC
20	74LS367	1	IC
21	74LS367	1	IC
22	74LS367	1	IC
23	74LS367	1	IC
24	74LS367	1	IC
25	74LS367	1	IC
26	74LS367	1	IC
27	74LS367	1	IC
28	74LS367	1	IC
29	74LS367	1	IC
30	74LS367	1	IC
31	74LS367	1	IC
32	74LS367	1	IC
33	74LS367	1	IC
34	74LS367	1	IC
35	74LS367	1	IC
36	74LS367	1	IC
37	74LS367	1	IC
38	74LS367	1	IC
39	74LS367	1	IC
40	74LS367	1	IC

NO.	DESCRIPTION	QTY	UNIT
1	Z80A	1	IC
2	74LS367	2	IC
3	74LS367	1	IC
4	74LS367	1	IC
5	74LS367	1	IC
6	74LS367	1	IC
7	74LS367	1	IC
8	74LS367	1	IC
9	74LS367	1	IC
10	74LS367	1	IC
11	74LS367	1	IC
12	74LS367	1	IC
13	74LS367	1	IC
14	74LS367	1	IC
15	74LS367	1	IC
16	74LS367	1	IC
17	74LS367	1	IC
18	74LS367	1	IC
19	74LS367	1	IC
20	74LS367	1	IC
21	74LS367	1	IC
22	74LS367	1	IC
23	74LS367	1	IC
24	74LS367	1	IC
25	74LS367	1	IC
26	74LS367	1	IC
27	74LS367	1	IC
28	74LS367	1	IC
29	74LS367	1	IC
30	74LS367	1	IC
31	74LS367	1	IC
32	74LS367	1	IC
33	74LS367	1	IC
34	74LS367	1	IC
35	74LS367	1	IC
36	74LS367	1	IC
37	74LS367	1	IC
38	74LS367	1	IC
39	74LS367	1	IC
40	74LS367	1	IC

NO.	DESCRIPTION	QTY	UNIT
1	Z80A	1	IC
2	74LS367	2	IC
3	74LS367	1	IC
4	74LS367	1	IC
5	74LS367	1	IC
6	74LS367	1	IC
7	74LS367	1	IC
8	74LS367	1	IC
9	74LS367	1	IC
10	74LS367	1	IC
11	74LS367	1	IC
12	74LS367	1	IC
13	74LS367	1	IC
14	74LS367	1	IC
15	74LS367	1	IC
16	74LS367	1	IC
17	74LS367	1	IC
18	74LS367	1	IC
19	74LS367	1	IC
20	74LS367	1	IC
21	74LS367	1	IC
22	74LS367	1	IC
23	74LS367	1	IC
24	74LS367	1	IC
25	74LS367	1	IC
26	74LS367	1	IC
27	74LS367	1	IC
28	74LS367	1	IC
29	74LS367	1	IC
30	74LS367	1	IC
31	74LS367	1	IC
32	74LS367	1	IC
33			

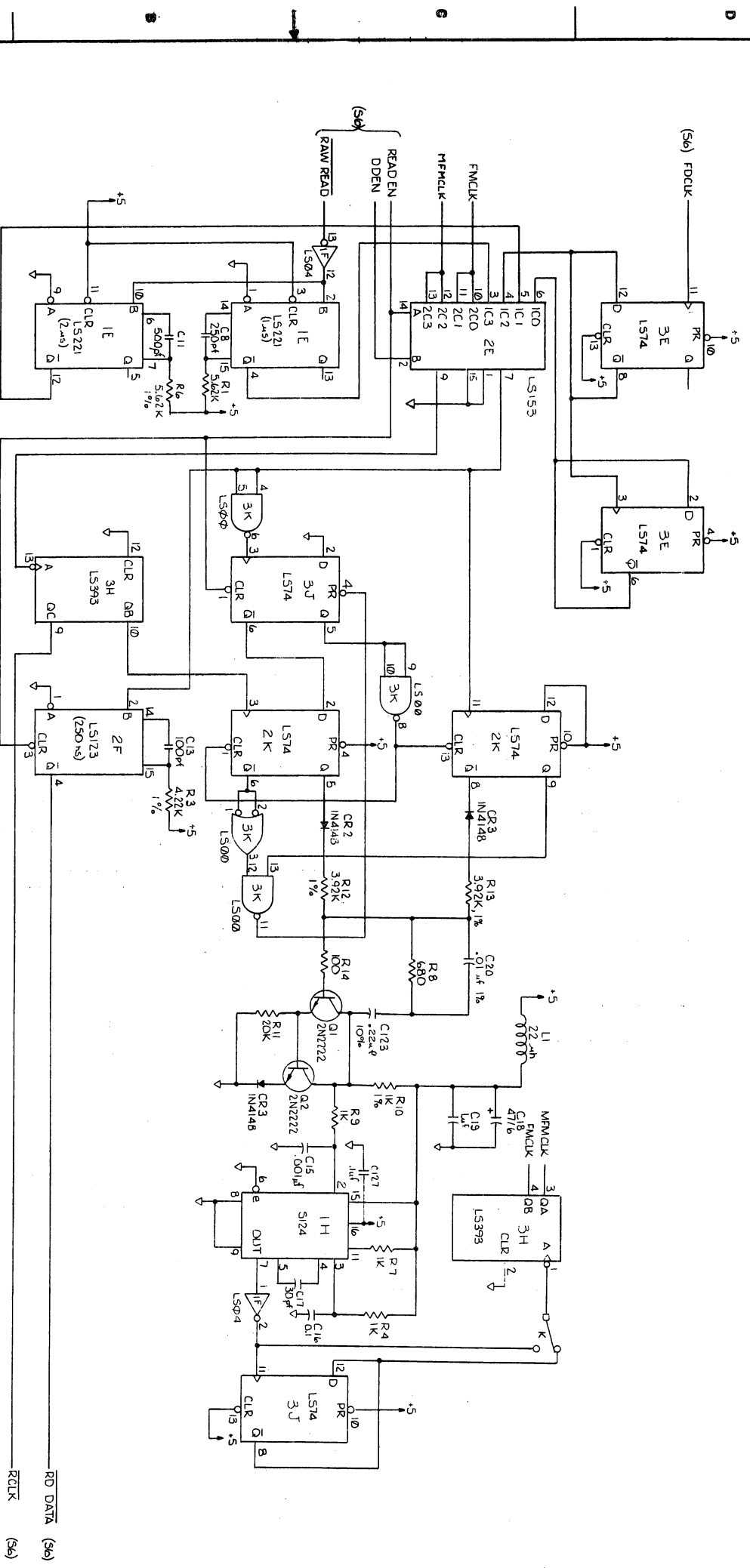

NO.	DATE	BY	CHKD.	DESCRIPTION
1	9-4-61	W. J.
2
3

DESIGN NO.	625-11073-001
REV.	7
TITLE	ZBC MINI COMPUTER
SCALE	1:1
DATE	9-4-61
BY	W. J. ...
CHKD.	...
APPROVED	...

REV	DESCRIPTION	DATE	APPROVED

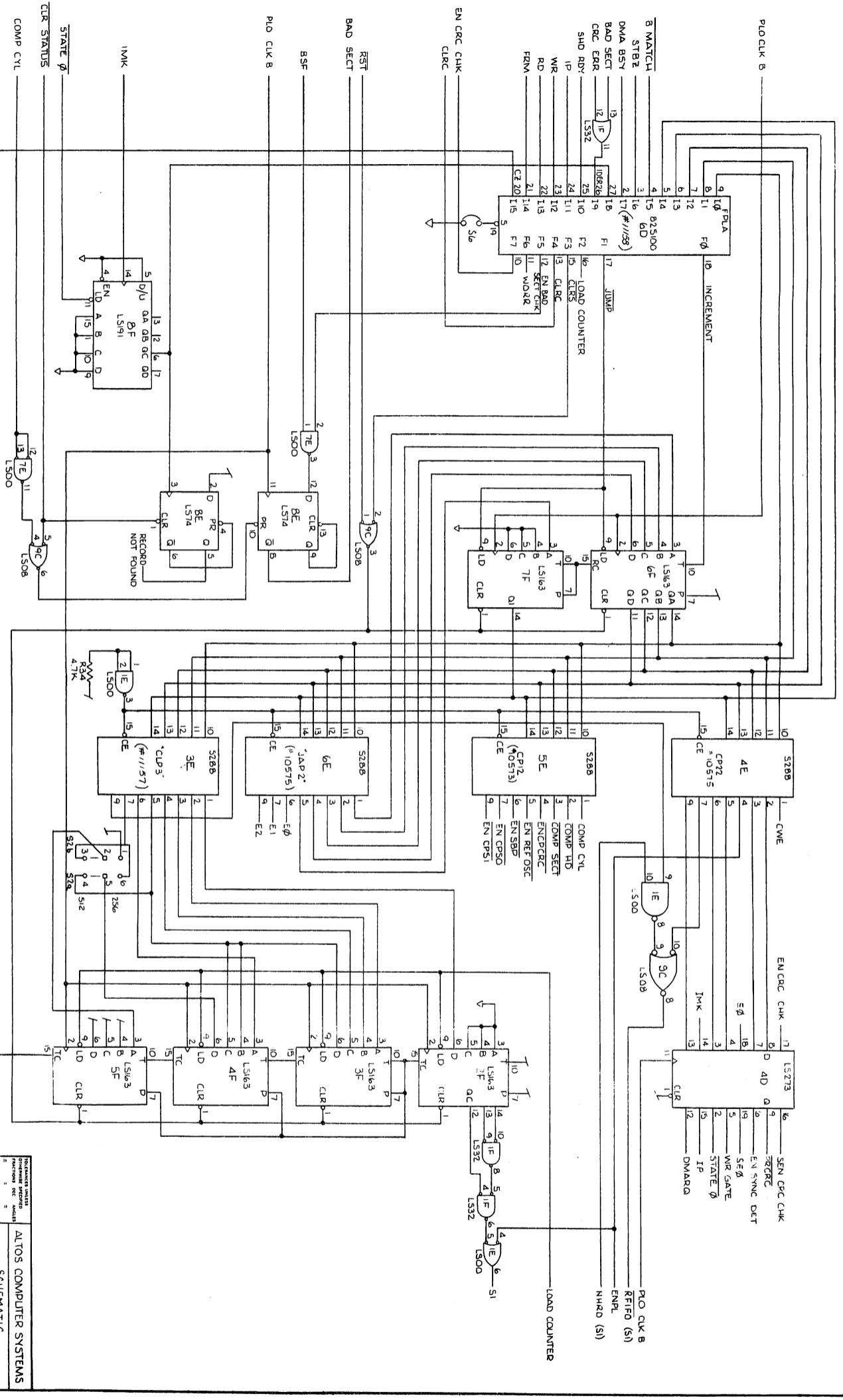

REV	DESCRIPTION	DATE	APPROVED

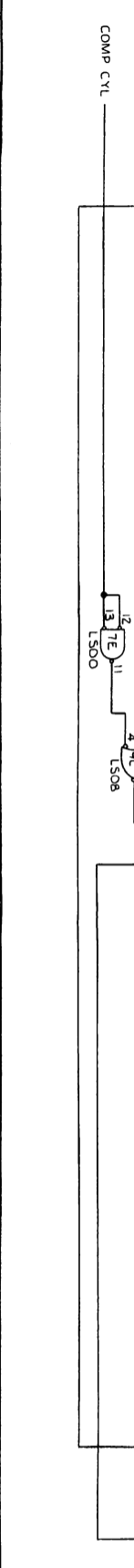

ALDOS COMPUTER SYSTEMS
 SCHEMATIC,
 5 1/4" CONTROLLER P.C.B.
 DATE 1/27/68
 SHEET NO. 1
 OF 5
 DO NOT SCALE DRAWING

REV	DESCRIPTION	DATE	APPROVED

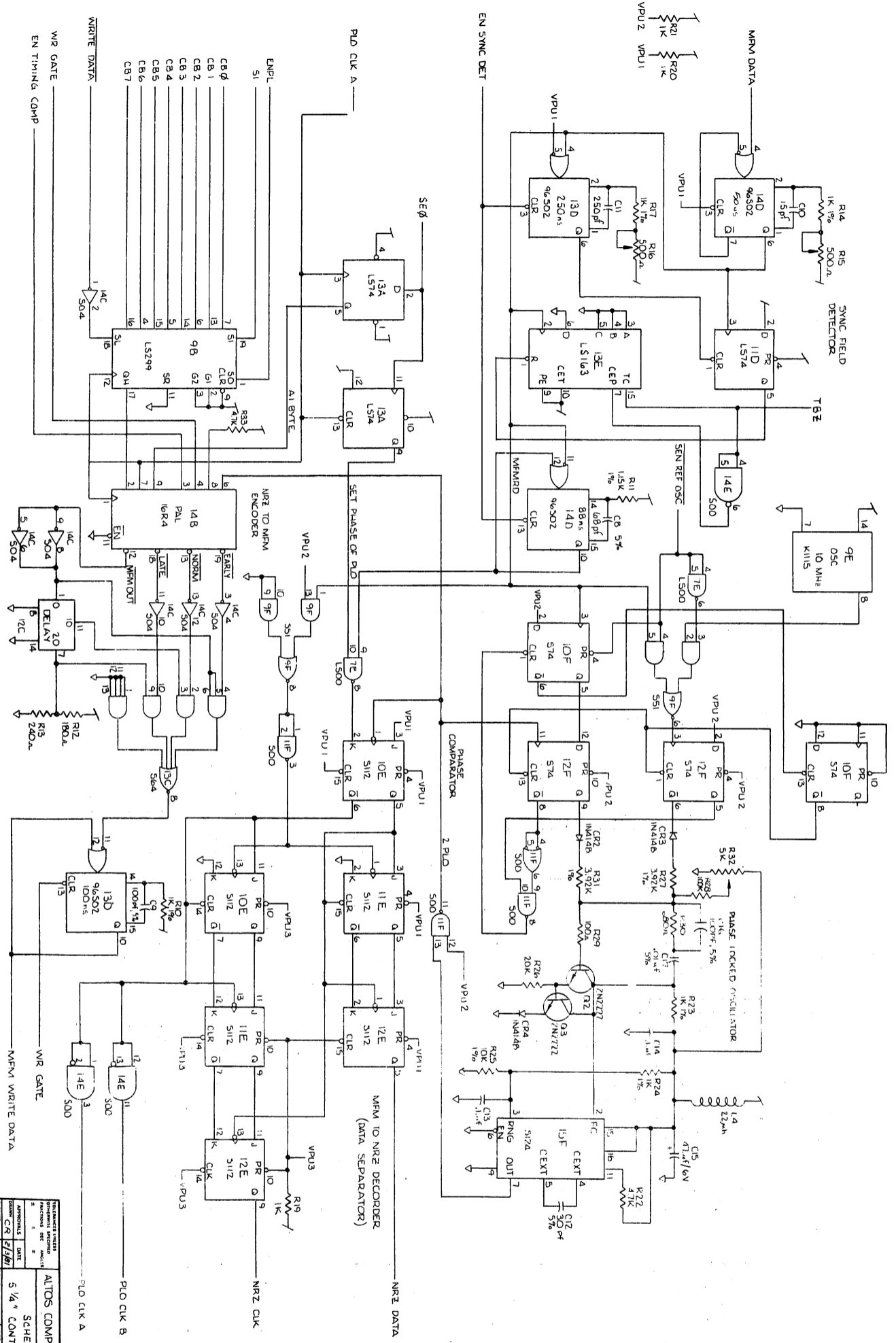

REV	DESCRIPTION	DATE	APPROVED

MANUFACTURER: ALDOS COMPUTER SYSTEMS
 PART NUMBER: 5 1/4" CONTROLLER PCB.
 DATE: 1/27/67
 SCALE: D
 DRAWING NO: 625-11099-001
 SHEET: 5 OF 5
 DO NOT SCALE DRAWING

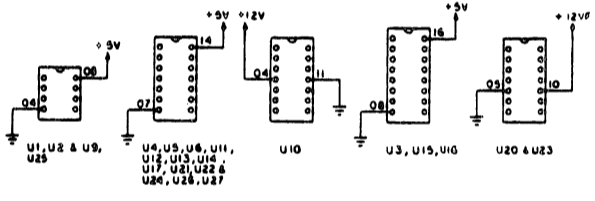
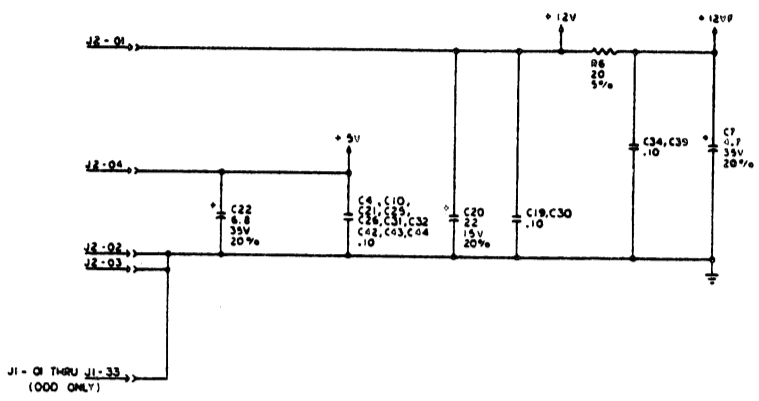

- NOTES:
1. RESISTOR VALUES ARE IN OHMS, 1/4 W, 21%
 2. CAPACITANCE VALUES ARE IN MICROFARADS
 3. DRAWING INTERPRETATION PER 434226599
 4. WRITE PROTECT SWITCH SHOWN IN THE WRITE PROTECTED POSITION; DISKETTE INSERTED AND WRITE PROTECT SLOT COVERED.
 5. OPTICAL TRACK ZERO SWITCH: CARRIAGE FLAG INTERRUPTS LIGHT BEAM AT TRACK ZERO POSITION

CDC Floppy Disk Drive Schematic

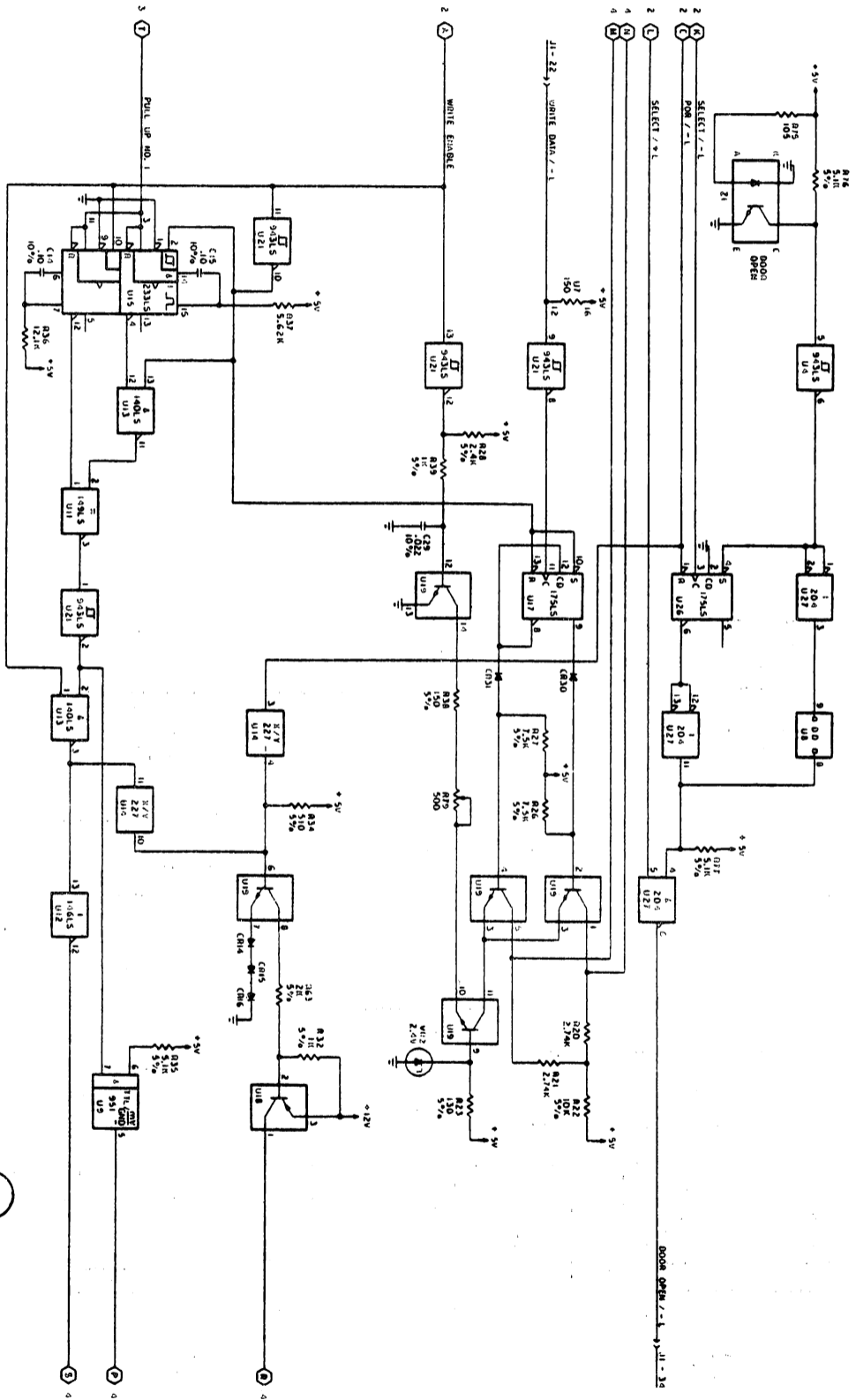

CDC Floppy Disk Drive Schematic



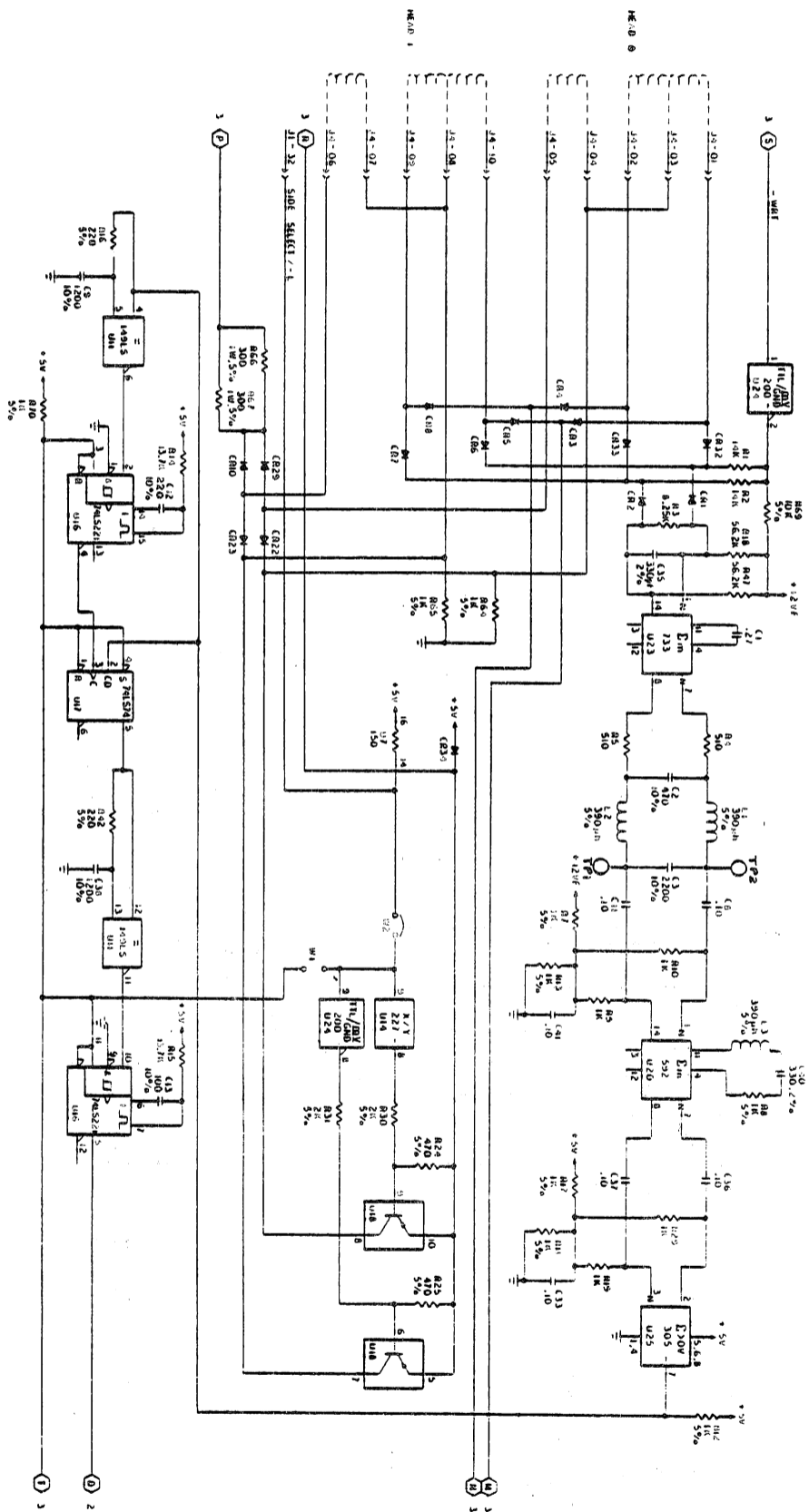

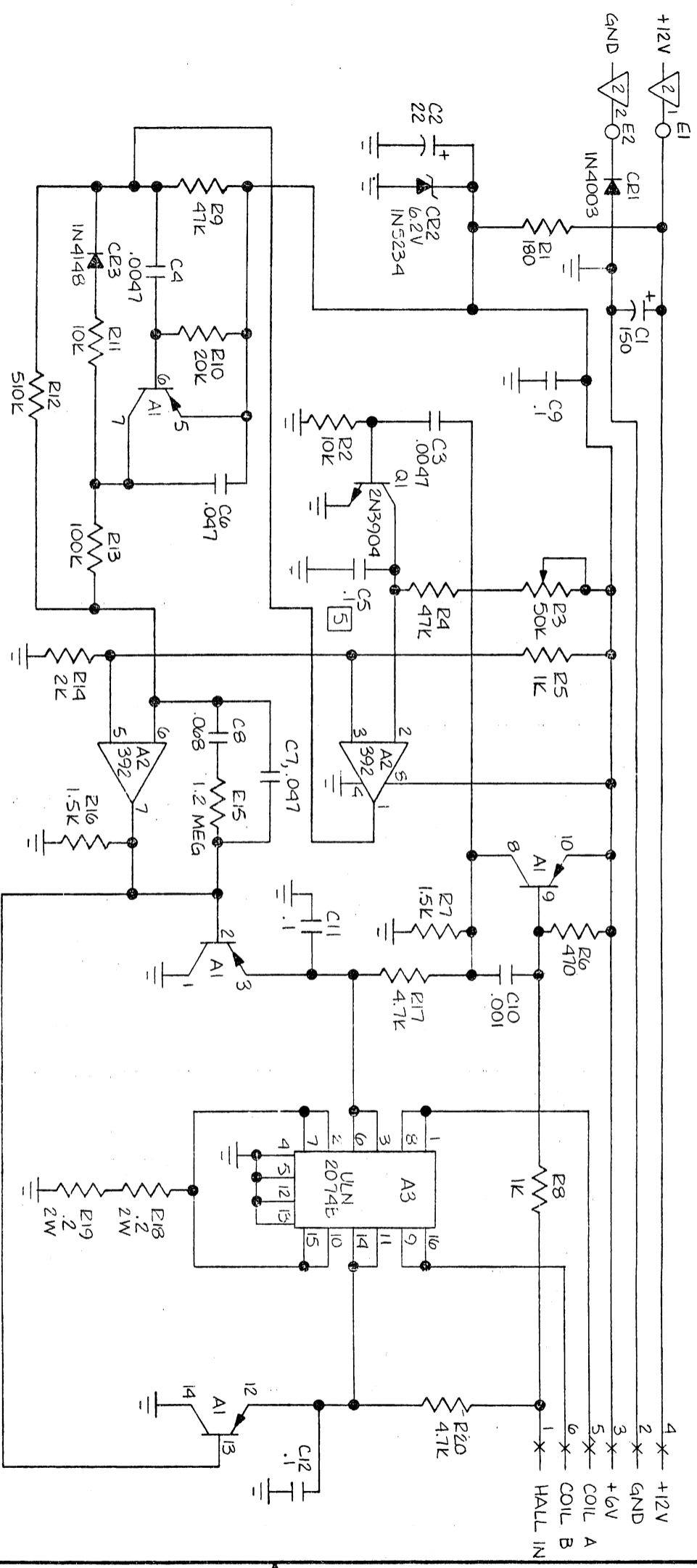

CDC Floppy Disk Drive Schematic

PART NO.
20003-001



NOTES: UNLESS OTHERWISE SPECIFIED.

1. ALL RESISTORS ARE IN OHMS, 1/4 W, 5%
2. ALL CAPACITORS ARE IN MICROFARADS, 10%
3. X INDICATES J1
4.  INDICATES J2
5.  CS - POLYCARBONATE, 50V, ±10%

MATERIAL:		MUST CONFORM TO ENGINEERING SPEC. 30130-001		EC HISTORY		TITLE	
TOLERANCE UNLESS OTHERWISE NOTED		DATE	NO.	PWD ASSY - MTR Cntel (SCHEMATIC)		RELEASED FOR ASSEMBLY	
LINEAR		12/31/2002	1	DETAIL		SHEET 1 OF 6	
HARDNESS		DESIGN		APPRO		SCALE	
SURFACE TREATMENT		CHECKS		APPRO		PART NO. 20003-001	
ES		INSIDE		MAX			

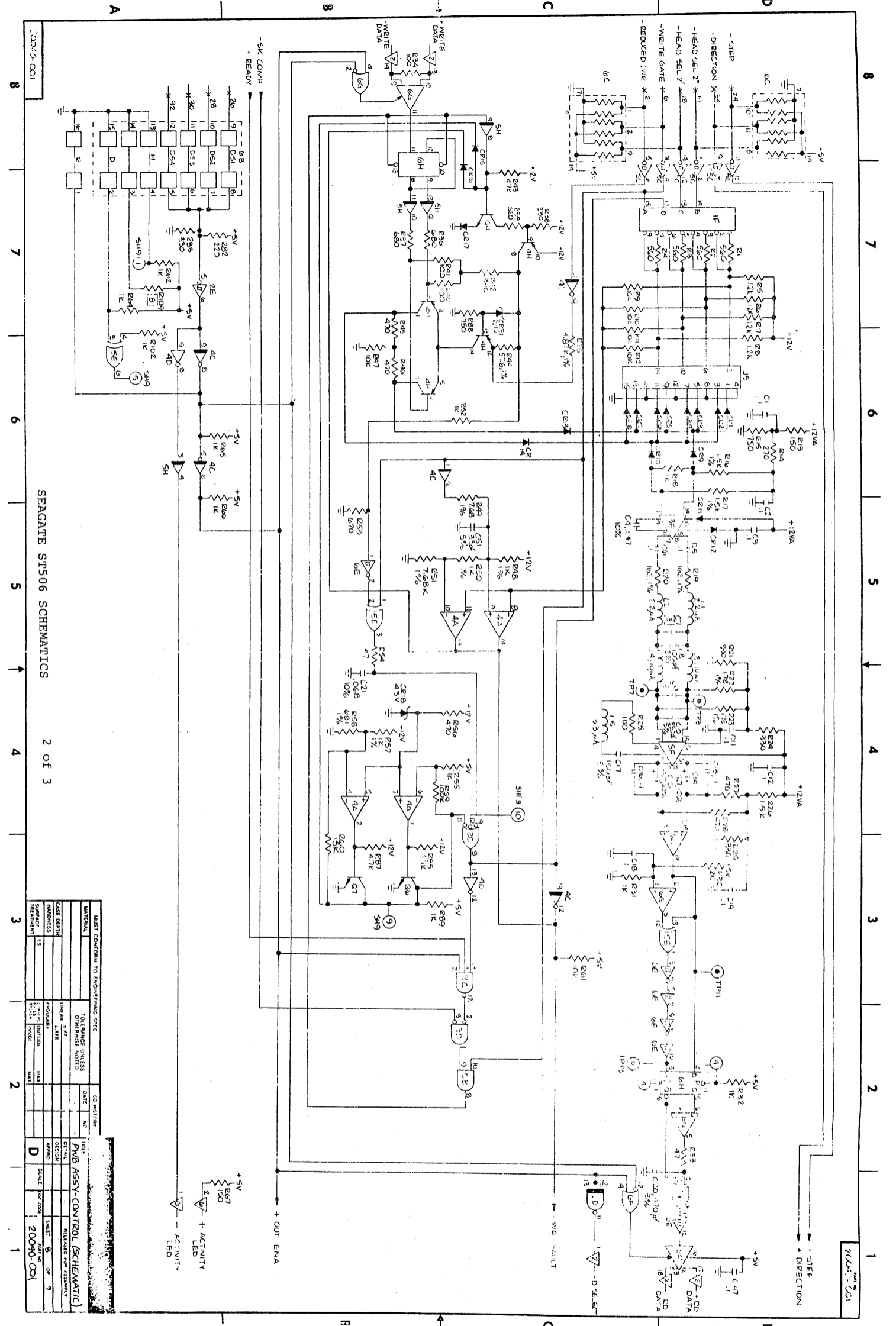

SEAGATE ST506 SCHEMATICS

MUST CONFORM TO ENGINEERING SPEC		EC METRYN	
MATERIAL	TOLERANCE UNLESS OTHERWISE NOTED	DATE	INT.
PWB ASSY-CONTROL (SCHEMATIC)			
DATE DESIGNED	UNLESS NOTED	DESIGN	REVISION
APPROVED	BY	DATE	BY
REVISION	DATE	BY	REASON
1			
2			
3			
4			
5			
6			
7			
8			
9			

SCALE: 200X
 DATE: 2004-01-01

APPENDIX C

SHIPPING DAMAGE AND SYSTEM REPAIR PROCEDURES

If your system was damaged in shipment....

**NOTE: THIS INFORMATION WAS STILL BEING DEVELOPED AT
REVISION D. PRINTING TIME.**

APPENDIX D

INSTRUCTIONS FOR PINNING SERIES 5 PRINTED CIRCUIT BOARDS

The following lists define how the systems should be pinned. The pinning of the PCB's may be changed at a later time to accommodate a particular requirement (i.e., network or bisync operation), refer to schematics in Appendix B for details, and matrix map for position.

SERIES 5-5D

Floppy disk drive, Control Data Corporation (CDC) 9490T:

A 150 ohm line terminator should be installed in position XX. Jumpers should be cut at the shunt module positions 1, 3, 4, 5, and 6. (2, 7 and 8 are not cut).

Or Shugart SA460:

A 220/330 ohm line terminator should be installed at U3. Jumpers should be in positions DS1 and SS, all others are left open.

NOTE

The Shugart is a second-source drive for the CDC 9409T and is interchangeable.

Hard Disk Drive, Segate ST506:

A 220/330 ohm line terminator should be installed at XX. At 6C, the jumper block should be in pins 2-8, leaving pin 1 open. Jumpers at pin 5, 6, and 7 should be cut (2, 3, 4, and 8 are not cut).

5 1/4" Hard Disk Controller Board (11097):

S1a and S1b should be jumpered to 64 (for Seagate ST506).
S2a and S2b should be jumpered to 512 (bytes per sector).
S3 should be jumpered to position 2 (for Z80 systems).

CPU Board (11071):

1, 2 and 42 should be open. Jumper should be placed at 3.
Jumper should be in position 4, 6, 8, 10, 11, 13, 15, 20 and
39. Pins 5, 7, 9, 12, 14, 16-19, and 21-30 should be open.
Sockets at 4U and 4V are empty. This initializes the system
for RS 232 operation rather than networking.

There should be jumper 31 to B, 32 to B, 34 to A, 35 to A,
36 to A, 37 to A, 38 to B, 40 to A, and 41 to B in position.
This disables the RTS/CTS loops in the RS 232 circuits.

SERIES 5-15D

Right-hand side of floppy disk drive, CDC 9509T (Drive 1):

Jumpers should be cut at the shunt module positions 1, 3, 4,
5, and 6 (2, 7, and 8 are not cut).

Or Shugart SA460 (Drive 1):

Jumpers only in positions DS1 and SS, leave all others are
open.

Left-hand side of floppy disk drive, CDC 9409T (Drive 2):

A 150/ ohm line terminator should be installed at XX.
Jumpers at the shunt module positions 1, 2, 4, 5, and 6 (3,
7, and 8 are not cut).

Or Shugart SA460 (Drive 2):

A 220/330 ohm line terminators should be installed at U3.
Jumpers in positions DS2 and SS, leave all others are open.

CPU Board (11071):

Jumper position 1, 2, 3, and 42 are open. Jumpers at 4 and
39. Jumpers are installed in positions 6, 8, 10, 11, 13, 15
and 20. Leave pins 5, 7, 9, 12, 14, 16-19, and 21-30 open.

Jumpers should be in position 31 to B, 32 to B, 33 to B, 34
to A, 35 to A, 36 to A, 37 to A, 38 to B, 40 to A and 41 to
B.

Altos Computer Systems
World Headquarters
2360 Bering Drive
San Jose, CA 95131
U.S.A.
(408) 946-6700
Telex: 171562 ALTOS SJN