

A PennWell Publication

JANUARY 1984

COMPUTER DESIGN

THE MAGAZINE OF COMPUTER BASED SYSTEMS

**SPECIAL REPORT:
DESIGN TOOLS**



It's just not fair to claim that **TEMPLATE**[®] is the best graphics software available. Our competition's already discouraged.

And we like competition. We really do. It's just that it's difficult, if not impossible, to find graphics software as efficient and functional as **TEMPLATE**. Try as you might. **TEMPLATE** is the hands-down winner. With true device-independence and intelligence, total graphics functionality for CAD, scientific analysis, seismic work, process control, molecular modeling, and a host of other applications.



In almost any environment, whether it's batch or interactive, 2D or 3D, **TEMPLATE** wins. Benchmark tests prove it. **TEMPLATE**, besides being a true 3D graphics package for 32-bit or larger computers, features powerful commands that provide matchless productivity. **TEMPLATE** makes optimal use of available computer resources, giving you fast, efficient computer graphics program execution. And it supports over 125 graphics devices, from dumb terminals to sophisticated systems.

We also provide on-site installation and training, continuous updates, a regular flow of new device drivers, and ongoing documentation. What's more, we back you up with a telephone hotline so **TEMPLATE** software specialists can provide help if you need it.

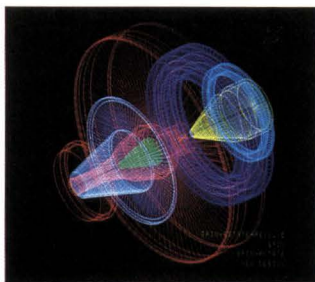

But let's be fair. If you're looking for graphics software, call our competitors first. Find out what they have to say about theirs. Then call us, and find out why **TEMPLATE** really has no competition.

And why the competition has been so discouraged for so long.

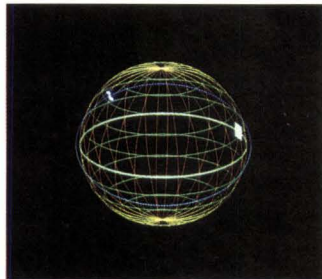

 **MEGATEK
CORPORATION**
A UNITED TELECOM COMPANY
Making History out of State-of-the-Art

World Headquarters • 9605 Scranton Road • San Diego, California 92121 • 619/455-5590 • TWX: 910-337-1270
European Headquarters • 34, avenue du Tribunal-Fédéral • CH-1005 Lausanne, Switzerland • Telephone: 41/21/20 70 55 • Telex: 25 037 mega ch

You've concluded that you need the performance and capacity that only an 8 inch Winchester drive can provide. Which one should you buy?

There are 109 different models available.

Of this 109, only 39 are 8 inch floppy form-factor compatible.

28 of these 109 perform an average seek in 30 milliseconds or less.

And of this 109, only 17 offer true SMD compatibility.

Puzzled?

Only one company provides a disk drive with all the features —

Kennedy and Model 7300

with the right size, the right interfaces and the right price.

Write or give us a call.

KENNEDY

An Allegheny International Company

1600 Shamrock Ave., Monrovia, CA. 91016

(213) 357-8831 TELEX 472-0116 KENNEDY

TWX 910-585-3249

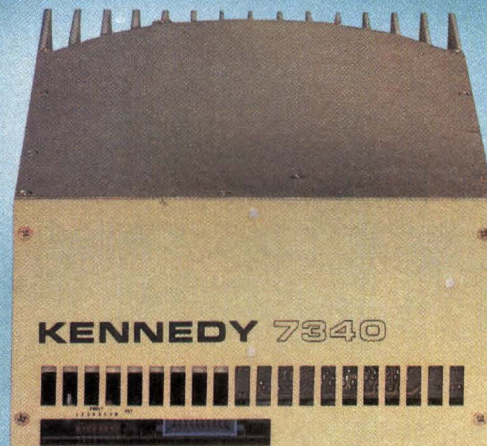
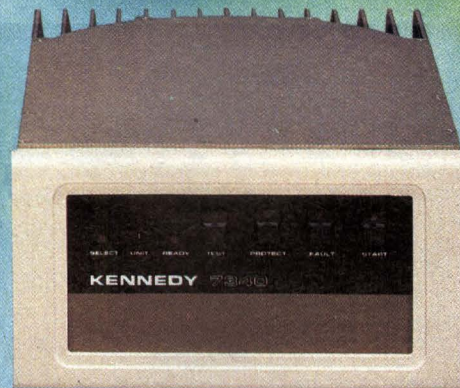

SPECIFICATIONS:

- 41 and 82 MB Capacities
- Rotary Voice Coil 30 msec average seek
- SMD, ANSI or PICO BUS Interfaces
- 1209 KByte/sec. transfer rate
- Available 30-45 days ARO
- Q100: \$2,560/\$3,195

KENNEDY • QUALITY • COUNT ON IT

CIRCLE 2



TIGER TOUGH.

Hitachi's new TIGER TABLET is a rugged, low-cost, easy-to use digitizer using interactive graphics, data entry and menu selection. Operating by electromagnetic induction, TIGER TABLET offers both high quality and reliability in a compact, lightweight, and easy-to-maintain format. The stylus pen and 4- or 12-button cursors offer outstanding performance. Other features include:

- 0.001" resolution, ± 0.01 " accuracy, ± 0.0015 " repeatability.
- Self-diagnostics — minimum MTBR.
- No discrete elements on its PC board — high MTBF.
- Dual-Port RS-232C plus 8-bit parallel interfaces.
- Condensed logic — electronics housed inside tablet.
- Ergonomic design — wedge-shaped, stylus receptacle and groove, rounded edges, indicator lights, external recessed dip switches and connectors.
- 2 year warranty on all tablets; 6 months on its electronics.
- Versatile — will interface with most computer formats.

- Compliant with UL, FCC and other standards.
- Signal/Noise Ratio — can withstand up to 500 volts electrical interference.
- Reliability — unaffected by such factors as graphite, magnets, temperature, humidity, etc. No adjustments necessary.
- Price — under \$900 list.
- Options — 4- or 12-button cursor, stylus pen, power supply (standard or wall mountable), GPIB, 16-bit parallel and TTL serial interfaces.

- Other models — 12" x 16", 15" x 15", 22" x 22", 36" x 48" (opaque and backlighted), 44" x 60".

Hitachi's eighty plus years of manufacturing experience has resulted in countless reliable, innovative and cost-effective products. For more information on our new TIGER TABLET, call us at (213) 533-0888 and listen to us roar. Special discounts available.

Dealer/Distributor inquiries invited.



HITACHI

Hitachi America, Ltd.

449 Alaska Avenue • Torrance, California 90503 • (213) 533-0888 • Telex: 472-0173

**IMMEDIATE
DELIVERY**

CIRCLE 3

UP FRONT

IBM exits Josephson work

IBM has reluctantly admitted that its research activity into the fast-speed, low power Josephson technology has been heavily curtailed. The company attributed the decision to both the slow progress on developing a cryogenic processor as the next generation computer, and to the faster development in alternative technologies such as gallium arsenide. Work in Josephson circuits has also been severely limited in other laboratories such as Bell Labs and Sperry R & D Labs. Meanwhile, Hypres Inc, a new company formed by former IBM employees, has announced that it is proceeding at full speed to develop what the company labels a commercially viable "quiteron." This device is similar to a Josephson junction circuit and also operates at cryogenic temperatures. Hypres operates out of Elmsford, NY and has obtained license from IBM to develop a quiteron-based ultrafast signal processor. The company's founder is F. Faris, who developed the quiteron while employed at IBM. Wafer production of the devices is expected to start this month.

MUMS the word

Marking Seagate's (Scotts Valley, Calif) move into the 8-in. arena, the multi-user memory system (MUMS) combines a half-height, 100-Mbyte Winchester drive with a controller capable of handling a second drive as well as secondary storage devices. To fit the needs of supermicro systems, the ST8100 drive has cut access time down to 30 ms using a proprietary voice coil linear actuator design. Transfer rate is 10 Mbits/s.

A key component of a memory system for multiple users is the ST9100 controller. Designed around the ST412HP interface at the drive level, the controller supports the SCSI interface standard at the system level to sustain the high throughput rates demanded. When packaged with a single drive, half-high, quarter-inch tape cartridge drive, and power supply, controller fits in a cabinet measuring 16 x 16 x 3.5 in. (41 x 41 x 8.9 cm).

Microprocessor extends capabilities of 6502

Removing the limitations that restricted the 6502 from many applications, a 16-bit design executed by Western Design Center (Mesa, Ariz), is hardware and software compatible with that popular chip. The 16-bit 65816 microprocessor, developed in CMOS, runs 6502 software in emulation mode without revisions. This plug-in replacement for the 6502 switches to 16-bit mode under program control. Architecturally, the chip provides an 8-bit external bus and a 16-bit internal bus to speed internal movement of data and instructions. The hybrid 8- and 16-bit processor accommodates the object code of its 8-bit predecessor as a subset.

Digital finally talks

DECTalk, a voice synthesis box that transforms ASCII text to quality speech, has been introduced by Digital Equipment Corp (Maynard, Mass). The device takes any computer output and transforms the ASCII characters into any one of several voices from an older male, to a female, to a young child. The device has an unlimited vocabulary and features speaking rates of from 120 to 350 words/min as well as pronunciation and intonation controls. DEC expects the device to find wide application in telephone access to computer data bases where the push buttons can be used as prompts for gaining information on a variety of subjects. The device also has educational potential in helping handicapped people. DEC engineers attribute the high voice quality to the development of a sophisticated computer model that almost perfectly simulates the human vocal tract. Demonstrated without fanfare in several applications at DECTown in late Aug 1983, the device will be available in quantity in March at an expected price of \$4000.

Transportable personal computer sports versatility

A nationwide introduction of the M3000 by MicroStandard Technologies Inc (New Lebanon, Ohio), at the recent Comdex show was hailed as being the most flexible and expandable personal computer for industrial/military applications. The ruggedized unit is water-resistant and dustproof and occupies a little more than 1 cubic-foot area. The personal computer comes with a choice of Z80A, 8088, 8086, or 68000A processors and allows the user to choose from one of three optional card cages to interface with other peripherals. The three card cage types hold four STD bus, two VME bus, or two S-100 bus boards. In addition, besides the standard 64 Kbytes of internal RAM, an optional 512-Kbyte RAM board can be inserted into one of the STD bus card slots. The color monitor is a full RGB unit with a monochrome version offered as an option. Storage capacity includes one 376-Kbyte 5¼-in. floppy disk with options that include either double-capacity floppies or one floppy and a 10-Mbyte, 5¼-in. Winchester hard disk. Based on the configuration, prices range from \$1645 to \$2895.

Sun shines for engineers

Powerful workstations for software development, document preparation, and CAD/CAM work have been introduced by Sun Microsystems, Inc (Mountain View, Calif). The Sun-2 family of desktop and rackmountable stations is based on a 10-MHz 68010 microprocessor with a 1-Mbyte internal memory that can display bit-mapped graphics of 1152- x 900-dot resolution. A demand-page virtual memory allows for simultaneous display of multiple windows. The machines have been embedded with an advanced version of the Berkeley Unix 4.2 operating system that runs C, Pascal, and Fortran compilers; and the MC68010 assembler. Included in the basic \$16,900 price is an Ethernet interface card and a 9-slot IEEE 796 (Multibus) card cage.

Computer security gets a break

A copyright insurance technique enables software vendors to sell their services over telephone lines without fear that their copyright interests will be violated. Telelok from the Vault Corp (Los Angeles, Calif) allows modem-to-modem communications of programs stored on floppy diskettes in a way that ensures that the receiving party is the only authorized agent for the transmission. A proprietary manufacturing process etches an identifying scribe into the oxide surface of diskettes. The vendors retain a master diskette while the receiving community is given an encrypted version of the program. When this version is played back on the fingerprinted diskette it only permits the receiver to read the program's contents. This two-key encryption method requires the creation of only one master disk, and that backup copies be generated without compromising the security. The Telelok system is transparent to legitimate users and does not require special hardware. The current version is available for MS-DOS-based machines.

Fast chip compares data strings

A special IC that can rapidly search a data base for matching or approximately matching strings has been produced by Proximity Devices Corp (Fort Lauderdale, Fla). The PF474 compares strings up to 127 bytes long to a query string and computes a degree of similarity for each comparison. It also maintains a list of the 16 best matches and provides users with the ability to set the desired degree or proximity. Using its DMA facility, the PF474 can perform 49,600 comparisons and rankings of 8 character strings/s.

COMPUTER DESIGN©1984 (ISSN-0010-4566) is published monthly, with a thirteenth and fourteenth issue respectively in April and October by PennWell Publishing Company, Advanced Technology Group, 119 Russell Street, Littleton, MA 01460. Second-class postage paid at Littleton, MA 01460 and additional mailing offices. COMPUTER DESIGN is distributed without charge to U.S. and W. Europe-based engineers and engineering managers responsible for computer-based equipment and systems design. Subscription rate for others is \$50 in U.S.A. and \$75 elsewhere. Single copy price is \$5.00 in U.S.A. and \$7.50 elsewhere. Microfilm copies of COMPUTER DESIGN are available and may be purchased from University Microfilms, a Xerox Company, 300 North Zeeb Road, Ann Arbor, Michigan 48106. POSTMASTER: CHANGE OF ADDRESS-FORM 3579 to be sent to COMPUTER DESIGN, Circulation Department, P.O. Box 593, Littleton, MA 01460 (USPS 127-340).

Officers of PennWell Publishing Company, 1421 S. Sheridan, Tulsa, OK 74101: P. C. Lauinger, Chairman; Philip C. Lauinger, Jr., President; Joseph A. Wolking, Senior Vice President; H. Mason Fackert, Group Vice President; Carl J. Lawrence, Group Vice President; V. John Maney, Vice President/Finance; L. John Ford, Vice President.

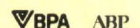
 BPA ABP

* COMPUTER DESIGN is a registered trademark. All rights reserved. No materials may be reprinted without permission. Phone (617) 486-9501.

DATARAM TAKES THE LEAD IN VAX COMPATIBILITY

Three new products establish Dataram as the leader in VAX compatibility.

Our single-board UDA50 compatible controller and our VMS-compatible BULK MEMORY system are industry firsts. Add to that our new 1.0 MB VAX-11/780 memory, and you will understand why Dataram is the VAX-compatible leader.

Call us at (609) 799-0071 today, and learn more about these exciting new products.

1 UDA50 Compatible Controller

Our new S35 controller establishes a new standard for DEC-compatible disk controllers. And for good reasons. It operates with any SMD drive on the VAX (or PDP-11) UNIBUS, at speeds in excess of 2.0 MB/sec. Its speed allows you to take advantage of the popular Fujitsu Eagle. It provides command stacking and enhanced error correcting...and it's packaged on a single hex board.

DEC, PDP, UNIBUS, VAX, and VMS are trademarks of Digital Equipment Corporation.

2 VAX/VMS Compatible BULK SEMI

Our new BS-207 BULK SEMI system offers something never before available — BULK SEMI power and performance for VAX/VMS systems.

BULK SEMI, operating as a high-speed swapping device, has delivered up to 50% improvement in throughput.

Up to 64 MB of high-speed BULK SEMI with ECC standard. Dual-port capability available.

3 1.0 MB VAX-11/780 Memory

Our new DR-278 will operate with all VAX-11/780 computers using DEC's new MS780-E memory systems. But more than simply a direct replacement for the MS780-F memory module, the Dataram DR-278 offers bus disable switch, LED status indicators, and reduced chip count that improves reliability and reduces power consumption. Best of all it's available, today, at a lower cost.

DATARAM

COMPUTER DESIGN[®]

System technology

- 31 **Integrated circuits:** Gallium arsenide chips shine where silicon versions fade
- 40 **Computers:** Fault tolerant systems deal with increased loads
- 44 **Software:** Multipass compilers produce tight code
- 49 **Interconnection & packaging:** IBM packs high density circuits in and lets them breathe

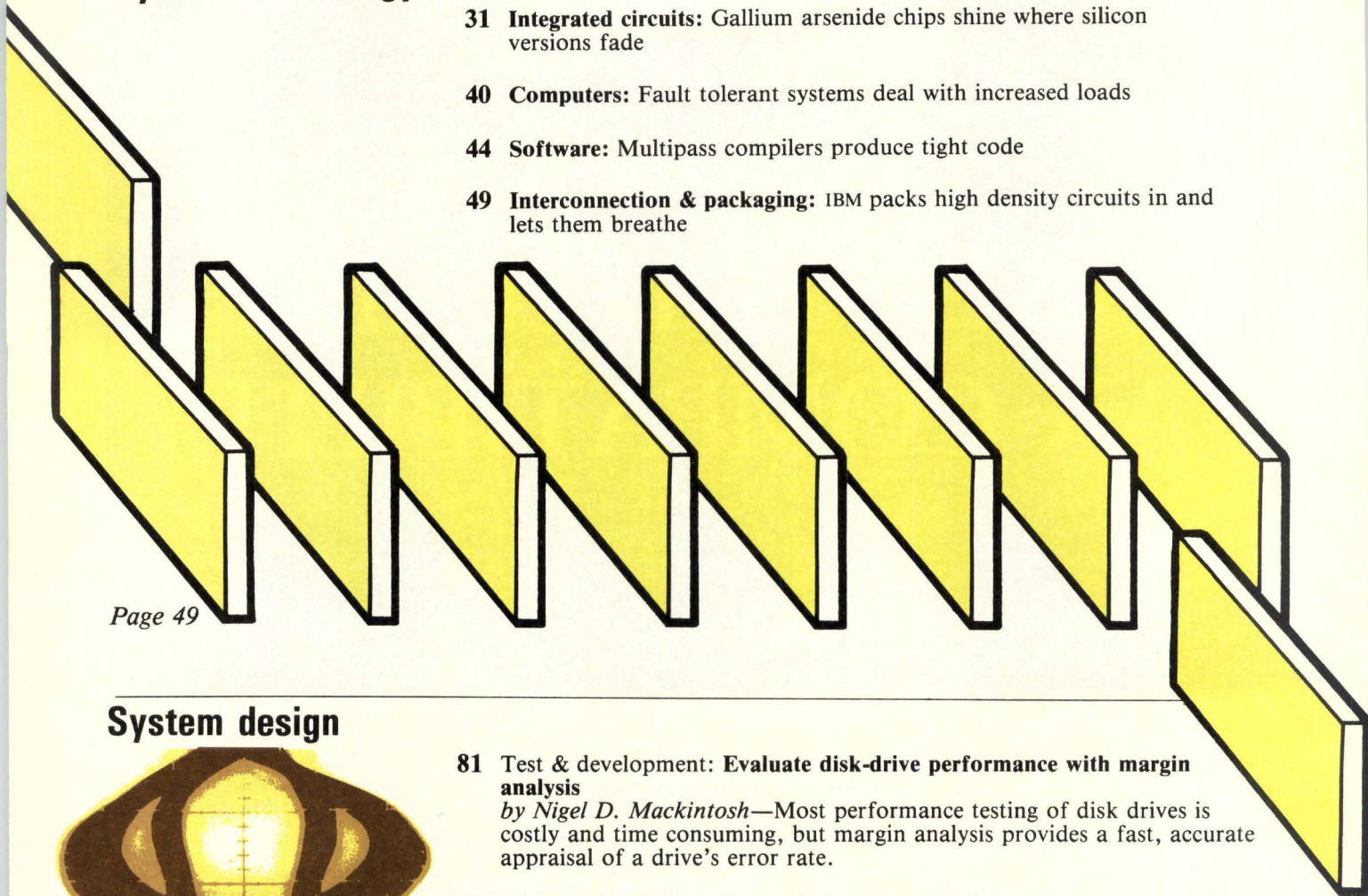

Page 49

System design

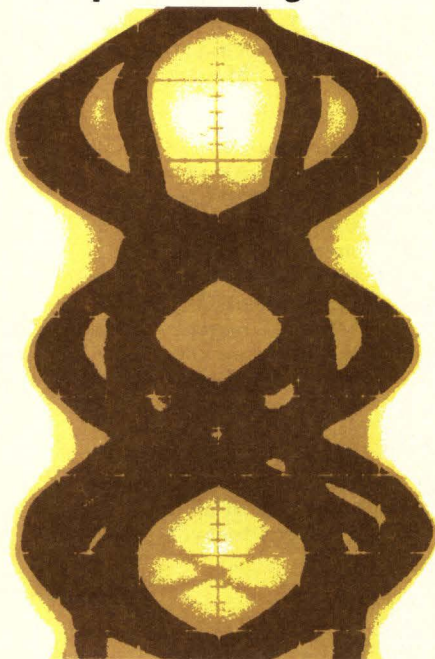

Page 81

- 81 **Test & development: Evaluate disk-drive performance with margin analysis**
by Nigel D. Mackintosh—Most performance testing of disk drives is costly and time consuming, but margin analysis provides a fast, accurate appraisal of a drive's error rate.
- 97 **Integrated circuits: Disk controller chip runs on simple software routines**
by David Davidian—Successful integration of programmable controllers into computer systems requires devices whose command set unburdens both the host processor and the system designer.
- 113 **Software: A second look at computer piracy**
by Estella S. Gold—The case of Apple versus Franklin may give copyright protection to software, but the guidelines are not clear. The decision can be better understood in the context of a cultural collision between the technical and legal professions.
- 127 **Software: Language-based architecture eases system design—III**
by B. Jane Curry—Occam channels are implemented on a multiprocessor Z80 system, using the only computer language designed for multiple processors and true parallel processing.

ISSCC '84

- 61 Next month's International Solid State Circuits Conference in San Francisco will amass a trove of digital and analog circuits to whet the appetites of computer system designers. Among the newcomers are more 1-Mbit memory chips, 20-ns static 64-K RAMs, and faster access EPROMs.

Special report on design tools

- 145** The meteoric growth in complexity of 16- and 32-bit microprocessors places new demands on software developers, who must now work with processor and system functions in terms of high level languages. With the vast number of designs appearing in embedded and realtime control systems, the programmer must nonetheless continue correlating events in software with exactly timed events in the hardware system. Manufacturers of the new generation of microprocessor development systems are rising to these challenges not only with high level programming languages, but also with realtime debugging tools, user interfaces, and communication and management systems to tie the team development effort together.

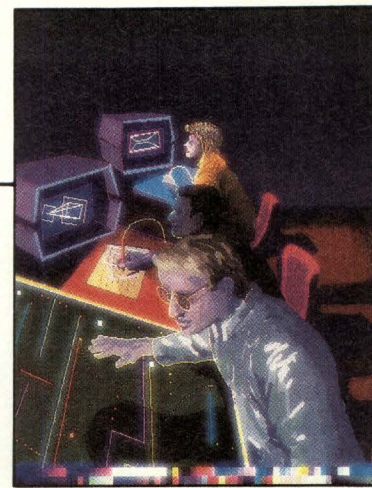

This month's cover was created and designed by Mark Lindquist on the Digital Effects Video Palette III and D-48 high resolution camera system.

System Components

- 217** Subset of VAX architecture meets low end of 32-bit market
218 Two-part array couples memory and logic and adds testing
218 Computerized engineering index: a boon to components research
219 Workstation integrates test and measurement with CAE
219 Development system turns any microcomputer into workstation
220 Ergonomic VDT's calling cards are programmable features and low cost
221 **Computers**
223 **Memory systems**
230 **Interface**
231 **Software**
238 **Peripherals**
241 **Development systems**
242 **Control & automation**
242 **Data communications**
243 **Integrated circuits**
243 **Test & measurement**
243 **System elements**
245 **Power sources & protection**
245 **Microprocessors/microcomputers**
245 **Interconnection & packaging**



Page 219

Departments

- 3** Up front
11 Editorial
17 Letters to the editor
246 Literature
248 Calendar
249 Designer's bookcase
250 System showcase
252 Advertisers' index
257 Reader inquiry card
257 Change of address card

Where in the Microworld

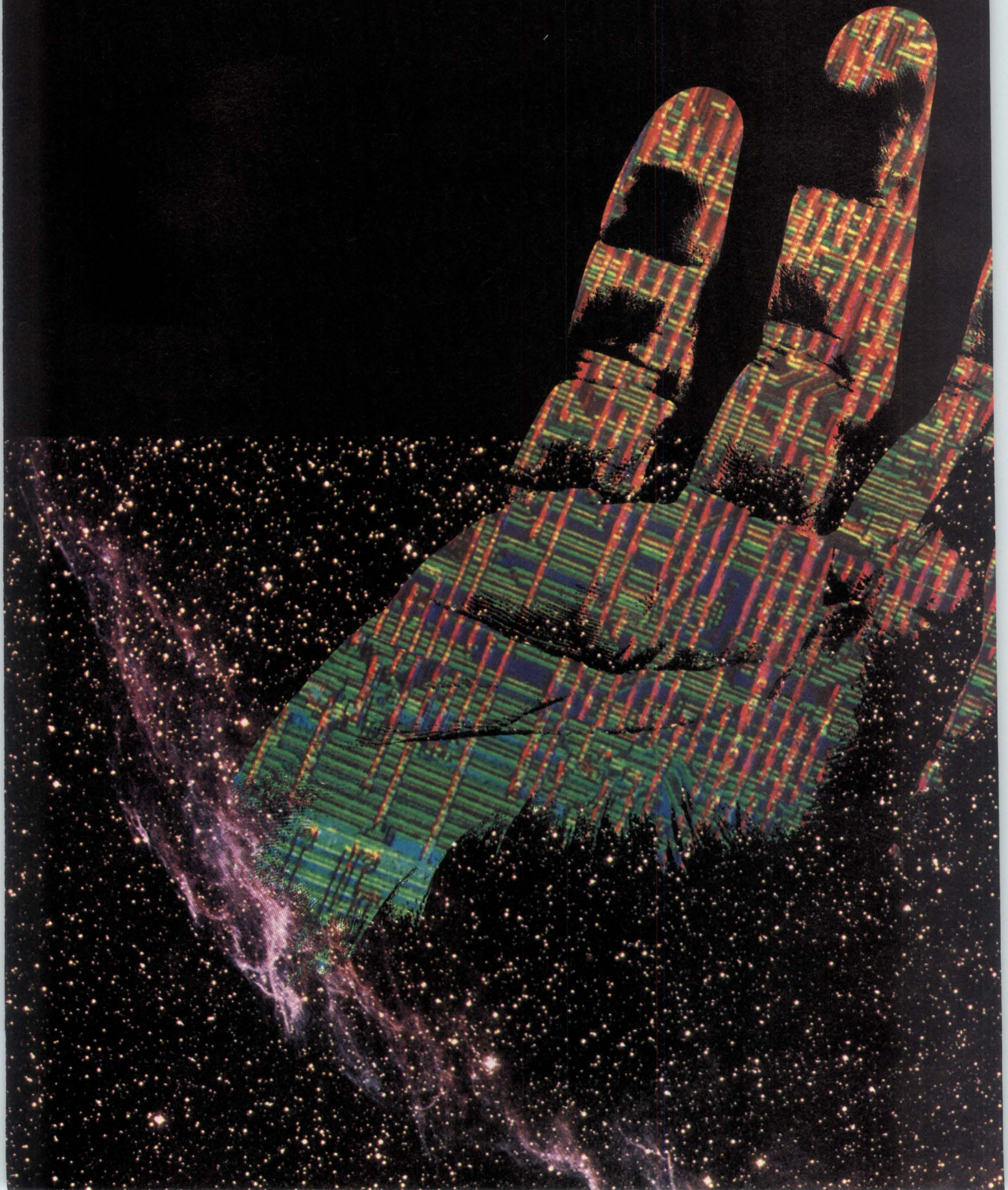

do we go from here?

A good question, and one Zilog is uniquely qualified to answer. Not simply because we developed the Z80[®] CPU, popular as it is, but because we've kept upgrading it with versions that are faster or that take less power.

Because, in the 16-bit field, as the noise of our competition's rhetoric subsides, it's clear that the Z8000[™] CPU is particularly well suited to the more important 16-bit applications from both a hardware and software perspective.

And, because if you've heard about our coming Z80 CPU-compatible 8/16-bit Z800[™] microprocessor and the Z8000-compatible 32-bit Z80,000[™] CPU, or our single-chip Z8070 floating point processor, it is apparent that these machines represent part of a very sophisticated product strategy leading to a level of applications performance and cost-effectiveness unheard of today.

Note, too, that we integrate our own technology upwards into complete computer systems. These range from the amazing Z8[®] family that puts an entire computer onto one chip to the rather phenomenal System 8000 family which offers users a series of UNIX* operating system-based super-microcomputer systems that easily leave many, clumsier, mini-computer ancestors in the dust.

How are we doing all this? Good people. Outstanding facilities. And, not least of all, the kind of committed support from our parent company, Exxon, that allows us to put more of our resources back into R&D,

Development Systems
Peripheral Components
Co-processors/MMU's
8-bit, 16-bit, 32-bit MPU's
One-chip MCU's
16-bit MC Systems
Operating Systems
Languages
Applications

proportionately, than any other company in the business.

Where does the Microworld go from here? Exactly where you want it to go.

For a free poster of the art in this ad and/or our 1983/84 Components Data Book, put your request on company letterhead. Mail to: Zilog, Inc., Components Tech. Publications, 1315 Dell Avenue, MS A1-4, Campbell, CA 95008.

*UNIX is a trademark of Bell Laboratories
Z8 and Z80 are registered trademarks of Zilog, Inc.
Z800 and Z80,000 are trademarks of Zilog, Inc.

Zilog
an affiliate of
EXXON Corporation

Pioneering the Microworld

CIRCLE 137

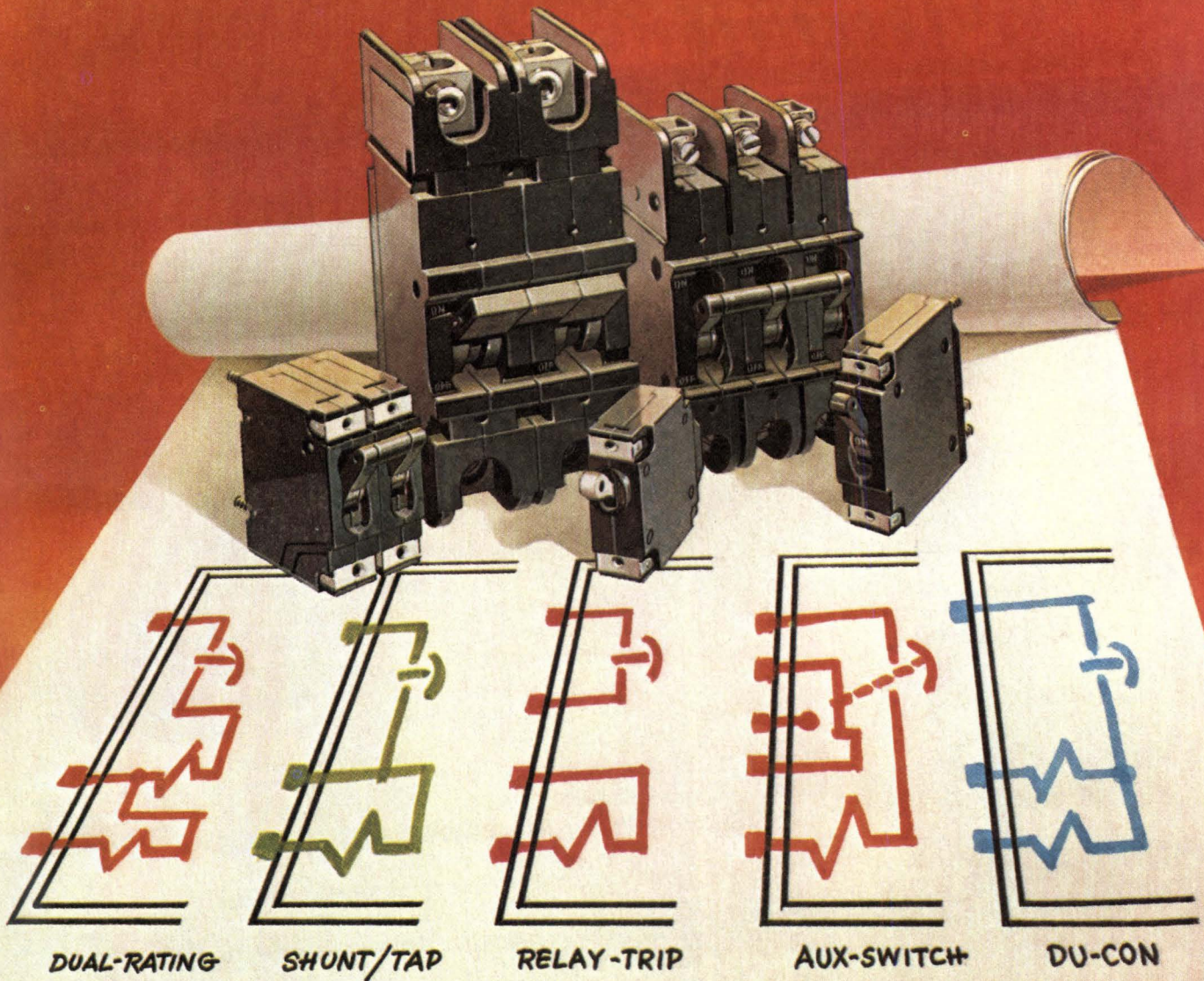

DUAL-RATING

SHUNT/TAP

RELAY-TRIP

AUX-SWITCH

DU-CON

Sweethearts.

From the outside, they look like the breaker-next-door. Inside, they steal designers' hearts.

Heinemann's special-function internal circuits add new flexibility in control and protective applications, to let designers pare component count, and spare design effort. Available in most of our standard series of precision magnetic circuit protectors, these configurations add to or alter the normal protective function, creating new approaches to circuit design.

Save design time; save cabinet space. With Heinemann's options, you can

open the load circuit with a separate control signal (voltage or current, isolated or derived from the line supply). Or trip on command with a separate contact closure. Or protect two loads with the same breaker, while only the load you choose will trip the breaker on overcurrent.

You can activate logic functions, lights, alarms, or you name-it, with isolated auxiliary switches tied to the breaker mechanism. Or spec a breaker with two current ratings, for extra

flexibility in equipment made to operate in different voltage systems or different countries.

Whether you want to simplify your design (and design effort), or cut a few precious centimeters of space from your package, Heinemann has the combinations you're looking for.

Request Bulletin 8101.

We keep you out of trouble.

HEINEMANN ELECTRIC COMPANY

P.O. Box 8428, Trenton, NJ 08650, U.S.A.
Phone (609) 882-4800 • Telex 843431

WHEN THE CHIPS ARE DOWN

All too frequently in the computer industry, conventional wisdom proves unwise. For example, just a few short years ago, it was often said that most semiconductor companies would willingly give away microprocessor chips if they could be assured of getting the subsequent orders for memory chips to go with them. Yet, today we find that some personal computer manufacturers may go out of business because they cannot get enough of the popular microprocessor chips, such as the Intel 8088 or 80186. Also, some processor chips (eg, the 8051) are in such tight supply that they go for as much as \$200 each in the clandestine "gray market."

Commenting on the present situation, Jack Scanlon, a vice president of AT&T Western Electric, joked in his keynote address at the recent Comdex Fall '83 exposition in Las Vegas, "This is the last place on earth where chips are not only in ample supply, but seem to maintain the same price for longer than 24 hours." Obviously, something not so funny happened on the way from yesterday's market projections to today's reality. Actually, several things happened—some predictable and some quite unpredictable.

The first problem with the early market projections was that they were extrapolated from a mainframe computer experience in which each CPU worked with enormous amounts of memory. Shorter wordlength microprocessors, however, were able to directly address much less memory. Also, bit densities of memory chips climbed rapidly in accordance with "Moore's Rule." Thus, fewer chips were needed for a given amount of storage capacity. Furthermore, Japanese semiconductor manufacturers (perhaps spurred by the bullish market projections) decided to target the RAM chip market, and glutted the world with inexpensive memory chips.

On the processor side, the problem was caused primarily by IBM. That company's use of Intel processor chips in its personal computers, coupled with its equity investment in the chip supplier, made the 8088 a *de facto* standard almost overnight—competing computer manufacturers rushed to share the market dominance promised by the IBM PC. There were few alternative sources for the Intel chips because other semiconductor manufacturers were either promoting their own designs or could not afford the required capital investment in the midst of a semiconductor industry slowdown. After the surge in demand for the 8088, other Intel processors also became scarce—the 80186 because it offered higher performance in personal computers, and the 8051 because it was made on the same fabrication lines as the 8088.

Of course, Intel will be expanding its output while other suppliers, such as Advanced Micro Devices, will offer alternative sources and expand their production capacity. Yet, the inevitable correction of the supply/demand imbalance may come too late to save many of the companies now jostling for the limited number of positions on the computer store shelves.

It would appear, therefore, that—in an industry where the stakes have become so high—there is an urgent need for better market research. No longer can research merely state the obvious or extrapolate from past experience; rather, it must explore various scenarios. To put it another way, Murphy's Law may not always prevail, but that is probably the way to bet.

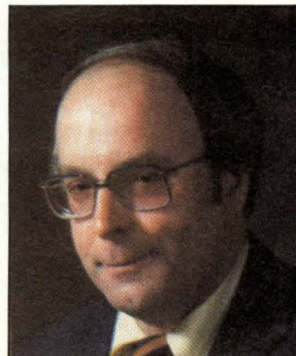

Michael Elphick
Editor in Chief

**In 16K static RAMs, INMOS
choices...starting**



means high-performance with 35ns access times

When you're looking for top memory performance in your system, look to today's leading supplier of high-speed static RAMs...INMOS. Because INMOS gives you a choice of speeds, organizations, power dissipation and packaging. Which means you can optimize your designs, without compromising on cost or performance.

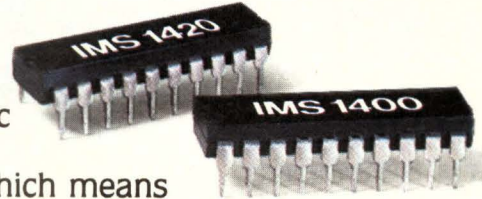

High speed. The INMOS family of fast static RAMs deliver access times of 35, 45, and 55ns. Perfect for high-performance tasks such as buffer memories, graphics, and main-store memory. And they give you a low-cost alternative to expensive 35ns ECL parts. Choose our by-1 organization for deep memory. Or the by-4, which also offers versions with 30 and 40ns chip-select access times, for writeable control store and cache memory. Most versions are available in plastic DIPs, ceramic DIPs, and chip carriers.

Low power. For high performance combined with low power, INMOS offers plastic packaged SRAMs with 70 and 100ns chip-enable access times in by-1 and by-4 organizations. Both have maximum power dissipation of 495 mW active, 83 mW standby. The by-4 organization is also a better alternative to 2Kx8 SRAMs in many high-speed applications. Best of all, they're both low cost. Here's your answer for fast systems that are power critical and price conscious.

Military versions. When you need fast RAMs you can trust in hostile environments, INMOS can supply 55 and 70ns parts with specs guaranteed over the full military temperature range of -55°C to 125°C. These parts, available in side-brazed ceramic DIPs, chip carriers, and flat-paks, conform to MIL-STD 883B processing, including screening to class B Method 5004 and quality conformance to Method 5005.

Check the chart. With all these choices, it's easy to see why INMOS is the leading high-speed RAM supplier. Look for the part you need, then call an INMOS distributor for complete details.

Organization	Speed (ns)	Power (mW)		Part No.
		Active	Standby	
16K x 1	35	660	110	IMS1400-35
	45	660	110	IMS1400-45
	55	660	110	IMS1400-55
	70	495	83	IMS1400-70L
	100	495	83	IMS1400-10L
4K x 4	45	605	165	IMS1420-45
	55	605	165	IMS1420-55
	70	495	83	IMS1420-70L
	100	495	83	IMS1420-10L

INMOS Distributors:

Anthem Electronics, Arrow Electronics,
Future Electronics, Lionex Corp., RAE



P.O. Box 16000 • Colorado Springs, Colorado 80935 (303) 630-4000
TWX 910/920-4904 • Burlington, Mass. (617) 273-5150 •
San Jose, Calif. (408) 298-1786 • Torrance, Calif. (213) 530-7764 •
Minneapolis, Minn (612) 831-5626 • Baltimore, MD (301) 997-2947 •
Whitefriars • Lewins Mead • Bristol BS1 2NP • England
Phone Bristol 0272 290 861 • TLX: 444723

inmos.  and IMS are trademarks of INMOS' Group of Companies.

CIRCLE 8

RSX & RT-11 USERS: Share host resources with remote stand-alone processors.

Call today. Learn how Computrol Megalink communications systems form local area networks and create virtual disk storage for remote sites.

- No disks needed on RSX-11M/S or RT-11 remotes.
- RSX and RT remotes can share same disk/printer resources.
- High speed 1 Mbps LAN, high data integrity.
- Automatic bootstrap load.
- Optimized for real-time response.
- 32 remotes over 6 mile coaxial cable.
- Megalink DMA interfaces for Unibus, Q-bus and Multibus.

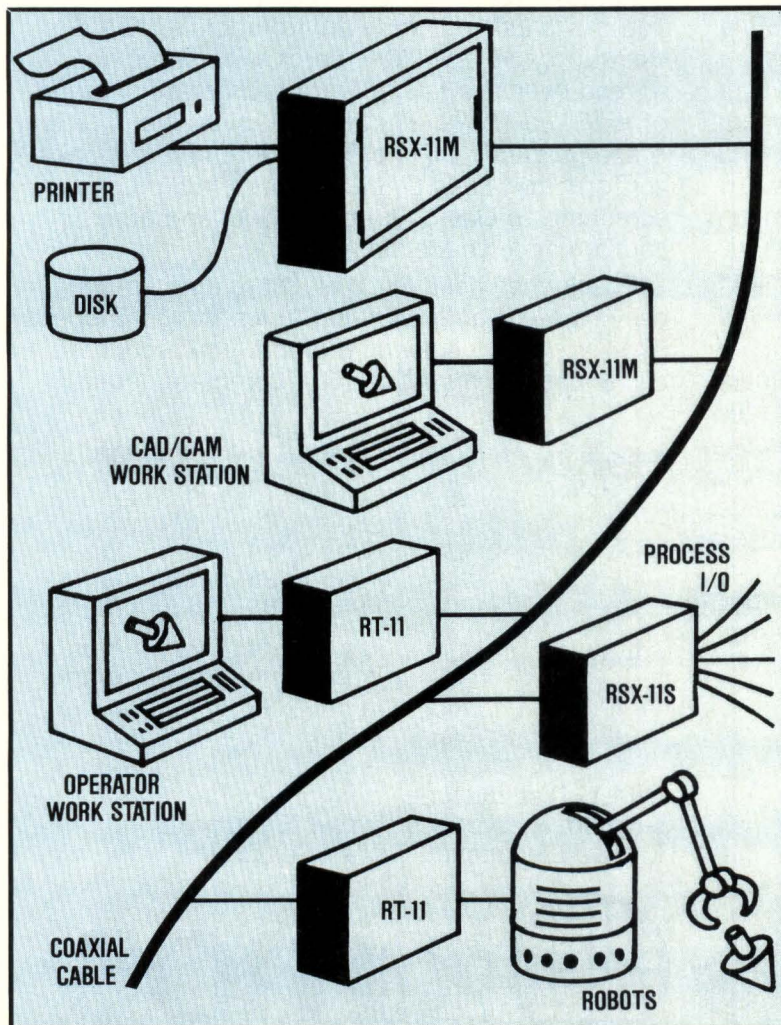

Call Ken Still today: (203) 544-9371

COMPUTROL

Division of Kidde Automated Systems, Inc.

KIDDE

15 Ethan Allen Highway/Ridgefield, CT 06877-6297 / (203) 544-9371

COMPUTER DESIGN

Editor in Chief, Michael Elphick
Managing Editor, Sydney F. Shapiro
Senior Editors, John Bond
Peg Killmon

Senior Associate Editor,
Deb Highberger

Associate Editor, Malinda E. Banash

Chief Copy Editor,
Leslie Ann Wheeler

Copy Editors, Helen McElwee
Lauren A. Stickler
Jack Vaughan

New York Field Office

Senior Editor, Nicolas Mokhoff

Special Features Editor,
Harvey J. Hindin
230 Park Ave, Suite 907,
New York, NY 10169,
Tel: 212/986-4310

Western Field Offices

Managing Editor, Tom Williams

Field Editor, Sam Bassett
540 Weddell Dr, Suite 8,
Sunnyvale, CA 94086,
Tel: 408/745-0715

Field Editor, Joseph A. Aseo
331 Freeway Center Bldg,
3605 Long Beach Blvd,
Long Beach, CA 90807,
Tel: 213/426-1172

Publisher, Gene Pritchard

Marketing Director,
Robert A. Billhimer

Circulation Director,
Robert P. Dromgoole

Production Assistant, Philip Korn

Ad Traffic Coordinator, Ginger Rhoads

Design Coordinator, Lou Ann Morin

Technical Art, Designline

PennWell
PUBLISHING COMPANY

Advanced Technology Group
119 Russell Street,
Littleton, MA 01460
Tel: 617/486-9501

H. Mason Fackert,
Group Vice President

Saul B. Dinman, *Editorial Director*

David C. Ciommo, *Controller*

Steve Fedor, *Promotion Director*

Linda G. Clark,
Marketing Services/PR Manager

Linda M. Wright, *Production Director*

Wanda Holt, *Data Services Manager*

Pat Armstrong,
Administrative Services Manager

Put a little tape backup in your DEC microcomputer.

SMS' DSX-11 is a complete DEC microcomputer with 80Mb Winchester and 1/4" cartridge tape backup. With over 20Mb per tape cartridge, Winchester backup has never been so easy. Emulating DEC's latest TS11 tape device, standard RT-11 and RSX-11M software makes disk backup, system boot, media interchange, archiving and software distribution a snap!



256Kb main memory (expandable 4Mb)

Expansion space for 15 dual height modules.

LSI-11/23 16 bit CPU with memory management.

4 Serial ports.

Advanced disk controller with ECC, flaw management, bootstrap, error retry and non-interleaved data transfer.

PDP-11* architecture compatible with RT-11, RSX-11M and UNIX** software.

17.8Mb, 35.6Mb or 71.2Mb Winchester disk.

Self test with LED display of system faults.

Start/stop tape supports file operations.

Compact 3M Cartridge.

TAPE CONTROLLER ONLY AVAILABLE FOR VOLUME REQUIREMENTS.

SMS
**Scientific Micro
Systems, Inc.**

777 E. Middlefield Road
Mountain View, California 94043
(415) 964-5700

AUTHORIZED SMS DISTRIBUTOR FOR DEC
Q-BUS PRODUCTS: FIRST COMPUTER
CORPORATION (312) 920-1050

SMS SALES OFFICES:

Phoenix, Arizona (602) 978-6621;

Boston, MA (617) 246-2540; Atlanta, Georgia

(404) 296-2029; Morton Grove, Illinois (312)

966-2711; Yorba Linda, California (714) 993-3768.

* Trademark of Digital Equipment Corporation. ** Trademark of Western Electric.

CIRCLE 147



KeyTronic's SCREENED CONTACT™ Keyboard

This full-travel keyboard technology is the solution for any manufacturer who needs a keyboard without electronics.

- Rated at 50 million operations.
- Top-sealed.
- No silver traces or gold contacts.
- Does not utilize a printed circuit board.
- Low Profile (19 mm high at home row).
- Keys and key arrangement designed to your specifications.
- On-time delivery to your plant.
- Experienced personnel to service your account.

Key Tronic will respond to your manufacturing needs with our efficient people, quality products and in-house manufacturing capabilities.

Call your Key Tronic representative today.



THE RESPONSIVE KEYBOARD COMPANY

P. O. BOX 14687 • SPOKANE, WA 99214 U.S.A. • PHONE (509) 928-8000 • TWX 510 773-1885

CIRCLE 11

LETTERS TO THE EDITOR

More on CAE workstations

In his May 1983 Computer Design editorial, "We've Seen the CAD—Now Let's See the CAE," Saul Dinman (then Editor in Chief) asked users and prospective users of engineering workstations for comments and relevant experiences. Here are some of the answers:

I want it all! Schematic capture, digital and analog simulation, local floppies (1 Mbyte), network capability, mail, remote files, plotters, printers, high speed, color graphics, PC layout, and gate array packages.

R. B. O'Hara
Fairchild Space & Electronics
Germantown, Md

Amen! We have purchased systems and software for design purposes and have been both pleased and disappointed with the products. Now we are looking for a CAD/CAM system for drafting, schematic design, and the ability to lay our PC boards onto clear Mylar for direct production.

Barry Larsen
Gemco Electric
Clawson, Mich

Working on system engineering of complex systems requires very frequent preparation of system diagrams and brief notes or explanations. The diagrams get changed frequently, but ultimately the products are briefings, memos, and technical reports. An engineering workstation that has easy-to-use graphics and word processing capability would be very useful. The engineering workstation would be accessible by other engineers, secretaries, and graphics personnel to convert draft material into final form. Workstation access to current and predicted project cost data would also be useful. Some of these techniques are now being used.

J. H. Selander
Mitre
McLean, Va

Only the logic simulation is of help to the engineer. The rest of the features are just a means of automating the data documentation. If the test pattern generation or the running of the simulation is inconvenient, the CAE station will not be used. "Using a computer should be easier than not using a computer."

S. Young
Interstate Electronics
Anaheim, Calif

We are following, with very high interest, the CAE development and market. We read all the details about hardware, software, and prices. I also dream about low

price systems aiming to micros opening the windows, picking the information from the libraries, and concentrating to the flow of the circuit. I would really buy the components one by one and put the system together. How can I get the software? Help.

Dezso Fokos
Hughes Aircraft Co
Irvine, Calif

Any workstation should be able to access the data base created by the drafting function. This base should include schematics, PC layouts, bills of material, weldments, assemblies, etc. Using this base, the engineer can perform analyses of circuits, structures, and temperatures without having to reenter basic information on the design of the subsystem. The workstation operator should only be required to know about 25 commands to operate the system on the existing design data base.

Frank Luteran
Weston Controls
Archbald, Pa

I work with a university research environment—designing research computers. However, the greatest problem faced is that of design documentation. The greatest boost to my productivity would be a high resolution graphics personal workstation to provide editing functions on both word and drawing documents. I believe my productivity would increase by at least 100 percent with even modest CAD software tools.

Prof D.M. Koch
Monash University
Clayton, Australia

Here we have a small number of workstations due to the "closed market" in our country that prohibits the importation of such equipment, or reduces it. In our factory, we have a Gerber CAD and we're using it for mechanical and drawing design. We're still in the beginning with printed circuits due to missed information. I personally use a TRS-80-like micro in my home technical affairs. We need more knowledge in the CAE area to get to use such stations.

Enrique Ferri
Industrias Villares SA
Sao Paulo, Brazil

What bothers me most, and the reason for not buying a microcomputer yet, is the lack of support for a Fortran compiler with which quick enough response can be obtained. Key application is mostly scientific data processing and simulations, and I have to limit myself to mainframe or large minicomputer systems.

Mario Y. Atias
Aerotec Consultants
Petah Tikva, Israel

More details of other companies' experiences/benefits will be needed before certain companies ever consider the "workstation/engineer" approach. A great number of functions will be covered by a good graphics and scientific S/W system.

N. J. Tebble
Marconi Avionics Ltd
Welwyn Garden City, England

I was very much impressed by a recent announcement that Simulation Sciences will place its PROCESS—Process Simulation Package (Steady State)—on an HP 9000 desktop minicomputer. Our engineers have used this package for years—on various IBM machines in a time-sharing mode (TSO, etc). This has been less than satisfactory from the user's point of view due to delays in log-on, slow turnaround, etc. However, the PROCESS package is useful so they persisted in using it. The point of all this is that engineers will be delighted to use an engineering workstation as long as it is sufficiently large enough to accommodate software that is useful to them. With the HP 9000 desktop, this breakthrough has been achieved.

George A. J. Homolka
Arabian American Oil
Ran Tanura via Dhahran, Saudi Arabia

There is a need [in CAE] for microcomputer software (IBM PC, Apple) that combines text editing, graphics, circuit simulation (digital and analog), etc, in the realm of electrical engineering.

(continued on page 22)

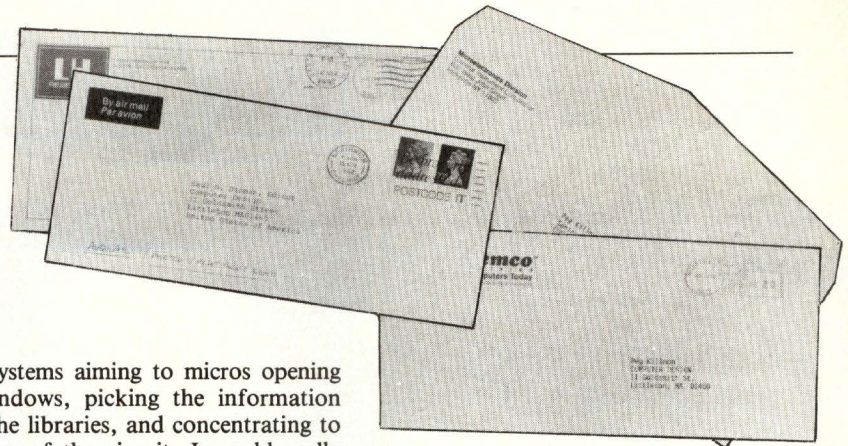

STAY OUT OF THE

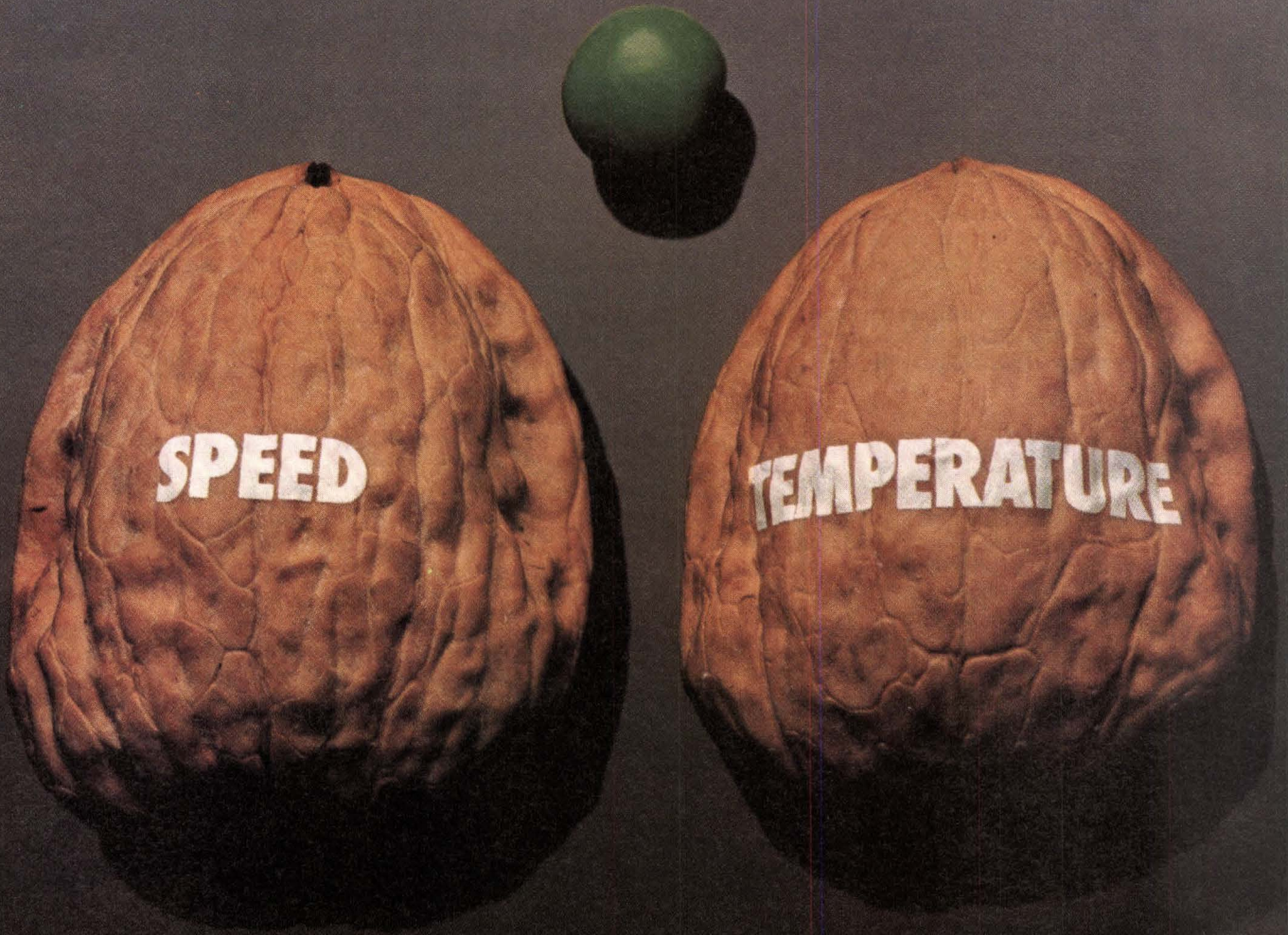

GUARANTEE GAME.

It's easy to spot the "now-you-see-it, now-you-don't" guarantee.

It guarantees function, but not at speed. Or speed and function, but not at temperature. While you're looking at one part of the guarantee, another part moves, changes, vanishes.

And that can be a very expensive game.

Better talk to Advanced Micro Devices. We're the folks with the long suit in quality and the short guarantee.

No ifs. No ands. No buts.

The International Standard of Quality guarantees a 0.1% AQL on all electrical parameters over the entire operating range.

INT-STD-1000



Advanced Micro Devices 

901 Thompson Place, P.O. Box 3453, Sunnyvale, CA 94088
(408) 749-5000, outside California, call toll free (800) 538-8450, ext. 5000.

**DO YOU HAVE
THE DRIVE
TO SUCCEED?**

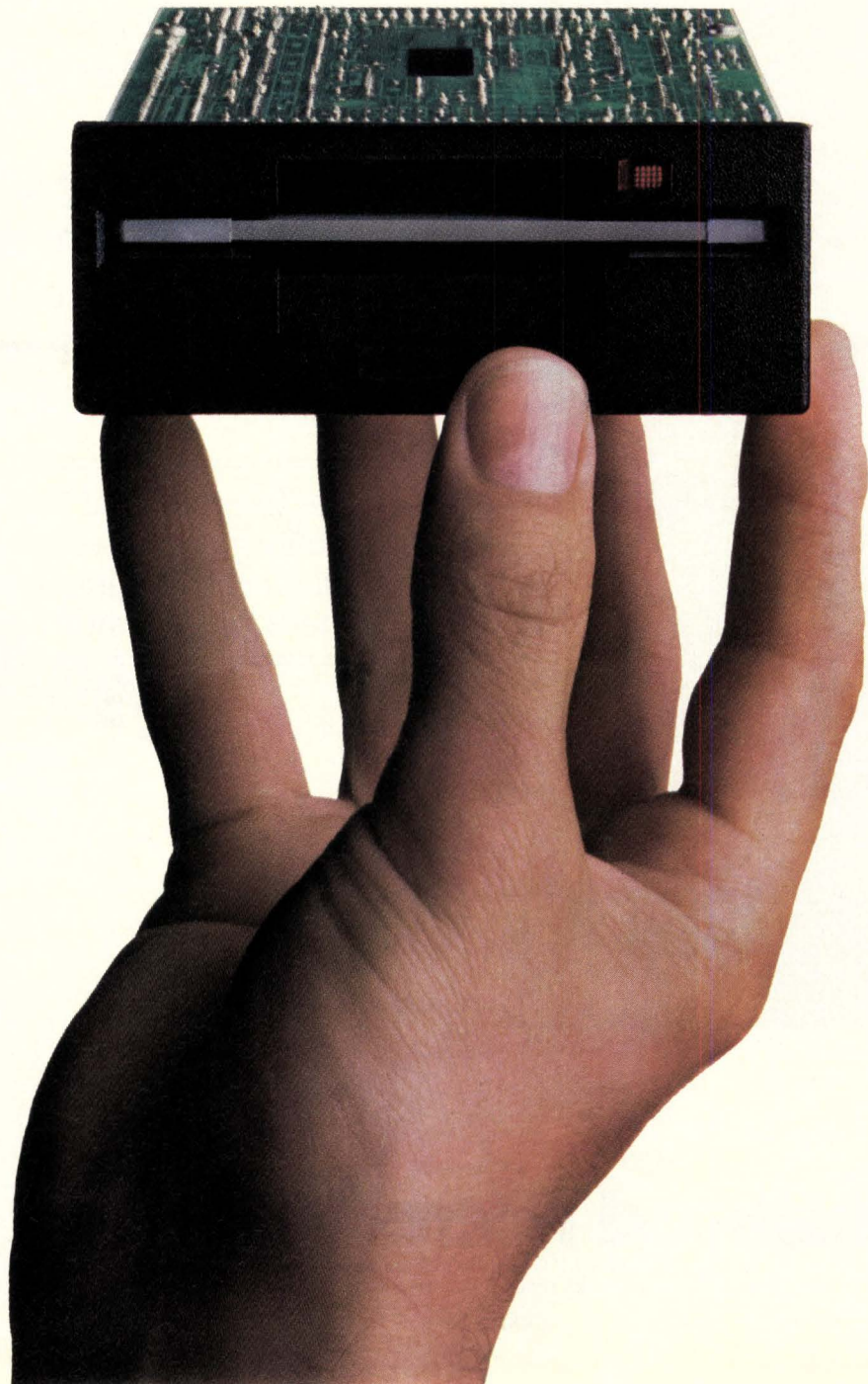

You do?

Good. So do we.

Shugart's 3.5" microfloppy drive. The SA300 by name.

And, considering where the personal/home/portable computer market is headed (betterfastercheapersmallerwithmorestorage), it's not a moment too soon.

It's also quite an achievement. One that allows you to engineer a wealth of advantages into smaller, more competitive systems.

Take the most obvious advantage, for instance.

Size. With the SA300 you can make your personal and home systems less imposing, more, well, personal. Our microfloppy takes up 75% less room than a standard sized Minifloppy.™

And it weighs just a tad over a pound. So your portable system can be more, you guessed it, portable, even with two drives in it.

Yet the SA300 still delivers 500 Kbytes in the single-sided version (1 Mbyte in the double-sided version) and uses less power, worst case, than an 8-watt night-light.

It's also so quiet, you can't hear it running unless you put your ear right down on top of it.

And with an MTBF of over 10,000 power-on hours, it should run for quite some time.

Then, of course, there's the not-so-small matter of the industry standard 3.5" microfloppy diskette.

Which offers a few important advantages of its own.

Like Minifloppy compatibility.

A track density that allows room for a generous upgrade path to more capacity.

And a hard shell plastic media cartridge for protection against the rigors of pocket and purse, with an automatic head access shutter as a last line of defense against little computer users who eat a lot of peanut butter and jelly.

Want to learn more?

We'll do a private Micro-floppy Workshop right in your office. And you'll have the chance to talk with media manufacturers and our own applications engineers about your plans for a big design win.

Call your local Shugart Sales Office to set it up. But do it soon.

You'd be amazed at what you can do with a little drive.



The 3.5" Micro-Cartridge provides maximum media protection.

Shugart

Right from the start.

Assault & Battery.

(The costs could cripple you.)

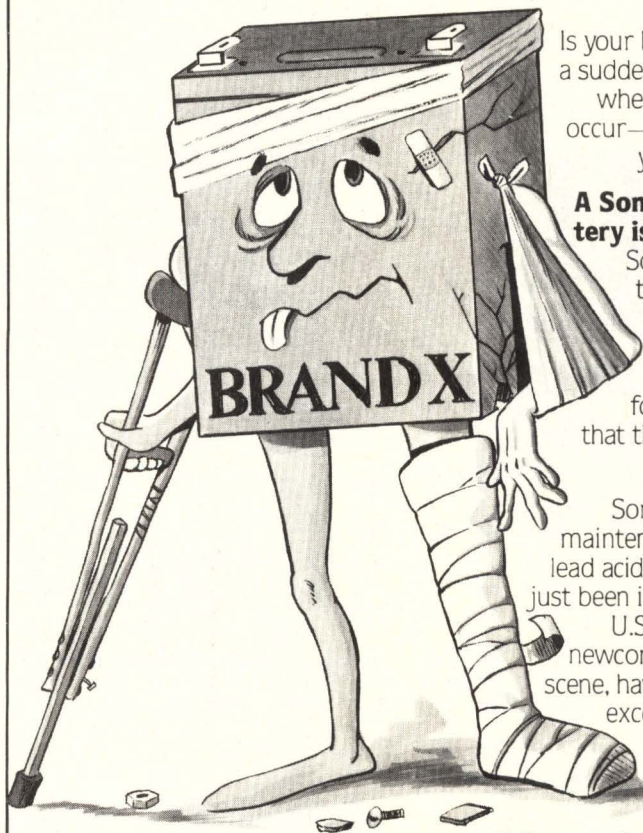

Is your battery ready for a sudden power demand when power outages occur—after 3, 5, 7, 10 years on the job?

A Sonnenschein battery is always ready!

Sonnenschein batteries have such a low rate of self-discharge and such high performance on float that they will be ready for any assault!

Sonnenschein is the maintenance-free sealed lead acid battery that has just been introduced to the U.S. market. It is no newcomer to the world scene, having produced in excess of 20 million batteries.

All models available from U.S. stock. Send us your application and see what a Sonnenschein will do for you. 1Ah-1350Ah. 2-12 V.

Write for our 24 page dryfit Brochure with all the details.

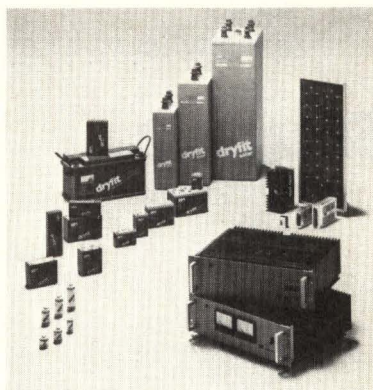

Sonnenschein

Sonnenschein Batteries Inc.

537 New Britain Avenue
Unionville, Connecticut 06085
(203) 677-5846

Please send me your DRYFIT Brochure.

Name _____

Address _____

City _____

State _____

Zip _____

Application _____

Meets NATO Military specifications.

LETTERS TO THE EDITOR

(continued from page 17)

Unfortunately, most of the match software does not have the ability to conveniently deal with complex numbers, if at all. I need to develop models, store them, combine them, excite them, and display the resulting steady state and/or response, etc.

Phillip Cutter
Orange Coast College
Costa Mesa, Calif

Bubble memories do have benefits

Deb Highberger's Fall 1983 article, "Sizing Up 16-bit Portable Computers," included a lot of good information in this exciting new product area. However, I must comment on Mr Mitchell's statement, "I think that [CMOS SRAM] is going to win out over bubble and everything else," found on p. 56.

Bubble memories operate at a fraction of the power requirements for floppy disks or Winchester. And, with proper techniques, bubbles approach the power consumption of CMOS RAM, with standby current below 20 mW. This certainly makes bubbles suitable for battery-operated portables. Add to that bubble memory's high density, solid state reliability, and lower cost per bit than CMOS RAM both today and for the foreseeable future, and it is clear that bubbles have an important future in portable computers.

In fact, *Computer Design* could do its readers an important service by further educating them in the significant features bubble memory can bring to a microcomputer system.

Michael W. Eisele
Intel Corp
3065 Bowers Ave
Santa Clara, CA 95051

Another 32-bit chip set

In Sam Bassett's article, "Microprocessors: Speed Up, Price Down, and CMOS Everywhere," (Oct 1983) there was an erroneous statement. On p 186 under the subhead "On the horizon," Mr Bassett claims that "The only 32-bit chip set currently on the market is Intel's three-chip 432 architecture."

NCR Corp's Microelectronics Div is producing, and has been sampling since July 1983, a full 32-bit chip set—the NCR/32 microprocessor family. The NCR/32 provides new VLSI mechanisms for offchip microcoding, instruction-set partitioning, and microcode primitives.

Mary Anne Ryan
NCR Corp
1635 Aeroplaza Dr
Colorado Springs, CO 80916

NS32032

The First True
32-Bit Microprocessor
to Become Reality.

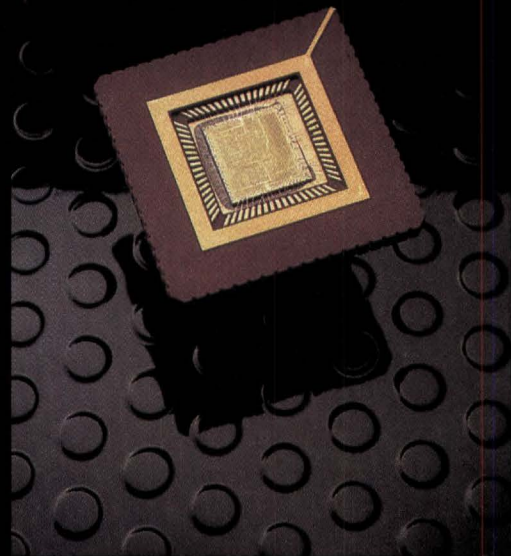

NS32032

*The first commercially available
microprocessor to feature:*

- 1. Full 32-bit architecture*
- 2. Full 32-bit internal implementation*
- 3. Full 32-bit data bus to memory*

The industry's consensus: with the introduction of the NS32032, the NS16000™ microprocessor family has become the foundation for the next generation of high-performance, low-cost computers.

Any software developed for the 32-bit NS32032 will run just as well on the 16-bit NS16032 or the 8-bit NS08032, and vice-versa. And it will also run on future NS16000 32-bit CPUs. Consider this absolute *downward-upward* object code compatibility in contrast to the *upward-only* compatibility of other microprocessor families, which will make their 16-bit processors obsolete when they add 32-bit processors to their product line.

The NS16000 microprocessor family already includes peripherals compatible with its CPUs, and each is in full production: the NS16201 Timing Control Unit (TCU), the NS16202 Interrupt Control Unit (ICU), the NS16081 Floating Point Unit (FPU), and the NS16082 Memory Management Unit (MMU). Since the FPU and MMU interfaces are almost entirely invisible to NS16000 programs, the decision to include or omit floating point or memory management hardware (for cost/performance reasons) will not affect NS16000-based systems' software compatibility.

The billions of bytes of existing mainframe software can now be easily ported to run on NS16000-based systems. The NS16000 family's mainframe-in-silicon architecture (designed specifically to support high level language programming), its full high-speed floating point arithmetic capability, its integral support for Demand Paged Virtual Memory, and the NS32032's 32-bit data bus to memory combine to make this possible for the first time.

Elegance, you see, is everything.

Think about it.

The only limits on NS16000-based applications are those of the imagination.

The full 32-bit architecture of the NS32032 (shared by all NS16000-family CPUs) sets no bounds to programmers' productivity or creativity.

No other processor family—micro, mini, or mainframe—has an architecture designed to fully support the use of high level languages, with a structure and behavior corresponding directly to the objects and operations of HLLs.

Its powerful features:

- A compactly encoded, completely symmetrical, two-address instruction set.
- Thirteen addressing modes (many not found in other microprocessors) designed for the kinds of accesses compilers generate.
- Indexing automatically scaled to argument size (1, 2, 4, or 8 bytes), applicable to any addressing mode.
- Instructions to implement high level language constructs such as case statements, loops, and calls, as well as bit-field and string manipulation.
- A fully integrated floating point instruction set, supported by hardware.

The 32-bit architecture of the NS32032 (like that of the other NS16000 CPUs) is fully implemented, without exception or restriction.

Simply stated, physical limitations in processing or packaging technology have not constrained internal implementation. All NS16000 CPUs have a full 32-bit Arithmetic Logic Unit (ALU), a full 32-bit register set, and a full 32-bit internal data bus to the input/output control block.

The value of such elegant implementation? An example: competitive microprocessors take eight to twenty internal steps to execute the expression evaluation "A = A * X + Ai," commonly used in high-performance technical and scientific applications.

The NS32032 takes four.

The NS32032's full 32-bit data bus to memory increases memory bus bandwidth—and thus the speed at which data can be transferred.

In simple systems (CPU and memory), the NS32032's ability to access a full 32 bits of external data dramatically increases the rate at which instructions and data are processed, while leaving bus time available for system peripherals.

Because it requires less than 50% of the available bus bandwidth in standard applications, the NS32032 is also ideally suited to complex multi-processor systems, DMA transfers, and high-speed graphics.

In the NS16000 family of CPUs, the primary feature that distinguishes one processor from another is the width of the data bus to memory.

The fact that the NS08032 and the NS16032, with their 8-bit and 16-bit data buses, share identical 32-bit architecture and 32-bit implementation with the NS32032 means that it is now possible to develop 8- and 16-bit systems with all the benefits of 32-bit software performance. The same software can now be implemented on all the systems within a product family; an enormous benefit to programmers and systems designers.

Future 32-bit CPUs planned for the NS16000 family will feature improved performance—bettering the NS32032's 1 MIPS tenfold by 1988—yet these future CPUs will also be compatible. This clear migration path guarantees the preservation of your initial software investment while providing for significant enhancement in your product line.

No other family of microprocessors shows such forethought or foresight.

TYPICAL EXECUTION TIMES (in μ s at 10MHz)

Instruction	Register-to Register	Memory-to-Memory		
	NS08032 NS16032 NS32032	NS08032	NS16032	NS32032
Mov Byte	0.3	1.7	1.7	1.7
Word	0.3	2.5	1.7	1.7
Dbl.word	0.3	4.2	2.6	1.7
Add Byte	0.4	2.0	2.0	2.0
Word	0.4	3.2	2.0	2.0
Dbl.word	0.4	4.7	2.3	2.0
Mul Byte	3.8	4.3	4.3	4.3
Word	5.4	7.0	5.8	5.8
Dbl.word	8.6	12.0	9.6	8.4

Additional reasons why the NS16000 family now leads in microprocessor design-wins:

1. *Hardware development can begin immediately.* All three CPUs are available right now. So are all the necessary peripherals in the family.

2. *Software development can begin immediately.* Appropriate evaluation tools, and both resident- and cross-support packages, are available now, as is an extensive list of third-party software.

Our SYSI6™—a multi-user, multi-tasking development system—incorporates the complete family of NS16000 chips (CPU, TCU, ICU, FPU, and MMU), and therefore gives up to eight programmers a true, native environment to work in.

GENIX™, a product of our software engineering group, is the first microprocessor operating system capable of implementing Demand Paged Virtual Memory.

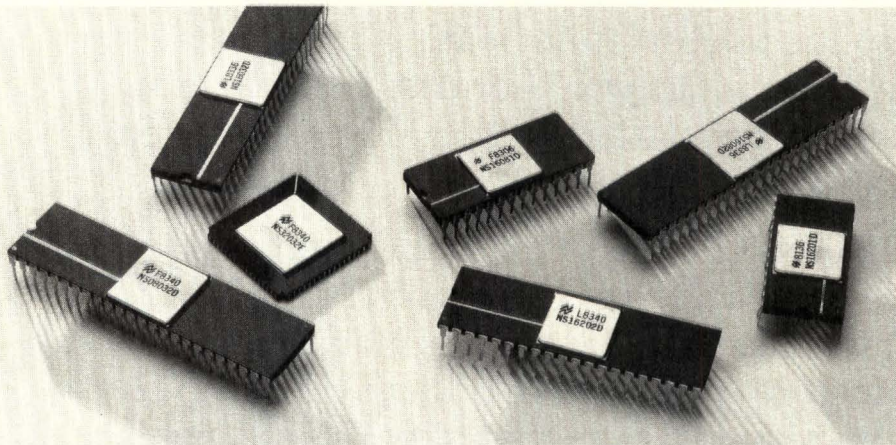

The NS16000 microprocessor family.

Adapted from the Berkeley 4.1 bsd version of UNIX,[™] it has been elegantly tailored to optimize the NS16000 architecture. (We also offer source code under license for GENIX and its utilities.) Together, the SYS16 and GENIX demonstrate that the NS16000 microprocessor family makes the best "UNIX engine" on the market today.

For customers with VAX-11[™] systems under UNIX, our GCS[™] (GENIX Cross Software) contains the C compiler and other NS16000 tools from the SYS16. For VAX-11 systems running the VMS[™] operating system, our NSX-16[™] cross software provides full NS16000 family support.

To help complete your development cycle simply and quickly, all of our development tools provide support for our easy-to-work-with ISE/16[™]. An elegant development tool in its own right, the ISE/16 allows real-time evaluation of the NS16000 chips, for testing and debugging hardware and software in your own hardware environment, and requires no target-system modification.

3. Every resource imaginable to help you get your NS16000-based application to market first is available now. We are totally committed — with in-house hardware, software, and systems expertise; with service, documentation, and customer training. We are backing the NS16000 microprocessor family to a degree unparalleled in the history of the semiconductor industry.

But then, there has never been anything like the NS16000 microprocessor family before.

VAX and VMS are trademarks of Digital Equipment Corporation.
UNIX is a trademark of Bell Laboratories.
NS16000, SYS16, GENIX, GCS, NSX/16, and ISE/16 are trademarks of National Semiconductor Corporation.

NS16000

Elegance is everything.

See it.

The NS16000 microprocessor family will be on exhibition at *Uniforum* and *Electro*.

Talk with us.

Please call the National Sales Representative nearest you for more information, and the answers to your questions. Ask to meet with one of our Field Applications Engineers, too. Or, circle the number below.

Read about it.

For more information, please request a copy of NS16000: *The Specifics of 32-Bit Architecture*. And for practical experience, ask for a copy of NS16000 *Training*, detailed information on available courses.

NS16000:
The Specifics
of 32-Bit
Architecture

NS16000
Training

 **National Semiconductor Corporation**

MICROCOMPUTER SYSTEMS DIVISION

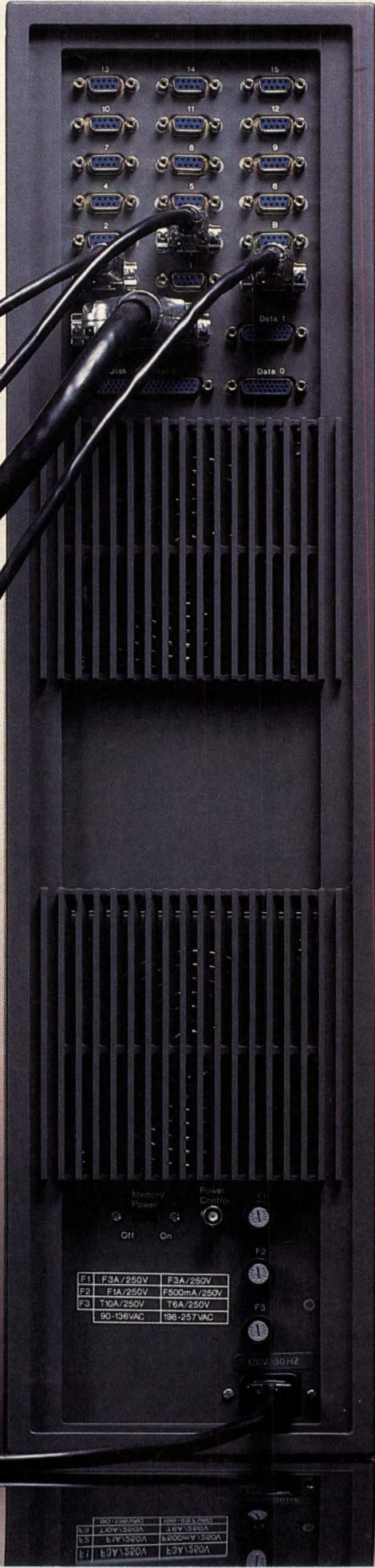

F1	F3A/250V	F3A/250V
F2	F1A/250V	F500mA/250V
F3	T10A/250V	T6A/250V
	90-135VAC	198-257VAC

F1	V08S1A83	100V 50HZ
F2	V08S1A83	100V 50HZ
F3	V08S1A83	100V 50HZ

TOWER 1632. YOU CAN REALLY GROW ATTACHED TO IT.

Tower™ 1632's nonproprietary peripheral connection flexibility is simply unsurpassed by any mini. Or micro.

Of course we offer an industry-standard bus, Multibus* IEEE-796. Of course we offer SA400, ST506, SMD and QIC II, so you can attach additional mass storage devices. And of course we support RS232C communications. ASCII TTY. And Bisync (2780/3780). Allowing Tower 1632 to connect and communicate with terminals, printers, mainframes, minis, personal computers and numerous special devices, from optical character and code readers to data tablet digitizers.

But our planning really pays off for you in our networking capabilities. Whatever standard you choose we can handle. From our UNET** peer network to SDLC/SNA, X.21/X.25, or Ethernet.***

Of course, we have a very good reason for offering all this flexibility. It's part of our commitment to providing OEMs with the prime requisite for success. A system built expressly for systems builders.

That's what we deliver. And that's the reason we tower over our competition.

Call us toll free at 1-800-222-1235 to learn more.

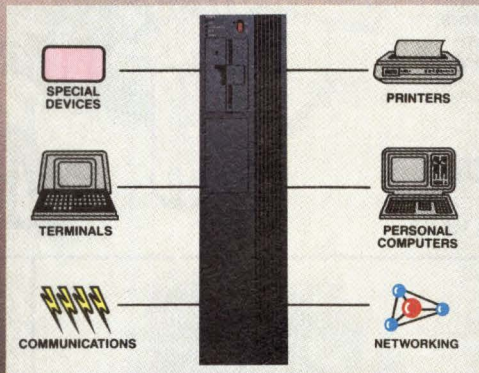

**BUILT FOR SYSTEMS BUILDERS.
TOWER 1632.**

NCR
OEM Marketing Division

NCR Corporation, World Headquarters, OEM Marketing Division, Dayton, OH 45479. Nationwide (800) 222-1235. In Ohio (513) 445-2380. In Canada (800) 268-3966.

*Multibus is a trademark of Intel Corporation. **UNET is a trademark of 3 Com Corporation. ***Ethernet is a trademark of Xerox Corporation.

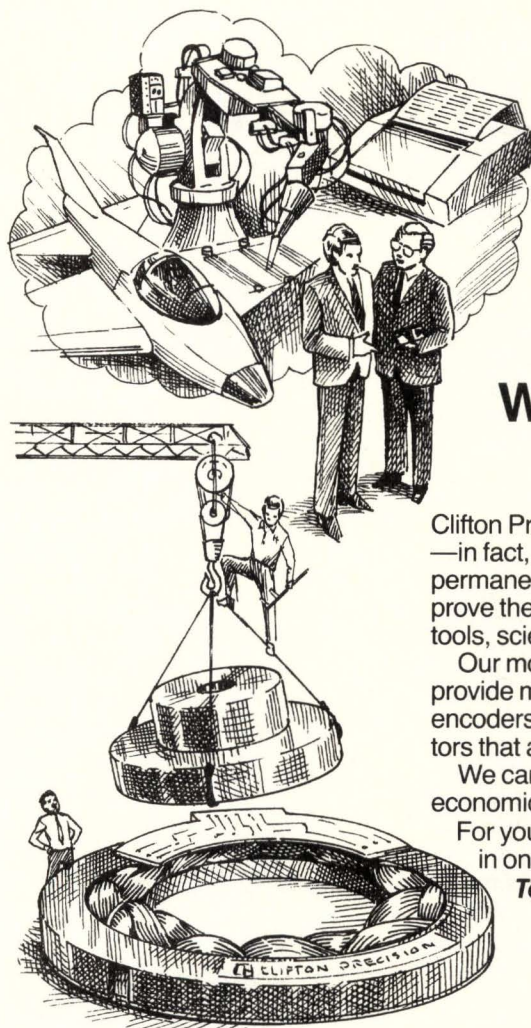

Let the Clifton team develop a special motor for you.

We'll build better performance into your product.

Clifton Precision designs and custom builds fractional horsepower motors—in fact, we produce the widest selection of stepper, brushless, torque, permanent magnet, and miniature motors in the industry. Motors that improve the performance of computer peripherals, robotic systems, machine tools, scientific instruments, and more.

Our motors are specially designed to meet your particular needs. We can provide matched motor-transducer units with feedback systems such as encoders, synchros, resolvers, and tachometers. And we also provide motors that are 100% tested for "Zero-Defect" and "Ship-to-Stock" programs.

We can build special small orders for your prototypes and we offer very economical large production runs.

For your next motor, give us a call. While everything we make is special in one way or another, at Clifton, the special is routine.

To discuss your motor application, call our motor experts. We respond.

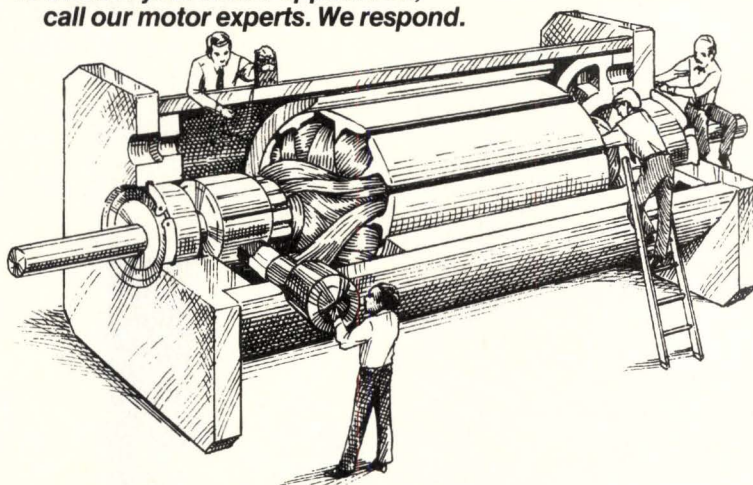

For stepper and commercial brushless dc motors, call Jim Chandler at Murphy, NC (704) 837-5115

For permanent magnet motors, torque motors, synchros, resolvers, and other rotating components, call Buck Wrenn at Clifton Heights, PA (215) 622-1000



CLIFTON PRECISION®

Marple at Broadway, Clifton Heights, PA 19018



Stepper Motors

From size 8 to 23; step angles including: .9°, 1.8°, 1.875°, 3.6°, 15°, 30°, 45° and 90°. Clifton's extensive selection offers high torque (to 170 oz-in) and accuracy to 3'. Can be provided as matched motor-encoder sets.

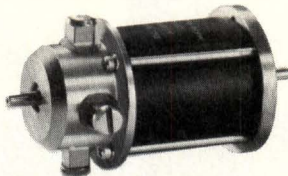

Permanent Magnet Motors

Frame sizes from 3/4" to 4". From ceramic-magnet, alnico-magnet, to rare-earth magnet designs, Clifton PM motors drive equipment ranging from computer peripherals, machine tools and robotics, to high performance missiles.

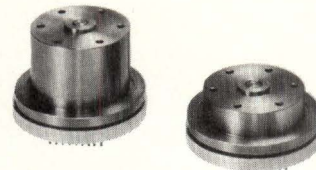

Brushless DC Motors

Available as housed units or rotor/stator sets. Clifton has one of the best track records for providing innovative, reliable designs that save production costs, save space, and provide the performance that critical computer peripheral, military, and industrial applications demand.

CIRCLE 148

CIRCLE 149

CIRCLE 150

For General Information Circle 151

Gallium arsenide chips shine where silicon versions fade

Plainly put—the world is running out of quicksand. That is, the chemical compound silicon, found in sand and currently the bedrock of ICs, is reaching its physical limits. Silicon cannot switch digital logic signals at ultrahigh speeds without evaporating from the resultant generated heat.

While silicon diehards are squeezing every nanosecond out of new IC designs, proponents of another IC material—gallium arsenide—are reaching cruising speeds in the picosecond range. In addition, researchers

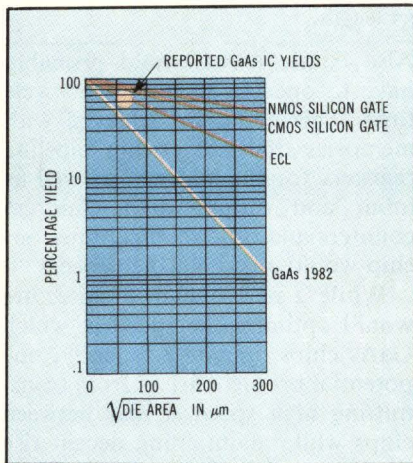

In comparing wafer probe test yields versus die size for various IC processes, GaAs yields for a small die size have been reported matching those of bipolar ECL.

are achieving these switching speeds with a smaller increase in power consumption than that of silicon-based circuits. As a result, prototype GaAs chips exhibit a smaller speed-power product than their commercially available silicon counterparts.

Until recently, the higher performance level of GaAs ICs could only be produced in insignificant wafer yields unacceptable for large-volume commercial production. Thus, applications for these chips were relegated to laboratory experimentation or very specific projects. Chips were being designed in areas where high speed was crucial for the operation of unique, sophisticated systems such as microwave-rf satellite receivers, military signal processors,

or medical image processors—all analog applications.

Recently, however, developments in GaAs technology have brought the technology to the forefront as a legitimate candidate for high speed digital applications such as supercomputers. Two major factors make this possible: modern silicon wafer production techniques are being used to dramatically increase GaAs wafer yields; and system engineers are concentrating their designs on applications for which GaAs digital chips are best suited. For the latter, second-generation high electron-mobility transistor (HEMT) technology will be instrumental in developing a GaAs VLSI computer that operates at ultrahigh speed and dissipates low power.

Reproducibility of good GaAs ICs is, of course, crucial to developing a supercomputer that exclusively uses GaAs circuits. To that end, one industry observer optimistically predicts wafer yields will approach those of silicon by 1993, or perhaps sooner. George Avery, of Technology Insight Consultants (San Jose, Calif), recently claimed that the same factors contributing to almost defect-free silicon chips will also play a key role in attaining better yields for GaAs ICs. Avery said this will happen at a faster rate than that achieved by silicon producers because “there is going to be a wealth of shared experience that will fall out of the silicon IC world in terms of equipment and techniques that can be applied directly to the gallium arsenide industry.”

Matching ECL yields

At a recent GaAs symposium in Phoenix, Ariz, Avery pointed out four reasons why silicon houses are now able to obtain consistent yields in the 80 to 90 percent range. These include improved contamination control, modern lithography equipment, defect-free masks, and dry processing. Applying the same methods to GaAs production will yield similar results, said Avery. To back that assertion, Avery pointed

to the results of one GaAs company that has matched the yields of bipolar ECL wafers with similar-sized dies.

Based on these preliminary showings, Avery sees the three current market segments shifting dramatically in the next 10 years.

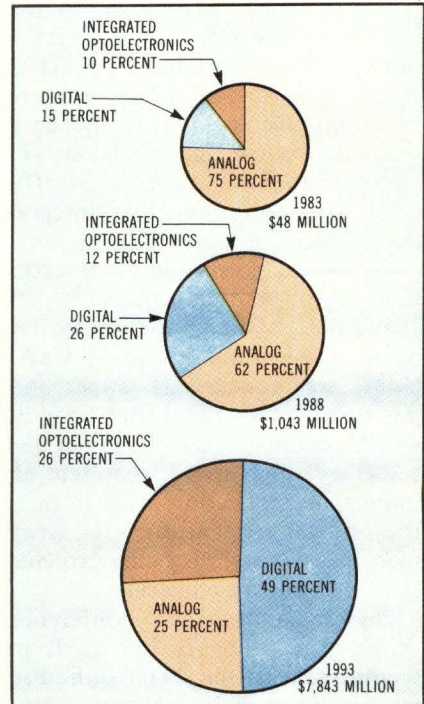

The world market shares of GaAs will change dramatically in the next 10 years. While the majority of circuits today are analog, by 1993 integrated optoelectronics will grow to a 26 percent share and digital circuits will dominate with an almost 50 percent share.

Analog applications, today a dominant market with a 75 percent share, will shrink to 25 percent by 1993, meanwhile digital applications, currently holding a 15 percent share, will expand to almost 50 percent, according to Avery. He makes these projections based on several assumptions. He expects resumed real GNP growth and GaAs market growth that will be demand-driven and supplier-limited. Avery claimed that the GaAs market will be independent from the silicon IC market. “Gallium arsenide ICs, I believe, are going to create their own very large

(continued on page 32)

GaAs chips shine

(continued from page 31)

niche," said Avery. Barry Gilbert of the Mayo Foundation (Rochester, Minn) agreed by stating, "The two technologies are complementary and should not be competing against one another directly."

In fact, Gilbert said, designers should be striving at both ends of the speed/integration spectrum to maximize the potential of both technologies. He advocates that silicon producers push integration to the hilt while GaAs designers exploit the natural speed advantage of GaAs rather than try to integrate more functions onchip. This would be a defeatist course, since silicon will continue to have the edge in efficient, single-chip function integration for some time.

Gilbert called on the GaAs community to take advantage of its strengths, which automatically opens applications as far as GaAs chips are concerned. Supercomputers like the Cray 1 and Cray 2, which use many MSI chips in parallel to achieve high speed, represent an important application area. In fact, the next generation of Cray machines, Cray 3, is being targeted for GaAs chips exclusively.

Gilbert and other conference speakers at Phoenix put faith in second-generation heterojunction technology to realize the supercomputer goal. Currently, gate speeds of first-generation GaAs devices suitable for volume production are in the 100- to 350-ps region. This is two to five times faster than the fastest commercial bipolar ECL devices.

Second-generation devices whose development is proceeding at a feverish pace both in the U.S. and Japan are exhibiting propagation delays of 10 to 50 ps. To take full advantage of these speeds, according to Gilbert, processor onchip architecture must have a radically different orientation. The number of gate delays on each chip must be maximized to reduce system performance loss caused by interchip connections.

Gilbert addressed a specific set of problems encountered at the Mayo Foundation. "We have been looking at signal processors where data rates are at least 100 Mbytes," said

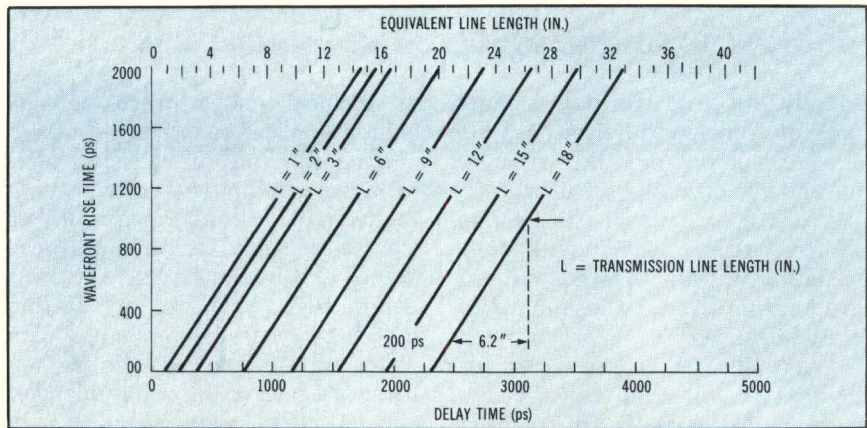

While deliberate degradation of offchip rise times can alleviate interconnection problems, overall system performance is also reduced. Computer simulations performed in the Mayo laboratories on the trade-offs between wire delays and rise time effects indicate that rise times as low as 100 to 200 ps result in substantial reduction in effective interconnect length.

Gilbert, "the clock rates in these processors are at least as fast as the data rates and, sometimes, 10 to 20 times faster. This is because a few microcycles of the engine are needed to capture and dispose each data byte as it enters and before accepting the next data byte." Thus, Gilbert's processor requires a clock rate that is sometimes 20 times higher than the data rate. "This is clearly a case where silicon VLSI is going to have trouble giving us the kind of performance we want, particularly toward the higher end," concluded Gilbert.

Serial solution

To solve this problem, according to Gilbert, there are two solutions. One is to have many coprocessors operating on the problem in parallel. This would be what the silicon VLSI community or the Department of Defense's Very High Speed Integrated Circuits program would opt for. The other approach would be to have a smaller number of processors connected in serial but operating at a much higher system clock rate—the GaAs solution.

For such a processor, logic and arithmetic algorithms would have to be written along the lines of recursive algorithmic forms. Systolic arrays would have to be implemented where the operands are not processed as full operands but are divided, and individual parts are screened through individual nodes.

Also, static RAMs would probably have to operate at 1- to 4-ns cycle time. This could be achieved with memories that use onchip pipeline registers for the address, as well as input and output data. Address counters and other control lines onchip would also help the process.

While a new onchip architecture would optimize the speed at which GaAs chips operate efficiently, one potential problem arises from transmitting high speed signals between chips while maintaining decent rise times and fall times. Skin effect, series inductance, and signal noise all come into play. Gilbert said that the correlation existing between a signal's rise time and the interconnect length between chips should be used wisely to maintain fast rise times and also sustain system performance.

Using computer simulations and based on a board dielectric constant of about 2.3, Gilbert showed that if the signal rise time is decreased from around 1000 to 200 ps, it is equivalent to saving 6.2 in. of interconnect length between any two chips on the board. This observation, according to Gilbert, can be interpreted in two different ways: "Either the chips could be spread apart by an average of 6.2 in. using this faster rise time and throughput and system performance would remain the same, or the system could be packed as densely as possible and

(continued on page 34)

THE ALL AMERICAN KEYBOARD



*Wireless Keyboards
too! Call me at
1-312-578-3524
Bob Terwall*

**...that
meets specs
worldwide.**

Cherry's new DIN-compatible pad capacitive keyboard:

- Low enough in profile to meet 1985 European ergonomic standards.
- Low enough in price to be your most cost-efficient spec.

Now, Cherry's proven pad capacitive technology is available in a low profile, linear feel, full travel key-module. A keymodule that's ideal for detached encoded keyboards. With a uniquely simple design that requires only five parts... that results in increased reliability. New ergonomic cylindrical button set with non-glare keycaps.

Another Cherry first is our new hex sense amplifier with six inputs that allow horizontal rows of keys to be attached with minimal printed circuit complexity... requires only six I/O lines from a microprocessor for operation. An inexpensive microprocessor that provides ASCII or other codes, N-key rollover, serial output and bi-directional serial interfaces.

Send today for complete technical and application data.



Just .704" (17.88mm) from PC board to keycap top of home row!



KEYBOARDS

CHERRY ELECTRICAL PRODUCTS CORP. 3614 Sunset Avenue, Waukegan, IL 60087 • 312/578-3500

GaAs chips shine (continued from page 32)

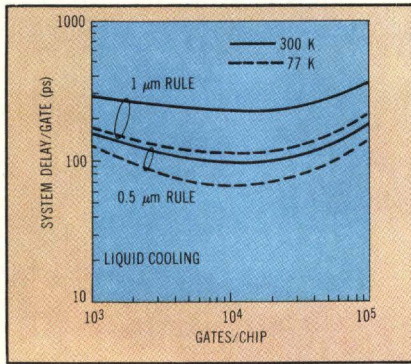

LSI complexity depends on system delay/gate. Fujitsu engineers were able to achieve an optimum system delay of 70 ps at a 10,000-gate integration level where the chip delay is 40 ps.

thereby gain in performance." Thus, the advantage of maintaining rise times should not preclude designers from solving problems associated with ultrafast switching.

Several computer manufacturers have large research programs to design supercomputers with GaAs circuits. Fujitsu, Ltd, (Tokyo, Japan) used the Phoenix conference to describe its efforts to design a general purpose computer with HEMT technology operating at a system clock cycle of 2 ns and exhibiting 120 million instructions per second performance. The company has achieved switching speeds of 12.8 ps for a ring oscillator using HEMT technology, while its 1-Kbit static RAM using first-generation metal semiconductor field effect transistor (MESFET) technology has

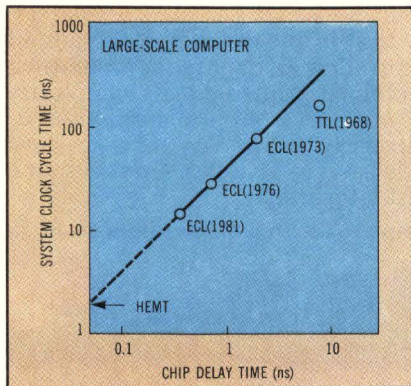

Fujitsu engineers were also able to improve system clock cycle time an order of magnitude over the best ECL technology by achieving a cycle time of 2 ns and by using HEMT second-generation GaAs chips.

an access time of 3.6 ns. If replaced by an HEMT-based RAM, access time would be less than 1 ns. Impressive to say the least. In general, the switching speed of HEMT is roughly three times as fast as GaAs MESFET technology, according to Fujitsu.

For evaluating desirable system performance of future high speed computers, Fujitsu engineers took into consideration the components that cause overall system delay. System delay results mainly from chip delay on the LSI chip and external wiring delay between chips. Usually, the chip delay time is calculated by summing the intrinsic gate delay, logic layout delay according to the fan-out capability, and the delay caused by the wiring on the chip. Fujitsu engineers calculated the delays based on experimental data for the HEMT devices with both a 1 μm gate length and a 0.5 μm gate length. The calculations were made for both 300K and 77K temperatures. Using 0.5 μm rule technology and liquid nitrogen cooling, an optimum system delay of 70 ps was achieved. This was done on a chip that had an integration level complexity of 10,000 gates, and the chip delay was 40 ps. This translates into a system clock time of 2 ns which is an order of magnitude improvement over the use of silicon-based ECL technology for such a computer.

Besides Fujitsu's efforts, serious work is being conducted at Toshiba, Mitsubishi, and Hitachi as well as a number of U.S. computer companies such as IBM, Honeywell, Hewlett-Packard, Harris, and instrument giant Tektronix. In fact, IBM can be expected to devote even more energy to this technology since the company decided to back off from extensive research into Josephson junction technology—until recently the leading contender to GaAs for high speed, low power design. Judging by all this interest, an objective observer might remark that, after many years, GaAs has come into its own to claim a place beside silicon for design of next-generation computers.

—Nic Mokhoff, Senior Editor

SYSTEM TECHNOLOGY
(continued on page 40)

What is "The Alps Advantage", and why is it important to you, our customers?

Essentially, The Alps Advantage encompasses a whole series of customer benefits, brought together to help give you a competitive edge in your marketplace.

Welcome To The Alps Advantage For design engineers, it means a vast array of electro-mechanical components and system products—particularly noteworthy for their innovative

technology, state-of-the-art performance, high degree of miniaturization, built-in quality and long-life reliability. It also means a never-ending flow of new product introductions and helpful application engineering assistance from our Technical Product Managers.

For purchasing and production people, The Alps Advantage takes on other meanings—competitive pricing, automated manufacturing facilities and on-time deliveries. Equally important, it means a special kind of philosophy based on a spirit of teamwork and cooperative customer relations.

The Alps Advantage is everything you need to improve your products and enhance your competitive position—and everything you'd expect from a world-class supplier. Since its founding in 1948, Alps Electric Co., Ltd. has experienced steady, stable growth—to a level of world-wide sales now up to \$1-billion per year!

We look forward to the opportunity of putting The Alps Advantage to work for you—to get started, please contact the Alps Sales Rep nearest you:

AL	Huntsville (Jack Harvey & Assocs.)	(205) 536-4414
AZ	Phoenix (Eltron)	(602) 266-2164
CA	San Diego (Harvey King, Inc.)	(619) 566-5252
CA	Santa Clara (Nova-Tronix, Inc.)	(408) 727-9530
CA	Woodland Hills (Relcom, Inc.)	(213) 340-9143
CO	Englewood (Nelligan Co.)	(303) 761-2121
CT	Yalesville (Technology Sales, Inc.)	(203) 269-8853
FL	Clearwater (Jack Harvey & Assocs.)	(813) 725-4900
FL	Ft. Lauderdale (Jack Harvey & Assocs.)	(305) 763-1945
GA	Norcross (Jack Harvey & Assocs.)	(404) 449-4643
IL	Arlington Heights (Micro Sales, Inc.)	(312) 956-1000
IN	Indianapolis (Jack Harvey & Assocs.)	(317) 872-1031
IN	Kokomo (Jack Harvey & Assocs.)	(317) 453-4260
KS	Kansas City (BC Electronic Sales, Inc.)	(913) 342-1211
KS	Wichita (BC Electronic Sales, Inc.)	(316) 942-9840
MD	Timonium (Allen Assocs.)	(301) 252-4133
MA	Waltham (Technology Sales, Inc.)	(617) 647-5700
MI	Oak Park (A. Blumenberg Assocs., Inc.)	(313) 968-3230
MN	Minneapolis (P.S.I.)	(612) 944-8545
MO	St. Louis (BC Electronic Sales, Inc.)	(314) 291-1101
NC	Greensboro (Wallace Electronic Sales)	(919) 996-2742
NJ	Boonton (PAF Assocs.)	(201) 335-0680
NY	Smithtown (PAF Assocs.)	(516) 360-0940
NY	Albany (Reagan/Compar)	(518) 489-4777
NY	Endwell (Reagan/Compar)	(607) 723-8743
NY	Fairport (Reagan/Compar)	(716) 271-2230
NY	New Hartford (Reagan/Compar)	(315) 732-3775
OH	Rocky River (Norman Case Assocs.)	(216) 333-0400
OK	Tulsa (Norcom, Inc.)	(918) 832-7747
OR	Aloha (Venture Electronics)	(503) 642-9090
PA	Willow Grove (Harry Nash Assocs.)	(215) 657-2213
TN	Johnson City (Jack Harvey & Assocs.)	(615) 928-7588
TX	Dallas (Norcom, Inc.)	(214) 386-4888
TX	Austin (Norcom, Inc.)	(512) 451-2757
TX	Houston (Norcom, Inc.)	(713) 933-6021
VA	Lynchburg (Burgin-Kreh Assocs., Inc.)	(804) 239-2626
WA	Bellevue (Venture Electronics)	(206) 454-4594
WI	Milwaukee (Micro Sales, Inc.)	(414) 782-1171
CANADA:	St. Laurent (Vital Electronics)	(514) 331-7393
CANADA:	Mississauga (Vital Electronics)	(416) 676-9720
CANADA:	Kanata (Vital Electronics)	(613) 592-0090

The Alps Advantage in 5¼" floppy disk drives:

Miniaturized for less space, more storage capacity. Since 1948, miniaturization has always been an important part of The Alps Advantage. In our 5¼" floppy disk drives, the advantage is immediately apparent: you can double (or quadruple) your storage capacity in the same space! And it's all done without any sacrifice of design or performance features:

Brushless DC motor. Models available with standard brush motor, or new brushless DC motor with 10,000 hours life rating and higher operating reliability without brush noise.

Built-in electronics control board. Models also available as mechanism only, without analog control board.

High speed access time. Choice of 5 or 12 millisecc. track-to-track access time, achieved by the use of a unique steel belt head carriage design.

Up to 500 Kbytes storage capacity. Single or double side, single or double density models. 48 TPI track density. Head load time 35 millisecc. FM (single density) or MFM (double density) recording method.

Automatic disk eject. Media removal is fast, smooth and easy.

Simple design, high reliability. High precision ultra-thin stepper motor is combined with a unique hub collet configuration in a simple, reliable design for improved accuracy in head positioning and media clamp centering.

Improved disk life. A ceramic based magnetic head protects the media from excess wear and provides increased accuracy of data readout.

World-wide acceptance. Many thousands of Series 2000 drives have been delivered to OEM manufacturers throughout the world. You can easily learn what they already know about The Alps Advantage—just write or call today.



ALPS ELECTRIC (USA), INC.

100 N. Centre Ave., Rockville Centre, NY 11570
Phone 516-766-3636 • Telex (WU)14-4508

**Low profile Series 2000.
Only 1.61" thick—half the size
of conventional units!**



If you don't find the logic you probably don't need

Meet the logic analyzer family that spans a wide spectrum in design. It's a family you can rely on in hardware design, software test and debug and even system performance analysis. One that's equally at home testing and troubleshooting low-cost single processor designs or sophisticated multiprocessor systems.

You can choose from a wide selection of different logic analyzer configurations with HP. And when you do, you'll have an analysis solution that can help accelerate your design cycles...and speed your products to market.

The 1630A and 1630D...for confidence in tackling the day-to-day logic problems.

Choose one of these logic analyzers and you'll have the combined power of timing, state, and software performance analysis in one convenient, low-cost instrument. At just \$8,600*, the 1630A gives you 35 channels of state/performance analysis (to 25 MHz), or 8 channels of timing (to 100 MHz). In the interactive measurement mode, it delivers 27 channels of state and 8 timing.

For \$10,630*, the 1630D offers 43 channels of state/performance analysis or 16 timing. In the interactive mode, you have a choice of 35 state and 8 timing or 27 state and 16 timing.

As your primary tool in hardware test and debug, the 1630 provides new triggering power to help you isolate the source of timing errors. This includes pattern triggering ANDed with a transition or glitch, edge or glitch triggering, and time qualification of pattern triggering. This is the capability that helps you quickly solve difficult hardware problems such as timing errors, transient effects and handshake malfunctions.

Use the 1630 in software development and integration phases and you have sequencing, triggering, store qualification, and sequence restart power to isolate targeted areas of code and view just the measurement information you desire.

To optimize your system performance, the 1630 gives you a nonintrusive view of system software in action. One that lets you analyze system activity at the level of procedures and tasks instead of the instruction level. Histogram displays make it easy to spot software bottlenecks and inefficiencies. The result can be improved system performance, and a more competitive product...with minimal additional design effort.

The 1630 also gives you interactive measurement capability for greatly enhanced analysis power. The ability to cross arm and trigger between state and timing analyzers helps you get to the problem source quickly when the difficulty could be either a hardware or software malfunction.

Throughout the development cycle, you'll find the 1630 easy to use. That's because menus simplify operation. Label assignments let you view results in your system's terminology. And inverse assembly, via low-cost peripherals, displays listings in familiar target microprocessor mnemonics.

The 64110A...a configurable analyzer that can handle those complex problems found in multiprocessor environments.

This logic analyzer is, in reality, a number of different analyzers, depending on how you configure it. For example, it can be a standalone timing analyzer with 8 or 16 channels.

It can also be a standalone state analyzer with up to 120 channels. You can combine timing and state with performance overview. Or, combine multiple state or timing analyzers in the same station.

Price for the 64110A,



analyzer you need here... a logic analyzer.

including a 60 channel state analyzer subsystem with performance overview is \$21,870*.

Put the 64110A to work in the hardware test and debug phase and you can allocate high speed timing resources. For example, you might choose sampling speeds to 400 MHz. The resulting 2.5 ns resolution lets you make high-resolution measurements to resolve timing margin problems.

In addition, the timing analyzer provides new triggering capability. The dual threshold mode lets you trigger on marginal signal levels, which helps you spot excessive fan-out, bus loading problems, and slow transition times. Other trigger modes include time qualification of pattern triggering, sequential triggering, pattern triggering ANDed with a transition or glitch, glitch triggering, plus other modes that simplify the analysis of handshake problems.

In software test and debug, the 64110A gives you unequalled tracing, triggering, and store qualification power. With its master enable function, 16-level sequencer plus 8 user-definable terms for trigger, store qualification and count functions, you'll have little trouble locating the specific portion of code you want and displaying only the information

of interest...even in the most complex multiprocessor software.

For system performance analysis, the 64110A gives you a nonintrusive view of software in action in the form of histogram and graph displays. The histogram modes provide a fast way to locate system bottlenecks and identify inefficient portions of software. These display modes help you identify a processor stuck in a loop, see where software went into the weeds, or spot activity occurring in a forbidden area. A graph mode shows software performance data in chronological order.

Interactive measurements between all analyzer subsystems multiplies the power of the 64110A far beyond the capability of other logic analyzers. Cross arming and triggering between any of the analyzer subsystems helps identify the source of difficult hardware/software interaction problems, and resolves hardware/software fingerprinting issues.

In any phase, the 64110A is a pleasure to use. Directed syntax softkeys guide you through setups and measurements with a minimum of

keyboard entries. Symbolic tracing means you interface with the analyzer using terminology you're familiar with. And preprocessors with inverse assemblers let you view measurement results in familiar processor mnemonics. All of which lets you concentrate on the problem you're trying to solve...not the analyzer.

Choose both and you'll have your analysis needs covered.

When you combine both of these analyzers in your lab, you have a cost-effective solution to the day-to-day test and debug tasks, plus the power to deal efficiently with those complex troubleshooting jobs.

So before you buy any logic analyzer, be sure you explore the individual power of HP's standalone analyzers...and the synergistic effect of a combination of instruments.

For complete details, call your local HP sales office listed in the telephone directory white pages. Ask for an HP field engineer in the electronic instruments department.

*U.S.A. list price only.



HP-IB: Not just IEEE-488, but the hardware, documentation and support that delivers the shortest path to a measurement system.



HEWLETT
PACKARD

HOW TO CHOOSE A DISK DRIVE, PART II:

Your new computer system may be in for a cool reception.



Here's a cold, hard fact that should influence your selection of a disk drive for multi-user computer systems or local area networks: In today's energy-conscious offices, temperatures can vary enough during the

day to affect the performance of a disk drive. We made the operating range of ATASI drives up to 25% greater than most competitive drives because poor performance under thermal stress can result

in system downtime and even lost data. Here's how it happens.

In most drives, the bottom of the bowl serves as the base-plate where the carriage and spindle assemblies are

STRESS

mounted. There is no thermal isolation. Heat from the motor, PC boards or a power supply can result in differential expansion of the baseplate, so that it temporarily warps. This can change the alignment of the carriage and spindle, which in turn affects the drive's ability to find data reliably.

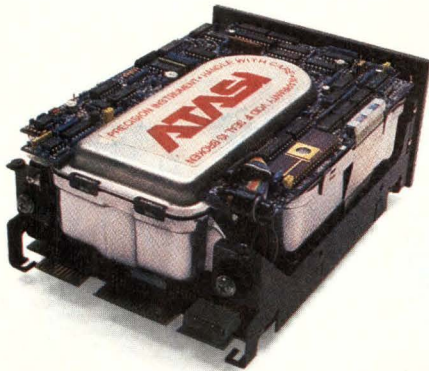

ATASI's 46 Mbyte, 5 1/4-inch Winchester disk drives are available in production quantities immediately.

Alignment problems

In high-performance, closed-loop drives, servo information carried on the bottom surface of the disk stack is used to position the data heads on all other surfaces. Assume that data is recorded when the drive is "cold." If the carriage and spindle go out of alignment when the drive gets "hot," the servo system cannot properly position the read/write heads to recover the data. This may mean that data written in the morning won't be accessible the same afternoon!

Thermal isolation

To prevent this from happening with ATASI's 5 1/4-inch Winchester disk drives, the ATASI design incorporates a baseplate which is separate and thermally isolated from

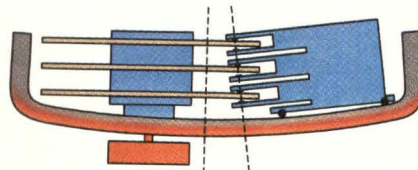

Heat can temporarily warp a drive's baseplate, causing alignment problems between carriage and spindle.

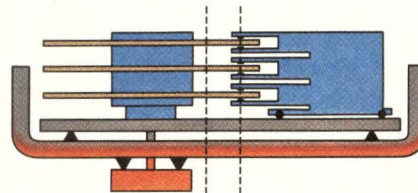

Thermal isolation in ATASI's proprietary design eliminates the problem.

the lower half of the bowl. The baseplate is therefore protected from external sources of localized heat. Even if the drive heats up, it does so uniformly, with no resultant deformation of the baseplate, and no alignment problems.

Extra margins

Thermally isolating key mechanical components is one way we improve the performance of ATASI drives, but not the only one. Everywhere in the design there are margins of safety other drives don't offer. For example, our proprietary spindle motor design provides substantially

greater dissipation of heat away from the disk module than competitive drives.

The ATASI White Paper

At ATASI, we are proud of the quality we build into every drive we make, and we encourage clients to test our products rigorously. To help, we have prepared a White Paper on thermal testing which discusses test methods and interpretation of test data in detail.

If you are a systems integrator, contact ATASI Corporation now to receive your ATASI White Paper. Corporate headquarters: 2075 Zanker Road, San Jose, CA 95131, (408) 995-0335; Eastern region: (617) 890-3890; Southwest region: (714) 432-0757.

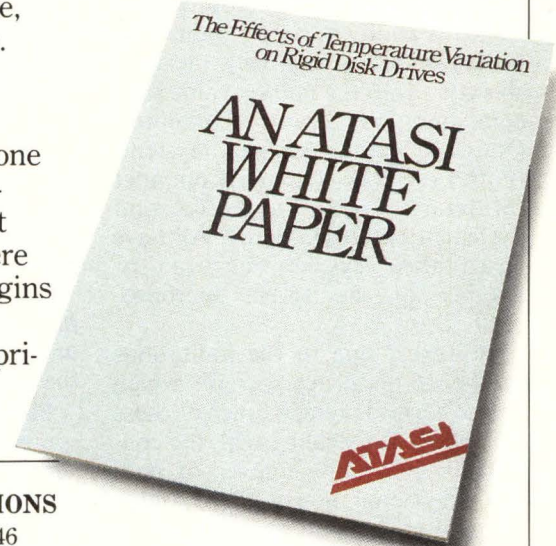

PERFORMANCE SPECIFICATIONS

MODEL NO.	3033	3046
CAPACITY	33 MB	46 MB
ACCESS TIME (AVG.)	30 ms	30 ms
DATA RATE	5 Mbits	5 Mbits
INTERFACE	ST 506	ST 506

Available in high volume today.

MODEL NO.	3065	3075
CAPACITY	65 MB	75 MB
ACCESS TIME (AVG.)	24 ms	24 ms
DATA RATE	5 Mbits	5 Mbits
INTERFACE	ST 506	ST 506

Available second quarter, 1984.

© 1983 ATASI Corporation

Fault tolerant systems deal with increased loads

Moving away from batch processing central computer systems, the transaction processing market has grown by leaps and bounds. In the move, these systems have become distributed. Remote sites continually transmit data to one another or to the central site. To ensure continued operation of both the systems and the links, fault tolerant systems came into being.

Tandem Computers (Cupertino, Calif), was not only the first to recognize these needs—and supply a method of preventing a single failure from stopping the system—but the fastest in responding to increased demands. The company's entry into this field, the NonStop system, was based on redundant 16-bit processors. As the demands for such reliable systems grew, additional vendors moved in to fill their need for increased distributed systems and the growing work load.

With the 16-bit microprocessor came the ability to supply redundant processors at a relatively inexpensive cost. Into the market came such companies as Stratus Computers (Natick, Mass), Auragen Systems (Fort Lee, NJ), Synapse Computer (Milpitas, Calif), and Tolerant Systems (San Jose, Calif). All have based their systems on one or another of the 16-bit microprocessors.

However, due to the limitations of the 16-bit processors on which they are based, systems such as these have difficulty dealing with the continually expanding masses of data and additional users, all of which demand reasonable response times. Tandem's recent upgrade, the NonStop TXP, builds on 32-bit mini-computer technology to answer these needs. Tandem's architecture depends on total redundancy. Multiple processors, dual-bus communications, dual-ported controllers, and multiple power supplies are inherent.

All processors independently process different applications, instructions, and I/O operations in parallel. However, if a module or data path fails, its counterpart automatically takes over to complete work in prog-

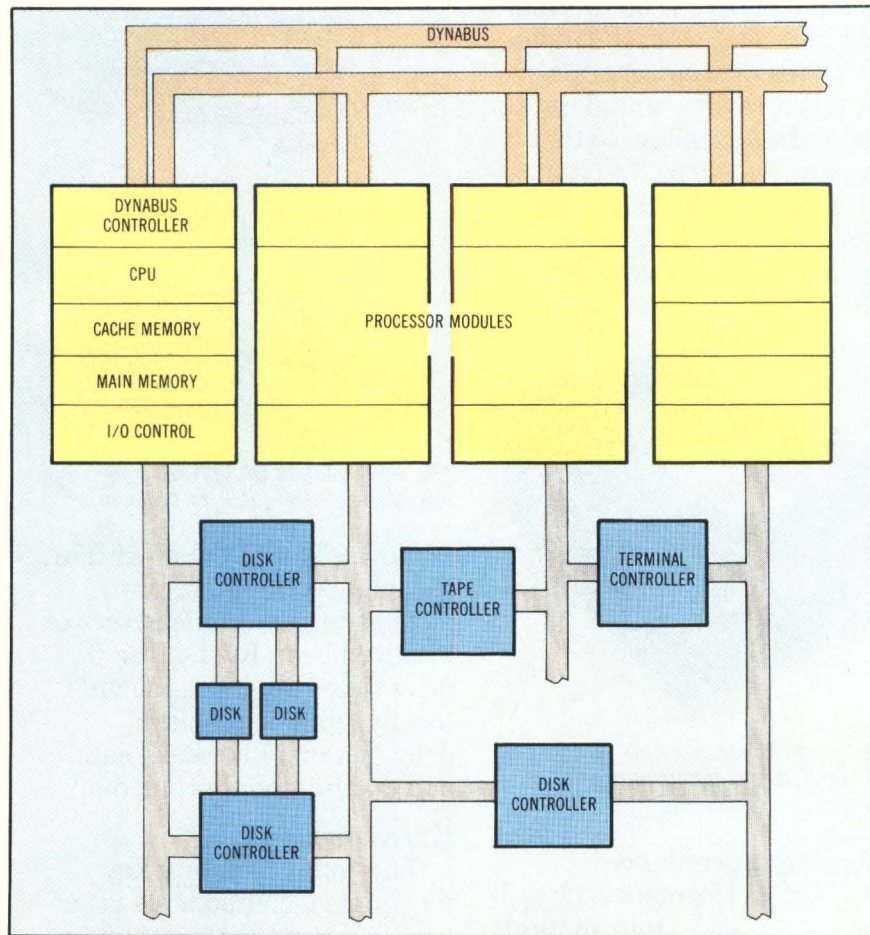

Tandem's NonStop TXP eliminates single points of failure through total duality. If any module or data path fails, its corresponding device or alternative data path automatically takes over to complete the function.

ress. The faulty part can be replaced or repaired without shutting down the system.

Each processor module is a 32-bit computer with a 32-bit native addressing mode and a 64-bit path to main memory. Each processor has its own 64-Kbyte hardware cache memory, and each can address 1 Gbyte of virtual memory.

Using three levels of instruction overlap achieves computational performance. This allows the processor to fetch one instruction and preprocess a second while executing a third. The CPU cycle time is 83 ns. Based on a 98-percent cache hit rate, effective memory access time is 116 ns.

From 2 to 16 processors are accommodated in a single system. From 2 to 14 systems are linked through a 4-Mbyte/s fault tolerant fiber optic interface to form a

local network. Geographic dispersion is handled through networking software.

The system's 64/32/dual 16-bit design allows application programs written for any NonStop system to run on the TXP. Transfer requires no changes in code and results in two to three times greater throughput.

Gaining data integrity

Each CPU supports one to four 2-Mbyte memory boards. Control signals between the CPU and memory are continually checked. Single-bit error correction (SEC) and double-bit error detection (DED) are performed on data; single-bit error detection (SED) occurs on addresses.

Among the system's data integrity safeguards are validation checks that are performed by operating system

(continued on page 43)

Fill in your IBM micro/mainframe communications picture.

AST Research, the leader in IBM PC enhancement products, brightens your micro/mainframe communications picture with a full palette of economical, integrated hardware/software masterpieces. With AST Products, you can emulate IBM terminals or create PC-based Local Area Networks.

AST improves your office operating cost picture.

AST communications products give your IBM PC the flexibility to act as a terminal for your host system or as a stand-alone computer for smaller tasks. Your PC won't bog down the mainframe with unnecessary small jobs and local computing on the PC eliminates phone line charges too. Get the power of a mainframe when you need it and personal computer convenience right at your fingertips.

Applications solutions that are strokes of genius.

AST keeps pace with your ever-changing applications requirements with reliable, high quality, cost effective communications products. AST products provide support for Bisync and SNA/SDLC communications protocols as well as networking multiple PCs for sharing resources.

CIRCLE 24

Choose AST products — by the numbers.

These AST communications packages are currently available:

1. **AST-SNA™** emulates a 3274/3276 controller and 3278 or 3279 display terminal using SDLC protocol.
2. **AST-BSC™** emulates 2770 batch RJE and remote 3270 display terminals using 3270 Bisync protocol.
3. **AST-PCOX™** allows your PC to connect to an IBM 3274/3276 cluster controller via coax cable and emulates a 3278 or 3279 display terminal.
4. **AST-3780™** emulates 2770, 2780, 3741, and 3780 RJE workstations using Bisync protocol.
5. **AST-5251™** emulates a 5251 Model 12 remote workstation connected to an IBM System 34, 36 or 38.
6. **PCnet™** is the first Local Area Network designed specifically for the IBM PC or XT and the PC-DOS 1.1 or 2.0 operating system.
7. **CC-232™** is a user-programmable dual-port card capable of communicating in Async, Bisync, SDLC, or HDLC protocols.

Discover how well AST can fill in your micro/mainframe communications picture. For descriptive data sheets, write or call: AST Research Inc., 2121 Alton Ave., Irvine, CA 92714. (714) 863-1333. TWX: 295370ASTRUR



AST
RESEARCH INC.

**Number One Add-Ons
For IBM PC.**

IBM is a registered trademark of International Business Machines Corporation. PCnet is a registered trademark of Orchid Technology, Inc. AST-3780 is a product developed by AST Research, Inc., and Wilnot Systems, Inc. AST-5251 is a product developed by AST Research, Inc., and Software Systems, Inc., of Jefferson City, MO. PCOX is a product developed by CXI Inc.



SSI-INNOVATORS IN DISK DRIVE INTEGRATION

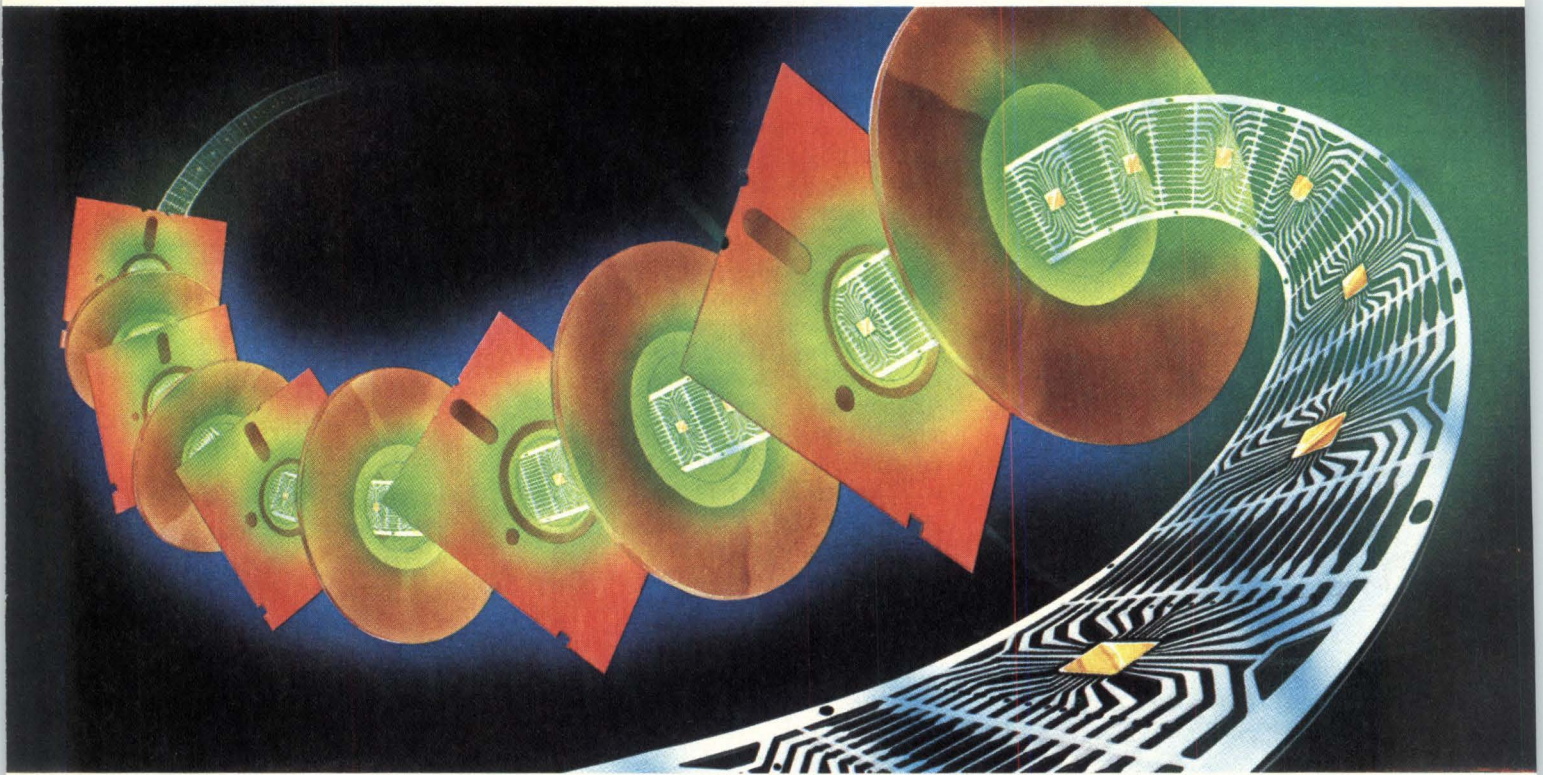

We've delivered more read/write IC's than everyone else combined, but we're not satisfied.

Everyone knows that Silicon Systems dominates the market with read/write IC's for 14", 8", 5-1/4", and smaller Winchester disk drives. What they may not know is that we're not satisfied to stop there. Although our present line of rotating memory circuits includes much more than read/write IC's, we won't be satisfied until we completely integrate Winchester disk drive electronics. And we are continuing to expand the industry's most complete line of "Applications Specific" IC's for Winchesters, Floppies, and Tape Drives.

We're also the leading innovators in custom IC's for use with mass storage systems.

In addition to our broad line of standard circuits, we have developed a host of innovative custom IC's for use with a variety of mass storage systems. We have produced custom IC's for read/write electronics, spindle motor control, analog data processing, digital bus interface, and servo control functions.

For rigid and floppy disk drives, or tape back-up systems—if the circuit you want isn't in our standard line, we have the capability to produce it for you. We have

the analog and digital design capability, the Bipolar and CMOS process technology, and the rotating memory IC experience to make the exact custom chip your system needs.

For more information on our standard products and custom capabilities, send for our "Rotating Memory Integrated Circuits" brochure.



Silicon Systems incorporated,
14351 Myford Rd., Tustin, CA 92680
(714) 731-7110, Ext. 575.

silicon systems
INNOVATORS IN INTEGRATION

NEW HI-PERFORMANCE FLOPPY DISK CIRCUIT

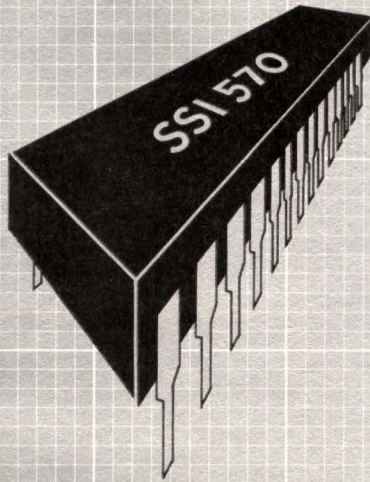

Silicon Systems' latest innovation in disk drive integration is the SSI 570. This creative design by Silicon Systems engineers integrates both the read and write data processing functions on one, 2-channel, monolithic IC. The circuit is designed for use with 8", 5-1/4", and 3-1/4" double-sided floppy disk drives.

The write data circuitry includes the erase head drive with programmable delay and hold times, and the read data circuitry includes low noise amplifiers for each channel. This TTL compatible circuit operates on +5 and +12 volts and is provided in a 28-pin plastic DIP package.

For more information on this new advanced product from the leader in disk drive integration, contact: **Silicon Systems**, 14351 Myford Road, Tustin, CA 92680, (714) 731-7110 Ext. 575.

silicon systems
INNOVATORS IN INTEGRATION

CIRCLE 155

Fault tolerant systems (continued from page 40)

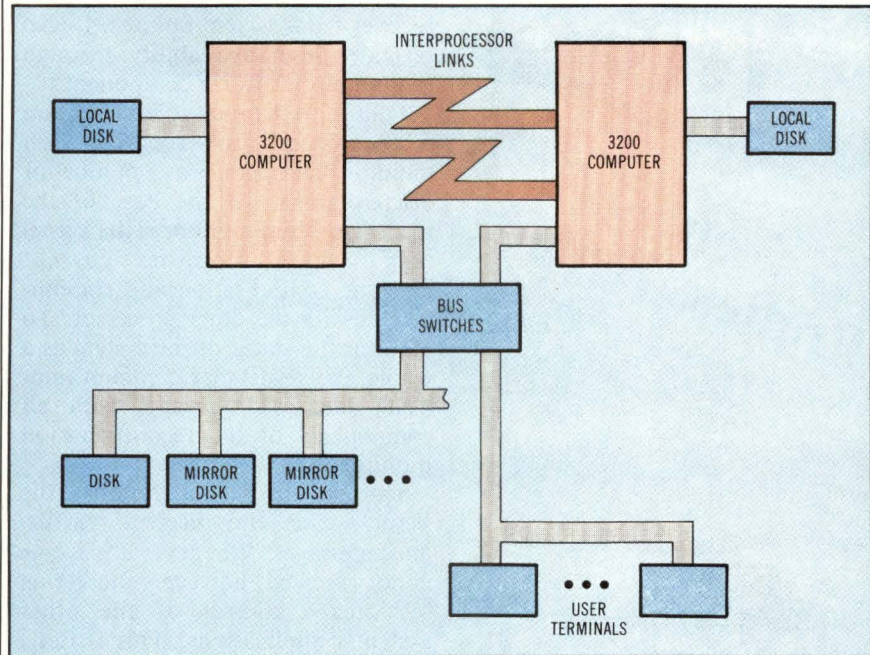

Perkin-Elmer's Resilient system combines redundant hardware components with reconfiguration monitor software. In addition, it allows independent operation of processors while providing either with the capability to take total control if necessary.

software on data transfers. System-level safeguards include parity checking on data paths, checksums on bus transfers, and SEC/DED on data in memory. End-to-end checking ensures that messages are transmitted correctly.

To this end, the CPU includes parity prediction algorithms for a program counter, an interval timer counter, and a microcode address incremter. Parity checking occurs on critical data paths. Buried in microcode is a function that freezes the CPU when a hardware fault is detected.

Success breeds competition

Traditional minicomputer vendors have also recognized the potential to expand into this market. Mid-1983 found Digital Equipment Corp (Maynard, Mass) entering the arena with its VAXcluster. Using multiple VAX processors and intelligent storage subsystems connected through a star coupler, the concept enables all components to function as a single system. Serving as the basis for the system, the star coupler connects eight nodes through computer interconnect bus cables. To provide redundant

70-Mbps data paths, each bus consists of two transmit and two receive cables.

Processors connect to the bus through intelligent controllers. The interface uses whatever path is available. This enables high throughput to be achieved when both are available. It also allows one path to handle all traffic if one becomes unavailable. All traffic is automatically shifted to the available path when one is unavailable.

Integral to cluster operation, VAX VMS operating system software versions 3.3 and 3.4 have provisions for dual-ported disks between storage controllers. Other releases take advantage of the hardware's data protection and fault tolerance potential, thus enabling the system to survive and reconfigure around failed components.

Attempting to outgun Tandem, Perkin-Elmer's Data System's group (Tinton Falls, NJ) has put its 3200 series machines together with database software to form what it calls the Resilient system. The system combines existing 3200 series superminicomputers with software designed to automatically sense and

(continued on page 44)

Full Story:

Woven Endless Belts

Woven Endless Belts offer an economical space saving method of driving, transport and feed for applications such as copiers, disk drives, money and banking equipment and in-line weighing devices. These belts are very strong, flexible, and capable of operating at high speeds. Special covers and material offer engineers a wide range of design options.

CIRCLE 25

Timing Belts and Pulleys 40 DP, MXL and XL

Belting Industries has one of the nation's most complete lines of mini and small pitch timing belts and pulleys at the most competitive prices available. Pulleys are constructed of lexan and aluminum.

CIRCLE 26

For more information, call Belting Industries Hotline:

1-800-526-6824

(in New Jersey, call 201-272-8591) or please write us at:

Belting Industries Co., Inc.
20 Boright Avenue
P.O. Box 10
Kenilworth, NJ 07033

Other locations: Norcross, GA
Boulder, CO Sodus, NY



SYSTEM TECHNOLOGY/ COMPUTERS

Fault tolerant systems

(continued from page 43)

recover from system failures. It also provides high availability through redundant hardware components.

Central to the fault tolerant nature of the system is the reconfiguration monitor that operates as a number of discrete tasks. At the base of the reconfiguration monitor is the kernel task, which monitors current machine configuration and communicates with the other processor. To monitor the status of the system as a whole, the kernel task communicates using intertask messages with all components of the reconfiguration monitor.

During normal operations, the kernel sends and receives reassurance messages. Whenever a message is not received, however, the kernel task takes control of the other system's applications. This is done by running command substitution system (CSS) files to acquire necessary peripherals and then running other

CSS files to load and start the application.

The monitor runs in both computers. On detection of a failure in the other system, the monitor activates bus switches to take over peripherals from the failed system and performs actions to load and restart the failed application or system. The monitor can act on operator commands to reconfigure the system for normal engineering maintenance.

These systems have eliminated the necessity for maintaining a "hot standby" to protect transactions. By allowing each processor to handle tasks independently, throughput remains high until a problem develops. Meanwhile, these systems offer assurance that all transactions can be completed and that the integrity of the data base will be maintained should a component within the system fail.

—Peg Killmon, Senior Editor

SOFTWARE

Multipass compilers produce tight code

Compilers generally go through two stages to produce tight object code. In the first stage, a front end processes a text file that contains source code. Its output is in an intermediate language (IL) not specific to any given CPU architecture. Often as part of the compiling process, a global optimizer processes the IL. This process examines the whole program to identify parts of the code that can be combined or eliminated.

The optimized IL is then passed to a back end that generates object code for a specific CPU. The object code is then scanned by a peephole optimizer. This optimizer, in turn, scans small chunks of code (typically 6 to 12 instructions) to speed up loops, and make the best use of the CPU registers.

Optimizers and optimizing compilers have been available in the academic and scientific world for a number of years. They were mainly written in-house and aimed at specific processors, such as the CDC Cyber Series and the Illiac parallel processor. However, these tools were

not easily available to outside designers, nor were they adaptable for use with other CPUs.

Optimizers add speed to applications

Block-structured languages (principally C, Pascal, and Ada) have by and large taken over from Fortran and Assembler in scientific and engineering applications. At the same time, compiler writing technology has become much more sophisticated, and users are demanding and getting more efficient tools from language vendors. Memory space is no longer a critical issue in microprocessor development, but speed is, and an optimizer can speed up an application program significantly.

In the mainframe and supermini world, several semiconductor houses, including Intel (Santa Clara, Calif) are using Mainsail, a block-structured language and operating system from Xidak, Inc (Menlo Park, Calif), as the underlying language for their computer aided

(continued on page 46)

Gould... Innovation and Quality in Computers

We just gave the computer industry something to reach for. A new standard... performance/footprint.

Introducing the Gould CONCEPT 32/67. Performance in a size as accommodating as its price.

From the 32-bit performance leader comes yet another minicomputer product line other suppliers can only hope to duplicate. The 2-MIPS-class, cost and space-saving CONCEPT 32/67.

We scrimped on size, but that's all. The 32/67 gives you top computational power in 1/5 to 1/3 the floor space of the

competition. And it's packed with features. Performance up to 2.6 MIPS. Largest cache in a mini ... 32K byte two-way set associative with separate 16K banks for data and instructions. And, 16M byte task addressing in a base register mode. All at a price that matches its size.

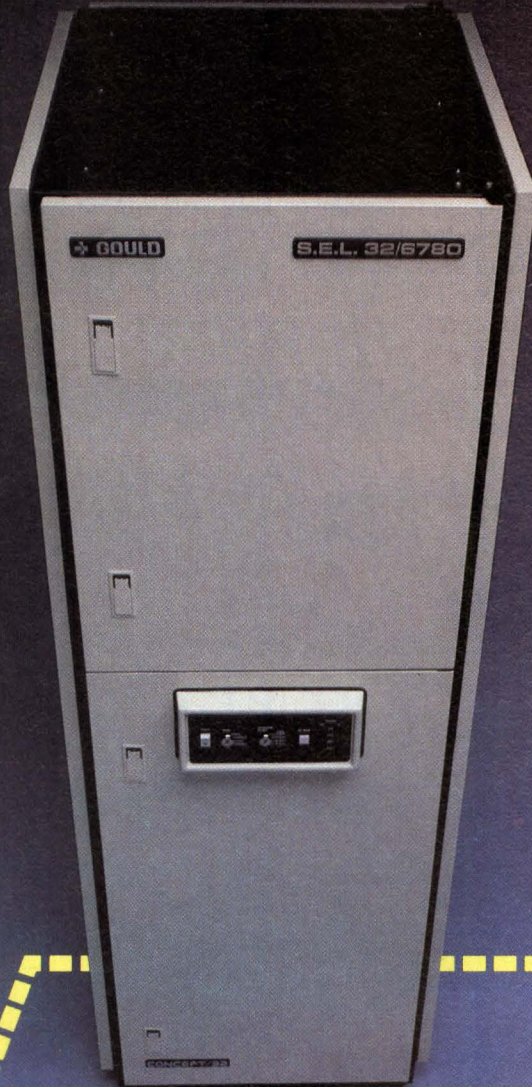

MIPS/SQ. FT.*

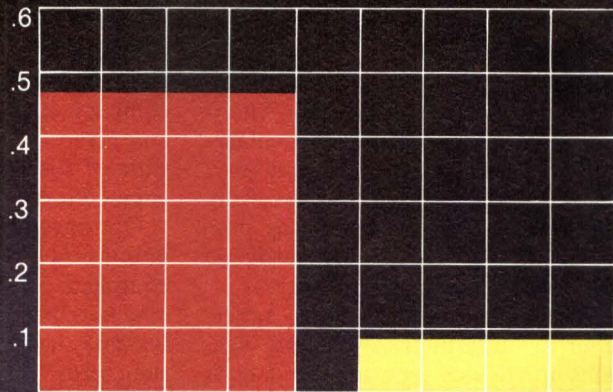

CONCEPT 32/6780 VAX 11/782

MIPS/\$10,000* (Equivalent System Price)

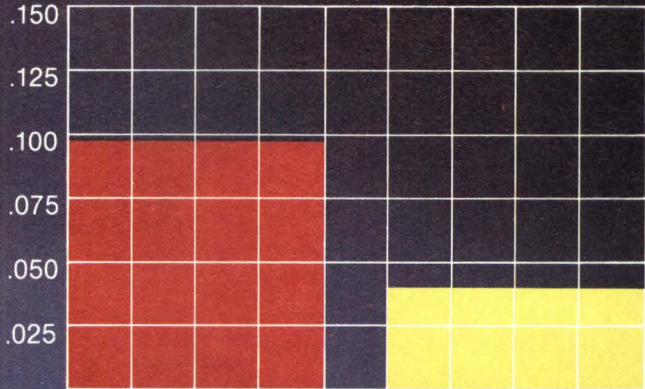

CONCEPT 32/6780 VAX 11/782

* All chart data from published competitive information.

For more information about the new standard of minis, call or write: **Gould Inc., Computer Systems Division**
6901 West Sunrise Boulevard
Fort Lauderdale, Florida 33313. 1-800-327-9716.

VAX 11/782



GOULD
Electronics

Multipass compilers

(continued from page 44)

design/computer aided manufacturing applications. The language runs on the IBM 370 architecture (machines from IBM, Amdahl, and others), as well as on superminis from Digital Equipment Corp (Maynard, Mass), Apollo Computer (Chelmsford, Mass), Sun Microsystems, Inc (Mountain View, Calif), and Ridge Computers (Santa Clara, Calif).

An optimized IL file produced on any one of these machines can be transported to any of the others, converted to object code, and run without change. Since it deals with only one source language, the Main-sail IL optimizer is not particularly general. According to the company, however, the IL itself was carefully designed to be as versatile as possible, so that code could easily go from one machine to another.

On minicomputers and super-micros, Intermetrics (Cambridge, Mass) provides separate front ends to compile its Pascal and C lan-

guages to an optimized IL. The front ends also provide back ends to generate object code for the Motorola 68000 or the Intel 8086 family CPUs.

In describing a source-level debugging system that Intermetrics developed in conjunction with Gould Inc, SEL Computer Systems Div (Fort Lauderdale, Fla) to run on a microprocessor development system (see this month's staff report by Tom Williams, p 149), Ron Kole, president of the Software Products Div at Intermetrics, points out that it is possible to do too much optimization. Multipass optimizers that compact and speed up code by any given factor are well within the state of the art of modern software engineering.

Optimizers slow down the compilation process. They also change the compiled code, so that debugging, whether by hand or automatically, becomes harder. Unless special data structures for ports and toggles are built into the compiler, memory ref-

erences that signal the hardware to do something may be eliminated by the optimizer when it finds that the data is not used anywhere in the program.

For this reason, a balance must be struck between doing too much and too little. Eliminating dead code and common subexpressions (ie, doing the same address calculation several times at different places in the program), doing only as much calculation as absolutely necessary to evaluate Boolean expressions, and doing constant arithmetic at compile time all speed up a program. Doing too much can distort the program structure to the point where it no longer does the job for which it was designed. Both the compiler writer and the end user have to use good judgment in deciding how much or how little optimization to do on any given program.

TeleSoft (San Diego, Calif) also uses an IL in the Ada compiler it offers for various microprocessor

Fujitsu: World-Class Components

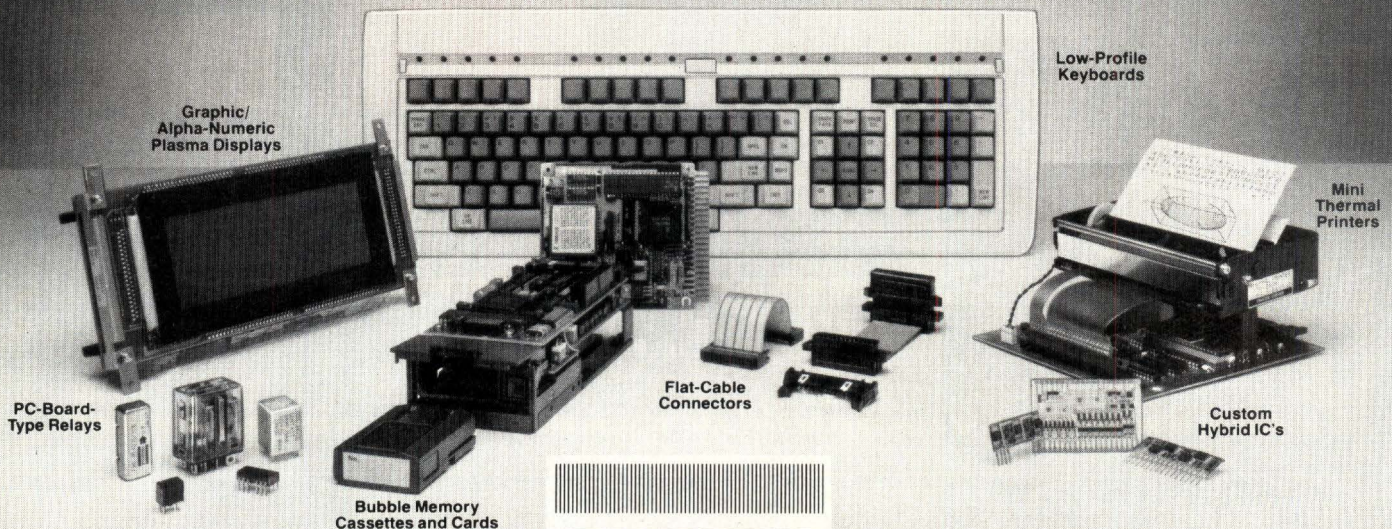

FUJITSU



World-Class Components
Part of Tomorrow's
Technology

Component Division Fujitsu America, Inc.
918 Sherwood Drive, Lake Bluff, IL 60044
(312) 295-2610 Telex: 206196 TWX: 910-651-2259

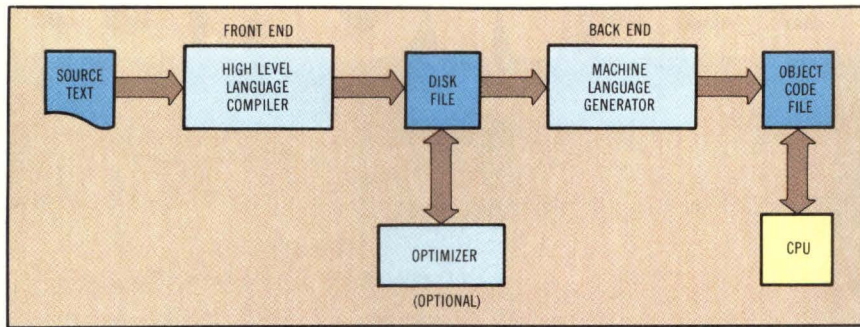

Intermediate language (IL) representations of high level language programs make them more general and more transportable. Optimizers for the IL and object code, working with the back end, tailor the program for a variety of CPUs.

architectures. According to Tom Dent, the company's president, this was seen as the only practical and cost-effective way to support the large number of machines that would be running Ada.

It is also seen as a way to maintain flexibility for future growth in directions other than Ada. While declining to talk about any specific future products, Dent stated that TeleSoft is not exclusively committed to Ada,

and would consider supporting other languages and applications in the future. New architectures (32-bits and up) are also being developed, so separating high level language parsing from the generation of machine specific object code is a necessity.

Is a standard IL impossible?

All intermediate languages are individual. There is no "standard

intermediate language," just as there is no "standard computer architecture." One school of thought in computer science maintains that a standard is impossible—that in order to generate efficient code, there must be a correspondence between the IL and the architecture of the machine on which it will run.

Others maintain that if enough information on both the language and the ultimate machine architecture is provided to the compiler and the optimizer, that satisfactory (and even excellent) code can be generated for any program in any language on any machine. Neither point of view can be shown to be absolutely correct, but widespread use of both IL and optimizers can be expected to increase dramatically in the future.

—Sam Bassett, Field Editor

SYSTEM TECHNOLOGY
(continued on page 49)

World-Class Components Update: FLAT CABLE CONNECTORS

Only Fujitsu Connectors Give You A World-Class Connection

All flat cable connectors are not created equal. There is a difference. And the difference is Fujitsu. Fujitsu knows that an expensive piece of equipment is only as good as the connectors tying it together. That's why we have always been first in making technological advances to give you the most reliable connectors in the world. Such as our exclusive U-Contact that has *four* cutting surfaces to pierce the insulation *twice* in the same place. Dual-Beam Contact design that assures positive contact with every connection. Tin-plated terminals as standard. Our own automated plating process that assures

consistency for very close tolerances. The Fujitsu difference gives you the highest reliability with a uniquely comprehensive product line that covers almost every possible flat cable connection: Mini and Block Headers; DIP and Card Edge;

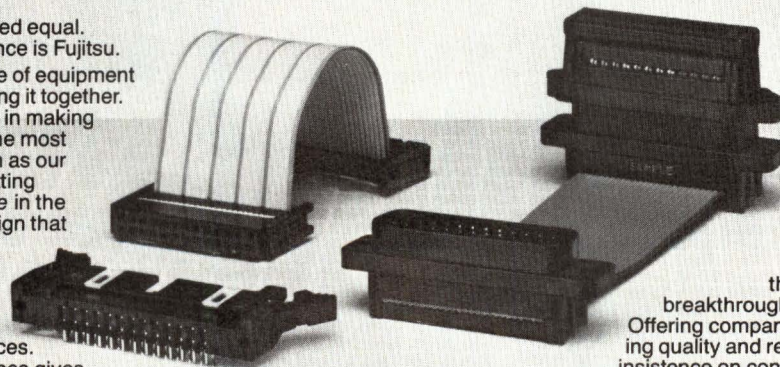
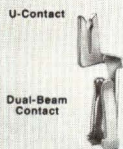

PC Board Transition; D-Subminiature; Mini-Socket and Receptacle.

Whatever your specific requirements, we'll work closely with you to find the right connector out of our existing line. Or if you have a design problem, we'll customize a design solution with a technical wizardry unmatched in the industry.

For years, Fujitsu has been on the leading edge in developing breakthrough, problem-solving technology. Offering companies, worldwide, uncompromising quality and reliability—the result of Fujitsu's insistence on controlling, in house, every aspect of the design and manufacturing process. And delivering—with the highest level of service and absolutely competitive prices.

Find out more about the World-Class Flat Cable Connectors from Fujitsu. Contact your *value added* Fujitsu Distributor or contact Fujitsu directly.

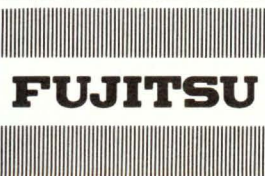

World-Class Components
Part of Tomorrow's
Technology

Component Division Fujitsu America, Inc.
918 Sherwood Drive, Lake Bluff, IL 60044
(312) 295-2610 Telex: 206196 TWX: 910-651-2559

CIRCLE 146

ESCAPE FROM THE REEL WORLD.

If you're faced with backing up today's high-capacity disks, you know the available alternatives haven't been too attractive.

Until MegaTape came along.

The inexpensive, book-sized MegaTape cartridge stores 330 megabytes in both streaming and start/stop modes. And unlike the 8 reels of conventional 9-track tape it replaces, it gives you 30-second average access to any file in the cartridge.

Best of all, the compact MegaTape drive costs under \$3,000 in OEM quantities, and uses standard controllers. And the design is so elegantly simple, reliability is outstanding. It's fast becoming the new industry standard for high-capacity backup.

So if you're looking for an escape from all the problems of the reel world, call MegaTape today. We'll show you the easy way out.



**Call Gary Webb, Vice President,
Marketing at (213) 357-9921**

MegaTape Corporation, P.O. Box 317
1041 Hamilton Road, Duarte, CA 91010-0317

 **megaTape**
The great leap forward in backup.

CIRCLE 29

IBM packs high density circuits in and lets them breathe

Packaging plays a critical role in the computational performance of IBM's mid-range 4381 processor. As a result, the new computer provides

up to three times the performance of its predecessor—the IBM 4341—while not requiring air conditioning for cooling. The company uses an air-

impingement cooling technique that yields twice the million instructions per second (MIPS) per kilowatt of power that was obtained from the 4341 machine. As a result, the individual power densities at the component level increased fivefold.

The densely packed circuits eliminated the need for an entire level of packaging. As opposed to the chip-on-module-on-card-on-board hierarchy used in the 4341, the 4381 has the chip mounted in modules. These modules are in turn stacked on a single board, thereby eliminating the card entirely. To top it off, the 4381 has twice the number of circuits in each module that the 4341 had on a card. More than 200,000 circuits are interconnected in 22 air-cooled modules. Three major components make up each module: a cooling assembly, the substrate chip carrier, and up to 36 chips containing about 700 circuits.

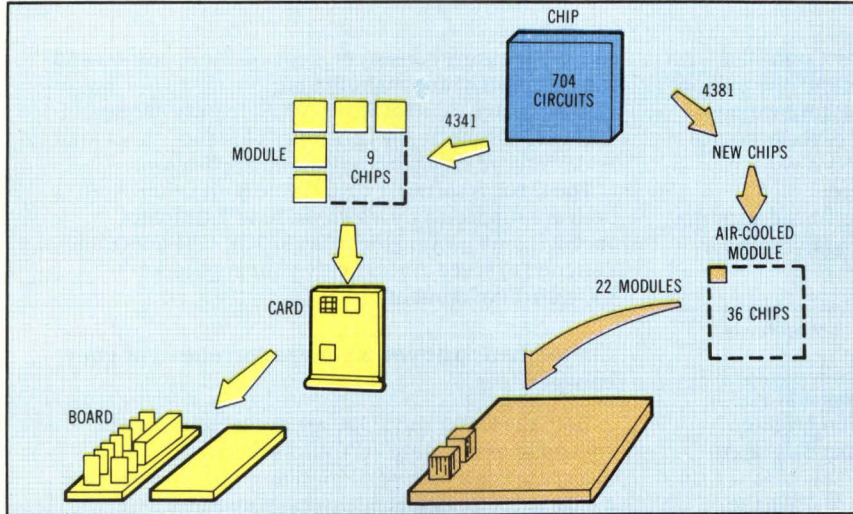

By implementing a novel packaging technique, IBM engineers were able to eliminate the card, which is still part of the 4341 computer package. More than 200,000 circuits are interconnected on the 4381 board. This is twice the number that was wired on the 4341 board.

(continued on page 51)

OUTSTANDING STAND-ALONE BOARDS.

SMC's Stand-Alone boards stand out in the crowd. Our **HAWK I** Video Terminal Board provides all the circuitry to build a "SMART" CRT Terminal, featuring enhanced video attributes and screen editing capabilities. Our **ARCNET-LINK** Board connects any computer with an RS-232 port to a high-performance ARCNET® local area network. For complete details, contact Standard Microsystems Corporation, 35 Marcus Boulevard, Hauppauge, NY 11788 (516) 273-3100.

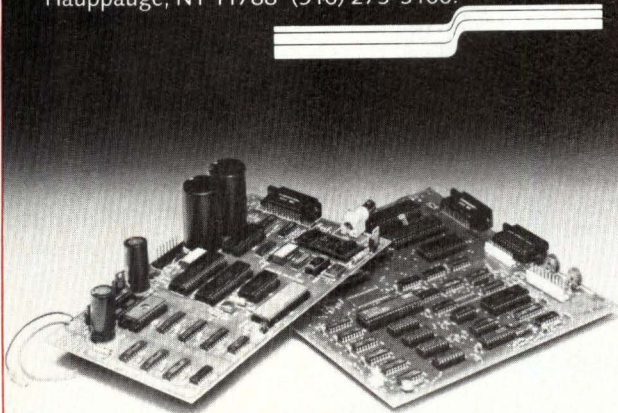

STANDARD MICROSYSTEMS. THE ONE TO WATCH.

ARCNET® is a registered trademark of the Datapoint Corporation

NOW IBM-TYPE PERSONAL COMPUTERS CAN GO PUBLIC.

SMC's **ARCNET-PC** board provides a simplified interface between the IBM® Personal Computer (PC) bus and an ARCNET® token passing local area network. It connects up to 255 computers and permits them to share disk files and printer resources, as well as send electronic mail to any system on the network. It does all this at a high performance 2.5 Megabit data rate, yet at a low cost due to the use of SMC's VLSI local area network chip set. For complete details, contact Standard Microsystems Corporation, 35 Marcus Boulevard, Hauppauge, NY 11788 (516) 273-3100.

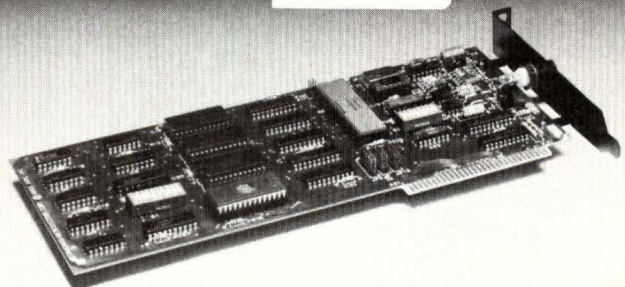

STANDARD MICROSYSTEMS. THE ONE TO WATCH.

IBM® is a trademark of the International Business Machine Corporation
ARCNET® is a registered trademark of the Datapoint Corporation

LET METHEUS OEM GRAPHICS PUT YOU A GENERATION AHEAD

First we brought you the Ω 400 Display Controller, with 1024 x 768 resolution, 8-bit planes and one million pixels/second vector drawing speed. This innovation introduced state-of-the-art color graphics performance from a single circuit board, providing OEMs with the ultimate in reliability, flexibility and price.

Now, Metheus has moved even further ahead with the Ω 500, first of a new generation of color graphic display controllers.

Ω 500: New standards in resolution, refresh and ergonomics. Still on a single board.

The Ω 500 Display Controller sets a new standard in graphics display ergonomics, bringing you brighter, crisper images and truly flicker-free displays. It has the highest resolution available, 1280 x 1024 at 60Hz non-interlaced refresh, the rate needed to drive the latest 100MHz monitors.

Ω 500's bit-slice processor supports drawing speeds ranging from 1.5 million to 120 million pixels per second.

And, once again, Metheus' advanced graphics technology is neatly packaged on a single board for exceptional reliability and efficiency. On-board signature analysis circuitry and extensive self-testing

capability ensure consistent, dependable operation and fast diagnosis of any malfunction.

A Writeable Control Store (WCS) feature allows OEMs to customize the controller's instruction set for a wide range of specialized customer applications.

The Ω 500 is software compatible with Ω 400. And, both are supported by Metheus' Axia™ Graphics Package, built around the ACM SIGGRAPH CORE and designed to speed and simplify your application software development.

Let Metheus put you a generation ahead of your competitors.

Both the Ω 400 and Ω 500 are available as display controller or integrated graphics subsystem incorporating a high resolution monitor. And both are available for immediate delivery in quantity.

If color graphics are a part of your product's future, you owe it to yourself and your customers to talk to Metheus today.

METHEUS

Metheus Corporation, P.O. Box 1049,
Hillsboro, OR 97123, (503) 640-8000

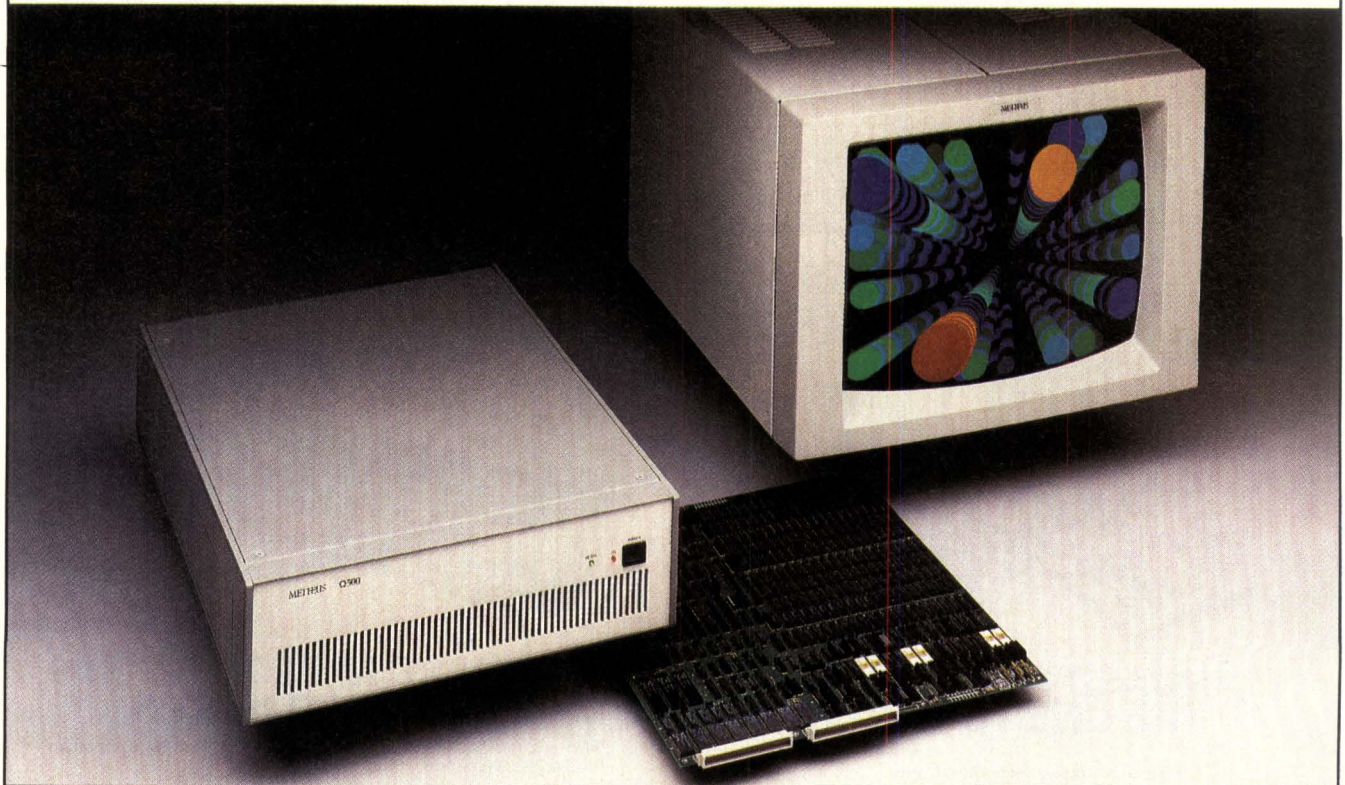

High density circuits (continued from page 49)

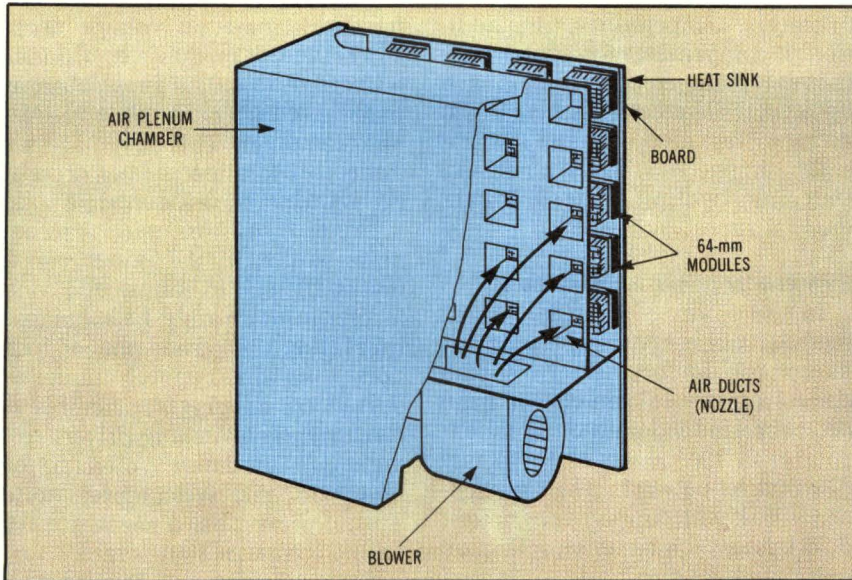

Cooling this compact mass is an air impingement mechanism with a blower that directs air simultaneously through nozzles. The air hits the circuit board in a perpendicular direction.

To cool these circuits, a blower supplies room air to a plenum chamber and directs the air simultaneously through nozzles (arranged

in parallel rows) to all the modules plugged on the circuit board. Air impinges on the modules in a direction perpendicular to the circuit

board at velocities over 10 m/s. It then exits near the base of each heat sink at the low velocity of 1.5 m/s into channels that lead to the periphery of the computer console. There are two primary advantages that parallel impingement has over serial cooling, according to IBM engineers. First, each module receives fresh air without having been heated by adjacent modules. Second, no air conditioning is required.

Specially designed heat sinks further enhance the external cooling of the modules. In turn, chips in each module are cooled again in parallel with direct heat pads provided by the thermal paste placed between each chip and the module cap. The 4381 module can accommodate up to 36 chips in a 6 x 6 arrangement on a 64-mm ceramic substrate. High powered chips are judiciously placed on the substrate based on thermal considerations. It is then solder-sealed against a ceramic cap that is fitted with an aluminum heat sink.

(continued on page 52)

S100 CONTROLLER BOARDS BUILD MORE VERSATILE SYSTEMS.

SMC's S100 controller boards present new opportunities in system design. Our **QSI0S100** board provides 4 independent serial I/O channels for simultaneous use of a variety of peripherals. The **FDCS100** board controls up to 4 floppy disk drives for removable mass storage capability. The **VRAMS100** board adds advanced video display capabilities, including smooth scrolling and double-height, double-width data rows. Our **ARCNET®-S100** board links up and controls a network of up to 255 computers. For complete details, contact Standard Microsystems Corporation, 35 Marcus Boulevard, Hauppauge, NY 11788 (516) 273-3100.

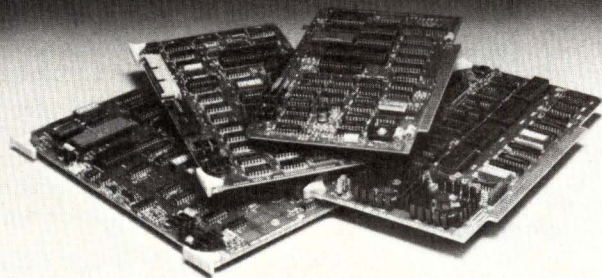

STANDARD MICROSYSTEMS. THE ONE TO WATCH.

ARCNET® is a registered trademark of the Datapoint Corporation

CUSTOM CONTROLLER BOARDS MEET UNIQUE STANDARDS.

Whatever your needs are in a controller board, SMC can meet them. We have the capability to modify our standard board products to your own unique specifications. Since we use the latest VLSI technology, we can usually do it faster, more reliably and at a lower cost than anyone else. In fact, in the last year, we've designed custom boards for the airline, banking and medical instrumentation industries. Now let us show what we can do for you. For complete details, contact Standard Microsystems Corporation, 35 Marcus Boulevard, Hauppauge, NY 11788 (516) 273-3100.

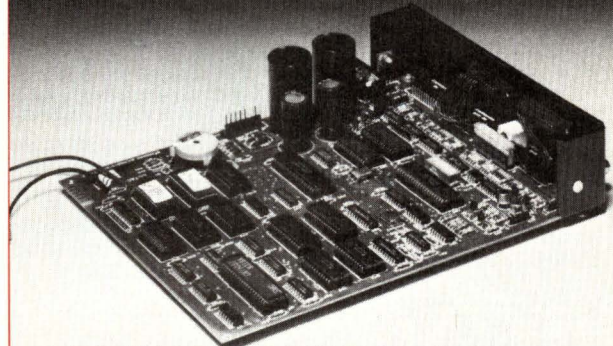

STANDARD MICROSYSTEMS. THE ONE TO WATCH.

High density circuits

(continued from page 51)

IBM engineers say that they owe much of the success of the 4381's heat dissipation to computer modeling that was done during the design stages. The modeling helped engineers decide how to partition and place the chips—to remain below maximum allowable junction temperatures, and above the specified minimum temperature. In the 4381, some chips are qualified to 90°C, others to 85°C, and all are specified not to operate below 25°C.

For this type of configuration, high powered chips are designed for placement on the module's periphery to take advantage of the proximity to the cap walls. These walls provide additional cooling paths to the heat sink. In the same manner, chips are allocated according to computed specifications to minimize temperature differences between them. This also reduces electrical noise.

The thermal model was verified against measurements made on actual modules. It can predict beginning-of-life and end-of-life

operating temperatures. In addition, it compensates for appropriate thermal parameters as determined by several different tests performed on many test modules. The tests include impact, vibration, shock, thermal cycling, mechanical/thermal shock, and others.

High density means minimum noise

In such a highly integrated module, noise control becomes of paramount importance. Noise can come from several sources, and can act either individually or simultaneously, in the power or the signal distribution network. The IBM engineers dealt with four types of noises: dc drops, switching noise, reflection noise, and coupled noise.

In general, circuits must be able to tolerate dc drops in the power distribution network in addition to any ac noise generated in the package. Efficient placement of power pins optimizes dc drops. In the 4381 module, each chip site is supported by exactly seven power pins and all

have the same dc voltage drops. Thus, the 4381 module's dc drops are 44 percent less than those observed in the predecessor module in IBM's 308X computer. This advantage was traded off to allow greater drops in PC board and more on-module noise.

Driver transistors cause a second noise source in the power supply that is difficult to control and could in this instance only be minimized by placing the power pins at locations that would cancel mutual inductances. Keeping the number of concurrently switching drivers to a minimum can limit the effect of this noise on the system-level noise. This, however, has a negative effect on the computer's MIPS rate.

Both reflection and coupled noise are a result of a poor signal-distribution network. Reflection noise was greatly reduced by the package's sheer density. In terms of reflection noise exposure, the 4381 is a vast improvement over the 4341. This is due, in part, to the increased number of circuits on a first-level package. Couple that with no cards and just one board, and the result is fewer transmission line-type problems.

Mutual capacitances and inductances of nearby conductors cause coupled noise. In turn, active lines coupling into a quiet line can cause false switching. IBM claims that rules have been written for its design automation system to limit coupled noise. Power switching noise and coupled noise can occur simultaneously. But, in terms of system noise tolerance, if the sum of the four noise sources remains below the individual circuits' noise tolerances (but not so low that it causes the machine to operate below its potential), then the computer is said to be working at its highest efficiency.

In general, as computers become more integrated and clever packaging techniques are found (eg, the 4381 system) engineers must pay very close attention to noise allocation from the inception of their design.

—Nic Mokhoff, Senior Editor

Low Cost Microprocessor Development System —

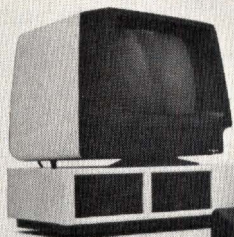

Your Computer —

Our Emulator!



Huntsville Microsystems offers a line of high performance in-circuit emulators and linking software packages which will turn any computer into a full microprocessor development system. The emulators feature real-time transparent emulation, mappable memory, hardware breakpoints, RS232 interface, upload/download hex files and complete debugging facilities. The units can operate stand-

alone with a CRT or when combined with the power of your computer form a full microprocessor development system.

Software packages are available to allow operation with any CP/M™ or ISIS™ system including the Intel™ iPDS™. Currently, in-circuit emulators are available for the 8085, Z80™ and NSC800. Prices start at under \$2000. Write for complete specifications.



Huntsville Microsystems, Inc.
8200 South Memorial Parkway,
P.O. Box 12415
Huntsville, AL 35802

(205) 881-6005

Z80 is a registered trademark of Zilog, Inc. CP/M is a trademark of Digital Research.
ISIS, Intel and iPDS are registered trademarks of Intel Corp.

February Preview
Special Report on
Data Communications

*“When SSI/MSI
isn't enough, and
gate arrays are too much,
the logical choice is a
short circuit.”*

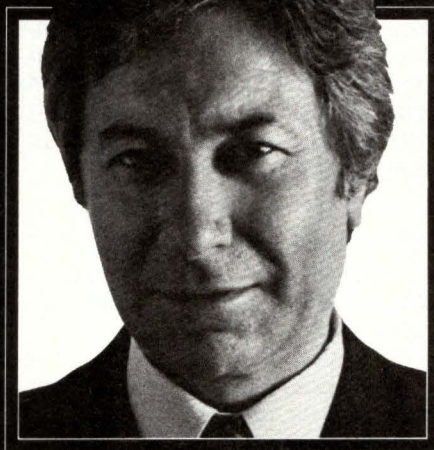

*— Napoleone Cavlan
Director of New Product Development,
Bipolar Memory Division*

“Signetics short circuits. Simple logic says it’s time to take a shortcut.”

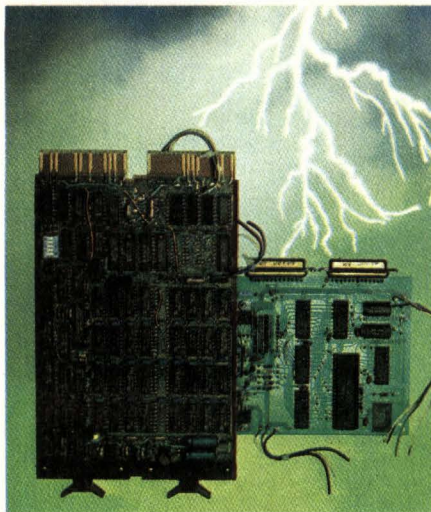

Take the shortcut! More than 60 SSI/MSI devices have been replaced by five Signetics short circuits. Even with a smaller board, there's still plenty of room for other part types.

We know all about the expanse of SSI/MSI. And the expense of gate arrays. Because we sell plenty of both.

But we also bridge the gap between them with IFL (Integrated Fuse Logic), otherwise known as short circuits. That means you can have customized logic. Without the custom prices or lead times.

IFL takes user-programmable logic far beyond programmable read only memory and programmable array logic circuits. It provides a high level of integration. Flexibility. And ease of use. All this adds up to dramatically lower parts

count. Improved reliability. Lower inventory costs. And shorter design cycles. Just for starters.

Programming is quick and easy, too. IFL devices are made up of logic elements joined by a selectable interconnect system. All connections and macro functions are completely programmable.

If you can write a Boolean equation, you're home free. Just define your system in terms of the equation and enter it at a CRT terminal for downloading to your PROM programmer. Blow the fuses, and your logic circuit is ready. As simply and quickly as that.

“They blow everything else right out of the water.”

No matter what other devices you stack up against our IFL circuits, there's no contest.

Compared to TTL, they can cut your PC board size and pin count often by as much as 90%, and make the system more reliable in the process.

Compared to gate arrays, IFL circuits give you shorter development cycles, since it takes about 30 seconds to program one of our parts versus 6 to 8 weeks to make a gate array mask. They also give you lower initial cost, less design risk, and off-the-shelf availability.

Our IFL circuits can even give you programmable output levels. The most useable P-terms per output. The most inputs and outputs.

And the most straightforward programming of any logic device in the industry. Complete with programmable AND and programmable OR arrays in the same device.

These circuits are among the most complex LSI products made today. But they're manufactured on the same bipolar fab line which recently demonstrated 54 ppm mechanical and 0 ppm electrical AOQ (Average Outgoing Quality) — an industry low.

We're applying this knowhow to our IFL. So you can be sure of the same high quality standards.

“You won't believe all the things they can do.”

They're so flexible, you can get everything you need from just three basic IFL circuits: our simple Field Programmable Gate Array (FPGA), Field Programmable Logic Array (FPLA) and Field Programmable Logic Sequencer (FPLS). All of which come in 20, 24, and 28-pin packages.

By stocking that basic inventory alone, you can program your own devices to perform an amazing variety of functions.

With just the 82S151 FPGA, for instance, you can get memory mapping, fault monitoring, address decoding for peripheral selection, and random gating functions.

You can use our 82S153 FPLA in CRT display systems, code conversion, microprogramming, character generation, data secu-

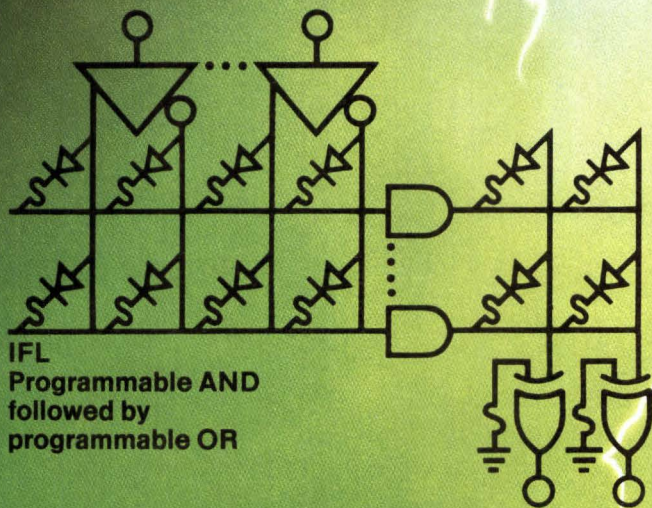

IFL
Programmable AND
followed by
programmable OR

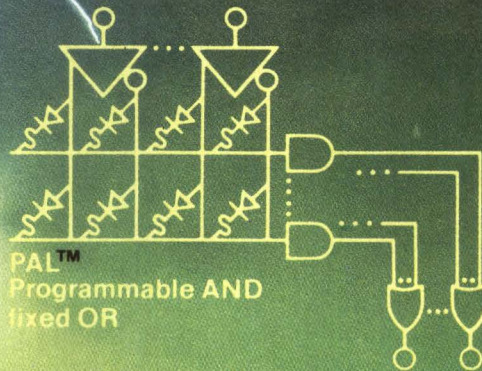

PAL™
Programmable AND
fixed OR

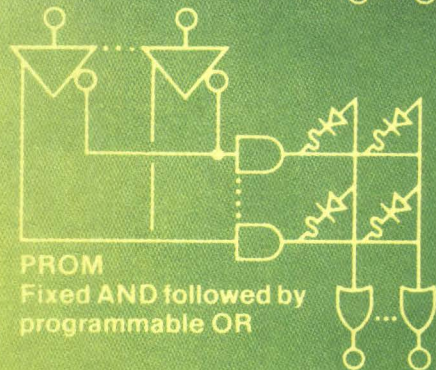

PROM
Fixed AND followed by
programmable OR

rity encoding, frequency synthesis, interfacing, and random logic replacement.

And then there's our 82S159 Field Programmable Logic Sequencer, the newest member of our FPLS family. It can replace more than two dozen small and medium-scale TTL logic circuits, and also directly replace the 16R8 circuit.

Its exceptionally broad flexibility makes this FPLS ideal for a wider-than-ever range of functions. Including synchronous up/down counters, shift registers, random sequential logic, bidirectional data buffers, priority encoder/registers and bus arbiters.

"We'll help you take the best possible shortcut."

We've developed a number of

comprehensive aids that explain the advantages of short circuits. Including descriptive product application notes. A complete new Data Manual. Software brochure. And even a colorful wall chart with individual product summaries and analyses of the various approaches to user-programmable logic.

We give you all kinds of one-to-one help, too. From IFL seminars to programming support from our distributors, and direct support from our Field Application Engineers nationwide.

So no matter what you need, we're ready to help. But however you decide to get into short circuits, we think you should do it soon. Because IFL is such a logical choice that it's bound to give someone a big jump

on their competition. And that someone might as well be you.

I'd like a short course on short circuits. Send me more facts.

Name _____

Title _____

Company _____

Division _____

Address _____

City _____

State/Zip _____

Phone _____

Mail to:
Signetics Corporation, MS 2527,
811 E. Arques, P.O. Box 3409,
Sunnyvale, CA 94088-3409

CD 1/1-M4

signetics

A subsidiary of U.S. Phillips Corporation

Introducing the with more

Real-time. A world where response times are measured in microseconds and performance is the only criteria.

In the hectic world of real-time, time waits for no man, woman or computer.

That's why you need a computer operating system that takes care

of business now, not later.

Computer-

Automation's

CARTOS is the answer.

The most powerful real-time operating system ever created to meet the challenge of all your industrial and commercial real-time applications.

From oil wells to nuclear power plants, robotized assembly lines to transportation systems, CARTOS runs them all—smoothly, efficiently, quickly. And more cost-effectively than any other system available.

Here's why:

Fast task switching time.

CARTOS cuts response time dramatically with the fastest context switching time around—150 μ sec.

The result? Critical events are serviced within the available time. It all adds up to peace of mind.

Virtual machines.

CARTOS makes your computer into 64 virtual machines. That means you have the whole computer

to yourself even while sharing it with 63 other virtual environments.

So you get more capacity with less interference.

Simultaneous development and debug.

Other systems require two separate computers to develop and debug on-going programs. CARTOS gets both jobs done all by itself. Up to ten programmers can work on-line even while CARTOS executes a large number of real-time tasks. So your program-

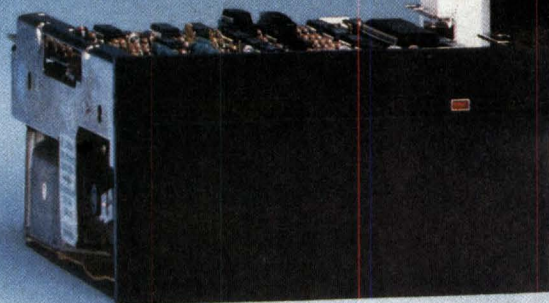

real-time system real value.

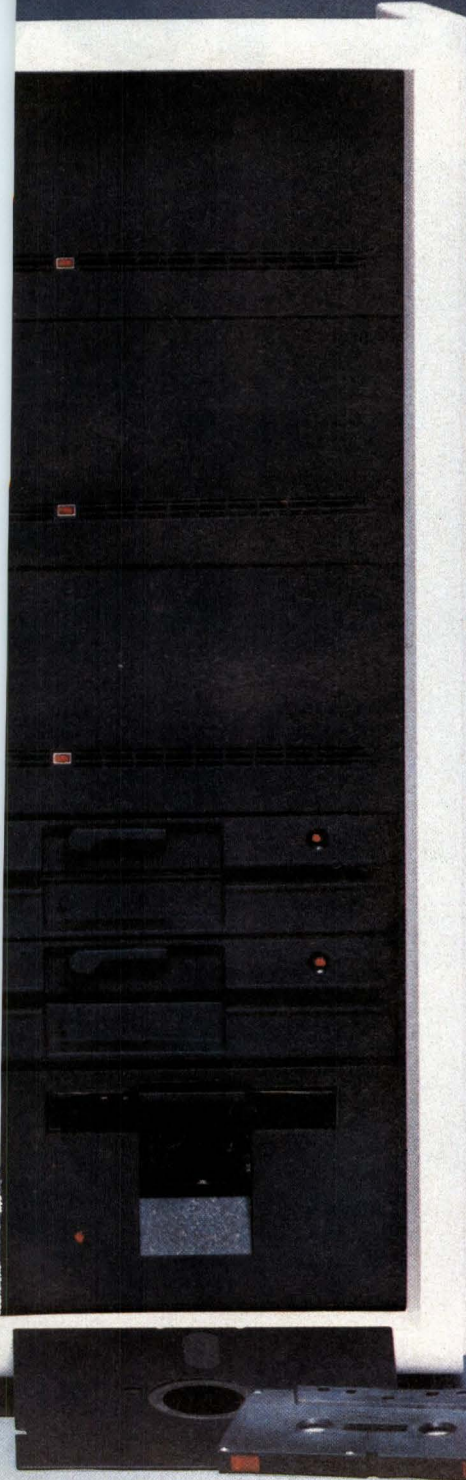

mers don't waste time waiting in line.

Super sysgen speed.

CARTOS knocks off in minutes what it takes other systems hours to accomplish. Our benchmark tests prove it. Faster sysgen means your productivity goes up while your costs go down.

Compatibility.

CARTOS' impressive development capabilities are compatible with ComputerAutomation's entire line of minicomputers. **dataCASE/5.**

Best of all, CARTOS runs on a family of low-cost, flexible minicomputer systems called **dataCASE/5.** **dataCASE/5** supports a large variety of CPUs and storage media. Floppies. Winchester. Streaming tape. Use any media you want in any combination you choose up to 1/2 gigabyte of capacity. With a 45 MB tape backup.

And you can put it wherever you want it. Lightweight and compact, **dataCASE/5** sits on your desk, on the floor

or in a rack. And when you want to expand, it's easy and fast.

When you don't have time to lose, consider the real-time system with more real value. **CARTOS. dataCASE/5.** From ComputerAutomation. We've been providing real-time solutions to the OEM world for 15 years. With 50,000 installations to prove it.

Why not tell us about your real-time needs by filling out and mailing the coupon today. Or give us a call.

Because time is running out.



ComputerAutomation®

NAKED MINI. Division

18651 Von Karman, Irvine, CA 92713.
PH: (714) 833-8830, Ext. 353. TWX: 910 595 1767

It's about time.

- I want to discuss my application. Please have a sales representative call me.
- I'm interested in more information. Please send the latest brochure describing **CARTOS, dataCASE/5** and other real-time offerings.

NAME _____

COMPANY _____ TITLE _____

ADDRESS _____

CITY _____ STATE _____ ZIP _____

PHONE _____

Fujitsu believes deserves lot

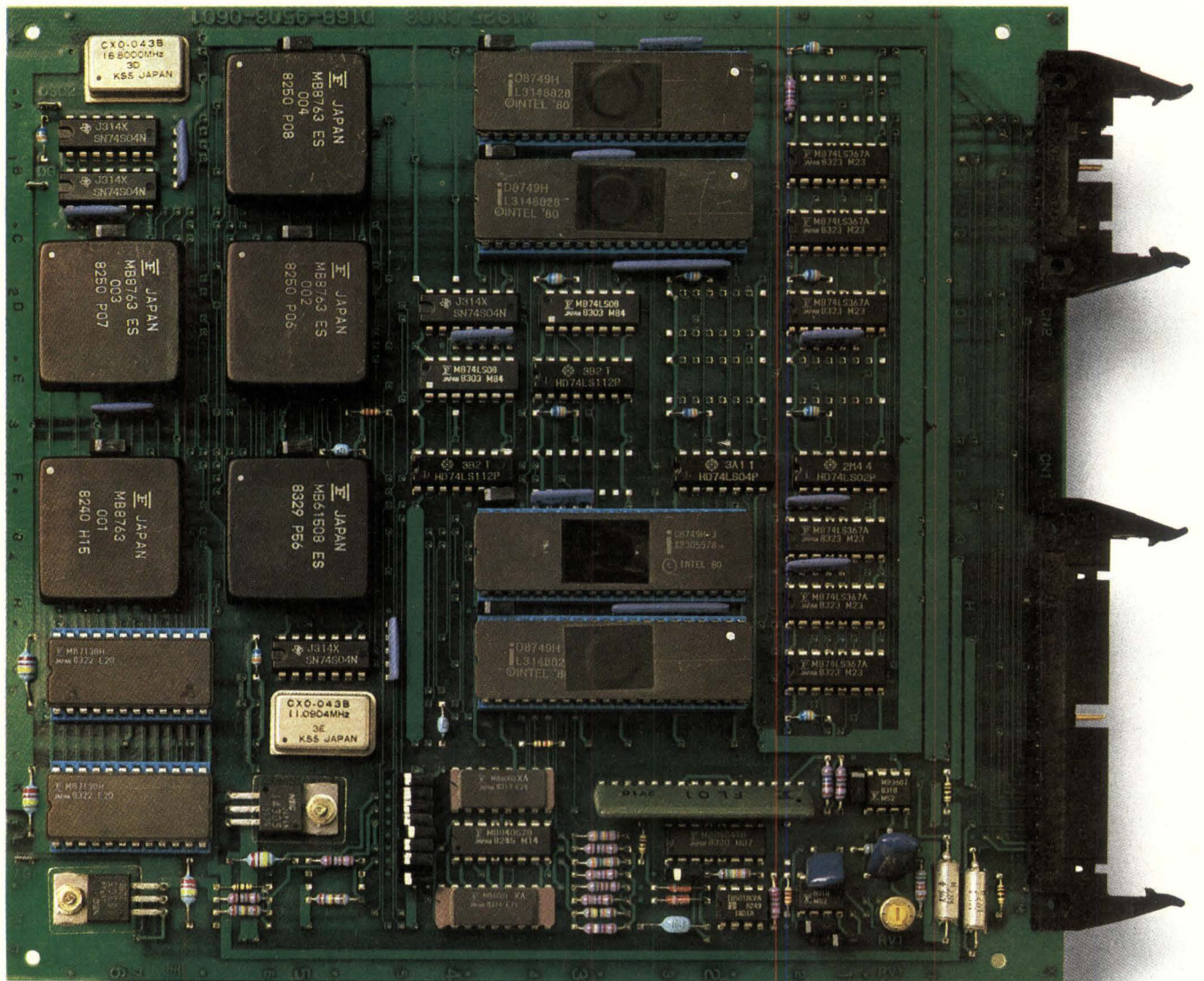

The world's first 14.4 kilobit modem card; superior reliability in a compact package. 9,600bps & 4,800bps core modems and stand-alone modems also available.

Yes an OEM deserves fast talk.

That's why Fujitsu now offers the world's *first* 14,400 bit per second modem card, along with companion 9,600 bps and 4,800 bps core modems. All three single PC boards employ custom digital signal processors. And from a standpoint of versatility, the units are compatible with *any* type of equipment.

By offering your customers the fastest, most reliable, and economical modem, you're not only offering state-of-the-art technology, but a product that is backed by a world leader in the telecommunications and computer industry.

We also realize that diversity sells your products and increases your profits. So, Fujitsu not only offers core modems, but also offers a full line of stand-alone modems.

Fujitsu modems meet the future head on. And that's the kind of fast talk you deserve.



FUJITSU

Fujitsu America, Inc. ♦ Data Communications Division ♦ 1945 Gallows Road
Vienna, Virginia 22180 ♦ (703) 356-5758

CIRCLE 37

Digi-Data Series 2000

THE COOL STREAMER

Digi-Data Series 2000 streamers put the heat on the competition — and off the tape.

Unlike our competitors, whose streamers draw air over hot components before blowing it into the tape compartment, the Series 2000 keeps its cool by pulling air from outside the rack directly across the entire tape path. The cooling fan moves large amounts of cool air over the tape, keeping it below the easily exceeded ANSI limit of 90°F regardless of rack temperature. And by exhausting air outside of the rack, the streamer does not increase rack temperature.

This cool tape path is just one of the reliability features Digi-Data designed into the Series 2000. Solid state sensors and microprocessor controlled calibration and power-up diagnostics are standard. Step-write, microprocessor controlled read electronics and extended deskew buffer make 3200 bpi operation more reliable.

And Series 2000 performance matches its reliability. With speeds up to 125 ips for 1600 bpi and 62.5 ips for 3200 bpi, the streamer can back up 92M bytes on a single tape reel in under 10 minutes (including rewind). A unique adaptive streaming feature enables the Series 2000 to adjust its tape speed to match the data rate.

Series 2000 is just one of Digi-Data's full line of 1/2" and 1/4" tape drives for streaming and conventional start/stop operation.



**DIGI-DATA
CORPORATION**

... First In Value

8580 Dorsey Run Road
Jessup, MD 20794

Tel. (301) 498-0200
TWX 710-867-9254

In Europe contact:

Digi-Data Ltd.
Kings House
18 King Street
Maidenhead, Berkshire
England SL6 1EF

Tel. 0628 29555-6
Telex 847720

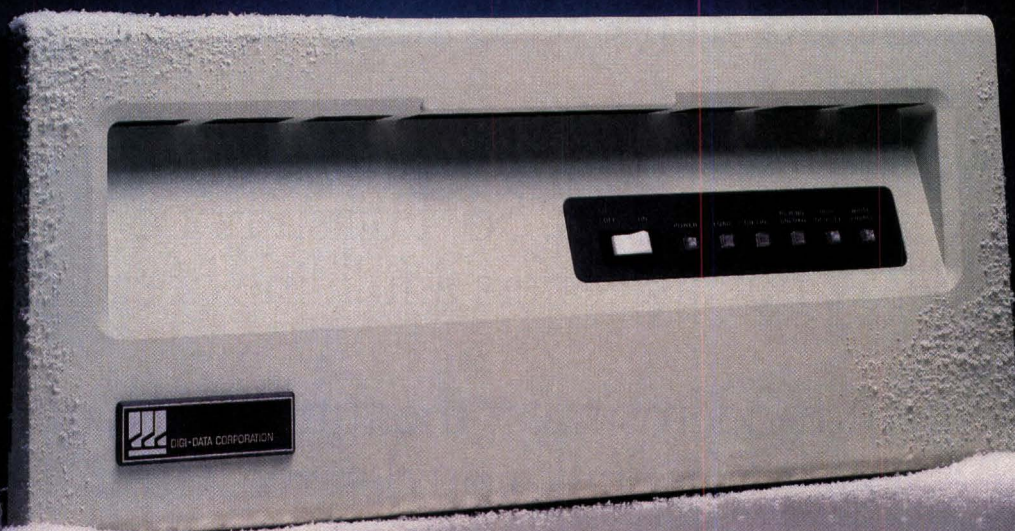

ISSCC '84

International Solid State Circuits Conference

San Francisco Hilton Hotel,

San Francisco, California

February 22 to 24, 1984

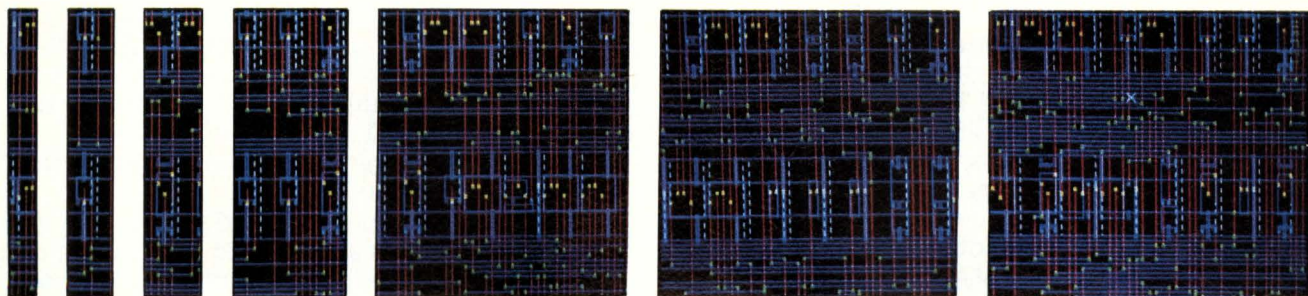

Courtesy of LSI Logic Corp

Next month's International Solid State Circuits Conference will plumb advanced prototypes in bipolar, MOS, and GaAs technologies. Capitalizing on design rules as low as $1\ \mu\text{m}$, memory chips with ultrafast access times reach densities of 1 Mbit. Moreover, growing ranks of 256-Kbit dynamic RAMs clock access around 80 ns, while 64-Kbit static RAMs are closing in on 20 ns. Other chips to watch for are a 32-bit VLSI superminicomputer CPU with 1,220,500 transistors and faster, higher capacity erasable PROMs.

Submicrometer design rules, picosecond gate delays, and three-dimensional architecture remain for the most part in theoretical discussions. Meanwhile, CMOS continues to solidify its posture alongside NMOS as a high performance technology, and GaAs is coming into sharper focus as a potential player in high speed digital circuits.

Circuit integrators who are puzzling over reliable ways to scale semiconductor technology further are about to get a boost. This year, standard power supply voltages for ICs are expected to drop from 5 to 3.3 V, ± 0.3 V. Based on impending JEDEC approval of this lower power standard, many designers are already planning in earnest for the next round of integration. At its lower limit, the proposed standard matches high performance CMOS; at its upper limit, established 5-V technologies.

Inevitably, memory technology is in the vanguard of semiconductor development because of its device regularity and testability. Right now, researchers from Stanford University (Stanford, Calif) project a 16-Mbit density ceiling for VLSI DRAMs. From the performance standpoint, the Stanford group will present an analytic model representing estimated limits of NMOS and CMOS devices. Minimum channel lengths of 0.14 and $0.40\ \mu\text{m}$, corresponding to logic gate delays of 19 ps for CMOS and 103 ps for NMOS, are predicted.

Shrinking linear dimensions by 36 percent, Intel Corp (Santa Clara, Calif) scientists have scaled a CMOS chip down to $1.5\ \mu\text{m}$. They did this by integrating existing NMOS devices with an n-well CMOS approach. Bulk p-substrates replace p-epitaxy on p+ substrates to reduce latchup

susceptibility. In this way, an 8-bit microcomputer is said to achieve minimum gate delays of 190 ps.

The Hitachi Central Research Laboratory (Tokyo, Japan) will analyze how it integrates 84-ps ECL with 320-ps I²L technology. A side wall base contact structure is used to make the ECL and I²L circuits, whose gate areas measure 3500 and $112\ \mu\text{m}^2$. Members of the Institut für Theoretische Elektrotechnik (Aachen, Germany) form nonsaturating and merged current mode logic using up/down transistors. The chip displays a power-delay product of 0.1 pJ for power dissipation less than $50\ \mu\text{W/gate}$, and a minimum delay of 1.6 ns at $200\ \mu\text{W/gate}$.

Dense DRAMs speed up, SRAMs go CMOS

Over the last 10 years, DRAM design rules shrank from 10 to under $2\ \mu\text{m}$ while designers grappled with speed/density trade-offs. Today, the 256-Kbit plus league is filling up with CMOS and NMOS DRAMs, and putting access times under 100 ns into the contract. In due course, this increased density may force the familiar $\times 1$ address-multiplexed configuration to yield ground to $\times 4$ and $\times 8$ organizations.

Auxiliary onchip functions also distinguish newcomer 256-Kbit RAMs. Staff from Siemens AG (Munich, Germany) will describe a double poly TaSi₂-gate 256-Kbit DRAM with 20-ns nibble mode and automatic descrambled testing. Colleagues from IBM Deutschland (Boeblingen, Germany) will present an 80-ns, 256-Kbit n-channel metal-gate DRAM with four selectable data I/O buffers. This chip configures 64-K $\times 4$, 128-K $\times 2$, or 256-K $\times 1$, with parallel or serial 20-ns data transfer rate.

Intel Corp (Aloha, Ore) will present a sub-100-ns 256-Kbit DRAM constructed from CMOS III technology with a $1\text{-}\mu\text{m}$ channel length. The chip dissipates $25\ \mu\text{W}$ standby power and offers 25-MHz ripple mode and static column mode. Beyond that, Hitachi, Ltd (Tokyo, Japan) will highlight an externally clocked 32-K $\times 9$ pseudostatic RAM. The 288-Kbit chip uses a $6.8\text{-}\times 13.6\text{-}\mu\text{m}$ n-channel dynamic transistor cell, with $5.58\text{-}\times 9.86\text{-mm}$ die size.

An experimental 1-Mbit DRAM with an onchip voltage limiter will be the subject of another Hitachi report. The 5-V NMOS chip has a $21\text{-}\mu\text{m}^2$

cell; typical access time is 90 ns, cycle time is 260 ns, and power dissipation is 300 mW.

Demand for cooler, portable high performance systems is driving CMOS SRAM developers hard. The big news this year is Toshiba Corp's (Kawasaki, Japan) 46-ns, 256-Kbit chip. The 59.2-mm², 32-K x 8 CMOS SRAM is made from double-metal, double poly 1.2- μ m p-well technology. It displays 10-mW operating power at 1 MHz and 30- μ W standby power. Toshiba will present a second CMOS SRAM made with 1.2- μ m design rules. This one features bipolar sense amplifiers, and uses both CMOS and bipolar devices with double poly MoSi processing. The 64-K chip typically accesses in 28 ns and has a 20-nA standby mode.

The fastest 64-Kbit CMOS SRAM at the conference ticks off 20 ns during a typical address access. Hitachi, Ltd's 19.0-mm² chip uses 1.3- μ m gate MOS transistors, a pulsed-word-line technique, and p-well/bipolar technology. Power dissipation is typically 70 mW, given a 1-MHz cycle time.

Two 64-Kbit SRAMs follow 1.5- μ m design rules. A 25-ns, 30.9-mm² chip from NEC Corp (Kanagawa, Japan) is based on p-well CMOS technology featuring a double-metal poly load four-transistor memory cell. Fairchild Research Center's (Palo Alto, Calif) SRAM is a poly load 28.0-mm² chip using 1.5- μ m double TaSi p-well CMOS technology.

Inmos Corp (Colorado Springs, Colo) researchers will present a 30-ns, 64-Kbit CMOS SRAM using analog circuit techniques. This chip also features multistage decoding and a single polysilicon memory cell with buried V_{SS} line.

The other 20-ns access, 64-Kbit SRAM, made by IBM Research Center (Yorktown Heights, NY), is an NMOS chip configured 4-K x 16. Made with 1.7- μ m lines and single-level polycide, it features a four-transistor dynamic refresh memory cell and a 30-ns cycle time.

Nonvolatile memories diversify

The CMOS revolution is transforming nonvolatile memory as well as dynamic and static RAM techniques. EPROMs and ROMs are improving speed and density, but the many technologies used to implement electrically erasable PROMs may create a standardization problem.

This year's EPROMs range from 1 Mbit down to 256 Kbits, with corresponding access times of 200 to 125 ns. The densest, from NEC Corp (Sagamihara, Japan) is a fully static design using 1.2- μ m design rules. The chip's organization can be either 64-K x 16 or 128-K x 8, and programming voltage is about 13 V.

Advanced Micro Devices (Sunnyvale, Calif) will be showing its 150-ns, 512-Kbit NMOS EPROM. Double polysilicon floating gate technology is

realizing the densities of 64 to 512 Kbits; 1.7- μ m design rules allow a cell size of 36.6 μ m².

Seeq Technology, Inc's (San Jose, Calif) 125-ns, 256-Kbit EPROM is made from 1.5- μ m n-well CMOS on epitaxy. This results in a cell size of 37.5 μ m² and a die size of 180 mils square. The chip features 12- to 16-V programming and a 50-mW active power dissipation.

Exel Microelectronics, Inc's (San Jose, Calif) 4-K x 8 CMOS EEPROM achieves 55-ns access time through the memory array by using two memory cells per bit. Generating a differential signal on complementary bit lines reduces the voltage swing necessary for sensing.

Another Seeq chip using 1.5- μ m² n-well CMOS on epitaxy is a 5-V only 64-Kbit EEPROM. The device features an 85- μ m² two-transistor cell and 33,100-mil² die area. Address edge detection circuits result in a 100-ns typical access time with 50-mW active power dissipation.

Megabit capacity in an 80-ns PROM will be examined by Toshiba Corp (Kawasaki, Japan) designers. Their chip incorporates a through-hole programmed mask ROM cell and a fully static CMOS sense amplifier. Using double polysilicon p-well CMOS technology, the ROM achieves a cell size of 33 μ m².

Microprocessors and microcontrollers rev up

Without a doubt, 32-bit architecture is creating the framework for future advanced processor developments. At the same time, sophisticated 8- and 16-bit processors and controllers are dedicating powerful intelligence with onchip memory to myriad ancillary operations.

Researchers from the University of California, Berkeley, will analyze the characteristics of two scaled versions of their 32-bit, reduced instruction set computer. The 58-mm², 4- μ m version of this NMOS microprocessor runs at 8 MHz within 5 percent of expected speed and consumes 1.25 W. The 3- μ m, 32-mm² version operates at 12 MHz using 1.8 W.

Digital Equipment Corp (Hudson, Mass) will make three presentations to whet the appetites of 32-bit architects: a VLSI superminicomputer CPU, a microprocessor with onchip virtual memory management, and a bus interface chip. The superminicomputer processor consists of a five-chip set implementing 304 instructions. Design encompasses 1,220,500 transistors and a 220-ns microcycle. In addition, DEC will unveil a 140,000-transistor, 32-bit single-chip microprocessor that carries out 304 superminicomputer instructions. The chip measures 8.5 x 8.0 mm, and dissipates 3 W. The bus interface provides 600-ns data access, 13-Mbit bandwidth, and error detection. This 265- x 265-mil chip mounts on a 132-pin ceramic grid array and dissipates 3.5 W.

(continued on page 64)



1 TO 128.

1 KM AWAY.

WITH 1 CABLE.

AND ATTACH.

From Able.

With a single cable, an Attach* subsystem connects up to 64 terminals, in various configurations, to one or more host DEC computers. Additional Attach sub-systems will connect up to 64 more terminals.

And each single cable can span 1 km, about two-thirds of a mile, between any DEC Unibus host computer in the system and Attach, or between Attach subsystems.

Attach gives you much greater freedom in locating terminals and CPU's, while greatly reducing wiring, line costs, and power consumption.

In fact, Attach gives you much greater freedom in operating your entire system. That's because terminals can be dynamically configured with any CPU interfaced with the system, all at the touch

*Patent Pending

of a few keys. Terminals can be switched instantly, individually or in clusters, to the appropriate CPU.

MAKES OBSOLETE...OBSOLETE.

Attach reduces obsolescence by design and in practice. As Attach's capabilities are enhanced in the future, any new options you choose to add will easily interface with your existing system. Your system will simply get better, not outdated.

Whether you have 28 or 128 terminals, discover the simple way to attach them to your DEC Unibus CPU's, up to 1 km away. With one cable.

Discover Attach. No other long-line terminal support goes as far.

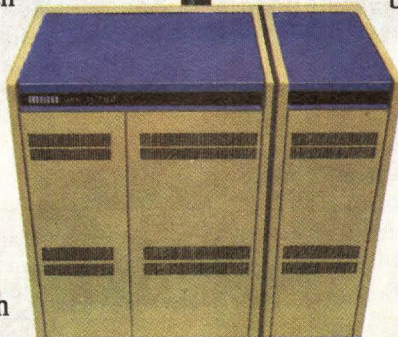

**ABLE
COMPUTER**

The communications specialists.

1732 Reynolds Avenue, Irvine, California 92714. Call toll free: 800-332-2253. In the Irvine area: (714) 979-7030. Or, TWX: 910-595-1729

DEC, Unibus and VAX are trademarks of Digital Equipment Corporation.

CIRCLE 39

(continued from page 62)

In addition, scientists from SGS-ATES (Milan, Italy) will detail their 8-bit, 5-V only single-chip microcomputer implemented in 4- μ m double poly floating gate technology. The computer carries 32 Kbits of ROM, 512 Kbits of RAM, and 512 Kbits of nonvolatile SRAM. Texas Instruments, Inc (Houston, Tex) researchers will examine a 16-bit digital communication controller with 2816 bytes of RAM. The chip features instruction fault detection, I/O parity check/generation, and special test modes.

Digital GaAs circuits progress

Presently, GaAs technology imposes speed-versus-function trade-offs that make its feasibility questionable in many computer system applications. Despite such concerns, gigahertz clock rates inspire designers to work around the functional limitation and capitalize on short gate delays for high speed digital applications.

A fourfold density improvement characterizes this year's GaAs SRAMs over those from last year. Fujitsu Laboratories, Ltd (Atsugi, Japan) will show a 3-ns, 4-K x 1 chip. Researchers will describe the tungsten-silicide gate, self-aligned technology responsible for this 700-mW SRAM. It features 1.5- μ m gates, E/D direct coupled FET logic, and 2- μ m line-width metallization. In addition, NTT Atsugi Electrical Communication Laboratory (Kanagawa, Japan) will present its own 4-K x 1 SRAM, with direct coupled FET logic. The 5-ns chip uses self-aligned implantation for the n+ layer. It also dissipates 700 mW.

Two GaAs gate arrays demonstrate present levels of functional complexity. TI (Dallas, Tex) will report on the design, fabrication, and performance of its 1-K heterojunction bipolar array. The I²L gate array has a base bar size of 3.55 x 3.80 mm², and contains 1024 internal gates, 64 programmable I/O buffers, and 8 power supply pads. Also, Toshiba Corp will highlight a 1050-gate array connected as a 6 x 6-bit parallel multiplier. The 350-mW chip performs 10.6-ns multiplies.

IBM General Technology Div (Essex Junction, Vt) researchers will compare gate array, mixed gate array, and custom integrated circuit design methods used to create a full-custom, 32-bit NMOS microprocessor. Onchip 5- and 3.4-V supply voltages and automated gate array design in parts of the chip achieve 230-ns speed and 2.8-W power dissipation. The IBM group will also present a CMOS logic circuit using 10,880 NMOS differential pairs. This approach generates performance comparable to conventional CMOS, and is suited to automated logic minimization and placement and routing techniques.

In semicustom array prototypes, as elsewhere, CMOS looms large. A 12,000-gate CMOS array with

10 Kbits of flexible memory will be detailed by Hitachi, Ltd spokesmen; the 2- μ m CMOS gate distributes transistors throughout the wiring region. In addition, Hitachi will cover a 16-ns array with 16-word x 8-bit RAM, and a 16-word x 10-bit first-in, first-out memory.

Toshiba Corp will be touting its 8370-gate, subnanosecond CMOS/SOS array, made using a 2- μ m Si-gate process. Typical propagation delay for the two-input NAND gate is 0.87 ns; the gate has a fanout of 3 and 2-mm metal interconnect loading.

The development of a 2- μ m poly gate CMOS array that combines digital gate array design with stacked-layout analog capability will be detailed by Stanford University researchers. The analog part contains up to 10 sections of a biquadratic switched-capacitor filter.

A team from TRW Defense Systems Group (Redondo Beach, Calif) and AT&T Bell Laboratories (Allentown, Pa) will present a VLSI delay commutator for fast Fourier transform processors. Made using 2.5- μ m CMOS standard cell technique, the 108,000-transistor circuit realizes data rates to 40 MHz. It has 12,288 shift register stages and about 2000 logic gates.

A 4-ns ECL field programmable logic array will be outlined by Fairchild Research Center and Fairchild Advanced Bipolar Div (Mountain View, Calif). The array configures 16 x 24 x (8 + $\bar{8}$) with true and complement outputs. Features include programmable vertical junction fuses and built-in test.

Spotlight on communications

Although ISSCC '84 will be a bit early to take the wraps off many telecommunication circuits now in development, several presentations may give a glimpse of what is coming. Among them, Seeg Technology, Inc will show its 10-MHz Ethernet serial interface chip made using 2- μ m n-well CMOS. The 99- x 115-mil Manchester encoder/decoder consumes 150 mW and uses a phase locked loop to decode data having 18-ns jitter. The transmitter drives a 78- Ω transceiver cable directly with less than 0.5-ns skew. Also, a cooperative effort between TI (Houston, Tex) and Racal-Vadic (Milpitas, Calif) has resulted in a 1200-bit/s quadrature phase shift keyed full-duplex modem chip. The 55,700-mil² die houses all Bell 212 and CCITT V.21, V.22, and V.23 functions.

—*Deb Highberger, Senior Associate Editor*

For registration information, contact Lewis Winner, 301 Almeria Ave, Coral Gables, FL 33134. Tel: 305/446-8193

(ISSCC coverage continued on page 66)

alpha

OMNIGUARD™

Extreme heat. Frigid cold. Chemical spills. Mechanical abuse. Moisture. Environmental hazards. Regardless of where or when you use cable, there can be risks. **OMNIGUARD** electronic cable, available only from Alpha, protects against those risks.

Alpha's **OMNIGUARD** is a unique series of state-of-the-art electronic cables that are hazard-matched to perform optimally even in the most hostile environments. Select the proper Alpha **OMNIGUARD** electronic cable, and you can bury it, without conduit. Immerse it in water. Run heavy equipment over it. Drag it. Splash it with oil, gasoline, alkali or acids. Use it under ground or in outer space. And nearly anywhere in between. Without risk.

Alpha's **OMNIGUARD** is available in five distinct cable constructions, utilizing specific materials for specific needs. Depending on your application, you can select the appropriate armor, shielding and jacket color options. And you can order Alpha's **OMNIGUARD** in quantities as small as 100 feet.

For more information, call your local Alpha distributor or write for your free Alpha **OMNIGUARD** catalog. It features detailed selection criteria which

will enable you to specify the right Alpha **OMNIGUARD** electronic cable for your most demanding requirements.



Optional ALPHALOC armor provides protection against extreme mechanical abuse.

IT COVERS THE RISK.

CIRCLE 40

alpha

ALPHA WIRE CORPORATION

711 Lidgerwood Avenue, P.O. Box 711, Elizabeth, New Jersey 07207 USA 201-925-8000
See us at Southcon Booth no. 1735

*(continued from page 64)***Technical Program Excerpts*****Session 1: Custom and Semicustom Design Techniques****Wed 9 am to 12:15 pm, Continental 1-4**

Chair: A. R. Newton, University of California, Berkeley

- 1/1 "An Integrated Modular and Standard Cell IC Design Method"
R. Kasai, K-n. Fukami, K. Tansho, H. Kitazawa, N. Miyaho, and S. Horiguchi, NTT Atsugi Electrical Communication Laboratory, Kanagawa, Japan
- 1/2 "A Comparison of Mixed Gate Array and Custom IC Design Methods"
W. K. Hoffman, R. A. Bechade, C. K. Erdelyi, and M. P. Concannon, IBM General Technology Div, Essex Junction, Vt
- 1/3 "Cascode Voltage Switch Logic: A Differential CMOS Logic Family"
L. G. Heller and W. R. Griffin, IBM General Technology Div, Essex Junction, Vt; and J. W. Davis and N. G. Thoma, IBM System Products Div, Boca Raton, Fla
- 1/4 "A Synthesis Program for Operational Amplifiers"
M. G. Degrauwe, Centre Electronique Horloger, Neuchatel, Switzerland; and W. M. C. Sansen, Catholic University/Leuven, Heverlee, Belgium
- 1/5 "Computer Generation of Digital Filter Banks"
P. A. Ruetz, S. P. Pope, B. Solberg, and R. W. Brodersen, University of California, Berkeley
- 1/6 "The Use of E-Beam for Random Access Read and Write of Digital Test Signals"
J. Jensen and K. Martin, University of California, Los Angeles

Session 2: Image Sensors**Wed 9 am to 12:15 pm, Continental 5**

Chair: R. P. Khosla, Eastman Kodak Research, Rochester, NY

- 2/1 "mos Imaging with Random Noise Suppression"
S. Ohba, M. Nakai, H. Ando, T. Ozaki, N. Ozawa, T. Imaide, S. Ikeda, T. Suzuki, I. Takemoto, and T. Masuhara, Hitachi Central Research Laboratory, Tokyo, Japan
- 2/2 "A Line Transfer Color Image Sensor with 576 x 462 Pixels"
J. L. Berger, L. Brissot, Y. Cazaux, and P. Descure, Thomson-CSF Electronic Tube Div, Cedex, France
- 2/3 "A 488 x 430 Interline Imager with Integral Exposure Control"
Y. T. Chan, O. R. Barrett, C. W. Chen, Y. Abendini, and D. D. Wen, Fairchild Camera and Instrument Corp, Palo Alto, Calif

- 2/4 "An Interline Transfer CCD Imager with a Half-inch Format"
Y. Matsunaga and N. Suzuki, Toshiba Corp, Kawasaki, Japan
- 2/5 "A 3456-Element CCD Sensor with Serpentine Shift Registers"
D. D. Wen, D. Reaves, S. Onishi, and J. Pendleton, Fairchild Camera and Instrument Corp, Palo Alto, Calif
- 2/6 "A 5732-Element 1.2-in. Linear CCD Imager"
N. Kadekodi, A. Claproth, A. Anyiwo, L. Sheu, J. Tandon, and A. Ibrahim, Xerox Microelectronics Center, El Segundo, Calif

Session 3: Digital GaAs Circuits**Wed 9 am to 12:15 pm, Continental 6-9**

Chair: A. Podell, Podell Assocs, Palo Alto, Calif

- 3/1 "A 1-K Gate GaAs Gate Array"
Y. Ikawa, N. Toyoda, M. Mochizuki, T. Terada, K. Kanazawa, M. Hirose, T. Mizoguchi, and A. Hojo, Toshiba Corp, Kawasaki, Japan
- 3/2 "GaAs Heterojunction Bipolar 1-K Gate Array"
H. T. Yuan, W. V. McLevige, H. D. Shih, and A. S. Hearn, Texas Instruments, Inc, Dallas, Tex
- 3/3 "A 3-ns GaAs 4-K x 1-bit SRAM"
N. Yokoyama, H. Onodera, T. Shinoki, H. Ohnishi, H. Nishi, and A. Shibatomi, Fujitsu Laboratories, Ltd, Atsugi, Japan
- 3/4 "A GaAs 4-Kbit SRAM with Direct Coupled FET Logic"
M. Hirayama, M. Ino, Y. Matsuoka, and M. Suzuki, NTT Atsugi Electrical Communication Laboratory, Kanagawa, Japan

Session 4: Data Acquisition Circuits**Wed 9 am to 12:15 pm, Imperial**

Chair: R. A. Blauschild, Linear Design, Inc, Los Altos, Calif

- 4/1 "A Bulk CMOS 20-MS/s, 7-bit Flash A-D Converter"
Y. Fujita, E. Masuda, S. Sakamoto, T. Sakaue, and Y. Sato, Toshiba Corp, Kawasaki, Japan
- 4/2 "An 8-bit, 100-MS/s Flash A-D Converter"
Y. Yoshii, K. Asano, M. Nakamura, and C. Yamada, Sony Corp, Kanagawa, Japan
- 4/3 "A Multi-Step Parallel 10-bit 1.5- μ s A-D Converter"
M. Kolluri, Signetics Corp, Sunnyvale, Calif
- 4/4 "A Ratio-Independent Algorithmic A-D Conversion Technique"
P. W. Li, M. Chin, P. R. Gray, and R. Castello, University of California, Berkeley
- 4/5 "A Self-Calibrating 12-bit, 12- μ s CMOS A-D Converter"
H-S. Lee, D. A. Hodges, and P. R. Gray, University of California, Berkeley
- 4/6 "A Trimless, 16-bit Digital Potentiometer"
P. Holloway, Analog Devices, Wilmington, Mass

*Program sessions are subject to last-minute changes.

(continued on page 68)

You can't save more.

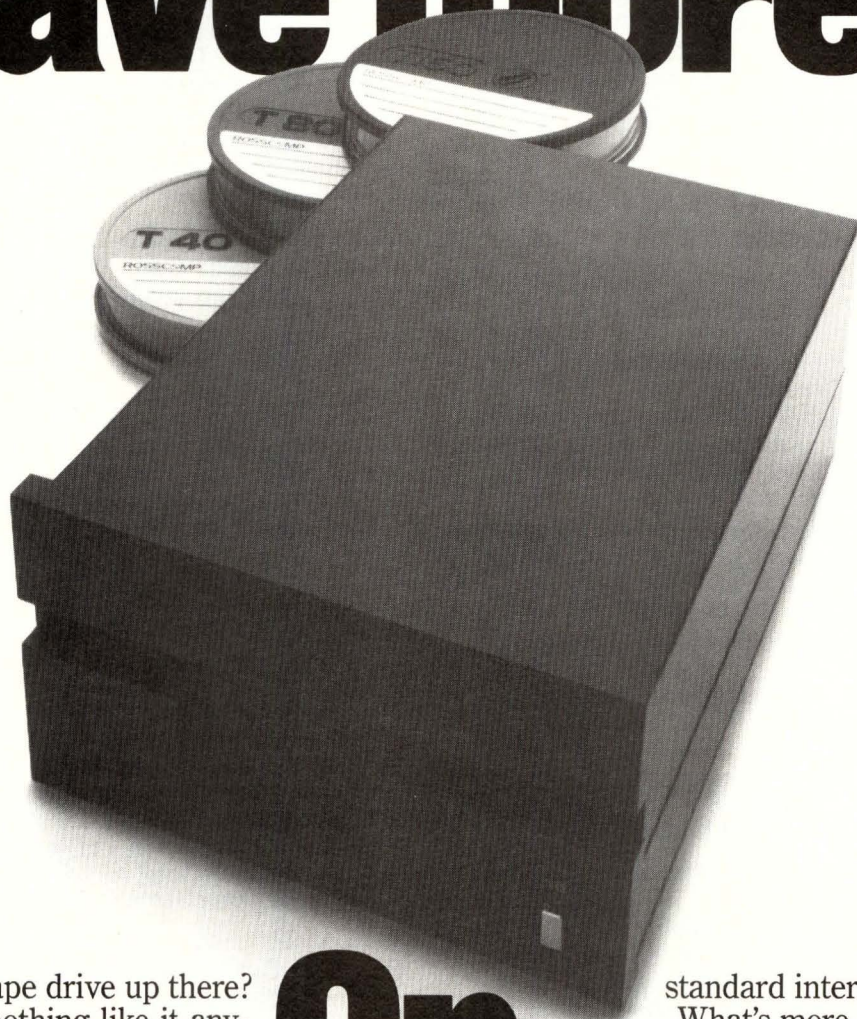

See that tape drive up there? Well, there's nothing like it anywhere else in the industry.

It's the Rosscomp 5 1/4" drive. Featuring upward expansion with 40, 80, or 160 megabytes. The proven reliability of standard 1/2" tape. Guaranteed data interchangeability. A 20 minute dump time. And industry-

On a little back up.

standard interfaces.

What's more, Rosscomp drives feature the lowest cost per megabyte you can find. Anywhere.

So give us a call at Rosscomp. And find out more about a little back up.

Our 5 1/4" drive can show you how to think small. And save big while doing it.

ROSSCOMP

We're backing up your future.

16643 Valley View Avenue, Cerritos, CA. 90701 (213) 926-5533

CIRCLE 41

(continued from page 66)

Session 6: Keynote Address

Wed 2:15 to 2:45 pm, Continental

Chair: P.W.J. Verhofstadt, Fairchild Microprocess Div, Mountain View, Calif

"A Positive Program for World Cooperation"
G. Madland, Integrated Circuit Engineering Corp, Scottsdale, Ariz

Session 7: High Speed Analog Circuits

Wed 3:15 to 6 pm, Continental 1-4

Chair: H. J. Boll, AT&T Bell Laboratories, Murray Hill, NJ

7/1 "A GaAs Monolithic Voltage Controlled Oscillator"

B. N. Scott, M. Wurtele, and B. B. Cregger, Texas Instruments, Inc, Dallas, Tex

7/2 "Fine Line nMOS Transresistance Amplifiers"

A. A. Abidi and R. A. Kushner, AT&T Bell Laboratories, Murray Hill, NJ; and B. L. Kasper, AT&T Bell Laboratories, Holmdel, NJ

7/3 "Distributed Cascode Amplifier and Noise Figure Modeling of an Arbitrary Amplifier Configuration"

D. E. Dawson, M. L. Salib, and L. E. Dickens, Westinghouse Electric Co, Baltimore, Md

7/4 "Computer-Aided Design of Nonlinear Microwave ICs"

M. I. Sobhy and A. K. Jastrzebski, University of Kent, Kent, United Kingdom

Session 8: Data Processing Circuits

Wed 3:15 to 6 pm, Continental 5-6

Chair: E. Swartzlander, TRW Defense Systems Group, Redondo Beach, Calif

8/1 "A 45-ns, 16 x 16 CMOS Multiplier"

Y. Kaji, N. Sugiyama, S. Ohya, Y. Kitamura, and M. Kikuchi, NEC Corp, Kanagawa, Japan

8/2 "A 25/50-MHz, Dual-Mode Parallel Multiplier/Accumulator"

F. Welten and J. Lohstroh, Philips Research Laboratories, Eindhoven, The Netherlands; and A. Linssen, RTC, Caen, France

8/3 "A 16-ns, 2-K x 8-bit CMOS SRAM"

N. Okazaki, T. Komatsu, N. Hoshi, K. Tsuboi, and T. Shimada, Sony Corp, Kanagawa, Japan

8/4 "A Dual-Port RAM with Internal Contention Resolution for Asynchronous Operation"

F. E. Barber, G. A. Ingram, and M. S. Strauss, AT&T Bell Laboratories, Allentown, Pa

Session 9: Dedicated Signal Processors

Wed 3:15 to 6 pm, Imperial

Chair: R. W. Brodersen, University of California, Berkeley

9/1 "A CCD Matrix-Matrix Product Parallel Processor"

A. M. Chiang, R. W. Mountain, D. J. Silversmith, and B. J. Felton, MIT Lincoln Laboratory, Lexington, Mass

9/2 "A Single-Chip, 20-Channel Speech Spectrum Analyzer"

Y. Kuraishi, K. Nakayama, and K. Miyadera, NEC Corp, Kawasaki, Japan

9/3 "An Integrated Phoneme Speech Synthesizer"

D. G. Maeding, C. C. Austin, P. J. Maimone, Silicon Systems, Inc, Tustin, Calif

9/4 "A Monolithic Programmable Speech Synthesizer with Voice Recognition"

T. Takamizawa, T. Yoshino, S. Abiko, M. Hashizume, K. Katoh, K. Chin, and A. Henderson, Texas Instruments Japan Ltd, Tokyo, Japan

Panel 1: Wafer Scale Integration

Wed 8 pm, Continental 1-4

Moderator: H. G. Gragon, Texas Instruments, Inc, Dallas, Tex

Panelists: D. Fussel, University of Texas, Austin;

E. Harari, Wafer Scale Integration, Inc, Santa Clara, Calif; R. Headrick, Hewlett-Packard, Cupertino, Calif; D. L. Peltzer, Trilogy Systems Corp, Cupertino, Calif; J. Raffel, MIT Lincoln Laboratory, Lexington, Mass; and R. R. Johnson, Mosaic Systems, Troy, Mich

Panel 2: Testing Methodology for VLSI

Wed 8 pm, Continental 5

Moderator: R. W. Dutton, Stanford University, Stanford, Calif

Panelists: J. Beyers, Hewlett-Packard, Fort Collins, Colo; P. Bottorff, IBM Corp, Endicott, NY;

E. McCluskey, Stanford University, Stanford, Calif; M. Nagamine, Fujitsu, Ltd, Kawasaki, Japan; R. Young, Intel Corp, Aloha, Ore; and J. Zasio, STC Research Corp, Santa Clara, Calif

Panel 3: System Requirements for GaAs Digital ICs

Wed 8 pm, Continental 6

Moderator: P. T. Greiling, Hughes Research Laboratories, Malibu, Calif

Panelists: R. Buchanan, RADC, Hanscom Air Force Base, Bedford, Mass; N. T. Linh, Thomson-CSF, Cedex, France; S. E. Nelson, Cray Research, Inc, Chippewa Falls, Wis; K. J. Sleger, Naval Research Laboratory, Washington, DC; and K. Suyama, Fujitsu, Ltd, Kawasaki, Japan

Panel 4: High Speed A-D Conversion

Wed 8 pm, Continental 7-9

Moderator: R. J. van de Plassche, Philips Research Laboratories, Sunnyvale, Calif

Panelists: A. Dingwall, RCA Solid-State Technology Center, Somerville, NJ; K. de Graaf, TRW Systems Group, Redondo Beach, Calif; T. van Kessel, Philips Research Laboratories, Eindhoven, The Netherlands;

T. Matsushita, Sony Corp, Kanagawa, Japan; G. L. Schaffer, Telmos, Inc, Sunnyvale, Calif; and S. S. Taylor, Tektronix, Inc, Beaverton, Ore

(continued on page 70)

Put powerful instrument control at your fingertips.

IEEE-488

The new Fluke 1722A Instrument Controller combines the computational ability and interfacing flexibility you need with the rugged packaging and easy-to-use human interface your factory demands. All at a new, low price. Now you can integrate your next factory test, process control or OEM system faster and put your people to work sooner.

The power of the 1722A is a 16-

bit single-board computer with 136K bytes of main memory. Its 12 MHz speed puts it in the same class as many minicomputers. Four programming languages are available to simplify programming, including Interpreted and Compiled BASIC, FORTRAN and Assembly. Each includes special adaptations for controlling IEEE-488-compatible programmable instrumentation. And if you

already own a 1720A Instrument Controller, you can run existing software on the 1722A—without modification.

The modular mainframe easily mounts in a standard 19 inch rack and allows you to configure the interfaces and memory to your exact needs. The IEEE-488 (1980) and RS-232-C interfaces can be expanded with an optional IEEE-488 and RS-232-C interface card, parallel interface card or dual serial interface card. Onboard memory is expandable to 2.6M bytes with RAM cards or 1.4M bytes with bubble memory.

The 1722A's touch-sensitive display dramatically simplifies system operation. Once programmed, your system can be operated entirely from the CRT. The 1722A displays only the pertinent options, allowing you to structure the user's response to a system. This helps reduce mistakes and increase throughput.

The 1722A is priced at \$7450 (U.S. list), including BASIC Interpreter, documentation and a limited one-year factory warranty. So get in touch with your local Fluke Sales Engineer or Representative. Or call us toll free at 800-426-0361 for more information.

IN THE U.S. AND NON-EUROPEAN COUNTRIES: **John Fluke Mfg. Co., Inc.**
P.O. Box C9090, M/S 250C
Everett, WA 98206
(206) 356-5400, Tlx: 152662

IN EUROPE: **Fluke (Holland) B.V.**
P.O. Box 5053, 5004 EB
Tilburg, The Netherlands
(013) 673973, Tlx: 52237

FLUKE®



Use the new graphics capability of our 16-line, 80-character touch-sensitive display to create more effective operator prompts.

Copyright © 1983, John Fluke Mfg. Co., Inc.
All rights reserved.

Ad No. 4817-1722

CIRCLE 42

(continued from page 68)

Panel 5: 1-Mbit DRAM Alternatives

Wed 8 pm, Imperial

Moderator: H. C. Kirsch, AT&T Bell Laboratories, Allentown, Pa

Panelists: S. Chou, Intel Corp, Aloha, Ore; M. Czekalski, Digital Equipment Corp, Maynard, Mass; C. J. Grohowski, IBM, Essex Junction, Vt; K. Miyasaka, Fujitsu, Ltd, Kawasaki, Japan; K. Itoh, Hitachi Central Research Laboratory, Tokyo, Japan; H. Penzel, Siemens AG, Munich, Germany; D. Segers, Mostek, Carrollton, Tex

Session 10: Nonvolatile Memories

Thurs 9 am to 12:15 pm, Continental 1-4

Chair: P. J. Salsbury, Seeq Technology, Inc, San Jose, Calif

- 10/1 "512-Kbit EPROMs"
D. Rinerson, M. Ahrens, M. Briner, J. Lien, B. Venkatesh, T. Lin, P. Song, S. Longcor, L. Shen, and D. Rogers, Advanced Micro Devices, Sunnyvale, Calif
- 10/2 "A 256-Kbit CMOS EPROM"
W. Ip, T-L. Chiu, T-C. Wu, and G. Perlegos, Seeq Technology, Inc, San Jose, Calif
- 10/3 "A 1-Mbit EPROM"
K. Okumura, S. Oya, M. Yamamoto, T. Watanabe, Y. Shimamura, and M. Kikuchi, NEC Corp, Sagamihara, Japan
- 10/4 "A 64-Kbit CMOS EEROM"
S. Mehrotra, T-C. Wu, T-L. Chiu, and G. Perlegos, Seeq Technology, Inc, San Jose, Calif
- 10/5 "A 55-ns CMOS EEPROM"
R. Zeman, C. Ho, and T. Chang, Exel Microelectronics, Inc, San Jose, Calif
- 10/6 "An 80-ns 1-Mbit ROM"
F. Masuoka, S. Ariizumi, T. Iwase, M. Ono, and N. Endo, Toshiba Corp, Kawasaki, Japan

Session 11: Scaling and Performance Aspects of Technology

Thurs 9 am to 12:15 pm, Continental 5

Chair: P. Cottrell, IBM General Technology Div, Essex Junction, Vt

- 11/1 "Integrated 84-ps ECL with I²L"
T. Nakamura, K. Nakazato, T. Miyazaki, T. Okabe, and M. Nagata, Hitachi Central Research Laboratory, Tokyo, Japan
- 11/2 "Merged Current Mode Logic"
P. J. Zdebel and W. L. Engl, Institut fur Theoretische Elektrotechnik, Aachen, Germany
- 11/3 "A 1.5- μ m Scaled CMOS Technology Chip"
S. S. Liu, G. E. Atwood, E. Y. So, B. Wu, R. Leftwich, K. Hasserjian, and B. Jones, Intel Corp, Santa Clara, Calif
- 11/4 "Performance Limits of NMOS and CMOS"
J. R. Pfiester, J. D. Shott, and J. D. Meindl, Stanford University, Stanford, Calif

- 11/5 "Physical Limits of VLSI DRAMS"
L. L. Lewyn and J. D. Meindl, Stanford University, Stanford, Calif
- 11/6 "Stability and Soft Error Rate Analysis of SRAM Cells"
B. Chappell, S. Schuster, and G. Sai-Halasz, IBM Research Center, Yorktown Heights, NY

Session 12: Microprocessors and Microcontrollers

Thurs 9 am to 12:15 pm, Continental 6-9

Chair: D. Seccombe, Hewlett-Packard, Fort Collins, Colo

- 12/1 "A 32-bit NMOS Microprocessor with a Large Register File"
R. W. Sherburne, Jr, M. G. H. Katevenis, D. A. Patterson, and C. H. Sequin, University of California, Berkeley
- 12/2 "A 5-V-Only Single-Chip Microcomputer with Nonvolatile SRAM"
P. Rosini, R. Finaurini, and M. Gaibotti, SGS-ATES, Milan, Italy
- 12/3 "A VLSI Communication Processor Designed for Testability"
S. Sacarisen, M. Stambaugh, P. Lou, A. Khosrovi, and R. Chang, Texas Instruments, Inc, Houston, Tex
- 12/4 "A VLSI Superminicomputer CPU"
W. N. Johnson, Digital Equipment Corp, Hudson, Mass
- 12/5 "A 32-bit Bus Interface Chip"
R. Schumann and W. Parker, Digital Equipment Corp, Hudson, Mass
- 12/6 "A 32-bit Microprocessor with Onchip Virtual Memory Management"
J. Beck, D. Dobberpuhl, M. J. Doherty, E. Dorenkamp, R. Grondalski, D. Grondalski, K. Henry, M. Miller, R. Supnik, S. Thierauf, and R. Witek, Digital Equipment Corp, Hudson, Mass

Session 13: Modems

Thurs 9 am to 12:15 pm, Imperial

Chair: M. S. Foster, Mitel Corp, Kanata, Canada

- 13/1 "A CMOS Ethernet Serial Interface Chip"
H-M. Haung, D. Banatao, G. Perlegos, T-C. Wu, T-L. Chiu, Seeq Technology, Inc, San Jose, Calif
- 13/2 "Signaling Pickoff Filter for FDM"
K. Fukahori and T. Glad, Silicon Systems, Inc, Nevada City, Calif; and L. Engh, Farinon Div/Harris Corp, San Carlos, Calif
- 13/3 "A 300-baud FSK Modem"
A. Takla and Y. A. Haque, American Microsystems, Inc, Santa Clara, Calif
- 13/4 "An Asynchronous FSK Modem"
K. Yamamoto, S. Fujii, and K. Matsuoka, Oki Electric Industry Co, Inc, Tokyo, Japan
- 13/5 "A 1200-baud FSK CMOS Modem"
C. A. Laber and P. Lemaitre, National Semiconductor Corp, Santa Clara, Calif

(continued on page 72)

In a world where what is promised is seldom delivered, we have earned a reputation for dependability. Whenever industry needs better ideas in flexible media, Verbatim responds.

We were the first to develop and manufacture in volume the 5 Mbyte, 8" disk. The first high-volume producer of the 5¼" minidisk, as well as the 96 tpi minidisk. And the first U.S. company to produce the new 3½" microdisk.

But then, leadership comes naturally to Verbatim. Having manufactured over

200,000,000 disks of all sizes and densities, we're the world's leading producer. In fact, one out of every four disks sold is made by Verbatim.

We maintain complete manufacturing facilities around the world as well as across the United States. Each plant is staffed with its own highly-trained service organization, ready to solve any customer problem.

Our commitment also shows in our continuing series of technology seminars. Purely non-commercial, these educa-

tional conferences are designed to keep engineers informed of the latest developments in flexible media.

It's all part of the Verbatim response. Advanced technology. Quality media. Reliable service.

So if it's flexible media you need, give us a call. We'll respond to your instructions, verbatim.

Verbatim®

323 Soquel Way, Sunnyvale, CA 94086
(408) 245-4400

Nothing's better than a Verbatim response.

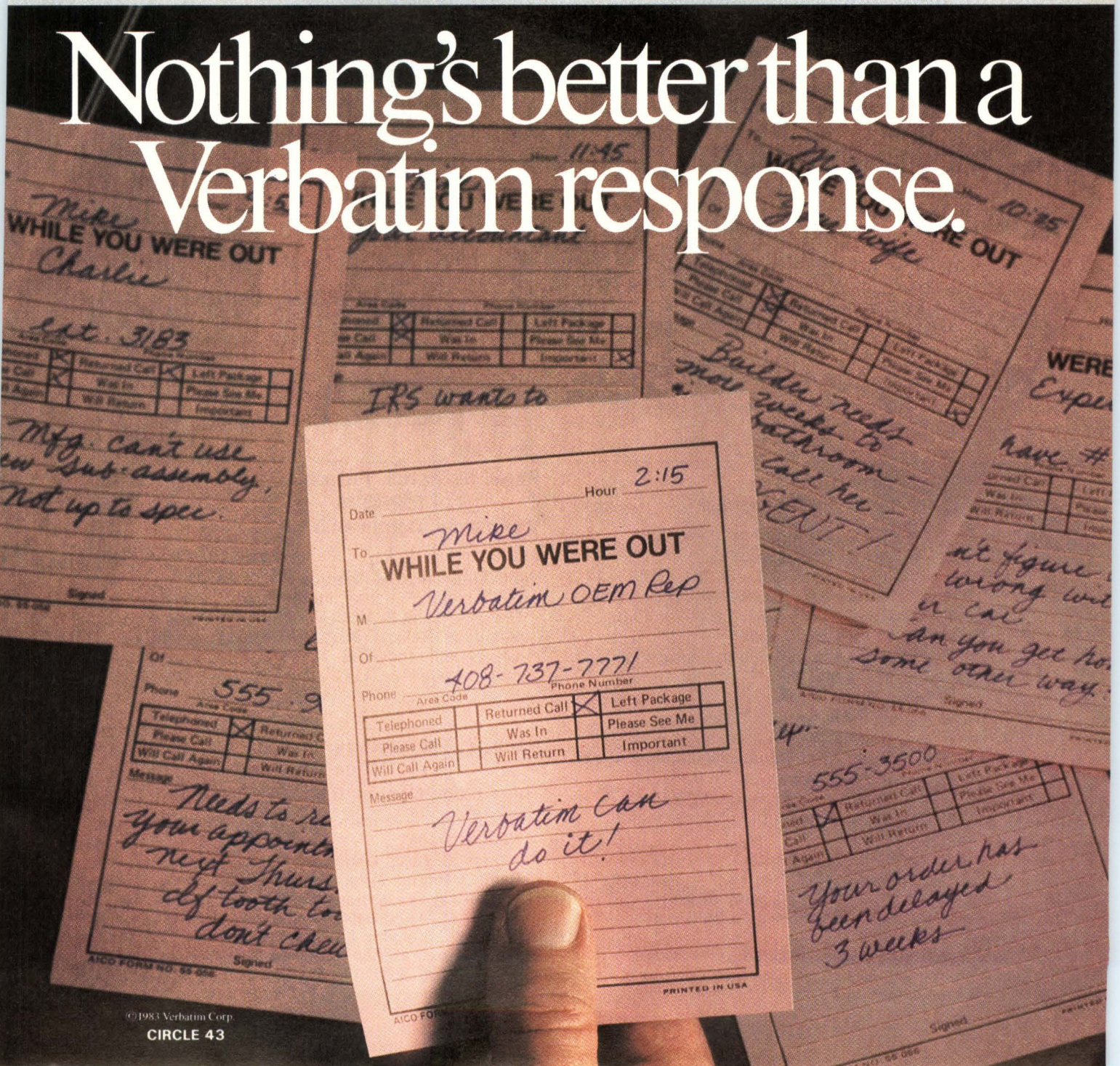

(continued from page 70)

- 13/6 "A 1200-bit/s QPSK Full-Duplex Modem"
E. Hanson, W. Severin, D. Richardson, E. Klinkovsky,
and J. Hochschild, Texas Instruments, Inc, Houston,
Tex; and J. Bingham, Racal-Vadic, Milpitas, Calif

Session 14: Signal Processing**Thurs 1:30 to 5 pm, Continental 1-4**

Chair: R. Baertsch, General Electric Corporate R & D,
Schenectady, NY

- 14/1 "A CCD TV Signal Processor"
S-i. Imai, T. Sakaue, and H. Moriyama, Toshiba
Corp, Kawasaki, Japan
- 14/2 "An Integrated CMOS-CCD TV Ghost Canceler"
S. Matsumoto, K. Kondo, T. Murata, S. Matsuura,
and M. Kazumi, Hitachi Research, Yokohama, Japan;
and I. Kobayashi and N. Horino, Hitachi Musashi
Works, Tokyo, Japan
- 14/3 "Facsimile Shading Corrector"
M. Togashi, S. Sato, and S. Ohsima, Matsushita
Graphic Communications Systems, Inc, Tokyo,
Japan; and K. Aruga and T. Nakamura, Matsushita
Electronics Corp, Kawasaki, Japan
- 14/4 "A 40-MHz, 308-Kbit CCD Video Memory"
H. J. M. Veendrick, L. C. Pfennings,
M. J. J. C. Annegarn, H. A. Harwig,
M. J. M. Pelgrom, H. J. F. Peuscher, J. G. Raven,
A. Slob, and J. W. Slotboom, Philips Research
Laboratories, Eindhoven, The Netherlands
- 14/5 "A VLSI Image Pipeline Processor"
T. Nukiyama, T. Kusano, K. Matsumoto,
H. Kurokawa, T. Hoshi, H. Goto, T. Temma, NEC
Corp, Kawasaki, Japan
- 14/6 "A Digital Radio Control Link for Implantable
Biotelemetry Applications"
S. J. Gross and J. D. Meindl, Stanford University,
Stanford, Calif

Session 15: Static RAM**Thurs 1:30 to 5 pm, Continental 5-9**

Chair: R. Pashley, Intel Corp, Santa Clara, Calif

- 15/1 "A 46-ns, 256-Kbit CMOS SRAM"
M. Isobe, J. Matsunaga, T. Sakurai, T. Ohtani,
K. Sawada, H. Nozawa, T. Iizuka, and S. Kohyama,
Toshiba Corp, Kawasaki, Japan
- 15/2 "A 30-ns, 64-Kbit CMOS SRAM"
K. Hardee, M. Griffuss, and R. Galvas, Inmos Corp,
Colorado Springs, Colo
- 15/3 "A 25-ns, 64-Kbit SRAM"
H. Ito, S. Koshimaru, O. Kudo, T. Ozawa,
T. Yamanaka, N. Yasuoka, H. Asai, N. Harashima,
and S. Kikuchi, NEC Corp, Kanagawa, Japan
- 15/4 "A 35-ns, 64-Kbit CMOS SRAM"
A. Au, N-H. Tsai, P. Chen, M. Hsue, M. Barry,
T. Reifsteck, and M. Osman, Fairchild Research
Center, Palo Alto, Calif
- 15/5 "A 20-ns, 64-Kbit CMOS SRAM"
O. Minato, T. Masuhara, T. Sasaki, Y. Sakai, and
T. Hayashida, Hitachi, Ltd, Tokyo, Japan
- 15/6 "A 28-ns, 64-Kbit CMOS SRAM with Bipolar
Sense Amplifiers"
J. Miyamoto, S. Saitoh, T. Iizuka, H. Momose,
H. Shibata, and K. Kanzaki, Toshiba Corp,
Kawasaki, Japan

- 15/7 "A 20-ns, 64-Kbit NMOS RAM"
S. Schuster, B. Chappell, V. DiLorenzo, and
P. Britton, IBM Research Center, Yorktown
Heights, NY

Session 16: Telecommunication System ICs**Thurs 1:30 to 5 pm, Imperial**

Chair: J. M. Huggins, Silicon Systems, Inc, Nevada
City, Calif

- 16/1 "A Single-Chip, High-Voltage Shallow-Junction
BORSH T LSI"
T. Ohno, T. Sakurai, Y. Inabe, and T. Koinuma, NTT
Atsugi and Musashino Communication Laboratories,
Kanagawa and Tokyo, Japan
- 16/2 "A Programmable CMOS Dual-Channel
Line Circuit"
B. K. Ahuja and W. M. Baxter, Intel Corp, Chandler,
Ariz; and P. R. Gray, University of California,
Berkeley
- 16/3 "A 150-mW Subscriber Line Board Controller"
P. P. Guebels, F. Van Simaey, and M. C. Rahier,
Bell Telephone Manufacturing Co, Antwerp, Belgium
- 16/4 "A 200-Kbit/s Burst Mode Transceiver with
Two-Bridge Tap Equalizer"
A. Komori, M. Furukawa, T. Sato, and T. Komazaki,
Oki Electric Industry Co Ltd, Tokyo, Japan
- 16/5 "A Burst-Mode LSI Equalizer with Analog-Digital
Building Blocks"
Y. Hino, T. Chujo, N. Ueno, and K. Fujita, Fujitsu,
Ltd, Kawasaki, Japan
- 16/6 "A Regenerator Chip Set for High Speed Digital
Transmission"
D. G. Ross, R. M. Paski, and D. G. Ehrenberg, AT&T
Bell Laboratories, Holmdel, NJ; and W. H. Eckton, Jr
and S. F. Moyer, AT&T Bell Laboratories, Reading, Pa

**Panel 6: Status, Future, and Standardization
of EEPROMs****Thurs 8 pm, Continental 1-4**

Moderator: R. W. Pryor, Pitney Bowes, Norwalk, Conn

Panelists: T. Iizuka, Toshiba R & D Center, Kawasaki
City, Japan; F. Jones, Inmos Corp, Colorado
Springs, Colo; D. McCranie, Seeq Technology, Inc,
San Jose, Calif; J. Skupnjak, Intel Corp, Santa
Clara, Calif; and W. E. Tchou, Xicor Corp,
Milpitas, Calif

**Panel 7: Technology for Data Transport
in an Office Environment****Thurs 8 pm, Continental 5**

Moderator: H. E. Mussman, AT&T Bell Laboratories,
Naperville, Ind

Panelists: C. Bass, Ungermann-Bass, Inc, Santa Clara,
Calif; P. Beirne, Mitel Corp, Kanata, Canada;
M. Patrick, Texas Instruments, Inc, Houston, Tex;
R. Snyder, Wang Laboratories, Lowell, Mass;
L. Lerach, Siemens AG, Munich, Germany; T. Tsuda,
Fujitsu Laboratories, Ltd, Kawasaki, Japan; and
H. Wurzburg, Motorola Semiconductor, Austin, Tex

(continued on page 74)

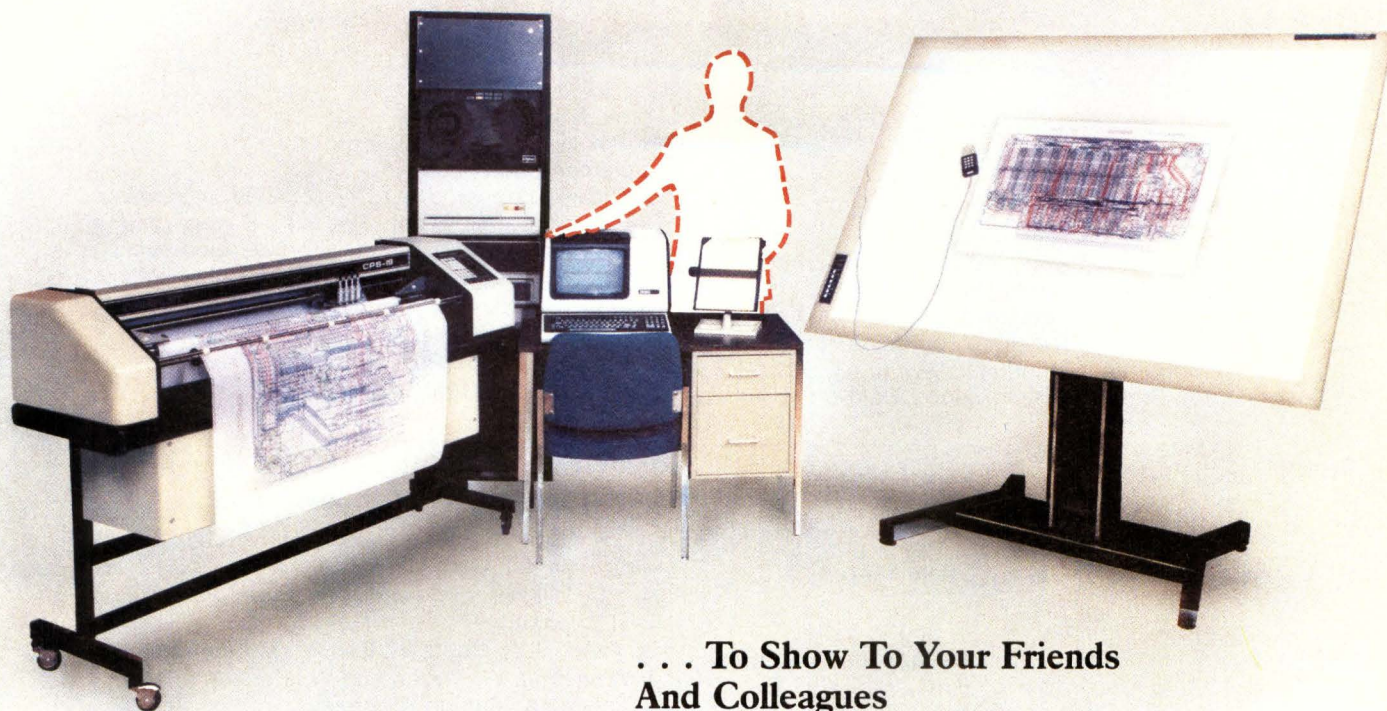

. . . To Show To Your Friends And Colleagues

It's worth 10,000 words in proving your capability to digitize, process and plot intricate and complex color graphics for computer-aided drafting, surveying, geophysical, circuit board, architectural . . . or any of a hundred other professional applications.

You input high-resolution graphics information through your Series 7000 Digitizer. Different size tablets are available, all the way up to "E." All feature 0.001" resolution, and are translucent so source material, even X-rays, can be accurately traced. All are capable of either single-point or data-stream output (of up to 160 coordinate pairs per second) for real-time freehand digitizing.

Your micro-, mini- or mainframe sends data to be unerringly plotted on the 4-color CPS-19 plotter. With solid resolution and accuracy of 0.001", and pen speeds of up to 15 ips, the CPS-19 produces rich and precise graphics exceeding "E" dimensions. Rugged and quiet servo drives complete this picture of a quality instrument, and provide you with color graphics of vivid excellence.

For the name, address and phone number of your nearest representative, write Houston Instrument, P.O. Box 15720, Austin, TX 78761. Phone 512-835-0900, or 800-531-5205 if outside Texas. In Europe contact Bausch & Lomb Belgium NV, Rochesterlaan 6, 8240 Gistel, Belgium. Tel 059-27-74-45, tlx 846-81399.

**A Family Of Instruments,
Made In The USA To Meet Your Needs.**

houston instrument

CIRCLE 44

You Belong in this Family Photo.

(continued from page 72)

Panel 8: High Speed Analog ICs

Thurs 8 pm, Continental 6

Moderator: R. van Tuyl, Hewlett-Packard, Santa Rosa, Calif

Panelists: J. Addis, Tektronix, Inc, Beaverton, Ore; D. Fraser, Bell Laboratories, Murray Hill, NJ; D. Hornbuckle, Hewlett-Packard, Santa Rosa, Calif; N. Kitagawa, Nippon Electric Corp, Kanagawa, Japan; M. Morishita, Mitsubishi Electric, Hyogo, Japan; and A. Podell, Podell Assocs, Palo Alto, Calif

Panel 9: Semicustom Analog LSI Design Trends and Directions

Thurs 8 pm, Continental 7-9

Moderator: A. R. Grebene, Micro-Linear Corp, Saratoga, Calif

Panelists: D. Bray, Interdesign, Inc, Scotts Valley, Calif; G. Kelson, Silicon Systems, Inc, Tustin, Calif; G. McGlinchey, Analog Devices, Inc, Palo Alto, Calif; P. Nance, Telmos Corp, Sunnyvale, Calif; E. Swanson, AT&T Bell Laboratories, Reading, Pa; and H. Yamada, Toshiba R & D Center, Kawasaki, Japan

Panel 10: Ultrahigh Speed Static RAMs

Thurs 8 pm, Imperial

Moderator: W. H. Herndon, Fairchild Advanced Research Center, Palo Alto, Calif

Panelists: R. Eden, Gigabit, Newbury Park, Calif; F. R. Janisch, Sperry, Roseville, Minn; H. Mayumi, NEC Corp, Kawasaki City, Japan; K. O'Connor, AT&T Bell Laboratories, Allentown, Pa; S. L. Smith, Intel Corp, Santa Clara, Calif; S. K. Wiedmann, IBM Laboratories, Boeblingen, Germany; and N. Yokoyama, Fujitsu Laboratories, Atsugi, Japan

Session 17: Semicustom Arrays

Fri 9 am to 12:15 pm, Continental 1-4

Chair: H. Borkan, U.S. Army Electronics Technology and Devices Laboratory, Fort Monmouth, NJ

- 17/1 "A CMOS 12-K Gate Array with Flexible 10-Kbit Memory"
M. Takechi, K. Ikuzaki, T. Itoh, M. Fujita, M. Asano, A. Masaki, and T. Matsunaga, Hitachi, Ltd, Tokyo, Japan
- 17/2 "A Subnanosecond 8-K Gate CMOS/SOS Gate Array"
S. Tanaka, K. Nakata, J. Iwamura, J. Ohno, and K. Maeguchi, Toshiba Corp, Kawasaki, Japan
- 17/3 "A 2- μ m Poly-Gate CMOS Analog-Digital Array"
J. B. Kuo, O-H. Kwan, D. C. Galbraith, F-C. Shone, J. D. Shott, J. T. Walker, R. W. Dutton, and J. D. Meindl, Stanford University, Stanford, Calif
- 17/4 "An ECL Field Programmable Logic Array"
C. Schmitz and H. Hingarh, Fairchild Research Center, Palo Alto, Calif; and M. Brown, H. Kwan, and J. Vithayathil, Fairchild Advanced Bipolar Div, Mountain View, Calif

- 17/5 "A VLSI Delay Commutator for FFT Implementation"
E. E. Swartzlander, Jr and W. K. W. Young, TRW Defense Systems Group, Redondo Beach, Calif; and S. J. Joseph, AT&T Bell Laboratories, Allentown, Pa
- 17/6 "An EEPROM for Microprocessors and Custom Logic"
R. Cuppens, C. D. Hartgring, J. F. Verwey, and H. L. Peek, Philips Research Laboratories, Eindhoven, The Netherlands

Session 18: 256-Kbit DRAM and Beyond

Fri 9 am to 12:15 pm, Continental 5-9

Chair: K. Hoffmann, Bundeswehr University/Siemens Corp, Munich, Germany

- 18/1 "A 256-Kbit DRAM with Descrambled Redundancy Test Capability"
D. Kantz, J. R. Goetz, R. Bender, M. Baehring, J. Wawersig, W. Meyer, and W. Mueller, Siemens AG, Munich, Germany
- 18/2 "A 256-Kbit DRAM"
E. Baier, H. Barsuhn, R. Clemen, and W. Haug, IBM Deutschland, Boeblingen, Germany
- 18/3 "A 288-Kbit CMOS Pseudo SRAM"
K. Kawamoto, Y. Yamaguchi, S. Shimizu, K. Oishi, N. Taninura, and T. Yasui, Hitachi Ltd, Tokyo, Japan
- 18/4 "A Sub 100-ns 256-Kbit DRAM in CMOS III Technology"
R. Kung, A. Mohsen, J. Shutz, P. Madland, C. Webb, E. Hamdy, C. Simonsen, R. Guo, K. Yu, and S. Chou, Intel Corp, Aloha, Ore
- 18/5 "Shared Word Line DRAM-Cell"
R. E. Scheuerlein, W. W. Walker, D. C. Morency, W. Noble, P. Bakeman, and D. Critchlow, IBM General Technology Div, Essex Junction, Vt
- 18/6 "An Experimental 1-Mbit DRAM with Onchip Voltage Limiter"
K. Itoh, R. Hori, J. Etoh, S. Asai, N. Hashimoto, K. Yagi, and H. Sunami, Hitachi Ltd, Tokyo, Japan

Session 19: General Purpose Analog Circuits

Fri 9 am to 12:15 pm, Imperial

Chair: E. A. Vittoz, Centre Electronique Horloger, Neuchatel, Switzerland

- 19/1 "An Analog Array Processor"
B. Gilbert, Analog Devices, Forest Grove, Ore
- 19/2 "A Monolithic p-Channel JFET Quad Operational Amplifier"
W. F. Davis and R. L. Vyne, Motorola Semiconductor, Tempe, Ariz
- 19/3 "A Power Bimos with Integral High Current pnp Transistor"
D. Cave, B. Bynum, and T. Houk, Motorola, Inc, Tempe, Ariz
- 19/4 "A Fahrenheit Temperature Sensor"
R. A. Pease, National Semiconductor Corp, Santa Clara, Calif

REAL TIME AT THE RIGHT PRICE: NOW YOU CAN RENT THE MC68000 EMULATION PACKAGE.

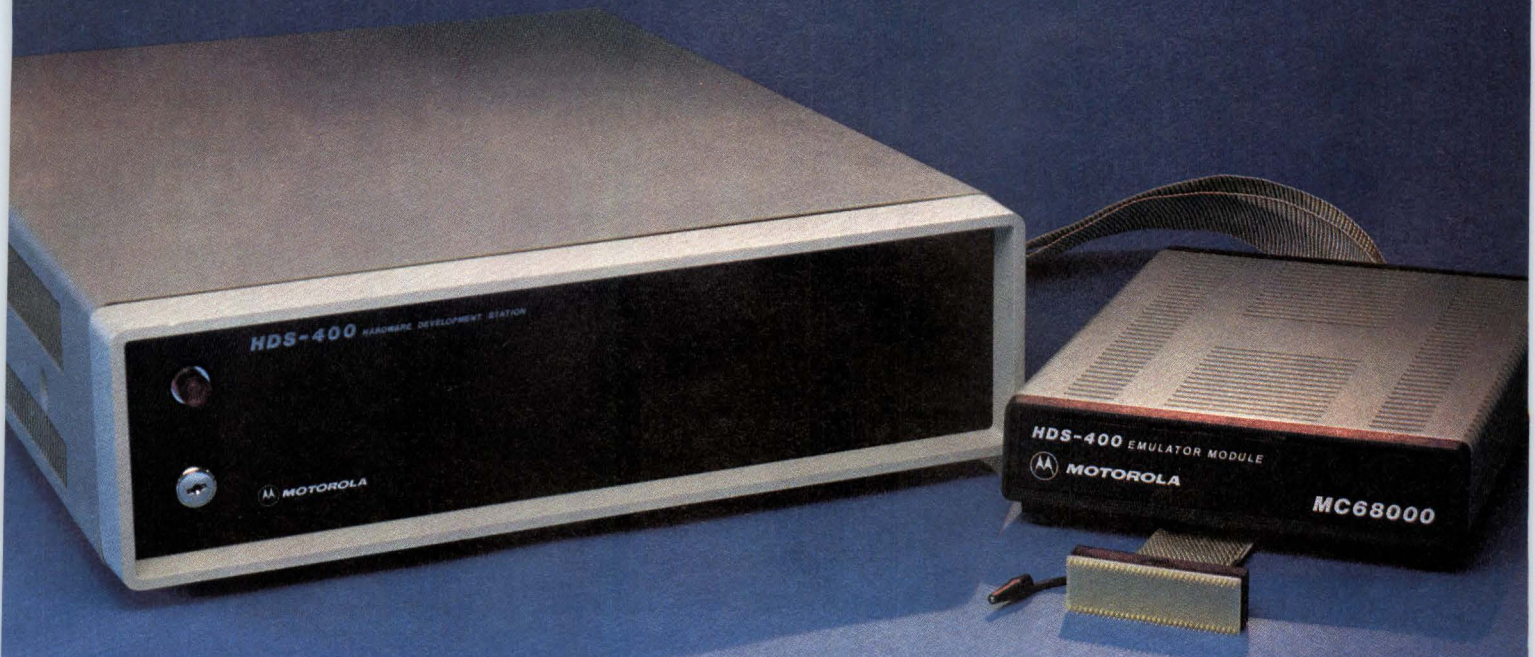

The HDS-400 is the most versatile emulation system available for Motorola's 68000 series microprocessor. And now you can rent this system from Leasametric, the foremost renter of quality electronic test equipment.

Speed, simplicity and power. The HDS-400 runs up to 12.5 MHz clock speed, the fastest today. And it performs real-time emulation and analysis at clock speeds up to 10 MHz with no wait states. So you can gauge your prototype's true performance.

This emulation system is unique. It can download both the target system code and the debugging system from either the Motorola EXORmacs™ Development System, DEC VAX™ or Motorola VME/10 as hosts. The HDS-400 can serve as a fully functional substitute for the MPU in your target system. And its analysis commands are straightforward, so you can rapidly debug and integrate your target system.

But this simplicity and power is further enhanced by the Bus State Analyzer module that is also available for rent from Leasametric. With it you can gather data by continuous trace mode, sequential trigger mode and window trigger mode. Plus generate performance histograms that provide a clear picture of system performance efficiency.

Rent the best from the best. Rent the HDS-400 from Leasametric and you get equipment that has been rigorously tested and fully calibrated. It arrives ready to work. Complete with operator's manual and all accessories.

Our service is famous in the industry. We'll ship your order immediately and be there if you need us. If a system problem occurs, we'll take immediate action. With timely on-line diagnostics, on-site service or replacement.

Call Leasametric and stretch your cash. Our rental charges are much smaller than the capital outlays of buying. Rent what you need. Or lease it. Or rent with option to buy. We'll tailor a package that fits your needs.

Rent and you pay for equipment that's being used, not sitting on a shelf somewhere. Real-time emulation at the right price. And Leasametric has thousands of other quality items for rent. We'd be pleased to tell you more—and to send our latest catalogue. Call us at **800-227-1817**. In Europe, call Leasametric GmbH, Eching/Munich. (089) 3192007.

Rent the best name in the business
from the best name in the business.

 **LEASAMETRIC**

CIRCLE 45

DON'T A DRIV A STR

We're the world's leading manufacturer of micro peripheral disk drives. Which means that, whenever

TAKE E FROM ANGER.

you need a reliable 5¼" floppy, 5¼" Winchester or 8" ThinLine™ floppy, we're the supplier you can rely on.

Tandon

THE MOST SUCCESSFUL DISK DRIVE COMPANIES YOU EVER HEARD OF.

Telex: 194794. Regional Sales Offices: Boston (617) 938-1916 • New York (201) 449-7720 • Atlanta (404) 934-0620 • Chicago (312) 530-7401
Frankfurt, West Germany 6107-2091, Telex 411547 • London, England (0734) 664-676 Telex: 848411. Distributors: Hall-Mark, Kierulff, Schweber.

CIRCLE 46

"Backup claims



Low
Cost
Small Size
High Capacity
Innovative

High Performance
Interchangeable
Operator Control
Star

were too confusing. Then I called Cipher™

Whether you need a ½" tape drive compatible with streaming or start/stop software, we have your solution with our Microstreamer® or CacheTape™.

Or whether you need a ¼" cartridge tape drive compatible with QIC or floppy disk standards, we have your solution with our 540 or FloppyTape™.

The next time you find backup confusing, call the leader. No matter what your system requirements are, we have the tape drive that meets your backup needs. Call or write us today for a free product brochure.

cipher®
data products, inc.

10225 Willow Creek Road, P.O. Box 85170
San Diego, California 92138
Telephone (619) 578-9100, TWX: 910-335-1251

European subsidiaries in:
United Kingdom (phone: 0276-682912),
West Germany (phone: 089-807001/02),
France (phone: 1-668-87-87)

CIRCLE 47

Performance
Reliability
Convenience
Standardization
Reliability

We can't keep it quiet any longer!

Occam is the language for today's microprocessors

Today's microprocessor systems are growing up. New boundaries in performance and functionality are being called for and met.

But software tools are falling behind. Assembler programming is woefully inadequate. Traditional high level languages — Pascal, C — leave critical portions of the systems to low level languages. And new languages like Ada are too complex for serious consideration.

Where can systems designers turn? Occam.

Occam is a new language created just for system design and implementation. With the ability to describe concurrency and message passing built right into the language at the lowest level, all aspects of a system can be designed and programmed in occam. From interrupt handling to signal processing to screen editors to artificial intelligence. And it's available for the iAPX86 and MC68000 families of microprocessors now.

With the Occam Programming System, INMOS provides the optimum environment for the creation of occam systems for these microprocessors. An intelligent

editor understands the language. Source-level debugging lets you investigate the behavior of your program in terms of the program you have written. There's even a word processor package. Together with the abilities of the language, these features will significantly reduce your development time and risks.

Even more, occam equips you for the future. As increased performance requirements move you into multiprocessor systems, your software is already written. Occam programs may be configured to run on one, many or even hundreds of connected processors. And you'll also be ready to

take advantage of the massive increase in performance that INMOS' transputers — a family of 16 and 32 bit VLSI devices integrating processor, memory and communications onto one chip — will offer.

We have a complete set of evaluation and development tools available for occam. Send today for informative literature pack which describes occam, the Occam Evaluation Kit, the Occam Programming System and the transputer.

For immediate response call us at (303) 630-4363, or write:

Occam, P.O.
Box 16000,
Colorado
Springs, CO
80935. We'll take

care of the rest.



and occam are trademarks of the Inmos Group of Companies

CIRCLE 48



EVALUATE DISK-DRIVE PERFORMANCE WITH MARGIN ANALYSIS

Most performance testing of disk drives is costly and time consuming, but margin analysis provides a fast, accurate appraisal of a drive's error rate.

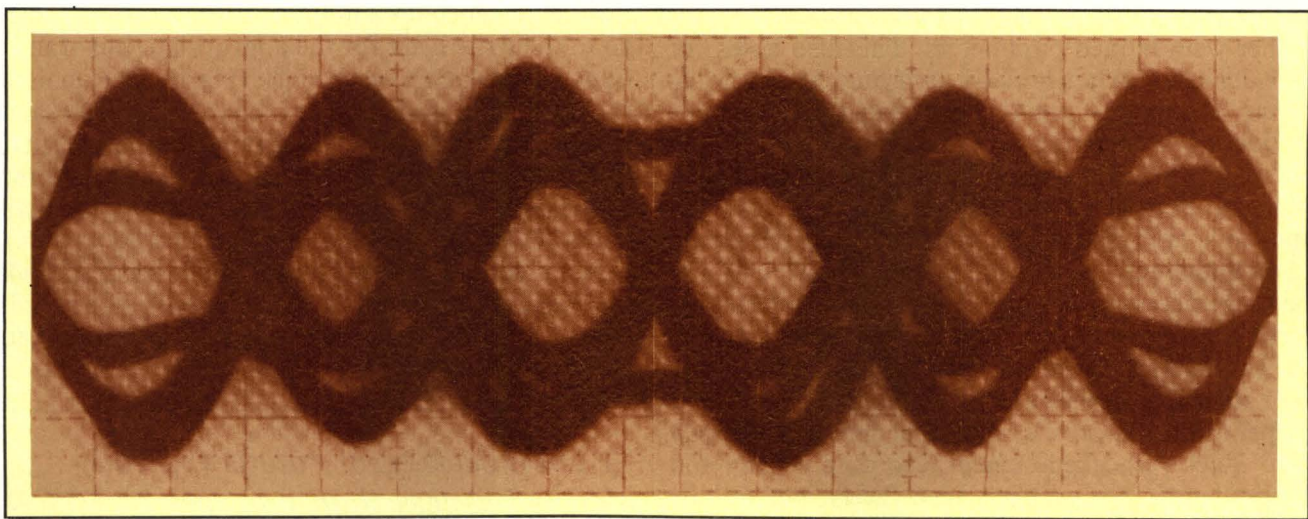

by Nigel D. Mackintosh

Disk drives offer one of the most popular and convenient means for storing large amounts of data. But problems can crop up if the recovered information fails to match what was originally put on the disk. Both users and manufacturers of disk drives realize that these machines will occasionally produce errors, and that a method is needed for evaluating the so-called soft-error rate of a drive. Indeed, error-checking methods are available. However, most are so time consuming that a user might be occupied for days or weeks before obtaining meaningful results.

To reduce the time required to check drive performance, the technique of margin analysis is used to examine the inner workings of the read/write circuitry. Margin analysis actually involves a

Nigel D. Mackintosh is director of storage technology at Century Data Systems, PO Box 3056, Anaheim, CA 92803. He holds a BS in computer science and a PhD in magnetic recording from the University of Manchester, England.

number of techniques, some of which permit data evaluation from the disk with just an oscilloscope. Another type of analysis requires the construction of a special decoder board, but this can be expensive and complex, depending on the number of drives to be tested and the frequency of testing. Although even simple margin analysis testing gives very useful information about disk drive operation, more elaborate tests can provide some of the most useful tools available to both drive designer and manufacturer.

A drive's performance is determined by testing it against its rated specifications. However, not every specification needs to be tested, and some characteristics are not relevant to margin analysis. Therefore, a starting point for margin analysis begins with knowing which drive parameters are important, and which can be safely neglected.

Key specifications for the Century Data Systems Advanced Marksman disk drive (AMS 315), a 315-Mbyte machine, are listed in the Table. The first item—capacity—should be checked initially. But once verified, it need not be rechecked in drives of the same type since it is fixed by many

AMS 315 Drive Specifications

Capacity (unformatted)	315.2 Mbytes
Data rate	1.209 Mbytes/s
Access time—track-to-track average	6 ms 25 ms
Latency (average)	8.3 ms
Rotational speed	3600 rpm
Lineal recording density	6050 bits/in.
Track density	712 tracks/in.
Number of cylinders	845
Recording method	MFM
Seek-error rate	1 in 10^6 seeks
Bit-error rate (soft)	1 in 10^{10} bits

other well-defined parameters. This also holds for the data rate. After initially verifying this specification, it is highly unlikely to change in the same model drive from the same vendor.

Access time is another story. It is highly dependent on both electrical and mechanical drive components, and should be checked for each drive. Track-to-track access time may be about 6 ms and average access time only 25 ms. The most lengthy tests are for average access time measurement, but to run 1000 of these still only takes 25 s.

Latency is a reasonably stable parameter that depends on the drive's rotational speed. It is easily and quickly checked. Lineal recording density and track density are on most spec sheets, but for the user, they are irrelevant as long as the error rates are acceptable. The number of cylinders is critical for proper mapping of information, but once checked and verified, it will not vary from drive to drive. Likewise, the recording method is not of significance to a user since most experts agree that the differences between the various codes are quite small.

A good seek-error rate is typically defined as less than one seek error in 10^6 seeks. To perform 10^6 random seeks can take several hours, and the test should be repeated several times to obtain a good average. However, experience shows that most causes of seek errors have catastrophic rather than continuous effects. Thus, a drive either fails the specification test miserably or exceeds it comfortably. In practice, therefore, a short test for this parameter is usually sufficient.

Finally, there is a bit-error rate—sometimes called raw or soft-error rate—typically specified as less than one error in 10^{10} bits. A quick calculation shows how long it can take to test for the parameter. Assume an average access time of 25 ms, and an average block of data to be 256 bytes. This gives an average transfer rate during random seeks of 256×8 bits every 25 ms, or a rate of 80 kbits/s. To

check for an error rate of 1 bit in 10^{10} , statistics mandate that the check should be for 10 times that many errors, and then averaged. In other words, the test should be for 10 errors in 10^{11} bits transferred. But to transfer 10^{11} bits takes $[10^{11}/80k]$ seconds, or approximately 10^6 seconds, which is 15 days.

Obviously, testing the bit-error rate puts a tremendous burden on manufacturers who must potentially check hundreds or thousands of units. Fortunately, there are various techniques for getting around the problem of fully testing the soft-error rate specification on a disk drive. But first, a designer must understand what occurs when there is an error in received data.

Recovering disk data

In a typical read/write circuit, incoming non-return to zero (NRZ) data and the write clock pass through an encoder and the write driver. They then go to the write head for the appropriate flux transitions to be written on the disk (Fig 1). During data recovery, flux transitions excite the read head and the resulting voltage passes through a preamplifier, filter, differentiator, and a zero crossover detector to form the data transitions. At this point, the data splits. One part goes into a phase lock loop (PLL), which creates a data window. This is used to clock the data transitions into a decoder to permit recovering NRZ data and to send it with a read clock to the controller.

A good seek-error rate is typically defined as less than one seek error in 10^6 seeks.

The typical waveforms of this operation are illustrated in Fig 2. Five data bits are defined, representing the pattern 00101. The top trace is the write current according to modified frequency modulation (MFM) rules. MFM is a very common recording code defined such that a logic 1 data bit causes a change in the write current in the center of the bit cell. Logic 0 data does not cause a change in the write current except when two 0s occur in succession. This produces a change in the write current (see the top waveform) causing a change in the direction of magnetization of the disk. Note that these changes in magnetization direction coincide with the peaks of the pulses in the readback voltage.

The objective is to detect these peaks since they define the original data. The best way to detect peaks is by differentiating the signal and finding where the value equals zero. Note that the zero value of the differentiated signal corresponds to the peak value of the data signal. Next, the differentiated wave is squared to allow the recovery of

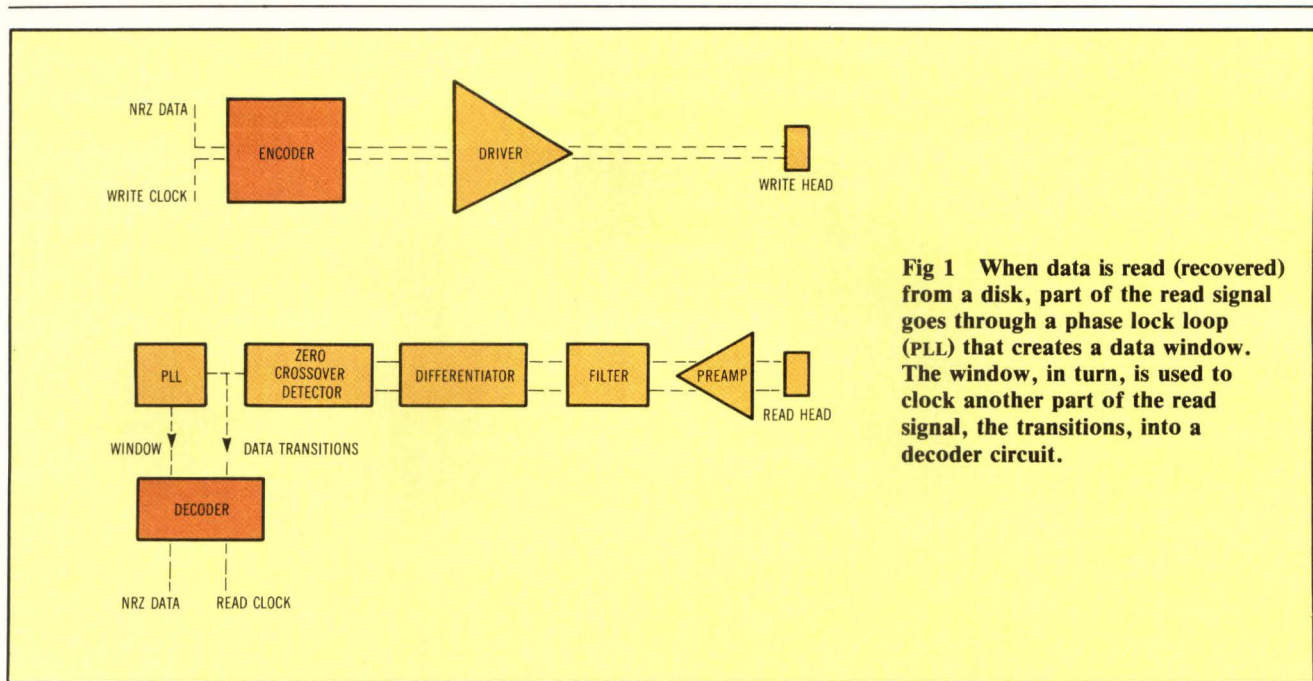

Fig 1 When data is read (recovered) from a disk, part of the read signal goes through a phase lock loop (PLL) that creates a data window. The window, in turn, is used to clock another part of the read signal, the transitions, into a decoder circuit.

the original write current. From this, one can deduce the original data pattern.

First, it must be determined whether the data transitions occur in the center of a bit cell or on the junction of two bit cells. This indicates whether the transition represents a logic 1 or a pair of logic 0s. The function of the PLL is to provide a signal that delineates the center of a bit cell from the edges. This waveform, called the data window, is shown at the bottom of Fig 2. The high portion in each cell is known as the "ones window" because if a transition occurs in the readback in this window, a logic 1 must have been recorded. It is common practice to look only for the logic 1s transitions since the absence of a 1 transition automatically means the bit was a logic 0.

Unfortunately, the real world is not as well defined as the waveshapes of Fig 2 indicate. In practice, recovered transitions are not perfectly located in the center or at the edges of the bit cells. This results from noise picked up from the disk and noise introduced by the preamplifier. Interference of the readback pulses also causes the waveform to distort and introduce so-called peak shift. Moreover, the PLL generates some timing jitter, and the delay through the read amplifier is not constant at all frequencies, causing additional distortion. Finally, interference results from previous data incompletely overwritten or from data on adjacent tracks of the disk.

Analyzing disk data

A distribution can be plotted to show the results of various types of noise introduced to data on a disk [Fig 3(a)]. The horizontal scale represents the data window of a drive with a 100-ns wide bit cell and using MFM code. The width of the data window is half that of the bit cell, or 50 ns. On the

vertical scale is the probability density of a given transition occurring at any point within the data window. According to this all ones pattern curve, the vast majority of transitions fall perfectly in the middle of the data window.

In fact, the curve is basically a Gaussian, or normal, distribution because Gaussian noise introduced by the disk and preamplifier is usually the dominant cause of timing errors. From the curve, it appears that there is little chance of a transition falling outside the data window. Theoretically then, there is little chance of misreading the data. The problem with the curve however, is that the error-rate specification is just one error in 10^{10} bits (a probability of 10^{-10}) and this is not easily seen on a linear scale.

A better representation of the data in Fig 3(a) is provided by using a curve with a logarithmic vertical scale as shown in Fig 3(b). The distribution of

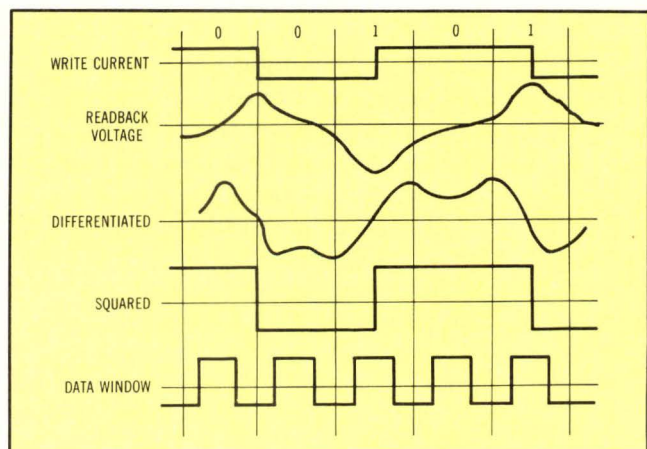

Fig 2 The read/write waveforms from the disk circuitry are shown here. Data window pulses serve to define the center of a bit cell. Data transitions must occur correctly in a bit cell, otherwise an error will be recorded.

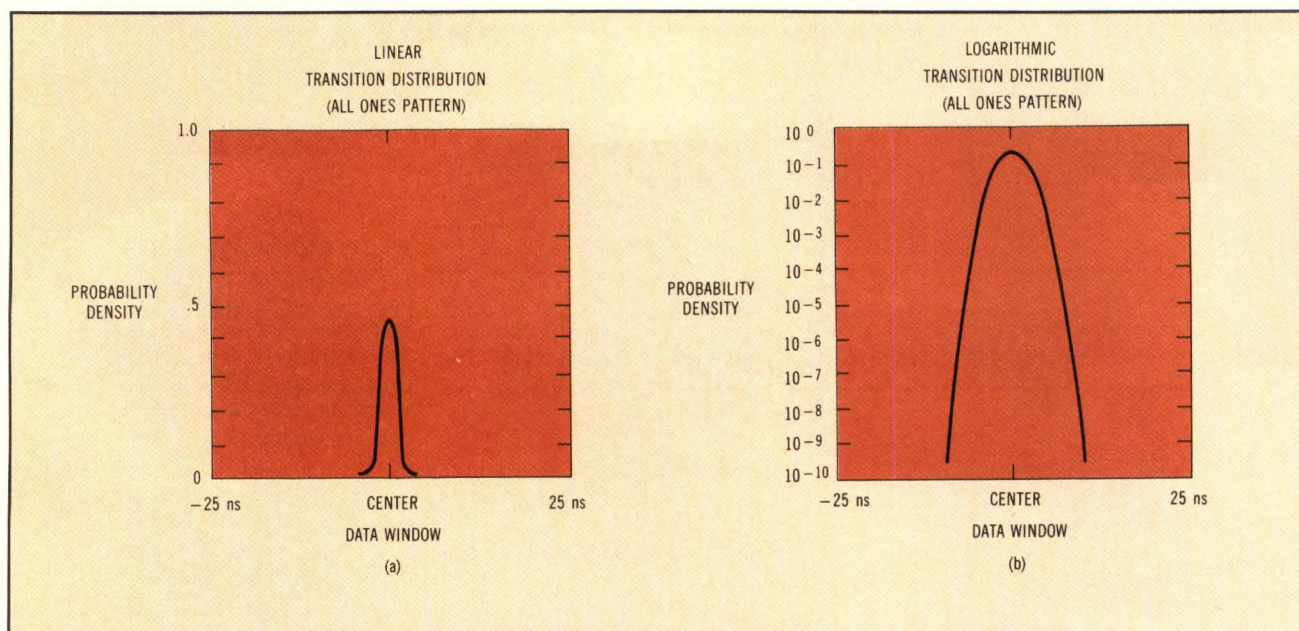

Fig 3 A linear transition distribution plot shows where in the bit cells recovered data falls. In plot (a), all recovered logic 1 data bits appear to fall very near the center of the 50-ns wide window. A more accurate determination of data distribution is provided by a logarithmic distribution plot (b). Only one transition in 10^{10} bits occurs as much as 10 ns away from the center of the data window.

both curves is the same, but Fig 3(b) shows more clearly that once in every 10^{10} bits, a transition will occur 10 ns away from the center of the window on each side. But this still leaves a 15-ns margin on each side before an error will occur.

A distribution for a "peak shift" pattern—an MFM 110110 repeating pattern—is graphed in Fig 4. Here, the two transitions in the pair oppose each other and push apart. This produces a fixed shift in the two peaks, one to the left and one to the right of center. The curve results from the transfer of a huge number of bits (approximately 10^{11}) and each one has been examined to determine exactly where in the data window it fell. The curve shows that many of the bits fell 7 ns to the left of center and equally as many fell 7 ns to the right. This represents the amount of peak shift introduced into the curve.

A normal Gaussian distribution around each of the two nominal peaks is graphed. In effect, it is a bimodal distribution that clearly shows the amount of peak shift, as well as the signal-to-noise ratio as shown by the slope of the curve.

Ideally, all recovered data transitions should fall in the middle of the data window, but this is not a practical, absolute necessity. That is, transitions can move around inside the window as long as they do not jump out, since that would cause an error. Transitions should stay away from the window edges, giving a greater degree of noise margin.

Using margin analysis techniques

Information derived from various types of distributions can be used to estimate the normal error rate without having to wait days or weeks for an

answer. The first and simplest margin analysis method is called the eye pattern.

In the eye pattern method, an oscilloscope is used to examine the differentiated readback signal. The scope is triggered from one zero crossing to permit examination of subsequent zero crossings as shown in Fig 5. Three different data patterns are superimposed here to show the effects of random data transfers. On a drive having good noise margins, transitions occur fairly accurately and consistently. The "eyes" or loops will therefore be very large. In the bad margin case, shown to the left of the Fig 5,

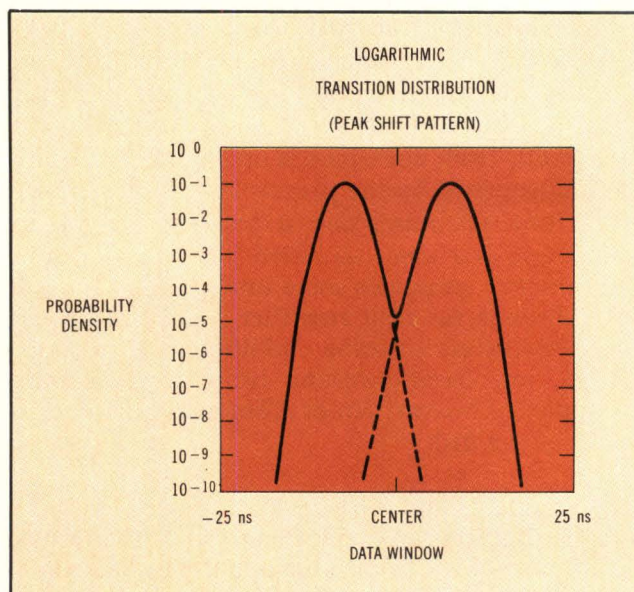

Fig 4 This logarithmic distribution plot results from distortion introduced on the read signal by components of the readback system.

THE JETSTREAM™ 16 IS HERE

In excess of 100 megabytes

QIC-02/QIC-24 compatible

SCSI/QIC-24 compatible

16 or 9 tracks

Streaming on 9 or 16 tracks, the new high-density JETSTREAM™ 16 is fast, dependable, and big in capacity. Winchester back-up, data interchange, or archival storage are ideal applications for this exciting machine that packs in excess of 100 megabytes on a single data cartridge and takes no more space than an 8-inch floppy. OEM drives, as well as JETSTREAM™ systems are available. Contact us today for full details at North Atlantic Qantex, 60 Plant Avenue, Hauppauge, NY 11788 (516) 582-6060 (800) 645-5292

 north atlantic
Qantex



JETSTREAM™ 16

succeeding zero crossings occur at different points in time. Thus the eyes appear small or almost closed. The advantage of the eye pattern is that it requires very simple equipment and is the fastest method for analyzing a drive's performance.

A second margin analysis technique, window sliding, can also be performed with an oscilloscope. Fig 6 shows the relationship between the data window and data transitions, as well as a typical distribution plot for a peak-shift pattern. The number of transitions that occurs at the edges of the window is virtually nil; that is, the probability of a transition falling on either edge of the data window is far less than 1 in 10^{10} . (If 10^{10} bits were transferred, not one would be expected to fall outside the data window.) But what happens if everything remains the same, and the data window is slid slightly to the right, as shown in Fig 6?

If the data window is moved 15 ns to the right, it is apparent that many transitions will fall outside the left-hand edge of the window. In fact, the probability from the plot is roughly 10^2 . For every 100 bits transferred, on average, one would fall outside the data window. Therefore, window sliding provides a method for artificially increasing the error rate of a disk drive.

Window sliding is used in the following manner. If the data window position is easily alterable on the drive (perhaps by a potentiometer), set the drive to transfer data continually and adjust the potentiometer to slide the window until a fairly large number of errors occurs (eg, about one error per second). Depending on the particular test used, it is possible to be on a track transferring data, or seeking between tracks and transferring data. This might represent an error of 1 in 10^6 or 10^7 . By measuring how far the window has been shifted with the scope's time base, the amount of margin for a particular error rate is determined.

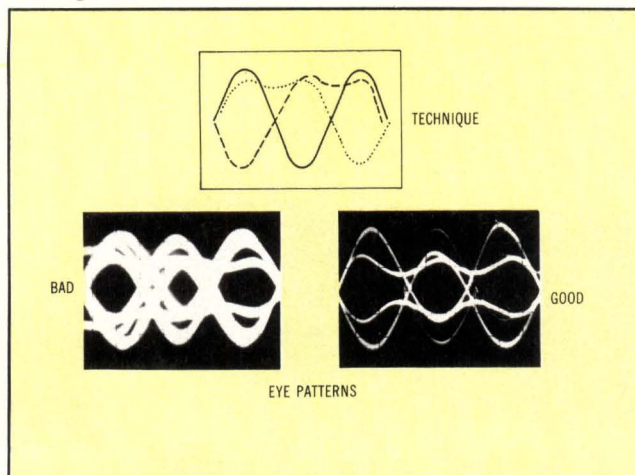

Fig 5 Eye pattern analysis is the simplest, fastest method for judging the error-rate performance of a disk drive. An "open eyes" pattern (on the right) indicates that data transitions occur at consistent points in time. Thus, the drive has adequate error margins.

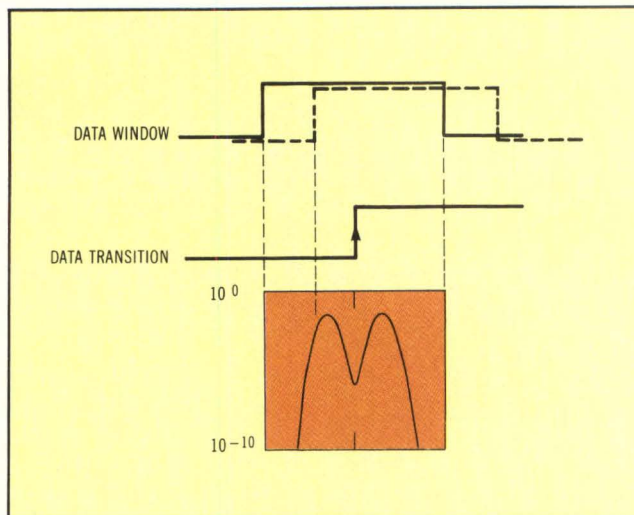

Fig 6 A window sliding technique provides a quantitative measure of a drive's error-rate performance. By moving the data window (sliding it in time), it is possible to determine the number of transitions that will fall outside the window. This technique is much more accurate than eye patterns since the error rate can be calculated numerically.

For example, assume that it is possible to slide the window 10 ns on the left-hand side at an error rate of 10^7 . By consulting the typical slope of the transition distribution curve, it can be extrapolated that at the 10^{10} error rate the drive has about an 8-ns noise margin. Sliding the window in the opposite direction produces a similar result for the other side.

Although window sliding is more sophisticated than eye patterns and gives a quantitative measure of the margins, it is not always possible to slide the window in a drive. Even if sliding is possible, it is difficult to know if the drive's operation is disturbed by such sliding. It is possible to interfere with the normal operation of the phase lock loop by artificially changing the relationship of data transitions in the window. This can invalidate the data.

Despite these drawbacks, window sliding is a useful technique. By moving the data window in increments, a transition distribution plot similar to the one in Fig 6 can be produced. However, better methods exist, and these are best performed with a dedicated decoder board.

It has been shown how the data window and data transition signals both feed into the decoder. If both signals can be brought offboard, a dedicated variable window decoder can be built specifically for margin analysis. Since this decoder board will be used to test all disk drives, it can be built as complex as is required to do the job.

The controller in charge of the testing ignores the read data and read clock sent from the drive's normal read channel. Instead, it takes these signals from the variable window decoder. The entire process can be automated in the controller so that it slides the window in increments and measures the error rate for each increment. This method ensures that all drives meet acceptable margins.

ONE STOP WINCHESTER DRIVE TESTING!

DTS-1000 Drive Test Station tests four drives at a time.

DUAL MICROPROCESSOR BASED ANALYZER/MUX INCREASES THROUGHPUT WITH THE FASTEST, MOST COMPLETE SOLUTION.

With up to four winchester drives on line, you can now perform the most advanced testing available and *save time*.

The new DTS-1000 provides complete testing of drive #1 with simultaneous interleaving seeks on drive #2, #3 and #4. Total testing time for all drives is cut by as much as 15%.

You get a detailed printout to accompany each drive. And error reports can be made to tell much more than just what's wrong.

If "early abort" is signaled, the buffered connection allows replacement of any drive without interrupting testing of the others.

The DTS-1000 has many advanced features including

the ability to perform complete read margin tests in 2 nano-second increments on each drive ...and individually programmable voltage margin tests that provide $\pm 10\%$ variation on the +5V and +12V levels. The DTS-1000 contains a Wilson Winchester Analyzer plus multiplexer panel and printer ports.

The Pros Use Wilson

Wilson is the 10-year world leader in test exercisers for disk and tape drives. Our customers include: Burroughs, Cado, Cipher Data, Computer Automation, Dataproducts, DEC, Fujitsu, Harris, IBM, Kaypro, Maxtor, Micropolis, Perkin Elmer, Pertec, Priam, Seagate, Sperry Univac, System Industries, Tandem, Tandon, TRW, Wang and others.

SEE THE WILSON LINEUP

MWX-1000 Winchester Analyzer
MFX-1000 Floppy Drive Analyzer
MPX-1000 Printer Terminal Analyzer
SX-530 Disk Memory Analyzer
HAT-500 Head Alignment Tester
TFX-500 Tape Formatter Testercizer
TX-500 Tape Testercizer
TX-1200 Tape Testercizer
FX-500 Floppy Disk Testercizer
DX-500 Cartridge Disk Testercizer
DX-1000 Cartridge Disk Testercizer
CX-500 Communications Testercizer

SEND FOR COMPLETE INFORMATION AND PRICES.

 **WILSON
Laboratories, Inc.**

2237 N. BATAVIA STREET • ORANGE, CALIFORNIA 92665
TELEPHONE (714) 998-1980 • TELEX 181 598

- Printer connected via RS-232-C port.
- Keys to set/measure drive parameters.
- Operation keys allow single-key selection of tests.
- Entry pad lets user enter custom programs.
- Easy-to-read 16-character alphanumeric display.
- Error and status indicators identify each mode.
- Command keys to control analyzer operation.
- Individual-drive test control switches/indicators.
- Drive and power cables connect up to four drives.

CIRCLE 50

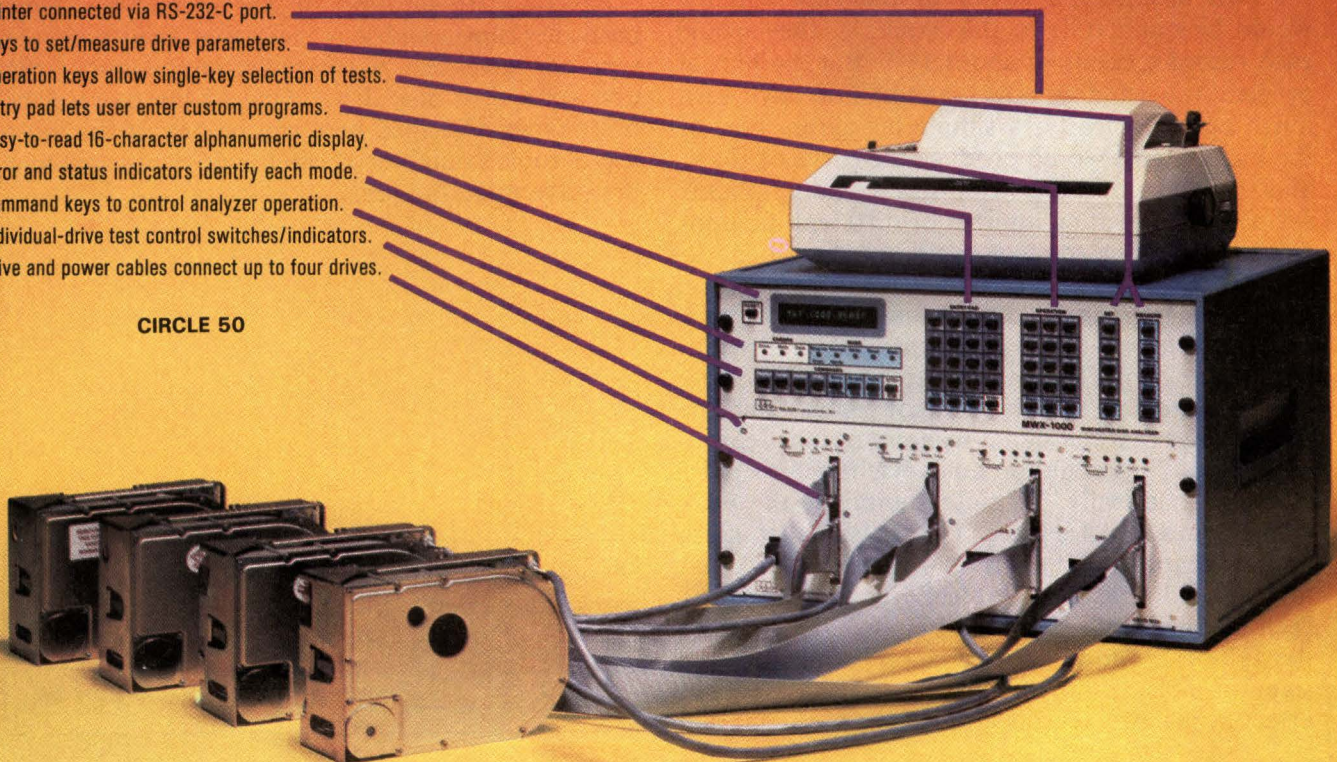

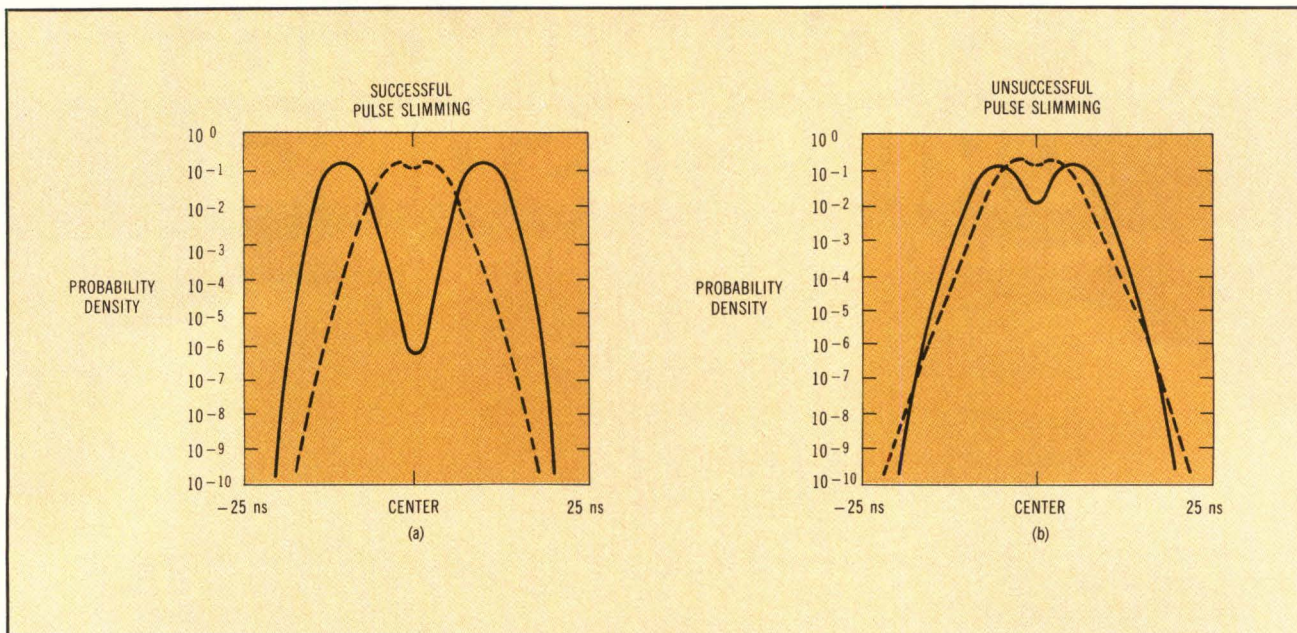

Fig 7 Pulse slimming is a trade-off technique whereby peak shift is reduced but signal-to-noise ratio is degraded. Plot (a) shows that successful slimming improves the margin. Plot (b) is not a good candidate for pulse slimming since the margin gets worse after slimming is applied.

One other margin analysis technique exists. The objective is to gather data to generate a typical transition distribution plot such as that shown in Fig 4. Assume that the data window is divided in 1-ns increments—50 increments as shown in the time base of Fig 4. Consider these increments to be 50 buckets or bins. Assume further that 10^{11} data bits are transferred, and on each transition, the occurrence is stored in its appropriate bin. For each transition that goes into a particular bin, the numerical count of that bin is increased by one.

At the test's conclusion, it would be likely that the bins around the center of the data window would be quite full. In this example, they would each record a count of about 10^{10} . But the bins at or near the window edges would not have seen much action. Clearly, a simple histogram plot of the bin contents would produce the curve of Fig 4, and the peaks in the distribution would be plainly revealed. There are a number of different methods for implementing the technique just described.

Applying margin analysis to disk drive design

Fig 7(a) illustrates a normal peak-shift distribution (solid line). The peak shift is well defined—approximately 10 ns either side of center—and the slope shows that the signal-to-noise ratio is reasonably good. This situation lends itself well to pulse slimming. Basically, in pulse slimming, the peak shift is improved (reduced) but the signal-to-noise ratio is degraded. The dashed-line plot shows that the peak shift has been reduced to about 2.5 ns on each side by pulse slimming but that the slope of the fall-off is now less steep, indicating that the signal-to-noise ratio has been degraded. The net effect at the 10^{10} level is an increase in the margin

from 5 to 8 ns on each side, so the technique is judged to be successful.

By contrast, the plot of Fig 7(b) shows an unsuccessful application of pulse slimming. The solid line curve here starts out with just 5 ns of peak shift on either side of center and a fairly poor signal-to-noise ratio. This gives the same result as in Fig 7(a), namely that the margin at the 10^{10} level is 5 ns on each side. However, pulse slimming reduces the peak shift from 5 to 2 ns, and again degrades the signal-to-noise ratio. But the overall result is a loss in margin at the 10^{10} level from 5 to 3 ns.

Several different types of margin analyzers have been described, and it is clear that even a simple type can give very useful information about the operation of a disk drive. One of the more elaborate types described here can be one of the most useful tools available to both the drive designer and the drive manufacturer.

Please rate the value of this article to you by circling the appropriate number in the "Editorial Score Box" on the Inquiry Card.

High 701

Average 702

Low 703

ANNOUNCING The Only Test System

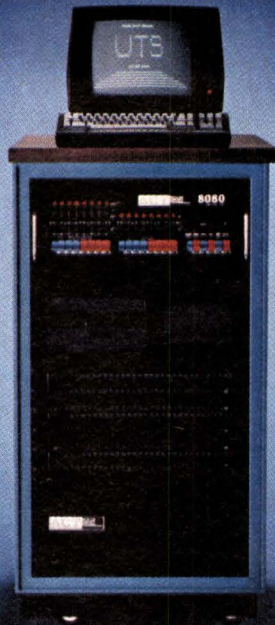

With *THREE* Personalities

- Disk Drive Manufacturers
- Computer Manufacturers
- System Integrators
- Final Production Test
- Receiving Test
- Engineering Development

- Hard Disk
- Floppy Disk
- Tape Devices

Applied Circuit Technology's UTS-Unit Test Station provides you with the expandability and sheer number of test slots to maximize your test room throughput while breaking the test room bottleneck. Each UTS comes configured to test 4 devices simultaneously. The optional networking capability allows the UTS to link up to 8 systems together in a master/slave configuration, providing simultaneous testing of up to 32 devices. The UTS' industry-leading design and electronics provide the power to perform any level of test required; therefore, insuring the performance and reliability of any rotating memory device. The UTS combines the highest degree of correlation of test results from slot to slot and system to system, and a detailed test data sheet with floppy back-up for archival purposes. The exclusive versatility of the UTS system will provide your testroom with a productive, useful tool.

Disk drive manufacturers can use the UTS to insure the throughput to make shipments while assuring final production reliability. Computer manufacturers and system integrators can use the UTS to insure drive and interface performance on incoming devices before they get into the production line, keeping productivity high. Engineering departments can use the UTS to test and verify prototype designs and to troubleshoot failed production units. Overall flexibility and portability (it's caster mounted) will make the UTS the most sought after test system in your company. Since the UTS is totally software-driven, applications can be changed in the time it takes to call up a new program. With the UTS' built-in 10 megabyte Winchester drive, the process is quick and easy. The UTS' ability to provide both hardcopy and floppy test results allows you to track and analyze failures.

By means of a simple board change, the UTS employs *all* of its power and flexibility to test any hard disk, floppy disk or tape device, regardless of interface, storage capacity or transfer rate. Applied Circuit Technology's systems today test more than 2,000 5¼" Winchester drives daily. They have greatly contributed to an under-3% return rate for manufacturers, and are quickly becoming the industry standard for rotating memory device test. The UTS system has no planned obsolescence . . . its three (or should we say nine) personalities allow the system to expand and fill the needs of your production, receiving or engineering departments with maximum efficiency and minimum conversion time. *The UTS is competitively priced while providing features the competition can't touch.*



**Applied
Circuit
Technology**

2931 La Jolla St., Anaheim, CA 92806
(714) 632-9230

Achieve the Standard with Applied Circuit Technology's UTS—The Only System with Three (nine) Personalities.

Regional sales offices: Westlake Village, CA (805) 496-8778; San Jose, CA (408) 287-8720; Boulder, CO (303) 466-1763



```
SET UP

MAIN PORT          19200
MODE              OFF
BAUD              19200
PARITY            OFF
DATA BITS         8
STOP BITS         1
DTP               OFF
XOFF/XOH          1
XOH =             1
ACK =             1

AUX. PORT         DIGIB
MODE              300
BAUD              300
PARITY            OFF
DATA BITS         8
STOP BITS         1
DTP               OFF
XOFF/XOH          OFF

BLOCK SEND        1
TRANSFER         1
FIELD MARK       1
LINE PROT.       1
START PROT.      1
END PROT.        1
END OF TEXT      1

DISPLAY           24
LINES/PAGE       1
BACKGROUND       60 Hz
REFRESH RATE     OFF
SCREEN SWEEP     SLOW 2
SCROLL            1
CHARACTER SET    1
CURSOR           ON
LINE TRUNCATE    OFF
AUTO LINEFEED    OFF
AUTO SCROLL      ON
AUTO PAUSE       ON
INSERT CHAR      1

KEYBOARD          OFF
BELL              OFF
CLICK            25
AUTO REPEAT      0.10
DELAY            1
EDIT             1
MODE            1
DUPLEX           1
SIMULATION       1
MODER            1
MARGIN BELL      1
COLUMN           1
```

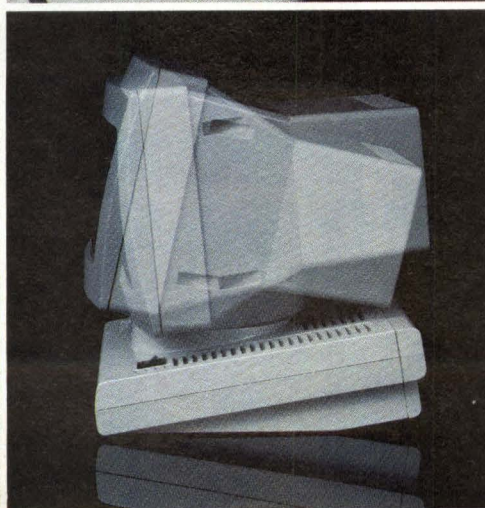
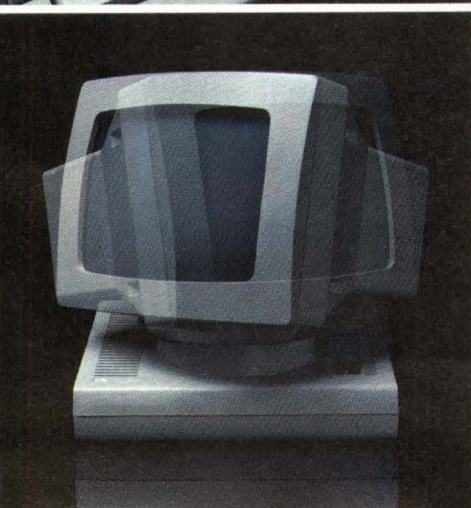
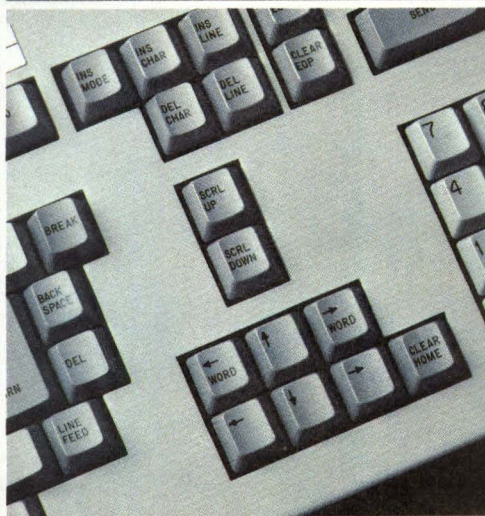
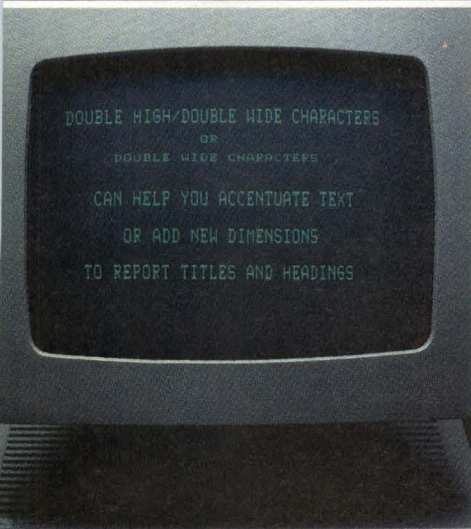
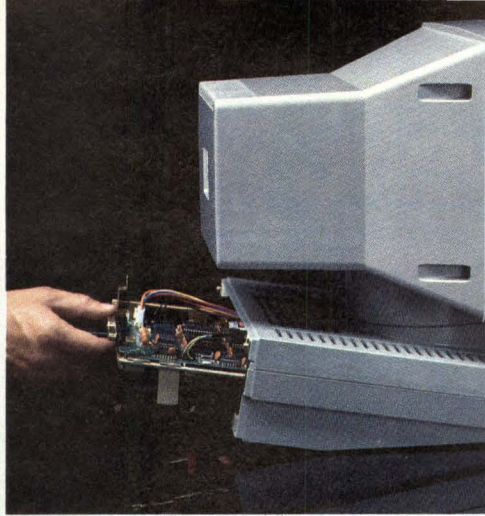
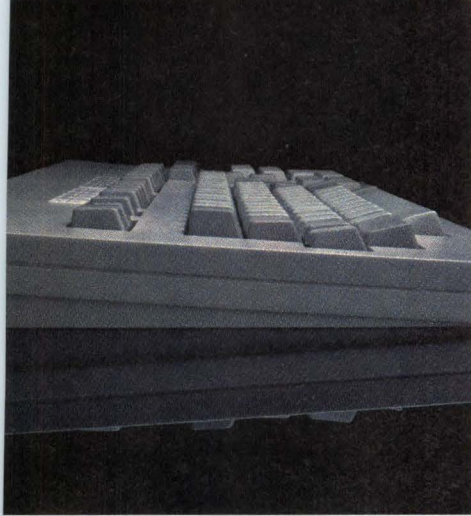

Introducing the Freedom 200. No other VDT gives you more, for less.

For only \$745, the Freedom 200 gives you more user-relevant functions and optimized ergonomic features than any other standard VDT.

You get 106 keys, clustered for maximum user efficiency.

Plus 10 user-programmable non-volatile function keys (256 bytes worth) for a host of applications.

Plus 11 cursor control keys, including tab by word for easy editing.

Plus flexible non-volatile set-up modes, full page or status line, to easily configure your terminal exactly the way you want it.

Plus user-definable smooth scrolling regions, with selectable scroll rates.

Plus split-screen capability.

Plus 128 ASCII characters, with 86 extended graphic characters for forms creation.

Plus non-embedded attributes (visual and data entry).

Plus double-high/double-wide characters.

Plus programmable answerback message for enhanced security.

Plus programmable time out, to prolong the life of your screen.

Plus easy serviceability, and space for add-on boards.

Plus two-page standard memory in emulation modes and one-page memory in native mode, with additional memory optional.

Plus 8 foreign character sets.

Plus TeleVideo 950 and Lear Siegler ADM 31 emulation.

Plus more.

To find out more, contact your local Liberty dealer or distributor.

Or call Liberty direct.

(415) 543-7000.

No other VDT gives you more, for less.

CIRCLE 52

 **LIBERTY**

© Liberty Electronics 1983.

WE'RE TAKING

GETTING TOMORROW'S SYSTEMS OFF THE GROUND TAKES YOUR INSPIRATION, A LOT OF PERSPIRATION AND THE MOST ADVANCED VLSI DEVICES IN THE WORLD.

Look forward with NEC.

Behind the NEC name happens to be one of the largest suppliers of microcomputers, microprocessors, gate arrays, analog and discrete devices, capacitors, fiber-optics, and fluorescent indicator panels in the world. So chances are, NEC has what you're looking for.

The NEC standard of excellence.

Our one megabit ROM, 256K DRAM, hard disk controllers, signal processors, two micron bipolar and CMOS gate array technologies are just a few ways our performance can improve yours. The highest quality-control standards, fast turn-arounds and on-time delivery are ways we keep you coming back for more.

Rely on the leader.

You have a partner at NEC. We have the products and resources to push your imagination to the limits.

**WE'VE SEEN THE FUTURE
AND WE'RE PUTTING IT TO WORK.**

For fast access to NEC resources, contact one of our national sales offices:
WOBURN, MA (617) 935-6339 · MELVILLE, NY (516) 423-2500 · POUGHKEEPSIE, NY (914) 452-4747 · POMPANO BEACH, FL (305) 785-8250 · LARGO, FL (813) 536-4702
· COLUMBIA, MD (301) 730-8600 · ARLINGTON HEIGHTS, IL (312) 577-9090
SOUTHFIELD, MI (313) 559-4242 · BLOOMINGTON, MN (612) 854-4443 · DALLAS, TX (214) 931-0641 · ORANGE, CA (714) 937-5244 · CUPERTINO, CA (408) 446-0650

© 1983 NEC Electronics

ON THE FUTURE.



NEC
NEC Electronics

DON'T COMPROMI



Regional Sales Offices:

Newport Beach, California, (714) 851-9964;
San Jose, California, (408) 286-7580;
Woodland Hills, California, (213) 884-2699;
St. Petersburg, Florida, (813) 577-1199;
Schaumburg, Illinois, (312) 397-3727;
Hopkinton, Massachusetts, (617) 435-6961;
Dallas, Texas, (214) 783-6711.
Authorized U.S. Distributors: Arrow Electronics,
Pioneer Electronics and Wyle Laboratories

European Sales Office:

Gassnerstrasse 5, 8000 Munich 19, West Germany, 49 89 177017, TELEX 524275 SEAG D

©1983 Seagate Technology

SE ON HALF-HIGHS

Introducing the fastest 5¼" 12MB half-high Winchester, the Seagate ST212, the rugged drive that manufacturers of portable and desktop computers have been waiting for. Now you can get a 65msec average access time drive that can withstand a 40G shock.



Don't compromise performance. Seagate's new ST212 is more than 15% faster than its nearest competitor. We also made it durable, reliable and manufacturable in volume, using improved oxide coated media and low-mass minislidder heads.

Don't compromise compatibility. Only Seagate's new ST212 single platter, four head design is completely hardware and software compatible with our ST412, the number one standard height drive. And for even greater systems performance, Seagate now offers its ST9000, a low-cost SCSI-based controller.

Don't compromise your Winchester standards. Only Seagate ships the widest range of 5¼" Winchesters in volume, and at prices OEMs can count on. In 1983, Seagate will ship more than 400,000 Winchester disc drives, all backed with a full one year warranty and our industry-leading "105% Guarantee" program.

Don't compromise. Call Seagate today. We're shipping ST212 drives in volume!



The Uncompromising ST212

Unformatted capacity (MB)	12.76
Formatted capacity (MB)	10
Average access time (ms)	65

"Turning the tide in disc technology"

Seagate 

920 Disc Drive, Scotts Valley, CA 95066, (408) 438-6550, TELEX 176455SEAGATESCVL

CIRCLE 54

COMPUTER DESIGN/January 1984 95

Is Your Unix Short Of Cache?

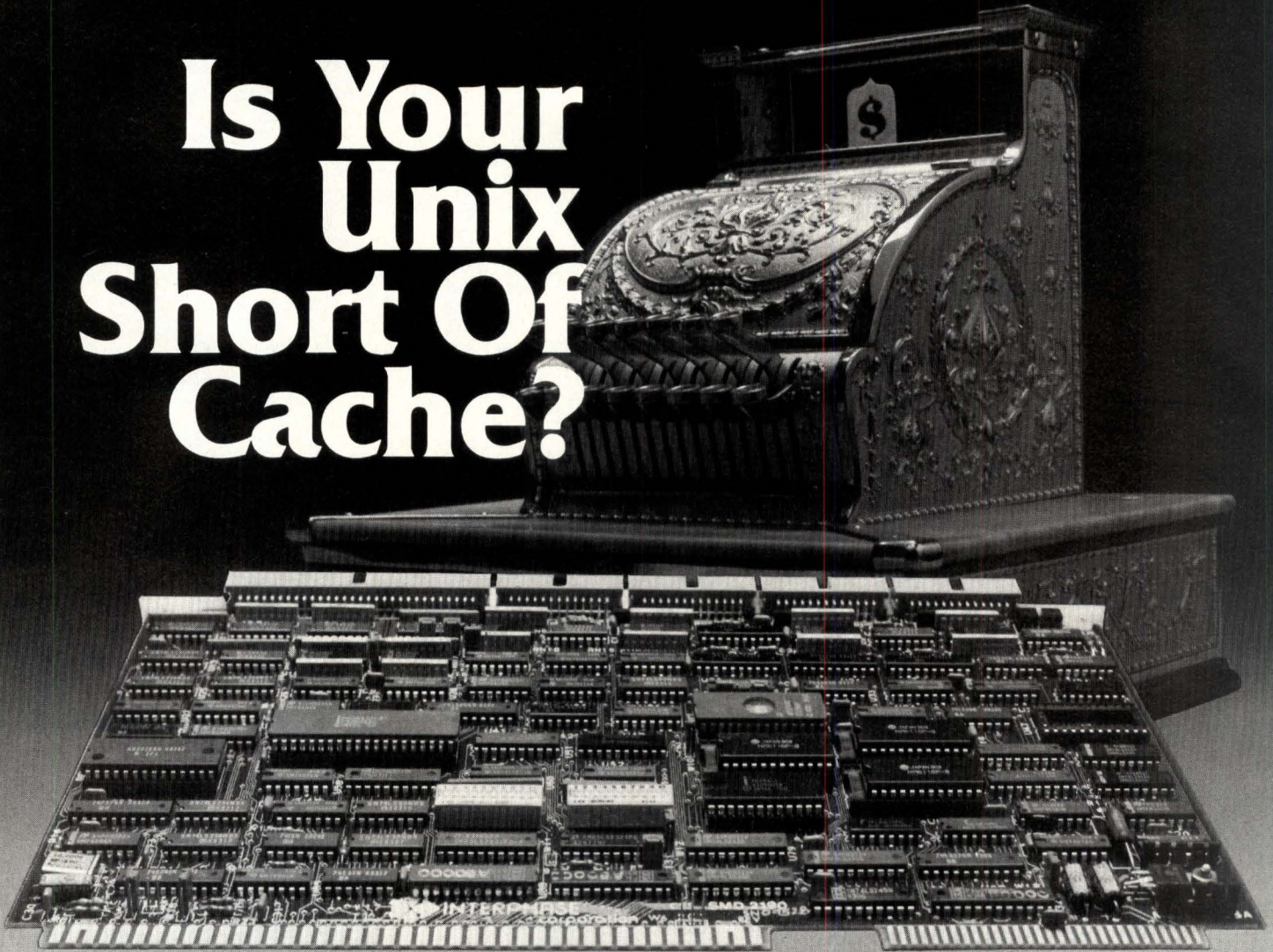

Presenting the first UNIX™ optimized SMD disk controller for Multibus.™ Available today from INTERPHASE.

The SMD 2190 is the first high performance disk controller optimized for UNIX and UNIX-like operating systems. Its highly intelligent caching scheme gives you the flexibility to match your disk controller to your operating system. This means optimum performance for all versions of UNIX.

With the SMD 2190, you get high speed cache memory plus all the features you've come to expect from a high performance disk controller.

1:1 Interleave, 20 Mb/S data rate, 32-bit ECC, Automatic Error Correction, Bad Track and Sector Mapping, and Overlapped Seeks for high performance on the disk side.

Ultra-high speed DMA, 8- and 16-bit data transfers, and both Relative and Absolute 24-bit addressing for high performance on the Multibus side.

Easy to use MACRO-level Commands — READ, WRITE, FORMAT — mean simple software drivers.

Most-Primitive Error diagnostic reporting and a low parts count mean minimum integration time and high reliability.

Software compatibility across the Interphase Family of SMD disk controllers means the maximum return on your software investment.

You've come to expect high quality innovations from Interphase... the most talented intelligent disk controller specialists in the country. And the SMD 2190 is no exception. It is elegant, well designed, affordable and available off the shelf.

But that's not all. We give you full support to help you integrate the SMD 2190 into your system. And we'll even leave some change in your pocket. Call or write us today.

UNIX is a trademark of Bell Laboratories.
Multibus is a trademark of Intel Corporation



INTERPHASE
corporation

2925 Merrell Road, Dallas, Texas 75229 • 214-350-9000 • Telex 73-2561 (TELESERV) DAL

DISK CONTROLLER CHIP RUNS ON SIMPLE SOFTWARE ROUTINES

Successful integration of programmable controllers into computer systems requires devices whose command set unburdens both the host processor and the system designer.

by David Davidian

As hard disk drives become the chief mass storage media for small and medium computer systems, a number of dedicated hard disk control ICs have emerged to offload the host processor's task in controlling hard disk drive operation. One of the latest ICs of this type is NEC's μ PD7261 hard disk controller (HDC). The chip is designed to control disk drives that support either a hard- or soft-sectored disk format. In addition, the HDC provides all control signals for interfacing a processor to a hard disk drive with a storage module device (SMD) interface, or to the popular floppy-like hard disk interface drives manufactured by Seagate Corp (ST506).

Programmable peripheral chips such as the 7261 have evolved to the point that the system integrator's task is concerned more with software rather than hardware aspects. Thus, designers must rely on the chips to offer sophisticated instruction sets that minimize both chip and processor overhead. Such software is provided in the 7261. For example, all data transfers to and from the disk are handled by the 7261 together with a DMA controller such as the NEC μ PD8237.

Features of the 7261 include user-programmable track format and the ability to control up to eight hard disk drives with SMD interfaces, or up to four

David Davidian is a software engineer at NEC Electronics USA, Inc, Microcomputer Div, One Natick Executive Park, Natick, MA 01760, where he is responsible for software integration of complex peripheral devices. He holds a BS in nuclear engineering from the University of Lowell.

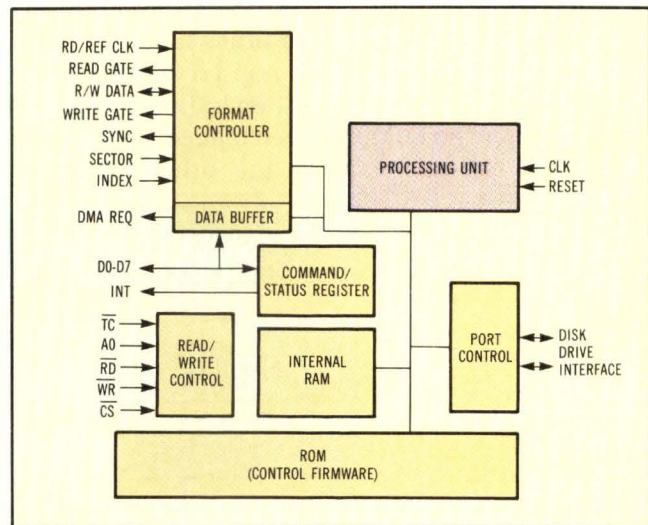

Fig 1 The architecture of the μ PD7261 HDC is centered around its processing unit, external interface and format controller. Disk data I/O operations are handled by the format controller, which executes instructions sent in by the host processor.

hard disk drives with a floppy-like interface. It offers parallel-seek capability, and multisector or multitrack data transfers. Data recording formats include modified frequency modulation (MFM) in the floppy-like disk mode and nonreturn-to-zero (NRZ) in the SMD mode. In the floppy-like mode, the maximum data transfer rate is 6 MHz, while in SMD mode, the rate is 12 MHz. Error diagnostic capabilities are either cyclic redundancy check (CRC) or error checking and correction (ECC).

As shown in the 7261 block diagram (Fig 1), the chip is partitioned into three major logical units: the command processor (processing unit), a format controller, and an external interface (port control). The command processor is an 8-bit microprocessor having its own RAM, ROM, and I/O interface. Its key

functions are to decode commands received from the host CPU, to execute seek and recalibrate commands, to monitor drive status and the interface, and to load the format controller with information appropriate for executing read/write data commands.

The command processor remains idle until it receives a command from the host. The format controller, a hardwired logic processor, executes high speed instructions sent in from the host—one instruction/clock cycle. This processor also handles a variety of tasks including serial-to-parallel and parallel-to-serial conversions from disk accesses, CRC and ECC generation and correction, MFM data encoding and decoding, write precompensation, address mark detection and generation, soft-sector identification (ID) field search and generation, and DMA transfer control.

Interfacing to the 7261 is handled on an I/O-port basis to the host processor. An onchip buffer/register is an 8-byte first-in, first-out (FIFO) type for command parameter loading and command end-result status reading. During DMA operations, the FIFO serves as a data buffer. Two other special registers are provided: the command register is a write-only type into which hard-disk operation codes are entered after the FIFO has been loaded with specific command parameters. On the other hand, the

status register is a read-only type that indicates the HDC's status at any time.

Talking to the HDC

Issuing commands to a μ PD7261 is a relatively straightforward operation. Assume, for example, that an input/output parameter block (IOPB), consisting of a command byte followed by command parameters, is previously stored in memory. To get this information into the HDC, the FIFO is loaded first (with the command parameters) and this is followed by the command byte.

The flowchart in Fig 2 illustrates the command loading sequence. First the user may want to set an "Interrupt Completion Flag." This allows the software to detect the completion of the command interrupt servicing. In essence, this indicates that the HDC has executed the command sent, irrespective of any errors. The next step is to issue an auxiliary command, such as the halt sense interrupt status request, to eliminate the possibility of interrupt servicing during command loading. Before the HDC will accept a new command (with the exception of auxiliary commands), bit 7 of the status register, called controller busy, must be low. This is indicated by the first decision block in Fig 2.

If the HDC can accept commands, parameters such as sector and head (for a read-data command)

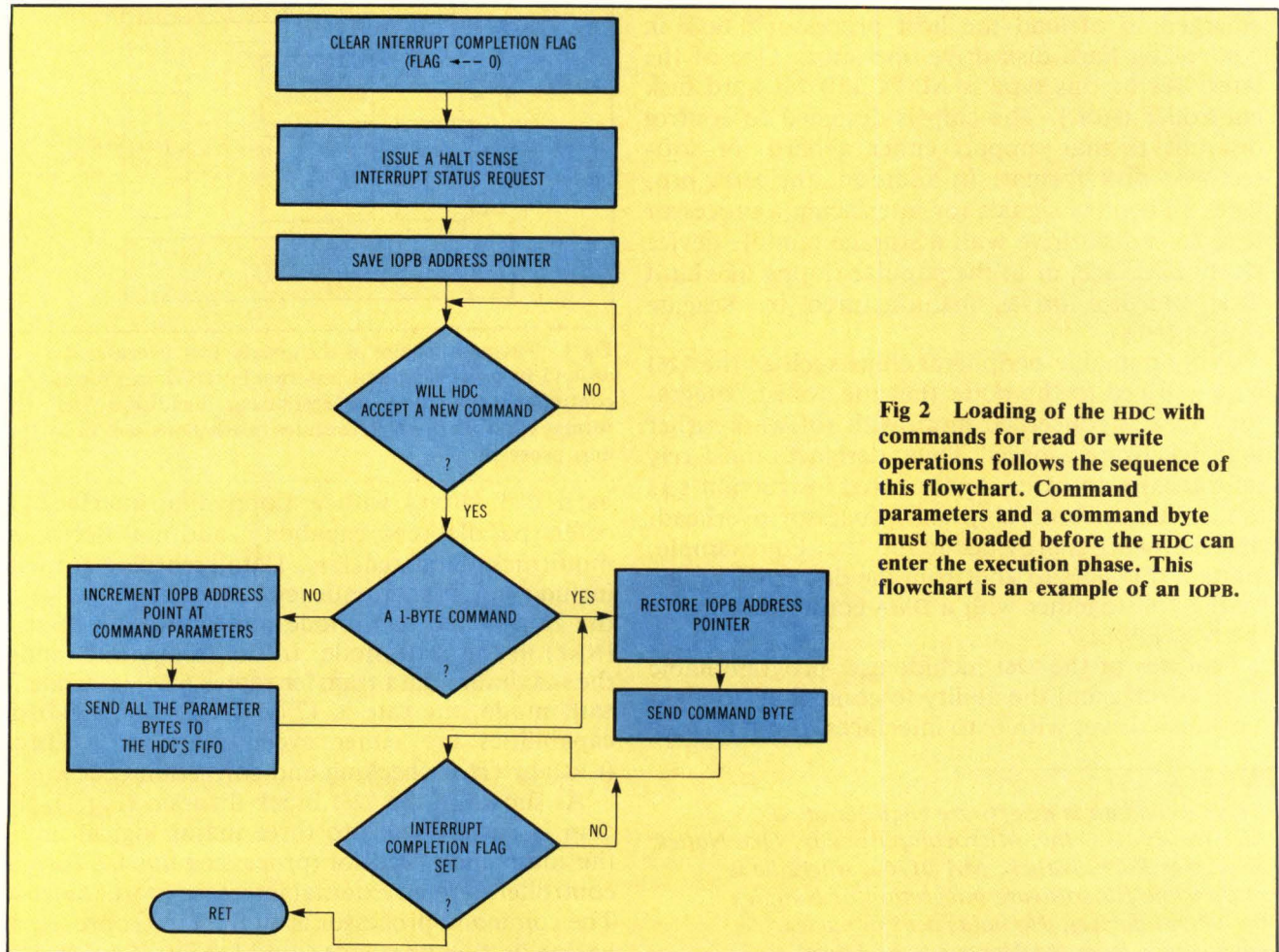

Fig 2 Loading of the HDC with commands for read or write operations follows the sequence of this flowchart. Command parameters and a command byte must be loaded before the HDC can enter the execution phase. This flowchart is an example of an IOPB.

NOW—SUPER-PERFORMING 5¼" WINCHESTERS WITH BUILT-IN RELIABILITY.

AVAILABLE NOW
21 or 36
MBYTE CAPACITIES.

TWO INTERFACE OPTIONS:
4.84 MHz (NRZ I/O data) or 5.0 MHz (MFM I/O data, compatible to ST506/ST412).
The transfer rates permit WREN to be matched with off-the-shelf controllers for easy systems integration.

ROTARY VOICE COIL ACTUATOR provides 45-millisecond average access time including head setting.

NEW
45 mSec
AVERAGE SEEK TIME.

HEADS never land on data areas. All WREN drives use a dedicated media zone for head take-off and landing.

UNIQUE SHOCK-MOUNTED BASE deck assembly isolates heads and media from external vibration. Automatic actuator restraint and manual shipping lock prevent head movement during shipment.

VERTICAL OR HORIZONTAL MOUNTING in the same space as a 5-1/4" FDD permits easy integration into FDD-based systems.

DEDICATED CLOSE-LOOP SERVO SYSTEM for added positioning accuracy and maximum system performance.

T H E W R E N™

The Model 9415 WREN disk drive gives you a host of value-added features. From microcomputer and LSI control logic to special-formula media, high technology has finally delivered a 5-1/4" winchester with more reliability.

Compare for yourself. Call your local Arrow or Kierulff distributor today. Or write: OEM Product Sales, HQN08H, Control Data Corporation, P.O. Box 0, Minneapolis, MN 55440.



GD CONTROL DATA

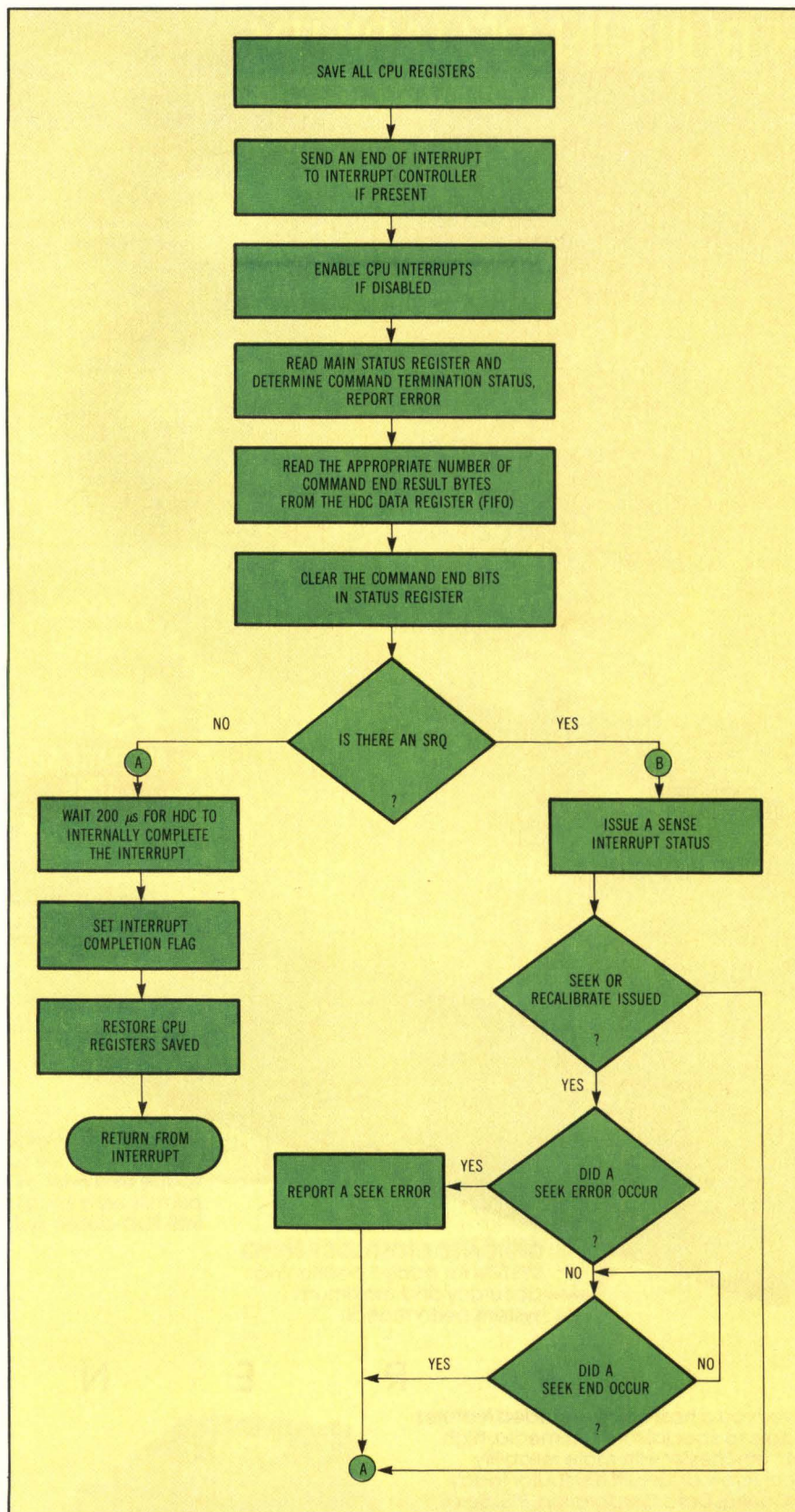

Fig 3 The HDC's interrupt service routine allows access to the controller's status at command completion. At command-end, the main status register indicates a normal or errored command execution and the need for an SRQ. Result bytes can be used to further describe any errors that occur. The proper interpretation of an SRQ completion is vital to the internals of the HDC.

are loaded into the FIFO. At completion, the command is loaded into the command register. This concludes the command phase of instruction execution and the 7261 proceeds to the execution phase.

The execution phase is verified by again referring to bit 7 of the status register. After execution, this phase is ended with either a normal or abnormal termination. An abnormal termination results from either a read or write error or a drive status change. A normal termination results from a correctly completed command. Command termination status is determined by reading the appropriate status register bits when directed by an HDC interrupt.

At the end of the execution phase, the HDC enters the result phase. Now the host can read various result parameters from the FIFO. These information bytes are useful for determining the cause of an interrupt and verifying command parameters initially sent with the command. Result-byte handling is a process usually performed at the interrupt level.

How to handle interrupts

Servicing command-end interrupts from the 7261 is the most important role of any software I/O driver set. At this time, the command's end status is determined. During this service routine, all error detection and correction, error reporting, and controller status information are available.

The flowchart in (Fig 3) shows that most of the interrupt process takes place after the appropriate registers are saved. If a priority interrupt controller chip such as the μ PD8259A is in the system, an end of interrupt (EOI) byte is issued to the chip. If the host processor disables interrupts during interrupt servicing (8086/88 microprocessors do this) then interrupts must be enabled to allow their nesting.

57.5 mm

MODELS MDD
423 & 413

33.5 mm

MODELS MDD 221 & 211

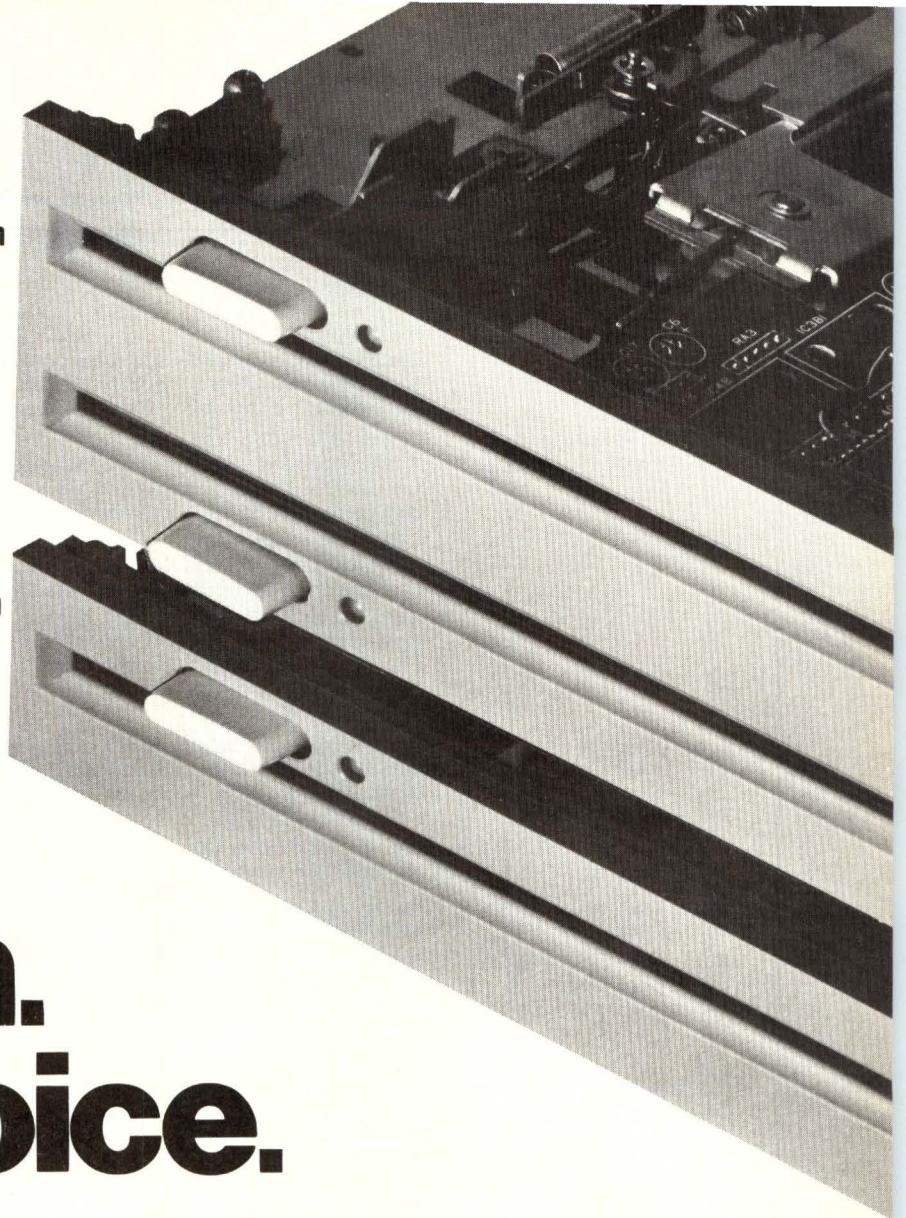

Canon. The choice.

Canon gives you lots of choices with their 5-1/4" floppy drives and lots of reasons why they should be your choice.

The choices:

- Standard half-height panels — or panels 20% thinner than half height: 33.5 mm.
- 96 TPI — or 48 TPI.
- Single drive — or double drive.
- Double drive with two stepper motors.

The reasons a Canon floppy drive should be your choice:

Our single drive is only 33.5 mm high — 20% less than a standard half-height drive; our double drive is only about two-thirds the height of a full size drive.

The single drives weigh 1.2 Kg, the double drives 1.9.

The single drives use 0.8A (12V and 5V); the double drives 0.9A (5V) and 1.3A (12V). As you can see, our double drives use 25% less power than two separate single drives — even ours!

Single-pushbutton media locking and ejection, and anti-crunch mechanism to prevent damage to improperly inserted media. Pushbutton is locked while heads are loaded, automatically.

Extremely thin wear- and shock-resistant head — designed and manufactured by Canon. Soft-landing head mechanism eliminates tap damage...brushless direct drive motor...low parts count...quiet operation...total head shielding...circuit design minimizes noise interference.

Further, our single drives can be used in existing designs because they're available with half-height front panels. The electronics of all our drives are compatible with an industry standard interface.

Canon offers its single drives with track densities of 96 TPI, double density, double side, which can store 1 Mbyte per disk; and its new 48 TPI-drive which can store 0.5 Mbyte per disk. Both of these are available, in quantity, now.

We have much more to tell you about these drives. Call Lee Heller at (516) 488-6700, Ext 4958, Canon U.S.A., Inc., Disk Drive Division, One Canon Plaza, Lake Success, NY 11042.

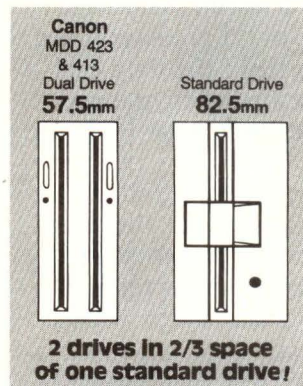
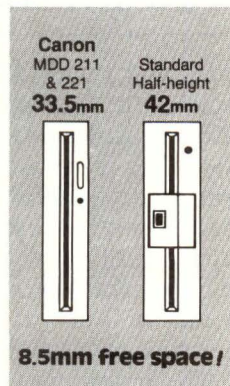

Canon
CIRCLE 57

TABLE 1
Contents of HDC Main Status Register

No.	Name	Bit Symbol	Description
D7	Controller Busy	CB	Set by a disk command issue. Cleared when the command is completed. (This bit is also set by an external reset signal or an RST command, but will be cleared at the completion of the reset function.) When this bit is set, a new disk command will not be accepted.
D6	Command	CEH	CEH = 0 and CEL = 0
D5	End	CEL	A disk command is in process, or no disk command is issued after the last reset signal or the last CLCE auxiliary command. Both the CEH and CEL bits are cleared by a disk command, a CLCE auxiliary command, or a reset signal. CEH = 0 and CEL = 1 Abnormal termination of a disk command. Execution of a disk command was started, but was not successfully completed. CEH = 1 and CEL = 0 Normal termination of a disk command. The execution of a disk command was completed and properly executed. CEH = 1 and CEL = 1 Invalid command issue.
D4	Sense Interrupt Status Request	SRQ	When a seek end, an equipment check condition, or a ready signal state change is detected, this bit is set requesting a sense interrupt status command be issued to take the detailed information. This bit is cleared by an issue of that command or by a reset signal.
D3	Reset Request	RRQ	Set when controller has lost control of the format controller (missing address mark, for example). An auxiliary RST command or another disk command will clear this bit.
D2	ID Error	IER	Set when a CRC error is detected in the ID field. An auxiliary RST or another disk command will reset this bit.
D1	Not Coincident	NCI	Set if the controller cannot find a sector on the cylinder which meets the comparison condition during the execution of a scan command. This bit is also set if data from the disk does not coincide with the data from the system during a verify ID or a verify data command. This bit is cleared by a disk command or a reset signal.
D0	Data Request	DRQ	During execution of write ID, verify ID, scan, verify data, or a write data command, this bit is set to request that data be written into the data buffer. During execution of read ID, read diagnostic, or read data command, this bit is set to request that data be read from the data buffer.

Determining the command termination status requires that the HDC's main status register be read to check for the appropriate bit setting. Table 1 lists the 8 bits of the main status register and their functions. Note that bits D5 and D6 are associated with the command end interrupts.

At this point, the command end bits must be cleared so they can be set by the next command. Further investigation on the cause of an interrupt—whether an error condition or a normal interrupt—can be carried out by reading out a predetermined number of result status bytes from the data register. Table 2 gives a complete listing of the result bytes and the number of bytes that must be read, depending on the command. The status register's condition, together with the result byte, allow the interrupt service routine to determine the exact cause of an error and the action that must be taken.

To determine if a sense interrupt status request is necessary, the SRQ bit in the main status register must be checked. If set, the result byte generated is the interrupt status. Typically, this byte indicates the successful termination of a seek or recalibrate. This allows the next command to be issued to a

particular disk drive. Usually, the command is a data transfer such as a read or write data.

Because of HDC processing requirements and the initialization necessary for the completion of a specify command, a special command-end sequence is used. Immediately after the issuing of a specify

Interfacing to the 7261 is handled on an I/O-port basis to the host processor.

command, and within the first several polling cycles, up to nine interrupts can be generated. These must be processed by both the host and the 7261. One interrupt is for the command end, and four others establish the present drive status. Setting the SRQ bit can cause up to four additional interrupts, and this requires a sense interrupt status bit to be generated for each drive that is not ready. A certain amount of time is required between each interrupt to allow for 7261 servicing.

The amount of delay necessary for the 7261 to catch up on its interrupt servicing depends on the type of host processor used and its clock rate. The

TABLE 2
Command and Result Bytes of the HDC

Disk command	Command code	Preset Parameters/Result Status							
		1st	2nd	3rd	4th	5th	6th	7th	8th
DETECT ERROR	0100X	EADH	EADL	EPT1	EPT2	EPT3			
RECALIBRATE	0101[B]	IST*							
SEEK	0110[B]	PCNH IST*	PCNL						
FORMAT WRITE	0111(S)	PHN EST	(PSN) SCNT	SCNT	DPAT	GPL1	[GPL3]		
VERIFY ID	1000(S)	PHN EST	(PSN) SCNT	SCNT					
READ ID	1001(S)	PHN EST	(PSN) SCNT	SCNT					
(READ DIAGNOSTIC)	1010X	PHN EST	PSN						
READ DATA	1011X	PHN EST	(FLAG) PHN	LCNH (FLAG)	LCNL LCNH	LHN LCNL	LSN LHN	SCNT LSN	SCNT
CHECK	1100X	PHN EST	(FLAG) PHN	LCNH (FLAG)	LCNL LCNH	LHN LCNL	LSN LHN	SCNT LSN	SCNT
SCAN	1101X	PHN EST	(FLAG) PHN	LCNH (FLAG)	LCNL LCNH	LHN LCNL	LSN LHN	SCNT LSN	SCNT
VERIFY DATA	1110X	PHN EST	(FLAG) PHN	LCNH (FLAG)	LCNL LCNH	LHN LCNL	LSN LHN	SCNT LSN	SCNT
WRITE DATA	1111X	PHN EST	(FLAG) PHN	LCNH (FLAG)	LCNL LCNH	LHN LCNL	LSN LHN	SCNT LSN	SCNT
SENSE INTERRUPT STATUS	0001X								
SPECIFY	0010X	IST MODE	DTLH	DTLL	ETN	ESN	GPL2	[MGPL1] [RWCH]	[RWCL]
SENSE UNIT STATUS	0011X	UST							

(a)

Definitions	
EADH	Error Address, High Byte
EADL	Error Address, Low Byte
EPT1	Error Pattern, Byte One
EPT2	Error Pattern, Byte Two
EPT3	Error Pattern, Byte Three
PCNH	Physical Cylinder Number, High Byte
PCNL	Physical Cylinder Number, Low Byte
PHN	Physical Head Number
PSN	Physical Sector Number
SCNT	Sector Count
DPAT	Data Pattern

(b)

Auxiliary Command

Bit name	Operation
CLCE	Clears the CE bits of the status register, inactivating the interrupt request output caused by Command End condition. This is used when no disk commands are going to be issued and it is desired to clear the interrupt.
HSRQ	Deactivates the interrupt request output caused by Sense Interrupt Status Request condition until a Command End occurs. However, this command has no effect on the SRQ bit of the status register.
CLB	Clears the data buffer.
RST	This has the same effect as a reset signal on the Reset input. This function is used whenever the RRQ bit in the status register is set (indicating the format controller is hung up), or when a software reset is needed.

(c)

Note: (): These are omitted for soft-sector disks.
[]: These are omitted for hard-sector disks.
*: IST available as a result byte only when in nonpolling mode.

B: Indicates buffered mode when set.
S: Indicates skewed mode (SMD only) when set.
X: Indicates don't care.

program (Table 3) shows that an Intel 8086 microprocessor operating at a 5-MHz clock rate imposes a 200- μ s delay between 7261 interrupts. The faster the host executes code, the greater the delay time between interrupts. A 5-MHz 8088 microprocessor,

for example, imposes no delay on the 7261 because its execution time is longer than the 8086's interrupt servicing time. In general, there is no significant reduction in performance by inserting delays during interrupt servicing.

TABLE 3
The HDC Interrupt Service Routine

```

INTRPT:
    PUSH    AX    ;SAVE
    PUSH    BX    ;ALL
    PUSH    CX    ;THE
    PUSH    DX    ;REGS
    PUSH    BP    ;THAT
    PUSH    SI    ;MAY
    PUSH    DI    ;GET
    PUSH    ES    ;KILLED
    PUSH    DS
    CALL    SEND_EOI_TO_8259
    STI     ;ENABLE INTRs FOR S.LS'S DURING INTRs
    CALL    READ_MAIN_STATUS_REPORT_ERRORS_CLEAR_COM.END
    CALL    READ_RESULTS    ;FROM FIFO
    TEST   MAIN_STATUS_STORAGE,10H ;CHK for AN SRQ
    JZ     END_INTR ;IF NO RQS AND SINCE WE HAVE READ FIFI-EXIT
    CALL   ISSUE_SENSE_INTR_STATUS ;IF RQS SET DO A S.LS
    CALL   CHK_FOR_SEEK.END

END_INTR:
    CALL   WAIT_FOR_HDC_INTERNALS
    MOV    INTR_COMPLETION_FLAG,1 ;SET THE INTR DONE FLAG
    POP    DS    ;RESTORE
    POP    ES    ;REGS
    POP    DI    ;SAVED
    POP    SI
    POP    BP
    POP    DX
    POP    CX
    POP    BX
    POP    AX
    IRET

```

At this point, interrupt servicing in the HDC is complete. The restoration of the CPU registers and a return from interrupt signal indicate the completion of interrupt servicing.

Initializing the HDC

The specifying or initializing of the 7261 depends largely on hard disk media specifications, interface type, and operating system requirements. An 8-byte parameter set is sent to the HDC with the specifying command. Of these, the most important is the mode byte.

Bit 7 of the mode byte is always a logic 1, while bit 6 selects either CRC or ECC error-correction. Bit 5 determines the generating polynomial for ECC operation. The remaining 5 bits set the head servo's stepping rate.

The typical track formatting arrangement for both hard- and soft-sectored disks is shown in Fig 4. Within the data length high (DTLH) byte, the polling (POL) bit determines whether the 7261 is in polling or nonpolling mode—a logic 0 indicates polling. In polling mode, the ready status of each drive is continually queried and updated. Drives are polled for status information when the 7261 is idle and in between step pulses. A change in the status of any drive is reported immediately through an interrupt—the SRQ bit is set. In the nonpolling mode, the selected drive is first polled and then accessed. Also in this mode, the seek and recalibrate commands

have the interrupt status byte available to them as a result byte. Normally, the result byte is available only as a result of a sense interrupt status signal.

The data length low (DTLL) byte together with the lower 4 bits of the DTLH byte constitute a 12-bit value that represents the number of bytes/sector on the disk. For example, if DTLL is 0 and DTLH bit-8 is set high, the number of bytes/sector is 256.

Data transfers to and from the disk must be supported by high speed logic external to the 7261. The most accepted technique is the use of a DMA controller such as the μ PD8237. Data transfer rates for floppy-like interfaces are 1.6 μ s/byte, and 0.9 μ s/byte for SMD interfaces. Conventional NMOS microprocessors cannot handle such high data rates, thus requiring the assistance of a DMA controller or another form of high speed logic.

A "seek and read" operation

One way to illustrate HDC operation is by reading a data sector from the disk and transferring it to user memory. A read-data operation involves setting up the DMA controller, issuing a seek to a track, and issuing the read-data command.

As shown in Table 3, the 8237 DMA controller is sent a master internal reset initially, and this is followed by the clearing of the mask register. A number of assumptions must be made to describe the read operation, and these may vary if a different type of HDC/DMA hardware implementation is used.

Take it from someone who comes from a long line of card readers:

"Let me tell your fortune. I see you are searching for something. You have very high standards, very demanding needs. You are looking for a card reader of outstanding quality and reliability.

"Seek no further, stranger. Panasonic has the complete line of Optical and Magnetic Card Readers and systems to satisfy your needs.

"Quality Optical Badge Readers, in both vertical and horizontal versions, with or without automatic card ejection. A uniquely designed Automatic Magnetic Card Reader, built for strength, durability and precise operation. And a choice of budget-priced Manual Magnetic readers/writers, offering precision performance and easy operation in a compact, versatile package.

"The Optical Readers are capable of reading from 20 to 264 bits. And the Magnetic Readers can read up to 119 characters.

"Which one to choose? Let me make it easy for you . . . just consult my chart.



Model Number	Card Standard
Manual Magnetic	
ZU-1401	ISO1 (IATA)
ZU-1402	ISO2 (ABA)
ZU-1420	ISO1/ISO2
ZU-1601E	ISO1 (IATA)
ZU-1602E	ISO2 (ABA)
ZU-1601	ISO1 (IATA)
ZU-1602	ISO2 (ABA)
Magnetic Encoders	
ZU-2401	ISO1 (IATA)
ZU-2402	ISO2 (ABA)
Automatic Magnetic	
ZU-1507	ISO2 (ABA)
ZU-1521	ISO1 (IATA)
Horizontal Optical Reader	
ZU-XXXHR*	Type II, III
Vertical Optical Reader	
ZU-XXXVR*	Type II, III, IV, V

*XXX indicates number of bits

"It is your good fortune that you came to me. Now you will want to know more. To learn about the long line of Panasonic Card Readers, you must contact Panasonic Industrial Company, Office Automation Dept., One Panasonic Way, Secaucus, N.J. 07094; call (201) 348-5337 or in Chicago (312) 364-7900 ext. 326."

"There's a Panasonic in your future."

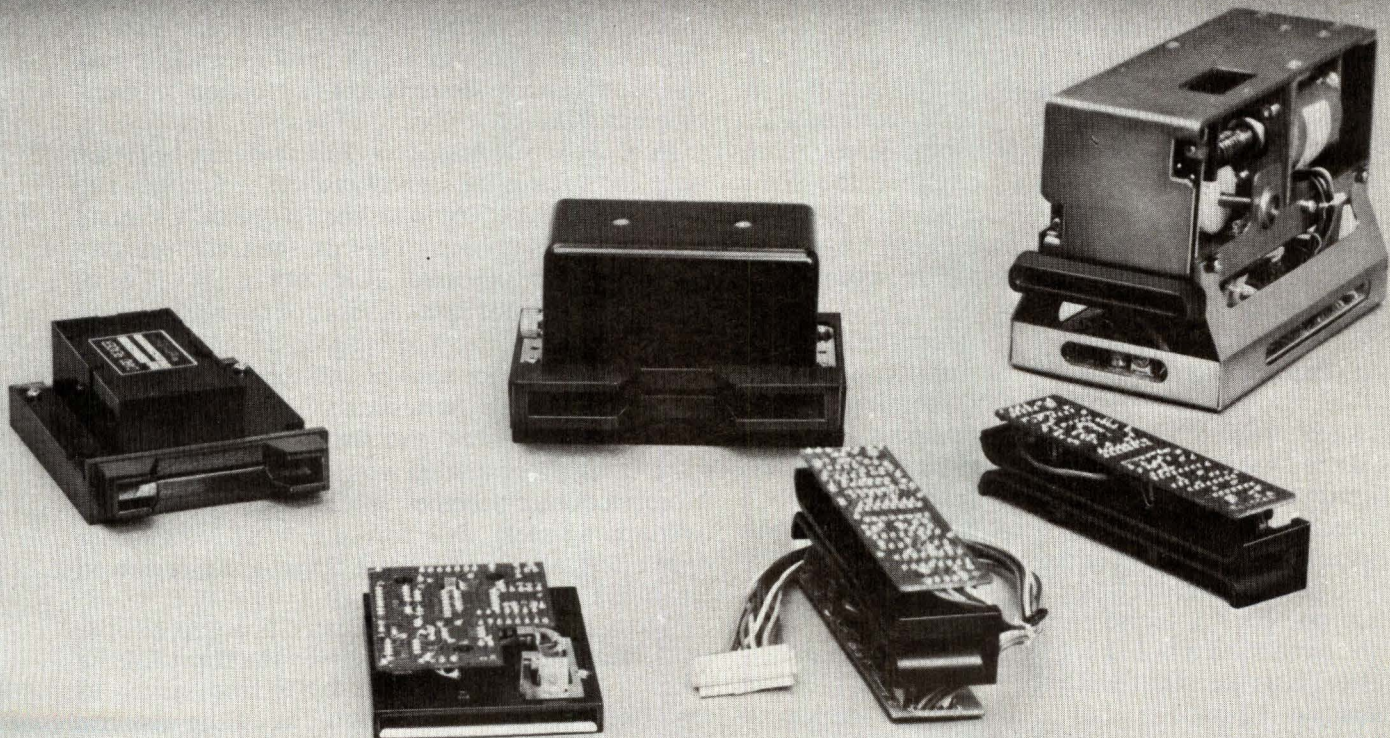

Panasonic[®]
just slightly ahead of our time

CIRCLE 58

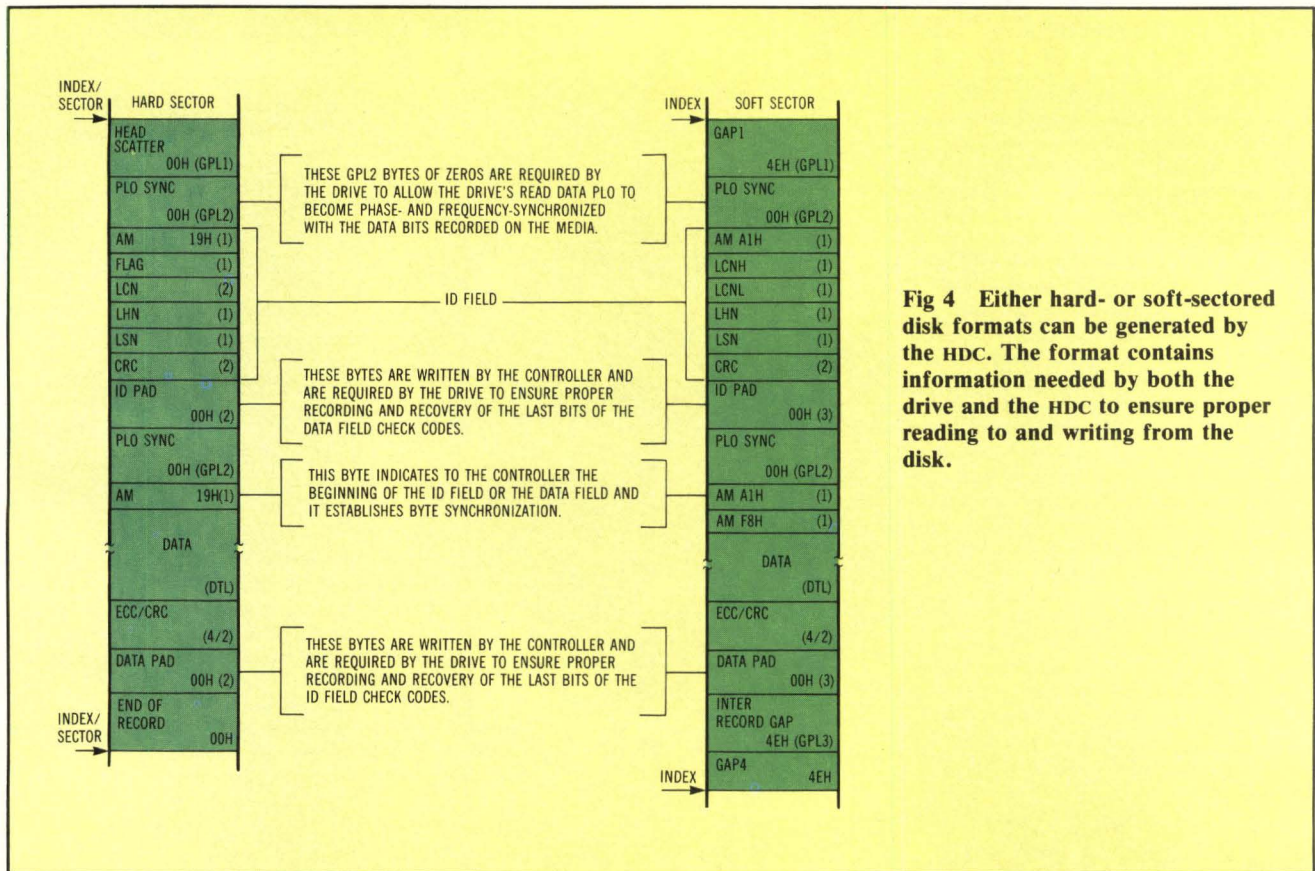

Fig 4 Either hard- or soft-sectored disk formats can be generated by the HDC. The format contains information needed by both the drive and the HDC to ensure proper reading to and writing from the disk.

In this example, assume the following conditions: an extended write operation is required, the data acknowledge (DACK) line is active low, data request (DREQ) is active high, the memory-to-memory transfer is disabled, channel-0 hold is disabled and channel 3 of the 8237 will be used. The command byte required is 20 hex. And the channel-3 mask position bit in the all-mask register must be cleared. Next, the channel-3 terminal count is sent to the 8237's channel-3 terminal count register. This is the number of bytes to be transferred minus 1 byte. For this example, the terminal count is actually the number of bytes/sector minus 1.

The channel-3 base address register then receives the base address of the memory to which the disk data will be transferred. Finally, the mode byte is issued to the 8237, and based on channel use and the HDC's characteristics, the mode byte is 07 hex. As hardware handshaking proceeds, the 8237/7261 will transfer data from the disk to the memory location specified by the base address.

Using subroutine HDC.COM, the seek command's parameters are loaded into the 7261's FIFO. Then the command byte is loaded into the command register. Assume that the object is to seek to physical cylinder 1 (track 1). This means that the IOPB must consist of the seek command byte and 2 address bytes for the physical cylinder. The HDC.COM routine requires the address of the IOPB with respect to the present data segment, and the number of bytes required for the command—three in this case.

Once the command and its parameters are loaded in the HDC, the required number of step pulses and their direction are issued to bring the head to the specified track. When the head arrives at track 1, the HDC sends out a seek-end interrupt and the host will service this as described in the section on interrupt handling.

Now the actual read-data command can be issued since the DMA is initialized and the seek command is complete. HDC.COM loads the FIFO with command parameters describing where on the track the data to be accessed is located. Then HDC.COM will issue the read-command byte. A return to the calling routine occurs only after a software handshake between the interrupt service routine and the interrupt completion flag. This handshake, together with the seek issued and seek end flags prevents the HDC from being programmed while a seek is in progress. More elaborate schemes can be used for multiple overlapping seeks, but for single-disk, single-user operations, the use of these flags is the preferred technique.

When the read-data command is accepted, the HDC immediately begins to survey the track for the specific sector address or ID bytes from which to read data. If after two revolutions of the disk the correct ID is not found, an error condition occurs, followed by an interrupt to the host. If the correct sector is found, data begins to flow into the FIFO and DMA transfers take over the data transfer operation. Data transfers then continue until the read

FREE VAX

If you're trying to support more than 4 programmers doing 8086- or 8080-family software with stand-alone microprocessor development systems, here's a way to increase your productivity 25%:

Buy our MicroSET-86™ or MicroSET-80™ software cross-development tools and a DEC VAX or DG MV/Family system to run them on. You'll save enough on your first major project to pay for the computer system.

Of course, if you already have access to a VAX (or MV or any IBM-compatible mainframe), you're that much further ahead.

People with experience in cross-development know it's the best way to tackle big software projects. And only First Systems' MicroSET gives you the industry's most complete, most powerful cross-development tools, plus your choice of five efficient systems implementation languages.

THE ONLY COMPLETE MULTILINGUAL DEVELOPMENT SYSTEM FOR THE 8086 FAMILY

MicroSET-86 lets you program in four powerful high-level languages: Pascal, C-86, FORTRAN-86, and PL/M-86.

An assembler is also available, although First Systems compilers generate such fast, compact code that you may find you have little need for it (benchmark data available on request). You also get a linker/locater that allows combining modules written in different languages.

Using our high-level Cross-Debugger to control execution on the target system, you can locate, fix, and re-test an erroneous line of code in a fraction of the time it takes using

other methods. It's no wonder that MicroSET users routinely shave months off typical development schedules — while producing more reliable, more maintainable systems.

MicroSET-86 supports the entire 8086 family: 8086/8088/186/286 and 8087. It works with in-circuit emulators you may already own, and has a complete set of host-target communication programs and other valuable utilities not available elsewhere.

ANNOUNCING NEW LANGUAGE-COMPATIBLE 8-BIT TOOLS

First Systems now supports cross-development of 8080/8085/Z-80 software with MicroSET-80, consisting of PL/M-80 compiler, assembler, linker/locater, cross-debugger, plus utilities.

Request complete information today. And take the first step toward your own free computer.

Intel is a trademark of Intel Corporation.

VAX is a trademark of Digital Equipment Corporation.

Z-80 is a trademark of Zilog, Inc.

© 1983 First Systems Corp.



First Systems Corporation™

Products for productivity.

865 Manhattan Beach Blvd.,
Manhattan Beach, CA 90266

(213) 546-5581

TELEX: 298086 FIRSYS

Data transfers to and from the disk must be supported by high speed logic external to the 7261.

operation is terminated by a terminal count interrupt from the DMA controller, or until an error condition occurs as indicated by the error status byte. If no errors occur, disk data has been transferred via the DMA controller to the user's memory.

Simplifying system integration

The overwhelming majority of commands issued to the HDC in a system environment are read data, write data, and seek. Thus, in a single-user system, the HDC/DMA read/write data buffer can occupy one location in memory. If the same buffer serves both to read from and write to the disk, the only difference between a read-data and write-data command is the DMA transfer's direction. This is controlled by the direction bit in the mode register, and the read/write data command at the top of the IOPB. This assumes that a seek to a specified track is not necessary.

Obviously, the HDC must be able to access any track and sector on a disk. This can be accomplished

by embedding all seeks to tracks in a common read/write routine. From a system standpoint, the only variables subject to change on a disk access—read or write data—are the head number, track number, starting sector and the number of sectors to be accessed sequentially.

From these variables, a call to a Common-Read-Write-Module establishes a specific IOPB based on the specified parameters. The DMA terminal count and direction of data transfer—read or write—are established as passed parameters for setting up the DMA controller. The track to be accessed is used as the parameter to be passed to an embedded seek to track. This seek is transparent to the user. The user's IOPB is then copied to the HDC COM's IOPB location and the HDC-COM loads the seven read or write data command parameters and the command byte into the HDC.

Please rate the value of this article to you by circling the appropriate number in the "Editorial Score Box" on the Inquiry Card.

High 704

Average 705

Low 706



GRAPHICS-PLUS is a field installable enhancement board for the popular Zenith¹ Z19 video terminal adding many powerful features found only on terminals costing much more. GRAPHICS-PLUS provides Tektronix² 4010 compatible vector drawing graphics, VT100³ compatible 80 and 132 column display formats, off-screen scrolling memory, programmable function keys, "Plain English" menu-driven Set-up mode, and a host of other enhancements. Installation can be accomplished within 15 minutes using only a screwdriver.

GRAPHICS-PLUS
an enhancement
For Z19 Terminals
from
Northwest Digital Systems

- Tektronix² 4010 Compatible Graphics
- 512 Horiz by 250 Vert Resolution
- 80/132 Col and 24/49 Line Text Displays
- Seven Page Off-Screen Text Memory
- Menu-driven "Plain English" Set-up Mode
- 16 Programmable Keys- 128 Chars Each
- Optional Hardcopy Port
- Simple Field Installation

1 TM Zenith
2 TM Tektronix
3 TM DEC

GP-19 Upgrade for Z19 Terminal	\$ 849
Z19 Terminal With GP-19 Installed	\$ 1495

Northwest Digital Systems

P.O. Box 15288, Seattle, WA 98115 (206) 362-6937

MEMORY LANE

A confident Multibus, VERSAbus, VME or LBX route when you travel it with Plessey Microsystems.

When it comes time to make that ultimate purchasing decision for memories for your system, confidence in your supplier should be priority one. If that's your kind of thinking, Plessey Microsystems is your kind of memory company.

Sure, we've got the most advanced technologies designed into our boards. And yes, we've got a full range of memories for VERSAbus* and Multibus† Systems, as well as VME, LBX and Multibus II on the road. Even supersmart memories with complete error detection and correction and up to 1 Mbyte on a single card. And, by the way, our boards meet the bus specs better than the bus designers'.

And it's true that our pricing is a pleasant surprise . . . even more so when you stack our features and our prices up against the competition.

But let's face it. In the final analysis, it's the company behind the boards that you have to feel good about. At Plessey Microsystems, superior memory technology and value are just pieces of the Plessey package. Consider, too, our consuming commitment to quality, reliability, delivery and technical support services. Thus . . .

Every Plessey memory has a one year warranty. Plessey memories are double sourced by Plessey both here in America and in Europe. To the same demanding, faultless specs. Every Plessey memory is stocked in enough depth to meet all but the most unusual requirements. And every Plessey memory has full Plessey support worldwide.

For your VERSAbus, Multibus or other systems, Memory Lane can be a tortuous route or a confident path. At Plessey

Microsystems we know the way. After all, we've been making memories since computers needed them, and we still offer the most advanced core, semiconductor and bubble memory technologies in the world. Plus the custom design and application expertise you'd expect from the super micro memory leaders.

For details on our standard products or custom capabilities call toll-free or write Plessey Microsystems, Inc., One Blue Hill Plaza, Pearl River, NY 10965. (914) 735-4661 or (800) 368-2738.

*™ Motorola †™ Intel



**PLESSEY
MICROSYSTEMS**

The Plus in Your System.

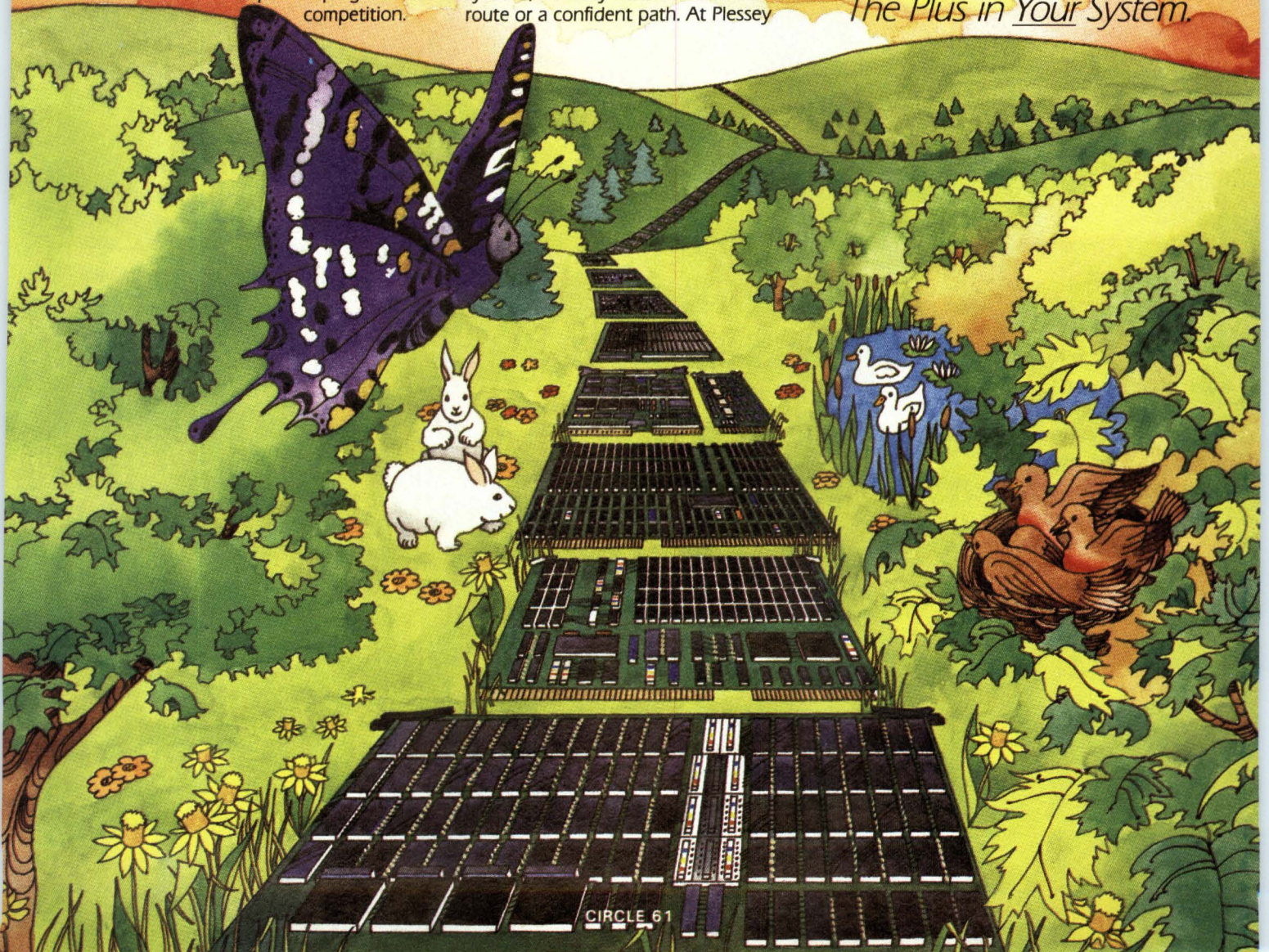

Our reputation on the line

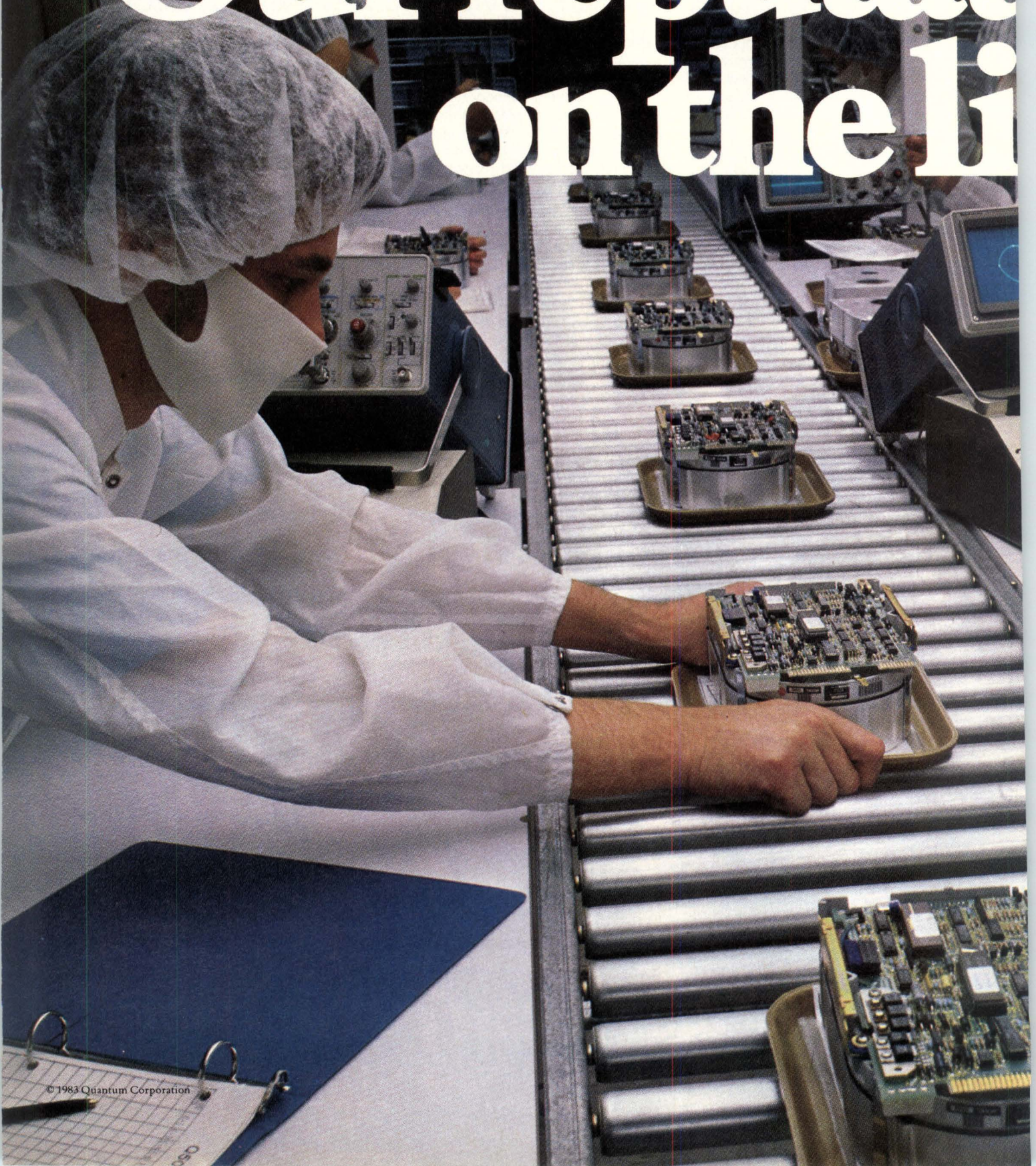

ion is ne.

We're a manufacturing company. Our engineers are manufacturing engineers. And our assemblers know that our reputation, and your system's, are in their hands.

Our strategy is simple. We build reliable disk drives, in volume. We've concentrated on perfecting the medium capacity Winchesters you need, now. 8" drives, from 10 to 85 megabytes; 5¼" drives, from 20 to 40 megabytes. By *perfecting*, we mean as perfect in 10,000 of your systems as they were in one demonstration unit.

We start with a cleaner design. Fewer parts. A design that can be assembled smoothly, tested effectively, and produced in volume without compromising quality.

Our production techniques, like our Winchesters, are a highly refined blend of experience and innovation. The "clean tunnel" approach we pioneered, for example, is less costly, more flexible, and yet just as free of contaminants as standard clean rooms. The modular sections can be expanded, duplicated or rearranged around changing production needs.

We'd like an opportunity to show you why we're so confident about putting our reputation, and yours, on the line. Give us a call.

Quantum Corporation, 1804
McCarthy Boulevard, Milpitas, CA
95035. Eastern Regional Sales Office:
Salem, NH, (603) 893-2672. Western
Regional Sales Office: Santa Clara, CA,
(408) 980-8555. International Sales
Office: Milpitas, CA, (408) 262-1100.
TWX: 910 338-2203.

QUANTUM

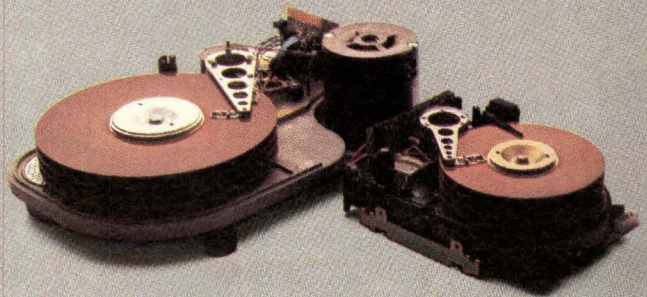

CIRCLE 62

WHAT'S HALF THE SIZE AND HAS THREE TIMES THE CAPACITY OF A DEC RL02? HERE'S A HINT.

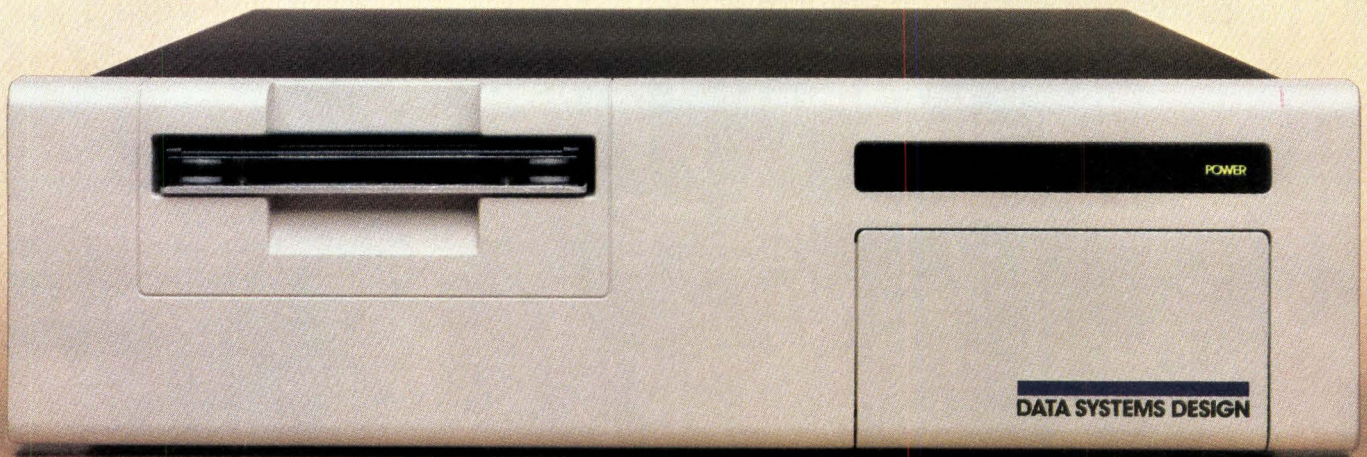

Now for the answer: the DEC[®]-compatible DSD 800 Winchester Series. With your choice of tape or floppy back-up.

No doubt you're familiar with the DEC RL02.

You can't miss it, really.

It's big. Bulky. And it's been around for ages.

Enter the ingenious DSD 800 Winchester Series.

It's compact. Fast. And based on one of the most reliable storage technologies to date—the Winchester disk drive.

A better than 3 to 1 ratio in your favor.

Now you can replace a rack full of RL02s (3 to be exact) with one DSD 880 or 890 storage device.

Because in a box just 5¼" high, you get a choice of capacities: 7.8, 20.4 and 31.2 Mb. Plus higher reliability.

Choose tape or floppy back-up.

The DSD 880 Winchester/Floppy offers a choice of 0.5 or 1 Mb floppy back-up. And standard 8" media.

For quicker, more convenient archival storage, you can choose the DSD 890 Winchester/Tape. With ANSI standard ¼" cartridge tape for back-up.

It's up to 15% faster than an RL02, thanks to our non-interleaved data transfer mode.

800 Series is here now.

Maybe you're still waiting for Digital's Micro-11.[®] And waiting.

The higher capacity DSD 800 Winchester Series is available now. In quantities. And it's backed by the most intelligent service features in the industry.

So next time, take the guesswork out of buying a data storage system. With the DSD 800 Winchester Series. The best-selling RL02 alternative.

For more details, call the sales office in your area. Eastern Region Sales and Service: Norwood, MA, (617) 769-7620. Central Region Sales and Service: Dallas, TX, (214) 980-4884. Western Regional Sales: Santa Clara, CA (408) 727-3163.

The DEC-compatible DSD 800 Winchester Series offers you a choice of back-up: Tape or Floppy.

Pictured here, the 880 Winchester/Floppy. Shown above, the 890 Winchester/Tape.



DATA SYSTEMS DESIGN

INTERNATIONAL SALES: Australia 03/544 3444; Belgium and Luxembourg 02/720 9038; Canada 416/625 1907; Denmark 02/63 22 33; Finland 90/88 50 11; France 03/411 5454; Hong Kong and Peoples Republic of China 03/696231; Israel 52-52444; Italy 02/4047648; Japan, Osaka 06/323 1707, Tokyo 03/345 1411; Netherlands 020/02977-22456; New Zealand 04/693 008; Norway 02/78 94 60; Singapore, Malaysia, and Indonesia 449-4433; Spain 01/433 2412; Sweden 08/38 03 70; Switzerland 01/741 41 11; United Kingdom 7073/34774; West Germany and Austria 089/1204-0; Yugoslavia 61/263 261. *DEC and Micro-11 are registered trademarks of Digital Equipment Corporation.

A SECOND LOOK AT COMPUTER PIRACY

The case of Apple versus Franklin may give copyright protection to software, but the guidelines are not clear. The decision can be better understood in the context of a cultural collision between the technical and legal professions.

by Estella S. Gold

The appeals court decision—Apple versus Franklin—has received a lot of press coverage. Unfortunately, some of it was too superficial to be helpful. The editors of Computer Design feel that software protection is important enough to our readers for us to depart from our usual format. Therefore, we are running this in-depth article on the significance of the Apple decision.

On Aug 30, 1983, the United States Court of Appeals for the Third Circuit handed down a definitive decision that computer software, even in object code or ROM form, may be afforded copyright protection. This ruling reversed the trial court's denial of Apple Computer Inc's application for a preliminary injunction against Franklin Computer Corp (for simplicity called *Apple I*). The news shook the computer industry and its lawyers, offering legal remedies against piracy. As the court openly admitted, this was a case of "first impression." Franklin is now appealing.

Based upon this appellate decision (for simplicity called *Apple II*), the computer industry and the news media may rightfully expect that their legal counsel can now establish clear guidelines on how to adequately protect their products. Not so.

What the courts did not decide

On May 12, 1982, Apple sued Franklin for copyright infringement, patent infringement, unfair competition, and misappropriation due to

Estella S. Gold is president of Anti-Piracy Products, Inc, 302 North Washington St, Moorestown, NJ 08057. She is a member of the New Jersey and Pennsylvania bars, and is in private practice. She holds a BA in mathematics from Smith College and a JD from Rutgers University.

Franklin's manufacture and marketing of the Ace 100. Fourteen operating system programs are at issue, among them Applesoft and DOS 3.3. Apple's procedures in filing these programs with the U.S. Copyright Office were inconsistent—some were submitted in source-code form, some in object-code form, some on diskette, and some on ROMs. Franklin defended, asking the court to determine that each of the copyrights claimed is invalid, and counterclaiming that Apple attempted to monopolize its technology in violation of antitrust laws.

The *Apple I* case is limited to Apple's request for a preliminary injunction against Franklin. On Aug 2, 1982, Judge Clarence C. Newcomer in the District Court, for the Eastern District of Pennsylvania denied Apple's preliminary injunction request. *Apple II* is the appeal from that denial. *Apple II*, like *Apple I*, does not address patent infringement, unfair competition, misappropriation, or Franklin's antitrust claim. The focus of *Apple II* is the correctness of the district court's denial of the preliminary injunction. The reversal decision remanded the case to the lower court for further decision on the validity of Apple's procedure in obtaining the copyrights.

A preliminary injunction, commonly referred to as a temporary restraining order or TRO, is the court order requiring the supposedly offending party to stop the objectionable activity until an actual trial on the issue. Failure to obey could result in contempt.

The court's decision is usually made well in advance of the trial and the amount of evidence available upon which the judge bases a decision is often limited. Under these circumstances, parties to the lawsuit applying for the injunction must show the court that they have a reasonable probability of success at trial and that, without the injunction, they would suffer irreparable harm. The standards for granting preliminary injunction

are intentionally high in an effort to be fair to the party whose freedom will be restricted until the day of trial. For example, in a dispute over ownership of land, a preliminary injunction to stop the cutting of trees until the trial date would be a typical scenario.

Franklin admitted copying

Apple applied to the court for a preliminary injunction to restrain Franklin from using, copying, selling, or infringing upon Apple's copyrights on 14 programs. Apple presented evidence that the Ace 100 programs were virtually identical to the Apple programs except for the deletion of the Apple name and its copyright notice. In one program, the word "Applesoft" and the programmer's name still were embedded in the Franklin code. (One cannot help but marvel at how human foibles become valuable evidence at trials.)

Franklin witnesses testified that they had studied the feasibility of independently developing the programs and decided that the attempt was impractical. Franklin employees openly admitted copying. They outlined the technical difficulties of interfacing with the Apple software, which had a multitude of entry points. The court did not address this last testimony, and one cannot help but suspect that possibly only the programmers present understood the problem Franklin raised.

Given Franklin's admitted copying, the company's only defense to Apple's probable success at trial would be that the programs were not "copyrightable," or failed to meet the requirements of registration. For unexplained reasons, the *Apple I* court focused its discussions almost exclusively on the copyright of the software on ROMs, ignoring the source-code and object-code submissions.

Without question, based upon earlier cases, source code could be copyrighted. However, object code has been treated with some hesitation. When submitted to the U.S. Copyright Office in object form, the applicant receives a "letter of doubt" which reads in part:

"The Copyright Office generally requires the best representation of the authorship for which copyright is being claimed. Because copyright examiners are not skilled computer programmers, they have extreme difficulty in examining computer programs in other than source code format to determine whether the deposit contains copyrightable authorship. Deposit copies of works registered for copyright are available only for inspection in the Copyright Office by members of the public and may not be 'copied.'

... Where however, the applicant is unable or unwilling to deposit a printout in source format, we will proceed with registration under our 'rule of doubt' upon receipt of a letter from the applicant assuring us that the work as deposited contains copyrightable authorship."

This letter of doubt is not a refusal of copyright status. Although the letter would appear to be a refusal of enforceable copyright status, it actually leaves the applicant in limbo. The applicant may provide the requested letter of assurance but never know if those rights are enforceable until the applicant sues an infringer and receives a favorable court decision.

The programs on the ROM presented the most difficult problems to both the *Apple I and II* courts because the ROM is a physical device. Prior court decisions determined that videogame ROMs were copyrightable. Franklin argued that the Apple

"The first thing we do, let's kill all the lawyers"—King Henry VI

ROMs produced no humanly readable product and that the ROM chips are part of the electro-mechanical process of the computer. Such processes can sometimes be patented, but heretofore not copyrighted. The *Apple I* case did not decide that ROMs could not be copyrighted—the court simply expressed "doubt" regarding ROMs. Since Apple had to prove "likelihood of success at trial" to be awarded the preliminary injunction, the court's "doubt" meant certain defeat.

The communication barrier

Anyone reading the testimony, briefs of counsel, and court opinion cannot help but conclude that at last the lawyers have met their match when confronted with EDP's love of technical terms and jargon. But my comparison is an unfair one. Both lawyers and litigants know that "real time," "interface," and "software" are technical terms. Yet, how many of the EDP witnesses know that "expression," "concept," and "ideas" are technical terms of such difficulty in copyright law that even in current opinions, judges spend pages of explanation on each point?

The lawyer's use of ordinary language as "terms of art" may remind many frustrated clients and witnesses of a line from Shakespeare's *King Henry VI*: "The first thing we do, let's kill all the lawyers." For example, in *Apple I*, there was testimony from Apple's systems programmer describing an operating system that manages files: "It is a general sort of concept that many applications may require." In its brief, Franklin argued that "concepts" under Section 102(b) of the copyright law are excluded from protection. Section 102(b) reads as follows:

"In no case does copyright protection for an original work of authorship extend to any *idea*, procedure, process, system, method of operation, *concept*, principle or discovery . . ." (emphasis supplied).

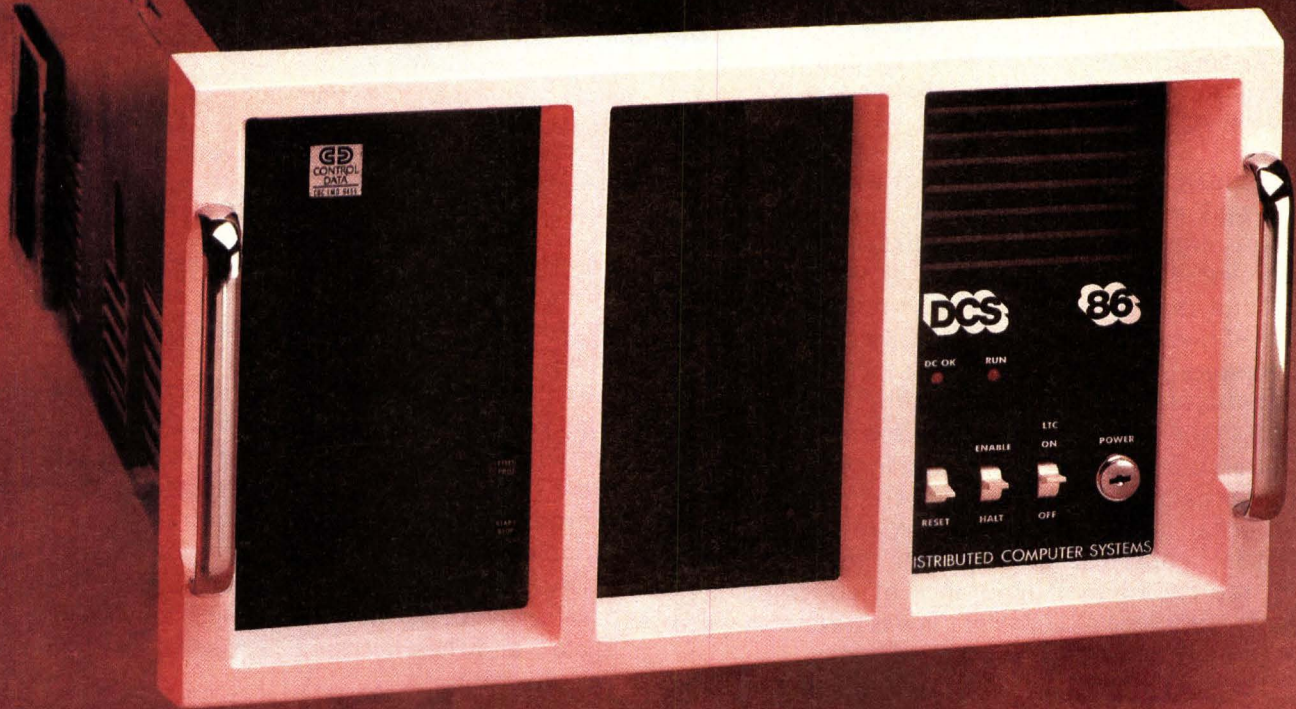

BORN TO BE ABUSED!

Raised in a harsh environment, our DCS/86 16-bit Multibus compatible computer system can cope with industrial reality.

Industrial Ruggedness

Designed for industrial applications, the DCS chassis is solid metal with no plastic, injection-molded parts. The front panel is an aluminum casting and our Multibus card cage is aluminum with a low-noise multi-layer backplane. Only the finest mechanical components are used to insure structural integrity in the most adverse conditions.

Reliability

Industrial grade preburned-in chips are used. Our system modules are subjected to dynamic burn-in at 55°C for forty-eight hours in our environmental chamber. As a fully matured unit, every DCS system is completely tested for a minimum of 5 days with extensive system diagnostics. At DCS, reliability is not a slogan, it is our commitment.

Unmatched Modularity

Our DCS systems are created to meet virtually any industrial application. They permit the user to mix and match operating systems, high level languages, interfaces, fixed and removable storage with a complete range of Multibus peripherals. Hardware configurations in our standard 19" rackmountable

chassis can contain fixed and removable hard disks in 5 1/4" and 8" sizes as well as standard or slim line floppies. Operating systems supported are CPM/86, MPM/86*, MS-DOS*, Concurrent CPM/86* and RMX-86*. "C", Fortran and Pascal are among the high level languages used. Whether your applications involve real-time data acquisition, multi-user software developments or data base management for factory automation, the DCS/86 family has a configuration to meet your budget.*

Support

Since 1979, DCS has been designing and manufacturing rugged industrial micro-computer systems for process/industrial control, data communications and software development. The DCS family has been abused in harsh environments the world over. DCS provides total systems support through our expanding network of direct regional sales/support centers in conjunction with our corporate customer support group.

For further information call: 617-890-8200 or write:

DCS Distributed Computer Systems
330 Bear Hill Road, Waltham, MA 02154

*Multibus and RMX trademarks of Intel
*CPM and MPM trademarks of Digital Research
*MS-DOS trademark of Microsoft

The court in *Apple II* then recognized and addressed the problem:

“The witnesses undoubtedly had the not uncommon difficulty of finding the precisely correct words of description in this field. It would be both unreasonable and arbitrary to consider the statements of non-lawyer witnesses without experience in using the statutory language as words of art to be binding admissions against Apple.”

Obviously, the programmer was using English.

Franklin now appeals on this point (only one of many arguments Franklin makes): “[The court] dismisses the testimony of Apple witnesses on the ground that the witnesses were not trained in the use of the technical language of Section 102(b). But how does [the court] know that fact? [the fact that the programmer was using English rather than statutory language] It is not in the record.” Following this argument to its extreme and logical conclusion, this programmer, in order to competently testify on behalf of Apple, would have to pass a literacy test in “copyright language” or otherwise profess on the record total ignorance of copyright laws. Such ignorance of copyright law is rare among programmers and EDP management today.

Franklin’s counsel cannot be faulted for acting like lawyers. Simply put, the appellate court in *Apple II* may reverse the earlier ruling only because of errors of law, and not change the facts as the *Apple I* court found them. The programmer’s use of the English word “concept” as compared with the word “concept” in copyright language is a question of fact and not subject matter for the appeal. This issue was but a minor point in the reversal of *Apple I*, but it illustrates communication difficulties between the EDP and legal communities.

What the *Apple II* court did decide

In reversing, the *Apple II* court makes absolutely clear that all forms of program expression in issue—source code, object code, and programs embedded in ROMs—are within the protection of the copyright laws. In addition, *Apple II* specifically decides that operating system programs are entitled to the same status as application programs for copyright protection.

The *Apple II* court found sufficient reason to rule that Apple had the requisite probability of success to satisfy that first criterion for the preliminary injunction. But what of the second—irreparable harm? The *Apple I* court addressed the question with but two sentences:

“It is also clear that Apple is better suited to withstand whatever injury it might sustain during litigation than is Franklin to withstand the effects of a preliminary injunction. While I am not prepared to find that the injunction sought by Apple would force Franklin

out of business, it would certainly have a devastating effect.”

This was the *Apple II* court’s response:

“Nor can we accept the district court’s explanation which stressed the ‘devastating effect’ of a preliminary injunction on Franklin’s business. If that were the correct standard, then a knowing infringer would be permitted to construct its business around its infringement, a result we cannot condone . . . (citations omitted) the size of the infringer should not be determinative of the copyright holder’s ability to get prompt judicial redress.”

These “moral” considerations aside, the *Apple II* court also ruled that a fair showing of copyright infringement carries with it a presumption of irreparable harm.

As the fictional Mr Dooley said, “An appeal is when ye ask wan court to show its contempt for another court.” One cannot help but wonder if the *Apple II* court’s outrage over the admitted piracy of programs costing over \$740,000 to develop, in conjunction with the trial judge’s sympathy for the underdog, has caused the court to decide more than the issues before it. Such decisions are called “dicta” and then need not necessarily be followed in future cases.

If the *Apple II* court has ruled definitively that software in source-, object- and ROM-storage forms are copyrightable, then why did they remand the case to the district court for a decision on Apple’s application for a preliminary injunction on the Copyright Office’s rule of doubt? After *Apple II*, the rule of doubt should no longer exist. The appellate court has decided object code is copyrightable and such a decision is binding. Sending the case back to the lower court on the rule of doubt causes confusion because the rule of doubt is based on the idea that object code may or may not be copyrightable. With this ambiguity, it is likely that the *Apple II* decision, hailed by the industry, will be before future courts for interpretation. Apple faces other issues on remand to the district court, such as proper notice and misuse of the copyright, which must be overcome before a preliminary injunction will be issued.

Antipiracy solutions

Will Rogers once said, “The minute you read something you can’t understand, you can almost be sure it was drawn up by a lawyer.” As a lawyer, I am commonly faced with the difficulty of explaining what is copyrightable material. “Expression” is protectable. “Ideas,” “concepts,” and “methods” are not. The explanations inevitably leave clients confused and lawyers must often use analogies, (often humorous) in an effort to explain. For example, the idea of a chocolate cake is not protected. People who follow recipes are not

We gave solderless breadboarding a new name.

Proto-Board® breadboards, by Global Specialties. The leading name in solderless breadboarding.

You find them wherever electronics is important. From labs to production lines to classrooms to home workshop benches. Their name, synonymous with solderless breadboarding. And for good reason.

Proto-Board breadboards introduced engineers, technicians and hobbyists to a new way

of designing and building electronic circuits: as fast as they can think. Testing, modifying and expanding as quickly as new thoughts occur. Saving precious time and money by freeing creativity from manual labor.

Global Proto-Board products are arrays of solderless sockets and bus strips that emulate PC board layouts

while permitting instant insertion and removal of components from the largest DIP to the smallest discretes. With a rugged construction built to provide positive connections and withstand day-in, day-out professional use—even as test fixtures. And mounted on sturdy metal backplanes, for extended high-frequency use and extra durability.

Their value and versatility are why so many professionals and hobbyists are "Proto-Board"-ing. And why you should be, too.

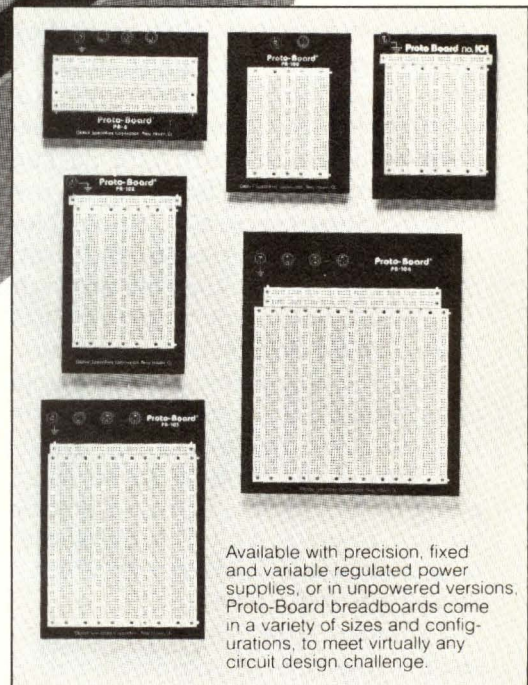
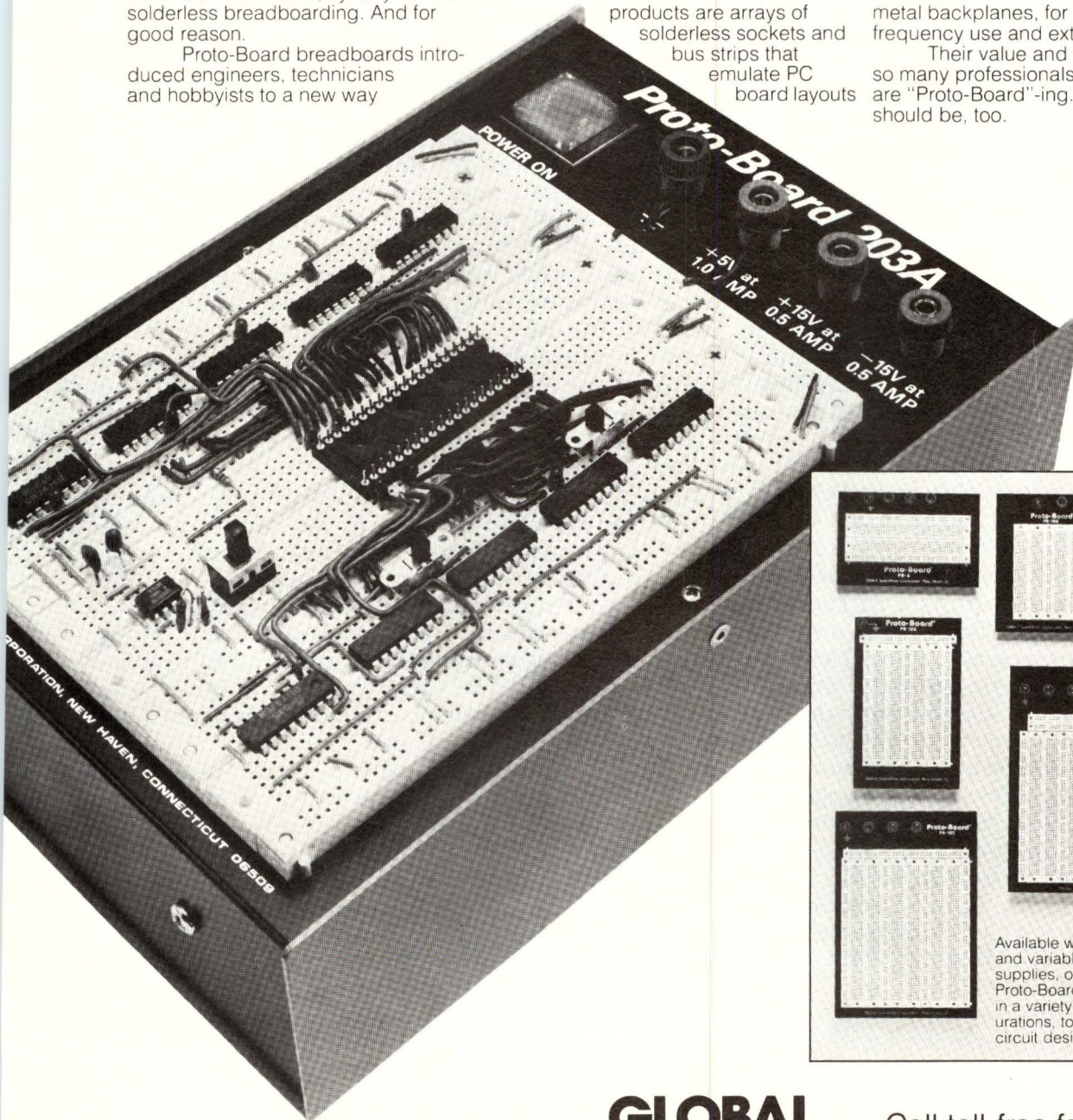

Available with precision, fixed and variable regulated power supplies, or in unpowered versions. Proto-Board breadboards come in a variety of sizes and configurations, to meet virtually any circuit design challenge.

70 Fulton Terr., New Haven, CT 06509 (203) 624-3103, TWX 710-465-1227
 OTHER OFFICES: San Francisco (415) 421-8872, TWX 910-372-7992
 Europe: Phone Saffron-Walden 0799-21682, TLX 817477
 Canada: Len Finkler Ltd., Downsview, Ontario

**GLOBAL
 SPECIALTIES
 CORPORATION**

Call toll-free for details
1-800-243-6077
 During business hours

© Copyright 1981 Global Specialties Corporation.

infringers. They may even sell the resulting cake without obligation to the recipe writer. But, they may not copy or sell the recipe.

These simple explanations assist the public in understanding copyright protection. Nevertheless, the difficulty remains in fitting the expanding complexity of computer technology into the restrictive girdle of an existing legal framework.

Copyright offers many advantages. It is easy and inexpensive to obtain—only requiring notice of copyright and registration with the U.S. Copyright Office. Once obtained, the copyright holder has exclusive rights to the work including enhancements and corrections incorporated in new versions of the software. Copyright duration is remarkable: the author's life plus 50 years, or, if the program is a "work made for hire," 75 years from first publication or 100 years from creation, whichever is shorter.

The copyright law is grounded in the U.S. Constitution and will be enforced nationwide against infringers. An infringement suit requires registration with the U.S. Copyright Office. Therefore, a "letter of doubt" on registration becomes critical in an infringement suit. If the copyright holder is successful in an infringement suit, recovery may include money damages for lost profits, counsel fees, court orders to prevent the making of additional copies, and court orders to seize and destroy illegal copies.

Detection of infringers is a problem plaguing the computer industry. On this issue the law provides no assistance. Copyright notices embedded in coding, and devices such as useless entry points deliberately inserted, assist in the courtroom to show intentional infringement. Rapid advances throughout the industry in the development of both hardware and software packages to prevent copying or to make illegal copies useless may provide the most practical solution. Nevertheless, the enormous cost of software and firmware development, as opposed to the high profitability of the industry, provides tremendous financial incentive to pirates intent on breaking codes and protections.

Since the processing time for patent protection is approximately three years, it is not worth addressing this protective method in any detail for software. Not only is the product to be patented probably going to be obsolete before protected, but patents do not tolerate with flexibility the constant enhancements and updates for which the computer industry is well known.

Although little has been written about trade secret protection in comparison to copyright and patents, it is probably the most widely used legal protection for software. When firms opt for trade secret protection, they take a course very different from that of the copyright applicant. Both patent and copyright laws are premised upon public disclosure, requiring registration in Washington. The theory is that publication of a new development

will provide the foundation for further advances in the industry. Until the *Apple II* case, the administrative copyright office and courts have opposed the deposit of coding that cannot be readily deciphered.

Enforcing trade secret protection

In contrast to copyrights and patents, the essential element in trade secret protection is secrecy. Legal secrecy in mass marketed software is hard to achieve, requiring aggressive procedures and assistance of counsel. Affirmative steps must be taken both in-house and in distribution to prevent dissemination of software contents. Contracts and marketing procedures must be planned carefully to maintain trade secret status, such as the use of licensing rather than sales agreements. A sale may be considered a loss of ownership rights that leaves the originator with no claim of secrecy. Consultation with legal counsel is essential to establish the appropriate steps to take. Other possible steps include prohibitions on copying for other than backup purposes with the customer, nondisclosure agreements, limitation of use to a single CPU, and restrictions on processing of third party data.

The deposit of object code and ROMs (by nature indecipherable to layman and lawyer) is an attempt to preserve both copyright protection and trade secret protection simultaneously. The courts have not yet fully resolved whether such deposit destroys trade secret status.

Legal enforcement will depend upon detection and the effort expended by the software producer in adequately following the legal guidelines. Legal remedies for trade secret infringement vary from state to state, unlike the copyright and patent laws.

In conclusion, it is apparent that the legal system is slowly addressing the problems raised by a new technology. The court decision of *Apple II* has brought to the computer industry new hope of legal protection against piracy.

The growth of computer literacy among the public will surely filter upward from schoolchildren to lawyers and judges. However, the ability of the legal system to explain in simple terms the laws of copyright, patent, and trade secret to the public is sorely lacking. Surely the English/copyright language problem for witnesses in *Apple I* and *II* will recur. Nevertheless, the first steps have now been taken to ensure that the innovators in the computer industry will more adequately profit by their endeavors.

Please rate the value of this article to you by circling the appropriate number in the "Editorial Score Box" on the Inquiry Card.

High 707

Average 708

Low 709

You're challenging the
limits of 5¼" drives.
And so are we.



Introducing the 5¼" high-density Maxell.

Tomorrow, our technology could help turn your theory into reality.

Where will new drive capabilities come from? Your vision. And our ability to envision the disks they demand.

When a new high-density 5¼" flexible drive went on the drawing board at YE Data, we went to work on a disk that matched its unprecedented 2,000,000 byte capacity. Compressing our oxide layer to a mere one micron, we achieved a 15,000 BPI recording density at 600 oversted resolution. And made a remarkable theory a reality.

What's next? You tell us. In the meantime, we'll be making 8", 5¼" and micro floppy disks that lead the industry in error-free performance and durability. Disks made to specifications so exacting, the only standard is our own. The Gold Standard.

maxell®
IT'S WORTH IT.



Maxell Corporation of America, 60 Oxford Drive, Moonachie, N.J. 07074 201-440-8020

CIRCLE 66

“We need a logic analyzer for all these problems... a real workhorse.”

SOFTWARE

- Execution time requirements
- 80186 and Z80 support
- Program flow and data flow tracking

HARDWARE

- High speed bus logic
- Control signal noise
- Intermittents

INTEGRATION

- Interprocessor communications
- Peripheral integration
- Hardware/software interface

GENERAL

- Test documentation
- Manufacturing and service procedures
- Short learning curve

MURPHY'S LAW



Tek's 1240.

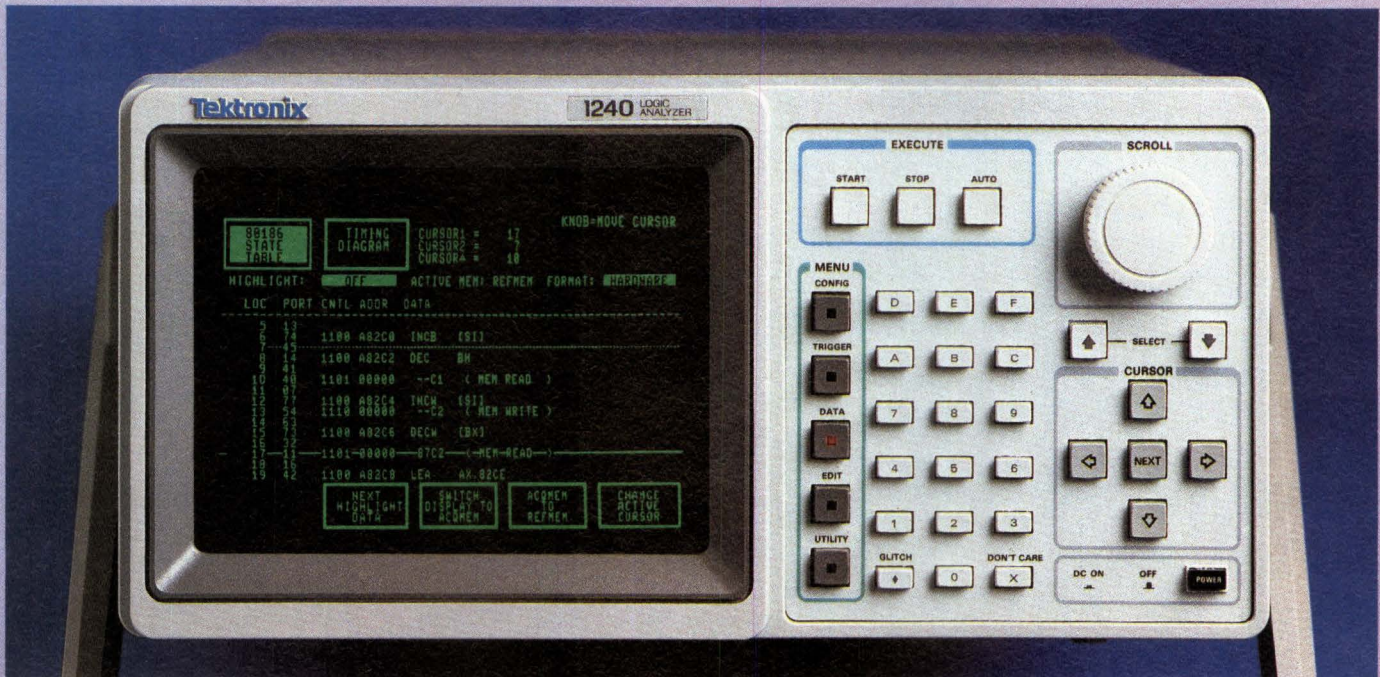

Versatility is its middle name.

Hardware analysis. Software analysis. Integration. The 1240 lets you master them all, thanks to features like glitch detection and triggering. Autorun. 50 MHz synchronous, 100 MHz asynchronous data acquisition. 72 channels. Performance analysis. A powerful trigger and qualifier. The only dual timebase in the industry. Plus support for the 80186, 68000, F9450 and 15 other chips.



Acquisition Cards, ROM Packs and COMM Packs for the 1240.

We know Murphy can strike.

We built the 1240 to make those unexpected problems a little easier to handle. It's modular, so you can add capability when you need it. Take a look at your choices:

Acquisition Cards	<ul style="list-style-type: none"> • 9 channels, 100MHz • 18 channels, 50 MHz
ROM Packs	<ul style="list-style-type: none"> • Microprocessor disassembly (18 processors) • Performance Analysis • Master/Slave Support • Line Printer Support • Mass Storage • Extended Diagnostics
COMM Packs	<ul style="list-style-type: none"> • RS-232 • GPIB • Parallel Printer Port

Talk about easy.

Easy to learn. Easy to use with smooth scrolling and touch-sensitive, menu-driven displays. Plus multiple levels of operation,

so you can start with the basics and add progressively more advanced features.

Time to talk.

When your team needs logic analyzers to solve many problems, and you want to get your money's worth, call your Tektronix engineer and describe your applications. We'll help you put together a 1240 solution for your team.

TEKTRONIX LOGIC ANALYZERS

Talk to us.

For further information, contact:

U.S.A., Asia, Australia, Central & South America,
Japan Tektronix, Inc., P.O. Box 1700, Beaverton, OR 97075.
For additional literature, or the address and phone number of the Tektronix Sales Office nearest you, contact: Phone: 800/547-1512, Oregon only 800/452-1877, TWX: 910-467-8708, TLX: 15-1754, Cable: TEKTRONIX
Europe, Africa, Middle East Tektronix Europe B.V. European Headquarters, Postbox 827, 1180 AV Amstelveen, The Netherlands, Phone: (20) 471146, Telex: 18312-18328
Canada, Tektronix Canada Inc., P.O. Box 6500, Barrie, Ontario L4M 4V3, Phone: 705/737-2700

The world's fastest 16K are available now

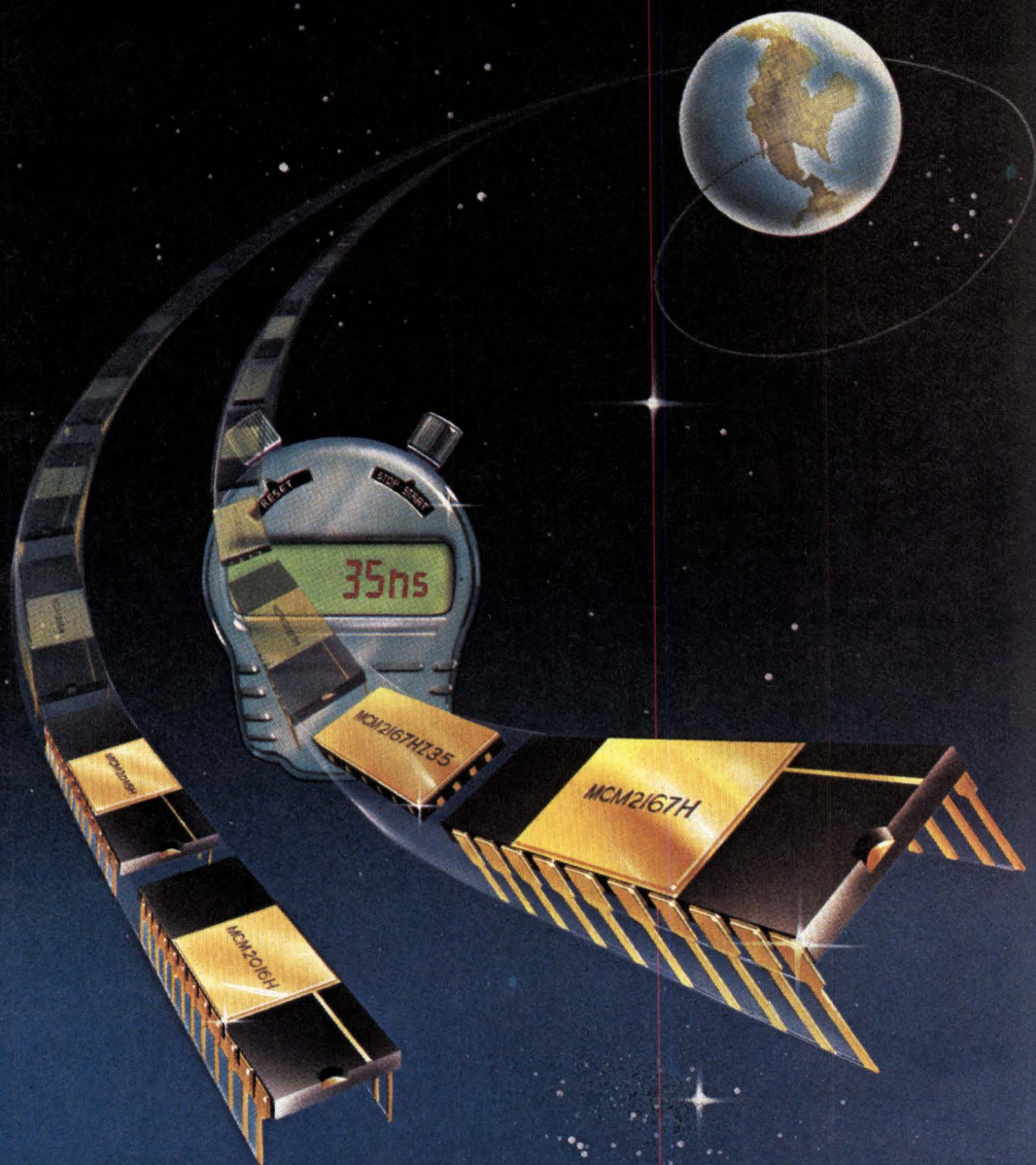

MOS static RAMs from Motorola.

MOS system memory speeds close in on logic.

Now you can use Motorola's MCM2167H and MCM2016H to bring your MOS cache and very high-speed buffer memories closer to logic speeds.

At 35 ns, the MCM2167H is the fastest 16K MOS static RAM in the world, and our MCM2016H is a match for any 2K x 8 at 45 ns.

We're ramping up production quantities to these and slightly less exotic speeds, and these fast static RAMs offer much more than world class speeds.

HMOS II process adds reliability.

The silicon-gate HMOS II process used in their fabrication contributes substantially to high performance and reliability. We've developed techniques for elimination of soft errors and for increasing density. Development and years of volume production of our leadership 64K RAM have given us the experience in advanced technologies that enhances the ease of manufacture, producibility and performance of the new generation MCM2167H and MCM2016H statics.

Innovative design concepts permit fully static RAMs, giving the power savings usually associated with clocked memories. Space efficient packaging options are standard, too.

State-of-the-art packages save board space.

The industry is accustomed to standard 24- and 20-pin packaging, and we've made no exception here. The MCM2167H is available in the 20-pin, 300-mil dual in-line, but you can also get it in a super space-efficient Leadless Chip Carrier. A 24-pin, 600-mil package is the familiar standard for the 2K x 8, but our MCM2016H is also available in a skinny, 300-mil space saver. Substantial board space is conserved with both of these state-of-the-art packages.

Absolutely no clocks or timing strobes.

As stated, these are fully static memories. No clocks or timing strobes are used. Power down is controlled by

the Chip Enable, with the RAM in the low-power standby mode as long as Chip Enable stays high. Standby power dissipation for both the MCM2167H and MCM2016H is 20mA, and in the active mode it's 120 mA for each.

You're probably, as most designers are, always looking for better performance and reliability. Justifiably, Motorola satisfies this quest for superiority. If speed is what you're after in a reliable, space-saving 16K static RAM, you'll find more of what you're looking for at Motorola and Motorola's authorized distributors.

And for the times your requirements also include ultra low-power statics, we call your attention to our 4K and

16K CMOS fully static RAMs. They're on the fast side, too.

Motorola's fast static RAMs can give your systems the competitive edge.

Get more complete technical information by sending the coupon or writing to Motorola Semiconductor Products Inc., P.O. Box 20912, Phoenix, Az 85036. For fast, direct assistance, contact your Motorola sales office or authorized distributor.

Motorola Fast Static RAMs

ORGANIZATION	ACCESS TIME (MAX)	PART NO.	PACKAGE TYPE	OPERATING CURRENT (MAX)	STANDBY CURRENT (MAX)	TECHNOLOGY
16K x 1	35,45.55	MCM2167HL	300 Mil Ceramic DIP	120 mA	20 mA	HMOS
	35,45.55	MCM2167HZ	Leadless Chip Carrier	120 mA	20 mA	HMOS
	35,45.55	MCM2167HP	300 Mil Plastic DIP	120 mA	20 mA	HMOS
2K x 8	45.55,70	MCM2016HY	300 Mil Ceramic DIP	120 mA	20 mA	HMOS
	45.55,70	MCM2016HL	600 Mil Ceramic DIP	120 mA	20 mA	HMOS
	45.55,70	MCM2016HP	600 Mil Plastic DIP	120 mA	20 mA	HMOS
2K x 8	120,150,200	MCM6116P	600 Mil Plastic DIP	55 mA	2000 uA	CMOS
	120,150,200	MCM61L16P	600 Mil Plastic DIP	55 mA	100 uA	CMOS
4K x 1	55,70	MCM6147P	300 Mil Plastic DIP	35 mA	800 uA	CMOS
	55,70	MCM61L47P	300 Mil Plastic DIP	35 mA	100 uA	CMOS

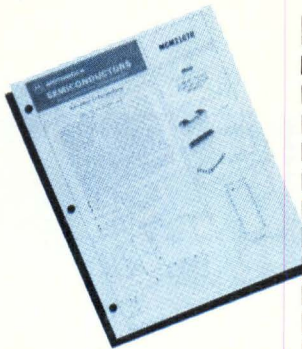

MOTOROLA INC.

TO: Motorola Semiconductor Products Inc., P.O. Box 20912, Phoenix, AZ 85036.

Please send me more information on Static Rams

A MCM2167H B MCM2016H C CMOS

157CD010083

Name _____

Title _____

Company _____

Address _____

Call Me. Phone: _____

WHEN WE INTRODUCED OUR PEOPLE HAD

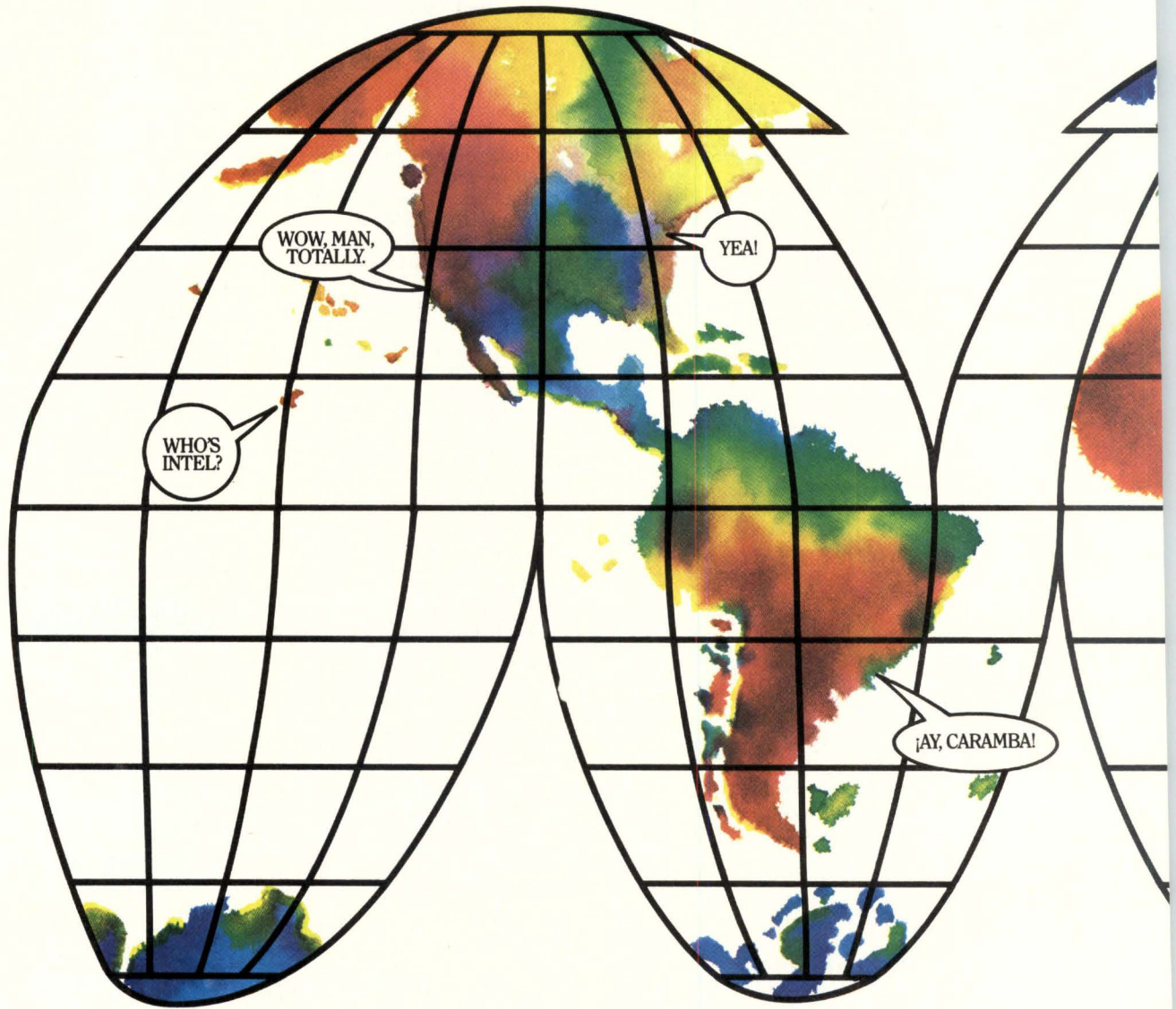

Not everyone is happy about it. For instance, our new 286/310 multi-user, multi-tasking OEM supermicro is going to make guys who push minis awfully uncomfortable.

You see, it's based on our advanced iAPX 286 microprocessor, the most powerful 16-bit processor in the world. To which we've added our 80287 math co-processor as a, shall we say, turbocharger?

That little bit of technological tinkering makes it a very fast supermicro. Faster than a VAX*

11/750. In fact, according to independent benchmarks, the 286/310 is the world's fastest Xenix* supermicro.

It doesn't do too badly in iRMX™ real time OEM applications, either (3x the performance of any comparably-priced system.)

The kicker is the 310 costs less than \$10,000. And that's list, quantity one. OEM quantities are so much less expensive it's embarrassing.

But before you start thinking about all the money you can make with the 310, let us tell you

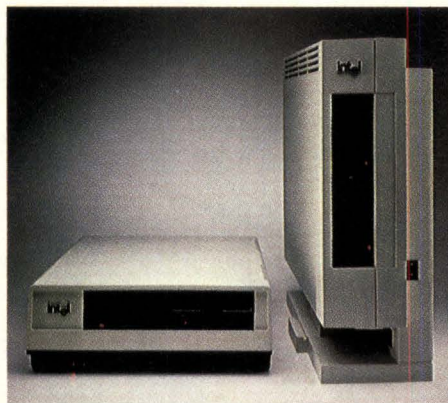

286/310 Supermicro System

NEW SUPERMICRO SYSTEM, LITTLE TO SAY.

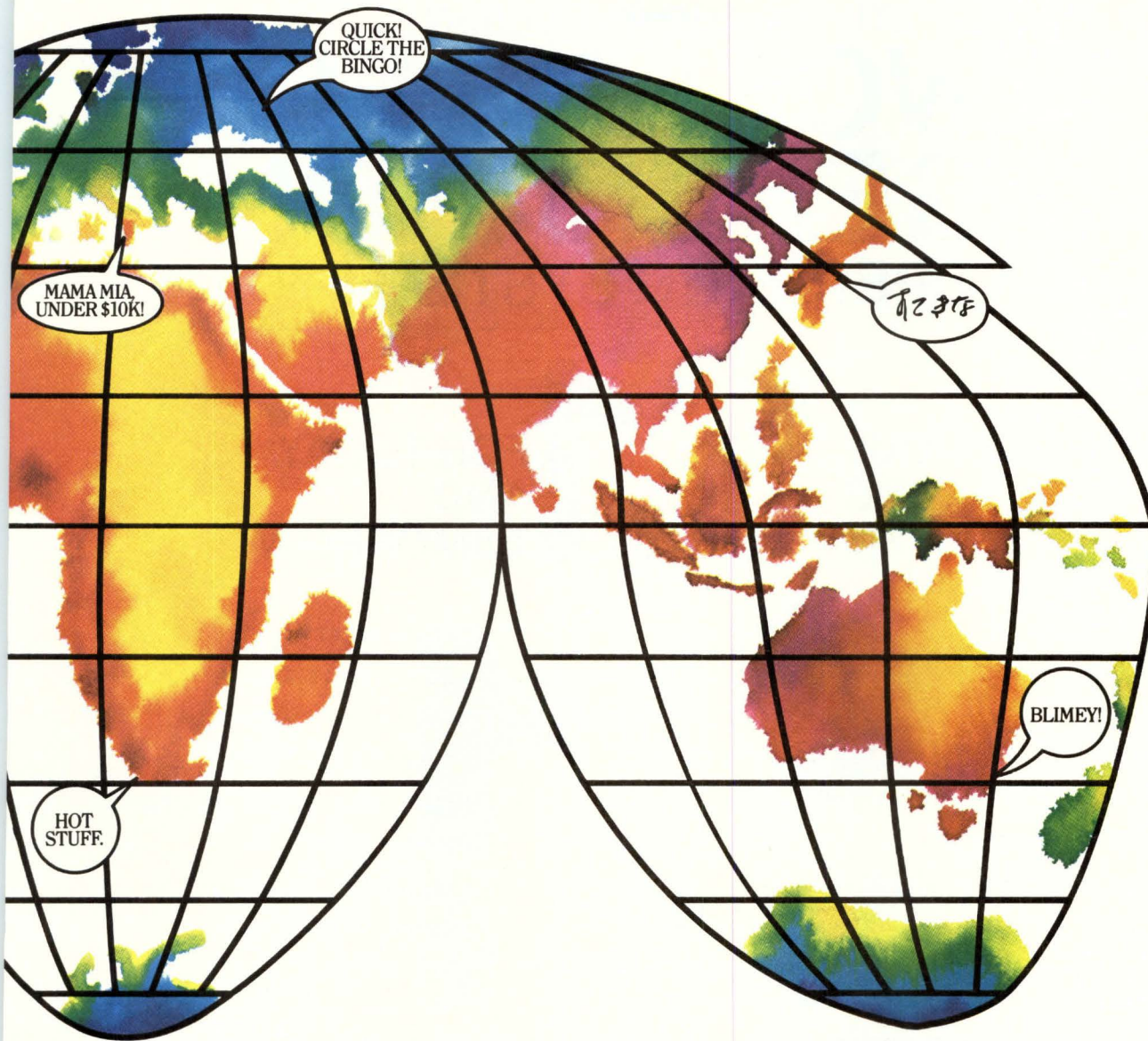

a little about how easy it'll be.

Like all Intel systems, the 286/310 is built on standards.

The MULTIBUS* architecture. The iRMX real time operating system. Ethernet* networks and protocols. And the Xenix* operating system. Not to mention the world's most-written-for microprocessor architecture, the 8086 family.

All of which makes the 310 a very open system. Open to all kinds of OEM configurations. And enhancements like integrated software, interactive speech, graphics, networking, even software-in-silicon. And that means it's also open to new markets and new opportunities.

You'll also be able to find service and support for you and your customers' systems from more than 80 service centers worldwide.

Which is what you'd expect from a company with more than a billion dollars in sales.

So get the information you need on the world's fastest supermicro. Including a series of independent benchmarks. Call toll-free, (800) 538-1876. In California, (800) 672-1833. Or write Intel, Lit. Dept. S8, 3065 Bowers Avenue, Santa Clara, CA 95051.

Enough said.

intel® delivers solutions

*Ethernet is a registered trademark of Xerox Corp. *Xenix is a fully licensed version of UNIX** and a registered trademark of Microsoft, Inc. *VAX is a registered trademark of Digital Equipment Corporation. **UNIX is a registered trademark of Bell Laboratories. © 1983 Intel Corporation.

UNIX[®] IS A DINOSAUR CP/M[®] & MS-DOS[™] ARE TOYS

MULTI SOLUTIONS PRESENTS

THE WORLD'S FIRST 4th GENERATION OPERATING SYSTEM

A SERIOUS
OPERATING
SYSTEM

S1[™]

FOR TODAY
AND
TOMORROW

- PORTABLE
- MODULAR
- MULTIUSER
- MULTITASKING
- MULTI PROCESSING
- PARALLEL PROCESSING
- 64 CHARACTER NAMES
- COMMAND PROCESSOR
- REAL TIME
- NETWORKING
- DISTRIBUTED PROCESSING
- HIERARCHICAL DIRECTORIES
- KEYED FILES
- ISAM
- VSAM
- B-tree
- RECORD LOCKING
- UNIX SOURCE COMPATIBLE
- WINDOWING
- BIT MAPPED DISPLAYS
- FULL SCREEN MANAGEMENT
- FULL SCREEN EDITING
- FULL MEMORY MANAGEMENT
- VIRTUAL MEMORY
- SEMAPHORES & LOCKS
- EXTENSIVE UTILITIES
- AND MUCH, MUCH, MORE

S1 IS THE ONLY OPERATING SYSTEM WORTHY OF THE TITLE:
“THE NEXT WORLD STANDARD.”

ONLY S1 DOES IT ALL.

**NO OTHER OPERATING SYSTEM
COMES CLOSE. CUTS DEVELOPMENT
TIME FROM MAN YEARS TO MAN MONTHS.**

Please send for our **FREE S1 Book** or Call **609-695-1337**

IN TIME, ONLY THE BEST WILL SURVIVE: S1



Multi Solutions, Inc.
660 Whitehead Road
Lawrenceville, NJ 08648
609/695-1337

*Reg. Trademarks: CP/M of Digital Research; Unix of Bell Laboratories Trademarks: MS-DOS of Microsoft, Inc.

LANGUAGE-BASED ARCHITECTURE EASES SYSTEM DESIGN—III

Occam channels are implemented on a multiprocessor Z80 system, using the only computer language designed for multiple processors and true parallel processing.

by B. Jane Curry

This is the third in a series of articles on the Occam language. (See Computer Design, Nov 1983, pp 107-115 for Part I, and Dec 1983, pp 109-120 for Part II.)

Occam was designed to provide a simple solution to concurrent processing problems. The language provides sequential and parallel constructs directly, thus removing the need for software to sequentially handle parallelism. Although Occam can be run on a single processor, with concurrency managed by calls to a multitasking runtime system, the obvious use for the language is in a multiprocessor environment where true concurrency can be shared between several processing elements. Occam embraces concepts in programming beyond conventional languages. Moreover, its instruction set is very small, compact, and system oriented.

An Occam program consists of one or more processes joined by constructors. There are three basic types of Occam constructors: sequential (SEQ), where program elements are executed in sequence; parallel (PAR), where program elements are executed in parallel; and alternative (ALT), in which one program element is selected from a set. The conventional 'WHILE' statement achieves repetitive execution of a process. Communications between processes take place through a channel, the fundamental communication element in Occam.

Besides channels and processes, arithmetic, Boolean, relational, or bit operation expressions are the remaining fundamentals of Occam. The

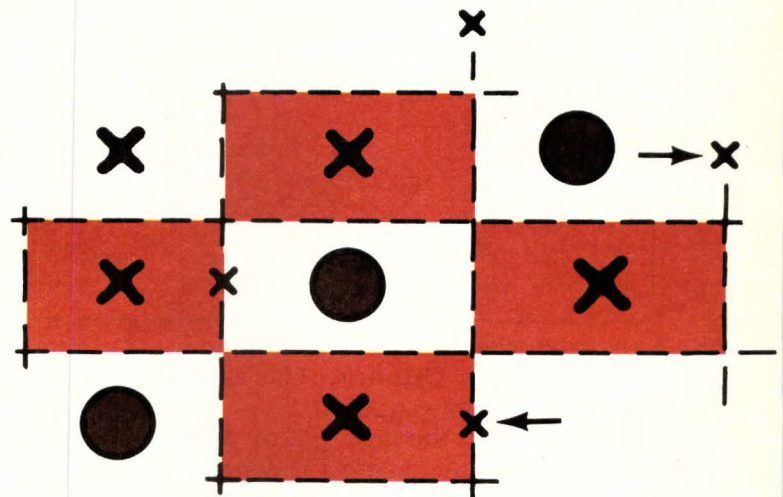

basic data type in an Occam program is the 'word,' which can be used to represent numbers, characters, or Boolean values. Variables must be declared before use, preceded by the reserved word VAR. Similarly, CHAN precedes declared channels.

Occam's simplicity is demonstrated by its three fundamental processes: assignment (variable := expression); output (channel ! expression); and input (channel ? variable). All other processes are built from these three basic elements with the constructors SEQ, PAR, and ALT, and the arithmetic and repetitive functions. Contiguous lines of code, indented at the same level, share the same context. Each concurrent process has its own variables, which cannot be shared by any other process unless passed by way of a channel. Thus, programs can be devised in a modular fashion, with a well-defined interface between separate processes.

The channel, a one-way communication medium between two concurrent processes, is key to Occam's concurrency power. Communication is synchronized such that output cannot take place unless the channel is free, and input cannot take place unless the channel is supplying a value. Thus, both the input and output processes must be ready before transfer

B. Jane Curry is microprocessor development officer at Chelsea College, University of London, Pulton Place, London SW6 5P, England. She holds a BS in computer science from the University of Reading.

```

CHAN in,procin,procout,out           [declare channels]
PAR
  WHILE TRUE                          [continuously]
    VAR x:                             [local variable x]
    SEQ                                 [INPUT PROCESS]
      in ? x                           [input from in to variable x]
    ALT
      x < 0:                           [if value negative]
        procin ! -x                    [then output -x to procin]
      x >= 0:                          [else]
        procin ! x                    [output x to channel procin]
  WHILE TRUE                          [MEANWHILE, continuously]
    VAR X:                             [a different local variable]
    SEQ                                 [ARITHMETIC PROCESS]
      procin ? x                       [input from procin to x]
      x:=x+x                          [double x]
      procout ! x                     [output x to channel procout]
  WHILE TRUE                          [MEANWHILE, continuously]
    VAR x:                             [another local variable]
    SEQ                                 [OUTPUT PROCESS]
      procout ? x                     [input from procout to x]
      out ! x                         [output x to channel out]

```

Fig 1 This simple Occam program demonstrates the language's basic constructs. Its three-process system consists of an input process, an arithmetic process, and an output process. All three processes can run in parallel while data is available.

can take place. There is no implicit buffering associated with channels. The channel operators are input (?) and output(!).

For the user, the principle of the channel is the same whether the channel is connecting processes on one or many processors, even though the implementation obviously differs.

A simple Occam program (Fig 1) demonstrates most of the language's basic concepts. The degree of obtainable parallelism is diagrammed in Fig 2. In the most efficient situation, all three processes run simultaneously: the input process accepts data from the in channel, the arithmetic process performs calculations, and the output process sends data to the out channel.

Occam is available on the VAX and 8086. Inmos Transputer and 68000 versions are being developed. While an evaluation kit is available to run under the University of California at San Diego (UCSD) p-System, it is a single-processor compiler and thus does not fully exploit Occam's potential. To demonstrate further the principles of processes and channels, a dual-processor system has been constructed based on the Z80 CPU (Fig 3). Each system is independent, but the two can be connected via the parallel interfaces (PIAs) using a ribbon cable.

In the manner of channels, both halves of the PIA are used as single-direction communication links. Thus, the lines PA0 through PA7 are input lines, and PB0 through PB7 are output lines. A full

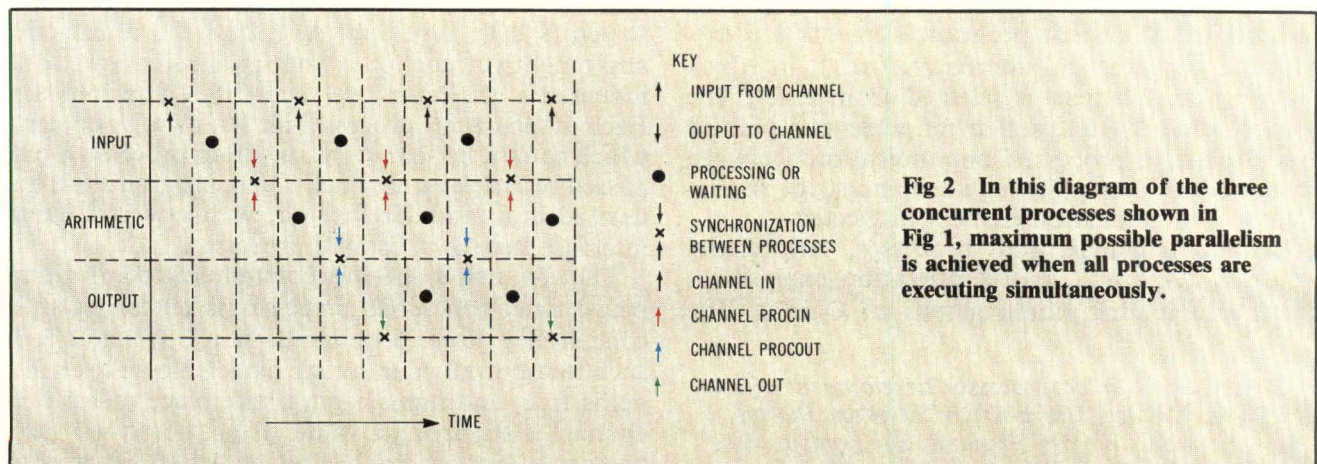

Fig 2 In this diagram of the three concurrent processes shown in Fig 1, maximum possible parallelism is achieved when all processes are executing simultaneously.

NEW 10ns DEVELOPMENT STATION INCLUDES 29116 EMULATOR 2910 EMULATOR



STEP ENGINEERING, The Company for High Speed Processor Development Support, presents the new STEP-27. STEP-27 is the fastest, most powerful development station available today. Consider STEP-27 features;

- **10ns** Writable Control Store (WCS) RAM
- **29116** Real Time Emulator
- Data Driven **Disassembly**
- **Symbolic Debug**
- **Unlimited** WCS per Station
16 to 512 Bits wide per WCS
up to 64K Deep per WCS
- **20MHZ** Trace with **16 level** triggering
- Microprogramming Support for **Any** Processor
- **Full Software Support** (Both Local and Remote Host)

A STEP Sales Engineer is located near you. For more STEP-27 information mail this coupon or **CALL STEP (408) 733-7837 TWX 910-339-9506**

STEP ENGINEERING

757 North Pastoria Avenue
P.O. Box 61166
Sunnyvale, California 94088

- I want more information about STEP-27
 I need to schedule a STEP-27 Demo ASAP

Name _____
Title _____
Company _____ M.S. _____
Street _____
City _____ State _____ Zip _____
Phone _____

STEP ENGINEERING

High Speed Processor Development Support

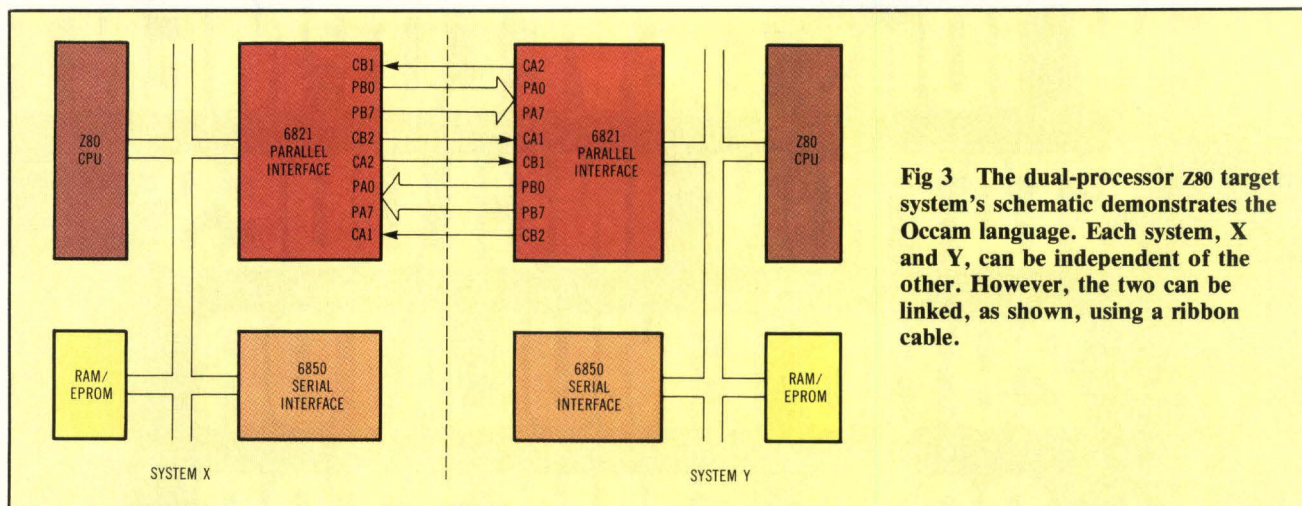

Fig 3 The dual-processor Z80 target system's schematic demonstrates the Occam language. Each system, X and Y, can be independent of the other. However, the two can be linked, as shown, using a ribbon cable.

hardware handshake is established between the two PIAs using the interrupt control lines CA1, CB1, CA2, and CB2. These lines can be programmed to act such that the falling edges of CA1 and CB1 set interrupt flags within the PIA and initiate a hardware interrupt. CA2 is driven low immediately following a read from the A data register (data input) and is returned to the high state on the rising edge of CA1. Similarly, CB2 is driven low following a write to the B data register (data output) and is restored to its high state on the rising edge of CB1.

Hardware/software implementation

Occam's channel concept demands that communication along the channel be synchronized so that data transfer will not take place until both processes involved are ready. This situation can be paralleled in the hardware using the PIA handshake lines, as described above, and a very small amount of Z80 code.

When a byte is written to a PIA, its CB2 line is driven low. This drives the CA1 line on the receiving PIA low and causes an interrupt. When this interrupt is processed, the receiving PIA executes a read

instruction, thereby sending its CA2 line low. This drives the transmitting PIA's CB1 line low, causing an interrupt. This interrupt restores the transmitter's CB2 line to its high state and signifies that the byte has been received and read at the other end of the channel. Fig 4 shows the timing diagram for this procedure. To complement the hardware, the software in Fig 5 is implemented to complete channel synchronization.

The interrupt service routine tests both halves of the PIA. If a character is present it is read and stored; if the interrupt is an output acknowledgment, a flag (OUTFLG) is reset to signify that the channel is no longer in use. The PIA output routine operates on a sense status basis, which tests OUTFLG until it is zero. When this condition is true, output takes place and OUTFLG is set to one, thus preventing further output until an acknowledgment is received from the other end. To avoid discrepancies, the flag setting must be made an indivisible operation with the output instruction.

As a result of the interrupt strategy, a process cannot receive input from a channel unless the interrupt service routine has received a byte.

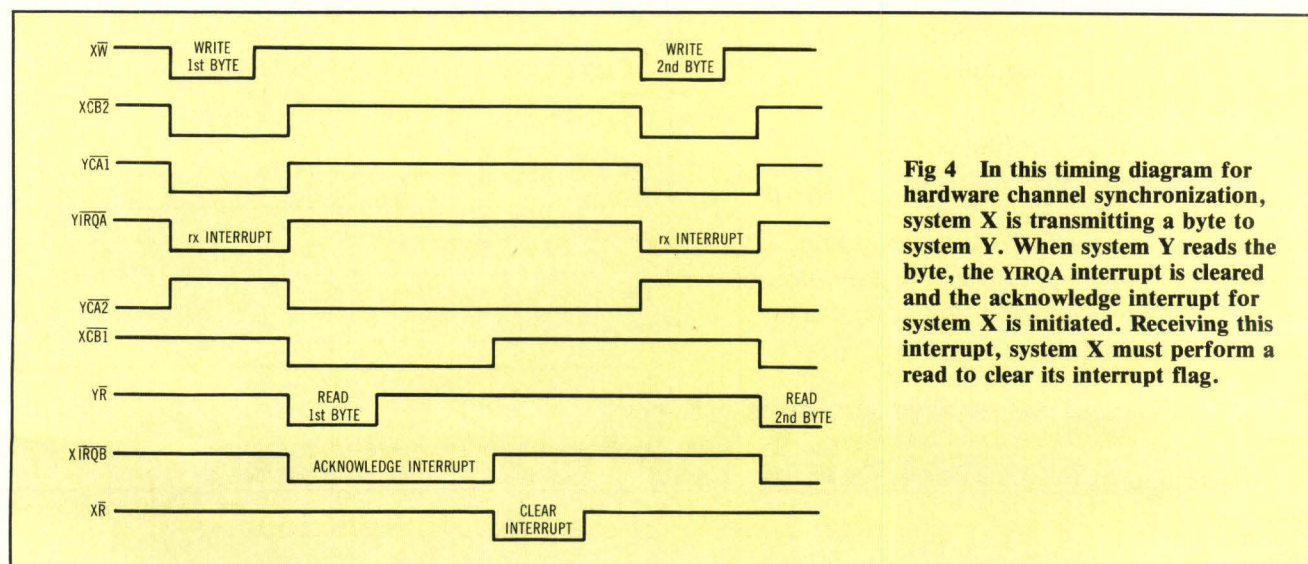

Fig 4 In this timing diagram for hardware channel synchronization, system X is transmitting a byte to system Y. When system Y reads the byte, the yIRQA interrupt is cleared and the acknowledge interrupt for system X is initiated. Receiving this interrupt, system X must perform a read to clear its interrupt flag.

Will Fujitsu's SCSI INTERFACE Please Stand Up?

For some time now, the disk drive industry has talked about the SCSI Interface. But all this talk has resulted in very little action. Until now. Today a leader in the SMD market is offering their OEM customers the

option of the SCSI Interface. That leader is Fujitsu America Inc.

SCSI, the ANSI-approved small computer systems interface, is a byte wide intelligent interface designed for host computer systems and peripheral units and can transfer data at up to 2MB/s. The computer and peripherals are inter-

connected on an eight port matrix bus, which enables any port to initiate communication to any of the other seven ports.

Fujitsu America now offers the state-of-the art SCSI interface option on the high performance 8" M2312 drive which has a capacity of 84 MB and an average positioning time of 20ms. Previously this drive was only available with an SMD interface.

A significant advantage of the SCSI interface is that it reduces the cost of interconnecting the drive to a computer. The integral SCSI controller replaces the need for an SMD controller. The only other requirement is a low cost host adapter.

Fujitsu America is committed to keeping you on the leading edge of disk drive technology. So whether you stand up for SCSI or for SMD, you can always count on Fujitsu... for innovation, for technical leadership, and above all for enduring quality.

For more information contact the Fujitsu America Sales Office nearest you. Northwest: (408) 988-8100, East Coast: (617) 229-6310, Southwest: (714) 558-8757. Europe: 44-1/493-1138.

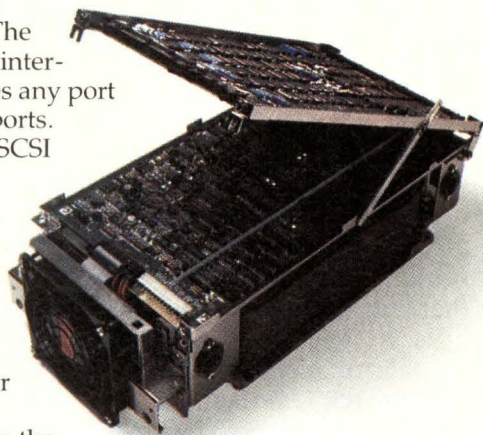

```

ISR   IN A,[PIACRA]           ;test PIA control register A
      BIT 7,A                 ;if byte present
      JR Z,NEXT1             ;then
      IN A,[PIAIN]           ; read byte from input port
      store byte
NEXT1 IN A,[PIACRB]           ;test PIA control register B
      BIT 7,A                 ;if output acknowledgment
      JR Z,ENDISR           ;then
      IN A,[PIAPRB]          ; read byte to reset int. flag
      LD A,0
      LD [OUTFLG],A          ; reset OUTFLG
ENDISR EI                     ;enable interrupts
      RETI

```



```

OUTPUT LD A,[OUTFLG]         ;repeat
      CP 0                    ; test output flag
      JR NZ,OUTPUT          ;until flag is zero
      get byte in A
      DI                     ;disable interrupts
      OUT [PIAPRB],A         ;output byte to output port
      LD A,1
      LD [OUTFLG],A          ;set OUTFLG
      EI                     ;enable interrupts
      RET

```

Fig 5 There is no implicit buffering in either the interrupt service routine or the sense status output routine for driving Occam channels with synchronization.

Similarly, output to a channel cannot take place until the previous character has been sent and an acknowledgment received. This schema does not exactly parallel the Occam channel principle since the synchronization is between an Occam process and system software rather than between Occam processes directly. For practical purposes, however, the analogy is sufficient.

The multitasking environment

Having established very low level system software to service channels, further software layers are required to handle the queuing and dequeuing of processes, as well as their interaction with system routines. With a dual-processor system, it is unlikely that any processor will have a single, dedicated process. Therefore, each processing element must be able to manage multitasking requirements. In implementing Occam channels, there are two categories to consider. The first is where communication is desired between two processes on the same processor; the second case occurs where a channel links processes on separate processing elements.

To run a multitasking environment, a small runtime system has been designed around the data structures shown in Fig 6. The channel and the process are the system's basic building blocks. A channel is represented by 9 bytes of information, containing the channel identifier (1 byte); the next channel in the list (2 bytes); the channel status byte (1 byte); a

1-byte buffer (1 byte); the donor process (2 bytes); and an acceptor process (2 bytes).

The channel identifier is a single byte with the MSB set to zero, making the maximum possible number of channels 64. The MSB of this field will be used later in the multiprocessor implementation. The donor process field is a pointer to the process supplying data to the channel; the acceptor field is a pointer to the process receiving data from the channel. If either of these pointer fields are null, it signifies a process external to this processor.

The status byte has the following significance: bit 0 (0 = buffer empty, 1 = buffer full); bit 1 (0 = donor not queued, 1 = donor queued); and bit

With a dual-processor system, it is unlikely that any processor will have a single, dedicated process.

2 (0 = acceptor not queued, 1 = acceptor queued). The data structure representing the process has 5 bytes: the status byte (runnable or unrunnable) has 1 byte, the next process in the list has 2 bytes, and the pointer to process stack has 2 bytes.

Fig 6 demonstrates the configuration necessary to implement the small Occam program in Fig 1. Along with the program's input, arithmetic, and output processes, there are two extra processes. A serial, sense status output process sends data bytes

IN OCTOBER 1984, 1 MEGABIT BUBBLES WILL BE \$99.*

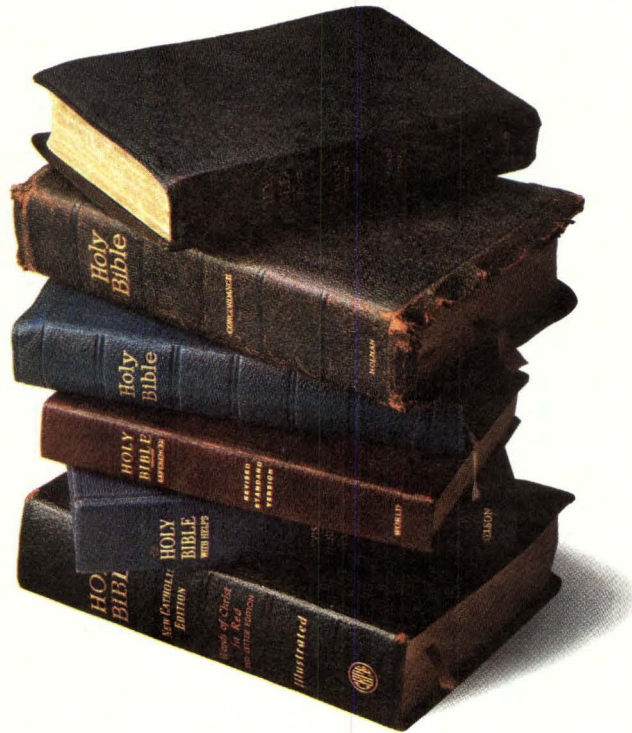

*In 1980, we guaranteed the lowest 1 MB bubble price through 1982 and delivered. Now we're doing it again. With our BPK70-4, in quantities of 25,000 or more. So call (800) 538-1876 for details. In California, (800) 672-1833. And book your order now.

intel delivers
solutions

© 1983 Intel Corporation

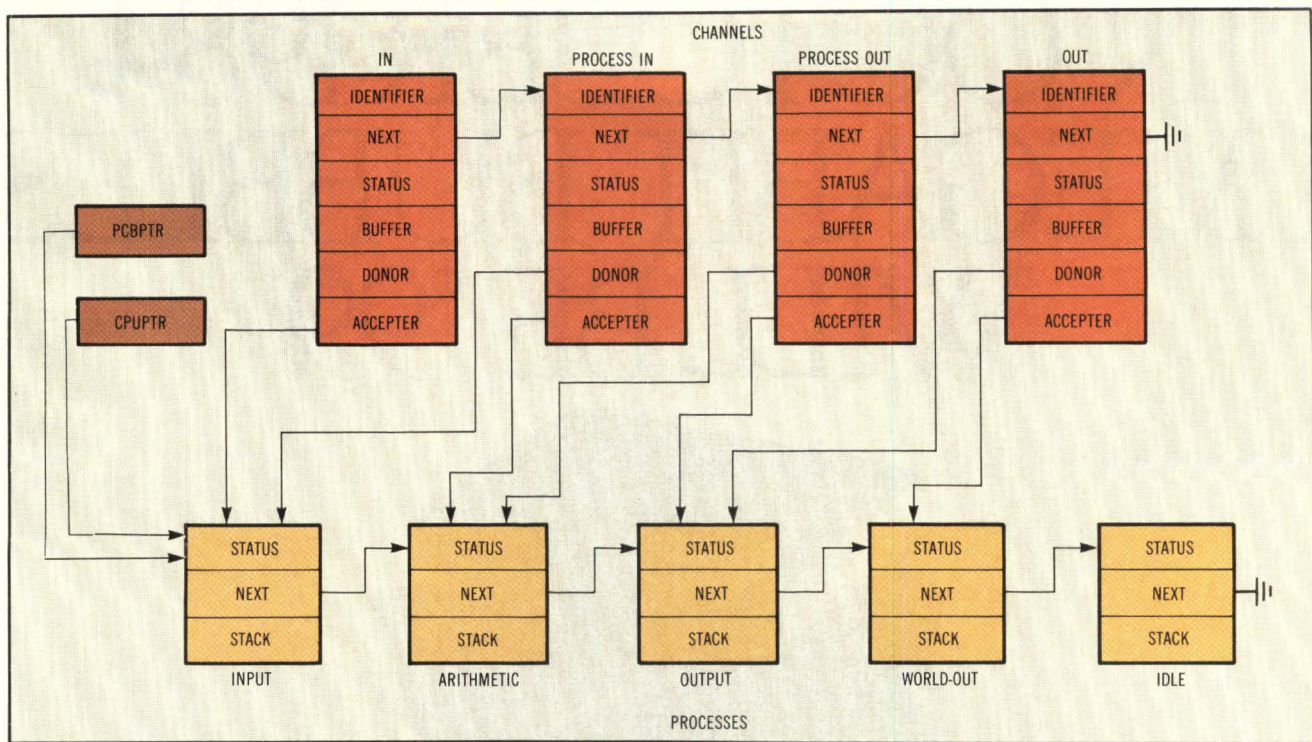

Fig 6 Multitasking environment data structures show both channels and processes organized as linked lists, with each element in the list containing a pointer to the next element. The structures shown implement the program in Fig 1. Two pointers, PCBPTR and CPUPTR, point respectively to the head of the list of processes and the process currently running.

to the outside world via the serial interface; an idle process is the end of the process queue and performs an endless loop until interrupted. The head of the process queue is pointed to by the variable PCBPTR. Similarly, the process currently running is pointed to by CPUPTR.

Extremely basic, the scheduling algorithm merely inspects the queue of processes and selects the first one that is able to be run. This process resumes operation one instruction beyond where it was interrupted. Each process has its own stack: when a process is suspended, its registers and program counter are pushed on to its stack. The stack pointer is stored in the third field of the process data structure. On resumption, these registers are restored with the program counter and the stack once again becomes the working stack.

The channel management routines must handle the buffer manipulation, as well as process queuing and dequeuing. Algorithmic outlines (Fig 7) implement the Occam channel operators ? (input) and ! (output).

Queuing a process takes the following form: mark the process as queued in the channel status byte; mark the process as unrunnable in the process status byte; suspend the process; and call the scheduler. Dequeuing is simpler, as there is no need to suspend the process currently running. The dequeue routine will mark the process as dequeued in the channel status byte, mark the process as runnable in the process status byte, and continue with the current process.

These algorithmic outlines implement Occam channels on a single-processor system. For a multi-processor system, another level of complexity is introduced.

```

chan_in: test channel status byte
        IF buffer contains a byte
        THEN
label1:  pick up byte
        mark buffer empty in channel status byte
        IF donor process queued
        THEN dequeue donor process
        ELSE
            queue this process
            on resumption, return to label1
chan_out: test channel status byte
        IF buffer is free
        THEN
label2:  put byte in buffer
        mark buffer full in channel status byte
        IF acceptor process queued
        THEN dequeue acceptor process
        ELSE
            queue this process
            on resumption, return to label2
    
```

Fig 7 Pictured are the algorithmic outlines implementing the ? (input) and ! (output) Occam channel operations.

Welcome the newest member of the Panasonic non-impact printer family.

Meet the EUY-3T, the new Panasonic Non-Impact Printer that's minimal in size but not in capability. It prints 40 alphanumeric characters on 80mm paper. Offers thermal printer performance with dot addressable graphics capability. And low power requirements (just 5V/2.5A) make it very economical to operate.

It's the latest addition to a line of electrosensitive and thermal printers famous for being big in reliability, but small where it counts: in size, in cost and in operating noise.

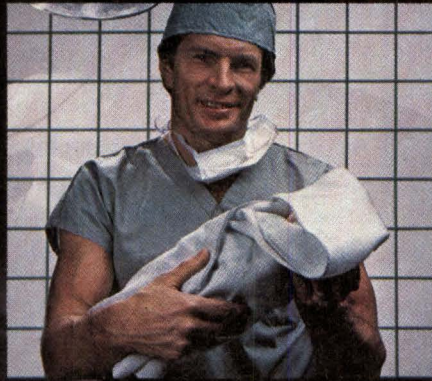

All Panasonic Non-Impact Printers have low all-DC power requirements. And our microprocessor interface modules accept 8-bit Parallel or byte Serial data input (model 3T is also Centronics-compatible). So they're perfect for ATE, printing calculators or other designs requiring low-cost hard copy.

Think our new baby is cute? Ask for complete data and prices - contact Panasonic Industrial Company, Electronic Components Division, One Panasonic Way, Secaucus, N.J. 07094; (201) 348-8080.

At 14 ozs., it's positively precocious.

Series	Column Capacity	Paper Width	Outside Dimensions
EUY-2	15	36mm	71.9 x 33.5 x 55.9 mm
EUY-3T*	40	80mm	121 x 48.5 x 67 mm
EUY-10	15, 21, 32, 40	60mm	90.4 x 42.4 x 110 mm
EUY-5	32, 40, 64, 80	127mm	195 x 65 x 70.1 mm

*Thermal only

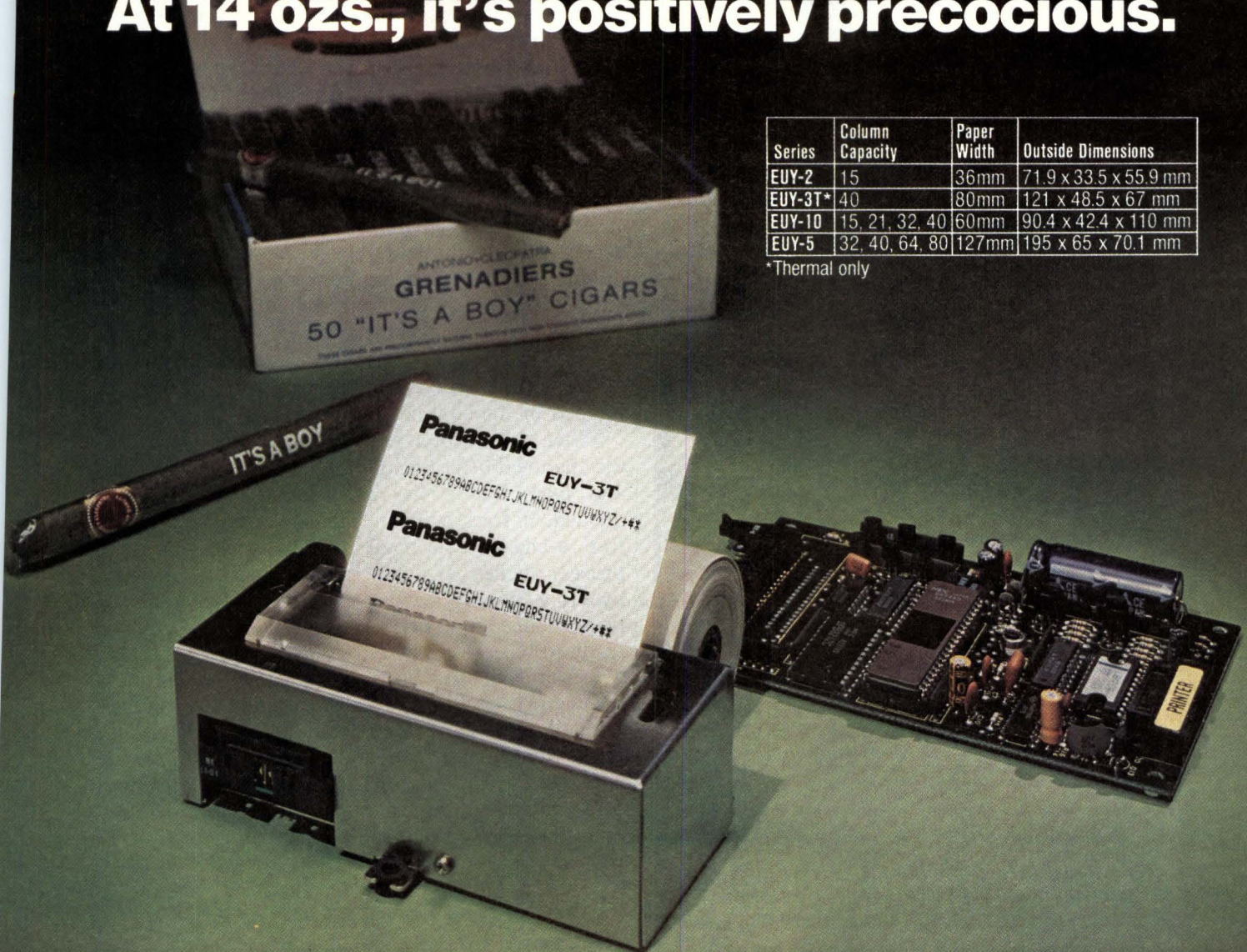

Panasonic
Industrial Company

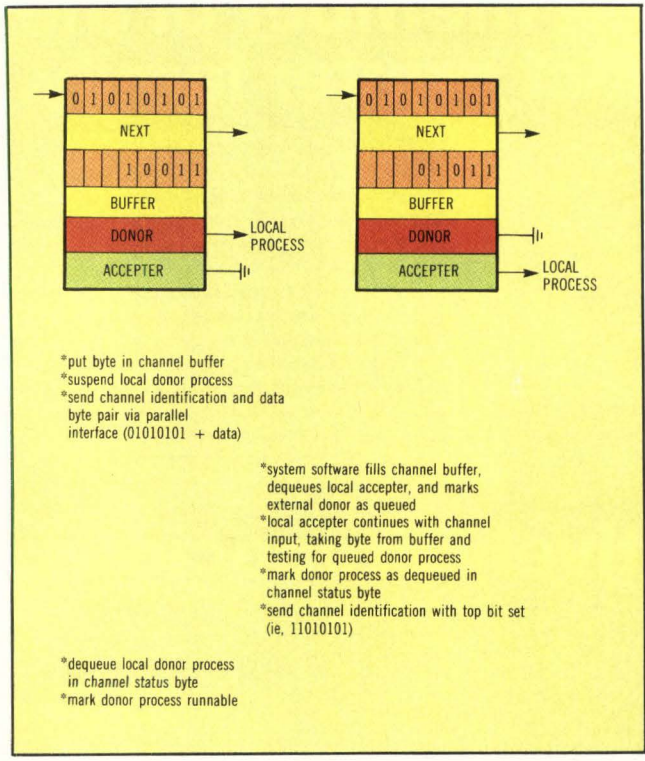

Fig 8 Synchronization for channel buffers require that PIA transmits channel identification and data bytes to an external acceptor process. A byte containing channel identification with the top bit set is sent to suspend the donor process.

When a system consists of more than one processing element, changes must be made so that a process can be recognized as being local or external to a processor. To this end, two more bits of the channel status byte are used: bit 3 (0 = donor local, 1 = donor external); and bit 4 (0 = acceptor local, 1 = acceptor external).

Channel implementation for multiprocessors

If a channel donor process is external, the channel input routine must have some conception of how to dequeue an external process. To do this, a message is sent via the PIA to the other processor, containing the channel identifier with the most significant bit set. On receiving this message, the processor can inspect the relevant channel, determine which process is in question, and proceed to dequeue this process, making it able to be run.

Synchronization along the channel will be maintained on a byte level by the hardware handshake and simple assembler routines in Fig 5. On a higher level, data must be passed by the parallel interface in byte pairs: the first byte will give the channel destination; the second byte will be the actual data. To prevent overflow of the channel buffer, the process that donates a byte to a channel for an external acceptor must immediately suspend itself having donated the byte to the channel buffer. The system software handles data coming in from the parallel port and must place the data byte in the correct channel buffer, dequeue the local acceptor process (if queued), and mark the external donor process as queued in the channel status byte.

When the acceptor process removes the byte from the channel buffer (using the channel input operator) and finds that it has an external donor process queued, it frees it in the manner discussed. Therefore, a channel will never have an external acceptor process queued. If a process is allowed to output a byte to a channel (because the process is runnable), it is guaranteed that the external acceptor process is ready to receive the byte (see Fig 8).

Occam is the first language of a new generation. It is designed specifically for concurrency and parallelism, as opposed to a conventional, sequential language that must have added features to provide parallelism. This extremely simple yet powerful tool offers programming techniques that were previously unavailable in a multiprocessing environment.

New Inmac Catalog jam-packed with computer/wp supplies. Yours free!

Accurately called "the bible of the industry," it's loaded with great products and ideas for your personal computer, minicomputer or word-processing system. You'll enjoy:
 ■ **One-stop shopping.** Over 2,000 products to choose from.
 ■ **Easy ordering.** Mail, phone, or TWX. Verbal P.O.'s welcome.
 ■ **Fast delivery.** 24-hour shipment. Overnight emergency shipments available.
 ■ **45-day trial.** Full refund if not completely satisfied.
 ■ **Guaranteed quality.** All products field-tested to highest standards.
 ■ **Lower shipping costs.** 8 fully stocked distribution centers serving the U.S.

For fastest delivery of your free 100-page Inmac catalog, call 1 (800) 547-5444. 1 (800) 547-5447 in California.

inmac Catalog Dept., 2465 Augustine Drive, Santa Clara, CA 95051
 Please be sure to include your phone number. 108111

NAME _____ PHONE _____
 COMPANY _____
 ADDRESS _____
 CITY _____ STATE _____ ZIP _____

Please rate the value of this article to you by circling the appropriate number in the "Editorial Score Box" on the Inquiry Card.

High 710 Average 711 Low 712

THE WY300 TERMINAL GREAT COLOR FOR UNDER \$1000



IF COLOR IS A LUXURY YOU THINK YOU CAN'T AFFORD, THINK ABOUT OUR WY300—the smart color terminal as low as \$975.*

*Quantity 100

The WY300's high-resolution 8-color display adds vivid relief to any text editing or data entry task, without adding significantly to the price you'd pay for monochrome.

Ergonomically designed with a swivel and tilt CRT and a detachable keyboard, the compact WY300 fits into the workplace as comfortably as it does into your budget.

On top of that, the WY300 gives you a host of features like a soft downloadable



character generator; extensive alphanumeric and line drawing symbols; and compatibility with most standard,

monochrome oriented, off-the-shelf software.

Best of all, the WY300 is plug compatible with our monochromatic WY100's and most ASCII terminals. So, using color is as easy as it is inexpensive.

Need more information? Call or write us today. We'd like to convince you our smart color terminal is your wisest buy.

WYSE

Make the Wyse Decision.

WYSE TECHNOLOGY 3040 N. First St., San Jose, CA 95134, 408/946-3075, TLX 910-338-2251, Outside CA call toll-free, 800/421-1058, in So. CA 213/340-2013.

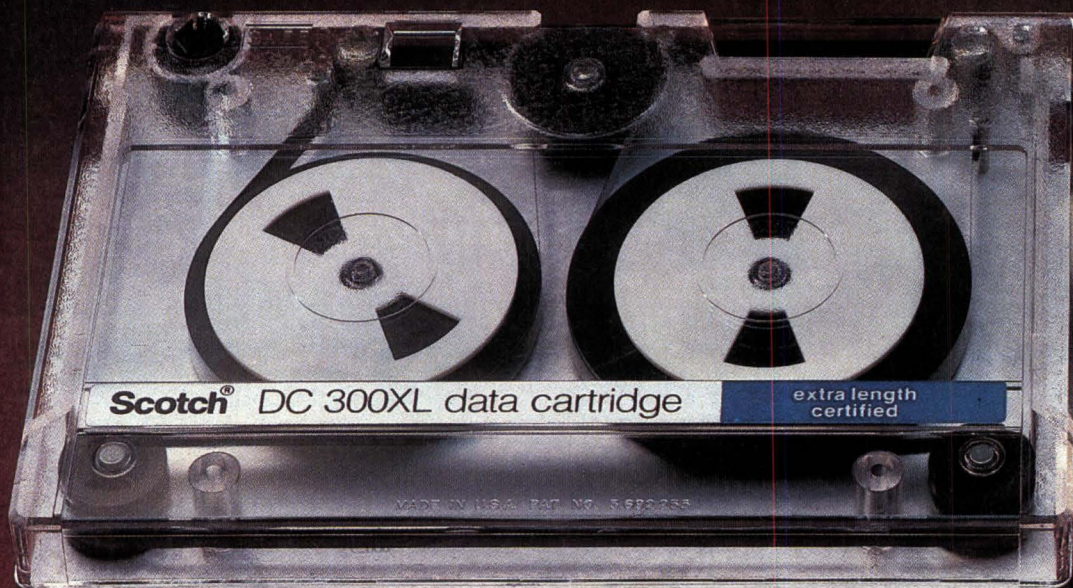

The design solution: Winchester

Save your customers time, space, and money with ¼" data cartridges.

When 3M invented the ¼" data cartridge, they designed it to be fast, dependable, small in size, and big in capacity — up to 67 megabytes today, with more in store for the future. No wonder more and more systems

designers are finding it the perfect choice for backing up Winchester drives. 45 megabytes of data can be transferred from disk to tape in under nine minutes — with no time lost for media changes. One cartridge does it all! It would take a stack of 38 eight-inch floppies* to hold the same amount of data. The cartridge

is small enough to fit in a coat pocket — and rugged enough to be transported that way, too.

New rules of standardization. Industry standards are now being formulated which will improve interchangeability of ¼" recorded data cartridges across most major manufacturers' ¼" drive systems.



back-up that eliminates stack-up.

This means concerns about compatibility are diminishing.

The logical choice.

The 1/4" data cartridge is the logical choice for designers specifying back-up systems for Winchester drives. It's small, reliable, easy to handle and transport, and has a very low cost per megabyte.

These high capacity cartridges are useful for archival storage and program loading, too. So don't wait, give your customers the future. Put this innovative technology to work in the next computer system you design. Data cartridge drives are available from over 30 manufacturers throughout the world.

For more information:

For more information on how 3M 1/4" data cartridges can save your customers time, space, and money, write to Chris Binner, National Sales Manager — OEM Market, Data Recording Products Division, Building 223-5N, 3M Center, St. Paul, MN 55144.

*Double sided/double density 1024 format 8" diskettes.

3M hears you...

3M

Gould Development Systems

The 9516S Microsystem Integration Station.

If your microprocessor software has been developed on a VAX™ or PDP-11,™ only one emulator lets you download your executable code for total standalone debugging.

The Gould 9516S Microsystem Integration Station.

It's DEC-compatible so there's no need for software conversion.

Because it's standalone, you leave your host free for other projects, including continual code development.

The fact is, with an RS-232-C interface, you can use the 9516S with any host computer or development system.

Multi-Ice™ supports four μPs at once.

For debugging multi-processor systems quickly, the 9516S Multi-Ice™ lets you control and monitor any combination of four 8- or 16-bit microprocessors.

Simultaneously. In parallel. And in real-time.

Which means instant hardware communications between microprocessors. Synchronization of program execution. And interleaved display of independent trace buffers.

You can perform logic trace analysis. High speed memory emulation. Complex and super breakpoints.

Built-in procedural language interpreter.

The 9516S procedural language interpreter is a very powerful yet flexible tool derived from the high-level "C" programming language. It offers you a debug environment much like your own high-level programming environment, giving you the option of bypassing assembly language.

During debug and systems integration, it lets you manipulate and display data, access system resources, and control those resources.

In short, the procedural language interpreter will dramatically increase your effectiveness and productivity.

You can interrogate and make decisions based on real-time information from the 9516S hardware resources. Including software program analysis. Automatic test set-up and execution. Simulation of target hardware. And post-processing analysis.

No more "wait states."

With the 9516S you can specify up to 8 complex and 4 super breakpoints. Use 80 channel and 1,024 word-deep trace memory for exceptionally qualified logic trace. Or gather information in real-time and display it—while the target system continues to be emulated.

The world's fastest 68000 Emulator.

And now we've added the world's fastest 68000 Emulator to the 9516S,

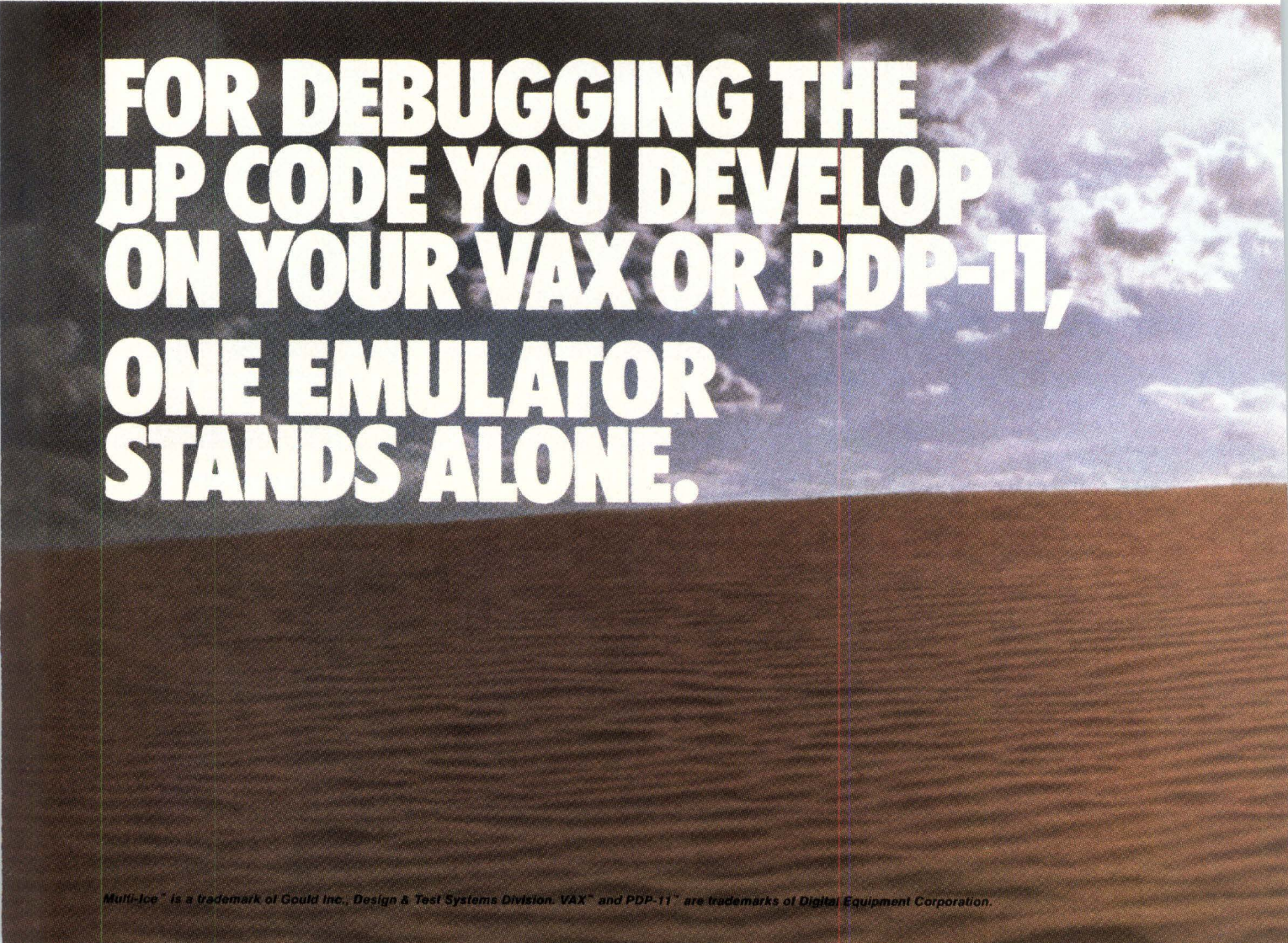

**FOR DEBUGGING THE
μP CODE YOU DEVELOP
ON YOUR VAX OR PDP-11,
ONE EMULATOR
STANDS ALONE.**

Clearly the Best.

a new option that emulates in real-time at clock rates up to 12.5 MHz.

Its instruction prefetch is monitored by a unique tracking circuit that enables accurate real-time trace and breakpoint capabilities. So now you can break on conditions executed by the 68000 processor as well as those appearing on the bus.

Uncompromising dedication to high performance.

At Gould, we believe in making every instrument clearly the best.

The standalone capability, procedural language interpreter, multi-processor control and human interface characteristics of our 9516S are evidence of that commitment to excellence.

For detailed application notes or a demonstration, write Gould, Inc., Design & Test Systems Division, 4600 Old Ironsides Drive, Santa Clara, CA 95050-1279.

For fastest response, call toll-free: Nationwide (800) 538-9320; In California (800) 662-9231 or (408) 988-6800.

AND NOW . . .
THE FASTEST
68000 SUPPORT.



*The Gould 9516S Microsystem Integration System supports **any** combination of 68000, 8086, 8088, Z8001, Z8002, 68B09E, 8085A and Z80A microprocessors. It includes a 1 megabyte thinline double-density, double-sided floppy disk drive. Its RS-232-C port lets you interface with any minicomputer for fast, effective software development.*

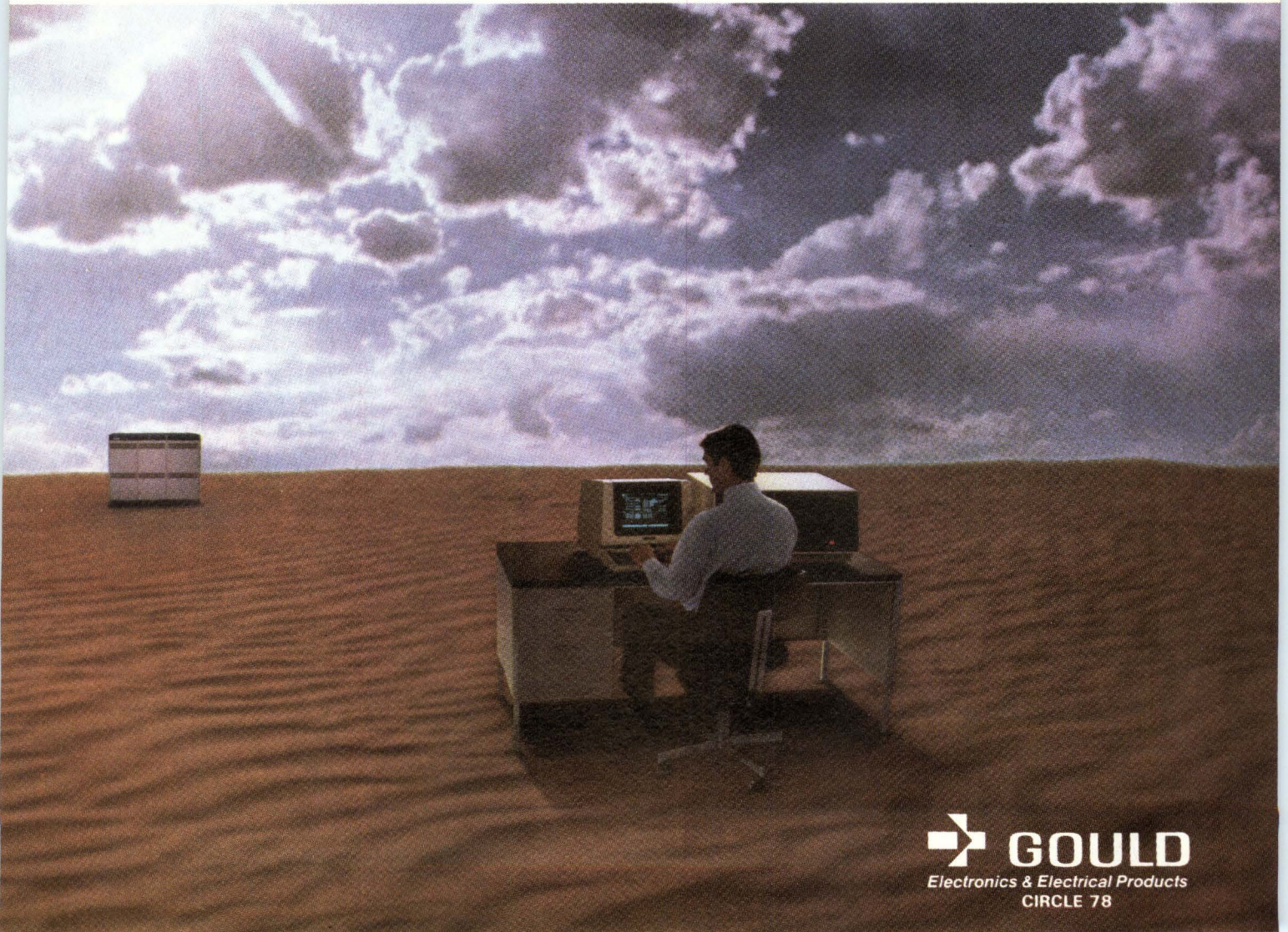

 **GOULD**
Electronics & Electrical Products
CIRCLE 78

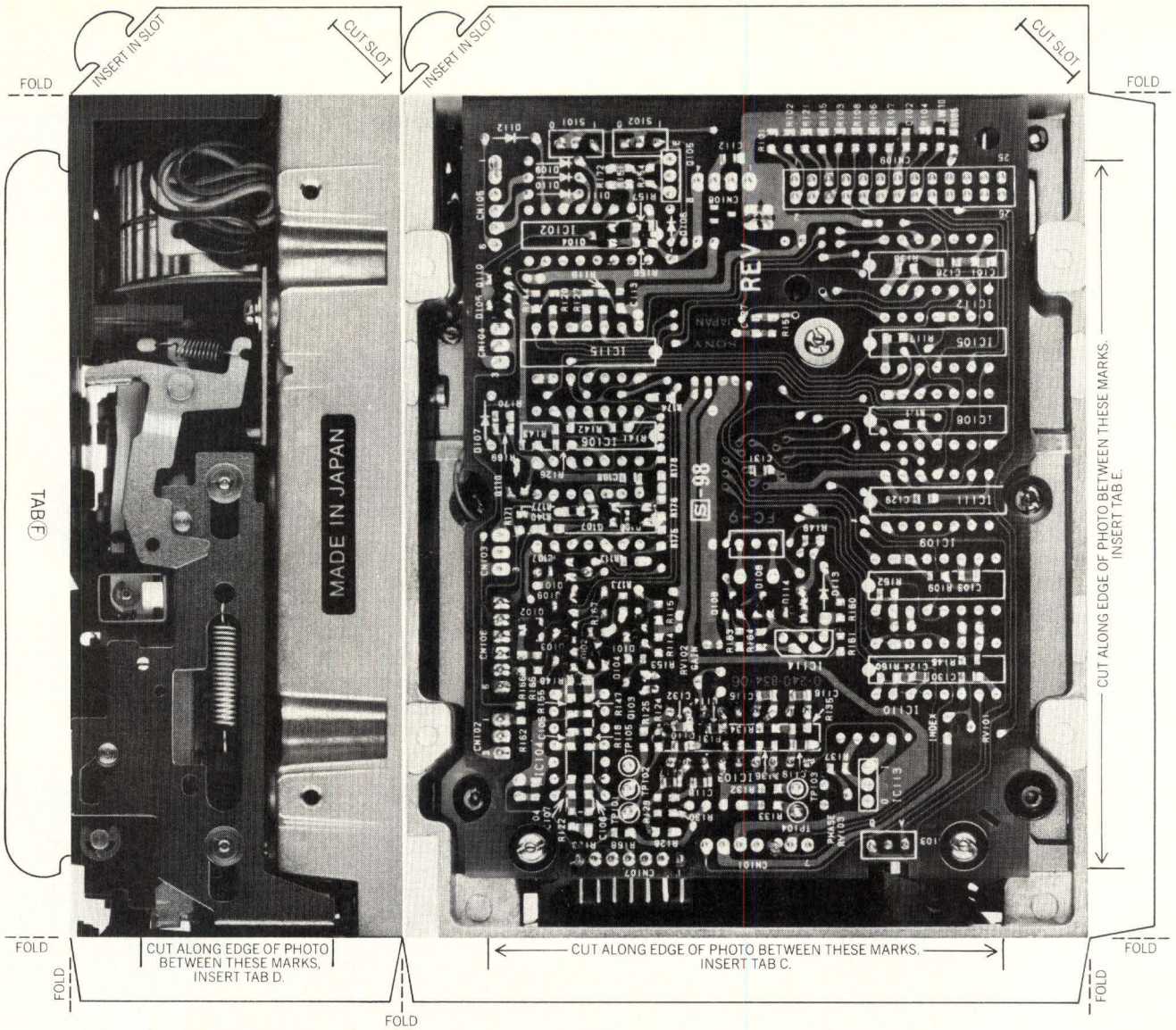

**THE NEW
SONY
1 MEGABYTE
SYSTEM.
TRY IT ON
FOR SIZE.
(SOME ASSEMBLY REQUIRED.)**

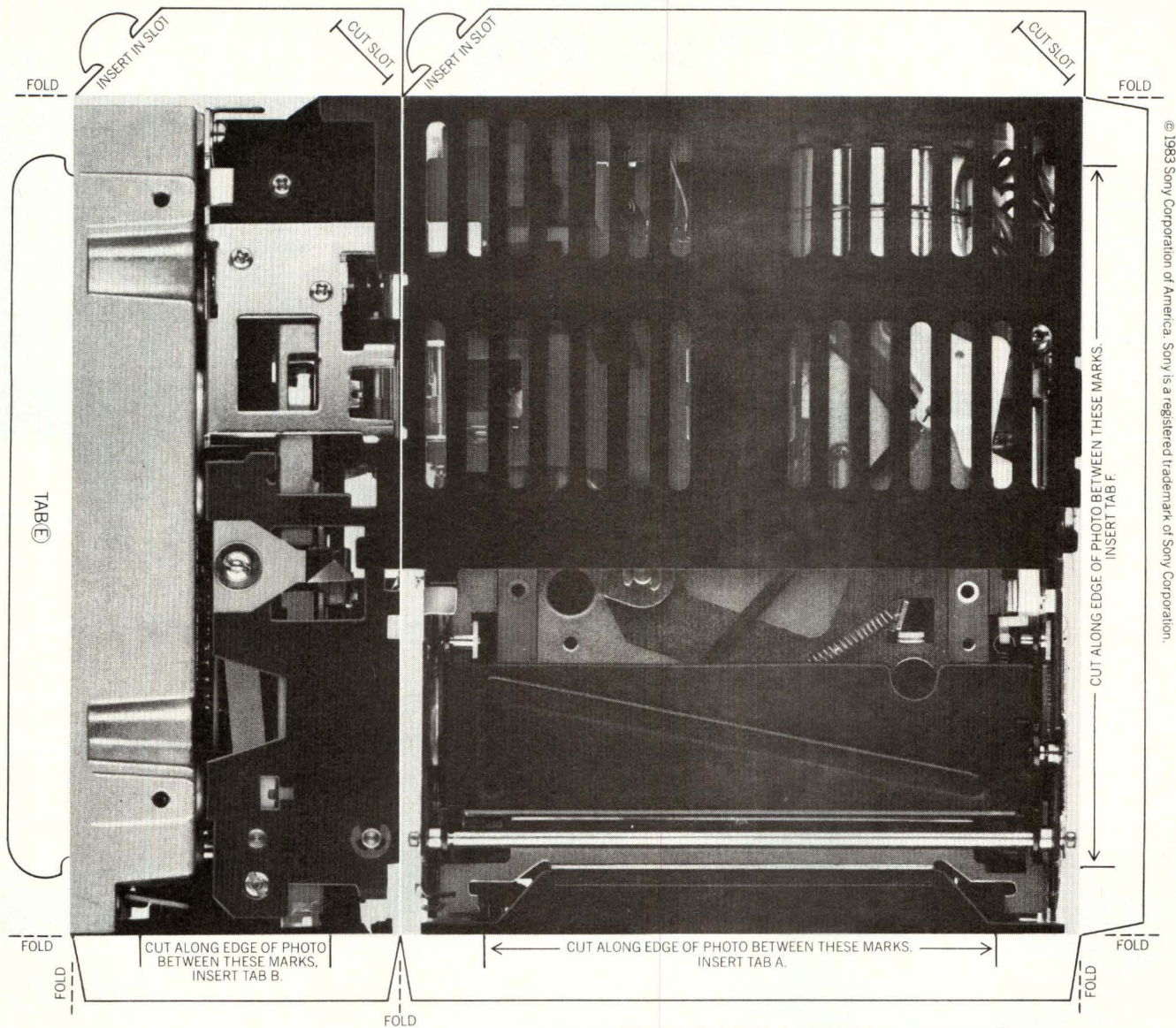

© 1983 Sony Corporation of America. Sony is a registered trademark of Sony Corporation.

If your mass storage needs are truly massive, but your space is minuscule, get out your scissors. And get in on the cutting edge of Sony technology. The innovative Sony double sided, double density Micro Floppydisk is only 3½" on a side, but a whole Megabyte deep. And you can fit two Sony 3½" drives into the same cubic space as one ordinary 5¼" unit. Think of all the programs and applications that will hold. And, drive for drive (1 Meg or 500 K), Sony costs no more.

Try this Sony on for size. When you see how well it fits your needs, we'll get you as many as you want. Fully assembled.

For more data, call (N.J.) 201-930-6030 or (Calif.) 415-961-9060.

How to assemble life-size Sony Micro Floppydisk system: Remove these pages and paste to cardboard. Cut out 3½" Micro Floppydisk, front

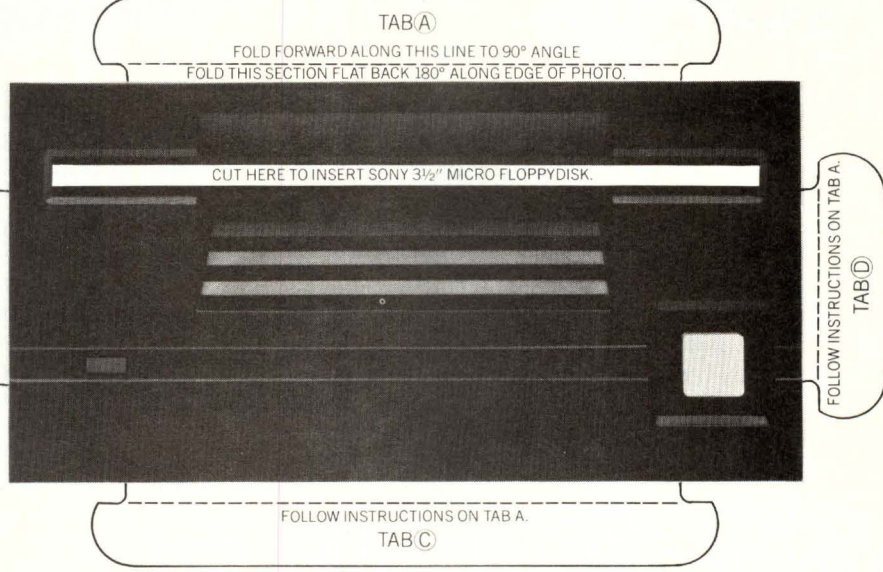

panel of drive, and remainder of drive (cutting around tabs). No, you haven't lost the back panel. We didn't include it. Now cut slots for tabs and cut space in front panel for disk. Fold, and insert tabs, where

indicated. Now see how comfortably one Megabyte fits into the prototype of your choice.

SONY.

Data Products
Sony Communications Products Company

**A BIG CHANGE
THAT HASN'T CHANGED
OUR PRODUCTS
IS OUR NEW NAME.**

GENICOM



Normally, you might not trust a product with a new name. But while all of our products have a new name, they also have a proven history of quality and reliability.

That's because Genicom was formerly the Data Communication Products Department of General Electric. Now an independently owned company, Genicom will continue the same product line we established with GE...only the name has changed.

Our Genicom 3000 family, for instance, still offers the same performance features already preferred by users and the design flexibility so important to OEM's, distributors, retailers and dealers. Speeds from 40 to 400 cps. Single or dual mode printing. Type quality from EDP to NLQ. Multi-color printing. Graphics. Selectable type fonts, American craftsmanship and more.

Of course, we'll also offer Genicom 2000 tele-

printers and the soon to be introduced 4000 shuttle matrix printers. You'll find we have the same complete product line that we had with GE. We have the same corps of experienced employees, the same facilities, and the same nationwide service network.

But above all, we have a new commitment to excellence. Which means, while we continue to serve existing customers with established products like our 3000 family, we plan to introduce more products to meet growing needs.

At Genicom, we've changed our name and we're planning to change the future with more innovations, and more of the quality you've come to expect from us under any name.

Genicom Corporation, One General Electric Drive, Dept. M321, Waynesboro, VA 22980. In Virginia, call 1-703-949-1170.

GENICOM

For the solution to your printing needs call
TOLL FREE 1-800-437-7468

CIRCLE 80

SPECIAL REPORT ON DESIGN TOOLS

The pace of innovation in systems that incorporate embedded microprocessors and, in increasing numbers, bit-slice processors has become a blur. Both the complexity of the processors themselves and the sheer size of the applications that they support have created a demand for a whole new generation of hardware instrumentation and software tools. Of primary importance these days is the development team—a group of hardware and software specialists who spend an increasing amount of time in activities that partially overlap.

Thus, a means is needed to tie together the jobs of team members and allow them to speak a common language. The level of communication occurs in terms of the system functions and cannot be expressed in a meaningful way to all team members as either processor instructions or circuit nuances. The common tongue they are finding is the high level programming language (ie, C, Pascal, or Fortran). It is in terms of these languages that the team members are able to rise above the Babel of their specialties and communicate across the hardware/software range of the system they are developing.

This, of course, places a large burden on the development and test equipment. Not only must development systems be able to communicate with logic analyzers and emulators with data bases, but high level software must be able to select and present the vast volume of data in ways that a human can interpret. Thus, compilers and debugging software need additions and interfaces to analyze tools and graphics display systems—all of which must let the user control the lowest levels of hardware in terms of symbols rather than the ultimate details. However, the circuit must at the same time be accessible, in its smallest detail, from the high level language.

Beyond the integration of functions among design team members, today's development tools must provide ways for management to maintain control of the development effort. This means that version control, electronic mail, word processing, and many other functions usually associated with the normal office, must be linked to the technical design environment. The challenge of the new world of engineering has just begun, and as the industry progresses, more and more of the most sophisticated products yet known will be designed on the basis of *what* they are supposed to do rather than on specifically *how* they are supposed to do it.

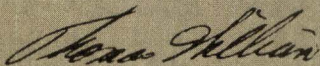

Tom Williams
West Coast Managing Editor

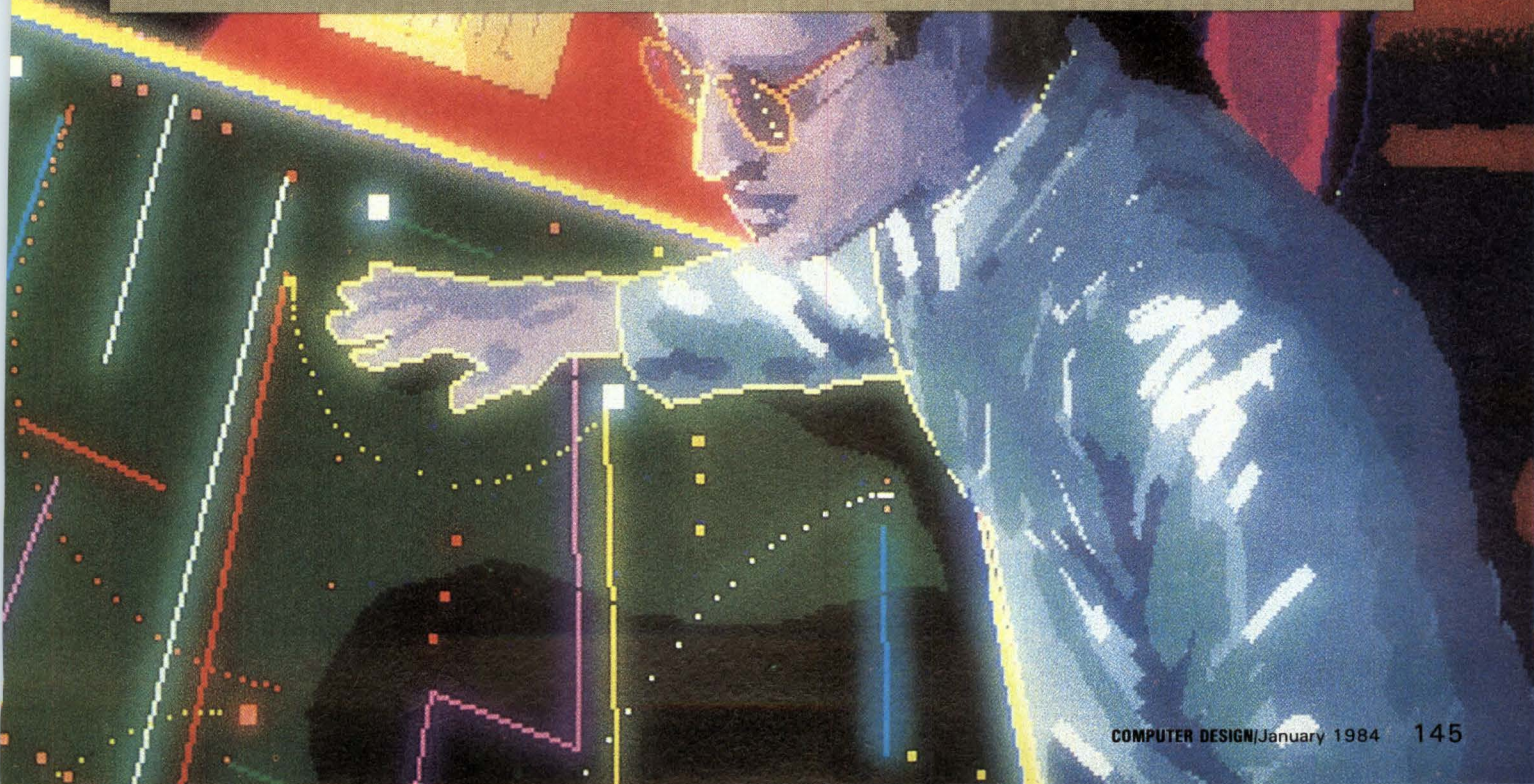

Announcing interactive color imaging at a low, frame buffer price.

Now, for no more than the cost of a frame buffer display, there's an interactive imaging display subsystem that offers a level of functionality previously found only in high-priced systems.

With the fast microprocessor and functional firmware of Lexidata's new IMAGEVIEW™, all operations are performed locally. The command set provides the widest array of industry-standard functions available. Operations which used to require a subroutine can now be done with one command, drastically reducing host processing time.

What makes IMAGEVIEW so uniquely interactive? The

combination of ultra-high-speed text and graphics processing with the ability to handle multiple images. An exclusive image data management system permits users to divide display memory into any number of independent workspaces, called Virtual Images.™ High level commands perform functions on individual images, on specific areas within images, and between images. The simplicity of the IMAGEVIEW approach increases overall system throughput and decreases program development time.

Region Of Interest processing, another powerful IMAGEVIEW feature, allows the user to specify an area of any size

and shape, and process it separately from the rest of the image... perfect for area and volume calculations and cut-and-paste operations.

For working with thresholds, color translations, and for assigning gray-scale values, IMAGEVIEW Virtual Lookup Tables™ allow users to operate on displayed data in real-time without altering stored images.

To improve your image, call 1-800-472-4747 (in Massachusetts, call 617-663-8550), or write to us at 755 Middlesex Turnpike, Billerica, MA 01865. TWX 710-347-1574.

LEXIDATA
The clear choice in raster graphics.

CIRCLE 81

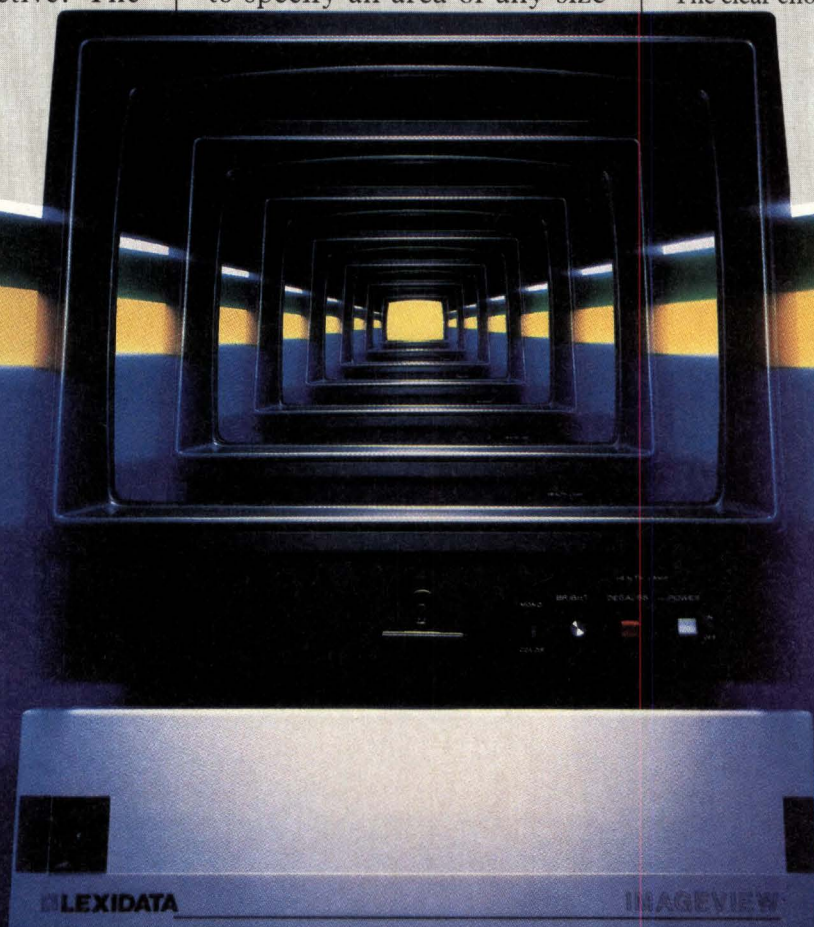

Special report on design tools

- 149 Development systems: big chips require high level tools**
by Tom Williams and Joseph Aseo—High level development languages, multi-user networks, and powerful software debugging and analysis tools are rising to the challenge of 16- and 32-bit processors.
- 171 Microprogramming versus microprocessors**
by Bjorn Dahlberg and Wendy Kane Wanderman—Designers who choose a standard microprocessor chip may quickly discover that semicustom and custom variations have boxed them out of the market, and that microprogramming is indeed the wave of the future.
- 183 Expanded design cycles demand new development tools**
by John R. Adam—Make sure that microprocessor development tools support rather than dictate the design.
- 193 Simplify programming of realtime systems**
by Evan Solley—Designers need development tools to test and interactively refine realtime applications. A tool for testing a routine in a high level language and then compiling it into a compact ROMable form is very valuable.
- 205 New tools build microsystems**
by Larry Badagliacca—Designing modern 16-bit computer systems requires a new set of tools. Modularity and a variety of realtime tools increase productivity.

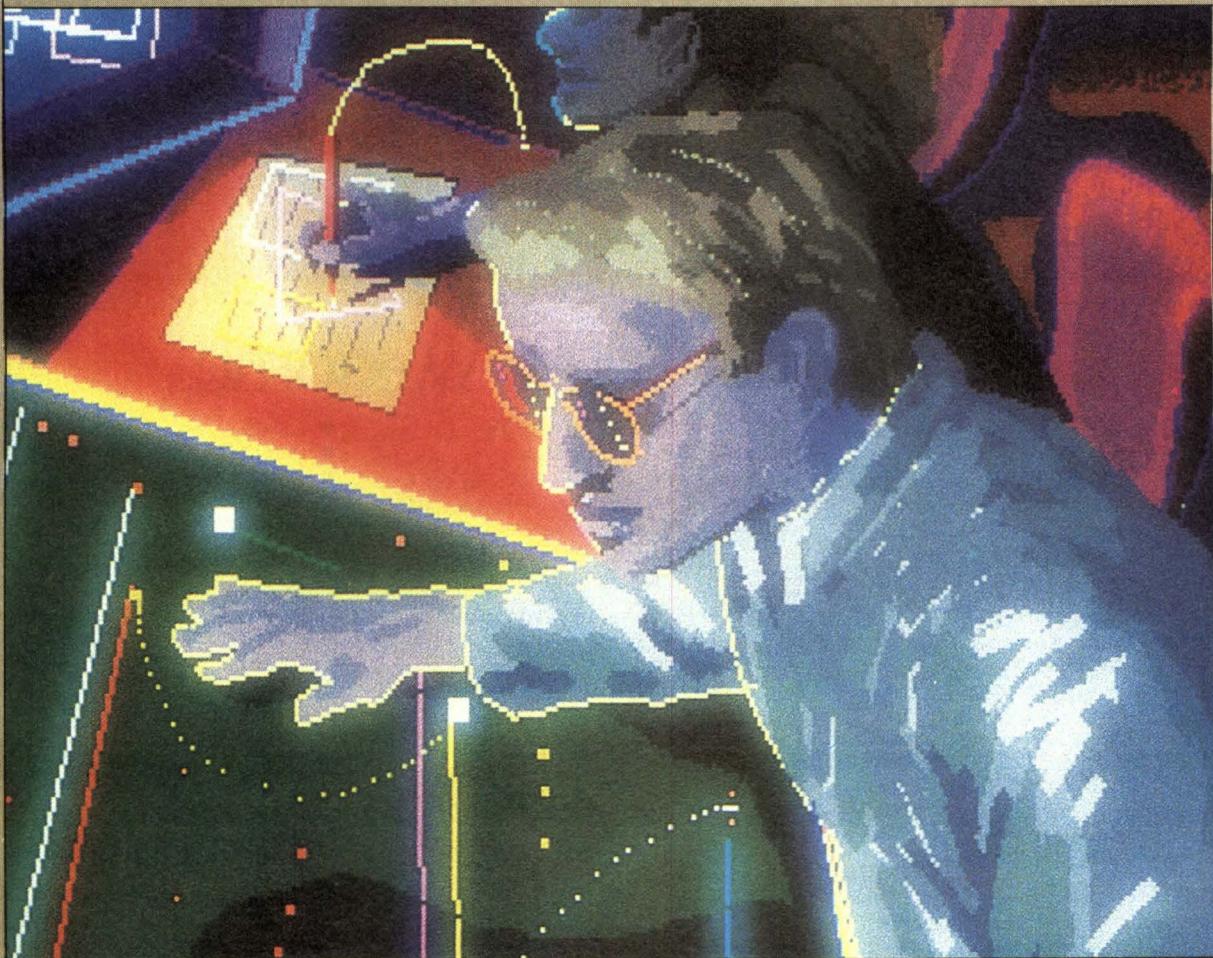

Dolch.

advanced logic analysis

64300



...tops out at 300. Awesome.

High-Speed Logic Analysis Doesn't Have To Be Expensive.

The Dolch System 64300. The newest addition to the Dolch logic analyzer family. With 64 channels. Data acquisition speed up to 300MHz. And a level of overall performance previously unavailable at this low price.

DATAPAK—Logic Analyzer Data In Pocket Size.

DATAPAK is a unique compact cassette for storing recorded data for future use. Simply and effectively. Using non-volatile EEPROMs (safe under the harshest environmental conditions), each DATAPAK can store up to four complete instrument setups—plus reference data and option software.

Simplified Operation.

The 64300 is an "active" logic analyzer. At any time, a "monitor" can be called up to compare the total measurement configuration with the instrument setting, analyze its potential and, in precise language, suggest corrective steps.

Configureability—The Key To Optimal Price/Performance.

The 64300 can be equipped with up to four 16-channel modules. This modular approach permits a diverse configuration of channels, speeds and recording depths to be implemented.

The 64300 Performance Advantages.

- 16 to 64-channel configureability
- Up to 300MHz
- Memory depth of up to 4kbit/channel
- 5ns glitch detection
- DATAPAK compact portable mass memory
- Software, time and performance analysis including histogram
- Sequential and single word search
- Complex data comparison and analysis
- Active HELP with the MONITOR feature
- Total mnemonic disassembly for all popular 8 and 16-bit micro-processors

- Data-selective tracing
- Dual time basis
- Multilevel cycle generation
- Standard interfaces include GPIB and RS-232

The System 64300. From Dolch. The leader in high-performance logic analysis. If you'd like to know more about the 64300, or any of Dolch's other logic analyzer systems, call or write us today. Or ask for a demonstration from the Dolch representative in your area.

Dolch Logic Instruments
3052 Orchard Drive
San Jose, CA 95134
(800) 538-7506
(408) 945-1881 (in California)

Justus-v.-Liebig-Str. 19 D
D-6057 Dietzenbach/West Germany
Tel. (06074) 2066, Telex 4 191 550 dli d

dli **DOLCH**
LOGIC INSTRUMENTS

CIRCLE 82



DEVELOPMENT SYSTEMS: BIG CHIPS REQUIRE HIGH LEVEL TOOLS

High level development languages, multi-user networks, and powerful software debugging and analysis tools are rising to the challenge of 16- and 32-bit processors.

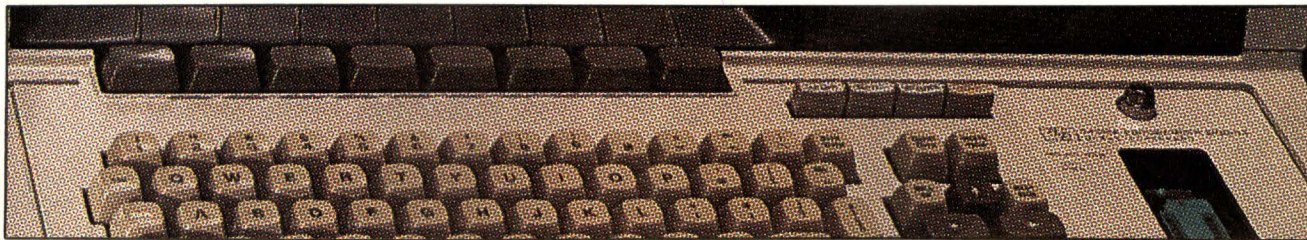

by Tom Williams,
West Coast Managing Editor and
Joseph Aseo, Field Editor

Microprocessors have outstripped the ability of humans to program them without automated assistance. Instruction set complexity, and the vast address ranges available with 16- and 32-bit processors, have catapulted the demands on development systems far beyond assemblers and editors. They require teams of programmers working with both personal and shared resources, and tools to manage and coordinate the activities of both humans and machines. Microprocessors need interfaces to protect existing investments in software and equipment, and to economically incorporate new tools into the design environment. Above all, they demand software machinery to let people get into the processors and make them do work.

High level debuggers, project data bases, source-directed editors, and code optimizers are all part of the manufacturers' push to automate the design process and increase engineering productivity. Unix, and its derivatives, with a hierarchical file structure and an extensive set of programming tools, is becoming the operating system of choice

for managing the advanced development environment. Development systems for custom microprogrammed applications are starting to appear. While they are not yet as technically sophisticated as the microprocessor systems, they will ultimately provide designers with even more flexibility in optimizing systems. Each of these tools makes the design process faster and more cost effective by automating functions that were previously done "by hand."

Engineers and programmers tend to write the same number of lines of code per day, whatever the programming language they are using. This rule of thumb is the chief reason to insist on using high level languages for any software development projects, including those for controllers and embedded applications. With the present price of memory, hardware costs no longer dominate design decisions, but software (labor) costs do. Sixteen-bit CPUs, with expanded address space, have led to larger and more complex control programs. These programs would be prohibitive to build with assembly language, and without software design tools.

Controlling complex projects

Intel (Santa Clara, Calif), in talking about its new Intellec Series IV Microcomputer Development

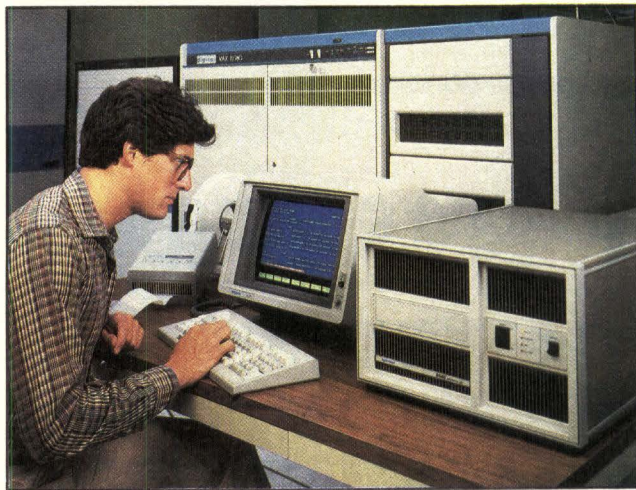

The Integration Control System from Tektronix automates the specification of the hardware/software interface through the use of a menu-driven display.

System (MDS) and Ethernet-based Network Development System (NDS-II), estimates that about 25 percent of development time is spent on writing software, an equal 25 percent on administration and project management, and fully one half on debugging and integrating the code into the product. Automating these functions is an obvious step, but the pieces must work together smoothly to get the most out of them. A uniform user interface from beginning to end, and careful thought to program compatibility, are what the company sees as the main strengths of the Series IV/NDS system.

Fortran, C, and Pascal are the most widely used development languages, and Intel offers these (with systems programming extensions, in the case of Pascal) as part of the system. It also offers its own language, PL/M, and macro assemblers.

The Series IV has a set of tools to handle the two main problems associated with creating the large applications for 16- and 32-bit processors. These include tracking the status of the project and its individual parts, and putting those parts together to make a working whole. One tool, the Source Version Control System (SVCS), is a data base that holds copies of different software module versions, as well as documentation and notes about each. The second, iMAKE, automatically compiles and links the latest versions of the modules to make up a system. iMAKE recompiles and links only in those modules that have been changed. This reduces the need for exhaustive recompilations to incorporate minor changes.

Once the software is written, it is debugged off-line (in the MDS or DEC minicomputer) using Intel's PSCOPE, an interactive high level debugger. This allows the designer to step through the high level source code program, examining and changing variables and source code as necessary. This avoids searching through hardcopy listings or memory dumps, and speeds the development process.

When the target hardware is finally available, the debugged code can be integrated, using the Integrated Instrumentation and In-circuit Emulator (I²ICE). This instrument supports emulation and high level debugging using symbol information supplied by the compiler and stored separately from program code. The symbol information also supports logic analysis, and logic timing analyzer display. The interface back to PSCOPE allows programmers to correlate events in hardware with high level source code.

Much like Unix, the Series IV/NDS operating system, iNDX, features a hierarchical file system, foreground/background processing (one task in each), and a screen-oriented text editor. The iMAKE and iSVCS utilities are also very similar to the Source Code Control System (SCCS) utility offered with Unix.

Tektronix (Beaverton, Ore) provides essentially the same set of functions in the TEK 8500 Series Microcomputer Development Lab (MDL). These include high level languages (Pascal for all emulated processors, and C for the 68000), standalone or DEC minicomputer processing, a smart emulator with a hardware interface for a logic analyzer, and source code debugging. Based explicitly on Unix (TEK's implementation is called Tnix), the MDL system has all of the software tools (eg, SCCS, the Unix "vi" editor, and database managers) which come with it. It also has two additional features, a language-oriented editor, and a code optimizer.

A language-oriented, or syntax-directed, editor "knows" the language it is used with—in effect, it has "keys" which generate typical statements in the language, and can catch and correct typographical errors before the compiler is run. This saves both typing time and frustration. The most common programming error in Pascal, for instance, is a missing semicolon at the end of a statement. The compiler will choke on this error, and the programmer generally feels like choking the computer.

Code optimization is something of a mixed blessing. While an optimizer can do an excellent job of compressing and speeding up compiled code, care must be taken to preserve both debugging information and the program's structure. If too much optimization occurs, the result will bear little resemblance to the source, and critical timing loops may suffer.

Unix on the march

Standard development environments (ie, Unix) provide the common link between Gould Design and Test Systems (Santa Clara, Calif), Kontron Electronics (Culver City, Calif), Motorola Semiconductor (Tempe, Ariz) and National Semiconductor (Santa Clara, Calif). All offer standard languages as well, with Pascal and C being the most popular. Prime differences between these

THE FINISHING TOUCH.

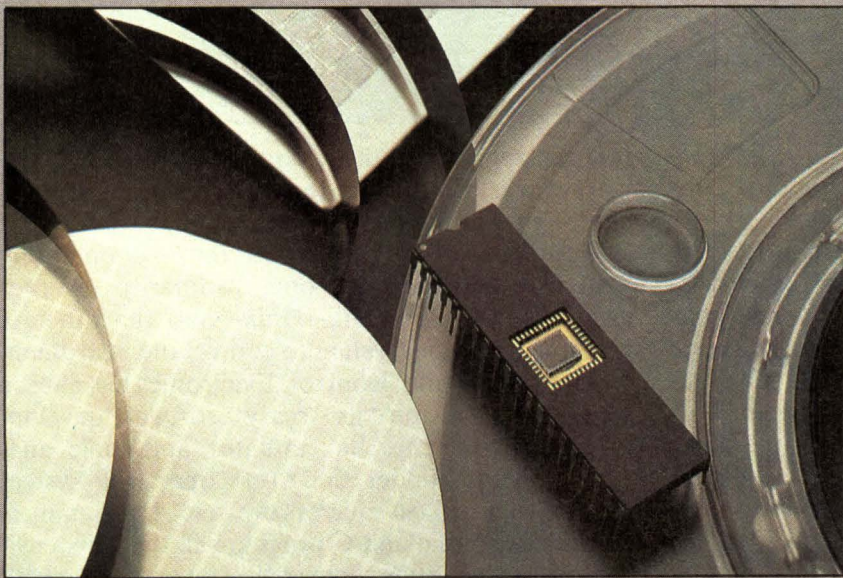

*Finished parts.
Getting them from
most design houses
can be touch and go.*

Designing chips on a standalone workstation can save you months of time and thousands of dollars. Trouble is, most design houses consider the job finished when they hand you a PG or Calma tape.

Not Matra Design Systems. At every stage of the design cycle, we offer CAE and IC design services that are second to none. But then we add something most other vendors don't: the finishing touch.

Once your design is complete—using our high-speed, 3 μ m CMOS family of 250-, 400-, 800- or 1200-gate arrays—we guarantee a fast turnaround for your prototypes. That means now you can not only complete your design in record time, you can go all the way from concept to silicon—fully tested and packaged parts, ready to use.

And if you're doing as little as two chip designs a year, you can't afford *not* to be using GateMark™ our exceptionally affordable CAE workstation. It offers the capabilities of large-scale systems, at prices that start as low as \$24,000. You can also run our CAE software on your own VAX. Either way, your development costs can be cut to the bone.

Plus our CMOS HAL/PAL™ automatic conversion tool allows you to merge one or more PALs on a single array.

For information on GateMark or our full range of design and fabrication services, contact: Matra Design Systems, 2840 San Tomas Expressway, Santa Clara, CA 95051; (408) 986-9000.

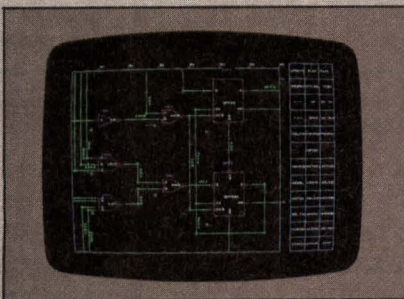

Interactive schematic editor accepts netlist text or logic input.

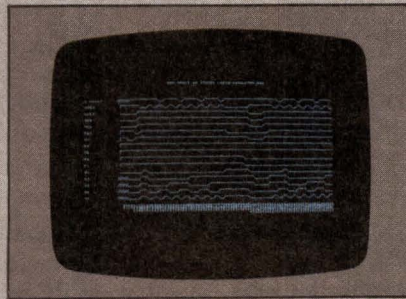

Logic simulator models circuit functioning without actual breadboarding.

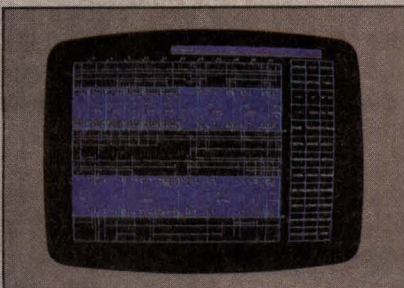

Layout editor automatically places and routes structured cells from our library.

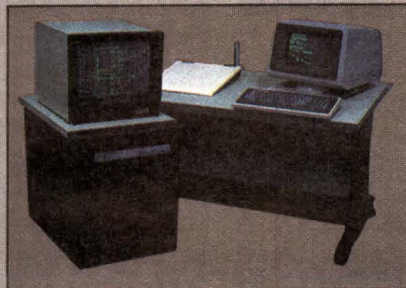

GateMark™ stand-alone CAE workstation includes complete software package.

PAL is a registered trademark of MMI.



MATRA
DESIGN SYSTEMS

CIRCLE 83



The Unix environment running on the VME/10 workstation from Motorola Semiconductor has been modified to work closely with the HDS 400 hardware station for realtime software debugging.

vendors' offerings focus on specific hardware configurations as well as the particular brand of Unix spoken.

Motorola has chosen Unix System V as the development environment for its ExorMACS multi-user system as well as its VME/10 standalone workstation. Bundled with this version is the source code debugger (SDB) high level language debugger familiar to users of the Unix operating system. This debugger displays high level language source statements concurrently with the disassembled object code and can provide a history of calling procedures so that errors can be traced back to the original calling routine. Users can set software breakpoints so that high level statements are executed one by one or as a range of statements. Enhancements to the original version also allow the HDS-400 in-circuit emulator to be used. As a result, the debugger can perform strictly as a software monitor like PSCOPE, or as a realtime debugger with hardware breakpoints.

Meanwhile, the other vendors have chosen to forsake the SDB and develop proprietary symbolic debuggers that are closely coupled to their in-circuit emulators. For example, Gould Design and Test Systems provides a C-based command interpreter on its 9516/9516S integration workstations. This symbolic debugger offers the same capabilities found on other realtime systems. It can link memory locations and registers with their source code counterparts, and complex breakpoints with several conditional trigger events. Its extensive program tracing monitors jumps and interrupts. The command interpreter lets users define macros with local and global variable declarations, and create compound and conditional functions. Users have full control over not only the target hardware (eg,

internal registers and memory), but also the 9516/9516S workstation, since the command language includes emulator specific commands as well.

Gould points out the need for two operating system environments: one, primarily a programming environment—Unix—and the other, a realtime operating system to control the instrumentation. Meanwhile, Kontron Electronics has chosen to use Unix Version 7 as strictly a software development environment. Its emulator and logic analyzers operate under the CP/M operating system running on a Z80 microprocessor. Programmers developing Pascal and C programs in the Unix environment (which runs concurrently on a separate 68000 microprocessor) access instrumentation resources by invoking a command that calls in the CP/M operating system. Thus, the KDS968 workstation can support two users doing software development on separate terminals while another user performs hardware development on the KDS968 itself.

The Genix version of Berkeley Unix 4.1 by National Semiconductor supports two-phase debugging. One phase enables Genix to be brought up on any target system for cross development. The debugging tools mainly involve bringing up the Genix kernel in the native machine code. Its NSX16 symbolic debugger handles cross development for targets with prototype hardware as well as with the DB16000 evaluation board and in-circuit emulators. To support large memory addresses, the symbolic debugger can insert breakpoints that trigger on either logical or absolute addresses. The debugger can also do program tracing whether segments reside in physical memory or on disk. To handle virtual addressing, a microprocessor development system must have the ability to tell where the physical addresses end and logical addresses begin. Thus, the 16081 memory

POWER BASE IN UNCHARTED TERRITORY

The growing demand for ultra-high performance, processor-based designs won't be satisfied by garden-variety microprocessors. There is another world to be explored where the possibilities are truly exciting. Where the opportunities are unlimited. It is the world of custom microprogramming — a domain where more functions can be implemented in less time, where software is less extensive and where your discoveries can be protected from prying eyes.

HILEVEL can guide you through that domain with the DS370, a firmware development system so superior that other systems cannot follow. Here is where flexible word length, memory emulation and custom microcode turn ordinary designers into creative pioneers. This is where software and hardware trails are intertwined, and

where the DS370's Graphic Performance and Timing Analysis, Selective Trace, Symbolic Debug, 16 triggering levels with 8 qualifiers each, and other features give you unprecedented power over microprogramming. See our power base today. Call for a personal demonstration: 1-800-HILEVEL; inside California 1-800-752-5215.

HILEVEL TECHNOLOGY, INC., Irvine Technology Center, 18902 Bardeen Way, Irvine, CA 92715; (714) 752-5215; TLX: 65-5316.

HILEVEL
TECHNOLOGY, INC.
See us at Southcon #1343

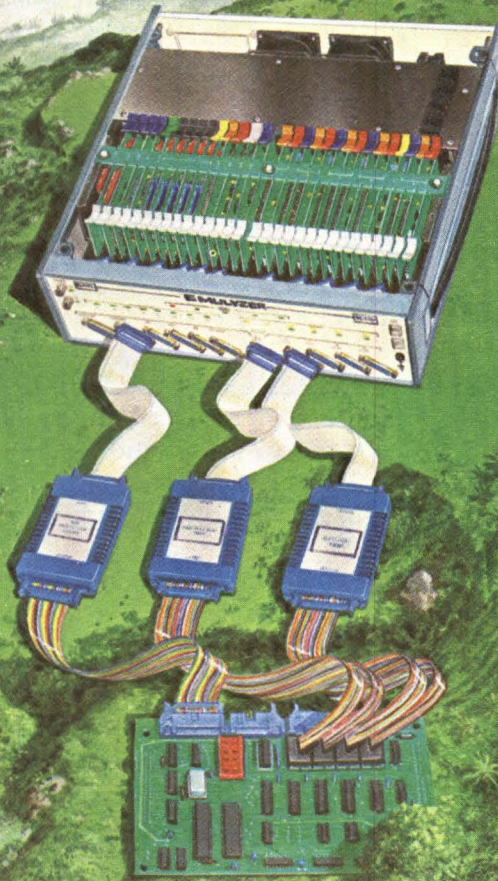

Circle 84 for Literature
Circle 153 for Demonstration

A. DAVIDSON

Integrating tools at Gould

According to Dave West, vice president of marketing for Gould Electronics, multiple processors (mostly of the 16- and 32-bit variety) are driving the development environment to networks of engineering workstations. "The biggest trend that we're starting to witness is multiprocessors," says West. Single-user development systems are being linked into networks while the minicomputer VAX-type environment is increasingly being used as a high powered node in such networks. While the mini can be used as a database manager, it also serves as a programming environment. In a network, the ability to port software tools from mini to workstations also becomes an issue.

In addition, the nature of the high level language compilers such as Pascal and C used in development and debugging goes beyond what would be required. "Most of the microprocessor-based systems that are being designed now are embedded systems," notes West.

Among other things, the compiler must generate more information in terms of symbols and labels that can be used in a debug environment, and the final code should be ROMable to fit with embedded systems.

To accommodate the trend toward multiple processors—often with quite different architectures and instruction sets—Gould believes that the same high level source code should be able to produce object code for a variety of processors. To accomplish this, the company has implemented machine-specific back ends to its compilers. "The front end is so that you can move from language to language, the back end is so that you can move from processor to processor," says West.

For the total development environment, Gould sees the need for two kinds of operating systems: one for programming and project management (ie, Unix), and another for realtime control of the instrumentation. But even at the instrumentation level, there is need for a high level user interface and command lan-

guages. At this level, the language of choice is C, which is used not only to control high speed multiprocessor operation, but also to monitor that data and then convert it into information that can be analyzed by the user.

With all the asynchronous events that happen among multiple processors in the target system, the processors must be tightly coupled over the instrument's emulation bus. The realtime operating system must then be able to vertically couple control and monitoring to the higher level languages. Gould does not see its role as providing specific analysis programs, a task which is best left to the user. But the tools to produce them are provided in the form of the human interface program (HIP) and the C command language which allows control of all hardware functions in the 9516 workstation. "It happens to be an emulation computer, but it's a computer," West notes. "That general purpose power is

needed for capturing, controlling, and analyzing data."

"You must be able to collect that data and control in real time, but also take that data and convert it into information the user can absorb. We went beyond the user's ability to absorb all of that data when we went from 8 to 16 bits," says West. Therefore, although the interaction between multiple processors takes place down at the hardware level, the software tools need to deal with it symbolically.

The development environment, then, has a vast task. It must preserve previous investments in tools and incorporate new ones, along with providing high level interfaces—from the minicomputer world to the detailed interaction between multiple processors. The processors in the target system may be tightly or loosely coupled. It is imperative, however, that their instrumentation be tightly coupled in a horizontal sense (among one another), and also in a vertical sense. This is to ensure that the data they generate can be manipulated and analyzed to increase the productivity of system development.

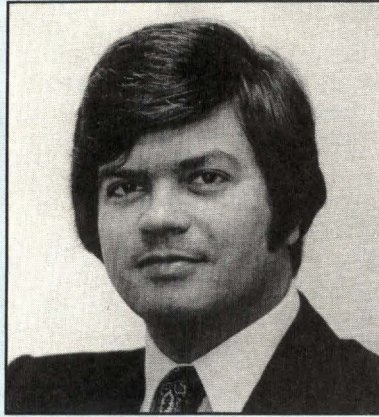

Dave West of Gould Electronics

management unit includes registers designed to store breakpoint information and to support program traces.

Zilog Inc's (Campbell, Calif) Z-Lab 8000 uses the company's Zeus implementation of Unix as its operating system, and therefore has all of the popular programming languages available, as well as the Unix utilities. It does not yet have a source code debugging facility. The central processor is based on the Z8000, and will support up to 16 users working concurrently on software development or documentation. It can also communicate with other Zilog systems via the company's Z-Net implementation of Ethernet.

The company provides a line of standalone emulators for the chips it builds, which communicate

with a host computer via an RS-232 link. These provide information on CPU registers, and the address bus state. They also disassemble object code as necessary and provide access for a logic analyzer.

One source, several objects

Cross assemblers, which run on minicomputers, have been available for many years from both development system makers and independent software houses. In the minicomputer field, Whitesmiths, Ltd (Concord, Mass) has a relatively complete line. Avocet Systems, Inc (Dover, Del) supports most popular microprocessors with cross assemblers that run under CP/M and CP/M-86.

More recently, cross compilers that generate object code for almost any microcomputer have

the technology is...



the image
speaks
for itself

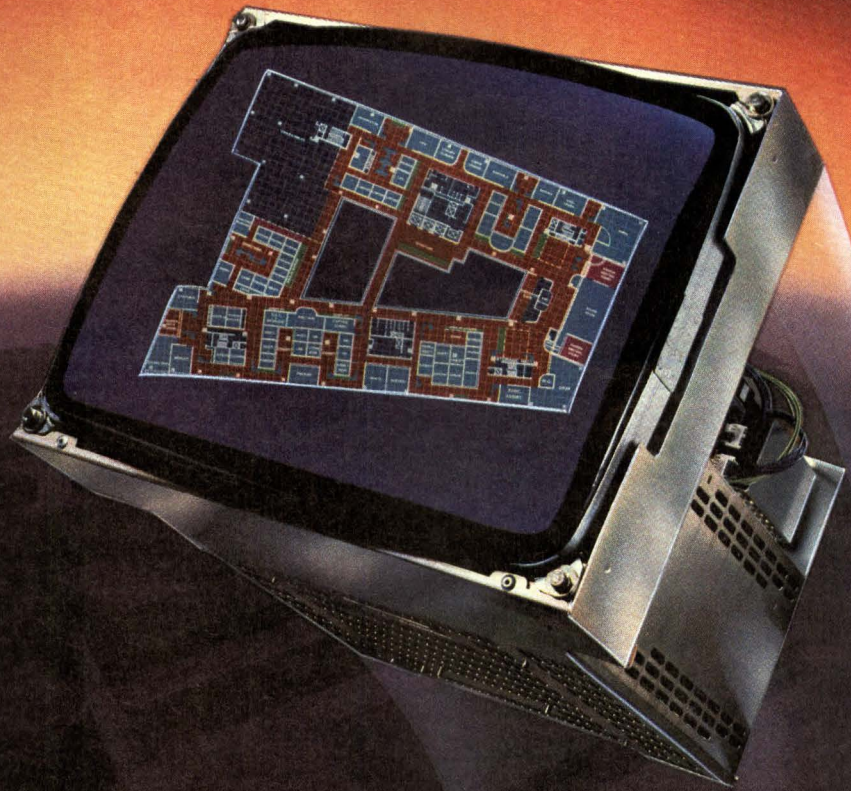

Hitachi introduces the new standard in Hi-Resolution. That standard is embodied in our new HM-4619 RGB Color Monitor.

The HM-4619 delivers flicker-free images with 1280 x 1024 resolution at 60 Hz. Hitachi tube technology leadership has created a new in-line gun delivering high brightness with sharper focus. All of this is enhanced by our Digital Dynamic Convergence™ of 0.1/0.3 mm.

The Hitachi line of RGB Color Monitors is rapidly becoming the clear choice of OEM's throughout the world. We feel our new, top of the line, HM-4619 is the unit which will set the standard by which all other color monitors will be judged.

- New In-Line Gun with Hi-Brightness and Sharp Focus
- 1280 x 1024 Resolution at 60 Hz
- 0.1/0.3 mm Misconvergence
- 100 MHz Video Bandwidth
- Compact Design
- Cost Effective State of the Art Technology Plus the Strength of Hitachi Worldwide Support



The Image Speaks for Itself

Hitachi America, Ltd.
59 Route 17S, Allendale, NJ 07401
(201) 825-8000
3540 Arden Road, Hayward, CA 94545
(415) 783-8400
Hitachi Europe, Ltd., Lee House (10th Floor)
London Wall, London EC245AS
(01) 606-7831
Hitachi Denshi Canada, Ltd. 65 Melford Drive
Scarborough Ontario, Canada M1B 2G6
(416) 299-5900

H-I[®] Hitachi America, Ltd.
computer graphic courtesy ARIEL Computer Productions, Toronto, Canada



The 64000 workstation from Hewlett-Packard uses a dedicated internal bus to handle peripherals, such as emulators and analyzers, while the control processor and memory reside on a separate bus. This results in increased throughput and realtime measurements.

become common. While these tools speed the programming process, they do not address the problem of debugging the system being developed. Few programs run right the first time, and hardware design changes can start the whole cycle over again.

Simulation on minicomputers or mainframes, such as the package available from Systems & Software, Inc (Costa Mesa, Calif), is a powerful tool for analyzing a circuit before it is built. Its usefulness, however, depends on how accurately it models the real circuit. Small variations from nominal parameters on individual chips can add up to major problems in an actual design. Without a careful check of the program in an actual circuit (which takes more setup and analysis time), simulation is not a sure-fire development technique.

A high level debugger saves information from the high level source code compiler, and associates it with particular locations in the object code. These are available from all of the major development system manufacturers such as Intel, Hewlett-Packard (Palo Alto, Calif), Tektronix, and Gould, as well as from independent software vendors, such as Intermetrics (Cambridge, Mass), Boston Systems Office (Waltham, Mass), and Concurrent Sciences, Inc (Moscow, Id). A particular location in memory will contain a variable, for instance, which is part of a particular procedure in the source. If there is a problem, the designer can then examine the source code and the contents of the defined variables at the time of the difficulty, and thus find errors in logic or hardware problems more easily.

To make this approach work, the compiler must save the symbol table, containing the names of the procedures and variables that it creates while pro-

cessing the source. It must then pass this information on, so that the debugger can associate the names with memory locations, and retrieve the source when necessary. The two must be written together, and be smart enough to know the type of hardware being tested. In addition, the debugger must know about the development system's resources, and the system, in turn, should be built to make the debugger's job easier. Intermetrics and Gould/Millennium (Cupertino, Calif), have jointly developed such a system, each company applying its expertise to one section of the problem.

These tools almost require the power and storage of a medium to large minicomputer, and most of the complete systems offered run on DEC or vendor-supplied machines. Tektronix and Digital Equipment Corp (Maynard, Mass), for instance, have cooperated to offer a system which runs on the VAX and controls the system under test through a Tektronix emulator. Softscope, from Concurrent Sciences, runs under VMS on the VAX or under VM/CMS on IBM machines. The announcement of the IBM PC/370, which uses the latter operating system, indicates that many more sophisticated tools, which would otherwise require a mainframe, will be available to the designer at a reasonable cost relatively soon.

Forth and Forth-like development systems, such as those available from Forth, Inc (Hermosa Beach, Calif), Infosphere (Portland, Ore) (see Evan Solley's article, "Simplify programming of realtime systems," p 193), and Inner Access (Belmont, Calif) are a curious cross between high and low level languages. The language has been described as a structured assembler for a virtual machine. It contains the control structures and the

Let Fluke rescue you from the landslide of μ p-board failures.

Four billion microprocessors will be built into countless products this year. We're filling the world with micro-systems. But *how* can we test and service them all?

Fluke's 9010A Troubleshooter puts some fast, simple answers at your fingertips. It's the first tester so easy to use, you'll start

testing the first day.

Fluke has pre-programmed the 9010A to find most common faults automatically. Press a single key and it checks for Bus, ROM, RAM, or I/O faults, displaying clear diagnostic messages. For faults beyond the bus, our smart probe uses both stimulus and measurement to

quickly track failures to the node.

With support for 32 types of microprocessors, the 9010A will test almost any product. Merely plug the correct interface pod into the microprocessor's socket and take control of the unit under test.

You can easily customize any 9010A test right at the keyboard. Or, for extensive programming, use our new 9010A off-line Language Compiler with a personal computer. It makes programming easier and up to 3 times faster!

Don't get buried in the PCB landslide. For less than \$5,000 you can own a Fluke 9010A, complete and ready for testing today. For more information, contact your local Fluke representative or call 800-426-0361.



Now write 9010A software off-line with our new Language Compiler and popular personal computers. It's a convenient tool that makes programming fast and easy.

IN THE U.S. AND NON-EUROPEAN COUNTRIES:
John Fluke Mfg. Co., Inc.
P.O. Box C9090, M/S 250C
Everett, WA 98206
(206) 356-5400, Tlx: 152662

IN EUROPE:
Fluke (Holland) B.V.
P.O. Box 5053, 5004 EB
Tilburg, The Netherlands
(013) 673973, Tlx: 52237

FLUKE[®]

9010A Micro-System Troubleshooter.

Copyright © 1983, John Fluke Mfg. Co., Inc.
All rights reserved.

For technical data circle number **86**

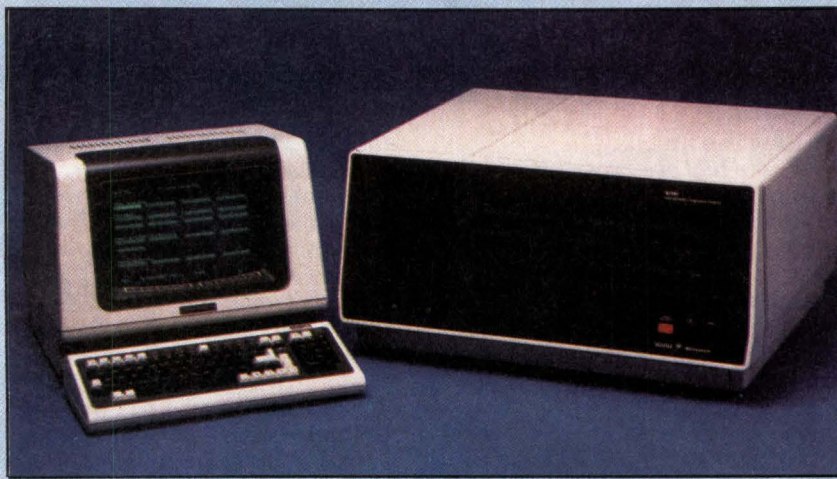

The 9516S microsystem integration station from Gould Design and Test Systems includes a C-based command interpreter. This allows users to supplement menu functions with their own defined macro commands.

ability to create block structures (procedures and functions) typical of modern languages such as Pascal, yet it allows direct manipulation of memory and peripherals. Its greatest advantage is compactness. Most of the code consists of 16-bit pointers, and the primitive code sections can be relatively small. In addition, once the code has been debugged at the highest level, utilities exist to strip out names and header information and produce code that can be put into ROM.

Two companies, Hilevel Technology, Inc (Irvine, Calif) (see "Microprogramming versus microprocessors," by Bjorn Dahlberg and Wendy Kane Wanderman, p 171), and Step Engineering (Sunnyvale, Calif), provide systems for developing microprogrammed processors using TTL or ECL bit-slice devices. Both companies provide the equivalent of an assembler and a software emulator, to relieve the designer of the tedious job of hand coding that custom bit-slice designs had previously demanded.

Microprogramming has been common in the development of large systems, where high labor costs could be justified on the basis of the very high final system cost. Embedded systems and controllers are very cost sensitive, however, and it has heretofore been more practical to use standard chips and software for most applications.

Technology and tools for microprogramming are still five or so years behind those available for microprocessor development, but they are progressing along the normal curve for the industry. Their future development, along with the advances expected in chip fabrication and VLSI design (eg, the "Silicon Compiler") will give the designer new capabilities and the power to build powerful, cost-effective products "on demand."

Performance analysis

Programmers now have the tools to increase performance by recoding with high level languages as well as assembly language. As with high level symbolic debuggers, the latest generation of hardware development tools display statement numbers and

labels from the original source code statements in addition to the contents at the physical addresses. Furthermore, such tools can examine execution times of individual source code statements as well as compare procedures against each other. Development system vendors active in this area include Gould Design and Test Systems, Hewlett-Packard, Intel, Motorola Semiconductor, National Semiconductor, and Tektronix.

The importance of measuring high level source code performance increases as application programs for 16- and 32-bit microprocessors move away from assembly language and toward languages like Pascal and C. No longer will there be a one-to-one relationship between source code and resultant object code as was the case with assembly language programming for 8-bit microprocessors. High level language compilers generate many lines of object code for each source code statement, making automated analysis tools mandatory.

Past efforts at performance analysis involved manually sifting through symbol maps and code listings to translate physical locations along with the original source code variables. This approach proves inadequate, however, for large application programs developed for 16- and 32-bit microprocessors that can easily exceed 100,000 lines of code. Furthermore, the complex instruction sets for 16- and 32-bit microprocessors make it more difficult to increase performance by programming in assembly language. Programmers must match instructions with the correct addressing scheme and word format (eg, integer, real, and floating point) with different combinations yielding different performance levels.

On the other hand, high level language compilers have reached a point where the performance penalty between compiled code and the assembly equivalent is small. For example, the PL/M compiler for Intel processors typically produces code 40 percent larger than the assembled equivalent, according to an experienced PL/M programmer. Optimizing compilers take advantage of special instructions and

FORM FACTOR

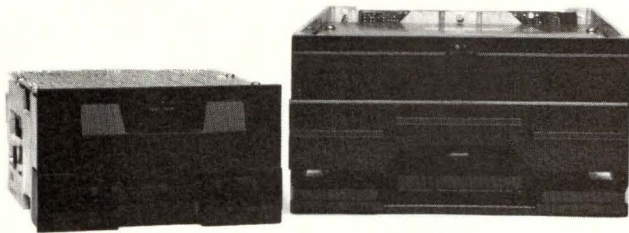

In the data storage business, some things change faster than others. And some things change faster than they should. When it comes to capacity, performance, reliability, and cost efficiency, the rule is clear: "the faster the better." But when it comes to changing the physical dimensions of drives, "not so fast" makes better sense. After all, as an OEM, you're looking for as much system continuity as possible.

IOMEGA's Alpha 10 And Beta 5: True To Form—And Reform.

What IOMEGA's disk drives—the 10 Mbyte Alpha 10 and 5 Mbyte Beta 5—share in common with many others on the market is *form factor*. The Alpha 10 matches the dimensions of all standard 8-inch drives. And the Beta 5 does the same for standard 5¼'s.

What the Alpha 10 and Beta 5 *do not* share with anyone else is a new technology that allows us to offer *mass storage capacity on a flexible medium*, utilizing the popular cartridge format. We call it our *reform factor*. Because, with 10 and 5 Mbytes for starters, what we've done, quite literally, is re-form the previous notions about how much data could be put on a flexible disk.

REFORM FACTOR



More Than More Storage.

IOMEGA's design features—such as non-contact head-to-disk interface, high-linear bit densities, and enclosed servo control of the head positioning—result not only in *more* flexible disk capacity, but in *more* performance, reliability, versatility and economy as well.

And it results in *more* ways to use that storage, too. IOMEGA's greater reliability makes the Alpha 10 and Beta 5 perfect for primary mass storage. And their flexible, low-cost cartridge design makes them naturals for back-up and archival storage as well.

More capacity. More performance. More reliability. More versatility. More economy. *And no more waiting.* Because IOMEGA is delivering both the Alpha 10 and Beta 5 in OEM quantities *right now.*

Call today for *more* information.



IOMEGA Corporation, 4646 South 1500 West
Ogden, Utah 84403 (801) 399-2171

Sales Offices: San Jose, CA (408) 263-4476; Coral Springs, FL (305) 755-1060; Woburn, MA (617) 933-2000; Dallas, TX (214) 458-2534; Brookfield, WI (414) 782-5229.

```

PASCAL_CONFIGURATION Default Configuration (default)
Please type in a title for your ICS source file.
program.is
PASCAL_CONFIGURATION program.is

HARDWARE_CONFIGURATION 8086 (default)
Which of the following terms best describes the type of processor(s)
you are using?
1) 8086
2) 8088
3) 8086 with 8087
4) 8088 with 8087
Select by entering a number from 1 to 4.
1
HARDWARE_CONFIGURATION 8086

INSTRUCTIONS_ROM [00060H,07FFFH] (default)
CONSTANTS_ROM [08000H,08FFFH] (default)
GLOBAL_VAR_RAM [09000H,0D7FFH] (default)
HEAP_STACK_RAM [0D000H,0FFFFH] (default)
These directives assign address ranges to the different types of code in your
program.
You can:
1) approve these allocations
2) change INSTRUCTIONS_ROM

```

The Language Oriented Development System (LANDS) from Tektronix supports high level language development and debugging on DEC VAX-11 computers or their own 8540/8560 development systems.

addressing schemes that speed up execution while avoiding possible exceptions.

Performance analysis reduces potential penalties even further by highlighting which source code procedures take the longest to execute. This approach follows the programming truism stating that "80 percent of the execution time involves only 20 percent of the code." Identifying performance bottlenecks such as I/O processing or interrupt handling gives programmers the option of recoding these portions in assembly language for faster execution; this leaves the remainder of the compiled code unchanged. Programmers were often faced with the choice of either all assembly languages or all high level languages for the entire project prior to the availability of these tools which pinpoint inefficient code.

The latest generation of development tools can examine compiled code one source code statement at a time, or an entire range of statements. In addition, execution times of several procedures can be compared to detect possible trends. On most systems, programmers can view the source code statement and the resultant object code simultaneously. This enables users to manipulate either the contents of physical locations or the original source code variables and constants.

The tools required for high level language performance analysis are remarkably similar to those used for assembly programming: in-circuit emulators, state analyzers, and timing analyzers. Rather than displaying the contents stored at physical addresses, however, state analyzers now show source code variables and constants. Instead of single-stepping through object code one machine cycle at a time, timing analyzers now step through high level language programs one statement at a time, or through an entire procedure. Rather than setting breakpoints and triggers on fixed addresses

and actual values, in-circuit emulators now use statement numbers and variable names.

Software monitors like PSCOPE also perform many of the same functions as their hardware siblings, but are limited in performance since they rely on software breakpoints embedded in the object code. Once triggered, control of the program returns to the host operating system for further action. In contrast, in-circuit emulators employ hardware breakpoints to monitor activity without affecting the object code execution. This becomes important in systems where even minimal delays of a few microseconds can affect the overall performance of the system under test.

Prime examples of this class of tools are the 64620S software/state analyzer and 64310A software performance analyzer from Hewlett-Packard. The software/state analyzer shows relative execution times by user-assigned events or a state distribution of different program blocks. It also provides extensive program tracing capability for either high level language or assembly language programs. Going beyond one-shot execution measurements, the software performance analyzer makes long-term measurements to detect possible trends in program execution. This analyzer is also able to measure the number of accesses to a specified code segment, the number of transfers between code segments, and memory accesses by several code segments. The 9516/9516S workstation from Gould Design and Test Systems matches closely the same hardware scheme. Motorola provides similar functionality with its combination of an HCD 400 emulator with the state bus analyzer. Tektronix takes a similar tack with its 85610 integration station with trigger trace analyzer.

Particularly useful during the debugging process, the HP64620S software/state analyzer can gauge execution speeds once individual code segments have been compiled and linked. The analyzer is most useful when coupled with an in-circuit emulator for interactive measurements. As many as 120 input channels (or as few as 20) are used to collect all logic states, or selected states within a range of narrowly defined data types. Realtime counting, either by event or time, adds another analysis dimension.

Controlling these functions is a complex triggering scheme that allows up to eight patterns connected by logical OR operations. The trigger patterns can include values, ranges, "don't care" terms and NOT terms. These trigger terms can always be enabled, either by a 15-term sequencer, or in conjunction with another analyzer or emulation module for use in multiple processor systems.

Especially useful for tracking glitches that occur infrequently, the sequencer specifies a state sequence that must occur before it can trigger, count, or store events—much in the manner of a hardware

THE MAINFRAME THAT CAN BE IN 1000 PLACES AT THE SAME TIME.

CADMUS 9000. The Distributed UNIX™ Mainframe.

This is the system with mainframe power in a single network node. The mainframe that gets stronger with each node added. And it gives any individual user transparent access to any file, program, device or peripheral on the network. In short, the Cadmus 9000 is the alternative to large minicomputers in computationally intense applications.

The operating system is pure UNIX with all the resources of UNIX System V and the Berkeley enhancements. And the system's C-Compiler is uniquely optimized for efficiency on our 32-bit virtual memory processor.

Networking through our unique UNISON™ software provides the full resources of the network from all computational nodes with network-wide virtual memory demand paging. And the interprocessor bus is connected by a 10 Mbit Ethernet™ or 50 Mbit fiber optic LAN.

In addition, comprehensive graphics, development and decision support tools facilitate graphics



applications in a windowed, multiple process environment.

Finally, we support every Cadmus 9000 with Thunderbolt™ service that puts an engineer at your door anywhere in the country within 24 hours. Guaranteed.

To find out more about the most powerful distributed UNIX system in the world, contact Cadmus Computer Systems at 617-453-2899. Or mail the coupon.

CADMUS
COMPUTER SYSTEMS

Please send me product literature on the Cadmus 9000.

Cadmus Computer Systems, Inc.

600 Suffolk Street, Lowell, MA 01854

NAME _____

TITLE _____

COMPANY _____

ADDRESS _____

CITY _____ STATE _____ ZIP _____

Cadmus, Cadmus 9000 and UNISON are trademarks of Cadmus Computer Systems, Inc.

Thunderbolt is a service mark of Cadmus Computer Systems, Inc. UNIX is a trademark and service mark of Bell Laboratories.

Q-Bus is a trademark of Digital Equipment Corporation.

Ethernet is a trademark of Xerox Corporation. Cadmus products are available in Europe through PCS GmbH Munich, West Germany (089) 678040.

logic analyzer. These sequences can be set to trigger after one specified state follows another, or after a state occurs a specified number of times. Up to 15 such events can be monitored with ranges or values corresponding to program addresses or other information stored in the symbol maps. Graphics display of the acquired data takes the form of either a histogram that measures the percentage of execution time used by each of the events, or a frequency distribution of events that displays the sequence of their occurrence.

Histograms and tables play a major role in the 64310A performance analyzer's display of activity among several object code modules. The histogram gives programmers an easy-to-interpret bar graph representation of program or memory activity, while tables show the actual data that serves as a basis for the histogram. In addition, users can switch from absolute to relative measurements to compare time and occurrence measurements between several object modules or against the entire program.

Data is continuously accumulated and displayed in the histogram format. In fact, this information can be used for further processing. For example, users can glean such statistical information as means, standard deviations, and confidence levels to gauge the accuracy of the activity measurements.

The bigger picture

Going beyond merely measuring one-time execution of selected object code modules, the software performance analyzer allows programmers to monitor the time distribution of executing object modules to see if they are performing within expected bounds. For example, the analyzer can tell a user that module A takes 50 to 60 μ s to execute 36 percent of the time. Furthermore, users can include (or exclude) in the measurements the time involved interacting with other code segments or external inputs to spot best-case and worst-case conditions.

If programmers are concerned with the interaction between two object modules, time interval measurements can measure the activity between them (eg, the time interval between module A and module B ranges between 6.5 and 6.6 μ s). Likewise, users measure the interval between the time a selected code segment is exited and the time it is entered again to judge the intensity of demand. Overall software traffic patterns are detected by measuring the number of transfers between selected code segments.

Other vendors also plan on using graphic displays to highlight performance measurements. For example, Gould Design and Test Systems provides an application package to display program activity comparisons as well as memory activity. Motorola provides histogram displays as part of its state bus analyzer module. Often linked with its HCD 400 in-

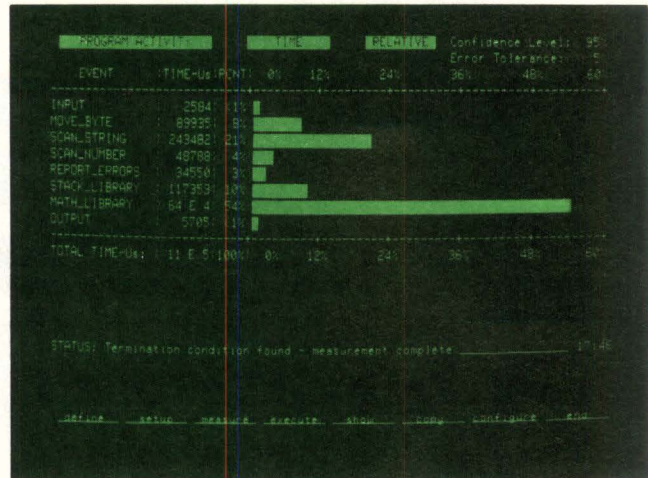

Histogram displays are part of the software analysis package offered on Hewlett-Packard's 64000 development system. The program activity measurements display actual execution times for several modules as well as their relative performance against each other.

circuit emulator, the analyzer displays relative performance for both program and memory activity.

More important than vendor-defined measurement routines is the ability for users to write their own measurement and display routines. Gould Design and Test Systems takes the attitude that vendors cannot conceive of all possible measurements that users might need to accurately gauge the performance of their products. Extensive command languages provided with the development systems give users the tools needed to design custom measurement routines as well as displays.

Customers could quickly develop such packages since the development systems already have command languages that control the hardware. As an illustration, Gould includes a C-based command language for its 9516S emulation system. This language has the hooks needed to acquire such information as memory transfers from the emulators, monitor state, or timing analyzers, and to display the results on the CRT screen. Tektronix includes such capabilities for its 8500 development workstations through its Pascal Debug package. Motorola operates a Unix-based environment with enhanced C-shell to offer similar capabilities on its ExorMACS and VME/10 systems.

Perhaps it is not important to provide such detailed information since the state of software management is such that specifications cannot be drawn to such minute detail. Robert Freund, software manager for National Semiconductor, believes that such measurements as relative performance comparisons give a global view, but do not provide any added insights to pinpoint problems within the code itself. Software management tools have yet to reach the point where specific code segments have an expected execution time, so measurements focused on comparing the two are, then, often subject to wide interpretation, according to Freund.

SYSTEM 2100 – Intech's newest Logic Analyzer searches microcode with New Power.

Multiple clocking capability—lots of input channels—good resolution on data captured—Sure, we know these features are all needed. That's why our SYSTEM 2100 has up to eight external clocking inputs—up to 64 data capturing channels and recording frequencies to 100/400 MHz. But . . . these features are only part of the microcode troubleshooting story. The most important feature of a Logic Analyzer is TRIGGERING and its ability to trace through the most complex program or multiprocessor system with ease and accuracy. So . . . that's what we've included in our new SYSTEM 2100 Logic Analyzer.

Advanced Triggering—Sophisticated μ P Debug Tool

You can select the most sophisticated tracing path through your Logic by specifying up to 64 instructions . . . each with "BRANCHING," "OR," "TIME-OUT," or "RESTART" functions with complete flexibility. Yes . . . you're not limited to a specific tracing routine dictated by the Logic Analyzer. We can follow your μ P's operation wherever it goes. And, you can specify up to 128 trigger words—the most extensive capability available today. And yet, we've done all this without making it impossible to use.

Simple Keyboard—Easy Operation

With our unimposing keyboard (simple to use) and self-prompting setup menus, it's easy to control the tests you want to make. With fewer controls, the SYSTEM 2100 makes more of the decisions. And you can view the data in "STATE," "TIMING," and "DISASSEMBLED CODE" by pressing just one button. Or access our new mass storage drive for even greater capability.

Mass Storage—Stringy Floppy*

Even with advanced triggering and simpler keyboard operation, we haven't neglected other features. Our new STRINGY FLOPPY cassette handles mass data storage and disassembler software. Or extensive tracing and triggering controls for easy recall. And, with our STRINGY FLOPPY you can even change setups and capture data when you're not available. Or use it to handle several independent tests . . . each requiring a different setup.

I/O Interface—Easy Control

The SYSTEM 2100 communicates easily with IEEE-488 and RS232C. And you can use it with a modem to handle remote diagnostics. Or use it with a printer to allow later evaluation of captured data, an excellent

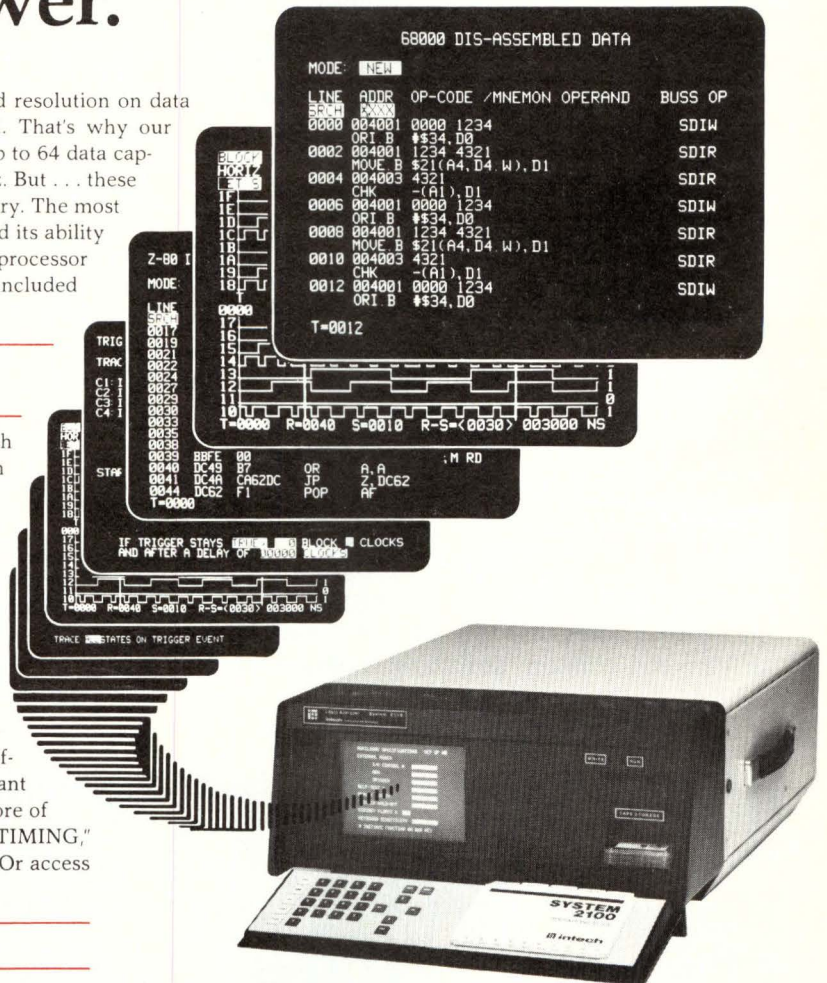

means of troubleshooting intermittants. A time of day clock/calendar lets you know when the incident occurred.

Modularity—For Today and Tomorrow

And with our modular approach you can have just the features you need today without jeopardizing tomorrow. When you move up in μ P or system complexity . . . so can the SYSTEM 2100. Just plug in boards (without tearing the unit apart) to increase your troubleshooting capability. Our plug-ins include: Higher resolution (400 MHz); more channels (up to 64); Disassemblers like Z80 and 68000; different probing options with 70 to 100 MHz bandwidth; printer outputs; and more. And Best of All . . . the price fits today's budgets.

Get The Facts

YES . . . Our New SYSTEM 2100 beats them all. Fill out the coupon or circle the Bingo Card and we'll send you our FREE Buyer's Guide to help you make the selection. OR . . . Better yet, give us a call at (408) 727-0500 x269 and ask for a Demonstration.

intech
Instruments Division

282 Brokaw Road, Santa Clara, CA 95050 (408) 727-0500 x269



Please send me a copy of your FREE Logic Analyzer Buyer's Guide.

Name _____
Title _____
Company _____
Address _____
City _____
State _____ Zip _____
Telephone _____

Mail to:
Intech Instruments Division 282 Brokaw Rd., Santa Clara, CA 95050

*Stringy Floppy is a Registered Trademark of Exatron Corp.

Whatever the detail of the measurements provided, users will still need to have the option of modifying programs at the object code level or the original high level language source. All vendors also provide the ability to insert high level patch files for debugging with the option to replace them when production begins. This issue is not so much a programmer's dilemma, but an engineering management decision concerning standards.

Where to optimize

Of critical importance is the ability to document changes during a product's life cycle. Tools such as the Source Code Control System on Unix-based development systems usually track revisions to source code only. Object-code patches to speed execution or fix problems often fall between the cracks in such an environment. They fail to get documented during the revision process, and knowledge of such fixes vanishes when the engineer leaves the company.

Many vendors recommend that customers implement standards for their respective projects, emphasizing changes to source programs only. Mike Haggerty, software development manager with Motorola, notes that this may be the only means to effectively contain software maintenance costs, which usually comprise almost 80 percent of the effort during a project's typical five-year life cycle.

Meanwhile, assembly language runtime libraries offer a compromise between the needs for documentation and increased system performance. Previously used to handle common realtime routines (eg, I/O processing), such libraries can easily be created as part of software performance analysis. In fact, Tektronix provides an Integration Control System that can link runtime libraries at the same time that such hardware parameters as memory ranges and interrupt handling are specified.

Such tools will be especially effective for designers using off-the-shelf single-board computers and peripherals. With the hardware architecture already specified, designers can only increase performance by ensuring that the software has few bottlenecks. The ability to closely monitor compiled object code and make necessary changes at the source code, or with assembly language routines, makes software performance analysis a key tool for the future.

Please rate the value of this article to you by circling the appropriate number in the "Editorial Score Box" on the Inquiry Card.

High 713

Average 714

Low 715

AUTOMATED GOOSE.

AM84, THE AUTOMATED MFG. CONFERENCE

GREENVILLE, S.C. MARCH 19-22

At the workplace of the 21st Century, you'll experience the equipment and techniques of the "now" future.

AM84 will demystify the technology that's producing the greatest changes in the workplace since the Industrial Revolution.

Fittingly, AM84 will be held in South Carolina, where worker productivity

rates are among the nation's highest, one example of why, for business, South Carolina is pure gold.

Call today for complete details on AM84.

Conference:
(803) 242-3170.

Exhibition:
(803) 233-2562.

Or write: P.O. Box 5823,
Greenville, S.C. 29606. 

South Carolina

© 1983 SC SDB

CalComp Digitizers for Applications of All Types

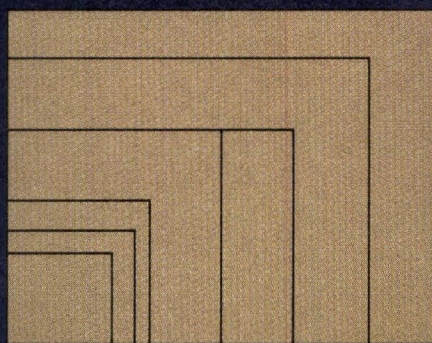
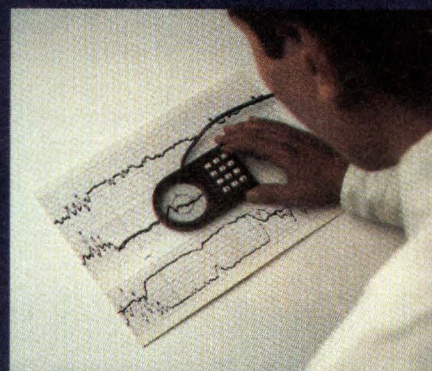
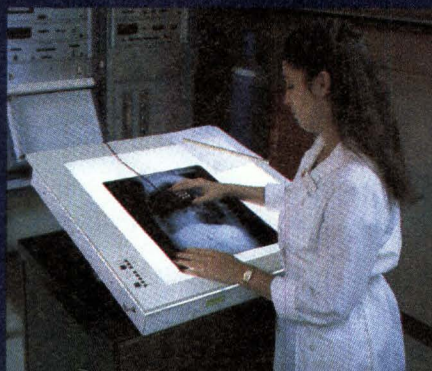
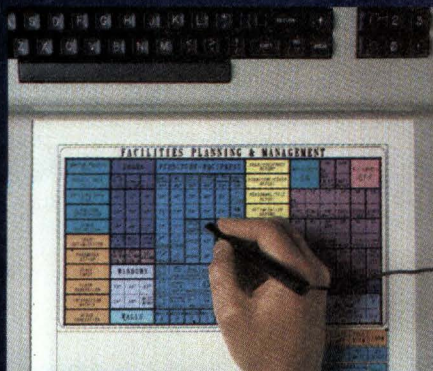

For more than 20 years, CalComp has been known for its broad range of plotters. What may not be as well known is that CalComp also produces a full line of digitizers.

Digitizers present a whole new world of data entry. Replacing the traditional T-square and ruler in drafting applications, digitizers let you input coordinate locations or dimensions, thereby letting your computer see what you draw.

Today, throughout the world, you'll find CalComp digitizers acting as a computer's eyes for varied applications such as:

- Tracking architectural building design details
- Charting utility maps and pipelines
- Measuring tumors and quantifying electrocardiograms
- Preparing isometric drawings

And, hundreds of other innovative time saving, money saving applications.

As you trace or draw on a digitizer — which is an electronically sensitized grid board — your computer captures each point accurately and stores it.

CalComp Digitizer active surface sizes range from 298mm (11.7 inch) square to 1524 x 1188mm (60 x 44 inch).

The Complete Range

CalComp's full line of digitizers, from the smallest to the largest, in standard surfaces, backlighted tables and even rear-projected models, is becoming recognized as the worldwide performance leader.

The type of graphic data being captured helps you decide the size and type of CalComp digitizer that's best for you.

The Small One

The compact, durable CalComp 2000 Series is ideal for OEMs, systems integrators and personal computer uses where low cost cursor control and menu selections are needed. It's single pen or 4-button cursor replaces both a keyboard and a joystick.

This 298mm (11.7 inch) square digitizer is plug compatible with most digitizers on the market and features a resolution of 0.127mm (200 lines per inch) with precision accuracy of $\pm 0.635\text{mm}$ (0.025 inch).

The Powerful One

The versatile, sophisticated CalComp 9000 Series is available in a range of sizes from 305 x 305mm (12 x 12 inch) to 1524 x 1188mm (60 x 44 inch) in solid and backlighted surfaces. Rear projected surfaces are available in special sizes.

The high precision 9000 Series has an accuracy of $\pm 0.263\text{mm}$ (0.0105 inch) with resolution of 40 lines per mm (1000 lines per inch), incorporating the latest technology in surface stability.

The powerful 9000 Series utilizes microprocessor technology while providing maximum operation flexibility, accuracy, and multiple interfaces with simultaneous operation.

For complete information call or write: CalComp, 2411 W. La Palma Ave., P.O. Box 3250, Anaheim, CA 92803. In continental U.S., except California, call (800) 556-1234, ext 156. In California call (800) 441-2345, ext. 156.

CALCOMP
A Sanders Graphics Company
 **SANDERS**

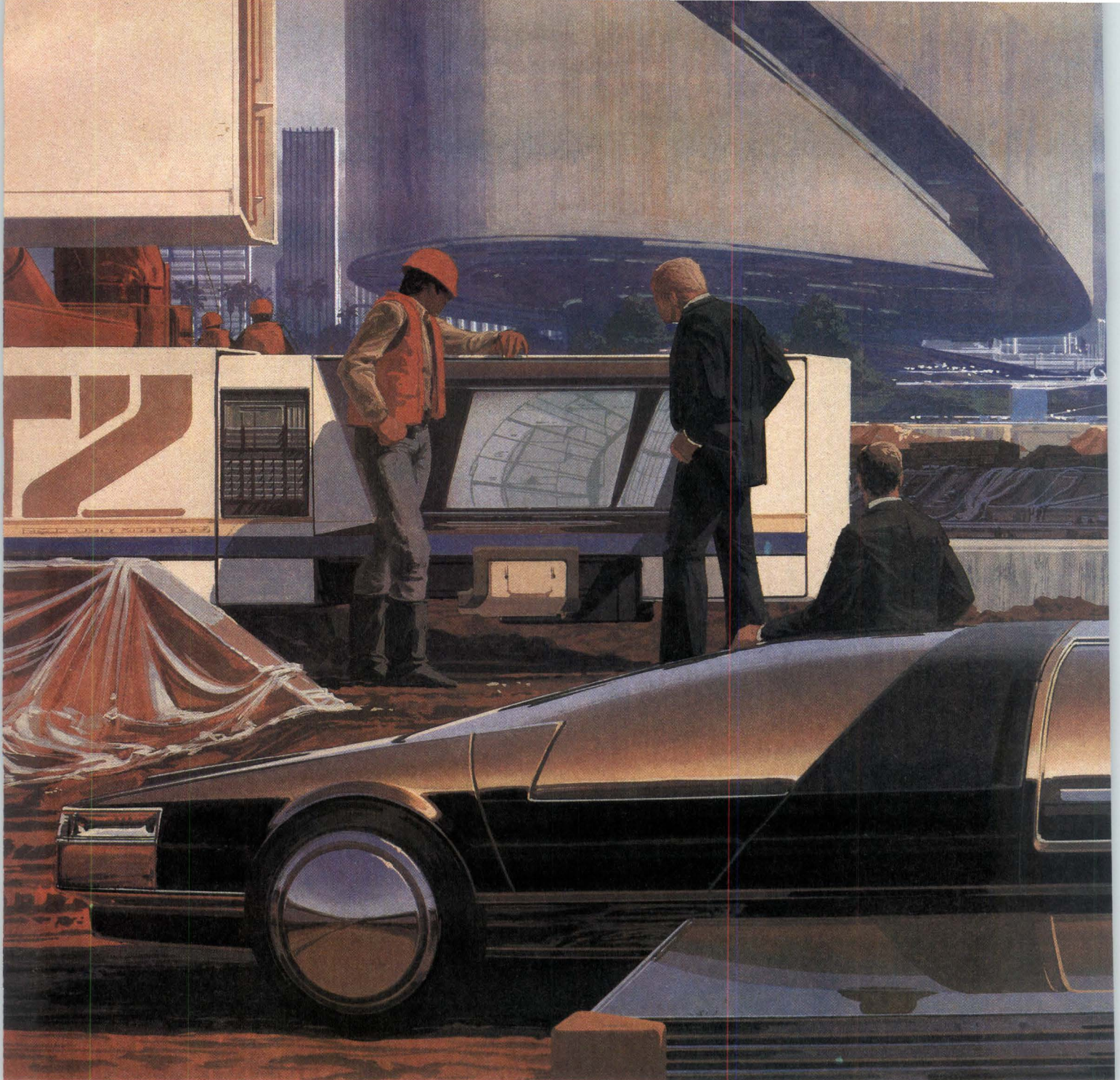

TOMORROW'S CAD MONITOR...



Powerful new computer graphic systems, in the hands of imaginative designers, are changing the world we live in. Automobiles, buildings, bridges and aircraft are just some of the applications for computer-aided engineering.

High resolution raster graphic CAD/CAM systems are the most versatile of these new tools, and Conrac's new Model 7300 is the color monitor designed specifically for those systems. Over 1000 non-interlaced lines of resolution (65 kHz scan rate, 60 Hz refresh) and a pixel rise time of less than 5 nanoseconds, gives you a completely flicker-free display with clarity and realism you've never seen before. Operators will enjoy working comfortably with this monitor all day long. The 7300 has permanent convergence and quiet operation—because it doesn't need a cooling fan.

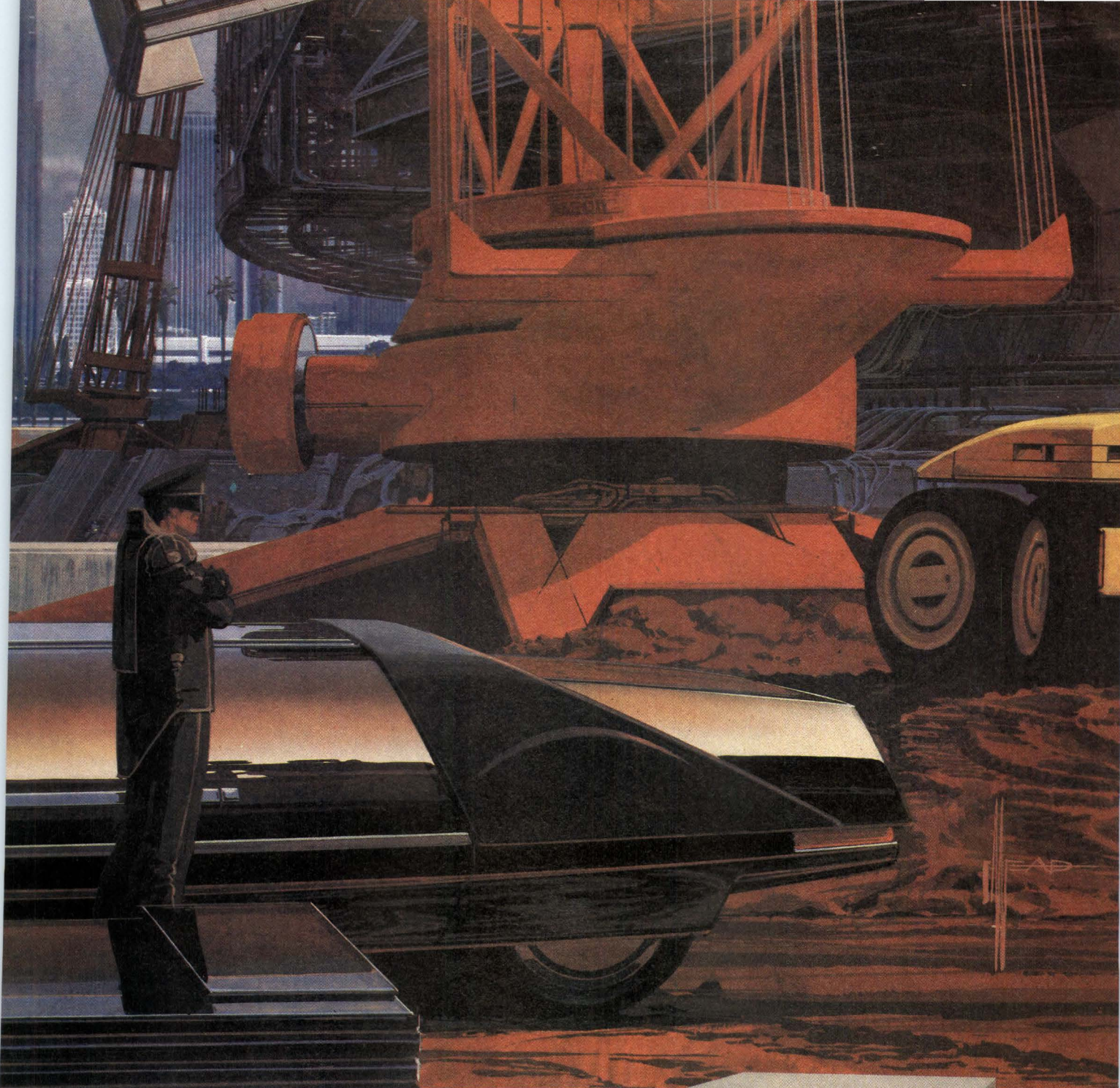

AVAILABLE TODAY.

Computer graphic systems will soon be as common as typewriters in the business and industrial world. Conrac, the leading name in video monitors for over 37 years, will be a part of those systems. Conrac has sales offices and service centers located in principal cities across the country — with more on the way.

Find out more about the advanced concept new Conrac 7300. Use the Reader Service number or call Marketing Communications at (213) 966-3511.

Contact Conrac Division for a full color reproduction of this illustration which is suitable for framing.

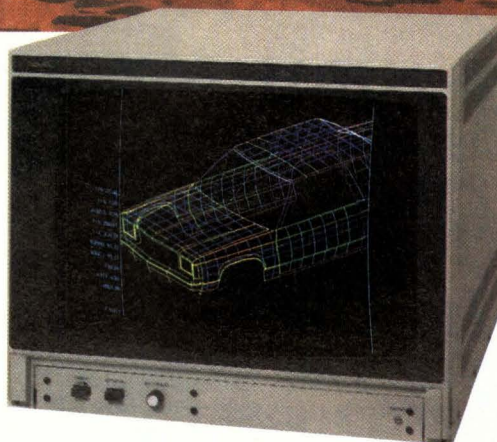

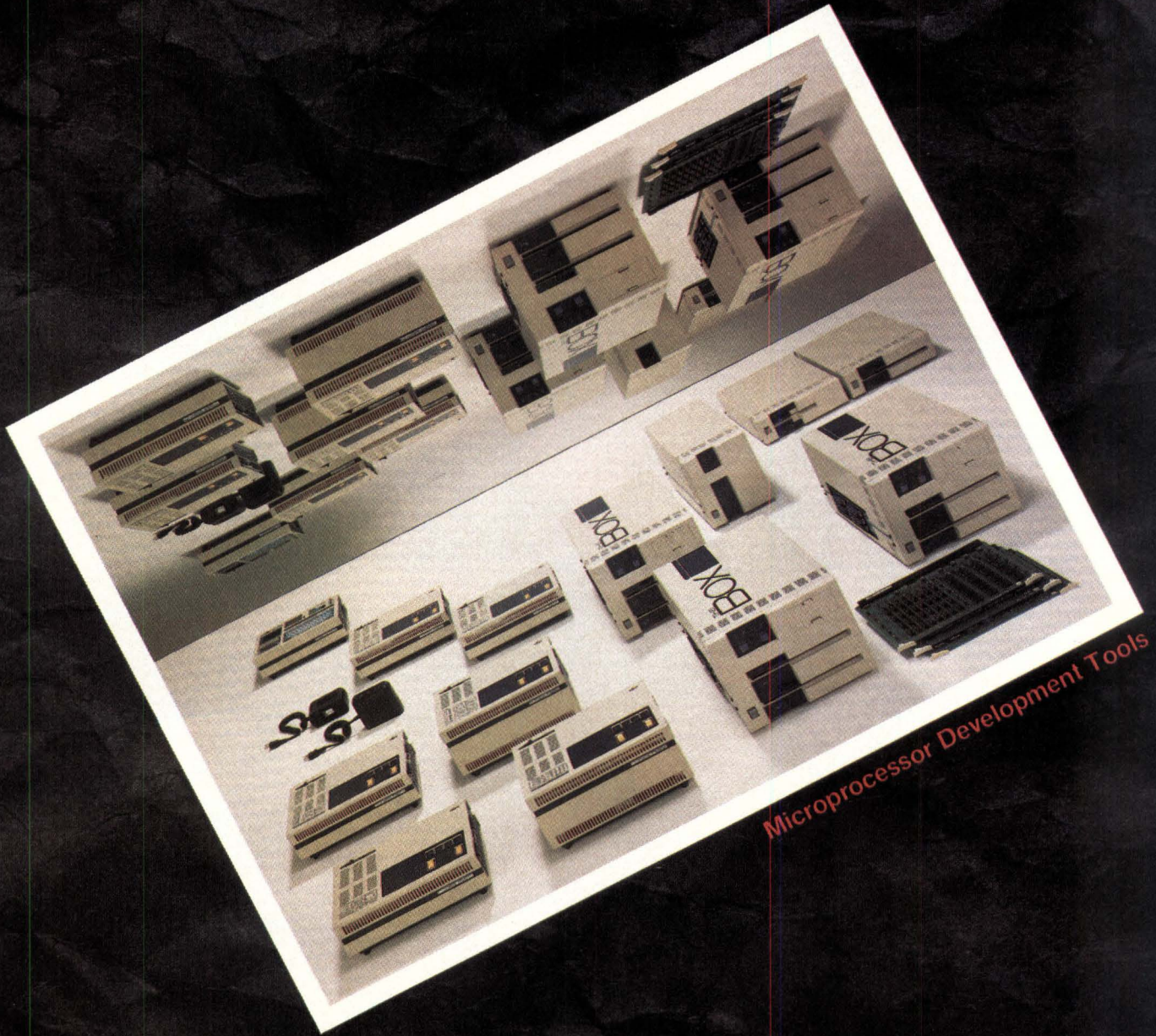

Microprocessor Development Tools

Z...ing

ZPerformance	ZCommitment	ZResponsibility
ZAssurance	ZPrice	ZSolidty
ZCharacter	ZGenuis	ZStyle
ZPossibilities	ZDependability	ZPersonalty
ZImagination	ZCreativeness	ZInventiveness
ZOrganization	ZDesign	ZStructure
ZUnity	ZApplication	ZCooperation
ZExpertise	ZAbility	ZIntelligence
ZCapability	ZDirection	ZQuality
ZLoyalty	ZDevotion	ZTechnology
ZTalent	ZInvolvement	ZProficiency
ZArtistry	ZWorkmanship	ZExcellence
ZSupremacy	ZPerception	ZDurability
ZPower	ZKnowledge	ZSkill
ZSupport	ZAccuracy	ZStrength
ZSpirit	ZDistinction	ZReliability
ZEfficiency	ZVersatility	ZAnswer

ZAX

Zax Corporation 2572 White Road, Irvine, California 92714
(714) 474-1170 • 800-421-0982 • TLX 183829

CIRCLE 93

AMCC

metamorphosis

dramatically transforms your designs
into high performance

ECL/TTL logic arrays.

Like metamorphosis in nature, we're dramatically transforming logic and board designs into semicustom, ECL/TTL logic arrays that stretch the imagination ... that advance the state of the art in military systems, communications, test, instrumentation, computer systems and peripherals.

If you need sub-nanosecond performance ... ECL speeds at LSTTL power ... ECL, TTL, or mixed I/O ... up front design flexibility with engineer-to-engineer support ... full CAD capability and the highest functionality macro library available ... Mil. Spec. 883C ... a source with fully integrated wafer fabrication, assembly and test ... up to 95% utilization with auto place/route ... six to eight week prototype turnaround ... and fast reliable delivery of production quantities ... Call us. Let us prove that we can dramatically convert your designs into high performance logic arrays ... it's what we call AMCC metamorphosis.

Ask about our newest product ... our Q1500 Series with 120 I/Os, 1700 gates, ECL, TTL or mixed I/O, and high functionality macros ... and get data sheets on the other members of our logic array family.

AMCC ECL/TTL GATE ARRAYS

	QH1500A	Q1500A	Q700	Q710	Q720
Equivalent Gates	1700	1500	1000	500	250
Typ. Gate Delay (nS)	.9	.9	.9	.9	.9
Typ. Power (W)	2.8	2.5	2.0	1.2	.6
I/Os	120	84	76	56	36
Gate Utilization	95%	95%	85%	85%	85%

Get all the facts:

Call or write for information on our line of logic arrays and our capabilities. Write: Applied Micro Circuits Corporation, 5502 Oberlin Drive, San Diego, California 92121. Telephone: (619) 450-9333. TWX/Telex: 910-337-1136.

AMCC

APPLIED MICRO CIRCUITS CORPORATION

Nature's metamorphosis ...

dramatically transforms a caterpillar using its eight pairs of legs to crawl along a leaf ... into an incredible, winged butterfly.

CIRCLE 94

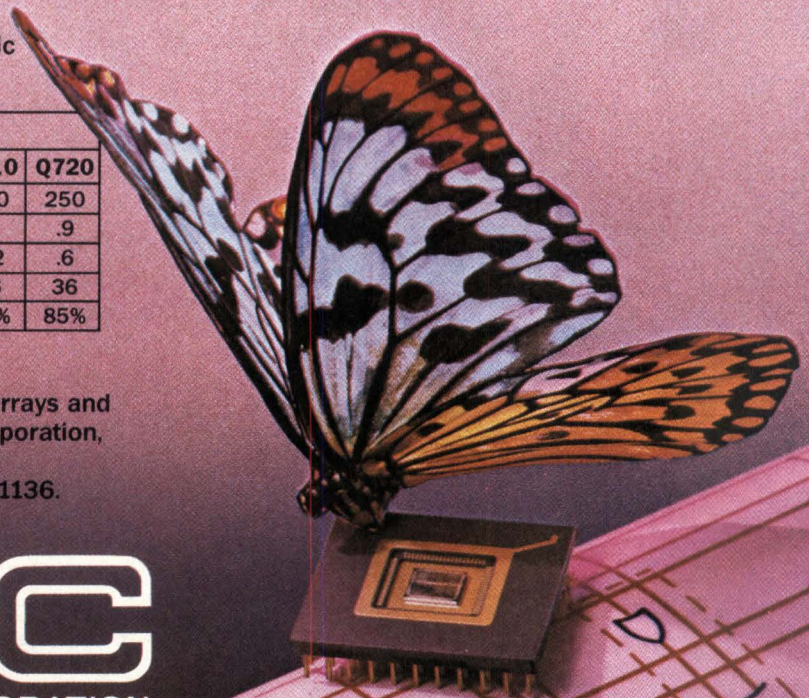



MICROPROGRAMMING VERSUS MICROPROCESSORS

Designers who choose a standard microprocessor chip may quickly discover that semicustom and custom variations have boxed them out of the market, and that microprogramming is indeed the wave of the future.

**by Bjorn Dahlberg and
Wendy Kane Wanderman**

Despite tremendous growth in the use of standard microprocessor chips, these off-the-shelf devices are inadequate in many design situations. Using them can often hinder a clean, top-down design approach, and stifle designer creativity. In some cases, too many support chips are required to achieve the desired control and performance. This raises system cost dramatically. In other cases, the software needed to make these chips perform as desired becomes enormously complex, raising real costs excessively. This software, which accounts for

Bjorn Dahlberg is president of Hilevel Technology, Inc, Irvine Technology Center, 18902 Bardeen Way, Irvine, CA 92715. He holds an MSEE from the University of Pittsburgh and a BSEE from Michigan Technological University.

Wendy Kane Wanderman is an associate professor of electrical/computer engineering at California State Polytechnic University in Pomona, where she is coordinator of the computer aided engineering laboratory. She holds an MSEE from New York University and a BSEE from New York City University.

60 percent or more of the total effort, is relatively unprotected; that is, it is easily copied. This leaves the designer at the mercy of competitors. Furthermore, since commonly available chips are used extensively, the capabilities and limitations of the selected chips tend to define, and can limit, overall system performance.

Microprogramming is reemerging as an alternative to this dilemma. Microprogrammed bit-slice processors, custom VLSI, and other nonstandard forms offer designers the chance to achieve superior system performance, and to implement more functions in less time. Microprogrammed designs can also be more secure while offering more flexible upgrade paths. These advantages can help designers meet critical market windows and extend product life cycles. A microprogrammed design by itself offers better proprietary protection than a design based on off-the-shelf microprocessors. In addition, this protection is further magnified when the design is embedded in a custom or semicustom VLSI chip.

The concept of microprogramming originated in the 1950s and although overshadowed later by random-logic design, it has made steady inroads. With increased interest over the last decade (that parallels the industry's accelerated interest in semicustom and custom chips) a new wave of use is underway. This activity is still limited by

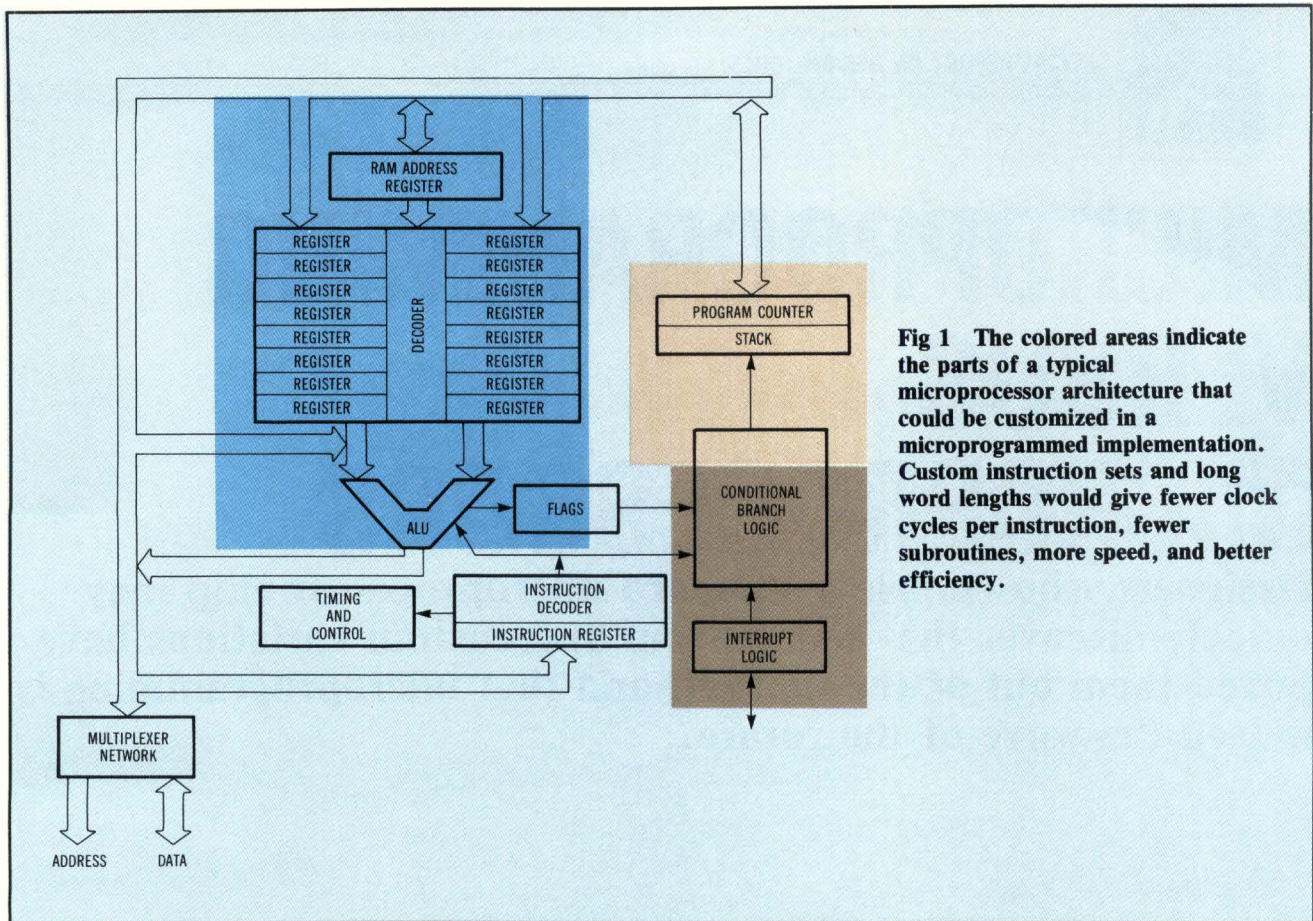

Fig 1 The colored areas indicate the parts of a typical microprocessor architecture that could be customized in a microprogrammed implementation. Custom instruction sets and long word lengths would give fewer clock cycles per instruction, fewer subroutines, more speed, and better efficiency.

misunderstandings that have obscured the validity of the microprogrammed approach. Some designers still believe that microprogramming is outdated, uneconomical, overly complex, or poorly supported by development tools and instruments. Many automatically turn to the off-the-shelf solution—chips that have essentially become minicomputers on silicon, with fixed architectures and instruction sets. These Von Neumann-based architectures are familiar and easy to use. Even when in ROM, the program and data reside in the same logical memory. Since these devices are so well (and permanently) defined, support software, hardware tools, application notes, and supply sources are readily available. The temptation to use them is great, requiring little or no justification to associates or management. But, it also suppresses designer creativity and can mean loss of the competitive edge, which in turn affects the bottom line.

On the other hand, microprogrammable elements actually place fewer constraints on the designer (Fig 1). The designer is free to create the instruction set that makes overall operation most efficient. The architecture (data path width) can be matched to the application (number crunching capability). When compared to a microprocessor software solution, this is not much more complex, and support tools are now readily available to make the task easier than ever. A design team with a good mixture of hardware and software expertise—working closely

together from concept to project completion—can greatly reduce the problems that normally occur in integrating hardware and software. For these reasons, an examination of some popularly held beliefs (and misconceptions) about microprogramming is in order.

Microprocessors are not always cheaper

Microprocessors are poorly structured for high speed I/O. I/O operations generally take several instructions. Each instruction takes several clock cycles, and fetching data and instructions consumes memory bandwidth. I/O also frequently calls for time-critical handshaking, something microprocessors are ill suited to handle. The microprocessor itself may be capable of handling only the simplest I/O (ie, terminals and printers). To overcome these limitations, designers often turn to special I/O processors with their own memory, to DMA, and to special interrupt handling hardware and software. Such solutions are costly, and require more logic, power, memory, and software. They are also more complex, both in hardware and software (which is likely to be excessive), making the solution inefficient as well.

Microprogrammed designs generally have enough bandwidth to allow I/O processing on demand. The I/O handler can be microcoded, for the most part, resulting in faster interrupt and I/O processing. Code and data reside in separate, high speed

If you've been waiting for a supermicro with UNIX* System V on a 68010-based processor, stop.

Introducing the Callan Unistar™ 300. It's the single best supermicro you can buy. For a couple of reasons:

One, the 10MHz 68010 CPU. It's the newest, fastest, best. It crunches numbers in a snap. And works beautifully with the new UNIX.

Two, the new UNIX System V. It's faster than UNIX System III. On the Unistar 300, it supports a host of languages. And when it comes to portability, flexibility and system support, nothing comes close.

There's more. The Unistar 300 allows for expansion to 172M bytes of high-speed disk storage with integral tape backup—all within one enclosure that easily fits under a desk.

Its convenient 12-slot Multibus* chassis lets you easily add options like networking, communications, floating point array processors and more. Up to 2M bytes of main memory provide real power for every user. And nationwide service is available through ITT/Courier.

Unistar 300. Finally a supermicro with super everything. Available today from Callan. For more information contact Callan Data Systems, 2645 Townsgate Road, Westlake Village, CA 91361. (800) 235-7055. In California (805) 497-6837. TELEX 910 336 1685.

Callan Unistar

*Callan and Unistar are trademarks of Callan Data Systems. UNIX is a trademark of Bell Labs. Multibus is a trademark of Intel Corporation.



SUPER. MICRO.

A short history of microprogramming

The word microprogram was first coined by M.V. Wilkes, in his paper, "The Best Way to Design a Calculating Machine." At the same time, a battle for prominence among computer thinkers was being waged between two distinguished schools: Harvard and Princeton. The winner was Princeton with the Princeton or Von Neumann machine. The Harvard machine, however, had an architecture that possessed all the elements of a microprogrammed structure. There was no clear association between the Harvard design and Wilkes's idea, but ironically, what he was suggesting would eventually allow the Princeton machine to be driven by a Harvard machine.

Microprogramming gained considerable prominence when IBM used the technique in some mid-size and small models of the 360 series mainframes, such as the 360/55. The memories used were capacitive Mylar memories, too slow for the largest mainframes. With introduction of bipolar ROMs in the 1960s and field programmable ROMs/PROMs in the early 1970s, the microprogramming technique was embraced by many of the emerging minicomputer manufacturers. Microdata Corp (Irvine, Calif) was one such pioneer. Microdata's *Microprogramming Handbook* (Microdata Corp, Santa Ana, Calif, 1971) contained what is thought to be the first reference to firmware—a term that originally meant microprogram, not microprocessor program stored in ROM or PROM.

Microprogramming became exceedingly popular in the 1970s. Random logic designs were replaced by structured and well-organized microprogram designs. During that time, some designers contended that microprogramming was slower than random logic. To some extent that was true. Microprogramming, however, offered the opportunity to incorporate higher level instruction such as string search and floating point multiply as basic machine instructions at little cost. These operations were

often executed by software routines. The speed advantage of incorporating these operations in the basic instruction set was immense.

Smart controllers were a direct result of incorporating microprogramming into the I/O. Many CPU functions were offloaded by this approach, and a host of diagnostic features were added. Then, the true viable microprocessor (ie, small processor) emerged. The 8080 was crude, but it succeeded beyond almost everyone's expectations. It was random logic, but in silicon. The 8080 represented a gigantic step to those needing an affordable processor, but in a sense, it also represented a step backward in the advancement of computer science. The emergence of higher level machine instructions was abruptly halted by a crudeness which belonged in the previous decade. Its success is history, however, and the 8080 no doubt expanded computer usage.

Since the 8080, many more powerful microprocessors have emerged—the micro applies to the processor's physical size rather than to its processing power. With that, an interesting phenomenon occurred. The microprocessors became microprogrammed. The microprogram, however, resides inside the chip. And is the conceptual difference inside a chip or a PC board? Perhaps, the most significant difference is how to test and debug the board or the chip.

Custom chip design is a booming business today. Whole companies are dedicated to transforming existing boards into a single chip or implementing a new design in silicon. The emergence of custom chips as a commonplace alternative is evident. As complexity on the silicon increases, it seems only natural that most of these designs would be microprogrammed. Microprogramming offers designers the freedom to choose the optimum architecture for their applications while maintaining an orderly design structure.

memories and are fetched simultaneously. Programmable pulses and levels (pulse and level orders) can be matched to the I/O requirements, and can be handled without resorting to complicated microprocessor software. Interrupt driven, burst I/O is handled especially well by the microprogrammed or bit-slice approach.

As an example, a simple routine to send data to a universal asynchronous receiver/transmitter (UART) takes 6.6 μ s (exclusive of wait loops) when coded for a 10-MHz 8086. A microprogrammed implementation for a bit-slice architecture would typically take 600 ns, given an equivalent clock rate. The speed-up (almost a full order of magnitude) has obvious advantages in time-critical applications.

Special interfaces pose similar problems because the designer usually must develop a random logic interface, matching the I/O to the chip's architecture, and much of this is done in software. The hardware interface requires more devices and more power, conflicting with modular microprocessor-based design goals and advantages. Software

routines must be written in assembly language, complicating software development. The software often requires excessive overhead, which is usually solved by adding yet another microprocessor to drive the interface. This, of course, requires additional software and defeats the primary design goal of keeping things simple. Again, microprogramming is an excellent alternative. The flexibility of the microprogrammed or bit-slice solution generally leads to a smaller, simpler, and cheaper design when special interfaces are involved.

Beware of special processing, too. Microprocessor implementations usually involve development of assembly language function routines, the design of special hardware, or the introduction of coprocessors. All of these can introduce latency and slow the system down, by requiring additional registers, scratchpad RAM, etc. Microprogramming, of course, can avoid these problems.

Microprocessor designs are not always easier to implement. This is especially true if multiple processors are used to solve a problem that could be

solved by a single bit-slice processor. It is also true when the chip's instruction set does not match the task (eg, doing a fast Fourier transform with an 8086) or when special random logic must be developed. When using a microprocessor, the designer must rely on sophisticated in-circuit emulators and software tools. The tools may not be readily available, may never become available, may be limited in capability, may not operate in a general environment, and may not run in real time.

Eliminating random logic

The microprogrammed approach is actually simpler, because the components employed are more general and more pliable. Register file structures and pulse/level order design can be closely tied to the microcode, eliminating random logic and simplifying the design. The microcode can be tailored to the architecture. New firmware development tools now give the designer all the capability (PROM emulation and sophisticated logic analysis) needed to develop the hardware and software.

Microprocessor implementations are not necessarily more advanced. LSI, state-of-the-art components are available in both microprogrammable and off-the-shelf forms. Furthermore, many popular chips were, in fact, developed with microprogramming techniques. But these standard devices are often not well suited to handle I/O processing or string processing, multiprocessing and heavy arithmetic applications. State-of-the-art chips with more sophisticated instructions and special architectures, such as stack implementations, do offer more capability, but still do not match the capability of a custom bit-slice implementation on a PC board, or in a custom VLSI device. The ability to map hardware to architecture through microcode is a great advantage, and the code resides in the densest of components, the PROM.

Off-the-shelf solutions often grow quite complex when elements are added that require truly random logic.

Microprogramming eliminates random logic. While it is true that part counts for such designs may be higher than a simple microprocessor-based design, random logic requirements may be no more extensive. Off-the-shelf solutions often grow quite complex when elements are added that require truly random logic to hold the system components, processors, and interfaces together. But even when the microprogrammed approach requires more components, these often function as blocks instead of as random gates. The microprogrammed approach more readily supports a top-down design methodology, yielding a cleaner solution.

Microprocessors are often selected for the more complex applications. Using a completely self-contained intelligent chip is alluring. But, now that effective development tools exist for microprogrammed devices, they should also be considered for complex applications. With the right tools, designers can microprogram a new and better generation of processors.

Microprogramming use has grown slowly but steadily since its inception. In the 1960s, for example, most computer systems were built with hardwired random logic, but by the 1970s mainframes and minicomputers were taking advantage of microprogramming's flexibility. Many of today's most popular microprocessor chips were developed with microprogramming and some, such as the TI7000, are microprogrammable to match user requirements. The industry's current hot topic is the integration of complete systems onto single silicon chips. The process of putting PC boards into silicon is taking microprogramming out of the backroom.

Microprogramming: an old idea but not outdated

Microprogramming no longer means "computer monks," quill pens, and volumes of hand-assembled code. Today's microprogramming recruits are third-generation chip users who have witnessed several performance revolutions. They have worked with the early (primitive) chips and support tools, as well as with sophisticated development systems and computer aided engineering workstations. They have come to expect more capability in their software and hardware development tools, and if it is not available off-the-shelf, they will build their own solutions. Many already have.

This new generation of microprogrammers also has expertise that crosses two disciplines: hardware and software development. While this hybrid designer has traditionally been a rare breed, the number of engineers thoroughly familiar with both disciplines is increasing. This trend will also accelerate, as will applications for VLSI, gate-arrays, and standard cells.

Microprogramming uncomplicates things because, contrary to popular belief, it is fundamentally simple, and with the right tools, it is far easier to use than assembly language (Fig 2). If good microcode assemblers had been available 8 or 10 years ago, microprogramming would have been far more popular. Early assemblers that accompanied development systems supporting the first bit-slice products were indeed primitive. Today's macro assembler is highly structured and allows the programmer to define macros to speed up program development. Custom assemblers that allow arithmetic syntax in a way similar to that of a Fortran compiler, (with constructs that resemble those found in Pascal) can be (and have been) developed rather easily to accommodate specific tasks. It

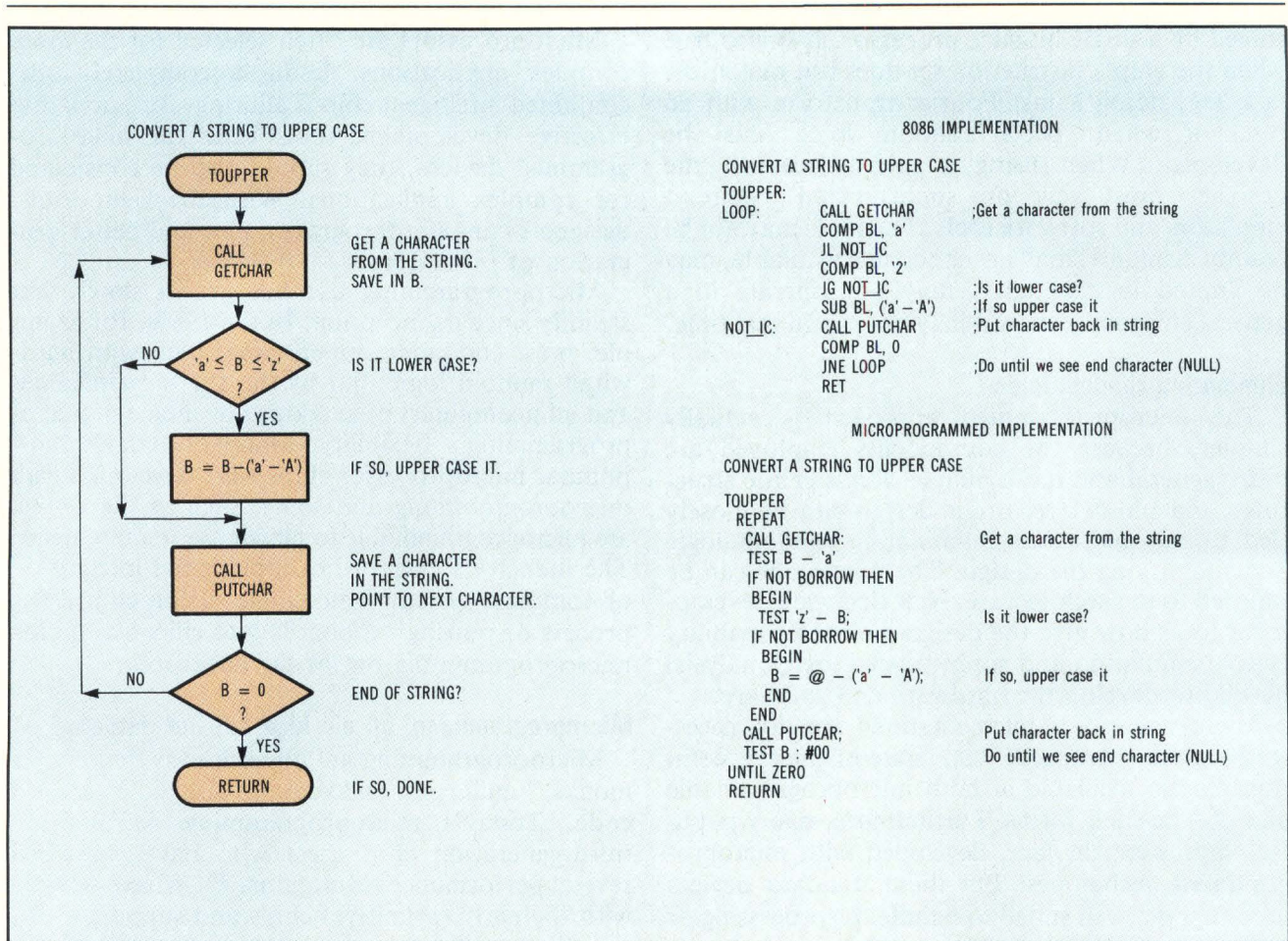

Fig 2 Pictured is the program implementation with 8086 versus microcode. Compilers and assemblers available today take the complexity out of microprogramming. The high level like language and ability to structure the program will make it easier to follow and debug in the future.

takes skill and creativity to design a microprogrammed structure that is powerful and yet easy to use. On the other hand, it is easy to fall into the trap of designing a structure that executes fast but takes forever to program.

Today's firmware tools pave the way

The current crop of firmware development tools is amazingly productive and advanced. PROM emulation (writable control store) and third-generation logic analysis capabilities are combined. The incorporated features rival or exceed those available in development systems designed to support standard microprocessors. For example, a performance analysis capability is available that allows the designer to detect potential design problems, software traffic jams, and architectural inefficiencies early in the development cycle. With this feature the designer can make hardware and software trade-off decisions, and avoid costly redesign.

Multilevel triggering, up to 16 levels with 8 qualifiers each, is available in some systems, along with selective trace and selective snapshot facilities. These features allow the user to define complex patterns and events, and allow the capture of data

that simple development systems might never see. Unwanted data must be filtered out, so that only meaningful information is captured for review. User-defined instruction mnemonics and alphanumeric labels are provided, to identify traced events at a glance. Parameter cross-checking minimizes errors. Histograms display buffer utilization and simplify trigger program refinements. Comprehensive display prompting, help files, and other user-accommodating features are available.

More advanced firmware development tools are on the drawing board and new entrants expected in this field will give the user an even broader range of selection in choosing support tools.

Please rate the value of this article to you by circling the appropriate number in the "Editorial Score Box" on the Inquiry Card.

High 716

Average 717

Low 718

This New Fiber Optic Modem will Extend a DCE Interface to Any Point in Your Local Area Network.

Plus a whole lot more.

- Can also be used for standard modem applications
- Automatically accepts or supplies DCE/DTE clocks
- Fully supports all EIA handshaking signals
- Provides secondary data channel

In short, you can use our new fiber optic modem between any two plug compatible units in your local area network. And it won't require any jury-rigging or looping clock and interface signals. That's because, from an operating standpoint, our fiber optic modem looks just like an EIA cable; whether you're going from a long-haul

modem to a remote terminal or from a CPU port to a printer. And it's just about as easy to install as a cable — we even provide two separate connectors (DTE and DCE) on each modem. YOU determine how our modem will function simply by selecting which connector you use!

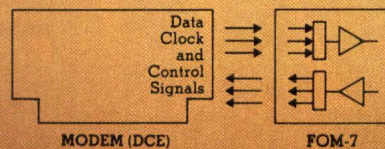

Once our fiber optic modem is installed and operating it'll really begin to shine. You'll benefit not only

from the advantages inherent with fiber optics (traffic security plus noise immunity) but also from the exceptional operating performance. Our very low error

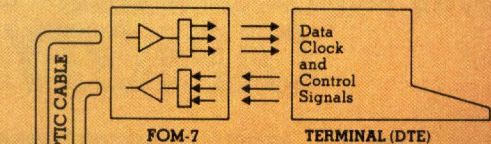

rate and continual signal quality monitoring means that you'll operate with a higher throughput and less downtime than ever before.

Versitron manufactures a complete line of fiber optic products for Local Area Networks. Our 20 years' experience in fiber optic is reflected in the performance capabilities of our products.

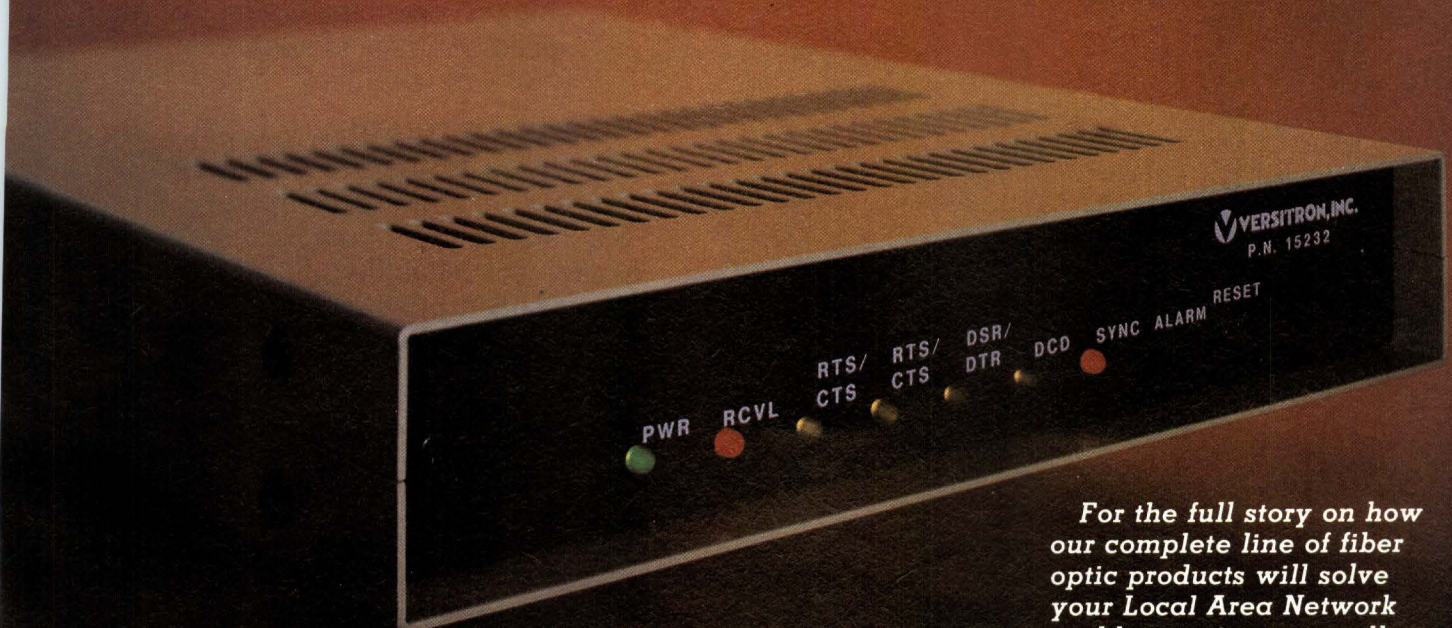

For the full story on how our complete line of fiber optic products will solve your Local Area Network problems, give us a call at (202) 882-8464. Or write:

VERSITRON, INC.

6310 Chillum Place, N.W., Washington, D.C. 20011, TWX: 710-822-1179

CIRCLE 96

DRIVE YOUR SYSTEM TO NEW HEIGHTS.

UNPARALLELED 8-INCH WINCHESTER DRIVE CAPACITY AND PERFORMANCE.

167.7 MB

The drive is on. Your customers expect more and more from computer systems today. And one of the best ways to stay ahead is to specify 8-inch Winchester drives from NEC Information Systems.

Take the D2257, for example. It provides 167.7 megabytes of storage with access time of 20 milliseconds. It's the highest capacity available at any speed. And it's available right now - in volume.

Proven reliability from the people who make Spinwriter.

Throughout the computer industry, NEC's Spinwriter means superior quality and reliability.

So it's not surprising our 8-inch Winchester drives perform at two to three times the industry's MTBF. And our average repair time is just 30 minutes.

That means lower service costs and increased customer satisfaction.

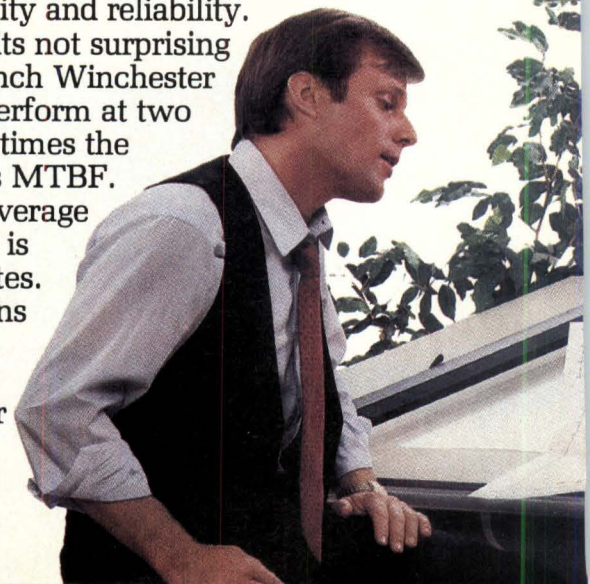

We use a conventional SMD interface.

So our drives are easy to use.

It's simple to integrate NEC's 8-inch Winchester drives into your system. The reason is our standard Storage Module Device (SMD) type interface.

In addition, you wind up with significant savings in installation, packaging, maintenance and cost-of-ownership.

NEC. Technology drives us.

NEC has been pioneering advancements in electronics for



Choose from four high performance capacities: 25.7, 42.5, 85.0 and 167.7 MB.

almost 85 years. We've been developing disk drives since 1959.

Our 8-inch Winchester drive technology is state-of-the-art, while other NEC drives

A standard SMD interface, standard forms factor and low dc power requirements mean easy system integration.

IMMEDIATE DELIVERY

An evaluation unit will be shipped within 72 hours from the time your PO is received.

incorporate such advanced technology as plated media, thin-film heads and optical recording.

Clearly, NEC remains at the leading edge.

For more information on NEC 8-inch and 5 $\frac{1}{4}$ -inch Winchester and flexible drives, or the name of your nearest NEC representative, call 1-800-343-4418 (In Massachusetts, call 617-264-8635). You'll find out why more and more OEM's are saying "NEC and me."

**NEC
AND
ME**

NEC Information Systems, Inc.
1414 Massachusetts Avenue
Boxborough, MA 01719

CIRCLE 97

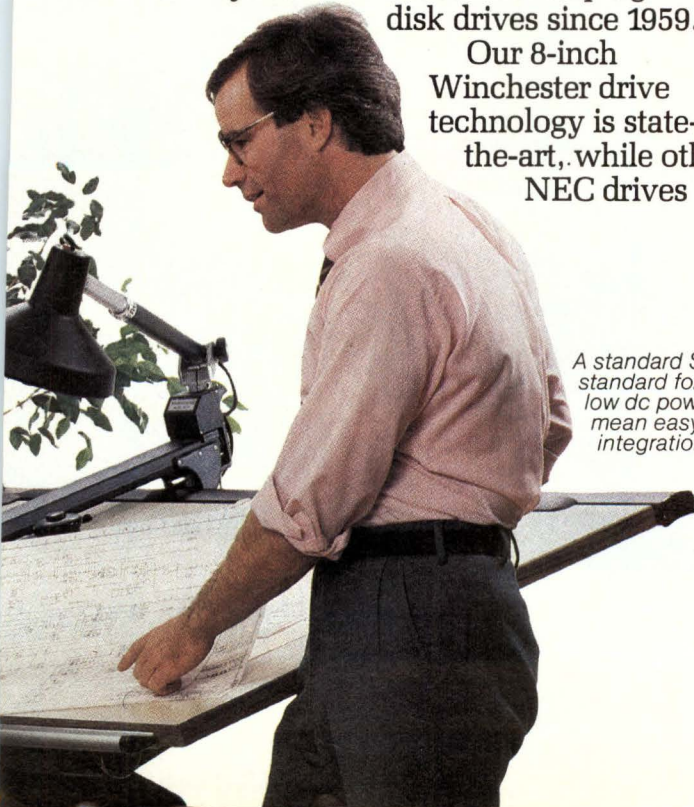
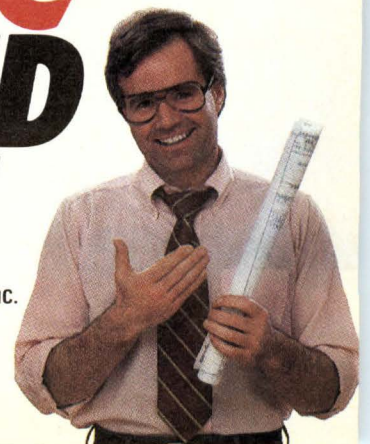

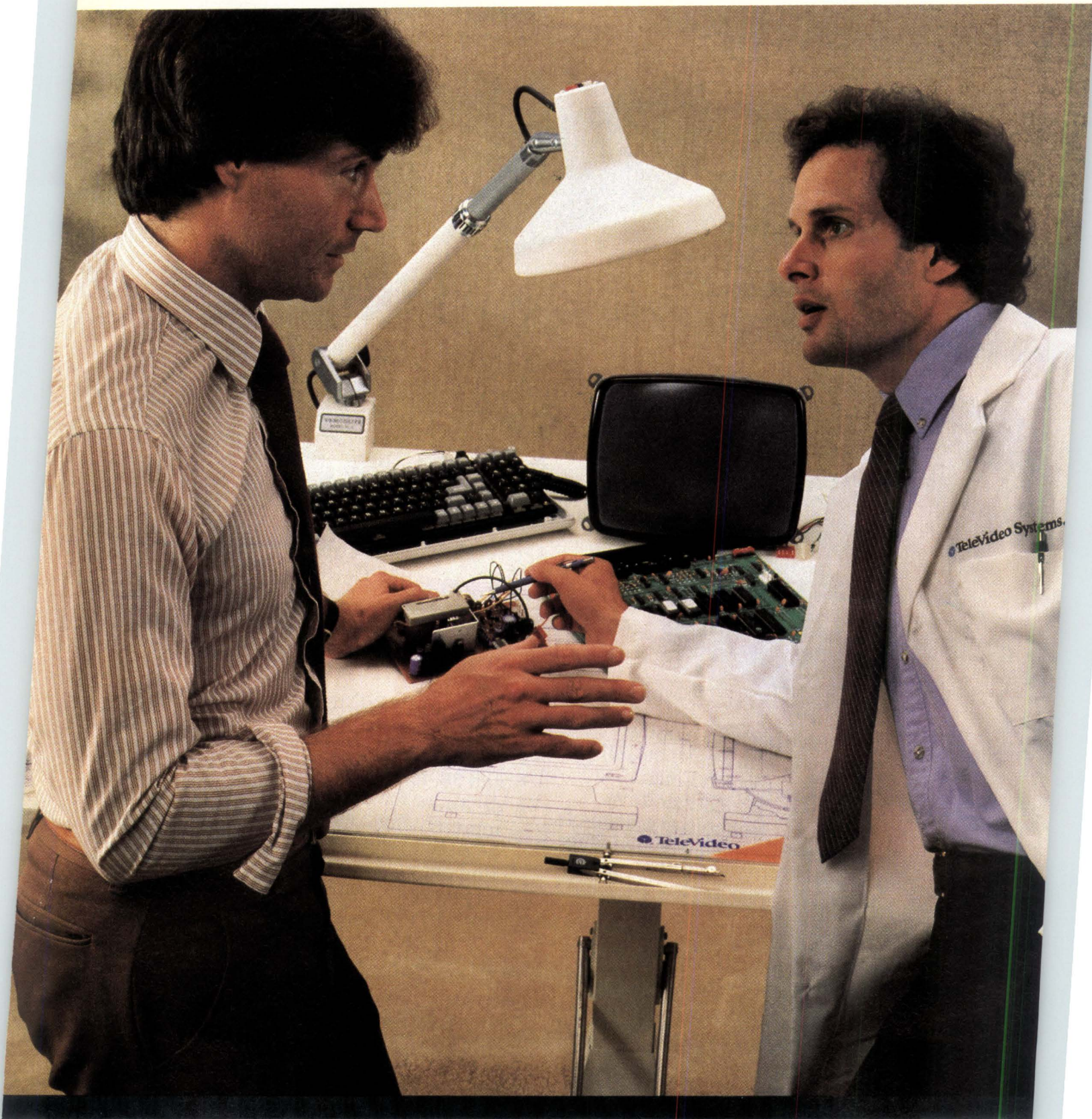

TELEVIDEO'S OEM BOOM. FULL PARTNERSHIPS AVAILABLE.

To get where you want to go in the OEM universe, you need a partner. One who can go the distance with you. A vendor who puts design innovation, reliability and flexibility first. We're TeleVideo® and we do just that. That's why we're the independent industry leader in terminals.

TeleVideo assigns you one applications engineer throughout design, manufacture and delivery. Our goal is not just to meet your specs but also your business requirements. We'll manufacture your terminals in the new state-of-the-art facility we've built for OEM custom assembly. We'll test the units your way. With your QC standards.

We keep the contract simple, back you up with continued technical support, and live up to the TeleVideo reputation for quick delivery and reliability. That minimizes your risks.

Our partnerships with present OEMs are long term successes. That's because TeleVideo combines innovative modular design and serviceability with pioneering work in ergonomics and protocol standards.

Experience the confidence of a partnership with TeleVideo for yourself. Contact us today, whatever your terminal requirements. It's time we explored your corner of the OEM universe together.

Call us at (800) 538-8725 for more information (in California call (408) 745-7760) or contact your nearest TeleVideo office.

California/Santa Ana	(714) 476-0244	New York/New York	(516) 496-4777
California/Sunnyvale	(408) 745-7760	Texas/Dallas	(214) 258-6776
Georgia/Atlanta	(404) 399-6464	Central Europe (The Netherlands)	(31) 2503-35444
Illinois/Chicago	(312) 397-5400	Northern Europe (United Kingdom)	(44) 9-905-6464
Massachusetts/Boston	(617) 890-3282	Southern Europe (France)	(33) 1-686-4412

GET IN ON
THE BOOM.™



TeleVideo® Terminals

TeleVideo Systems, Inc.

DEVELOP NON-INTEL MICROPROCESSORS WITH YOUR INTELLEC® or iPDS®

If you own or are considering buying an Intellec or iPDS Microcomputer Development System, then you need RELMS' powerful relocatable macro cross-assemblers and in-circuit emulators for complete support.

With these tools and your Intellec or iPDS, you can develop products based on non-Intel microprocessors while minimizing your capital equipment outlays.

Compatibility is the key to engineering productivity.

RELMS assemblers and emulators are completely compatible with all Intel development systems—both the Intellec and the iPDS—as well as all manufacturers' syntax (Zilog, Mostek, Fairchild, Rockwell and Motorola), and produce an ISIS-II compatible output.

Capitalize on your experience curve.

The RELMS cross-assemblers utilize directives similar to those used in the Intel 8085 assembler, reducing the need to learn new commands.

The RELMS assembler modules can be combined with Intel PLM-80 and other compiler output modules to produce optimal programs. Then your Spice® in-circuit emulator can be used to debug and integrate the program with your product hardware.

Complete support. Today and tomorrow.

RELMS is committed to supporting 8 and 16-bit microprocessors not supported by Intel with total support packages that include complete

documentation, free updates, three-month maintenance on Spice units and a full year of maintenance on RELMS software.*

Versatility, efficiency and speed.

RELMS in-circuit emulators now feature:

- Full symbolic debug
- Dynamic symbolic trace
- Batch disassembly
- Interrupt trace all modes
- Realtime emulation
- Relational breaks and Breakregion™
- Realtime trace memory
- Relocation registers
- Memory disassembler

Order now.

RELMS cross-assemblers and Spice in-circuit emulators are available, today, off-the-shelf, for immediate delivery. For further information, clip the coupon or write: RELMS, 1650-B Berryessa Road San Jose, CA 95131 Telephone (408) 729-3011 TWX 910-374-0014

	Z80/Z80A/8800/6801/6802/6803/6808	6805	6809A/E	F8/3870/3872/3874/3876	6500/6501/6502	1802	Z8000	Z80 (CMOS)	68000	NSC800	9900/9995	80C85 (CMOS)
EMULATORS	●						●	●				●
ASSEMBLERS	●	●	●	●	●	●	●	●	●	●	●	●

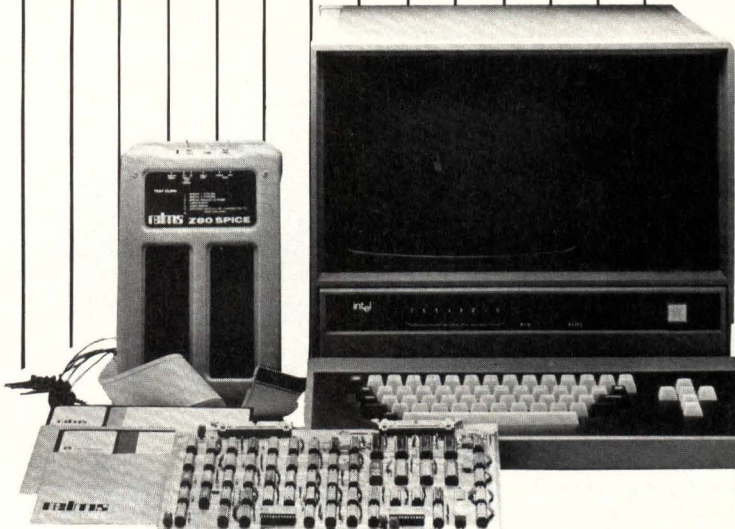

RELMS ASSEMBLERS

Z80

6800

6805

6809

F8

6500

1802

Z8000

Z8

68000

NSC800

9900

8051

8085

IN-CIRCUIT EMULATORS

Z80A

Z80B

NSC800

8085

Z80 (CMOS)

80C85

RELMS . . .

Please rush me more information on your assemblers.

Your incredibly powerful in-circuit emulators, Spice, sound fantastic, too. Send me complete data.

I'm interested in other high performance development tools for my application, which is: _____

My Intellec model # is: _____

I plan to develop the following microprocessors: _____

Name _____ Title _____

Company _____

Address _____

City _____ State _____ Zip _____

Phone (____) _____

*Extended maintenance contracts available. Intellec and iPDS are registered trademarks of Intel Corporation. Spice and Breakregion are registered trademarks of Relational Memory Systems, Inc. Z80 is a registered trademark of Zilog Corporation. NSC800 is a registered trademark of National Semiconductor Corporation.

relms®
Relational Memory Systems, Inc.



EXPANDED DESIGN CYCLES DEMAND NEW DEVELOPMENT TOOLS

Make sure that microprocessor development tools support rather than dictate the design.

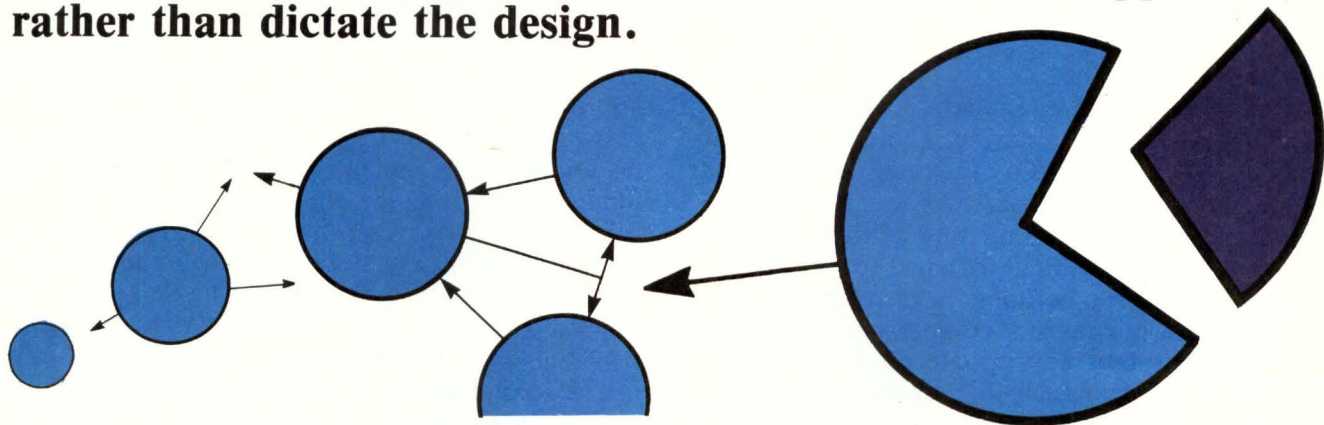

by John R. Adam

Almost no design of a microprocessor-based product takes place today without the support of a development system or the equivalent capability. Two major trends must be considered when evaluating microprocessor development methods. First, the growing number of competing systems and instruments that can be used in the design process is becoming overwhelming. Second, the use of gate arrays, standard cells and custom LSI, and the ever-increasing amount of software that needs to be developed has placed new demands on the development environment.

Beginning in the early 1970s with the Intel MDS-800, development systems have provided the software and hardware development tools to support

John R. Adam is marketing manager of Kontron Electronics, 5730 Buckingham Pkwy, Culver City, CA 90230, where he is responsible for digital instrumentation. Dr Adam holds a BS, an MS, and a PhD in electrical engineering from the University of Illinois.

microprocessor-based design. As development requirements have changed, so have development systems. For example, multi-user systems have kept pace with the growth in the size of development teams and powerful, universal in-circuit emulation and logic analysis have matched the requirements of the fastest 8- and 16-bit chips. High level languages have been developed to support the growing software development task.

In the last three years, the development environment has radically changed. These changes include the size and organization of the development team, significant new development procedures, and documentation and control requirements. Data bases have mushroomed, and new security methods have been installed. Traditional development systems consisting of basic desktop microcomputers and software tools with emulation and logic analysis attached, only address a subset of today's development environments. For example, the design team with responsibility for hundreds of thousands lines of code which must be written, debugged, and mated to hardware has significantly different needs from a single designer who is writing a videogame or small application program. To address the needs of the full user community,

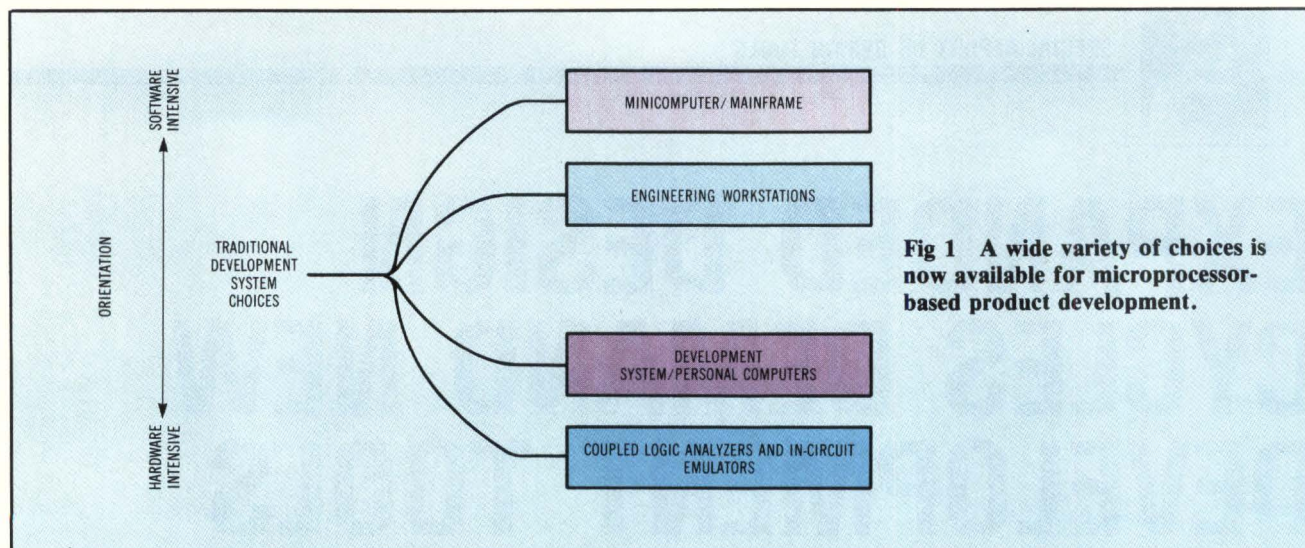

Fig 1 A wide variety of choices is now available for microprocessor-based product development.

development system manufacturers have therefore had to broaden their product offerings.

Development choices

The range of development choices is shown in Fig 1. The alternatives are categorized by the size of the total effort and by the relative size of software and hardware tasks. Although all product development is really a mixture of these tasks, the time spent or individuals assigned to each effort is a key parameter in defining the development environment. For purposes of comparison, the assumption is made that appropriate development tools exist in all environments. These include languages for software development, in-circuit emulation, logic analysis, and PROM programming for hardware debugging and software/hardware integration. Furthermore, these tools must exist for the particular microprocessor being used. This is the case today for most popular 8- and 16-bit microprocessors. However, all of the required support tools may not be available from one vendor. This can create a compatibility problem that must be closely examined before a development system choice is made.

In large software-intensive projects with several simultaneous users, the development system must provide each user access to a large data base that can be partitioned by subtask. The data base must support the security and backup procedures the team adopts or the organization dictates. Since multiple program compile and assembly operations must be executed simultaneously, a large computing resource is needed. In this environment, a high performance minicomputer is the appropriate choice. While the initial investment is high, the cost per user is typically less than for a collection of individual development systems.

The demand for tools in this environment has been filled, to a large extent. This is especially true for DEC PDP-11 and VAX users. Several software

suppliers, including Language Resources and Boston Systems Office, offer cross compilers and assemblers for microprocessor software development in the DEC environment. For the first approach (hardware development and hardware/software integration), two choices exist: interface a traditional development system to the minicomputer (most development system manufacturers offer utility packages for this purpose), or eliminate the development system and mate the in-circuit emulator directly to the mini. This lets any user access an emulator directly from a VT102 terminal. Kontron and Tektronix offer such systems.

The second approach is development of an engineering workstation. Workstations provide gate array, standard cell, custom LSI, and PC board computer aided design (CAD); microprocessor-oriented software and hardware features; word processing; and when networked, electronic mail project control, and documentation capability. Still in its infancy, the workstation approach is intended to provide a full turnkey solution to the development effort. The adoption of standard operating systems, such as Bell Labs' Unix, and networking schemes will relieve the user from matching incompatible systems and tools.

The third approach is a collection of individual, traditional development systems. Such a configuration is directed toward projects with an equal mix of software and hardware tasks. Since development systems have integrated software and hardware development tools, individual users can switch between them readily. This environment is appropriate for a group of contributors or for a project that can be partitioned into clearly defined subtasks. While most development systems support some form of networking scheme, they do not provide the software management functions associated with minicomputers or workstations.

An offshoot of this third approach is to substitute an inexpensive personal computer for the

FOR MULTIBUS AND EXORCISER COMPATIBLE BOARDS...

NOBODY MATCHES BURR-BROWN!

When you need I/O boards, there is one place to call. Burr-Brown.

SELECTION

Over 35 boards compatible with Intel Multibus alone . . . 30 with Motorola EXORciser, DEC LSI-11, and Zilog.

QUALITY

Each board is made with the technical precision and reliability that has become our trademark worldwide, because every board is burned in at 70° centigrade for 120 hours.

PRICE

You can have the exceptional performance and selection of Burr-Brown at a price that's competitive with anyone . . . and a full-year warranty to back it up.

MICROCOMPUTER INPUT/OUTPUT BOARDS

INTEL AND NATIONAL MULTIBUS COMPATIBLE

Intel iSBC80 and 86, ICS80 and MDS800, National BLC80 and Starplex, and other Multibus Systems.

MODEL NUMBER	DESCRIPTION
ANALOG INPUT	
MP8418-PGA	15-channel Differential/31-channel single-ended, Fixed gain, 12-bit.
MP8418-PGA	15-channel Differential/31-channel single-ended, Programmable Gain, 12-bit.
ANALOG INPUT/OUTPUT	
MP8418-AO	15-channel Differential/31-channel single-ended input, Fixed Gain, 12-bit. 2-channel output, ±10VDC, 12-bit (individual DACs)
MP8418-PGA-AO	15-channel Differential/31-channel single-ended input. Programmable Gain, 12-bit. 2-channel output, ±10VDC
ANALOG OUTPUT	
MP8316-I	16-channel 0-20mA, 12-bit (common DAC).
MP8316-V	16-channel ±10VDC, 12-bit (common DAC).
SPECIAL PURPOSE INPUT	
MP8430	16-channel RTD 3-wire (100 ohm or 1000 ohm).
DISCRETE OPTICALLY ISOLATED INPUT	
MP810	24-channel Dry-Contact Closure, 1.5mA Wetting Current at 24VDC.
DISCRETE REED RELAY OUTPUT	
MP802	32-channel Relay, 0.5A at 28VDC
DISCRETE INPUT/OUTPUT	
MP830-72	72-channel TTL levels. User configured in 8-channel increments of inputs or outputs.
MOTOROLA EXORCISER COMPATIBLE	
Motorola Exorciser, Rockwell System 65 and Synertek Systems.	
ANALOG INPUT	
MP7217	16-channel, single-ended, Fixed Gain, 12-bit.
ANALOG INPUT/OUTPUT	
MP7432-AO	32-channel Differential/64-channel single-ended inputs, Fixed Gain, 8-bit. 2-channel output, ±10VDC, 8-bit (individual DACs).
DISCRETE OPTICALLY ISOLATED INPUT	
MP710	24-channel Dry Contact Closures, 1.5mA Wetting Current at 24VDC.
DISCRETE REED RELAY OUTPUT	
MP702	32-channel relay, 0.5A at 28VDC.
DEC LSI-11 COMPATIBLE	
LSI-11, -11/2, -11/23 PDP 11/03, 11/23	
ANALOG INPUT	
MP1216-PGA	16-channel Differential/32-channel single-ended, Programmable Gain, 12-bit.
ZILOG Z80 COMPATIBLE Z90, MCS	
ANALOG INPUT/OUTPUT	
MP2216-AO	16-channel Differential/32-channel single-ended inputs, Fixed Gain, 12-bit. 2-channel ±10VDC outputs, 12-bit (individual DACs)

BURR-BROWN®

Call us...



Tomorrow's Solutions Today.

* PARTIAL LISTING. FOR COMPLETE
HARDCOPY OF BURR-BROWN
COMPATIBLE CARDS, CONTACT:

Data Acquisition and Control Systems Division
3631 E. 44th St., Tucson, Az. 85713 (602) 747-0711 TWX: 910-952-1115

CIRCLE 100

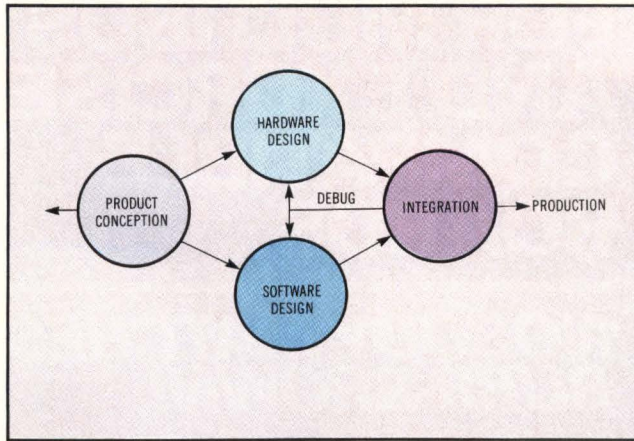

Fig 2 Pictured is a traditional microprocessor-oriented design cycle with separate hardware and software functions.

microcomputer used in traditional development systems. This approach is attractive because of the low cost, adequate performance, and availability of personal computers; and the wide range of non-development software available, such as word processing packages that support the development effort. Complete sets of professional quality microprocessor-oriented development tools for personal computers have yet to emerge. Some tools are available, such as software development tools from RTCS Corp, logic analysis packages from Northwest Instruments, and semicustom design software from FutureNet.

The fourth choice, coupled instrumentation, is most useful in hardware-intensive environments with limited software development requirements such as hardware development labs, prototype or limited production operations, or repair centers. This approach is based on closely coupled logic analysis and in-circuit emulation. The in-circuit

emulator is used to control data capture by the logic analyzer. The results of the data capture are then used to control program execution. The Dolch Atlas and Kontron Laser systems are examples of this type of system.

Changing design cycles

The design process of the last 10 years can be represented by the cycle shown in Fig 2. In the product conception phase, features and capabilities are determined and enumerated in a specification. The features are then partitioned into hardware and software tasks. Individual tasks in each area are defined and completed independently. When the tasks are completed, they are integrated to produce the final result. If problems are discovered, the software and hardware are modified and the integration continued until a functional prototype is obtained.

As the typical design has become more complex, the development cycle has expanded to that shown in Fig 3. In the concept phase, along with the functional ability of the product, a detailed analysis of the available software and hardware development approaches can be made.

It is assumed that a standard microprocessor is at the heart of these designs. In the foreseeable future, microprocessors will be the major controlling element in the design cycle. This will hold true due to the mass of software currently available and the ease of writing new software. Indeed, the trend is toward multiple microprocessors with tasks partitioned among them.

Developers must answer hard questions. Can the software be partitioned into a kernel that handles all of the hardware-dependent functions? Should this

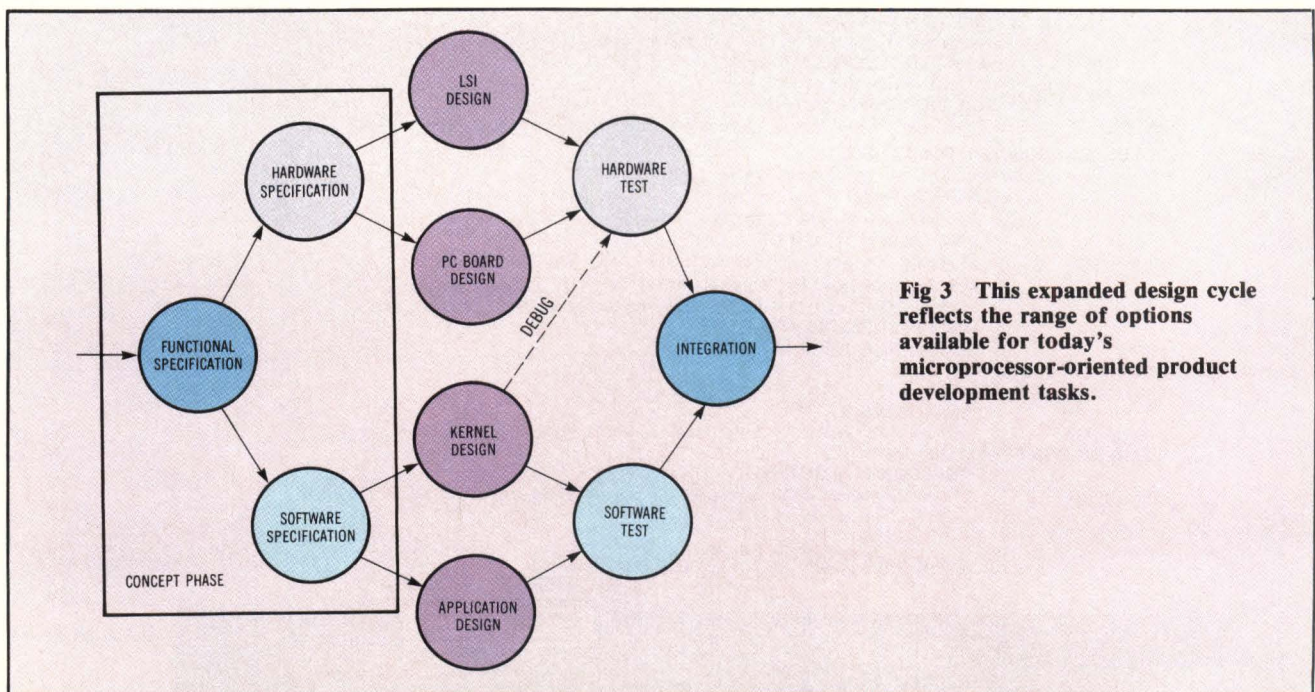

Fig 3 This expanded design cycle reflects the range of options available for today's microprocessor-oriented product development tasks.

GTCO DIGITIZERS MAKE YOU NUMBER ONE

We're the largest producer of electromagnetic digitizers. So we can deliver field proven tablets in the quantity you need... when you need them.

Our Digi-Pad family uses new technology to provide unique digitizer features.

- **PRESSURE PEN**
The pressure sensing pen option gives the operator a more natural input... perfect for the artist.
- **4D**
The 4D option provides another independent variable proportional to stylus tilt and direction... like a joy stick.
- **SELF DIAGNOSTICS**
A 4-tone alarm reports test results for all components including the tablet grid... insuring digitizer integrity.

Every Digi-Pad is compatible. So when you develop your software and interface around our smallest and least expensive Digi-Pad (under \$1000), you can interchange any other size Digi-Pad without redesign. Digi-Pad is also compliant with U.L., FCC and many other standards.

Give your system an edge. Choose the number one digitizer from GTCO.
Call us at (301) 279-9550 today.



GTCO Corporation

1055 First St. / Rockville, MD 20850
(301) 279-9550 Telex 898471

CIRCLE 101

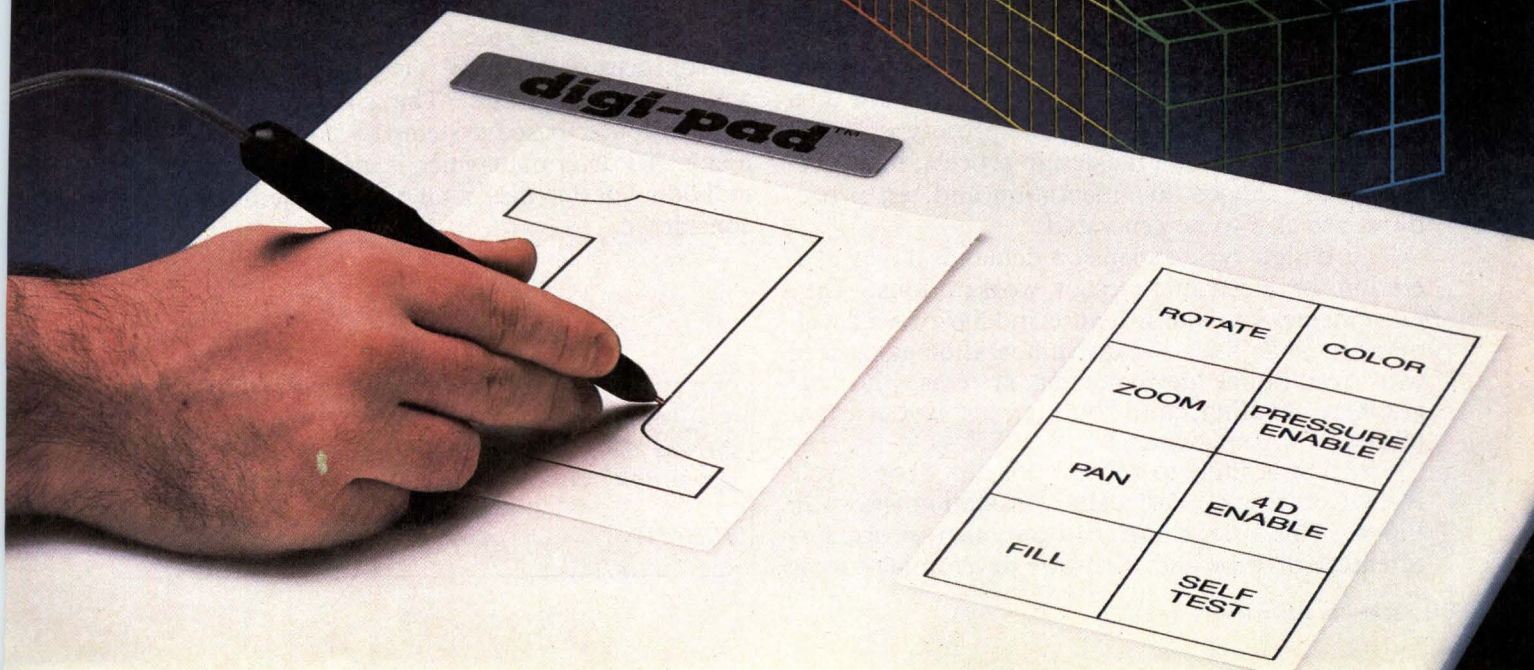



Fig 4 Kontron's team workstation combines microprocessor software and hardware development with PC board layout and gate array design.

be a standard operating system kernel? Can the application software, which controls the product's functional ability, be separated? If it can, this relieves the design engineer from the task of knowing the hardware implementation details, since calls to the kernel handle this task. Separation also allows the application to be written in a high level language. The application can be debugged independent of the hardware and easily modified to produce multiple versions customized to specific uses or markets.

At the hardware concept level, similar issues exist. For speed, product protection, or other reasons, there is a question as to whether or not custom components should be used. There are a wide range of choices including gate arrays, standard cells, and semi- or custom-LSI. The PC board must be designed and laid out. The combination of the custom LSI, the PC board, and the operating software kernel must be tested. The combination of the completed software and hardware are then integrated to produce a complete prototype. As an auxiliary output from the design process, manufacturing and service documentation and test procedures are also to be generated.

This design cycle expansion demands a new generation of electronic design workstations. They must incorporate the software and hardware development capabilities and instrumentation associated with traditional development systems plus the graphics handling, auto-routing, and layout capabilities of CAD systems.

The first product to address this new design cycle is the Kontron KDS 980 team workstation shown in Fig 4. This system offers both microprocessor-oriented software and hardware development tools

and CAD features in one distributed processing, multi-user configuration. This arrangement, in addition to supporting the major design cycle elements, provides a large shared data base and features such as electronic mail.

Simulation is the one major element missing in this design cycle. Rudimentary simulation of a gate array or PC board can be performed today. The goal however, is to be able to simulate a complete product. This includes not only the hardware portion but the hardware-dependent software kernel. This type of simulation will, if not eliminate, at least drastically reduce troubleshooting during the prototype phase. Such simulation capability should be available on development workstations in the near future.

The design environment, type and size of tasks, changing technology, and organizational characteristics all play a role in determining the type of microprocessor-oriented development tools that are most appropriate. The choices range from minicomputer-based systems to standalone instruments. To determine which is most appropriate for individual design needs, all of these factors must be considered.

Please rate the value of this article to you by circling the appropriate number in the "Editorial Score Box" on the Inquiry Card.

High 719

Average 720

Low 721



A wider range of streamers you cannot get...

not with IBM format compatibility and over 40% common components.

Now, for the first time, there's a family of high quality 1/2 inch streaming tape drives to match almost every need and budget. We simply ask you to compare them with ordinary streamers and then make your choice from the world's smallest 1/2" machine our 9800, the high capacity low profile 9900, or the high performance 8900.

No worries about the future either. Plan now to meet your immediate needs, extend later to higher densities and capacities.

Compare these innovations, many unique, and all common to the THORN EMI streamer family. Then compare the price:-

- IBM/ANSI/ECMA 9-track formats
- Multi-mode, multi speed operation
- Autoloading on 9900 and 9800
- Maximum unformatted capacities, based on thin based tapes; 34.5 M bytes (9800) 138 M bytes (9900, 8900)
- 25, 50 and 100 ips streaming.
- 50 ips genuine start/stop-(8900)
- 1600 bpi and double density 3200 bpi PE
- 800 bpi NRZ (8900)
- 3-level diagnostics, operator and remotely controlled
- Unambiguous scrolled alphanumeric display
- 8 registers for status and error logging
- Common operator control sequences
- UL, CSA, VDE, FCC, BS & IEC Safety and RFI standards
- Spare pcb slot for cache memory, serial, parallel or user special interface
- Plug-in optimum sized pcb's
- Industry standard interfaces
- Integral power unit



THORN EMI Technology Inc.

Computer Products, 8601 Dunwoody Place, Atlanta GA 30338
Tel: (404) 587-0017 Telex: 810-7662267.

REST OF WORLD: THORN EMI DATATECH LTD. Spur Road, Feltham, Middlesex, TW14 0TD, England. Tel: 01-890-1477 Telex: 23995.

CIRCLE 102

WHOEVER FINIS

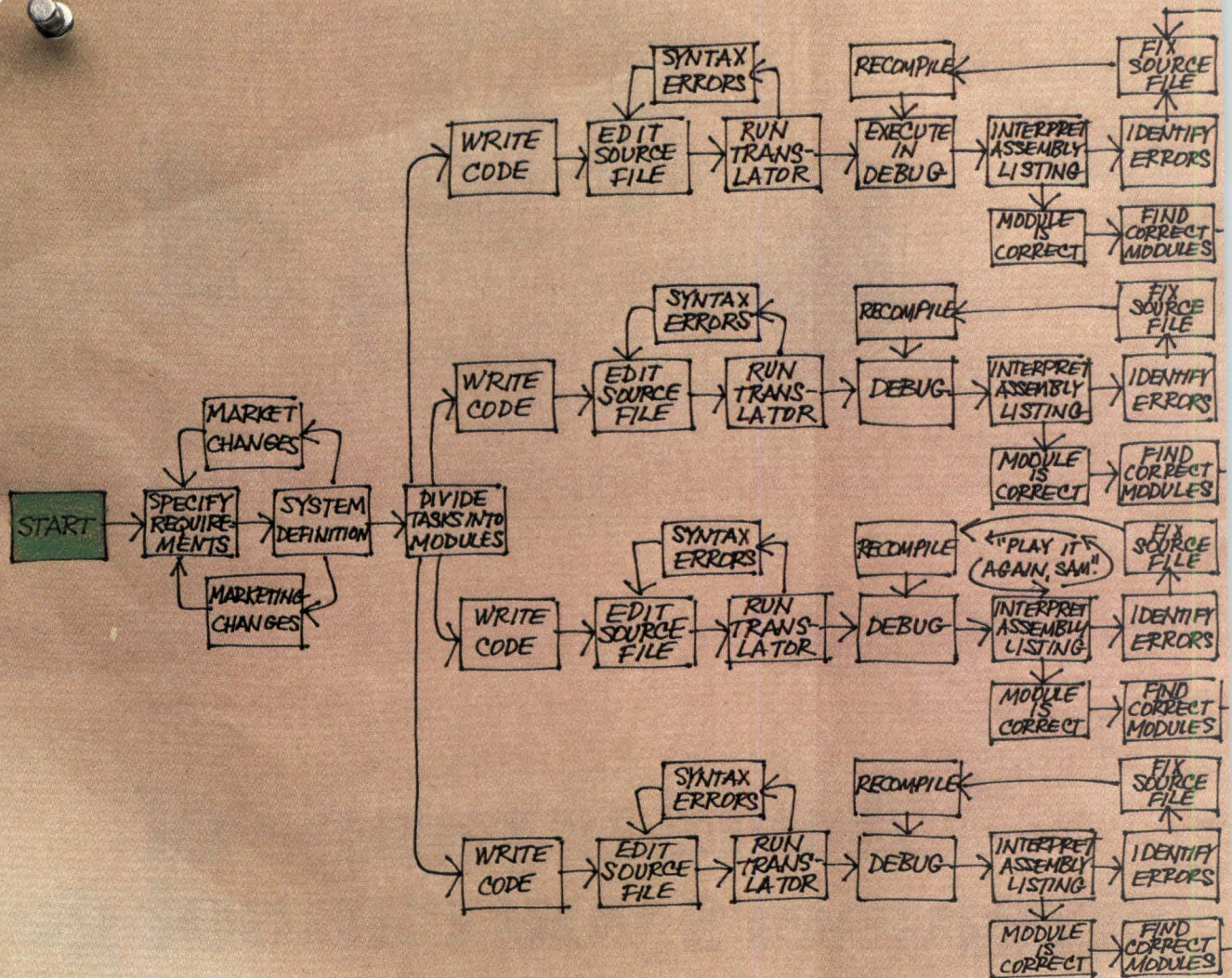

It's a wonder anything ever gets finished. Fortunately, it doesn't have to be that way. Even though you're developing a complex system, the system development can be simple. And timely.

With development tools from Intel. The most complete, fully-integrated set of hardware and software development tools in the industry.

You can work in a variety of high level languages—PL/M, Pascal, FORTRAN or C—from the very beginning. And our tools will keep you at that high level where you're most productive.

Take our PSCOPE debugger. It lets you

detect and patch all program errors at the source level in your choice of PL/M, Pascal, or FORTRAN. Then you recompile just once.

Same for our LINK utility.

It allows someone to work in Pascal and someone else to work in PL/M, and then makes short work of the integration.

Very slick. But you're also going to love SVCS and MAKE.

SVCS stands for Software Version Control System and it functions as a data base manager that automatically logs who makes changes, when, and why.

Then our MAKE utility automatically finds the correct versions of each module, automati-

HES FIRST WINS.

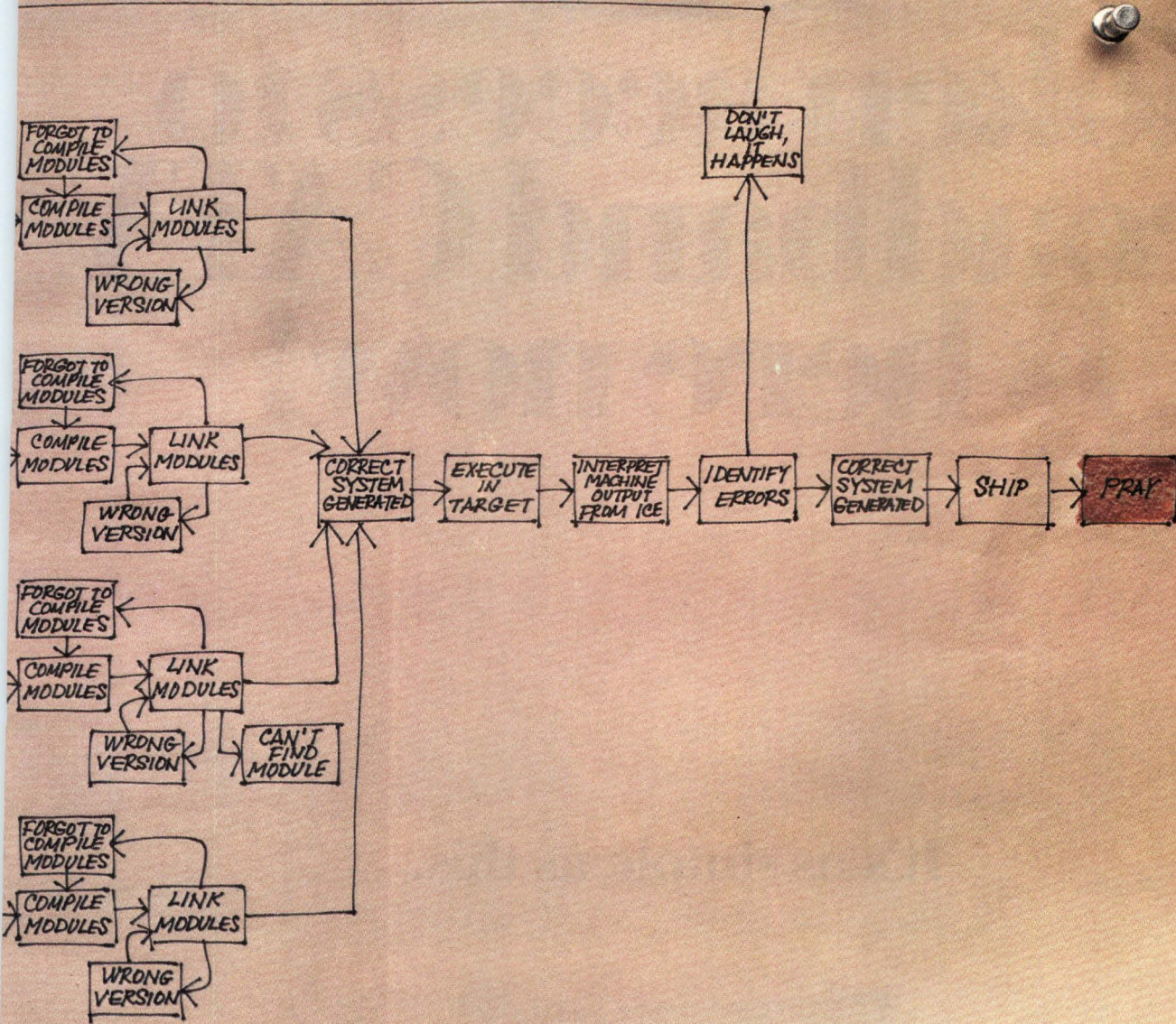

cally recompiles those modules that need it, and produces the complete, correct system. Automatically, of course.

Which brings us to I²ICE™, our Integrated Instrumentation and In-Circuit Emulation System. I²ICE uses the same high level human interface as PSCOPE, so you don't have to learn a new one. It also emulates at full speed, real time, to eliminate any tricky little timing problems. And of course, it supports every processor in the iAPX86 family.

We also have a variety of Intellec® Development Systems for them to plug into.

Not to mention the best in project management and control, our Network Development

System, NDS II, allows you to share resources and communicate throughout the process.

What's more, these tools are available at the same time as the silicon they were made for.

Engineering assistance and training workshops are available as well. As is a lot more information.

Just call (800) 538-1876. In California, (800) 672-1833. Or write Intel, Lit. Dept. I-8, 3065 Bowers Ave., Santa Clara, CA 95050.

But do it soon. Whoever finishes first wins. Everybody else just finishes.

intel® delivers solutions

© 1983 Intel Corporation

LAN: Token access to broadband CATV is here now!

It's as simple as this.



Inside each Token/Net™ Interface Module (TIM) is everything you need to build a turn-key, 5Mbps, unlimited distance, collision free, local area network—fully compatible with IEEE 802 and ECMA standards *and* with support of any synchronous or asynchronous equipment. If you're really serious about solving large capacity, real-time networking needs, call us at (617) 890-1394. There's no better solution than Token/Net. Concord Data Systems, 303 Bear Hill Road, Waltham, MA 02154, Telex: 95-1793. Regional Offices: Illinois, (312) 251-8336, California, (714) 541-4974.



CONCORD DATA SYSTEMS
LINKING COMMUNICATIONS TECHNOLOGIES

See us at **COMMUNICATION NETWORKS CONFERENCE & EXPOSITION**
Washington, D.C. January 31—February 2, 1984

CIRCLE 104



SIMPLIFY PROGRAMMING OF REALTIME SYSTEMS

Designers need development tools to test and interactively refine realtime applications. A tool for testing a routine in a high level language and then compiling it into a compact ROMable form is very valuable.

by **Evan Solley**

Realtime programs have a unique set of requirements and constraints that set them apart from other software engineering tasks. Producing error-free code is difficult for two reasons: the need to deal explicitly with time constraints, and the need to deal with hardware at a very primitive level. Moreover, most standard programming languages offer little help in these areas. Realtime facilities are usually extensions to a language provided by either a specific vendor or the application engineer.

A tool for building realtime programs should be a complete programming environment designed specifically for microprocessor-based realtime applications. It must combine features usually distributed among high and low level language translators, realtime operating systems, and support tools such as editors, linkers, and debuggers. It must also produce fast-executing compiled code when testing is complete. In addition, when the software is developed and tested on the target system, there can be no discrepancies, as with cross-development techniques, between the development and the target environments.

Evan L. Solley is president of Infosphere, Inc, 4730 SW Macadam Ave, Portland, OR 97201. He has studied design and organization science at Roger Williams College, and has participated in the system science program at Portland State University.

Timing dependencies, imposed by external hardware or physical processes, present a major challenge in realtime programs. The need for raw speed is one example. A realtime program gets input from a device or process, and generates a controlling response. The program must be fast enough to perform calculations and make decisions in time to guarantee stability, which may be only a few milliseconds.

To ensure the necessary response, Infosphere's programming tool, Sphere, is a threaded-code language similar to Forth. Complex functions are built up from the predefined primitives provided in the Sphere nucleus. Primitives are coded in assembly language, while composite (user-defined) operators are compiled as address lists that point directly to the component primitives. The result is a compact code that executes at compiler speeds, while providing a mechanism for interactivity. The system can also operate in an interpretive mode in which new definitions are added to a dictionary and incrementally compiled. Once defined, the target system can immediately execute the new operators to run at full compiled speed.

In addition to Forth's speed, the programming system provides the clarity of Pascal with the classic block control structures: IF-THEN-ELSE, REPEAT-UNTIL, CASE, and DO-LOOPS. Table 1 is an example of how to define and use operators. The system uses postfix (reverse polish) notation, to simplify the language syntax and minimize the complexity of token parsing. Arguments are passed on a dedicated parameter stack, making all

TABLE 1
Sphere Code Example

	Pseudocode comments:
> % Sphere code:	
> HEX	% set hexadecimal radix
> 1 'ENABLE CONST	% define constants
> 0 'DISABLE CONST	
> 0FFFF 'POS CONST	
> 0 'NEG CONST	
>	%
>	%
> 'START :	% start motor:
1> ENABLE DRIVE !	% drive := enable
1> 10 1 DO	% for i= 1 to 10 do
2> 1 30 * OUTPUT !	% output := 30*i
2> 2 SLEEP	% delay 2 system ticks
2> LOOP ;	% end
>	%
>	%
> 'STOP :	% stop motor:
1> 10 1 DO	% for i= 1 to 10 do
2> 10 i - 30 * OUTPUT !	% output := (10-i)*30
2> 2 SLEEP	% delay 2 system ticks
2> LOOP	% end
1> DISABLE DRIVE ! ;	% drive := disable
>	%
>	%
> 'SET SPEED :	% set speed:
1> MOTION @	% get MOTION value
1> CASE	% case MOTION of
2> -1 { STOP }	% -1: stop
2> 0 { }	% 0: do nothing
2> 1 { START }	% 1: start
2> END ;	% end
>	%
>	%
> 'SET DIRECTION :	% set motor direction:
1> MOTOR @ GTZ	% test MOTOR
1> IFT	% if 0
2> DIRECTION POS !	% direction := pos
2> ELSE	% else
2> DIRECTION NEG !	% direction := neg
2> ENDIF ;	% end
>	%
>	%
> 'MOTOR_CONTROL :	% main operator:
1> REPEAT	% repeat
2> SET_DIRECTION	% set direction
2> SET_SPEED	% set speed
2> FOREVER ;	% forever
>	%

operators reentrant. This is important in a multitasking environment, where several concurrent tasks may use a given operator.

In Table 1, several operators are defined using primitives. The system indicates the nesting level within definitions and block structures to the left of the prompt character (>). First, the START operator enables a motor drive, then outputs a set of 10 values—one every two system clock ticks—to control motor speed. The effect is to ramp the motor up to speed.

The STOP operator does just the reverse. Based on the value of a variable called MOTION, the SET_SPEED operator determines whether to call START or STOP (or do nothing). The SET_DIRECTION operator tests a variable called MOTOR to determine what to write to the motor direction control register. Finally, MOTOR_CONTROL, the main operator and an infinite loop, calls the other operators to control motor direction and speed.

Two other aspects of timing dependencies are closely related: responding to asynchronous external events and multitasking. Realtime problems require a program to respond quickly to external events, which are essentially random with respect to the program sequence. Event-driven programs take their action cues from the external system.

A program can sense external events through polling, but most systems use hardware interrupts to alert the program about an event, and to pass control directly to an associated routine. Facilities deal with interrupts directly in high level language, and the context is saved and restored automatically. The programmer does not need assembly code interrupt service routines or special software interfaces to incorporate interrupts into the application. This saves time, and enhances program portability, since no processor-specific code is required.

Multitasking facilities

The problem of maintaining the logical flow of program segments that deal with various external events becomes manageable if it can be broken into independent tasks that focus on various components of the problem. These tasks execute concurrently on the target processor, corresponding to the multiple physical (or electrical) processes that the program must deal with. However, multiple tasks require a special routine, called a multitasking executive, to handle execution of the tasks. This allows tasks to communicate in a coordinated manner, and gives them access to the processor and other resources.

Traditionally, the programmer had two ways to provide multitasking in an application: to incorporate a large multitasking operating system into the target; or to write a special purpose multitasking executive. An integral multitasking executive is part of the sphere runtime nucleus that allows the programmer to create and run as many tasks as needed. Since the entire runtime system fits into 16 Kbytes (two 64-K or one 128-K ROM), the memory required to support multitasking is minimal.

The scheduler manages processor resources according to a preemptive scheduling algorithm that has been assigned a priority. When an interrupt or a signal from another task occurs, the scheduler searches a list of ready tasks and starts the one with the highest priority. It will even replace the previously running task if necessary. If all eligible tasks have the same priority, the scheduler defaults to a round robin order. Tasks can be defined, started, stopped, and their priority can be modified dynamically through task control operators that are directly accessible from high level constructs.

Communication or synchronization between tasks is also done directly in high level language with a formal signaling mechanism called a significant event. Tasks send and receive information through this memory location. While operators

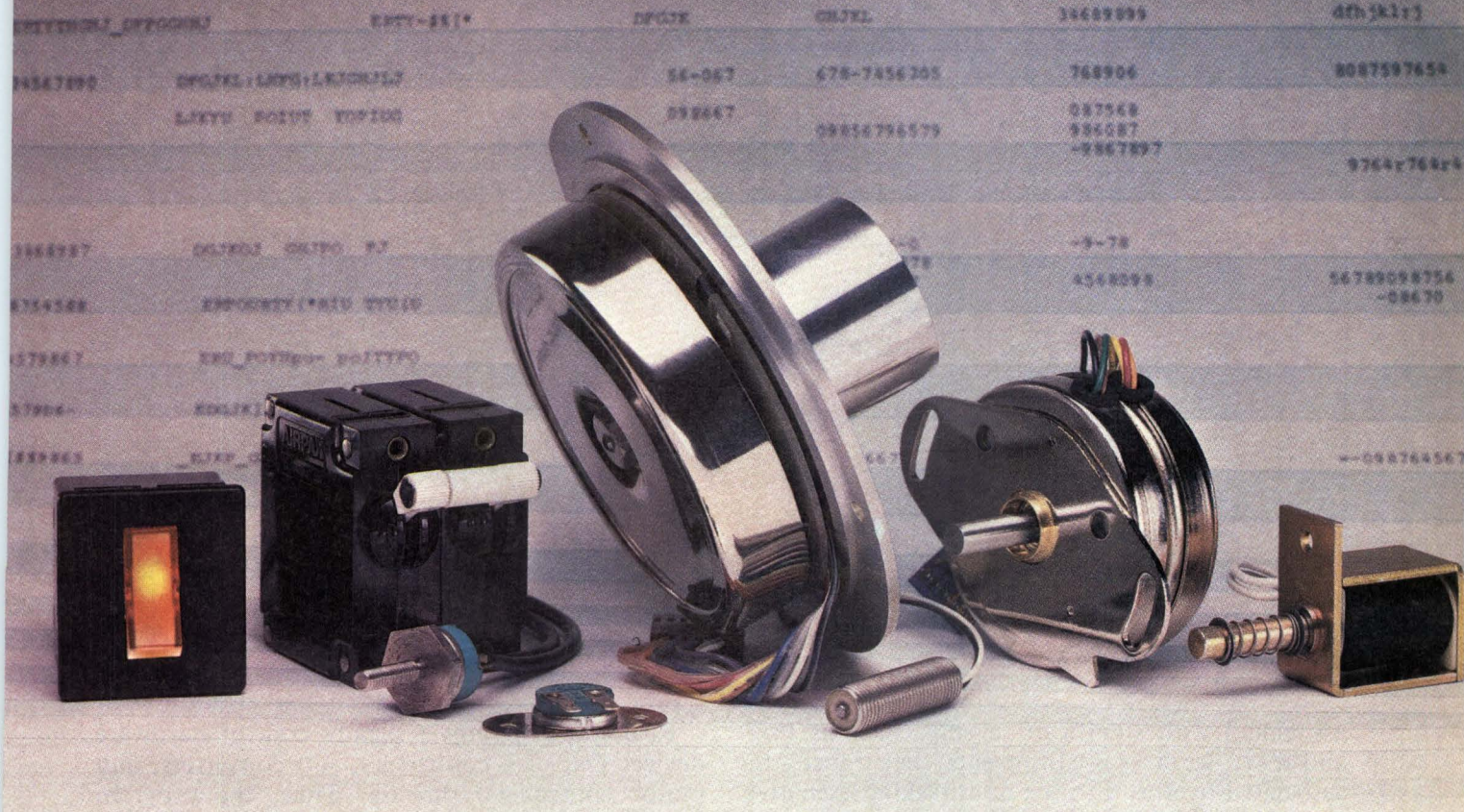

**We have the
components that
make your disc
drive drive, your
printer print,
etc., etc.**

We have the electromechanical components you need for your computers and peripherals. And the responsiveness you need to keep your production rolling.

For memory units, we supply solenoids and a complete line of brushless DC motors designed for 5¼" to 18" disc drives. And linear actuators that position read/write heads in precise digital steps.

For printers, we make rotary steppers and subfractional HP motors, and magnetic pick-ups.

For microcomputers, minis and mainframes, Airpax magnetic circuit breakers assure positive protection. They're unaffected by ambient temperature, and serve the dual function of power switch and overload protection.

And Airpax thermostats monitor cabinet temperatures, and shut down systems instantly when overheat threatens sensitive circuits.

You can select from our thousands of standard models. Or we'll create a custom model for you, and produce a few dozen for prototypes, or millions for a production run.

Ask us for engineering data. Airpax Corporation, a North American Philips Company, W. Johnson Ave., Box A, Cheshire, CT 06410. (203) 272-0301.

AIRPAX®
We give you control.

TABLE 2

ISRs and Significant Events

```

> % ADC Interrupt Service Routine
> 'READ_ADC :
1 >     ADC_Loc @ ADC_EVENT !
1 >     ADC_EVENT POST
1 >     ;
>
>
> 'READ_ADC 'ADC_ISR ISR
>
>
> %Display Task
>
>
> 'DISPLAY :
1 >     REPEAT
2 >         0 ADC_EVENT WAIT =
2 >         ADC_EVENT OI
2 >     FOREVER
1 >     ;
>
>
> 10. 20. 20. 'DISPLAY D_TASK TASK
>
>

```

associated with significant events, such as POST and WAIT, let tasks use the events, they transfer the associated overhead to the multitasking executive. A task waiting for a specified event to occur is suspended and imposes no load on the system.

Another task or interrupt service routine can signal an event (receipt of a character, end of a sector search, closing of a solenoid, etc) with the POST operator. POST causes a search of the list of WAITING tasks, to see if any are waiting for that event. If so, they are activated when they have the highest priority. Table 2 shows an interrupt service routine and a task communicating, using significant events. The interrupt routine operator, READ ADC, gets a value from an A-D converter channel, stores it in a significant event cell, and then posts the event. The display task, D TASK, is suspended while it waits for the event to occur. When ADC EVENT is posted, D TASK awakens, displays the ADC value, and clears the event cell.

Realtime programs typically control hardware devices (eg, disk controllers, A-D converters, and motor controllers) directly. Thus, the program must be able to address hardware ports and interpret and manipulate individual bits in a device control word. Bits can be tested, modified, shifted, and rotated directly in high level language. Hardware ports at explicit locations can be given symbolic names for convenience. Special operators control initialization, the enabling and disabling of interrupts, and interfacing a system clock.

Realtime data structures

Common predefined data types include constants, scalars (both static and dynamic), and vectors. Realtime programmers find certain complex data types useful because they occur in many realtime applications. However, programmers must spend a great deal of time coding and debugging, using the basic constructs of a language. In Sphere, these

TABLE 3

FIFOs and LIFOs

```

> ADV
> HEX
> 64 'INBUFFER FIFO
> 25 TO INBUFFER = 64
> 50 TO INBUFFER = 63
> 75 TO INBUFFER = 62
> INBUFFER = = 3 25
> INBUFFER = = 2 50
> INBUFFER = = 1 75
> INBUFFER = 0
>
>
> 24 'TEMPSTACK LIFO
> 10 TO TEMPSTACK = 24
> 20 TO TEMPSTACK = 23
> TEMPSTACK = 2 20
> TEMPSTACK = 1 10

```

structures—first in, first outs (FIFOs), last in, first outs (LIFOs), and logic device emulators—are pre-defined. Thus, the programmer has a ready-made set of data objects that fit the realtime environment.

FIFO queues are useful for I/O data buffering, especially between interrupt service routines and modules receiving data (Table 3). They can isolate the timing dependencies between device drivers and high program layers. LIFO stacks are used within modules to provide a local, dynamically allocated data structure for temporary storage workspace. This is an effective way to allocate additional working space, because routines remain reentrant and are therefore available to multiple concurrent tasks. Space allocation and pointer manipulation are managed transparently through associated operators.

Logic device emulator operators allow programmable logic arrays (PLAs) and programmable logic sequencers (PLSs)—finite state machines—to be emulated in software. This is useful for coding algorithms expressed in state machine notation, such as device controllers. Conversion to code is straightforward and results in a compact table driven procedure. Fig 1(a) shows a very simple PLS for a motor controller. The input to the controller is a 2-bit field, where D0 is a STOP (0) or a GO (1) command, and D1 is a phase lock (1 = locked) indicator. The state diagram shows the transitions for

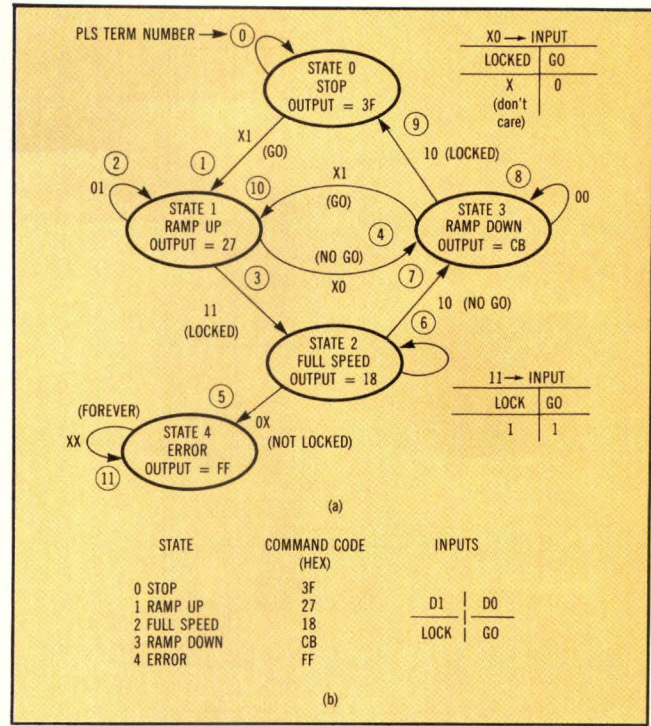

Fig 1 This state diagram (a) describes the possible actions of a software motor controller and the possible inputs (b) that control the changes of the state.

the controller based on the input bits. The controller is phase locked when the motor is at a constant velocity, but loses lock when the speed changes. Controller hardware requires a unique

TABLE 4
State Programmable Logic Sequence

```

> % Argument order for PLS:
> % S1 term number (top of stack)
> % S2 input mask
> % S3 input pattern
> % S4 state mask
> % S5 state pattern
> % S6 next state
> % S7 output
> ADV % invoke ADV vocabulary
> HEX % set hex radix
> 11. 'CONTROL PLS % define PLS
> %
> % Output Next State Smask Input lmask Term TO PLS
> 3F 0 0 OFF 0 1 0. TO CONTROL
> 3F 1 0 OFF 1 1 1. TO CONTROL
> 27 1 1 OFF 1 3 2. TO CONTROL
> 27 2 1 OFF 3 3 3. TO CONTROL
> 27 3 1 OFF 0 1 4. TO CONTROL
> 18 4 2 OFF 0 2 5. TO CONTROL
> 18 2 2 OFF 3 3 6. TO CONTROL
> 18 3 2 OFF 2 3 7. TO CONTROL
> OCB 3 3 OFF 0 3 8. TO CONTROL
> OCB 0 3 OFF 2 3 9. TO CONTROL
> OCB 1 3 OFF 1 1 10. TO CONTROL
> OFF 4 4 OFF 0 0 11. TO CONTROL
>
>
> 'EXECUTE:
> REPEAT % repeat
> STATUS @ CONTROL CREG ! % CREG := CONTROL (STATUS)
> FOREVER % forever
> ;

```

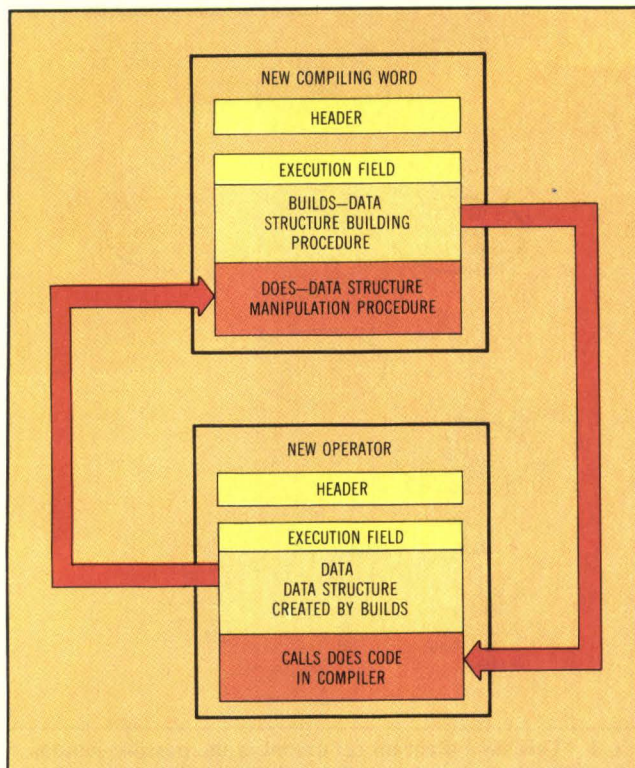

Fig 2 In building a new type of operator, a new compiling word is created using the BUILDS . . . DOES primitive. When an instance of the new operator is created, it calls the BUILDS part of the compiling word to define data structures. When it is executed, it calls the DOES part to manipulate the data.

command code for each possible state. An error occurs if the controller loses phase lock at an inappropriate time.

In Table 4, the contents of the PLS, named CONTROL, are listed as the following: the term number, an input mask, the current input, a state mask, the current state, the next state, and the current out-

put. The CONTROL PLS is used in the EXECUTE operator of Table 4. The motor status is read from a variable, STATUS, and becomes the input to CONTROL. The PLS searches the definition table for a matching input (after applying the input mask) and current state. When a match is found, the corresponding output is returned, and the PLS steps to the corresponding next state in the table.

Extensibility through meta-compiling

As previously mentioned, new operators and data structures are added by using the defining operators. Another level of extensibility that allows an operator to define entirely new classes of objects beyond those provided with the basic system is also available. This is possible because, unlike most languages that use a single compiler with a predefined feature set, Sphere is composed of a large number of very small, special purpose compilers (compiling words). There is one for each data type, in addition to the construct that defines new operators.

Some languages, Pascal and PL/I in particular, allow new data types to be added to make the language better fit the application. As with other procedures, these procedures associated with the new data structures are coded and distinct from the data structures. Sphere extends the notion by encapsulating both the data structure and managing procedures within a data object. Once created (by defining a new compiling word), new instances of the data object can be created at will, with the internal details completely hidden from the calling modules. The only access to the data structure is through the defined object interface.

New compiling words (and therefore new data objects) are created with the BUILDS...DOES

TABLE 5
Defining the Bitset Data Object

```

> 'BITSET : BUILDS
>           2 VAR+
>           D
>           DOES
>           @ MODE @
>           CASE
>           4 { 1 ROT ROTATE NOT SWAP ANDW }
>           5 { 1 ROT ROTATE SWAP ORW }
>           6 { RADIX @ SWAP BIN ? RADIX ! }
>           7 { 1 ROT ROTATE SWAP @ AND
>           NEZ
>           IFT " TRUE"
>           ELSE " FALSE"
>           ENDF }
>           END MODE 0! ;
>
> % Defining an Instance of BITSET
> 'FLAG BITSET
> 'SET      : 5 MODE ! ;
> 'CLEAR    : 4 MODE ! ;
> 'EXAM     : 6 MODE ! ;
> 'TEST     : 7 MODE ! ;
% builds data structure
% allocates one cell (2 bytes)
% places address in dictionary
% execution behavior
% celladdr mode
% mode = ?
% clear bit
% set bit
% display cell
% test bit and
% print
% "true" or
% "false"
% reset mode
% and exit
% create a bitset called FLAG
% assign modes as operators

```

construct (Fig 2). This defines a new compiling word in two parts. The first part, BUILDS, defines the characteristics of the data structure(s) created each time the new compiling word is invoked. Since BUILDS is actually a compiled operator that executes separately, it can receive arguments that modify the characteristics of data structure instance. For example, an argument of a new compiling word that creates a two-dimensional vector can specify the number of elements in the new vector.

The DOES part of the structure specifies actions performed by the objects that are created by the new compiling word. This is the procedural part of the data object. For example, a two-dimensional vector so created might return the address (or contents) of element (i,j) when the arguments i and j are provided. The DOES part of the compiler definition specifies the procedure that uses i and j to look up the appropriate matrix element. DOES specification procedures can incorporate elaborate features (out-of-bounds checking, scalar, or matrix multiplication, etc). As a result, the programmer can customize the system to create an application-specific language.

Meta-compilers build complex data objects

A common data structure in realtime programs is the 1-bit flag. There are usually many in a program to keep track of various operating states, or to control external devices through control registers. Although a single-bit (instead of a byte or word) requires more overhead, it is preferred in small applications because RAM space is very precious (eg, in single-chip controllers like the 8051).

To use single-bit flags, the programmer must either deal with locations and bit masks explicitly, or create a special routine to manipulate flags and a data structure to associate locations and masks with each symbolic flag reference. The first approach is awkward and prone to error. The second requires constant maintenance of the flag definition data structure as the various flags are added, deleted, or moved.

Meta-compiling allows the programmer to define a new compiling word that automatically creates and manipulates bit flags. Table 5 shows a new compiling word that creates a data object called BITSET. The BITSET data object is one cell (2 bytes) containing 16 flags. Each flag can be set, cleared, tested, or examined by setting the appropriate mode before accessing the BITSET and indicating the desired bit position (BITSET 0-15). BITSETS are referred to symbolically. Space for each new

> ET 7 FLAG SET 2 FLAG SET 4 FLAG	% set bits 7, 2 and 4
> EXAM FLAG 10010100	% examine FLAG
> CLEAR 4 FLAG EXAM FLAG 10000100	% clear bit 4, examine
> TEST 4 FLAG FALSE	% test bit 4
> TEST 7 FLAG TRUE	% test bit 7
>	%
>	%
> 3 'DRIVENB CONST	% define constants
> 5 'DIRSENS CONST	%
>	%
>	%
> SET DRIVENB FLAG	% set drive enable bit
> TEST DIRSENS FLAG FALSE	% test direction sense

BITSET is automatically allocated when it is created.

The BUILDS part of the definition allocates space for a new BITSET and places its address in the dictionary for later reference. The DOES part performs one of four actions (set, clear, test, or display), depending on the value of the variable MODE. The desired bit position is specified as part of a call to the newly created BITSET operator. Four operators that set the state of MODE are also defined for convenience. For example, a new BITSET, called FLAG, is created (Table 6). In this example, bits 7, 4, and 2 of FLAG are set, and then FLAG is examined. Bit 4 is then cleared and FLAG is examined again, showing the result. Bits 4 and 7 are then tested showing the results FALSE and TRUE, respectively. By creating symbolic constants (DRIVENB, DIRSENS), FLAG manipulation can be done entirely with symbols.

Realtime software developers have traditionally written their code in assembly language because of the need for performance and hardware control. They expect to rewrite code for each target system with a different processor or hardware interface. Realtime applications can be made portable across processor and systems by supplying all the required functions as high level language constructs, independent of the underlying processor instruction set. The programming system also includes a generalized interface to character I/O and mass storage, for added portability. By providing compatible environments for the major processor families, it allows high performance realtime programs to be moved at will among target systems. This means that system development can begin even before the target processor is selected. Upgraded systems can also incorporate new processors without software redevelopment.

Please rate the value of this article to you by circling the appropriate number in the "Editorial Score Box" on the Inquiry Card.

High 722

Average 723

Low 724

Leapfrog



to 32 bits!

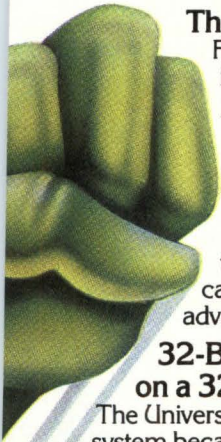

The 32-Bit Advantage

For OEMs and system integrators, getting the jump on the competition means leapfrogging to the most advanced technology available. Today, that means making the jump to 32-bit architecture. Now. When it can give you a decisive advantage.

32-Bit Memory on a 32-Bit Bus

The Universe 68/05 is a true 32-bit system because it handles 32-bit data transfers in parallel on its 20Mb/sec VERSAbus, while most 68000-based machines are still limping along with 16-bit buses. With the next generation of processors (like the MC68020), a full 32-bit bus will be a requirement on *all* systems. VERSAbus is there now, and it's non-proprietary.

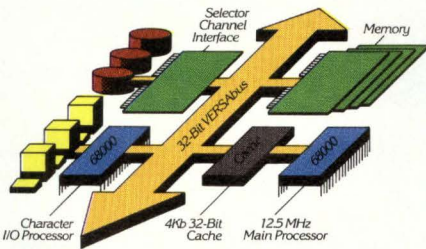

32-Bit Cache, 12.5MHz 68000

Our new Universe 68/05 is the first general-purpose computer built and delivered using the new 12.5MHz 68000 microprocessor. Its 4Kb 32-bit cache memory virtually eliminates wait states, while a separate 68000 I/O processor offloads the main 68000. Its MIPS rate—1.25 million instructions per second—outstrips a VAX 11/750 that costs several times as much.

UNOS is a trademark of Charles River Data Systems, Inc. UNIX is a trademark of Bell Laboratories. VERSAbus is a trademark of Motorola. VAX is a trademark of Digital Equipment Corporation.

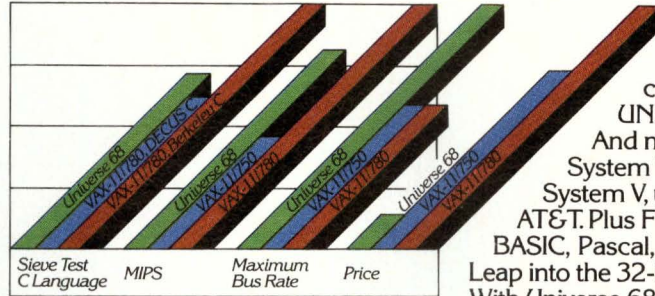

Universe 68 provides performance comparable to VAX, at a price far below VAX.

32/64-Bit Hardware Floating Point

Our new IEEE-format hardware floating point unit handles 32- and 64-bit operands fast. In fact, with floating point performance in the 40-50K flops range, it holds its own very nicely with VAX-level machines. Yet the Universe 68's price tag is only a fraction of a VAX's.

The First 32-Bit System Under \$10,000

The Universe 68/05's under-\$10,000 OEM-quantity-one price includes 32-bit central processor, 10Mb Winchester, 1.26Mb floppy, 256Kb RAM (expandable to 3Mb), and four serial I/O ports (expandable to 64). You can build multiterminal systems around a 68/05 at a cost-per-user that will embarrass workstation systems. For even more horsepower and expandability, you can hop over to the compatible Universe 68/37 or 47.

The 32-Bit, Real-Time, Bell UNIX UNOS, our multi-user, multi-language



operating system, brings real-time, transaction-oriented capabilities to the UNIX-compatible world. And now we also offer CRDS System V, a derivative of UNIX System V, under license from AT&T. Plus Fortran, RM/COBOL, BASIC, Pascal, C, and DBMS. Leap into the 32-bit future now. With Universe 68 from Charles River Data Systems.

UNIXTM

NOW RUNS ON

UNOSTM

Send me "The Insider's Guide to the Universe," an informative 24-page discussion of the technical concepts behind the Universe 68 family of computers.

Have a sales engineer call.

Name _____

Company _____

Address _____

City _____ State _____ Zip _____

Telephone _____

Return to Charles River Data Systems,
983 Concord St., Framingham, MA 01701
(617) 655-1800

CD-1

CHARLES RIVER DATA SYSTEMS

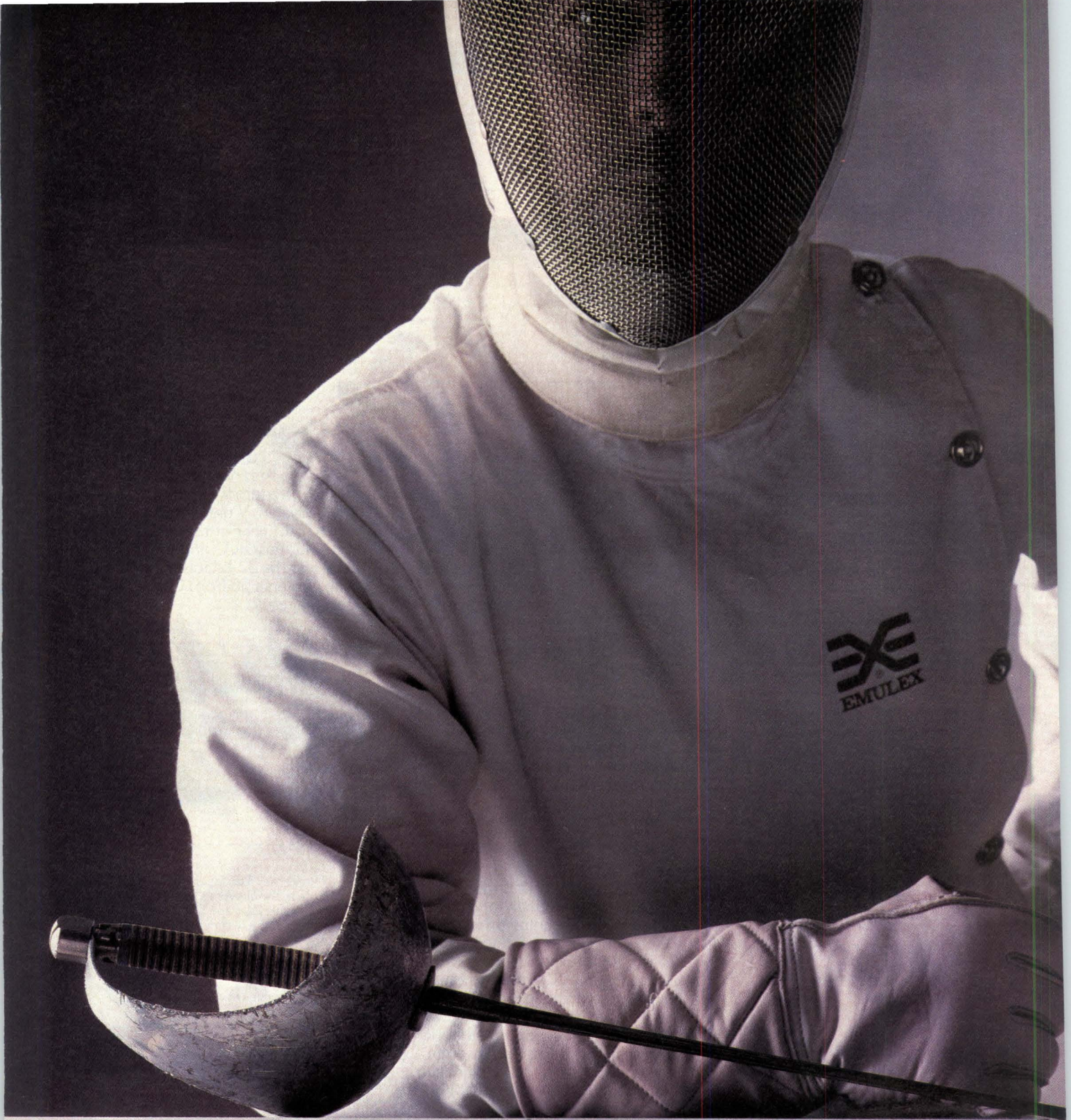

EMULEX



SABRE

Storage and backup problems on your QBus? SABRE™ has a sharp solution.

SABRE™ is a cut above anything on the market. It's a new concept in high-capacity, high-performance mass storage. A 5¼" Winchester/cartridge disk package for use with operating systems that run on DEC LSI-11 through 11/23+ microcomputers. SABRE's an innovative, RL02 software transparent storage alternative that puts 41.6 Mbytes on-line and delivers balanced backup through a versatile, removable cartridge disk. All in a compact, rack-mountable package.

Standard interfaces/transparent software.

SABRE hits the mark for reliable, high-speed, low-cost storage with convenient, efficient backup. Its UC01 host adapter plugs into any single-quad width QBus slot, and provides the Small Computer System Interface (SCSI) system-level bus for SABRE and up to five additional I/O devices. Through exact RL02 emulation, SABRE runs existing operating and diagnostic software as is. With logical RL02 images on both the fixed and removable media drives, volume backup is a snap.

Hard disk backup performance.

The ruggedized cartridge drive provides hard disk backup performance and reliability. Many times faster than either floppies or tape, it also provides the versatility to handle program entry, data storage and can function as a system disk. Overall, the 5¼" Winchester/cartridge disk combination gives system-level performance which *exceeds* multiple RL02's in many applications.

Efficient system packaging.

Space-saving SABRE is 5¼" high, slips into any standard 19" Retma enclosure and comes complete with power supply, host adapter and connecting cables. It needs one-eighth the space and draws one-quarter of the power of four RL02's. Further, SABRE slashes hardware and installation costs by eliminating the need for a separate system bootstrap, bus terminator and clock control board.

For more information on SABRE or any of the high-quality Emulex communications, disk, tape and packaged subsystem products, call toll-free (800) 854-7112. In California (714) 662-5600.

SABRE's Features

Size	Compact 5¼" height x 19" width package contains 31.2 MB (3xRL02) 5¼" Winchester disk and 10.4 MB (1xRL02) removable 8" cartridge disk.
Capacity	Equivalent to four (4) DEC RL02's.
Speed	Overall performance significantly increased over tape and floppies, especially in throughput and backup time.
Transparency	Runs standard RL02 diagnostics and operating software.
Flexibility	Removable cartridge disk; SCSI Bus interface allows up to five (5) I/O devices; single-board host adapter.
Reliability/Durability	Winchester technology; ruggedized cartridge disk construction; shock mounts; hermetically sealed HDA for protection against contamination.
Price/Performance	Lower cost per box and per MB in virtually all applications.

GSA Contract #: GSOOK8401S5575 ™SABRE is a trademark of Emulex Corporation. DEC, LSI and QBus are trademarks of Digital Equipment Corporation.



3545 Harbor Blvd., P.O. Box 6725,
Costa Mesa, California 92626.

The genuine alternative.

CIRCLE 107

**The Only Way
You Can Get Q-BUS* Compatibility
And Interface Flexibility
With ANY or ALL These
5¼" Winchester Drives
is With
These Two Controllers**

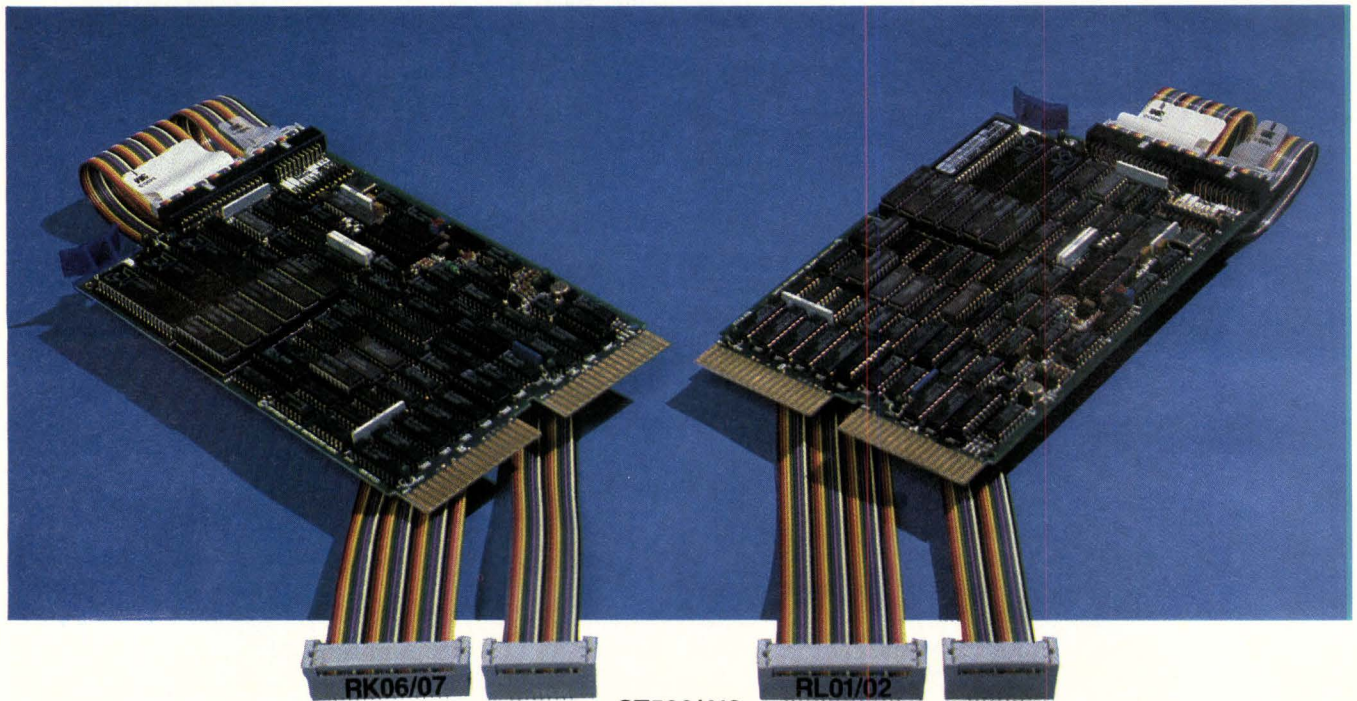

AMPEX	FUTITSU	MINISCRIBE	SEAGATE
ATASI	IMI	MPI (Micro Peripherals)	SHUGART
ATHENAEUM	MAXTOR	NEC	SYQUEST
CDC	MEMOREX	NISSEI SANGYO	TANDON
CMI	MICROPOLIS	PRIAM	TOKYO ELECTRIC
COGITO	MICROSCIENCE	QUANTUM	TULIN
DISCTRON (RMS)	INTERNATIONAL	RODIME	VERTEX

THE ONLY WAY!

You can't get it with DEC. Or any other independent controller manufacturer.

That's because these controllers feature DILOG's exclusive Universal Formatting™. That means you can mix or match any two compatible drives (ST506/412), regardless of heads, parameters, capacity, etc. This powerful feature offers you real flexibility in drive selection now...and expansion in the future. It's simple as unplugging one drive and plugging in another.

Model DQ615

- RK06/07 compatible
- Formatted drive capabilities 222.4 MB
- Maximum 8 logical units—two physical

Model DQ614

- RL01/02 compatible
- Formatted drive capacities 41.6 MB
- Maximum 4 logical units—two physical

They both have enhanced 32-bit ECC, 22-bit addressing and RT-11, RSX-11, RSTS and TSX-Plus.

DILOG Universal Formatting™ is also offered for the largest SMD I/O drives. And for your back up there are controllers for ½" tape, ¼" cassette and 5¼" and 8" floppy drives.

Contact your nearest sales office, distributor or DILOG directly for complete data on the way to unmatched Q-BUS compatibility and drive flexibility... THE ONLY WAY!



DISTRIBUTED LOGIC CORPORATION

12800 Garden Grove Blvd. ■ Garden Grove, CA 92643 ■ (714) 534-8950 ■ TLX 681399
64-A White Street ■ Red Bank, NJ 07701 ■ (201) 530-0044
12 Temple Square ■ Aylesbury, Buckinghamshire, England HP 20 2QL ■ 44 (0296) 84101 ■ TLX 837038



NEW TOOLS BUILD MICROSYSTEMS

Designing modern 16-bit computer systems requires a new set of tools. Modularity and a variety of realtime tools increase productivity.

by Larry Badagliacca

A highly structured, controlled environment leaves little or no room for individual instruments jury-rigged to run more or less together. It does involve a mini or mainframe computer for software development, surrounded by multiple, integrated workstations (eg, Dolch's ATLAS system) as nodes. In-circuit emulators, stimulus instruments (such as pattern generators), and logic analyzers may all be linked in a consistent, realtime way that defines their interactions according to the controls available and the events sensed. A common data base is provided for all development team members, and file and display formats are standardized for ease of use by any team member, regardless of the data origin.

Such an approach provides for tight project management and control. It is in direct contrast to today's team effort in which the various team members may each have private copies of data and programs, with little or no consistency among the various copies.

The modern development process

Microprocessor-based systems apply the modern development process to larger and more complicated

problems. System resources now include multiple 8- and 16-bit microprocessors, larger memories, and more special function chips such as math and floating point processors, communication processors, and text processing chips.

Even though the computational power of 8-bit microprocessors is frequently adequate, these devices today are playing a transitional role, by paving the way for 16-bit devices. In some cases, the 8-bit processors are still used because of the large software base available, or because of the great variety of specialized peripheral chips available. On the other hand, the demand for more memory has created an equivalent demand for processors that can address the required memory directly.

One significant consequence of the new systems' complexity is that it is no longer efficient for one person to design and implement a complete system—the scope of the system is too large and the interactions are too complex. Instead, several people—a team—now work together to develop a system.

Another consequence of this complexity is that the use of the larger memories means that more code is being generated. For this reason, efficient code generation is needed to keep the development process short and economical. Both factors—team effort and the need for efficient code generation—result in a need for modularity as well as hardware and software standards. Modularity and standards allow development team members to concentrate on the piece of the job for which they are responsible, and ensure that the finished pieces can be successfully integrated into a common whole.

Larry Badagliacca is vice president of engineering at Dolch Logic Instruments, Inc, 3052 Orchard Dr, San Jose, CA 95134. He holds a BA from the University of California at Los Angeles.

At the hardware level, the new systems need standard bus structures and interfaces to the system under test, and other standards (protocols) that define the logical interactions, timing, logic levels, etc. At the software level, there is a need for structured programs in which a dedicated module performs each function. There must be standard methods of passing parameters and data structures from module to module, a common data base on which all the modules operate, and software tools to optimize system memory use and execution speed.

Developers also need to generate small amounts of dedicated, throwaway code—code written to test small portions of the system that will not become part of the higher level, total test program. Older, smaller systems could be developed by one person able to optimize system performance. In contrast, the newer, larger systems prevent any one person—except perhaps the project manager—from seeing a clear picture of the whole. This means that the systems being developed must be broken down into separate modules, which until integration into the whole, remain as quasi-independent functions to be developed by themselves. This same modular approach also makes debugging easier.

As a result, the payoffs and problems are now much larger. The early systems were applied to simpler, less consequential uses such as controlling a single motor. On the other hand, the new systems are applied to far more complex uses, such as controlling an entire production line.

Linked development tool functions

Many times, hardware and software modules must be tested before the interfaces are available. This requires a stimulus source to simulate the inputs to the controller. Physical modularity also creates a need to link together various tools (ie, in-circuit emulators, and logic analyzers) to monitor the various modules and their interactions. There may be several interacting processes at work among the modules being investigated, so the designer may need to look at the processes and their interactions both simultaneously and individually, to identify and correct problems. Multiple logic analyzers connected to the development system make this possible.

Multiple instruments, in turn, have created a need for new kinds of instrument interaction and linking. First, the software development environment (on a mini or mainframe) must communicate with the actual target system via the test/debug instrumentation. Such communications now make use of traditional methods, essentially the RS-232-C serial interface. But such methods are not designed for distributed networks, do not permit realtime interaction, and typically give only a point-to-point type of communication. Information flows to and

from the host to a single emulator, or to a single logic analyzer. Besides being limited to communications between two devices, this type of interface, the RS-232-C in particular, is painfully slow when large amounts of code must be transferred.

The most significant new requirement is that there be realtime interaction among all the various test-support units such as analyzers, emulators, stimulators, etc. This is a serious problem, since parts are not usually available from a single vendor, and it is not easy to make the instruments work together.

Integrating the workstation

In software development, the integrated workstation functions, first of all, as a terminal interfacing the host—a minicomputer or mainframe—on which the software is developed. Users operating this “terminal” have a direct connection to the software development environment for editing, assembling, compiling, checking syntax, etc.

Another mode lets the designer download the developed software into the workstation or an emulator, via communication tools ranging from a simple RS-232-C interface to a high performance local area network (LAN). Once in the target system’s code debugging environment, the workstation allows the various tools to be tied together in a consistent, realtime way.

Dolch’s adaptive test and logic analysis system (ATLAS) is a family of instrumentation front ends combined into a single, integrated, digital workstation. The ATLAS mainframe itself combines a general purpose microcomputer, the MP/M operating system, and a high speed interface (the link bus) into a system in which the plug-in modules operate as intelligent multi-users. The modules can interact among themselves, with the

The integrated workstation allows event detection capabilities to be combined in a variety of ways.

target system under development/test in real time, and also with the mainframe controller and other systems on the development network. A double-wide CRT screen provides split-screen displays that simultaneously show data or timing diagrams, with menus, comments, or test results. (See Fig 1.)

The ATLAS system does this using its link bus, which allows each plug-in instrument to sense realtime events detected in other instruments, and to combine them in logical ways. Historically, such realtime events have been called by different names in different instruments. In in-circuit emulators, they have been called breakpoints, because their most common use was to stop or start the emulation process. In logic analyzers, these same events

PERFORMANCE ARCHITECTURE: Data Acquisition and Control. Multi-User Computation. High-Performance Graphics. All Simultaneously.

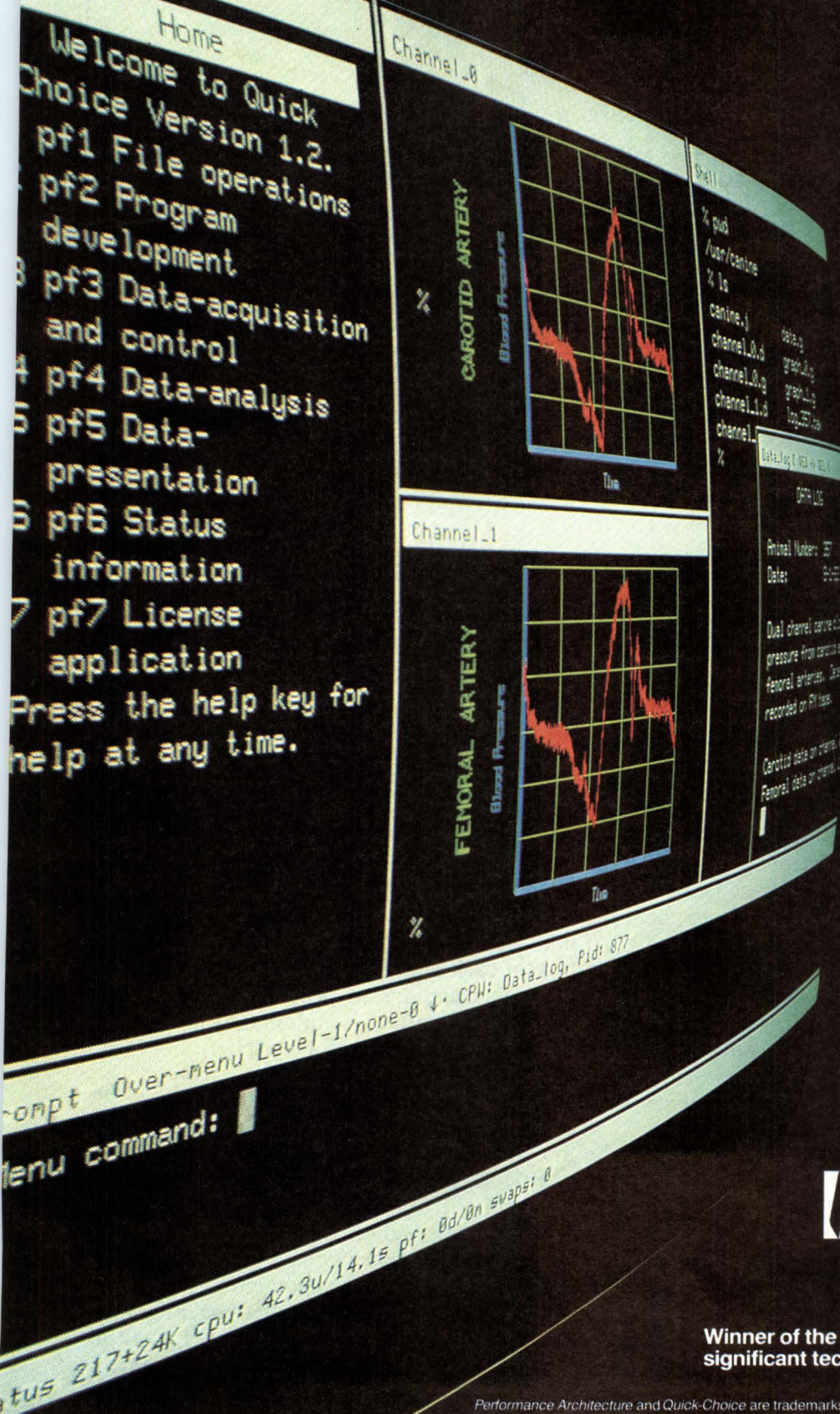

Masscomp's unique triple-bus Performance Architecture™ delivers unequalled system price/performance. With its dual-processor CPU and up to 7 megabytes ECC memory, the Masscomp MC-500 offers scientists and engineers outstanding computation power. With the addition of Masscomp-designed floating-point and array processors, throughput is even further enhanced.

The MC-500 runs a virtual memory, real-time UNIX™ operating system with Ethernet™ support. Supported languages include C, FORTRAN 77, and Pascal-2™. The Quick-Choice™ multiple-window user interface offers menu-driven access to system functions.

Key system capabilities include:

DATA ACQUISITION AND CONTROL

- Bit-slice Data Acquisition and Control Processor
- One million 12-bit analog samples/second
- One microsecond external-event response

MULTI-USER COMPUTATION

- 32-bit CPU with 4K byte cache
- 16 megabyte virtual address space
- 7 millisecond 1024-point complex FFT

HIGH-PERFORMANCE GRAPHICS

- Independent 32-bit graphics processors
- 1024 x 800 x 2 x 1 pixel monochrome graphics
- 832 x 600 x 2 x 10 pixel color graphics

For more information on how the MC-500 is delivering results in industrial, university, government, and medical applications, call 1-800-451-1824.



MASSCOMP

One Technology Park
Westford, Massachusetts 01886
TWX: ESL 196520
Telex: 704353
Cable: MASSCOMP

Winner of the 1983 I-R 100 Award as one of the most significant technical products of the year.

Performance Architecture and Quick-Choice are trademarks of the Massachusetts Computer Corp. UNIX is a trademark of Bell Laboratories. Pascal-2 is a trademark of Oregon Software. Ethernet is a trademark of the Xerox Corp.

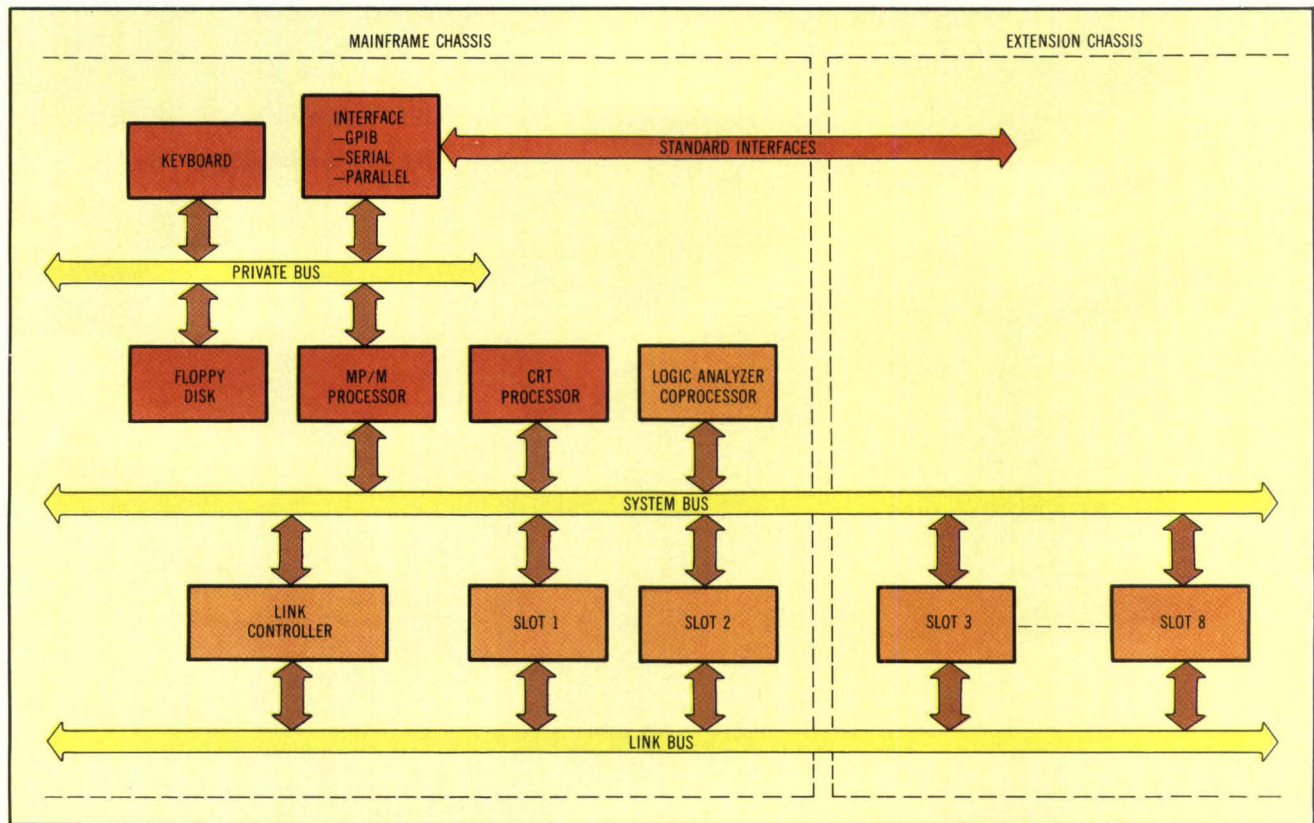

Fig 1 The ATLAS system consists of an extension chassis with six expansion slots for instruments, and a mainframe chassis with three microprocessors for MP/M, CRT, and logic analysis processing and control. The private bus handles interfacing tasks to computer peripherals (disk drives, etc). The system bus controls the communications between the two chassis and ties together all the plug-ins, the three microprocessors, the link controller, and its associated link bus.

are called triggers. These are semantic differences, however. What is important is the ability to detect all such events in a realtime hardware system, even though they may assume myriad forms.

Furthermore, each instrument within the integrated workstation detects events at a level of complexity appropriate to that instrument. It may be capable of multiple trigger levels, pass counts within levels, sequencing of the events to be detected, or whatever function is needed.

Finally, the integrated workstation allows all these event detection capabilities to be combined in a variety of ways. This lets the workstation link those events to the various test system units that need the information.

If the various plug-ins and other instruments must influence each other in real time, ATLAS users can use the system's link function. This function detects events from the instruments attached to ATLAS to determine the start and stop sequences for all involved. Thus, events that occur in one plug-in (eg, a logic analyzer's triggers) can influence the process in another plug-in such as an emulator.

The link function may be best compared with the sequential trigger of a logic analyzer. In a sequential trigger, the time interval between starting and stopping the analyzer is divided into steps called

trigger levels, and an advance from one level to another is signalled by trigger events.

Analogously, in ATLAS the interval between the initialization of all plug-ins and the time they finish their tasks is divided into steps called link levels. A link event occurring in a plug-in causes an advance to the next link level, and other plug-ins can be signalled to begin a specific action called a link reaction. Figs 2 and 3 depict this process.

Link events and link reactions are separately defined for each plug-in, and each plug-in stores the information necessary to program the link function. The information is automatically accessed whenever ATLAS' link menu is selected.

The integrated workstation

Two examples will demonstrate the concept of the integrated workstation. Both examples are of tasks difficult for today's typical instrumentations. The first example is of a relatively simple stimulus interaction; the second, much more complex, shows how several elements may be viewed simultaneously in a logic analyzer/emulator interaction.

In the first example, a logic analyzer plug-in is set to trigger at the occurrence of an I/O request to an external device. When it detects this event, it supplies an input signal to ATLAS' link bus. Using the system's link menu, the users have also

Retro-Graphics® and DEC.



Three models now deliver 800-by-480 resolution with DEC ReGIS and Tektronix emulation.

Whether you're doing business charts or technical diagrams, Retro-Graphics enhancements deliver the highest bit-map resolution and widest variety of protocols available on DEC™ displays.

With our 800-by-480 resolution, graphs — both displayed and printed — come out sharply defined. More professional. Without the exaggerated "stair-stepping" experienced on low-resolution terminals.

But most important is our range of graphics emulations.

With one Retro-Graphics model, for instance, you can generate point plots and line drawings with Tek® 4014 emulation.

Another employs user-friendly Tek 4027 commands for drawing and filling bar and pie charts.

And the third provides you with DEC's versatile ReGIS protocol as well as 4014 graphing.

With Retro-Graphics, therefore, you can interface to a large selection of name-brand software. PLOT 10™, DISSPLA®, and DEC's DATATRIEVE™, to name but a few.

Retro-Graphics. Now at 30,000+ installations. And backed by full warranty and comprehensive service programs.

Strong reasons for choosing Retro-Graphics over any other for developing the precise lines that make your graph stand apart.

Contact us today for full details, demonstration, and the name of your local DE/DEC dealer — your "one" source for graphics.

Retro-Graphics and DEC.

A choice of Retro-Graphics models.

Retro-Graphics — a PCB assembly — installs in DEC VT100/101/102/131/132™ VDTs and features 800-by-480 resolution, fast 16-bit microprocessing, and multiple I/O.

NEW DQ640 SERIES

- Tek 4014 emulation
- Vector drawing and point plotting
- Low cost — under \$1,300

GEN.II™ DQ650 SERIES

- Tek 4027 and 4014 emulation
- Primitives drawing, solid or pattern fill
- Multiple character sets
- User-friendly commands

Tek/ReGIS DQ650 SERIES

- DEC ReGIS and Tek 4014 emulation
- Primitives drawing, solid or pattern fill
- Compatible with DEC's DATATRIEVE and Tek's PLOT 10

 **DIGITAL
ENGINEERING**

630 Bercut Drive, Sacramento, CA 95814
(916) 447-7600 Telex: 910-367-2009

Retro-Graphics is a registered trademark and GEN.II is a trademark of Digital Engineering, Inc. ©1983 Digital Engineering, Inc.

CIRCLE 110

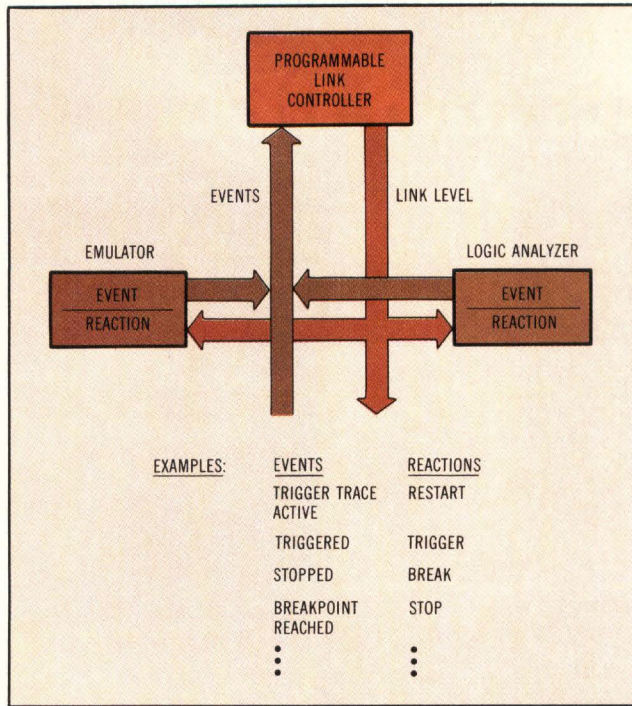

Fig 2 The link bus offers realtime interaction between instruments. Through it, an event occurring at one instrument causes a reaction at another. The logic analyzer can be told to start recording immediately after the emulator has reached a specified breakpoint. Programmed through a separate menu, the link controller can await specified events and trigger reactions elsewhere.

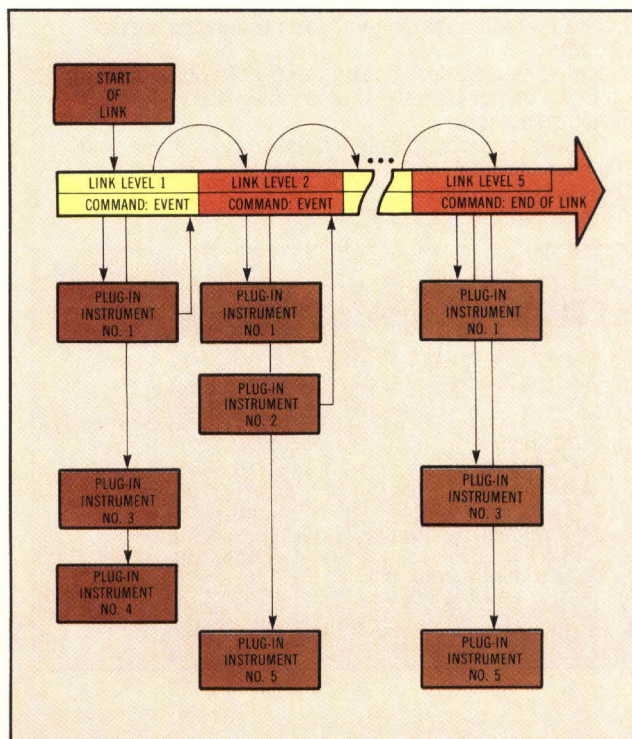

Fig 3 The link process is a sequential one. An event must occur, then a reaction, then a moving-on to the next link level. The start of the link process causes a command to be sent to a group of plug-in instruments. When an event occurs, the system goes to the next level, and so on, up to five link levels.

programmed the pattern generator plug-in to trigger on the occurrence of the event. This trigger then causes the pattern generator to simulate the external device, the desired result.

As a second example, consider a system based on multiple 8- and 16-bit microprocessors, in which the processors communicate with each other across a common bus. Suppose, too, that a problem exists in transferring data from two 8-bit processors to a 16-bit processor.

The test set up is as follows: each 8-bit processor has been connected to a logic analyzer plug-in on the ATLAS system; each analyzer has been set to trigger when a bus transfer is generated by the processor connected to it. A third logic analyzer plug-in, connected to the target systems' internal microprocessor bus, has been set to trigger on the occurrence of an event on the link bus—in particular, the 8-bit transfers in question.

The 8-bit transfers are detected by the plug-in logic analyzers connected to the respective processors, and passed to the ATLAS link bus. These link bus events can be subsequently combined and qualified using conditions local to the analyzer connected to the processor bus to check the bus activity by pass counting, adding bus control signals and/or data patterns, etc.

Look-alikes in the integrated workstation

The power and versatility of the integrated workstations are based in part on file and display format standardization. Standardization allows data transfer among all plug-ins. Standard timing diagrams, data lists, disassemblies, etc permit varied data to be handled in similar ways, and afford the operators a standard way of dealing with the system.

Standardization also allows the systems to display and manipulate realtime events in nonreal time. A pattern can be captured, then used as a stimulus for debugging when the original pattern source may no longer be available. It can even be saved for use in the production test environment. Examination of events in nonreal time also allows multiple sample averaging, generation of histograms for analysis of memory use, determination of the dominant instruction mix, finding where and how the program spends its time, etc.

An individual interface to a shared system, as the integrated workstation affords, brings with it all the advantages of a true individual station, but adds the benefits of multilevel standardization. The software used is guaranteed to be the correct version (through library management and control). The data used is up-to-date (from a shared data base). Compatible file formats provide easy file exchanges. All modules share compatible displays, and all instruments look alike with operating modes that are consistent from one to the other.

In effect, this new approach extends the concept of the laboratory notebook. It offers a common site for the recording of system observations, test results, design notes, manual inputs, etc. The integrated workstation's common data base makes these things possible.

In the new systems, the level of hardware/software complexity already requires multiple instruments to be linked in real time for development and debug. Yet such linking, using even advanced techniques, becomes an extremely complicated process if there is no logical and easily understandable interaction between instruments and functions.

Workstations become more versatile

Software options permit ATLAS to operate as an instrumentation terminal for minicomputers or mainframes. For example, ATLAS can emulate a VT-100 terminal for a VAX or PDP-11 computer, providing a transparent interface between the target system and the computer.

Programs generated on the larger computer can be downloaded to ATLAS for debugging of the target system and integration of its hardware and software. In this fashion, ATLAS can operate on a LAN with other ATLAS systems and/or Dolch logic analyzers, or on a larger central computer host network via RS-232-C or the IEEE 488 bus.

Available for ATLAS are logic analyzers, in-circuit emulators, digital word generators, a serial data analyzer, and a PROM programmer. Each plug-in is supplied with its software on diskette, an operating manual, and its keyboard flip chart. The ATLAS concept and its documentation allow anyone—not just Dolch alone—to design and supply plug-ins.

Using the system's proprietary link bus, only a 10-ns delay is required for one module, such as a logic analyzer, to recognize an event and trigger another module, such as an in-circuit emulator, to trace or control the CPU.

The modular flexibility of the ATLAS system includes logic analysis with 48 channels (at 10 and 20 MHz), 32 channels (at 100 MHz), or 16 channels (at 300 MHz); in-circuit emulation (support of 8- and 16-bit microprocessors); word generation (20 and 100 MHz); PROM programming; and serial data analysis. Finally, the ATLAS mainframe will accept two plug-ins, with six more in an expansion chassis.

Please rate the value of this article to you by circling the appropriate number in the "Editorial Score Box" on the Inquiry Card.

High 725

Average 726

Low 727

EXTEND THE CAPABILITY OF YOUR PC

RTCS ADVANCED OPERATING SYSTEMS AND SOFTWARE DEVELOPMENT TOOLS CAN TAKE YOUR PC TO THE LIMITS OF YOUR IMAGINATION

RTCS/UDI - UNIVERSAL DEVELOPMENT INTERFACE

- Runs Intel Series III software on a PC, XT or any MS-DOS computer.
 - PC / Series III file transfer software included.
 - 100% software compatible with Series III.
 - PCSBC - Upload, download & debug target system (Option).
 - UDEBUG - Onboard debugging tool (Option).
 - Over 800 licensed RTCS/UDI's in use.
- PRICE \$500

PC/IRMX - REAL-TIME MULTIUSER MULTITASKING OPERATING SYSTEM FOR IBM PC

- More versatile than Intel's System 86/330.
 - Intel Utilities, Edit, Link, Locate, Librarian & ASM included.
 - Intel Pascal 86, Fortran 86, PL/M 86 and C 86 Languages optional.
 - Ethernet, GPIB and Hard Disk options.
 - Available for COMPAQ, TI Professional and DEC Rainbow
- PRICE \$2,250

FORCON - BRING DOWN MAIN FRAME FORTRAN PROGRAMS TO RUN ON THE PC

- Pascal, PL/M, Fortran 77/66 and C compatible compilers.
 - Superior object code optimization and in-line 8087 code.
 - Support large arrays (over 64K).
 - Overlay loading.
 - Object modules run on IBM PC and XT.
 - Special large program utilities option.
 - Available for COMPAQ, TI Professional and DEC Rainbow.
- PRICE \$4,850

SOFT SCOPE - HIGH LEVEL SOFTWARE DEBUGGER

- Source code interface.
 - High level Trace, Single Step and Breakpoints.
 - Access to Symbols and Line Numbers.
 - Machine disassembly and Floating Point support.
 - Goes beyond Intel's Pscope.
- PRICE \$995

All RTCS Software products support the 8087 Numeric Data Processor. Soft-Scope is a trademark of Concurrent Sciences, Inc. MS-DOS is a trademark of Microsoft Corp. IRMX is a trademark of Intel Corporation.

RTCS

Distributed in Japan by SYSCON CORP., Tokyo

REAL-TIME COMPUTER SCIENCE CORP. SOFTWARE DEVELOPMENT TOOLS
ADVANCED OPERATING SYSTEMS
P.O. BOX 3000-886, CAMARILLO, CALIFORNIA 93011 • PHONE NO. (805) 482-0333 • TELEX 467897

THE EMULOGIC® ECL-3211.

SCREEN

Automatically updated full-screen display of all registers and system status.

MAPPING

Full-speed, full-range mapping in internal, external, and mixed modes. Single-word resolution. Full-range offsets.

BREAKPOINTS

Eight 78-line real-time logical breakpoints for every chip, concatenated via logical switches and counters.

FAST KEYS

They're fast, direct, and don't get in your way. The most user-friendly operator aid available today.

CF/LOG

Selects screen with all Command File and Log function options.

TRACE

Breakpoint-controlled 511 x 72-bit real-time trace with precise disassembly.

TIME BASE

Multi-sourced time base—internal synthesizer or target clock.

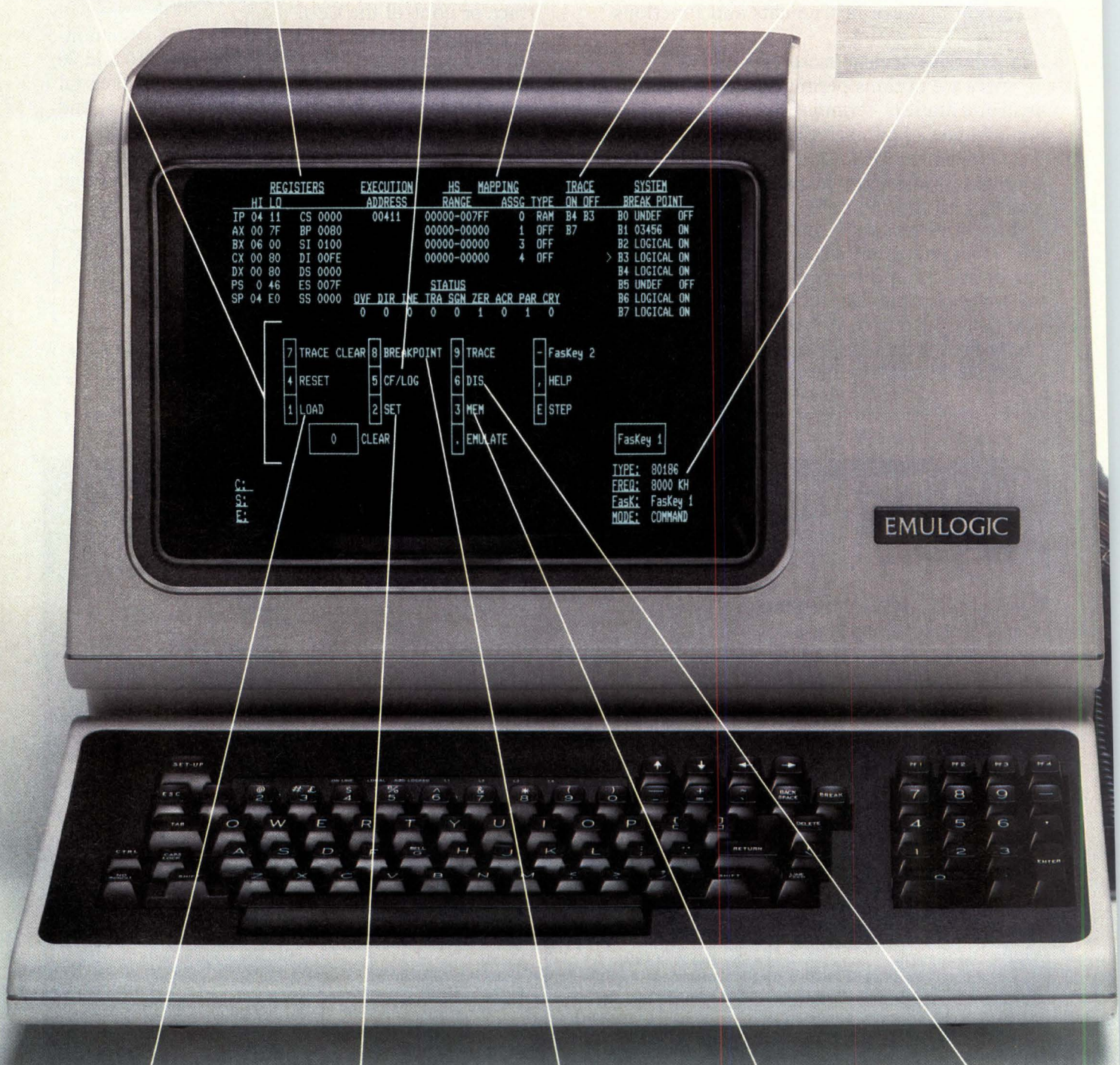

LOAD

Selects LOAD screen with all options.

SET

Selects screen with all SET options.

BREAKPOINT

Selects screen with all BREAKPOINT options.

MEM

Selects screen with all MEMORY options.

DIS

Selects screen with all DISASSEMBLY options.

STILL THE BEST MICROPROCESSOR DEVELOPMENT SYSTEM YOU CAN GET. AT ANY PRICE.

WORLD'S BEST EMULATOR.

It's the best you can buy. Pure and simple.

Built around DEC's LSI-11 CPU's, RT-11, and a full range of DEC options like RL02 hard disks, the Emulogic general purpose emulator supports more chips from more manufacturers better than any other system.

With the ECL-3211 you can find your bugs in the lab, before your customers find them in the field. It lets you probe into things that other systems can't even see. In fact, you probably can't define a condition that the 3211 can't trap. And yet it's easy to use.

"NO-WAIT-STATE" EMULATION.

Up to the full rated speed of every chip with all features implemented. Doesn't steal any interrupts, stack pointers, stack space, or memory space. Handles all types of interrupts in any mapping configuration. Logical switches, counters, and trigger outputs manipulated in real time at no cost to user program.

COMPLETE HELP FACILITIES.

Our new "FAST KEYS" and Advanced Command Syntax make it a snap to learn to use. You don't even have to read the manual to get started.

And once you've used it for one chip, you don't have to learn anything new for the next chip. The screen format is uniform for all chips, and all system functions are the same. All you have to learn is the chip itself.

WORLD'S BEST DEVELOPMENT SOFTWARE.

More powerful and easier to use than any in the field, the software tools available with every ECL-3211 let you develop and debug software as readily as hardware. So system integration gets done effectively and on schedule.

DEC Operating System. RT-11 Version 5 is standard for stand-alone ECL-3211's. (RSX-11M and VMS for multi-user systems.) It's the latest update of the field-proven PDP-11 operating system.

Keypad Editor. Full-screen-oriented KED Keypad editor that makes full use of DEC terminal functions.

Assemblers/Linkers. MACRO-11-based cross-assemblers and linkers for every chip. Mnemonics identical to original chip manufacturers. Pseudo-ops and directives of MACRO-11. No relearning from chip to chip.

Pascal/C Compilers. Available for most chips, they are true cross-compilers that produce executable code that can be run on the ECL-3211 or the target chip. Permit linking of assembly-level and compiler-level symbols and include utilities for standard load module format conversions.

High-Level Debuggers. Permit user to modify Pascal and "C" variables in the format of the high-level language. User can debug completely within the high-level language without reference to assembly-level parameters.

Advanced Command Syntax. Expanded HELP facility, new memory display and MOVE commands, greatly enhanced command file functions.

Now you can activate command files from breakpoints as well as the keyboard,

include pauses for user response, nest multiple files up to five levels deep. With the new LOG command you can store any sequence of operations for later use.

MORE CHIP SUPPORT.

Emulation, simulation, and full software development support packages for the following chips:

Now shipping

8080	8086	Z80®
8085	68000	6502
8048	6809	6502S
8088	NSC800	

In beta test

80186	68010	9989
8031		

Scheduled for 1984

80188	68008	
68020		

WORLD'S BEST MULTI-USER SYSTEMS.

If you need to coordinate the work of a team of hardware and software engineers, don't forget to check into Emulogic's multi-user systems:

EMUNET™-1. RSX-11M-based system for the PDP-11 family of host computers. Up to 15 users.

EMUNET-2. VMS-based system for the VAX family. Up to 60 users. Easy migration from stand-alone ECL-3211's and from EMUNET-1.

For more information on the ECL-3211 or our multi-user systems, contact EMULOGIC, Inc., Three Technology Way, Norwood, MA 02062, 617-329-1031 or 800-435-5001.

EMUNET is a trademark and Emulogic is a registered trademark of Emulogic, Inc.

LSI-11, MACRO-11, PDP-11, RL02, RSX-11M, RT-11, VAX, and VMS are registered trademarks of Digital Equipment Corporation. Z80 is a registered trademark of Zilog, Inc.



EMULOGIC®
MICROPROCESSOR
DEVELOPMENT SYSTEMS

```

      ***** Stopped @ breakpoint 0 *****
00 32FFFFFF 04 FFFF7FFF 00 FFFFFFFF 04 FFFFFFFF PC 00001000
01 00000000 05 FE700E7C 01 FFFFFFFF 05 FFFFFFFF USP 00000520
02 FFFF7FFF 06 FFFF7FFF 02 FFFFFFFF 06 FFFF7FFF SFP 00000494
03 FFFF7FFF 07 FFFFFFFF 03 FFFFFFFF 07 2710 XMS
User stack +0 2700 +2 3097 +4 0005 +6 0040 +8 0203
System stack +0 2935 +2 FFFF +4 2922 +6 10C0 +8 0100
Supervisor Program
002000 040501050104 SUBT.L 001050104,05
00200C 0004010500C4 ORT.L 0010500C4,04
002012 009500050195 ORT.L 00050105,05
002018 0104 BCLR 00,04
00201A 040501010005 SUBT.L 001010005,05
002020 020004000004 ANDT.L 004000004,00
002026 0104 BCLR 00,04

```

KONTRON
ELECTRONICS

VITEC

Kontron KDS

The Ultra-productive Multifunction Development System

Producing the next wave of smart products isn't enough. You've got to be first! To be first and stay there you need a development system that makes your designers more efficient, a system that speeds up the time-consuming task of developing and integrating hardware and software.

The ultra-productive environment you need is available now in the KDS. Kontron's field-proven CPU, mass storage, slave in-circuit emulation and logic analysis capabilities are perfectly blended in this user-configurable, ergonomically designed workstation. The KDS solution starts with stackable, card-configurable modules that may be located wherever convenient. Add the detached keyboard and adjustable CRT, and a truly productive working environment emerges. You can tilt, swivel, raise or lower the CRT to suit your viewing angle. The detached keyboard gives you control over all systems and the ability to display all functions on the extra-large (15-inch), easy-to-read screen. Two 5¼" floppy disk drives are incorporated in the CPU; an optional 10 Mbyte hard disk plugs in if you need it. Software, emulation and logic analysis are fully integrated.

You have complete control over up to four KSE slave emulators and one KSA logic analyzer. Emulation support is available for most popular 8- and 16-bit chips. You can select the 32-, 48- and 64-channel logic analyzer (to 100 MHz) that suits your needs for timing and state analysis.

KDS comes complete with all the applications software you need. Editors, linkers and assemblers are provided for assembly language programming and for use with Pascal compilers. Software developed on other Kontron systems can be ported to the KDS via an RS-232 link. Industry-standard operating systems* make KDS even more versatile, opening the door to third party software and many new applications. Find out how much more the KDS Multifunction Development System can do for you. Write for a demonstration, or call 1-800-EMULATE.

ADVANCED
ELECTRONIC
INSTRUMENTATION



**KONTRON
ELECTRONICS**

In the United States:
KONTRON ELECTRONICS
630 Price Avenue
Redwood City, CA 94063
TWX: (910) 328-7202; (910) 378-5207
(800) EMULATE; (800) 227-8834

In California:
(213) 641-7200; (415) 361-1012

In Europe:
Kontron Messtechnik GmbH
Breslauer StraÙe 2
8057 Eching West Germany
(0 89) 31901-1
Telex: 05 22 122

*CP/M is a registered trademark of Digital Research, Inc.
*UNIX is a trademarked product of Bell Laboratories.

Circle 113 for Literature
Circle 159 for Demonstration

See our SouthCon Booths 1339 / 1341



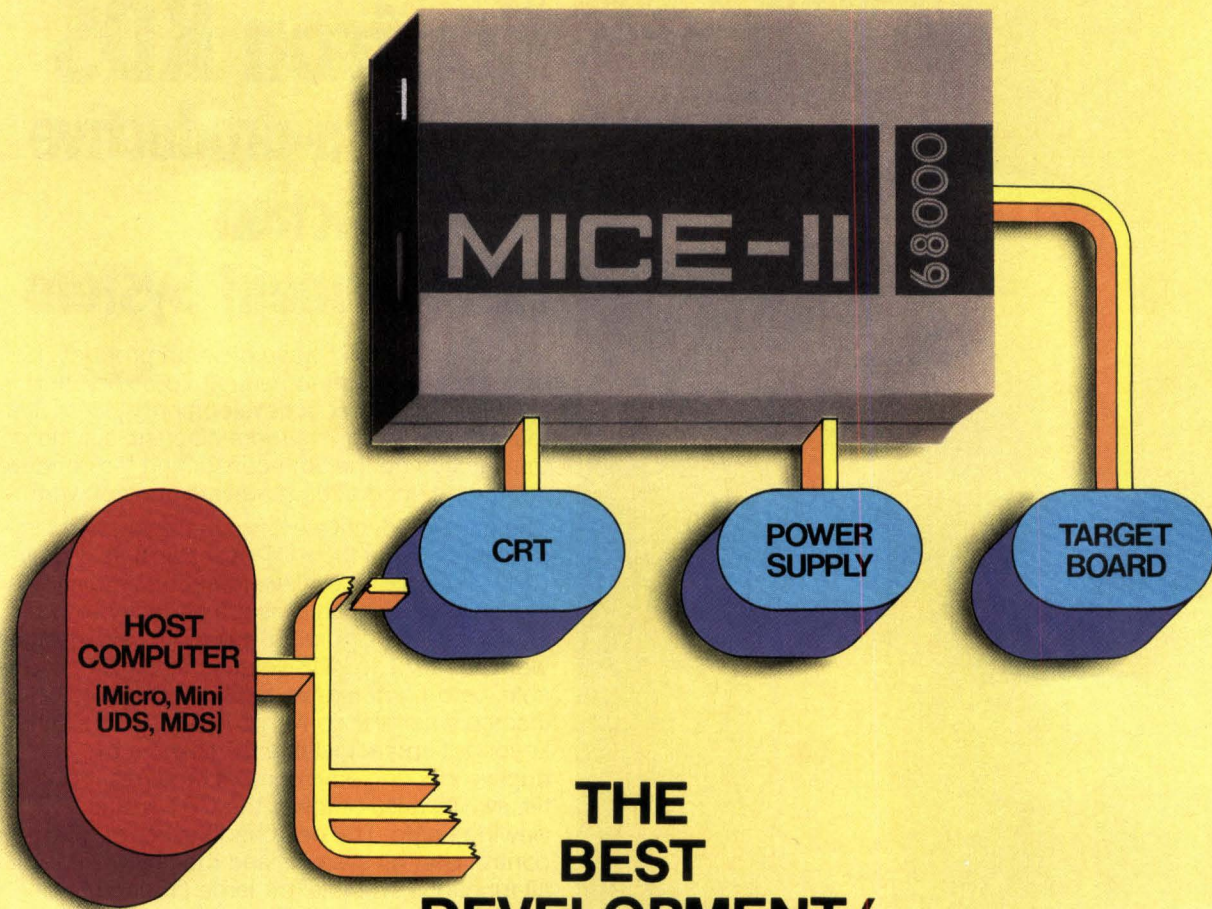

THE BEST DEVELOPMENT/DEBUGGING

TOOL YOU CAN BUY FOR UNDER \$4,000*

It's powerful, portable, configurable. Use it to turn your mini/micro computer into a cost-effective full-scale universal development system.

Use it to expand your full-scale development system into a multi-workstation system.

Use it with MULTI MICE to debug hardware/software in a multi processor environment.

Use it as a portable local debugging tool for field service or production line.

Use it to evaluate different micro-processors at a minimum change-over cost.

It's easy to use. MICE I/O drivers are available for Apple II, IBM-PC, PDP-11, VAX and all CP/M systems.

MICROTEK INTERNATIONAL, INC.
2-1, Science Road 1
Hsinchu Science-based Industrial Park
Hsinchu, Taiwan, 300, R.O.C.

It gives you all these features. Real-time emulation with no wait state • Retain full memory and I/O space • Resident assembler/disassembler • Real-time forward/backward trace up to 2048 cycles • Instruction step, cycle step through program • Two hardware breakpoints • Interchangeable personality module • 32K emulation memory expandable in 32K segments.

And it supports all these micro-processors. MICE I: 8048/49/50 • 8085 • Z-80/R • 6502 • NSC 800 • MICE II: 8085 • 8086/88 (MAX) • 8086/88 (MIN) • 6809/6809E • 68000 • 68008 • Z80R • 6502 • 65SCXX Series • 65SC1XX Series • NSC 800.

MICE does the job. In the lab. In the factory. In the field. Call or write today for full details.

MICROTEK LAB, INC.
17221 South Western Ave.
Gardena, CA 90247
(213) 538-5369

CIRCLE 114

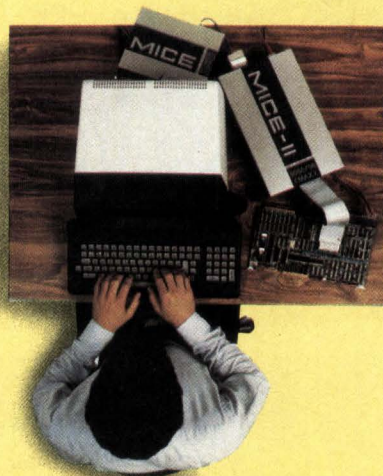

*MICE II only. Price subject to change without notice.

Subset of VAX architecture meets low end of 32-bit market

MicroVAX I expands the VAX product line with a CPU performance that averages 35 percent of the VAX 11/780's. The two-board microcomputer can assume machine and process control applications in industry, as well as single-user and small multi-user computing requirements in business and scientific fields.

Implementing a subset of the VAX architecture, the microcomputer retains all the key family elements. These include virtual memory management with address capability of more than 4 billion bytes, sixteen 32-bit general registers, and 32 hardware and software interrupt priority levels. In addition, all native-mode instructions are provided for byte, word, long-word, quad-word, and single- and double-precision floating point data types. Full memory management performs virtual to physical address translation and page protection. The system supports emulation for the full VBAX instruction set excluding the PDP-11 compatibility mode.

Some instructions that are hardware-assisted in other VAX systems are implemented in software. They include both D and H floating point instructions, decimal strings, some character strings, and compatibility mode instructions. The central processor resides on two quad-height modules occupying adjacent slots in the Q22 backplane. One module contains a 32-bit data path, a microsequencer, and control store. The second module contains both memory management and cache. It also provides the interface logic for the Q-bus connection to the internal VAX architecture. The system uses standard Q-bus memory modules and performs all data transfers in block mode.

Storage options include a 5¼-in., 10-Mbyte RD51 Winchester disk subsystem, and the RX50 dual-floppy diskette drive with a total storage of 800 Kbytes. A 28-Mbyte Winchester disk is also available. The system uses the same compact enclosure as the Micro/PDP-11 computer.

Software packages offer VAX compatibility in development and production environments. VAXELAN software, a compatible subsystem to the VMS operating system, allows application development for realtime control and distributed computing. It consists of development utilities

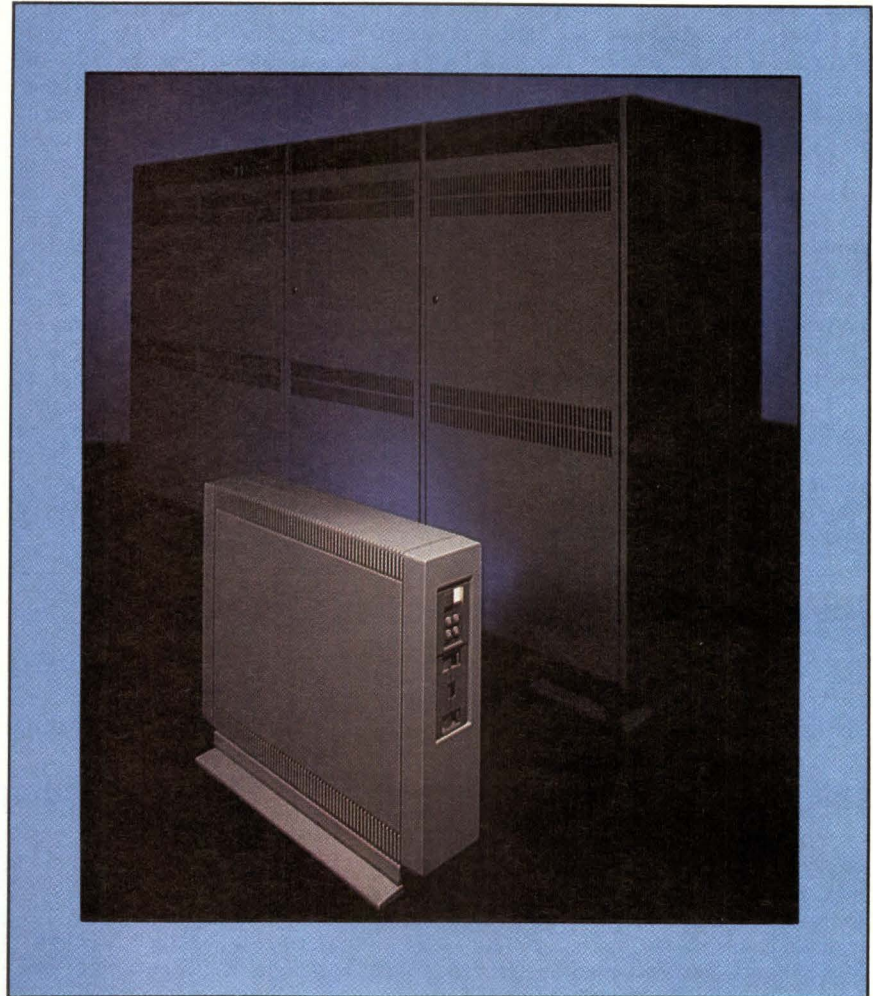

for creating target applications, and a runtime kernel of device drivers and service code that becomes a part of each application. Applications are written in an optimizing native-mode version of Pascal, which can be downline-loaded across network (local or wide area) links, or transferred to target systems by disk or tape. Finished programs are entirely memory resident.

The MicroVMS operating system is a VMS system version for the MicroVAX. Specially packaged, it still provides the same runtime environment as larger VAX computers. In modular form it allows support for configurations with small secondary storage capacity and reduces the overall system cost. A base system provides application execution. One or more system options tailor operations to specific environments, such as net-

working, program development, and multi-user authorization and accounting.

ULTRIX is based on the Berkeley VM Unix system, which takes advantage of the VAX virtual memory architecture. It offers vendor independence and portability. Applications are in nonrealtime design and analysis, and in value-added systems requiring a generic software base.

Supported VAXELAN development licenses begin at \$8200 with a runtime license at \$100. Prices for the MicroVAX I begin at \$9995 for a diskless, rack-mountable unit with 512 Kbytes of memory for dedicated, memory-resident applications. With RX50 diskette and RD51 Winchester disk drives in a floor-standing unit, the price is \$13,880. Initial deliveries are set for Mar 1984. **Digital Equipment Corp.**, 10 Main St, Maynard, MA 01754. **Circle 260**

Two-part array couples memory and logic and adds testing

As a member of the bipolar Macrocell array family, the MCA1500M uses the Macrocell array logic concept and high speed RAM to form an LSI circuit. The logic part of the array uses the MCA2500 macro library (with performance equal to the MCA2500), while the memory part configures 1280 bits in various user selectable modes.

The array consists of 112 logic cells and eight memory blocks. Of the 112 logic cells, 63 are major cells and 49 are output cells. Arranged in a 7 x 9 array, the major cells take up the largest die area. The output cells are along the top and bottom edge of the die. Five output cells double as memory test outputs; they therefore have a restricted options.

Memory portion of the die has eight equal blocks of 32 x 5 bits located on the right one third of the die. This positioning allows convenient routing to and from the logic portion, yet does not disrupt interlogic routing.

The selection of predesigned memory macros customizes memory configuration. These macros store interconnect information for various configurations within a CAD system. Ten basic macros come in any combination within the 1280-bit constraint. In addition, the memory has a dual-port mode design. The six dual-port macros allow the same data to be written into two memory files simultaneously with each file having independent address selection. While in the read mode, an independent address accesses each file.

A memory test circuit is a fixed part of RAM. The testing is the same, independent of user-selected memory configurations. Each block tests as a 32 x 5 RAM with block selection by three higher order memory test addresses. There are some restrictions on option die ports during test access. For example, a test enable input (TE) determines memory mode so that its port is restricted.

Test memory input buffers operate in parallel with the option input ports. An option may or may not use the 15 inputs that are in a fixed location. When the memory is operational, the input buffers disable. Thus they present little influence on option input ports.

Five output cells take in the test outputs from the memory. Fixed to five ports via a CAD system, these cells and ports face restrictions (as outputs) only when used by options. The TE signal selects between memory test and option output on the five ports.

TTL interface provisions allow any device port to assign a TTL compatibility using macro selection at the design stage. TTL-to-ECL translation on input ports and ECL-to-TTL translation on output ports reduces total system package count while enhancing system performance. **National Semiconductor Corp.**, 2900 Semiconductor Dr, Santa Clara, CA 95051. **Circle 261**

Computerized engineering index: a boon to components research

An IBM PC compatible software index that keeps track of some 400,000 products and services from roughly 5000 suppliers is updated every 60 days. By giving design engineers desktop, library-style support without intermediaries, Micro-Index can dramatically reduce the time a staff spends researching prospective system elements.

Product/service descriptions and supplier names in the index reference a companion microfiche data base—Tech-Doc. The data base contains complete specifications, test data, application notes, catalogs, and pricing information for items listed in the index. Source material is reproduced from the supplier's documentation, without editing or abridgement. A detailed contents page outlines key elements in each major database category.

The disk-based index provides company name, address, contact, phone number, telex, and specific page reference to desired document. A search by product description leads to supplier names, addresses, communication numbers, and location of the source

data. Search by supplier name locates addresses, communication numbers, full product line description, and location of the firm's complete data on microfiche.

Structured around an engineering "thesaurus," the index addresses entries by either formal nomenclature or common descriptions. Spelling algorithms branch to a new menu for each "correct" item selected. A partial product description or company name will call up a menu of related records.

Eighteen product/service categories constitute the index and data base. These include electrical and electronic components, computers, communications, and instruments and controls. Indexing software comes on 5¼-in. double-sided, double-density floppies or a 10-Mbyte hard disk, and runs on 256-Kbit microcomputers using the MS-DOS version 2.0 operating system. Future releases will port Micro-Index to the



CP/M operating system and Digital Equipment Corp minicomputers and mainframes.

Apart from the indexing software and microcomputer, a complete workstation includes microfiche cards and reader. Annual database subscription for any one component category ranges from \$105 to \$945; a partial component index costs 57 percent of the component order. Total component index is \$2850. **Inacom International**, 4380 S Syracuse St, Denver, CO 80237. **Circle 262**

Workstation integrates test and measurement with CAE

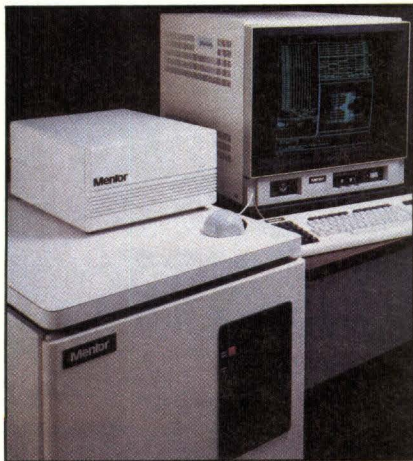

With a complete logic analysis system and tools from the Idea 1000, the Midas 7000 supports the entire digital hardware design cycle. The system covers not only schematic capture, simulation, and physical layout, but also verification and test of the final hardware.

Data acquisition and clock probes connect the 7000 to the hardware under test.

Realtime acquisition results go to the workstation's main memory. Once there, a disk drive on the network stores the data, or the workstation can process it.

To analyze software performance, a user-written program (anywhere on the network) acquires and processes real-time software execution. In histogram form, the CRT displays subroutine call frequencies that are automatically sorted. Through the use of command macro files and programmable keys, only a single keystroke will accomplish the software analysis.

A triggering system is the basis for state acquisition. Its 60-word recognizers trace software data flow. The recognizers organize into 15 states for either triggering or data qualification. A programmed trigger sequence can jump between states, branch to other states, or branch within a state to trace recursive software flow.

The sample clock uses five clock lines defined in terms of logic or transition edge, then they are ORED together for synthesis of bus-cycle clocks for micro-

computer systems. Two hold clocks demultiplex buses without double probing.

To make the most of its 4-Kbyte/channel data storage memory, the timing analyzer uses several acquisition modes to increase the time window for acquiring data. The transition mode stores data only when a transition occurs on one of the acquisition channels. A counter provides realtime representation of timing activity on the display. The counter keeps track of the number of samples between transitions.

A multitrigger mode breaks data acquisition up into subgroups of 16 samples. The same user-specified trigger event is at the center of each subgroup. During acquisition, an additional subgroup is stored for each trigger event. In this way, up to 32 stored subgroups can give the user a record of triggering occurrences.

Available in the first quarter of 1984, the Midas 7000 is priced at \$14,900. **Mentor Graphics Corp.**, 10200 SW Nimbus Ave, Portland, OR 97223. **Circle 263**

Development system turns any microcomputer into workstation

Using a personal computer as its control console, the Universal Development Laboratory integrates an analyzer, an emulator, a programmer, and an input stimulus generator in a single pod-sized box. A control program running on the host coordinates system resources. When emulating a target ROM, the laboratory becomes a development system for any target processor.

The 48-channel bus state analyzer triggers if a program goes outside its normal address range. In addition, the trace buffer stores 170 bus cycles that can be used for debugging. Trigger setups and traces of good systems can be saved on disk, then automatically compared to later test traces. A filtered trace allows only writes to a particular memory location together with a following cycle (which contains the next instruction). Four-step sequential triggering specifies up to three events that must occur before triggering becomes possible.

To search for the trigger, the system uses high speed RAM truth-tables instead of comparator circuits. This allows any

8-bit function to be specified on each of the 6 input bytes.

Universal at both ends, the system interfaces to the host through an RS-232 port and to the target system through a standard ROM socket. Because the bus state analyzer can debug any processor, target processor emulation is unnecessary. Most target bus signals connect at the ROM socket, so a complete view of bus operation takes only about 12 additional analyzer inputs. The signals connect by plugging probe wires into a 40-pin DIP clip on the target processor.

Since the target processor stays in its socket, operation is transparent. Moreover, maximum 195-ns access time makes ROM emulation fast enough for full-speed operation with next generation processors. A single wire connects both the analyzer and the emulator to target system signals, minimizing loading.

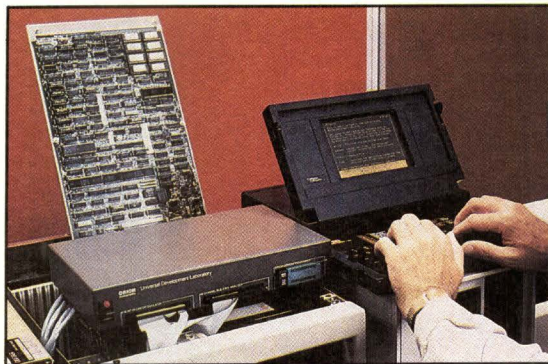

The ROM emulator and EPROM programmer share the same memory, so EPROMs can be burned directly from the target program image used for emulation. This target program can be loaded several ways: read from hexadecimal or binary disk files, received serially in hexadecimal format, or from a ROM in the programming socket.

The system sells for \$2395 with 64 Kbits of emulation memory. **Orion Instruments**, 172 Otis Ave, Woodside, CA 94062. **Circle 264**

SYSTEM COMPONENTS

Ergonomic VDT's calling cards are programmable features and low cost

The Freedom 200 offers a long list of features in one package. Consisting of a 12-in. display and a detachable keyboard, the terminal's points of interest range from a nonglare screen to setup modes and programmable functions keys.

The CRT uses a 24 x 80 display format. The 25th line is user accessible for status or other information. A full tilt (+15-degrees, -5-degrees) and swivel (70-degrees) console houses the etched green phosphor screen.

In native mode, display memory is one page with the second page optional. In emulation mode, memory reaches two pages with additional pages optional. The unit emulates both TeleVideo 950 and Lear Siegler ADM 31 terminals.

Advanced video features include non-embedded character attributes. In visual mode these are normal, reverse, half intensity, underline, blink, and blank. In data entry mode they include protected, alphanumeric, alpha only, numeric only, and extended numeric.

Jump or smooth scroll is available. Smooth scroll is programmable with rates of 2.5, 5, and 10 lines/s. The user can elect to scroll only parts of the screen by defining a scrolling region.

Four communication modes are provided: block, conversation, monitor, and local. Block can be immediate or deferred and sent from command. Conversation mode transmits half and full duplex. Monitor mode displays control codes in programming applications, while local mode operates standalone.

The detached, low profile keyboard clusters 106 sculptured keys into functional groups. Twenty programmable function keys (using the shift) produce up to 256 Kbytes of code sequences. These keys can also send 20 preprogrammed default sequences. The 11 cursor control keys assume an inverted "T" format. In addition, there are nine editing keys and 12 functional command keys.

Handshaking protocol is x-on/x-off with programmable characters and DTR. Fifteen transmission rate selections range from 50 to 19.2k baud. Parity choices are even, odd, or none, with



word structure at 7 or 8 data bits with 1 or 2 stop bits. Interface is via EIA RS-232-C.

The terminal is priced at \$745 for quantities of one to nine; \$670 for 25 to 99 units. **Liberty Electronics**, 625 Third St, San Francisco, CA 94107. **Circle 265**

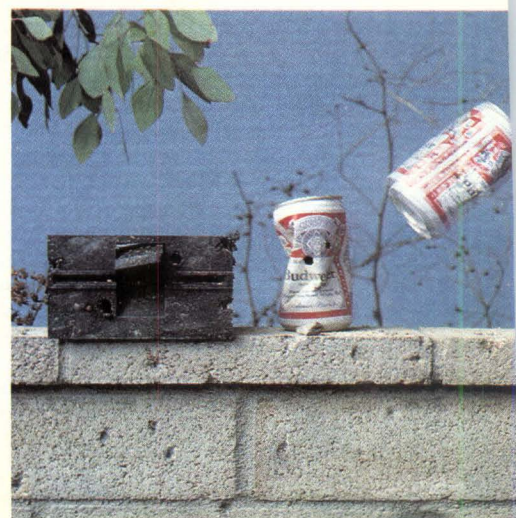
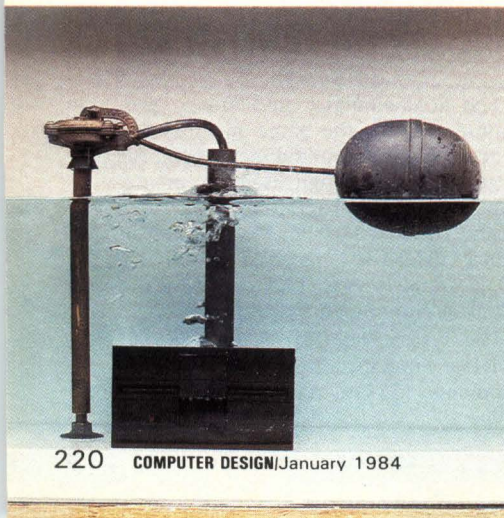
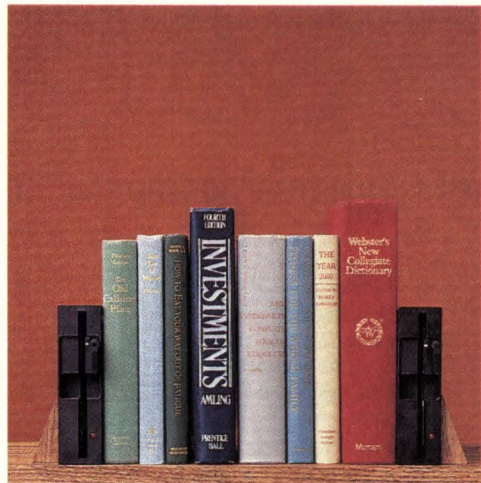

Small size industrial computer

Indy is a portable computer designed for a rugged multitasking environment. It emphasizes software flexibility by offering CP/M-86 and RMX-86 operating systems; Fortran, Pascal, Basic, and C compilers; and various utility programs. Based on a Multibus architecture, the computer consists of 16-bit 80186, 512 Kbytes of parity RAM, 9-in. CRT, dual 3.5-in. floppy drives, and parallel serial ports. Basic computer configuration containing only the CRT controller board costs \$1975. **Monolithic Systems Corp.**, 84 Inverness Circle East, Englewood, CO 80112. **Circle 266**

Supermicro computer family

Decentralized hardware and software are features of the Multex I and II. Hardware includes dedicated processor buses and multi-ported processors that share a common system bus to provide 6.3 Mbytes of RAM for up to 32 users. Running on software with a standard Unix programmer interface and built-in DBMS, the processor performs many

operations without application software. The Multex I has a 157-Mbyte Winchester, while the Multex II combines a 315-Mbyte disk with a 16-channel 1200-baud full-duplex modem. This provides a total network capacity of 1024 users. The two systems are priced from \$25,000. **NuVec Laboratories, Inc.**, 429 Marrett Rd, Lexington, MA 02173. **Circle 267**

Mini-compatible color workstation

The 4180 is a color raster addition to general purpose minis. The workstation's 19-in. monitor displays 16 colors with 1024 x 1024 resolution. A 20-MHz (50-ns) pixel writing rate generates image updates. It offers both 2-D and 3-D local processing and display/communication speeds of 3.088 Mbaud at a distance of 1.5 miles. In a typical configuration, the per-workstation price is less than \$43,000. **Adage, Inc.**, 1 Fortune Dr, Billerica, MA 01821. **Circle 268**

Portable with fixed disk



With 16 bits and a 10-Mbyte fixed drive, the Compaq Plus is capable of running all software developed for the IBM PC XT. The unit contains 128 Kbytes of RAM, a 9-in. video display, two PC-compatible hardware expansion slots, MS-DOS 2.0, and Basic. The portable uses a shock isolation system to protect the fixed disk and ensure its reliability. Price is \$4995. **Compaq Computer Corp.**, 20333FM 149, Houston, TX 77070. **Circle 269**

Six things you can do with your obsolete floppies.

Floppies were fine in their day. But they just don't make sense with the professional desktop computers of today.

What's the answer? The DMA 360 removable 5¼" Winchester. It's exactly the same size as a 5¼" half-height floppy drive — but that's where the similarity stops.

The DMA 360 gives you hard-disk reliability. Floppies don't.

The DMA 360 protects your data in a totally sealed cartridge. Floppies don't.

The DMA 360 packs 10 megabytes on a single ANSI-standard cartridge. Floppies don't. It takes up to 33 floppy disks to achieve an equal capacity.

The DMA 360 even has a lower cost-per-megabyte than a floppy. But it gives you so much more.

Like an average access time of 98 milliseconds. A transfer rate of 625 kilobytes per second. And an error rate that's on par with the most reliable conventional Winchester disk drives.

There's no way you'd get that kind of performance from a floppy!

In fact, anything you can do with a floppy, you can do even better with a DMA 360. That's

why we call it the floppy replacement.

For more information on what you can do with your obsolete floppies, write DMA Systems, 601 Pine Avenue, Goleta, CA 93117. Or call us at (805) 683-3811, Telex 658341.

Introducing the floppy replacement: DMA Systems' new half-height removable 5¼" Winchester.



DMA
SYSTEMS

The Removable Winchester Company.

Micro with built-in hard disk

The TRS-80 256-Kbyte micro comes with a self-contained 1.25-Mbyte 8-in. floppy drive and a 15-Mbyte hard disk drive. It accesses 15 million characters on hard disk, and interfaces to an additional 12-Mbyte drive for about 9000 pages of storage. The computer comes with the

TRS-Xenix multi-user operating system, which allows up to three users simultaneously without loss of performance. The dual-processor design features Z80A and 68000 16/32-bit micros for high operating speeds. It is available for \$6999. **Tandy Corp/Radio Shack**, 1800 One Tandy Ctr, Fort Worth, TX 76102. **Circle 270**

Array processor memory options

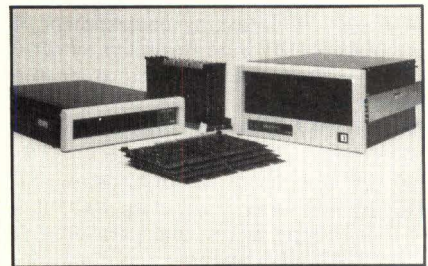

Consisting of a 375-ns, 256-Kbyte memory board, Mini-MAP 211 complements the existing 111 series. For both series, a 375-ns, 1-Mbyte board is available. Designed to meet the needs of large directly addressable memory, tight packaging, and economical pricing, the options target applications including medical imaging, CAD/CAM, and simulation. Burdensome algorithms can be offloaded from the host to the array processor, which can perform floating point calculations one or two times faster than minis or superminis. The 1-Mbyte memory option costs \$4160 in quantity 50, while the 211 processor is \$13,175 quantity 50. **CSP Inc**, 40 Linnell Circle, Billerica, MA 01821. **Circle 271**

Step up to a new standard in disk drive performance 12 megabyte/sec transfer rate

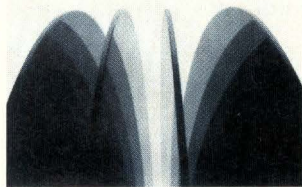

Now, you can have data transfer rates in a large-scale disk storage system unequalled in today's OEM disk drive market. This is a real-world solution for designers of graphics, image and other high performance data processing systems. It improves your system's performance while giving your customers the large-scale data storage, higher data transfer rates and added system throughput demanded by today's applications. IBIS provides 1.4 gigabytes of data storage on a single 14-inch Winchester disk drive. The data transfer rate is 12 megabytes per second with average access time of 16 milliseconds thus giving you the fastest disk drive in the industry. Plus, the "designed-in" reliability assures your system's performance.

Utilizing the latest technology in thin film plated media and advanced air filtration, our disk drives also feature self-diagnostics, dynamic error detection, and modular construction that promotes ease of servicing.

Step up to a new standard in disk drive performance, contact IBIS Systems, Inc., 5775 Lindero Canyon Road, Westlake Village, CA 91362. Telephone (213) 706-2505.



Supermicro systems

System 286/310 and 286/380 combine iAPX 286 micro and 80287 numeric coprocessor with an enhanced Multibus architecture and system software. The basic package includes chassis, power supply, disk storage, single-board computer, operating system software, and languages. Operating system is available for real-time applications and is object-code compatible with iRMX 86. The Xenix 286 is also available. Prices range from \$9900 to \$29,860. **Intel Corp**, 5200 NE Elam Young Pkwy, Hillsboro, OR 97123. **Circle 272**

Computer compatible with IBM PC

The 16-bit TS 1605 comes with 128 Kbytes of memory standard, with optional expansion to 256 Kbytes. Based on the 8088, it offers high resolution (640- x 200-pixel) graphics on a 14-in. green phosphor display. The computer has two half-height 5¼-in. floppy drives, each providing 368.6 Kbytes of formatted storage. Ports include one RS-232 async serial port and one IBM-like DB-25S parallel printer port. **TeleVideo Systems Inc**, 1170 Morse Ave, Sunnyvale, CA 94086.

Circle 273

Removable Winchester drive

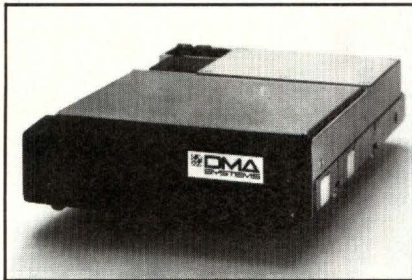

A half-high, 5 1/4-in. drive features 98-ms access time and improved transfer rates over floppy disk drives. Extensive air filtration and a 30-s purge cycle ensure safe operation. Fully retracted heads load dynamically to avoid head and media damage. Moreover, onboard firmware lets the user format a blank cartridge after it is inserted into the drive. This eliminates the need to write servo data on the disk surface. The DMA 360 is priced at \$500 in quantity. **DMA Systems Corp.**, 601 Pine Ave, Goleta, CA 93117.

Circle 274

Battery-backed RAM

The 1822CMOS RAM board features 128 Kbytes of storage on one half-quad size board. Organized to support 32-, 64-, 96-, and 128-Kbyte RAMs, it uses a 2-K x 8 chip for the 32-Kbyte board and a 8-K x 8 chip for the other models. Self-charging NiCad batteries provide data retention for one month. The board supports 16-, 18-, and 22-bit addressing with up to 2 Kwords from the 4-Kbyte I/O for additional space. Applications include non-volatile program store, data logging, and auto-restart after power failure. **Adac Corp.**, 70 Tower Office Pk, Woburn, MA 01801.

Circle 275

Slimline 8-in. floppy drive

With an unformatted storage capacity of 9.6 Mbytes, the FDD-441 uses a 5 1/4-in. disk controller compatible interface. The drive has a data transfer rate of 1.5 Mbit/s and an average access time of 168 ms, with a track-to-track access time of 3 ms. Track density is 96 tracks/in. It employs a micro-controlled stepper motor, capable of accurately positioning the magnetic head. Rotational speed is 360 rpm, latency is 83 ms, and data transfer encoding method is modified frequency modulation. **Hitachi America, Ltd.**, 1800 Bering Dr, San Jose, CA 95112.

Circle 276

Dynamic parity Versabus RAM

The PSM 1VP offers 1 Mbyte on a single board. It features a 32-bit structure and a choice of 512 and 256 Kbyte versions. By meeting full requirements of the Versabus spec, these memories support data transfers of byte, word, and long-word width for future compatibility. The RAM provides error status reporting, user-definable mode response, fast access time, and single-bit error detection. A bus parity function ensures high immunity from system failures. **Plessey Microsystems, Inc.**, 451 Hungerford Dr, Rockville, MD 20850.

Circle 277

Disk drive subsystem

The 5360 series provides 406 Mbytes of user accessible storage (formatted). It features 1.9-Mbyte/s data transfer and an average seek time of 18 ms. Physically, the drive consists of a single spindle drive motor, power supply, operational electronics, front panel, and sealed module containing the spindle media, rotary actuator, and read/write heads. The 10.5-in. fixed media consists of six platters with one servo and ten data recording surfaces. Drives cost \$19,000 per unit. **Harris Corp., Computer Systems Div.**, 2101 W Cypress Creek Rd, Fort Lauderdale, FL 33309.

Circle 278

Winchester drive at 100 Mbytes

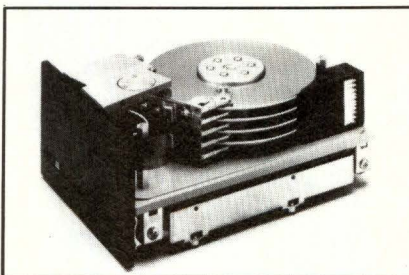

Using thin-film media exclusively, the v2100 offers a 25-ms average access time. The 5 1/4-in. drive meets the ST412HP interface standard with a 10-Mbit data transfer rate. Features include a dual-frequency, closed-loop servo system that allows continuous sampling and correction of head-to-track positioning as disks rotate. Track density is 960 tracks/in. An automatic actuator lock and dedicated landing zone counter potential shock and vibration damage. **Vertex Peripherals, Inc.**, 2148 Bering Dr, San Jose, CA 95131.

Circle 279

**PACKAGED
POWER** 

FCC & VDE

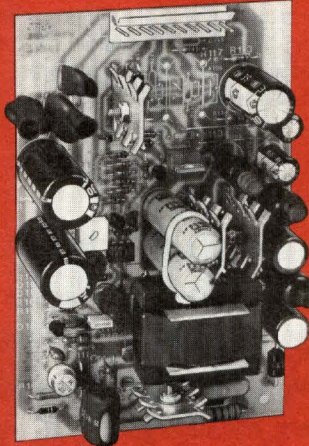

SWITCHERS

- Custom or Standard
- Eval. Samples 2-3 Weeks
- 25 to 400 Watts
- 90,000 Hour MTBF
- Demonstrated
- Multiple Outputs
- UL, CSA, FCC, VDE, IEC
- FCC Level B w/o Cover

We ship thousands of switching power supplies each week to major manufacturers of computer equipment. Fast response to custom requirements have made Compower the fastest growing manufacturer of switchers in the industry.

Call Compower today for price and delivery on your requirement.

See GOLDBOOK or EEM for standard products.

Compower

2220 LUNDY AVENUE • SAN JOSE • CA 95131
(408) 942-1600 • TELEX: 172760

COMPUTER
PRODUCTS,
INC.
Companies

**Power
Products
Group**

CIRCLE 117

Static CMOS RAM card

The CBC 512/24 features three-year minimum data retention, 8- or 16-bit CPU compatibility, 24 address lines, Multibus interface, and 800-mW typical operating power. There are three options for battery backup: onboard rechargeable NiCad battery, nonrechargeable lithium battery, or external

battery. The starting address is selectable on 64-Kbyte boundaries in a 16-Mbyte memory space. Access time is 300 ns and memory cycles range from 470 to 570 ns for read and from 475 to 575 ns for write. Prices are \$1989 to \$3978. **Diversified Technology, Inc**, PO Box 748, Ridgeland, MS 39157. **Circle 280**

SEATTLE GIVES YOU AN EDGE IN S-100 SYSTEM DESIGNS

You can unlock new system capabilities with high-performance S-100 boards from Seattle Computer. All are IEEE-696 compatible. But, for innovative systems that demand performance beyond the limits of conventional S-100 boards, you'll want to know more about these Seattle Computer products. For example, with our 8 MHz 8086 CPU, you'll be able to build systems that run faster and consume less power than before. Take a closer look:

8086 CPU Set: 8 MHz 8086 CPU • CPU Support board includes a console serial port, a second serial port, Centronics parallel port, vectored interrupt controller, four 16-bit timers and EPROM monitor for 8086 • MS-DOS 2.0 plus development utilities • 8087 numeric coprocessor is optional
• Single Qty: \$595.00

64k Static RAM Fully static design makes interfacing easy • Compatible with a variety of CPU and DMA devices • High-speed (85 ns) RAMs operate to 10 MHz with no wait states • 16k, 32k, and 48k OEM versions are available
• Single Qty: \$495.00 (64k)

Disk Master™ Controls as many as four 8" and four 5.25" floppy disk drives simultaneously, in any combination • Uses 1793 disk controller chip • Can be used with 10 MHz CPUs • **Single Qty: \$325.00**

Multi-Port Serial Card 2- and 4-port versions are available • These RS-232 ports operate as either "data sets" or "data terminals" • 36" cables included
• Single Qty: \$280.00 (4-port)
\$210.00 (2-port)

For the whole story on high-performance Seattle Computer S-100 boards, call:

1-800-426-8936

Dealer and OEM inquiries are invited.

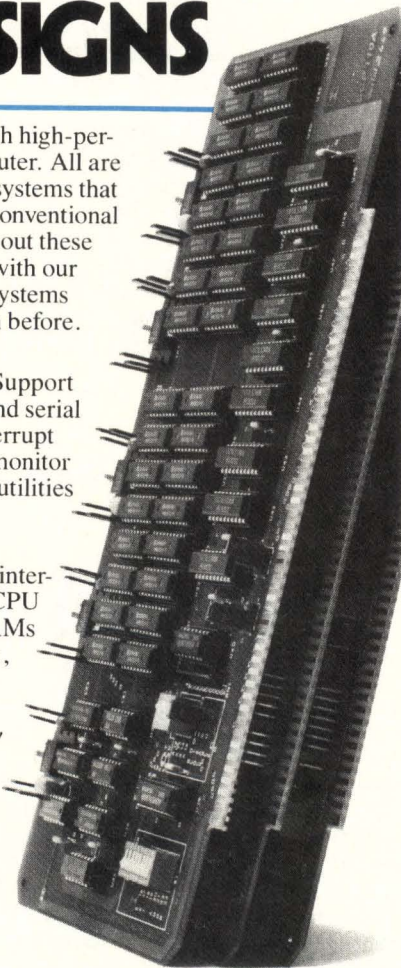

SEATTLE COMPUTER
 1114 Industry Drive
 Seattle, WA 98188

Half-wide streamer



The MT-1220 has a 330-Mbyte capacity and uses the industry standard Pertec micro formatter interface. The drive employs a 24-track, bit-serial, serpentine format with a packing density of 9600 bits/in. It operates in 200- or 50-in./s streaming mode or a 50-in./s start-stop mode. Data is encoded into a 4/5 GCR format, with all encoding and decoding done by the integral formatter. A unique head-stepping feature permits access to any record stored in the cartridge within an average of 30 s. Drives are \$4950 each and data cartridges are \$100 each. **MegaTape Corp**, 1041 Hamilton Rd, PO Box 317, Duarte, CA 91010. **Circle 281**

Cartridge drive with 600 Kbytes

This flexible 3-in. drive is compatible with standard 5 1/4-in. drives. The MFD-80 records double-density, double-sided on the standard 3-in. disk cartridge at 100 tracks/in. It permits the use of all 48 tracks on each side of the disk. The basic unit is 3.54 in. (90 mm) by 1.58 in. (40 mm), including electronics. A cam controls the read/write head carriage assembly for improved reliability. The drive's rotation speed is 300 rpm and transfer rates are 250 kbits/s. Average track-to-track access time is 10 ms. MTBF is estimated at 8,000 h. **Janome, Ltd**, 1-1 Kyobashi 3-Chome, Chuo-Ku, Tokyo, Japan. **Circle 282**

Let's hear from you
We welcome your comments about this issue. Just jot them on the Reader Inquiry Card.

The New WY1000 Microcomputer

BUILDING BLOCKS

Powerful, Affordable, Expandable.

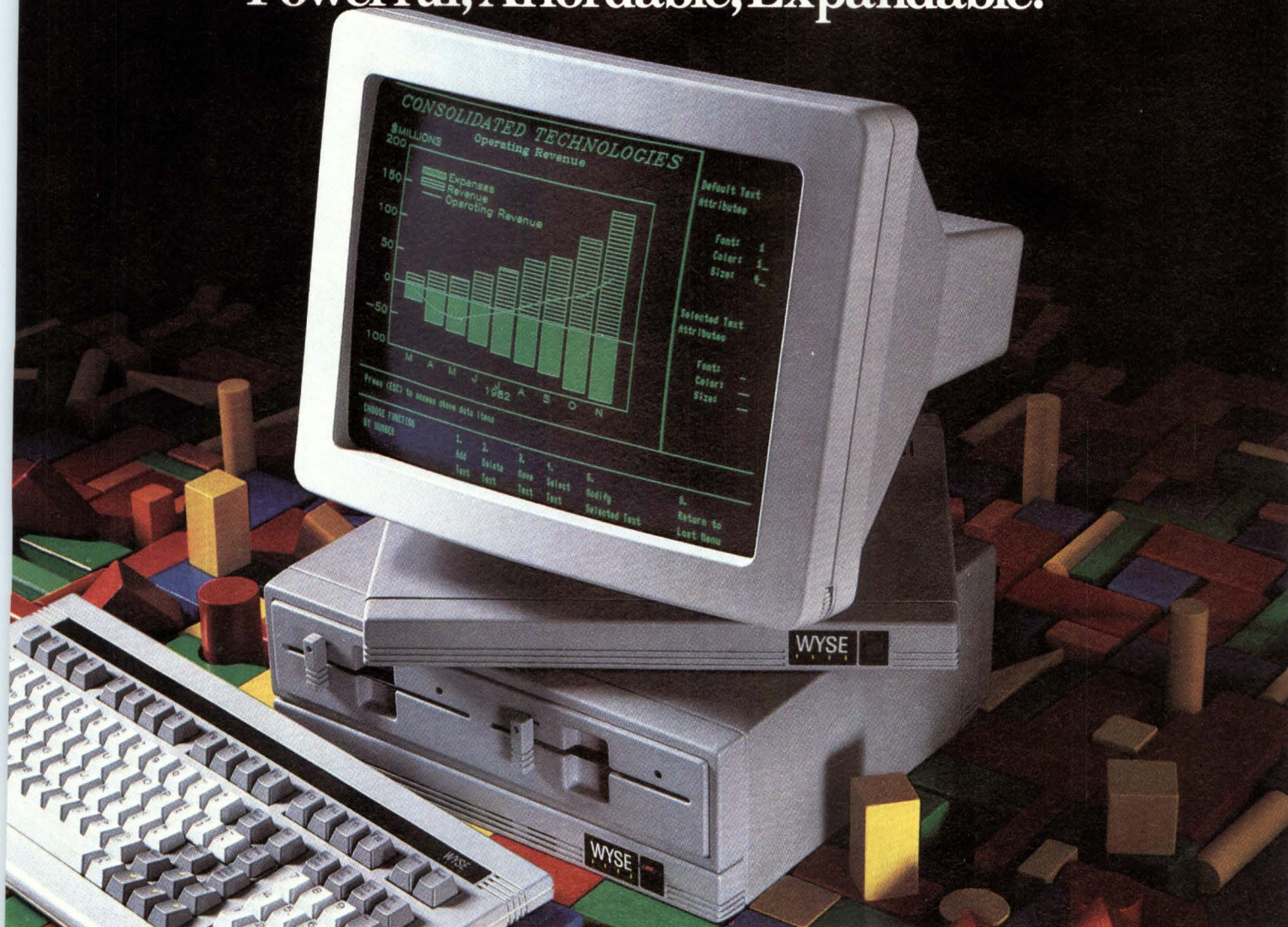

The WY1000 stacks up to be a lot of machine from a few simple pieces. By adding the WY1000 microcomputer to the good-looking, ergonomic WY50 display terminal, we created the most exciting concept in desktop workstations on the market today.

We also added sophisticated high resolution graphics, suitable for the most demanding applications.

Plus, we added color capability, when used with our color terminal.

And on top of that, we added a Winchester Disk Drive option providing an additional 10 megabytes of storage.

FEATURES:

- 80186 16 Bit 8 MHz Processor
- 128KB to 768KB RAM Memory
- Two Floppy Disk Drives (725 KB)
- Optional 10 MB Winchester Drive
- RS232 & RS422 Serial Ports
- Optional Graphics/Color Graphics
- Networking Capability
- CP/M™, MS-DOS™ Compatible
- Priced from only \$1995

CIRCLE 139

Best of all, we priced the WY1000 from only \$1995. It all adds up to a system builder's dream.

For a complete brochure on the WY1000 contact Wyse Technology toll free at 800/421-1058.

WYSE

Make the Wyse Decision.

WYSE TECHNOLOGY 3040 N. First St., San Jose, CA 95134, 408/946-3075, TLX 910-338-2251, Outside CA call toll-free, 800/421-1058, in So. CA 213/340-2013.

A CRASH COURSE IN DISK AND DRIVE TESTING:

Disk Testing

ADE RVA instruments will show you how to test excessive acceleration, flatness, radial waviness, datum positioning, axial run-out and thickness.

Spindle Testing

Learn the nuances of testing axial and radial runouts, bearing quality, axial/radial acceleration, non-repetitive runout, radial resonance, wobble, and high frequency vibration.

Head/Assembly Testing

ADE RVA instruments give you advanced instruction on head positioning accuracy, head motion studies, dynamic flight characteristics, pitching and rolling.

ADE RVA instruments maintain quality control from design through production. Only ADE systems can measure dynamic displacements from tenths of microinches to thousandths of an inch from 0 to 50 KHz frequency response. Sign up for the ADE course (every major manufacturer of disks and drives already has).

ADE Corporation

77 Rowe Street
Newton, MA 02166
Telephone: (617) 969-0600
Telex: 922415

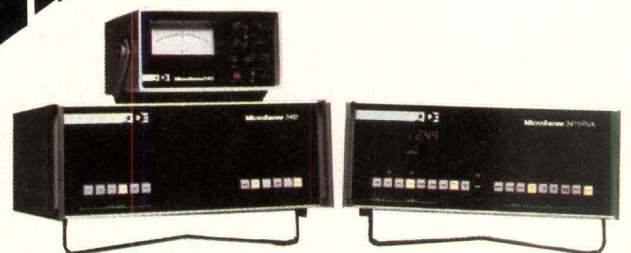

Tri-density tape transport

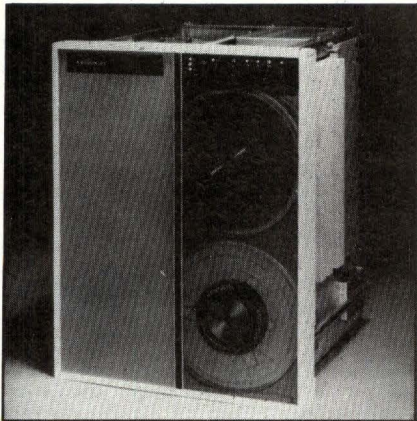

Model 940 uses nine-track, group-code-recording and provides high speed backup for minicomputer systems. It has a 6250-bit/in. data density for an unformatted capacity of 180 Mbytes on a 10.5-in. reel. The unit will also operate at 1600 bits/in. using phase encoding and at 800 bits/in. using nonreturn to zero encoding. Diagnostics allow onsite troubleshooting in the field or remote diagnostics via a modem. A bipolar bit-slice processor handles digital write functions. In 1000s, the price is \$7500 each. **Kennedy Co**, 1600 Shamrock Ave, Monrovia, CA 91016. **Circle 283**

Add-in memory board for VAX

The MK8076 is a direct replacement for the DEC M8750 memory board and features a 1-Mbyte storage capacity. It uses 64-Kbyte dynamic RAMs (5-V only) that are upgradable with 256-Kbyte DRAMs. Other features include a data transfer rate of 39 bits (32 data and 7 ECC), an on/off-line switch, and three LEDs. The board also supports battery backup operation. Single quantity price is \$2450. **Mostek Corp, sub of United Technologies Corp**, 1215 W Crosby Rd, Carrollton, TX 75006. **Circle 284**

Disk cache PC system

Containing RAM that ranges from 128 Kbytes to 1 Mbytes, Quick Disk is an external add-on memory device. It operates 120 times faster than a Winchester and 190 times faster than a floppy when performing common data transfers. It also features dynamic error correction and can be used independently as an additional data storage unit or in combination with a floppy or Winchester as a disk cache. Five models are available that range in price from \$2795 (128-Kbyte version) to \$8585 (1-Mbyte version). **Santa Clara Systems**, 1860 Hartog Dr, San Jose, CA 95131. **Circle 285**

Half-high 5¼-in. Winchester

The 12-Mbyte ST212 drive improves shock protection with low mass mini-slider ferrite R/W heads. It is fully compatible with the standard-height counterpart. Average access time is 65 ms. Track densities are 550 tracks/in. The drive has a total of 612 tracks per surface, divided into two 306-cylinder bands. It is configured with one oxide-coated disk and four R/W heads (two per surface), each of which addresses 306 cylinders. Price is \$690 in lots of 1000. **Seagate Technology**, 920 Disc Dr, Scotts Valley, CA 95066.

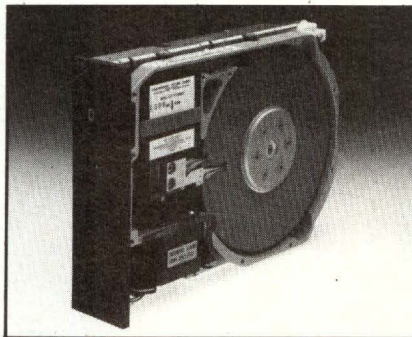

Circle 286

Optical storage subsystem

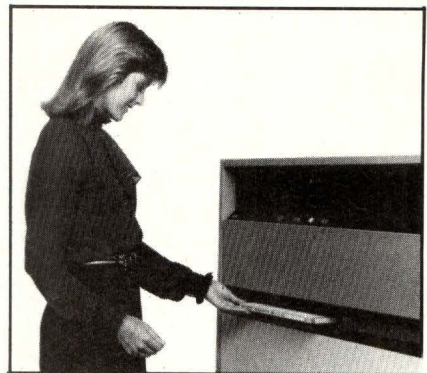

The 7600 is particularly suited for applications requiring large amounts of accessible data. It stores 4 Gbytes of data on the surface of a single optical platter. Data transfer rate between host computer and storage unit is 3 Mbytes/s. The subsystem consists of optical storage unit, media unit, storage control unit, and optical storage access software. It is compatible with IBM 370, 4300, 30XX, and others running under MVS/SP 1.3. **Storage Technology Corp**, 2270 S 88th St, Louisville, CO 80028.

Circle 287

MORE STORAGE FOR LESS

DEC
USERS

LSI-11
COMPATIBLE

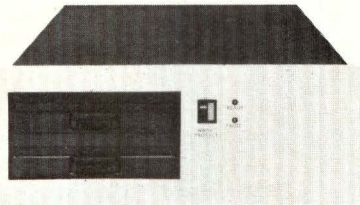

EMULATION RK06/RK07

42MB Winchester/Floppy (8") ... \$6995.00
70MB Winchester/Floppy (8") ... \$7495.00
140MB Winchester/Floppy (8") ... \$9995.00

EMULATION RL02

10MB Winchester/Floppy (8") ... \$4495.00
20MB Version Add ... \$ 500.00

ALL SYSTEMS CONTAIN 2MB OF FLOPPY BACKUP

★ NEW ★ MORE MEMORY ON A SINGLE CARD THEN ANY OTHER MANUFACTURER ★ NEW ★
512KB TO 2MB QBUS ERROR DETECTING AND CORRECTING MEMORY

CALL FOR MORE DETAILS!

"OFFERING QUALITY WITH AFFORDABLE PRICING"



Chrislin Industries, Inc.

31352 Via Colinas • Westlake Village, CA 91362 • 213-991-2254
TWX 910-494-1253 (CHRISLIN WKVG)

RK06, RK07, RL02, QBUS, DEC, LSI-11 are trademarks of Digital Equipment Corporation.

Our UNIX Micro GE's Industrial

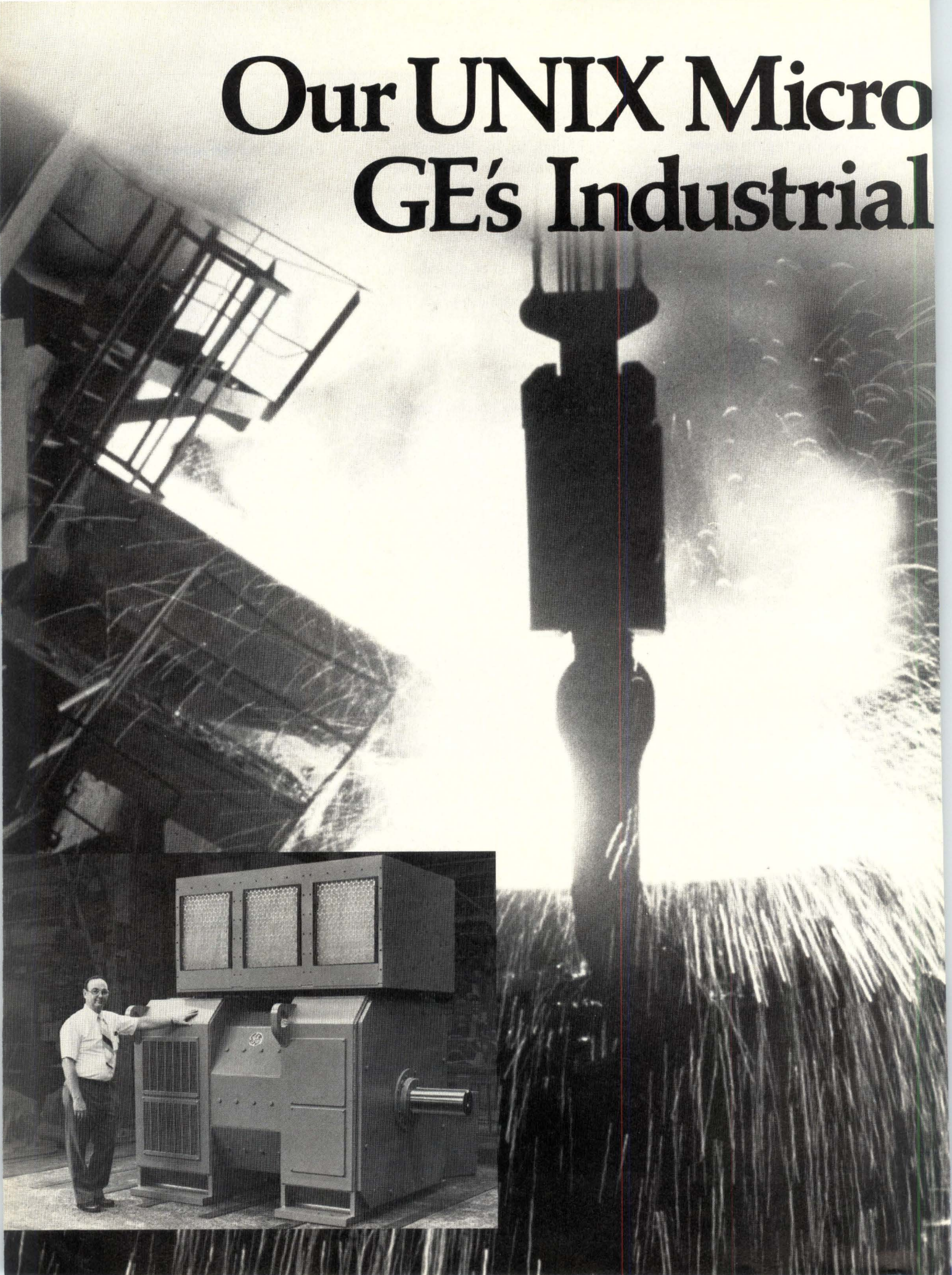
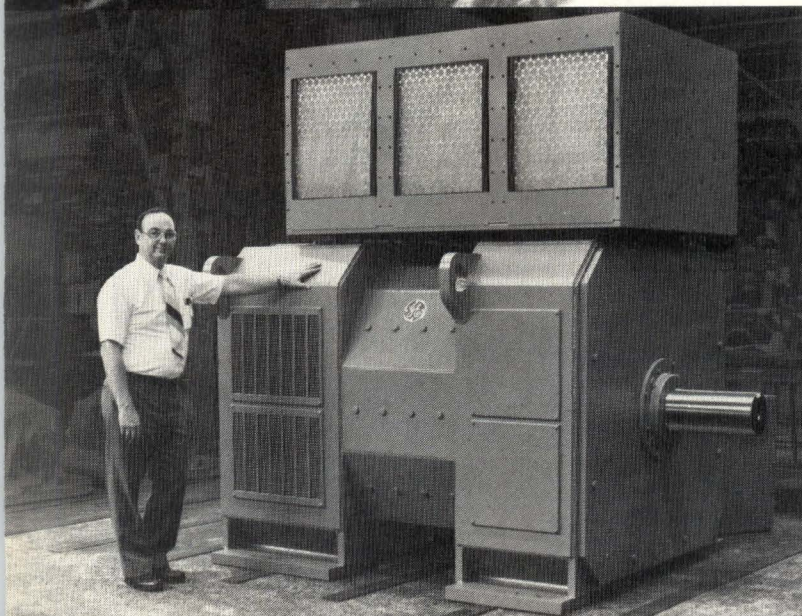

Systems Fine-Tune DC Motors.

We're Dual Systems.

And when the people at GE needed a microsystem as an engineering design tool for industrial DC motor applications, they turned to us.

After all, our high speed microsystems have performed in the clutch for Boeing and Sony and Ford and United Press International, just to name a few.

And for three years we've been delivering 68000-based systems, full UNIX* Version 7 with Berkeley enhancements, and IEEE-696/S-100 bus conformance. That's longer than anyone else.

Which brings us to our newest high-performance micro, the 83/80. Featuring the full UNIX capabilities of Version 7 or System III, the 83/80 can handle up to twelve users and provides a standard 512 KB of dynamic RAM with parity that's expandable to 3.25 MB.

And we've backed it with a full one-year warranty.

Our 83/80 incorporates a high-throughput SMD controller and an 80 megabyte Winchester disk drive with 20-25 milliseconds average seek time. And our backup memory is well worth remembering — it consists of an 8" floppy disk with 1 MB of storage.

In addition, you'll find our 83/80 delivers increased performance through its Dual ported full-track disk buffer and proprietary controller circuiting. More users can access with better response time.

It's also very well-educated. Our 83/80 can read or write up to an entire track of data in a single disk rotation, regardless of where the disk-head settles on a given track.

That's smart.

The C programming language comes standard with UNIX, of course. Other optional languages include FORTRAN-77, PASCAL, RM/COBOL®, LISP and BASIC. And that's just for starters. Optional software includes data base and administrative packages like INGRES and UNIFY.

And the sticker price? Quantity 10 at \$14,693.

For further information, please write or telephone our Marketing Department at 415/549-3854.

We'll be glad to tell you about one powerful microsystem that's revved up and ready-to-go.



DUAL

Dual Systems Corporation
2530 San Pablo Avenue
Berkeley, CA 94702

*UNIX is a trademark of Bell Laboratories.

© RM/COBOL is a registered trademark of the Ryan McFarland Corporation.

Dual-port RAM board

Multibus and Sam-Bus compatible, the Sam-DPRAM allows simultaneous access of the memory bank through either bus. It has a typical access time of 250 ns and a maximum cycle time of 350 ns. Memory capacity can range from 128 Kbytes to 2 Mbytes. Parity checking

detects any single-bit errors, then the CPU reads input ports to determine the physical address of the error. Both buses provide a 24-bit addressing range for 16 Mbytes of addressing capability. The board costs \$2400. **SGS USA**, 1000 E Bell Rd, Phoenix, AZ 85022. **Circle 288**

INTERFACE

Cluster controller



The 4970 enables ASCII graphics terminals to operate in IBM environments. Together with communication software, the controller connects Tektronix terminals to the SNA as if they were IBM 3270 type terminals. It supports up to four async devices on a single polled sync line with transmission rates up to 9.6 kbits/s. Software provides terminal to host communications with SNA network compatibility and SDLC protocol. Other features include error-free transmission with auto error recovery. Price is \$6200. **Tektronix, Inc**, PO Box 500, Beaverton, OR 97077. **Circle 289**

Frustrated with eye patterns? Time interval analysis advances from

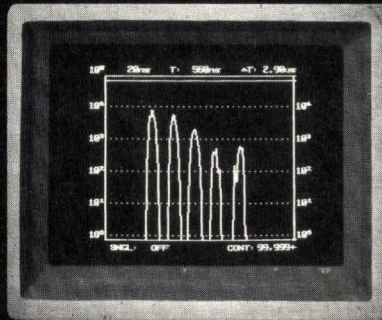
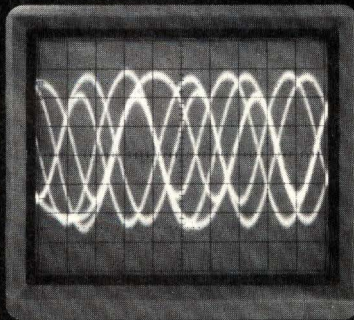

art ... to science

From frustration to precision and productivity . . .

Kode has a whole new answer to your dynamic, real-time measurement needs for time interval analysis — the TIA 2010 and TIA 2001. And we deliver with systems that you'll find are "user-friendly", portable and, last but not least, low in cost.

Qualitative vs. quantitative . . .

Traditional eye pattern formats are limited to qualitative indications — revealing only good, bad, or marginal performance. The TIA 2010 and TIA 2001, rendering event-by-event histograms, are quantitative tools. They leave subjectivity and guesswork behind and usher in an unprecedented degree of accuracy for design and test applications.

Kode's time interval analyzers offer you . . .

- Detailed statistics to quantify bit distribution with accuracy and precision.
- Capture of isolated, single events. Infrequent events are not only detected, but shown to the operator and quantified.
- Aid in pinpointing design causes of bit distortions.
- Graphic screen displays that tell you everything you need to know at a glance.

■ On-board analysis storage for future reference and screen comparison.

To make your time interval analysis more effective, write Dick Miller at Kode, Inc., 2752 Walnut Avenue, Tustin, California 92680, or call Dick at (714) 730-6901.

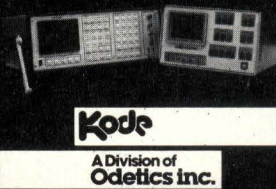

Kode
A Division of
Odetics Inc.

Bringing science to time interval analysis.

Parallel interface card

Designed for the STD bus, the DSTD-408 is compatible with the QIC-2 ¼-in. tape interface protocol. A Z80 DMA controller chip gains transfer speeds up to 88 Kbytes/s required for the 90-in./s streaming tape drives. It features an 8-bit data bus with a 9th parity bit. Seven control signals plus two handshake signals are supported. Both 2.5- and 4-MHz versions are available. Pricing is \$225 in quantities of 100 or more. **Dy-4 Systems Inc**, 888 Lady Ellen Pl, Ottawa, Ontario, Canada K1Z 5M1. **Circle 290**

Controller for STD bus

Model M/E200 features two RS-232 serial ports with software selectable independent baud rates. It has true EIA levels on transmit data, receive data, clear to send, and data terminal ready. Three 28-pin byte-wide memory sockets provide space for onboard EPROM and RAM. Memory can be switched out in software for boot-up to RAM-based disk based operating system. DIP switch selects GPIB address and options. Interface board costs \$390. **Mitchell Electronics**, Rte 4, PO Box 39, Athens, OH 45701. **Circle 291**

Network software

Liaison family includes an operating system, device servers, and development tools. Features include hardware independence, sharing of programs and data, as well as disks and printers. Networks are peer to peer and each workstation functions as an independent self-contained node. The software provides various services: locator, to find nodes in the network and establish connections; channel, to handle two-way, point-to-point communication; and socket, to provide best-effort transmission. **SofTech Microsystems, Inc.**, 16885 W Bernardo Dr, San Diego, CA 92127.

Circle 292

Software for 68000

Designed to support applications development on the 16-bit 68000, Microbench software includes a relocating assembler, linking loader, librarian, and object file formatter. Assembler is source compatible with 68000 assembly language, supports macro and conditional assembly capabilities, cross-reference listings, and a macro library. Object-file formatter produces binaries in compatible formats to use with PROM programmers and emulation systems. Perpetual license fees start at \$2200 including documentation. **Virtual Systems, Inc.**, 1500 Newell Ave, Walnut Creek, CA 94596.

Circle 293

Language for scientific computing

DEQSOL stands for differential equation solver language, designed for numerical simulation applications. It uses array processors, a DEQSOL translator, and a Fortran translator program. The software reduces the number of lines in a program and decreases the computing time required by array processors. The language consists of 20 parameter instruction commands. The translator is written in Pascal and is about 25,000 lines long. **Hitachi America, Ltd.**, 1800 Bering Dr, San Jose, CA 95112.

Circle 294

Get your own

If you're reading someone else's copy of Computer Design, why not get your own? To receive a subscription-application form, circle 504 on the Reader Inquiry Card.

Improved TSX-PLUS release

Version 4.0 increases virtual address space, improves user security, and introduces DEC RT-11 compatibility. The operating system creates a multi-user, multitasking RT-11 environment. It addresses up to 4 Mbytes of main memory on PDP-11 systems that have either the extended Unibus or the 22-bit Q-bus together with the PDP-11/23 CPU.

Software supports up to eight logical disks per user, and each user has eight distinct files arranged either hierarchically or in parallel. TSX-PLUS costs \$2000; an annual \$500 fee buys support and the option to order upgrades. **S&H Computer Systems, Inc.**, 1027 17th Ave S, Nashville, TN 37212.

Circle 295

Identify with Identicon

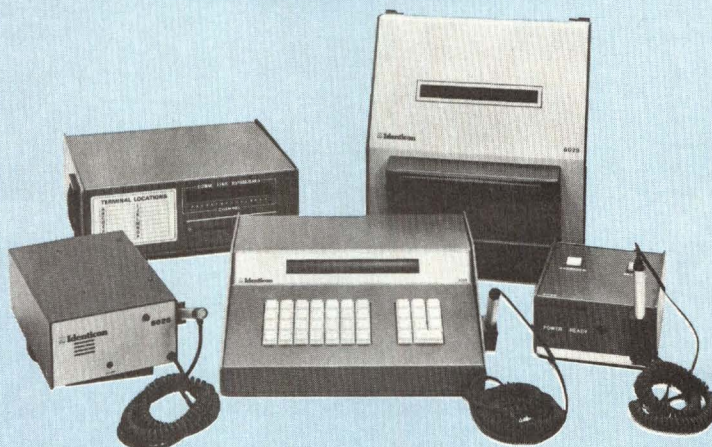

Bar Code Reading Systems' Components

Identicon's full line of high quality components, compatible with your host computer, can reduce costs and increase speed, accuracy and productivity. Identicon, a division of Vertex Industries, has up-graded all products, added new ones and plans to add even more.

Available now:

Model 3000	Visible Light Pen
Model 3020	Second Source Light Pen
Model 6026	Integrated Stand-Alone Terminal
Model 6028	Intelligent, Multi-Function Data Collection Terminal
Model 6029	Time and Attendance Terminal
Model 6030	Single Function Data Collection Terminal
Model 6035	Data Collection Multiplexer
Model 9010	O.E.M. Bar Code Reader

Coming soon:

Hand-held laser scanner • Fixed laser scanner • Portable data recorder

For complete information, phone or write: Identicon, 23 Carol St., P.O. Box 1123, Clifton, N.J. 07014. • (201) 472-2121 TWX: 710 989-7021



Identicon
BAR CODE READERS

A DIVISION OF VERTEX INDUSTRIES



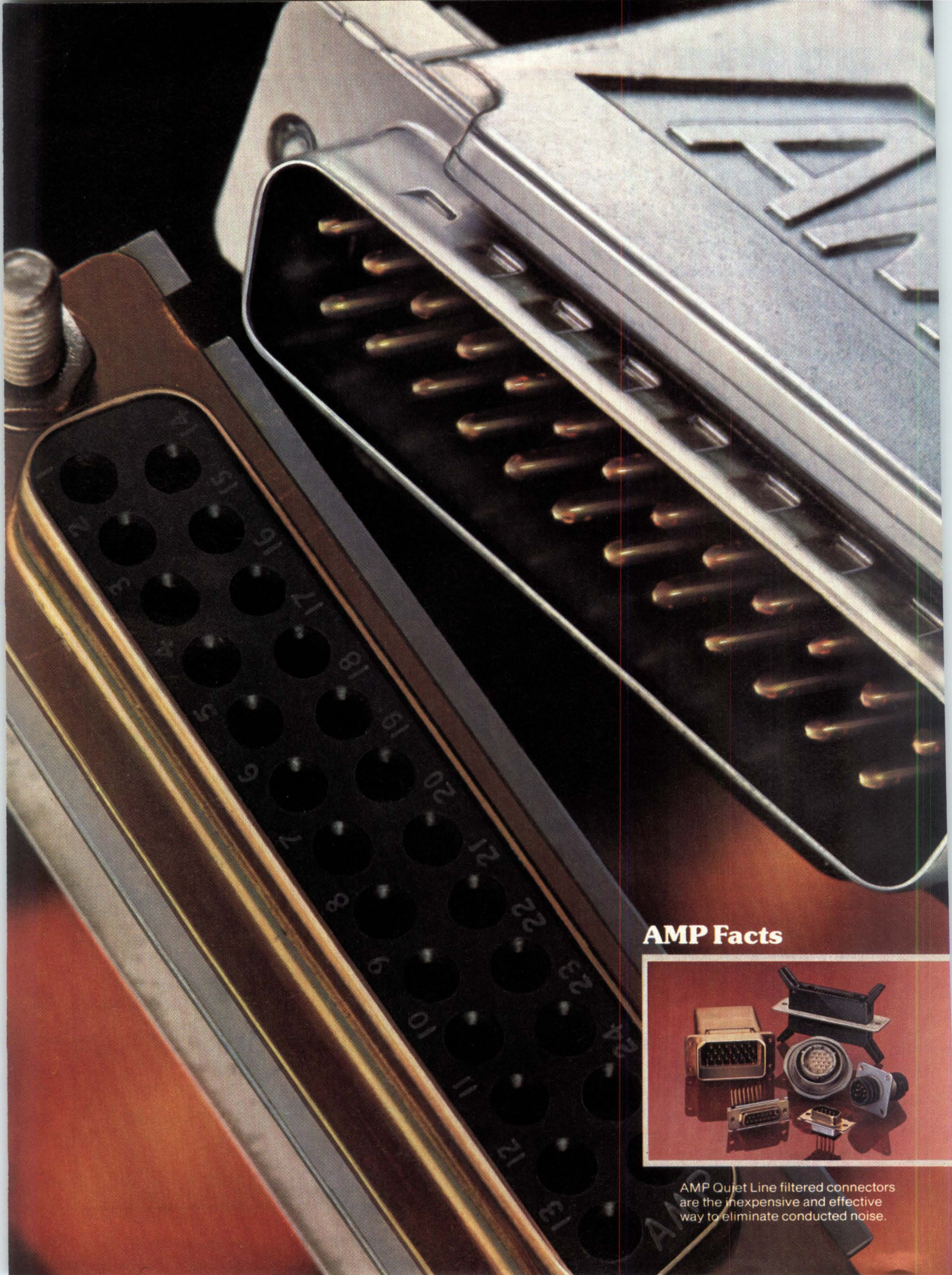

AMP Facts



AMP Quiet Line filtered connectors are the inexpensive and effective way to eliminate conducted noise.

COST-EFFECTIVE QUIET.

AMP filtered and shielded connectors stop EMI coming and going.

Electromagnetic crackles, blips and zaps can scramble a computer's memory, garble communications and destroy IC's. And for years, AMP has been applying uncommon talents to solving this common problem.

To help ensure your own system doesn't radiate noise that FCC regulations forbid, we can now supply shielded versions of connectors that are the standards of the industry. In every size and style you might need, including high density, subminiature and circular types. And they're all designed to deliver the plus performance you expect from AMP.

The AMP attack on EMI goes beyond shielding to stop conducted interference as well. Unique one-piece filter contacts built into AMP connectors absorb and dissipate noise, letting only pure signals through, often eliminating the need for special cables and auxiliary filter circuits.

You get this premium performance with termination economies that AMP has pioneered for half a century.

For complete shielded and filtered facts, call the AMP Information Desk at (717) 780-4400. AMP Incorporated, Harrisburg, PA 17105.

AMP means productivity.

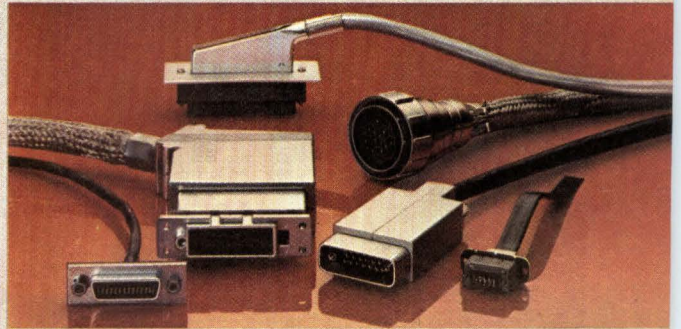
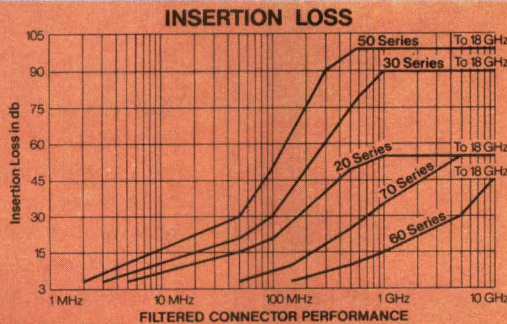
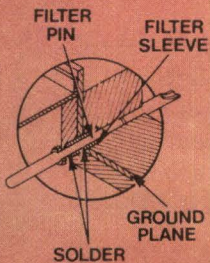

You can choose the insertion-loss vs. frequency characteristics you need.

CIRCLE
NUMBER
10

A complete range of shielded styles, including post/receptacle configurations.

Micro/mainframe software link

Solving the problems of overloaded IBM mainframes, slow terminal response time, and mainframe downtime, the m3278/SPF combines mainframe communication with local computing power. Communication occurs with the PCOX communication board and CXI software.

It emulates the 3278 and implements the complete micro/SPF software. This software provides a full-screen text editor. A parameter specification option redefines program function keys and a browse option allows full scroll in all directions. **Phaser Systems, Inc.**, 24 California St., San Francisco, CA 94111. **Circle 296**

Expanded graphics capabilities

Subroutines and utilities for developing hardware-independent microcomputer graphics applications make up the GSS-toolkit. A kernel system following the GKS syntactical protocol addresses lower level graphics primitives. When used with GSS-drivers software, the system can be graphic-ported across machines running the MS-DOS operating system. A plotting system helps to create charts, and a window manager helps develop multiple viewports. **Graphic Software Systems, Inc.**, 25117 SW Parkway, Wilsonville, OR 97070. **Circle 297**

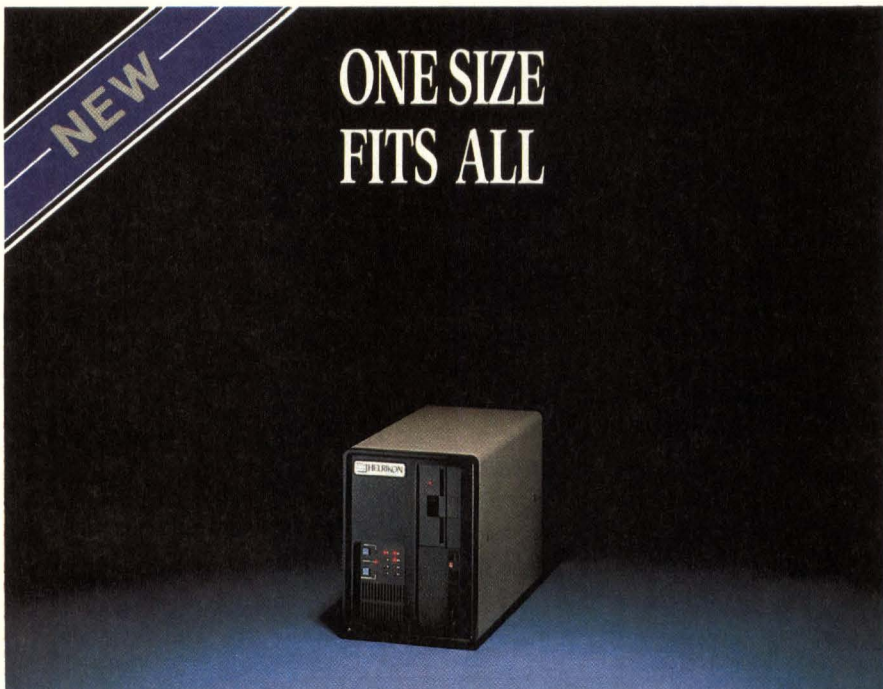

Heurikon presents Minibox - a multiuser UNIX workstation based on its powerful HK68™ single board microcomputer and Uniplus+™ UNIX System III or System V operating system with Berkeley enhancements.

Designed with the OEM in mind, *one size fits all*. Both compact and flexible, the Minibox includes within its 10.5" w x 13.9" h x 20.5" frame a 200 or 400 watt power supply, six slot Multibus™ card cage, (4-5 available for user use!), single double density floppy disk drive, streamer tape drive, and 31 or 65 Mbyte Winchester drive (expandable to 280 Mbytes). All this within the same cabinet! System status LEDs on the front panel inform the user of CPU and disk drive activity.

With Uniplus+™, Minibox becomes a flexible and affordable tool for program development, text preparation, and general office tasks. Included is a full "C" com-

piler, associated assembler and linker/loader. Optional languages are:

Macro assembler, ISO Pascal compiler, FORTRAN-77 compiler, RM-COBOL™, SVS BASIC (DEC BASIC compatible interpreter), SMC BASIC (Basic-Four BB3 compatible interpreter), and Ada™. Other utilities include UltraCalc™ multiuser spread sheet, Unify™ DBM, Ethernet™, and floating point processor. Alternate operating systems available are PolyForth™, Regulus™, CP/M 68K™, and others.

*UNIX is a trademark of Bell Laboratories. Unify is a trademark of Unify Corp. UltraCalc is a trademark of Olympus Software. Ethernet is a trademark of Xerox Corp. Uniplus+ is a trademark of UniSoft Corp. PolyForth is a trademark of Forth, Inc. Regulus is a trademark of Alcyon Corp. CP/M-68K is a trademark of Digital Research. Ada is a registered trademark of the U.S. government, Ada Joint Program Office. RM-COBOL is a trademark of Ryan-McFarland Corp. HK68 is a trademark of Heurikon Corp. Multibus is a trademark of Intel Corp.

**MINI
BOX**

HEURIKON
CORP

3001 Latham Drive
Madison, WI 53713

Telex 469532

800/356-9602
In Wisconsin
608/271-8700

© 1983

Transportable compilers

Fortran and C compilers are fully transportable from workstation to supermini. The Fortran VII for edition VII workbench is source-coded compatible with all OS/32 Fortran system compilers. It is possible to develop and test programs in a realtime environment for optimum runtime performance. The C version is an optimizing compiler that takes advantage of the Series 3200 architecture for fast application processing. C version is priced from \$3400 to \$7000, while the Fortran version is \$3400. **Perkin-Elmer Corp., Data Systems Group**, 2 Crescent Pl., Oceanport, NJ 07757. **Circle 298**

Cross compiler in C

Hosted on the VAX under Unix, the compiler targets the 68000 CPU. The package includes 68000 compiler, assembler, linker, and full runtime library. It features a C processor, 32-bit pointers, data initialization, absolute load maps, and global symbols listing. For realtime applications, it features tightly generated ROMable code. The compiler makes five passes, yet is time competitive with other compilers. **The Destek Group**, 830 E Evelyn, Sunnyvale, CA 94086. **Circle 299**

Share your knowledge
Other system designers face the same problems you've already solved. You could help them by writing a technical article for Computer Design. For a free copy of our Author's Guide, circle 500 on the Reader Inquiry Card.

Mouse Controls Cursor Control The Easy Way

Transferring files PC to mainframe

When used with protocol converters, FileLynx/3278 makes the IBM PC or PC compatibles emulate an IBM 3278-2 terminal. All function and cursor keys are supported. Users can transfer an entire file to or from the mainframe automatically and a variable number of lines per screen can be transferred. A user-friendly configuration mode stores all parameters. Software supports several auto-dialing modems. It requires a minimum of one serial card, 64 Kbytes of memory, and any PC-DOS version. Price is \$200. **Local Data**, 2701 Toledo St, Torrance, CA 90503.

Circle 300

Micro program for system design

Tutsim is a block diagram oriented simulation program for continuous dynamic systems. Users can build models from engineering equations or describe their system with approximately 40 types of program block elements. To enter the program block, users specify parameters in line format. The program then does a model simulation. Output is graphic or numerical, and most parameters can be changed by one or two line commands. Micro versions range from \$475 to \$574. **Applied i**, 200 California Ave, Palo Alto, CA 94306.

Circle 301

Software debugger for 68000

Probug allows the user to print and alter memory and registers; copy, fill, and search memory; assemble and disassemble instructions; and control program execution. The debugger/monitor downloads programs from and writes programs to a host computer, and boots a disk operating system. The user can set observation points to halt program execution when a specified memory location changes. A user manual comes with the 16 Kbytes of firmware. Price is \$250. **SBE, Inc**, 4700 San Pablo Ave, Emeryville, CA 94608.

Circle 302

Talk to the editor

Have you written to the editor lately? We're waiting to hear from you.

They operate on any surface. They're easy to use. And they're durable. They're the new Series 122 mouse for cursor control. From Measurement Systems, of course.

The key feature of these versatile user friendly position entry devices is the long-life x and y optical encoders. They're independently driven, with very low friction and torque requirements. That makes the controls exceptionally easy to use. And it reduces to a bare minimum the chance that dirt or loose materials will interfere with normal operation.

You can get any of the Series 122 mouse controls with quadrature square wave output, scaled pulse output, variable pulse rate or coded digital, in up to 3 function switches. Standard counts range from 20 to 300 per inch of mouse motion.

Once you've seen these controls in action, you'll be a confirmed mouseketeer, too. Contact us for more information.

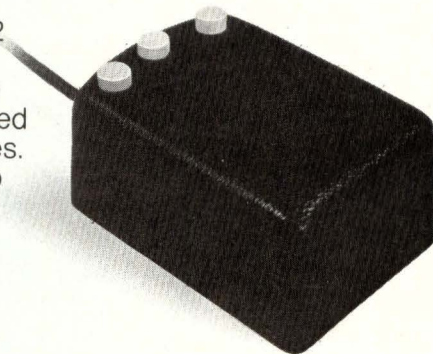

MS Measurement Systems, Inc.
121 Water Street, Norwalk, CT 06854 203-838-5561
CIRCLE 123

We will train you in UNIX™ and the "C" Language

...And, back it with 50 years of technical experience.

The leader in on-line data information equipment and applications for over 50 years, Bunker Ramo now provides a training course which gives you:

- A one terminal/one user classroom environment
- Proven hands-on learning techniques
- Comprehensive textbooks
- Complete course documentation
- State-of-the-art instructional methods
- Special group registration rates

Current course offerings include:

- Introduction to the UNIX environment (5 days)

UNIX is a trademark of Bell Laboratories

- Introduction to "C" programming language (5 days)
- Advanced UNIX methods (5 days)
- Advanced "C" methods (5 days)
- Management/Marketing one day UNIX workshop
- Practical Data Communications (for service personnel)
- Custom Technical Courseware Development

For a detailed prospectus, call, write or return coupon to:

Bunker Ramo Information Systems
Training Services Group
37 Nutmeg Drive, Trumbull, CT 06609
(203) 386-2600

I am interested in your course offerings

- mail me your prospectus which includes course descriptions & registration material.
- call me so that we can discuss my particular needs.
- register _____ students in the introductory courses mentioned above on (UNIX) (and) (the C language) during the month of _____, and call me with all details, dates, and confirmation.

Name _____

Company _____

Address _____

Phone _____

**Bunker Ramo
Information Systems**
An **ALLIED** Company



**TANDBERG DATA
TAKES THE
NEXT STEP**

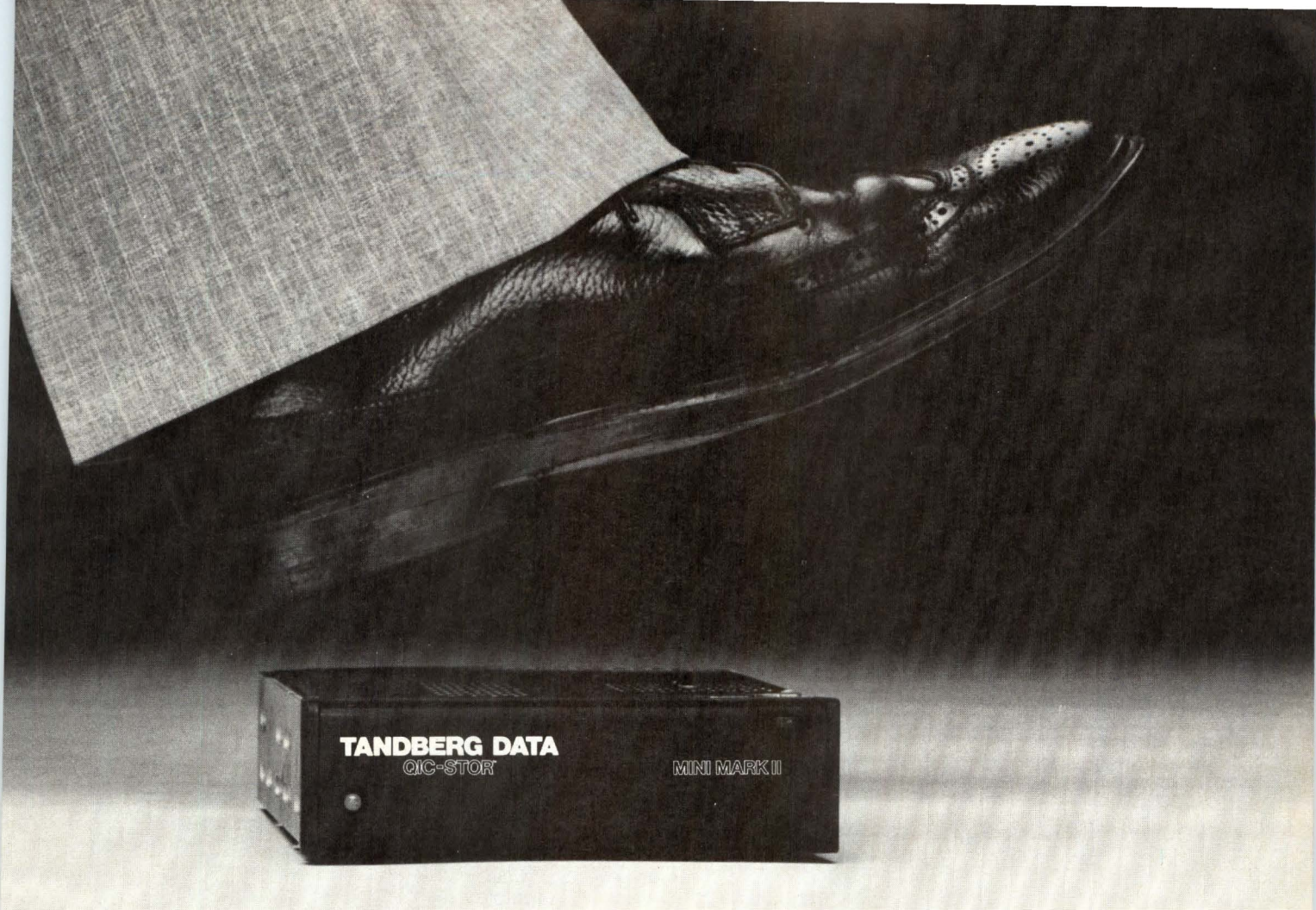

The first step, if you remember, was the introduction of our QIC-02 8", four- and nine-track tape drive. This 1/4" streamer set new standards for data integrity and accuracy. (You can actually stand on one.)

Our next step, the QIC-STOR™ Series, finally brings 100% QIC-compatibility to the 1/4" streamer market. And now with QIC-02 and QIC-24, our newly announced Mini-Mark II™ packs incredible performance and reliability

into a half-high 5 1/4" form factor. It has all the best features of our new 8" Mark II™, including precise track locating and rugged cartridge locking/loading to totally eliminate the machine interchangeability problems that have plagued the industry. You get all this, plus capacities of up to 60 megabytes on a single 1/4" tape cartridge!

We've stepped up our facilities and capabilities too, just to keep up with demand. But that's another story. If you'd like the full story on our growing lineup of QIC-STOR streamers, you'll have to take the next step and contact Tandberg Data, Inc., DATA STORAGE DIVISION, 571 North Poplar, Suite H, Orange, CA 92668. (714) 978-6771.

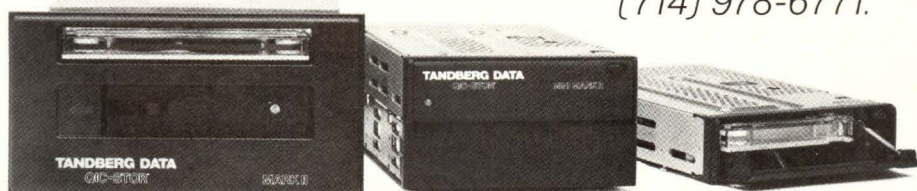

TANDBERG DATA
QUALITY IN EVERY BIT.

If you're going to gripe about the quality of the air you breathe,

at least take your cigarette (and your foot) out of your mouth first.

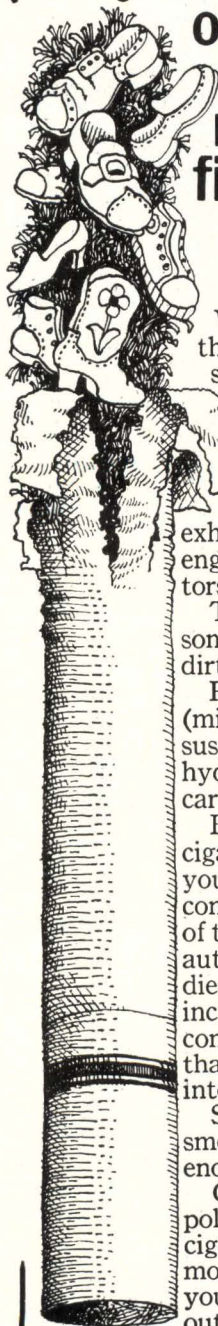

When you think of the stuff that makes air dirty, you think of auto exhaust, diesel engines, incinerators; right?

They contain some pretty bad dirt-makers like: Particulates (minute solids suspended in air); hydrocarbons; carbon monoxide.

But the cigarette smoke you inhale contains more of this stuff than auto exhaust, diesel engines and incinerators combined. And that's straight into your lungs.

So you see, smoking is dumb enough.

Gripping about pollution with a cigarette in your mouth can get you laughed out of town.

AMERICAN CANCER SOCIETY

THIS SPACE CONTRIBUTED BY THE PUBLISHER

SYSTEM COMPONENTS/PERIPHERALS

Instant camera for CRTs

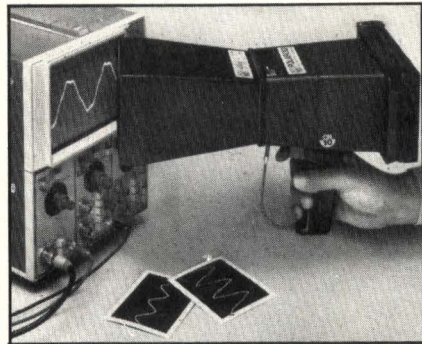

A versatile, handheld camera takes pictures of displays in industrial, scientific, and security applications. The CR-10 model 33-30 shoots 3 1/4-in. x 4 1/4-in. instant film, black and white, or color. Interchangeable hoods size images from various scopes and CRT screens. A built-in supplementary lens in each hood matches image magnification to film size. The camera costs \$349; hoods are \$49 each. **Polaroid**, 575 Technology Sq, Cambridge, MA 02139. **Circle 303**

Advanced ASCII terminals

The VT200 family offers three models that will have full VT100 emulation capabilities. The VT220 is a two-piece monochrome text unit. The VT240 has all the text features of the 220 plus bit-mapped graphics. The VT241 has all the features of the 240 and, in addition, a color display. This version offers an optional integrated modem that features auto-dial and auto-answer. Monitors include reverse video and character highlighting, and function keys are programmable. Prices range from \$1295 to \$3195 depending on model. **Digital Equipment Corp**, 10 Main St, Maynard, MA 01754. **Circle 304**

Band printers

Estimated mean time between failure for the M304X series is 4000 hours at 1200 lines/min and 6000 hours at 600 lines/min. Forty-eight-character models print 390, 750, 1090, or 1300 lines/min, while 64-character models print 300, 900, or 1200 lines/min. Standard features include type-band exchange and auto-identification of four print bands. The operator's panel indicates errors detected automatically. Each model comes with a Centronics, Dataproducts, or RS-232-C interface. In quantity, the

1200-line/min model costs below \$8000. **Fujitsu America, Inc**, 3075 Oakmead Village Dr, Santa Clara, CA 95051. **Circle 305**

Graphics tablet

The Pen Pal has a 100 percent transparent writing surface so the user can place menus, artwork, and drawings under the digitizer. Sizes range from 6 x 6 in. to 24 x 36 in. and are accurate to better than 1 percent, with resolution better than one mil. Speeds can be obtained to 1000 coordinate pairs/s. It is unaffected by stray emi or rfi fields and never requires magnetic biasing. Low power operation allows the use of cordless pens and cursors. **Scriptel Corp**, 3660 Parkway Ln, Hilliard, OH 43026. **Circle 306**

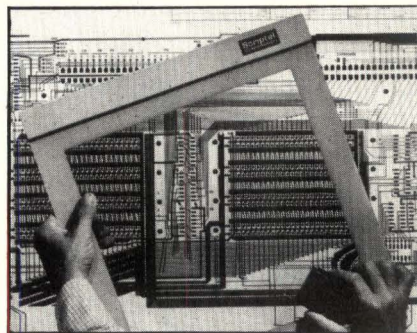

Enhanced display terminal

The ET 100B emulates the VT100 series, including advance video option, identical keyboard layout, and printer port. None of the features require software changes. In addition, the terminal provides 16 user programmable function keys, easy to use menu setup mode, and audio signal that indicates data received. DIN standard as well as other international keyboards are available. **TEC, Inc**, 2727 N Fairview, PO Box 5646, Tucson, AZ 85703.



Circle 307

EPSON QUALITY PRODUCTS FOR THE OEM.

INTRODUCING THE EXTRAORDINARY EPSON OEM FAMILY OF FLOPPY DRIVES

SERIES	SMD 100		SD 500			SD 300
MEDIA SIZE	3½"		5¼" (1/2 High)			5¼" (1/3 High)
	4" x 1.57" x 5.98"		5.75" x 1.6" x 7.68"			5.75" x 1.1" x 9.27"
Max. Capacity (2 Sides) (Unformatted)	500 KB	1000 KB	500 KB	1000 KB	1604 KB	500 KB
Drive Motor Speed	300 RPM	300 RPM	300 RPM	300 RPM	360 RPM	300 RPM
Track Density	67.5 TPI	135 TPI	48 TPI	96 TPI	96 TPI	48 TPI
Access Time	6 msec	3 msec	6 msec	3 msec	3 msec	15 msec

500KB to 1.6MB and access times down to 3 msec. And the one-third height 5¼" drive is the industry's slimmest.

But that's only part of the story. What really makes them extraordinary is the fact that they're Epson drives. Designed and built by the people who have made "quality in quantity" their trademark around the world.

That means they're designed and engineered with such state-of-the-art features as noise and RF shielding, ultra-high precision head positioning and loading, perfect disk centering, reduced power consumption and heat generation. But, even more importantly, it means they're manufactured by the people who have established the lowest rejection rate in the industry. When you buy Epson, you buy confidence.

If you'd like more information about the extraordinary Epson family of floppy drives and how they can solve your storage problems, write or call us today.

SW Region (714) 250-0111 • NW Region (408) 985-8828
SE Region (404) 458-9666 • NE Region (617) 245-8007
CENTRAL Region (815) 338-5810

Extraordinary is the best word we could find to describe the new Epson family of 3½" and 5¼" floppy disk drives. Because there is nothing ordinary about them.

The 3½" drives, for instance, feature two-sided capacities up to 1MB. And some draw so little power they can operate on batteries.

The half-height 5¼" drives offer capacities from

EPSON
EPSON AMERICA, INC.
OEM Products Division
Peripherals Group
3415 Kashiwa Street, Torrance,
CA 90505 (213) 533-8277
Telex: 182412

For the Love of Life

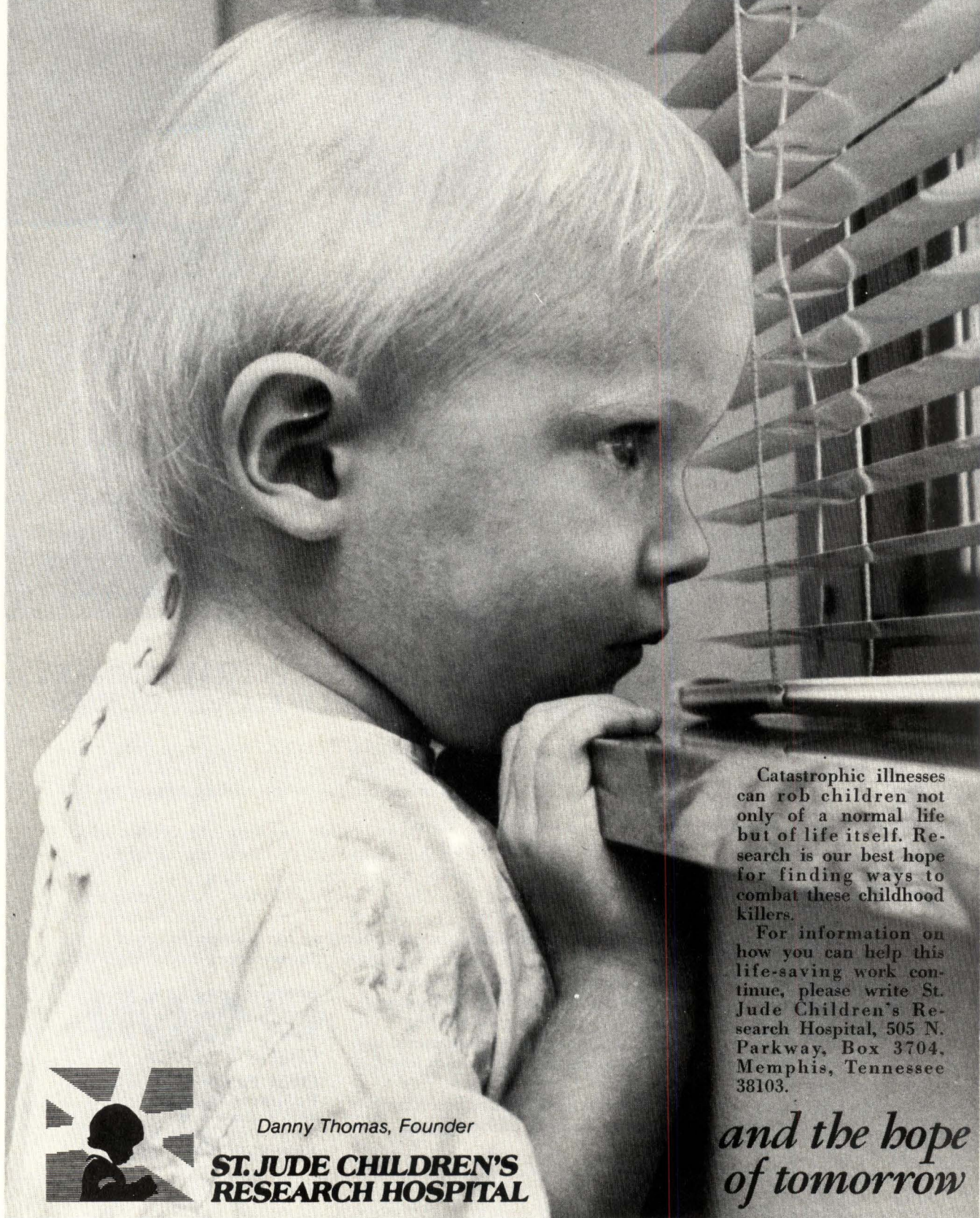

Catastrophic illnesses can rob children not only of a normal life but of life itself. Research is our best hope for finding ways to combat these childhood killers.

For information on how you can help this life-saving work continue, please write St. Jude Children's Research Hospital, 505 N. Parkway, Box 3704, Memphis, Tennessee 38103.



Danny Thomas, Founder

**ST. JUDE CHILDREN'S
RESEARCH HOSPITAL**

*and the hope
of tomorrow*

Plotters and hardcopy unit

The online electrostatic plotter produces an E-sized, full-color plot in 8 min. Sixty-four line codes and fill patterns create 256 color patterns in four colors. A color pen plotter features a high speed writing system for graphics. Fiber tip or liquid ink draft pens plot up to 24 in. of graphic data/s. The color hard copier produces A-sized copies directly from design stations without host support. Copies are made with oil-based ink in a thermal ink transfer process. It makes 99 copies unattended, and downloads screen images from a video device in about 0.5 s. **Calma Co**, 2901 Tasman Dr, Santa Clara, CA 95050. **Circle 308**

Color graphics terminal

The 6411 comes with a desk-side console, a 19-in. monitor, and a keyboard. In the basic configuration, it has four refresh memory planes, and allows simultaneous display of 16 colors chosen from a palette of 4096. With the addition of four optional refresh memory planes, 256 colors from a palette of 16 million can be displayed, as well as shadows and dimension, in solid objects on the screen. Display resolution is 1280 x 1024 pixels, and can be zoomed in integer steps between 1:1 and 16:1. The system costs \$14,995. **Ramtek Corp**, 2211 Lawson Ln, Santa Clara, CA 95050. **Circle 309**

DEVELOPMENT SYSTEMS

Low price CAD system



Based on Data General's Desktop Generation, ICON features software to create, preview, edit, store, and recall graphics. Available in single- and dual-user configurations, each workstation has an integral digitizer with menu and two tilt and swivel monitors. The display measures 19 in. with 1280 x 1024 resolution. Complete application packages include programs for PC board design, mechanical and electrical design, and word processing. Price per station in a four-workstation configuration is \$37,250. **Summagraphics Corp**, 35 Brentwood Ave, PO Box 781, Fairfield, CT 06430. **Circle 310**

Custom RAM/ROM cells

A standard-cell technique creates custom VLSI circuits with onchip RAM and/or ROM tailored to specific requirements. Designers enter only macro definitions of memory size and organization. The zyP system automatically generates both the artwork and the simulation model. Construction occurs by assembling body, control, and end-cap cells. Each cell type comes in 32-, 64-, and 128-bit deep configurations for RAM, and 512-, 1024-, and 2048-bit configurations for ROM. **Zymos Corp**, 477 N Mathilda Ave, PO Box 62379, Sunnyvale, CA 94088. **Circle 311**

Monochrome graphics terminals



The IGT-1000M series features a 15-in. raster scan screen with P-39 green phosphor and 1024- x 780-pixel resolution. The terminal emulates Tektronix 4010 series with Plot 10 software compatibility plus commands to draw rectangle, arc, and circle. Images can be selectively erased or blinked, and a closed polygon filled. Options include 17-in. and 20-in. monitors, 1024 x 1024 resolution, tablet and lightpen input for high speed menu selection, and cursor control. Unit price is \$3995. **Infocom Systems Inc**, 6001 Gulf Fwy, Houston, TX 77023. **Circle 312**

Mid-range graphics system

The 19-in. color raster Whizzard 3355 offers 2-D graphics, 1024- x 1024-pixel resolution, and realtime dynamic transforms. A 12-bit (4096 x 4096) virtual addressing system accesses the memory mapped display pixel by pixel. Architecture is based on a dual-bus graphics engine with host computer interface, 32-bit graphics processor, and local processor. The system is \$22,500. **Megatek Corp**, 9605 Scranton Rd, San Diego, CA 92121. **Circle 313**

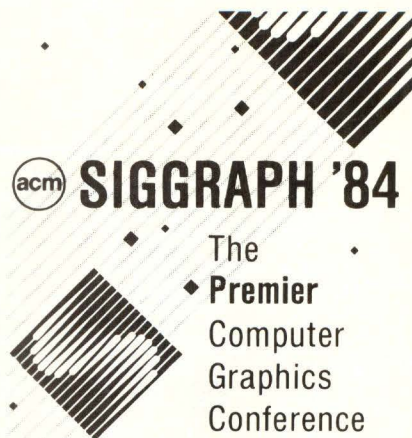

SIGGRAPH '84

The
Premier
 Computer
 Graphics
 Conference

◆ 1984 Exhibition

The most intense display of high performance computer graphics equipment for current and future applications.

July 23-27, 1984

Minneapolis, Minnesota

For information, contact the
 ◆ SIGGRAPH '84 Conference Office
 111 East Wacker Drive (A)
 Chicago, Illinois 60601
 (312) 644-6610
CIRCLE 121

In-circuit emulator

The Mice-II line's 68008 model program development/debugging system operates standalone or together with a computer system. Its 68008 micro lets the user run the target 68008 micro system transparently in realtime with no wait states and using no memory space. It features two hardware breakpoints, resident assembler/disassembler, realtime forward/backward trace up to 2048 cycles, and a 32-Kbyte emulation memory expandable in 32-Kbyte segments. Unit is \$3995. **MicroTek Lab, Inc**, 17221 S Western Ave, Gardena, CA 90247. **Circle 314**

Realtime 8086/88 development

Sphere ROM-based software system combines the functions of operating system, multitasking executive, high level language, native assembler, and development tools in one package. Using only 16 Kbytes of ROM, 2 Kbytes of RAM, and a terminal port, it provides complete tools for designing, coding, testing, and implementing realtime applications. Time critical routines can be written in the native assembler of the target micro, then mixed with HLL code for maximum realtime performance. Prices start at less than \$3000. **Infosphere, Inc**, 4730 SW Macadam Ave, Portland, OR 97201. **Circle 315**

VIBRATION ISOLATORS

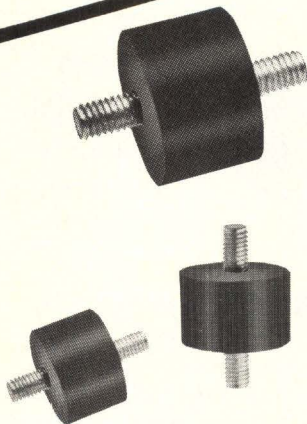

Minor Rubber makes performance engineered vibration dampeners to make your product perform better.

Choose from our selection of nearly 1,000 different components. New catalog available illustrating 8 major styles PLUS compression/shear data. Compounds to meet your needs.

Minor Rubber can make your product BETTER!

- Smoother Operation
- Longer Equipment Life
- Less Downtime
- Greater Productivity



FREE ILLUSTRATED CATALOG AVAILABLE

MINOR RUBBER CO. INC.

49 Ackerman Street
Bloomfield, N.J. 07003
In NJ—(201) 338-6800
Toll Free (800) 637-8574

In Calif.—(213) 306-8063
Toll Free (800) 527-0260

In Texas—(800) 442-5840
Outside TX (800) 527-0260

CIRCLE 119

SYSTEM COMPONENTS/CONTROL & AUTOMATION

Data acquisition of PC

Sample and hold system DT2818 provides simultaneous analog I/O capabilities as well as digital I/O and clock functions. Analog input throughput rate is up to 27,500 samples/s. The user can take a snapshot of up to four high-level analog input channels, freezing their values instantaneously within ± 5 ns. Also included are two 12-bit D-A converters, two 8-line digital I/O ports, and an on-board programmable clock for scanning inputs or for multiple output conversion. Single unit price is \$1585. **Data Translation**, 100 Locke Dr, Marlboro, MA 01752. **Circle 316**

Digital dc servo controller

Micro-based FPC-1800 interfaces to any computer, micro, or standard bus protocol. Controller/computer link consists of 8 bidirectional bus lines, plus read, write, and chip select control. Point-to-point positioning and damping are both programmable. Instruction set commands control accurate system positioning within ± 8 million counts from a home reference, stepping a programmed number of counts, moving at a constant velocity, and moving to home or seeking a limit switch. Unit is \$735 in 100-piece quantities. **Finell Systems, Inc**, 1190-S Mountain View-Alviso Rd, Sunnyvale, CA 94089. **Circle 317**

Measurement and control system

With micro, realtime software package, Fortran or Pascal high level language, and networking capabilities, the Control/1000 is designed for industrial automation. Applications include process control, machine automation, and control with a medium to high sensor point count. The micro has a 1-MIPS CPU and 512 Kbytes of memory. Software reduces much of the protocol needed to communicate with function cards. Prices range from \$25,000 to \$150,000 depending on point count. **Hewlett-Packard Co**, 1820 Embarcadero Rd, Palo Alto, CA 94303. **Circle 318**

February Preview

Watch for a special article on microprocessors

Chip program for scanning

A Basic program on a PROM, Autoscan is designed for automatic stop-flow peak scanning, absorbance ratio determinations, and time-programmable wavelength changes. It is intended for use with a variable wavelength detector together with an HPLC system and a computing integrator. The firmware-based system eliminates loading programs from auxiliary storage devices. Applications include confirming the identity and purity of chromatographic components and determining the optimum monitoring wavelength for an analysis. **Spectra-Physics**, 3333 N First St, San Jose, CA 95134. **Circle 319**

DATA COMMUNICATIONS

Fiber optic modems

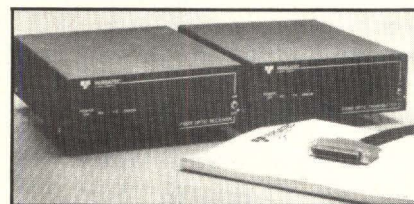

Modems enable online electrostatic plotting up to 2 miles (3 km) from a host computer without repeaters. Model 410 fiber optic system (one transmitting and one receiving modem) is compatible with all Versatec controllers. No special software or protocols are required. Cables must be terminated with SMA 905/906 metallic connectors. Transmission rates exceed 132 kbytes/s and support all Versatec printer/plotters. The system costs \$6000. **Versatec, a Xerox Co**, 2710 Walsh Ave, Santa Clara, CA 95051. **Circle 320**

Small computer LAN

An intelligent Ethernet compatible network interface unit allows PC users to share information and resources. The plug-in board features SNA gateways allowing access to mainframe-based application programs. It also features a shared disk and print servers. The disk server manages the shared access to all files and application programs stored on one or more Winchester at the server station. Diskshare software provides multilevel password protection. The \$850 unit includes MS-DOS networking commands on a 5¼-in. diskette. **Ungermann-Bass, Inc**, 2560 Mission College Blvd, Santa Clara, CA 95050. **Circle 321**

Programmable logic sequencer

By directly replacing the 16R8 PAL, the 82S159 can replace more than two dozen small and medium TTL circuits. The chip is organized as 16 x 45 x 12 with 16 inputs, 45 product terms, and eight registered plus-four combinatorial outputs. Nickel-chromium fuse links on AND/OR gate arrays allow field programming sum-of-products logic. Eight onchip registers permit dedicated or program-controllable flipflop configuration to either T, JK, or D operation. In plastic, the IC costs \$11.95 (100 to 999); in ceramic, \$13.25. **Signetics Corp**, 811 E Arques Ave, PO Box 409, Sunnyvale, CA 94086. **Circle 322**

Communication interface adapter

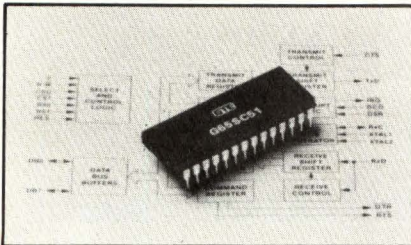

An onchip baud rate generator in the G65SC51 allows 15 programmable rates from 50 to 19.2k baud. A single standard 1.8432 MHz external crystal achieves this performance; an external clock input handles higher baud rates. The chip has programmable interrupt and status registers, full-duplex or half-duplex operating modes, and selectable 5-, 6-, 7-, 8-, or 9-bit transmission rates. Power consumption is 11 mW at 1 MHz and 11 μ W standby. Packaging options include 28-pin plastic, ceramic, or cerDIP at 1 and 2 MHz. Plastic, in 100 or more, costs \$7.90. **GTE Microcircuits**, 2000 W 14th St, Tempe, AZ 85281. **Circle 323**

Skinny static RAM

The hermetic-packaged 2-K x 8 CMOS chip offers savings in circuit board space compared with the standard-packaged 6116. The IDT6116 T DIP is a packaging alternative that features a 300-mil wide, 24-pin package. Because of circuit board space savings, the chip is useful for airborne applications. It is available in four speeds: 70, 90, 120, and 150 ns. In addition, there are two power options: standard at 200 mW and low at 20 mW. Prices are \$18.20 each in 100s. **Integrated Device Technology, Inc**, 3236 Scott Blvd, Santa Clara, CA 95051. **Circle 324**

High speed static RAM

Organized as 16 Kbits x 1, the Am2167 is available in 35-, 45-, 55-, and 70-ns versions. It draws 660 mW power (active) and when deselected by a chip enable, it automatically enters a power down mode. The architecture allows applications in mainframe memories, image processing, and signal processing. All interface signal levels are identical to TTL specs. Packaged in 300-mil, 20-pin plastic, the device is \$25 in 100s. **Advanced Micro Devices Inc**, 901 Thompson Pl, Sunnyvale, CA 94086. **Circle 325**

TEST & MEASUREMENT

Test system for VLSI

A tester-per-pin architecture makes all the test system's resources available at each pin. The MegaOne offers data rates to 80 MHz at each of 256 pins. Each pin has a timing generator, wave formatter, 1 million elements of vector memory, pin driver and comparator, programmable current load, and parametric test unit. In addition, the tester includes a computer system built around multiple 68010 processors and runs Unix Version 4.2 software. **Megatest Corp**, 2900 Patrick Henry Dr, Santa Clara, CA 95050. **Circle 326**

Interactive timing analyzer

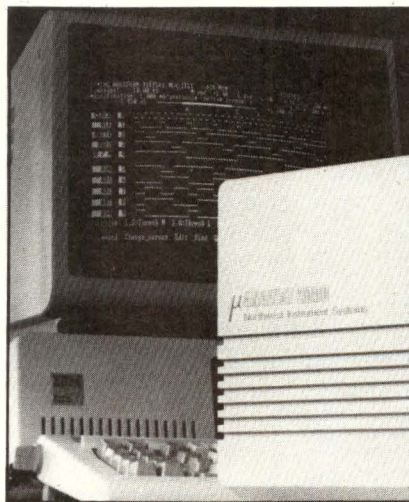

Model 2200 pinpoints faults in hardware during design of micro-based systems. Controlled by the IBM PC, it has 16 timing input channels with a maximum 100-MHz sample rate that uses a transitional timing mode. Trigger modes include triggering on setup and hold time violations.

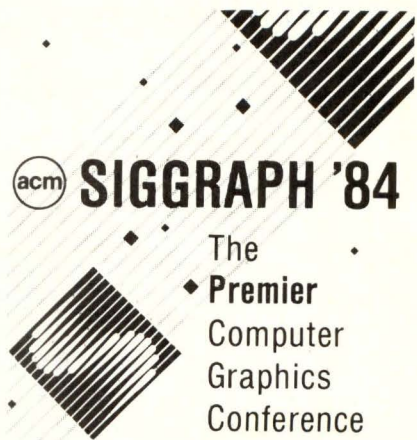

The
Premier
 Computer
 Graphics
 Conference

◆ 1984 Technical Program and Courses

Papers exploring new techniques, panels probing topical issues and courses offering in-depth instruction.

July 23-27, 1984

Minneapolis, Minnesota

◆ For information, contact the
 SIGGRAPH '84 Conference Office
 111 East Wacker Drive (A)
 Chicago, Illinois 60601
 (312) 644-6610

CIRCLE 118

Transitional timing acquisition mode stores data only when a transition occurs on a specified input line or lines; counter measures the time between transitions. Virtual memory scheme permits a 128-Kbyte memory depth. The two-card set plus probes is \$2995. **Northwest Instruments Systems, Inc**, PO Box 1309, Beaverton, OR 97075. **Circle 327**

SYSTEM ELEMENTS

Character module

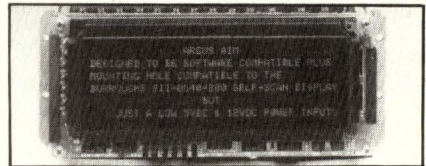

Model 3402-04-320N is a 8-line x 40-character display that requires only 5 Vdc for logic and 11 to 29 Vdc for internal power. The neon-orange characters are formed with a 5 x 7 dot matrix and the entire 96-character ASCII set is displayed. The modules have a micro-based controller that accepts parallel ASCII data from the host. Panel dimensions are 279.4 x 128.3 x 52.2 mm. Total power required is typically 16 W. Price is \$624 in 100s. **Industrial Electronic Engineers, Inc**, 7740 Lemona Ave, Van Nuys, CA 91405. **Circle 328**

“If you want to do OEM computer business in the U.S., you’d better go to the Invitational Computer Conferences in Boston, Dallas, Minneapolis, Orange County, Washington, D.C., Los Angeles, Ft. Lauderdale, ...We do!”

Experienced marketing management knows that the best way to reach the technical decision maker/buyer is to meet him where he lives and works, demonstrate operating equipment and provide him with the technical information he needs. Over the past 12 years successful marketers have found the Invitational Computer Conferences to be the most cost-efficient, effective method of covering their U.S. computer industry customer base.

The exclusive, one-day, OEM conferences will be held in ten major market areas throughout the United States and are attended by a select, invited audience of OEM's, systems houses and quan-

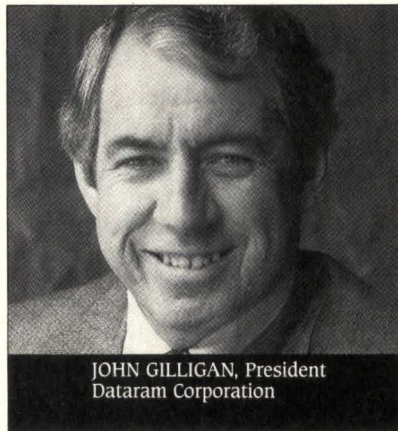

JOHN GILLIGAN, President
Dataram Corporation

tity end users. Guests can attend a variety of technical seminars and view operating displays of the newest computer and peripheral equipment. The informal setting makes it easy to meet with potential customers one-on-one and the simple table-top displays keep exhibit costs at a minimum.

Exhibit your products at the Invitational Computer Conferences with these top companies:

1983-1984 Series

Sept. 13, '83	Newton, MA
Sept. 29, '83	Minneapolis, MN
Oct. 18, '83	Valley Forge/ Philadelphia, PA
Oct. 20, '83	Washington, D.C./ Vienna, VA
Nov. 8, '83	Houston, TX
Nov. 10, '83	Dallas, TX
Jan. 9, '84	Irvine, CA
Feb. 7, '84	Ft. Lauderdale, FL
Feb. 28, '84	Los Angeles, CA
Mar. 1, '84	Palo Alto, CA

For more information call or write:
B.J. Johnson
& Associates, Inc.
3151 Airway Ave. #C-2
Costa Mesa, CA 92626
(714) 957-0171



Adaptive Data &
Energy Systems
Amcodyne, Inc.
Amlyn Corp.
Anadex Inc.
Archive Corp.
AVIV Corp.
Braemar Computer
Devices, Inc.
Cipher Data
Products, Inc.
Control Data Corp.

Cynthia Peripheral
Corp.
Dataram Corp.
Digital Equipment
Corp.
Dysan Corp.
EXO Corp.
Fujitsu America,
Inc.
IBM Corp.
Integral Data
Systems, Inc.

International
Memories, Inc.
Iomega Corp.
KENNEDY
An Allegheny
Int'l Co.
Maxtor Corp.
MegaVault
Micro Peripherals
Inc.
NEC Information
Systems, Inc.

Pertec Peripherals
Corp.
Pioneer Magnetics,
Inc.
Priam Corp.
Printronic, Inc.
Quantum Corp.
Qume Corp.
Raymond
Engineering,
Inc.
ROSSCOMP Corp.

Seagate Technology
Spectra Logic Corp.
Tabor Corp.
Tandberg Data, Inc.
Tecstor, Inc.
THORN EMI
Technology, Inc.
Telex Computer
Products, Inc.
Trilog, Inc.
3M Data Recording
Products

Universal Data
Systems
Vermont Research
Corp.
Vertex Peripherals
Corp.
Wilson Laboratories,
Inc.
World Storage
Technology
Wangtek
Xylogics, Inc.

Multisystem timer

Timing five independent system, K-series microprocessor-based clock can be set/reset from the external system in 12 field selectable formats. Other features include four-day to six-month battery backup, 0.1-s time reads, and realtime or up/down operation. Bidirectional RS-232, RS-422, and RS-423 ports have parallel and byte-serial output. Time base can be line frequency (50 or 60 Hz) or one of several internal crystal oscillators as well as an external frequency input. **Chrono-Log Corp.**, 2 W Park Rd, Havertown, PA 19083. **Circle 329**

POWER SOURCES & PROTECTION

Battery power at board level

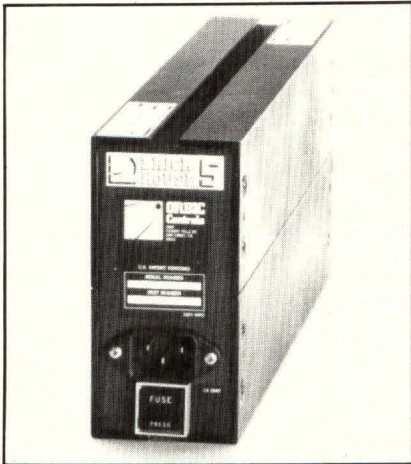

Offering complete independence from line power, BrickHouse 5 provides highly regulated, uninterrupted 5-Vdc power to computers that use all-CMOS digital circuits. Circuitry allows the computer to operate normally through line-power variation, with complete protection against data loss in process or in the memory. The supply works with CMOS on STD bus, Cibus, and COSMAC systems. Input is 90 to 135 Vac, 60 Hz; 100 to 120 Vac, 50 Hz; or 100 to 140 Vac, 400 Hz. Output current range is 1 to 5 A maximum. Prices range from \$250 to \$750. **Orbic Controls**, 5625 Kearny Villa Rd, San Diego, CA 92123. **Circle 330**

Low power switchers

Using MOSFET circuitry, this line has 130 standard models ranging from one to eight outputs in three basic configurations (enclosed, base-mounted, and PC board). The International-MITE series meets safety requirements of IEC 380, VDE 0806, UL 1012, and CSA 22.2. Termination

choices include AMP, Molex, barrier strip, and edge card compatible. Output voltages are 5, 9, 12, 15, and 24 V with output current at 25 A maximum. Pricing for single-output supplies at 50 W is \$84. **LH Research, Inc.**, 14402 Franklin Ave, Tustin, CA 92680. **Circle 331**

MICROPROCESSORS/MICROCOMPUTERS

True 32-bit microprocessor

Monolithic NS32032 CPU is designed for systems that manipulate large data bases at high speeds. Features include full 32-bit internal and external architecture and high level language support, advanced operating systems, and demand paged virtual memory. The external data bus offers increased bandwidth, 32-bit registers, ALU, 32-bit internal data paths, and 32-bit displacements. The initial, 6-MHz version has a 1 MIPS rate and costs \$220 each in 100s. **National Semiconductor Corp.**, 2900 Semiconductor Dr, Santa Clara, CA 95051. **Circle 332**

Processor with 12-Kbyte ROM

The 8-bit TMS70120 chip stores a 12-Kbyte applications program without external ROMs, buffers, or latches. Onchip memory frees up 20 or more of the chip's individual I/O lines for flexible interfacing. In addition, the processor has 128 bytes of RAM and 64 Kbytes of address space. Other features include three prioritized interrupts, an 8-bit timer with programmable 5-bit prescaler, and a stack for control and data storage. Packaged in a 40-pin plastic DIL, the chip is \$11.05 in 10,000s. **Texas Instruments, Semiconductor Group**, PO Box 401560, Dallas, TX 75240. **Circle 333**

Single-board computers at 8 MHz

The master board (SBC 100/8M) and the slave board (SBC 100/8S) offer high throughput via the IEEE 696/S-100 bus. Each board contains a 280H central processor with 64 to 512 Kbytes of RAM, bank selectable in 8-Kbyte segments. Support chips include DART for two serial ports, 4 to 32 Kbytes of EPROM, and an optional math coprocessor. The slave features a 4-Kbyte static RAM buffer for high speed 8- or 16-bit bus transfers. Standard boards (128-Kbyte RAM) are priced at \$995 for the master and at \$895 for the slave. **Sierra Data Sciences, Inc.**, 25700 First St, Westlake, OH 44145. **Circle 334**

acm

SIGGRAPH '84

The
◆ Premier
Computer
Graphics
Conference

◆ 1984 Art, Film and Video Spectaculars

Striking visual presentations of computer graphics excellence. New this year...a curated design arts show plus the first totally computer-generated Omnimax film.

July 23-27, 1984

Minneapolis, Minnesota

- ◆ For information, contact the SIGGRAPH '84 Conference Office
111 East Wacker Drive (A)
Chicago, Illinois 60601
(312) 644-6610

CIRCLE 120

INTERCONNECTION & PACKAGING

Grid array sockets

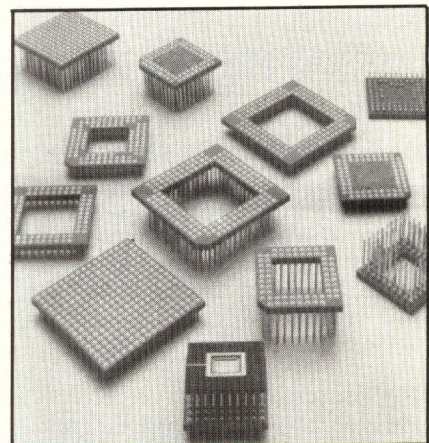

Beat-treated beryllium copper sockets with gold plate come in 25 configurations, solid or open. Outer sleeves are screw machined brass with tin or gold plate. Terminations accept printed circuit or two- or three-level wirewrap. Precision-machined inner contact features four-finger wiping action and low insertion force (80 g per IC pin). Glass-reinforced body is molded thermoplastic polyester. **Mupac Corp.**, 10 Mupac Dr, Brockton, MA 02401. **Circle 335**

Power MOSFETS

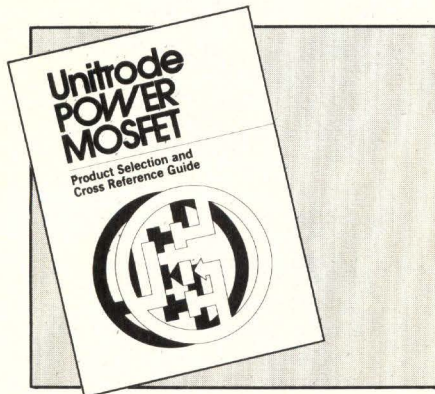

Selection and cross-reference guide separates devices by package, voltage, current rating, and $R_{DS(ON)}$ to expedite match of product to application; over 700 power MOSFETS are listed. **Unitrode Corp.**, Lexington, Mass. **Circle 410**

Applying rms-to-dc theory

Fifty-six page manual considers design and applications of rms-to-dc conversion, examines several circuits, and discusses testing methods for critical parameters. **Analog Devices**, Norwood, Mass. **Circle 411**

Local area networks

Twenty-page booklet reviews the status of different network architectures, technologies, and standards; it also summarizes market characteristics and forecasts growth. **Harris Corp.**, Melbourne, Fla. **Circle 412**

Advanced technology video courses

Brochure describes courses in microprocessors, software engineering, CAD/CAM, and electronic design for engineers, technical managers, and computer professionals. **Integrated Computer Systems**, Santa Monica, Calif. **Circle 413**

Array processors

Individual brochures give précis of Mini-MAP and MAP-6410, touching on applications, system architecture, performance, software, configuration, and support. **CSP Inc.**, Billerica, Mass. **Circle 414**

Diodes and rectifiers

Data book has 232 pages of information, applications, and cross-reference guide on complete line, plus acquired Siemens diode products. **Microsemi Corp.**, Santa Ana, Calif. **Circle 415**

International electrical specs

"World Electricity Supplies and Connectors" tabulates industrial and commercial voltages, as well as plug configurations and types, frequencies, voltage tolerances, and phase distribution diagrams, for most industrial countries; document comes in bound hard copy or floppy disk, or over computer data link. **Pulver Laboratories Inc.**, Boise, Id. **Circle 416**

Linear circuits

Catalog and cross-reference of military ICs, voltage references, dual transistors, op amps, and D-A converters lists second sources for Analog Devices, PMI, Hybrid Systems, Siliconix, Harris, Intersil, Burr-Brown, and National Semiconductor. **Micro Power Systems, Inc.**, Santa Clara, Calif. **Circle 417**

Chip carrier resistors

Product bulletin details TaNFilm LCC network for high density surface mounting in precision industrial or military/aerospace applications; specs, performance and test data, ratings, and ordering information, as well as dimensional drawings and schematics, are included. **TRW Electronic Components Group**, Corpus Christi, Tex. **Circle 418**

Telecommunications trends

Proceedings of the EIA's 1983 telecommunications conference present an overview of market restructuring, and directions in fiber optics, data communications, and subscriber equipment. Request on company letterhead (\$20 postpaid) from: **EIA Telecommunications Group**, 2001 Eye St NW, Washington, DC 20006.

Sockets and terminal carriers

Twenty-page catalog gives specs, footprints, and dimensional cross sections of LIF pin grid arrays, low profile DIPs, high density LSI sockets, DIP adapters, and Peel-a-Way terminal carriers. **Advanced Interconnections**, Warwick, RI. **Circle 419**

Cable-shielding performance

Selection guide defines interference problems, explains FCC regulations on emi, and discusses trade-offs of different cable shield types; 24-page brochure also specifies how well each testing method performs for various types of interference. **Belden**, Geneva, Ill. **Circle 420**

Electronic connectors

Flex-Com IDC system is examined in 65-page guide, which includes complete electrical specs and dimensional drawings for mil-spec headers and sockets, shielded D-subminiatures, and telecommunication-type connectors. **Winchester Electronics**, Oakville, Conn. **Circle 421**

Programmable controller links

Technical report discusses communication between industrial programmable controllers, and suggests alternatives to communication networks; performance criteria are analyzed, and interface to "foreign" devices on a network are discussed. **Reliance Electric Co.**, Stone Mountain, Ga. **Circle 422**

Enhanced position sensing

Four-page application note outlines critical design considerations for a synchro position indicator with built-in microprocessor; five figures illustrate circuits described in text. **ILC Data Device Corp.**, Bohemia, NY. **Circle 423**

Miniaturized switching power

Electrical and environmental specs cover over 50 mil-std encapsulated packages that have ac or dc input modules, with 1 to 10 dc output modules up to 400 W. **Arnold Magnetics Corp.**, Culver City, Calif. **Circle 424**

Analog components

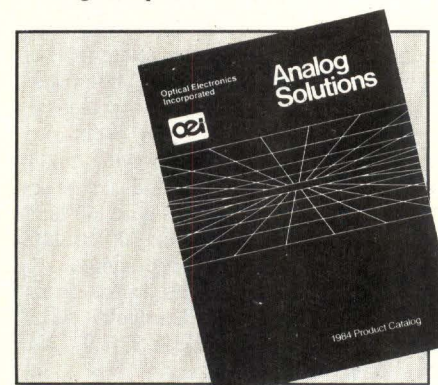

Twenty-six product data sheets and a reference section on the definition and testing of analog specs profile low noise FET amps, fast settling op amps, wide-band op amps, log amps, peak sense and hold modules, and other function modules. **Optical Electronics Inc.**, Tucson, Ariz. **Circle 425**

THE MULTIBUS* - MEGABYTE CONNECTION

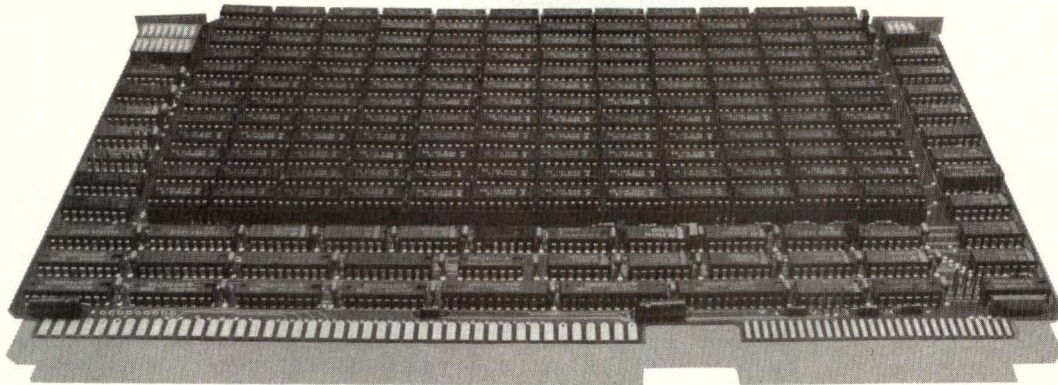

MM-9000D

1M BYTE NOW... 4M BYTES LATER

If you want the highest capacity, best performance, and lowest price add-in memory for your Multibus* system, the MM-9000D is your best buy.

Compatible with Multibus* systems employing 8086, 68000, or Z8000 microprocessors, the MM-9000D provides the flexibility you need for future system upgrades. With 64K DRAMs you can get 1M byte now... when the 256K DRAMs are in production, you can get up to 4M bytes.

The MM-9000D is also a system enhancer because it allows you to extend memory capacity to keep pace with upgrading of your capability. For card slot limited systems, one MM-9000D replaces two 500K byte boards, so you pick up an extra card slot for other uses. Or, if you're power and memory limited, a single 1M byte MM-9000D uses as much power as one 500K byte board.

● FEATURES ●

- 64K DRAM Capacity: 512K, 768K, 1M bytes
- 256K DRAM Capacity: 2M, 3M, 4M bytes
- Cycle/Access Time: 350/240 nsec
- Parity generation and checking with the parity output stored in an Error Status Register whose output can be jumpered to any bus interrupt
- Module selection on 4000_H boundaries in the 16M byte address field
- 24 address bits to address 16M bytes
- 1-year warranty on parts and labor
- Temperature-cycled and burned-in during memory diagnostics

*Trademark of Intel Corp.

NEED OTHER MULTIBUS MEMORIES?

● MICRO MEMORY HAS A COMPLETE LINE ●

PART NO.	CAPACITY	TYPE	PART NO.	CAPACITY	TYPE
MM-8086E	512K-128KB	DRAM, EDC	★MM-8500D	256KB	CMOS, Calendar/Clock
MM-8086D	512K-32KB	DRAM	MM-8086C	64K-16KB	CMOS, Calendar/Clock
MM-8000C	128K-64KB	CMOS	MM-8086	32KB	Core
			★NEW ITEM		

MICRO MEMORY... FIRST IN MICROCOMPUTER MEMORIES

**micro
memory
Inc**

9436 Irondale Avenue
Chatsworth, California 91311

Telephone: (213) 998-0070

CALENDAR

February							March							April							May							June																																	
S	M	T	W	T	F	S	S	M	T	W	T	F	S	S	M	T	W	T	F	S	S	M	T	W	T	F	S	S	M	T	W	T	F	S																											
1	2	3	4	5	6	7	8	9	10	11	12	13	14	15	16	17	18	19	20	21	22	23	24	25	26	27	28	29	30	31	1	2	3	4	5	6	7	8	9	10	11	12	13	14	15	16	17	18	19	20	21	22	23	24	25	26	27	28	29	30	31

CONFERENCES

FEB 14-17—Computer Science Conf and SIGSE Symposium, Franklin Plaza Hotel, Philadelphia, Pa. INFORMATION: Richard Austing, Dept of Computer Science, Univ of Maryland, College Park, MD 20742. Tel: 301/454-2024

FEB 20-22—Office Automation Conf, Los Angeles, Calif. INFORMATION: IEEE Computer Society, PO Box 639, Silver Spring, MD 20901. Tel: 301/589-8142

FEB 21-23—Softcon, Superdome, New Orleans, La. INFORMATION: Peggy Kilburn, Northeast Expositions, 822 Boylston St, Chestnut Hill, MA 02167. Tel: 617/739-2000; 800/343-2222 (outside Mass)

FEB 22-24—ISSCC (IEEE Internat'l Solid State Circuits Conf), San Francisco, Calif. INFORMATION: Lewis Winner, 301 Almeria Ave, Coral Gables, FL 33134. Tel: 305/446-8193

FEB 22-28—Imprinta (Internat'l Congress and Exhibition for Communications Techniques), Dusseldorf, West Germany. INFORMATION: Borman/Williams Inc, 222 Park Ave S, New York, NY 10003. Tel: 212/254-5400

FEB 27-29—Nonimpact Printing Technologies: Database Access Meetings, Sheraton at Fisherman's Wharf, San Francisco, Calif. INFORMATION: Jack Jordan, Advanced Technology Resources Corp, 6256 Pleasant Valley Rd, El Dorado, CA 95623. Tel: 916/626-4104

FEB 28-MAR 1—Comcon/Spring, Cathedral Hill Hotel, San Francisco, Calif. INFORMATION: IEEE Computer Society, PO Box 639, Silver Spring, MD 20901. Tel: 301/589-8142

MAR 12-15—Interface, Las Vegas Convention Ctr, Las Vegas, Nev. INFORMATION: Richard Katzeff, The Interface Group, Inc, 300 First Ave, Needham, MA 02194. Tel: 617/449-6600; 800/325-3330 (outside Mass)

MAR 12-16—Internat'l Conf on Robotics, Atlanta Hilton, Atlanta, Ga. INFORMATION: IEEE Computer Society, PO Box 639, Silver Spring, MD 20901. Tel: 301/589-8142

MAR 19-21—Phoenix Conf on Computers and Communications, Phoenix Hilton, Phoenix, Ariz. INFORMATION: David Gretton, Digital Equipment Corp, 2500 W Union Hills Dr, Phoenix, AZ 85027. Tel: 602/869-5273

MAR 25-28—Numerical Control Society Technical Conf and Expo, Queen Mary, Long Beach, Calif. INFORMATION: Lisa Schultz, Numerical Control Society, 111 E Wacker Dr, Suite 600, Chicago, IL 60601. Tel: 312/644-6610

MAR 26-30—Internat'l Conf on Software Engineering, Orlando, Fla. INFORMATION: IEEE Computer Society, PO Box 639, Silver Spring, MD 20901. Tel: 301/589-8142

APR 2-5—Test & Measurement World Expo, Brooks Hall, San Francisco, Calif. INFORMATION: Meg Bowen, Interfield Publishing Co, 215 Brighton Ave, Boston, MA 02134. Tel: 617/254-1445

APR 3-5—Internat'l Reliability Physics Symposium, Caesars Palace, Las Vegas, Nev. INFORMATION: George Ebel, Singer Co, 150 Totowa Rd, Wayne, NJ 07470. Tel: 201/785-6656

APR 4-11—Hannover Fair, Hannover, West Germany. INFORMATION: Delia Assocs, PO Box 338, Whitehouse, NJ 08888. Tel: 201/534-9044; 800/526-5978 (outside NJ)

APR 10-12—Infocom, Cathedral Hill Hotel, San Francisco, Calif. INFORMATION: IEEE Computer Society, PO Box 639, Silver Spring, MD 20901. Tel: 301/589-8142

APR 18-20—Optical Data Storage, Monterey Convention Ctr, Monterey, Calif. INFORMATION: Optical Society of America, 1816 Jefferson Pl NW, Washington, DC 20036. Tel: 202/223-8130

APR 24-27—Compdec (Internat'l Conf on Data Engineering), Bonaventure Hotel, Los Angeles, Calif. INFORMATION: IEEE Computer Society, PO Box 639, Silver Spring, MD 20901. Tel: 301/589-8142

APR 30-MAY 2—Workshop on Computer Vision, Hilton Hotel, Annapolis, Md. INFORMATION: IEEE Computer Society, PO Box 639, Silver Spring, MD 20901. Tel: 301/589-8142

Announcements intended for publication in this department of *Computer Design* must be received at least three months prior to the date of the event. To ensure proper timely coverage of major events, material should be received six months in advance. Programs and dates are subject to last minute changes.

MAY 13-17—Computer Graphics, Anaheim Convention Ctr, Anaheim, Calif. INFORMATION: National Computer Graphics Assoc, 8401 Arlington Blvd, Fairfax, VA 22031. Tel: 703/698-9600

MAY 14-17—Internat'l Conf on Communications, Congresscentrum Rai, Amsterdam, The Netherlands. INFORMATION: K. Teer, Philips Research Lab, 5600 MD Eindhoven, The Netherlands.

MAY 14-17—Internat'l Conf on Distributed Computing, Cathedral Hill Hotel, San Francisco, Calif. INFORMATION: IEEE Computer Society, PO Box 639, Silver Spring, MD 20901. Tel: 301/589-8142

MAY 15-17—Electro, Bayside Exposition Ctr and Hynes Auditorium, Boston, Mass. INFORMATION: Kent Keller, Electronic Conventions, Inc, 8110 Airport Blvd, Los Angeles, CA 90045. Tel: 213/772-2965

MAY 15-17—Mini/Micro-Northeast, Hynes Auditorium, Boston, Mass. INFORMATION: Kent Keller, Electronic Conventions, Inc, 8110 Airport Blvd, Los Angeles, CA 90045. Tel: 213/772-2965

JUNE 4-8—SID (Society for Information Display Internat'l Symposium), San Francisco Hilton, San Francisco, Calif. INFORMATION: Lewis Winner, 301 Almeria Ave, Coral Gables, FL 33134. Tel: 305/446-8193

JUNE 5-7—Internat'l Symposium on Computer Architecture, Rackham Building, Ann Arbor, Mich. INFORMATION: Keki Irani, ECE Dept, Univ of Michigan, Ann Arbor, MI 48109. Tel: 313/764-8517

JUNE 5-7—Symposium on Mass Storage Systems, Marriott Mark Resort, Vail, Colo. INFORMATION: Bernard O'Lear, NCAR, PO Box 3000, Boulder, CO 80307. Tel: 303/494-5151

JUNE 6-8—Communications Architectures and Protocols, Montreal, Canada. INFORMATION: Rebecca Hutchings, Honeywell/FSD, 7900 Westpark Dr, McLean, VA 22102. Tel: 703/827-3982

JUNE 19-22—Internat'l Symposium on Fault Tolerant Computing, Hyatt Orlando, Orlando, Fla. INFORMATION: Richard Sedmak, Sperry Univac, PO Box 500, MS C1SW12, Blue Bell, PA 19404. Tel: 215/542-3638

JUNE 24-27—Design Automation Conf, Albuquerque Convention Ctr, Albuquerque, NM. INFORMATION: IEEE Computer Society, PO Box 639, Silver Spring, MD 20901. Tel: 301/589-8142

Designer's Bookcase

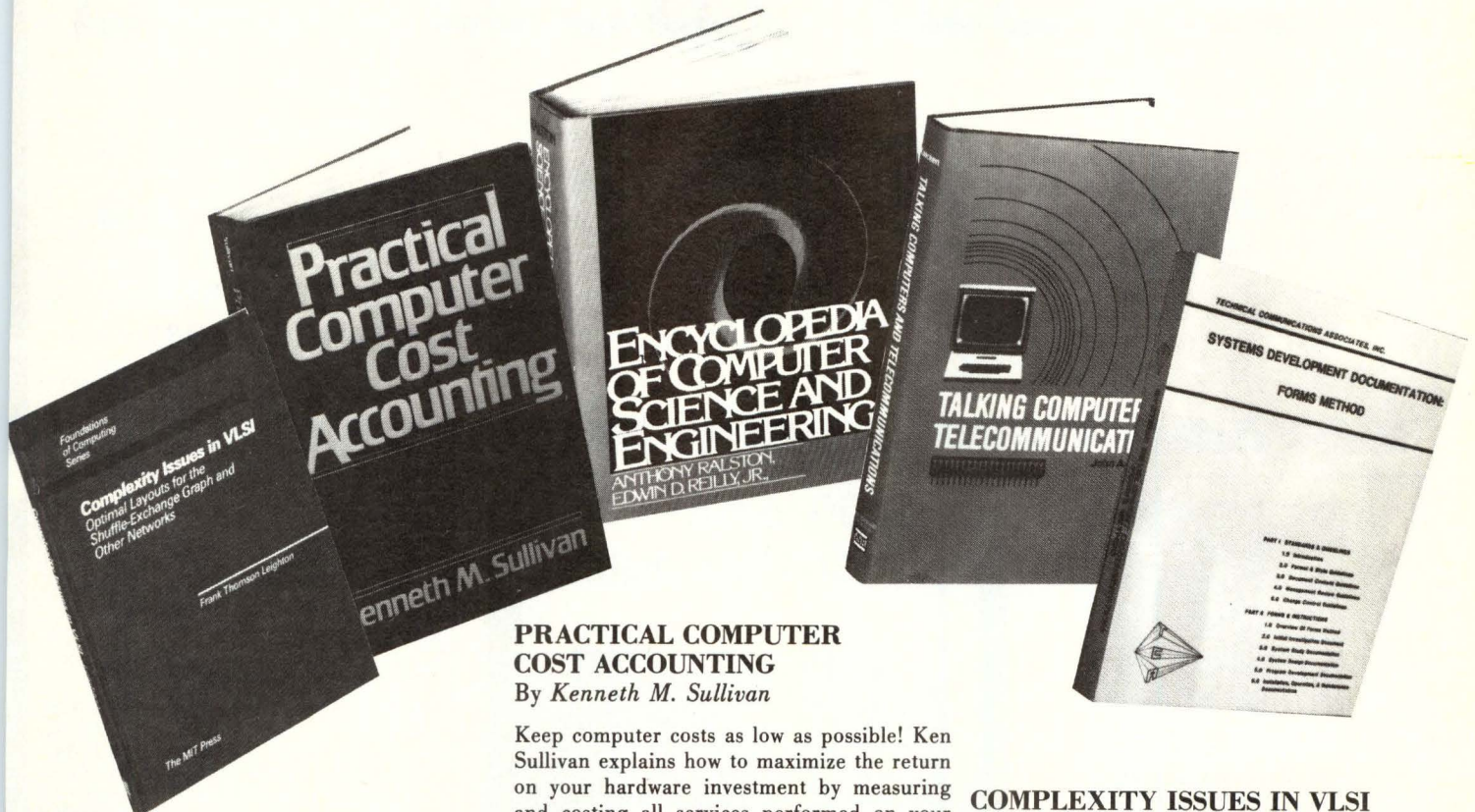

ENCYCLOPEDIA OF COMPUTER SCIENCE AND ENGINEERING

Edited by *Anthony Ralston*

This one-volume library of technical data gives you a storehouse of information in areas ranging from computer systems to the mathematics of computers, modern computer applications, and much more. Its fully revised chapters provide state-of-the-art data on such topics as artificial intelligence, digital computer systems, image processing, and data base technology. "Impressive, comprehensive, well-done."

Datamation \$87.50

Circle 455

SYSTEMS DEVELOPMENT DOCUMENTATION: Forms method

By *Technical Communications Associates, Inc.*

This 430 page publication presents a series of simple procedures for preparing documentation that evolve around the use of pre-structured forms that record the results of the task performed during the system development cycle. The forms cover a wide range of system development functions and are formatted to present all types of documentation. Also suggested in this publication are standards for documentation preparation.

\$69.50

Circle 456

PRACTICAL COMPUTER COST ACCOUNTING

By *Kenneth M. Sullivan*

Keep computer costs as low as possible! Ken Sullivan explains how to maximize the return on your hardware investment by measuring and costing all services performed on your computer system. He shows you how to set up cost accounting systems for centralized, decentralized, and distributed processing systems and how to use accounting data for managing computer costs.

\$24.95

Circle 457

HOW TO ORDER:

15-DAY FREE EXAMINATION (U.S. AND CANADA ONLY)

Simply circle the appropriate number(s) on the Reader Inquiry Card at the back of this magazine.

Your book will be sent to you for your **15-day free trial**. If you are satisfied, keep the book and an invoice will follow. Otherwise return the book by the end of the 15-day period, and owe nothing.

COMPLEXITY ISSUES IN VLSI

by *Frank Thomson Leighton*

First in a new series called "Foundations of Computing". This book solves several mathematical problems in the areas of VLSI and parallel computation. In particular, it describes optimal layouts for the shuffle-exchange graph, one of the best known networks for parallel computation. Researchers in the fields of VLSI, parallel computation, and graph theory will find this study of particular value; it is also accessible to anyone with an elementary knowledge of mathematics and computer science.

MIT PRESS \$19.95

Circle 458

TALKING COMPUTERS AND TELECOMMUNICATIONS

By *John A. Kuecken*

Turn here for the latest methods on speech digitization and reproduction. *Talking Computers and Telecommunications* covers fundamental engineering requirements for producing intelligible synthesized speech and shows how to produce computer-synthesized speech using Moser synthesis and Linear Predictive Coding techniques. You find invaluable data on telephony, tone detectors, the DTMF detector, and much more.

\$26.50

Circle 459

COMPUTER DESIGN'S

SYSTEM SHOWCASE

CIRCLE 475

for rates and information

CALL...

Shirley Lessard
(800)225-0556
in MA 486-9501

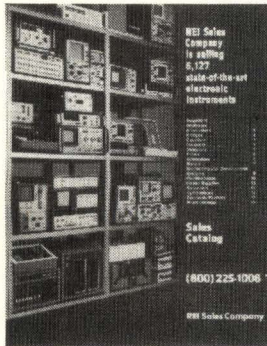

LIKE NEW PRODUCTS

For free catalog,
phone toll-free (800)225-1008
In Massachusetts (617)938-0900
GENSTAR REI SALES COMPANY
6307 DeSoto Ave, Suite J,
Woodland Hills, CA 91367.

CIRCLE 476

6800/6809 Micro Modules

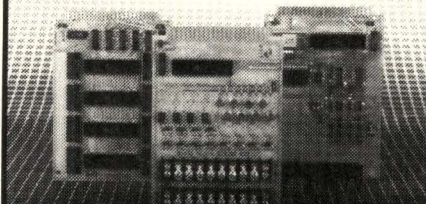

OEM 6800/6809 MICROCOMPUTER MODULES for dedicated control and monitoring. Interfaces for sensors, transducers, analog signals, solenoids, relays, lamps, pumps, motors, keyboards, displays, IEEE-488, serial I/O, floppy disks.



Wintek, Corp.
1801 South Street
Lafayette, IN 47904
317-742-8428

CIRCLE 477

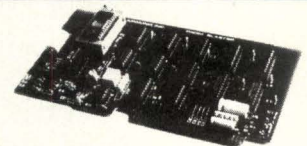

APPARAT PROM BLASTER FOR THE TRS-80, APPLE OR IBM PC

Apparat's Prom Blasting system (A.P.B.) will program most 24-pin EPROM's including the Motorola 64K device (68764). The package comes complete with interface card, a complete set of personality modules, software on disk and a detailed instruction manual. The cost of the A.P.B. system is \$119 (\$129 for the IBM). TRS-80 versions may require the Apparat Bus-Extender at \$69.95, or a user-supplied power supply and cable.

For details on the A.P.B. system, contact **APPARAT, INC.**, located at 4401 S Tamarac Parkway, Denver, Colorado 80237, or call Apparat's technical/service department at 303-741-1778.

CIRCLE 478

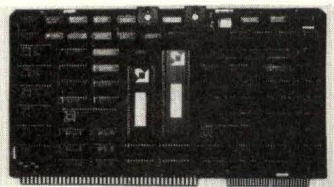

THE SINGLE BOARD ARRAY PROCESSOR

FAST—up to 8 million operations per sec.
VERSATILE—fixed or floating point math, real or complex numbers, Std. Routines or develop your own. ACCESSIBLE—memory mapped, looks like RAM to host. INEXPENSIVE—\$4,250.00. AVAILABLE BUSES—Multibus*, IBM PC—others in work. CONTACT: **MARINCO, INC.**, 3878 Ruffin Rd, San Diego, CA 92123. Tel: (619) 268-4814, TLX: 69-7901

MARINCO COMPUTER PRODUCTS

*Trademark of Intel

CIRCLE 479

Personal computer users:

FOR FREE ACCESS TO A BETTER JOB CALL CLEO.

(213) 618-8800 (408) 294-2000
(415) 482-1550 (714) 476-8800
(619) 224-8800

Standard ASCII code
Access assistance:
(213) 618-1525



Computer Listings of Employment Opportunities

CIRCLE 480

Wire-Wrap® & Multiwire® Software

Whip your designs
into shape with
WIREMASTER



Never do another design by hand! Your computer and **Wiremaster** will quickly and accurately convert your schematic into wire lists, net maps, parts lists, checklists, and plots (optional) to give you total control. Handles ECL and twisted pair wiring. Versions available for NC machines. Runs on IBM-PC, VAX, CP/M, MSDOS and Unix Computers.

No-risk demo disk available. Call or write for details.

AFTERTHOUGHT ENGINEERING
7266 Courtney Dr., San Diego, CA 92111
(619) 279-2868

CIRCLE 481

Single Chip μ Computer Development Kits \$325

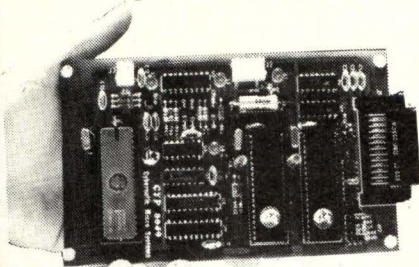

Use your IBM PC or XT to cross-Assemble code using standard Intel mnemonics for the 8048/49, 8051 or the TMS 7000 MicroComputer chips, then download via RS-232 to the EPROM Programmer Boards.

CROSS ASSEMBLER	PROGRAMMER	BOTH
CYS-8049 \$195	CYP-8049* \$195	\$325
CYS-8051 \$195	CYP-8051* \$195	\$325
CYS-7000 \$195	(Avail soon for EEPROM)	

*requires assembly and power supply



Cybernetic Micro Systems
Box 3000 • San Gregorio, California 94074 U.S.A.
(415) 726-0000 • Telex T-1435 Attn: Cybernetics

CIRCLE 482

C76 HYBRID I/O INTERFACE SYSTEM

C76 SERIES SOLID STATE DIP I/O™
Modules are designed for use in computerized control systems for noise-free isolated interfacing of computer logic elements to harsh industrial environments. Modules employ custom microcircuits in a TO-116 DIP. Low "Per-point" cost. Meets VDE spacing and voltage requirements. Features CMOS and TTL compatibility, optical isolation, high noise immunity and an ENABLE function on input modules. \$8.70 to \$9.65 (depending on function) at production quantities. **TELEDYNE RELAYS**, 12525 Daphne Ave. Hawthorne, CA 90250. Tel: (213) 777-0077

CIRCLE 483

WHY YOU SHOULD MAKE A CORPORATE CONTRIBUTION TO THE AD COUNCIL

The Advertising Council is the biggest advertiser in the world. Last year, with the cooperation of all media, the Council placed almost six hundred million dollars of public service advertising. Yet its total operating expense budget was only \$1,147,000 which makes its advertising programs one of America's greatest bargains... for every \$1 cash outlay the Council is generating over \$600 of advertising.

U.S. business and associated groups contributed the dollars the Ad Council needs to create and manage this remarkable program. Advertisers, advertising agencies, and the media contributed the space and time.

Your company can play a role. If you believe in supporting public service efforts to help meet the challenges which face our nation today, then your company can do as many hundreds of others—large and small—have done. You can make a tax-deductible contribution to the Advertising Council.

At the very least you can, quite easily, find out more about how the Council works and what it does. Simply write to: Robert P. Keim, President, The Advertising Council, Inc., 825 Third Avenue, New York, New York 10022.

Ad Council A Public Service of This Magazine & The Advertising Council.

The cost of preparation of this advertisement was paid for by the American Business Press, the association of specialized business publications. This space was donated by this magazine.

128K RAM/512K EPROM! THE MEMORIZER S-100 based

- Accepts any 1K x 8 to 32K x 8 part, RAM or EPROM
- Extended memory addressing bank select
- Two banks of eight 28 Pin sites (JEDEC)
- Independent wait states
- Mix RAM or ROM in the same bank

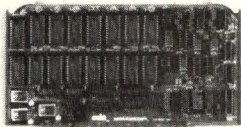

ADS Ackerman Digital Systems
216 West Stone Ct., Villa Park, IL 60181
(312) 530-8992

CIRCLE 484

EPROM EMULATOR

The Romulator™ emulates 2716, 27C16, 87C32, 2764, and 27C64 EPROMs using a technique that allows a check of a ROM-based program without burning an EPROM. It will not latch-up CMOS systems, operates at 19,200 baud using an RS-232 link, and has disk file load and write capability. Self contained, with power supply, and software for CP/M or PC DOS based systems—\$550, Qty 1. **ONSET COMPUTER CORP.**, 119 Main St, No Falmouth, MA 02556. Tel: (617) 563-2267, TLX 469915

CIRCLE 485

COMPUTER DESIGN SUPER DECKS

- Now 90,000 circulation - 75,000 qualified Computer Design U.S. subscribers, plus 15,000 pass-along engineer inquirers
- Six mailings in '84 - January, March, May, July, September and November
- Less than a penny per card for 6 time users.
- Rates start at \$1195.00 and go down with frequency.
- Closing 21st of previous month of mailing.

Contact Shirley Lessard, Computer Design, 119 Russell St, Littleton, MA 01460. Tel: Toll Free (800) 225-0556.

CIRCLE 486

Serial ← ■■■■■■■■ → Parallel

NEW!

PRINTERS!
PLOTTERS!
PUNCHES!
ROBOTS!

Convert What You Have To What You Want!

- RS232 Serial
- 8 Baud Rates
- Latched Outputs
- Centronics Parallel Handshake Signals
- Compact 3/4" x 4 1/4" x 1 1/4"

No longer will your peripheral choices be limited by the type of port you have available! Our new High Performance 700 Series Converters provide the missing link. Based on the latest in CMOS technology, these units feature full baud rate selection to 19.2K, with handshake signals to maximize transfer efficiency. Detailed documentation allows simplified installation. Order the Model 770 (Ser/Par) or Model 775 (Par/Ser) Today!

only \$89.95

Buffer Products Coming Soon!

Engineering Specialties
1501-B Pine Street
Post Office Box 2233
Oxnard, California 93030

CALL (805) 487-1665 or 487-1666
For FAST Delivery

Connector Option \$10.00
CA Residents 6% tax
UPS Shipping \$3.00

CIRCLE 487

AD INDEX

Able Computer63	Concord Data Systems192
<i>Cochrane Chase, Livingston & Co Inc</i>	<i>Impact Advertising</i>
Ackerman Digital251	Conrac Corp166, 167
ADE Corp226	Control Data Corp99
<i>Floudaras Associates Inc</i>	<i>E H Brown Advertising Agency Inc</i>
Advanced Micro Devices18, 19	Copley Press/CLEO250
<i>Keyel/Donna/Pearlstein</i>	<i>McCann-Erickson Inc</i>
Afterthought Engineering250	Cybernetic Micro Systems251
Airpax Corp195	
<i>Lewis, Gilman & Kynett Inc</i>	
Alpha Wire Corp65	Dataram CorpC3, 5
Alps Electric (USA)34, 35	<i>Louis Zimmer Communications Inc</i>
<i>Industrial Marketing Associates</i>	Data Systems Design112
AMP232, 233	<i>Tycer • Fultz • Bellack</i>
<i>Lewis, Gilman & Kynett Inc</i>	Digi-Data Corp60
Apparat250	<i>Business Marketing Inc</i>
Applied Circuit Technology89	Digital Engineering209
<i>Cube 4</i>	Distributed Computer Systems115
Applied Micro Circuits Co170	<i>Media Concepts</i>
<i>Manning & Associates</i>	Distributed Logic Corp204
AST Research41	<i>Ron Jenner & Co.</i>
Atasi Corp38, 39	DMA Systems220, 221
<i>Lone, Lord & Schon</i>	<i>Jansen Associates Inc</i>
Auerbach Publishers253	Dolch Logic Instruments148
<i>Royer Graphics</i>	<i>Murphy Advertising</i>
	Dual Systems228, 229
Belting Industries44	<i>Imahara & Keep</i>
<i>Keyes Martin</i>	
Bunker Ramo Corp235	Emulex Corp202, 203
<i>James A. Ford Advertising</i>	<i>Jansen Associates Inc</i>
Burr-Brown Corp185	Emulogic212, 213
<i>Curt Anderson Advertising</i>	<i>Giardini/Russell Inc</i>
	Engineering Specialties251
Cadmus Computer161	<i>Darryl Lloyd Advertising</i>
<i>Emerson Lane Fortuna Inc</i>	Epson America239
CalComp165	<i>Darryl Lloyd Advertising</i>
<i>Jansen Associates Inc</i>	
Callan Data Systems173	First Systems107
<i>Abert Newhoff & Burr Inc</i>	<i>Nathanson Advertising Inc</i>
Canon USA101	John Fluke Mfg Co Inc69, 157
<i>Zam Kirshner & Geller</i>	Fujitsu America46, 47
Charles River Data Systems200, 201	<i>Shaffer/MacGill & Associates, Inc</i>
Cherry Electrical Products33	Fujitsu America131
<i>Kolb Bauman Advertising, Inc</i>	<i>Ebey, Utley, van Bronkhorst</i>
Chrislin Industries227	Fujitsu America58, 59
Cipher Data Products78, 79	<i>Peter Wong Associates</i>
<i>Richter & Carr</i>	FutureNetC4
Clifton Precision30	<i>Courtney/Wilson Advertising</i>
<i>Larwin Livers Associated Inc.</i>	
ComPower223	Genicom144
<i>Power Products Promotions</i>	<i>Cabell Eanes Advertising</i>
Computer Automation56, 57	Genstar REI250
<i>Cochrane Chase Livingston & Co Inc</i>	<i>Warr Foote & Rose</i>
Computrol14	Global Specialties Corp117
<i>RFD Associates</i>	<i>RPR Advertising</i>

Gould.....	45
<i>Group 3hree Advertising</i>	
Gould.....	140, 141
<i>Tycer • Fultz • Bellack</i>	
GTCO Corp.....	187
<i>Business Marketing Inc</i>	
Guardian.....	253
<i>Ron Jenner & Co.</i>	
Heinemann Electric Co.....	10
<i>Thomas R Sundheim Inc</i>	
Heurikon Corp.....	234
<i>Gutzman McFee McLaughlin & May</i>	
Hewlett Packard.....	36, 37
<i>Tallant/Yates Advertising Inc</i>	
Hilevel Technology.....	153
<i>Galusha & Associates</i>	
Hitachi America Ltd.....	155
<i>Cooper-Cameron Inc</i>	
Hitachi America Ltd.....	2
<i>Yamaguchi Advertising</i>	
Houston Instrument.....	73
<i>Cooley & Shillinglaw</i>	
Hughes Aircraft Co.....	255
<i>Bernard Hodes Advertising</i>	
Huntsville Microsystems.....	52
<i>KSA Associates Inc</i>	
IBIS Systems.....	222
<i>TCI Advertising</i>	
Identicon, Div of Vertex.....	231
Inmac.....	136
<i>Humpal, Leftwich & Sinn, Inc</i>	
Inmos.....	12, 13, 80
<i>Tallant/Yates Advertising Inc</i>	
Intech.....	163
Intel.....	124, 125, 133, 190, 191
<i>Chiat/Day/Hoefer Inc Advertising</i>	
Interphase.....	96
Invitational Computer Conference—US.....	244
<i>B J Johnson & Associates</i>	
Iomega Corp.....	159
<i>Offield & Brower</i>	
Kennedy Co.....	1
<i>R L Thompson Advertising</i>	
Key Tronic.....	16
<i>Elgee Co</i>	
Kontron Electronics.....	214, 215
Leasametric.....	75
<i>Doyle Dane Bernbach/S.F.</i>	
Lexidata Corp.....	146
<i>Humphrey Browning & MacDougall Inc</i>	
Liberty Electronics.....	90, 91

ATTENTION:
MICRO SOFTWARE
SUPPLIERS/DEVELOPERS

Do you currently offer engineering or scientific software application packages for the IBM PC or XT?

If so, Auerbach is providing you with the opportunity to have your packages considered for inclusion in a new publication . . . FREE.

If your engineering or scientific software packages are on the market today and run on the IBM PC or XT, you may qualify . . . contact us immediately!

Submit your company name, contact, and telephone number, along with the name(s) of your software package(s) to:

Software Editor
 Auerbach Publishers Inc.
 6560 N. Park Drive
 Pennsauken, NJ 08109

Or call:

(800) 257-8162, Ext. 230
 (In NJ, (609) 662-2070, Ext. 230)



Auerbach has been a leading publisher of computer information for over 25 years.

CIRCLE 131

50% MORE I/O

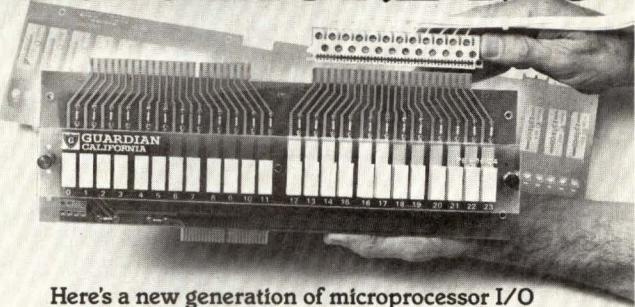

Here's a new generation of microprocessor I/O modules and mounting boards. They'll let you fit 3 in the space of 2. That's a 50% gain. And for about what the bulky older units cost. Here's how.

The AC/DC module size has been reduced. Without reducing reliability. And the 1/3 thinner modules replace conventional units . . . without tools.

The new Guardian mounting board shown accommodates 24 I/Os in the space and mounting holes occupied by competitive PB16s. A 12 I/O model replaces the older PB8s.

Other important features include ■ card edge connectors that permit "connectorizing" with screw terminals for easier installation/removal ■ individually accessible fuses ■ ample erasable legend areas.

Contact your local distributor or the factory for new generation microprocessor I/O . . . and get 50% more.



GUARDIAN®
CALIFORNIA

GUARDIAN ELECTRIC MANUFACTURING COMPANY OF CALIFORNIA INC.
 16100 South Figueroa Street, Gardena, CA 90248 • Phone (213) 532-3092 • TWX 910-344-7381

CIRCLE 132

COMPUTER DESIGN/January 1984 253

AD INDEX

Marinco Computer Products250	RTCS211
<i>The Torrey Group</i>	
Masscomp207	Scientific Micro Systems15
<i>Rossin Greenberg Seronick & Hill Inc</i>	Seagate Technology94, 95
Matra Design Systems151	<i>Lutat, Battey Associates</i>
<i>Wilson Communications</i>	Seattle Computer224
Maxell Corp119	<i>Floathe & Associates Inc</i>
<i>A C & R Advertising Inc</i>	Shugart Corp20, 21
Measurement Systems235	<i>Chiat/Day/Hoefer Inc Advertising</i>
<i>Richard Lawrence & Associates</i>	Siggraph '84241, 243, 245
MegaTape48	Signetics53-55
<i>Nathanson Advertising Inc</i>	<i>Wilton, Coombs & Colnett Inc Advertising</i>
Megatek CorpC2	Silicon Systems42, 43
<i>LeAnce, Herbert & Bowers</i>	<i>JMR Advertising</i>
Metheus Corp50	Sonnenschein Batteries22
<i>Jack Ramsey Advertising Inc</i>	<i>Kornhauser & Calene, Inc</i>
Micro Memory247	Sony Video Products142, 143
Microtek216	<i>Waring & LaRosa</i>
<i>Darryl Lloyd Advertising</i>	South Carolina Development Bd164
Minor Rubber Co242	<i>Cook Ruf & Associates</i>
<i>C R Associates</i>	Standard Microsystems49, 51
Motorola Semiconductor Products122, 123	<i>Greenstone & Rabasca Advertising Inc</i>
<i>Comm Ad Advertising</i>	Step Engineering129
Multi Solutions126	
<i>G&C Advertising</i>	Tandberg Data Storage Div236, 237
National Semiconductor Corp23-27	<i>Lenac, Warford, Stone, Inc</i>
<i>Foote Cone & Belding/Honig</i>	Tandon Corp76, 77
NCR Corp28, 29	<i>Reiser Williams DeYong/C&W</i>
<i>Reiser Williams DeYong</i>	Tektronix120, 121
NEC America178, 179	<i>Tektronix Advertising</i>
<i>Ingalls Associates Inc</i>	Teledyne Relays251
NEC Electronics USA92, 93	<i>Michelson Advertising</i>
<i>Tycer • Fultz • Bellack</i>	TeleVideo180, 181
Northrop Corp256	<i>Grey Advertising Inc</i>
<i>Jordan/Tamraz/Caruso Advertising</i>	Thorn EMI Datatech189
Northwest Digital Systems108	<i>Marsteller Ltd</i>
	3M Co138, 139
Odetics230	<i>BBDO Inc</i>
Onset Computer Corp251	Verbatim Datalife71
	<i>Battenberg, Fillhardt & Wright, Inc</i>
Panasonic105, 135	Versitron Inc177
<i>Sommer Agency</i>	<i>Pallace Inc</i>
Plessey Microsystems109	
<i>Lindhult & Jones, Inc.</i>	Wintek250
Qantex85	Wilson Laboratories87
<i>NOAT Advertising Co</i>	<i>Sylvester Advertising</i>
Quantum110, 111	Wyse Technology137, 225
<i>Battenberg, Fillhardt & Wright, Inc</i>	<i>Ebey, Utley, van Bronkhorst</i>
Relational Memory Systems182	
<i>Zhivago Advertising</i>	ZAX Corp168, 169
Rosscomp67	<i>Sales Management International</i>
<i>LeAnce, Herbert & Bowers</i>	Zilog8, 9
	<i>Pinné, Garvin, Herbers & Hock Inc</i>

HUGHES

THE PEOPLE BEHIND
ELECTRO-OPTICS



CREATE NEW VISIONS

From the demonstration of the first working laser to today's VHSIC. The people of Hughes Electro-Optical & Data Systems Group are talented... determined... proud. They challenge themselves at the leading edge of technology. In an environment that both stimulates and actively supports a diversity of technical contributions. Resourceful science... coupled with creative engineering. Hughes people have made it an art.

The people of Electro-Optical & Data Systems Group are now operating from their new, ultra-modern facility... a virtual city of technology. It's one of the largest and most sophisticated of its kind. On-site recreational facilities provide a healthful work environment. It has

consolidated both engineering and manufacturing functions into one location, enhancing essential communications, while contributing significantly to all time sales milestones.

At Hughes, there is a stimulating relationship between the people and their work. Between the individual and the team... the team and the group... the group and the company. A relationship that provides opportunity for substantial individual contribution. That's what Hughes Electro-Optical & Data Systems Group is all about. People. People with vision and dedication. People participating in extraordinary ways.

People like you.

Current openings: • Image Processing Engineers

• Component Application Engineers • Circuit Design Engineers • Test Engineers • Material/Process Application Engineers • Thermal Systems Engineers • Electro-Optical Systems Engineers • Failure Analysis Engineers • Sensor Design Engineers • Semiconductor Engineers • Optic Design Engineers • Laser Engineers

Send your resume to:
Hughes Electro-Optical & Data Systems, P.O. Box 913,
Dept. DC-1, El Segundo,
CA 90245.

Creating a new world with electronics

HUGHES

HUGHES AIRCRAFT COMPANY

Proof of U.S. Citizenship Required.
Equal Opportunity Employer.

ELECTRO-OPTICAL AND DATA SYSTEMS GROUP

ECM: The Core of America's Defense

NORTHROP
MAKING ADVANCED
TECHNOLOGY WORK

Northrop DSD Electronic Countermeasures Technology is the heartbeat of today's national defense. It quickens to the challenge and represents our ability to out-think . . . out-manuever . . . and out-calculate rapidly.

Experienced professionals can join our opportunities and work along with an outstanding team of R&D engineers in an exciting, technologically progressive and advanced product design and development environment.

Northrop DSD. The Core of advanced ECM technology. The place for a new career.

SOFTWARE ENGINEERS

Positions are available for engineers with BSCS or BSEE degrees, or equivalent, and experience in the following:

- **ENGINEERING COMPUTER CENTER:** Will develop, test, integrate and document system software programs for ATE. Experience using Fortran 77 and PASCAL required; exposure to compilers and operating systems preferred. Background with HP 1000 and knowledge of digital hardware desirable.
- **PROJECT DESIGN ENGINEERING:** Develop real time process control software for airborne ECM system applications. Will be involved in coding, test and system integration program phases. Minimum of 2+ years experience in Assembly and Fortran programming; familiarity with Radar ECM or Avionics desirable.

Northrop offers a highly competitive salary schedule and comprehensive benefits portfolio. Candidates should forward resume with salary requirements to: **P. SCHMITZ, Professional Employment.**

NORTHROP CORPORATION DEFENSE SYSTEMS DIVISION

500 Hicks Road, Rolling Meadows, IL 60008

We are an equal opportunity employer and encourage minorities, females, veterans and the handicapped to apply. U.S. Citizenship Required.



SALES OFFICES

Home Office

119 Russell St.
Littleton, MA 01460
(617) 486-9501
Marketing Director
Robert Billhimer
Ad Traffic Coordinator
Ginger Rhoads
**Systems Showcase/
Postcard Deck**
Shirley Lessard
List Rental
Robert Dromgoole
Classified/Recruitment
Shirley Lessard

New England & Upstate New York

Regional Manager

Barbara Arnold
119 Russell St.
Littleton, MA 01460
(617) 486-9501

Mid-Atlantic/Southeast

Dick Busch, Inc.

Richard V. Busch
6 Douglass Dr., R.D. #4
Princeton, N.J. 08540
(201) 329-2424
Eleanor Angone
74 Brookline Ave.
E. Atlantic Beach, NY 11561
(516) 432-1955

Midwest & Colorado

Berry Conner Associates

Berry Conner, Jr.
88 West Schiller St., Suite 2208
Chicago, IL 60610
(312) 266-0008

Western States & Texas

Buckley/Boris Assoc., Inc.

Tom Boris
John Sabo
Terry Buckley
2082 SE Bristol, Suite 216
Santa Ana, CA 92707
(714) 957-2552
Terry Buckley
M. Patricia Shay
P.O. Box 278
Campbell, CA 95009
(408) 866-8735

International

International Sales Manager

Eric Jeter
1200 Post Oak Blvd.
Houston, TX 77056
(713) 621-9720

U.K. and Scandinavia

David Betham-Rogers
David M. Levitt
tel: 222-0744
12 Caxton Street
Westminster, London SW1H 0QS

France, Belgium and S. Switzerland

Daniel R. Bernard—354-5535
Prominter, 247 rue Saint Jacques
75005 Paris
telex: 250303 Public Paris
(Pour Prominter no. 9102)

Holland, Austria, W. Germany, Switzerland & Eastern Europe

Heinz Gorgens—0 21 53/66 33
Dr. Dieter Jaspers
4054 Nettetal 1
West Germany, Krugerpfad 1

*(TM)

DATARAM OFFERS MORE DATA GENERAL COMPATIBLE MEMORY THAN ANYONE. FOR GOOD REASONS.

Dataram has been delivering Data General-compatible memory since 1974, today offering the industry's most extensive range of such products — from ADD-IN memory to BULK MEMORY disc emulation systems.

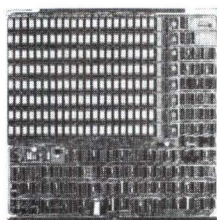

AND STILL GROWING. We've just introduced a versatile, highly reliable 1.0 MB ADD-IN for Data General's NOVA 4 and ECLIPSE S/140 minicomputers, which puts it at the head of an already impressive class of ADD-INS:

DATARAM ADD-IN	MAXIMUM CAPACITY	DATA GENERAL MINI
DR-240 (semi)	1.0 MB	NOVA 4, ECLIPSE S/140
DR-225 (semi)	1.0 MB	ECLIPSE S/130 AND OTHERS
DR-123S (semi)	256 KB	NOVA 3
DR-123 (core)	32 KB	NOVA 3
DR-124 (core)	32 KB	NOVA 2
DR-1200 (core)	32 KB	NOVA 1200

ADDING MORE THAN MEMORY. And we don't stop with ADD-IN memory products — we can expand the capability of your Data General mini with a family of BULK MEMORY systems. Performance-proven systems that emulate Data General fixed head disc systems — but add the important advantages of solid-state speed and reliability. Making it ideal for disc swapping and more.

MORE THAN COMPATIBLE. Many of Dataram's products incorporate enhancements not available from comparable Data General products. For example, our 1.0 MB NOVA 4 compatible ADD-IN provides an extra ECC bit (giving you 6 ECC, rather than Data General's 5 ECC bits), transparent to the host mini, which allows full double-bit error detection.

AND FOR LESS COST THAN YOU'D EXPECT for highly reliable, proven memory products.

Any way you look at it, Dataram can do a lot in general to meet your requirements for Data General memory. But be specific — give us a call today to discuss your requirement.

ECLIPSE, NOVA, AND NOVADISC are registered trademarks of Data General Corporation.

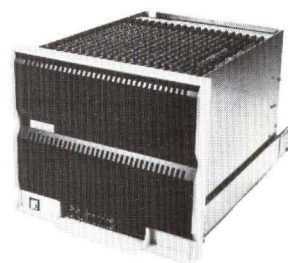

DATARAM BULK MEMORY	EMULATION	MAXIMUM CAPACITY
BS-303 (semi)	6063/6065 (AOS compatible)	8.0 MB
BC-303 (core)	6063/6065	2.0 MB
BS-301 (semi)	NOVADISC	4.0 MB
BC-301 (core)	NOVADISC	2.0 MB

DATARAM

Dataram Corporation □ Princeton Road □ Cranbury, New Jersey 08512 □ (609) 799-0071 □ TWX: 510-685-2542

A TALE of TWO CITIES

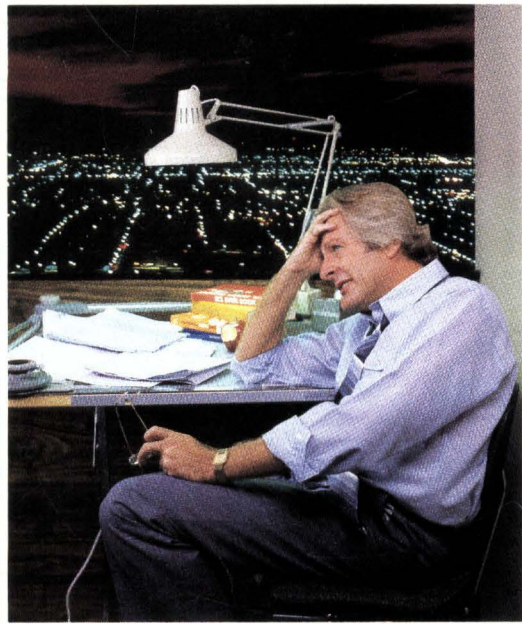

Sunnyvale, California — 8:30 PM



Boca Raton, Florida — 5:00 PM

How FutureNet's DASH-1™ Has Revolutionized Schematic Design and Documentation!

Increased Schematic Design Efficiency

Obviously the engineer in Boca Raton has a big edge over his counterpart in Sunnyvale. The reason is simple. He uses FutureNet's DASH-1 Schematic Designer to create perfect schematics on his IBM PC... in a fraction of the time it takes others who still struggle with manual methods.

Besides producing top-quality schematics, the DASH-1 can automatically generate Net Lists, Lists of Materials, Design Check Reports and other critical support documents. All in all, DASH-1 increases your efficiency as a designer about five-fold... forget those long, wearisome hours slaving over routine documentation.

Extensive Parts Library Included

At the heart of the amazing DASH-1 is a comprehensive symbol library (easily expandable, of course). It includes hundreds of TTL, micro-processor, memory/support chips, as well as discrete components, all

with pinouts and pin functions. Call symbols instantly to your screen, move and connect them effortlessly to create your desired schematic while your DASH-1 automatically captures all the intelligence of your design. An optional plotter even allows you to produce a finished pen and ink drawing in minutes. Should you need it, the DASH-1 has full compatibility with most large CAD systems, as well.

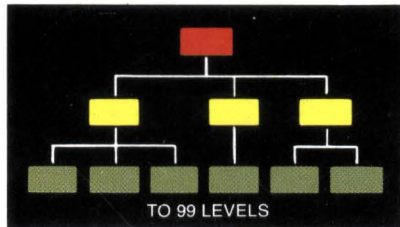

Now... Another Stride Forward!

An exciting new option, STRIDES™ (Structured Interactive Design System), lets you set up a complete "drawing tree" under DASH-1 control. Basically it works like this. When any

drawing is updated, all related Pin Lists, Net Lists, Lists of Materials can also be updated automatically, at one time. And with STRIDES incredible power, up to 99 subordinated levels of drawings, net lists, etc., can be related to each other. Previously, if you could even find this capability on another system, it would cost you 10 to 20 times more than DASH-1.

Productivity of the Future...Today!

In just a few short months, legions of designers throughout the world have discovered the new levels of design productivity and convenience DASH-1 provides. Four out of the top five electronics companies in the USA use DASH-1. At \$5,980 for an add-on package to fit your IBM PC, nothing compares to it for value. Complete turn-key systems are also available at prices starting at \$12,960.

So, no matter which city, state, or country you work in, let DASH-1 give you that efficiency edge.

Give us a call, today!

FutureNet, DASH-1 and STRIDES are trademarks of FutureNet Corporation. IBM is a registered trademark of the IBM Corporation.

FutureNet™

FutureNet Corporation • 21018 Osborne Street • Canoga Park, CA 91304 USA • TWX: 910-494-2681

(818) 700-0691

Productivity of the Future... today.

CIRCLE 164