

digital

RM02/RM03

RM05

handbook

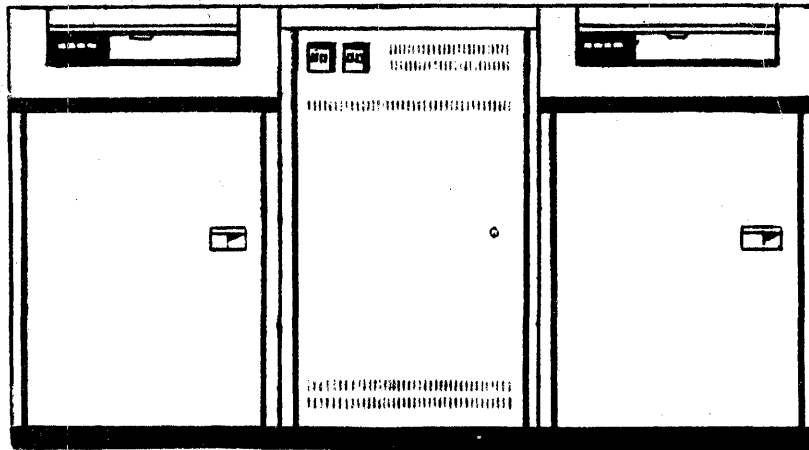

WILLIAM PETERS

129 PARKER STREET, (PK3 - 2/K11), MAYNARD, MASSACHUSETTS 01754
(617) 493 - 4391

RM02/03/05 Handbook
Table of Contents

SECTION ONE:General Information

RMA Register Bit Definitions.....1
VAX 11/780 RM02/03/05 Register Summary.....16
VAX MBA Base Address Charts.....17
RH780 Register Bit Configurations.....18
Module Utilization Charts.....20
Massbus Signal Designations.....21
RM02/03 Part Numbers.....22
RM05 Branch Spares Kits.....26
RM80 RSL.....28

9762 Module Utilization.....32
RM02/03 Module Utilization.....33
RM05 Module Utilization.....34
Drive Interface Cables Signal Designation.....35
RM80 HDA Assembly.....36
RM80 Fault Display Codes.....39
RM02/03/05/80 Documentation.....41

SECTION TWO:Checks and Adjustments

RM02/03 Head Alignment.....1
RM02/03 Index to Burst Measurement.....5
RM02/03 Hit List.....8
RM02/03 Seek Flows.....10
RM05 Head Alignment.....18
RM05 Servo Adjustments.....22
RM05 Write Circuit Tests.....25
RM05 Read Circuit Tests.....27
RM05 Head Amplitude Check.....29
RM05 Track Following Check.....30
RM05 Miscellaneous Checks.....31
RM05 FTU FCO.....34
FIELD SERVICE TECHNICAL MANUAL SUMMARY.....39

INTRODUCTION

The purpose of this handbook is to provide the Field Service Engineer with often used or good to know information. It also puts register bit definitions, module information, adjustment procedures, documentation, and other miscellaneous information into one package.

A smaller disk reference guide in a three or six ring binder is to be developed for publication soon. Separate sections will be developed for different disks such as the RM series disks and the RP04/05/06.

Your comments and ideas are welcome. Please review this copy as it will be the foundation for the printed version. Is it too much? Is it too little? Have you found any technical errors or typos?

It is not the purpose of this book to provide step by step troubleshooting. It is rather to provide a time-saving reference resource which hopefully will aid the engineer in solving the problem.

Please address your comments to:

Bill Peters
Corporate Field Systems Support Group
PK3-2/K11
DTN 223-4391

RM Adapter
Register Bit Definitions

RMCS1 (776700) 00	SC	TRE	MCPE	0	DVA	PSEL	A17	A16	RDY	IE	F4	F3	F2	F1	F0	GO	R/W
----------------------	----	-----	------	---	-----	------	-----	-----	-----	----	----	----	----	----	----	----	-----

BITS 00-05 Drive function field bits 01-05 determine what function the drive will perform. Bit 00 is the GO bit and must be set in conjunction with the function bits before the drive will execute any command. The GO bit is cleared on completion of a command or by an error during the command.

FUNCTION CODES	OPERATION
01	No operation
05	Seek command
07	Recalibrate
11	Drive clear
13	Port release
15	Offset command
17	Return to centerline
21	Read-in preset
23	Pack acknowledge
31	Search command
51	Write check data
53	Write check header and data
61	Write data
63	Write header and data
71	Read data
73	Read header and data

Any other value in this field will set the illegal function bit (ILF) in RMER1.

- BIT 06 Interupt enable. When set by the program, this will generate an interupt upon completion of a command or when an error is encountered.
- BIT 07 Indicates the controller is ready to accept a new command.
- BIT 08 Bus Address Extension Bit 16
- BIT 09 Bus Address Extension Bit 17
- BIT 10 Port Select. Would indicate a transfer which uses the Unibus B feature of an RH11 controller.
- BIT 11 Drive Available. Used in dual port configurations to indicate that the drive is currently available to this controller.

- BIT 12 Not used.
- BIT 13 Mass control parity error. Set when the RH controller detects a parity error on the massbus control lines. This bit would be set as the result of a remote register read in which bad parity was detected. If bad parity occurs during a write to a remote register, the PAR bit in RMER1 would be set.
- BIT 14 Transfer error. Set by DLT, WCE, UPE, NED, NEM, MXF, PGE, MDPE, Or a drive error during a data transfer.
- BIT 15 Special condition. Set by TRE or ATTN or Control Parity Error.

RMWC (776702) RH	WC 15	WC 14	WC 13	WC 12	WC 11	WC 10	WC 9	WC 8	WC 7	WC 6	WC 5	WC 4	WC 3	WC 2	WC 1	WC 0	R/W
---------------------	----------	----------	----------	----------	----------	----------	---------	---------	---------	---------	---------	---------	---------	---------	---------	---------	-----

BITS 00-15 Contains the two's compliment of the number of words to be transferred to or from the drive over the synchronous data bus.

RMBA (776704) RH	BA 15	BA 14	BA 13	BA 12	BA 11	BA 10	BA 9	BA 8	BA 7	BA 6	BA 5	BA 4	BA 3	BA 2	BA 1	BA 0	R/W
---------------------	----------	----------	----------	----------	----------	----------	---------	---------	---------	---------	---------	---------	---------	---------	---------	---------	-----

BITS 00-15 Contains the memory address to which the next transfer will start at. It is incremented by two and does not transfer to odd boundaries. Bit 00 is always read as a zero.

RMDA (776706) 05	0	0	0	TA 16	TA 8	TA 4	TA 2	TA 1	0	0	0	SA 16	SA 8	SA 4	SA 2	SA 1	R/W
---------------------	---	---	---	----------	---------	---------	---------	---------	---	---	---	----------	---------	---------	---------	---------	-----

BITS 00-04 Sector address. Set to the sector desired and increments at the end of each sector transferred.

BITS 08-12 Track address. Set to the desired track and is incremented by the sector address overflow. Note that bits 11-12 are not used by RM02/03.

RMCS2 (776710)RH	DLT	WCE	UPE	NED	NEM	PGE	MXF	MDPE	OR	IR	CLR	PAT	BAI	U2	U1	U0	R/W
---------------------	-----	-----	-----	-----	-----	-----	-----	------	----	----	-----	-----	-----	----	----	----	-----

BITS 00-02 Select a drive on the massbus, 0-7.

BIT 03 Bus Address Increment Inhibit. When set disables the Bus Address register from incrementing on a data transfer.

- BIT 04 Parity Test. When set, the controller generates even parity on both the control bus and the data bus. When clear, the controller normally generates odd parity. Note that when this bit is set it only checks for even parity recieved on the data bus.
- BIT 05 Clear. Setting this bit will initialize the RH controller plus all the drives on the massbus.
- BIT 06 Input Ready. Serves as a status bit to the program to inform it when the RH data buffer is ready to accept another word. If an attempt to write the data buffer is made before the Input Ready bit comes up, it will result in a data late error.
- BIT 07 Output Ready. Indicates that the RH data buffer has a word of data latched in the output. An attempt to read the data buffer before Output Ready comes up will result in a data late error.
- BIT 08 Massbus Data Parity Error. Set when the controller detects bad parity on the synchronous data bus. As with MCPE errors, the bit PAR in RMER1 will set if the parity error ocured during a write to the drive.
- BIT 09 Missed Transfer. Will set if a drive fails to initiate a command for any reason. For instance if you issue a command with an error set. On a data command, missed transfer will be set if the drive does not respond within 250 mS.
- BIT 10 Program error. This will be set if the programmer neglects to check for ready before issueing a command to the RH. Set by any command while the RH is busy.
- BIT 11 Non-existant memory. Set when the controller does not get a response from main memory during a DMA cycle. On 11 systems indicates that memory did not respond to the RMBA by asserting MSYN within 10 uS. When this error occurs the RMBA will contain the bad address plus 2.
- BIT 12 Non-existant drive. Set when the drive selected does not respond (assert TRA) within 1.5 uS after the controller asserts DEM.
- BIT 13 Unibus Parity Error. Set when a parity error is detected on a Write or a Write Check command. The feature is disabled when performing 18 bit transfers.
- BIT 14 Write Check Error. When set indicates that the word read from the disk does not match the corresponding word in main memory. The RMBA will contain the address plus two of the failing word in memory and the RMDB will contain the failing word from the disk.

BIT 15 Data Late. Set when the controller is unable to accept a word during a read or a write-check or is unable to supply a word on a write operation at the time the drive demands it. This error indicates a severely overloaded bus. This bit can also be set by improper reading of the data buffer by the program.



BIT 00 Offset mode. Set when an offset command is issued to the drive. When set and a read command is recieved by the drive, the offset is performed prior to the read. Offset in the RM series drives is always done in a single step one way or the other. You cannot offset in multiple steps as in a RP04,5,&6.

BITS 01-05 Spares. Reserved for future expansion.

BIT 06 Volume Valid. This bit is used to insure that the same disk pack is mounted on the drive as the last time the program used it. Volume Valid is cleared by the assertion of MOL. Therefore, any momentary loss of power, any unsafe condition, or drive address plug change will cause loss of VV. This will crash a software system by causing a fatal mount error.

BIT 07 Drive Ready. Set when ever the drive is ready to accept a new command. Clears immediately on receipt of a command. Setting of this bit indicates normal command termination. If an error is encountered, it will remain reset and the appropriate error bit will set.

BIT 08 Drive Present. Always set as long as there is power to the RM Adapter.

BIT 09 Programmable. Indicates that the drive is selected to operate in the dual port mode.

BIT 10 Last Block Transferred. This bit is set when the last addressable block on the disk pack has been transferred. Cleared by writing a new disk address into the RM desired cylinder register or track address register. This bit is used to prevent a spiral read on the pack from wrapping around to cylinder 0. An attempt to read or write with this bit set will result in an AOE.

- BIT 11 Write Locked. Set when the manual write protect switch on the drive is depressed or when MOL is not asserted. The drive will not accept any write commands in this state.
- BIT 12 Medium On Line. Indicates that the drive has succeeded in loading heads and is on cylinder. Any change in power status or if heads are unloaded, the MOL will reset. Dropping MOL will set ATA.
- BIT 13 Positioning in Progress. Set only during the execution of positioning commands until the heads are settled over the correct cylinder. If PIP was set as a result of a direct positioning command such as SEEK, ATA will be asserted at the completion. ATA would not be asserted at the completion of positioning caused by implied seeks.
- BIT 14 Error. This is a composite of any error bit in the RMER1 or RMER2 registers.
- BIT 15 Attention. This bit will set on any error if GO bit is set, at the completion of a command or if GO bit reset, at the occurrence of the error. It will also set anytime MOL changes state. Cleared by Drive Clear or by writing a one into the bit in the ATA summary register.

RMER1 (776714) 02	DCK	UNS	OPI	DTE	WLE	IAE	AOE	HCRC	HCE	ECH	WCF	FER	PAR	RMR	ILR	ILF	R/W
----------------------	-----	-----	-----	-----	-----	-----	-----	------	-----	-----	-----	-----	-----	-----	-----	-----	-----

- BIT 00 Illegal Function. Set by loading an invalid code into the function field of RMCS1 (with GO and no previous errors). ILF is a class B error.
- BIT 01 Illegal Register. Set by trying to read or write a massbus register whose number is greater than 17 octal. ILR is a class A error.
- BIT 02 Register Modification Refused. Set when trying to write into any register except RMAS or RMMR1 while the GO bit is active. RMR is a class A error.
- BIT 03 Parity Error. Set by the drive detecting a parity error on information sent to it by the controller. If the parity error is on the Massbus control lines, the PAR bit sets and is classified as a class A error. If the parity error is detected on the data bus, then DPE of RMER2 will set also. This condition is a class B error.

- BIT 04 Format Error. Set to indicate that bit 12 of the sector header does not agree with bit 12 of the RMOF register. This generally indicates that a pack formatted in 18 bit mode has been installed on 16 bit machine or vice versa. This bit will be inhibited if bit 10 of RMOF (HCI) is set and will always be invalid if bit 08 of RMER1 (HCRC) is set. FER is a class A error during a Read header and data command and is a class B error during all other commands.
- BIT 05 Write Clock Fail. Set by the drive if it does not receive write clock from the controller within 1.6uS after asserting sync clock on a write or write header command. WCF is a class B error.
- BIT 06 ECC Hard Error. Indicates that the ECC logic was unable to correct the error. An ECC hard error is defined as an error burst greater than 11 bits in length. ECH is a class B error.
- BIT 07 Header Compare Error. The first word of the header read does not match the RMDC (cylinder address) or the second word of the header does not match the contents of the RMDA (sector and track address). This is a positioning error as the drive did not go to the address specified by the controller. The meaning of this bit is not valid if HCRC is set. HCE is a class A error during a read header command and a class B error during all others.
- BIT 08 Header CRC error. Set if the CRC word generated by reading the header did not compare with the CRC word that was written in the header at the time the disk was formatted. HCRC is a class A error during a read header and data command and is a class B error during all others.
- BIT 09 Address overflow error. Set when the controller requests a data transfer to a block beyond the disk addresses which are possible. Note that when AOE is set, the contents of RMDA will increment at EBL time even though the command was terminated. AOE is a class B error.
- BIT 10 Invalid Address Error. Set when an invalid cylinder address, track address, or sector address are used in trying to perform a read or write or seek or search command. This differs from AOE in the respect that AOE is an overflow from the last sector of the last track of the last cylinder of the pack during a data command. IAE is a class B error.
- BIT 11 Write Lock Error. Set if a write command is issued to a write protected drive. WLE is a class B error.

- BIT 12 Drive Timing Error. Set when a sector pulse is detected during sector compare time. This usually is the result of installing an unformatted pack. Any time the SYNC byte of a sector is not detected a drive timing error could result. DTE is a class B error.

- BIT 13 Operation Incomplete. Set primarily by three conditions: Drive does not respond to a command on the tag bus within 300 nS (Does not drop +On Cylinder) with a Seek command. Drive does not find a sector within three revolutions of the disk with a search command. Or; The massbus run signal is not asserted within 20 mS after the GO bit is set. OPI is a class B error.

- BIT 14 Unsafe. A condition exists which prevents the normal operation of the drive, such as low AC power. See RMER2.

- BIT 15 Data Check Error. Set if after reading the entire data field, bits 11-31 are non-zero. DCK is a class A error if ECI of RMOF is set and it is a class B error if ECI of RMOF is cleared.

RMAS (776716) 04

0	0	0	0	0	0	0	0	ATA 7	ATA 6	ATA 5	ATA 4	ATA 3	ATA 2	ATA 1	ATA 0
---	---	---	---	---	---	---	---	----------	----------	----------	----------	----------	----------	----------	----------

R/W

BITS 00-07 Indicate which drives attention conditions exist on. Bit 00 equals drive zero, bit 07 equals drive seven. Clear by writing a one into the appropriate bit position.

RMLA (776720) 07

0	0	0	0	0	SC 16	SC 8	SC 4	SC 2	SC 1	0	0	0	0	0	0
---	---	---	---	---	----------	---------	---------	---------	---------	---	---	---	---	---	---

R

BITS 00-05 SPARES

BITS 06-09 Sector count lines. Indicates the current sector that the heads are positioned over.

BITS 10-15 SPARES

RMDB	DB	DB	DB	DB	DB	DB	DB	DB	DB	DB	DB	DB	DB	DB	DB	DB	R
(776722) RH	15	14	13	12	11	10	9	8	7	6	5	4	3	2	1	0	

BITS 00-15 RM Data Buffer. When reading this register, the contents of the RH OBUF will be displayed. When writing this register, the data will go into the RH IBUF and will move toward the OBUF as the silo emptys.

RMMR1	OCC	R/G	EBL	REX	ESRC	PLFS	ECRC	PDA	PHA	CONT	WC	ECC	WD	LS	LST	DMD	R
(776724) 03	DBCK	DBEM	DEBL	MSEN	MCLK	MRD	MUR	MOC	MSER	MDF	MS	DTG	MWP	MI	MSC	DMD	W

Bit assignments for RMMR1 Read-Only portion:

- BIT 00 Diagnostic Mode. Set to put RM Adapter in to the maintenance and diagnostic mode.
- BIT 01 Last Sector / Track. Used to fake the condition of a last sector on a track and force the cylinder address to increment as in a mid-transfer seek.
- BIT 02 Last Sector. Used to fake the last sector of a track in order to increment heads as in a spiral read.
- BIT 03 Write Data. Imitates the serial write data normally fed to the disk. Depending on when it is read, it can emulate the output of the data register, the ECC generator, or the CRC generator.
- BIT 04 Enable ECC Out. This bit is only set during write operations when the ECC pattern is being written.
- BIT 05 Prom Strobe. One complete prom cycle requires 16 bit clocks and controls the generation of read and write timing in the RMA. Produced by the Servo clock except during a read when it is a function of the read clock.
- BIT 06 Continue. Set at the end of EBL if the run line is still active, the controller continues to perform the data transfer as long as this bit is active.
- BIT 07 Header Area. This bit is generated by the data sequencer to indicate that the header has been found. It is set by the header sync byte and cleared by the header CRC area.
- BIT 08 Data Area. Same as above except set by the data sync byte and cleared by the last word in a sector.

- BIT 09 Enable CRC Out. During a write operation this bit is set by the data sequencer to enable the CRC to be written following the data field.
- BIT 10 Looking for Sync. Set during the sector gap to indicate that the sequencer is looking for the sync byte for the next sector. During this time the word clock is inhibited to the data sequencer.
- BIT 11 Enable Search. This indicates that the search logic is enabled and is looking for rotational position. When sector compare comes up, this bit will reset and the data sequencer will be activated.
- BIT 12 Exception. This reflects the status of the Mass Exception line.
- BIT 13 END OF BLOCK. Set by the adapter to indicate that the last block of data has been transferred.
- BIT 14 Run and GO. Set when the massbus run line is active and the GO bit is set.
- BIT 15 Occupied. Set when the synchronous data bus is involved in a valid transfer. Cleared on the trailing edge of GO.

Bit assignments for RMMR1 write-only portion:

- BIT 00 Diagnostic Mode. Sets the RM Adapter in maintenance mode and completely isolates the drive from the adapter.
- BIT 01 Sector Compare. Simulates the function of the sector compare logic.
- BIT 02 Index Pulse. Simulates the function of the drive index pulse. Used primarily to check out the format logic.
- BIT 03 Write Protect. Allows the diagnostic to verify the write protect logic.
- BIT 04 NOT USED.
- BIT 05 Sector Pulse. Simulates the drives sector pulse to clock logic in the sector compare circuits.
- BIT 06 Drive Fault. Used by the diagnostic to simulate the drive fault signal.
- BIT 07 Seek Error. Fakes a seek error to occur from the disk drive.

- BIT 08 On Cylinder. Simulates the on cylinder signal in the disk drive.
- BIT 09 Unit Ready. Set by the diagnostic to indicate that the pack is spun up and ready.
- BIT 10 Read Data. Simulates serial data read from the disk drive.
- BIT 11 Maintenance Clock. Used to control the data flow through the adapter in maintenance mode. When used with read gate asserted, simulates read clock. If used with write gate asserted, simulates servo clock.
- BIT 12 Search Time-out Disable. Inhibits the search time-out if the sector is not found within two revolutions to give the diagnostic functions time to operate.
- BIT 13 Diagnostic EBL. Allows the diagnostic to step through the command sequencer states without completing an entire command. EBL is the signal which can terminate.
- BIT 14 D. Clk. En.. Allows the programmer to debug the control sequencer by single stepping the system clock.
- BIT 15 Debug Clock. This is the bit the programmer would toggle to simulate the system clock if bit 14 were set.

	15	14	13	12	11	10	09	08	07	06	05	04	03	02	01	00	
RMDT (776726) 06	0	0	MOH 1	0	DRQ	0	0	DT 8	DT 7	DT 6	DT 5	DT 4	DT 3	DT 2	DT 1	DT 0	R

BITS 00-08 Drive Type Register

BIT 11 Drive Request Required. If set indicates a dual port drive.

BIT 13 Moving Head. Since all RM series drives are moving head devices, this bit is hard-wired in the RMA.

	SN	SN	SN	SN	SN	SN	SN	SN	SN	SN	SN	SN	SN	SN	SN	SN	
RMSN (776730) 10	8000	4000	2000	1000	800	400	200	100	80	40	20	10	8	4	2	1	R

BITS 00-15 This is the RM serial number register.

RMOF (776732) 11	0	0	0	FMT 16	ECl	HCl	0	0	OFF DIR	0	0	0	0	0	0	0	R/W
---------------------	---	---	---	-----------	-----	-----	---	---	------------	---	---	---	---	---	---	---	-----

BITS 00-06 Not used, always zero.

BIT 07 Offset Direction. When set, the offset direction is toward the spindle. When reset, the offset direction is away from the spindle. This bit is valid if the Offset Mode bit is set by loading an offset command into RMCS1.

BITS 08-09 Not used, always zero.

BIT 10 Header Compare Inhibit. This bit allows the hardware to read a pack in which the header is bad or invalid. Setting this bit disables bits 07, 08 of the RMER1 register. This is a useful tool in troubleshooting positioning errors. It is recommended that you reset this bit before trying to do a write.

BIT 11 Error Correction Inhibit. This allows the drive to read the disk in spite of a data check error because it disables the normal ECC check that is done at the end of the data field. Used by the diagnostic to troubleshoot ECC and data errors.

BIT 12 Format. When set, selects 16 bit word length in the format of the pack. Reset, equals 18 bit length. If this bit does not agree with the format bit written in the header, the format error bit in RMER1 will set on a data transfer command.

BITS 13-15 Not used, always zero.

RMDC (776734) 12	0	0	0	0	0	0	DC 512	DC 256	DC 128	DC 64	DC 32	DC 16	DC 8	DC 4	DC 2	DC 1	R/W
---------------------	---	---	---	---	---	---	-----------	-----------	-----------	----------	----------	----------	---------	---------	---------	---------	-----

BITS 00-09 Desired Cylinder Address Register. Bit 00 is the least significant bit and bit 09 is the most significant bit. Loading this register with a value larger than the maximum cylinder address possible will result in an invalid address error in RMER1.

RMHR (776736) 13	0	0	0	0	0	0	0	0	0	0	0	0	0	0	0	0	0	R/W
---------------------	---	---	---	---	---	---	---	---	---	---	---	---	---	---	---	---	---	-----

The holding register is used by the diagnostic and has no drive function. It shadows any other valid register and holds a two's complement of it's data.

RMMR2
(776740) 14

RQA	RQB	TAG	TEST BIT	CIC	CIH	BB 9	BB 8	BB 7	BB 6	BB 5	BB 4	BB 3	BB 2	BB 1	BB 0
-----	-----	-----	----------	-----	-----	------	------	------	------	------	------	------	------	------	------

R

BITS 00-09 Tag Bus Bits. These read-only bits reflect the state of the tag bus which runs between the RMA and the RM02/03/05/80 logic panel. This bus has three functions depending on which 'tag' line is asserted. The table below describes the possible functions associated with each bit.

<u>BUS BIT</u>	<u>CYLINDER TAG</u>	<u>HEAD TAG</u>	<u>CONTROL TAG</u>
BB 00	1	1	Write gate
BB 01	2	2	Read gate
BB 02	4	4	Servo offset plus
BB 03	8	8	Servo offset minus
BB 04	16	16	Not used
BB 05	32	Not used	Not used
BB 06	64	Not used	Return to Zero
BB 07	128	Not used	Not used
BB 08	256	Not used	Not used
BB 09	512	Not used	Not used

BIT 10 Control or Head Select. This bit is used to indicate the type of function that the bus bits are currently used for. If set, the tag is either control or head select. If reset, this means the tag is for cylinder address select. Read-only.

BIT 11 Control or Cylinder Select. This bit is used to indicate the type of function that the bus bits are currently used for. If set, the tag is either control or cylinder select. If reset, this means the tag is for head select. Read-only.

NOTE: It should be obvious that if both bits 10 and 11 are set, then the function must be control select. However, they deemed it necessary to designate bit 13 as the control select indicator. The reason for this is because only one function should be selected at a time. So if you see more than one tag line active at the same time, then one of them must be hung.

- BIT 13 Control Tag. Indicates the status of the control select tag line. (See description under bits 10 and 11).
- BIT 14 Request B. Indicates that a request has been recieved from port B. Read-only.
- BIT 15 Request A. Indicates that a request has been recieved from port A. Read-only.

RMER2
(776742) 15

BSE	SKI	OPE	IVC	LSC	LBC	0	0	DVC	0	0	0	DPE	0	0	0	R/V
-----	-----	-----	-----	-----	-----	---	---	-----	---	---	---	-----	---	---	---	-----

- BITS 00-02 Not used, always zero.
- BIT 03 Data Parity Error. When set, indicates that a parity error has occurred on the synchronous data bus during a data transfer. (That even parity was detected.) DPE also causes PAR in RMER1 to set. DPE is a class B error.
- BITS 04-06 Not used, always zero.
- BIT 07 Device check. Set by the drive as an indication of low AC power or multiple head select failure. DVC is a class B error.
- BITS 08-09 Not used, always zero.
- BIT 10 Loss of bit clock. Set if no transition of the bit clock (derived from the servo and read clocks) occurs for more than 400 nS. LBC is a class B error.
- BIT 11 Loss of system clock. The system clock referred to is the RMA clock which strobes the micro prom sequencer. This bit will be set if the prom states do not change and therefore the clock is dead. LSC is a class B error.
- BIT 12 Invalid Command. Set when a command is recieved while Volume Valid or Drive Ready are not set. IVC is a class B error.
- BIT 13 Operator plug error. Set when the logical address plug has been removed from the drive. If the plug is removed during a data transfer, it is a class B error. If removed any other time, it is a class A error.
- BIT 14 Seek Incomplete. Sets if the drive is unable to complete a seek within 500 mS or if the heads move into the inner or outer guard band. In either case, the position of the heads cannot be determined, so you must issue a recalibrate command to get the heads back to zero.

BIT 15 Bad Sector Error. If in checking bits 14 and 15 of the first header word, the drive finds a zero in either, this bit will be set to indicate that this sector has been flagged bad. This is a class B error which will cause termination of a read command after the CRC has been read. This will be a class A error in the case where a read header and data are performed.

RMCE1
(776744) 16

0	0	0	P 4096	P 2048	P 1024	P 512	P 256	P 128	P 64	P 32	P 16	P 8	P 4	P 2	P 1
---	---	---	-----------	-----------	-----------	----------	----------	----------	---------	---------	---------	--------	--------	--------	--------

R

BITS 00-12 ECC Position Register. This register gives the binary position of the correctable error burst within the data field just read. A correctable error burst is one in which the total length of the burst in error is not greater than 11 bits. Any errors that occur more than 11 bits apart cannot be corrected. This register points to the first bit in error out of a data field 16 bits long by 256.

NOTE: When a correctable data check occurs, the sector in error has already been transferred to memory. It is the software system which must correct the error in memory. To do this, the software takes the value in the position register and calculates the position of the burst in memory. Then it takes the value from the ECC pattern register and uses it to calculate which bits must be corrected.

RMCE2
(776746) 17

0	0	0	0	0	PAT 11	PAT 10	PAT 9	PAT 8	PAT 7	PAT 6	PAT 5	PAT 4	PAT 3	PAT 2	PAT 1
---	---	---	---	---	-----------	-----------	----------	----------	----------	----------	----------	----------	----------	----------	----------

R

BITS 00-10 ECC Pattern Register. Contains the actual error burst pattern detected by the ECC logic. Any or all of these 11 bits may be in error so long as there are no errors greater than 11 bits.

RMBAE
(776750) RH

0	0	0	0	0	0	0	0	0	0	0	A21	A20	A19	A18	A17	A16
---	---	---	---	---	---	---	---	---	---	---	-----	-----	-----	-----	-----	-----

R/W

BITS 00-05 Bus Address Extension. These extra six address bits would be used by the RH70 to develop the full 22 bit addressing of the PDP 11/70 memory bus.

RMCS3
(776752) RH

APE	DPE HI	DPE LO	WCE HI	WCE LO	DBL	0	0	0	IE	0	0	IPCK 3	IPCK 2	IPCK 1	IPCK 0
-----	-----------	-----------	-----------	-----------	-----	---	---	---	----	---	---	-----------	-----------	-----------	-----------

R/W

BITS 00-03 Invert parity check. Setting these bits will cause the parity to be inverted on the associated byte.
 IPCK 00 = Byte 00; IPCK 01 = Byte 01; IPCK 02 = Byte 02
 IPCK 03 = Byte 03.

BITS 04-05 Not used.

BIT 06 Interrupt Enable. This bit shadows the interrupt enable bit in RMCS1. They are one and the same. The only difference with this one is that it will allow you to enable interrupts on the RH without writing a drive register. (Remember that to set the interrupt bit on RMCS1, you will initiate a write to the drive since the function bits are in the same register.)

BITS 07-09 Not used.

BIT 10 Double word. Read-only. Indicates that the data transfer in progress is 32 bits wide. On the PDP 11/70 the RH will transfer two words only if the desired data is on an even boundary in memory. If the data is on an odd boundary or the word count equals one, the RH will transfer 16 bits.

BIT 11 Write check error Even word. When the data word in the RH OBUF (from the disk) did not compare with the word in memory, this bit will set. WCE causes the RHDB to latch the failing word from the disk.

BIT 12 Write check error Odd word. Same as bit 11 except error occurred in the odd (Hi) word.

BIT 13 Data Parity Error Even Word. If set, the even word in memory had a data parity error. This condition is checked on a write or a write-check operation.

BIT 14 Data Parity Error Odd Word. Same as bit 13 except odd word.

NOTE: With either bits 13 or 14 set, the bit UPE will set in RMCS2. Don't forget to concatenate the RMBAE with the RMBA to get the physical address. If the double word bit was set in this register, subtract 4 from the RMBA. If the double bit is not set, subtract 2. This will give you the address of the bad word in memory.

BIT 15 Address Parity Error. If set, an address parity error was detected on the 22 bit address bus. The procedure for finding the bad address is the same as explained in the note above. APE also sets UPE in RMCS2.

VAX-11/780 RM05 REGISTER SUMMARY

RMCS1															OFFSET FROM BASE (HEX)	
15	14	13	12	11	10	09	08	07	06	05	04	03	02	01	00	
SC	TRE	MCPE	Ø	DVA	PSEL			RDY	IE	F4	F3	F2	F1	F0	G0	00
RMDS																
ATA	ERR	PIP	MOL	WRL	LBT	PGM	DPR	DRY	VV	Ø	Ø	Ø	Ø	Ø	ØM	04
RMER1																
DCK	UNS	OPI	DTE	WLE	IAE	AOE	HCRC	HCE	ECH	WCF	FER	PAR	RMR	ILR	ILF	08
RMMR1																
OCC	R-G	EBL	REX	ESRC	PLFS	ECRC	RDA	PHA	CONT	WC	EECC	WD	LS	LSIT	DMD	
DACK	DBEN	DEBL	MSEN	MCLK	MRD	MUR	MOC	MSER	MDF	MS	DTG	MWP	MI	MSC	DMD	0C
RMAS																
Ø	Ø	Ø	Ø	Ø	Ø	Ø	Ø	ATA	ATA	ATA	ATA	ATA	ATA	ATA	ATA	10
								7	6	5	4	3	2	1	Ø	
RMDA																
Ø	Ø	Ø	TA*	TA*	TA	TA	TA	Ø	Ø	Ø	SA	SA	SA	SA	SA	14
			16	8	4	2	1				16	8	4	2	1	
RMDT																
Ø	Ø	MOH	Ø	DRØ	Ø	Ø	DT	DT	DT	DT	DT	DT	DT	DT	DT	18
							8	7	6	5	4	3	2	1	Ø	
RMLA																
Ø	Ø	Ø	Ø	Ø	SC	SC	SC	SC	SC	Ø	Ø	Ø	Ø	Ø	Ø	1C
					16	8	4	2	1							
RMSN																
SN	SN	SN	SN	SN	SN	SN	SN	SN	SN	SN	SN	SN	SN	SN	SN	20
8000	4000	2000	1000	800	400	200	100	80	40	20	10	8	4	2	1	
RMOF																
Ø	Ø	Ø	FMT	ECI	HCI	Ø	Ø	OFF	Ø	Ø	Ø	Ø	Ø	Ø	Ø	24
			16					DIR								
RMDC																
Ø	Ø	Ø	Ø	Ø	Ø	DC	DC	DC	DC	DC	DC	DC	DC	DC	DC	28
						512	256	128	64	32	16	8	4	2	1	
RMHR																
Ø	Ø	Ø	Ø	Ø	Ø	Ø	Ø	Ø	Ø	Ø	Ø	Ø	Ø	Ø	Ø	2C
RMMR2																
REQ	REQ	TAG	TEST	CIC	CIH	BB	BB	BB	BB	BB	BB	BB	BB	BB	BB	30
A	B		BIT			9	8	7	6	5	4	3	2	1	Ø	
RMER2																
Ø	SKI	OPE	IVC	LSC	LBS	Ø	Ø	DVC	Ø	Ø	Ø	DPE	Ø	Ø	Ø	34
RMEC1																
Ø	Ø	Ø	P	P	P	P	P	P	P	P	P	P	P	P	P	38
			4096	2048	1024	512	256	128	64	32	16	8	4	2	1	
RMEC2																
Ø	Ø	Ø	Ø	Ø	PAT	PAT	PAT	PAT	PAT	PAT	PAT	PAT	PAT	PAT	PAT	3C
					11	10	9	8	7	6	5	4	3	2	1	

VAX 11/780 MBA DEVICE REGISTER
ADDRESS CALCULATIONS

1st MBA Base Address 20010400
2nd MBA Base Address 20012400

REGISTER NUMBER		DRIVE TYPE			DRIVE NUMBER							
HEX	OCTAL	RP (DISK)	RM (DISK)	TE (TAPE)	0	1	2	3	4	5	6	7
0	0	CS1	RMCS1	CS1	0	80	100	180	200	280	300	380
1	1	DS	RMDS	DS	4	84	104	184	204	284	304	384
2	2	ER1	RMER1	ER	8	88	108	188	208	288	308	388
3	3	MR	RMMR1	MR	C	8C	10C	18C	20C	28C	30C	38C
4	4	AS	RMAS	AS	10	90	110	190	210	290	310	390
5	5	DA	RMDA	FC	14	94	114	194	214	294	314	394
6	6	DT	RMDT	DT	18	98	118	198	218	298	318	398
7	7	LA	RMLA	CX	1C	9C	11C	19C	21C	29C	31C	39C
8	10	SN	RMSN	SN	20	A0	120	1A0	220	2A0	320	3A0
9	11	OFF	RMOF	TC	24	A4	124	1A4	224	2A4	324	3A4
A	12	DCA	RMOC		28	A8	128	1A8	228	2A8	328	3A8
B	13	CCA	RMNR		2C	AC	12C	1AC	22C	2AC	32C	3AC
C	14	ER2	RMMR2		30	B0	130	1B0	230	2B0	330	3B0
D	15	ER3	RMER2		34	B4	134	1B4	234	2B4	334	3B4
E	16	ECCPOS	RMEC1		38	B8	138	1B8	238	2B8	338	3B8
F	17	ECCPAT	RMEC2		3C	BC	13C	1BC	23C	2BC	33C	3BC
.
.
.
1F	37				7C	FC	17C	1FC	27C	2FC	37C	3FC

MBA REGISTER ADDRESS OFFSETS

OFFSET FROM LINE SBI ADDRESS	REGISTER	OFFSET FROM BASE PHYSICAL ADDRESS	
00	Configuration Register (CSR)	00	R/W
01	Control Register (CR)	04	R/W
02	Status Register (SR)	08	R/W
04	Virtual Address Register (VAR)	0C	R/W
05	Byte Counter Register (BCR)	10	R/W
06	Diagnostic Register (DR)	14	R/W
07	Selected MAP Register (SMR)	18	Read only
08	Command/Address Register (CAR)	1A	Read only

MBA 0 Base 20010000
MBA 1 Base 20012000

RH780 Bit Configurations

00 MBA Configuration Register (CSR)

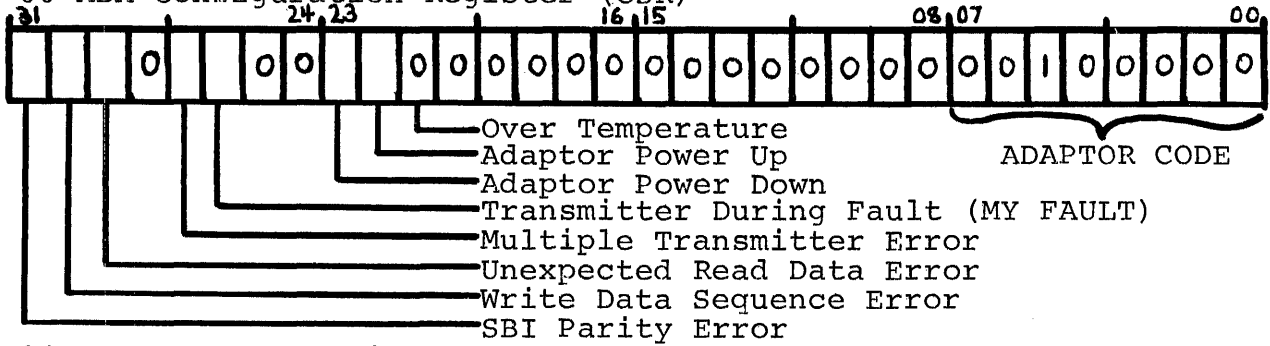

04 MBA Control Register

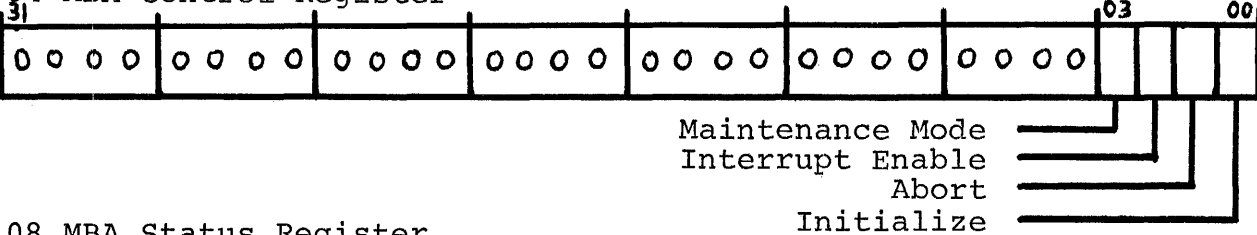

08 MBA Status Register

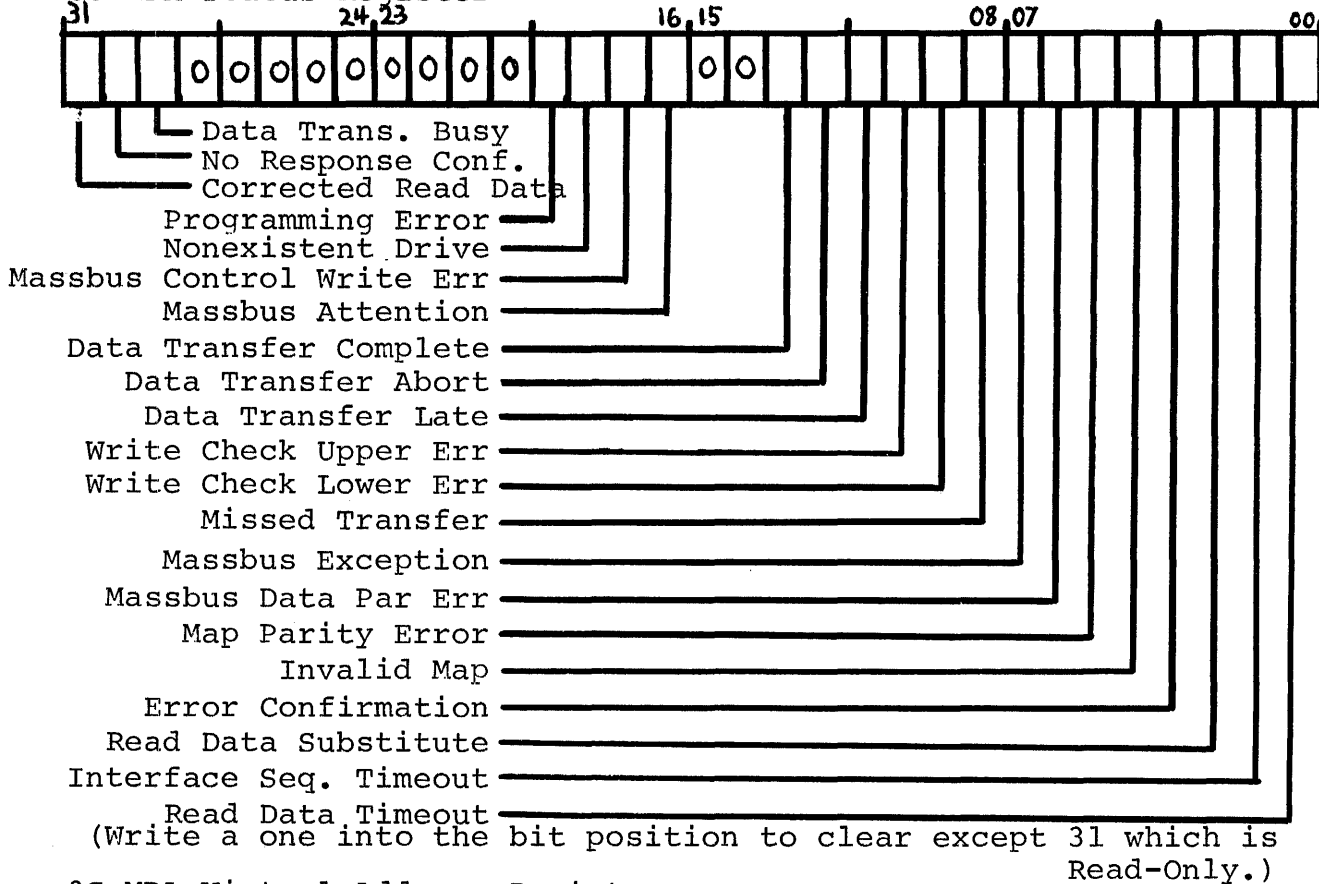

0C MBA Virtual Address Register

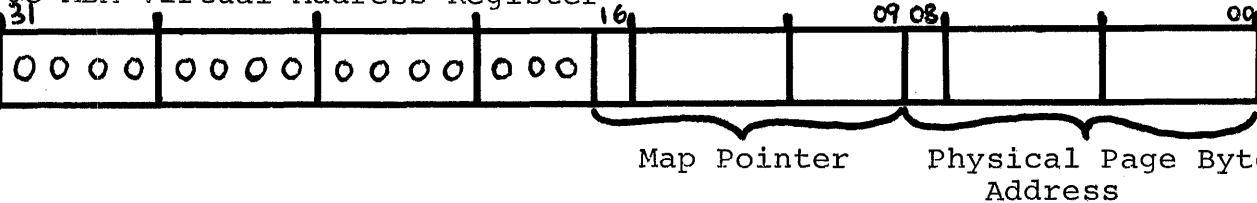

RH780 Bit Configurations

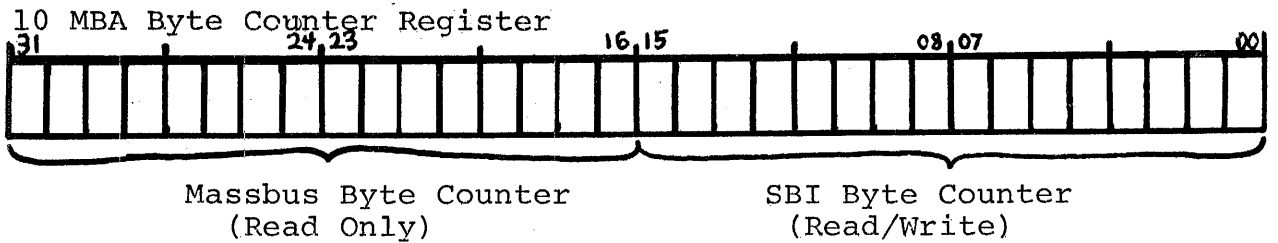

Data written into the SBI byte counter is copied into the Massbus byte counter. (2's complement of number of bytes to transfer.)

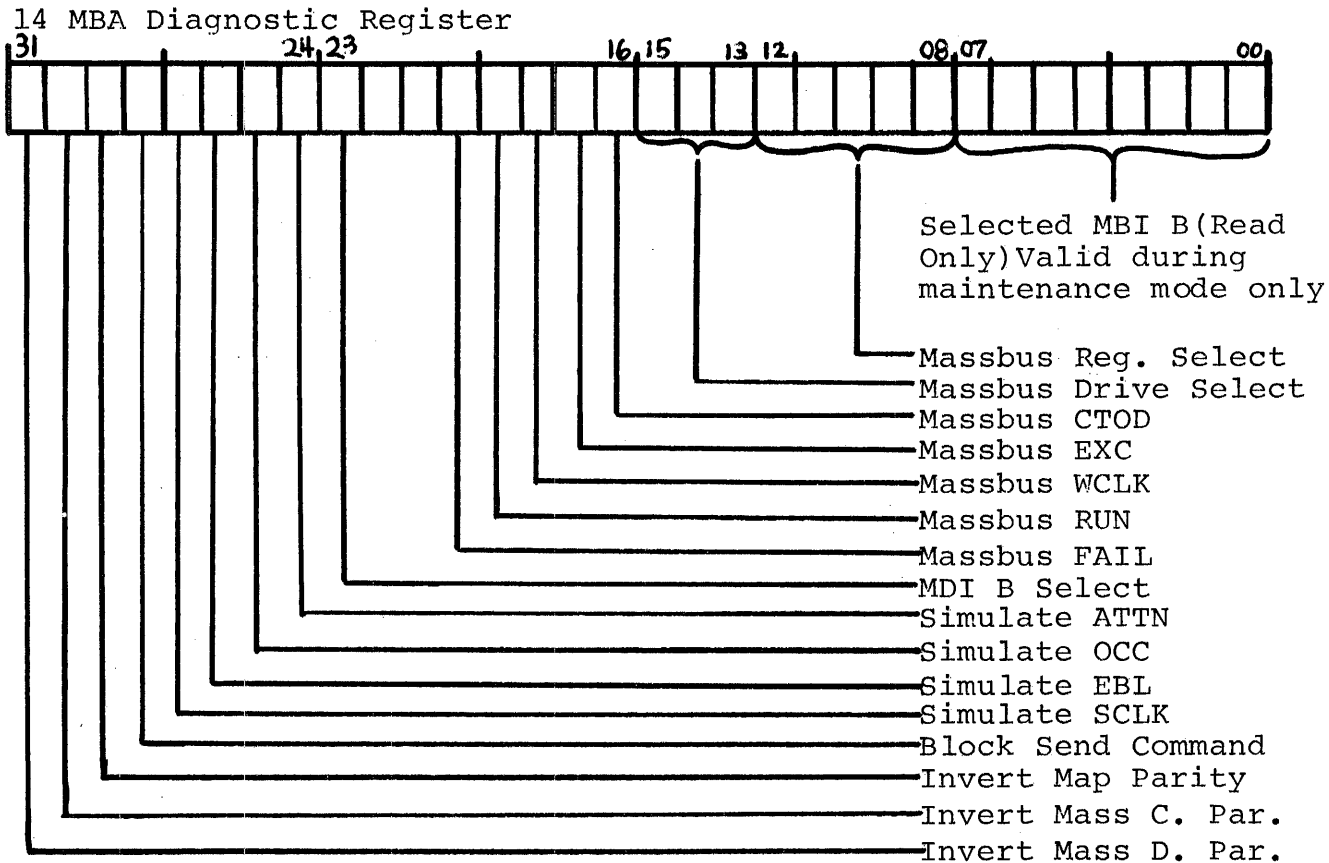

Bits 21 and 22 are Read/Write for diagnostic purposes only.

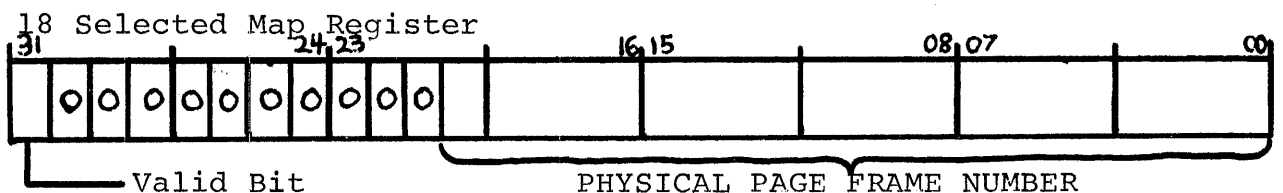

MODULE UTILIZATION CHARTS
(Front View)

RH-780	
Blank Module	
Blank Module	
M8278	MCP
M8277	MDP
M8276	MIR
M8275	MSI

RH-70	
M8153	M5904 C
M8152	M5904 B
M8151	M5904 A
M8150	MDP

RM02/03/05/80 Adapt.	
M7684	
7687	
M7685 or M8685	
M7686	
	M5922 A
	M5922 A
M5923	B
M5923	B

RMA Module compatability charts

MODULE	RM02/03	RM80	RM05
M7684	CS = R	yes	yes
M7685 M7685-YA M8685	CS = C yes yes	no no yes	no CS = D CS = B
M7686 ** M7686-YA	CS = J yes	yes yes	no yes
M7687	CS = C	yes	yes
M5922	CS = E	yes	yes
M5923	CS = E	yes	yes
70-13398 Back Plane	WL = C WT = D	WL = D WT = E	WL = D WT = E

** If DUAL PORT Switches are located in the slot on the front door M7686-YA must be used.

RM Adapter Backplane Revision Level:

The following changes have been made to the RM02/03 backplane to make it RM02/03/05/80 compatible.

For the RM05:

ADD BP3600 RPM L.....A06K2 to B05P2

For the RM80:

ADD NEW TRK READ L.....A06H1 to A09R1
 RMOF L.....B05H2 to A06H2
 RMER2 H.....B05F2 to A06F2
 SSE.....E05U2 to E06L1

With all 5 wires added, the 'WL' is at a REV 'D' and the 'WT' is at a REV 'E'. This makes the 70-13398 Backplane RM02/03/05/80 compatible.

In addition to this, the RM80 requires a special jumper on slot 06 of the RMA backplane grounding C06D1 to C06C2. This changes the cylinder address scheme and must be removed for all other drives.

Cable	Pin*	Polarity	Designation	Cable	Pin*	Polarity	Designation	Cable	Pin*	Polarity	Designation
Massbus Cable A	A	1	-	Massbus Cable B	A	1	-	Massbus Cable C	A	1	-
	B	2	+		B	2	+		B	2	+
	C	3	+		C	3	+		C	3	+
	D	4	-		D	4	-		D	4	-
	E	5	-		E	5	-		E	5	-
	F	6	+		F	6	+		F	6	+
	H	7	+		H	7	+		H	7	+
	J	8	-		J	8	-		J	8	-
	K	9	-		K	9	-		K	9	-
	L	10	+		L	10	+		L	10	+
	M	11	+		M	11	+		M	11	+
	N	12	-		N	12	-		N	12	-
	P	13	-		P	13	-		P	13	-
	R	14	+		R	14	+		R	14	+
	S	15	+		S	15	+		S	15	+
	T	16	-		T	16	-		T	16	-
	U	17	-		U	17	-		U	17	-
	V	18	+		V	18	+		V	18	+
	W	19	+		W	19	+		W	19	+
	X	20	-		X	20	-		X	20	-
Y	21	-	Y	21	-	Y	21	-			
Z	22	+	Z	22	+	Z	22	+			
AA	23	+	AA	23	+	AA	23	+			
BB	24	-	BB	24	-	BB	24	-			
CC	25	-	CC	25	-	CC	25	-			
DD	26	+	DD	26	+	DD	26	+			
EE	27	+	EE	27	+	EE	27	+			
FF	28	-	FF	28	-	FF	28	-			
HH	29	+	HH	29	+	HH	29	+			
JJ	30	-	JJ	30	-	JJ	30	-			
KK	31	-	KK	31	-	KK	31	-			
LL	32	+	LL	32	+	LL	32	+			
MM	33	-	MM	33	-	MM	33	-			
NN	34	+	NN	34	+	NN	34	+			
PP	35	+	PP	35	+	PP	35	+			
RR	36	-	RR	36	-	RR	36	-			
SS	37	+	SS	37	+	SS	37	+			
TT	38	-	TT	38	-	TT	38	-			
UU	39		UU	39		UU	39	H			
VV	40		VV	40		VV	40	GND			

Cable A

Cable B

Cable C

MASSBUS SIGNAL AND PIN DESIGNATIONS

RM02/RM03 DEC to CDC PART NUMBERS

<u>CD KIT</u>	<u>DESCRIPTION</u>	<u>RM03 DEC #</u>	<u>BK5B5 #</u>	<u>RM02 DEC #</u>	<u>BK8A1 #</u>
03	Fuse 2A 250V	29-22872	95 647602	same	
03	Fuse 6A 250V	29-22873	95 647605	same	
03	Fuse 8A 250V	29-23587	95 647606	same	
--	Magnet Assy	29-22874	47 200700	same	
* 03	HRVV RXer	29-22875	54 147709	same	
03	ASGV Speed detect	29-23117	54 152505	same	*(note 29-22876/6SGV obsolete)
03	ASHV (BSHV) Power Sup +5v	29-22877	54 152901(902)	same	(fuse change only)
03	5SJV (ASJV) Power Sup +42v	29-22878	54 153300(301)	same	(fuse & bleader res. change)
03	5SKV Power Supply +20v	29-22879	54 153700	same	
03	JTVV TXer (as HTVV)	29-22880	54 167710	same	
03/02	HFRV (JFRV) Fine Servo	29-22881	54 226113	29-23112	54 226114
03	EKVV Fault Reg	29-22882	54 262105	same	
03	FLPV Servo Control	29-22883	54 275307	same	
03	JLQV D/A Converter	29-22884	54 275710	same	
03/02	HLRV (LLRV) Data Latch	29-22885	54 276108	29-23113	54 276113
03/02	CLSV (BLSV) Write PLO	29-22886	54 276503	29-23111	54 276502
03/02	ELTV (NLTV) A-Cont/Sect	29-22887	54 276906	29-23116	54 276914
03	ELUV A-Cont 2	29-22888	54 277306	same	
03	MLVV A-Cont 1	29-22889	54 277713	same	
03	FLWV Diff Generator	29-22890	54 278107	same	
03	ELXV NRZ to MFM	29-22891	54 278505	29-23115	54 278509 *See attached Tech-Tip.
03/02	BLZV (CLZV) Read PLO	29-22892	54 279303	29-23114	54 279304
--	Meter Hour 60 HZ	29-22893	94 313800	same	
03	FZQN Servo PreAmp	29-22894	73 485311	same	
03/02	R/W Head Lower	29-22895	75 010102	29-23109	75 010302
03/02	R/W Head Upper	29-22896	75 010103	29-23107	75 010303
03/02	R/W Head Servo	29-22897	75 010105	29-23108	75 010305
03/02	NZJN (SZJN) HD Sel/Amp	29-22898	75 061715	29-23119	75 061719
03/02	EZKN (DZKN) WR Driver	29-22899	75 062107	29-23118	75 062106
--	Spindle Assy	29-22900	75 074714	29-23373	75 074703
03	Blower Assy 60 HZ	29-22901	75 240304	same	

RM02/RM03 DEC to CDC Part #'s cont

<u>CD KIT</u>	<u>Description</u>	<u>RM03 DEC #</u>	<u>BK5B5 #</u>	<u>RM02 DEC #</u>	<u>BK8A1 #</u>
03	Blower Assy 50 HZ	29-22902	75 240305	same	
03	Brake assy hysteresis	29-22903	75 241500	same	
03	Control Panel assy	29-22904	76 422501	same	
--	Flex Lead assy	29-22905	76 426800	same	
03	Transducer Assy	29-22906	76 427300	same	
--	Transformer 60hz	29-22907	76 840400	same	
--	Transformer 50 hz	29-22908	76 846800	same	
03	Speed Sensor assy	29-22909	77 387101	same	
--	Carriage & Coil assy	29-22910	77 398303	same	
03(02)	Motor Drive 60 hz	29-22911	47 204303	29-23121	47 204301
03(02)	Motor Drive 50 hz	29-22912	47 204310	29-23122	47 204309
03	5VTN Servo Power	29-22913	77 569100	same	
03	Tool sensor height adj	29-22914	87 052600	same	
03(02)	Drive Belt 60 hz	29-22915	92 314113	29-23110	92 314099
03(02)	Drive Belt 50 hz	29-22916	92 314119	29-23120	92 314115
--	CKT Breaker 5A/60hz p/s	29-22917	92 696065	same	
--	CKT Breaker 5A/60hz p/s	29-22918	92 696079	same	
03	Sw Interlock	29-22919	93 560002	same	
03	Sw mini	29-22920	93 786005	same	
--	CKT Bkr 8A 50hz Main	29-22921	94 245205	same	
--	CKT Bkr 5A 60hz Main	29-22922	94 245217	same	
--	242-292(161-193)MFD 60hz	29-22923	94 255116	29-23137	94 255112
--	Meter hour 50 hz	29-22924	94 313807	same	
03	Filter air 15.77 x 11	29-22925	94 364700	same	
03	Filter air	29-23368	73 022800	same	
--	4MFD 370VAC cap	29-22927	94 365800	same	
--	Line Filter 10A	29-22928	94 371200	same	
03	120v Sw Solid State (TRIAC)	29-22929	76 427404	same	(replaces 94-371303 & 5)
--	21000 MFD 50VDC	29-22930	95 578111	same	
03	Card extender	29-22933	54 109701	same	
03	240v Sw Solid State (TRIAC)	29-23313	76 427406	same	

RM02/RM03 DEC to CDC PART NUMBERS

<u>CD KIT</u>	<u>DESCRIPTION</u>	<u>RM03 DEC #</u>	<u>BK5B5 #</u>	<u>RM02 DEC #</u>	<u>BK8A1 #</u>
03	Carr/Spindle Adj Tool	29-22934	75 018400	same	
03	Head Adj Tool	29-22935	75 018804	same	
03	Bit 1/4 Hex Hd Adj	29-22936	87 016701	same	
--	6 MFD 660 VAC CAP	29-22938	95 686701	same	
--	Rail,Lower carr guide	29-23028	75 063600	same	
--	Rail,Upper carr guide	29-23029	75 063700	same	
--	270-324 MFD Cap 50HZ Dr Mot	29-22937	94 255109	same	(S/C 15-19)
--	" " " " " "	29-23586	94 255101	same	(S/C 20-26)
--	" " " " " "	29-22937	94 255120	same	(S/C 27)
--	(#1) Pivot Pin Pack Cover R.H.	29-23374	75 070000	same	
--	(#1) Pivot Pin Pack Cover L.H.	29-23375	75 070001	same	
--	Spring Gas-Pack Cover	29-23376	94 354903	same	
--	Emergency Retract Relay	29-23377	94 378509	same	
--	Lockshaft, Spindle	29-23524	76 425600	same	
<u>Misc:</u>	RM03-FTU Cables	RM03-FTU	TB3A2 (A+B)	Same	
	"A" Cable 60 pin	none	83 249802	same	
	"B" Cable 26 pin	none	83 254302	same	
	Hd Align Cable	none	77 440300	same	
	DEC Dual Port Test Cable	70-10507-02	none	same	Used with Diag CZRMGB0
	LATCH & SPRING assy	29-23599	73 023500	same	for pack access cover
	Coding keys (unit #'s)	70-14352-00	none	same	set 0-7 same as TM02/TM03
	coding keys (unit Ø)	12-11902-00	none	same	-00 to -07 is unit #'s
(#1)	Retainer,shroud cover	29-23633	73 063600	same	** @1
	Bushing, pack cover	29-23634	76 429600	same	** @2 Larger diam hinge
	Washer, slide	29-23635	75 174202	same	** @2 pins - order all
	Hinge pin, Right	29-23636	75 070002	same	** @1
	Hinge pin, Left	29-23637	75 070003	same	** @1 5 parts in @x numbers
these 5 parts make up the larger diam. hinge pins and obsoletes 29-23374 & 29-23375 - - - - -					

"C"

Voltage and Frequency Dependent Components

RM03 3600RPM=BK5BXX	BK5B5G(120V/60HZ)	BK5B5H(240V/50HZ)	BK8A1A(120V/60HZ)	BK8A1B(240V/50HZ)	
RM02 2400RPM=BK8AXX					
VARISTOR	CDC #	NONE	94395600	NONE	94395600
	DEC #	-	-	-	-
BLOWER ASSEMBLY		75240304	75240305	75240304	75340305
		29-22901	29-22902	29-22901	29-22902
SOLID STATE SWITCH		94371305/76427404	94376501/76427406	94371305/76427404	94376501/76427406
RUN/START TRIAC		29-22929	29-23313	29-22929	29-23313
HOUR METER		94313800	94313807	94313800	94313807
		29-22893	29-22924	29-22893	29-22924
TRANSFORMER		76840400	76846800	76840400	76846800
		29-22907	29-22908	29-22907	29-22908
P.S. CIRCUIT BREAKER		92696065	92696079	92696065	92696079
		29-22917	29-22918	29-22917	29-22918
MAIN CIRCUIT BREAKER		94245217	94245205	94245217	94245205
		29-22922	29-22921	29-22922	29-22921
DRIVE BELT		92314113	92314119	92314099	92314115
		29-22915	29-22916	29-23110	29-23120
DRIVE MOTOR KIT		47204303	47204310	47204301	47204309
		29-22911	29-22912	29-23121	29-23122
CAP DRIVE MOTOR**		94255116	94255120 SC-27 UP	94255112	94255120 SC-27 UP
		29-22923	29-22937	29-23137	29-22937
POWER CABLE		75259410	75259409	75259410	75259409
		-	-	-	-
METER MOUNTING PLATE		75256100	75256102	75256100	75256102
		-	-	-	-
**CAP DRIVE MOTOR		SC-15 thru SC-19	240V/50HZ = 94255109		
		SC-20 thru SC-26	240V/50HZ = 94255101 = DEC # 29-23586		

RM05 Branch Spares Kit (60Hz)
A2-W0336-10

SPARES KIT #1.....A2-S0051-0
 SPARES KIT #2.....A2-S0052-0
 SPINDLE ASSEMBLY.....29-23559
 ACTIVATOR ASSEMBLY.....29-23572
 BLOWER ASSEMBLY.....29-23573
 DRIVE MOTOR.....29-23574
 DATA PACK.....30-17107-00
 CE PACK.....30-17108-00

RMA Spares Kit
A2-W0335-10

H7740 POWER SUPPLY.....70-13784
 15 VOLT REGULATOR.....54-11086

A2-S0051-0 RM05 Spares Kit #1

<u>Vendor PN</u>	<u>DEC PN</u>	<u>Description</u>	<u>Qty.</u>	<u>Unique</u>
75183604	29-23540	Comp.Assy. Type AZCN	1	RM05
77427502	29-23543	Comp.Assy. Type AYFN	1	RM05
54122900	29-23554	Card Read Amp 4PHV	1	RM05
54123301	29-23555	Card Write Driver 5PJV	1	RM05
54123700	29-23556	Card R/W Control 4PKV	1	RM05
54135308	29-23557	Card Diff & Head FQPV	1	RM05
54262501	29-23558	Card Access Cont. AKGV	1	RM05
54296505	29-23553	Card Analog Servo DMSV	1	RM05
75054500	29-23566	Card Reg. 5V	1	RM05
75208502	29-23568	Card Serial Head BXGN	1	RM05
75243202	29-23569	Card Servo 5ZGN	1	RM05
54277721	29-23577	Card Access RLVV	1	RM05
54147709	29-22875	Card Channel 1 HRVV	1	RM03/5
54167710	29-22880	Card Channel 2 JTVV	1	RM03/5
54226113	29-22881	Card Fine Servo HFRV	1	RM03/5
54262105	29-22882	Card Fault EKRV	1	RM03/5
54276108	29-22885	Card Data Latch HLRV	1	RM03/5
54276503	29-22886	Card Write Clock CLSV	1	RM03/5
54276906	29-22887	Card Access Cont ELTV	1	RM03/5
54278107	29-22890	Card Difference FLWV	1	RM03/5
54278505	29-22891	Card NRZ to MFM ELXV	1	RM03/5
54279303	29-22892	Card Read PLO BLZV	1	RM03/5
73385311	29-22894	Card Track Servo FZQN	1	RM03/5
54109701	29-22933	Card Extender	1	RM03/5

RM05 Absolute Filter 29-23591 Purge all date codes from June 1, 1981 to October 31, 1981 from shelf stock and drives. See Tech Tip at end of Handbook.

A2-S0052-00 RM05 Spares Kit #2

<u>Vendor PN</u>	<u>DEC PN</u>	<u>Description</u>	<u>Qty.</u>	<u>Unique</u>
77427100	29-23541	Comp. Assm.	1	RM05
75010400	29-23656	Head Arm Assm.	10	RM05
75010401	29-23657	Head Arm Assm.	9	RM05
75010409	29-23658	Head Arm Assm. Servo	1	RM05
92314087	29-23575	Belt 60 HZ	1	RM05
92314093	29-23584	Belt 50 HZ	1	RM05
12218425	29-13212	Tool Screwdriver	1	RM05
12263205	29-20906	Tool Torque Wrench	1	RM05
75018400	29-22934	Tool Carriage/Spindle	1	RM05
75018803	29-22935	Tool Head Adj.	1	RM05
87016701	29-22936	Tool Screwdriver	1	RM05
76422501	29-22904	Cont. Pan. Switch Assm.	1	RM03/5
A2-W0335-10		RMA Controller Kit	RM03/5	
	M5922	RMA Transciever A	1	
	M5923	RMA Transciever B	1	
	M7684	Control Sequencer	1	
	M7685	Data Sequencer	1	
	M7686	Control Interface	1	
	M7687	Drive Data Interface	1	

RM05 POWER SUPPLY PART NUMBERS

<u>Vendor PN</u>	<u>Description</u>
94376500	Solid State Switch AC 15 Amp
94371302	Solid State Switch AC 30 Amp
94371301	Solid State Switch AC 15 Amp
94355401	Filter Low Leakage
76804200	Transformer Ferro 60 Hz
76804000	Transformer Ferro 50 Hz
47317900	Transformer Assm. 50/60 Hz
50242705	Rectifier Bridge
95686701	Capacitor 660 VAC
75183604	Comp. Assm. Power Amp. Type AZCN
77427100	Comp. Assm. Capacitor Board Type 5YEN
94378200	Contactoer 24V DC Power
77427502	Comp. Assm. Relay Board AYFN
92696031	Circuit Breaker .5 Amp
94268303	Circuit Breaker 2 Amp 50 VDC
92696023	Circuit Breaker 5 Amp
92696001	Circuit Breaker 8 Amp
94268308	Circuit Breaker 7 Amp 50 VDC
94245209	Circuit Breaker Drive Motor
94268315	Circuit Breaker .375 Amp 250 VAC
94245211	Circuit Breaker AC Main Power
94313808	Hour Meter 60Hz

RM80 Disk Drive

RSL

Part Number	Description
BC06Y-YB	18 ft. shielded, massbus cable
H7440	Adapter +5v regulator
H766A	Power supply, 120v/60 Hz
H766B	Power supply, 220v/50 Hz
M5922	MASSBUS transceiver A
M6923	MASSBUS transceiver B
M7684	Control sequencer module
M7686-YA	Control interface module
M7687	Drive interface module
M8685	Data sequencer module
10-16924-00	Motor start cap, 115v./60 Hz
10-17217-00	Motor start cap, 220v./50 Hz
12-09403-02	Fan, 117 CFM, ball bearing
12-10719-03	Fan, 117 VAC, ball bearing
12-11714-00	MBA Fan, 115v., ball bearing
12-12635-03	Belt, 60 Hz
12-12635-04	Belt, 50 Hz
12-12691-00	ID cap (0/READY)
12-12691-01	ID cap (1/READY)
12-12691-02	ID cap (2/READY)
12-12691-03	ID cap (3/READY)
12-12691-04	ID cap (4/READY)
12-12691-05	ID cap (5/READY)
12-12691-06	ID cap (6/READY)
12-12691-07	ID cap (7/READY)
12-12714-00	Switch cap (RUN/STOP)
12-12714-01	Switch cap (WRIT PROT)
12-12714-02	Switch cap (FAULT)
12-12714-30	Switch cap (STAT 1)
12-12714-31	Switch cap (STAT 2)
12-12716-00	Lamp wedge, 6.3v
12-14011-00	Microswitch (1PSA)
12-16817-00	Optical switch (speed sensor)
12-16870-00	HDA thermal switch
12-17072-00	Gas spring
29-23187-00	Spares case
54-11086-00	MBA, 15v regulator
54-13596-00	Read/Write module
54-13641-00	Control panel module
54-14012-00	Microprocessor module (DCL)
70-14038-00	26 - Pin Cable
70-14039-00	60 - Pin Cable
70-16215-00	Brush ground assembly
70-16225-00	Head disk assembly (HDA)
70-16230-00	Wing pivot assembly

RM80 Disk Drive

RSL CON'T

70-16723-00	115v/60 Hz motor brake assy
70-16723-01	220v/50 Hz motor brake assy
70-16724-00	Actuator assembly (BTRM)
70-16732-00	Logic D.C. power cable
70-16733-00	Logic A.C. harness assembly
-70-16735-00	Servo preamp cable assembly
-70-16737-00	40 conductor data cable (person)
70-16737-01	40 conductor data cable (servo)
70-16738-00	20 conductor data cable (person)
70-16738-01	20 conductor data cable (R/W)
-70-16739-00	50 conductor read/write cable
70-16740-00	Control panel cable assembly
70-16742-00	Shock mount assembly
70-16975-00	Personality module/stiffer
70-16976-00	Servo module/stiffner
-70-16978-00	26 conductor I/O cable (top half cable)
-70-16979-00	60 conductor I/O cable (top half cable)
70-16980-00	Belt tension SW assembly
70-17335-00	Line cord assembly 115v/60 Hz
70-17335-01	Line cord assembly 220v/50 Hz
74-22440-00	Motor tension spring
74-22816-00	Foam Air filter (front bezel)

ARL

Part Number	Description
54-13596	Read/write module
54-14012	Microprocessor module
70-16225	HDA
70-16975	Personality/stiffener
70-16976	Servo/stiffener
H766A	Power supply - 60 Hz
H766B	Power supply - 50 Hz
M5922	MASSBUS transceiver A
M5923	MASSBUS transceiver B
M7684	Control sequencer
M8685	Data sequencer
M7686-YA	Control interface
H7440	+5v regulator

RM80 Adder Branch Spares Kit - 50 Hz - EUR (A2-W0445-11)

Same as US Area Kits with the following exception:

H766-B Power Supply at 746.24 vs H766-A

RM80 Disk Drive

RM80 Generic Branch Spares Kit - 60HZ - USA (A2-W0444-10)

Part Number	Description	Qty	Std. Cost
12-12635-03	Belt, 60 HZ	1	2.19
12-14011-00	Microswitch	1	1.01
12-16817-00	Speed Sensor	1	8.38
29-23187-00	Spares Case	1	61.75
54-13596-00	Read/write module	1	92.18
70-16215-00	Brush ground assemblies	2	.23
70-16225-00	HDA	1	3,127.62
70-16723-00	Motor brake assembly	1	161.68
70-16976-00	Servo/stiffener	1	260.39
74-22440-00	Motor tension springs	2	.11
74-22816-00	Air filters	2	1.00
			<u>\$3,716.88</u>

RM80 Generic Branch Spares Kit - 50HZ - EUR (A2-W0444-11)

Same as US Area Kits with following exceptions:

- 12-12635-04 Belt, 50 HZ at \$3.83 vs 12-12635-03
- 70-16723-01 Motor Break Assembly at \$168.83 vs 70-16723-00

RM80 Adder Branch Spares Kit - 60 HZ - USA - (A2-W0445-10)

Part Number	Description	Qty	Std. Cost
H766-A	Power Supply	1	745.74
12-12691-00	ID Cap (0/Ready)	5	.70
12-12691-01	ID Cap (1/Ready)	5	.92
12-12691-02	ID Cap (2/Ready)	5	.93
12-12691-03	ID Cap (3/Ready)	5	.88
12-12691-04	ID Cap (4/Ready)	5	.93
12-12691-05	ID Cap (5/Ready)	5	.93
12-12691-06	ID Cap (6/Ready)	5	.69
12-12691-07	ID Cap (7/Ready)	5	.69
54-13641-00	Control panel assy	1	45.15
54-14012-00	Microprocessor module	1	261.55
70-16975-00	Personality/stiffener	1	124.11
			<u>\$1,183.22</u>

KEY

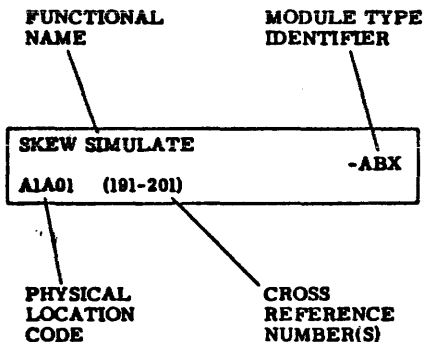

± 5 V POWER SUPPLY	-SHV
A1A03 (331-333)	
± 12 V AND ± 20 V	-SKV
A1A02 (321-322)	
± 42 V POWER SUPPLY AND EMERGENCY RETRACT	
A1A01 (311-312)	

TRACK SERVO PREAMP	-QZN
A3A05 (201-202)	

POWER AMPLIFIER	
A3A04 (281-282)	

CHAN II I/O A1D2 (241-243)	-XYZ-	CHAN I XMTRS AND RCVRs	-TVV	WRITE CLOCK 806 KHz	-LSV
		A2B01 (111-113)		A2A01 (011-013)	
		CHANNEL I RECEIVERS	-RVV	FTU/HEAD ALIGNMENT CARD SLOT	
		A2B02 (121-124)		A2A02 (021-022)	
		CHAN II XMTRS AND RCVRs	-TVV	FINE SERVO DECODER	-FRV
		A2B03 (131-133)		A2A03 (031-033)	
		CHANNEL II RECEIVERS	-RVV	FAULT CARD	-KfV
		A2B04 (141-144)		A2A04 (041-044)	
		DUAL CHANNEL STEERING	-KfV	DATA LATCH	-LRV
		A2B05 (151-154)		A2A05 (051-053)	
CHAN I I/O A2D1 (231-233)	-XYZ-	DIFF GEN AND CONTROLS	-LWV	READ PLO	-LZV
		A2B06 (161-165)		A2A06 (061-065)	
		NRZ TO COMPENSATED MFM	-LXV	D/A FUNCTION GENERATOR	-LQV
		A2B07 (171-173)		A2A07 (071-073)	
		ACCESS CONTROL AND INDEX/SECTOR DECODE	-LTV	ACCESS CONTROL NO. 2	-LUV
		A2B08 (181-185)		A2A08 (081-085)	
		ACCESS CONTROL NO. 1		SWITCHING MODE CONTROL	-LPV
		A2B09 (191-184)		A2A09 (091-093)	
		DUAL CHANNEL INTERRUPT AND CHANNEL I XMTRS	-SMV	INTERLOCKS AND SPEED CONTROLS	-SGV
		A2B10 (201-203)		A2A10 (101-104)	
CHAN II TERMINATOR A2C2 (221-222)	-YDV				
CHAN I TERMINATOR A2C1 (211-212)	-YDV				

WRITER	-ZQN
A3A03 (371-373)	
HEAD SELECT AND READ AMPLIFIER	-ZJN
A3A03 (361-363)	

OPERATOR CONTROL PANEL	-ZYN
A3A01 (251-253)	

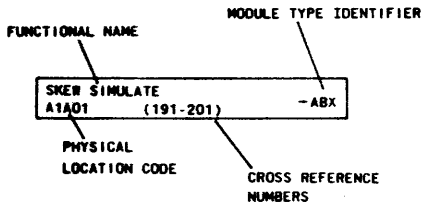

±5 V POWER SUPPLY	-SHV
A1A03 (331-333)	
±12 V AND ±20 V	-SKV
A1A02 (321-322)	
±42 V PWR SUPPLY & EMERGENCY RETRACT	-SJV
A1A01 (311-312)	

TRACK SERVO PREAMP	-ZQN
A3A05 (291-292)	
POWER AMPLIFIER	-VTN
A3A04 (281-282)	

TRANSMITTERS	-TVV	WRITE CLOCK 806 KHz	** -LSV
A2B01 (111-113)		A2A01 (011-013)	
RECEIVERS	-RVV	FTU/HEAD ALIGNMENT CARD SLOT	
A2B02 (121-124)		A2A02 (021-022)	
①		FINE SERVO DECODER	** -FRV
①		A2A03 (031-035)	
①		FAULT CARD	-KFV
DIFF GEN AND CONTROL	-LWV	A2A04 (041-045)	
A2B06 (161-165)		DATA LATCH	** -LRV
NRZ TO COMPENSATED MFM	-LXV	A2A05 (051-053)	
A2B07 (171-173)		READ PLO	** -LZV
ACCESS CONTROL & INDEX/SEE DECODE	-LTV	A2A06 (061-065)	
A2B08 (181-184) **		D/A FUNCTION GENERATOR	-LQV
ACCESS CONTROL NO. 1	-LVV	A2A07 (071-073)	
A2B09 (191-194)		ACCESS CONTROL NO. 2	-LUV
①		A2A08 (081-085)	
		SWITCHING MODE CONTROL	-LPV
		A2A09 (091-093)	
		INTERLOCKS & SPEED DETECTOR	-SGV
		A2A10 (101-104)	

WRITER	-ZRN
A3A03 (271-274)	
HEAD SELECT & READ AMPLIFIER	-ZJN
A3A02 (261-263)	

OPERATOR CONTROL PANEL	-ZYN
A3A01 (251-252)	

**Denotes modules not interchangeable between RM02 and RM03 drives.

NOTE:
① NOT USED

CONTROL DATA NORMAN DALE DIVISION	CHASSIS MAP	CODE IDENT	C	83322680	A	A
		CROSS REF. NO.		SHEET 2	PAGE 1-12	

KEY	FUNCTIONAL NAME CROSS REF NO	MODULE TYPE IDENTIFIER
-----	---------------------------------	---------------------------

LOGIC CHASSIS

A01	XMTRS/RCVRS, HD ADD REG 011-013	_TVV
A02	RCVRS 021-024	_RVV
A03	NOT USED	
A04	NOT USED	
A05	NOT USED	
A06	ACCESS CNTL, INDEX/SECTOR DECODE 061-064	_LTV
A07	ACCESS CNTL NO. 1 071-074	_LVV
A08	DIFF BITS, HD REG, SPEED, UNIT SEL 081-084	_OPV
A09	NOT USED	
A10	WRT CLK 101-103	_LSV
A11	NOT USED	
A12	DIFF GEN AND CNTL 121-125	_LWV
A13	NRZ TO MFM 131-133	_LXV
A14	DATA LATCH 141-143	_LRV
A15	READ PLO 151-155	_LVZ
A16	NOT USED 	
A17	FAULT CARD 171-175	_KPV

LOGIC CHASSIS

A18	FINE SERVO DECODE 181-185	_FRV
A19	ACCESS CONTROL NO. 2 191-194	_KGV
A20	ANALOG SERVO 201-204	_MSV



READ/WRT CHASSIS

E01	RD/WRT CNTL 611-613	_PKV
E02	WRT DRVR 621-622	_PJV
E03	RD AMPLIFIER 631-633	_Phv
E04	DIODE MATRIX AND MOTHER BOARD 641-642	_XFN
E06	HD SEL 651-654	_XGN



	TRACK SERVO PREAMP 761-763	_ZON
--	-------------------------------	------



	OPERATOR PANEL 771-773	_ZYN
---	---------------------------	------

POWER SUPPLY

	RELAY BOARD 811-813	_YFN
	CAPACITOR BOARD 821-822	_YEN
	POWER AMP 831-832	_ZCN

LOGIC CHASSIS



± 5 VOLT REGULATOR
841-844

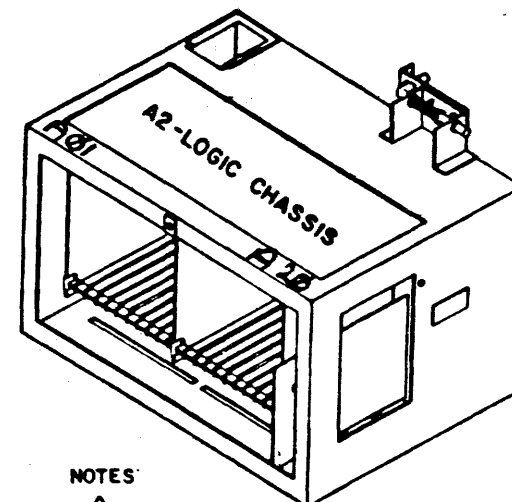

NOTES:



LOCATED ON DECK



PLUGS INTO A2PD94 FROM CARD SIDE OF LOGIC CHASSIS

3.

FOR SPECIFIC CARD TYPE REFER TO SPARE PARTS LIST.



USED FOR HEAD ALIGNMENT CARD DURING MAINTENANCE

RM05 Logic Chassis
and Module Utilization
Chart.

CONTROLLER

(←)	+Unit Select Tag	52	(+Plug Valid)	→
(←)	-Unit Select Tag	22	(-Plug Valid)	→
(←)	+Unit Select Bit 0	53	(+Select Add 1)	→
(←)	-Unit Select Bit 0	23	(-Select Add 1)	→
(←)	+Unit Select Bit 1	54	(+Select Add 2)	→
(←)	-Unit Select Bit 1	24	(-Select Add 2)	→
(←)	+Unit Select Bit 2	56	(+Select Add 4)	→
(←)	-Unit Select Bit 2	26	(-Select Add 4)	→
(←)	+Unit Select Bit 3	57	(+Sector Cnt 1)	→
(←)	-Unit Select Bit 3	27	(-Sector Cnt 1)	→
(←)	+Tag 1	31		→
	-Tag 1	1		→
	+Tag 2	32		→
	-Tag 2	2		→
	+Tag 3	33		→
	-Tag 3	3		→
	+Bit 0	34		→
	-Bit 0	4		→
	+Bit 1	35		→
	-Bit 1	5		→
	+Bit 2	36		→
	-Bit 2	6		→
	+Bit 3	37		→
	-Bit 3	7		→
	+Bit 4	38		→
	-Bit 4	8		→
	+Bit 5	39		→
	-Bit 5	9		→
	+Bit 6	40		→
	-Bit 6	10		→
	+Bit 7	41		→
	-Bit 7	11		→
	+Bit 8	42		→
	-Bit 8	12		→
	+Bit 9	43		→
	-Bit 9	13		→
(←)	+Open Cable Detect	44	(+Sector Cnt 2)	→
(←)	-Open Cable Detect	14	(-Sector Cnt 2)	→
←	+Index	48		→
←	-Index	18		→
←	+Sector	55		→
←	-Sector	25		→
←	+Fault	45		→
←	-Fault	15		→
←	+Seek Error	46		→
←	-Seek Error	16		→
←	+On Cylinder	47		→
←	-On Cylinder	17		→
←	+Unit Ready	49		→
←	-Unit Ready	19		→
←	+Address Mark	50	(+Sector Cnt 4)	→
←	-Address Mark	20	(-Sector Cnt 4)	→
←	+Write Protect	58		→
←	-Write Protect	28		→
←	-Power Sequence Hold	59		→
←	-Sequence Pick In	29		→
(←)	SPARE	51	(+Sector Cnt 8)	→
(←)	SPARE	21	(-Sector Cnt 8)	→
(←)	SPARE	60	(+Sector Cnt 16)	→
(←)	SPARE	30	(-Sector Cnt 16)	→

SMD DRIVE

"B" CABLE

CONTROLLER				
		Ground	1	
←		-Servo Clock	2	
←		+Servo Clock	14	
		Ground	15	
←		-Read Data	3	
←		+Read Data	16	
		Ground	4	
←		-Read Clock	5	
←		+Read Clock	17	
		Ground	18	
		-Write Clock	6	
		+Write Clock	19	→
		Ground	7	→
		-Write Data	8	
		+Write Data	20	→
		Ground	21	→
←		-Unit Selected	22	(-Sector 30+32) (→)
←		+Unit Selected	9	(+Sector 30+32) (→)
←		-Seek End	10	(-Start Enable) (→)
←		+Seek End	23	(+Start Enable) (→)
		Ground	11	
(←)		Spare	12	
(←)		Spare	24	
		Ground	25	
		Spare	13	(+Initialize) (→)
		Spare	26	(-Initialize) (→)

SMD DRIVE

SMD INTERFACE (DEC "MBA" LINES)

BY: Greg Ekholm

RM80 HDA Assembly
(Bottom View)

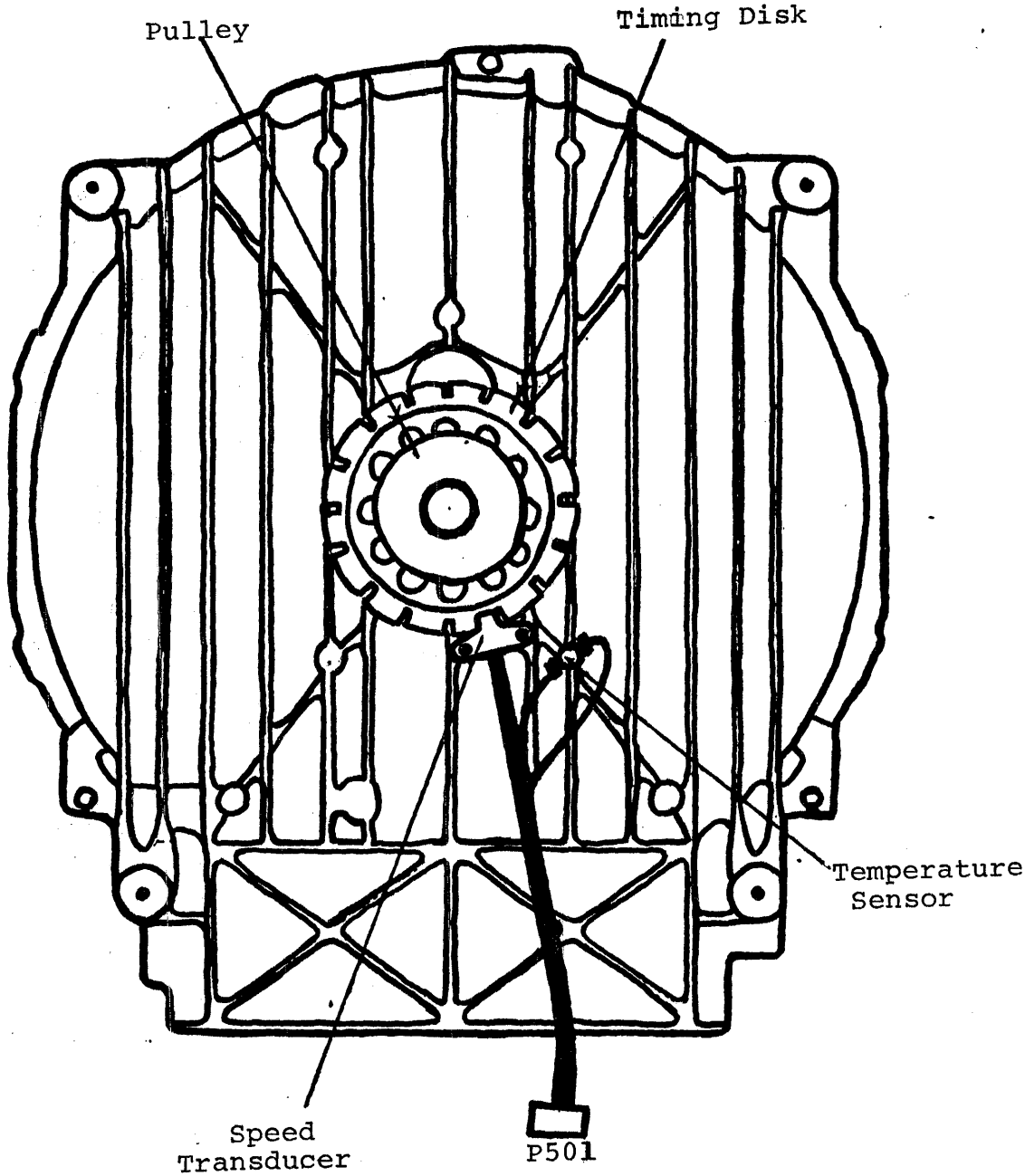

RM80 HDA Assembly
(Top View)

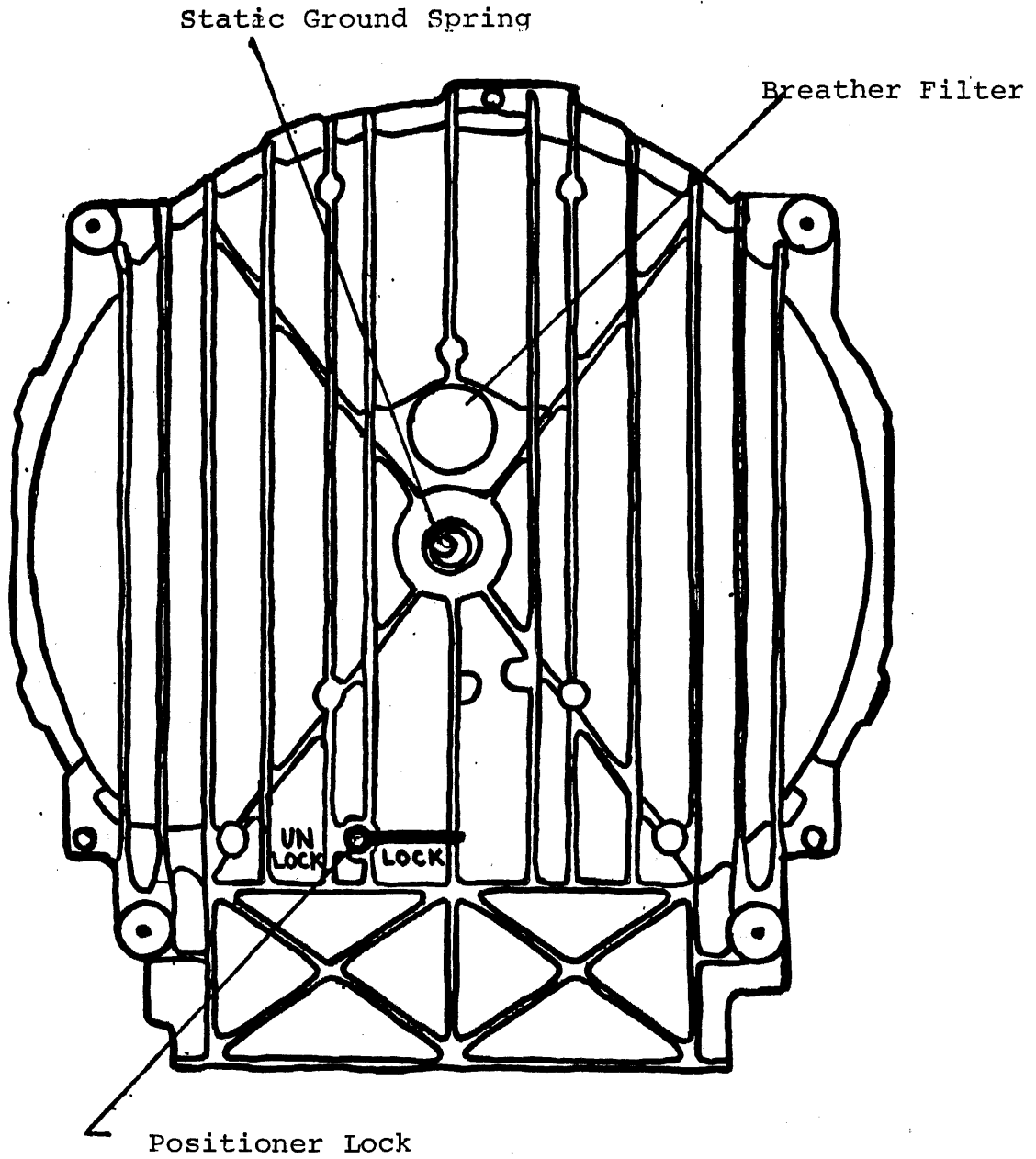

Operator Control Panel Fault Display Codes

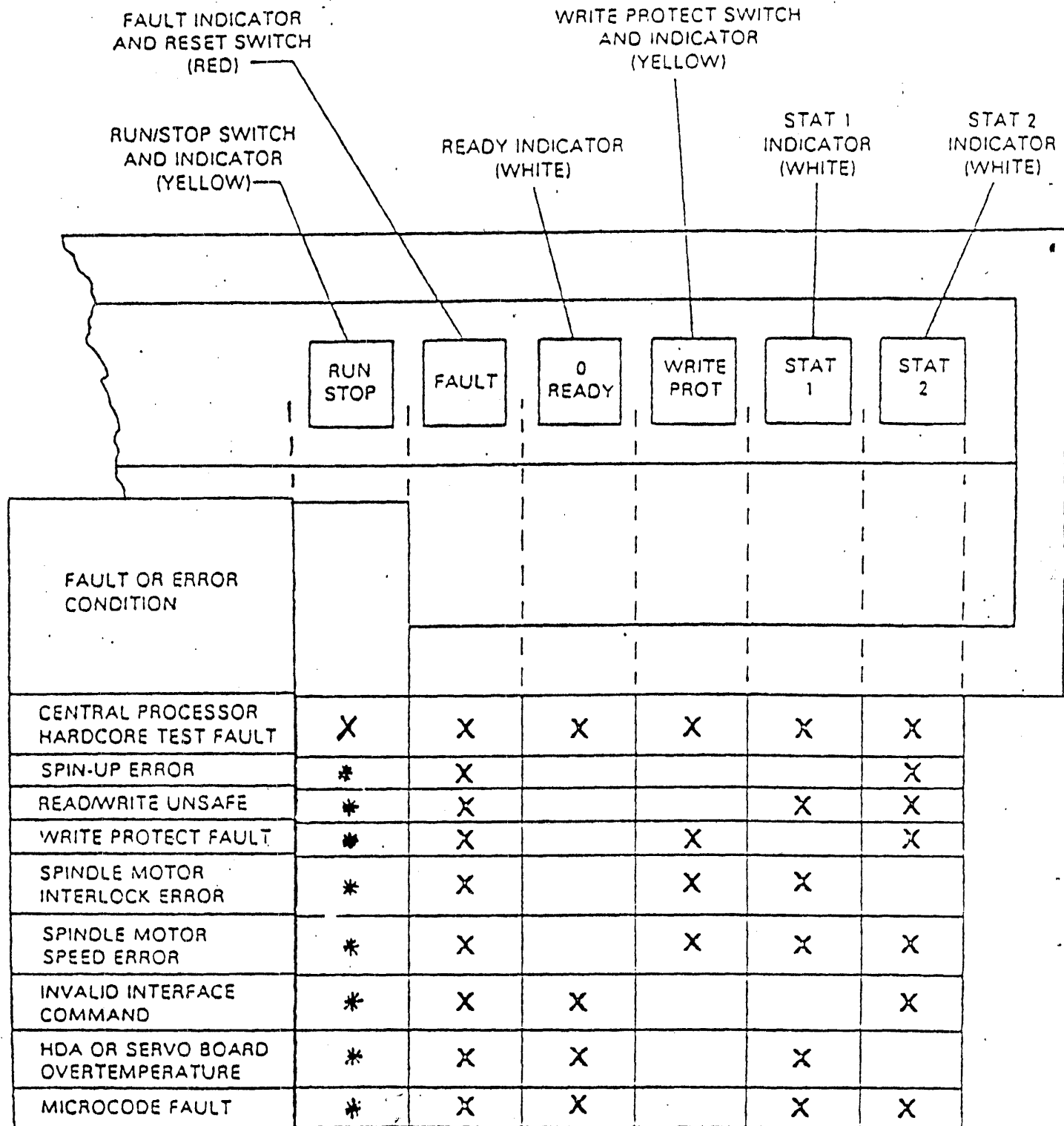

* The indicator state will be the same as it was before the FAULT switch was pushed.

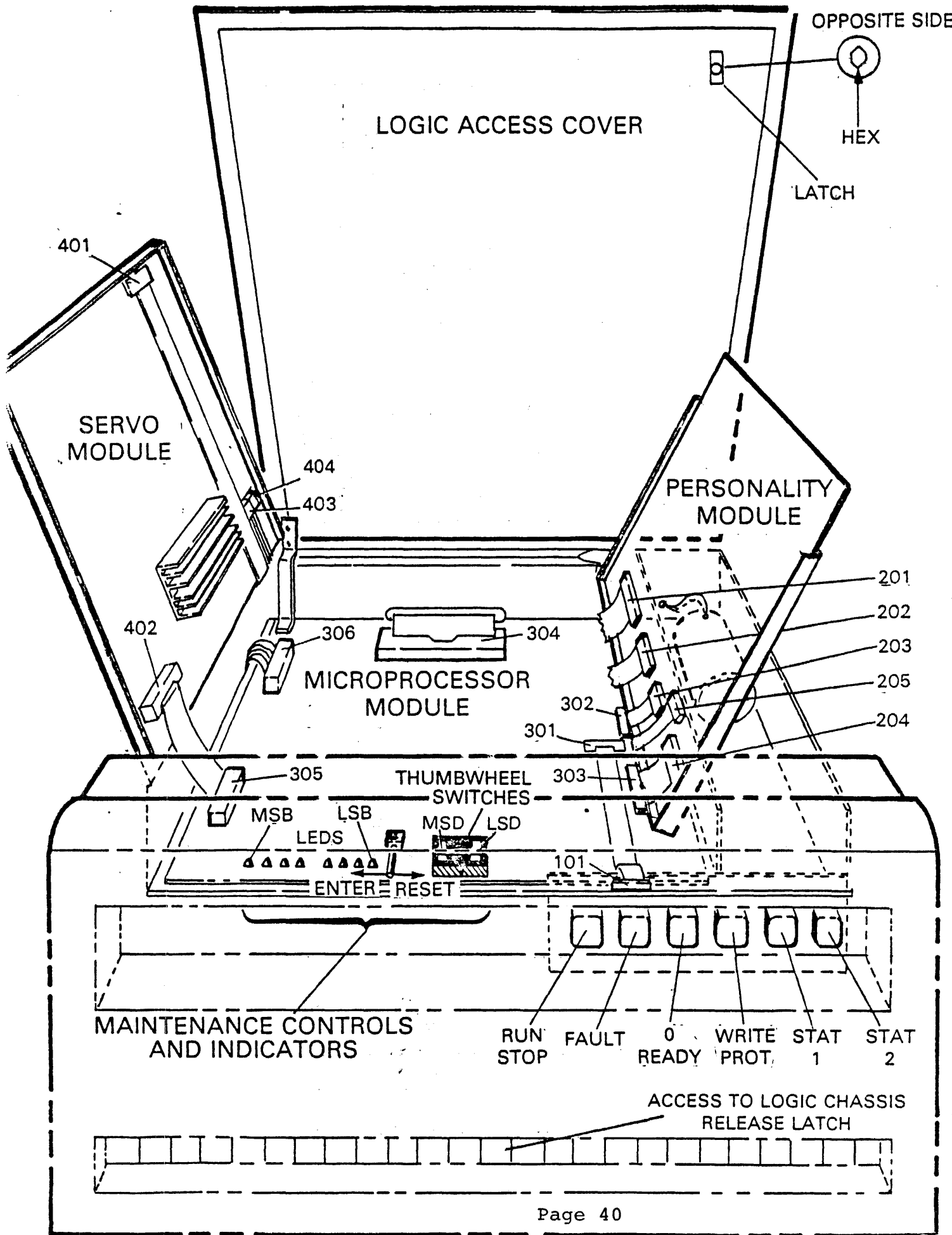

RM02/03 Documentation

RM02 Disk Drive Technical Manual - Volume I	(EK-1RM02-TM)*
RM02 Disk Drive Technical Manual - Volume II (RM02 Print Set)	(EK-2RM02-TM)
RM03 Disk Drive Technical Manual - Volume I	(EK-1RM03-TM)*
RM03 Disk Drive Technical Manual - Volume II (RM03 Print Set)	(EK-2RM03-TM)
RM02/03 Disk Subsystem User's Guide	(EK-RM03-UG)
RM02/03 Adapter Technical Description Manual	(EK-RM023-TD)*
RM02 Disk Subsystem Illustrated Parts Breakdown	(EK-RM02-IP)*
RM03 Disk Subsystem Illustrated Parts Breakdown	(EK-RM03-IP)*
RM02 Field Maintenance Customer Print Set (Adapter Print Set)	(MP-00456)
RM03 Field Maintenance Customer Print Set (Adapter Print Set)	(MP-00350)

*These documents are also available on microfiche. Order as EP-XXXXX-XX.

<u>DEC #</u>	<u>Title</u>
EK-ORM80-TD-001	RM80 Disk Drive Technical Description Manual
EK-0RM80-PG	RM80 Pocket Service Guide
EK-0RM80-UG	RM80 Disk Drive User's Guide
EK-ORM80-IP	RM80 Disk Drive Illustrated Parts Breakdown
MP-00875	RM80 Disk Drive Field Service Maintenance Print set
EK-RM80-SV	RM80 Disk Drive Service Manual
	RM80 Disk Drive Technical Manual
EP-RMADA-TD	RM Adapter Technical Description Manual

Supporting Documentation for RH70 & RH780

EK-RWP04-MM	RWP04 Disk Subsystem Maintenance Manual
EY-D3038-SP	RH11/RH70 MASSBUSS Controllers Self-Paced Course
EK-RH780-TD	RH780 Technical Description Manual
EK-DS780-UG	VAX 11/780 Diagnostic System User's Guide

RM02/03/05/80 Documentation

Title	Dec Part Number
RM05 Disk Drive User's Guide (Ships with the drive)	EK-ORM05-UG
RM05 Disk Drive Service Manual	EP-ORM05-SV *
RM05 Disk Drive Maintenance Print Set (Ships with the drive.)	MP-01075
BK7B1E/F Disk Drive Maintenance Print Set	ER-BK7B1-MP
RM05 Disk Drive Illustrated Parts Breakdown	EP-0016A-IP *
BK7B1E/F Disk Drive Illustrated Parts Breakdown	ER-BK7B1-IP
BK7B1E/F Disk Drive Technical Description	ER-BK7B1-TD *
RM Massbus Adapter Technical Description	EK-RMADA-TD *

*Available on micro-fiche, order as EP-XXXXX-XX except the RM05 IPB which is EP-ORM05-IP.

With the introduction of the 50 Hz RM05 and the new power supplies, some of the above documentation may be changed or added to.

RM02/03 Specifications

Specification	Limit	
Seek Time	RM03	RM02
Maximum seek (822 cylinders)	55 ms	55 ms
One cylinder seek (maximum)	6 ms	6 ms
Average seek	30 ms	30 ms
Seek to the same cylinder	37.5 μ s	37.5 μ s
Latency		
Speed	3600 rev/min	2400 rev/min
Maximum latency	17.3 ms	25.9 ms
Average latency	8.33 ms	12.5 ms
Start/Stop time		
Start (maximum)	35 s	25 s
Start (typical)	25 s	15 s
Stop (with power) (maximum)	35 s	20 s
Stop (with power) (typical)	25 s	10 s
Stop (without power)	120 s	60 s
Heads		
Servo head	1	1
Read/write heads	5	5
Data Rates		
Bit cell time	103.3 ns	155.0 ns
Word rate (16-bit)	1.65 μ s	2.48 μ s
Word rate (18-bit)	1.86 μ s	2.79 μ s
Bit rate	9.677 MHz	6.45 MHz
No. of Addressable Registers in RM02/03 Adapter	16	16
Error Detection/Correction	32-bit ECC/sector	32-bit ECC/sector
Time for Correction	4.47 ms, maximum	5.96 ms, maximum
Environmental Limits		
Temperature		
Operating	15.0° to 32.2° C (59° to 90° F) with a maximum gradient of 6.7° C (12° F) per hour.	
Non-operating	-40° to 66° C (-40° to 151° F) with a maximum gradient of 14° C (25° F) per hour.	

RM02/03 Specifications (Cont)

Specification	Limit	
Relative humidity Operating	20 to 80 percent (providing there is no condensation)	
Non-operating	5 to 95 percent (providing there is no condensation)	
Altitude Operating	305 m (1000 ft) below sea level to 2000 m (6500 ft) above sea level.	
Non-operating	305 m (1000 ft) below sea level to 4572 m (15,000 ft) above sea level.	
Electrical	RM03	RM02
Voltages available (single-phase)	100 Vac +10, -10; 60 Hz	100Vac +10, -10; 60 Hz
	120 Vac +8, -18; 60 Hz	120 Vac +8, -18; 60 Hz
	240 Vac +17, -27; 50 Hz	240 Vac +17, -27; 50 Hz
Start current for:		
100 Vac, 60 Hz	33 A rms, maximum	TBS
120 Vac, 60 Hz	30 A rms, maximum	TBS
240 Vac, 50 Hz	22 A rms, maximum	TBS
100 Vac, 50 Hz	33 A rms, maximum	TBS
Line current		
Disk and carriage in motion	Total	Total
100 Vac, 60 Hz	11 A rms	TBS
120 Vac, 60 Hz	11 A rms	TBS
240 Vac, 50 Hz	7 A rms	TBS
100 Vac, 50 Hz	14 A rms	TBS
In standby mode		
100 Vac, 60 Hz	4.5 A rms	TBS
120 Vac, 60 Hz	4.5 A rms	TBS
240 Vac, 50 Hz	3.5 A rms	TBS
100 Vac, 50 Hz	7 A rms	TBS
Line Cord Length	213.4 cm (7 ft)	213.4 cm (7 ft)
Plug Type		
100 V/60 Hz	NEMA 5-15 P	NEMA 5-15 P
120 V/60 Hz	NEMA 5-15 P	NEMA 5-15 P
240 V/50 Hz	NEMA 6-15 P	NEMA 6-15 P
100 V/50 Hz	NEMA 5-15 P	NEMA 5-15 P
Disk Cartridge Type	RM03P	RM03P

Table 1-8 RM03P Disk Pack Specifications

Specification	Limits
Type	9877 disk pack
Disk Diameter	35.56 cm (14 in)
Number of Disks	5 (the upper and lower disks are not used for recording)
Number of Recording Surfaces	5 read/write and 1 read-only servo surface
Cylinders per Disk Pack	823
Total Number of Tracks	4115 per disk pack
Tracks per Cylinder	5
Bad Sector File	Cylinder 822, track 4
Environmental Requirements	
Temperature range (operating)	10° to 57° C (50° to 135° F); temperature change rate not to exceed 0.1° C (0.2° F) per minute.
Temperature range (non-operating)	-40° to 65° C (-40° to 150° F); temperature change rate not to exceed 14° C (25° F) per hour.
Relative Humidity	
Operating and non-operating	8 to 80 percent
Wet Bulb Reading	
Operating	25° C (78° F), maximum
Non-operating	30° C (85° F), maximum
Altitude	
Operating	Mean sea level to 3050 m (10,000 ft)
Non-operating	Mean sea level to 12,190 m (40,000 ft)
Stray magnetic fields	
Operating and non-operating	Not to exceed 50 oersteds

RM02/RM03 OPTIONS

The RM02/03 options are specified, according to their power requirements and their number of access ports. Table 1-9 shows what options are currently available.

RM02/03 Options	
RM02/03 Single-Port Options	
RM02-AA or RM03-AA	120 V/60 Hz
RM02-AD or RM03-AD	240 V/50 Hz
RM02-AE or RM03-AE	100 V/60 Hz
RM02-AF or RM03-AF	100 V/50 Hz
RM02/03 Dual-Port Options	
RM02-BA or RM03-BA	120 V/60 Hz
RM02-BD or RM03-BD	240 V/50 Hz
RM02-BE or RM03-BE	100 V/60 Hz
RM02-BF or RM03-BF	100 V/50 Hz

NOTE

A single-port drive is field-upgradable to dual-port capabilities.

RM03P Pack Capacity Allocation

Data Word Format	18-Bit Format	16-Bit Format
No. of Sectors/ Data Track	30 sectors	32 sectors
Bits/Sector	5,376 bits/sector	4,864 bits/sector
Total Formatted Capacity (See Note 1.)	663,667,200 bits/pack	640,491,520 bits/pack
Formatted Data (See Note 2.)	568,857,600 data bits/pack	539,361,280 data bits/pack
Total Number of Words (See Note 3.)	31,603,200 words/pack	33,710,080 words/pack

NOTES

- $(\text{Bits/sector}) \times (\text{sectors/track}) \times (5 \text{ tracks/cylinder}) \times (823 \text{ cylinders/pack}) = \text{Bits/pack}$
- $(\text{Bits/data word}) \times (256 \text{ words/sector}) \times (\text{sectors/track}) \times (5 \text{ tracks/cylinder}) \times (823 \text{ cylinders/pack}) = \text{Formatted data word bits/pack}$
- $(\text{Formatted data word bits}) \div (\text{bits/word}) = \text{Words/pack}$

DRIVE SPECIFICATIONS

The RM05 Disk Drive must operate in a Class A computer room environment. Performance, power, environmental, and physical specifications for the drive are listed in Table 1-6. The specifications for the disk pack are provided in Table 1-7.

RM05 Specifications

Characteristic	Specification
Seek time	
Maximum seek (822 cylinder)	55 ms
One cylinder seek (maximum)	6 ms
Average seek	30 ms
Seek to the same cylinder	4 μ s
Latency	
Speed	3600 r/min
Maximum latency	17.3 ms
Average latency	8.33 ms
Start/stop time	
Start (maximum)	35 s
Start (typical)	25 s
Stop (with power) (maximum)	35 s
Stop (with power) (typical)	25 s
Stop (without power)	120 s
Heads	
Servo head	1
Read/write heads	19
Data rates	
Bit cell time	103.3 ns
Word rate	1.65 μ s
Number of addressable registers in RM05 adapter	16
Error detection/correction	32-bit ECC/sector
Time for error correction	4.47 ms, maximum

RM05 Specifications (Cont)

Characteristic	Specification
Environmental limits	
Temperature	
Operating:	15.0° to 32.2° C (59° to 90° F) with a maximum gradient of 6.7° C (12° F) per hour.
Non-operating:	-40° to 70.0° C (-40° to 158° F) with a maximum gradient of 20° C (36° F) per hour.
Relative humidity	
Operating:	20 to 80 percent (providing there is no condensation)
Non-operating:	5 to 95 percent (providing there is no condensation)
Altitude	
Operating:	305 m (1000 ft) below sea level to 2000 m (6500 ft) above sea level
Non-operating:	305 m (1000 ft) below sea level to 4572 m (15,000 ft) above sea level
Electrical	
Voltages available (Drive)	208 V (+14.6, -29.0), 60 Hz 230 V (+14.5, -32.0), 60 Hz 220 V (+15.0, -25.0), 50 Hz 240 V (+17.0, -27.0), 50 Hz
Voltages available (Adapter)	120 V (+8.0, -8.0), 60 Hz 220 V (+15.0, -25.0), 50 Hz 240 V (+17.0, -27.0), 50 Hz
Start current	208 Vac, 60 Hz @ 39.0 A rms max 230 Vac, 60 Hz @ 40.0 A rms max 220 Vac, 50 Hz @ 40.0 A rms max 240 Vac, 50 Hz @ 41.0 A rms max

RM05 Specifications (Cont)

Characteristic	Specification
Line current	
Disk and carriage in motion	208 Vac, 60 Hz @ 8.0 A rms max 230 Vac, 60 Hz @ 7.2 A rms max 220 Vac, 50 Hz @ 9.5 A rms max 240 Vac, 50 Hz @ 8.7 A rms max
Disk not in motion	208 Vac, 60 Hz @ 2.0 A rms max 230 Vac, 60 Hz @ 1.8 A rms max 220 Vac, 50 Hz @ 2.5 A rms max 240 Vac, 50 Hz @ 2.3 A rms max
Adapter	120 Vac, 60 Hz @ 2.1 A rms max 220 Vac, 50 Hz @ 1.3 A rms max 240 Vac, 50 Hz @ 1.4 A rms max
Line cord length	366 cm (12 ft)
Disk cartridge type	RM05P
Weight	
RM05 drive and cabinet	249 kg (550 lbs)
Adapter cabinet	54 kg (120 lbs)
With one adapter	91 kg (200 lbs)
With two adapters	127 kg (280 lbs)
AC plug types	
RM05 drive	
120 volt 60 Hz	NEMA L6-20P
208 volt 50 Hz	Not shipped
Adapter	
120 volt 60 Hz	NEMA 5-15P
208 volt 50 Hz	NEMA 6-15P

RM05P Disk Pack Specifications

Characteristic	Specification
Disk Diameter	35.56 cm (14 in)
Number of disks	12 (the upper and lower disks are not used for recording)

RM05P Disk Pack Specifications (Cont)

Characteristic	Specification
Number of recording surfaces	19 read/write and one read-only servo surface
Cylinders per disk pack	823
Total number of tracks	15,637 per disk pack
Tracks per cylinder	19
Tracks per inch	384
Bad sector file	Cylinder 822, track 18
Environmental requirements	
Temperature range	
Operating:	10° to 57° C (50° to 135° F); temperature change rate not to exceed 0.1° C (0.2° F) per minute
Non-operating:	-40° to 65° C (-40° to 150° F); temperature change rate not to exceed 14° C (25° F) per hour
Relative humidity	
Operating and non-operating:	8 to 80 percent
Wet bulb reading	
Operating:	25° C (78° F), maximum
Non-operating:	30° C (85° F), maximum
Altitude	
Operating:	Sea level to 3,050 m (10,000 ft)
Non-operating:	Sea level to 12,190 m (40,000 ft)
Stray magnetic fields	
Operating and non-operating:	Not to exceed 50 oersteds

Drive Power Consumption Requirements

Input Voltage	Unit Status	Line * Current	Consumption *		Power Factor
			Kw	BTU/hr	
208 V, 60 Hz	Disks and carriage in motion	8.0 A	1.20	4200	.70
230 V, 60 Hz		7.2 A	1.20	4200	.70
220 V, 50 Hz		9.5 A	1.30	4200	.70
240 V, 50 Hz		8.7 A	1.30	4200	.70
208 V, 60 Hz	Disks not in motion	2.0 A	0.40	1400	.90
230 V, 60 Hz		1.8 A	0.40	1400	.90
220 V, 50 Hz		2.5 A	0.50	1750	.90
240 V, 50 Hz		2.3 A	0.50	1750	.90

*These are maximum values.

SECTION TWO
RM02/03/05 Checks
And Adjustments

- 1.) Remove AC power from the drive, diconnect the A and B cables running to the drive. Connect the A and B cables from the FTU to the drive. See figure 1.
- 2.) Install the HFSV card in the drive's logic chassis at location A02. See figure 2.
- 3.) Install the head alignment cable between the drive's logic backplane and the jack on the R/W module as specified in figure 3.
- 4.) Connect the test leads between the HFSV card and the null meter on the FTU panel. Observe polarity. See figure 2.
- 5.) Set switches on FTU as indicated in figure 4.
- 6.) Apply AC power to the drive.
- 7.) Turn on the FTU.
- 8.) Install CE pack, write protect the drive.
- 9.) Connect the oscilloscope to head alignment card test point Y.
- 10.) Make drive under test ready.

NOTE

In order to ensure accuracy during head alignment, it is important that the drive, CE pack, and FTU be at normal operating temperature. This requires that all three be connected and allowed to run for at least 60 minutes. If a second drive is to be aligned, then the stabilization period need only be 15 minutes for each additional drive.

- 11.) When the drive is up to speed and the ready light on the FTU panel is lit, momentarily actuate the initialize switch, the RTZ switch, and the reset switch on the FTU panel.
- 12.) Perform continuous seeks between cylinders 240₁₀ and 245₁₀ for 30 seconds minimum. This allows head gimbal springs to settle to a normal operating level.
 - a. Set the cylinder address to 240₁₀ on the FTU.
(Switches 16, 32, 64, 128 ON)
 - b. Set access mode switch to direct.
 - c. Momentarily depress the start switch.
 - d. Set the cylinder address to 245₁₀ (1, 4, 16, 32, 64, 128 ON)
 - e. Set the access mode switch to continuous.
 - f. Actuate start. The drive will perform continuous seeks between cylinders 240₁₀ and 245₁₀
- 13.) Stop seeks and command a direct seek to cylinder 245₁₀
 - a. Actuate the RTZ switch, then the reset switch on the FTU panel.
 - b. Set the cylinder address to 245₁₀
 - c. Set the access mode to direct.
 - d. Actuate start. The drive will seek to cylinder 245₁₀
- 14.) On the head alignment card in A02, set the S/RW switch to the 'S' position. Set X.1/X1 switch to X.1. See figure 2.

NOTE

When calculating head offset, if both P and N readings are less than 100 mV, set X.1/X1 switch on the head alignment card to X1 position. Return switch to the X.1 position before going on to the next head.

- 15.) Change the polarity of the alignment signal to the null meter with P/N switch. Record both the positive and the negative readings obtained. Use the following formula to calculate head offset: $(P) - (N) = \text{OFFSET}$. Example: P = +30 mV and N = -40 mV. The offset therefore equals 70 mV. Servo offset must be less than ± 30 mV. If not, you have a problem in the servo system.

- 17.) On the head alignment card in slot A02, set the S/RW switch to RW.
- 18.) Select head 0. Calculate and record offset.
- 19.) Repeat previous step for all remaining heads.
- 20.) If calculated offset for any head exceeded 100 mV then proceed to the Head Alignment.

NOTE

Any time you have to align the servo track or have heads which are severely out of alignment, you must back up the customer's data pack for the drive.

HEAD ALIGNMENT

- 1.) Stop the drive and turn off the AC breaker.
- 2.) Remove the head connector support bracket from the head-arm connector.
- 3.) Loosen head mounting screw for any head that exceeded the offset specification. Retighten each loosened screw to a torque of 6 in.lbs. See figure 6.
- 4.) Do steps 11 thru 13 of the head check procedure.

WARNING

Install alignment track locking pin into the align track hole. See figure 6. Failure to do so could cause personal injury. Any attempt to retract the heads with the locking pin installed will blow a 6A 250V fuse in the -42 Volt power supply. If this happens, you must manually unload the heads off of the CE pack before powering down the drive.

- 5.) GND backplane cylinder A2B09-03B (-On Cylinder) to prevent nuisance errors.
- 6.) Adjust head for balanced dibit pattern. See figure 7.
- 7.) Using the FTU meter, adjust the head until the minimum amount of offset is obtained. If the offset cannot be brought to less than 100 mV, you are probably at the end of travel on this head and will have to reposition the servo head. Any change in the servo head will require a complete alignment of all heads.
- 8.) While changing the P/N switch, continue to adjust the head until calculated offset is less than 100 mV.
- 9.) Set the switch on the head alignment card to the X1 position.
- 10.) Adjust the head to the smallest possible offset obtainable.
- 11.) On head alignment card, set the X.1/X1 to the X.1 position.
- 12.) Repeat steps 5 thru 9 for all heads to be aligned.
- 13.) Remove locking pin and jumper on backplane.
- 14.) Unload heads.
- 15.) Torque head mounting screws to $12 + \frac{1}{2}$ in.lbs.
- 16.) Do a head alignment check to see that all heads are within specifications.

Pin 60 - Black
 Pin 30 - Orange
 Pin 31 - Black
 Pin 01 - Brown

31	A CABLE	60
01		30

Red Stripe here

14	B CABLE	26
01		13

CARD CAGE FROM REAR

Figure 1 - Tester Cable Connection

Figure 2

Head Alignment Card

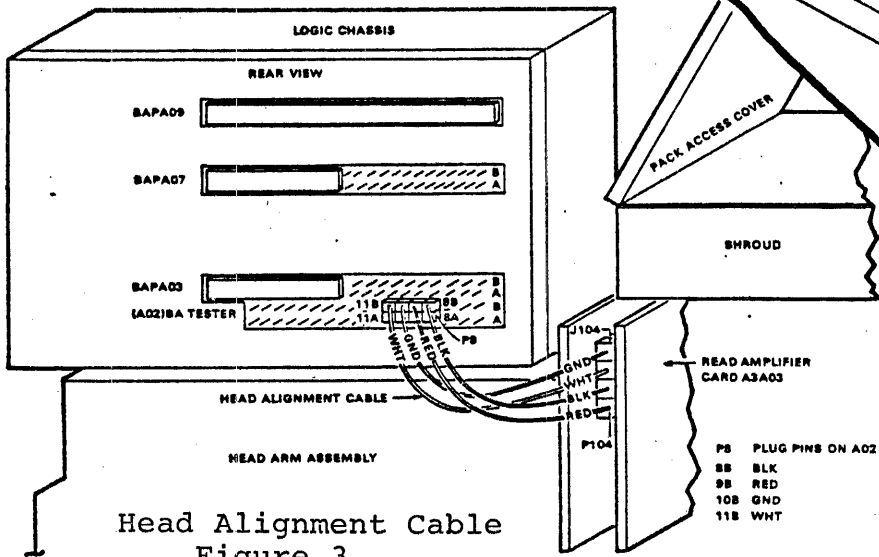
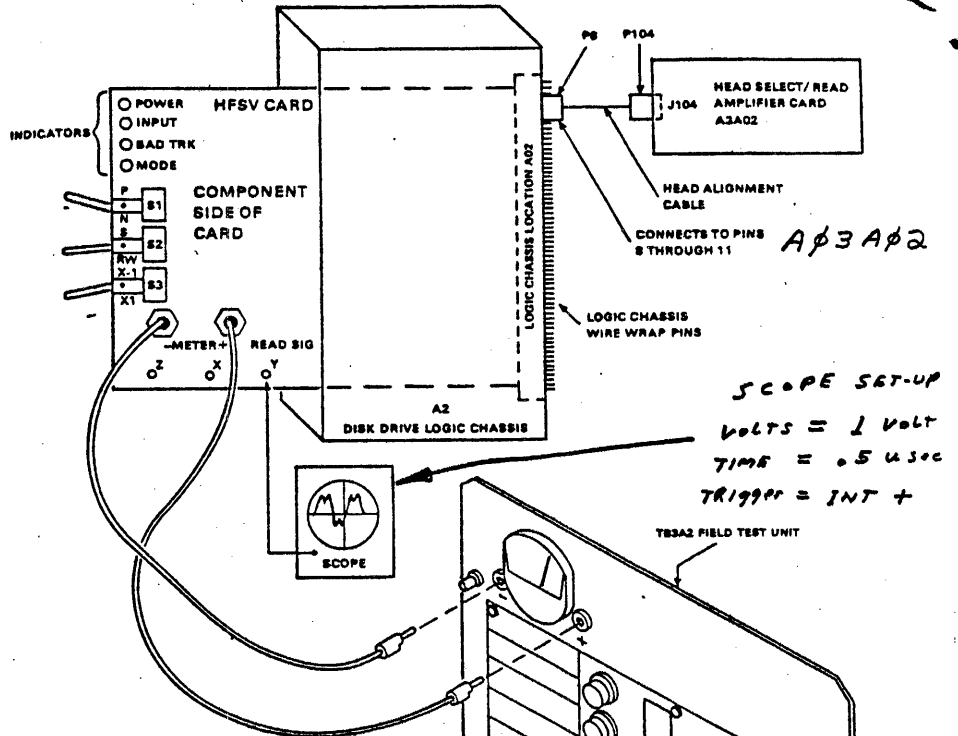

Head Alignment Cable
 Figure 3

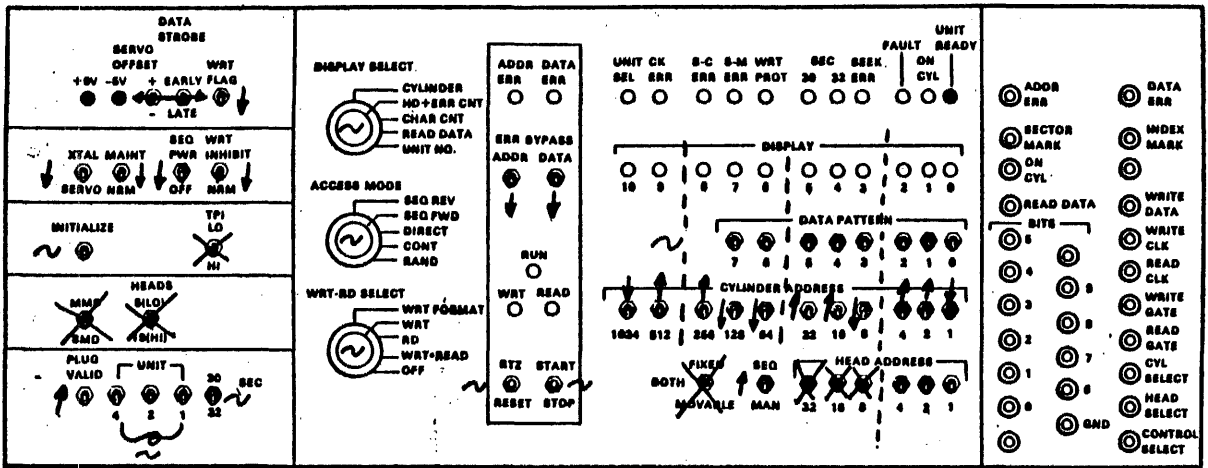

"A" INITIAL TESTER SET UP

MAX CYLINDER ADDRESS

- ↔ = CENTER
- ↓ = DOWN
- ↑ = UP
- ~ = AS REQUIRED
- X = DOES NOT MATTER

$$1466_8 = 822_{10}$$

Figure 4 - FTU

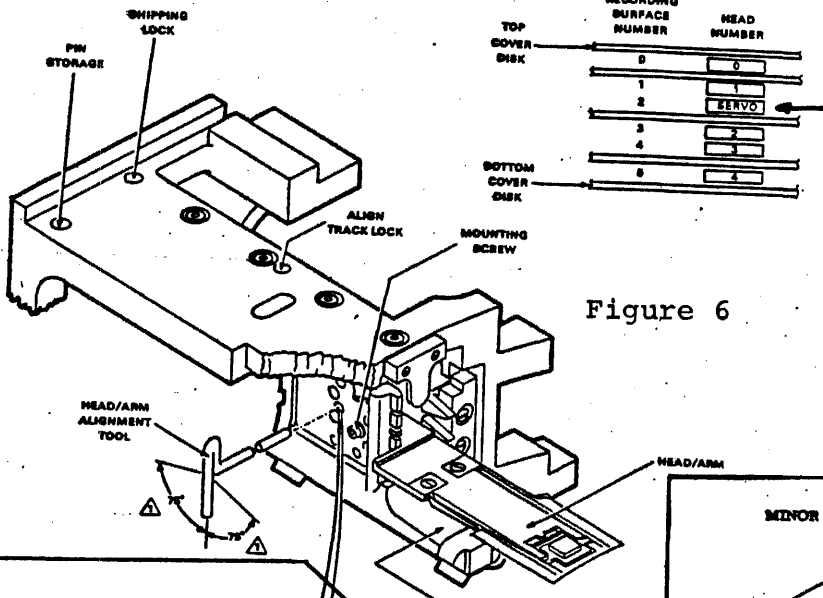
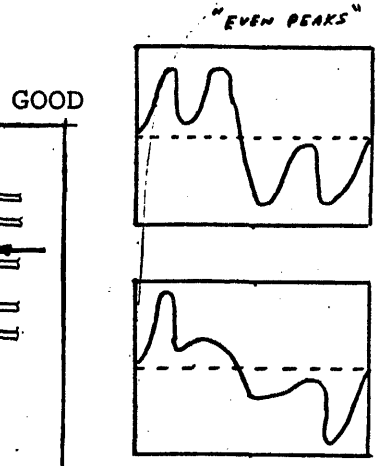

Figure 6



Out of Alignment

Figure 7

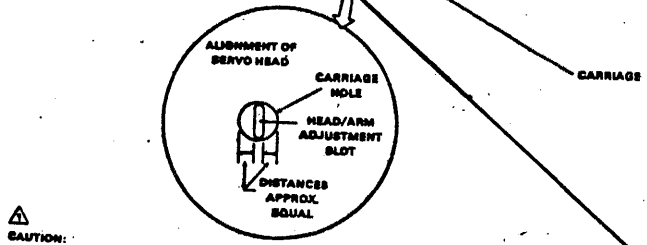
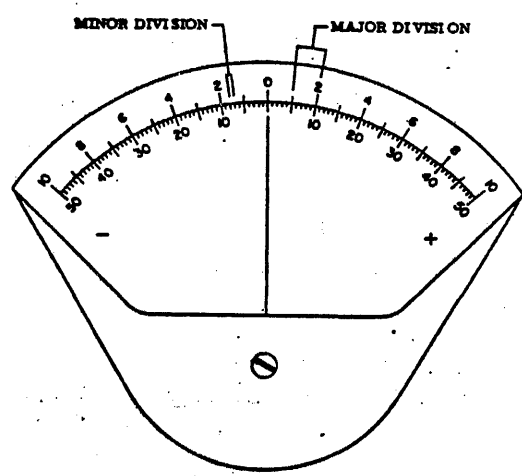

Figure 8



USE THE UPPER SCALE (0-10) ONLY, DISREGARD LOWER (0-50) SCALE
 X: 1: EACH MINOR DIVISION = 20 mV (FULL SCALE = 1000 mV)
 XI: EACH MINOR DIVISION = 2 mV (FULL SCALE = 100 mV)

Figure 5

RM02/03 INDEX TO BURST AND HEAD SCATTER MEASUREMENTS

Equipment needed:

By:Greg Ekholm

- RM02/03 CE pack
- 3 Scope probes with grounds
- Scope with .5 uS per division or better
- 4" jumper wire to be used on CDC backplane pins
- Standard tools (screwdrivers, etc.)
- RM02/03 FTU (Field Test Unit)

Use this chart or something similar to track your measurements on each drive and keep it for future reference.

 DRIVE SERIAL # _____ CE PACK SERIAL # _____
 DRIVE SERIES CODE _____ DATE OF TEST _____
 HOUR METER READING _____ CUSTOMER _____

HEAD	Cylinder 10	Cylinder 200	Cylinder 300	Carriage Way
0	_____ uSec	_____ uSec	_____ uSec	_____ uSec
1	_____ uSec	_____ uSec	_____ uSec	_____ uSec
2	_____ uSec	_____ uSec	_____ uSec	_____ uSec
3	_____ uSec	_____ uSec	_____ uSec	_____ uSec
4	_____ uSec	_____ uSec	_____ uSec	_____ uSec
Head Scatter	_____	_____	_____	_____

- 1.) Connect the FTU to the 9762 drive under test. (RM02/03)
- 2.) Load a CE pack on the drive and start the drive. Be sure to write protect the drive. NOTE: this starts the stabilization period.
- 3.) Set up the scope as follows:

NAME	PROBE	CARD	TEST POINT	CROSS-REF.
-RAW DATA	CH#1	A3A02	F	263
+RAW DATA	CH#2	A3A02	G	263
INDEX	EXT TRIG	A2B08	C	182

Test point 'Z' = GND on A3A02 and A3A03 cards
 A2B08 = Access control and Index decode.
 A3A02 = HD select and Read amplifier.

Volts per division .5 Volts (.05 V with 10:1 probe)
 Time per division .5 uSec
 Sweep Add
 Channel #2 Invert
 Coupling AC
 Trigger External Positive

4.) Set up the tester as follows:

Write Inhibit On
 Access Mode Direct
 Wrt-Rd Select Read
 HD Select Manual

5.) Thermal stabilization should be at least 15 minutes.

Do a direct seek to cylinder 10.₁₀

6.) GND the 'READ ENABLE' line at A2A04 pin 13B on the backplane. Test points A and Z are GND and also pins 1A and 34A.

NOTE: Remove the jumper before you seek or you will get a fault.

7.) Position the INDEX pulse at time '0' and select HD '0' via the tester.

Record your readings and sequence thru the remaining heads, recording your readings each time.

8.) Remove the GND applied in step 6 and do a direct seek to cylinder 200.₁₀ (Switches 128, 64, 8 ON)

9.) Reapply the GND as in step 6 and sequence thru all the heads again, recording the readings as in step 7.

10.) Remove the GND as in step 8 and do a direct seek to cylinder 300.₁₀ (Switches 256, 32, 8, 4 ON)

NOTE: Do not try to seek beyond cylinder 330.₁₀

11.) Reapply the GND as in step 6 and sequence thru all the heads again, recording the readings as in step 7.

YOUR READINGS SHOULD LOOK SOMETHING LIKE THIS:

HEAD	CYL 10 ₁₀	CYL 200 ₁₀	CYL 300 ₁₀	ΔCarriage Way
0	3.7 uSec	3.6 uSec	3.5 uSec	-.2 uSec
1	2.4	2.2	2.1	-.3 uSec
2	2.5	2.2	2.0	-.5 uSec
3	3.9	4.0	4.1	+.2 uSec
4	3.4	3.3	3.3	-.1 uSec
Δ HEAD	—	—	—	—
SCATTER	3.9	4.0	4.1	-.5
	<u>-2.4</u>	<u>-2.2</u>	<u>-2.0</u>	<u>+.2</u>
	1.5	1.8	2.1	.7

12.) The present tolerances as defined by CDC for INDEX to BURST is:

4 ± 4 uSec for the 3600 RPM RM03

6 ± 6 uSec for the 2400 RPM RM02

This would give you a head scatter tolerance of 8 uSec on the RM03. This can be checked by taking the largest and the smallest number from each of the cylinders and subtracting the smaller from the larger. This number must not exceed 8.

Any carriage not meeting this INDEX to BURST may have the following:

- 1.) A spindle alignment problem.
- 2.) Ahead skewed to one side caused by one of the following:
 - a. Head seating problem to the carriage.
 - b. Head assembled wrong at the factory.
 - c. The carriage and coil head mounting surface being out of tolerance.
- 3.) An upper to lower rail alignment problem.

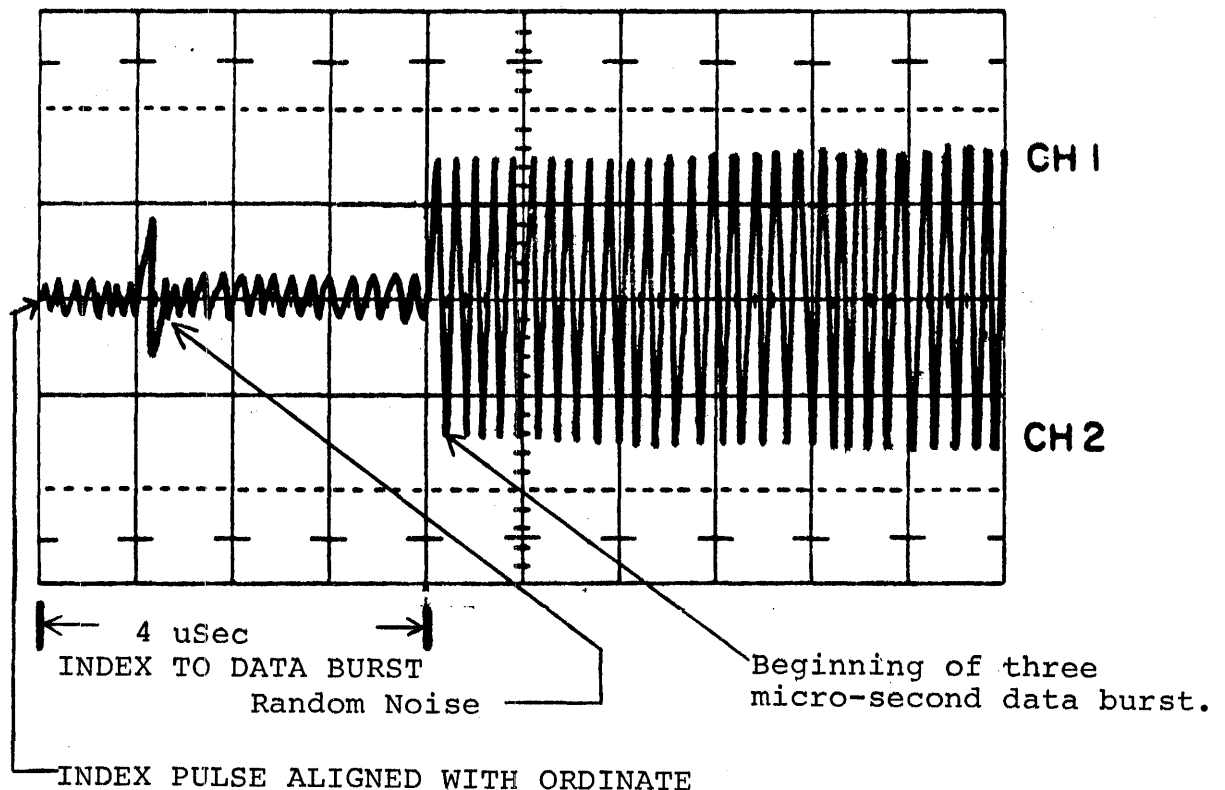

1. Check \pm 5 volt P.S. with DVM (repeat DVM) while doing 0-32 cylinder seeks
2. Back Plane ECO (70-13398-~~5~~-04) (F05C1 to F05C2)
3. W2 cut out of terminator/swapped
4. RM plugged into wall outlet dedicated 15A ckt (not 861)
5. Spindle ground cleaning
6. M7687 Bd plugged in good/straight
7. 2 drive system - plug MBA 0 to drive 1 and MBA 1 to drive 0
8. A2A04 fault latch card (Tech Tip)
9. A port out = input, A port in = output
10. Recheck \pm 5 volt power supply (RM02/3 Tech Tip #2)
11. Solder on Fast Tabs on Logic chassis (9762)
12. Velocity gain adjustment
13. MBA - Run diskless 1 and diskless 2
9762 - Run tester on drive
14. Loose connections on any cable? Servo pre-amp, logic cage, Berg Connectors or wires in Berg Connectors
15. "P"-clock? - Run extended drive test for seek timing
16. OPI's/seek incompletes/etc - check freeness of carriage and coil assy - clean rails
17. Header compare errors - recoverable on 2nd attempt - M7684 #12 Rev-CS-P
18. A and B cable 180° swap
19. Flex backplane MBA and 9762
20. Grds between MBA's/drives/CPU cabinet
21. W"1" Jumps on M7684 and M7685 Bds.
22. LCG Site? - Check jumper on MBA backplane E6E1 to E6C2. Must be in on 2020 sites. (BP144 ENBH)

Data Lates

Several articles and memos have been written about Data Lates on RM02/03. It is generally known that systems with RL01's, RL02's, RK06's, RK07's, RM02's and RM03's and combinations of these devices have the possibilities of having data lates. Listed below are some of the Sales Updates articles I could find on the subject.

Sales Update Vol. 9 Number 8 Page 9
 Vol. 9 Number 18 Page 15
 Vol. 9 Number 18 Page T12
 Vol. 11 Number 1 Page 3

As always, Sales Update articles are "Company Confidential" and therefore I have not reprinted them here.

Some of the best solutions to Data Lates are detailed as follows:

1. On PDP11/70's - Cache must be turned on.
2. MJ11-B core memory interleaved will be better than non-interleaved core memory.
3. RL11 controller Rev "L" or "M" reduced data lates over Rev "D" boards.
4. MJ11 controller have been shown to vary data lates between the same rev boards.
5. The version of DECX11 used affects data lates.
6. Buffer size used under DECX11 effects the frequency of data lates larger buffer = more data lates.
7. MOS memory interleaved has fewer data lates than core interleaved memory.
8. UNIBUS configuration is important and should be checked if data lates occur.

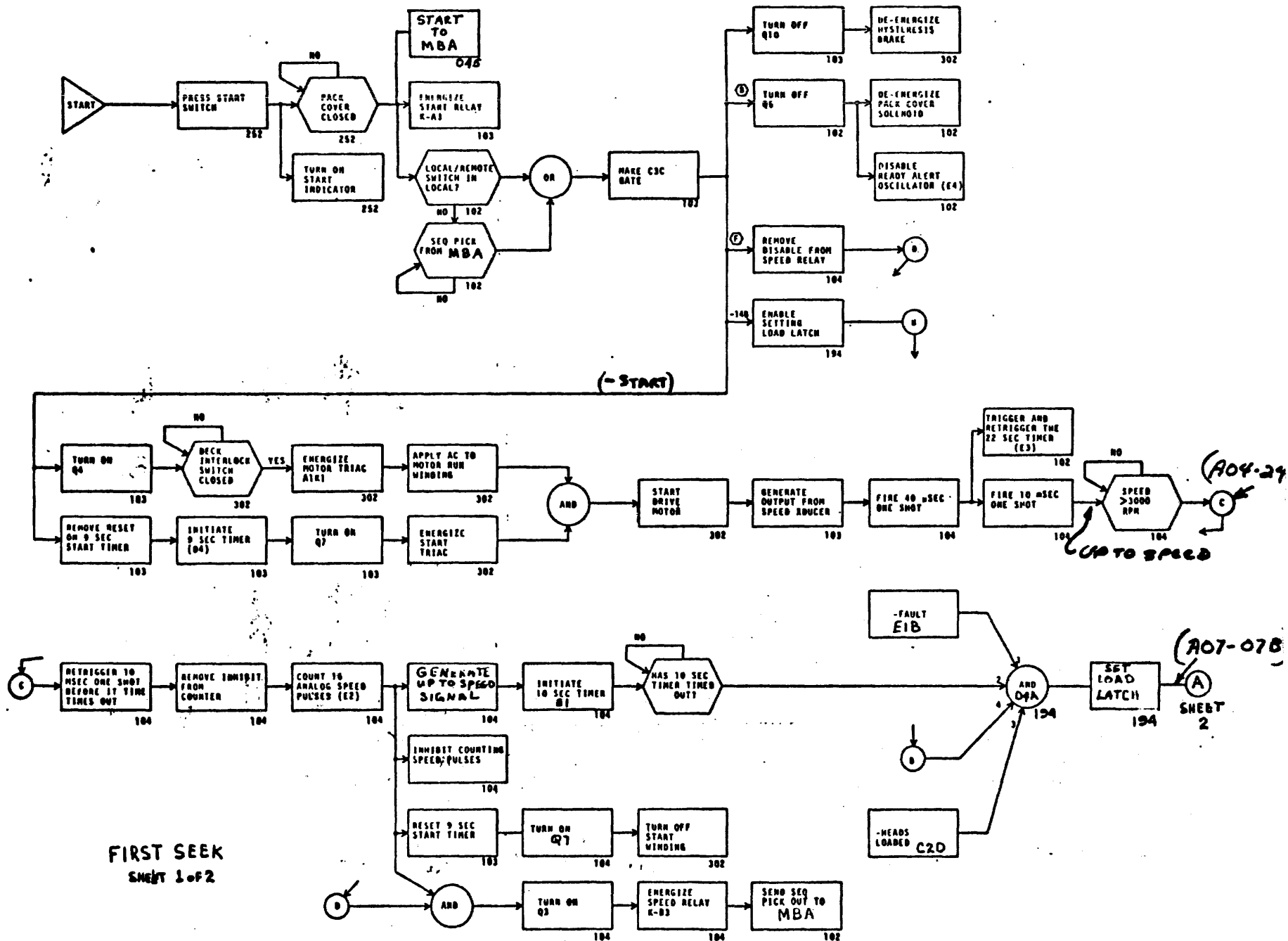

FIRST SEEK
SHEET 1 OF 2

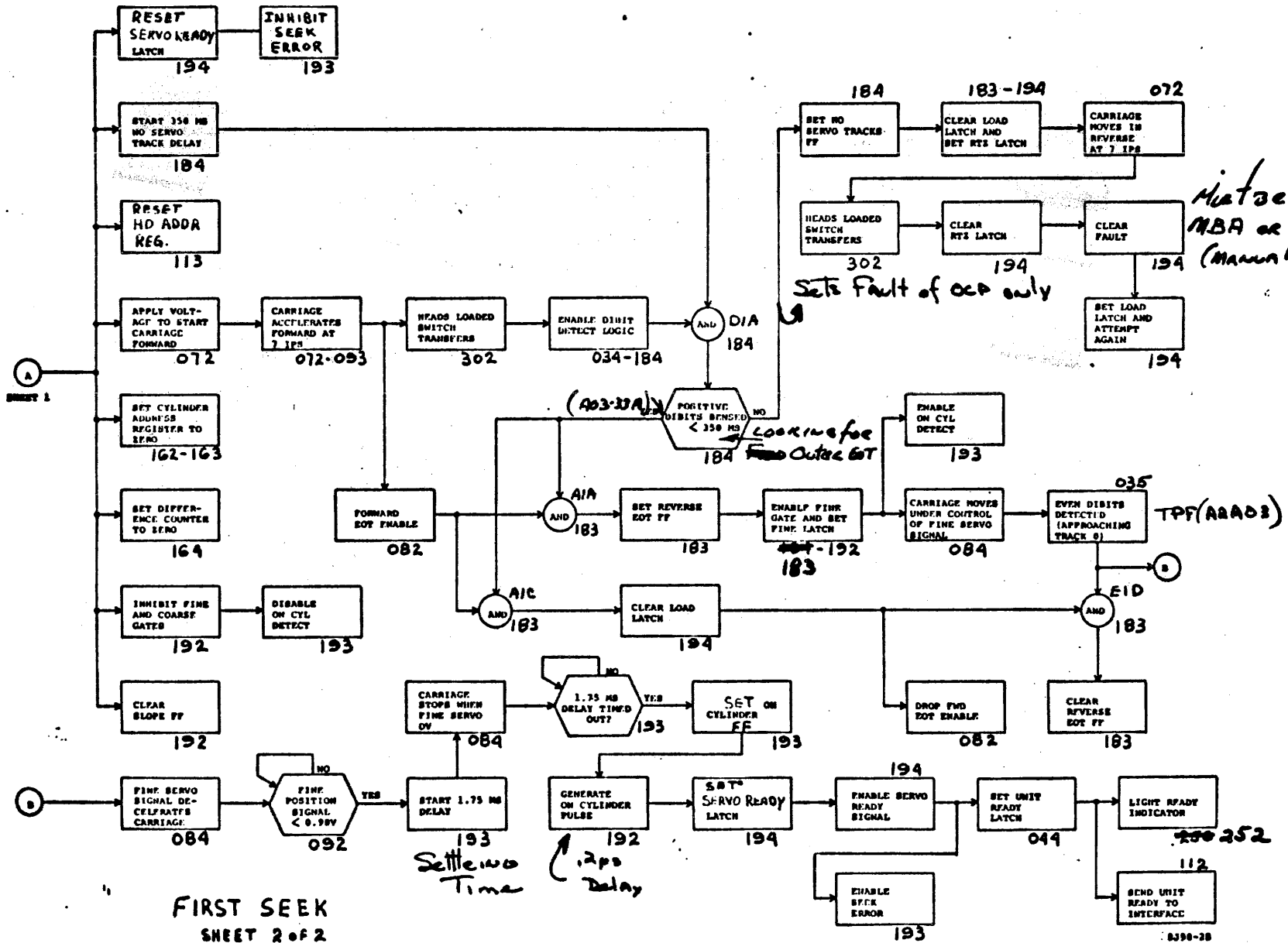

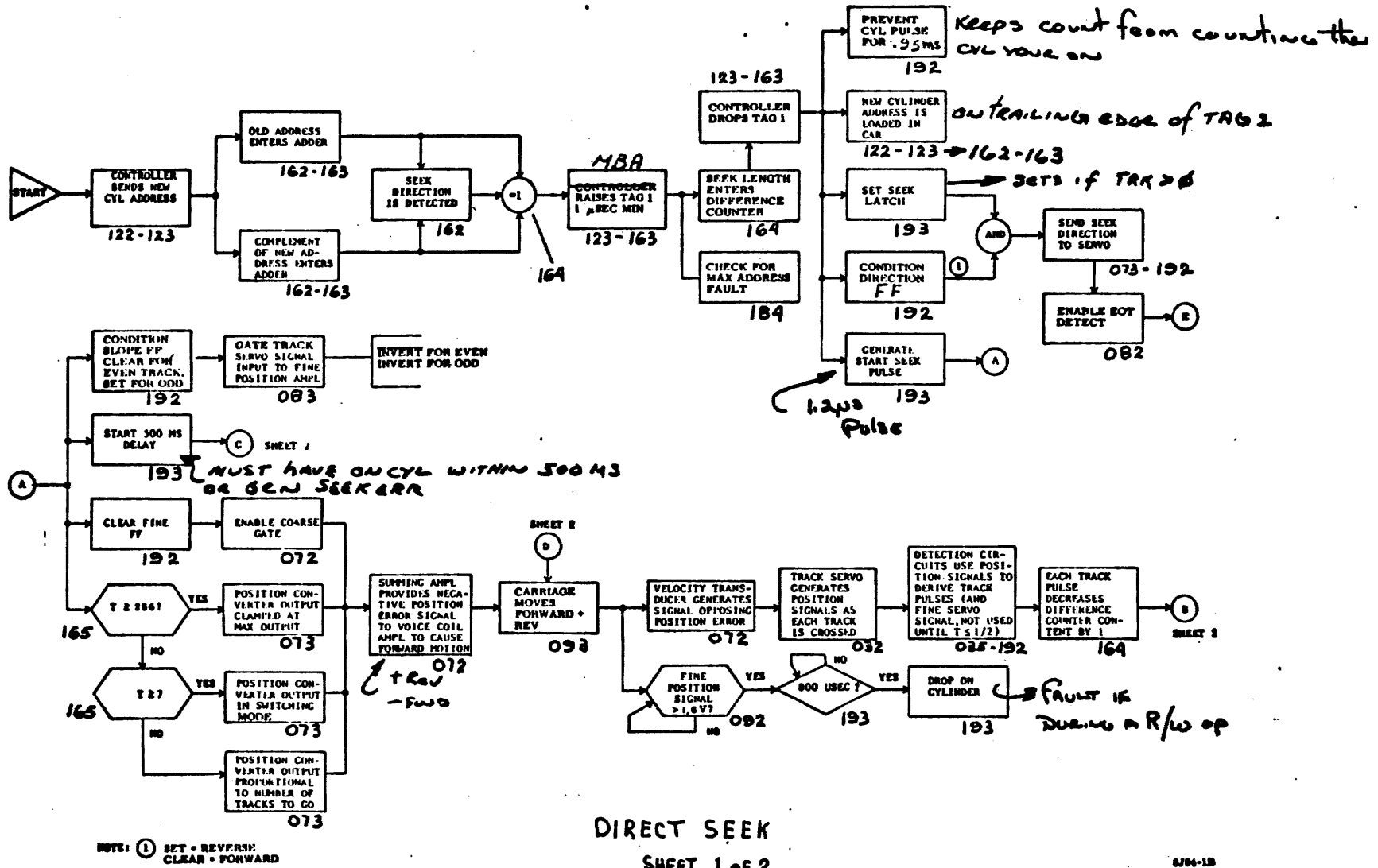

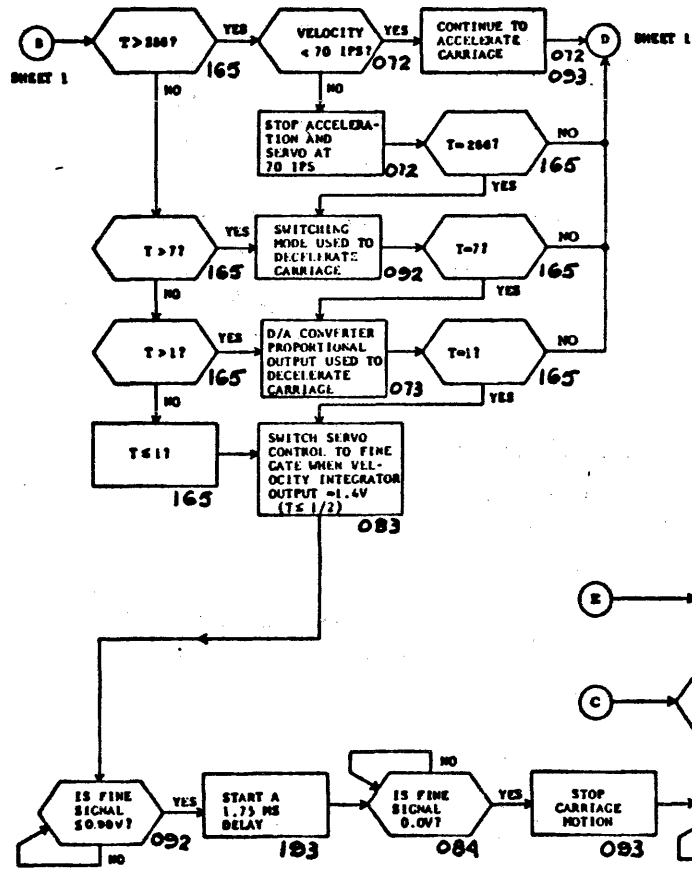

if Fwd EOT stops on Cyl 822
 if Rev " " " " 0
 goes to fine mode
 Resets Slope F/F
 Resets Diff Cate
 to zero

DIRECT SEEK

SHEET 2 OF 2

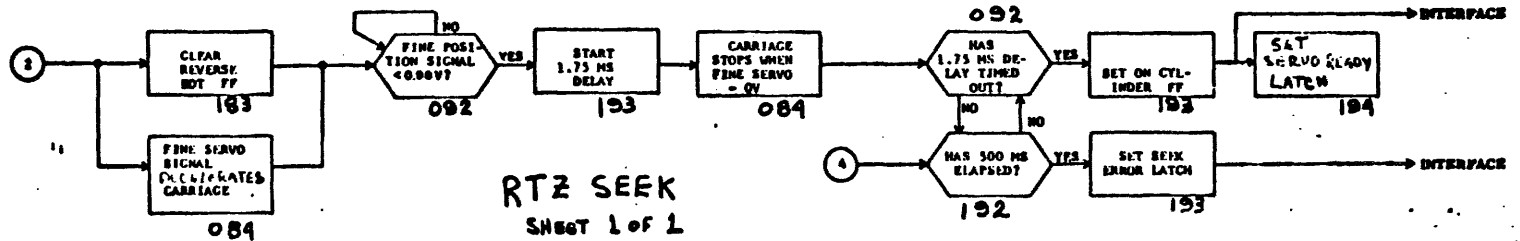
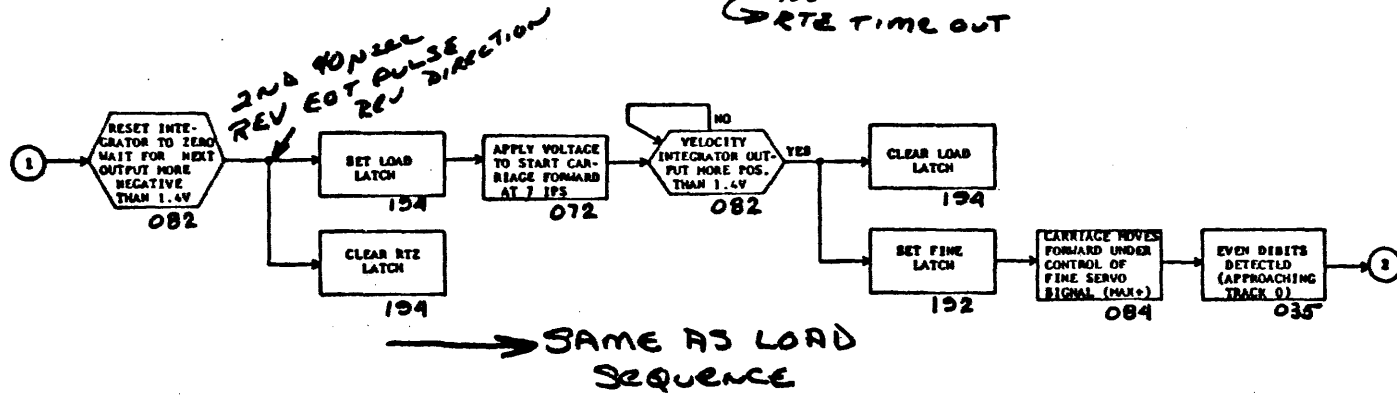
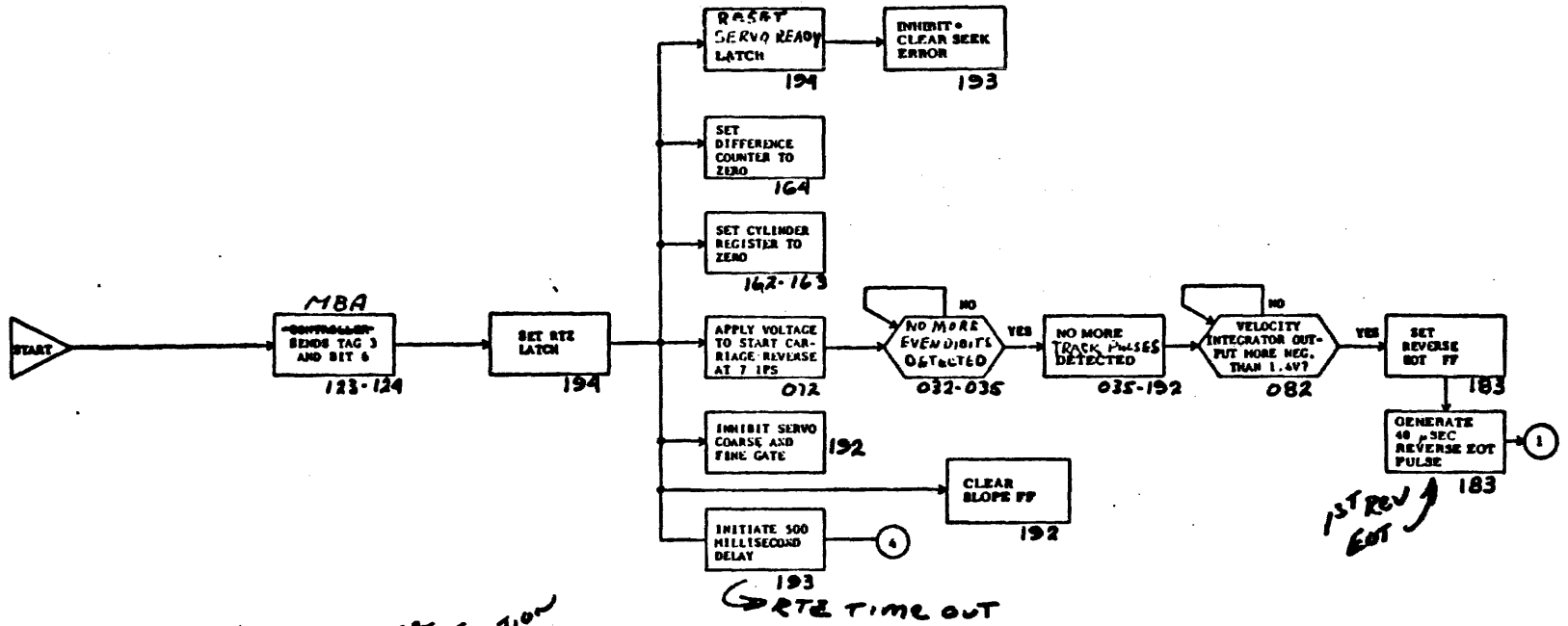

NOTES

RM05 SERVICE ADJUSTMENTS AND PROCEDURES

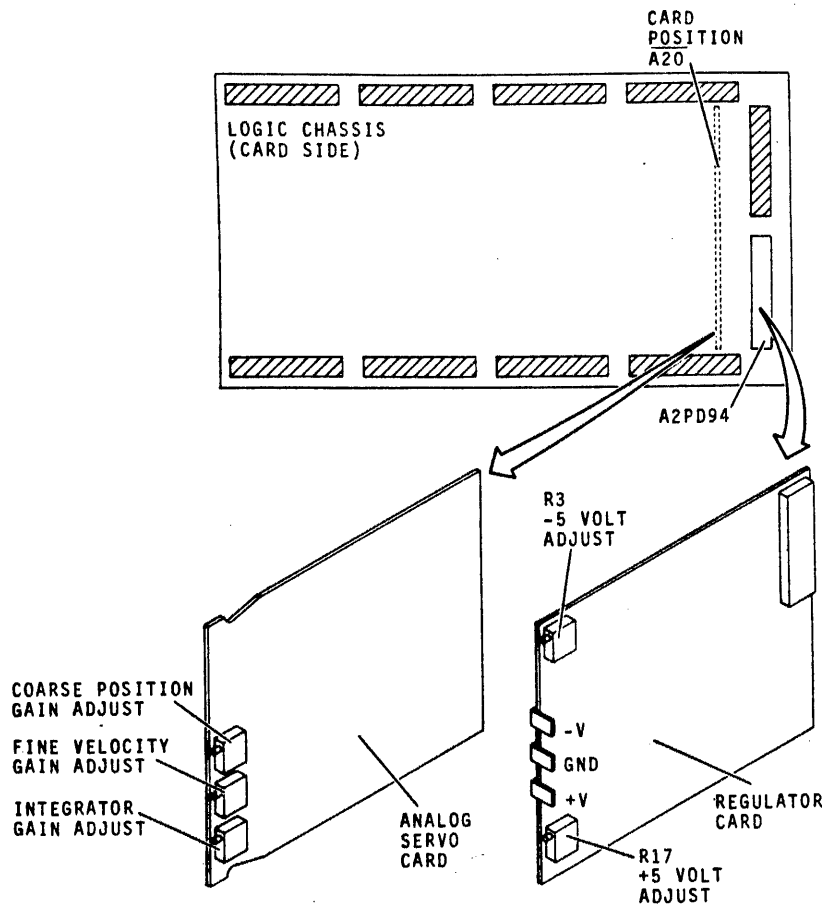

+5 Volt and -5 Volt Adjustments

- 1.) Using the FTU or hand toggle, command continuous seeks between cylinders 000 and 128.
- 2.) Connect positive voltmeter lead to A2JD94-04A on logic backplane. Connect negative lead to GND on the regulator card.
- 3.) Adjust +5 (R17) to measure +5.1 Volts (+0.05 V).
- 4.) Connect negative voltmeter lead to A2JD94-01A on logic backplane. Connect positive lead to GND on the regulator card.
- 5.) Adjust -5 (R3) to measure -5.1 Volts (+0.05 V).

Head Alignment Procedure

- 1.) Install head alignment card in logic rack A2. Connect FTU and meter leads.
- 2.) Mount CE pack on drive and allow it to thermally stabilize. CDC recommends that the pack be spinning with heads loaded for at least 60 minutes.

If the CE pack has just been removed from another drive which had been running for 60 minutes and the drive you are installing it on has been running for 60 minutes, then the recommended stabilization period is 15 minutes.

- 3.) Read the RM05 head alignment flow chart. Perform The servo head offset check.
- 3A.) Set the alignment card Servo/Read-Write switch to the Servo position. Set X.1/X1 to the X1 position.
- 3B.) Command continuous seeks between cylinders 360_g and 365_g for 30 seconds. Command a direct seek to cylinder 004_g.
- 3C.) Compare dibit pattern with example in this book. Toggle the Positive/Negative switch and record readings in both positions. Meter readings to the right of zero are positive and readings to the left of zero are negative. The positive value minus the negative value equals the amount off Offset.
Or... (P) - (N) = OFFSET.
- 3D.) If the amount of offset is outside the +60 mV range, there exists a problem in the servo system.
- 3E.) Next, command a direct seek to cylinder 005_g. Repeat steps 3C and 3D. Add offset readings from cylinders 004_g and 005_g. This sum should range between +75 mV and -75 mV. If it doesn't, you have a problem in the servo system.

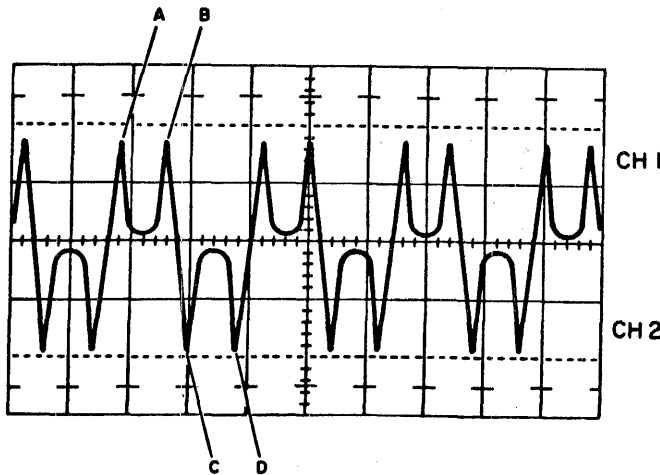

BALANCED DIBIT PATTERN

OSCILLOSCOPE
SETTINGS

CH1- 2 volts/div.
CH2- Not Used

Time Base
A- 2uS /div.
B- Not Used

Triggering
INTERNAL POSITIVE

CH1- Connected to
Dibits Test point
Y on alignment
card.

- 4.) Command a direct seek to cylinder 753_g. Install carriage locking pin into alignment hole.
- 5.) Set S/RW switch to the RW position. Calculate the offset of all read-write heads by the same method used in step 3C. If all offsets fall within the +150 mV range then the alignment is within spec.
- 6.) Any head that is greater than the +150 mV range is mis-aligned. If any head is +300mV offset, then back up the data pack for this drive before continuing to the head alignment. Remove alignment pin from drive.

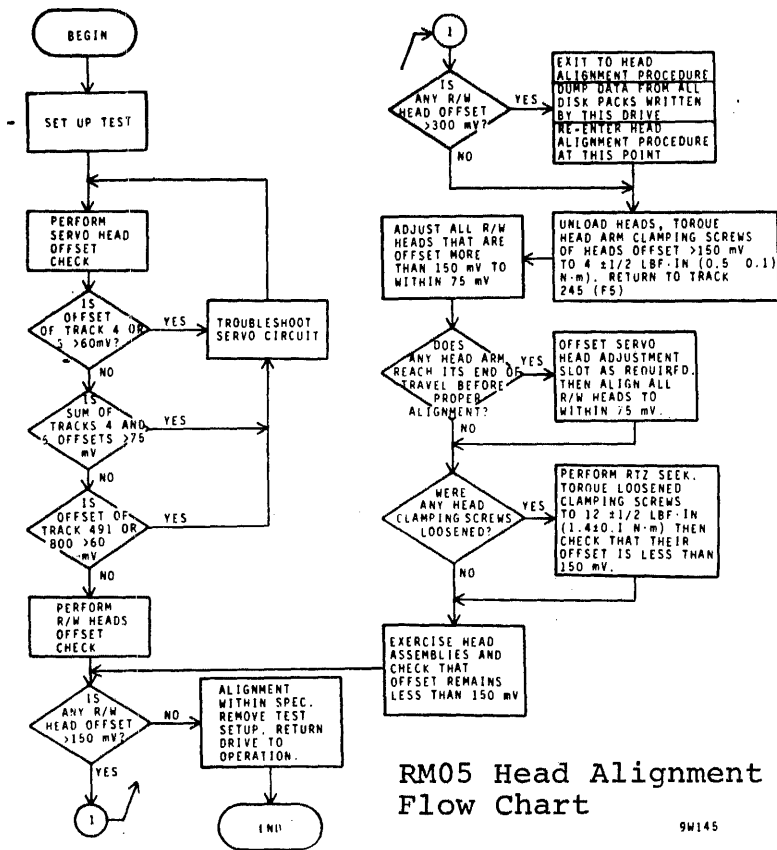

RM05 Head Alignment Flow Chart

9W145

DISK SURFACE NUMBER	HEAD-ARM NUMBER
	GUARD DISK
0	00
1	01
2	02
3	03
4	04
5	05
6	06
7	07
8	08
9	09
10	SERVO
11	10
12	11
13	12
14	13
15	14
16	15
17	16
18	17
19	18
	GUARD DISK

RM05 Head Arm Alignment

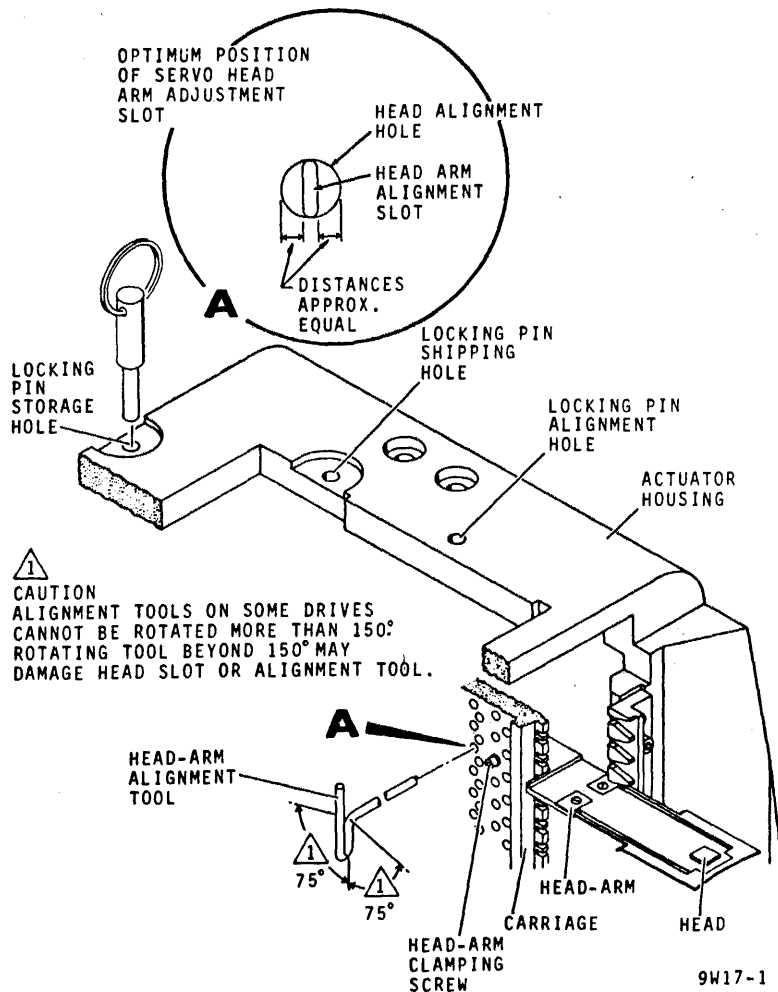

*****CAUTIONS*****

These two notes appear in the CDC Service Manual for the RM05 and are well worth memorizing before you attempt a head alignment.

If the heads perform an unscheduled retract and the START and FAULT lights are both off, immediately turn off the +20Y breaker. You have dropped +5 Volts and run the risk of burning up the voice coil. Only after you've thus disabled the DC power supply should you check to see if the power-down resulted from a failure on the AC line. The blower will still be on if the AC power is OK.

Caution #2: Should an emergency retract occur with the locking pin in the alignment track lock hole, the following may occur.

- 1.) Blown fuse
- 2.) Tripped DC circuit breaker
- 3.) Blown power amplifier transistors
- 4.) Any of the above = Unretracted heads on a stationary CE pack.

Head Alignment Continued...

- 7.) If heads 16, 17, or 18 require adjustment, move the servo preamp cover before proceeding. (At this point the drive should be stopped.)
- 8.) Loosen screws on the heads to be adjusted and torque them to 4 + 1/2 lbf-in.
- 9.) Start the drive and command a direct seek to cylinder 753.

NOTE

Force exerted during head alignment can move the heads from the alignment cylinder to an adjacent cylinder, resulting in an improper alignment. Prevent this by connecting a jumper from A07-11A (seek error) to ground. Be sure to remove the jumper before commanding another seek.

If you use this jumper, remember to put the jumper on the signal end while the power is off. Then, when the drive is powered up and on cylinder, place the other end of the jumper to ground.

- 10.) Using the FTU, select the head to be aligned. To prevent personal injury, place the locking pin in the alignment track lock hole. Remember to remove it before commanding another seek.
- 11.) Install head alignment tool so that the tool pin engages the hole in the head-arm alignment slot. Observe the oscilloscope and adjust head to obtain a balanced dibit pattern.
- 12.) Observe the null meter and adjust the head until the offset is less than + 75 mV. If head cannot be brought into alignment, you may have to re-center the servo head. Any adjustment of the servo head will require realignment of all data heads.

- 13.) Remove carriage locking pin and also the jumper from A07-11A. Spin down the drive.
- 14.) Final torque all the heads to 12 +1/2 lbf-in.
- 15.) Spin up drive and check to see that all heads adjusted are within specifications. Readjust those which are outside of the ± 150 mV limits.

When head alignment is complete, perform all servo checks.

SERVO SYSTEM CHECKS AND ADJUSTMENTS

The servo system adjustments are interactive and must be performed in sequence to be valid. The servo system flow chart shows the order in which they must be performed.

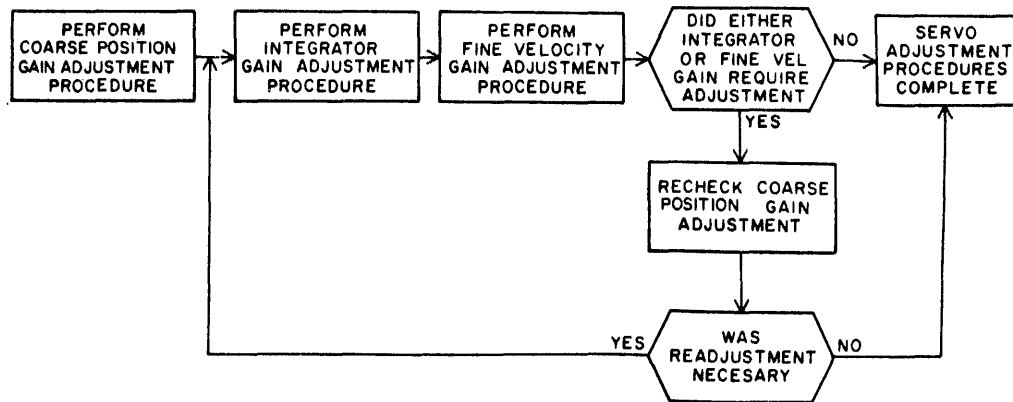

- 1.) COARSE POSITION GAIN. Prepare the drive for use with the FTU.
 - 2.) Command continuous seeks between 000₈ and 1466₈.
 - 3.) Connect oscilloscope CH1 to A07-03A (+On Cylinder).
 - 4.) External Trigger scope to A07-07A (-Forward Seek).
 - 5.) Observe display. If distance between on cylinder pulses is not between 50 to 54 mS, adjust top potentiometer on card A20 to meet this spec.
-
- 1.) INTEGRATOR GAIN ADJUSTMENT. Command continuous seeks between cylinders 000₈ and 200₈. Set up scope as indicated in drawing on the next page. Adjust the scope until the two sloped curves are displayed as in the drawing.
 - 2.) You want to examine closely the second to last discontinuity. This will require some fiddling with the scope in order to lock this portion of the wave.
 - 3.) Adjust the bottom pot on the A20 board until the wave is correct.

OSCILLOSCOPE SETTINGS

LOGIC GND TO SCOPE GND

VOLTS / DIV
 CH 1 - 0.5V/CM
 CH 2 - NOT USED

TIME / DIV
 A - 0.5MS/CM
 B - NOT USED

TRIGGERING
 A - POSITIVE EXT ON A12-17B (+T ≤ 7)
 B - NOT USED

PROBE CONNECTIONS
 CH 1 TO A20-TPD (+ DESIRED VELOCITY)
 CH 2 - NOT USED

NOTE:
 HORIZ DISPLAY
 SET TO MAG x 10

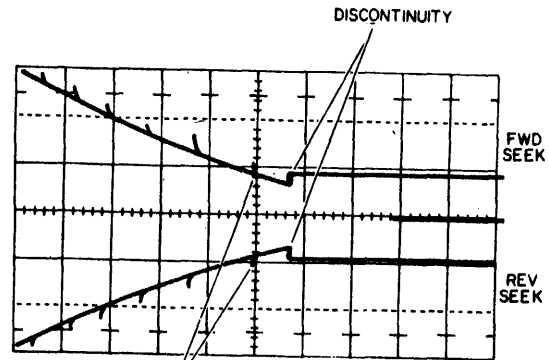

NOTE:
 IT IS NECESSARY TO INCREASE
 VERTICAL SENSITIVITY TO MAKE
 THIS MEASUREMENT.

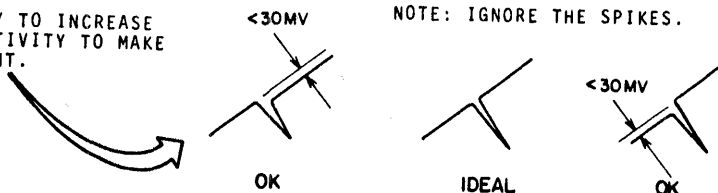

9W18

INTEGRATOR GAIN WAVEFORM

- 1.) FINE VELOCITY GAIN. Command a read in conjunction with a continuous seek between cylinders 000_g and 001_g.
- 2.) Connect and adjust scope as indicated by the drawing on the next page.
- 3.) The top wave form in the drawing is an overshoot condition which is not desirable. Adjust the middle pot on the A20 module to as nearly as possible resemble the ideal waveform. Best operation is attained with it adjusted slightly toward the under shoot waveform which can be seen in the final waveform.
- 4.) Command a sequential seek between cylinders 000_g to 1466_g in conjunction with a read.
- 5.) Note that the displayed waveform should look similar to the Final Check waveform. If any overshoot exists greater than 0.5 Volts, adjust the middle pot on card A20 until the specification is met.

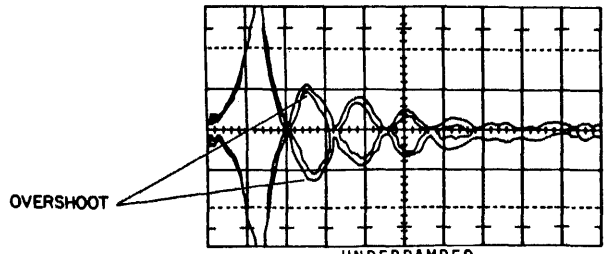

OSCILLOSCOPE SETTINGS

LOGIC GND TO SCOPE GND

VOLTS / DIV
 CH 1 - 0.5V/CM
 CH 2 - NOT USED

TIME / DIV
 A - 1MS/CM
 B - NOT USED

TRIGGERING
 A - NEGATIVE ON A07-30A^(AT OG)
 (-SEEK)
 B - NOT USED

PROBE CONNECTIONS
 CH 1 TO A19-TPC
 (+FINE POSITION ANALOG)
 CH 2 - NOT USED

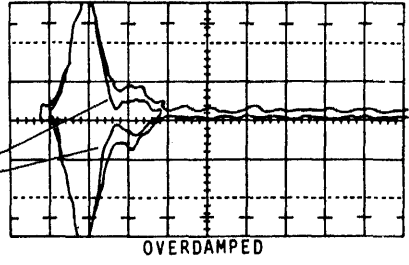
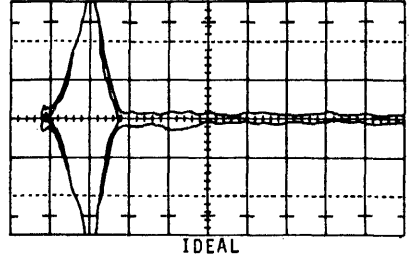

INITIAL FINE VELOCITY GAIN

OSCILLOSCOPE SETTINGS

LOGIC GND TO SCOPE GND

VOLTS / DIV
 CH 1 - 0.5V/CM
 CH 2 - NOT USED

TIME / DIV
 A - 0.1MS/CM
 B - NOT USED

TRIGGERING
 A - EXT, A07-30A (-SEEK)
 B - NOT USED

PROBE CONNECTIONS
 CH 1 TO A19-TPC (+FINE POSITION ANALOG)
 CH 2 - NOT USED

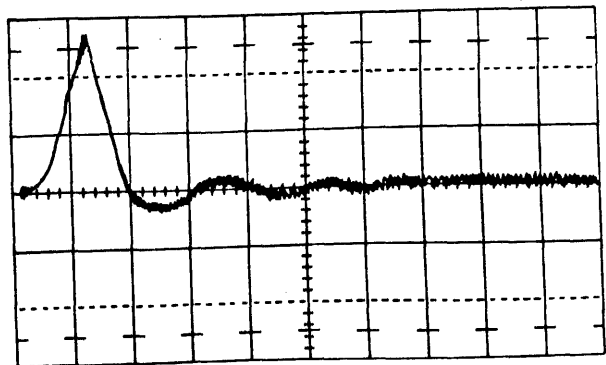

FINAL FINE VELOCITY GAIN

RM05 Write Circuits Tests

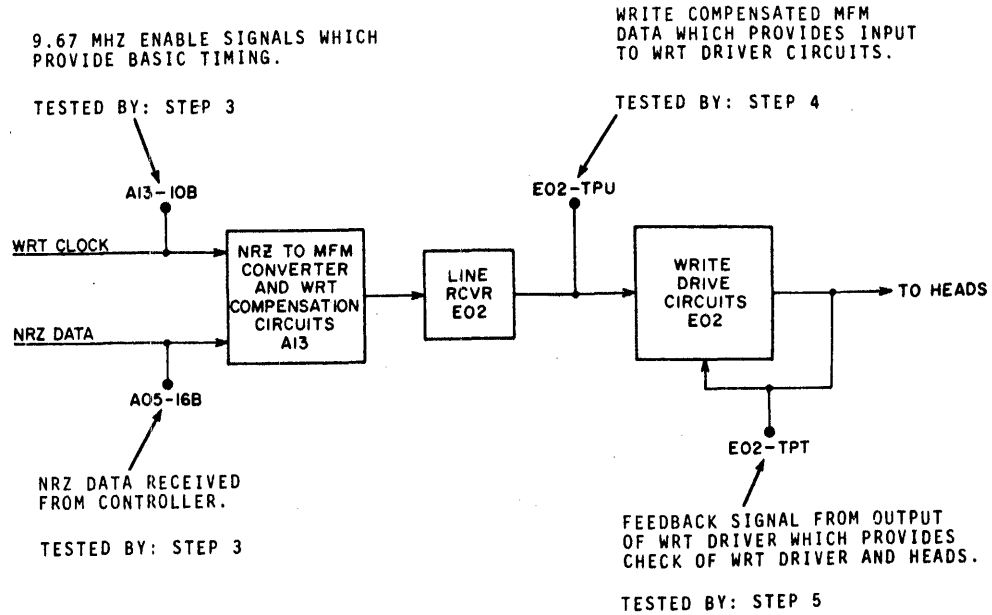

- 1.) Connect the drive to the FTU and command a 1010 bit pattern write to the disk.
- 2.) Check each test point from the block diagram above against the waveforms on the next few pages. Scope set-ups are included with each drawing.

OSCILLOSCOPE SETTINGS

LOGIC GND TO SCOPE GND

VOLTS / DIV

CH 1 - 0.2V/CM
CH 2 - 0.2V/CM

TIME / DIV

A - 2MS/CM
B - 0.05 S/CM

TRIGGERING

A - +EXT, A06-TPC (INDEX)
B - -INT

PROBE CONNECTIONS (10X PROBES)

CH 1 TO A13-TPE (NRZ DATA)
CH 2 TO A13-TPB (WRT STROBE)

NOTE: SET TO DISPLAY MODE TO ALT AND TRIGGER MODE TO CH 1 ONLY.
ALSO SET HORIZONTAL DISPLAY TO B (DELAYED SWEEP)



OSCILLOSCOPE SETTINGS

LOGIC GND TO SCOPE GND

VOLTS / DIV
CH 1 - 0.2V/CM
CH 2 - 0.2V/CM

TIME / DIV
A - 2MS/CM
B - 0.05μS/CM

TRIGGERING
A - +EXT, A06-TPC (+INDEX)
B - -INT

PROBE CONNECTIONS (10X PROBES)
CH 1 TO A13-TPE (NRZ DATA)
CH 2 TO E02-TPU

NOTE: SET DISPLAY MODE TO ALT AND TRIGGER MODE TO CH 1 ONLY.
ALSO SET HORIZONTAL DISPLAY TO B (DELAYED SWEEP)

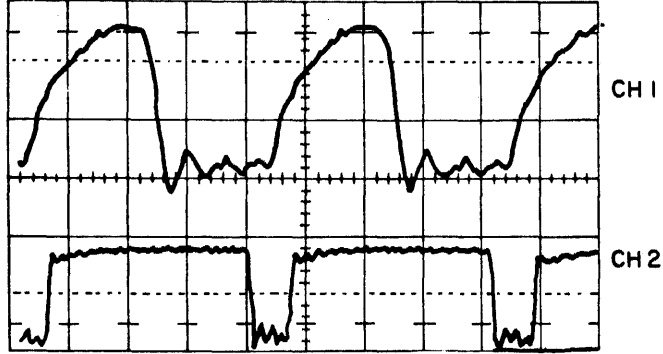

RM05 Write Driver Input

OSCILLOSCOPE SETTINGS

LOGIC GND TO SCOPE GND

VOLTS / DIV
CH 1 - 0.2V/CM
CH 2 - 0.2V/CM

TIME / DIV
A - 2MS/CM
B - 0.05μS/CM

TRIGGERING
A - +EXT, A06-TPC (+INDEX)
B - -INT

PROBE CONNECTIONS (10X PROBES)
CH 1 TO A13-TPE (NRZ DATA)
CH 2 TO E02-TPT

NOTE: SET DISPLAY MODE TO ALT AND TRIGGER MODE TO CH 1 ONLY.
ALSO SET HORIZONTAL DISPLAY TO B (DELAYED SWEEP)

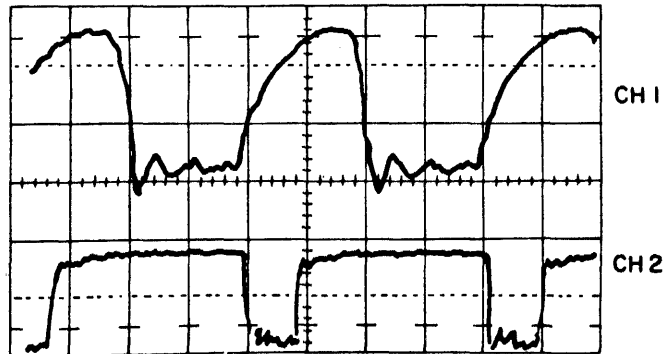

RM05 Write Driver Output

RM05 Read Circuits Tests

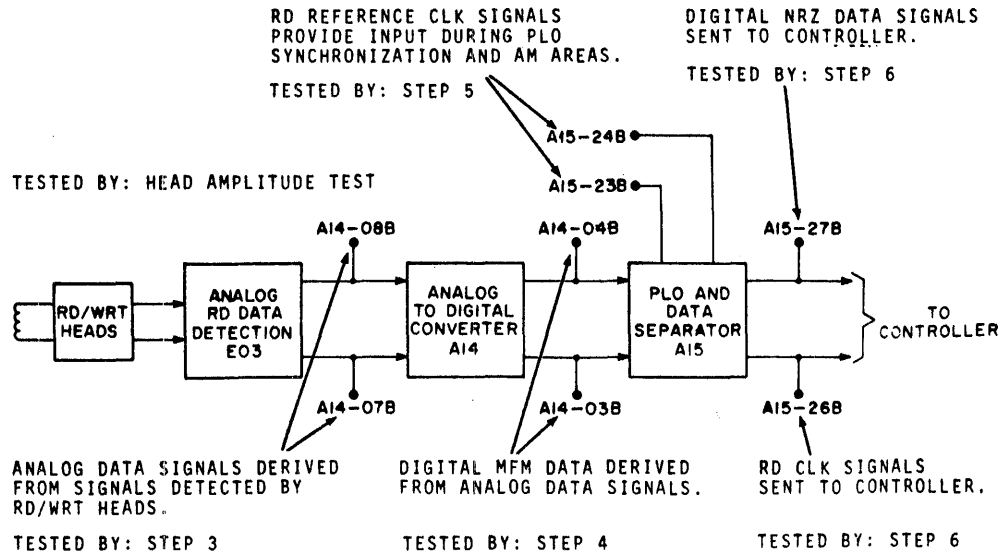

- 1.) Connect drive to FTU. Command a write data, pattern 1010.
- 2.) Command drive to read pattern 1010. Verify that all waveforms are consistent with those shown on next few pages. Scope setups are included with the waveforms.

RM05 Analog Read Data Waveform

LOGIC GND TO SCOPE GND

VOLTS / DIV

CH 1 - 0.1V/CM
CH 2 - 0.1V/CM

TIME / DIV

A - 2MS/CM
B - 0.05 S/CM

TRIGGERING

A - +EXT, A06-TPC (+INDEX)
B - -INT

PROBE CONNECTIONS (10X PROBES)

CH 1 TO A14-08B (-ANALOG DATA)
CH 2 TO A14-07B (+ANALOG DATA)

NOTE: SET DISPLAY MODE TO ADD AND INVERT ONE CHANNEL.
ALSO SET HORIZONTAL DISPLAY TO B (DELAYED SWEEP)

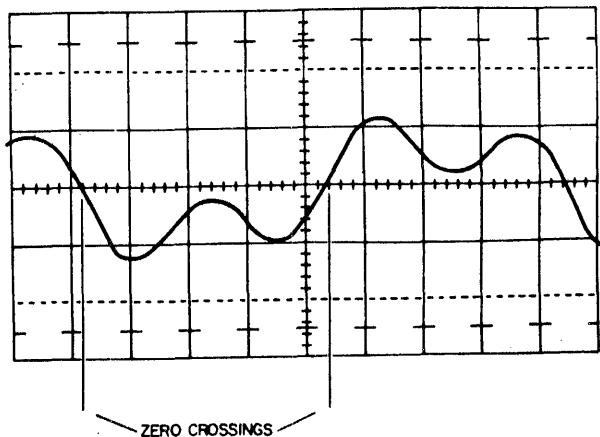

OSCILLOSCOPE SETTINGS

LOGIC GND TO SCOPE GND

VOLTS / DIV
CH 1 - 0.1V/CM
CH 2 - 0.1V/CM

TIME / DIV
A - 2MS/CM
B - 0.05S/CM

TRIGGERING
A - +EXT, A06-TPC (+INDEX)
B - -INT

PROBE CONNECTIONS (10X PROBES)
CH 1 TO A14-03B (+RD DATA)
CH 2 TO A14-04B (-RD DATA)

NOTE: SET DISPLAY MODE TO ADD AND INVERT ON CHANNEL.
ALSO SET HORIZONTAL DISPLAY TO B (DELAYED SWEEP)

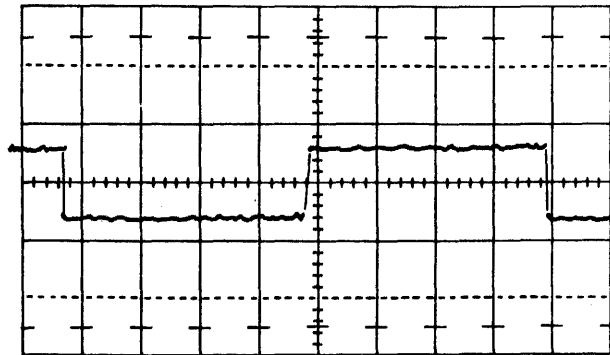

RM05 Data Latch Output Waveform

READ CLOCK CHECKS...

Use same setup as above except move CH1 probe to A15-24B.
Move CH2 probe to A15-23B. Observe that the displayed
signal has a frequency of 4.84 Mhz.

NOTE: SET DISPLAY MODE TO ALT AND TRIGGER MODE TO CH 1 ONLY.
ALSO SET HORIZONTAL DISPLAY TO B (DELAYED SWEEP)

OSCILLOSCOPE SETTINGS

LOGIC GND TO SCOPE GND

VOLTS / DIV
CH 1 - 0.2V/CM
CH 2 - 0.2V/CM

TIME / DIV
A - 2MS/CM
B - 0.05μS/CM

TRIGGERING
A - -EXT, A15-12B (-READ GATE)
B - -INT

PROBE CONNECTIONS (10X PROBES)
CH 1 TO A15-27B
CH 2 TO A15-26B

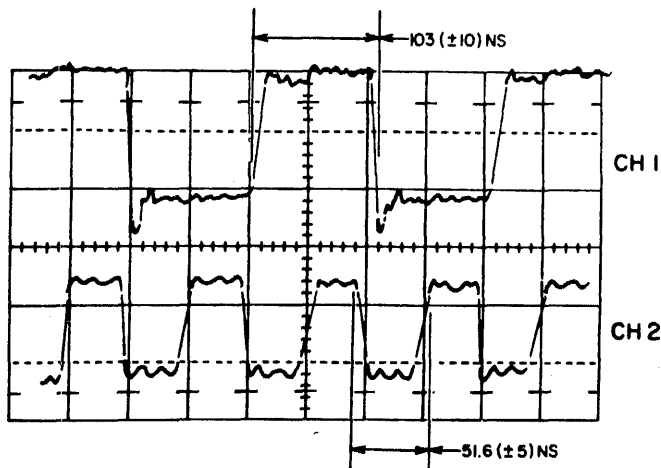

RM05 Read Data to Read Clock Timing

RM05 Head Amplitude Check

This procedure will verify that the amplitude of the signal off of the R/W head is sufficient to allow reliable processing of data.

Amplitude is inversely proportional to the frequency of recording data. Therefore, the highest amplitude will be observed when reading all ones. The lowest amplitude will be observed when reading alternating ones and zeros.

- 1.) Connect drive to FTU. Command drive to seek to cylinder 1466.8 Command drive to write all ones on each head of that cylinder.
- 2.) Connect External trigger (negative) to A06-TPC (Index). Connect CH1 to E03-TPB. Connect CH2 to E03-TPC and set display mode to ADD and invert one channel. Set Volt/div and Time/div as required.
- 3.) Command drive to read all ones and step through each head in turn. The minimum level should be 130 mV peak to peak.
- 4.) Command drive to seek to cylinder 001, and write a 1010 pattern on all heads.
- 5.) Command drive to read. Step through each head in turn and verify that the amplitude of each is a maximum of 1100 mV.

Index Timing Check.

- 1.) Connect CH1 to A06-TPC (+Index). Trigger internal positive.
- 2.) Observe that the Index is a logic one for 2.5 (+0.3) uSec.
- 3.) Observe that the time between pulses is approximately 16.7 ms.

Speed Sensor Output Check

- 1.) Connect CH1 to A17-17A. Trigger internal positive.
- 2.) Observe amplitude on scope. Signal should have positive and negative amplitudes of at least 600mV. If not, the speed sensor gap may be misadjusted.

SERVO AMPLITUDE CHECK

NOTE: SET DISPLAY MODE TO ADD AND INVERT ONE CHANNEL

OSCILLOSCOPE SETTINGS

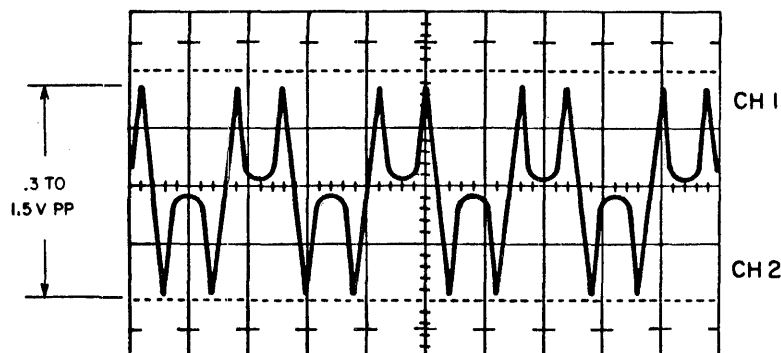

LOGIC GND TO SCOPE GND

VOLTS / DIV
CH 1 - 0.5V/CM
CH 2 - 0.5V/CM

TIME / DIV
A - 1μS CM
B - NOT USED

TRIGGERING
A - INTERNAL NEGATIVE
B - NOT USED

PROBE CONNECTIONS
CH 1 TO A18-25B (-DIBITS)
CH 2 TO A18-23B (+DIBITS)

OSCILLOSCOPE SETTINGS

LOGIC GND TO SCOPE GND

VOLTS / DIV

CH 1 - 0.1V/CM (READ SCALE AS 100MV)
CH 2 - NOT USED

TIME / DIV

A - 2MS/CM
B - NOT USED

TRIGGERING (POSITIVE/EXTERNAL)

A - INDEX
B - NOT USED

PROBE CONNECTIONS

CH 1 TO A19-TPC (FINE POS ANALOG)
CH 2 - NOT USED

NOTES:

1. MORE THAN NORMAL RUNOUT RESULTS IN THE WAVEFORM HAVING A 60 Hz SINUSOIDAL COMPONENT AS SHOWN ON WAVEFORM A. AS AMOUNT OF RUNOUT INCREASES, THE PEAK TO PEAK AMPLITUDE OF THE 60 Hz COMPONENT INCREASES.
2. NORMAL RUNOUT IS SHOWN ON WAVEFORM B. IN THIS CASE, THE AMPLITUDE OF THE 60Hz SINUSOIDAL COMPONENT IS LESS THAN 400MV PEAK TO PEAK.

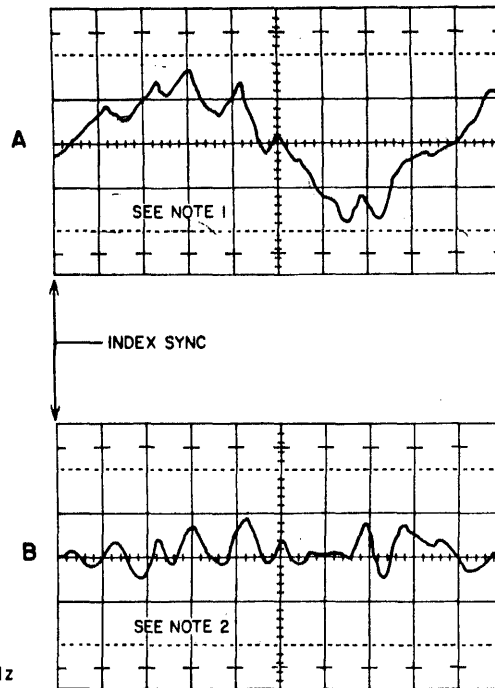

RM05 TRACK FOLLOWING CHECK

Inability to stay on track may be due to excessive pack or spindle assembly runout. It may also be due to drifting or 'hunting' servo circuits or bad AGC action. Inability of the heads to follow the track may cause read errors or occasionally cause the drive to lose On Cylinder.

- 1.) Connect the drive to the FTU. Connect the scope as indicated above. (Index is A06-TPC).
- 2.) Command a direct seek to cylinder 620. Observe the display using the above for reference. If the 60 Hz component is greater than 400 mV, then excessive runout exists.
- 3.) If runout exists, note the phase relationship of the 60 Hz component.
- 4.) Stop the drive. Note the position of the pack on the spindle and remove the pack. Replace the pack 90 degrees (1/4 turn) from where it was. Start the drive and command a direct seek to cylinder 620.
- 5.) Compare phase relationships with the signal now displayed and the one obtained earlier.
 - a. If the phase relationship of both waveforms are the same, then runout is due to the disk pack or a servo fault.
 - b. If phase relationship has changed, then the runout is due to the spindle or again a servo fault.

RM05 SERVO CHECKS

OSCILLOSCOPE SETTINGS

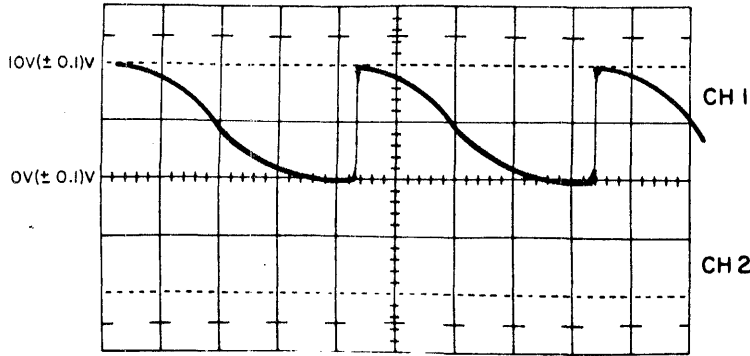

LOGIC GND TO SCOPE GND

VOLTS / DIV
 CH 1 - 5V/CM
 CH 2 - NOT USED

TIME / DIV
 A - 5MS/CM
 B - NOT USED

TRIGGERING
 A - NEG EXT, A07-07A (-FWD SEEK)
 B - NOT USED

PROBE CONNECTIONS
 CH 1 TO A20-TPB
 CH 2 - NOT USED

D to A Output Check

The D to A converter produces some maximum value and steps down as each track is crossed. It should produce 0 V when on cylinder. The above waveform was taken doing continuous seeks between cylinders 000_g and 200_g.

Cylinder Pulse Blanking Delay Check

Command continuous seeks between cylinders 000_g and 003_g. Connect CH1 to A07-30B (+ Cylinder Pulse Blanking). Trigger positive internal. Observe that the Cylinder Pulse Blanking delay is a one for 950 (+50) uSec.

Cylinder Pulse One Shot Check

Make same preparations as Cylinder pulse blanking check except connect CH1 to A07-22A (+Cylinder Pulses). Observe that the cylinder pulse is a one for 10 (+2.5) uSec.

OSCILLOSCOPE SETTINGS

Cylinder Pulse Switching Level Check

LOGIC GND TO SCOPE GND

NOTE:
 TIME/DIV AND PROBE CONNECTIONS ARE COMMON TO ALL THE FOLLOWING WAVEFORMS.

TIME / DIV

A - .2 MS/CM
 B - NOT USED

PROBE CONNECTIONS

A - CH 1 TO A18-09 B (+TRACK SERVO SIGNAL)
 CH 2 - NOT USED

+0.4(±.1)V

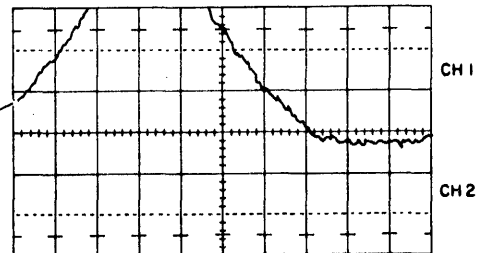

VOLTS / DIV

CH 1 - .5V/CM
 CH 2 - NOT USED

TRIGGERING

A - NEG EXT, A18-08B (+CYL DET B)
 B - NOT USED

VOLTS / DIV

CH 1 - .1V/CM
 CH 2 - NOT USED

TRIGGERING

A - POS EXT, A18-08B (+CYL DET B)
 B - NOT USED

0(±.1)V

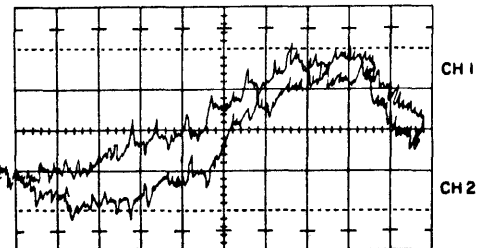

Cylinder Pulse Switching Level Check

The waveform on the preceding page was taken under the following conditions:

Drive connected to FTU. Command sequential seeks between cylinders 000_g and 1466_g (forward). The other two waveforms are below this text.

OSCILLOSCOPE SETTINGS

VOLTS / DIV
CH 1 - .5V/CM
CH 2 - NOT USED

TRIGGERING
A- NEG EXT. A18-07B (+CYL DET A)
B- NOT USED

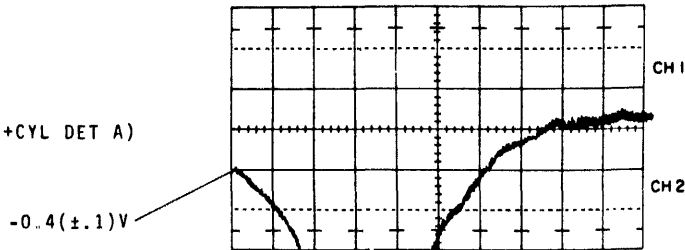

VOLTS / DIV
CH 1 - .1V/CM
CH 2 - NOT USED

TRIGGERING
A- POS EXT. A18-07B (+CYL DET A)
B- NOT USED

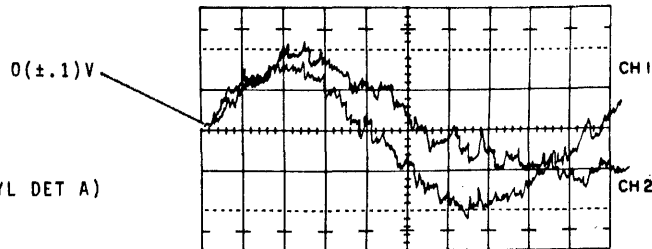

Fine Enable Switching Level

Connect the drive to FTU and command continuous seeks between cylinders 000_g and 001_g. Compare display with drawing below.

NOTE: SET DISPLAY MODE TO CHOP.

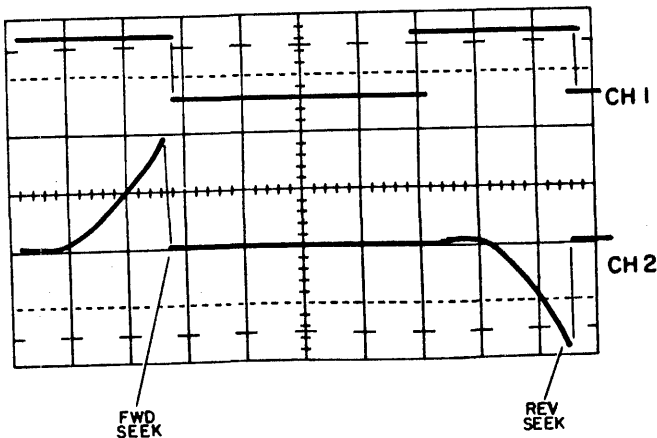

OSCILLOSCOPE SETTINGS

LOGIC GND TO SCOPE GND

VOLTS / DIV
CH 1 - 5V/CM
CH 2 - 0.5V/CM

TIME / DIV
A - 0.5MS/CM
B - NOT USED

TRIGGERING
A - EXT NEG, A20-12A (-FWD SEEK)
B - NOT USED

PROBE CONNECTIONS
CH 1 TO A20-10A (-FINE ENABLE)
CH 2 TO A20-TPG (+INTEGRATED VEL)

NOTES

FIELD CHANGE ORDER

DATE APPROVED APR 04 1980 PAGE 1 OF 6

EQUIPMENT IDENTIFICATION NO. TB3A2A	PRODUCT NAME FTU FIELD TEST UNIT	FCO PACKAGE P/N 89053768		CLASS I <input checked="" type="checkbox"/> II <input type="checkbox"/>
	FIELD UNITS AFFECTED TB3A2A SERIES CODE 06 THROUGH 19 SEE ITEM 4	AFFECTED BY FCO <input type="checkbox"/>	YES NO <input checked="" type="checkbox"/> <input type="checkbox"/>	
MFG. INCORPORATION SERIES CODE <u>21</u>	PUBLICATIONS	<input checked="" type="checkbox"/> <input type="checkbox"/>		
	SOFTWARE CHECKOUT	<input type="checkbox"/> <input checked="" type="checkbox"/>		
	SAFETY	<input type="checkbox"/> <input checked="" type="checkbox"/>		

THIS FCO MUST CONTAIN THE FOLLOWING SUBJECTS IN ORDER:
1. REASON FOR CHANGE. 2. MANUALS AFFECTED. 3. DESCRIPTION OF CHANGE. 4. REFERENCE.
5. INSTALLATION PROCEDURE. 6. PARTS AND SPECIAL TOOLS REQUIRED. 7. PARTS AND TOOLS AVAILABILITY.
8. REMOVED PARTS DISPOSITION. 9. ATTACHED DOCUMENTS.

- REASON FOR CHANGE: ALLOW TB3A2A TO SELECT ALL HEADS ON THE 9766.
- MANUALS AFFECTED: TB3A2A HARDWARE MAINTENANCE MANUAL {83322710}
- DESCRIPTION OF CHANGE: REWORK W/W ASSEMBLY AND ADD A DIODE TO COMPONENT SIDE OF LOGIC BOARD.
- REFERENCES: THIS CHANGE WILL BE INSTALLED BY MANUFACTURING IN UNITS WITH SERIAL NUMBERS 3990, 3998 AND ABOVE.
- INSTALLATION PROCEDURE: **NOTE:** A 30 AWG WIRE WRAP TOOL AND 30 AWG WIRE WRAP WIRE ARE REQUIRED FOR THIS CHANGE.
 - A. OPEN FTU TO GAIN ACCESS TO W/W BACKPANEL.
 - B. MAKE FOLLOWING CHANGES TO WIRE WRAP ASSEMBLY:

DELETE:

<u>ORIGIN</u>	<u>DESTINATION</u>	<u>LEVEL</u>
D26-012	JC31-035	2
E30-006	E13-005	2
E30-006	F19-011	1

REF. ECO PE54280

ORIGINATOR 8-3-80 J.P. STUDENSKI	ENGINEER <i>[Signature]</i> D. GABRIELSON	MFG. <i>[Signature]</i> 4-1-80	PC <i>[Signature]</i> 4-4-80	QA <i>[Signature]</i> 4-7-80	FCO ADMINISTRATOR <i>[Signature]</i>
--	--	-----------------------------------	---------------------------------	---------------------------------	--------------------------------------

PE 54280

FIELD CHANGE ORDER

APR 04 1980

DIV.	F.C.O. NO.	REV.
PE	54280	

PAGE 2

INSTALLATION PROCEDURE CONT'D

ADD:

<u>ORIGIN</u>	<u>DESTINATION</u>	<u>LEVEL</u>
E30-006	JC31-018	1
F04-006	JC31-035	2
F04-012	D26-012	2
E30-006	E13-005	2

- C. ON THE COMPONENT SIDE OF THE LOGIC BOARD, SOLDER THE SILICON DIODE {24553500} BETWEEN PINS 6 & 12 OF CHIP LOCATION F04. INSURE THE NEGATIVE OR CATHODE END OF THE DIODE IS ATTACHED TO PIN 6. IF IN DOUBT AS TO WHICH END IS NEGATIVE OR THE CATHODE, CHECK WITH VOM TO VERIFY CORRECT POLARITY.

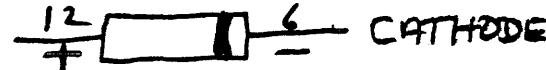

- D. CLOSE FTU AND CONNECT TO A 9766. OPERATE DRIVE AND FTU CHECKING THE FTU'S ABILITY TO SELECT ALL HEADS ON THE 9766.

- E. LOG FCO ON UNIT FCO LOG.

- F. UPDATE MAINTENANCE MANUAL DIAGRAMS WITH PAGES 4, 5 AND 6.
UPDATE MAINTENANCE MANUAL WIRE LIST.

6. PARTS & SPECIAL TOOLS: FCO KIT NUMBER {89053768} SEE ASSEMBLY PARTS LIST

7. AVAILABILITY: KITS DUE BEGINNING APRIL 11, 1980

8. REMOVED PARTS: N/A

9. ATTACHED DOCUMENTS: N/A

REMOVE 3 SCREWS FROM COMPONENT SIDE OF FTU LOGIC. LOWER PC BOARD DOWN TO POWER

SURVEY BY HINGED BOTTOM. SEE NEXT PAGE FOR WIREWRAP SIDE DIAGRAM.

FTU

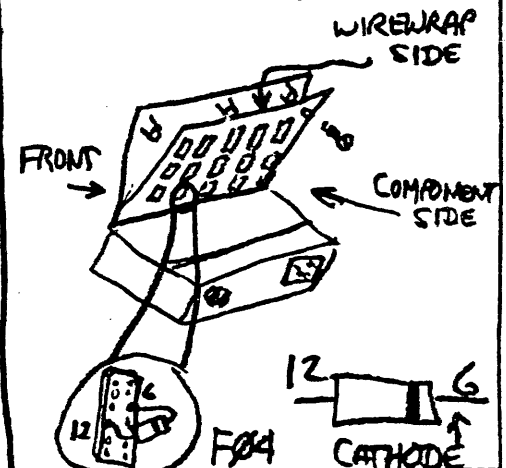

APR 04 1980

ASSEMBLY PARTS LIST

DIV.	ASSEMBLY NUMBER	REV.	DESCRIPTION	
052	89053768		FCO KIT PE54280	
FIND NO.	PART NUMBER	QUANTITY	U/M	PART DESCRIPTION
001	24553500	001	ea	SILICONE DIODE

WIREWRAP CONFIGURATION

PANEL ↑

PC BOARD - PIN SIDE

Page 36

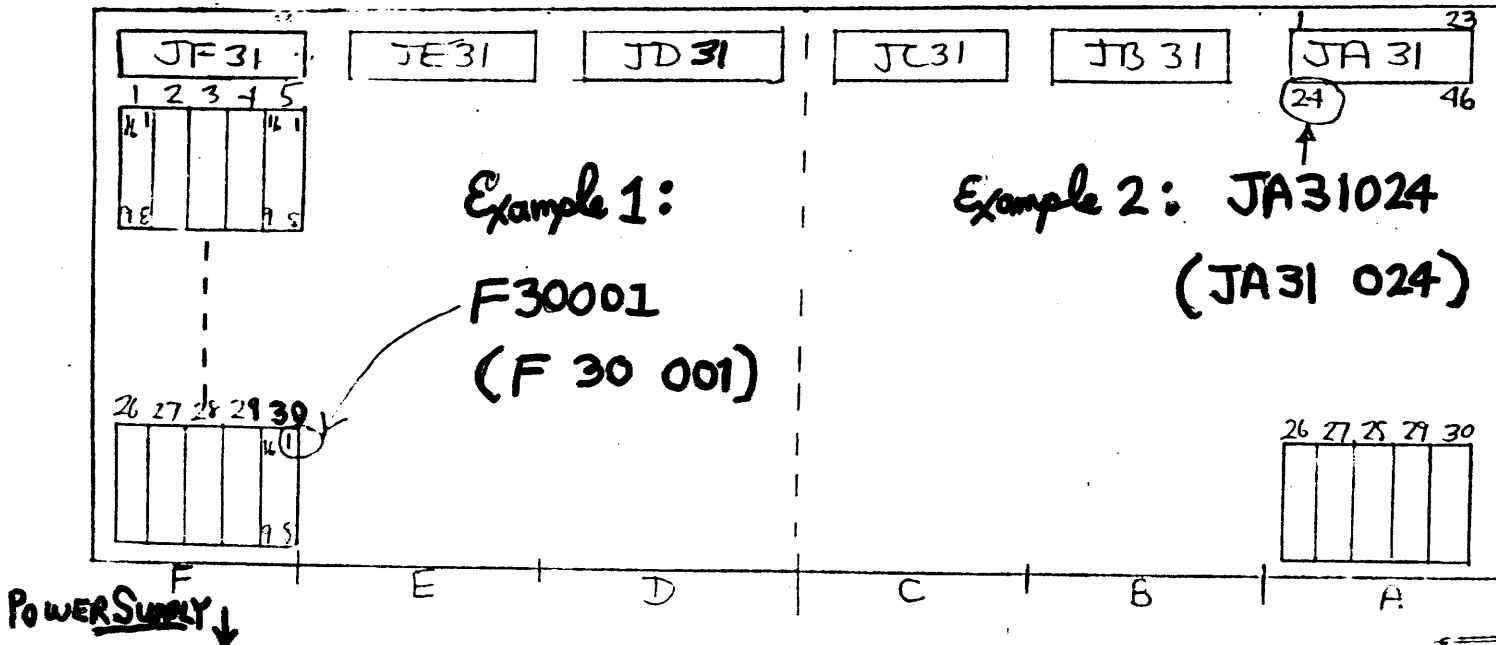

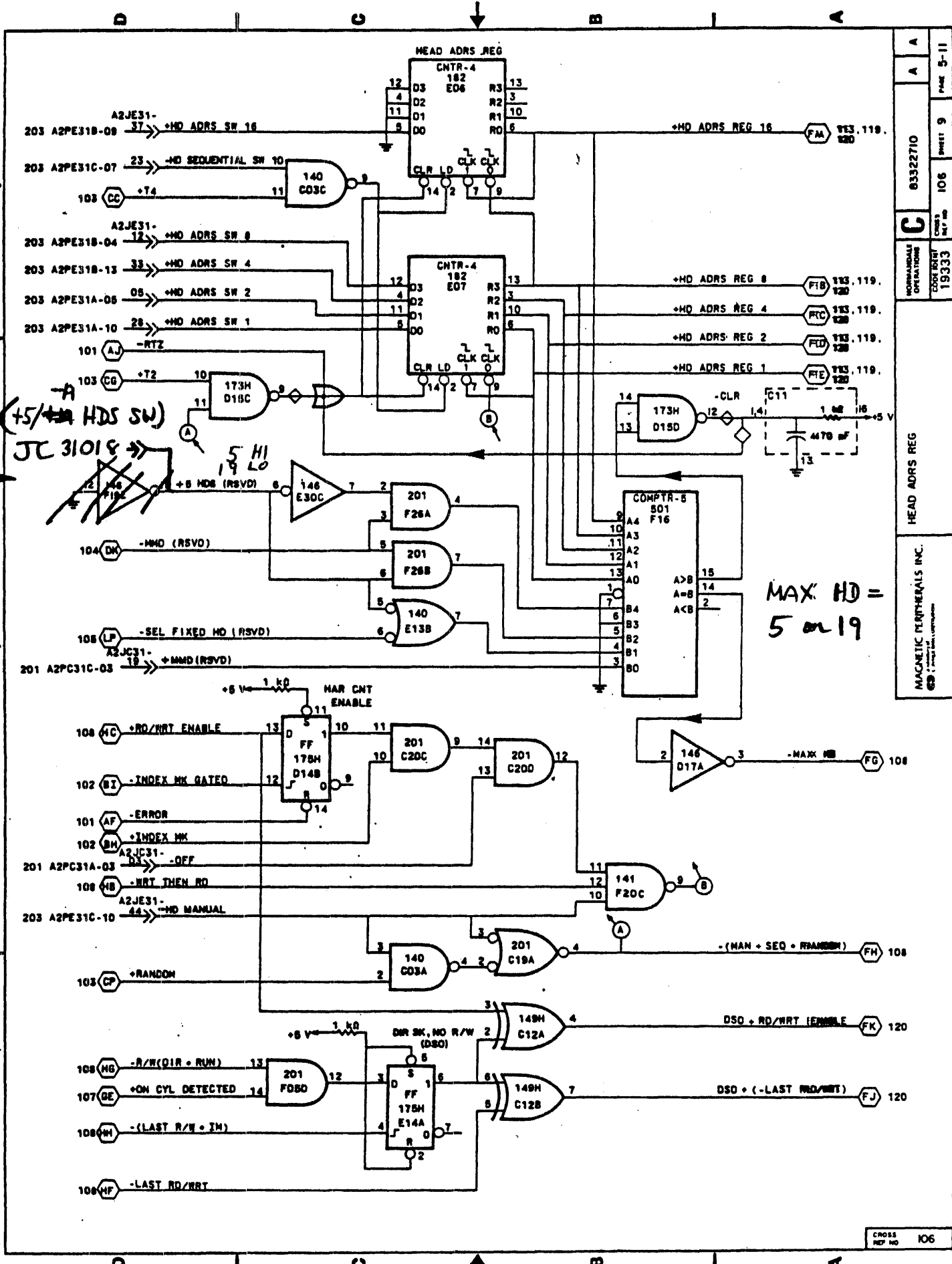

93322710	9	106	5-11
19333	106	9	5-11
HEAD ADRS REG			
MAGNETIC PERIPHERALS INC.			

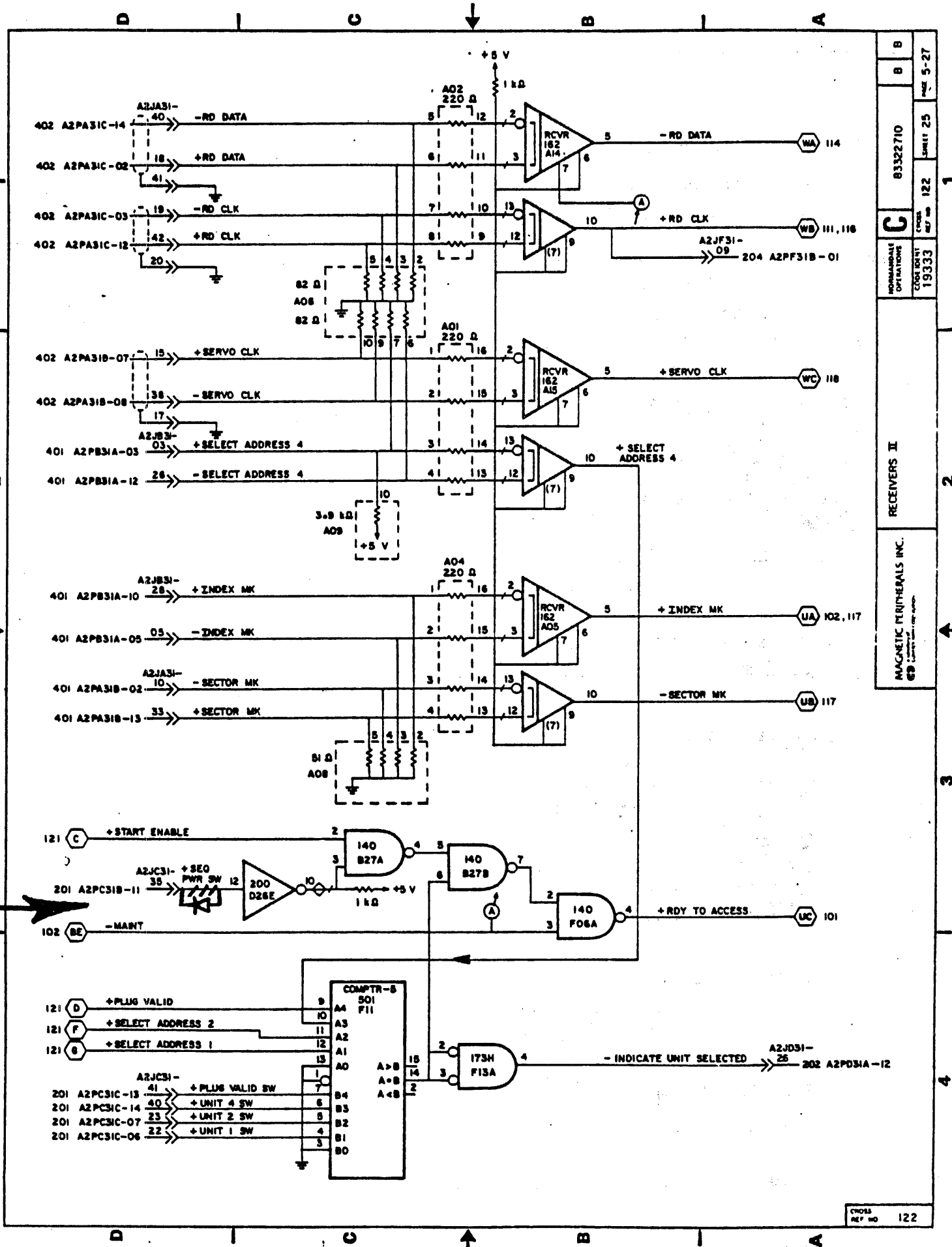

D	C	B	A	83322710	8	8	
				19333	122	122	25
RECEIVERS II				MAGNETIC PERIPHERALS INC.			
CROSS REF NO 122				CROSS REF NO 122			

digital	FIELD SERVICE TECHNICAL MANUAL				Option or Designator
	12 Bit <input type="checkbox"/>	16 Bit <input checked="" type="checkbox"/>	18 Bit <input type="checkbox"/>	36 Bit <input type="checkbox"/>	RM05

Title RM05 HEAD CRASHES				Tech Tip Number RM05-TT-	
Author Bill Peters		F.S. Office Maynard	Date 2-28-81	Revision A	
Processor Applicability		Mgr./Sup.	Date	Cross Reference	
All	16 VAX	Approval:	Date		

Due to the very low flying height of the heads and the critical characteristics of the RM05 packs, it is recommended that if a head crash is experienced, you should replace all the heads in the drive. There is no way you can determine with the unaided eye whether or not the remaining heads are good or not. This requires a microscope and a thorough knowledge of head construction.

In the event of a crash, the following steps should be taken:

- 1.) Because the RM05 uses a perforated shroud assembly, you must disassemble the shroud and clean the deck area very thoroughly. Some repeat crashes have been attributed to contamination left in the drive from the original crash.
- 2.) Take no chances. Replace every head when reassembling the drive. Visually inspect each head for signs of improper assembly or contamination before installing.
- 3.) Inspect the positioner and magnet for metal particles. **BE THOROUGH IN EVERY RESPECT.**
- 4.) When drive is reassembled, allow the drive to purge for a minimum of 30 minutes. Visually inspect the shroud area before installing a new scratch pack.
- 5.) When the pack has spun up for a few minutes and things look stable, you can then procede with the head alignment procedures.

Here are some important points to remember:

CDC does not recommend head or media cleaning on the 9766. The tolerances involved are much more critical than the RP06 or similar drives.

DEC CONFIDENTIAL

This document is proprietary to Digital Equipment Corporation and is intended for use by its Field Service Organization only. For information on writing or approving a Tech Tip, see Administration Tech Tip Number 2.

Page 1	Page Revision	Publication Date
---------------	---------------	------------------

PRINTED IN U.S.A.

DEC 1189C 12 R277-(79Y)

digital	FIELD SERVICE TECHNICAL MANUAL				Option or Designator
	12 Bit <input type="checkbox"/>	16 Bit <input type="checkbox"/>	18 Bit <input type="checkbox"/>	36 Bit <input type="checkbox"/>	RM05

Title RM05 HEAD CRASHES (Continued)			Tech Tip Number RM05-TT-		
Author Bill Peters		F.S. Office Maynard		Date 2-28-81	Revision A
Processor Applicability			Mgr./Sup.		Date
All 11 VAX			Approval:		Date
					Cross Reference

Due to the 'Burnished media' technology used on these packs, the normal pack cleaning procedures tend to leave a residue on the platter surfaces. The media requires a special power wash cycle to insure that all the residue is removed. Again, only a keen eye trained to recognize a media defect can spot a problem by inspecting a pack. CDC recommends a program of media inspection at certain intervals but will not recommend any cleaning. Therefore a clean environment and proper storage of media to prevent pack contamination is strongly suggested.

If you have not done so already, purge all RM05 drives of any absolute filter assemblies with a date code of June 1, 1980 to October 31, 1980. These assemblies have been found to be a source of contamination. Epoxy used in the construction of the filter is in some cases chipping off and entering the air flow. The date code is found stamped on a yellow sticker attached to the filter. The part number for the absolute filter is 29-23591.

The maintainability group for the RM05 needs to have more complete reporting of RM05 head crashes. It has been found that some RM05 calls, especially if they are repeat crashes, have been reported on LARS against systems. This makes accurate performance statistics difficult at best. The last page of this Tech-Tip is a reporting format which should be used in every instance of a RM05 head crash until further notice. Send the completed form to: Bill Peters, Corporate Field Support Group, PK3-2 /K11. We will appreciate your assistance in this very much.

Until the head crash problem has been resolved, we recommend that all branches have their RM05 CE and scratch packs inspected at least once a month by an outside company. This is necessary to eliminate the possibility that our test packs may be a source of contamination.

DEC CONFIDENTIAL

This document is proprietary to Digital Equipment Corporation and is intended for use by its Field Service Organization only. For information on writing or approving a Tech Tip, see Administration Tech Tip Number 2.

Page 2	Page Revision	Publication Date
---------------	---------------	------------------

PRINTED IN U.S.A.

digital	FIELD SERVICE TECHNICAL MANUAL				Option or Designator
	12 Bit <input type="checkbox"/>	16 Bit <input checked="" type="checkbox"/>	18 Bit <input type="checkbox"/>	36 Bit <input type="checkbox"/>	RM05

Title RM05 HEAD CRASHES (Continued)				Tech Tip Number RM05-TT-	
Author Bill Peters		F.S. Office Maynard	Date 2-28-81	Revision A	
Processor Applicability		Mgr./Sup.	Date	Cross Reference	
All	11 VAX	Approval:	Date		

PLEASE USE THIS FORM TO DOCUMENT RM05 HEAD CRASHES FOR
 MAINTAINABILITY ENGINEERING IN COLORADO.

Branch Office _____ Cost Center _____

Customer Name _____ LARS Log # _____

RM05 Serial # _____ Pack Serial # _____

Date of failure _____ Date of installation _____

Hour Meter reading _____ Suspected cause _____

Site Environment _____

Name of Engineer _____ Tele. _____

Additional comments: _____

SEND TO: **Bill Peters**
Corporate Field Support Group
129 Parker Street PK3-2 /K11
Maynard, Mass.

CONFIDENTIAL
 This document is proprietary to Digital Equipment Corporation and is intended for use by its Field Service Corporation only.
 Information on writing or approving a Tech Tip, see Administration Tech Tip Number 2.

Page 3	Page Revision	Publication Date
---------------	---------------	------------------

PRINTED IN U.S.A.

digital	FIELD SERVICE TECHNICAL MANUAL				Option or Designator RM05
	12 Bit <input type="checkbox"/>	16 Bit <input checked="" type="checkbox"/>	18 Bit <input checked="" type="checkbox"/>	36 Bit <input checked="" type="checkbox"/>	

Title RM05 Power and Grounding Requirements				Tech Tip Number	
Author Bill Peters		F.S. Office Maynard		Date 1-6-81	
Processor Applicability		Mgr./Sup.		Date	
All		Approval:		Date	
				Revision	
				Cross Reference	

Due to the non-standard wiring scheme used on the RM05 disk drive, care must be taken to assure proper ground integrity. The drive connects to a NEMA 6R which is rated at 240V single phase and is normally used to connect an 861-B. RM05's require 208V phase to phase connection plus ground. On several sites, A C Neutral has been found to be connected where ground should be on the NEMA 6R. This causes system ground to be connected to A C Neutral through the chassis of the drive. Correct wiring is shown below.

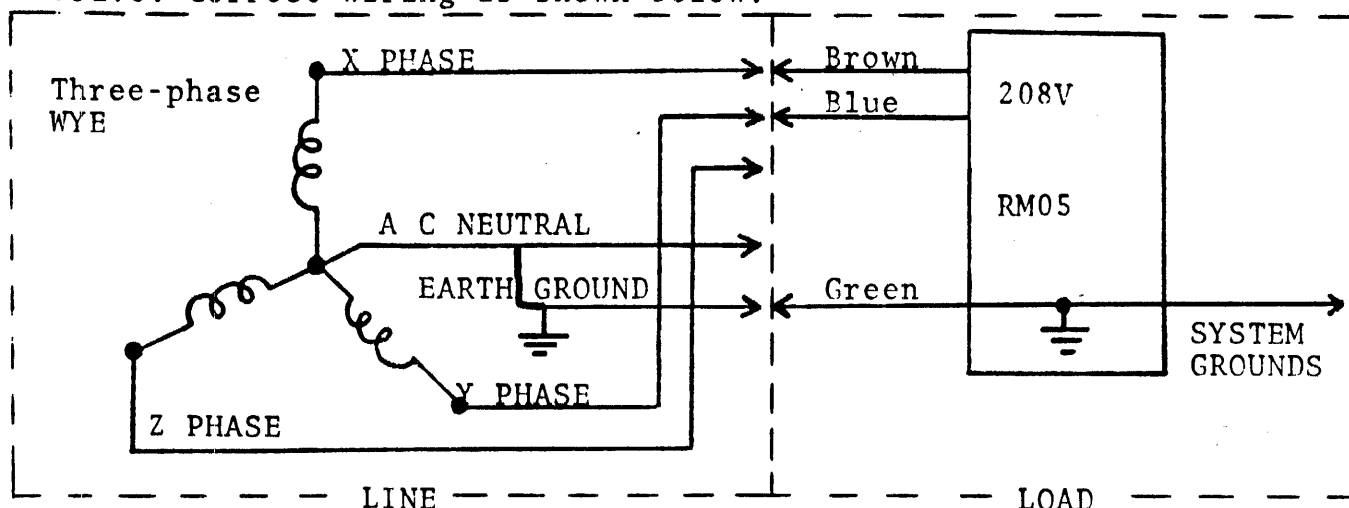

Besides the fact that connecting system ground to A C Neutral is a violation of ground safety and integrity, it also can cause some flakey problems. A C Neutral tends to be inherently noisy especially if a three-phase power imbalance exists. The drive may couple this noise into its circuits. In one case, the extra 200 mV or so of noise that coupled itself into the drives Fine Position Analog signal, caused a condition strikingly similar to excessive pack run-out.

In sites where several RM05's are installed, phase balancing becomes more critical. You don't want six RM05's connected solely to phases X and Y. If in doubt about your site, contact your local environmentalist to check it out.

DEC CONFIDENTIAL
 This document is proprietary to Digital Equipment Corporation and is intended for use by its Field Service Organization only.
 For information on writing or approving a Tech Tip, see Administration Tech Tip Number 2.

Page	Page Revision	Publication Date
------	---------------	------------------

PRINTED IN U.S.A.

digital	FIELD SERVICE TECHNICAL MANUAL				Option or Designator
	12 Bit <input type="checkbox"/>	16 Bit <input checked="" type="checkbox"/>	18 Bit <input type="checkbox"/>	36 Bit <input type="checkbox"/>	RM02/03

Title Part Number Confusion				Tech Tip Number	
Author Alan King		F.S. Office IN		Date 1-29-81	
Processor Applicability		Mgr./Sup.		Date	
All		Approval:		Date	
				Revision	
				Cross Reference	

A discrepancy exists between the RM02/03 cookbook and the CDC vendor manuals regarding the NRZ to MFM converter (LXV) module. For a RM03, order DEC # 29-22891 vendor # 54278505. This is the ELXV module.

For a RM02, order DEC # 29-23115 vendor # 54278509. This is a GLXV module.

The two are not completely cross compatible.

ALL INFORMATION CONTAINED HEREIN IS UNCLASSIFIED

EXCEPT WHERE SHOWN OTHERWISE, THIS DOCUMENT IS PROPRIETARY TO DIGITAL EQUIPMENT CORPORATION AND IS INTENDED FOR USE BY ITS FIELD SERVICE ORGANIZATION ONLY. FOR INFORMATION ON WRITING OR APPROVING A TECH TIP, SEE ADMINISTRATION TECH TIP NUMBER 2.

Page	Page Revision	Publication Date
------	---------------	------------------

FIELD SERVICE TECHNICAL MANUAL

SUMMARY

This summary is current to Speed Bulletin #164, February 2, 1981. It was originally intended that I should attach all known Tech-Tips to the back of the handbook as an appendix. The size of the resulting document prohibited that from happening. Use this summary to do your own research. I cannot stress enough the importance of regularly scanning the contents of each Speed Bulletin as they are released. Invest a few minutes of your time while you're near a fiche reader and save yourself an hour when you're on site without one.

Speed Bulletin #	Title	Tech Tip#	
119	RM02/03	Premature Bearing Failure	19
119	RM02/03	RM02/3 Will not run DECX-11	20
121	RM02/03	Write check error without Data check	21
121	RM02/03	RM03 Seek Incomplete/Misposition Prob.	22
145	RM02/03	Velocity Gain Adjustments	23
138	RM02/03	Head Alignment Tool Problem	24
138	RM02/03	Fault Latch Card	25
141	RM02/03	Vibration Sensitive Power Supplies	26
143	RM02/03	RM02/03/05/80 Module Compatibility	27
143	RM02/03	ASGV Versus 6SGV Speed Detect	28
143	RM02/03	RM02/03/05/80 RMA Backplane	29
145	RM02/03	Head Crashes	30
145	RM02/03	Dual Port Logic test part 2	31
161	RM02/03	RM02/03/05/80 Dual Port	32
162	RM02/03	240-220V H2 Power Conversion	33
143	RM05	Refer to RM03 TT#27	1
143	RM05	Refer to RM03 TT#29	2
161	RM05	Refer to RM03 TT#32	3
143	RM80	Refer to RM03 TT#27	1
143	RM80	Refer to RM03 TT#29	2
156	RM80	RM80-R80 Microcode Problems	3
161	RM80	Refer to RM03 TT#32	4
162	RM80	Site Preparation Information	5

Three additional Tech Tips are attached to the back of the book.
IMPORTANT....RM05 Head Crashes.