

**EMULEX STXX™
STI-COMPATIBLE TAPE
SUBSYSTEMS
INSTALLATION AND
MAINTENANCE MANUAL**



PE1450502-00, Rev A
October 1991

Information furnished in this document is believed to be accurate and reliable. However, Emulex Corporation assumes no responsibility for its use; nor for any infringements of patents or other rights of third parties which may result from its use. Emulex Corporation reserves the right to change product specifications at any time without notice.

The following trademarks of Emulex Corporation are used in this document:

Emulex®, ST8X, ST9X

The following are trademark acknowledgements:

DEC is a registered trademark and STI is a trademark of Digital Equipment Corporation.

WARNING: This equipment generates, uses, and can radiate radio frequency energy. If it is not installed and used in accordance with the instruction manual, it may cause interference to radio communications. This equipment has been type tested and found to comply with the limits for a Class A computing device pursuant to Subpart J of Part 15 of the Federal Communications Commission (FCC) Rules, which are designed to provide reasonable protection against such interference when operated in a commercial environment. Operation of this equipment in a residential area is likely to cause interference, in which case the user at his own expense will be required to take whatever measures may be required to correct the interference.

Shielded cables must be used between the board and attached peripherals to prevent radio frequency interference from this source.

The above statement applies to products marketed in the U.S.A.

WARNING: This digital apparatus does not exceed the Class A limits for radio noise emissions from digital apparatus as set out in the Radio Interference Regulations of the Canadian Department of Communications.

The above statement applies to products marketed in Canada.

Copyright 1991 Emulex Corporation. All Rights Reserved Worldwide. No part of this document may be reproduced by any means, nor translated nor transmitted to any electronic medium without the written consent of:

Emulex Corporation
3545 Harbor Boulevard
Costa Mesa, California 92626
(714) 662-5600
FAX (714) 241-0792
TLX 183627

Printed in U.S.A.

EMULEX STATEMENT OF WARRANTY

Effective: October 15, 1990

BASIC WARRANTY - In the absence of any optional warranty or continuing provisions extended by formal agreement, Emulex warrants its products in accordance with the schedules listed below.

CONTROLLERS - DATA COMMUNICATIONS PRODUCTS - Emulex warrants for a period of five (5) years from the date of shipment, that each product shall be free of defects in material and workmanship. These products include all disk and tape controllers, communication multiplexers, and communication servers.

SUBSYSTEMS - Emulex warrants for a period of twelve (12) months from the date of shipment, that each product shall be free of defects in material and workmanship. These products include magnetic disk and tape drives.

SOFTWARE WARRANTY - Emulex warrants for a period of ninety (90) days, from the date of shipment, that each software package supplied shall be free from defects and shall operate according to Emulex specifications under those Digital Equipment Corporation (DEC), IBM, Intel, and Unix, operating system versions supported by Emulex. Emulex does not warrant its software products under any operating system that has not been specifically identified. This warranty covers distribution media only; it does not cover on-site installation or integration.

MEDIA WARRANTY - Emulex warrants all media to be free of defects in material for a period of thirty (30) days from date of shipment.

CABLE WARRANTY - All Emulex-provided cables are warranted for ninety (90) days from date of shipment.

WARRANTY PROCEDURES - Warranty claims must be received by Emulex within the applicable warranty period. During the warranty period, if the customer experiences difficulties with an Emulex product and is unable to resolve the problem via phone with Emulex Technical Support, a Return Materials Authorization (RMA) number will be issued. No material will be accepted without an RMA number. The RMA number should be noted on the outside of the package. The customer is responsible for returning the product to Emulex, freight prepaid. Emulex, upon verification of warranty, will, at its option, either repair or replace the product in question, and return it to the customer freight prepaid. A returned product, or part thereof, for which Emulex provides a replacement, shall become the property of Emulex.

In the event product(s) returned under the provisions of this Warranty are subsequently determined by Emulex to

be functionally operational and in accordance with its published specifications, i.e. "No Defect Found" (NDF), Purchaser will be charged an NDF fee and the product shall be returned to Purchaser freight collect.

ON-SITE SERVICES ARE NOT INCLUDED AS A PART OF THESE WARRANTIES.

GENERAL TERMS - The above warranties shall not apply to expendable components such as fuses, bulbs, and the like, nor to connectors and other items not a part of the basic product. Nor does the foregoing warranty extend to experimental or developmental products, or to products that have been subject to misuse, neglect, accident, improper media usage or abuse; have been improperly wired, repaired, or altered by anyone other than Emulex; have been used in material violation of Emulex's operating instructions; or have had their serial numbers removed, defaced or altered. Emulex shall have no obligation to make repairs or to provide replacement for normal wear and tear, or necessitated in whole or in part by catastrophe, fault or negligence of the user; or improper or unauthorized use of the product; or use of the product in a manner for which it was not designed; or by causes external to the product, such as, but not limited to, power failure or air conditioning malfunction. Emulex's sole obligation hereunder shall be to repair or replace items covered under the above warranties. Purchaser shall provide for removal of the defective product, shipping charges for return to Emulex, and installation of its replacement. Above warranties are subject to change without notice.

THE EXPRESSED WARRANTIES SET FORTH IN THIS AGREEMENT ARE IN LIEU OF ALL OTHER WARRANTIES, EXPRESSED OR IMPLIED, INCLUDING WITHOUT LIMITATION, ANY WARRANTIES OF MERCHANTABILITY OR FITNESS FOR A PARTICULAR PURPOSE, AND ALL SUCH OTHER WARRANTIES ARE HEREBY DISCLAIMED AND EXCLUDED BY EMULEX. THE STANDARD EXPRESSED WARRANTIES ARE IN LIEU OF ALL OBLIGATIONS OR LIABILITIES ON THE PART OF EMULEX FOR DAMAGES, INCLUDING BUT NOT LIMITED TO SPECIAL, INDIRECT OR CONSEQUENTIAL DAMAGES ARISING OUT OF OR IN CONNECTION WITH THE USE OR PERFORMANCE OF THE PRODUCT.

Customer's sole and exclusive remedy for any breach of this warranty, whether in contract, tort, strict liability, or otherwise, shall be Emulex's obligation to repair or replace as set forth above.

Emulex is a registered trademark of Emulex Corporation, DEC is a registered trademark of Digital Equipment Corporation, IBM is a registered trademark of International Business Machines Corporation, Intel is a trademark of Intel Corporation, UNIX is a trademark of AT&T Bell Laboratories.



CONTENTS

PREFACE

About This Manual	ix
Audience	ix
Product Support	x
Related Documentation	x

Section 1 INTRODUCTION

1.1	Overview	1-1
1.2	General Description	1-2
1.3	Models and Accessories	1-3
1.4	Specifications	1-5

Section 2 INSTALLATION

2.1	Overview	2-1
2.2	Unpacking and Inspection	2-1
2.3	FCC Compliance	2-2
2.4	Installation Checklist	2-3
2.5	Selecting a Location	2-3
2.5.1	Subsystem Installation Site Requirements	2-4
2.6	Cabinet Installation	2-5
2.7	Cabling the Subsystem	2-7
2.7.1	Connect STI Cables	2-7
2.7.2	SCSI Bus Termination	2-8
2.7.3	AC Power Cabling	2-8
2.8	Power-Up and Initial Testing	2-9
2.9	Setting the Unit ID	2-10

Section 3 TROUBLESHOOTING

3.1	Overview	3-1
3.2	Troubleshooting	3-1
3.3	Running the ST8X/9X Internal Diagnostics	3-2
3.4	Using the HSC Diagnostics	3-4
3.4.1	Preparing to Run the HSC Diagnostics (ILTAPE and ILEXER)	3-4
3.4.2	HSC ILTAPE Diagnostics	3-5
3.4.2.1	HSC ILTAPE Diagnostic Test 1	3-5
3.4.2.2	HSC ILTAPE Diagnostic Test 5	3-6
3.4.3	HSC ILEXER Diagnostic	3-7

3.5	Preventive Maintenance	3-8
3.5.1	Cleaning the Tape Path	3-8
3.5.2	Tape Cartridge Maintenance Precautions	3-8
3.6	Service	3-9
Section 4	MAINTENANCE AND UPGRADES	
4.1	Overview	4-1
4.2	Replacing or Adding a Tape Drive	4-2
4.2.1	Configure the Tape Drive	4-4
4.2.2	Mount the Drive in the Chassis	4-6
4.3	Replacing the Controller Board	4-7
4.4	Replacing the Control Panel	4-8
4.5	Replacing the Backplane PCB	4-9

INDEX

FIGURES

Figure		Page
1-1	Subsystem Configuration	1-2
2-1	Installing the ST8X/9X Subsystem in a Cabinet	2-6
2-2	Rear Panel of the Subsystem	2-7
2-3	ST8X/9X Control Panel	2-10
4-1	Disassembling the ST8X/9X	4-2
4-2	Loosening the Drive Plate (Top View)	4-3
4-3	Configuration Switches for the ST8X Drives	4-5
4-4	Configuration Switches for the ST9X Drives	4-5
4-5	Front of Subsystem with Bezel Removed	4-7
4-6	The Mounting Screws on the Rear Connector Mounting Plate	4-9
4-7	Disassembling the Backplane (Interior View of Rear Panel)	4-9

TABLES

Table		Page
1-1	RETMA Cabinets for ST8X/9X Subsystem	1-3
1-2	ST8X/9X Host Adapter Cables and Accessories	1-4
1-3	Specifications of the ST8X/9X Subsystem	1-5
1-4	Specifications of the ST8X/9X Tape Drives	1-6
1-5	Specifications of the 8-mm Tape Cartridge	1-7
1-6	Specifications of the SDA Enclosures	1-7
3-1	Fault Codes	3-2
3-2	Error Code Descriptions	3-3
4-1	SCSI ID Switch Settings	4-4

About This Manual

This manual describes the procedures required to install, upgrade, and maintain the Emulex ST8X/9X series of STI-compatible tape subsystems. Operating instructions for these subsystems are contained in the appropriate User's Guides.

This manual contains the following subsections:

- **Section 1 (Introduction)** describes the ST8X/9X subsystem, provides a list of accessories, and lists the specifications of all models covered by this document.
- **Section 2 (Installation)** describes the physical installation of the subsystem in the equipment cabinets, cabling to the host, and initial power up and testing.
- **Section 3 (Troubleshooting)** provides some basic troubleshooting, and describes the internal diagnostics for the ST8X/9X, as well as the HSC ILTAPE and ILLEXER routines.
- **Section 4 (Maintenance and Upgrades)** gives procedures for replacing defective components and for adding a second tape drive.

The manual concludes with a subject index.

After reading this manual, please take a few minutes to complete and return the Reader's Comment card at the back of this manual. This will assist us in our continual effort to improve our documentation.

Audience

This manual is intended for qualified field service personnel only. Some of the procedures described in this document may subject the untrained technician to hazardous voltages that could result in personal injury.

Product Support

Emulex products are backed by a broad range of educational and technical support services. These services are available to you so that you can maximize your system performance and use Emulex products effectively.

For assistance in the continental United States, Alaska, and Hawaii, contact Emulex as follows:

Emulex Corporation
3545 Harbor Boulevard
Costa Mesa, California 92626
Telephone: (714) 662-5600
Outside California: (800) 854-7112

You may also use the following fax and telex numbers:

For ordering accessories:
FAX: (714) 241-0792, Attention: Order Administration
TLX: 183627, Attention: Order Administration

For technical assistance:
FAX: (714) 966-1299

Related Documentation

For operating instructions or other information on the Emulex ST8X/9X subsystems, refer to the following:

ST8X/9X STI-Compatible 8-mm Tape Subsystem User's Guide, P/N PE1450906-00

If you wish details about the related DEC diagnostic and utilities protocol, controllers, and tape subsystems, see the following DEC publications:

Storage System Diagnostic and Utilities Protocol, P/N AA-L620A-TK

HSC50/70 Hierarchical Storage Controller, User Guide, P/N AA-GMEAA-TK

*HSC50/70 Storage Controller
Installation Manual*, P/N EK-HSC50-IN
Service Manual, P/N EK-HSC50-SV

*HSC70 Storage Controller
Installation Manual*, P/N EK-HSC70-IN
Service Manual, P/N EK-HSC70-SV

TU81/TA81 Tape Subsystem, User Guide, P/N TK-TUA81-UG

1.1 Overview

This section describes the ST8X/9X series of STI-compatible tape subsystems and lists the specifications for each model. The section also provides a list of components supplied with each subsystem and a list of the accessories that may be required to install and maintain the subsystem.

WARNING!!

The ST8X/9X is designed to be installed and maintained only by qualified field service personnel. Opening the chassis of the subsystem may expose untrained personnel to dangerous shock.

All expressed and implied warranties concerning the mechanical and electrical reliability of this subsystem will be considered null and void if the subsystem is operated with any of the cover plates or outer shells removed. These covers must be in place to maintain proper air flow and cooling throughout the subsystem chassis.

1.2 General Description

The Emulex ST8X/9X subsystems consist of high-capacity tape drives with SCSI interfaces. These subsystems are connected through a tape adapter board to the Standard Tape Interface (STI) on DEC's Hierarchical Storage Controller (HSC), using Tape Mass Storage Control Protocol (TMSCP).

You may connect two tape drives to a single port on an HSC40/50/70 storage controller. The ST8X/9X can share the same DEC or Emulex tape data channel card with installed DEC tape drives. Because it is plug-compatible with the DEC TA series tape drives, the ST8X/9X supports any VAXcluster system without changes to systems or applications software.

The subsystem is contained in a 5.25-inch enclosure, which is mounted in a standard 19-inch rack. A single ST8X/9X may be connected to two HSCs to provide unattended backup storage to large VAXcluster disk systems. Figure 1-1 illustrates the subsystem configuration.

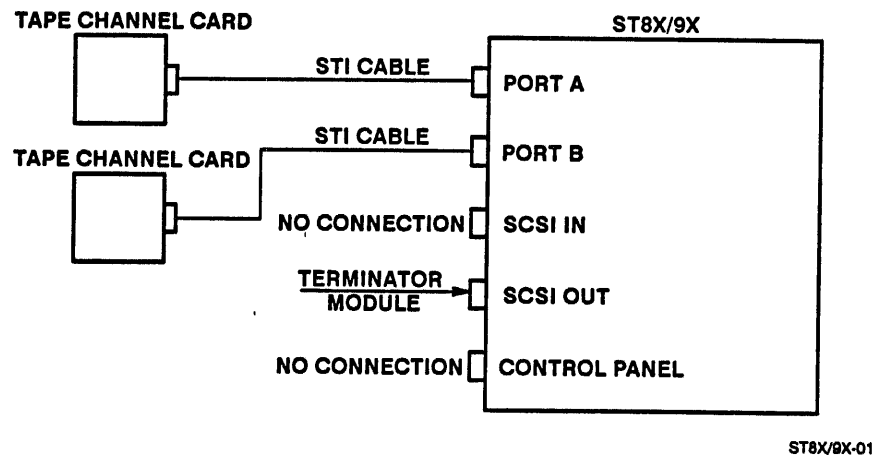

Figure 1-1. Subsystem Configuration

1.3 Models and Accessories

Depending on the model, the ST8X/9X subsystems are shipped with some or all of the following:

- Subsystem enclosure with one or two drives
- Rack mount hardware
- Emulex termination module
- Blank tape cartridge or cassette
- Cleaning cartridge or cassette

The ST8X and ST9X both use 8-mm, helical scan tape cartridges and differ only in their storage capacity per cartridge. The capacity for each model is as follows:

- ST8X - 2.5 Gbytes
- ST9X - 5.0 Gbytes

Table 1-1 lists the RETMA cabinets that may house the subsystem. Table 1-2 lists the various cables and accessories needed to install and maintain the subsystem.

Table 1-1. RETMA Cabinets for ST8X/9X Subsystem

Model	Description
SDA4	Standard 42-inch RETMA cabinet with power controller
SDA6	Standard 60-inch RETMA cabinet with power controller

Table 1-2. ST8X/9X Host Adapter Cables and Accessories

Part Number	Description
CT2000	Blank 8-mm tape cartridge
CK23	Cleaning tape (8-mm cartridge)
SDI-12	External STI/SDI cable, 12-foot
SDI-25	External STI/SDI cable, 25-foot
SDI-50	External STI/SDI cable, 50-foot
PE0910414-00	SCSI termination module

For ordering information contact Emulex Order Administration at the following address and telephone number:

Emulex Corporation
3545 Harbor Boulevard
Costa Mesa, CA 92626

Telephone: (714) 662-5600
Outside California: (800) 854-7112
FAX: (714) 241-0792, Attention: Order Administration
TLX: 183627, Attention: Order Administration

1.4 Specifications

Table 1-3 gives the specifications of the overall subsystem. Tables 1-4 and 1-5 give the specifications for the tape drives and cassette (cartridge) used in the ST8X/9X subsystems. Table 1-6 gives the electrical specifications of the SDA enclosures available from Emulex.

Table 1-3. Specifications of the ST8X/9X Subsystem

Parameter	Description
Dimensions	19 x 5.25 x 18 inches (457 x 133 x 483 mm)
Weight	30 pounds (13.6 kg)
Environment (Operating)	
Temperature	50° to 104°F (10° to 40°C)
Relative Humidity	20% to 80%, noncondensing
Altitude	0 to 10,000 ft (0 to 3,048 meters)
Vibration	0.25 g (17 - 500 Hz)
Shock	3 g peak, 5 msec
Environment (storage)	
Temperature	-40° to 140°F (-40° to 60°C)
Humidity	10% to 90%, noncondensing
Altitude	0 to 15,000 ft (0 to 4,575 meters)
Vibration	0.33 g (17 - 500 Hz)
Shock	40 g peak, 11 msec
Voltage Input	
100-240 VAC, 47-63 Hz	Autoranging; no voltage switch settings required
Power Consumption	
115 VAC	1.8 A, 100 W nominal, 342 BTU/hr
230 VAC	0.9 A, 100 W nominal, 342 BTU/hr
STI Interface	
Controller	DEC HSC 40/50/70, KDM70
Software Compatibility	DEC Standard Tape Interconnect (STI), DEC Tape Mass Storage Protocol (TMSCP)
Drive Address	0 to 254
Controller Connection	Two DEC STI connectors (Port A, Port B)

Table 1-4. Specifications of the ST8X/9X Tape Drives

Parameter	Description
ST8X Tape Drive	
Drive Interface	SCSI Tape
Data Transfer Rate	1.5 MBytes/sec, max., 246 KBytes/sec sustained
Data Buffer	256 KBytes
Tape Speed	Nominal: 0.5 inches/sec File Search: 5.0 inches/sec Rewind: 32.2 inches/sec
Reposition Time	1115 millisecc, max.
Drum Rotation Rate	1800 rpm
Linear Recording Density	Flux: 54,000 FR/inch. Bit: 43,200 bits/inch
Track Width	0.00098 inch
Track Density	819.35 tracks/inch
Physical Block Size	1024 data bytes + 400 ECC bytes
Logical Block Size	64 KBytes, max.
Reliability	
MTBF	30,000 hours, typical
MTTR	30 minutes
Data Reliability	Write: 1.0×10^{-12} bits. Read: 1.0×10^{-13} bits
ST9X Tape Drive	
Drive Interface	SCSI Tape
Data Transfer Rate	1.5 MBytes/sec, max., 500 KBytes/sec sustained
Data Buffer	1 MBytes
Tape Speed	Nominal: 0.44 inches/sec File Search: 75 times nominal speed Rewind: 48.8 inches/sec
Reposition Time	1115 millisecc, max.
Drum Rotation Rate	1831 rpm
Track Width	0.00061 inch
Track Density	1688.45 tracks/inch
Physical Block Size	1024 data bytes + 400 ECC bytes + 2 CRC bytes
Logical Block Size	240 KBytes, max.
Reliability	
MTBF	30,000 hours, typical
MTTR	30 minutes
Data Reliability	Write: 1.0×10^{-13} bits. Read: 1.0×10^{-13} bits

Table 1-5. Specifications of the 8-mm Tape Cartridge

Parameter	Description
Cartridge Type	Computer-grade 8-mm tape cartridge
Environment (Operating)	
Temperature	50° to 104°F (10° to 40°C)
Wet bulb temperature	70°F (26°C)
Relative Humidity	20% to 80%, noncondensing
Environment (storage)	
Temperature	41° to 90° F (5° to 32°C)
Wet bulb temperature	79°F (26°C)
Relative Humidity	20% to 60%, noncondensing

Table 1-6. Specifications of the SDA Enclosures

Parameter	Description
Input Voltage	
Domestic	115/208 VAC, three-phase, 30 A service required
International	230 VAC, single phase
SDA4	20 A service required
SDA6	30 A service required
Maximum Continuous AC Rating	
Domestic	115/208 VAC, three-phase
SDA4	6.8 Amps per phase
SDA6	10.2 Amps per phase
International	230 VAC, single phase
SDA4	12 Amps
SDA6	18 Amps
Power Receptacle	
Domestic	NEMA L21-30R
International	Per local requirements



2.1 Overview

This section describes the installation procedures for the ST8X/9X subsystems. Installation includes inspection, FCC compliance, cabinet mounting, and cabling. An installation checklist is provided to ensure that all steps are performed in the correct order.

2.2 Unpacking and Inspection

Emulex products are shipped in containers designed to provide full protection under normal shipping conditions. Immediately upon receipt, you should inspect the shipping container for evidence of damage. Any obvious damage to the container or equipment should be reported to the carrier company in accordance with the instructions in the container.

Unpack the subsystem chassis carefully. To avoid scratching the chassis, do not pierce the carton with a sharp object, such as a utility knife. Open the carton by cutting the sealing tapes along the side, and save it for repacking, in case you must reship the subsystem or any major component. After unpacking the ST8X/9X, inspect the entire subsystem for damage. Be sure there are no cracks or dents in the outer chassis and that all cables and connectors are intact.

2.3 FCC Compliance

The ST8X/9X was tested for FCC compliance for a Class A computing device in accordance with the specifications of Subpart J of Part 15 of FCC Rules. The subsystem was connected to other STI port devices with shielded cables. Emulex offers shielded cables, compatible with the ST8X/9X, in various lengths.

The ST8X/9X generates and uses radio frequency energy. If it is not installed and used in strict accordance with Emulex's instructions, it may cause EMI with radio and television reception. The user is responsible for proper installation, including maintaining the shield that has been built into equipment cabinets. The routing of cables to the ST8X/9X can have a major impact on the amount of EMI that is radiated by the system. Emulex is not responsible for any radio or TV interference caused by unauthorized modifications to the ST8X/9X.

If the ST8X/9X interferes with radio or television reception, as determined by turning the equipment on and off, take the following measures:

- Reorient the receiving antenna.
- Relocate the subsystem that contains the ST8X/9X, with respect to the receiver.
- Plug the subsystem into a different outlet so that the subsystem and receiver are on different branch circuits.
- Verify that the mounting screws and grounding wires on the compliant subsystem are tightly secured.

If necessary, consult the dealer or an experienced radio/television technician for additional suggestions. You may find the following booklet prepared by the FCC helpful: *How to Identify and Resolve Radio-TV Interference Problems*, Stock No. 004-000-00345-4, U.S. Government Printing Office, Washington, D.C. 20402.

2.4 Installation Checklist

Use the following checklist to ensure that you do not skip any of the steps when installing the subsystem.

INSTALLATION CHECKLIST

- 1. Select the location (subsection 2.5).
- 2. Install the ST8X/9X subsystem chassis in the RETMA cabinet (subsection 2.6).
- 3. Cable the ST8X/9X to the host (subsection 2.7).
- 4. Install the termination module on the rear of the subsystem if required (subsection 2.7.2).
- 5. Power up the subsystem and set the Unit ID (subsection 2.8 and 2.9).
- 6. Boot the system (refer to your host system manual).

2.5 Selecting a Location

The ST8X/9X is designed for installation in a 19-inch RETMA equipment cabinet in an air conditioned environment. Fans at the rear of the unit provide air circulation required for cooling. Do not obstruct these fans (i.e., do not install the unit with the rear of the chassis against the rear panel of the cabinet) or damage may result. The location must also provide access to the rear panel of the subsystem for connecting cables to the subsystem chassis. Mount the unit near the top of the equipment cabinet to provide easy access to the drives.

Select a location for the ST8X/9X that avoids the following harmful influences:

- High-powered electrical equipment
- Static electricity buildup
- Direct sunlight

2.5.1

Subsystem Installation Site Requirements

The subsystem must be installed in a room with adequate air conditioning. To determine the amount of cooling required in BTU/hour, multiply the maximum power, in watts, by 3.4134.

To determine site requirements for weight, heat output, and maximum AC power, refer to the Subsystem Specifications given in subsection 1.4. The weight of your subsystem must not exceed the strength of the flooring where it will be installed.

CAUTION! A fully loaded subsystem weighs in excess of 1000 pounds (454 kg). The system floor must be capable of supporting this weight.

2.6 Cabinet Installation

Mounting slides are provided with the ST8X/9X for installation in a 19-inch RETMA cabinet. Installation requires a standard screwdriver and a Phillips-head screwdriver. Refer to Figure 2-1 and use the following procedure:

WARNING!! When mounting the ST8X/9X in an empty cabinet, be sure to support the cabinet to prevent it from falling forward and causing personal injury and damage to the equipment.

1. Attach the inner slide rails to the ST8X/9X chassis.
2. Attach the outer slide rails to the cabinet.
 - a. Locate and mark the tenth hole from the top of the mounting rails. If the ST8X/9X is being mounted below another module, locate and mark the tenth hole from the bottom of that module.
 - b. Insert the slide rails in the cabinet so that the upper slot in the mounting brackets are aligned with the designated holes in the cabinet rails.
 - c. Fasten the rails to the cabinet using 10/32 x 1-inch screws and bar nuts as shown in Figure 2-1.
3. Slide the rails forward until they lock in place.
4. Align the slides on the ST8X/9X with the slide rails in the cabinet. Slide the chassis into the rack-mount rails, and press the unit into the cabinet until it stops.
5. If you meet resistance when sliding the chassis into the rack, confirm that the flanges on the chassis are mated properly with those on the rack.

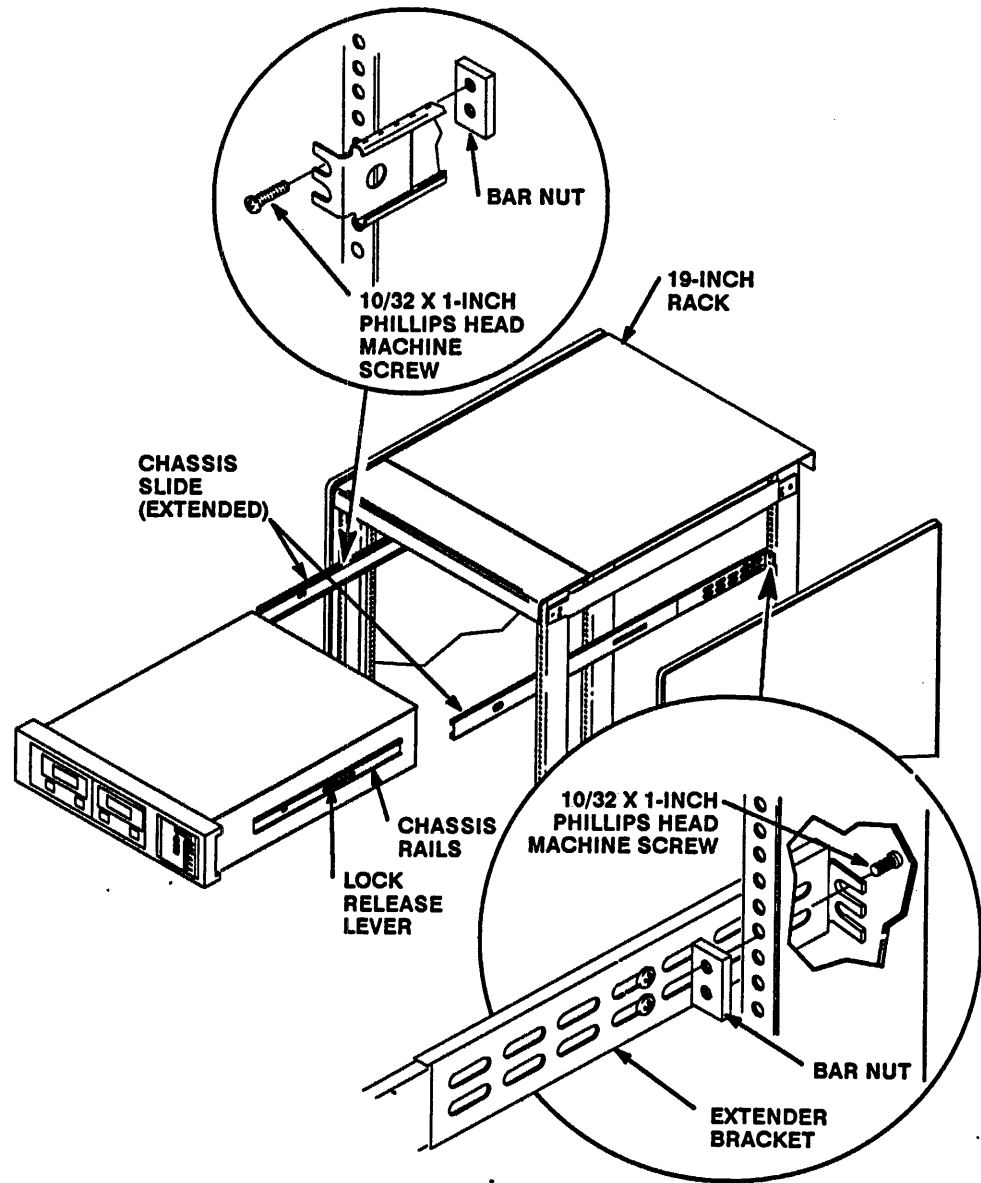

ST8X-04

Figure 2-1. Installing the ST8X/9X Subsystem in a Cabinet

2.7 Cabling the Subsystem

Cabling the subsystem requires connecting the STI cable between the host and the ST8X/9X subsystem, terminating the SCSI bus and connecting the power cord.

2.7.1 Connect STI Cables

The ST8X/9X is connected to the tape data channel card in the HSC through an STI bus. Use either standard DEC BC26V-STI cables or the Emulex cables listed in Table 1-2. Refer to Figure 2-2 and connect the cables as follows:

1. Plug the STI cable connector into the first available tape data channel receptacle on the HSC cabinet I/O bulkhead. STI cables enter the cabinet from the bottom.
2. Tighten the two screws that hold the STI cable connector shield in place.
3. Install additional STI cables for each ST8X/9X subsystem, in sequence.
4. Route the STI cables to the tape drive cabinet, and feed them through the access hole in the base of the cabinet.
5. Plug the first STI cable into Port A on the ST8X/9X enclosure. Tighten the screws on the connector shield.
6. Secure the cables to the side rail with tie wraps. Be sure to leave a two-foot service loop between the tie wrap and the end of the cable.
7. If the subsystem is dual ported to a second tape data channel card, repeat steps 5 and 6 for the Port B cables.

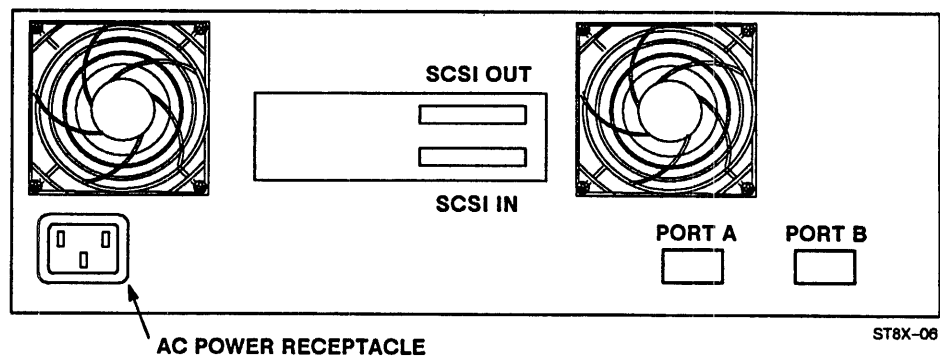

Figure 2-2. Rear Panel of the Subsystem

2.7.2 SCSI Bus Termination

The SCSI bus must be terminated at both ends of the bus cable. An internal terminator is installed on the controller board within the ST8X/9X chassis.

Install the SCSI termination module on the SCSI OUT connector of the ST8X/9X chassis.

2.7.3 AC Power Cabling

A standard IEC380 AC power receptacle mounted on the rear chassis of the ST8X/9X (see Figure 2-2) permits it to mate with most power distribution units. The AC input is autoranging: it operates with 100 to 240 VAC and 50 to 60 Hz.

CAUTION! Plug the ST8X/9X into a power distribution unit in the subsystem cabinet. The use of AC wall outlets for powering any of the subsystem components may result in increased data errors.

2.8 Power-Up and Initial Testing

When AC power is applied, the LED display on the ST8X/9X control panel (Figure 2-3) should read 314, indicating the unit is performing the power-up self-test.

If the display flashes a three-digit code other than 314, the controller has detected a fault. Refer to Section 3 for an explanation of the error codes. If the front panel does not illuminate at all, check your power source and breakers.

2.9 Setting the Unit ID

Before the ST8X/9X can communicate with the host, it must have a unit ID assigned to it. In multi-drive configurations, the unit ID distinguishes one drive from another. The unit ID may be any number from 0 through 254 and is set on the three-position display of the control panel.

After the unit passes the power-up self-test, the LED display indicates the current unit ID. To change the ID, use the following procedure:

1. Ensure that neither A nor B port is selected (switches not illuminated).
2. Press the On Line and Fault/Reset switches simultaneously. Hold both switches in for five seconds. The BOT light begins flashing, indicating that the unit ID may be programmed.

NOTE: Do not press the Fault/Reset switch first as this takes the unit offline and ejects the tape cartridge.

3. Set the base unit ID for the first drive as follows. The tape adapter will automatically assign the ID for the second drive (if present).
 - a. Observe the three right-hand digits of the LED display.
 - b. Use the Port A and Port B switches, respectively, to increment or decrement the displayed ID.
4. When the desired ID is displayed, press the On Line and Fault/Reset switches simultaneously and hold them in for five seconds. The On Line light begins flashing and the LED Display shows the Unit Mode code.
5. Use the Port A or Port B switch to set the displayed Unit Mode to 00.
6. Repeat step 4 to retain the unit ID in nonvolatile memory. The LED display now shows the new unit ID.

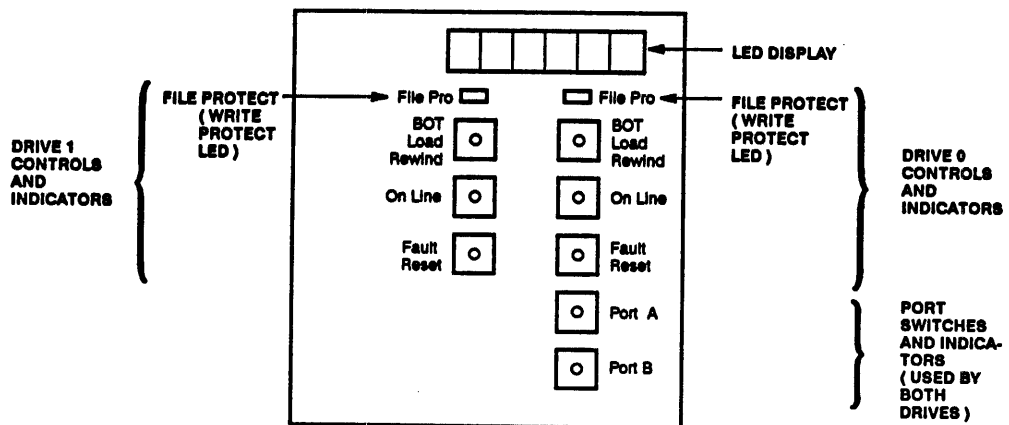

ST8X-07

Figure 2-3. ST8X/9X Control Panel

3.1 Overview

This section describes basic troubleshooting procedures, the power-on self-tests, and the HSC diagnostics used to identify and correct most problems associated with ST8X/9X subsystems. The section also provides information for obtaining service and technical assistance from Emulex.

3.2 Troubleshooting

If you experience problems with the subsystem, first review the installation procedures in Section 2 to ensure that all components were installed properly. Next, check the following items:

1. Cabling, terminators, and power cords are connected properly, and no connector pins are bent.
2. All power sources are working.
3. The HSC controller and ST8X/9X have both completed their self-test successfully.
4. Tape cartridges are installed properly (see the user manual).
5. You have observed the rules about cleaning and handling tape cartridges (subsection 3.5).

If the items listed are correct, use the procedures described in this section to identify the problem. If the problem cannot be resolved, replace either the controller board or tape drive(s), or contact Emulex service as described in subsection 3.6.

3.3 Running the ST8X/9X Internal Diagnostics

When power is applied to the unit, the display shows 000000 for five seconds, and then flashes 314 during the power-up self-test. If the self-tests complete successfully, the display then shows the unit ID number.

If an error occurs, the fault indicator is illuminated, and the display flashes the fault code. Table 3-1 lists fault codes and their definitions. The drive will remain in the error mode until the problem is corrected.

When a fault occurs, press the Reset switch, taking the unit offline. If the error is cleared, the unit returns online. If you press the Reset switch when the BOT indicator is illuminated the unit unloads any tape in the drive.

Table 3-1. Fault Codes

Code	Fault Condition
--	Daisy-chain configuration error or drive not found
306	Microprocessor fault
307	STI error
308	Read/Write unsafe error
309	Read/Write command error
311	Write Enable and Write Protect asserted error
312	Microprocessor hardcore test error
314 or 316	Self-test and drive configuration (not an error)
317	EPROMs do not match controller board (ST9X EPROMs have been installed in an ST8X)

If the display continues to show 000000 after ten seconds, check all cables for bent pins, incorrect connections, or improper termination of the SCSI bus.

During normal operation, the tape cartridge drive reports errors based on the drive's Sense Key information. These error codes are listed in Table 3-2. For example, if the display flashes 834 during tape drive operation, a Hardware error (last digit = 4) occurred during a Position tape command (first digit = 8).

Table 3–2. Error Code Descriptions

Error Code	Description
First Digit Error Code	
4XX	Read
5XX	Write
6XX	Rewind
7XX	Write tape mark
8XX	Position tape
9XX	Error recovery or end of rewind
Last Digit Error Code	
XX3	Media error
XX4	Hardware error
XX5	Illegal byte in CDB
XX8	Blank Tape

3.4 Using the HSC Diagnostics

The two HSC diagnostics: Inline Tape (ILTAPE) and Inline Exerciser (ILEXER) provide a method for testing the tape transport and Read/Write operations of the subsystem. To use these diagnostics, first set the ST8X/9X to the test mode as follows:

1. Power up the ST8X/9X. After the unit passes the power-on self-tests, the LED display shows the unit ID for each drive.
2. Be sure that neither A nor B port is selected. Simultaneously press the right-hand drive Fault/Reset and On Line switches. When the BOT indicator begins flashing, you may program the unit ID.
3. Repeat step 2. The On Line indicator begins flashing, and the LED display shows the drive mode.
4. Use the Port A and Port B switches, respectively, as Increment and Decrement switches to set the code to 31 (test mode) in the LED display.

After you complete the tests, use the Port A and Port B switches to return the unit to the normal operating mode (mode 00). Simultaneously press the right-hand drive Fault/Reset and On Line switches again. The front panel returns to normal operation, with the unit address displayed.

3.4.1 Preparing to Run the HSC Diagnostics (ILTAPE and ILEXER)

After setting the ST8X/9X to the test mode, prepare for running both HSC diagnostics (ILTAPE and ILEXER) as follows:

1. Load a write-enabled tape cartridge into the tape drive.
2. Place the tape drive online. The On Line indicator illuminates.
3. Enable the appropriate port (A, B, or both) on the ST8X/9X control panel.
4. Boot the HSC.

To run the HSC ILTAPE diagnostics, see subsection 3.4.2. To run the HSC ILEXER diagnostics, see subsection 3.4.3. For more information on these diagnostics, refer to the HSC documentation.

3.4.2 HSC ILTAPE Diagnostics

The HSC ILTAPE Diagnostics tests the ST8X/9X transport functions and verifies streaming operations. Run ILTAPE on both STI ports of a dual-ported system.

Use the following procedure to run two passes each of the HSC ILTAPE Diagnostic, Tests 1 and 5:

1. Press the INIT button on the HSC control panel to begin booting. The following message appears:

```
INIPIO-1 Booting...
```

When HSC booting is complete, the following message appears:

```
HSC Version XXX dd-mmm-yy hh:mm:ss System n
```

2. Press <CTRL-Y>. The following prompt appears:

```
HSCXX> (XX may be 40, 50 or 70)
```

3. Initiate HSC Diagnostic Tests 1 and 5 by entering the following sequence at the prompts:

```
HSCXX> R ILTAPE
```

```
ILTAPE>D>hh:mm Execution starting
```

```
DRIVE UNIT NUMBER (U) []? Tnnn
EXECUTE FORMATTER DEVICE INTEGRITY TEST (Y/N) [Y]? N
EXECUTE TEST OF TAPE TRANSPORT (Y/N) [N]? Y
IS SCRATCH MEDIA MOUNTED (Y/N) []? Y
```

At this point, Tests 1 and 5 require different commands. To run Test 1, see subsection 3.4.2.1; for Test 5, see subsection 3.4.2.2.

3.4.2.1 HSC ILTAPE Diagnostic Test 1

Run two passes of ILTAPE Test 1 by entering the following sequence at the prompt:

```
Functional Test Sequence Number (0 thru 5) [1]? 1
ENTER CANNED SEQUENCE RUN TIME IN MINUTES (D) [1]? 1
SELECT DENSITY (0=ALL, 1=1600, 2=6250) [0]? 0
ILTAPE>D>FIXED SPEEDS AVAILABLE:
ILTAPE>D>(1) 025 IPS
ILTAPE>D>(2) 075 IPS
SELECT FIXED SPEED (D) [0=AUTOMATIC]? 0
DATA PATTERN NUMBER (1,2,3,4) [3]? 3
SELECT RECORD SIZE (greater than 0) (D) [8192]? 8192
ITERATIONS (D) [1]? 2
```

3.4.2.2 HSC ILTAPE Diagnostic Test 5

Run two passes of ILTAPE Test 5 by entering the following sequence at the prompt:

```
Functional Test Sequence Number (0 thru 5) [1]? 5
SELECT DENSITY (1=800, 2=1600, 3=6250) [3]? 3
ILTAPE>D>FIXED SPEEDS AVAILABLE:
ILTAPE>D> (1) 025 IPS
ILTAPE>D> (2) 075 IPS
SELECT FIXED SPEED (D) [0=AUTOMATIC]? 0
DATA PATTERN NUMBER (0,1,2,3,4) [3]? 3
ITERATIONS (D) [1]? 1
```

NOTE: ILTAPE Test 5 performs operations which run to the end of the tape. When using 112m (2-hour) tape cartridges, this test may time out before the ST8X/9X reaches the end of the tape. Therefore, a shorter tape length, such as 28m (30-minute), is recommended for this test.

3.4.3 HSC ILEXER Diagnostic

The Inline Exerciser (ILEXER) Diagnostic exercises the unit by writing and reading a data pattern. When you plan to use both STI ports, run ILEXER on each. No errors are allowed except for those pertaining to possible defects in the tape. Use the following procedure to run the ILEXER Diagnostic for 10 minutes:

1. Press the INIT button on the HSC control panel to begin booting. The following message appears:

```
INIPIO-1 Booting...
```

When HSC booting is complete, the following message appears:

```
HSC Version XXX dd-mmm-yy hh:mm:ss System n
```

2. Press <CTRL-Y>. The following prompt appears:

```
HSCXX> (XX may be 40, 50 or 70)
```

3. Run ILEXER by entering the following sequence at the prompt:

```
HSCXX> R ILEXER
```

```
ILEXER>D>hh:mm Execution Starting
```

```
Drive Unit Number (U) []? Tnnn
Is a Scratch Tape Mounted (Y/N) []? Y
Are You Sure (Y/N) [N]? Y
Data Pattern Number (16-22) (D) [21]? 21
Density (1=800, 2=1600, 3=6250) [3]? 3
Select Automatic Speed Management (Y/N) [N]? N
ILEXER>D>Fixed Speeds Available:
ILEXER>D> (1) 025 IPS
ILEXER>D> (2) 075 IPS
Select Fixed Speed (D) [1]? 1
Record Length in Bytes (2 to 12288) (D) [8192]? 8192
Data Compare (Y/N) [N]? Y
Another Drive (Y/N) []? N
Run Time in Minutes (1 to 32767) [10]? 10
Hard Error Limit (D) [20]? 20
Narrow Report (Y/N) [N]? N
Enable Soft Error Reports (Y/N) [N]? N
```

3.5 Preventive Maintenance

A regular maintenance schedule is important to keep your subsystem in peak condition. If the tape path is not cleaned on a scheduled basis, dust and residue will accumulate on the tape heads, causing data errors and unreliable backups. The appropriate cleaning kit is provided with your ST8X/9X subsystem. You may order additional kits from Emulex (see Table 1-2).

Do not use cleaning kits other than those provided by Emulex. Other kits, including earlier approaches used by the drive manufacturer, are unacceptable and will void your warranty.

3.5.1 Cleaning the Tape Path

When you insert the cleaning cartridge into the ST8X/9X, the cleaning material moves through the tape path for 15 seconds, removing tape residue and dust. When the cartridge is ejected, your subsystem is ready for operation. When the entire tape length has been used, the tape will be ejected as soon as it is inserted. At this point, a new kit is required.

Use the head-cleaning cartridge after reading or writing 30 Gbytes of data (approximately 30 hours of operation) or every 30 days, whichever comes first. If you experience read/write performance problems, run one or two cleaning passes. Instructions for using the cleaning kit are provided with the kit.

Do not rewind and reuse a cleaning kit. This will re-introduce contaminants.

3.5.2 Tape Cartridge Maintenance Precautions

The following precautions should be observed to maintain the cartridges in good working condition:

- Keep the tape cartridge in a controlled environment. The environmental specifications are given in Table 1-5.
- Do not place the tape cartridge near a magnetic field or in sunlight.
- Store cartridges vertically and in the case provided.
- Do not touch the tape inside the cartridge.

3.6 Service

If the problem persists after following the procedures in this section, you can get help by calling Emulex Technical Support at the phone number given below. If you determine that the subsystem contains a defective component, return the component to an authorized Emulex repair center for service.

Do not return a component without authorization. Before returning a product to Emulex, whether it is under warranty or not, you must contact the factory or the factory representative for return-shipment instructions and a Return Materials Authorization (RMA) number. A component returned for service without an authorization will be returned to the owner at the owner's expense. Outside the United States, contact the distributor from whom the subsystem was initially purchased. In the continental United States, Alaska, and Hawaii, contact:

Emulex Technical Support
3545 Harbor Boulevard
Costa Mesa, CA 92626

Telephone: (714) 662-5600
(1-800-854-7112 outside California)
FAX: (714) 966-1299

After you have received an RMA, package the subsystem peripheral device, preferably using the original packing material, and send it, *postage paid and insured*, to the address provided by the Emulex representative.



4.1 Overview

This section details the procedures for installing and removing the tape drive, controller board, backplane, and front control panel of the ST8X/9X subsystems.

CAUTION! All expressed and implied warranties concerning the mechanical and electrical reliability of this subsystem will be considered null and void if the subsystem is operated with any of the cover plates or outer shells removed from the subsystem. These covers must be in place to maintain proper air flow and cooling throughout the subsystem chassis.

4.2 Replacing or Adding a Tape Drive

These procedures require a standard screwdriver and a Phillips-head screwdriver.

WARNING!! To protect both yourself and the equipment, turn off system power before removing the cover or front bezel.

Figure 4-1 illustrates the disassembly of the ST8X/9X. Use the following procedures to replace a drive or install a second drive:

1. Be sure the subsystem is dismantled from the operating system and taken offline.
2. Power down the subsystem, and unplug the unit from all electrical outlets.
3. Remove the top cover by removing fourteen screws and lifting the cover.
4. Remove the front bezel by grasping its sides and pulling forward.
5. Disconnect the drive power cable and the 50-conductor, daisy-chained SCSI cable for each drive. Fold back the SCSI cable to reveal two captive drive-plate screws.

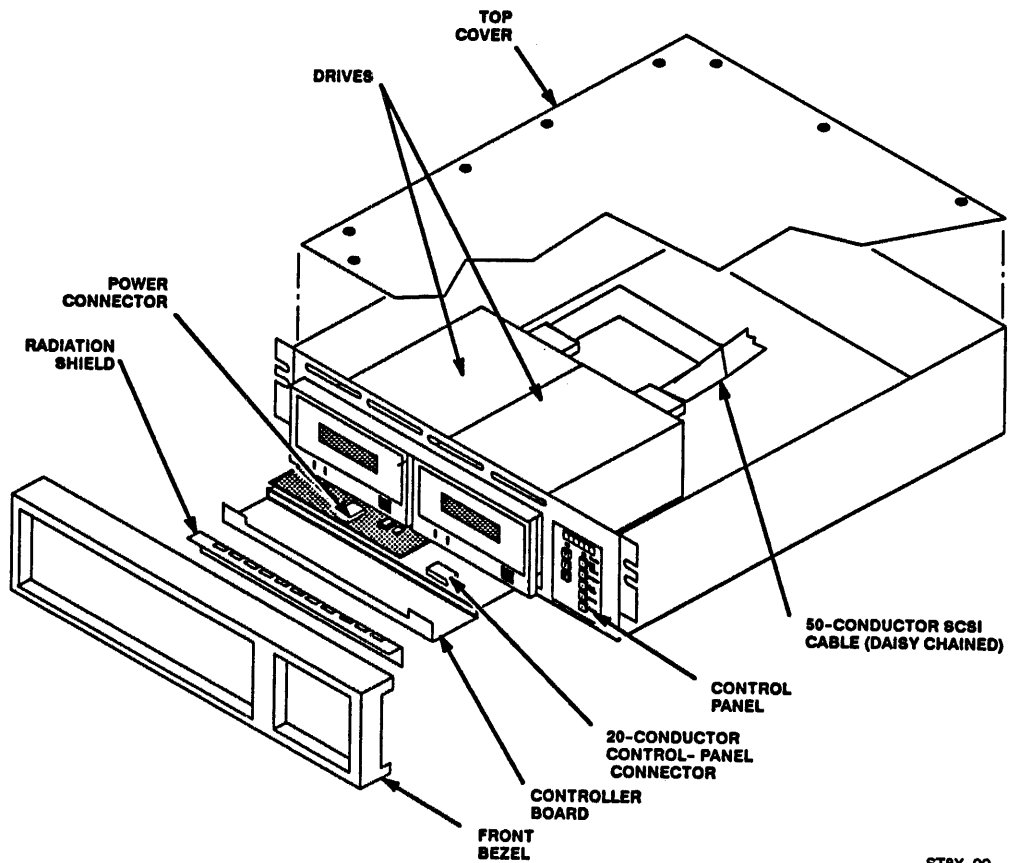
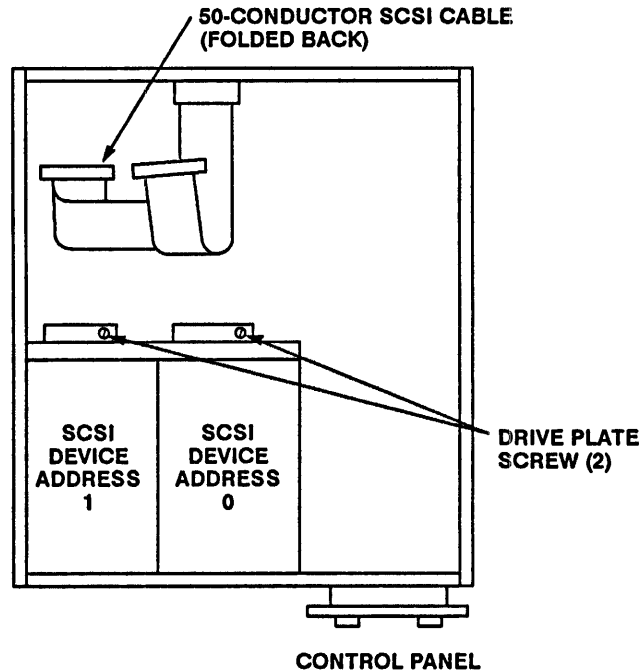

Figure 4-1. Disassembling the ST8X/9X

6. Loosen the two captive drive-plate screws that hold the drive plate in place (refer to Figure 4-2), and slide the drive plate out the front of the subsystem chassis.



ST8X-10

Figure 4-2. Loosening the Drive Plate (Top View)

7. Add or remove the filler plate as required:
 - If you are adding a drive, remove the filler plate from the drive plate. Use the provided screws to attach the drive to the drive plate.
 - If you are removing a drive, use the provided screws to install the filler plate in the drive plate.

4.2.1 Configure the Tape Drive

Before the new or replacement tape drive is installed, it must be set to the correct SCSI ID and be terminated properly. Figures 4-3 and 4-4 show the location of the SCSI ID switches for the ST8X and ST9X, respectively. Table 4-1 lists the SCSI ID switch settings for each address.

1. Set the SCSI ID as follows:
 - For a single tape drive, or the first drive in a two-drive unit, set the SCSI ID to 0.
 - Set the second drive (if present), to ID 1.

Table 4-1. SCSI ID Switch Settings

SCSI ID	SW1-1	SW1-2	SW1-3
0	OFF	OFF	OFF
1	ON	OFF	OFF

2. Remove the termination resistors from the drive. These resistors are located near the SCSI ID switch as shown in the following figures.

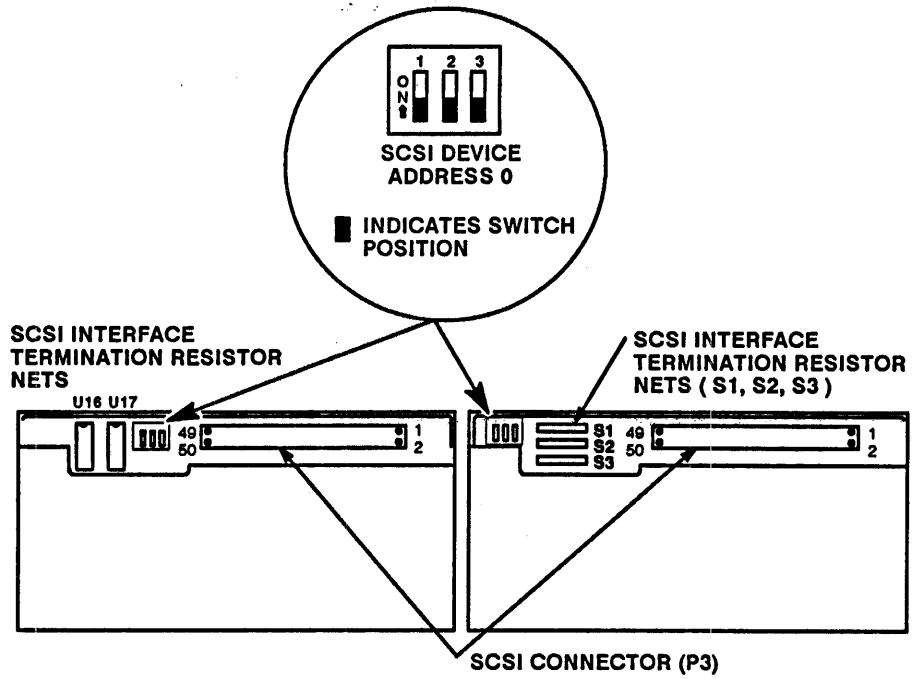

DTXX-08

Figure 4-3. Configuration Switches for the ST8X Drives

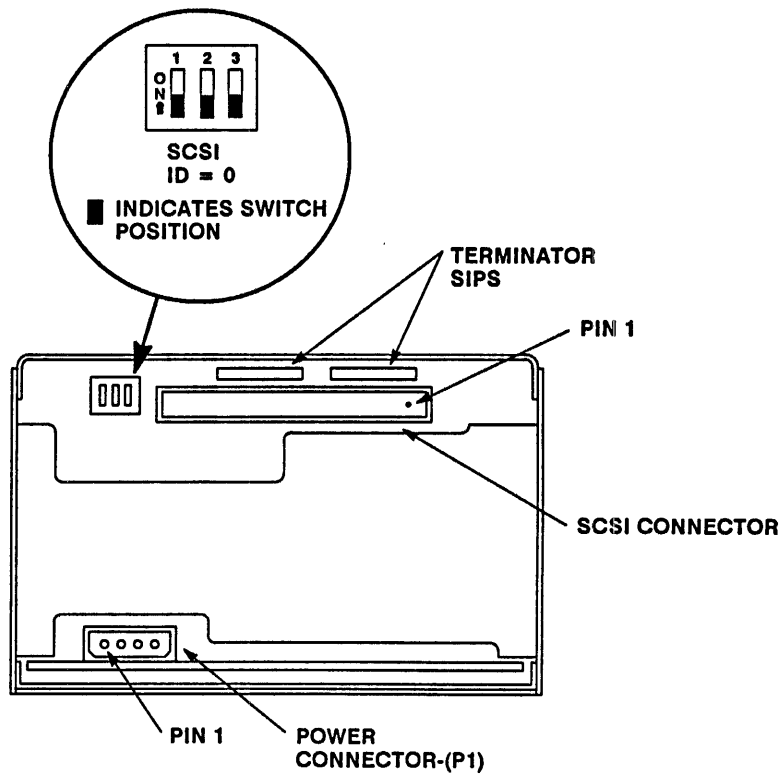

DTXX-09

Figure 4-4. Configuration Switches for the ST9X Drives

4.2.2 Mount the Drive in the Chassis

1. Refer to Figure 4-1 and re-install the tape drive(s) and the drive plate in the chassis by tightening the two captive drive-plate screws.
2. Reconnect the drive power cable and 50-conductor, daisy-chained SCSI cable.
3. Re-install the top cover and secure it with the fourteen screws removed earlier.
4. Replace the front bezel by pressing it on the front of the unit until it locks in place.
5. Connect the power cord and power up the unit.
6. Run the diagnostics described in Section 3 to verify operation of the new or additional tape drive.
7. Place the subsystem online and issue a mount command to reconnect it to the operating system.

4.3 Replacing the Controller Board

Use the following procedure to replace the controller board:

WARNING!! To protect both yourself and the equipment, turn system power OFF before removing the front bezel.

1. Be sure the subsystem is dismantled from the operating system and taken offline.
2. Power down the subsystem, and unplug the unit from all electrical outlets.
3. Remove the front bezel by grasping its sides and pulling forward.
4. Refer to Figure 4-5, and loosen the five captive screws on the radiation shield at the bottom of the tape drive(s).
5. Use a standard screwdriver, and carefully pry the controller board forward a couple of inches to gain access to the power connector and front panel control connector (see Figure 4-1).
6. Remove the power cable and front panel control cable.
7. Pull the controller board out the rest of the way.
8. Install the new controller board by following the removal procedure in the reverse order. Re-align each connector carefully with the mating connector on the board. Align the pin-1 stripe of the front panel control cable with the pin-1 notch on the mating connector.

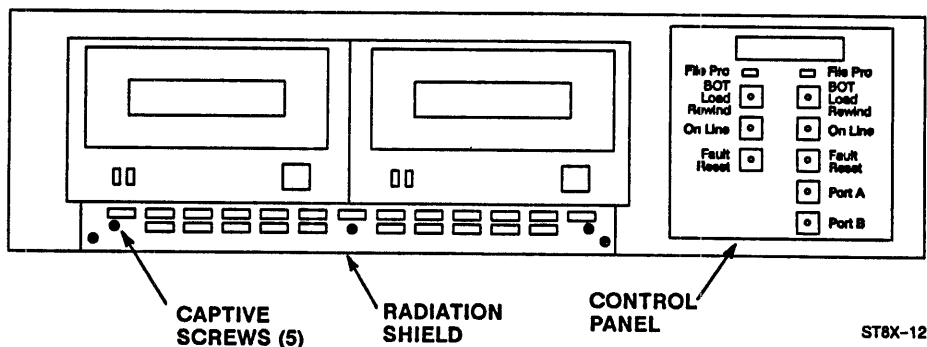

Figure 4-5. Front of Subsystem with Bezel Removed

9. Connect the power cord and power up the unit.
10. Place the subsystem online and issue a mount command to reconnect it to the operating system.

4.4 Replacing the Control Panel

WARNING!! To protect both yourself and the equipment, turn system power OFF before removing the bezel.

Use the following procedure to replace the control panel:

1. Be sure the subsystem is dismantled from the operating system and taken offline.
2. Power down the subsystem and unplug the unit from all electrical outlets.
3. Remove the front bezel by grasping its sides and pulling forward.
4. Remove the front control panel by pulling it forward. Disconnect the cable from the 20-conductor, control-panel connector at the front of the controller board (see Figure 4-1).
5. Install the new control panel by reversing this procedure.
6. Connect the power cord and power up the unit.
7. Place the subsystem online and issue a mount command to reconnect it to the operating system.

4.5 Replacing the Backplane PCB

Use the following procedure to replace the backplane printed circuit board (PCB).

WARNING!! To protect both yourself and the equipment, turn system power OFF before removing the bezel.

Use the following procedure to install or remove the backplane:

1. Power down the subsystem, unplug the unit from all electrical outlets, remove the subsystem from the cabinet, and take off its top cover.
2. Carefully remove the two 50-pin flat ribbon cables on the backplane PCB by pressing on the release handles. Carefully remove the five power cables.
3. Remove the four screws from the rear connector mounting plate (see Figure 4-6).
4. Remove the ten screws from the backplane PCB (see Figure 4-7) and carefully remove the backplane.
5. Install the new backplane by reversing the procedure, taking care to reconnect the cables properly.

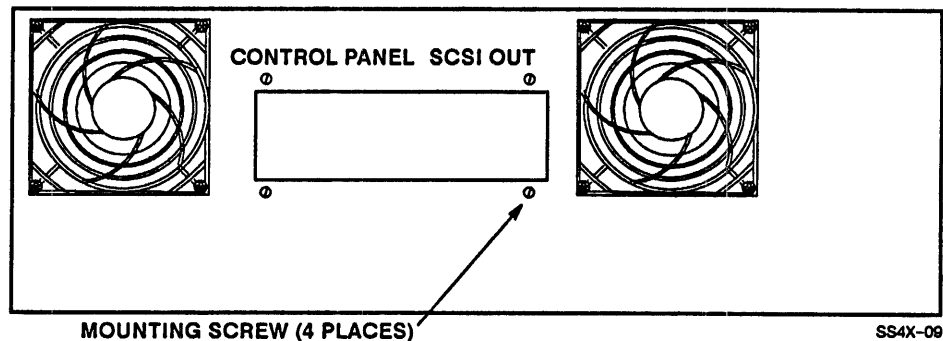

Figure 4-6. The Mounting Screws on the Rear Connector Mounting Plate

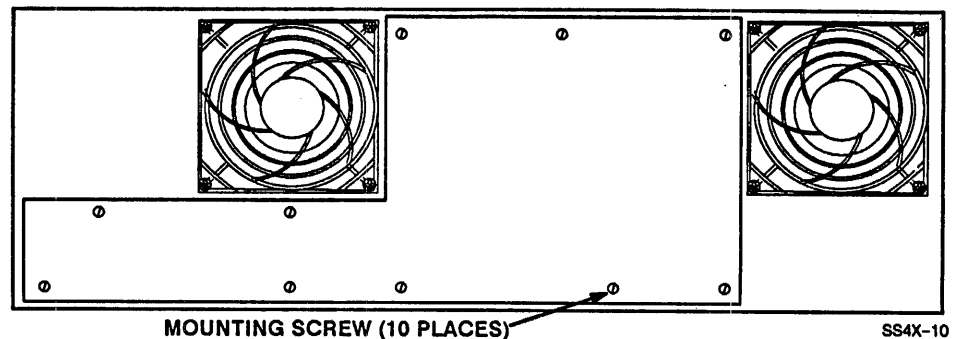

Figure 4-7. Disassembling the Backplane (Interior View of Rear Panel)



A

Address, TMSCP. *See* Drive address
Audience, ix

B

Backplane PCB, replacing, 4-9

C

Cabinet installation, 2-5
Cabling
 connecting AC, 2-8
 STI, 2-7
Cartridge
 cleaning kit, 3-8
 handling precautions, 3-8
Checklist, installation, 2-3
Configurations of the subsystem, 1-2
Control panel, replacing, 4-8
Controller board, replacing, 4-7
Cooling requirements, 2-4

D

DEC documentation, x
Diagnostics
 ILEXER, 3-4, 3-7
 ILTAPE, 3-5
 preparing to run, 3-4
Documentation, related, x
Drive. *See* Tape drive
Drive address (Unit ID), 2-10

E

Emulex, Service (Technical Support), 3-9
Error code description, 3-3

F

Faults
 fault codes, 3-2
 fault indicator, 3-2
FCC compliance, 2-2

H

HSC (Hierarchical Storage Controller), x, 1-2
 Diagnostics (ILTAPE and ILEXER), 3-4

I

ILEXER (HSC Inline Exercise Diagnostic), 3-4, 3-7
ILTAPE (HSC Inline Tape Diagnostic), 3-4, 3-5
Inspecting the subsystem, 2-1
Installation checklist, 2-3
Installation requirements, 2-4
Installing the subsystem, 2-1
Intended audience, ix
Interchange, tape cartridge specification, 1-7

L

LED display, 3-2
Location requirements, 2-3

M

Maintenance, preventive, 3-8
Modes of operation (test or normal), 3-4

N

Normal mode (mode 00), 3-4

P

Power
 connecting AC, 2-8
 requirements of SDA enclosure, 1-7
 subsystem requirements, 1-5

Problems with your subsystem, 3-1

Product support, x

R

Reset switch, 3-2

RMA (Return Materials Authorization), 3-9

S

SCSI, bus termination, 2-8

SCSI ID, setting on tape drives, 4-4

Service (Technical Support), 3-9

Site requirements, 2-4

Specifications

SDA enclosure, 1-7

subsystem, 1-5

tape cartridge, 1-7

tape drives, 1-6

STI (Standard Tape Interface), 1-2

T

TA series tape drives, 1-2

Tape drive, installing or removing, 4-1

Technical Support, x, 3-9

Termination, resistors on drives, 4-4

Test mode (mode 31), 3-4

TMSCP (Tape Mass Storage Control Protocol), 1-2

Troubleshooting, 3-1

TU81/TA81, x

U

Unit ID

See also Drive address
programming in ST8X/9X, 2-9

V

VAXcluster system, 1-2



EMULEX STXX™
STI-Compatible Tape Subsystems
Installation and Maintenance Manual
PE1450502-00, Rev A

Reader's Comments

Your comments and suggestions will help us in our continuous effort to improve the quality and usefulness of our publications. Mail this form using the self-mailer, or send it by FAX, Attention: Technical Publications (714) 668-6818.

Product Model Number _____

What is your general reaction to this manual? Is it complete, accurate, well organized, well written, etc.? Is it easy to use? _____

What features are most useful? _____

Does it satisfy your needs? _____

What problems or errors have you found in the manual? _____

What improvements would you like to see? _____

Name _____	Street _____
Title _____	City _____
Company _____	State/Country _____
Department _____	Zip _____

Additional copies of this document may be ordered from your Emulex sales representative or write:

Emulex Corporation
3545 Harbor Boulevard
P.O. Box 6725
Costa Mesa, CA 92626

Fold Here and Tape-DO NOT Staple

Do Not Tear - Fold Here



NO POSTAGE
NECESSARY
IF MAILED
IN THE
UNITED STATES

BUSINESS REPLY MAIL
FIRST CLASS MAIL PERMIT NO. 202 COSTA MESA, CA

POSTAGE WILL BE PAID BY ADDRESSEE

ATTN: TECHNICAL PUBLICATIONS
EMULEX CORPORATION
3545 HARBOR BOULEVARD
PO BOX 6725
COSTA MESA CA 92628-9928

