



3270 Information
Display System

3174 Subsystem
Control Unit

Customizing Guide

Configuration Level A/S Release 4

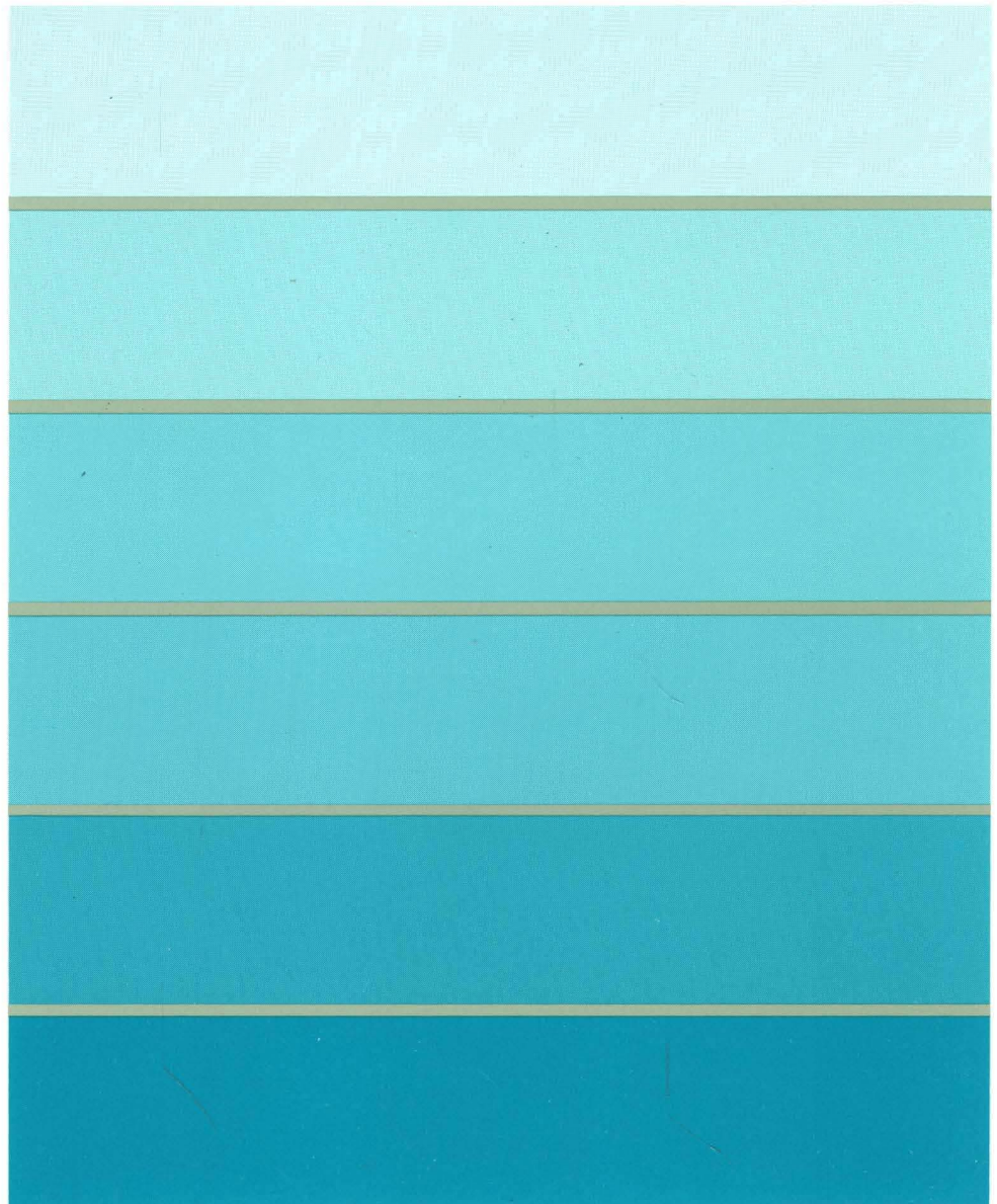



3270 Information
Display System

3174 Subsystem
Control Unit

Customizing Guide

Configuration Level A/S Release 4

GA23-0214-3

Part Number
25F7651

File Number
36/38/370/4300/8100/3174-09

United States

Warning: This equipment generates, uses, and can radiate radio frequency energy and if not installed and used in accordance with the instructions manual, may cause interference to radio communications. It has been tested and found to comply with the limits for a Class A computing device pursuant to Subpart J of Part 15 of FCC Rules, which are designed to provide reasonable protection against such interference when operated in a commercial environment. Operation of this equipment in a residential area is likely to cause interference in which case the user at his own expense will be required to take whatever measures may be required to correct the interference.

Additional IBM Statement

This warning is also applicable to all attaching units produced for use in the U.S.A. that have been manufactured after December 31, 1980. A notice of compliance has been affixed within the customer access area of all affected units.

United Kingdom

Warning: This IBM product is made to high safety standards. It complies inherently with Telecommunications safety standard BS6301. It is not designed to provide protection from excessive voltages appearing externally at its interfaces. Therefore, when this product is connected to a public telecommunications network via any other equipment, and you connect to this product items not supplied by IBM United Kingdom Ltd., you must comply with mandatory telecommunications safety requirements.

You may do this either by choosing products which also are approved as complying to BS6301 or British Telecom Technical Guide No. 26, or by the use of approved safety barriers. Consult the local office of your public telecommunications operator, for advice and permission to make the connections.

Fourth Edition (October 1988)

This major revision obsoletes and replaces GA23-0214-2. See "Summary of Changes" on page vii for the changes made to this manual. Other changes or additions to the text and illustrations are indicated by a vertical line to the left of the change.

Changes are made periodically to the information herein; before using this publication in connection with the operation of IBM systems or equipment, consult your IBM sales representative or the latest *IBM System/370, 30xx, and 4300 Processors Bibliography*, GC20-0001, for the editions that are applicable and current.

References in this publication to IBM products, programs, or services do not imply that IBM intends to make these available in all countries in which IBM operates. Any reference to an IBM licensed program in this publication is not intended to state or imply that only IBM's licensed program may be used. Any functionally equivalent program may be used instead.

Publications are not stocked at the address given below. Requests for IBM publications should be made to your IBM representative or to the IBM branch office serving your locality.

A form for readers' comments is provided at the back of this publication. If the form has been removed, address comments to IBM Corporation, Department E02, P.O. Box 12195, Research Triangle Park, N.C., U.S.A. 27709-0990. IBM may use or distribute whatever information you supply in any way it believes appropriate without incurring any obligation to you.

Choosing the Right Book from the 3174 Library

The 3174 library contains information for installing, customizing, operating, maintaining, and programming the data stream for the 3174 control unit. The list below shows the manuals you need to perform these tasks.

To Organize Library Materials:

Binders and Inserts, SBOF-0089
Binder, SX23-0331
Inserts, SX23-0332

To Become Familiar with the 3174:

Master Index, GC30-3515
3270 Information Display System Introduction, GA27-2739

To Prepare Your Site for the 3174:

Site Planning, GA23-0213
Physical Planning Template, GX27-2999

To Set Up and Operate the 3174:

Models 1L, 1R, 2R, and 3R User's Guide, GA23-0337
Models 51R, 52R, and 53R User's Guide, GA23-0333
Models 81R and 82R User's Guide, GA23-0313

To Plan for and Customize the 3174:

Customizing Guide, GA23-0214
Central Site Customizing User's Guide, GA23-0342

To Install Features or Convert Models on the 3174:

Encrypt/Decrypt Adapter Customer Installation and Removal Instructions,
GA23-0262
Fixed Disk and Diskette Drive Customer Installation and Removal Instructions,
GA23-0263
Terminal Multiplexer Adapter Customer Installation and Removal Instructions,
GA23-0265
Model Conversion Customer Setup Instructions, GA23-0295
*IBM Token-Ring Network 3270 Gateway Customer Installation and Removal
Instructions*, GA23-0329
Storage Expansion Feature Customer Installation and Removal Instructions,
GA23-0330
Communications Adapter Customer Installation and Removal Instructions,
GA27-3830

To Plan for and Use the Asynchronous Emulation Adapter Feature:

Asynchronous Emulation Adapter Introduction, GA23-0331
Terminal User's Reference for Expanded Functions, GA23-0332

To Use the Multiple Logical Terminals Function:

Terminal User's Reference for Expanded Functions, GA23-0332
Customizing Guide, GA23-0214

To Perform Problem Determination:

Customer Extended Problem Determination, GA23-0217
Status Codes, GA27-3832

To Obtain Data Stream Programming and Reference Information:

Functional Description, GA23-0218
Data Stream Programmer's Reference, GA23-0059
Character Set Reference, GA27-3831

To Perform Maintenance (Service Personnel):

Models 1L, 1R, 2R, and 3R Maintenance Information, SY27-2572
Models 51R, 52R, and 53R Maintenance Information, SY27-2573
Models 81R and 82R Maintenance Information, SY27-2584

To Find Translations of Safety Notices:

Safety Notices, GA27-3824

Preface

This book explains how to customize the microcode for the IBM 3174 Subsystem Control Unit. It presents the background information required for customization planning and explains the procedures of planning and customizing the Control disk.

Who This Book Is For

This book is written for the person who plans for customizing and the person who customizes the microcode on the Control disk for the 3174 Subsystem Control Unit. In various establishments, different people do this job: systems programmers, systems analysts, systems specialists, software specialists, communication analysts, operations analysts, network planners, or telecommunication specialists. The person who customizes the Control disk should be familiar with working at a 3270-type display station.

How to Use This Book

This book has four parts and three appendixes:

Part 1. Introduction (Chapters 1 and 2): This part explains what is involved in customizing the microcode for the 3174 Subsystem Control Unit.

If you are using this book for the first time, read this part. It gives you an overview of how to plan for customizing using the configuration worksheets and how to perform the customizing procedures at a display station (terminal). It then points you to the parts of the book that explain how to plan for customizing, how to customize, and how to perform the associated utility functions.

Part 2. Planning (Chapters 3 through 11): This part provides the planning information you need to customize the microcode. It describes filling out the worksheets (from Part 4) and helps you answer the configuration questions. Two quick-reference guides help you to find planning information quickly. See "Quick-Reference Guides" on page vi.

Part 3. Procedures (Chapters 12 through 19): This part presents the procedures for customizing the Control disk. It describes entering the information from the filled-out worksheets at a display station. A quick-reference guide helps you to find customizing information quickly. See "Quick-Reference Guides" on page vi.

Part 4. Worksheets (Chapter 20): This chapter contains the configuration worksheets. You may want to reproduce them in quantity so that you will always have an unused set of worksheets available for future planning.

Appendix A: This appendix describes the interutility checking program and explains how to use it.

Appendix B: This appendix identifies customizing keyboard and keypad layouts.

Appendix C: The Limited Function Utility Disk and how it differs from the Utility Disk is discussed in this appendix.

Quick-Reference Guides

Included with this book are three quick-reference guides:

- 3174 Quick-Reference Guide for Planners
- Quick Reference to 3174 Configuration Questions
- 3174 Quick-Reference Guide for Customizing.

You can use these guides to find specific planning and customizing information quickly. These guides are printed on card stock and may be used as divider pages at the beginning of Parts 2 and 3. They may also be removed from the binder for ease of use.

The Guide for Planners provides a quick guide to planning for customization.

The Quick Reference to 3174 Configuration Questions lists the possible responses for each of the configuration questions, which worksheets they appear on, and the page number they appear on in this publication.

The 3174 Quick-Reference Guide for Customizing provides a quick guide to customizing.

Related Publications

While planning to customize, you may wish to refer to one of these publications for more detailed information on a particular subject:

IBM 3270 Information Display System:

Introduction, GA27-2739

3174 Character Set Reference, GA27-3831

X.25 Operation, GA23-0204

3174 Subsystem Control Unit:

Models 1L, 1R, 2R, and 3R User's Guide, GA23-0337

Models 51R, 52R, and 53R User's Guide, GA23-0333

Models 81R and 82R User's Guide, GA23-0313

Customer Extended Problem Determination, GA23-0217

Functional Description, GA23-0218

Site Planning, GA23-0213

Central Site Customizing User's Guide, GA23-0342

Asynchronous Emulation Adapter: Introduction, GA23-0331

Terminal User's Reference for Extended Functions, GA23-0332

7232 Dual Control Unit Terminal Multiplexer (RPQ 8K1670) User's Guide, GA23-0345.

Summary of Changes

Fourth Edition (October 1988)

This revision of the *IBM 3174 Subsystem Control Unit Customizing Guide* contains new or revised information on:

- Fixed disk drives
- Multiple Logical Terminals (MLT) level enhancements
- Support of Country Extended Code Page (CECP)
- Limited Function Utility (LFU) disk
- Transmission enhancements for SDLC, BSC, and X.21 protocols
- The Media Management Utility
- Support for Central Site Change Management (CSCM)
- Token-Ring Network 3270 Gateway
- Keyboard definition enhancements.

Technical changes or additions to the text and illustrations are indicated by a vertical line to the left of the change.

Contents

Part 1. Introduction

Chapter 1. For First-Time Users	1-1
The 3174 Subsystem Control Unit	1-3
What Is Customizing?	1-4
How Do I Plan for Customizing?	1-4
What Microcode Will You Use?	1-5
What Are Microcode Releases?	1-6
How Do You Customize a Control Disk?	1-6
What Is the Master Menu?	1-8
What Is the Customize Control Disk Menu?	1-11
The Customizing Panels	1-13
Chapter 2. Keeping Records	2-1
Methods of Record-Keeping	2-3
Local Copy	2-3
Planning Worksheets	2-5
Duplicate Diskettes	2-5
Using the Copy Procedure to Manage Customization Data	2-6

Part 2. Planning

Chapter 3. Planning to Configure	3-1
Getting Ready to Plan to Configure	3-3
Why Do You Need to Plan?	3-3
How Do You Plan?	3-3
Display Compatibility Requirements	3-4
Can You Use a Pattern Control Diskette?	3-4
Configuration and Reconfiguration Planning Procedure	3-5
Storage Planning Procedure	3-7
Configuration Questions	3-10
099: Product Assistance Data	3-10
100: 3174 Model Designation	3-10
101: Host Attachment	3-11
104: Control Unit Address	3-12
105: Upper Limit Address	3-14
106: Token-Ring Network Address of the 3174	3-15
107: Token-Ring Network Address of the Gateway	3-16
108: Unique Machine Identifier	3-16
110: Multiple Logical Terminals (MLTs) Configuration Level	3-17
116: Individual Port Assignment	3-20
117: Port Assignment	3-20
118: Port Address	3-20
121: Keyboard Language and Character Set I/O Interface Code	3-20
123: Country Extended Code Page Support	3-22
125: Miscellaneous Feature Options	3-22
127: Response Time Monitor (RTM) Definition	3-24
128: RTM Boundaries and Interface Specification	3-25
132: Alternate Base Keyboard Selection	3-25

136: Modifiable Keyboards: Standard Layouts	3-26
137: Modifiable Keyboard: Modified Layouts	3-27
138: Modifiable Keypad: Standard Layouts	3-28
141: Magnetic Character Set	3-28
165: Compressed Program Symbols	3-29
166: Attribute Select Keyboard	3-29
168: Additional Extension-Mode Key Definition (Personal Computers)	3-29
173: Distributed Function Terminal (DFT) Options	3-30
175: Distributed Function Terminal (DFT) Password	3-32
176: BSC Enhanced Communication Option: Distributed Function Terminals	3-32
178: 7232 Dual Control Unit Terminal Multiplexer Switching	3-33
213: Between Bracket Printer Sharing	3-33
215: Physical Unit Identification	3-33
220: Alert Function	3-34
222: Support of Command Retry	3-34
223: Attention Delay Value	3-36
224: Mode of Data Transfer	3-36
225: Channel Burst Size	3-36
310: Connect-Data-Set-to-Line (CDSTL) Operation	3-37
313: NRZ or NRZI Encoding	3-37
317: Telecommunication Facilities	3-38
318: Full- or Half-Speed Transmission	3-39
332: X.25 Options	3-39
340: RTS Control Response Options	3-39
360: X.21 Switched Retry (Models 2R, 52R, and 82R Only)	3-40
361: X.21 Switched Retry Timing (Models 2R, 52R, and 82R)	3-40
362: X.21 Switched Options	3-41
365: X.21 Data Transfer Delay (Models 2R, 52R, 82R)	3-42
367: X.21 Switched Short-Hold Mode	3-43
368: X.21 Switched Short-Hold Mode Dial Number	3-43
370: Maximum Inbound I-Frame Size	3-43
380: Maximum Receive I-Frame Size	3-44
381: Token-Ring Network Maximum In	3-44
382: Maximum Transmission I-Frame Size	3-45
383: Token-Ring Network Maximum Out	3-45
Planning to Reconfigure	3-46
Host Panel	3-46
117: Port Assignment Panel	3-46
128: RTM Panel	3-46
332: X.25 Options Panel	3-46
What's Next?	3-46
Chapter 4. Planning for Port Assignment	4-1
Getting Ready to Plan for Port Assignment	4-3
Which Response to Question 116 Should You Specify?	4-3
A Response of 0	4-3
A Response of 1	4-4
A Response of 2	4-4
Considerations	4-5
For DFT	4-5
For CUT	4-5
For AEA	4-5
Who Assigns the Terminals to the Ports?	4-6
Completing Worksheet 12—117: Port Assignment When 116=1	4-9
Completing Worksheet 12—117: Port Assignment When 116=2	4-10

118: Port Address Table	4-11
Changing Port Assignments	4-12
What's Next?	4-12
Chapter 5. Planning for Response Time Monitor (RTM)	5-1
Getting Ready to Plan for Response Time Monitor	5-3
An Overview of Response Time Monitor	5-3
127: RTM Definition	5-3
First-Digit Response	5-4
Second-Digit Response	5-5
128: RTM Boundaries and Interface	5-7
How Is Response Time Measured?	5-9
Sample Boundary Specifications	5-9
Valid Boundaries	5-9
Invalid Boundaries	5-10
Filling Out Worksheet 13—128: RTM	5-11
Changing the RTM Specifications	5-12
What's Next?	5-12
Chapter 6. Planning for X.25	6-1
Getting Ready to Plan for X.25	6-3
An Overview	6-3
332: X.25 Options	6-3
Filling In Worksheet 14—X.25 Options	6-5
400: Network Type	6-5
401: Circuit Type	6-5
402: Logical Channel Identifier	6-5
403: Logical Link Control	6-6
409: X.25 Keyboard Support Options	6-6
420: Incoming Call Options	6-7
421: Outgoing Call Options	6-9
423: Host DTE Address (HNAD)	6-10
424: 3174 DTE Address	6-10
430: Negotiated Packet Size (NPKT)	6-10
431: Packet Sequence Numbering	6-11
432: Negotiated Window Size (NWND)	6-11
433: K-Maximum Out	6-11
434: Nonstandard Default Packet Size (DPKT)	6-11
435: Nonstandard Default Window Size (DWND)	6-12
440: Throughput Class Negotiation (TCLS)	6-12
441: Closed User Group (CUG)	6-13
442: Recognized Private Operating Agency (RPOA)	6-13
450: Link Level Transmit Timeout	6-13
451: Number of Retries	6-14
452: Connection Identifier Password (CID)	6-14
Changing the X.25 Options	6-15
What's Next?	6-15
Chapter 7. Planning for Central Site Change Management (CSCM)	7-1
Getting Ready to Plan Central Site Change Management	7-3
An Overview of CSCM	7-3
Filling In Worksheet 24—Common SNA	7-4
500: CSCM Unique	7-4
501: Network ID (NETID)	7-5
502: Logical Unit Name (LUNAME)	7-5
What's Next?	7-5

Chapter 8. Planning for the Asynchronous Emulation Adapter	8-1
Getting Ready to Plan for the Asynchronous Emulation Adapter	8-3
Terminology	8-3
Considerations	8-5
MLT	8-5
Storage	8-5
Overview	8-6
ASCII Display Stations Supported by the AEA	8-7
Filling Out Worksheet 16—3270 Attachment Diagram	8-8
Step 1. Fill In the Host Station Set Name and Station Set Number Columns	8-8
Step 2. Fill In the Station Type Column	8-9
Step 3. Fill In the Default Destination Columns	8-10
Step 4. Fill In the Station Set Name Column	8-12
Step 5. Fill In the Port Set Name Column	8-13
Filling Out Worksheet 17—ASCII Attachment Diagram	8-14
Step 1. Fill In the Host Station Set Name and Station Set Number Columns	8-14
Step 2. Fill In the Station Type Column	8-14
Step 3. Fill In the Default Destination Column	8-16
Step 4. Fill In the Port Type	8-18
Step 5. Fill In the Modem Type	8-20
Step 6. Fill In the Station Set Name Column	8-22
Step 7. Fill In the Port Set Name Column	8-24
Numbering the AEA Station Sets on the Attachment Diagrams	8-25
Filling Out the AEA Worksheets	8-27
Step 1. Fill Out Worksheet 18—AEA Configure	8-27
700: Configure the AEA Feature	8-27
701: Password for ASCII Display Stations on Switched Lines	8-27
Step 2. Fill Out Worksheet 19—AEA Port Set	8-27
Step 3. Fill Out Worksheet 20—AEA Port to Port Set Map	8-28
Step 4. Fill Out Worksheet 21—AEA Station Set	8-30
721: Station Set Name	8-32
722: Station Type	8-32
723: Port Set Name	8-33
725: Host Connection Menu Option	8-33
731: Flow Control Type	8-33
732: XON/XOFF Transmission Resumption Trigger	8-34
733: Line Speed	8-35
734: Line Speed (ASCII Host Upper Limit)	8-35
735: Parity	8-36
736: Stop Bits	8-36
737: Maximum Modem Line Speed	8-36
741: Switched Disconnect Timeout (3270 Hosts Only)	8-37
742: Inactivity Timeout	8-37
743: Prompt for Universal/Specific Keyboard Map	8-38
751: Data Stream Supported by the ASCII Host	8-38
752: ASCII Host Phone Number	8-38
761: Auto XON/XOFF (DEC VT100 Data Stream)	8-40
762: Wraparound Option (DEC VT100 Data Stream)	8-40
763: New Line Option (DEC VT100 Data Stream)	8-41
764: Margin Bell (DEC VT100 Data Stream)	8-41
771: Automatic Line Feed for Cursor Control (IBM 3101 Data Stream)	8-41
772: Carriage Return/Carriage Return—Line Feed Selection (IBM 3101 Data Stream)	8-42
773: Automatic New Line for Cursor Control (IBM 3101 Data Stream)	8-42
774: Scrolling (IBM 3101 Data Stream)	8-42
775: Line Turnaround Character (IBM 3101 Data Stream)	8-42

781: Attached Printer Prompt	8-42
782: Use of Form Feed	8-43
783: Page Length	8-43
Step 5. Fill Out Worksheet 22—AEA Default Destination	8-43
What's Next?	8-45
Chapter 9. Planning the Token-Ring Network 3270 Gateway	9-1
Getting Ready to Plan for the Token-Ring Network 3270 Gateway	9-3
Filling In the Token-Ring 3270 Gateway Worksheets	9-3
900: Token-Ring Network Address for the Gateway	9-3
905: Ring Error Monitor (REM)	9-3
908: Link Subsystem Name	9-4
940: Ring Address Assignment	9-4
941: Ring Transmission Definition	9-5
What's Next?	9-6
Chapter 10. Planning to Define the Printer Authorization Matrix (PAM)	10-1
Getting Ready to Plan the Printer Authorization Matrix	10-3
Do You Need a Printer Authorization Matrix?	10-3
A Sample PAM	10-7
Filling Out Worksheet 15—Printer Authorization Matrix (PAM)	10-8
What's Next?	10-8
Chapter 11. Planning to Modify Keyboards	11-1
Getting Ready to Plan the Modification of Keyboards	11-3
Overview of the Modify Keyboards Procedure	11-3
Planning Procedure	11-4
Step 1. Locate the Worksheets You Plan to Use	11-4
Step 2. At the Top of the Worksheet, Circle the Keyboard ID	11-4
Step 3. Specify New Layout or Update	11-5
Step 4. Specify the Keyboard Type	11-5
Step 5. Specify the Keypad Type	11-5
Step 6. Specify the Keyboard Language	11-5
Step 7. Fill Out the Keyboard Changes Chart	11-5
Step 8. Indicate with an X Which Keys Will Be Affected	11-9
Step 9. Give a Copy of the Completed Worksheets to the Customizer	11-9
Restrictions	11-9
General	11-9
Local Functions	11-10
APL	11-11
Nomenclature Presentation	11-11
Customizing	11-11
Setting Up the Terminal Keyboards	11-12
Two-Language Modification	11-12
Examples of Two-Language Modification	11-13
Keyboard Languages and I/O Interface Codes Supported	11-17
What's Next?	11-19

Part 3. Procedures

Chapter 12. How to Display the Master Menu	12-1
Getting Ready to Display the Master Menu	12-3
Overview	12-3
Before Starting the Alt 1 IML Procedure	12-4
If IMLing from a diskette drive	12-5

If IMLing from a fixed disk drive	12-5
How to Insert Diskettes – Models 1L, 1R, 2R, and 3R	12-6
How to Insert Diskettes – Models 51R, 52R, 53R, 81R, and 82R	12-6
How to Display the Master Menu – Remote (R) Models	12-7
How to Display the Master Menu – Model 1L	12-10
Chapter 13. How to Customize the Control Disk	13-1
Customize the Control Disk Overview	13-3
Typing in Responses to the Configuration Questions	13-3
Printing a Local Copy	13-3
Correcting Invalid Responses	13-4
Getting Ready to Customize the Control Disk	13-5
PF Keys	13-5
Step 1. Select 'Customize the Control Disk' on the Master Menu	13-6
Step 2. Verify Drives	13-6
Step 3. Select a Customizing Procedure	13-8
Configure Overview	13-9
How to Configure the Control Disk	13-10
Getting Ready to Configure the Control Disk	13-10
PF Keys	13-10
Step 1. Select 'Configure' on the Customize Control Disk Menu	13-12
Step 2. Enter Responses on the Model/Attach Panel	13-13
Step 3. Enter Responses on the Host Panel	13-14
Step 4. Enter Responses on the Token-Ring Network Gateway Panels	13-15
Step 5. Enter Responses on the Common SNA Panel	13-18
Step 6. Enter Responses on the 117: Port Assignment Panel	13-19
Step 7. Enter Responses on the 128: RTM Panel	13-21
Step 8. Enter Responses on the 332: X.25 Options Panel	13-23
Step 9. Press PF12 to Save the Panels	13-24
What's Next?	13-25
How to Define the Printer Authorization Matrix (PAM)	13-26
Getting Ready to Define the PAM	13-26
PF Keys	13-26
Step 1. Select 'Define PAM' on the Customize Control Disk Menu	13-28
Step 2. Enter Responses on the Printer Authorization Matrix Panel(s)	13-29
Step 3. Press PF12 to Save the PAM Panel(s)	13-30
What's Next?	13-30
Merge RPQ Overview	13-31
RPQ Utility Panel	13-31
RPQ Merge Panel	13-33
How to Merge RPQs	13-34
Getting Ready to Merge RPQs	13-34
PF Keys	13-34
Step 1. Select 'Merge RPQ' on the Customize Control Disk Menu	13-35
Step 2. Verify Drives	13-36
Step 3. Select Include, Omit, or Delete Options	13-37
Step 4. Select Merge RPQs Option	13-38
What's Next?	13-39
Modify Keyboards Overview	13-40
How to Modify Keyboards	13-41
Getting Ready to Modify Keyboards	13-41
PF Keys	13-41
Step 1. Fill Out Keyboard Layout Worksheets	13-42
Step 2. Select 'Modify Keyboards' on the Customize Control Disk Menu	13-42
Step 3. Modify the Master Panel	13-43
Step 4. Modify Keyboard Panels	13-46

Step 5. Use the Master Panel to Check Your Results	13-54
Step 6. Exit from the Procedure	13-54
What's Next?	13-55
How to Configure the AEA	13-56
Getting Ready to Configure for the AEA	13-56
PF Keys	13-56
Step 1. Select 'AEA Configure' on the Customize Control Disk Menu	13-58
Step 2. Enter Responses on the AEA Configure Panel	13-59
Step 3. Enter Responses on the AEA Port Set Panel	13-60
Step 4. Enter Responses on the AEA Port to Port Set Map Panel	13-61
Step 5. Enter Responses on the AEA Station Set Panels	13-62
Step 6. Enter Responses on the AEA Default Destination Panel	13-64
Step 7. Press PF12 to Save the Panels	13-65
What's Next?	13-66
Step 4. Complete Customizing the Control Disk	13-67
What's Next?	13-68
Chapter 14. How to Merge DSL Code	14-1
Getting Ready to Merge DSL Code	14-3
Merge DSL Code Overview	14-3
When Must You Merge the DSL Code?	14-3
Merge Procedure	14-5
PF Keys	14-5
Step 1. Select 'Merge DSL' on the Master Menu	14-5
Step 2. Verify Drives	14-6
Step 3. Select the Merge/Delete Option	14-8
Step 4. Making Multiple Merges from the To Disk	14-9
What's Next?	14-10
Chapter 15. How to Copy Files	15-1
An Overview of the Copy Files Procedure	15-3
Drive Choices	15-4
How to Determine Maintenance and Microcode Levels	15-6
Full Copy	15-7
Modify and Copy	15-8
Copy Customizing Data	15-9
Copy PAM	15-9
Copy Patches	15-10
Copy Modified Keyboards	15-10
Copy RPQs	15-10
Copy Procedure	15-11
PF Keys	15-11
Step 1. Select 'Copy Files' on the Master Menu	15-11
Step 2. Select the Copy Procedure from the Copy Menu	15-12
Step 3. Verify Drives	15-12
Step 4. Define the Modified Responses (for Modify and Copy Only)	15-15
Step 5. Make Multiple Copies of the From Disk	15-16
What's Next?	15-16
Chapter 16. How to Upgrade Microcode	16-1
Getting Ready to Upgrade Microcode	16-3
An Overview of the Microcode Upgrade Procedure	16-3
How to Determine Maintenance and Microcode Levels	16-4
The Microcode Upgrade Panel	16-5
Microcode Upgrade Procedure	16-6
PF Keys	16-6

Step 1. Select 'Microcode Upgrade' on the Master Menu	16-6
Step 2. Verify Drives	16-7
Step 3. Upgrading the Microcode	16-8
Step 4. Make Multiple Upgrades of Control Disks	16-9
What's Next?	16-9
Chapter 17. How to Initialize the Encrypt/Decrypt Feature	17-1
Getting Ready to Initialize the Encrypt/Decrypt Feature	17-3
An Overview of Encrypting/Decrypting	17-3
Encrypt/Decrypt Procedure	17-5
PF Keys	17-5
Step 1. Select 'Encrypt/Decrypt Master Key' on the Master Menu	17-5
Step 2. Verify Drives	17-6
Step 3. Select an Option	17-7
Option 1: Enter the Master Key Value	17-8
Step 1. Insert the Security Key	17-8
Step 2. Select Option 1 from the Encrypt/Decrypt Utility Panel	17-8
Step 3. Fill In the Panel	17-9
What's Next?	17-10
Option 2: Display the Verification Pattern	17-11
Step 1. Select "Option 2" from the Encrypt/Decrypt Menu	17-11
What's Next?	17-12
Option 3: Verify the Master Key Value	17-13
Step 1. Select Option 3 from the Encrypt/Decrypt Utility Panel	17-13
What's Next?	17-14
Option 4: Test the Encrypt/Decrypt Feature	17-15
Step 1. Insert the Security Key	17-15
Step 2. Select Option 4 from the Encrypt/Decrypt Utility Panel	17-15
What's Next?	17-17
Chapter 18. How to Perform Media Management	18-1
Getting Ready to Perform Media Management	18-3
An Overview of Media Management	18-3
Media Management Options	18-4
PF Keys	18-5
IML Source Selection/Deselection Procedure	18-6
Step 1. Select 'Media Management' on the Master Menu	18-6
Step 2. Select Option	18-6
Step 3. Verify Drives	18-7
Step 4. Select/Deselect the IML Source	18-7
What's Next?	18-8
Subdirectory Deletion Procedure	18-9
Step 1. Select "Media Management" on the Master Menu	18-9
Step 2. Select Option	18-9
Step 3. Verify Drives	18-10
Step 4. Delete Subdirectories	18-10
What's Next?	18-11
Chapter 19. How to Identify Customizing Keyboards	19-1
Getting Ready to Identify the Customizing Keyboard	19-3
When Do You Need to Identify the Customizing Keyboard?	19-3
Identify the Customizing Keyboard Procedure	19-4
PF Keys	19-4
Step 1. Select 'Identify Customizing Keyboard' on the Master Menu	19-4
Step 2. Select the Keyboard Type	19-5

Part 4. Worksheets

Chapter 20. Configuration Worksheets	20-1
Worksheet 1—Host Attachment	20-3
Worksheet 2—BSC	20-4
Worksheet 3—X.25	20-5
Worksheet 4—SDLC	20-6
Worksheet 5—X.21 Switched	20-7
Worksheet 6—Local (Non-SNA)	20-8
Worksheet 7—Local (SNA)	20-9
Worksheet 8—Token-Ring Network	20-10
Worksheet 9—Token-Ring Gateway	20-11
Worksheet 10—Ring Address Assignment	20-12
Worksheet 11—Ring Transmission Definition	20-13
Worksheet 12—117: Port Assignment	20-14
Worksheet 13—128: RTM	20-15
Worksheet 14—X.25 Options	20-16
Worksheet 15—Printer Authorization Matrix (PAM)	20-17
Worksheet 16—3270 Attachment Diagram	20-18
Worksheet 17—ASCII Attachment Diagram	20-19
Worksheet 18—AEA Configure	20-20
Worksheet 19—AEA Port Set	20-21
Worksheet 20—AEA Port to Port Set Map	20-22
Worksheet 21—AEA Station Set	20-23
Worksheet 22—AEA Default Destination	20-24
Worksheet 23—Multiple Logical Terminals	20-25
Worksheet 24—Common SNA	20-26
Non-Katakana Converged Keyboards	20-27
Katakana Converged Keyboards	20-28
Enhanced Keyboard (U.S.)	20-29
Enhanced Keyboard (World Trade)	20-30
Enhanced Keyboard (Katakana)	20-31
Configuration Questions Summary	20-32

Appendixes

Appendix A. Interutility Checking	A-1
An Overview of Interutility Checking	A-3
PF Keys	A-3
Panel Informational Areas	A-4
Correcting Microcode Upgrade Errors	A-5
Correcting Customize Control Disk Errors	A-7
Appendix B. Keyboard and Keypad Layouts	B-1
Alternate Base Keyboard Selection (Question 132)	B-3
Modifiable Keyboards: Standard Layouts (Question 136)	B-5
Modifiable Keypads: Standard Layouts (Question 138)	B-7
Attribute Select Keyboards (Question 166)	B-8

Appendix C. Limited Function Utility Disk	C-1
List of Abbreviations	X-1
Glossary	X-5
Index	X-17

Figures

1-1.	An Example of the 3174 Subsystem Control Unit	1-3
1-2.	An Example of a "Customizing Display Station"	1-6
1-3.	The Master Menu	1-8
1-4.	Customize Control Disk Menu	1-11
1-5.	Standard Panel Layout	1-13
2-1.	The Printer Assignment Indicator	2-4
3-1.	An Example of Calculating the Total MLT Amount	3-19
4-1.	The Port Assignment Panel	4-7
5-1.	Version A of the 128 Panel	5-7
5-2.	Version B of the 128 Panel	5-8
5-3.	Counters and Boundaries	5-9
6-1.	X.25 Options (332 Panel)	6-4
7-1.	Common SNA panel displayed.	7-4
8-1.	The 3270 Response Key	8-8
8-2.	Filling In the Station Type Column on the 3270 Attachment Diagram	8-9
8-3.	Filling In the Default Destination Columns	8-11
8-4.	An Example of 3270 Station Sets	8-12
8-5.	An Example of 3270 Port Sets	8-13
8-6.	ASCII Response Key	8-14
8-7.	Filling In the Station Type Column	8-15
8-8.	Filling In the Default Destination Column on the ASCII Attachment Diagram	8-17
8-9.	Filling In the Port Type Column	8-19
8-10.	Filling In the Modem Type Column	8-21
8-11.	Filling In the AEA Station Set Name Column	8-23
8-12.	An Example of AEA Port Sets	8-25
8-13.	An Example of AEA Station Set Numbering	8-26
8-14.	Example of Port to Port Set Mapping (Assignment)	8-29
8-15.	Example of the AEA Default Destination Worksheet	8-44
10-1.	The Printer Authorization Matrix (PAM)	10-4
10-2.	Example of a PAM Definition	10-7
11-1.	Example of a Blank Keyboard Changes Chart	11-5
11-2.	Keyboard, Shift, and Function Groups — Keyboard Changes Chart	11-6
11-3.	Example of a Completed Keyboard Changes Chart	11-8
11-4.	Deleting Key Functions	11-14
11-5.	Copying from One Key to Another Key	11-15
12-1.	The Master Menu	12-3
12-2.	3174 Models 1L, 1R, 2R, and 3R	12-4
12-3.	3174 Models 51R, 52R, and 53R	12-4
12-4.	3174 Models 81R and 82R	12-5
13-1.	The Master Menu	13-6
13-2.	Disk Drive Assignment Panel	13-6
13-3.	Customize Control Disk Menu	13-8
13-4.	Configure Panel Sequence	13-9
13-5.	Customize Control Disk Menu (select Configure)	13-12
13-6.	Model Attach Panel	13-13
13-7.	Layout of a Typical Host Panel	13-14
13-8.	Token-Ring Gateway Panel	13-15
13-9.	940: Ring Address Assignment Panel (24 lines displayed)	13-16
13-10.	941: Ring Transmission Definition Panel (24 lines displayed)	13-17
13-11.	Common SNA Panel	13-18
13-12.	117: Port Assignment Panel (24 lines displayed)	13-19

13-13.	117 Panel When Responses Are Typed in the #IS Column	13-20
13-14.	117 Panel When Responses Are Typed in the Address Columns	13-20
13-15.	Version A of the 128 Panel	13-21
13-16.	Version B of the 128 Panel	13-22
13-17.	332: X.25 Options Panel	13-23
13-18.	Configure Complete Panel	13-24
13-19.	Customize Control Disk Menu (select Define PAM)	13-28
13-20.	Printer Authorization Matrix Definition Panel	13-29
13-21.	RPQ Utility Panel	13-31
13-22.	RPQ Merge Panel	13-33
13-23.	Customize Control Disk Menu (select Merge RPQs)	13-35
13-24.	RPQ Utility Panel (Merge Procedure)	13-36
13-25.	RPQ Merge Panel	13-38
13-26.	Steps for Defining Keyboard Layouts	13-40
13-27.	Customize Control Disk Menu (select Modify Keyboards)	13-42
13-28.	Modify Keyboard Master Panel	13-43
13-29.	Converged Typewriter Keyboard Panel 1 — Main Part of Keyboard	13-47
13-30.	Converged Typewriter Keyboard Panel 2 — Keys to Right and Left of Main Keyboard	13-47
13-31.	Converged Typewriter Keyboard Panel 3 — Program Function Keys above Main Keyboard	13-48
13-32.	Customize Control Disk Menu (select AEA Configure)	13-58
13-33.	AEA Configure Panel	13-59
13-34.	AEA Port Set Panel	13-60
13-35.	AEA Port to Port Set Map Panel	13-61
13-36.	AEA Station Set Panel	13-62
13-37.	AEA Default Destination Panel (24 lines displayed)	13-64
13-38.	AEA Configure Complete Panel	13-65
13-39.	Customize Control Disk Completion Panel	13-67
14-1.	DSL Merge Panel	14-4
14-2.	DSL Merge Panel for Selecting Drives	14-6
14-3.	The DSL Merge Panel with File Names of Both DSL Disks	14-7
14-4.	Selecting an Option on the DSL Merge Panel	14-8
14-5.	The DSL Merge Panel with the Delete Option	14-9
15-1.	Copy Menu	15-3
15-2.	Available Drives Prompt	15-4
15-3.	Subdirectory Selection	15-5
15-4.	The Maintenance and Microcode Levels	15-6
15-5.	Copy Menu	15-12
15-6.	Available Drives Prompt	15-12
15-7.	Subdirectory Selection	15-14
15-8.	The Modify and Copy Panel	15-15
16-1.	The Maintenance and Microcode Levels	16-4
16-2.	Microcode Upgrade Panel	16-5
16-3.	Microcode Upgrade Panel for Selecting Drives	16-7
17-1.	Encrypt/Decrypt Utility Panel	17-4
17-2.	Encrypt/Decrypt Utility Panel with drive selection	17-6
17-3.	Option 1 — Enter Master Key Value	17-9
17-4.	Verification Pattern	17-10
17-5.	Option 2 — Display Verification Pattern	17-11
17-6.	Option 3 — Verify Master Key Value	17-13
17-7.	Option 4 — Test Encrypt/Decrypt Feature	17-16
18-1.	Media Management Menu	18-4
18-2.	Media Management PF Keys.	18-5
18-3.	Media Management Menu displayed	18-6
18-4.	The Media Management Disk Drive Assignment Panel	18-7

18-5.	IML Source Selection Panel	18-7
18-6.	Media Management Menu	18-9
18-7.	The Media Management Disk Drive Assignment Panel	18-10
18-8.	Subdirectory Deletion Panel	18-10
19-1.	Identify Customizing Keyboard Panel	19-5
A-1.	The Interutility Checking Panel Information Areas	A-4
A-2.	Microcode Upgrade Errors Panel	A-5
A-3.	Customizing Errors Panel	A-7
B-1.	Base Keyboard 8K0808	B-3
B-2.	Base Keyboard 8K0932 (Model C-4)	B-3
B-3.	Base Keyboard 8K1038 (Model C-3)	B-3
B-4.	Base Keyboard 8K1158	B-4
B-5.	Converged Typewriter Layout	B-5
B-6.	Converged Data Entry Layout	B-5
B-7.	Converged APL Layout	B-6
B-8.	Enhanced Typewriter Keyboard Layout	B-6
B-9.	Standard Keypad Layouts	B-7
B-10.	The Attribute Select Typewriter Base Keyboard, Feature 4651 (U.S. English is shown as an example)	B-8
B-11.	The Attribute Select Typewriter/APL Base Keyboard, Feature 4652 (U.S. English is shown as an example)	B-8
B-12.	The Typewriter Overlay Base Keyboard, Feature 4640 (U.S. English is shown as an example)	B-8
C-1.	The Limited Function Utility Master Menu	C-1
C-2.	Limited Function Utility Copy Menu after Option Selection	C-2

Tables

3-1.	Storage Requirements for AEA, MLT, and/or CSCM	3-9
3-2.	Storage Requirements for the Token-Ring 3270 Gateway Feature	3-9
3-3.	Primary and Alternate Configurations for a 3174 Model 1L or 3R with a Type 1, 2, or 3 Teleprocessing Communication Adapter	3-11
3-4.	Conversion of BSC Polling Addresses into Control Unit Addresses	3-13
3-5.	MLT Storage Specification	3-18
3-6.	Keyboard Languages and Character Set I/O Interface Codes Supported	3-21
3-7.	Microcode RPQ Numbers Associated with Keyboards	3-26
3-8.	Host-Channel Attachment Information	3-35
3-9.	Response Selection for Question 317	3-38
3-10.	Response Selection For Question 340	3-40
3-11.	Token-Ring Network Maximum Out	3-45
8-1.	AEA Station-Type-Specific Questions	8-31
8-2.	IBM and Hayes Modem-Embedded Character Substitutions	8-39
8-3.	Micom Modem-Embedded Character Substitutions	8-39
9-1.	Token-Ring Network Maximum Out (Planning for Gateway Feature)	9-6
10-1.	Permitted Printer Assignment Combinations	10-4
11-1.	Keyboard Languages and Character Set I/O Interface Codes Supported	11-17
11-2.	Key Function Nomenclature	11-19
16-1.	Procedures Performed after Microcode Upgrade	16-3

Part 1. Introduction

Chapter 1. For First-Time Users

Chapter 2. Keeping Records

Chapter 1. For First-Time Users

The 3174 Subsystem Control Unit	1-3
What Is Customizing?	1-4
How Do I Plan for Customizing?	1-4
What Microcode Will You Use?	1-5
What Are Microcode Releases?	1-6
How Do You Customize a Control Disk?	1-6
What Is the Master Menu?	1-8
What Is the Customize Control Disk Menu?	1-11
The Customizing Panels	1-13

The 3174 Subsystem Control Unit

The 3174 Subsystem Control Unit (Figure 1-1) is available in both local (channel-attached) and remote (telecommunication-attached) models. It links display stations and printers to the host data processing system; the control unit and the display stations and printers that attach to it are called a *cluster*.

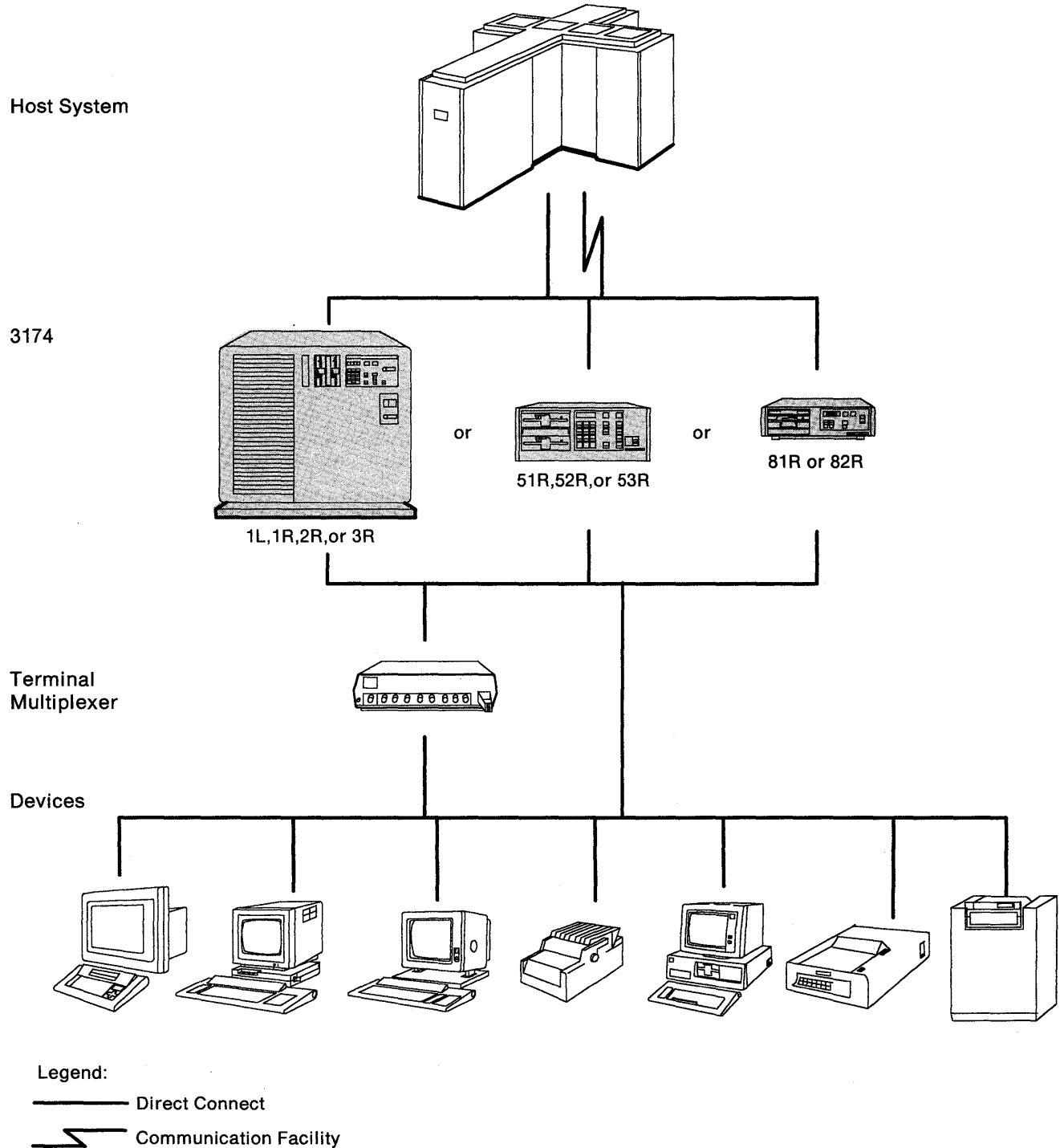

Figure 1-1. An Example of the 3174 Subsystem Control Unit

What Is Customizing?

Customizing consists of tailoring the control unit microcode to support the various types of display stations and printers. Customizing identifies the method(s) and protocol(s) of host attachment that a particular control unit will provide.

Normally, two diskettes arrive with the 3174 Subsystem Control Unit: a Control diskette and a Utility diskette. (The exception to this is when a control unit was ordered using specify code 9005, in which case only a Limited Function Utility diskette accompanies the control unit. See Appendix C for a description of the Limited Function Utility disk.) These diskettes contain the microcode necessary to perform routine diagnostic tests before the control unit goes into operation and then to direct control unit operations. These diskettes can be copied to a fixed disk if they are at a microcode level of A4.0/S4.0 or greater.

During customizing, you tailor the microcode as required for your particular control unit's operations. After the Control disk (diskette or fixed disk) has been customized, you can use it to IML (initial microcode load) the control unit, enabling it to communicate with the display stations, printers, and host.

How Do I Plan for Customizing?

Before you begin to customize a Control disk, you **must** spend time planning. This involves performing the planning procedures and reading the planning chapters in this guide. First, you perform the "Configuration and Reconfiguration Planning Procedure" on page 3-5. Next, you perform the "Storage Planning Procedure" on page 3-7.

When planning your configuration, select your responses to the configuration questions. Then write those responses on the Configuration Worksheets, which are in Chapter 20. The responses you select define the hardware and software configuration in the cluster, the functions the control unit provides, and the method of host attachment. When you are customizing the Control disk, you will type in these responses.

Whenever you customize a Control disk, you will need to perform the Configure procedure. In addition, you may need to perform one or more of these optional customizing procedures:

- Merge DSL
- Copy Files
- Microcode Upgrade
- Encrypt/Decrypt
- Media Management
- Identify Customizing Keyboard
- Define PAM
- Merge RPQ
- Modify Keyboards
- AEA Configure.

These procedures are defined starting on page 1-8.

Because of the reading and decisions involved, planning to customize usually takes longer than the procedure of customizing a Control disk.

What Microcode Will You Use?

Initially operational microcode for the 3174 Subsystem Control Unit is supplied or purchased on a diskette. This microcode can be copied from a diskette onto a fixed disk (with the exception of the Encrypt/Decrypt and RPQ microcode) as separate diskette images. Diskettes and fixed disks are used to load and store the operational microcode and customization data.

Throughout this publication the word “disk” is used as the generic term for the media on which the microcode is stored. A disk may be either a diskette or a fixed disk. There are several different disks that you may use:

3174 Utility Disk: This disk contains the microcode necessary to run various utilities, such as copying disks for a backup. A diskette containing this microcode arrives with the control unit.

3174 Control Disk: Once this disk is customized, it contains the microcode necessary to make the 3174 Subsystem Control Unit operational. This microcode includes, for example, I/O translation tables and keyboard tables, the operational code object modules, diagnostics, and system bringup code. After the Control disk has been customized, it contains the 3174 storage map, cluster parameters, and, if applicable, RPQs, merged with the code. A diskette with this microcode arrives with the control unit.

Note: If you have the IBM Token-Ring Network 3270 Gateway feature, use the 3174 Utility and Control disks at configuration level S; otherwise, use the 3174 Utility and Control disks at configuration level A.

3174 Limited Function Utility Disk: This disk contains the microcode to run Diagnostics, Copy Files, Encrypt/Decrypt Master Key, and Identify Customizing Keyboard. It is used in networks that are under central site control to limit the number of options that can be performed and prevent unauthorized reconfiguration of the controller. A diskette with this microcode arrives with network controllers that are ordered under specify code 9005. (See Appendix C, “Limited Function Utility Disk” for more information.)

RPQ Diskettes: An RPQ (request for price quotation) is an alteration or addition to the functional capabilities the control unit provides. An RPQ diskette is requested by a customer and contains the microcode for up to 30 RPQs. You can choose RPQs from the RPQ diskette to merge onto the Control disk for use during operation. You can also delete RPQs from the Control disk. A maximum of 10 RPQs, or 25K bytes (K equals 1024) of data, will fit on the Control disk. Some installations may choose to use a number of RPQs; others may not use any.

DSL Disks: The DSL (Downstream Load) disk contains the diagnostics, system bringup code, and microcode for a display station that needs the control unit to downstream-load this code to it—for example, the 3290 Information Panel. The DSL disk is also used to load the microcode necessary to support the Asynchronous Emulation Adapter (AEA). You can merge the code from one DSL disk onto another DSL disk. You can have the DSL code for as many as four types of devices, or three types of devices and the AEA, on each DSL disk. If there are no DSL displays in the cluster and you are not configuring for the AEA, you will not need to use a DSL disk.

Encrypt/Decrypt Diskette: The Encrypt/Decrypt diskette is used to install the Encrypt/Decrypt feature, including the master key value, in 3174 Models 1R, 2R, and 3R. This diskette arrives with the feature.

What Are Microcode Releases?

Periodically, IBM makes available upgraded versions of the Utility and Control diskettes that include new functions, such as the ability to handle a new type of display station. Each upgrade is assigned a microcode release level, for example, A4.0. A diskette label identifies the microcode release level. Knowing the microcode level of a diskette may be necessary when you are using some of the customizing procedures, for example, the Copy and Microcode Upgrade procedures. This information is provided on page 16-4.

How Do You Customize a Control Disk?

To customize the Control disk you should be familiar with working at a 3270-type display station. You should also have previously prepared configuration worksheets (see Chapter 3, "Planning to Configure").

Chapter 12, "How to Display the Master Menu" illustrates how to turn on the control unit, perform the Alt 1 IML procedure, and display the Master Menu.

To customize the control unit, you must load the **Utility** microcode by issuing an Alt 1 IML to the control unit. The microcode can be loaded from either a diskette or fixed disk. If the control unit is to be IMLed from the fixed disk, you must first set up the fixed disk by performing the required procedures in Chapter 15, "How to Copy Files" and Chapter 18, "How to Perform Media Management."

When you have turned on the control unit and performed the Alt 1 IML procedure, you customize at a "customizing display station" attached to port 26-00 of the control unit (see Figure 1-2).

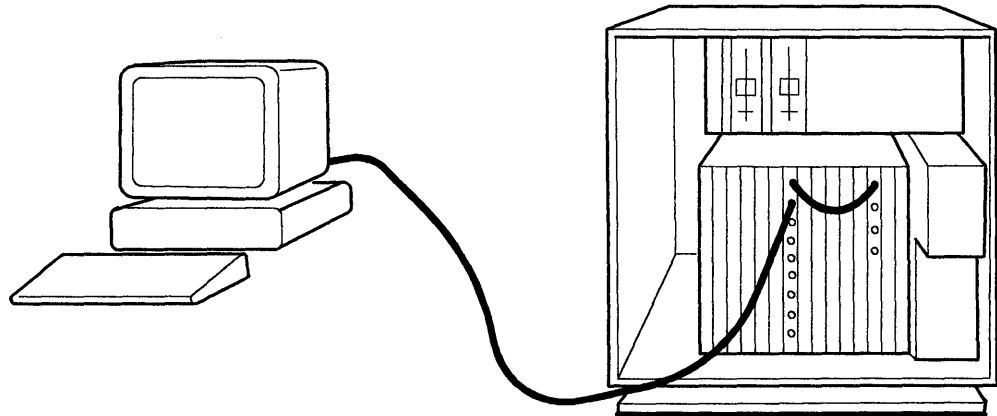

Figure 1-2. An Example of a "Customizing Display Station"

As you work, a series of menu panels appearing on the screen ask you a number of questions. You type in responses to those questions from the Configuration Worksheets. These responses are written onto the Control disk. In Part 3 of this manual, the customizing procedures are described in detail. After a Control disk has been customized, you can reconfigure it if you change the hardware or software configuration. The "Planning" and "How to" chapters have the information you need for reconfiguring the disk.

Only the following display stations can be used as customizing display stations:

- 3178
- 3179 Model 1 operating in native or 3279-emulation mode
- 3180 operating in native or 3278-emulation mode
- 3191
- 3192
- 3194 operating in control unit terminal (CUT) mode
- 3270 Personal Computer with 3278/3279 emulation, operating in CUT mode
- 3278 (except Model 1)
- 3279
- 5550 family operating in CUT mode
- 5578 operating in CUT mode
- 6150 RT Personal Computer
- 6151 RT Personal Computer.

What Is the Master Menu?

The Master Menu (Figure 1-3) is the first panel displayed when you IML (initial microcode load) the control unit to customize the Control disk. (See Chapter 12 for the IML procedure.) From this menu, you select the customizing procedures you want to follow, one at a time. You will not need to select all of the customizing procedures each time you customize a Control disk. For simple clusters, you may need to select only two or three. After you look at the Master Menu, read the definitions of the procedures.

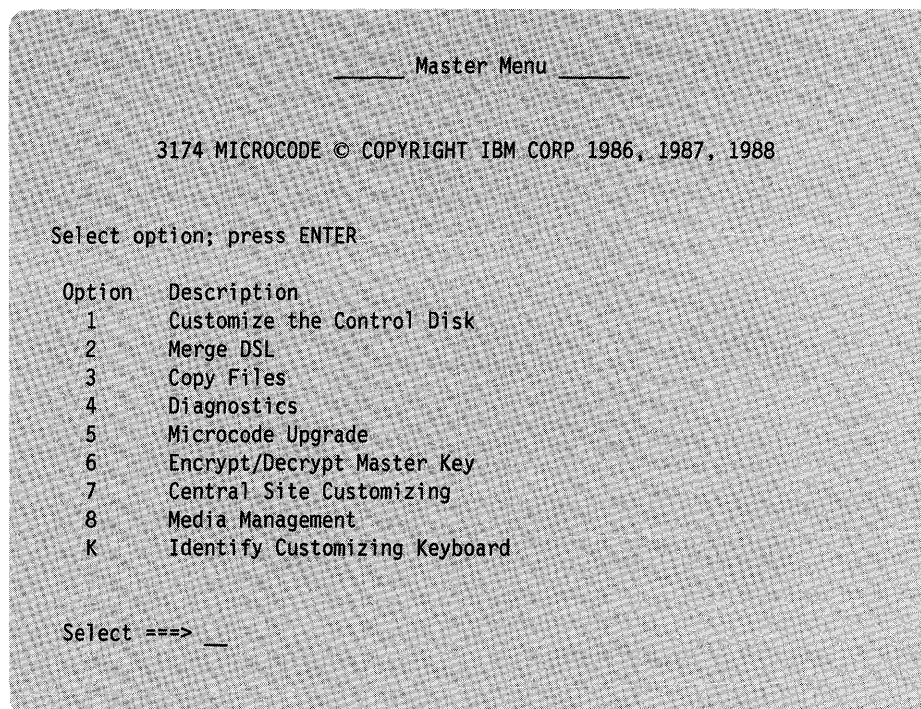

Figure 1-3. The Master Menu

Option 1 - Customize the Control Disk

Some customizing requires that hardware and software configuration information be either specified or modified on the Control disk that will be used to make a 3174 operational; for example, defining host, device, and printer attachments, modifiable-keyboard types, and RPQs. When you select this procedure, a second menu is displayed. See Figure 1-4 on page 1-11, and see Chapter 13 for the procedure.

Option 2 - Merge DSL Code

For DSL displays or for the AEA (both of which require the control unit to downstream-load microcode), there is a separate DSL disk. During this procedure, you merge one DSL disk onto another DSL disk. See Chapter 14, "How to Merge DSL Code" for this procedure.

Option 3 - Copy Files

This selection allows you to duplicate valid 3174 disks. For example, Control, DSL, and Utility disks, and copy portions of a Control disk or to modify certain parameters during a copy. See Chapter 15, "How to Copy Files" for this procedure.

Option 4 - Diagnostics

IBM service representatives or customer service personnel can select this procedure to detect and isolate hardware or software problems in the control unit.

Option 5 - Microcode Upgrade

When new function or maintenance enhancements are added to a configuration support, IBM sends its customers, at their request, an upgraded Utility, Control, RPQ, or DSL diskette. During this procedure, you merge the customization data from an already customized Control disk onto the upgraded Control disk. See Chapter 16, "How to Upgrade Microcode" for this procedure.

Option 6 - Encrypt/Decrypt

If you have ordered the Encrypt/Decrypt feature for your 3174, you need to use this procedure. The Encrypting/Decrypting procedure protects data from unauthorized disclosure by encrypting data sent from the 3174 to the host system and by decrypting data received by the 3174 from the host system. Only authorized persons should use this procedure. For this procedure, see Chapter 17, "How to Initialize the Encrypt/Decrypt Feature."

Option 7 - Central Site Customizing

Central Site Customizing allows you to tailor control unit microcode for each control unit in a network at a central location. The tailored microcode can then be sent electronically (if you are using the NetView™ Distribution Manager software package) or physically (on a diskette) to the various control units in the network, while a copy of the customization is stored at the central site for future reference. See the *Central Site Customizing User's Guide*, GA23-0342, for more information.

Option 8 - Media Management

If your 3174 Subsystem Control Unit is equipped with at least one fixed disk drive, you may wish to perform this procedure. The Media Management procedure provides a means for managing the data resident on a fixed disk. You may use this procedure to set up a fixed disk in order to IML from it, or you can use this procedure to delete subdirectories that are stored on it. Chapter 18, "How to Perform Media Management" describes the procedure.

Option K - Identify Customizing Keyboard

During this procedure, you identify on a Utility disk the keyboard of the display you are using to customize. The keyboard you specify will be supported on that disk for *all* other customizing procedures *and* any time you recustomize using that disk. Select this procedure if you do not know what keyboard type was used during previous customizing or if you want to change the keyboard type.

If you do not select this procedure the first time a disk is used, you will get the default. The default is a QWERTY¹ layout in one of these keyboards: Typewriter, Data Entry, APL (with APL off), or Text (with Text off). (See Appendix B, "Keyboard and Keypad Layouts" for examples of these QWERTY keyboard layouts.)

If the keyboard is in one of the following languages, you *must* select the Identify Customizing Keyboard procedure the first time that a disk is customized:

- Austrian/German
- Belgian
- French, AZERTY layout
- Italian
- Japanese English
- Japanese Katakana.

If you need to select the Identify Customizing Keyboard procedure, select it before any other customizing procedure.

See Chapter 19, "How to Identify Customizing Keyboards" for the procedure.

¹ "QWERTY" keyboards get their name from the first six characters on the top row of alphabetic keys: Q-W-E-R-T-Y. Other types of keyboards get their names in a similar way. On AZERTY keyboards, for instance, the first six characters are A-Z-E-R-T-Y.

What Is the Customize Control Disk Menu?

If you select option 1 from the Master Menu, the Customize Control Disk Menu (Figure 1-4) is displayed and allows you to select from five other procedures. After you look at the Customize Control Disk Menu, read the procedure definitions.

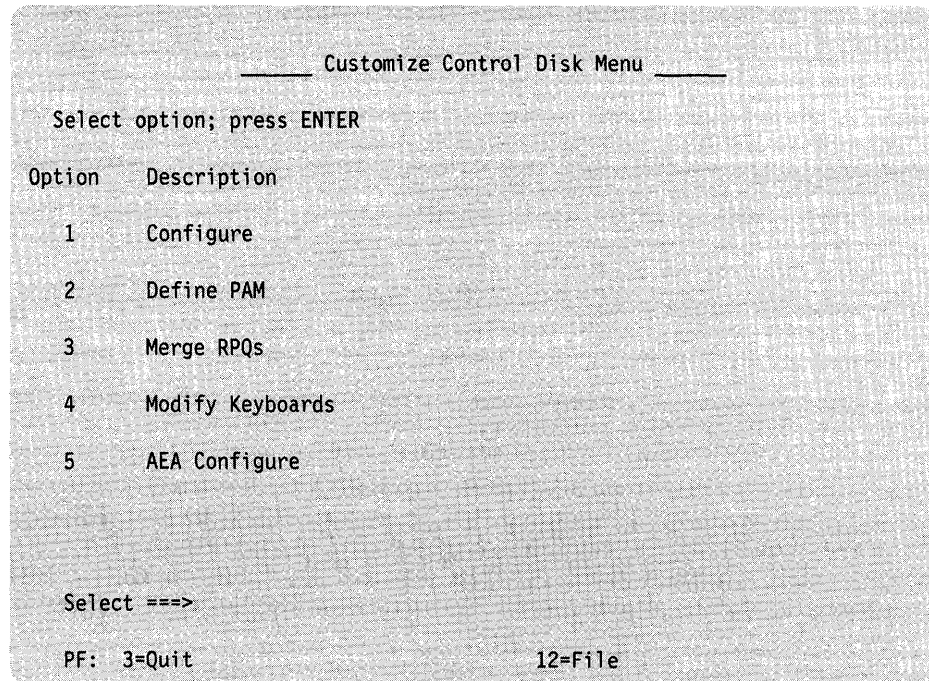

Figure 1-4. Customize Control Disk Menu

Option 1 - Configure

During this procedure, you type in responses to the numbered questions that describe the configuration of hardware and software. This is the one customizing procedure that *must* be selected whenever you initially customize a Control disk. You also select this procedure when you want to “reconfigure,” or modify some of the responses you entered when you first followed the Configure procedure. Chapter 3, “Planning to Configure” contains the planning information you need to read before configuring or reconfiguring. Chapter 13, “How to Customize the Control Disk” describes the procedure for configuring and reconfiguring.

Option 2 - Define PAM

On the Printer Authorization Matrix (PAM) panel, you define which displays may use which printers for local copy, host copy, or shared copy operations. Select this procedure to define a PAM initially or to change an existing one. Chapter 10, “Planning to Define the Printer Authorization Matrix (PAM)” contains the necessary planning information and Chapter 13, “How to Customize the Control Disk” provides instructions for the procedure.

Option 3 - Merge RPQs

During this procedure, you can select RPQs to be included in the operational IML. This procedure also allows you to delete RPQs. For this procedure, see Chapter 13, "How to Customize the Control Disk."

Option 4 - Modify Keyboards

Some display stations have modifiable keyboards that allow you to create keyboard layouts for specific user applications. During this procedure, you define the unique keyboard layouts for these modifiable keyboards. Chapter 11, "Planning to Modify Keyboards" contains the planning information and Chapter 13, "How to Customize the Control Disk" describes the procedure for modifying keyboards.

Option 5 - AEA Configure

During this procedure, you enter responses in the input fields of several panels, as well as responding to questions that describe the configuration of hardware and software for both 3270 and ASCII devices. This procedure *must* be selected when you initially customize a Control disk for ASCII devices, but should be performed after the regular configure procedure. You also select this procedure when you want to reconfigure or to modify some of the responses you entered when you first followed the AEA Configure procedure. Chapter 8, "Planning for the Asynchronous Emulation Adapter" contains the planning information you need to read before configuring for the AEA or reconfiguring for it. Chapter 4, "Planning for Port Assignment" and Chapter 10, "Planning to Define the Printer Authorization Matrix (PAM)" provide information on Port Assignment and PAM requirements that must be considered when configuring for the AEA.

The Customizing Panels

After you select a customizing procedure from the Master Menu, various panels for that procedure will appear on the screen of your display station. The panels guide you through the procedure. Though each panel is unique, they all share a common design. The standard panel layout is illustrated in Figure 1-5, although all the features illustrated here do not appear on every panel. For example, not all panels display PF keys.

Note: The size of the screen you are using will determine how much information you will see. For example, a 3278 Model 2 will show only 24 lines of information, while a 3278 Model 4 will display 43 lines of information.

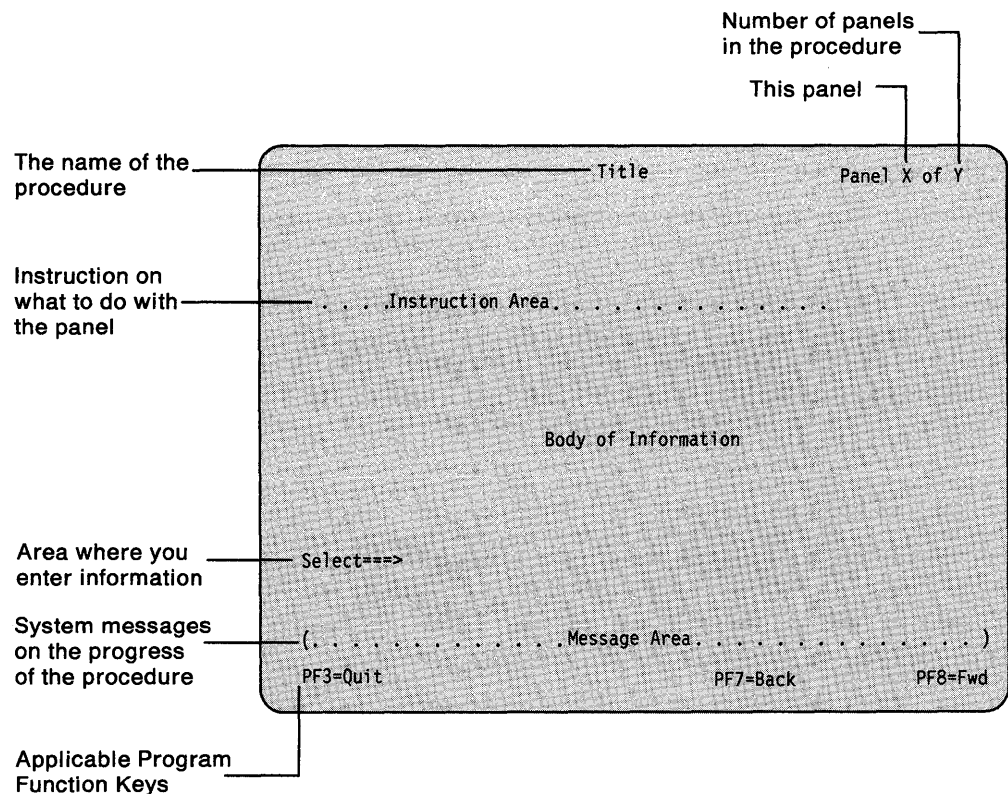

Figure 1-5. Standard Panel Layout

Chapter 2. Keeping Records

- Methods of Record-Keeping 2-3
 - Local Copy 2-3
 - Planning Worksheets 2-5
 - Duplicate Diskettes 2-5
 - Using the Copy Procedure to Manage Customization Data 2-6

Methods of Record-Keeping

There are several methods of record-keeping, including duplicating disks, making local copies of the customizing panels, and making copies of the customizing worksheets. Setting up a record-keeping system now can save you time later. If you do the customizing for dozens—or hundreds—of control units, it is recommended that you keep several records of the control unit customizations, including using the Central Site Customizing procedure. The *Central Site Customizing User's Guide*, GA23-0342, describes that procedure. This chapter explains other 3174 functions designed to assist you with record-keeping.

When there is a problem with the control unit, the control unit operator or IBM service personnel look in the control unit for a record of the customization. You can store a set of your local copy customization records in your control unit. In Models 1L, 1R, 2R, and 3R, there is a pocket in the control unit door where you can store the records. On the face of Models 51R, 52R, and 53R, there is a disk drive on the top left side and a drawer beneath it. Store your customization records in the drawer. For Models 81R and 82R, store your customization records near the control unit.

Local Copy

The local copy function is an easy-to-use tool for keeping records. You can print a copy of each customization panel on your display screen as soon as you have entered your responses and verified them. Then you can organize a set of these customization records in control unit serial number order and keep them together in a binder or in a file drawer.

Note: Only non-ASCII printers can be used for the local copy at customization time.

Step 1. Turn On the Printer

You can turn on the printer that you plan to use for local copy either before or after you turn on the control unit. For local copy, a default Printer Authorization Matrix (PAM) is in operation and authorizes all printer ports for all displays. Therefore, the first authorized available printer you turn on before or during a customization session can be used for local copies, but only during that session. This printer may be attached to any port other than 26-00.

On the screen of the customizing display station, the printer assignment indicator (Figure 2-1 on page 2-4) appears in the lower right corner of the screen; *nn* is the printer authorized for the local copy. When *nn* is 70, the default PAM selects the printer. You can specify a different printer by using the Print Ident key. (See the documentation that describes the display station you are using to find the Print Ident Key.) The local copy will go to the printer at the port with the lowest number.

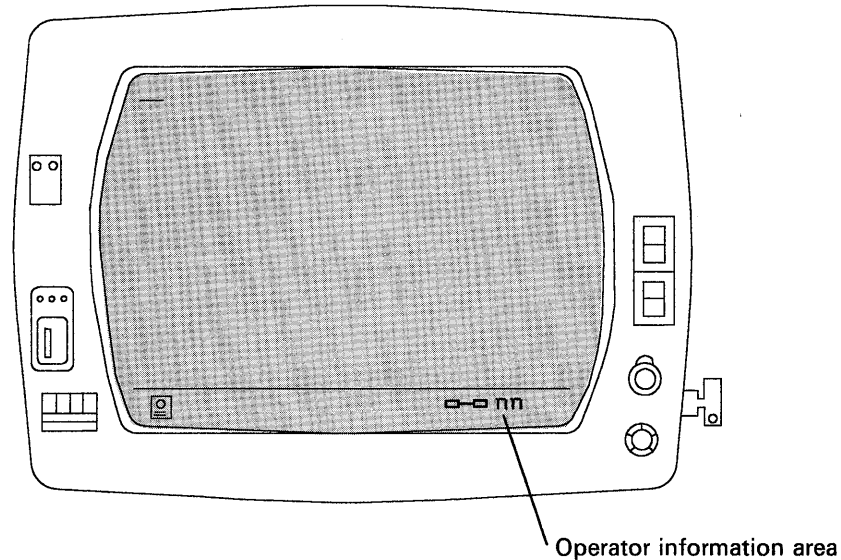

Figure 2-1. The Printer Assignment Indicator

Step 2. Request a Local Copy

After you complete a customization panel:

1. Press ENTER to verify your responses.
2. Press the Print key to make a copy of the customization panel currently displayed.

If you request a second copy while the printer is still busy with your first request, the second copy will be queued. If a third copy request is made while the printer is still busy with the first, the Operator Retry indicator will be displayed in the operator information area. You will have to wait and then retry the third local copy request.

If you want to stop a customizing local copy after it has been queued, press the Device Cancel key. (See the documentation that describes the display station you are using for this key.)

Step 3. Attach labels to the Printed Copies

Attach labels to the printed copies of the customization panels giving the:

- Serial number of the control unit. If you use the control unit serial number as your response to configuration question 108 (Unique Machine Identifier), you already have a printed record of the serial number.
- Location of the control unit.
- Date of the customization.
- Microcode release level.

Planning Worksheets

Two types of worksheets are provided to help plan and record customizing information.

- Configuration Worksheets

Blank copies of these worksheets are located in Chapter 20. You are authorized to make as many copies as you need.

The customizing planner records responses to the configuration questions on these worksheets. The customizer in turn uses the completed worksheets to fill in the customization panels. If you do not plan to use the local copy function, you can keep records by photocopying the completed worksheets. You can organize these customization records in order according to their control unit serial numbers and keep them together in a binder or in a file drawer.

On the configuration worksheets, the only questions presented are those that apply to the specific configuration you are planning or customizing for. The questions are arranged on the configuration worksheets so that they match the panels displayed on your screen.

- Configuration Questions Summary

This worksheet is located at the end of Chapter 20. It lists the configuration questions in numeric order, with the name of each question and a space for your response. The panels that do not contain configuration questions are on separate worksheets.

The Summary is provided for those who prefer having the configuration question responses organized in numeric order, along with the names of the questions.

Use either the Configuration Questions Summary or the applicable configuration worksheets. **Do not use both**, because they contain the same questions, arranged differently.

Duplicate Diskettes

Making a duplicate of each Utility and Control disk is highly recommended. The duplicate disk can be used as a backup for the original disk.

To make a duplicate Utility or Control disk, use the Full Copy or Copy Customizing Data option. The planning and procedural information for these copy options is in Chapter 15, "How to Copy Files."

You should identify any diskette(s) that you duplicate. Affix a label to the upper portion of the diskette. The label identifies the diskette type by name. In addition, you may wish to write a unique designation of your own on the label. For example, you could specifically identify the configuration and 3174 Subsystem Control Unit in which the diskette is to be customized and used. You can order the *IBM 3174 Diskette Identification Labels*, GX23-0389, to record this information.

Using the Copy Procedure to Manage Customization Data

You can manage your customization data and/or microcode in several ways: by the suggested method of electronic distribution (requires the NetView DM software package), by using the Central Site Change Utility (see the *Central Site Customizing User's Guide*, GA23-0342, for more information), or by using the Copy procedure and mailing the diskettes. If you use the copy procedure, the 3174 Control Unit used at the central site will require two disk drives.

If you distribute your customization data on diskettes, there are several situations when you will be concerned with the management of the diskettes in your network. Among these are:

- When control units are initially installed.
You will need to provide a customized Control diskette to each of the control units in your network. This requires performing procedures described in Chapter 13, "How to Customize the Control Disk."
- When microcode update diskettes are received.
You will need to perform the procedure in Chapter 16, "How to Upgrade Microcode." If you want to provide new enhancements as well, you will also need to perform procedures described in Chapter 13, "How to Customize the Control Disk."
- When changes are made to existing configurations.
You will need to perform the Reconfigure procedure in Chapter 13, "How to Customize the Control Disk."

The following method is suggested if you have one or more of the above situations and wish to use the copy procedure to manage customization data.

1. Prepare a master diskette at the central site. If possible, test the master diskette by performing an IML on it and running a 3174 with it before making copies. Be sure to resolve all problems before making copies.
2. Use the Copy function to make copies for the other 3174 control units in your network.

Complete and attach a diskette identification label (GX23-0389 or equivalent) to each copy. You should also complete the 3174 Configuration Questions Summary, located in Chapter 20. Keep the original for your records, and send a copy with the diskette.
3. Use a reusable shipping container to send the customized diskettes to the control unit for which they were made. You will probably want to enclose a note to the location personnel telling them to insert the diskette, close the diskette drive, and perform an IML on their control unit. Also instruct them to return the reusable shipping container, with the old diskettes, to the central site machine location.
4. Maintain a record of the diskettes in your network to show the diskette type and release level, and the date that the diskette was installed.

For additional information on the Copy Files procedures, see Chapter 15, "How to Copy Files."

Part 2. Planning

Chapter 3. Planning to Configure

Chapter 4. Planning for Port Assignment

Chapter 5. Planning for Response Time Monitor (RTM)

Chapter 6. Planning for X.25

Chapter 7. Planning for Central Site Change Management (CSCM)

Chapter 8. Planning for the Asynchronous Emulation Adapter (AEA)

Chapter 9. Planning for the Token-Ring Network 3270 Gateway

Chapter 10. Planning to Define the Printer Authorization Matrix (PAM)

Chapter 11. Planning to Modify Keyboards

Chapter 3. Planning to Configure

Getting Ready to Plan to Configure	3-3
Why Do You Need to Plan?	3-3
How Do You Plan?	3-3
Display Compatibility Requirements	3-4
Can You Use a Pattern Control Diskette?	3-4
Configuration and Reconfiguration Planning Procedure	3-5
Storage Planning Procedure	3-7
Configuration Questions	3-10
099: Product Assistance Data	3-10
100: 3174 Model Designation	3-10
101: Host Attachment	3-11
104: Control Unit Address	3-12
105: Upper Limit Address	3-14
106: Token-Ring Network Address of the 3174	3-15
107: Token-Ring Network Address of the Gateway	3-16
108: Unique Machine Identifier	3-16
110: Multiple Logical Terminals (MLTs) Configuration Level	3-17
116: Individual Port Assignment	3-20
117: Port Assignment	3-20
118: Port Address	3-20
121: Keyboard Language and Character Set I/O Interface Code	3-20
123: Country Extended Code Page Support	3-22
125: Miscellaneous Feature Options	3-22
127: Response Time Monitor (RTM) Definition	3-24
128: RTM Boundaries and Interface Specification	3-25
132: Alternate Base Keyboard Selection	3-25
136: Modifiable Keyboards: Standard Layouts	3-26
137: Modifiable Keyboard: Modified Layouts	3-27
138: Modifiable Keypad: Standard Layouts	3-28
141: Magnetic Character Set	3-28
165: Compressed Program Symbols	3-29
166: Attribute Select Keyboard	3-29
168: Additional Extension-Mode Key Definition (Personal Computers)	3-29
173: Distributed Function Terminal (DFT) Options	3-30
175: Distributed Function Terminal (DFT) Password	3-32
176: BSC Enhanced Communication Option: Distributed Function Terminals	3-32
178: 7232 Dual Control Unit Terminal Multiplexer Switching	3-33
213: Between Bracket Printer Sharing	3-33
215: Physical Unit Identification	3-33
220: Alert Function	3-34
222: Support of Command Retry	3-34
223: Attention Delay Value	3-36
224: Mode of Data Transfer	3-36
225: Channel Burst Size	3-36
310: Connect-Data-Set-to-Line (CDSTL) Operation	3-37
313: NRZ or NRZI Encoding	3-37
317: Telecommunication Facilities	3-38
318: Full- or Half-Speed Transmission	3-39
332: X.25 Options	3-39
340: RTS Control Response Options	3-39
360: X.21 Switched Retry (Models 2R, 52R, and 82R Only)	3-40

361: X.21 Switched Retry Timing (Models 2R, 52R, and 82R)	3-40
362: X.21 Switched Options	3-41
365: X.21 Data Transfer Delay (Models 2R, 52R, 82R)	3-42
367: X.21 Switched Short-Hold Mode	3-43
368: X.21 Switched Short-Hold Mode Dial Number	3-43
370: Maximum Inbound I-Frame Size	3-43
380: Maximum Receive I-Frame Size	3-44
381: Token-Ring Network Maximum In	3-44
382: Maximum Transmission I-Frame Size	3-45
383: Token-Ring Network Maximum Out	3-45
Planning to Reconfigure	3-46
Host Panel	3-46
117: Port Assignment Panel	3-46
128: RTM Panel	3-46
332: X.25 Options Panel	3-46
What's Next?	3-46

Getting Ready to Plan to Configure

Before you start, you need the following:

- The configuration worksheets in Chapter 20. These worksheets help to determine which configuration questions you should answer.
- Completed site planning worksheets.
- Information about the display stations and printers you want to attach to the 3174.
- Information from your system programmer about responses to some of the configuration questions.
- Information on the amount of storage installed in the control unit you are customizing.

Why Do You Need to Plan?

When you select “Configure” from the Customize Control Disk Menu, a series of panels are displayed, each of which is filled with numbers representing configuration questions. You type in your responses to these questions by referring to your already prepared Configuration Worksheets. These worksheets are prepared during the *planning* process, which this chapter will help you perform.

If you have not carefully planned your configuration and filled out the worksheets, the function(s) you want may not operate properly. In addition, the control unit must be customized in the offline mode; having to make decisions about customizing at this time could cause the control unit to be unavailable for a longer period of time.

When you reconfigure, you need to plan also. Reconfiguring means modifying some of the responses that you entered when you initially configured the Control disk. The planning information for reconfiguring is on page 3-46. The procedure used for configuring and reconfiguring is described in Chapter 13, “How to Customize the Control Disk.”

How Do You Plan?

Planning is a two-part process. The first part of the process involves planning your configuration by following the “Configuration and Reconfiguration Planning Procedure” on page 3-5. You can also use the “3174 Quick-Reference Guide for Planners” as a guide for planning your configuration. If you have some familiarity with the configuring process, the flowchart in Figure 13-4 on page 13-9 provides a visual summary of the panels you may need to complete on the configuration worksheets and the “Quick Reference to 3174 Configuration Questions” can be used to select your responses to the configuration questions.

The second part of the planning process involves performing the “Storage Planning Procedure” on page 3-7 to ensure that your control unit contains sufficient storage to support the functions you have planned to configure. Planning for storage is an important part of the planning process. If insufficient storage is available for the function(s) you have planned to configure, the function(s) may not work.

Display Compatibility Requirements

3290 Compatibility with the Host: If any 3290 Information Panels are in the cluster, setup level 3 changes may be required to make the 3290 logical terminals compatible with their definition at the host, so that the host can communicate with them. Check with the system programmer. If setup level 3 changes are required, after customizing is completed, you need to IML (initial microcode load) the Control disk and then set the control unit offline before switching on the 3290 and going into setup level 3. DSL (downstream load) code is also required to make the 3290 operational. For more information, see the *IBM 3290 Information Panel Description and Reference*, GA23-0021.

Customization Compatibility between the IBM 3270 Personal Computer and the 3174 Subsystem Control Unit: If any 3270 Personal Computers are in the cluster, obtain a copy of the Information Worksheet used for customizing the IBM 3270 Personal Computer system diskette. The information on this worksheet should agree with the responses to the 3174 configuration questions. For more information, see the *IBM 3270 Personal Computer Introduction and Preinstallation Planning*, GA23-0179.

Can You Use a Pattern Control Diskette?

To speed up customizing, some customizers create "pattern" Control diskettes. A pattern Control diskette is a diskette that contains a standard hardware and software configuration used for more than one cluster. Once you create a pattern diskette, you can make copies by selecting the Copy procedure from the Master Menu.

For example, one pattern diskette could apply to clusters that have the following configuration:

- 3174 Model 1R
- Local SNA host attachment
- No distributed function terminals (DFTs)
- No port assignment table
- No Printer Authorization Matrix (PAM)
- Control microcode at the current microcode release level.

Another pattern diskette could be made for clusters that have this configuration:

- 3174 Model 1L
- Local non-SNA host attachment
- Display stations with modifiable keyboards
- A port assignment table
- A PAM with printers used for local copy assigned to ports 01, 02, and 03
- Control microcode at the current microcode release level.

Configuration and Reconfiguration Planning Procedure

The configuration questions in this chapter cover all 3174 model types and host attachments. The configuration questions are numbered (099, 100, 101, and so on). The Configuration Worksheets in Chapter 20 represent the panels displayed during the Configure procedure, and Figure 13-4 on page 13-9 shows the panels that may appear. The numbers on the worksheets and panels represent the configuration questions.

In question 101 on "Worksheet 1—Host Attachment," you select the method of host attachment (for example, BSC or SDLC). Read and answer only the questions shown on the worksheet; these questions will be displayed on the panel. Where to find the planning information, a list of the question numbers, and a short description of each question can be found on each worksheet.

Select your responses, and write them in the boxes. Some questions have a default response printed under the box. To tell the customizer the default is to be used, circle it and leave the box blank. (The microcode automatically supplies the default unless you specify a different choice.)

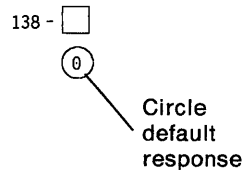

Planner: Use the following procedure to plan your configuration. During this procedure, you will be leaving these steps and going to the planning sections of this publication that contain the information needed to fill out the worksheets. Once the worksheet(s) that are required for a step are completed, you will be returning to this procedure to complete the next step.

Step 1: Fill out "Worksheet 1—Host Attachment" on page 20-3. The information you need to fill out this worksheet starts on page 3-10.

Step 2: On Worksheet 1 you specified a response to question 101. Depending on your response to question 101, fill out one of the following host worksheets:

If Question 101-Host Attachment	Fill out Worksheet
= 1 - BSC	2
= 2 - SDLC and/or X.21 Nonswitched (with or without the 3270 Gateway feature)	4
= 3 - X.25	3
= 4 - Local Non-SNA	6
= 5 - Local SNA (with or without the 3270 Gateway feature)	7
= 6 - X.21 Switched	5
= 7 - Token-Ring Network	8

The information you need to fill out these worksheets starts on page 3-12.

Note: If you are filling out worksheet 2 or 6, proceed to step 4 on page 3-6 after completing the worksheet.

Planning to Configure

Step 3: The worksheet you filled out in step 2 determines the next worksheet(s) that must be filled out. Use the following table to determine the worksheet(s) you need to fill out next.

If You Filled Out Worksheet	Fill Out Worksheet(s)	If 3270 Gateway feature Fill Out Worksheet(s)
3	14, 24	
4	24	9, 10, 11, 24
5	24	
7	24	9, 10, 11, 24
8	24	

Step 4: Depending on your responses to certain configuration questions on the worksheet you filled out in step 2, you may need to fill out one or more of the worksheets in the following table. If not, go to step 5.

If, on Worksheet(s)	Question	Fill Out Worksheet
2 through 8	116 = 1 or 2	12
2 through 8	127 = nonzero	13

Step 5: If you wish to configure for one of the following features, fill out the worksheets indicated.

Wish to Configure for	Fill out Worksheet(s)
Asynchronous Emulation Adapter	16 through 22
Printer Authorization Matrix	15
Modified Keyboards	Keyboard 1—5

After you have completed all the worksheets required for your configuration, complete the second part of the planning process by performing the "Storage Planning Procedure" on page 3-7. If you have already ensured that your control unit contains sufficient storage to support the function(s) that you planned for, give the completed worksheets and this manual to the person who will customize the Control disk. How to enter this configuration information on the disk is explained in Chapter 13, "How to Customize the Control Disk."

Storage Planning Procedure

You need to plan for control unit storage if you planned for the Token-Ring 3270 Gateway feature, Multiple Logical Terminals (MLT), Central Site Change Management (CSCM), and/or the Asynchronous Emulation Adapter (AEA) while performing the steps in the "Configuration and Reconfiguration Planning Procedure." If sufficient storage is not installed in the control unit, some support for the function(s) you planned will be deconfigured (function will not operate or will operate at a lower level) once the control unit has been customized and IMLed. When functional support has been deconfigured, a unique status code appears in the operator's panel, an error log is written to the disk, and the IML continues. For information on viewing the error logs, see the *Customer Extended Problem Determination* manual, GA23-0217. The *3174 Status Codes* manual, GA27-3832, contains the information on the status code meanings.

Planner: Use the following steps and the worksheets you completed during the "Configuration and Reconfiguration Planning Procedure" to plan your control unit's storage.

Step 1: Refer to the table(s) containing the storage requirements for the function(s) you wish to configure.

If you will be configuring:	On page 3-9, refer to:
AEA, CSCM, and/or MLT	Table 3-1
The Token-Ring 3270 Gateway feature	Table 3-2

Note: If you are configuring for the Token-Ring 3270 Gateway feature, you will need to add either Base or functional storage requirements from Table 3-1 to the storage requirements from Table 3-2.

Step 2: Perform this step while looking at the table(s) you were sent to in step 1. Across the top of the table, locate the first function or level of the first function you want to configure. Next, down the left side of the table, locate the level of the second function you want to configure. Then, read across the table to determine the storage requirements for your control unit's configuration (all values are in megabytes [MB]). Examples 1 and 2 on page 3-8 illustrate how to determine storage requirements.

Example 1

Assume you want to configure AEA and CSCM-1 (see the legend on page 3-9). Step 1 directs you to Table 3-1. As shown below, find CSCM-1 across the top and AEA down the left side. The storage required is 1.5 megabytes.

	Base	CSCM-0	CSCM-1	CSCM-2
Base	1.0	1.0	1.5	1.5
AEA	1.0	1.5	1.5	1.5
MLT-1	1.0	1.0	1.5	2.0

If you are configuring for the 3270 Gateway feature only, you will need to add the Base storage requirements from Table 3-1 on page 3-9 to the storage you will require for the 3270 Gateway feature. If you are configuring for the 3270 Gateway feature in addition to one or more other functions, add the storage required for the other function(s) to the storage required for the 3270 Gateway feature (do not add in the Base requirements; see Example 2).

Example 2

You want to configure for CSCM-0, MLT-1, and the Token-Ring 3270 Gateway feature on a Remote Model (RGATE) with 72 DSPUs.

1. You would find the storage required for CSCM-0 and MLT-1 (1.0MB).

	Base	CSCM-0	CSCM-1	CSCM-2
Base	1.0	1.0	1.5	1.5
AEA	1.0	1.5	1.5	1.5
MLT-1	1.0	1.0	1.5	2.0

2. Find the storage required in Table 3-2 (shown below).

	28 DSPUs	72 DSPUs	116 DSPUs	140 DSPUs
LGATE	0.5	1.0	1.5	2.0
RGATE	0.5	0.5	1.0	1.0

The storage requirements for an RGATE with 72 DSPUs is 0.5MB. Add the storage required for CSCM-0 and MLT-1 to the storage required for an RGATE with 72 DSPUs (1.0MB + 0.5MB = 1.5MB).

Step 3: Ensure that your control unit contains sufficient storage by comparing the storage requirements for the functions you want configured with the storage installed in the control unit. If the storage installed in the control unit is less than the storage required for the function(s) you want, you will need to add storage or leave some function unconfigured.

After you have finished planning for storage, give the completed worksheets and this manual to the person who will customize the Control disk. How to enter this configuration information on the disk is explained in Chapter 13, "How to Customize the Control Disk."

The values shown in the following tables are in megabytes.

Table 3-1. Storage Requirements for AEA, MLT, and/or CSCM				
	Base	CSCM-0	CSCM-1	CSCM-2
Base	1.0	1.0	1.5	1.5
AEA	1.0	1.5	1.5	1.5
MLT-1	1.0	1.0	1.5	2.0
MLT-1, AEA	1.0	1.5	1.5	2.0
MLT-2	1.0	1.5	1.5	2.0
MLT-2, AEA	1.5	1.5	1.5	2.0
MLT-3	1.5	1.5	2.0	2.0
MLT-3, AEA	1.5	2.0	2.0	2.0
MLT-4	2.0	2.0	2.5	2.5
MLT-4, AEA	2.0	2.5	2.5	3.0
MLT-5	2.5	2.5	3.0	3.0
MLT-5, AEA	2.5	3.0	3.0	—

Table 3-2. Storage Requirements for the Token-Ring 3270 Gateway Feature				
	28 DSPUs	72 DSPUs	116 DSPUs	140 DSPUs
LGATE*	0.5	1	1.5	2
RGATE*	0.5	0.5	1	1

*When configuring for the 3270 Gateway feature only, add the Base storage requirements from Table 3-1 to the values from Table 3-2 to obtain the total storage required.

Legend

- AEA Asynchronous Emulation Adapter
- MLT 1–5 MLT levels
- CSCM-0 CSCM for a Central Site Control Unit with diskette drives only or a Network Site Control Unit with up to two fixed disk drives
- CSCM-1 CSCM for a Central Site Control Unit with up to one fixed disk drive
- CSCM-2 CSCM for a Central Site Control Unit with up to two fixed disk drives
- LGATE Local Models with the 3270 Gateway feature
- RGATE Remote Models with the 3270 Gateway feature
- DSPUs Downstream Physical Units

Configuration Questions

Some, but not all, of the following configuration questions appear on the worksheets you are instructed to fill out during the first two steps of the "Configuration and Reconfiguration Planning Procedure." The questions that appear depend on the type of host communication (your response to "101: Host Attachment" on page 3-11). Read and respond to only the questions that appear on the worksheets.

Planner: The following information for questions 099, 100, and 101 is needed to complete step 1 of the "Configuration and Reconfiguration Planning Procedure." Step 1 is located on page 3-5.

You must answer questions 100 and 101. Locate "Worksheet 1—Host Attachment" on page 20-3. Write your responses to questions 099, 100, and 101 on the worksheet.

099: Product Assistance Data

Response: Up to 68 alphanumeric characters.

A response to this question is optional. It is designed to provide you with a means of recording the name(s) and telephone number(s) of a person or persons to contact should there be problems with the control unit. You may leave blanks wherever you have not written an alphanumeric character.

100: 3174 Model Designation

Response:

01L	52R
01R	53R
02R	81R
03R	82R.
51R	

The model number is printed on the front of the control unit, next to the serial number. Enter the model number of the unit you are customizing for.

If you have a type 1 or type 2 Teleprocessing Communication Adapter (feature 3040, 3041, or 3043) in a Model 1L or 3R, or if you have a type 3 adapter (RPQ 8Q0575) in a Model 1R, 2R, 52R or 51R, consult Table 3-3 on page 3-11 to determine the alternate configurations that can be used for these models.

Table 3-3. Primary and Alternate Configurations for a 3174 Model 1L or 3R with a Type 1, 2, or 3 Teleprocessing Communication Adapter			
Model Number	Additional Adapter Type	Primary Configuration	Alternate Configuration
1L (without the 3270 Gateway feature)	Type 1 (3040 or 3041)	Model 1L	Model 1R
1L (without the 3270 Gateway feature)	Type 2 (3043)	Model 1L	Model 2R
1L (without the 3270 Gateway feature)	Type 3 (RPQ 8Q0575)	Model 1L	Model 3R
1L (with the 3270 Gateway feature)	Type 1 (3040 or 3041)	Model 1L (with the 3270 Gateway feature)	Model 1R (with the 3270 Gateway feature)*
1L (with the 3270 Gateway feature)	Type 2 (3043)	Model 1L (with the 3270 Gateway feature)	Model 2R (with the 3270 Gateway feature) ¹
3R	Type 1 (3040 or 3041)	Model 3R	Model 1R
3R	Type 2 (3043)	Model 3R	Model 2R

*This model can also be configured as a Model 1L without the 3270 Gateway feature if you use a customized Control disk of Configuration Support A.

101: Host Attachment

Response:

- | | |
|-----------------------------------|-------------------------|
| 1 = BSC | 5 = Local SNA* |
| 2 = SDLC and/or X.21 Nonswitched* | 6 = X.21 Switched |
| 3 = X.25 | 7 = Token-Ring Network. |
| 4 = Local Non-SNA | |

*This response is valid with or without the Token-Ring 3270 Gateway feature.

Note: A sheet of X.21 and X.25 Keyboard Labels (Order No. GX23-0285) may be shipped with the 3174. Provide one set of these labels from the sheet for each display station keyboard using X.21 or X.25 host attachment.

Planner: The following information is needed to complete step 2 of the "Configuration and Reconfiguration Planning Procedure." Return to step 2 on page 3-5 to determine the next worksheet you need to fill out.

104: Control Unit Address

Response: The two-digit control unit address.

Ask the system programmer at the host system location for this hexadecimal address. The host system recognizes this as the input/output (I/O) address.

Notes:

1. **BSC:** Obtain the polling address (in hexadecimal) for this control unit from the system programmer at the host site. *Be sure that it is the polling address, and not the line address.* Use Table 3-4 on page 3-13 to convert the BSC polling address to the control unit address (for example, if the BSC address [EBCDIC] is 4E, then the control unit address is 14). Do **not** convert the hexadecimal address to a decimal number, and be sure to ask the system programmer if the address is EBCDIC or ASCII.

Because it is standard practice to send the address twice, the system programmer may give you a “double address” (for example, 4040). Use only the first two digits (for example, 40).

2. **SDLC:** If the host access consists of VTAM/NCP, specify the control unit address on the ADDR operand of the NCP's PU statement also.
3. **X.25:** This is the X.25 secondary station address.
4. **Local Non-SNA:** The host system recognizes this as the lower (base) I/O address of the range of I/O addresses assigned to the terminals attached to the control unit. If 16 or fewer devices are attached, the following control unit addresses are valid: 00, 10, 20, 30, 40, 50, 60, 70, 80, 90, A0, B0, C0, D0, E0, F0. (If ASCII displays or printers are attached through the Asynchronous Emulation Adapter, they must be included in the total count of 16.) If more than 16 devices are attached (including ASCII), the following control unit addresses are valid: 00, 20, 40, 60, 80, A0, C0, E0.
5. **Local SNA:** This control unit address represents the I/O address of the SNA physical unit.
6. **Token-Ring 3270 Gateway:** The host system recognizes this as the lower (base) I/O address.
7. **X.21 Switched:** If the host access consists of VTAM/NCP, specify the control unit address on the ADDR operand of VTAM's switched PU statement.
8. This question does not apply for the **Token-Ring** host attachment.

Table 3-4. Conversion of BSC Polling Addresses into Control Unit Addresses		
BSC Hexadecimal Polling Address		Control Unit Address
EBCDIC	ASCII	
40	20	00
C1	41	01
C2	42	02
C3	43	03
C4	44	04
C5	45	05
C6	46	06
C7	47	07
C8	48	08
C9	49	09
4A	5B	10
4B	2E	11
4C	3C	12
4D	28	13
4E	2B	14
4F	21	15
50	26	16
D1	4A	17
D2	4B	18
D3	4C	19
D4	4D	20
D5	4E	21
D6	4F	22
D7	50	23
D8	51	24
D9	52	25
5A	5D	26
5B	24	27
5C	2A	28
5D	29	29
5E	3B	30
5F	5E	31

105: Upper Limit Address

Response: Two-character hexadecimal address.

The system programmer at the host system location will supply this address.

For SDLC and Local SNA without the Token-Ring 3270 Gateway Feature: 00 is the only valid response.

For Non-SNA: The upper limit address indicates the range of consecutive I/O addresses assigned to the terminals attached to the control unit.

Note: If this response is 00, the response to question 116 must be other than zero. If this response is nonzero, the response to question 116 must be 0.

For the Token-Ring 3270 Gateway: The upper limit address indicates the range of consecutive subchannel addresses (for local models) or SDLC station addresses (for remote models) assigned to represent the I/O address of Token-Ring Downstream Physical Units (DSPUs). Using the host access method, you must define one address for each "intelligent" work station and 3174 control unit attached to the ring communicating through this gateway. You must also define an address for the control unit you are customizing. For local models, these addresses must be defined contiguously at the host access method.

As an example: You have a Token-Ring Network with 40 DSPUs. The address of the control unit you are customizing is 10. Your response to question 104 would be 10, since that is the lower limit in the range of addresses. To find the upper limit add the number of devices (in hexadecimal). There are 40 devices (28 hexadecimal). Therefore the upper limit address is 38. See the following example.

Example

Decimal 40 (number of devices) = 28 hexadecimal

10 hexadecimal (the control unit address)
+ 28 hexadecimal (number of devices)

= 38 hexadecimal (the upper limit address)

Note that these responses are all hexadecimal characters.

The number of DSPUs defined dictates the amount of additional storage required. The "Storage Planning Procedure" on page 3-7 will help you determine the amount of additional storage you will need to support the number of DSPUs defined. (Table 3-2 on page 3-9 contains these storage requirements.) You will complete this procedure during the second part of the planning process.

Note: If your response is 00, or if your responses to questions 104 and 105 match, the Token-Ring panels will not appear during the Configure procedure.

Your response to question 105, minus your response to question 104, cannot be greater than X'8C' (140 decimal), which is the maximum number of DSPUs that can be supported on the Token-Ring Network.

106: Token-Ring Network Address of the 3174

Planner: Questions 106 and 107 apply to the remote models of the 3174 that attach to the Token-Ring Network. They do **not** apply to the Token-Ring Network 3270 Gateway feature in the 3174.

Response: Twelve-character hexadecimal address.

The address can be either a locally administered address, a universal address, or all zeros. A locally administered address is in the following format:

4000 XYYY YYYY

where X and Y are the user-assigned portion of the locally administered address. Note that X should not be greater than X'7'.

A universal address is in the following format:

WWWW WWZZ ZZZZ

W = the ID of the adapter manufacturer (for example, IBM's ID is 10005A).

Z = the unique address portion of this adapter's universal address.

Notes:

1. A response of all zeros will cause the Token-Ring adapter to operate with the universal address.
2. If the gateway that you are using is a 372x, you must define the Token-Ring Network addresses as locally administered addresses using dial digits (digits that can be dialed on the telephone) 0 through 9 **only**. The 372x will expect to be connected by way of telephone lines.
3. The response to this question cannot be the same as the response to question 107.

Warning: When the product permits you to enter either type of address, the suggested choice is locally administered. If the universal address is used and the Token-Ring adapter is replaced, the 3174, as well as the gateway, will have to be recustomized with the new address.

Ask your network planner for this address.

107: Token-Ring Network Address of the Gateway

Response: Twelve-character hexadecimal address.

The address can be either a locally administered address or a universal address. A locally administered address is in the following format:

4000 XYYY YYYY

where X and Y are the user-assigned portion of the locally administered address. Note that X should not be greater than X'7'.

A universal address is in the following format:

WWWW WWZZ ZZZZ

W = the ID of the adapter manufacturer (for example, IBM's ID is 1000 5A)

Z = is the unique address portion of this adapter's universal address.

Notes:

1. If the gateway that you are using is a 372x, you must define the Token-Ring Network addresses as locally administered addresses using dial digits (digits that can be dialed on the telephone) 0 through 9 **only**. The 372x will expect to be connected by way of telephone lines.
2. The response to this question cannot be all zeros, nor can it be the same as the response to question 106.

Ask your network planner for this address.

108: Unique Machine Identifier

Response: Seven alphanumeric characters.

Customization records that include the control unit serial number in the customization response make it easier to identify a machine for which you are keeping records. You may need these records later for diagnostic purposes. This serial number is located on the front panel of the control unit and consists of 7 alphanumeric characters. We recommend that you use these 7 characters as the unique machine identifier in your response.

If the control unit serial number is not available or you prefer not to use it, you may enter your own unique machine identifier of 7 alphanumeric characters. You may enter 0–9, A–Z, null, or space for the 7 characters.

110: Multiple Logical Terminals (MLTs) Configuration Level

Response:

0 = No MLT	3 = MLT Level 3
1 = MLT Level 1	4 = MLT Level 4
2 = MLT Level 2	5 = MLT Level 5.

The default response is 0.

Notes:

1. A response of 2 may require that additional storage be provided.
2. A response of 3 or higher will require that additional storage be provided and is not supported on models 81R and 82R.
3. If you have ASCII display stations with attached printers, you must specify a nonzero response for this question (110).
4. KB is equal to 1024 bytes.

“Determining the Level of MLT Support” on page 3-18 is a procedure that will help you determine which MLT level you will require. Perform this procedure now so you can determine the response you should specify for this configuration question. The “Storage Planning Procedure” on page 3-7 helps you to determine if you will require any additional storage to support the MLT level you have chosen. (Table 3-1 on page 3-9 contains these storage requirements.) The “Storage Planning Procedure” is performed during the second part of the planning process.

A nonzero response to this question configures control unit terminal (CUT) display stations to have the ability to interact with multiple host sessions. *The host sessions may be connected to a single IBM 3270 host or to one or more ASCII hosts.* For access to multiple sessions of the IBM 3270 host, port assignment must be performed (question 116). For access to ASCII host sessions, the control unit must have an Asynchronous Emulation Adapter (AEA) and the AEA Configure procedure must be performed.

The minimum level of MLT support that should be selected for the subsystem is determined by the following:

- Number of CUT display stations using the MLT function
- Screen size of the CUT display stations using the MLT function
- Number of host sessions (session limit) on each CUT display station (a maximum of five host sessions is permitted)
- Whether the display stations using the MLT function have extended attribute buffers (EABs)
- Whether the display stations using the MLT function are attached through a 7232 Dual Control Unit Terminal Multiplexer.

Determining the Level of MLT Support

To determine what level of support you should define, locate and fill in "Worksheet 23—Multiple Logical Terminals" on page 20-25.

Step 1: In the Device Type/Screen Size column, specify the device attached to that control unit port (for example, DFT, printer, or CUT). If the device is a CUT display station, include the screen size (for example, 24 × 80).

Note: If Feature 6 will be used on a CUT display station (for example, on a 3180 Model 6) and the display station user will be using MLT and changing the screen size, you must specify the largest screen size (for storage purposes).

Step 2: In the Session Limit column, specify the number of host sessions (3270 and ASCII) for the listed devices. *Printers have a maximum of 1; DFTs and CUTs, a maximum of 5.*

Warning: Each 3270 host session requires a host address. Local Non-SNA, BSC, or remote attached control units are permitted a maximum of 32 host addresses.

Step 3: In the 7232? column, specify whether the device is attached through a 7232 Dual Control Unit Terminal Multiplexer. *Specify a "Yes" or "No."*

Step 4: In the EAB? column, specify whether the CUT display stations have extended attribute buffers (EABs). *Specify a "Yes" or "No."*

Step 5: When you have completed filling in the preceding columns on the worksheet, you use Table 3-5 to determine how much storage should be reserved for each listed device. *Write in the amount of storage required for each device in the MLT Storage Required column.*

Table 3-5. MLT Storage Specification. Storage requirements are in KB.										
Device Type/Screen Size	Session Limit									
	1		2		3		4		5	
	Attached through a 7232?									
	No	Yes	No	Yes	No	Yes	No	Yes	No	Yes
Printer	0	0	0	0	0	0	0	0	0	0
DFT	0	0	0	0	0	0	0	0	0	0
CUT/24X80 (1920-Character) EAB	0	4	5	9	10	14	15	19	20	24
CUT/24X80 (1920-Character)	0	2	3	5	6	8	9	11	12	14
CUT/32X80 (2560-Character) EAB	0	8	9	17	18	26	27	35	36	44
CUT/43X80 (3440-Character) EAB										
CUT/27X132 (3564-Character) EAB										
CUT/32X80 (2560-Character)	0	4	5	9	10	14	15	19	20	24
CUT/43X80 (3440-Character)										
CUT/27X132 (3564-Character)										

Note: Add 1KB for every port assignment that has an ASCII display with an attached printer.

Step 6: After calculating the amount of storage each device requires for MLT support, add these amounts to determine the total amount of MLT storage required. Write in the total MLT storage amount required on the line at the bottom of the MLT Storage Required column.

Step 7: Using the total calculated amount of MLT storage required and *considering future expansion*, determine which level of MLT support you should select.

If the total storage required is	Select MLT level
64KB or less	1
128KB or less	2
416KB or less	3
864KB or less	4
1408KB or less	5

An example of a completed MLT Worksheet and selected response can be found in Figure 3-1.

Control Unit Port Number	Device Type/ Screen Size	Session Limit	7232? Yes/No	EAB? Yes/No	MLT Storage Required
26-00	CUT/24 X 80	2	Yes	No	5
26-01	3290 (DFT)	3	Yes	No	0
26-02	CUT/24 X 80	2	Yes	No	5
26-03	CUT/43 X 80	4	Yes	Yes	35
26-04	CUT/32 X 80	3	Yes	No	14
26-05	CUT/27 X 132	2	Yes	No	9
26-06	CUT/24 X 80	4	Yes	No	11
26-07	CUT/24 X 80	4	Yes	No	11
Total MLT Storage Required					90

Figure 3-1. An Example of Calculating the Total MLT Amount

In this example, 90KB is the total amount of storage required. Level 1 requires only up to 64KB and would therefore be insufficient. Level 2 of MLT reserves up to 128KB, which would be sufficient, but considering eventual expansion, you may decide to choose Level 3 support (416KB).

Related Considerations

- To use a 7232 Dual Control Unit Terminal Multiplexer for switching between control units, you must specify a response other than zero to this question.
- If the response to this question is other than zero, the response to question 116 must also be other than zero.
- Models 81R and 82R cannot have a response of 3 (MLT Support Level 3), or higher because of storage constraints.
- See question 125 for information on disabling the background alarm for the background sessions of CUT displays using the MLT function.
- For information on port addressing of the Multiple Logical Terminals (MLTs), see Chapter 4, "Planning for Port Assignment."

116: Individual Port Assignment

Response:

- 0 = No
- 1 = The user assigns the number of addresses per port, and the control unit defines the individual addresses.
- 2 = The user defines the individual addresses.

The default response is 0.

If you specify 0, then 32 addresses are automatically assigned on Models 1L, 1R, 2R, and 3R; or 16 addresses are assigned on Models 51R, 52R, and 53R; or eight addresses are assigned on Models 81R and 82R.

Enter a 1 or 2 if you:

- Answered question 110 with a nonzero response.
- Plan to assign port addresses on a port-by-port basis.
- Plan to have ASCII devices access 3270 hosts (Asynchronous Emulation Adapter must be present).
- Plan to use distributed function terminals (DFTs) with multiple interactive screens. (The 3290 Information Panel and the 3270 Personal Computer are some of the DFTs with MIS capability.)
- Plan to use a 7232 Dual Control Unit Terminal Multiplexer with printers, DFTs, or Programmed Symbol Set (PSS) display stations

See Chapter 4, "Planning for Port Assignment," if you require more information to determine your response.

117: Port Assignment

This is a panel that appears during the Configure procedure if question 116 is responded to with a 1 or 2. Chapter 4, "Planning for Port Assignment" contains the planning information you need to fill out the worksheet for this panel.

118: Port Address

This panel appears on the screen after the 117 panel. It displays the assigned port addresses in hexadecimal. You cannot enter information on this panel.

121: Keyboard Language and Character Set I/O Interface Code

Planner: You *must* respond with a 01 (the default) if you are configuring for the Asynchronous Emulation Adapter (AEA).

Response: Two digits that represent the keyboard language and I/O interface code that will be used in this cluster.

If you plan to answer question 123: Country Extended Code Page Support with a 1 (CECP Support), you must use one of the valid CECP (Country Extended Code Page) languages in Table 3-6 on page 3-21 when responding to question 121. If you do not plan to answer question 123: Country Extended Code Page with a 1, you may select any language from Table 3-6 when responding to question 121.

Keyboard Languages

Table 3-6. Keyboard Languages and Character Set I/O Interface Codes Supported		
Response	Keyboard Language	I/O Interface Code ⁶
01 ¹ (default)	English (U.S.) EBCDIC	English (U.S.) EBCDIC CECP
02 ²	English (U.S.) ASCII	ASCII-7
03	Austrian/German	Austrian/German CECP
04	Belgian	Belgian
05	Brazilian	Brazilian
07	Danish	Danish/Norwegian CECP
09	Finnish	Finnish/Swedish CECP
14	International	International
15	Italian	Italian CECP
16	Japanese (English)	Japanese (English)
17	Japanese (Katakana)	Japanese (Katakana)
19	Spanish	Spanish CECP
21	Spanish-speaking	Spanish-speaking CECP
22	English (U.K.)	English (U.K.) CECP
23	Norwegian	Danish/Norwegian CECP
24	Swedish	Finnish/Swedish CECP
25	EBCDIC (World Trade)	English (U.S.)
28	Portuguese	Portuguese CECP
29 ¹	Canadian (bilingual)	Canadian (bilingual) CECP
30	French AZERTY	French CECP
33 ³	English (U.S.) ASCII	ASCII/International
34 ⁴	English (U.S.) ASCII	ASCII-8
35	Cyrillic	Cyrillic
36	Greek	Greek
37	Icelandic	Icelandic
38	ROECE ⁵	ROECE/Latin
39	Turkish	Turkish
40	Yugoslavic	Yugoslavic
41	New Swiss French	Swiss French (New) CECP
42	New Swiss German	Swiss German (New) CECP
43	New Belgian	Belgian (New) CECP
46	Thai	Thai
47	Netherlands	English (U.S.) EBCDIC CECP

¹Alternate Keyboard Selection (132) is valid only with these languages.

²Available on remote models only. Does not support Extended Data Stream.

³Available on BSC, local SNA, and local non-SNA only.

⁴Available on SDLC and X.25 only.

⁵Regional Office for Eastern and Central Europe.

⁶See the 3174 Character Set Reference, GA27-3831, for the graphics and code page points.

123: Country Extended Code Page Support

Response:

- 0 = No CECP Support
- 1 = CECP Support (see Note 1).

The default response is 0.

If you respond to this question with a 1 (CECP Support), a larger definition of graphic characters than previous code pages will be supported, and the ability for multilingual communication will be improved.

Warning: Answering this question with a 1 can result in a loss of data integrity and cause unexpected characters to appear on the screen. You should become familiar with the *3174 Character Set Reference*, GA27-3831, before responding to this question with a 1.

Notes:

1. You must answer question 121 with one of the valid CECP (Country Extended Code Page) languages from Table 3-6 on page 3-21 if you plan to respond to question 123 with a 1.
2. See the *3174 Character Set Reference*, GA27-3831, for the supported devices.

125: Miscellaneous Feature Options

Response: Eight digits (0 or 1).

- 0 = No
- 1 = Yes.

The default response is 00000000.

Specify digits 1–3 and 5–8 as either a 0 or 1. Specify the default (0) for digit 4. Digits are numbered from left to right.

Digit	Description
1	Dual-Function Clear Key
2	Unsupported Control Code Translate
3	Clicker Option
4	Reserved
5	PS Load Altered Screen
6	File Transfer Aid
7	Background Alarm
8	Deferred Keystroking (Remote SNA Only)

Digit 1 - Dual-Function Clear Key:

Specify this digit as 1 to prevent the Clear key from putting a 3278, 3279, or 3180 display station into the default screen size mode.

Note: Specifying this digit as 1 will cause the Clear key to operate contrary to the definition given in the *IBM 3270 Information Display System Data Stream Programmer's Reference*, GA23-0059. Host applications written to conform with the *Data Stream Programmer's Reference* may react unpredictably.

Digit 2 - Unsupported Control Code Translate:

Specify this digit as 1 to translate the following interface codes into a hyphen character (EBCDIC X'60'):

01 through 04, 06, 07, 09, 0A, 0B, 0E, 0F, 10, 14, 16, 17, 18, 1A, 1B, 1F
20 through 27, 2A, 2B, 2D, 2E, 2F
30 through 3B, and 3D.

During READ operations, the hyphen character code returns to the host instead of the original code.

Notes:

1. Additionally, interface codes 3F and FF will be replaced by hyphens on non-EAB devices.
2. The above codes are reserved for future use in the IBM 3270 Data Stream. Host applications that transmit these codes as data with a write-type command or within an outbound 3270DS structured field are not in conformance with the *Data Stream Programmer's Reference* and may encounter unpredictable results.

Specifying this digit as 0 (default) causes the 3174 to reject the interface codes and display a PROG 402 in the operator information area of the display station, which receives a message containing one of the unsupported interface codes. Pressing the RESET key will clear the PROG 402 from the screen. Also, an Erase Write or Erase Write Alternate command from the host application will clear the PROG 402 from the screen.

Digit 3 - Clicker Option:

0 = Keyboard clicker is *off* when the display station is turned on.
1 = Keyboard clicker is *on* when the display station is turned on.

Digit 4 - Reserved Digit:

The fourth digit is reserved and defaults to 0.

Digit 5 - PS Load Altered Screen:

Specifying a 1 inhibits screen flashing during a load PS.

Digit 6 - File Transfer Aid:

The operation of DFT devices is not affected by this option.

A response of 1 is required for:

- Operation of the IBM Personal Computer with an IBM 3278/79 emulation card or equivalent performing file transfer. This includes the IBM 3270 Personal Computer operating in CUT mode.
- Operation of the 3814 Switching Management System.
- Operation on the AEA using FTTERM (IBM File Transfer/Terminal Emulator Program).

If 1 is specified, the operation of other CUT (non-IBM PC) devices may be degraded.

Digit 7 - Background Alarm:

0 = Background alarm is allowed.

1 = Background alarm is disabled for background sessions.

This option has effect only when question 110 (MLT) has been configured with a nonzero response.

Each MLT display will have one foreground session and one or more background sessions. The foreground session is the one currently displayed on the terminal screen; the others are background sessions. Host updates to background sessions may include sounding the alarm. This option allows the background alarms to be disabled.

Note: This alarm is automatically disabled if digit 6 (File Transfer Aid) has been responded to with a 1.

Digit 8 - Deferred Keystroking - Remote SNA:

0 = Deferred keystrokes will be discarded between segments within a request unit (RU).

1 = Deferred keystrokes will be processed between segments within a request unit (RU).

Note: Performance will be degraded if you respond to this question with a 1.

127: Response Time Monitor (RTM) Definition

Response: Two digits. If one digit is zero, the other must also be zero.

The default response is 00 (no RTM support).

Note: If your response to this question is nonzero, you **must** fill out "Worksheet 13—128: RTM."

Turn to Chapter 5, "Planning for Response Time Monitor (RTM)" for information on planning for RTM, how to fill out the worksheet, and the possible responses to question 127. Your system programmer will help you select your responses.

128: RTM Boundaries and Interface Specification

During the Configure procedure, this host-related panel appears if your response to question 127 was nonzero. Chapter 5, "Planning for Response Time Monitor (RTM)" has the planning information you need to fill out the worksheet for this panel.

132: Alternate Base Keyboard Selection

Response: Four digits (A value of 0, 1, or 2 for each).

- 0 = No
- 1 = Yes (keyboard without numeric lock)
- 2 = Yes (keyboard with numeric lock—valid for 8K1038 and 8K1158 keyboards only).

The default response is 0000.

Note: For a description of numeric lock, see "Numeric Lock Feature Option" in the *3174 Functional Description, GA23-0218*.

Your response to question 132 specifies the alternate keyboard layouts (if any) that you want configured in the system. If you leave question 132 set to the default, the layout of the keyboards attached to the control unit will be used.

Base keyboards 8K0808 and 8K0932 are mutually exclusive. If you select Base keyboard 8K0808 or 8K0932, all standard typewriter keyboards are replaced. This affects keyboards that emulate a standard typewriter keyboard. If the 3174 control unit is customized for RPQ 8K0808 Base keyboards, 3270 terminal emulation will not work for ASCII display stations. If you select Base keyboard 8K1158, all standard APL keyboards are replaced.

In determining which keyboards you have, you can either refer to Table 3-7 on page 3-26, which lists the Microcode RPQs associated with the different keyboards, or to Appendix B, "Keyboard and Keypad Layouts."

Digit	Description
1	8K0808 Base Keyboard
2	8K0932 Base Keyboard (3178-C4)
3	8K1038 Base Keyboard (3178-C3)
4	8K1158 Base Keyboard

Notes:

1. Base keyboards 8K0808, 8K0932, 8k1038, and 8K1158 do not require RPQ microcode to operate.
2. Responding with a 1 to digit 3 (8K1038) and digit 4 (8K1158) will result in the PF keys being operational in the lower shift position.

Table 3-7. Microcode RPQ Numbers Associated with Keyboards		
Microcode RPQ Numbers	Supported?	Response
8k0809	Yes	First digit = 1
8K1162	Yes	First digit = 1
8K0931	Yes	Second digit = 1
8K1034	No	See 8K1230
8K1035	No	See 8K1255
8K1163	Yes	Second digit = 1
8K1164	No	For Typewriter keyboard see 8K1230
	Yes	For APL keyboard fourth digit = 1
8K1165	No	For Typewriter keyboard see 8K1255
	Yes	For APL keyboard fourth digit = 2
8K1166	No	See 8K1164
8K1230	Yes	Third digit = 1
8K1231	No	See 8K1255
8K1245	No	See 8K1255
8K1255	Yes	Third digit = 2

136: Modifiable Keyboards: Standard Layouts

Planner: Answer questions 136, 137, and 138 only if the 3174 cluster includes a display station that has a modifiable keyboard and is operating in native mode. For additional information on modifying keyboards, see Chapter 11, "Planning to Modify Keyboards."

Most keyboards are modifiable in native mode; see your terminal user's guide for instructions on setting up your terminal.

Response: Four digits (0 or 1)

- 0 = No
- 1 = Yes.

The default response is 0000.

Digit	Description
1	Converged Typewriter keyboard
2	Converged APL keyboard
3	Converged Data Entry keyboard
4	Enhanced Typewriter keyboard

For modifiable keyboards, there are four standard keyboard translate tables on the Control disk: Converged Typewriter, Converged APL, Converged Data Entry, and the Enhanced Typewriter keyboard. Additionally, by using the Modify Keyboards procedure, you can create as many as four modified versions of these layouts. However, the total number of modifiable keyboard layouts (standard and modified) that you select to use for any cluster cannot exceed 4 (a combination of responses to questions 136 and 137).

Your response to this question specifies the standard modifiable keyboard layouts that you want configured in the system. Enter a 1 in the response field for each standard modifiable keyboard layout that you want configured in the system. If you specify all four standard keyboard layouts here (response = 1111), you cannot select any modified keyboard layout in question 137.

For illustrations of the standard modifiable layouts, turn to Appendix B, "Keyboard and Keypad Layouts."

Note: If you have a 3174 Model 1L with microcode Release Level S1.0 of the Token-Ring Network 3270 Gateway feature, you cannot modify the Enhanced Typewriter keyboard.

137: Modifiable Keyboard: Modified Layouts

Response: Four digits (0 or 1).

- 0 = No
- 1 = Yes.

The default response is 0000.

See the "Planner" note on 3-26.

Digit	Description
1	Keyboard ID: A
2	Keyboard ID: B
3	Keyboard ID: C
4	Keyboard ID: D

Your response to question 137 specifies the modified keyboard layouts that you want configured in the system. Each layout consists of a keyboard/keypad combination that you can identify with the letter A, B, C, or D. You define the modified layout that the keyboard ID represents by selecting the Modify Keyboards procedure listed on the Master Menu.

Enter a 1 in the response field for the ID(s) that you either plan to define or have already defined. This will configure the layout assigned that ID in the system.

You can select the Modify Keyboards procedure either before or after the Configure procedure. See Chapter 11, "Planning to Modify Keyboards" for directions for defining a modified layout.

The total number of keyboard layouts selected in questions 136 and 137 cannot exceed 4.

138: Modifiable Keypad: Standard Layouts

Planner: *This question applies only to unmodified, Converged, or Enhanced keyboards in native mode (see your terminal user's guide). If the keyboard is being operated in emulation mode, this question does not apply for these display stations.*

Response

- 0 = National Language Numeric Keypad
- 1 = Data Entry Keypad
- 2 = Program Function Keypad.

The default response is 0.

See the "Planner" note on 3-26.

These responses specify the type of keypad to be used with the standard keyboard layout(s) you selected in question 136. The Enhanced Typewriter keyboard does not have a modifiable keypad if you have Release Level 1 of the Token-Ring Network 3270 Gateway feature; therefore, if your response to question 136 was 0 0 0 0 or 0 0 0 1, use the default. (A National Language Numeric keypad is the one supplied for the national language that you specified in question 121.) If you selected one to four types of keyboard layout in question 136, you can select one keypad here to be used with all of them.

Appendix B, "Keyboard and Keypad Layouts" will help you distinguish these keypads.

141: Magnetic Character Set

Response

- A = None
- B = Numeric
- C = Alphanumeric (auto entry for secure data only)
- D = Alphanumeric (auto entry for all data).

The default response is A.

Your response specifies the type of magnetic character set (if any) that has been installed.

Note: Your response must be A if your response to question 121 was 35 (Cyrillic), 38 (ROECE), 40 (Yugoslavic), or 46 (Thai).

165: Compressed Program Symbols

Response

- 0 = Do not send compressed Programmed Symbols data
- 1 = Send compressed Programmed Symbols data.

The recommended setting for 3174 remote models is 1.

The recommended setting for 3174 local models is 0.

Compressing data on a locally attached 3174 could degrade performance. For distributed function terminals, you do not need to specify a 1. For more information on compressed Programmed Symbols data, see the *3174 Functional Description*, GA23-0218.

166: Attribute Select Keyboard

Response

- A = None of the keyboards listed below
- B = One or more of the keyboards listed below, *without* numeric lock
- C = One or more of the keyboards listed below, all *with* numeric lock.

The default response is A.

The response specifies whether any of these keyboards is being used:

- Attribute select typewriter base keyboard (feature 4651)
- Attribute select typewriter/APL base keyboard (feature 4652)
- Typewriter overlay base keyboard (feature 4640).

To distinguish these keyboards, see Appendix B, "Keyboard and Keypad Layouts."

Note: Your response must be A if your response to question 121 was 02 (English-U.S. ASCII), 35 (Cyrillic), 38 (ROECE), 40 (Yugoslavic), or 46 (Thai).

168: Additional Extension-Mode Key Definition (Personal Computers)

Planner: Answer this question only if the 3174 has personal computers (PCs) attached that use 3270 CUT mode emulation programs **and** either:

- The MLT function will be used, **or**
- The ASCII emulation function will be used.

Response

- 0 = No additional extension-mode key is defined
- 1 = Home key is the additional extension-mode key
- 2 = Print ID key is the additional extension-mode key.

The default response is 0.

Many 3270 terminal emulation programs that run on PCs do not completely emulate all the keystrokes available on a 3278 or 3279 CUT display station; for example, many key sequences that require an ALT Shift are ignored by the emulation program and not sent to the 3174. Therefore, an additional extension mode (similar to an ALT Shift) is required so that PCs with 3270 emulation programs can use the 3174 MLT change-screen and ASCII-emulation functions.

The response to this question defines an additional key used to enter keyboard extension mode. For possible alternatives to defining this additional extension-mode key, see the *Terminal User's Reference for Extended Functions*, G126-0220.

A response of 1 or 2 to this question changes the function of either the Home key or the Print ID key on 3278 and 3279 keyboards as well as on keyboards that emulate the 3278 or 3279 keyboards. For that reason, do not specify a nonzero response unless the additional function is required to support a PC 3270 emulation program providing CUT mode operation. If the Home key is selected as the additional extension-mode key, access to the Home function is changed; the Home key must be pressed twice to return the cursor to Home. The Print ID key is affected in the same way if it is selected as the additional extension-mode key.

The Home key is the recommended extension-mode key; Home is normally an unshifted key on PC keyboards and provides easier operator access.

Note: This question will affect all base keyboards (for example, 3278 or 3279 keyboards) and all keyboards emulating 3278 type keyboards. It will not affect IBM Converged or Enhanced Typewriter keyboards unless those keyboards are used in 3278 or 3279 emulation mode.

173: Distributed Function Terminal (DFT) Options

Response: Eight digits (0 or 1).

- 0 = No
- 1 = Yes.

The default response is 00000000. Digits are numbered from left to right. The DFT devices include the:

- IBM 3179 G Color Graphic Display Station
- IBM 3192 G Color Graphics Display Station
- IBM 3193 Display Station
- IBM 3194 Display Terminal
- IBM 3290 Information Panel
- IBM 3270 Personal Computer.

If you do not have one of these devices, use the default.

Digit	Description
1	Enable Local Copy Format Controls
2	Automatic Form Feed before Local Copy
3	Automatic Form Feed after Local Copy
4	Reserved
5	Reserved
6	Field Intensity Option
7	Field Intensity Option
8	Update Panel before Allowing Buffer Change

Digit 1 - Enable Local Copy Format Controls:

DFT devices generate an SNA-character-string data stream to perform a local copy operation to a printer. If the printer does not have Save/Restore Format capability and is operated in shared mode (in shared mode, local copy operation is permitted between brackets of a host communication), there is a possibility that the local copy operation will destroy the format controls established by the host program. Appropriate specification of this digit establishes format controls. If a printer supports Save/Restore Format, this option has no effect: the DFT device will send format controls.

If this digit is set to 0 (default), the DFT device will not send format controls to a printer that lacks Save/Restore Format capability. Set this digit to 0 for those operating environments where the host program does not reestablish format controls with each Begin Bracket. This is true for SNA only. Note that the format of the local copy output depends on the format controls established by the operator and/or host program.

When this digit is set to 1, the DFT device will send format controls to the printer even though the printer lacks Save/Restore capability. This will enable the local copy output to duplicate, as closely as possible, the character image being copied from the DFT device. Set this digit to 1 for those operating environments where the printer is not operated in shared mode and/or the host program reestablishes format controls with each Begin Bracket.

Digit 2 - Automatic Form Feed before Local Copy:

Specify this digit as 0 if you do *not* want the printer to generate an automatic form feed before a local copy operation is performed via the DFT data stream.

Specify this digit as 1 if you want the printer to generate an automatic form feed before a local copy is performed via the DFT data stream.

Digit 3 - Automatic Form Feed after Local Copy:

Specify this digit as 1 if you want to generate an automatic form feed after a local copy operation is performed via the DFT data stream.

Specify this digit as 0 if you do *not* want to generate an automatic form feed after a local copy operation is performed via the DFT data stream.

Digits 4 and 5 - Reserved:

The fourth and fifth digits are reserved and defaulted to 0.

Digits 6 and 7 - Field Intensity Options - 3290:

Use the sixth and seventh digits to specify the field intensity option. Specify these digits as either 00 or 11 if you want the 3290 to underscore all fields carrying the field intensity attribute.

Specify these digits as 01 if you do *not* want the 3290 to underscore or display in reverse video the fields carrying the field intensity attribute.

Specify these digits as 10 if you want the 3290 to display in reverse video the fields carrying the field intensity attribute.

Digit 8 - Update Panel before Allowing Buffer Change - 3290:

Specify this digit as 0 if you want the 3290 to suspend panel updating to process a host transmission. If this digit is set to 0, under high-data-rate conditions the host messages placed in the display buffer may be overlaid with new data before they are displayed on the panel.

When this digit is set to 1, the contents of the display buffer must be displayed on the panel before new data can be placed in the display buffer. Set this digit to 1 when the 3290s are being used as system consoles or for other applications where potentially high message rates are possible and the user must visually interpret all data sent by the host.

175: Distributed Function Terminal (DFT) Password

Response: A six-digit numeric password.

Define a six-digit password. This password is used in 3290 setup level 3 every time permanent changes are made to the 3290 logical terminal definition table. The default is 000000. For more information, see the *3290 Information Panel Description and Reference, GA23-0021*, or the *3290-2 Information Panel Description and Reference, GA23-0241*.

176: BSC Enhanced Communication Option: Distributed Function Terminals

Response

- 0 = No
- 1 = Yes.

The default response is 0.

To specify a 1, you must have distributed function terminals attached to the 3174.

In addition:

- Your system programmer should confirm that your host system is capable of handling enhanced 3270 BSC protocols in response to outbound transmissions of BSC WACK.
- You use one of the following IBM licensed programs, which support BSC WACK:
 - ACF/NCP Version 1, Release 2 or higher (CICS/VS and IMS/VS using VTAM or TCAM and ACF/NCP are supported)
 - ACF/VTAM with Communication Adapter Support (4331, 4361, and 9370)
 - CICS/VS Version 1, Release 6 and higher using BTAM
 - VM/370 SP, Release 3 and higher.

If you use IMS/VS with BTAM, TCAM, or ACF/TCAM with the Communication Controller's Emulation Program (EP), you must specify 0.

Consult with your system programmer for this information. Be sure that the licensed programs you use are at compatible release levels and support the required display functions.

178: 7232 Dual Control Unit Terminal Multiplexer Switching

Planner: Respond to this question only if you will be attaching devices that support a Programmed Symbols Set (PSS) through a 7232.

To customize for 7232 Dual Control Unit Terminal Multiplexer support, you must have responded to question 110 (MLT) with a nonzero value. If possible, PSS devices should not be attached to the 3174 control unit through a 7232.

Response:

- 0 = Switching permitted on all devices (no PSS support on PSS devices attached through the 7232)
- 1 = Switching permitted only on devices without PSS (PSS is supported on devices attached through the 7232).

The default (0) allows switching between control units at the various terminals, provided that the necessary addressing is done through Port Assignment.

213: Between Bracket Printer Sharing

Response:

- 0 = No Between Bracket Printer Sharing
- 1 = Between Bracket Printer Sharing allowed.

The default response is 1.

Select 0 if you are not using local copy or if all printers on the Printer Authorization Matrix are defined in "local mode" (you do not want the host to use the local copy printers for direct print operations). Select 1 if some printers on the Printer Authorization Matrix are defined in "shared mode" (some printers will be shared for both local copy and host printing).

For more information on local copy, see Chapter 10, "Planning to Define the Printer Authorization Matrix (PAM)."

215: Physical Unit Identification

Response Five alphanumeric characters.

The default response is 00000.

The physical unit identification (PUID) is a 5-character hexadecimal code; the only valid characters are A–F and 0–9. Each PUID in a network should be unique.

You can obtain the PUID from the system programmer. The PUID identifies the control unit to the host in response to an SDLC XID command. The PUID is required if the 3174 will operate on a switched data link.

220: Alert Function

Response:

- 0 = No alert function
- 1 = Alert function without operator-generated alert message capability
- 2 = Alert function with operator-generated alert message capability from port 0 only
- 3 = Alert function with operator-generated alert message capability from all ports.¹

The default response is 0.

Alert is an SNA-only function that requires the NetView™ program, Version 1.1 or higher, at the host. If Alert has been specified, the 3174 will attempt to send, to the host, alert data for all errors that have not affected the integrity of the host adapter, the 3174 processor, control storage, or the control program itself. The 3174 sends alert data, based on the subsystem status codes (SSCs) it generates, in a session between a system services control point (SSCP) and a physical unit (PU). The alert information flows through the Network Communication Control Facility (NCCF) to the NetView program. The NetView program determines which alert data is significant and maintains a data base of alert information based on the filters in effect for devices throughout the network. The NetView program data base is used for problem determination and failure isolation.

An operator-generated alert message is a skeleton message called up by an operator, who fills it in with installation-specific information. For an operator-generated alert message to be processed correctly, the NetView program at the host must be set up to receive the message. See the *3174 Functional Description* for details on sending an operator-generated alert message.

222: Support of Command Retry

Planner: Configuration questions 222, 223, 224, and 225 need to be answered only if you are planning for a 3174 Model 1L. If you are planning for a remote 3174 model, you can skip these questions and continue with question 310.

Table 3-8 on page 3-35 is a matrix of the customizing parameters and host systems for which the 3174 Model 1L is supported. The matrix applies to SNA and non-SNA attachments. Use this matrix as a reference when answering questions 222, 224, and 225.

Response

- 0 = No support of command retry
- 1 = Support of command retry.

The default response is 0.

Select the command retry option only if the 3174 is connected to a channel equipped with the command retry feature. The system programmer can supply this information. With this function, when certain error conditions are detected, the 3174 can request the channel to retry a command.

¹ Distributed function terminals cannot issue an operator-generated alert message.

NetView is a trademark of the International Business Machines Corporation.

The following information explains the contents of Table 3-8.

Command Retry:

If command retry is enabled, the 3174 initiates a retry request for all Bus Out parity checks detected during write data transfer sequences.

Data Transfer Modes:

The channel adapter in the 3174 can transfer data in two different modes:

- Data Chained Interlocked (DCI) – Interlocked single tag
- High-Speed Transfer (HST) – Interlocked double tag

High-Speed Transfer is more likely to achieve the 1.25-megabyte data transfer rate than DCI.

Channel Burst Size:

The 3174 transfers data in an interlocked mode at a rate of 1.25 megabytes, or 0.8 microsecond per byte. The channel burst size default value is 32. The consequences of specifying larger burst sizes can be determined only by calculating the critical wait times of other control units and devices attached to the same byte multiplexer channel. Exceeding the wait times of the other devices may cause them to overrun and/or otherwise degrade their performance. Consult with your account systems engineer if you are not able to determine what burst size should be set.

The burst size selected for operation on a block multiplexer channel does not affect the data transfer rate, because a block channel forces burst mode.

Table 3-8. Host-Channel Attachment Information			
Host System and Channel Type	Command Retry (Question 222)	Mode of Data Transfer (Question 224)	Channel Burst Size (Question 225)
4331 Byte Multiplexer	No	High-Speed Transfer	32
4331 Block Multiplexer	Yes	High-Speed Transfer	NA
4341 Byte Multiplexer	Yes	High-Speed Transfer	32
4341 Block Multiplexer	Yes	High-Speed Transfer	NA
4361 Byte Multiplexer	Yes	High-Speed Transfer	32
4361 Block Multiplexer	Yes	High-Speed Transfer	NA
4381 Byte Multiplexer	Yes	High-Speed Transfer	32
4381 Block Multiplexer	Yes	High-Speed Transfer	NA
303x Byte Multiplexer	No	Normal Transfer	32
303x Block Multiplexer	Yes	High-Speed Transfer	NA
308x Byte Multiplexer	No	High-Speed Transfer	32
308x Block Multiplexer	Yes	High-Speed Transfer	NA
3090 Byte Multiplexer	No	High-Speed Transfer	32
3090 Block Multiplexer	Yes	High-Speed Transfer	NA

223: Attention Delay Value

Response: A two-digit number that represents the delay value in whole milliseconds. The response range is 10–99.

The default response is 10.

See the “Planner” note on 3-34.

The attention delay function increases the probability of including more than one path information unit (PIU) per read channel program and reduces the number of unsolicited attentions presented to the channel. This function queues inbound data during the specified delay period and then presents one attention at the end of the delay period. The system programmer can supply this information.

Note: Attention delay is not implemented for the Token-Ring Network 3270 Gateway feature. Any response entered for this question will have no effect when the gateway feature is used.

224: Mode of Data Transfer

Response

- 0 = Interlocked mode; normal data transfer
- 2 = Interlocked mode; high-speed data transfer.

The default response is 2.

See the “Planner” note on 3-34.

Select option 2 if the 3174 connects to a channel equipped with the high-speed transfer feature. The system programmer can supply this information.

225: Channel Burst Size

Response applicable only for local byte multiplexer operation:

- | | |
|-------------------------|--------------------------|
| 0 = 002 bytes per burst | 4 = 032 bytes per burst |
| 1 = 004 bytes per burst | 5 = 064 bytes per burst |
| 2 = 008 bytes per burst | 6 = 256 bytes per burst |
| 3 = 016 bytes per burst | 7 = 512 bytes per burst. |

The default response is 4.

See the “Planner” note on 3-34.

For a 3174 byte multiplexer attachment, a response of 7 provides optimal 3174 performance. A lower value may be required, however, for overall byte multiplexer channel operation when other control units share the same channel. See a system programmer familiar with system tuning for assistance in selecting an appropriate value for the system configuration.

Planner: *If you are filling out*

- *Worksheet 2, 3, 4, 5, or 8, continue responding to the following configuration questions that appear on your worksheet.*
- *“Worksheet 6—Local (Non-SNA),” return to the “Configuration and Reconfiguration Planning Procedure” and see step 4 on page 3-6 to determine the next worksheet to fill out.*
- *“Worksheet 7—Local (SNA),” return to the “Configuration and Reconfiguration Planning Procedure” and see step 3 on page 3-6 to determine the next worksheet to fill out.*

You may also refer to the “3174 Quick-Reference Guide for Planners” to determine where to proceed next.

Keep records of your configuration using one of the methods described in Chapter 2, “Keeping Records.”

310: Connect-Data-Set-to-Line (CDSTL) Operation

Response:

- 0 = Operation on a nonswitched line, **or**
Operation on a switched line in the U.S. or Canada, **or**
Operation in data terminal ready/data set ready (DTR/DSR) mode in countries other than Canada, **or**
Connection via the CCITT V.35 interface, **or**
Connection using X.21 or X.25
- 1 = Connection on a switched line via the CCITT 108.1 interface operating in the connect-data-set-to-line (CDSTL) mode.

The default response is 0.

313: NRZ or NRZI Encoding

Response:

- 0 = Use nonreturn to zero (NRZ) encoding
- 1 = Use nonreturn to zero inverted (NRZI) encoding.

The default response is 0.

This parameter must be compatible with the host system communication controller and/or the modem. Specify NRZI encoding only for SDLC host communication. Ask the system programmer which response you should specify.

317: Telecommunication Facilities

Response:

- 0 = Nonswitched facilities
- 1 = Half-duplex SNBU operation
- 2 = Switched networks.

The default response is 0.

Note: Respond to question 317 with the default if your connection to the host does not require a modem.

To respond to this question, you need to know:

- Whether the modem in your installation is operating in *full-duplex*² (4- or 2-wire) or *half-duplex* (2-wire) in its primary facility, and
- Whether the modem is operating in *full-duplex* (4- or 2-wire) or *half-duplex* (2-wire) in its secondary facility, and
- The type of communication line that is being used (nonswitched or switched).

Use Table 3-9 to determine your response.

Primary Modem Operation	Secondary Modem Operation	Communication Line Type	Response	Further Requirements
Full-duplex	Full-duplex	Nonswitched	0	None
Half-duplex	Half-duplex	Nonswitched	0	None
Full-duplex	Half-duplex	Nonswitched	0	Backup Control Disk*
Full-duplex or Half-duplex	Full-duplex or Half-duplex	Switched	2	None

*On the backup Control disk, respond to question 317 with a 1 and respond to question 340 with a 0. Responses to all other customization questions should be the same on both Control disks.

0 = Nonswitched facilities: Select this response for operation via modem or direct-connection attachment to certain hosts or control units such as a 3710, 3720, 3721, 3725, 3726, 4361, or 8100 where a modem is not required.

1 = Half-duplex SNBU operation: Select this response for the backup Control disk configuration when the modem supports half-duplex RTS protocol on the secondary facility and supports full-duplex RTS protocol on the primary facility.

2 = Switched networks: Select this response for operation in point-to-point mode on the public switched telephone network (PSTN).

Note: Option 2 is not valid for BSC or the 3270 Token-Ring Network Gateway feature on remote models.

² Also called *duplex*.

318: Full- or Half-Speed Transmission

Response:

- 0 = Full-Speed Transmission
- 1 = Half-Speed Transmission.

The default response is 0.

Enter a 0 if full-speed transmission operation is desired. Enter a 1 if half-speed transmission operation is desired.

If the speed capability can be controlled by the local or host modem, it is recommended that a 0 be entered and that the modem control the speed. (This parameter must be compatible with the host system communication controller and/or the modem.)

If the 3174 controls the capability to operate in either full-speed or half-speed mode, two Control disks may be generated (as described in Chapter 15, "How to Copy Files"), one for full-speed operation and one for half-speed operation. To switch speeds, IML the other Control disk.

Note: To determine if the operating speed can be controlled by the modem, refer to the documentation for your modem.

332: X.25 Options

This a host-related panel that appears during the Configure procedure if your response to 101 was 3. The responses entered on this panel customize the microcode for X.25 support. Chapter 6, "Planning for X.25" contains the planning information needed to fill out the X.25 Options worksheet.

340: RTS Control Response Options

Response:

- 0 = Controlled Request-to-Send (RTS)
- 1 = Permanent Request-to-Send
- 2 = BSC special controlled Request-to-Send.

The default response is 0.

To respond to this question, you will need to know:

- Whether the modem in your installation is operating in *full-duplex* (4- or 2-wire) or *half-duplex* (2-wire) in its primary facility, and
- Whether the modem is operating in *full-duplex* (4- or 2-wire) or *half-duplex* (2-wire) in its secondary facility, and
- The type of communication line that is being used (nonswitched or switched).

Use Table 3-10 on page 3-40 to select your response.

Table 3-10. Response Selection For Question 340				
Primary Modem Operation	Secondary Modem Operation	Network Type	Response	Further Requirements
Full-duplex	Full-duplex	SDLC or BSC	1	None
Half-duplex	Half-duplex	SDLC or BSC	0	None
Half-duplex	Half-duplex	BSC	2 ²	None
Full-duplex	Half-duplex	SDLC	1	Backup Control Disk ¹
Full-duplex	Half-duplex	BSC	1	Backup Control Disk ¹

¹On the backup Control disk, respond to question 340 with a 0 and respond to question 317 with a 1. Responses to all other customization questions should be the same on both Control disks.

²If the host modems use the NEW SYNC feature, selecting 2 may cause transmission errors. If you are in doubt about whether your host modems use the NEW SYNC feature, enter a 0.

Planner: *If you are filling out*

- *Worksheet 3, 4, 5, or 8, continue responding to the following configuration questions that appear on your worksheet.*
- *“Worksheet 2—BSC,” return to the “Configuration and Reconfiguration Planning Procedure” and see step 4 on page 3-6 to determine the next worksheet to fill out. You may also refer to the “3174 Quick-Reference Guide for Planners” to determine where to proceed next.*

Keep records of your configuration using one of the methods described in Chapter 2, “Keeping Records.”

360: X.21 Switched Retry (Models 2R, 52R, and 82R Only)

Response:

- 00 = X.21 Switched feature not in use, **or** Retry not in use
- 01–99 = Number of times to retry an incoming or outgoing call after the initial attempt is unsuccessful.

The default response is 00. You must use a two-digit response. Where necessary, use a leading zero (for example, 04 for 4 retries).

361: X.21 Switched Retry Timing (Models 2R, 52R, and 82R)

Response:

- 00 = X.21 Switched feature not in use, **or** Retry not in use
- 01–20 = Two-digit number that specifies the number of seconds between the retries specified in question 360.

The default response is 00. You must use a two-digit response. Where necessary, use a leading zero (03 for 3 seconds).

362: X.21 Switched Options

Response: Eight digits (0 or 1).

- 0 = No
- 1 = Yes.

The default response is 00000000. Digits are numbered from left to right.

Digit	Description
1	Direct Key
2	Dial Key
3	Local, Communicate Key
4	Immediate Disconnect Key
5	Extension Key
6	Delayed Disconnect Key
7	DCE Supported for Direct Calls
8	DCE Supported for Address Calls

If you are not using the X.21 Switched feature, use the default (00000000).

The response to this question defines what X.21 keyboard options can be used on the terminals attached to any ports other than port 0. Each digit allows or disallows one of the keyboard options.

Local, Communicate Key:

The third digit determines whether the control unit can disconnect from the data communication equipment (DCE).

Extension Key:

The fifth digit allows access to all other X.21 keys, and so it must be specified as 1 if the other keys are to be used.

Disconnect Key:

The fourth and sixth digits determine whether the operation of the Disconnect key will be immediate or delayed. The choices are:

XXX0X0XX: Pressing the Disconnect key immediately performs the disconnect operation on port 0 only. (The fourth and sixth digits are 0.)

XXX1X0XX: Pressing the Disconnect key immediately performs the disconnect operation on *all* ports. (The fourth digit is 1, and the sixth digit is 0.)

XXX0X1XX: The user must press the Disconnect key twice in order to disconnect on port 0 only. (The fourth digit is 0, and the sixth digit is 1.)

XXX1X1XX: The user must press the Disconnect key twice in order to disconnect on *all* ports. (The fourth and sixth digits are 1.)

Access to Direct and Dial keys:

Port 0 always has access to all the X.21 options except for the Direct and Dial keys (first and second digits). Port 0 access to Direct and Dial depends on the status of the DCE as defined in the seventh digit (direct calls) and in the eighth digit (address calls):

- **DCE Supported for Direct Calls:** If you specify the seventh digit as 1, port 0 supports the Direct key.
- **DCE Supported for Address Calls:** If you specify the eighth digit as 1, port 0 supports the Dial key.
- If you specify both the seventh and eighth digits as 1, port 0 supports both the Direct and Dial keys.

To use the X.21 feature, you must specify either or both of the seventh and eighth digits as 1, depending on which DCE support is used.

Example: 00011001 indicates that the Immediate Disconnect key (fourth digit specified as 1) and the Extension key (fifth digit specified as 1) can be used on all terminals attached to the 3174. All the terminals support the DCE for address calls (eighth digit specified as 1). The Extension key (fifth digit) is specified as 1 so that the other X.21 keys can be used.

365: X.21 Data Transfer Delay (Models 2R, 52R, 82R)

Response:

- 0 = Not applicable
- 1 = No delay
- 2 = Data Transfer Delay (X.21 nonswitched only).

The default response is 0.

Note: For all models other than 2R, 52R, and 82R, respond with the default (0).

Select 1 for:

- X.21 switched operation, **or**
- X.21 leased operation if the DTE connection at the host end of the network is through an X.21 interface (for example, not through X.21 bis).

Select 2 when:

- The DTE connection at the host end of the network is through X.21 bis, **or**
- The 3174 connection to the network is through an "X.21 multipoint" DCE.

Response 2 provides a delay of 24-bit times in the transition from the X.21 Data state to the X.21 Data Transfer state. This delay prevents loss of data in the attachments described above.

Planner: If you are filling out

- Worksheet 4, 5, or 8, continue responding to the following configuration questions that appear on your worksheet.
- “Worksheet 3—X.25,” return to the “Configuration and Reconfiguration Planning Procedure” and see step 3 on page 3-6 to determine the next worksheet to fill out. You may also refer to the “3174 Quick-Reference Guide for Planners” to determine where to proceed next.

Keep records of your configuration using one of the methods described in Chapter 2, “Keeping Records.”

367: X.21 Switched Short-Hold Mode

Response:

- 0 = No
- 1 = Yes.

Short-Hold Mode is an automatic facility that disconnects the X.21 switched link between a primary station and a secondary station whenever there is a break in the data traffic. It reconnects the link as soon as there is more data to send. This facility was formerly 3274 RPQ 740497.

368: X.21 Switched Short-Hold Mode Dial Number

Response: Up to 14 numeric characters.

Enter the dial number of the 3174. This field must be completed if the response to question 367 is equal to 1. If the response to this question does not fill the entire field, leave underscores or blanks wherever you have not written a character.

370: Maximum Inbound I-Frame Size

Response:

- 0 = 265 Byte Maximum I-Frame
- 1 = 521 Byte Maximum I-Frame.

The default response is 0.

When large amounts of data are being transmitted, network performance and speed can be improved by responding to this question with a 1.

The I-Frame size includes the length of the transmission header (TH) and request or response header (RH). For example, if the maximum length of a request unit (RU) segment is 512, then the I-frame size is 521 (512 + 9 for the TH and RH).

Planner: *If you are filling out*

- *Worksheet 8, continue responding to the following configuration questions.*
- *“Worksheet 4—SDLC” or “Worksheet 5—X.21 Switched,” return to the “Configuration and Reconfiguration Planning Procedure” and see step 3 on page 3-6 to determine the next worksheet to fill out. You may also refer to the “3174 Quick-Reference Guide for Planners” to determine where to proceed next.*

Keep records of your configuration using one of the methods described in Chapter 2, “Keeping Records.”

380: Maximum Receive I-Frame Size

Planner: *The remaining configuration questions in this chapter pertain to the Token-Ring Network. If you need additional information to answer these questions, see your Token-Ring Network documentation.*

Response: Four numeric characters.

The default response is 2042; a valid response ranges from 265 to 2042 bytes. Where necessary, use a leading zero (0265 for 265).

Notes:

1. If your gateway is the 3174 Token-Ring Network 3270 Gateway feature, the response to this question should match the F-field response in question 941. (See Chapter 9 for information on question 941.)
2. The response to this question is dependent upon your gateway and ring configuration. For additional information, see Chapter 9, “Planning the Token-Ring Network 3270 Gateway.”
3. The I-frame size should include the length of the transmission header (TH) and response header (RH). For example, if the maximum length of a request unit (RU) segment is 1024, the I-frame size specified should be 1033 (1024 + 9 for the TH and RH).

381: Token-Ring Network Maximum In

Response: One numeric character.

The default response is 1; a valid response ranges from 1 to 7.

This may also be referred to as the *receive window size*.

Notes:

1. If your gateway is the 3174 Token-Ring Network 3270 Gateway feature, the response to this question should be equal to or less than the W-field Maximum Out (Transmit Window Size) specified in question 941. (See Chapter 9 for information on question 941.)
2. The response to this question is dependent upon your gateway and ring configuration. This field specifies the maximum number of link level I-frames that the 3174 receives before transmitting an acknowledgment.

Relationship between Questions 381 and 941

Token-Ring Network performance is enhanced by the values assigned to the Transmit Window Size (question 941) and the Receive Window Size (question 381). (See Chapter 9 for information on question 941.)

It is strongly recommended that you set 381 to 1. This ensures that each received frame is acknowledged. (Very little congestion is added to Token-Ring Network traffic by the acknowledgment.)

The W-field (Transmit Window Size) of question 941 should be set greater than 381. A value of 2 or 3 is recommended for single ring Token-Ring Networks. If bridges are included, a value of 4 should be considered. These values will permit uninterrupted transmission by eliminating wait for acknowledgments and will keep buffer resources in the gateway from being depleted.

Never set the W-field of question 941 to less than question 381's response. This causes a wait for acknowledgments and, thus, degraded performance.

382: Maximum Transmission I-Frame Size

Response: Four numeric characters.

The default response is 0521; a valid response ranges from 265 to 2042 bytes. Where necessary, use a leading zero (0521 for 521 bytes).

Notes:

1. The response to this question is dependent upon your gateway and ring configuration.
2. The I-frame size should include the length of the transmission header (TH) and response header (RH). For example, if the maximum length of an RU segment is 1024, the I-frame size specified should be 1033 (1024 + 9 for the TH and RH).

383: Token-Ring Network Maximum Out

Response: One numeric character.

The default response is 2; a valid response ranges from 1 to a maximum of 7 (based on the associated I-frame size). See Table 3-11.

Table 3-11. Token-Ring Network Maximum Out	
I-Frame Size Entered Transmit	Token-Ring Network Maximum Out
265 <= X <= 521 bytes	7
522 <= X <= 1033 bytes	7
1034 <= X <= 2042 bytes	4

This may also be referred to as the *transmit window size*.

Note: The response to this question is dependent upon your gateway and ring configuration. This field specifies the maximum number of link level I-frames that the 3174 transmits before waiting for an acknowledgment.

Planner: *This is the end of the regular configuration questions. Return to the "Configuration and Reconfiguration Planning Procedure" and see step 3 on page 3-6 to determine the next worksheet to fill out. You may also refer to the "3174 Quick-Reference Guide for Planners" to determine where to proceed next.*

Keep records of your configuration using one of the methods described in Chapter 2, "Keeping Records."

Planning to Reconfigure

At a later date, you may want to reconfigure (change some responses to the configuration questions). The planning process for reconfiguring is almost the same as for configuring.

Host Panel

Follow the "Configuration and Reconfiguration Planning Procedure" on page 3-5 to plan your reconfiguration.

117: Port Assignment Panel

If you have changes to make to the Port Assignment, see "Changing Port Assignments" in Chapter 4. The table under that heading explains how to fill out "Worksheet 12–117: Port Assignment."

128: RTM Panel

If you have changes to make to the Response Time Monitor, see "Changing the RTM Specifications" in Chapter 5. The table under that heading explains how to fill out the RTM Worksheet.

332: X.25 Options Panel

If you have changes to make to the X.25 Options, see "Changing the X.25 Options" in Chapter 6. The table under that heading explains how to fill out the X.25 Options Worksheet.

What's Next?

Return to the "Configuration and Reconfiguration Planning Procedure," and see step 3 on page 3-6 to determine the next worksheet you need to fill out. You may also refer to the "3174 Quick-Reference Guide for Planners" to determine where to proceed next.

Chapter 4. Planning for Port Assignment

Getting Ready to Plan for Port Assignment	4-3
Which Response to Question 116 Should You Specify?	4-3
A Response of 0	4-3
A Response of 1	4-4
A Response of 2	4-4
Considerations	4-5
For DFT	4-5
For CUT	4-5
For AEA	4-5
Who Assigns the Terminals to the Ports?	4-6
Completing Worksheet 12—117: Port Assignment When 116=1	4-9
Completing Worksheet 12—117: Port Assignment When 116=2	4-10
118: Port Address Table	4-11
Changing Port Assignments	4-12
What's Next?	4-12

Getting Ready to Plan for Port Assignment

The information in this chapter will help you to complete step 4 of the “Configuration and Reconfiguration Planning Procedure.” Step 4 is located on page 3-6.

Before you start, you will need the following:

- “Worksheet 12—117: Port Assignment” on page 20-14
- Information about the terminals to be attached to the 3174
- Information about which terminal is assigned to which port.

Which Response to Question 116 Should You Specify?

Individual port addressing saves host addresses because you define those ports that you will use. The Port Assignment procedure is used to define 3270 host sessions for all types of devices: 3270 display stations and printers, as well as ASCII display stations and printers.

Planner: *If you are planning to allow communication with ASCII devices through the Asynchronous Emulation Adapter (AEA), it is strongly recommended that you plan the AEA configuration before planning for Port Assignment. For additional information, see Chapter 8, “Planning for the Asynchronous Emulation Adapter.”*

There are three possible responses to question 116. These responses are discussed below. If you need help choosing a response, see “Considerations” on page 4-5.

A Response of 0

If your response to question 116 is 0, you do not select individual port assignment. Instead, the customizing program automatically assigns addresses for each port of the control unit, even if all the ports will not have display stations or printers connected to them. When operating in non-SNA, unused addresses take up channel address space.

Note: You cannot respond with a zero if you are planning to customize for

- DFTs using the multiple interactive sessions capability
- CUTs using the Multiple Logical Terminals function
- ASCII terminals accessing the 3270 host.

Proceed to “A Response of 1” on page 4-4 and “A Response of 2” on page 4-4 for information on how to respond to question 116 and how to plan for port assignment of these displays.

A Response of 1

If you specify $116=1$, you define the number of host addresses per port and let the customizing program assign the addresses.

The customizing program assigns the addresses in ascending order. First, each port you select to use receives its *primary address*. Then, those ports assigned DFTs that are using the multiple interactive sessions capability or CUTs that are using the MLT function receive secondary addresses. The secondary addresses begin where the primary addresses leave off. For example, if addresses 2 through 15 are primary addresses, the first secondary address assigned will be 16.

Planner: *If you have specified that $116=1$, go to page 4-9 and begin the procedure for filling out the Port Assignment worksheet.*

A Response of 2

If you specify $116=2$, you assign host addresses for each port of the 3174 control unit. You can assign the addresses in any order, skipping addresses between ports.

First, you assign the *primary address*. Then, for those ports assigned DFTs that are using the multiple interactive sessions capability or CUTs that are using the MLT function, you assign secondary addresses. The secondary addresses begin where the primary addresses leave off. For example, if you assign addresses 2 through 15 as primary addresses, the first secondary address you can assign will be 16.

Planner: *If you have specified that $116=2$, go to page 4-10 and begin the procedure for filling out the Port Assignment worksheet.*

Considerations

For DFT

The **multiple interactive sessions capability** allows DFT display stations to interact with multiple logical terminals. Each logical terminal has its own host address and can interact independently with its own host program. When assigning addresses to ports supporting DFTs, you should check the DFT supporting documentation regarding the number and type of sessions supported for that DFT; for example, a DFT may support only three host sessions and one printer session.

For CUT

The **Multiple Logical Terminals (MLT) function** allows CUT displays to interact with multiple logical terminals. Each logical terminal has its own host address and can interact independently with its own host program. For CUTs using the MLT function, consult "Worksheet 23—Multiple Logical Terminals," to ensure that you do not exceed the amount of storage reserved to support these displays; the session limit on this worksheet indicates the number of planned host sessions for each CUT display.

For AEA

The AEA allows communication between 3270 and ASCII display stations, printers, and hosts in several ways: 3270 display stations can communicate with ASCII printers and hosts, 3270 printers can receive information from ASCII display stations and hosts, ASCII display stations can communicate with 3270 printers and hosts, and ASCII printers can receive information from 3270 display stations and hosts.

- ASCII Display Stations and Printers

For an ASCII display or printer to communicate with the 3270 host, the display or printer must have a 3270 host address assigned to the AEA port to which it is attached; if you do not assign a 3270 host address, the display user will not be permitted to connect to the 3270 host from the Connection Menu.

- ASCII Display Stations with Printers

For a printer attached to an ASCII display station to communicate with a 3270 host, two 3270 host addresses must be assigned to the AEA port. If a second address is not defined, only the ASCII display station will be allowed to communicate with the 3270 host.

- 3270 Display Stations and Printers

In order for a 3270 display or printer to communicate with the 3270 host, a 3270 host address must be assigned to the Terminal Adapter (TA) port to which the display or printer is attached.

If a CUT display is using the MLT function, it will be able to connect to the 3270 host only on the logical terminals for which a 3270 host address has been assigned.

Examples of 3270 Host Addressing Restrictions for the AEA

- If you specify the 3270 host as the first session and the Connection Menu for the next two sessions on “Worksheet 22—AEA Default Destination,” a display user will not be able to connect to the 3270 host for the two Connection Menu sessions unless you assign 3270 host addresses for those sessions. When 116 = 1, enter 3 in the #IS column; when 116 = 2, assign LT1, LT2, and LT3.
- If you specify the 3270 host as the first session, the Connection Menu as the second session, and the 3270 host as the third session, you **must** assign a 3270 host address to all three sessions. When 116 = 1, enter 3 in the #IS column; when 116 = 2, assign LT1, LT2, and LT3. Skipping addresses on a port is not permitted.

Who Assigns the Terminals to the Ports?

In some establishments, the person who plans for customizing assigns the terminals to the ports and then communicates the assignments to the site planner. In others, the site planner assigns the terminals to the ports and communicates that information to the person who plans customizing (because that person will be customizing for port assignment or defining the Printer Authorization Matrix).

If you are responsible for assigning terminals to ports, you can record the port assignment data for the site planner on the Cabling Worksheets after you have finished planning to customize for individual port assignment. These worksheets are included in *3174 Site Planning*. These worksheets are designed to keep records of the port connections and to communicate that information between the site planner and the person who plans customizing.

If you responded to question 116 with a 1 or 2, the 117: Port Assignment panel appears on your screen during the Configure procedure (see Figure 4-1). “Worksheet 12—117: Port Assignment” corresponds to this panel. On the panel and worksheet, you assign the number of logical terminals per port connection.

117: Port Assignment

CC #IS	LT1 P	LT2 S1	LT3 S2	LT4 S3	LT5 S4	CC #IS	LT1 P	LT2 S1	LT3 S2	LT4 S3	LT5 S4
26-00 1	---	---	---	---	---	26-01 0	---	---	---	---	---
26-02 0	---	---	---	---	---	26-03 0	---	---	---	---	---
26-04 0	---	---	---	---	---	26-05 0	---	---	---	---	---
26-06 0	---	---	---	---	---	26-07 0	---	---	---	---	---
26-08 0	---	---	---	---	---	26-09 0	---	---	---	---	---
26-10 0	---	---	---	---	---	26-11 0	---	---	---	---	---
26-12 0	---	---	---	---	---	26-13 0	---	---	---	---	---
26-14 0	---	---	---	---	---	26-15 0	---	---	---	---	---
26-16 0	---	---	---	---	---	26-17 0	---	---	---	---	---
26-18 0	---	---	---	---	---	26-19 0	---	---	---	---	---
26-20 0	---	---	---	---	---	26-21 0	---	---	---	---	---
26-22 0	---	---	---	---	---	26-23 0	---	---	---	---	---
26-24 0	---	---	---	---	---	26-25 0	---	---	---	---	---
26-26 0	---	---	---	---	---	26-27 0	---	---	---	---	---
26-28 0	---	---	---	---	---	26-29 0	---	---	---	---	---
26-30 0	---	---	---	---	---	26-31 0	---	---	---	---	---
21-00 0	---	---	---	---	---	21-01 0	---	---	---	---	---
21-02 0	---	---	---	---	---	21-03 0	---	---	---	---	---
21-04 0	---	---	---	---	---	21-05 0	---	---	---	---	---
21-06 0	---	---	---	---	---	21-07 0	---	---	---	---	---
22-00 0	---	---	---	---	---	22-01 0	---	---	---	---	---
22-02 0	---	---	---	---	---	22-03 0	---	---	---	---	---
22-04 0	---	---	---	---	---	22-05 0	---	---	---	---	---
22-06 0	---	---	---	---	---	22-07 0	---	---	---	---	---
23-00 0	---	---	---	---	---	23-01 0	---	---	---	---	---
23-02 0	---	---	---	---	---	23-03 0	---	---	---	---	---
23-04 0	---	---	---	---	---	23-05 0	---	---	---	---	---
23-06 0	---	---	---	---	---	23-07 0	---	---	---	---	---

(. . . Message Area . . .)

PF: 3=Quit 4=Default 7=Back 8=Fwd 9=RtnH 10=Page Back 11=Page Fwd

Figure 4-1. The Port Assignment Panel

Each of the fields is described below.

- LT = 000** After you have completed the worksheet and the responses have been entered on the panel, this field displays the total number of logical terminals (assigned addresses).
- 116 = n** This field displays your response to question 116. The *n* is replaced by your response (1 or 2).
- CC/MMM/HOST** CC is the control unit address. MMM is the model number. HOST is the method of host attachment (for example, BSC, SDLC, and so on).

Planning for Port Assignment

C@	This column lists the port numbers assigned to terminals, beginning with port 26-00. The prefix "26" indicates that these terminals are directly or indirectly connected to the terminal adapter (TA) cards, identified by Hardware Group 26. The prefixes "21," "22," and "23" indicate that these terminals are directly or indirectly connected to the Asynchronous Emulation Adapter (AEA) cards, identified by Hardware Groups 21, 22, and 23.
#IS	This column defines the number of 3270 host addresses to be assigned to each port. For a DFT, or CUT display using the MLT function, this number must correspond to the number of logical terminals requiring connections to the 3270 host. For any other type of terminal (including AEA attached terminals), the number is either 0, 1, or 2 (2 is for AEA displays with attached printers). The default for port 26-00 is a 1; the default for ports 26-01 through 26-31, 21-00 through 21-07, 22-00 through 22-07, and 23-00 through 23-07 is 0. The default can be changed to a number between 1 and 5 for all 26-xx ports, but can be changed only to a 1 or 2 for the 21-xx, 22-xx, and 23-xx ports.
LT1/P	This field shows the primary address of the display station or printer assigned to the port. <i>This field corresponds to the "LT1" response area on "Worksheet 22—AEA Default Destination."</i>
LT2—LT5/S1—S4	This field shows the <i>secondary addresses</i> for DFTs and CUTs using the MLT function or the printer address for AEA displays with attached printers. The combined total of primary and secondary addresses should equal the number of 3270 host sessions. Secondary addresses for ports 21-00 through 21-07, 22-00 through 22-07, or 23-00 through 23-07, are assumed to be for printers attached to displays. <i>These fields correspond to the "LT2" through "LT5" response areas on "Worksheet 22—AEA Default Destination."</i>
Message Area	Operator messages appear here. The messages, which begin with a 4-digit code, inform you of the progress of your activities. If there is a problem, the message will explain it.
PF Keys	The functions of the PF keys are explained in Chapter 13 under "How to Configure the Control Disk" on page 13-10.

Completing Worksheet 12—117: Port Assignment When 116 = 1

If your response to question 116 is 1, you select the ports you will use and define the number of addresses per port. The 3174 customizing program assigns the primary and secondary addresses automatically.

1. Locate "Worksheet 12—117: Port Assignment" on page 20-14. You will partially complete this worksheet.

Note: If you have not read the previous information in this chapter, you need to do so before you begin to fill out the worksheet.

2. **#IS Column:** In the #IS column, write the number of addresses (0 to 5) next to each port to which you want to assign addresses. Write a number next to each port. If you do not want to use a port for a 3270 host session, write a 0.

Note: This number must represent the total number of 3270 host sessions desired to support the CUT or DFT.

You can assign a printer or DFT to port 26-00, but if you do you cannot request a local copy to the printer or recustomize. To recustomize, you will be required to replace the DFT or printer with a CUT display.

- For the Models 51R and 52R, you can assign terminals only to ports 26-00 through 26-15 and to ports 21-00 through 21-07.
- For the Model 53R, you can assign terminals only to ports 26-00 through 26-15.
- For the Models 81R and 82R, you can assign terminals only to ports 26-00 through 26-07.

In the following example, DFTs or CUTs (with MLT support) are assigned to ports 26-02, 26-06, and 26-12. Ports with an entry of zero in the #IS column will not be used for 3270 host sessions.

_____ 117: Port Assignment _____

LT=000																					
	LT1	LT2	LT3	LT4	LT5		LT1	LT2	LT3	LT4	LT5		LT1	LT2	LT3	LT4	LT5				
C@	#IS	P	S1	S2	S3	S4	C@	#IS	P	S1	S2	S3	S4	C@	#IS	P	S1	S2	S3	S4	
26-00	1	___	___	___	___	___	26-01	0	___	___	___	___	___	26-02	4	___	___	___	___	___	___
26-02	4	___	___	___	___	___	26-03	0	___	___	___	___	___	26-04	0	___	___	___	___	___	___
26-04	0	___	___	___	___	___	26-05	0	___	___	___	___	___	26-06	3	___	___	___	___	___	___
26-06	3	___	___	___	___	___	26-07	0	___	___	___	___	___	26-08	1	___	___	___	___	___	___
26-08	1	___	___	___	___	___	26-09	0	___	___	___	___	___	26-10	0	___	___	___	___	___	___
26-10	0	___	___	___	___	___	26-11	0	___	___	___	___	___	26-12	2	___	___	___	___	___	___
26-12	2	___	___	___	___	___	26-13	0	___	___	___	___	___								

3. Do not exceed the port assignment limitations for your protocol:
 - With SNA protocol (SNA Local, SDLC, X.25, X.21 Switched, Token-Ring Network), up to 184 addresses can be assigned in the range from 2 to 254.
 - With non-SNA protocol (non-SNA Local or BSC), the addresses range from 0 to no more than 31.

Note: If you define a Printer Authorization Matrix, check that the printers (with the exception of local copy printers) are assigned addresses on the worksheet.

Completing Worksheet 12—117: Port Assignment When 116 = 2

If your response to question 116 is 2, you assign in decimal values the primary and secondary addresses that you want to use for each port. Then, the customizing program automatically generates the #IS field.

1. Locate “Worksheet 12—117: Port Assignment” on page 20-14. You will partially complete this worksheet.

Note: If you have not read the previous information in this chapter, you need to do so before you begin to fill out the worksheet.

2. **Address Columns (LT1/P, LT2/S1, LT3/S2, LT4/S3, LT5/S4):** Under the address column headings, write the addresses in decimal values. You can assign the addresses in random order, but be careful not to repeat any addresses. You can skip addresses between ports, or skip ports, but you cannot skip logical terminals on the same port. If there is no address to specify, leave the field empty on the worksheet.

- For the Models 51R and 52R, you can assign terminals only to ports 26-00 through 26-15, and 21-00 through 21-07.
- For a Model 53R, you can assign terminals only to ports 26-00 through 26-15.
- For the Models 81R and 82R, you can assign terminals only to ports 26-00 through 26-07.

3. **You can assign a printer or DFT to port 26-00, but if you do you cannot request a local copy to the printer or recustomize.** To recustomize, you will be required to replace the DFT or printer with a CUT display.

When you assign multiple addresses to a port, assign them consecutively: LT1/P, LT2/S1, LT3/S2, LT4/S3, LT5/S4. You cannot skip over a logical terminal: for example, assign LT1/P, LT3/S2, LT4/S3, but not LT2/S1. The logical terminal numbers themselves do not need to be sequential; for example, 7, 9, 5, 15 is an acceptable sequence.

In the following example, DFTs or CUTs (with MLT support) are attached to ports 26-00, 26-02, and 26-06. No terminal is attached to port 26-04 for access to a 3270 host session.

117: Port Assignment													
LT=000													
C@	#IS	P	S1	S2	S3	S4	C@	#IS	P	S1	S2	S3	S4
26-00	2	3					26-01	0					
26-02	5	7	8	9			26-03	0					
26-04	0						26-05	0					
26-06	12	13	14	15	16		26-07	0					
26-08	18						26-09	0					
26-10	19						26-11	0					
26-12	0						26-13	0					

4. Do not exceed the port assignment limitations for your protocol:

- For SNA protocol (SNA Local, SDLC, X.25, X.21 Switched, and Token-Ring Network), up to 184 addresses in the range from 2 to 254 are permitted. The first address you can assign is 2.
- For non-SNA protocol (non-SNA Local or BSC), the addresses range from 0 to 31. The first address you can assign is 0.

Note: If you define a Printer Authorization Matrix, check that the printers are assigned addresses on "Worksheet 12—117: Port Assignment."

Planner: You have completed "Worksheet 12—117: Port Assignment."

Return to the "Configuration and Reconfiguration Planning Procedure" and see step 4 on page 3-6 to determine if there are additional worksheets you need to fill out before going to the next step. You may also refer to the "3174 Quick-Reference Guide for Planners" to determine where to proceed next.

Keep records of your configuration by using one of the methods described in Chapter 2, "Keeping Records."

If you need to communicate these port assignments to the site planner, use the Cabling Worksheets in 3174 Site Planning, which explain how to enter the port assignments on the worksheet.

118: Port Address Table

During customizing, when you complete and verify the 117 panel and press PF8 to go forward, the port address table (118 panel) automatically appears on your screen. It enables you to verify that the entries you made in the port assignment specification table (117 panel) have been incorporated into the control unit address tables. The 118 panel is totally protected and displays (in hexadecimal) the assigned port addresses that were entered in decimal on the 117 panel. Hexadecimal representation will be required in system generation at the host and is useful to the IBM service representative in problem analysis. Here is an example of a port address table, with the addresses in hexadecimal:

118: Port Address													
LT=000													
C0	#IS	P	S1	S2	S3	S4	C0	#IS	P	S1	S2	S3	S4
26-00	1	02					26-01	0					
26-02	3	06	07	08			26-03	0					
26-04	0						26-05	0					
26-06	2	0A	0B				26-07	0					

You cannot change any entries on the 118 panel directly; the 118 panel is for display only. You must return to the 117 panel to make any changes. The changes will then be reflected in the 118 panel when it is redisplayed. You may copy the 117 and/or 118 panel for your records by using the local copy function.

Changing Port Assignments

Once you have customized the Control disk, you can change the configuration at any time by adding or removing displays or printers. Doing so may require changes to the 117 panel. When the 117 panel is displayed on your screen, you can type the new or changed entries in the #IS column or the address columns.

If you previously specified 116=1, and you need to *reconfigure* because you are adding or removing terminals, the host system must totally rework its address tables. For example, if you add one display, the secondary address may become a primary address associated with a different port (and perhaps a different device type as far as the host system is concerned). To avoid this rework, respecify 116=2. You can then keep the addresses assigned when 116=1 and add new addresses or change old addresses.

If you change your response to question 116 on the host panel, this may require a change to the 117 panel. The following table explains how to fill out the 117: Port Assignment panel on the worksheet if you have changed your response to question 116.

Change (116)	Result (117)
Your previous response was 116=0 and you changed it to 116=1.	Fill in the #IS column.
Your previous response was 116=0 and you changed it to 116=2.	Fill in the address columns (LT1/P, LT2/S1, ...) with decimal values.
Your previous response was 116=1 and you changed it to 116=0.	Previously defined addresses will be erased and the customizing program will automatically assign new addresses.
Your previous response was 116=1 and you changed it to 116=2.	The assigned addresses will not be erased. You can add new addresses or you can delete or replace (use decimal values) the previous assigned addresses in address columns (LT1/P, LT2/S1, ...).
Your previous response was 116=2 and you changed it to 116=0.	Previously defined addresses will be erased and the customizing program will automatically assign new addresses.
Your previous response was 116=2 and you changed it to 116=1.	Previously defined addresses will be erased. Fill in the #IS columns with new values.

What's Next?

Return to the "Configuration and Reconfiguration Planning Procedure," and see step 4 on page 3-6 to determine if there are any additional worksheets you need to fill out before going to the next step. You may also refer to the "3174 Quick-Reference Guide for Planners" to determine where to proceed next.

Chapter 5. Planning for Response Time Monitor (RTM)

Getting Ready to Plan for Response Time Monitor	5-3
An Overview of Response Time Monitor	5-3
127: RTM Definition	5-3
First-Digit Response	5-4
Second-Digit Response	5-5
128: RTM Boundaries and Interface	5-7
How Is Response Time Measured?	5-9
Sample Boundary Specifications	5-9
Valid Boundaries	5-9
Invalid Boundaries	5-10
Filling Out Worksheet 13—128: RTM	5-11
Changing the RTM Specifications	5-12
What's Next?	5-12

Getting Ready to Plan for Response Time Monitor

The information in this chapter will help you to complete step 4 of the “Configuration and Reconfiguration Planning Procedure.” Step 4 is located on page 3-6.

Before you start, you will need the following:

- “Worksheet 13—128: RTM” on page 20-15
- Information from your system programmer to select your responses.

An Overview of Response Time Monitor

The Response Time Monitor (RTM) function is a tool for network management, used to measure and evaluate response times. The RTM function measures and records the response time from the recognition of the inbound Attention Identifier (AID) request in the 3174 until the end of the transaction. Depending on how the 3174 is customized, RTM information can be obtained either by a network management application in the host or by a subsystem display station operator, or both. For a detailed description of the RTM function and the distributed function terminal (DFT) interface, see the *3174 Functional Description*.

Response times can be measured for all display terminals that attach to the 3174, but DFT terminals require a special interface.

The display of response times at the 3174 cluster level does not require any host programming support. However, RTM has a host interface for SNA communication. Host programming support (Network Logical Display Manager, Release 2 or higher) is available for setting RTM parameters from a host and for collecting and displaying RTM information at a NetView or Network Communication Control Facility (NCCF) operator station.

For BSC and non-SNA channel communication, response times are displayed only at the 3174 cluster level.

127: RTM Definition

In your two-digit response to question 127, you determine whether there is host support and where the RTM data is displayed, and you define the end of the transaction. If you specify a zero (“no RTM support”) for one digit of your response, the other digit must also be zero.

Planner: *If you specify a nonzero response to this question, you must complete “Worksheet 13—128: RTM.” This worksheet is filled out in step 4 of the “Configuration and Reconfiguration Planning Procedure.” Step 4 is located on page 3-6.*

Performing the procedure on page 5-11 will help you to complete “Worksheet 13—128: RTM.” The panel that corresponds to this worksheet will be displayed on your screen during the Configure procedure.

First-Digit Response

The first digit of your response to question 127 determines whether RTM is configured with host support and where the RTM data is displayed.

- 0 = No RTM support (default).
- 1 = RTM without host support. On port 26-00 only, the operator can:
 - Display RTM log information via the /1,1 Test
 - Display the Last Transaction Time indicator
 - Reset the RTM data via the /4,1 Test.
- 2 = RTM without host support. On all ports, the operator can:
 - Display RTM log information via the /1,1 Test¹
 - Display the Last Transaction Time indicator
 - Reset the RTM data via the /4,1 test.
- 3 = RTM with host support (Local [SNA], SDLC, X.25, Token-Ring Network). You cannot display RTM log information or the Last Transaction Time indicator on any port at the 3174 cluster level. The host may alter the authorization to display RTM log information at any time.
- 4 = RTM with host support (Local [SNA], SDLC, X.25, Token-Ring Network). On port 26-00 only, the operator can:
 - Display RTM log information in Test mode¹
 - Display the Last Transaction Time indicator.The host may alter the authorization to display RTM log information at any time.
- 5 = RTM with host support (Local [SNA], SDLC, X.25, Token-Ring Network). On all ports, the operator can:
 - Display RTM log information in Test mode¹
 - Display the Last Transaction Time indicator.The host may alter the authorization to display RTM log information at any time.

¹ DFT terminals cannot display the RTM log.

Second-Digit Response

The second digit of your response to question 127 determines what will be measured.

0 = No RTM support (default).

1 = **First Character:** The measurement is terminated when the first command of the next outbound message is written to the terminal. This command can be:

- Write, Erase/Write, or Erase/Write Alternate
- Erase All Unprotected
- Load Programmed Symbols
- Erase Reset
- Set Window Origin
- Activate Partition
- Create Partition
- Destroy Partition
- Reset Partition
- BSC Copy.

Note: A Write with or without data terminates the RTM measurement. The foregoing are examples of outbound communication that could possibly be expected to modify the contents of the presentation space.

2 = **Keyboard Unlocked:** For SNA devices, measurement is terminated when the next outbound operation (other than a Read) to the terminal contains a Change Direction/End Bracket (CD/EB) or explicit or implicit keyboard restore (WCC = keyboard restore or EAU command).

In non-SNA:

- For terminals such as the 3278 or 3279 display stations, measurement is terminated:
 - On end of transmission (EOT) for BSC. Exception: Upon receipt of a BSC Copy command, the measurement is terminated on the *from* device, once the screen image has been stored in the control unit. At this point, the *from* device is available for the operator to use. The *to* device in the BSC Copy will still have the measurement terminated at EOT.
 - On end of command chain.
- For distributed function terminals, such as the 3290 Information Panel, the 3179 Color Graphics Display Station, and the IBM 3270 Personal Computer, measurement is terminated upon receipt of a Terminate Chained Command Sequence (TCCS).

- 3 = **CD/EB:** This definition is valid only in an SNA environment. The measurement is terminated upon receipt of a Change Direction (CD) or End Bracket (EB), which puts the terminal into a Send or Contention state, respectively. This is usually equivalent to a “time-to-last-character.”

Notes:

1. EB or CD received in an exception response request or in a definite response causes the last in chain (LIC) segment to terminate the measurement.
 2. CD in conjunction with a Read does not stop the timer.
- 4 = **Last Character:** This definition measures from the pressing of an AID key to receipt of the last character of the last message prior to the pressing of the next AID key.

In non-SNA:

For terminals such as the 3278 or 3279 display stations, measurement is terminated:

- On end of transmission (EOT) for BSC. Exception: Upon receipt of a BSC Copy command, the measurement is terminated on the *from* device, once the screen image has been stored in the control unit. At this point, the *from* device is available for the operator to use. The *to* device in the BSC Copy will still have the measurement terminated at EOT.
- On end of command chain.

In SNA:

- Measurement is terminated on receipt of CD/EB (change direction or end bracket).

Note: This new transaction-end definition applies only to attached CUT-mode terminals. RTM support is disabled for DFT devices if this new RTM type is selected by the host or during 3174 customization. DFT devices do not support this new transaction-end definition.

128: RTM Boundaries and Interface

There are two versions of the 128: RTM panel; the one displayed on the screen during the Configure procedure depends on your first-digit response to question 127.

- Version A (Figure 5-1) appears if the first digit was 1 or 2. It allows you to specify the time boundaries for the RTM counters.
- Version B (Figure 5-2) appears if the first digit was 3, 4, or 5. This panel provides fields for specifying a flag for setting host interface status and fields for setting the time boundaries.

Both versions of these panels are represented on "Worksheet 13—128: RTM."

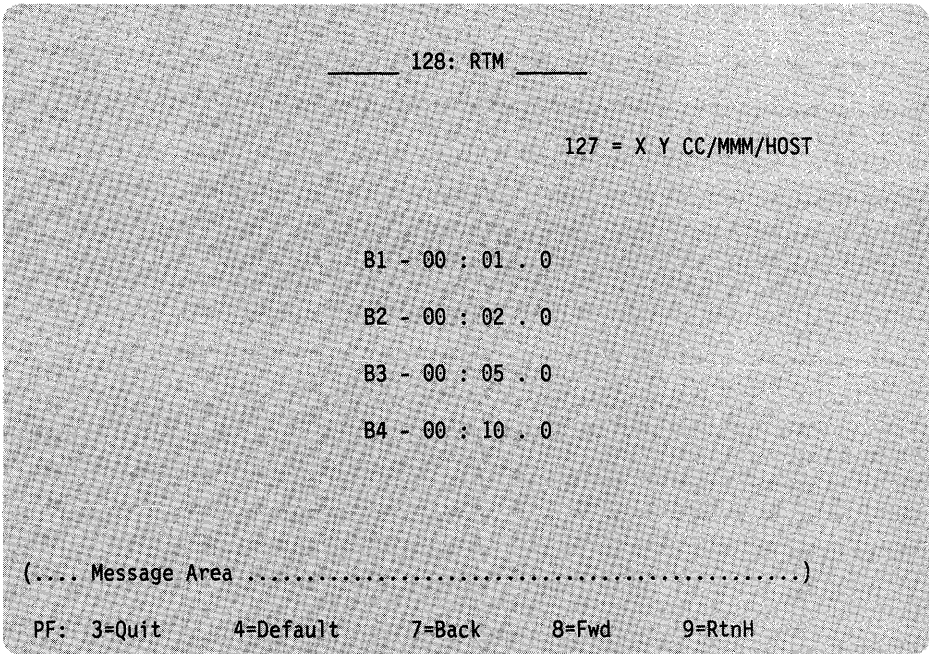

Figure 5-1. Version A of the 128 Panel

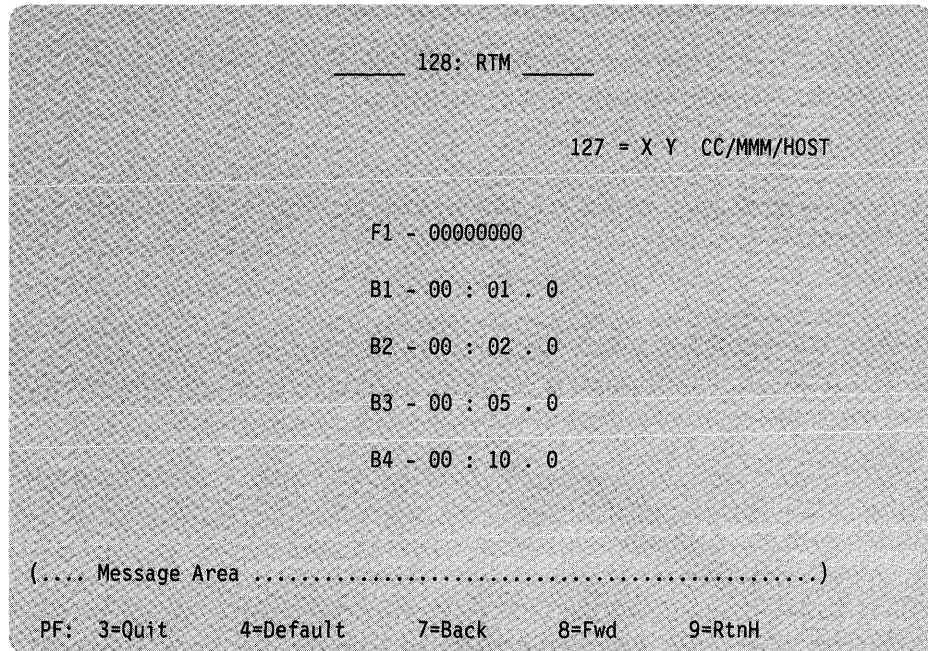

Figure 5-2. Version B of the 128 Panel

Each of the fields is described below.

- 127 = X Y** The response to question 127 is displayed here.
- CC/MMM/HOST** CC is the secondary station address. MMM is the 3174 model designation (for example, 01R). HOST is the method of host attachment (for instance, BSC, SDLC).
- F1** The host interface status, an eight-digit field, is displayed only when host support is specified. This field cannot contain blanks; specify a 0 instead.
- B1 – B4** These fields specify the boundary — the maximum time associated with each RTM counter. Time is specified in minutes, seconds, and tenths of a second; for example, 11:35.3 is 11 minutes, 35 and 3/10 seconds. See “Sample Boundary Specifications” on page 5-9 for examples that illustrate both valid and invalid boundary specifications. This field cannot contain blanks; specify a 0 instead.
- Message Area** Operator messages appear here. The messages, which begin with a four-digit code, inform you of the progress of your activities. If there is a problem, the message will explain it.
- PF Keys** The functions of the PF Keys are explained in Chapter 13 under “How to Configure the Control Disk” on page 13-10.

How Is Response Time Measured?

When you customize for RTM support, a series of five counters (see Figure 5-3) is allocated for each display or logical terminal.

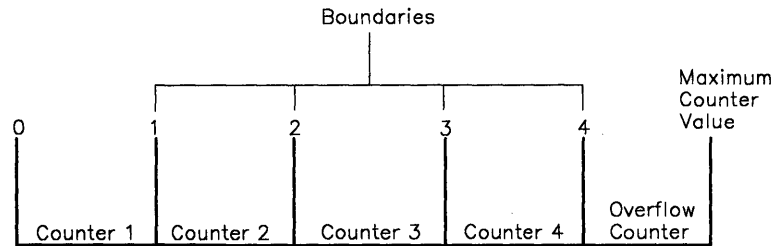

Figure 5-3. Counters and Boundaries

The counters represent the intervals of time into which response times can be categorized. You can set up as many as four counters and specify the maximum amount of time in the interval, or boundary, associated with each. If a response time is less than or equal to a particular boundary (for example, boundary 3), the counter associated with that boundary (counter 3) is incremented at the end of the transaction. If the response time does not fit within any of the boundaries, it is categorized in the fifth, or overflow, counter. If you specify any one of the first four boundaries as the maximum, the counter following that boundary becomes the overflow counter and the subsequent counters are ignored. The maximum counter value is 65535. The counter will not wrap around when this value is reached.

Sample Boundary Specifications

The following examples illustrate both valid and invalid specification of boundaries (B1, B2, B3, and B4).

Valid Boundaries

B1 - 00 : 02 . 1
 B2 - 00 : 03 . 2
 B3 - 00 : 05 . 5
 B4 - 00 : 07 . 7

Each response time of 2.1 seconds or less will increase the first counter.

Each response time exceeding 2.1 seconds but less than or equal to 3.2 seconds will increase the second counter.

Each response time exceeding 3.2 seconds but less than or equal to 5.5 seconds will increase the third counter.

Each response time exceeding 5.5 seconds but less than or equal to 7.7 seconds will increase the fourth counter.

Each response time exceeding 7.7 seconds will increase the fifth counter.

Invalid Boundaries

Example 1: Boundary Values Not in Ascending Order

B1 - 00 : 02 . 0
B2 - 00 : 05 . 7
B3 - 00 : 04 . 5
B4 - 00 : 06 . 8

Example 2: A Zero Entry for Field B1

B1 - 00 : 00 . 0
B2 - 00 : 00 . 1
B3 - 00 : 00 . 2
B4 - 00 : 00 . 3

Example 3: Nonzero Entry after the Maximum Boundary Value

B1 - 00 : 01 . 0
B2 - 27 : 18 . 3
B3 - 10 : 15 . 4
B4 - 20 : 10 . 5

Example 4: The Seconds Field Exceeds 59

B1 - 00 : 01 . 0
B2 - 00 : 10 . 0
B3 - 00 : 30 . 0
B4 - 00 : 61 . 0

Filling Out Worksheet 13—128: RTM

1. Locate “Worksheet 13—128: RTM” on page 20-15.
2. Enter your responses on the worksheet.
 - If you want to use the values that displayed in Figure 5-1 on page 5-7 or Figure 5-2 on page 5-8, circle “Default Values.” You have completed the worksheet.
Go to “What’s Next?” on page 5-12.
 - If your first digit response to question 127 was:
 - 1 or 2, circle “Version A.”
 - 3, 4, or 5, circle “Version B.”

3. Specify the boundaries (B1—B4) in Version A or B.

The rules for specifying boundaries are:

- Specify the time in minutes, seconds, and tenths of a second; for example, 11:35.3 is 11 minutes, 35 and 3/10 seconds.
- Do not specify a zero entry (00 : 00.0) for field B1.
- Specify from one to four boundaries, in sequence of ascending value. Do not embed a zero entry between two nonzero entries.
- The maximum boundary you can specify is 27 : 18.3. Any entries after the maximum value *must* be zero.
- The maximum entry you can specify in the seconds field is 59 seconds.

Version A is complete once you have specified the boundaries. For Version B, continue to the next step.

4. If you are completing Version B, fill out the eight-digit status flag field. Respond with 0 or 1:
 - 0 = No; turns off the function associated with the bit position.
 - 1 = Yes; turns on the function associated with the bit position.

Digit	Description
1	RTM Enabled. If the default (0) is used, RTM will remain off unless turned on by host support.
2	3174 transmits unsolicited RTM data when an UNBIND is processed (LU-LU)
3	3174 transmits unsolicited RTM data if counter overflows
4	3174 sends alert if counter overflows
5	Reserved. Set to 0.
6	Reserved. Set to 0.
7	Reserved. Set to 0.
8	Reserved. Set to 0.

Note: If you specify host support in question 127 but let the defaults (0) for the status flag field stand, RTM statistics will not be kept for any device unless a host application enables the RTM function.

Planner: You have completed “Worksheet 13—128: RTM.”

Return to the “Configuration and Reconfiguration Planning Procedure” and see step 4 on page 3-6 to determine if there are additional worksheets you need to fill out before going to the next step. You may also refer to the “3174 Quick-Reference Guide for Planners” to determine where to proceed next.

Keep records of your configuration by using one of the methods described in Chapter 2, “Keeping Records.”

Changing the RTM Specifications

If you have changes to make to the 128 panel, refer to the following table, which explains how to fill out the 128: RTM panel on the worksheet.

Change (127)	Result (128)
Your previous response to question 127 is unchanged.	Record the changed responses on the version (A or B) you previously used.
You changed the first digit of your response to question 127 from 1 to 2, or from 2 to 1.	Record the changed responses on Version A of the 128 panel.
You changed the first digit of your response to question 127 from 3, 4, or 5, to 1 or 2.	Fill out Version A of the 128 panel.
You changed the first digit of your response to question 127 from 1 or 2, to 3, 4, or 5.	Fill out Version B of the 128 panel.
The first digit of your response to question 127 was 3, 4, or 5, and, although changed, it is still 3, 4, or 5.	Record the changed responses on Version B of the 128 panel.

What’s Next?

Return to the “Configuration and Reconfiguration Planning Procedure,” and see step 4 on page 3-6 to determine if there are additional worksheets you need to fill out before going to the next step. You may also refer to the “3174 Quick-Reference Guide for Planners” to determine where to proceed next.

Chapter 6. Planning for X.25

Getting Ready to Plan for X.25	6-3
An Overview	6-3
332: X.25 Options	6-3
Filling In Worksheet 14—X.25 Options	6-5
400: Network Type	6-5
401: Circuit Type	6-5
402: Logical Channel Identifier	6-5
403: Logical Link Control	6-6
409: X.25 Keyboard Support Options	6-6
420: Incoming Call Options	6-7
421: Outgoing Call Options	6-9
423: Host DTE Address (HNAD)	6-10
424: 3174 DTE Address	6-10
430: Negotiated Packet Size (NPKT)	6-10
431: Packet Sequence Numbering	6-11
432: Negotiated Window Size (NWND)	6-11
433: K-Maximum Out	6-11
434: Nonstandard Default Packet Size (DPKT)	6-11
435: Nonstandard Default Window Size (DWND)	6-12
440: Throughput Class Negotiation (TCLS)	6-12
441: Closed User Group (CUG)	6-13
442: Recognized Private Operating Agency (RPOA)	6-13
450: Link Level Transmit Timeout	6-13
451: Number of Retries	6-14
452: Connection Identifier Password (CID)	6-14
Changing the X.25 Options	6-15
What's Next?	6-15

Getting Ready to Plan for X.25

The information in this chapter will help you to complete step 3 of the “Configuration and Reconfiguration Planning Procedure.” Step 3 is located on page 3-6.

Before you start, you will need the following:

- “Worksheet 14—X.25 Options” on page 20-16
- The X.25 network subscription.

An Overview

Customizing for X.25 involves defining the packet formats and control procedures for the exchange of packets between data terminal equipment (DTE) and data-circuit-terminating equipment (DCE). The control procedures include establishing and clearing of calls, data transfer, flow control, and error recovery.

An X.25 network subscription can include many different facilities. You will need a copy of your firm’s X.25 network subscription, detailing which facilities your subscription includes. The 3174 supports these facilities for switched virtual circuits (SVCs) and provides customizing questions for them:

- Closed User Group
- Connection Identifier
- Window Size
- Packet Size
- Recognized Private Operating Agency
- Reverse Charge
- Throughput Class.

An operator, however, can modify customized values for certain X.25 facilities during the Dial procedure. To allow the operator to change values during the Dial procedure, for question 409 you *must* set the sixth digit equal to 0 (“Dial Screen Display”).

332: X.25 Options

Figure 6-1 on page 6-4 shows the X.25 panel as it appears on the display screen, before you enter any responses. “Worksheet 14—X.25 Options” corresponds to this panel.

Planner: *If you filled out “Worksheet 3—X.25,” you need to fill out “Worksheet 14—X.25 Options.” The information starting on page 6-5 will help you fill out this worksheet.*

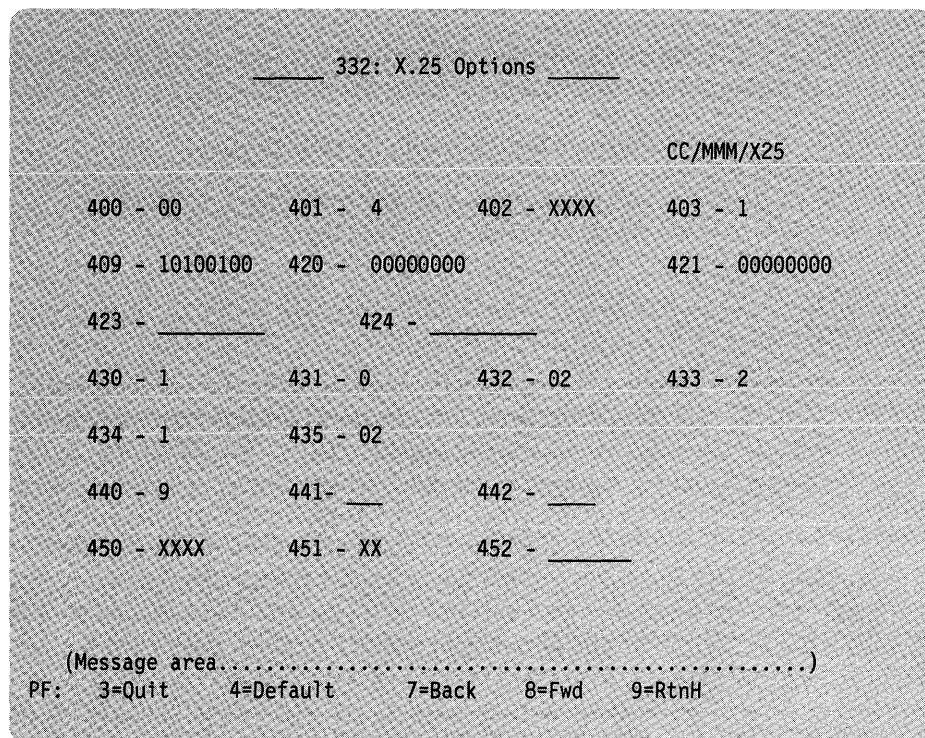

Figure 6-1. X.25 Options (332 Panel)

Each of the fields is described below.

- CC/MMM/X25** CC is the secondary station address. MMM is the 3174 model designation (for example, 01R).

- Default responses** The microcode will automatically supply the default response unless you specify a different response during customization. If there is a default value for a facility to which you do not subscribe, leave the default value unchanged.

- X** You must respond to this question. No default is supplied.

- Underscore** This question is a sequel to a previous question. Your response to the previous question dictates whether you need to respond to the sequel. For example, if your response to question 401 (circuit type) is 1 (permanent virtual circuit), no response is necessary for questions 423 and 424 (host and 3174 DTE address). When you do not want to specify a response on the 332: X.25 Options panel, circle the underscores. The person who customizes can leave the underscore unchanged in the response field.

- PF Keys** The functions of the PF keys are explained in Chapter 13 under "How to Configure the Control Disk."

Filling In Worksheet 14—X.25 Options

Locate "Worksheet 14—X.25 Options" on page 20-16. Write your responses to the following questions on the worksheet.

400: Network Type

Response:

- 00 = CCITT-recommended network with announced IBM support, not listed below.
- 01 = Connection is to the Netherlands DATANET 1.
- 02 = Connection is to United Kingdom Packet Switched Service (UKPSS)¹ or TELENET.²

The default response is 00.

This input field defines the network type supported. If IBM has announced X.25 support for your country's network and it is not one of the networks specified above, use the default (00).

401: Circuit Type

Response:

- 1 = Permanent virtual circuit (PVC)
- 2 = Incoming call (from host) only (SVC)
- 3 = Outgoing call (to host) only (SVC)
- 4 = Two-way call (SVC).

The default response is 4.

This input field indicates the type of circuit the 3174 will use. Refer to your subscription information for your response.

A permanent virtual circuit (PVC) gives users the appearance of an actual end-to-end connection, analogous to a point-to-point SDLC nonswitched connection. It requires no call setup or clearing by the DTE.

A switched virtual circuit (SVC) is a temporary logical connection between two DTEs, analogous to a point-to-point switched line.

402: Logical Channel Identifier

Response:

0000 – 4095.

This decimal value is the channel identifier for the circuit specified in question 401. Refer to your subscription information for your channel identifier.

Note: Some networks do not permit logical channel 0.

¹ Trademark of British Telecom

² Trademark of General Telephone and Electronics (GTE) Telenet Communications Corporation

403: Logical Link Control

Response:

- 0 = PSH control
- 1 = QLLC control.

The default response is 1.

This input field specifies the choice of protocols: physical service header (PSH) or qualified logical link control (QLLC). PSH support allows the 3174 to communicate with equipment attaching to the network via the Network Interface Adapter. IBM products with integrated X.25 support use QLLC.

409: X.25 Keyboard Support Options

Response: Eight digits (0 or 1).

- 0 = No
- 1 = Yes.

The default response is 10100100. Digits are numbered from left to right.

This field allows you to choose how to use X.25 Extension Mode keys. Keyboards on distributed function terminals cannot be used for initiating or terminating an X.25 communication. The X.25 keys are Extension, DIAL, LOCAL, COMM (Communicate), and DISC (Disconnect). For more information about the function of these keys, see the *3174 Functional Description, GA23-0218*.

Typically, the device attached to port 0 has access to all the X.25 Extension Mode keys. During customization, however, you can assign the keys to all ports, or certain keys can be deleted.

To allow the operator to change customized values for certain X.25 facilities on a per-call basis during the Dial procedure, set the sixth digit (Dial Screen Display) equal to 0.

Note: If the response to question 401 is 1, the first, second, and sixth digits have no meaning and are ignored.

Digit	Description
1	X.25 DISC Key
2	X.25 DISC Key
3	X.25 LOCAL and COMM
4	X.25 LOCAL and COMM
5	X.25 Keys
6	Dial Screen Display
7	Disconnect/Local Mode Operation
8	Reserved

Digits 1 and 2 - X.25 DISC Key:

- 00 = X.25 DISC key is not supported.
- 01 = X.25 DISC key is supported on port 0, regardless of how the fifth digit (X.25 Keys) is specified.
- 10 = Default – X.25 DISC is supported according to how the fifth digit (X.25 Keys) is specified.
- 11 = Invalid.

Digits 3 and 4 - X.25 LOCAL and COMM Keys:

- 00 = X.25 LOCAL and COMM keys are not supported.
- 01 = X.25 LOCAL and COMM keys are supported on port 0 regardless of how the fifth digit (X.25 Keys) is specified.
- 10 = Default – X.25 LOCAL and COMM keys are supported according to how the fifth digit (X.25 Keys) is specified.
- 11 = Invalid.

Digit 5 - X.25 Keys:

- 0 = Default – X.25 keys are supported on port 0 only.
- 1 = X.25 keys are supported on all ports (except those with a distributed function terminal attached).

Digit 6 - Dial Screen Display:

- 0 = Display all fields on the Dial screen. This allows the operator to change customized or default values on a per-call basis.
- 1 = Default – Display only the HNAD field on the Dial screen. This allows the operator to enter only the number to be called.

Digit 7 - Disconnect/Local Mode Operation:

- 0 = Default – If no SNA sessions are active, pressing the DISC (SVC) or LOCAL (PVC) key performs the disconnect or local mode operation. If any sessions are active, pressing the key once inhibits the rest of the keyboard. Pressing the key twice initiates the operation.
- 1 = The DISC (SVC) or LOCAL (PVC) key immediately performs the disconnect or local mode operation, regardless of active sessions.

Digit 8 - Reserved:

This digit is reserved and defaulted to 0.

420: Incoming Call Options

Response: Eight digits (0 or 1).

- 0 = No
- 1 = Yes.

The default response is 00000000. Digits are numbered from left to right.

Your response specifies how to process fields in an incoming call. Many of the choices refer to optional facilities; refer to your network subscription information before selecting your response.

If the X.25 keyboard support option (question 409) specifies that the Dial screen will display all the fields (sixth digit is 0), the operator can change any values selected for incoming call options during a Dial session on a per-call basis.

Digit	Description
1	Host DTE Address
2	Reverse-Charge Facility
3	Reverse-Charge Facility
4	Negotiated Packet Size Facility
5	Negotiated Window Size Facility
6	Connection Identifier
7	Throughput Class
8	Reserved

Digit 1 - Host DTE Address:

This digit specifies whether to validate the host (calling) DTE address on incoming calls.

Digits 2 and 3 - Reverse-Charge Facility:

These digits specify how to handle calls with the reverse-charge facility.

- 00 = Do not accept calls that include the reverse-charge facility.
- 01 = Accept calls with the reverse-charge facility equal to reverse charge requested.
- 10 = Accept calls with the reverse-charge facility *not* requested.
- 11 = Accept calls with the reverse-charge facility whether reverse charges are requested or not.

Digit 4 - Negotiated Packet Size Facility:

This digit specifies whether to accept Incoming Call packets that include the negotiated packet size facility.

Digit 5 - Negotiated Window Size Facility:

This digit specifies whether to accept Incoming Call packets that include the negotiated window size facility.

Digit 6 - Connection Identifier:

This digit specifies whether to validate the Connection Identifier (CID) on incoming calls.

Digit 7 - Throughput Class Negotiation:

This digit is for TCLS (Throughput Class Negotiation) and specifies whether to accept Incoming Call packets that include the Throughput Class facility.

Digit 8 - Reserved:

This digit is reserved and defaulted to 0.

421: Outgoing Call Options

Response: Eight digits (0 or 1).

- 0 = No
- 1 = Yes.

The default response is 00000000. Digits are numbered from left to right.

Your response specifies the fields to include in an outgoing Call Request packet. Many of the choices refer to optional facilities. Refer to your network subscription information before selecting your responses.

If the X.25 keyboard support option (question 409) specifies that the Dial screen display all fields (sixth digit is 0), an operator can change any values selected for outgoing call options during a Dial session on a per-call basis.

Digit	Description
1	3174 DTE Address
2	Reverse-Charge Facility
3	Reverse-Charge Facility
4	Negotiated Packet Size Facility
5	Negotiated Window Size Facility
6	Connection Identifier
7	Throughput Class
8	Reserved

Digit 1 - 3174 DTE Address:

This digit specifies whether to supply the 3174 (calling) DTE address in the Call Request packet.

Digits 2 and 3 - Reverse-Charge Facility:

These digits specify how to handle calls with the reverse-charge facility.

- 00 = Do not include the reverse-charge facility in the Call Request packet.
- 01 = Request reverse charge via the reverse-charge facility.
- 10 = Request *no* reverse charge via the reverse-charge facility.
- 11 = Invalid response.

Digit 4 - Negotiated Packet Size Facility:

The response for this digit specifies whether the negotiated packet size facility field will be included in the Call Request packet.

Digit 5 - Negotiated Window Size Facility:

This digit specifies whether to include the negotiated window size facility field in the Call Request packet.

Digit 6 - Connection Identifier:

This digit specifies whether to include the CID in the Call Request packet.

Digit 7 - Throughput Class:

This digit specifies whether to include the Throughput Class facility in the Call Request packet.

Digit 8 - Reserved:

This digit is reserved and is defaulted to 0.

423: Host DTE Address (HNAD)

Response: 0 through 9.

This field contains the host network data terminating equipment (DTE) address. Enter a maximum of 15 digits for the telephone number. You must respond to this question if:

- 401 = 2 and the first digit of the response to question 420 is 1, **or**
- 401 = 3, **or**
- 401 = 4.

Otherwise, circle the underscore (default) on the worksheet.

Note: If the response to this question does not fill the entire field, leave blanks or underscores wherever you have not written a numeric character.

424: 3174 DTE Address

Response: 0 through 9.

This field contains the local DTE address for the 3174. Enter a maximum of 15 digits for the telephone number. If the first digit of your response to question 421 is 1 and the response to question 401 is 3 or 4, then you must respond to this question. Otherwise, circle the underscore (default) on the worksheet.

Note: If the response to this question does not fill the entire field, leave blanks or underscores wherever you have not written a numeric character.

430: Negotiated Packet Size (NPKT)

Response:

- 0 = 64-byte packet
- 1 = 128-byte packet
- 2 = 256-byte packet
- 3 = 512-byte packet.

The default response is 1.

These responses define the negotiated packet size facility. This is an optional facility; refer to your subscription information. In question 420 (Incoming Call Options), if the fourth digit is 1, this field sets the size limit to which the 3174 may negotiate when accepting packets. In question 421 (Outgoing Call Options), if the fourth digit is 1, this field sets the requested size limit.

431: Packet Sequence Numbering*Response:*

- 0 = Modulo 8
- 1 = Modulo 128.

The default response is 0.

Your response determines whether the extended packet sequence numbering facility is to be used. Refer to your network subscription information for your response. The response to this question will affect your responses to questions 432 and 435.

432: Negotiated Window Size (NWND)*Response:*

- 01–07 = Range for modulo 8 (if question 431 equals 0)
- 01–11 = Range for modulo 128 (if question 431 equals 1).

This field is used for the negotiated window size facility. Refer to your network subscription for your response. In question 420 (Incoming Call Options), if the fifth digit is 1, this response sets the size limit to which the 3174 may negotiate when accepting packets. In question 421 (Outgoing Call Options), if the fifth digit is 1, this response sets the limit for the requested size.

433: K-Maximum Out*Response:* Maximum number of link level I-frames.

A value of 1–7.

The default response is 2.

This field specifies the maximum number of link level I-frames that the 3174 transmits before waiting for an acknowledgment. Your network subscription information will indicate the correct response.

434: Nonstandard Default Packet Size (DPKT)*Response:*

- 0 = 64-byte packet
- 1 = 128-byte packet
- 2 = 256-byte packet
- 3 = 512-byte packet.

The default response is 1.

Note: Although a packet size of 512 bytes can be specified to match the network, the 3174 imposes an upper data limit of 265 bytes for the path information unit (PIU) size.

This field contains the packet size value to which you subscribed in your X.25 network agreement. This value is used to select the 3174 packet size when any of the following conditions applies:

- In question 421 (Outgoing Call Options), the fourth digit is 0 (*not* to include the negotiated packet size facility in the outgoing call packet).
- An incoming call packet does *not* include the negotiated packet size facility.
- Permanent Virtual Circuit (PVC).

An operator can enter this value on a per-call basis, overriding default or customized values.

435: Nonstandard Default Window Size (DWND)

Response:

01 – 07 = Range for modulo 8 (if question 431 equals 0)

01 – 11 = Range for modulo 128 (if question 431 equals 1).

The default response is 02.

This field contains the packet window size value subscribed to in your X.25 network agreement. This value is used to select the 3174 window size when either of the following conditions applies:

- In question 421 (Outgoing Call Option), the fifth digit is 0 (*not* to include the window size facility in the outgoing call packet).
- An incoming call packet does *not* include the window size facility.

Refer to your network subscription for the value for this field.

440: Throughput Class Negotiation (TCLS)

Response:

3 = 75 bps

4 = 150 bps

5 = 300 bps

6 = 600 bps

7 = 1200 bps

8 = 2400 bps

9 = 4800 bps

A = 9600 bps

B = 19 200 bps

C = 48 000 bps.

The default response is 9.

Throughput Class is a network facility that sets priority for packets. Refer to your network subscription information for the response to this question.

In question 421 (Outgoing Call Options), if the seventh digit is 1 (include the Throughput Class facility in the Call Request packet), this field supplies the value. In question 420 (Incoming Call Options), if the seventh digit is 1 (accept Throughput Class on an incoming Call Request packet), the 3174 accepts the request value if it is less than or equal to the customized value. If not, the customized value is returned.

441: Closed User Group (CUG)*Response:*

00–99 = Include closed user group facility in outgoing Call Request packet.

A response to this question is optional.

Consult your network subscription information for your response. Enter a value to be included in the closed user group facility in an outgoing Call Request packet. If the field is left with underscores, blanks, or nulls, the closed user group facility is not included in the outgoing Call Request packet.

An operator can enter this value on a per-call basis, overriding default or customized values.

Note: If the response is a number with fewer than two digits, use a leading zero. For example, if your response is 6, enter 06 on the response form. If there is no response for this question, circle the underscore (default) on the worksheet.

442: Recognized Private Operating Agency (RPOA)*Response:*

0000–9999 = Recognized private operating agency.

A response to this question is optional. Enter a value for the recognized private operating agency facility if this applies to your system. If the field is left with underscores, this facility is not included in the outgoing Call Request packet.

An operator can enter this value on a per-call basis, overriding default or customized values.

Note: If the response is a number with fewer than four digits, use leading zeros. For example, if your response is 57, enter 0057 on the response form. If there is no response for this question, circle the underscore (default) on the worksheet.

450: Link Level Transmit Timeout*Response:* A value in the range 0001–2540.

You must respond to this question. No default is supplied.

This is the value referred to as T_1 or T_p . It is specified in 0.1-second intervals and set to the value required by each individual network. Refer to your network subscription for the value you should use. The 3174 timer will be $\pm 20\%$ of the value specified. For values greater than 25.0 seconds (0250 input), the lower (tenths) digit is ignored. For example, 0277 is treated as 27 seconds.

451: Number of Retries

Response: A value in the range 01–99.

You must respond to this question. No default is supplied.

Set this value (referred to as N_p or N_2) to the number of retries required by the individual network. Refer to your network subscription for this information.

452: Connection Identifier Password (CID)

Response: This 8-character password can have numeric characters (0–9), alphabetic characters (A–F), or blanks. If the response to this question does not fill the entire field, leave blanks or underscores wherever you have not written a hexadecimal character.

The connection identifier (CID) response is optional unless the sixth digit in questions 420 and 421 is 1. In question 420 (Incoming Call Options), if the sixth digit is 1 (validate the CID on incoming packets), this field is used for the validation. In question 421 (Outgoing Call Options), if the sixth digit is 1 (include the CID in the Call Request packet), this input field supplies the CID. If there is no response for this question, circle the underscore (default) on the worksheet.

Note: For 3174 customizing you must enter alphanumeric characters for this response. In the host SYSGEN procedure, however, you may be required to enter hexadecimal characters for this same CID password. (For example, hexadecimal characters are required for the NCP Packet Switching Interface [NPSI] SYSGEN.) Check the appropriate host documentation to determine SYSGEN requirements.

Planner: *You have completed “Worksheet 14—X.25 Options.”*

Return to the “Configuration and Reconfiguration Planning Procedure” and see step 3 on page 3-6 to determine if there are additional worksheets you need to fill out to complete this step. You may also refer to the “3174 Quick-Reference Guide for Planners” to determine where to proceed next.

Keep records of your configuration by using one of the methods described in Chapter 2.

Changing the X.25 Options

If you have changes to make to the X.25 Option panel, refer to the following table, which explains how to fill out the X.25 Options panel on the worksheet.

Change (101)	Result (332)
Your previous response was 101 = 3, and you did not change it.	The 332 panel that appears on the screen displays the previous responses. Enter your changed responses to the 332 panel on the worksheet.
You changed your previous response to 101 = 3.	<p>The panel that appears on the screen displays response fields filled with Xs, underscores, and default responses. See "Filling In Worksheet 14—X.25 Options" (on page 6-5) for instructions on filling out that panel on the configuration worksheet.</p> <p>If you have changes to make to a previously customized 332 panel, enter your changed responses on the 332: X.25 Options panel on the configuration worksheet. Reread the description of the question. Check whether the changed response requires you to change a response to another question.</p>

What's Next?

Return to the "Configuration and Reconfiguration Planning Procedure," and see step 3 on page 3-6 to determine if there are additional worksheets you need to fill out to complete this step. You may also refer to the "3174 Quick-Reference Guide for Planners" to determine where to proceed next.

Chapter 7. Planning for Central Site Change Management (CSCM)

Getting Ready to Plan Central Site Change Management	7-3
An Overview of CSCM	7-3
Filling In Worksheet 24—Common SNA	7-4
500: CSCM Unique	7-4
501: Network ID (NETID)	7-5
502: Logical Unit Name (LUNAME)	7-5
What's Next?	7-5

Getting Ready to Plan Central Site Change Management

This chapter consists of additional questions you need to respond to in order to customize your control unit if you plan to use Central Site Change Management (CSCM). If you do not plan to use CSCM, you may leave these questions set to their defaults. The information in this chapter will help you to complete step 3 of the "Configuration and Reconfiguration Planning Procedure." Step 3 is located on page 3-6.

Before you start, you will need "Worksheet 24—Common SNA" on page 20-26.

Note: Before planning for and answering the questions for Central Site Change Management (CSCM), you should become familiar with the *Central Site Customizing User's Guide*, GA23-0342.

An Overview of CSCM

CSCM offers many advantages over previous configurations. By centrally customizing the control units, you can reduce the errors that often occur during customization because one person and one location are doing the customizing for all the control units in the network. If you are using the NetView Distribution Manager (DM) software package, the customization data and/or microcode can be electronically distributed to the SNA Network Site Control Units and then remotely IMLed from the host. This decreases the need for trained personnel at each control unit.

If you plan to configure for CSCM, you will need to ensure that your control unit contains sufficient storage. The "Storage Planning Procedure" on page 3-7 will help you to determine your storage requirements. (Table 3-1 on page 3-9 contains the requirements for storage.) This procedure is performed during the second part of the planning process.

CSCM can be supported if you answered question 101: Host Attachment with one of the following host configurations:

- 2 = SDLC
- 3 = X.25
- 5 = Local SNA
- 6 = X.21
- 7 = Token-Ring Network.

If you answered question 101 with any of the above host configurations, the Common SNA panel will appear on your screen during the Configure procedure (see Figure 7-1 on page 7-4). "Worksheet 24—Common SNA" corresponds to this panel. On the panel and worksheet, you respond to the questions that are discussed in this chapter.

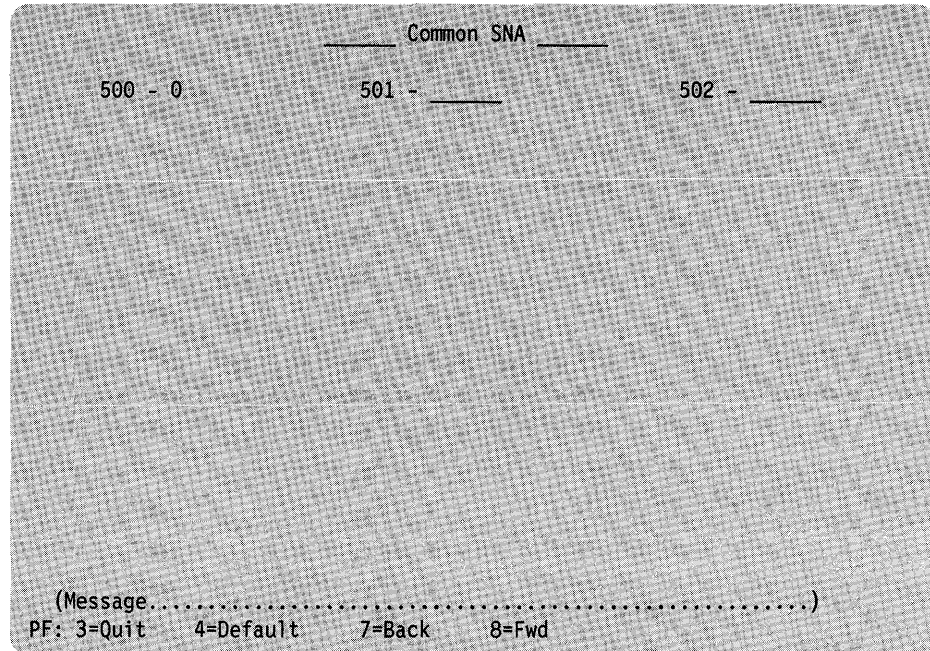

Figure 7-1. Common SNA panel displayed.

Filling In Worksheet 24—Common SNA

Planner: The following questions appear on “Worksheet 24—Common SNA.” This worksheet is filled out during step 3 of the “Configuration and Reconfiguration Planning Procedure.” Step 3 is located on page 3-6.

Locate “Worksheet 24—Common SNA” on page 20-26. Write your responses to the following questions on the worksheet.

500: CSCM Unique

Response:

- 0 = CSCM is not in use.
- 1 = CSCM is in use as a Network Site Control Unit.
- 2 = CSCM is in use as a Central Site Control Unit.

The default is 0.

Note: A response of 2 is not valid for the Token-Ring Gateway.

If you:

- Do not want to use CSCM, leave this question set to its default.
- Wish to use CSCM and the controller you are customizing for is a Network Site Control Unit, respond with a 1.
- Wish to use CSCM and the controller you are customizing for is the Central Site Control Unit (not supported on models 81R and 82R), respond with a 2.
- Respond to this question with a 1 or 2, you must respond to questions 501: Network ID and 502: LUNAME.

501: Network ID (NETID)

This name is used in a SNA network that is using the SNA Network Interconnection function. It identifies the controller you are customizing and distinguishes it from the other controllers in the network.

Response: Up to 8 alphanumeric characters (first character must be alphabetic and no blanks/spaces between characters are allowed). See the following example.

Example

```
NETCONTA (valid)
NW CONTA (invalid)
```

The default is blanks.

The name specified should be obtained from or coordinated with the Host System Programmer.

502: Logical Unit Name (LUNAME)

The LUNAME identifies a Control Unit that is using change management.

Response: Up to 8 alphanumeric characters (first character must be alphabetic and no blanks/spaces between characters are allowed). See the following example.

Example

```
NETWKLU6 (valid)
LU6 NETW (invalid)
```

The default is blanks.

The name specified should be obtained from or coordinated with the Host System Programmer.

What's Next?

You have completed "Worksheet 24—Common SNA."

Return to the "Configuration and Reconfiguration Planning Procedure," and see step 3 on page 3-6 to determine if there are additional worksheets that you need to fill out to complete this step. You may also refer to the "3174 Quick-Reference Guide for Planners" on page 2-9 to determine where to proceed next.

Chapter 8. Planning for the Asynchronous Emulation Adapter

Getting Ready to Plan for the Asynchronous Emulation Adapter	8-3
Terminology	8-3
Considerations	8-5
MLT	8-5
Storage	8-5
Overview	8-6
ASCII Display Stations Supported by the AEA	8-7
Filling Out Worksheet 16—3270 Attachment Diagram	8-8
Step 1. Fill In the Host Station Set Name and Station Set Number Columns	8-8
Step 2. Fill In the Station Type Column	8-9
Step 3. Fill In the Default Destination Columns	8-10
Step 4. Fill In the Station Set Name Column	8-12
Step 5. Fill In the Port Set Name Column	8-13
Filling Out Worksheet 17—ASCII Attachment Diagram	8-14
Step 1. Fill In the Host Station Set Name and Station Set Number Columns	8-14
Step 2. Fill In the Station Type Column	8-14
Step 3. Fill In the Default Destination Column	8-16
Step 4. Fill In the Port Type	8-18
Step 5. Fill In the Modem Type	8-20
Step 6. Fill In the Station Set Name Column	8-22
Step 7. Fill In the Port Set Name Column	8-24
Numbering the AEA Station Sets on the Attachment Diagrams	8-25
Filling Out the AEA Worksheets	8-27
Step 1. Fill Out Worksheet 18—AEA Configure	8-27
700: Configure the AEA Feature	8-27
701: Password for ASCII Display Stations on Switched Lines	8-27
Step 2. Fill Out Worksheet 19—AEA Port Set	8-27
Step 3. Fill Out Worksheet 20—AEA Port to Port Set Map	8-28
Step 4. Fill Out Worksheet 21—AEA Station Set	8-30
721: Station Set Name	8-32
722: Station Type	8-32
723: Port Set Name	8-33
725: Host Connection Menu Option	8-33
731: Flow Control Type	8-33
732: XON/XOFF Transmission Resumption Trigger	8-34
733: Line Speed	8-35
734: Line Speed (ASCII Host Upper Limit)	8-35
735: Parity	8-36
736: Stop Bits	8-36
737: Maximum Modem Line Speed	8-36
741: Switched Disconnect Timeout (3270 Hosts Only)	8-37
742: Inactivity Timeout	8-37
743: Prompt for Universal/Specific Keyboard Map	8-38
751: Data Stream Supported by the ASCII Host	8-38
752: ASCII Host Phone Number	8-38
761: Auto XON/XOFF (DEC VT100 Data Stream)	8-40
762: Wraparound Option (DEC VT100 Data Stream)	8-40
763: New Line Option (DEC VT100 Data Stream)	8-41
764: Margin Bell (DEC VT100 Data Stream)	8-41
771: Automatic Line Feed for Cursor Control (IBM 3101 Data Stream)	8-41
772: Carriage Return/Carriage Return—Line Feed Selection (IBM 3101 Data Stream)	8-42

773: Automatic New Line for Cursor Control (IBM 3101 Data Stream)	8-42
774: Scrolling (IBM 3101 Data Stream)	8-42
775: Line Turnaround Character (IBM 3101 Data Stream)	8-42
781: Attached Printer Prompt	8-42
782: Use of Form Feed	8-43
783: Page Length	8-43
Step 5. Fill Out Worksheet 22—AEA Default Destination	8-43
What's Next?	8-45

Getting Ready to Plan for the Asynchronous Emulation Adapter

The information in this chapter will help you complete step 5 of the “Configuration and Reconfiguration Planning Procedure.” Step 5 is located on page 3-6.

Before you start, you will need the following:

- The *Asynchronous Emulation Adapter: Introduction*, which you must read before planning to configure an AEA (Asynchronous Emulation Adapter). That book explains ASCII terminology, specifies requirements and restrictions that apply to ASCII configurations, and it gives detailed examples of possible configurations of ASCII hosts, display stations, and printers.
- The applicable worksheets in Chapter 20:
 - “Worksheet 16—3270 Attachment Diagram”
 - “Worksheet 17—ASCII Attachment Diagram”
 - “Worksheet 18—AEA Configure”
 - “Worksheet 19—AEA Port Set”
 - “Worksheet 20—AEA Port to Port Set Map”
 - “Worksheet 21—AEA Station Set”
 - “Worksheet 22—AEA Default Destination.”
- Documentation supporting the ASCII display stations, printers, and hosts you plan to use or attach (for example, ASCII display station and host setup or customizing records).

Note: To use the AEA, you need 3174 feature 3020 - AEA microcode on a DSL disk. You may need to plan for merging DSL code; see Chapter 14, “How to Merge DSL Code.”

Terminology

The following terms are used throughout this chapter.

Connection Menu

A list of all available host connections as defined by station names during customizing. The display station users may select alternate host connections from this list provided they have customized authorization.

AEA Terminal Type Menu

A list of all the available names and terminal types for the port you are currently connected to. Names and terminal types are taken from the station sets defined during customization.

Default Destination

A host to which a terminal or printer is connected when it is initially turned on. *If a host is not defined as the default destination for a display station, the Connection Menu is displayed.*

Note: A default destination is required for printers.

ASCII terminal emulation

The ability of a 3270 display station or printer to communicate with an ASCII host using the DEC¹ VT100 or IBM 3101 data stream.

3270 terminal emulation

The ability of an ASCII display station or printer to communicate with an IBM host using the 3270 data stream. *Supported displays are listed under "ASCII Display Stations Supported by the AEA" on page 8-7.*

AEA station

A 3270 or ASCII display station, printer, or host that is involved in asynchronous communication through the AEA.

AEA station set

One or more AEA stations with the same attributes, such as:

- Station type (for example, 3270 display station or DEC VT100 display station)
- Default destination (for example, the IBM 3270 host or an ASCII host)
- Flow control, line speed, parity, and various other attributes, described later in this chapter.

Station set names for host stations will appear on the connection menu for all devices with AEA access. Station set names for terminals will appear in the terminal type menu, provided that more than one station set is defined.

AEA port set

One or more control unit ports that have the same physical characteristics such as port type (switched, direct, nonswitched), speed, parity, and so on. A port set supports one or more station sets.

Note: Station sets supported by a port set must have different station types.

¹ Trademark of the Digital Equipment Corporation.

Considerations

You need to take into consideration Multiple Logical Terminals (MLT) and storage when configuring for the AEA. The following section discusses what should be considered.

MLT

MLT is a 3174 function that allows 3270 CUT display stations to access multiple host sessions; these sessions may be to a single IBM host, or to an IBM host and one or more ASCII hosts. Configuring the AEA to support the MLT function requires planning for special station and port set definitions and host access.

If MLT has been configured, 3270 display stations may have as many as five default destinations defined. The default destination configuration (the number and order of default destinations) is specified on a station-set basis; for each default destination configuration, you will need to define a station set and associated port set.

If you specify an ASCII host as a default destination, the host connection is established when the display station is turned on; an AEA port supporting that host is dedicated to the display station. In dedicating an AEA port supporting that host, access to that host for other display stations and printers will be limited to the remaining ports supporting that host.

For more information regarding the MLT function, see Chapter 3, "Planning to Configure" and Chapter 4, "Planning for Port Assignment."

Storage

The overall storage of the control unit must be sufficient to support the AEA and any other function that you may want configured. Under certain functional configurations, AEA will be deconfigured during IML if the control unit does not contain sufficient storage to support the AEA and any other functions you have configured.

The "Storage Planning Procedure" on page 3-7 will help you to determine the storage requirements for the AEA and any other functions you are planning to configure. (Table 3-1 on page 3-9 contains these storage requirements.) This procedure is performed in the second part of the planning process (after the configuration has been planned).

Overview

The Asynchronous Emulation Adapter (AEA) allows communication between:

- 3270 displays and/or printers to ASCII hosts
- ASCII displays and/or printers to IBM hosts
- ASCII displays and/or printers to ASCII hosts.

Information regarding planning your subsystem to allow communication with ASCII display stations, printers, and hosts can be found in the *3174 Asynchronous Emulation Adapter Introduction*. That book contains information necessary to coordinate all the planning tasks, including site planning and customizing planning.

Planning for customizing the 3174 Subsystem Control Unit to support the Asynchronous Emulation Adapter involves:

- Configuring for the AEA
- Specifying what default destinations display stations and printers will have
- Assigning display stations, printers, or hosts to groups called *station sets*
- Assigning station sets to *port sets* (a port or group of ports)
- Mapping (assigning) the ports supporting the station sets to the port sets.

The 3174 AEA configuration planning involves grouping devices and ports with similar attributes into sets. This process is used to reduce the amount of information that would normally have to be keyed in. For example, instead of keying in the information for each display station attached to the control unit, you key in the information *once* for a group of display stations with the same characteristics.

To group the devices and assign them to sets, you will need specific information about the display stations, printers, and hosts, and the ports they are attached to:

- What types they are (for example, 3270 or ASCII)
- What their characteristics are (for example, the line speed they require)
- Which ports they are attached to
- How they are attached to the control unit
- What host the printers will default to when they are turned on
- Whether the display stations will default to a specific host session or the Connection Menu when they are turned on (for 3270 display stations when the MLT function has been configured, you will also need to know what additional default destinations must be specified).

Using this information, you will be guided through two worksheets: "Worksheet 16—3270 Attachment Diagram" and "Worksheet 17—ASCII Attachment Diagram." You may have already received completed diagrams; if you have, you may proceed to "Numbering the AEA Station Sets on the Attachment Diagrams" on page 8-25.

You will use the two completed attachment diagrams to complete the AEA worksheets, which you will give to the person actually performing the customizing procedures.

The two diagrams are an important aid in planning the AEA configuration. The following pages will guide you through the attachment diagrams and the AEA worksheets and provide examples of how to fill them out.

ASCII Display Stations Supported by the AEA

The following list of ASCII display stations² are supported by the AEA:

- ADDS Viewpoint A2
- ADDS Viewpoint/78
- Hazeltine 1500
- Esprit Executive 10/78
- Hewlett-Packard 2621B
- IBM 3101
- IBM 3161
- IBM 3162
- IBM 3163
- IBM 3164
- Lear Siegler ADM 3A
Dumb Terminal
- Lear Siegler ADM 5
- Lear Siegler ADM 11
- Lear Siegler ADM 1178
- Lear Siegler ADM 12
- ANSI 3.64 terminal
- TeleVideo 912
- TeleVideo 970
- DEC VT52
- DEC VT100
- DEC VT241
- Personal Computers running
FTTERM (IBM File Transfer
Terminal Emulator Program).

Note: When ASCII display stations with attached printers are defined with unique port assignment entries, host applications can communicate with both at the same time through the same port.

Planner: The following procedures for filling out the Attachment Diagrams (3270 and ASCII) are the first step in planning for the AEA. The information on these Attachment Diagrams (when complete) will be used to fill out the remaining AEA worksheets.

² The list of display stations contains several trademarks. Viewpoint is a trademark of Applied Digital Data Systems, Inc. Hazeltine is a trademark of Hazeltine Corp. Esprit is a trademark of Esprit Systems, Inc. Hewlett-Packard is a trademark of the Hewlett-Packard Company. Lear Siegler is a trademark of Lear Siegler, Inc. ADM is a trademark of Lear Siegler, Inc. Dumb Terminal is a trademark of Lear Siegler, Inc. TeleVideo is a trademark of TeleVideo Systems, Inc.

Filling Out Worksheet 16—3270 Attachment Diagram

Locate and remove “Worksheet 16—3270 Attachment Diagram” on page 20-18. The following steps will guide you through the worksheet. **Read all these steps before filling out the worksheet.** Throughout these steps, an example configuration is provided. The example is designed to show a variety of connection possibilities and the resulting AEA configuration. The example configuration consists of:

- Hosts:
 - An IBM host named “VMSYS2”
 - Two ASCII hosts named “VAX VMS” and “PARTS”
- ASCII terminal emulation:
 - 3270 display stations accessing the IBM and ASCII hosts
 - 3270 printers accessing the IBM host
 - Use of the MLT function
- 3270 terminal emulation
 - IBM 3101 display stations accessing the IBM host
 - DEC VT100 display stations accessing the IBM host
 - Televideo 912 display stations accessing the IBM host.

The example has been designed to show a variety of connection possibilities and the resulting AEA configuration.

Step 1. Fill In the Host Station Set Name and Station Set Number Columns

In the response key on the top of the worksheet, fill in a name for each host you want your attached 3270 and ASCII display stations and printers to be able to access. See Figure 8-1.

	Station Set Name		Station Set Number
IBM Host =	VMSYS2	=	1
ASCII Host =	VAX VMS	=	2
ASCII Host =	PARTS	=	3
ASCII Host =		=	
ASCII Host =		=	
ASCII Host =		=	
ASCII Host =		=	
ASCII Host =		=	

Figure 8-1. The 3270 Response Key

The name may be up to 24 characters long, and up to 28 ASCII hosts may be defined as station sets. The IBM host has already been numbered *Station Set Number 1*. Number each additional host sequentially (for example, the next host would be *Station Set Number 2*). Use the back of the photocopied worksheet for additional ASCII hosts. **When naming the hosts, use easily recognized names as they will appear in the Connection Menu.** Figure 8-1 gives an example of how to fill in these columns.

Step 2. Fill In the Station Type Column

Refer to the completed site planning worksheets to determine what kind of device (a display station or printer) is attached to each of the control unit ports. Use the Station Type abbreviations listed in the response key to fill in the Station Type column for each port of the 3270 Terminal Adapter. The Station Type column is used to indicate whether a printer or a display station is attached to the control unit port. Figure 8-2 gives an example of how to fill in this column on the worksheet.

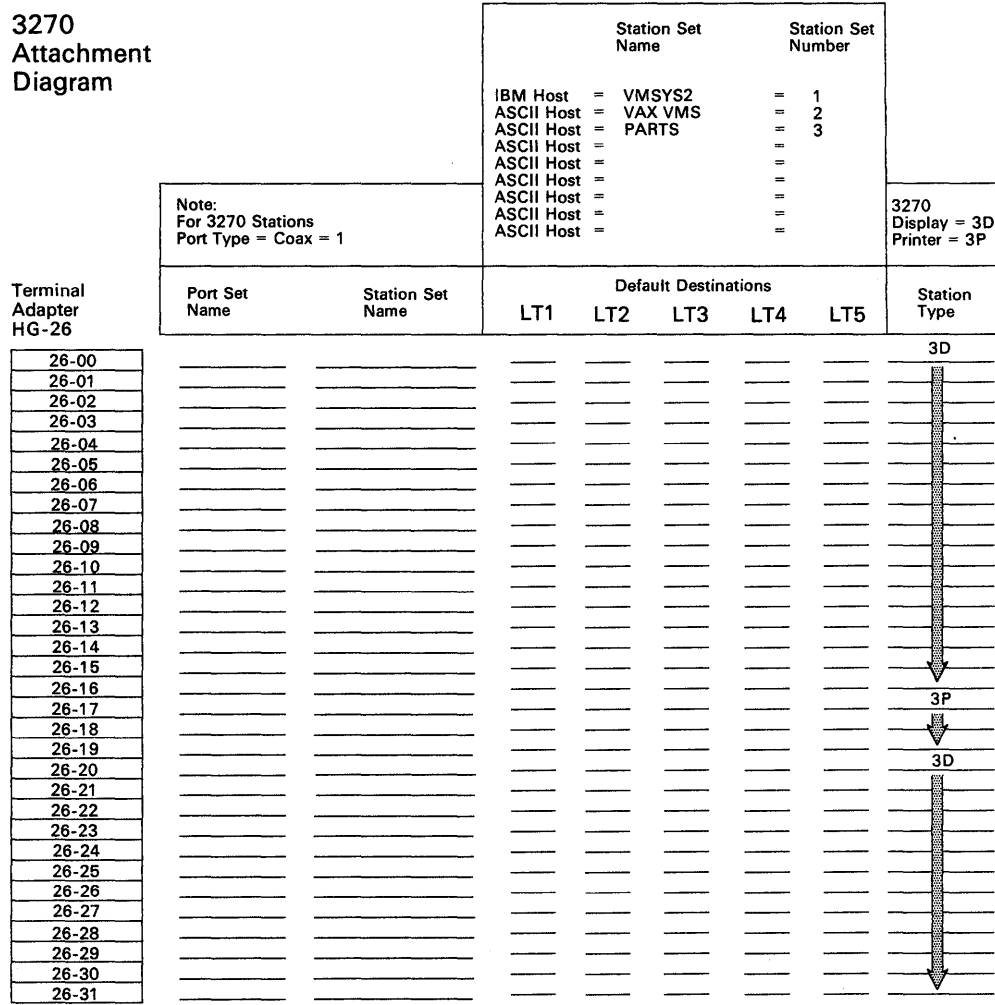

Figure 8-2. Filling In the Station Type Column on the 3270 Attachment Diagram

In Figure 8-2, ports 26-00 through 26-16 are all the same Station Type – 3D – which indicates they are 3270 display stations. Ports 26-17 through 26-19 are all Station Type 3P, which indicates they are 3270 printers. Ports 26-20 through 26-31 are Station Type 3D, which indicates they are 3270 display stations.

Step 3. Fill In the Default Destination Columns

The Default Destination columns are used to indicate the initial default destinations of the display stations and printers attached to the 3174 control unit. In the case of 3270 display stations (when MLT has been configured), they list the concurrent default destinations. For printers, you must specify a host. For display stations, you may or may not specify a host. *If you do not specify a host, write in CM for Connection Menu.*

"CM" indicates the 3270 display will have the Connection Menu displayed after powering on. When filling in the default destination panel during customization, you should leave the destination blank if the Connection Menu is to be the default. (CM is not a valid entry.)

If you specify an ASCII host as a default destination, the host connection is established when the display station or printer is initially turned on; an AEA port supporting that host is dedicated to the display station or printer. In dedicating an AEA port supporting an ASCII host, access to that host for other displays and printers will be limited to the remaining ports supporting the host. It is recommended that you specify an ASCII host as a default destination only if that ASCII host will be the sole host connection for the display station or printer. *CM* for Connection Menu should be indicated for all display stations that will require occasional access to ASCII hosts. If the connection menu is not the default destination, you will be able to display the connection menu on the display station by use of the connection menu key sequence.

Fill in Default Destination column 1 with either a host station set number (listed in the response key) to indicate a specific host session or *CM* to indicate the Connection Menu.

Fill in Default Destination columns 2 through 5 for display stations, only if MLT has been configured. Write in either a host station set number (from the response key) to indicate a specific host session or *CM* to indicate the Connection Menu for each concurrent default destination.

Note: If you have 3270 display stations with more than one default destination, it is recommended that you put IBM host sessions first, because of Port Assignment restrictions. See Chapter 4 if you need additional information regarding Port Assignment.

Figure 8-3 on page 8-11 gives an example of how to fill in the Default Destination columns on the 3270 Attachment Diagram.

3270
Attachment
Diagram

Terminal Adapter HG-26	Port Set Name	Station Set Name	Default Destinations					Station Type
			LT1	LT2	LT3	LT4	LT5	
			1	CM				3D
26-00			↓	↓				↓
26-01			↓	↓				↓
26-02			↓	↓				↓
26-03			↓	↓				↓
26-04			↓	↓				↓
26-05			↓	↓				↓
26-06			↓	↓				↓
26-07			↓	↓				↓
26-08			↓	↓				↓
26-09			↓	↓				↓
26-10			↓	↓				↓
26-11			↓	↓				↓
26-12			↓	↓				↓
26-13			↓	↓				↓
26-14			↓	↓				↓
26-15			↓	↓				↓
26-16			↓	↓				↓
			1					3P
26-17			↓					↓
26-18			↓					↓
26-19			↓					↓
			CM					3D
26-20			↓					↓
26-21			↓					↓
26-22			↓					↓
26-23			↓					↓
26-24			↓					↓
26-25			↓					↓
26-26			↓					↓
26-27			↓					↓
26-28			↓					↓
26-29			↓					↓
26-30			↓					↓
26-31			↓					↓

Figure 8-3. Filling In the Default Destination Columns

In Figure 8-3, display stations at ports 26-00 through 26-16 have been given the IBM host as their first default destination and then the Connection Menu. The printers on ports 26-17 through 26-19 have been given the IBM host as their default destination. The display stations on ports 26-20 through 26-31 have been given the Connection Menu.

Step 4. Fill In the Station Set Name Column

To fill in the Station Set Name column, sort the Station Types listed in the Station Type column into the two main types: printers and display stations. *The name may be up to 24 characters long.*

- Printers

Sort the printers into groups with the same default destination. Name each **group** and put the corresponding name in the Station Set Name column for each printer in the group.

- Display stations

Sort the display stations into groups with the same default destinations and in the same order. Name each **group** and put the corresponding name in the Station Set Name column for each display station in the group.

Figure 8-4 gives an example of how to group the 3270 stations into station sets.

Terminal Adapter HG-26	Port Set Name	Station Set Name	Default Destinations					Station Type
			LT1	LT2	LT3	LT4	LT5	
			1	CM				
26-00		3270 Displays 1	1	CM				3D
26-01								
26-02								
26-03								
26-04								
26-05								
26-06								
26-07								
26-08								
26-09								
26-10								
26-11								
26-12								
26-13								
26-14								
26-15								
26-16								
26-17		3270 Printers	1					3P
26-18								
26-19								
26-20		3270 Displays 2	CM					3D
26-21								
26-22								
26-23								
26-24								
26-25								
26-26								
26-27								
26-28								
26-29								
26-30								
26-31								

Figure 8-4. An Example of 3270 Station Sets

In Figure 8-4, display stations at ports 26-00 through 26-16 have been given the IBM host as their first default destination and then the Connection Menu. This group has been named **3270 Displays 1**. The printers attached to ports 26-17 through 26-19 have the IBM 3270 Host as their default destination. This group has

been named **3270 Printers**. The display stations on ports 26-20 through 26-31 have been given only the Connection Menu. This group has been named **3270 Displays 2**. The display stations have been grouped and assigned to two different station sets because one group has only one default destination and the other group has a default destination and the Connection Menu (two host sessions).

Step 5. Fill In the Port Set Name Column

The station sets you named can now be assigned to individual port sets.

Assign a port set name to each of the station sets and write the name in the Port Set Name column for the station set assigned to that port set. *The name may be up to 8 characters long.* Figure 8-5 gives an example of how to sort the station sets and assign them to port sets.

Terminal Adapter HG-26		Port Set Name	Station Set Name	Default Destinations					Station Type
				LT1	LT2	LT3	LT4	LT5	
26-00	3270D1	3270 Displays 1	1	CM				3D	
26-01									
26-02									
26-03									
26-04									
26-05									
26-06									
26-07									
26-08									
26-09									
26-10									
26-11									
26-12									
26-13									
26-14									
26-15									
26-16									
26-17	3270P	3270 Printers	1					3P	
26-18									
26-19									
26-20	3270D2	3270 Displays 2	CM					3D	
26-21									
26-22									
26-23									
26-24									
26-25									
26-26									
26-27									
26-28									
26-29									
26-30									
26-31									

Figure 8-5. An Example of 3270 Port Sets

In Figure 8-5, station set 3270 Displays 1 becomes a port set named **3270D1**. Station set 3270 Displays 2 becomes a port set named **3270D2**; this station set must be assigned to a different port set because it has only one default destination (host session). The station set **3270 Printers** has been assigned to port set 3270P.

Planner: You have completed the 3270 Attachment Diagram. Proceed to "Filling Out Worksheet 17—ASCII Attachment Diagram."

Filling Out Worksheet 17—ASCII Attachment Diagram

Locate and remove “Worksheet 17—ASCII Attachment Diagram” on page 20-19. The following steps will guide you through the worksheet.

Step 1. Fill In the Host Station Set Name and Station Set Number Columns

Copy the station set names and numbers listed in the response key of the 3270 Attachment Diagram into the response key for the ASCII Attachment Diagram (see Figure 8-6). *The name may be up to 24 characters long.* Figure 8-6 gives an example of how to fill in these columns.

	Station Set Name	Station Set Number
IBM Host =	VMSYS2	= 1
ASCII Host =	VAX VMS	= 2
ASCII Host =	PARTS	= 3
ASCII Host =		=
ASCII Host =		=
ASCII Host =		=
ASCII Host =		=
ASCII Host =		=
ASCII Host =		=

Figure 8-6. ASCII Response Key

In Figure 8-6, the IBM host has been named **VM SYS 2** and has been numbered **Station Set Number 1**. The two ASCII hosts have been named **VAX VMS** and **PARTS** and numbered **Station Set 2** and **Station Set 3**.

Step 2. Fill In the Station Type Column

Using the Station type abbreviations listed at the bottom of the worksheet, fill in the Station Type column for each port of the AEA.

Notes:

1. If several different Station Types will be attached through a modem pool that allows them to access a range of ports, list the Station Types for that range of ports in the Station Type column. A modem pool consists of one or more modems of the same type (for example, three Hayes modems) which are used by several display stations, printers, or hosts to access several control unit ports.
2. Be sure to fill in the Station Type column for any ASCII host(s) listed in the response key.

Figure 8-7 gives an example of how to fill in this column on the worksheets.

ASCII Attachment Diagram

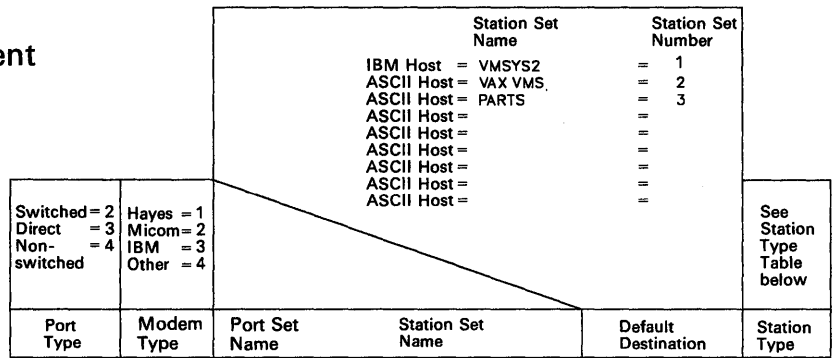

AEA HG-21

21-00
21-01
21-02
21-03
21-04
21-05
21-06
21-07

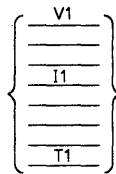

AEA HG-22

22-00
22-01
22-02
22-03
22-04
22-05
22-06
22-07

AH



AEA HG-23

23-00
23-01
23-02
23-03
23-04
23-05
23-06
23-07

Station Type Table

ASCII Host = AH	FTTERM (Color) = FC	Lear Siegler ADM 11/12 = L1	Televideo 912 = T1
ASCII Printer = AP	FTTERM (Monochrome) = FM	Lear Siegler ADM 3A/5 = L3	Televideo 970 = T7
ADD5 Viewpoint A-2 = A2	Hewlett Packard 2621 = H2	Lear Siegler 1178 = L7	DEC VT100 = V1
ADD5 Viewpoint 78 = A7	IBM 3101 = I1	ANSI 3.64 Terminal = S1	DEC VT241 = V2
Esprit Hazeltine 1500 = E1	IBM 3161/3163 = I3		DEC VT52 = V5
Esprit 78 = E7	IBM 3164 = I4		

Figure 8-7. Filling In the Station Type Column

In Figure 8-7, ports 21-00 through 21-07 have a variety of ASCII display stations, which will be accessing them through this range of ports. The responses listed at the bottom of the worksheet indicate that the **V1** indicates DEC VT100 display stations, the **I1** indicates IBM 3101 display stations, and the **T1** indicates TeleVideo 912 display stations. The ASCII host named **VAX VMS** will be using ports 22-00 through 22-04 to communicate and has been indicated with a station type of AH. The other ASCII host (named **PARTS**) will be using ports 22-05 through 22-07 and has also been indicated by an AH in the station type column.

Step 3. Fill In the Default Destination Column

The Default Destination Column is used to indicate a specific host session or the Connection Menu. The Station Type dictates whether a host or the Connection menu may be specified:

- For printers, a host must be specified.
- For display stations, you may or may not specify a host. *If you do not specify a host, write in CM.*
- For display stations with a printer, only the default destination for the display can be specified
- For Hosts, do not specify a default destination.

Fill in the Default Destination column for each printer and display station with either a host station set number (from the response key) or *CM* to indicate Connection Menu.

If you specify an ASCII host as a default destination, the host connection is established when the display station or printer is initially turned on; an AEA port supporting that host is dedicated to the display station or printer. In dedicating an AEA port supporting an ASCII host, access to that host for other display stations and printers will be limited to the remaining ports supporting the host. It is recommended that you specify an ASCII host as a default destination only if that ASCII host will be the sole host connection for the display station or printer. *CM* for Connection Menu should be indicated for all display stations that will require occasional access to ASCII hosts. Figure 8-8 on page 8-17 gives an example of how to fill in the Default Destination column on the ASCII Attachment Diagram.

ASCII Attachment Diagram

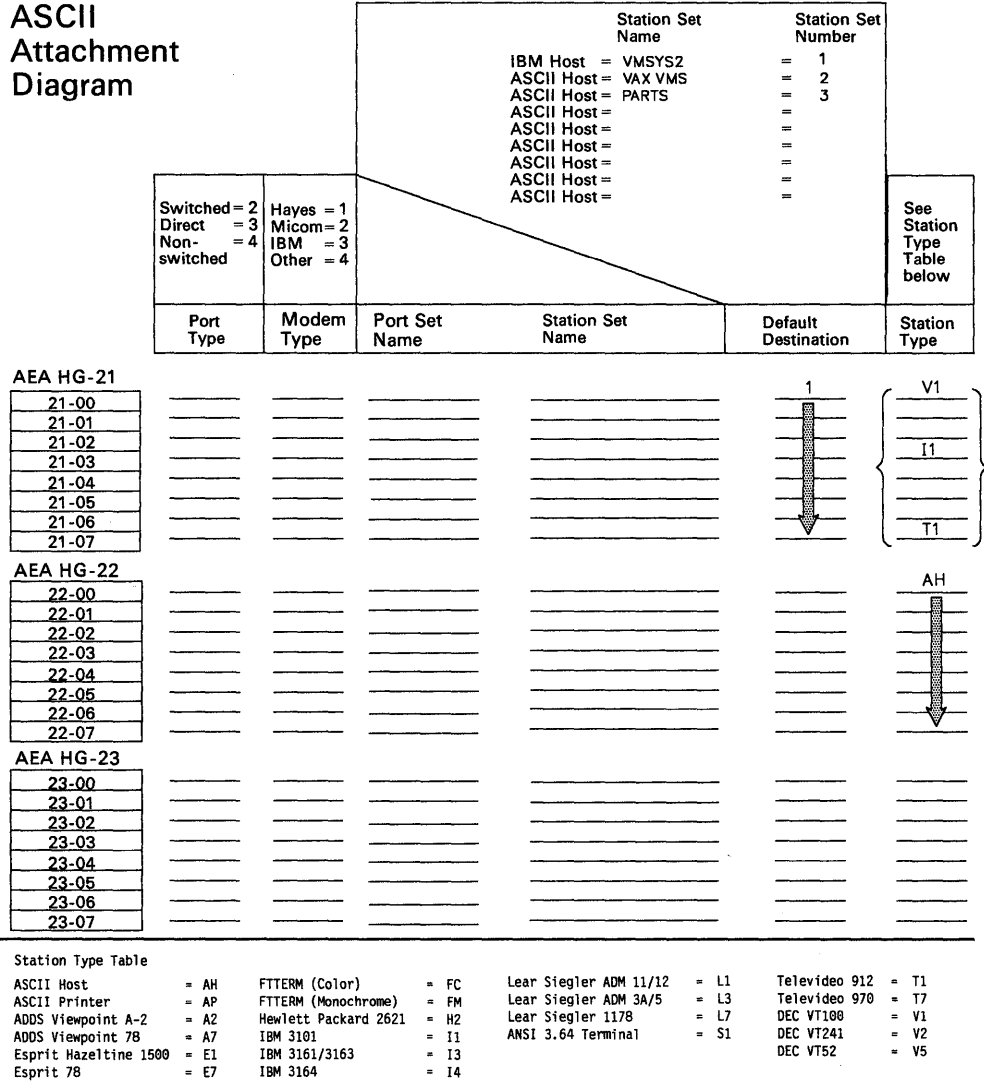

Figure 8-8. Filling In the Default Destination Column on the ASCII Attachment Diagram

In Figure 8-8, all the display stations in the range of ports (21-00 through 21-07) have been given the IBM Host as their default destination; the IBM Host has been indicated by 1, that being the number assigned to it in the response key.

Step 4. Fill In the Port Type

This column specifies what type of physical connection will be used to attach the display stations, printers, and hosts to the AEA ports.

Using the Port Type abbreviations listed in the response key, fill in the Port Type column for each of the AEA ports. The following list defines the three possible responses:

- 2 = Switched – Connection is made through modems attached to the Public Telephone network.
- 3 = Direct – Connection is made through null modems or by using a DTE cable.³
- 4 = Nonswitched – Connection is made through privately owned or leased lines or by using a DTE cable.

Figure 8-9 gives an example of how to fill in this column on the worksheets.

³ See the *Asynchronous Emulation Adapter Introduction*, GA23-0331, for information on null modems and DTE cables.

ASCII Attachment Diagram

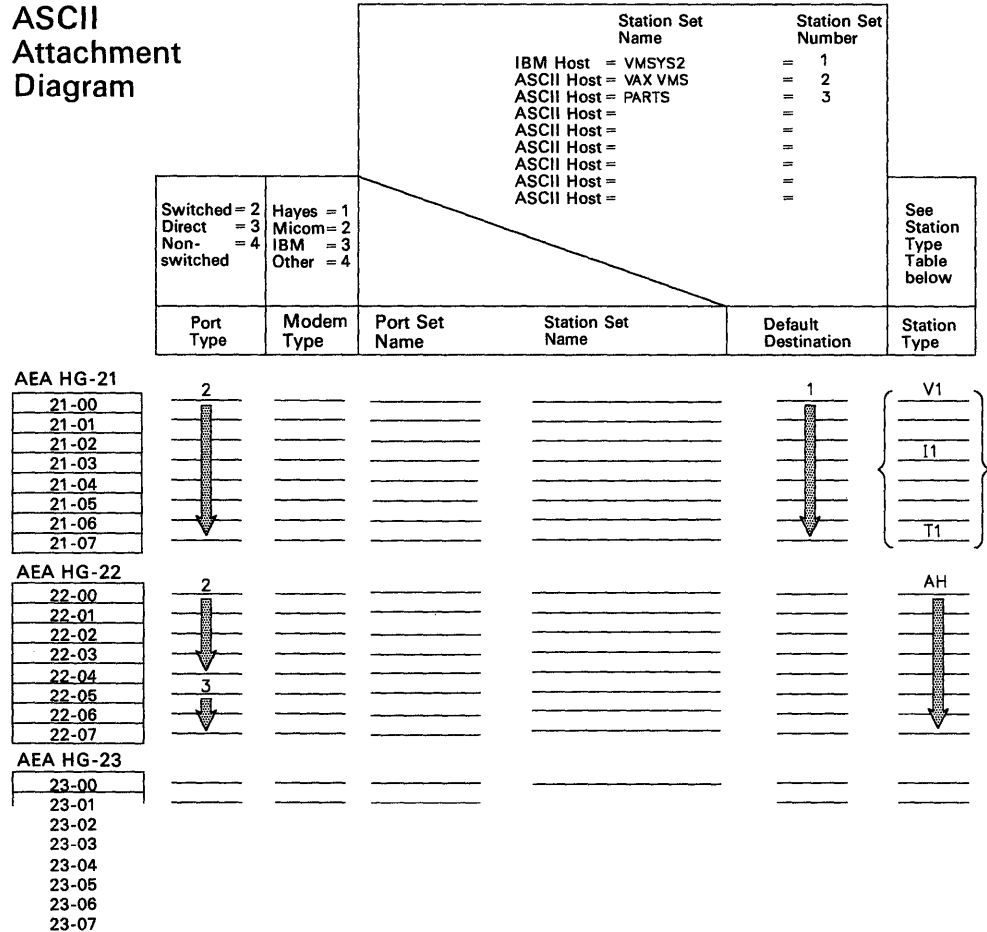

Station Type Table

ASCII Host = AH	FTTERM (Color) = FC	Lear Siegler ADM 11/12 = L1	Televideo 912 = T1
ASCII Printer = AP	FTTERM (Monochrome) = FM	Leaf Stegler ADM 3A/5 = L3	Televideo 978 = T7
ADD5 Viewpoint A-2 = A2	Hewlett Packard 2621 = H2	Lear Siegler 1178 = L7	DEC VT100 = V1
ADD5 Viewpoint 78 = A7	IBM 3101 = I1	ANSI 3.64 Terminal = S1	DEC VT241 = V2
Esprit Hazeltine 1500 = E1	IBM 3161/3163 = I3		DEC VT52 = V5
Esprit 78 = E7	IBM 3164 = I4		

Figure 8-9. Filling In the Port Type Column

In Figure 8-9, ports 21-00 through 21-07 all have the same Port Type – 2 – which indicates that the display stations are connected through switched lines. Ports 22-00 through 22-04 have a Port Type of 2, which indicates that this ASCII host is also connected through switched lines. Ports 22-05 through 22-07 have a port type of 3, which indicates that this ASCII host is connected through direct lines.

Step 5. Fill In the Modem Type

This column specifies what type of modem will be receiving and transmitting information for the display station, printer, or host on AEA ports using switched lines (having a port type of 2); the modem specified is the modem attached to the control unit.

Using the Modem Type abbreviations listed in the response key, fill in the Modem Type column for any AEA ports with a port type of 2. The following list defines the four possible responses:

- 1 = Hayes⁴ (or Hayes-compatible)
- 2 = Micom⁵ (or Micom-compatible)
- 3 = IBM
- 4 = Other (modems that meet the AEA specifications).

Figure 8-10 gives an example of how to fill in this column on the worksheets.

⁴ Trademark of Hayes Microcomputer Products, Inc.

⁵ Trademark of Micom Systems, Inc.

ASCII Attachment Diagram

		Station Set Name	Station Set Number		
		IBM Host = VMSYS2	= 1		
		ASCII Host = VAX VMS	= 2		
		ASCII Host = PARTS	= 3		
		ASCII Host =	=		
		ASCII Host =	=		
		ASCII Host =	=		
		ASCII Host =	=		
		ASCII Host =	=		
		ASCII Host =	=		
		ASCII Host =	=		
		ASCII Host =	=		
Switched = 2	Hayes = 1				
Direct = 3	Micom = 2				
Non-switched = 4	IBM = 3				
	Other = 4				
See Station Type Table below					
Port Type	Modem Type	Port Set Name	Station Set Name	Default Destination	Station Type

AEA HG-21

21-00
21-01
21-02
21-03
21-04
21-05
21-06
21-07

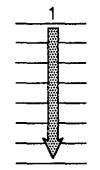
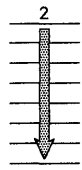

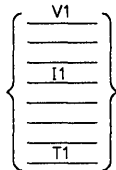
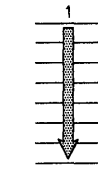

AEA HG-22

22-00
22-01
22-02
22-03
22-04
22-05
22-06
22-07

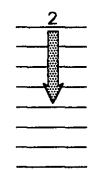
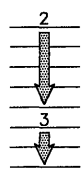

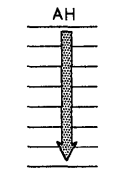
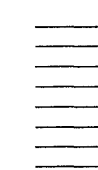

AEA HG-23

23-00
23-01
23-02
23-03
23-04
23-05
23-06
23-07

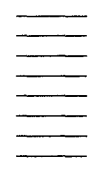
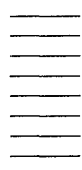

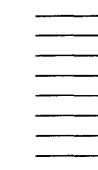

Station Type Table

ASCII Host = AH	FTTERM (Color) = FC	Lear Siegler ADM 11/12 = L1	Televideo 912 = T1
ASCII Printer = AP	FTTERM (Monochrome) = FM	Lear Siegler ADM 3A/5 = L3	Televideo 970 = T7
ADDS Viewpoint A-2 = A2	Hewlett Packard 2621 = H2	Lear Siegler 1178 = L7	DEC VT100 = V1
ADDS Viewpoint 78 = A7	IBM 3101 = I1	ANSI 3.64 Terminal = S1	DEC VT241 = V2
Esprit Hazeltine 1500 = E1	IBM 3161/3163 = I3		DEC VT52 = V5
Esprit 78 = E7	IBM 3164 = I4		

Figure 8-10. Filling In the Modem Type Column

In Figure 8-10, ports 21-00 through 21-07 have the same Modem Type – 1 – which indicates that these display stations all communicate using Hayes modems. Ports 22-00 through 22-04 have a modem type of 2, which indicates that this ASCII host communicates through Micom modems. The ASCII host on ports 22-05 through 22-07 has a port type of 3, which indicates that it is connected through direct lines and therefore does not use a modem.

Step 6. Fill In the Station Set Name Column

To fill in the AEA Station Set column, sort the station types listed in the Station Type column into three main types: hosts, printers, and display stations.

- **Hosts:**

Write the station set names for each AEA host (found in the response key) in the Station Set Name column of the AEA ports over which the host will communicate.

- **Printers:**

Sort the printers into groups that have the same port type, modem type, and default destination responses. Name each group and write the corresponding name in the Station Set Name column for each printer in the group.

- **Display stations:**

Sort the display stations into groups (station sets) that have the same station type, port type, modem type, and default destination responses. Name each group and write the corresponding name in the Station Set Name column for each display station in the group. **Use a name that the display station user can recognize.** If more than one AEA station set of different display stations is assigned to an AEA port set, the display station users will be prompted to identify their display station; the station set names assigned to that port set will be displayed and the display station user will select from the list.

The name can be up to 24 characters long. Figure 8-11 gives an example of how to sort the stations into station sets.

ASCII Attachment Diagram

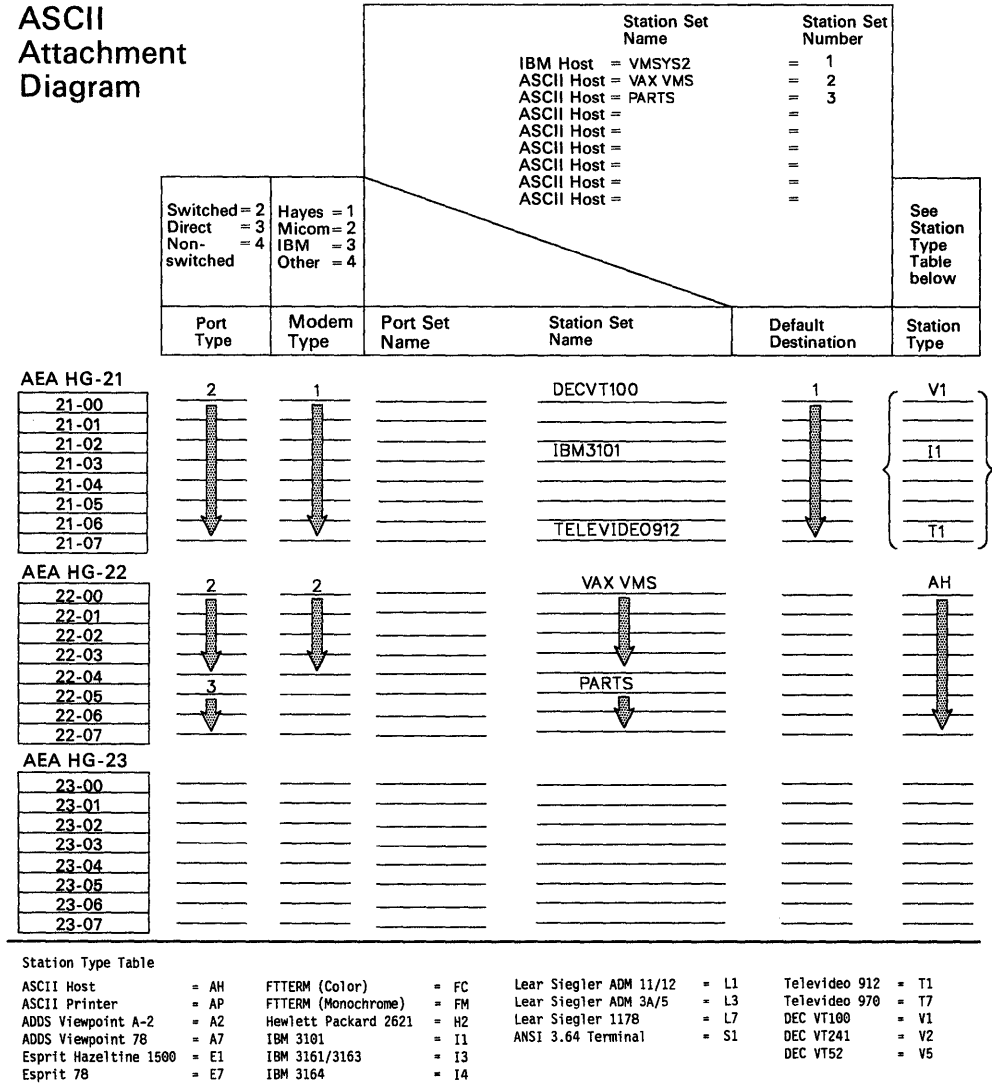

Figure 8-11. Filling In the AEA Station Set Name Column

In Figure 8-11, the display stations on the range of ports from 21-00 through 21-07 have the same port type, modem type, and default destination responses; they have been assigned to individual station sets because their station types differ. The display stations with station type V1 have been assigned to station set DECVT100; the display stations with station type I1 have been assigned to station set IBM3101, and the display stations with station type T1 have been assigned to station set TELEVIDEO912. The two ASCII hosts have already been named **VAX VMS** and **PARTS**, and the names have been written in the Station Set Name column.

Step 7. Fill In the Port Set Name Column

To fill in this column, sort the station sets into three groups: station sets made up of display stations, printers, and hosts.

- Station sets made up of display stations

Sort these station sets into groups that have the same port and modem types. Name each group and write the corresponding name in the Port Set Name column for each station set assigned to that port set. **If two or more station sets have the same station type, assign them to different port sets.**

- Station sets made up of printers

Assign each printer station set to an individual port set and name the port set. Write the corresponding name in the Port Set Name column for each station set.

- Station sets made up of hosts

Note: You can assign ASCII host station sets to a port set that contains a station set made up of display stations or printers if the port set and ASCII host station set have the same port and modem type.

Sort the host station sets into groups with the same port and modem type. Name each group and write the corresponding name in the Port Set Name column for each station set assigned to that port set.

A port set name can be up to 8 characters long. Figure 8-12 gives an example of how to sort the station sets and assign them to port sets.

ASCII Attachment Diagram

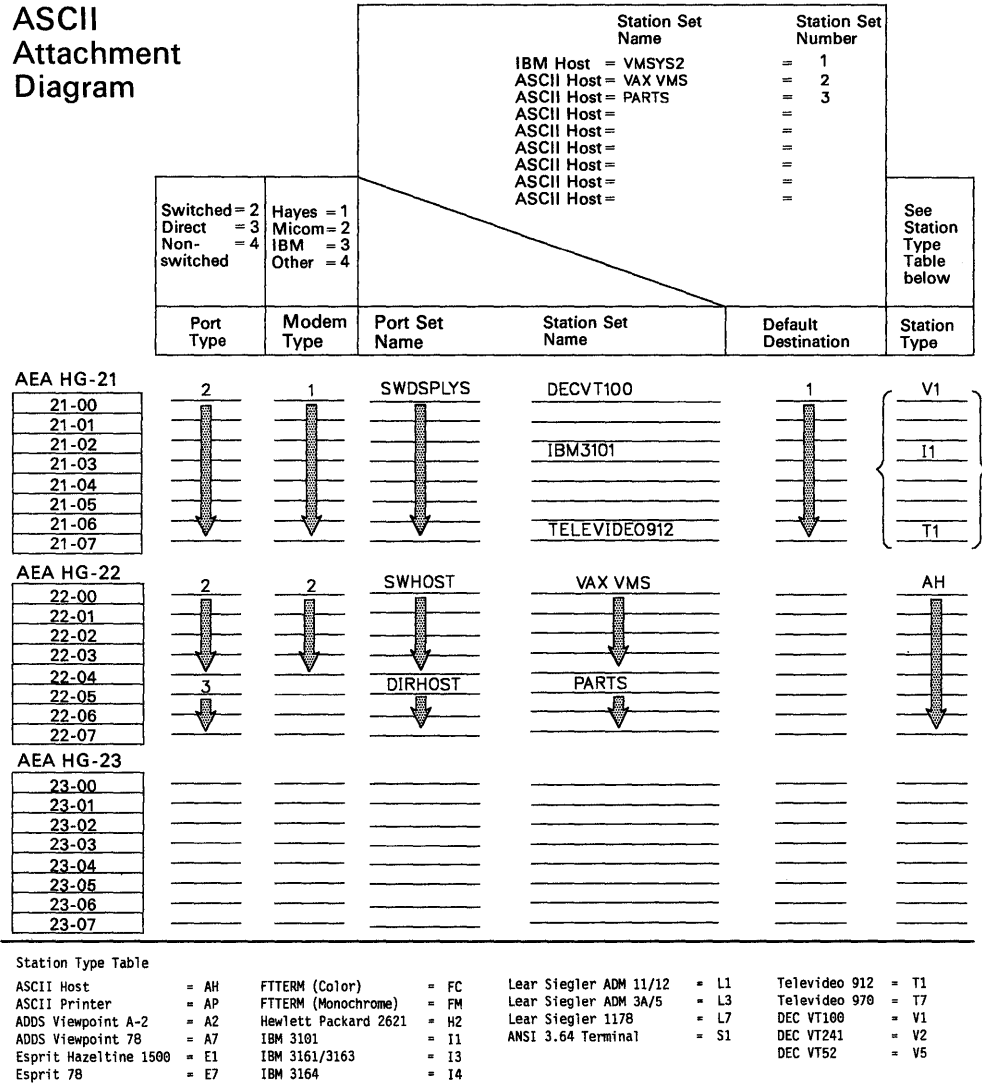

Figure 8-12. An Example of AEA Port Sets

In Figure 8-12, the station sets DECVT100, IBM3101, and TELEVIDEO912 can be assigned to the same port set because their station types are different and their port and modem types are the same; they have both been assigned to port set SWDSPLYS. The first ASCII host station set, named **VAX VMS**, cannot be assigned to the same port set as the second ASCII host station set, named **PARTS**, because their port types differ; station set VAX VMS has been assigned to port set SWHOST and station set PARTS has been assigned to port set DIRHOST.

Numbering the AEA Station Sets on the Attachment Diagrams

The host station sets have already been numbered in the response keys. Start numbering the station sets sequentially on the 3270 Attachment Diagram from the last number you assigned to a host in the response key. For example, if the last host was numbered 3, number the next station set 4. When you have completed numbering the station sets on the 3270 Attachment Diagram, number the station sets on the ASCII Attachment Diagram using the next sequential number.

Number each station set **once** and then write that number beside the station set name each time the name occurs. Figure 8-13 gives an example of how to number the station sets.

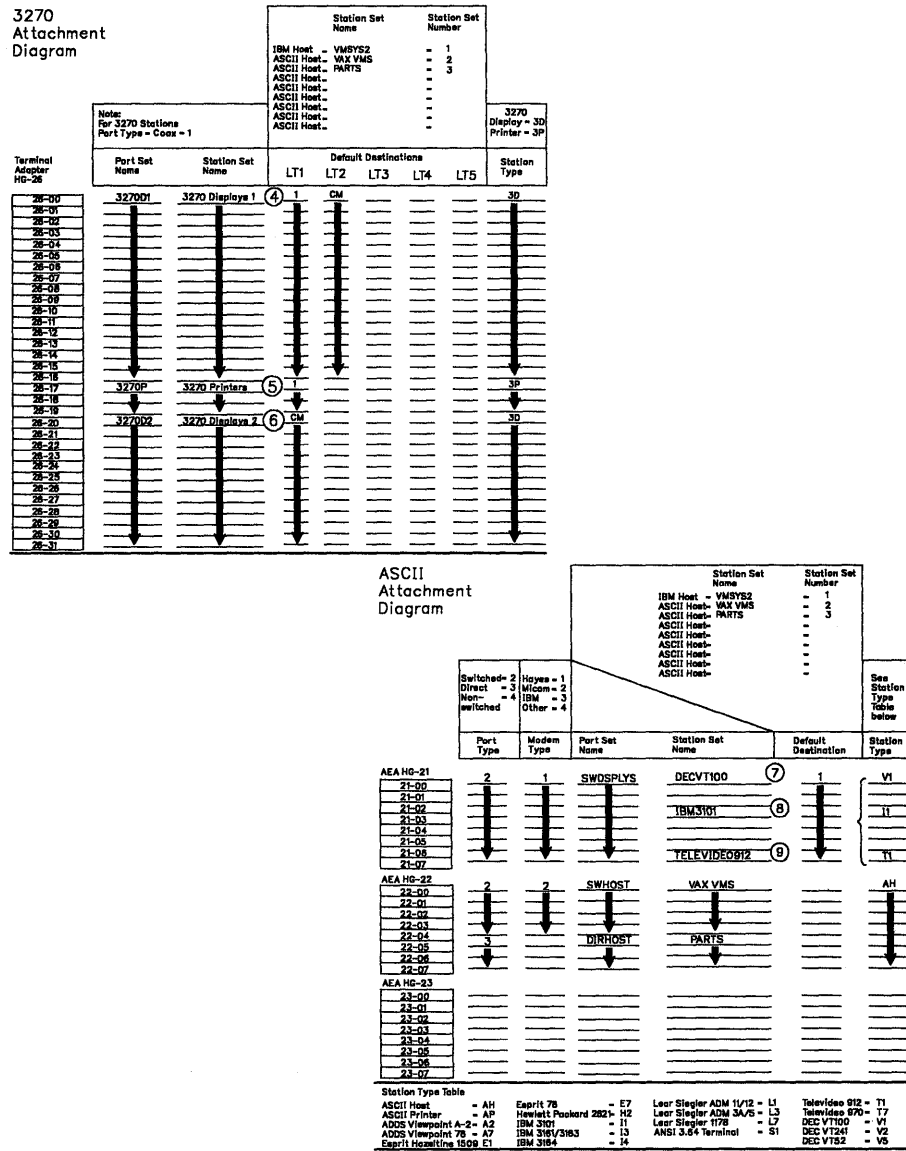

Figure 8-13. An Example of AEA Station Set Numbering

In Figure 8-13, the IBM 3270 Host and two ASCII hosts have been numbered 1, 2, and 3. The 3270 Attachment Diagram has already been completed, and three station sets have been numbered; station set **3270 Displays 1** has been numbered 4, station set **3270 Printers** has been numbered 5, and station set **3270 Displays 2** has been numbered 6. On the ASCII Attachment Diagram, the AEA station set **DECVT100** has been numbered 7, the station set **IBM3101** has been numbered 8, and the station set **TELEVIDEO912** has been numbered 9.

Planner: You have finished the first step in completing the remaining AEA worksheets. Use the two worksheets you just completed and the following information to fill out Worksheets 18 through 22. Remove Worksheets 18 through 22 from Chapter 20 and read "Filling Out the AEA Worksheets."

Filling Out the AEA Worksheets

Worksheets 18 through 22 are needed by the person customizing the 3174 control unit to support the AEA. It is recommended that you read all the following steps before filling out the worksheets.

Step 1. Fill Out Worksheet 18—AEA Configure

Following is a description of the two questions on the worksheet and the possible responses.

700: Configure the AEA Feature

Response:

- 0 = Turns off the AEA feature and maintains any AEA configuration data previously stored.
- 1 = Initiates Configure or Reconfigure procedure for the AEA feature and turns on the AEA.

The default response is 0.

701: Password for ASCII Display Stations on Switched Lines

Response: Up to 8 alphanumeric characters (no blanks/spaces allowed).

This field specifies a password for all ASCII display stations operating on switched lines.

No response is necessary; if none is given, however, the display station user is not prompted for a password.

Step 2. Fill Out Worksheet 19—AEA Port Set

Following is a list of the different response areas for the worksheet and information on where the responses can be found on the 3270 and ASCII Attachment Diagrams. *Fill in the response areas for each unique port set name.*

Response Area	Where to Find the Response
----------------------	-----------------------------------

Name	Port Set Name column of the worksheets.
-------------	---

Be sure to list all the port set names you wrote in on "Worksheet 16—3270 Attachment Diagram" and "Worksheet 17—ASCII Attachment Diagram." *A maximum of 16 is allowed.*

Session Limit	Total number of default destinations (and CMs) listed for the port sets on the 3270 Attachment Diagram. Put the number of default destinations for each port set beside the corresponding port set name on "Worksheet 19—AEA Port Set."
----------------------	---

If the number of host addresses is less than the session limit when questions 117 and 118 are being answered, those sessions without host addresses will not be permitted to access the 3270 (IBM host). Access to ASCII hosts will be permitted however. If the address defined for questions 117 and 118 exceeds the session limit number, those addresses will be unused by the controller since no device will have a session corresponding to those addresses.

Note: 3270 port sets can have one to five session limits. ASCII port sets can have only one session limit.

Port Type

Port Type column of the ASCII Attachment Diagram.

For 3270 port sets, respond with a 1.

- 1 = 3270 Port Set
- 2 = Switched – Connection is made through modems attached to the public telephone network.
- 3 = Direct – Connection is made through null modems.
- 4 = Nonswitched – Connection is made through privately owned or leased lines.

Note: For nonswitched ports, the AEA will assume the device is attached and will not recognize that the device is powered off.

Modem Type

Modem Type column of the ASCII Attachment Diagram.

For 3270 port sets, do not respond to this question.

- 1 = Hayes (or Hayes-compatible)
- 2 = Micom (or Micom-compatible)
- 3 = IBM
- 4 = Other (modems that meet the AEA specifications)

Note: Not all of the models made by Hayes, Micom, and IBM are supported. For the modem models and command sets that are supported, see the *Asynchronous Emulation Adapter Introduction*, GA23-0331.

Step 3. Fill Out Worksheet 20—AEA Port to Port Set Map

Refer to the 3270 and ASCII Attachment Diagrams and determine which control unit ports support each port set. On "Worksheet 20—AEA Port to Port Set Map," indicate these ports by writing the number of the port set in the corresponding response area for each control unit port. (The port sets are numbered on "Worksheet 19—AEA Port Set.") Figure 8-14 on page 8-29 gives an example of mapping (assigning) the control unit ports to the port sets.

_____ AEA Port Set _____

Name	Session Limit	Port Type	Modem Type
1 3270D1	2	1	-
2 3270P	1	1	-
3 3270D2	1	1	-
4 SWDSPLYS	-	2	1
5 SWHOST	-	2	2
6 DIRHOST	-	3	-

_____ AEA Port to Port Set Map _____

TA (HG = 26)	0	1	2	3	4	5	6	7
(0 - 7)	1	1	1	1	1	1	1	1
(8 -15)	1	1	1	1	1	1	1	1
(16-23)	1	2	2	2	3	3	3	3
(24-31)	3	3	3	3	3	3	3	3
	0	1	2	3	4	5	6	7
AEA 1 (HG = 21):	4	4	4	4	4	4	4	4
AEA 2 (HG = 22):	5	5	5	5	5	6	6	6
AEA 3 (HG = 23):	---	---	---	---	---	---	---	---

1 = 3270D1 2 = 3270P 3 = 3270D2 4 = SWDSPLYS
 5 = SWHOST 6 = DIRHOST

Figure 8-14. Example of Port to Port Set Mapping (Assignment)

In Figure 8-14, port set 1 is named **3270D1**, port set 2 is **3270P**, port set 3 is **3270D2**, port set 4 is **SWDSPLYS**, port set 5 is **SWHOST**, and port set 6 is **DIRHOST**. Using the numbers of the port sets, you **assign** the 3174 ports to the specific port sets.

Planning for the AEA

In the example:

- 3174 ports 26-00 through 26-16 have been assigned to port set 1 (3270D1).
- Ports 26-17 through 26-19 have been assigned to port set 2 (3270P).
- Ports 26-20 through 26-31 have been assigned to port set 3 (3270D2).
- Ports 21-00 through 21-07 have been assigned to port set 4 (SWDSPLYS).
- Ports 22-00 through 22-04 have been assigned to port set 5 (SWHOST).
- Ports 22-05 through 22-07 have been assigned to port set 6 (DIRHOST).

Step 4. Fill Out Worksheet 21—AEA Station Set

Each AEA Station Set Worksheet represents a single station set. Make copies of this worksheet, one worksheet for each station set. To fill out these worksheets, refer to the numbers you assigned each station set on the 3270 and ASCII Attachment Diagrams. The first station sets are the host station sets (numbered in the response key). **Station sets must have only one number assigned.**

Using the numbers assigned to each station set, write the number in the response area to the left of question 721 on the Station Set Worksheets. You will fill out the Station Set Worksheets in the order in which you numbered them.

Proceed to Table 8-1 on page 8-31. This table contains the questions applicable for each Station type. Beginning with station set 1 (the IBM host), answer the questions listed under 3270 host; the questions can be found immediately following the chart.

After you have completed all the AEA Station Set Worksheets, continue with “Step 5. Fill Out Worksheet 22—AEA Default Destination” on page 8-43.

Table 8-1 on page 8-31 lists the questions that must be answered for each type of display station, host, and printer. If a √ appears beneath the station type, answer that question. For example, answer questions 721, 722, and 723 for a station set made up of 3270 printers.

Table 8-1. AEA Station-Type-Specific Questions

Question	ASCII Stations				3270 Stations		
	Host	Display Station	Printer	Display Station with Printer	Host	Display Station	Printer
721 - Station Set Name	✓	✓	✓	✓	✓	✓	✓
722 - Station Type	✓	✓	✓	✓	✓	✓	✓
723 - Port Set name	✓	✓	✓	✓		✓	✓
725 - Host Connection Menu Option		✓		✓		✓	
731 - Flow Control	✓	✓	✓	✓			
732 - XON/XOFF Transmission Resumption Trigger	✓	✓	✓	✓			
733 - Line Speed	✓	✓	✓	✓			
734 - Line Speed (Host Upper Limit)	✓						
735 - Parity	✓	✓	✓	✓			
736 - Stop Bits	✓	✓	✓	✓			
737 - Maximum Modem Line Speed	✓	✓	✓	✓			
741 - Switched Disconnect Timeout							
742 - Inactivity Timeout	✓	✓	✓	✓			
743 - Prompt for Universal/Specific Keyboard Map		✓		✓			
751 - Data Stream Supported by the ASCII Host	✓						
752 - ASCII Host Phone Number	✓						
761 - Auto XON/XOFF (DEC VT100)	✓						
762 - Wraparound Option (DEC VT100)	✓						
763 - New Line Option (DEC VT100)	✓						
764 - Margin Bell Option (DEC VT100)	✓						
771 - Automatic Line Feed for Cursor Control (IBM 3101)	✓						
772 - Carriage Return/ Carriage Return—Line Feed Selection (IBM 3101)	✓						
773 - Automatic New Line for Cursor Control (IBM 3101)	✓						
774 - Scrolling (IBM 3101)	✓						
775 - Line Turnaround Character (IBM 3101)	✓						
781 - Shared Printer Prompt				✓			
782 - Use of Form Feed			✓	✓			
783 - Page Length			✓	✓			

721: Station Set Name

Response: Up to 24 alphanumeric characters (blanks are permitted).

Fill in this response area with the station set name from the Station Set Name column on the attachment diagram. This name represents a group of display stations, printers, or hosts with the same attributes. Use easily recognized names because they will appear in the Connection Menu.

When naming station sets made up of displays, use a name the display station users can recognize as representing their display stations. If more than one station set of different ASCII display stations is assigned to a port set, the display station users will be prompted to identify their display station; the station set names assigned to that port set will be displayed and the display station user will select from the list.

722: Station Type

Response:

Station Set Type	ASCII Respond With	3270 Respond With
Host	AH	3H
Printer	AP	3P
Display Station:		3D
ADDS Viewpoint A2	A2	
ADDS Viewpoint/78	A7	
Esprit Executive 10/78	E7	
Hazeltine 1500	E1	
FTTERM Color (IBM File Transfer/Terminal Emulator Program)	FC	
FTTERM Monochrome (IBM File Transfer/Terminal Emulator Program)	FM	
Hewlett-Packard 2621B	H2	
IBM 3101	I1	
IBM 3161, 3162, or 3163	I3	
IBM 3164	I4	
Lear Siegler ADM 11 or ADM 12	L1	
Lear Siegler ADM 3A or ADM 5	L3	
Lear Siegler ADM 1178	L7	
Reserved	R1	
Reserved	R2	
ANSI 3.64 terminal	S1	
TeleVideo 912	T1	
TeleVideo 970	T7	
DEC VT100	V1	
DEC VT241	V2	
DEC VT52	V5	

Fill in this response area with the station type listed for this station set in the Station Type column of the applicable attachment diagram.

723: Port Set Name

Response: Up to 8 alphanumeric characters (blanks permitted).

Fill in this response area with the port set name listed for this station set on the applicable attachment diagram.

This name represents the port set to which this station set has been assigned.

725: Host Connection Menu Option

Response:

- 0 = The display station users in this station set will not be allowed to select a host connection other than their defined Default Destination from the Host Connection Menu.
- 1 = The display station users in this station set will be allowed to select alternative host connections from the Host Connection Menu.

The default response is 1.

Planner: Use the following sources of input while gathering information needed to respond to the remaining questions:

- *Persons responsible for setting up ASCII hosts*
- *ASCII host, display station, and printer customizing records*
- *ASCII device-supporting documentation*
- *External data base documentation (for example, subscription information for remote ASCII data bases).*

See the AEA Introduction for an explanation of terminology.

731: Flow Control Type

Response:

- 0 = None
- 1 = XON/XOFF
- 2 = DTR (applicable only for nonswitched port types)
- 3 = CTS (applicable only for direct port types).

The default response is 1.

Your response specifies the type of flow control to be used between the control unit and the ASCII host, display station, or printer.

<i>If</i>	<i>Then</i>
0 = None	The AEA will not recognize or apply any type of flow control. If the input rate exceeds the AEA's ability to process data, overflow errors and disconnection will occur.
1 = XON/XOFF	The AEA will transmit and receive XON and XOFF for data flow control. The ASCII control code XOFF (hex 13) is used to halt data transmission. The ASCII code XON (hex 11) is used to allow data transmission to resume.
2 = DTR	When the AEA detects a drop of the signal on the Data Set Ready (DSR) lead, it will stop sending data. To stop data transmission from an attached device, the AEA will drop the signal on the Data Terminal Ready (DTR) lead, which is cabled to the attached device's DSR lead.
3 = CTS	When the AEA recognizes lead changes in Clear To Send (CTS), it will start or stop sending data. To start or stop data transmission from an attached device, the AEA will change the signal on the Request To Send (RTS) lead.

Note: The correct flow control is required; if an incorrect response is made to this question, overrun errors can result. The DTE cable wiring diagram in *Site Planning*, GA23-0213, must be followed exactly for DTR or CTS flow control to function properly.

Refer to the host, display station, or printer setup information for your response.

732: XON/XOFF Transmission Resumption Trigger

Response:

- 1 = Resume after any character is received.
- 2 = Resume only after XON is received.

The default response is 1.

If XON/XOFF is used, the response to this question indicates the signal the control unit must receive to resume transmitting after it has received XOFF. Your response specifies whether transmission will be resumed only after XON is received by the adapter, or after any character is sent to the adapter.

You should use the default, because this will preclude display station "hangups" caused by an accidental transmission of XOFF.

733: Line Speed

Response: 0 through 7.

0 = Autobaud/Autoparity	4 = 2400 bps
1 = 300 bps	5 = 4800 bps
2 = 600 bps	6 = 9600 bps
3 = 1200 bps	7 = 19 200 bps.

The default response is 0 and cannot be specified for a host or printer.

Autobaud/Autoparity (0), indicates the AEA will determine the speed and parity of the connecting terminal from the first three characters received. The user must type in CR.CR (carriage return, period, carriage return).

If you are answering this question for a host that supports a range of speeds (for example, 300 to 1200 bits per second), your response should be the lower limit (in this example, 300 bits per second).

If the line speed for the host is not a range, but a specific number (for example, 2400 bits per second), respond to this question and *skip* the next question, 734.

Note: If *Autobaud (0)* is not specified, all terminals assigned to the same port set must be set at the same speed. If the line speed specified is incorrect, response to transmissions may be absent or garbled.

734: Line Speed (ASCII Host Upper Limit)

Planner: This question applies only to ASCII hosts that support autobaud and have a range, as described in question 733. If you responded to question 733 with a specific speed (for example, 2400 bits per second), do not respond to question 734.

Response:

2 = 600 bps	5 = 4800 bps
3 = 1200 bps	6 = 9600 bps
4 = 2400 bps	7 = 19 200 bps.

There is no default response for this question.

This field specifies the host's upper-limit line speed.

Note: If the host supports autobaud and has a range, the response to this question is the upper limit of the range and must be greater than the response to question 733. Question 733 should **not** be answered as Autobaud (0) for ASCII hosts, but should indicate the lowest data rate supported by both the ASCII host and the AEA.

735: Parity

Response:

0 = Autobaud/Autoparity	3 = None
1 = Odd	4 = Space
2 = Even	5 = Mark.

The default response is 0 and applies only to display stations; it cannot be used for hosts or printers.

If Autobaud is specified in question 733, then Autoparity (0) must be specified here.

Note: If *Autobaud* (0) is not specified, all terminals assigned to the same port set must be set at the same speed.

Your response specifies the parity and is required for ASCII hosts and printers. (See the Glossary for a definition of *parity*.)

Space (4) should be specified for transmissions requiring 8 bits and no parity. If None (3) is specified, the AEA will only send 7 data bits with no parity.

Note: If the parity specified is incorrect, response to transmissions will be absent or garbled.

736: Stop Bits

Response:

1 = 1 stop bit
2 = 2 stop bits.

The default response is 1.

Your response specifies whether the ASCII characters sent or received require 1 or 2 stop bits.

Note: If the number of stop bits specified is incorrect, response to transmissions may be absent or garbled.

737: Maximum Modem Line Speed

Response:

1 = 300 bps	5 = 4800 bps
2 = 600 bps	6 = 9600 bps
3 = 1200 bps	7 = 19 200 bps.
4 = 2400 bps	

There is no default response for this question. A response must be given if you are using a Hayes or IBM modem on switched lines and responded to question 733 with a 0.

Hayes and IBM modem users: If *Autobaud* (0) is specified in question 733, the answer to question 737 will determine the speed that commands are transmitted to your modem. To get the full use of the modem, respond to this question with the highest speed the attached modem it is capable of supporting.

741: Switched Disconnect Timeout (3270 Hosts Only)

Planner: This question applies only to 3270 hosts using BSC or local non-SNA as an attachment method.

Response: A three-digit number ranging from 000 to 254, representing a number of minutes (use leading zeros).

The default response is 000.

This question provides additional security function in the event of disconnection of a switched-line ASCII terminal. The response to this question specifies how long (in minutes), after the disconnection, the AEA port associated with this address should be held unavailable to take advantage of a host session timeout security feature. Ask your IBM host system programmer for this response.

742: Inactivity Timeout

Response: Value from 000 to 254, representing a number of minutes (use leading zeros).

The default response is 015. A response of 0 indicates that the device may remain inactive for an indefinite period (no inactivity timeout set).

A nonzero response to this question defines the time an AEA port may remain idle before the connection is broken and the port made available to other users. The timer is reset when data is received from ASCII display stations or hosts. For printer connections, the timer is reset whenever data is sent to the printer.

In deciding what response to make to this question, consider relating time that a display station remains inactive to lost resource. Your response should be made considering the following:

- Line (phone) cost
- Importance of this station set's access
- Port value (access of other display stations).

This question decides the amount of time that will be allowed for a display station, printer, or host to remain idle before the connection is broken.

743: Prompt for Universal/Specific Keyboard Map

Response:

- 0 = Do not display prompt.
- 1 = Display prompt.

The default response is 1.

This question decides whether the terminal user will be prompted with a choice of using the specific map supporting the display station or a universal map that supports all the terminal types supported by the AEA. A response of 0 indicates the user will be using the specific keyboard map and will not be prompted for a choice.

The specific keyboard map takes advantage of keyboard nomenclature (for example, cursor movement keys) and is recommended if only a few different types of ASCII display stations are in use.

The universal keyboard map is constant for all ASCII display stations and is recommended if many different display stations will be used by the same display station user.

751: Data Stream Supported by the ASCII Host

Response:

- 1 = Host uses VT100 data stream.
- 2 = Host uses 3101 data stream.

There is no default for this question.

752: ASCII Host Phone Number

Planner: A response to this question is required if this host is the default destination of a printer and the Port Type is switched (a response of 2 on "Worksheet 17—ASCII Attachment Diagram" or "Worksheet 19—AEA Port Set").

Response: Up to 48 alphanumeric characters.

This field contains the phone number of the ASCII host. This number will be sent to an autodial modem when a connection to this host is requested. This phone number can contain control characters the modem uses to perform certain operations (for example, "wait for second dial tone").

Certain modem control characters that are not usually allowed during customizing have substitutes provided. Other control characters can be inserted into the dial string by coding the hexadecimal representation of the required ASCII character (for example, X'52' = R).

See Table 8-2 for the modem control characters that must be substituted for IBM or Hayes modems; see Table 8-3 for the modem control characters that must be substituted for Micom modems.

Notes:

1. If you are accessing a public data base, refer to your subscription information for your response.
2. Refer to the modem supporting documentation for information on the specific modem requirements and information on control characters.
3. If the Port Type for this station set has been defined as switched (2) and this number is **not** specified, the display station user will be required to send the dial digits to the modem from his display station keyboard (perform a manual dial operation).
4. ATD does not have to be entered. The controller automatically supplies the ATD when dialing the number for Hayes and IBM modems.

Table 8-2. IBM and Hayes Modem-Embedded Character Substitutions	
IBM and Hayes Embedded Character	3174 Customization Substitution
P	P
T	T
,	W

The control characters used by IBM and Hayes modems are as follows:

- , – Pause (usually to allow for second dial tone)
- P – Switch to pulse dialing
- T – Switch to tone dialing
- 0 through 9 – Numbers supported.

Table 8-3. Micom Modem-Embedded Character Substitutions	
Micom Embedded Character	3174 Customization Substitution
\$	P
&	T
K	K

The control characters used by Micom modems are as follows:

- \$ – Switch to pulse dialing
- & – Switch to tone dialing
- K – Wait for second dial tone
- 0 through 9 – Numbers supported.

The example on page 8-40 illustrates control character substitution. In the example, "WW" is used to generate ",", in the dial string. There is no substitute for the "R" in the dial string; therefore, the hexadecimal code "X52" is used to generate "R". The Hayes string shown in the example would become the following string:

T9,,P1234567R

Example

T9 WW P123 4567 X52

└───┬───┘

 The hexadecimal code (translates to the character R)

The substituted control characters (translates to the characters ,,)

Note: Spaces are not required between the characters.

761: Auto XON/XOFF (DEC VT100 Data Stream)

Planner: Questions 761 through 764 apply to ASCII host stations that use a DEC VT100 data stream. They define the VT100 setup options the host expects the VT100 to use.

Refer to DEC VT100 setup information and to supporting documentation for currently operating local VT100 display stations. The DEC VT100 host expects these options to have been set up on the terminals. You may also want to see the 3174 Terminal User's Reference for Expanded Functions, GA32-0332.

Response:

- 0 = Auto XON/XOFF disabled
- 1 = Auto XON/XOFF enabled.

The default response is 1.

This field specifies whether Auto XON/XOFF is activated.

762: Wraparound Option (DEC VT100 Data Stream)

Response:

- 0 = Wraparound option disabled
- 1 = Wraparound option enabled.

The default response is 1.

This field identifies whether the wraparound option is operational. If you leave this question set to its default (1), a new line will be generated when a character is typed after the cursor has reached the right margin.

763: New Line Option (DEC VT100 Data Stream)

Response:

- 0 = New line option disabled
- 1 = New line option enabled.

The default response is 1.

This field identifies whether carriage return alone, or both carriage return and line feed will occur.

If the new line option is enabled, pressing the Return key will result in a carriage return and line feed. The receipt of a line feed will also result in a carriage return and line feed.

764: Margin Bell (DEC VT100 Data Stream)

Response:

- 0 = Margin bell disabled
- 1 = Margin bell enabled.

The default response is 1.

This field identifies whether the margin bell is operational. If you leave this question set to its default (1), an audible alarm will be generated when the cursor reaches the 72nd position.

771: Automatic Line Feed for Cursor Control (IBM 3101 Data Stream)

Planner: Questions 771 through 775 apply to ASCII host stations that use the IBM 3101 data stream. They define the 3101 setup option that the host expects the 3101s to use.

Refer to the setup information for the currently functioning 3101 terminal and to the IBM 3101 Display Terminal Description, GA18-2033, for information to answer the following questions.

Response:

- 0 = Automatic line feed disabled
- 1 = Automatic line feed enabled.

The default response is 1.

This field identifies whether the automatic line feed is operational. If you leave this question set to its default (1), the receipt of a carriage return will result in a carriage return and line feed.

772: Carriage Return/Carriage Return—Line Feed Selection (IBM 3101 Data Stream)

Response:

- 0 = Carriage Return
- 1 = Carriage Return and Line Feed.

The default response is 1.

This field identifies whether carriage return alone, or both carriage return and line feed, will occur.

773: Automatic New Line for Cursor Control (IBM 3101 Data Stream)

Response:

- 0 = Automatic new line disabled
- 1 = Automatic new line enabled.

The default response is 1.

This field identifies whether the cursor will automatically move to the first character position on the next line after it reaches the 80th position.

774: Scrolling (IBM 3101 Data Stream)

Response:

- 0 = Scrolling disabled
- 1 = Scrolling enabled.

The default response is 1.

This field identifies whether scrolling will be supported for the display stations.

775: Line Turnaround Character (IBM 3101 Data Stream)

Response:

- 0 = EOT (end of transmission)
- 1 = CR (carriage return)
- 2 = XOFF (transmitter off)
- 3 = ETX (end of text).

The default response is 1.

This field identifies the line turnaround character.

781: Attached Printer Prompt

Response:

- 0 = No
- 1 = Yes.

The default response is 0.

Some ASCII displays allow for attachment of a printer. The printer can be managed by the AEA as a separate device on the same line. For instance, printing can be accomplished from the ASCII display or initiated from the host.

Notes:

1. Display stations with attached printers will not operate if you do not respond to question 781 with a 1.
2. If you have ASCII display stations with attached printers you must specify a nonzero response for question 110: Multiple Logical Terminals.

If you respond to this question with a 1 (Yes), the following prompt will appear at connection time.

```
DO YOU HAVE A PRINTER ATTACHED TO THIS TERMINAL?
(1=YES, 0=NO) =====> _
```

When the prompt appears, users of ASCII display stations with attached printers can decide whether or not to let the AEA manage the attached printer. System prints will be allowed to print on the attached printer if a second host address is assigned to the port and the user responds with yes to the prompt.

782: Use of Form Feed

Response:

- 0 = Printer does not support form feed.
- 1 = Printer supports form feed.

The default response is 0.

This field identifies whether a printer can perform a form feed.

783: Page Length

Response: Value from 001 to 255 (use leading zeros).

The default response is 066.

This field defines the page length for an attached printer. If the printer does not support form feed, this count will be used to emulate form feeds in 3270 data streams.

Step 5. Fill Out Worksheet 22—AEA Default Destination

The LT1 at the top of this worksheet corresponds to the Default Destination column on the ASCII Attachment Diagram and the Default Destination 1 column on the 3270 Attachment Diagram. LT2 through LT5 correspond to the Default Destination 2 through 5 columns on the 3270 Attachment Diagram.

The station set numbers on “Worksheet 22—AEA Default Destination” correspond to the station set numbers on the 3270 and ASCII Attachment Diagrams.

- ASCII Attachment Diagram

The default destination for each station set has already been specified on the ASCII Attachment Diagram.

Planning for the AEA

For each station set number found on the ASCII Attachment Diagram, write in the default destination for that station set number in the LT1 column of the AEA Default Destination Worksheet. If a CM (for Connection Menu) is indicated, leave the LT1 column blank for that station set number.

Note: The session limit for ASCII terminals and printers is always 1. For an ASCII display with an attached printer, the session limit is also 1 (the default destination applies only to the display). Only the default destination for the display can be defined.

- 3270 Attachment Diagram

The default destinations for each station set have already been specified in the Default Destination columns on the 3270 Attachment Diagram.

For each station set number found on the 3270 Attachment Diagram, write in the Default Destination column responses for that station set number in the LT1 through LT5 columns of the AEA Default Destination Worksheet. If a CM (for Connection Menu) is indicated for any default destination, leave the corresponding LT column on the AEA Default Destination Worksheet blank for that station set number.

See Figure 8-15 for an example of how to complete this worksheet.

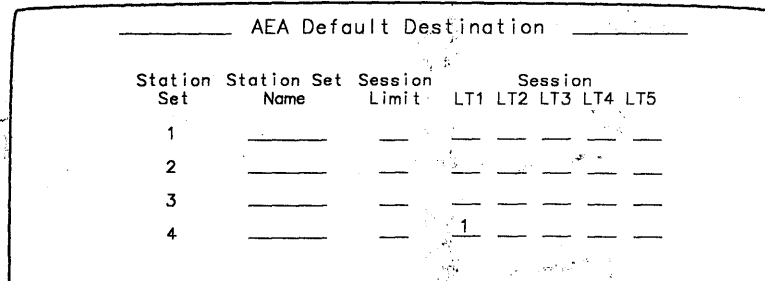
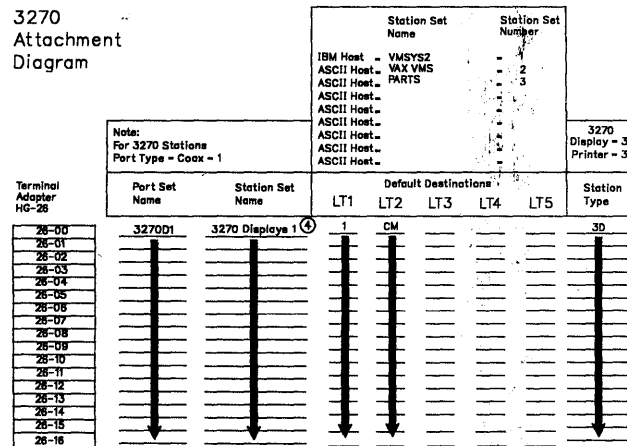

Figure 8-15. Example of the AEA Default Destination Worksheet

In Figure 8-15, the display stations in Station Set Number 4 have a 1 in the Default Destination 1 column and a CM in the Default Destination 2 column on the 3270 Attachment Diagram. On the AEA Default Destination Worksheet, beside Station Set 4, a 1 is written in the LT1 column and nothing is listed in the LT2 column; a blank represents the CM.

What's Next?

Return to the "Configuration and Reconfiguration Planning Procedure," and see step 5 on page 3-6 to determine if there are additional worksheets that you need to fill out to complete the planning process. You may also refer to the "3174 Quick-Reference Guide for Planners" to determine where to proceed next.

Chapter 9. Planning the Token-Ring Network 3270 Gateway

Getting Ready to Plan for the Token-Ring Network 3270 Gateway	9-3
Filling In the Token-Ring 3270 Gateway Worksheets	9-3
900: Token-Ring Network Address for the Gateway	9-3
905: Ring Error Monitor (REM)	9-3
908: Link Subsystem Name	9-4
940: Ring Address Assignment	9-4
941: Ring Transmission Definition	9-5
What's Next?	9-6

Getting Ready to Plan for the Token-Ring Network 3270 Gateway

This chapter consists of additional questions you need to respond to in order to customize your 3174 for the Token-Ring Network 3270 Gateway feature. The information in this chapter will help you to complete step 3 of the "Configuration and Reconfiguration Planning Procedure." Step 3 is located on page 3-6.

Before you start, you will need the Token-Ring Gateway, Ring Address Assignment, and Ring Transmission Definition Worksheets (Worksheets 9, 10, and 11), in Chapter 20.

Filling In the Token-Ring 3270 Gateway Worksheets

Planner: The following information will help you to complete the Token-Ring 3270 Gateway Worksheets (Worksheets 9, 10, and 11). These worksheets are filled out during step 3 of the "Configuration and Reconfiguration Planning Procedure." Step 3 is located on page 3-6.

Locate "Worksheet 9—Token-Ring Gateway" on page 20-11. Write your responses to the following questions on the worksheet.

900: Token-Ring Network Address for the Gateway

Response: Twelve-character hexadecimal address.

This address must be a locally administered address in the following format:

4000 XYYY YYYY

where X and Y are the user-assigned portion of the locally administered address. Note that X should not be greater than hex 7.

Note: The response for this question cannot be all zeros.

Ask your network planner for this address.

905: Ring Error Monitor (REM)

Response:

0 = No

1 = Yes.

The default response is 1.

For the ring that it is on, the ring error monitor (REM) performs integration and analysis of the nonrandom or error conditions on a real-time basis. REM then derives information indicating the fault domain (the two consecutive adapters and the media between them) most likely to be causing the failure, and provides this information to the host communications and systems management (C&SM) when error thresholds have been exceeded.

908: Link Subsystem Name

Response: Six alphanumeric nonblank characters.

The default response is IBMLAN, which appears on the panel.

The link subsystem name identifies which subsystem an alert is from when an alert is sent to the host.

940: Ring Address Assignment

Locate "Worksheet 10—Ring Address Assignment" on page 20-12. Fill in this worksheet using the following information.

The 940: Ring Address Assignment panel appears during the Configure procedure. "Worksheet 10—Ring Address Assignment" corresponds to this panel. Typing in the responses recorded on the worksheet while viewing this panel sets up the one-to-one correspondence between the subchannel addresses and the Token-Ring Network address of attaching products. Depending on the number of ring-attached SNA physical units, from one to five copies of this worksheet may need to be completed.

S@ Defines the addresses within the range of addresses defined in questions 104 and 105. This information is supplied automatically when the Ring Address Assignment panel is presented.

Ring@ This column defines the Token-Ring Network addresses of the ring-attached SNA physical units.

Response: Twelve-character hexadecimal address.

The address can be either a locally administered address or a universal address. A locally administered address is in the following format:

4000 XYYY YYYY

where X and Y are the user-assigned portion of the locally administered address. Note that X should not be greater than hex 7.

A universal address is in the following format:

WWWW WWZZ ZZZZ

where:

W = The ID of the adapter manufacturer (for example, IBM's ID is 1000 5A)

Z = The unique address portion of this adapter's universal address.

Note: See the publications for ring-attached products for addressing specifications.

The combination of the Ring@ and SAP@ address must be unique.

Important: When the product permits you to enter either type of address, the suggested choice is locally administered. If the universal address is used and the Token-Ring adapter is replaced, that product, as well as the gateway, will have to be recustomized with the new address.

SAP@ This column defines the service access point (SAP) ID. Some attaching products may appear as multiple SNA physical units and therefore have multiple SAP addresses and a single-ring address. See the publications for ring-attached products for more information.

Response: Two hexadecimal characters. The default is 04. This must be a multiple of 4 in the range of hex 04 to hex EC.

T This is the type of the device. The choices are:

- 0 for workstation
- 1 for 3174 control unit.

The default is 0. The selection will determine the default values for I-frame size and maximum out (transmit window size) on the Ring Transmission Definition panel.

Consult your network planner for this information.

941: Ring Transmission Definition

Locate “Worksheet 11—Ring Transmission Definition” on page 20-13. Fill in this worksheet using the following information.

The 941: Ring Transmission Definition panel appears during the Configure procedure. “Worksheet 11—Ring Transmission Definition” corresponds to this panel. Typing in the responses recorded on the worksheet while viewing this panel defines the transmit I-frame size and maximum-out for each ring-attached SNA physical unit. The defaults are listed below by Type selection.

Type	I-Frame	Maximum-Out
0 (workstation)	0 (265 bytes)	2
1 (control unit)	3 (2042 bytes)	2

Response: The F and W fields are the only unique fields between the 940 and 941 panels.

F = Transmit I-frame size. Valid entries for the maximum I-frame size are:

- 0 = 265 bytes
- 1 = 521 bytes
- 2 = 1033 bytes
- 3 = 2042 bytes.

Note: The values for the maximum I-frame size include the additional bytes for the SNA header.

W = Maximum-Out (transmit window size) – the number of transmits before waiting to receive an acknowledgment. See Table 9-1.

Consult your network planner for this information.

Note: If a 3174 Model 3R or 53R is attached to the ring, the responses to questions 380 and 381 on these control unit’s host-related worksheets (“Worksheet 8—Token-Ring Network” for each control unit) should match the F and W fields described here.

Table 9-1. Token-Ring Network Maximum Out (Planning for Gateway Feature)	
I-Frame Size Entered (F)	Maximum Window Size (W)
265	7
521	7
1033	4
2042	2

Relationship between Questions 381 and 941

Token-Ring Network performance is enhanced by the values assigned to the Transmit Window Size (question 941) and the Receive Window Size (question 381).

It is strongly recommended that you set 381 to 1. This ensures that each received frame is acknowledged. (Very little congestion is added to Token-Ring Network traffic by the acknowledgment.)

The W-field (Transmit Window Size) of question 941 should be set greater than 381. A value of 2 or 3 is recommended for single-ring Token-Ring Networks. If bridges are included, a value of 4 should be considered. These values will permit uninterrupted transmission by eliminating wait for acknowledgments and will keep buffer resources in the gateway from being depleted.

Never set the W-field response of 941 to less than question 381's response. This causes a wait for acknowledgments and, thus, degraded performance.

What's Next?

Return to the "Configuration and Reconfiguration Planning Procedure," and see step 3 on page 3-6 to determine if there are additional worksheets you need to fill out to complete this step. You may also refer to the "3174 Quick-Reference Guide for Planners" to determine where to proceed next.

Chapter 10. Planning to Define the Printer Authorization Matrix (PAM)

- Getting Ready to Plan the Printer Authorization Matrix 10-3
- Do You Need a Printer Authorization Matrix? 10-3
- A Sample PAM 10-7
- Filling Out Worksheet 15—Printer Authorization Matrix (PAM) 10-8
- What's Next? 10-8

Getting Ready to Plan the Printer Authorization Matrix

The information in this chapter will help you to complete step 5 of the “Configuration and Reconfiguration Planning Procedure.” Step 5 is located on page 3-6.

Before you start, you will need the following:

- “Worksheet 15—Printer Authorization Matrix (PAM)” on page 20-17
- Information about which printers are attached to which ports.

Note: If you have already planned for the Asynchronous Emulation Adapter (AEA), refer to the AEA Worksheets and Chapter 8, “Planning for the Asynchronous Emulation Adapter,” for information on AEA printer port assignments.

Do You Need a Printer Authorization Matrix?

The Printer Authorization Matrix (PAM) defines which printers the display stations in a cluster can use for local copy, host copy, and shared copy operations. A local copy transfers data directly from the display buffer to the printer buffer, and the data is printed. Printers that will not be used for local copy should not be entered in the matrix.

When you define the PAM, the capabilities of the local copy printer should match those of the source display, especially the capabilities for APL/Text handling and support of the Extended Highlighting, Color, and Programmed Symbols functions. If the print buffer is at least as large as the display buffer, a copy request can be serviced. However, if the other capabilities do not match, the printout may be degraded, depending on the contents of the display buffer when the copy request is serviced.

Figure 10-1 on page 10-4 is the PAM panel that appears on your screen during customization. “Worksheet 15—Printer Authorization Matrix (PAM)” corresponds to this panel.

Note: The size of the screen on the terminal used for customizing will determine how much information will be seen. For example, a 3278 Model 2 will show only 24 lines of information, while a 3278 Model 4 will display 43 lines of information.

For example, there are 10 of these panels on a Model 2 display. On the first panel of a Model 2 display, you can authorize as many as five printers for local copy. Should you want to authorize more than five printers in the cluster for local copy, advance to the next panel.

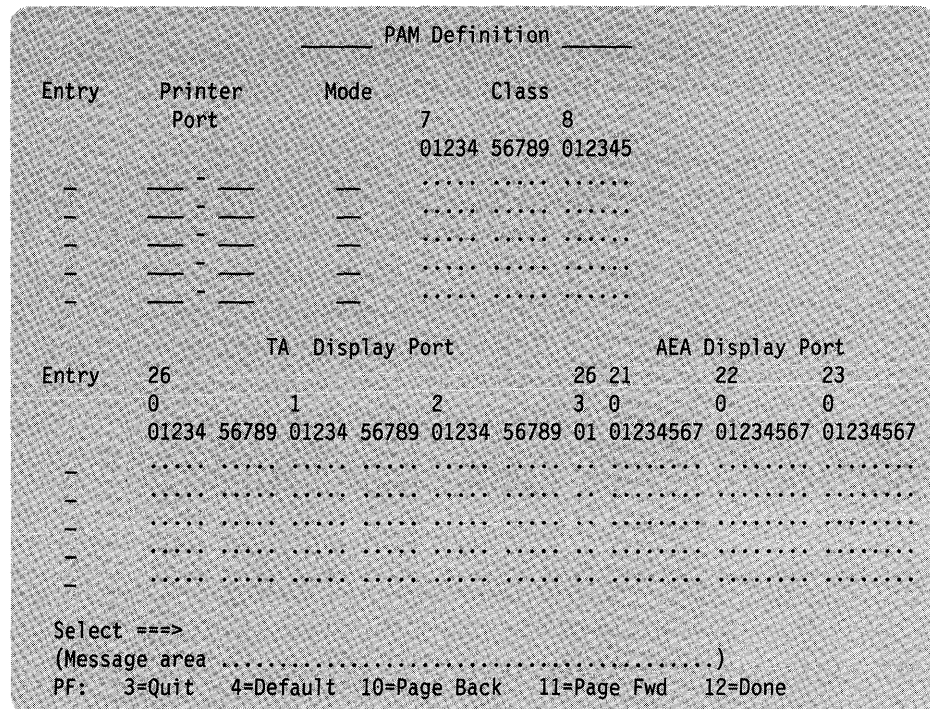

Figure 10-1. The Printer Authorization Matrix (PAM)

Each of the fields is described below.

Entry

The Printer Entry field displays a number to identify the printer that you assign for local copy. Printer Entry numbers may range from 1 to 47. You can assign the printers according to the maximum number permitted on each model of the 3174 and the possible combinations of AEA and 3270 printers allowed on each model, but the maximum number of *printers you can assign* is 47. See Table 10-1 below for the maximum number of 3270 and AEA printer port assignments for the different models of the 3174.

Table 10-1. Permitted Printer Assignment Combinations		
3174 Control Unit Models	Number of 3270 Printers	Number of AEA Printers
1L, 1R, 2R, and 3R	31	24 ¹
51R and 52R	15	8
53R, 81R, and 82R	7	0 ²

¹ Twenty-four ASCII printers is the maximum that can be assigned on the PAM; however, if 24 ASCII printers are assigned, only twenty-three 3270 printers can also be assigned; the total number of printer assignments permitted is 47.

²The 3174 Models 53R, 81R, and 82R do not support the Asynchronous Emulation Adapter (AEA).

The Printer Entry field appears twice on the panel. In the top half of the panel, next to the Entry number, you can define for each entry its Printer Port, Mode, and Class. In the bottom half of the panel, for the same Printer Entry, you identify the ports of the displays that will use the printer for local copy operations.

Printer Port

Write the port number for the printer. Remember to include the two-digit prefix: 26, 21, 22, or 23. You cannot assign a local copy printer to port 26-00.

Note: If you are customizing for individual port assignment, check to be sure that the assigned addresses on “Worksheet 12—117: Port Assignment” and the AEA Configure Worksheets (16 through 22) are consistent with the printer assignments defined here. The exception to this requirement is local copy printers; they do not require that a host address be assigned during port assignment. See “How to Configure the AEA” on page 13-56 for more information on the AEA Configure procedure.

Mode

In this field you define the mode in which the printer will operate:

- 0 = System
- 1 = Local
- 2 = Shared.

A printer in **system mode** is under host (system) control. Since host control is the default mode for each printer if no matrix is defined, it is unnecessary to include a printer on the PAM if it will operate in system mode. When in system mode, the printer is protected from local copies, unless it is operating with BSC discipline. (The BSC Copy command does not use the PAM; it is directed to the *to* device and specifies the *from* device as a command parameter.)

A printer in **local mode** is used for only local-copy functions regardless of host attachment or communication protocol. Displays within the cluster may contend for the use of the printer, but the host may not. That is, the host cannot use the printer for direct-print operations. The display operator initiates a local copy by using the Print key; if the display is operating in SNA, the host can initiate a local copy from the display buffer.

In **shared mode**, the same printer performs both host-directed printing operations and local-copy operations. The efficiency of local copy operations in shared mode depends on the communication protocol.

In SNA, a printer defined in shared mode may be used for local copy under either of these conditions:

- When the printer is not in session with a primary logical unit (PLU) in the host
- When Between Bracket Printer Sharing (question 213) has been specified in the Configure procedure and the printer is not in bracket state with the PLU in the host.

In non-SNA, shared mode is a less efficient choice for local copy operations. Host application sessions are longer, so there are fewer opportunities for a local copy between host communications.

When operating a printer in shared mode, the user must assume responsibility for the integrity of the printed data by following installation rules and proper programming practices.

Class

In this field, you will enter an **X** (capital letter) under the class or classes defined for the printer.

Some customers may want to group printers into classes, based, for example, on (1) physical characteristics (type font, character set, type of forms mounted), (2) location, or (3) security. You can assign a class number ranging from 70 through 85. In your installation, class 72 may identify all printers with yellow paper. In any configuration, a single printer may be in one class, several, or none.

If you wanted to group several printers in class 72 and authorize the display on port 26-08 to use any of them, you would enter an **X** under Display Port 26-08 on the line for each printer in class 72. If the display then attempted a local copy with a class 72 printer already in use, the local copy would automatically be sent to another available printer in that same class.

Before performing a local copy, the display operator selects a particular printer by class by holding down the ALT key and pressing the IDENT key, and then keying in the authorized class number (70 through 85) next to the printer symbol on the bottom of the screen.

Display Port

Write an **X** under the port for each display authorized to use a particular printer for local copy.

Note: Displays cannot perform local copies on printers that have ASCII hosts designated as their default destination on "Worksheet 22—AEA Default Destination."

Your response in this field defines which displays may use each printer. You can assign more than one display to use the same printer for local copy.

PF Keys

The functions of the PF keys are explained in Chapter 13 under "How to Define the Printer Authorization Matrix (PAM)" on page 13-26.

A Sample PAM

Figure 10-2 shows an example of how the PAM might be defined.

PAM Definition										
Entry	Printer Port	Mode	Class							
			7	8						
			01234	56789	012345					
1	26 - 02	2					
2	26 - 04	1	.X...					
3	26 - 05	1					
4	26 - 06	1	.X...					
5	21 - 03	2	.X...					

Entry	TA Display Port				AEA Display Port					
	26	21	22	23	26	21	22	23	24	25
	0	1	2	3	0	0	0	0	0	0
	01234	56789	01234	56789	01234	56789	01	01234567	01234567	01234567
1	.X...X.	XXX..
2XXX
3X.	XXX..
4XXX
5	XX..XX..

Figure 10-2. Example of a PAM Definition

Entry 1: This printer is cabled to port 26-02. It operates in shared mode (2). It has no class designation. The displays at ports 26-01, 26-13, 26-15, 26-16, and 26-17 all use this printer.

Entry 2: This printer operates in local mode (1). It is designated in class 71 because it prints output on continuous forms. The displays at ports 26-07, 26-08, and 26-09 all use this printer. These displays are also authorized to use the printer attached to port 26-06 (as defined in Entry 4), and the printer attached to port 21-03 (as defined in entry 5), which are also in class 71.

Entry 3: This printer operates in local mode (1). It has no class designation. The displays at ports 26-03, 26-10, 26-11, and 26-12 all use this printer.

Entry 4: This printer operates in local mode (1) and is designated in class 71. The displays at ports 26-07, 26-08, and 26-09 are authorized to use this printer, as well as the printer at port 26-04 (as defined in Entry 2), and the printer at port 21-03 (as defined in Entry 5).

Entry 5: This printer operates in shared mode (2) and is designated in class 71 because it prints output on continuous forms. The displays at ports 21-04, 21-05, 26-05, and 26-06 are authorized to use this printer.

Note: This printer must have a 3270 host designated as its default destination on "Worksheet 22—AEA Default Destination."

Filling Out Worksheet 15—Printer Authorization Matrix (PAM)

1. Locate “Worksheet 15—Printer Authorization Matrix (PAM)” on page 20-17. Make copies of this worksheet (one for every five printer assignments).

2. Decide to which ports you are attaching the printers and displays.

3. Enter your responses in these fields:

Entry: Number each printer you plan to assign for local copy (for example, 1, 2, and 3).

Printer Port: Write the four-digit number of the port to which the printer is attached (for example, 26-18 or 21-02). You cannot assign a printer to port 26-00.

Mode: Write the number of the mode in which the printer will operate.

Class: Write an X under the number that identifies the class(es) defined for the printer. If no class is defined, leave this blank.

Display Port: Write an X under the ports of the displays authorized to use this particular printer.

4. When you finish entering the information for those printers that you want to authorize for local copy, the worksheet is completed.

What's Next?

Return to the “Configuration and Reconfiguration Planning Procedure,” and see step 5 on page 3-6 to determine if there are additional worksheets you need to fill out to complete the planning process. You may also refer to the “3174 Quick-Reference Guide for Planners” to determine where to proceed next.

Chapter 11. Planning to Modify Keyboards

Getting Ready to Plan the Modification of Keyboards	11-3
Overview of the Modify Keyboards Procedure	11-3
Planning Procedure	11-4
Step 1. Locate the Worksheets You Plan to Use	11-4
Step 2. At the Top of the Worksheet, Circle the Keyboard ID	11-4
Step 3. Specify New Layout or Update	11-5
Step 4. Specify the Keyboard Type	11-5
Step 5. Specify the Keypad Type	11-5
Step 6. Specify the Keyboard Language	11-5
Step 7. Fill Out the Keyboard Changes Chart	11-5
Step 8. Indicate with an X Which Keys Will Be Affected	11-9
Step 9. Give a Copy of the Completed Worksheets to the Customizer	11-9
Restrictions	11-9
General	11-9
Local Functions	11-10
APL	11-11
Nomenclature Presentation	11-11
Customizing	11-11
Setting Up the Terminal Keyboards	11-12
Two-Language Modification	11-12
Examples of Two-Language Modification	11-13
Keyboard Languages and I/O Interface Codes Supported	11-17
What's Next?	11-19

Getting Ready to Plan the Modification of Keyboards

The information in this chapter will help you to complete step 5 of the "Configuration and Reconfiguration Planning Procedure." Step 5 is located on 3-6.

Before you start, you will need the following:

- The Keyboard Layout Worksheets in Chapter 20
- The keyboard layouts in Appendix B, "Keyboard and Keypad Layouts" (for visual identification).

If you are planning to copy I/O Code Characters, you may wish to see the *3174 Character Set Reference*, GA27-3831.

Overview of the Modify Keyboards Procedure

The purpose of the Modify Keyboards procedure is to create unique keyboard layouts to be used on IBM display stations with modifiable keyboards. With this procedure, keyboard layouts can be tailored to meet specific user applications. The procedure for modifying two-language keyboards is similar to modifying single keyboards. Information about modifying two-language keyboards appears under the heading "Two-Language Modification."

Notes:

1. This procedure is not for use on the 3290 Information Panel or 3179 Color Display Station. See *3290 Information Panel Description and Reference*, GA23-0021, or *3179 G Color Display Station Description*, GA18-2261, for information on how to modify these keyboards.
2. This procedure cannot be used to modify ASCII keyboards attached through the Asynchronous Emulation Adapter. While active in ASCII host sessions, 3270 display station keyboards will not perform according to modified layouts.

The Modify Keyboard procedure is used to define the modified layout of a maximum of four keyboards. A diagram of the standard keyboard layout (Converged Typewriter, Converged Data Entry, Converged APL, or Enhanced Typewriter) that you select is displayed. By selecting the type of change to be made and positioning the cursor, you redefine the keyboard layout. Most characters, symbols, and functions can be relocated, duplicated, or deleted from almost any key position.

For two-language keyboards, modifying the secondary language nomenclature on the two-language keyboard will, in some cases, also affect the primary nomenclature. These occurrences are described in detail under "Two-Language Modification" on page 11-12.

There are restrictions, as explained under "Restrictions" in this chapter. The actual procedure is explained in Chapter 13.

Planning to Modify Keyboards

During the customizing procedure, the customizer can select which unmodified keyboard layouts (Converged Typewriter, Converged Data Entry, Converged APL, or Enhanced Typewriter) and which of the four possible modified keyboard layouts are to be included in the 3174. The maximum number of unmodified and modified keyboards that can be configured is 4. These customizing sequence numbers apply only to display stations with modifiable keyboards.

After customizing has been performed, the user of a display station with a modifiable keyboard can select which keyboard layout to use. For a modified keyboard layout, the user must change the keyboard to match the layout sheet by changing the keytops or by affixing stick-on labels. Depending on the type of display station, the user identifies the keyboard layout to the 3174 either by switches mounted on the bottom of the keyboard or by a local-mode procedure.

The 3174 supports a PA3 function for the Converged (also referred to as *122-key keyboard*) and Enhanced Typewriter keyboards. The PA3 key, which is sometimes unlabeled, allows a third program attention key to be supported by an application.

Warning: You should check with your system programmer to determine if any of your applications already has a function associated with the PA3 key. If the system programmer determines that pressing the (unlabeled) PA3 key will initiate a harmful action, you should instruct the customizer to use the Modify Keyboard procedure to remove the PA3 key from the keyboard.

Planning Procedure

Use the following steps to plan to modify keyboards. Be sure to review "Restrictions" on page 11-9. The restrictions listed may apply to the changes you wish to make.

Step 1. Locate the Worksheets You Plan to Use

There are five Keyboard Layout Worksheets:

- Converged Non-Katakana
- Converged Katakana
- Enhanced (U.S.)
- Enhanced (World Trade)
- Enhanced (Katakana).

Remove the worksheets you plan to use from Chapter 20. The keyboard users will need copies of the completed worksheets to set up their keyboards. Duplicate the worksheets as needed, but be sure to keep one blank copy of each worksheet for future planning.

Step 2. At the Top of the Worksheet, Circle the Keyboard ID

The keyboard IDs represent the modified or unmodified keyboards for which the control unit has been configured. To determine which IDs are to be supported, check the response to configuration question 137 on your host related worksheet.

Step 3. Specify New Layout or Update

If you are planning changes to a keyboard that already exists in the Modify Keyboard tables (within the microcode files), check the box indicating "Update." If you are planning to enter a new keyboard into the Modify Keyboard tables, check the box indicating "New Layout."

Step 4. Specify the Keyboard Type

Planner: This step does not apply to Enhanced keyboards. If you are modifying an Enhanced keyboard, proceed to step 5.

Put a check in the "Keyboard Type" box that applies to the keyboard you are modifying: Typewriter, Data Entry, or APL.

Step 5. Specify the Keypad Type

Put a check in the "Keypad Type" box that applies to the keyboard you are modifying: National Language Numeric, Data Entry, or Program Function (PF).

Step 6. Specify the Keyboard Language

Put in the appropriate language number (found in Table 11-1 on page 11-17) on the line beside "Keyboard Language," which is located just above the Keyboard Changes Chart on the worksheet.

Warning: If you specify a keyboard language that has characters **unique** to APL2 and CECP, you need to ensure that a device capable of supporting those characters will be used. If you use a device that does not support those characters, they may be misrepresented or displayed as blanks.

Step 7. Fill Out the Keyboard Changes Chart

Figure 11-1 is an example of a blank Keyboard Changes Chart.

Keyboard, Shift, and Function Groups										From Key		I/O interface		To Key	
										Shift	Character	Code	Character	Shift	Character
0	1	2	3	4	5	6	7	8							
0	1	2	3	4	5	6	7	8							
0	1	2	3	4	5	6	7	8							
0	1	2	3	4	5	6	7	8							
0	1	2	3	4	5	6	7	8							
0	1	2	3	4	5	6	7	8							
0	1	2	3	4	5	6	7	8							
0	1	2	3	4	5	6	7	8							
0	1	2	3	4	5	6	7	8							
0	1	2	3	4	5	6	7	8							

Figure 11-1. Example of a Blank Keyboard Changes Chart

Using the information in Figure 11-2 on page 11-6 and the definitions under "Keyboard Changes Chart Column Definitions" on page 11-8, fill in the Keyboard Changes Chart (located at the bottom of the worksheet) with the modifications you plan to make.

Planning to Modify Keyboards

7-1: Mark an X over the Keyboard, Shift, and Function groups. Using Figure 11-2 as a reference, determine which number applies for **each** group. Place an X over the appropriate numbers. **You must choose one number from each group.**

0, 1, 2 – Keyboard Group

- 0 = The change you want to make is on a Converged Typewriter, Converged Data Entry, or Enhanced Typewriter keyboard.
- 1 = The change that you want to make applies only to the APL key functions on a Converged APL keyboard.
- 2 = The change that you want to make applies to both the typewriter and APL functions of the keys involved on a Converged APL keyboard.

3, 4 – Shift Group

- 3 = Full-key change (includes alternate, upper, and lower shifts).
- 4 = Single-shift change.

5, 6, 7, 8 – Function Group

- 5 = Copy from I/O interface code table.
- 6 = Exchange two functions.
- 7 = Copy a function to another key.
- 8 = Delete a key function.

Figure 11-2. Keyboard, Shift, and Function Groups – Keyboard Changes Chart

7-2: Designate Upper Shift, Lower Shift, Alternate, or All in the **From** Key Shift Column. The *From* key is the key you will be moving, copying, or deleting.

Note: In the case where you will be copying a character from the I/O Interface Code Characters chart, see step 7-4.

After you have determined which shift of the character should be changed, indicate the shift or "All" (in the case where you wish to change the entire key) in the shift column for the *From* key.

7-3: Write in the character or function for the **From** key. Write in the appropriate character (for example, "A") or function (for example, the "Forward" function), in the Character column for the *From* key.

Planner: The following step applies only if you are copying an I/O Interface Code from the I/O Interface Code tables. See step 7-4 for a definition of I/O interface codes and a description of how they are used.

If you are not copying an I/O Interface Code, skip Step 7-4 and proceed with Step 7-5.

7-4: Write in the I/O Interface Code and character. The I/O Interface Code Characters are characters that are not standard on the keyboard. To allow the character to be used on the keyboard you are modifying, you must copy the character from the I/O Interface Code Character tables. These tables are located within the Modify Keyboard files, but must be indicated to the Modify Keyboards program by a hexadecimal code. (The hexadecimal codes can be found in the *3174 Character Set Reference*, GA27-3831.)

After determining which I/O interface code character you wish to copy from the I/O Interface Code Tables, write the hexadecimal code given for that character, **and** the actual character you want copied, in the applicable columns of the Keyboard Changes Chart.

7-5: Designate Upper Shift, Lower Shift, Alternate, or All in the **To** Key Shift Column. The **To** key is the key to which you are copying or moving the character or function.

The shift indicates which shift position on the **To** key will receive the **From** key character or the I/O interface code character.

Note: Be sure to review "Restrictions" on page 11-9.

7-6: Write in the Character or Function for the **To** key. In the event that you wish to have characters, functions, or an entire key exchanged or replaced, you will want to indicate which character, function, or entire key you wish to exchange with the **From** key. Write in the appropriate character (for example, "A") or function (for example, the "Forward" function), in the Character column for the **To** key.

Note: In the event that the **To** key does not have a character or function on the shift position to which you plan to move the **From** key character, use one of the characters or functions on the **To** key, to identify the **To** key's location.

Planning to Modify Keyboards

Keyboard Changes Chart Column Definitions

Refer to the following definitions while completing the Keyboard Changes Chart:

Column	Definition
0, 1, 2, 3, 4, 5, 6, 7, 8	Numbers indicating the keyboard, shift, and function groups.
From Key Shift	Designates which shift position(s) of the key should be moved, deleted, or copied.
From Key Character/Function	Designates the character or function on the <i>From</i> key that will be deleted, moved, copied, or exchanged.
I/O Interface Code	A hexadecimal code that represents a character not normally on the keyboard. These codes can be found in the I/O Interface Code Character tables of the <i>3174 Character Set Reference</i> , GA27-3831.
I/O Interface Code Character	A character that is not normally on the keyboard, but that can be added through the use of hexadecimal codes entered in the Modify Keyboards files of the control unit.
To Key Shift	Designates which shift position(s) on the <i>To</i> key will receive the <i>From</i> key character or the I/O interface code character.
To Key Character/Function	Designates the character or function on the <i>To</i> key that will be exchanged with the <i>From</i> key character, that will be replaced by the <i>From</i> key character or I/O interface code character, or that indicates the <i>To</i> key position on the keyboard.

Following is an example of planning a simple keyboard modification using the Keyboard Changes Chart.

Example: In this example, the planner has already specified that the keyboard is Non-Katakana, Typewriter, PF, and a new layout.

In the Keyboard Changes Chart below, the planner has indicated that he wishes:

- To perform an exchange of the X key (uppershift position) with the A key (uppershift position).
- To copy the plus (+) key from the I/O Interface character table (hex 4E) to replace the Z key (alternate position).

Keyboard, Shift, and Function Groups										From Key		I/O Interface		To Key	
										Shift	Character	Code	Character	Shift	Character
X	1	2	3	X	5	X	7	8	Upper	X			Upper	A	
X	1	2	3	X	X	6	7	8			4E	+	Alternate	Z	

Figure 11-3. Example of a Completed Keyboard Changes Chart

Step 8. Indicate with an X Which Keys Will Be Affected

When you have completed the Keyboard Changes Chart, you can indicate on the keyboard worksheet which keys will be affected by the Modify Keyboards changes; this will help the person performing the actual procedure to locate the affected keys quickly.

Note: In the event that the *3174 Character Set Reference*, GA27-3831, does not have the keyboard layout for the keyboard you are modifying, see the keyboard documentation for visual identification.

Step 9. Give a Copy of the Completed Worksheets to the Customizer

When you have completed filling out all the worksheets, give a copy of each worksheet to the person who will perform the Modify Keyboard procedure. Information on how to perform the actual procedure can be found in Chapter 13.

Restrictions

The restrictions have been grouped into four categories:

- General
- Local Functions
- APL
- Nomenclature Presentation.

General

- A maximum of four keyboard layouts are identified by this procedure.
- The following are mandatory key functions and must be included on the modified keyboard layouts:

Alternate shift	Test
Enter	System request
Reset	Upshift or downshift.
Device cancel	

Exceptions:

For the Katakana Converged keyboards: The Japanese English upper and lower shift key functions are mandatory key functions and must be included on the modified keyboard layout.

For the Greek, Cyrillic, and Thai modifiable keyboards: The Latin shift key function is a mandatory key function and must be included on the modified keyboard layout.

- A make/break key cannot be copied to a non-make/break key, nor can a non-make/break key be copied to a make/break key.

The make/break keys are:

Shift Lock	ALT (two keys)
Upshift (two keys)	ENTER (on main keyboard only)
RESET/DEV CNCL	Downshift (Data Entry keyboard only).

Planning to Modify Keyboards

- Caps Lock and Shift Lock functions can be moved to another key in full-shift mode and moved around within a key in single-shift mode. However, all shifts of the modified key must contain the Caps Lock or Shift Lock function, in any arrangement.
- “Fwd” and “Back” (the scroll forward and backward functions) can be moved, but they are not operative for all modifiable keyboards.
- Not all display stations with modifiable keyboards support the Data Entry keyboard layout.
- Extended Select key functions (including Entry Assist, X.21, and X.25) cannot be modified.
- Shift keys (for example, Up-shift, Down-shift, and Alt-shift) cannot be modified in a single shift change.
- On Typewriter and APL keyboards with the keyboard numeric lock feature, the keyboard is automatically downshifted when the cursor enters a numeric field; on Data Entry keyboards, the keyboard is automatically upshifted. You must keep this in mind when modifying a keyboard with this feature, because the automatic shifting remains in effect regardless of keyboard layout modification. For example, when a Typewriter keyboard layout has been modified, if any numbers are moved from downshift to upshift key locations, the operator must override the automatic downshift in a numeric lock field (by pressing the Shift key) before keying in the upshift numbers.
- The procedure will always display Wd Del (Word Delete), but to activate this function, the 3174 must be configured for Entry Assist.
- Only characters resident in the I/O interface code page for the language that was selected can be added to the keyboard. For example, only the characters from the Cyrillic I/O interface code page can be used to add a character to the keyboard while you are modifying Cyrillic keyboards.

Local Functions

- Keyboard local functions are not displayed and are not modifiable.
- Local keys (for example, SETUP, RECORD, and PLAY keys) on modifiable keyboards do not send signals to the 3174. (See your terminal user’s guide to find out if your terminal’s keyboard has local keys.) Any key functions that are moved to these “local” key locations will not be recognized by the 3174. This restriction does not apply to modifiable keyboards that do not implement these local keys.
- The procedure will not prevent moving functions to or from the keys associated with the local key functions. When a modifiable keyboard is performing a local function, however, all key functions revert to the positions of the standard keyboard. For example, assume that the ALT key function was exchanged with the ENTER key. During setup mode, then, the original ALT key (now labeled ENTER) must be pressed when the “Alternate” function is required.

APL

- Not all display stations with modifiable keyboards support the APL keyboard.
- The display station connected to port 26-00 must have an APL read-only storage (ROS) to modify APL characters.
- A display station must have an APL2 ROS in order to display APL2 characters correctly.
- APL key functions cannot be exchanged with Typewriter key functions.

Nomenclature Presentation

- When a key nomenclature of n characters (where $n > 3$) is moved to a key of less-than- n characters, the nomenclature is truncated. For example, exchanging the Print key with the letter Q key causes Pri to be displayed on the new "print" key.
- The display station connected to port 26-00 must have a primary language read-only storage (ROS) to display the corresponding primary language characters. However, these characters are modifiable whether the primary language ROS is present or not. (This note applies to Katakana, Greek, Turkish, Icelandic, ROECE, Yugoslavic, Cyrillic, and Thai.)
- For CECP characters to be supported, the control unit must be customized for CECP, and displays that support CECP must be used. See the *3174 Character Set Reference*, GA27-3831, for the devices that support CECP.
- For any CECP language, characters that are unique to the CECP ROS may not be displayed correctly unless the display being used has a CECP ROS.

Customizing

To modify keyboards, it is necessary to answer questions 136 and 137 on the applicable Host Attachment Worksheet; these questions are used to determine how many keyboards will be modified and the total number of keyboard types that will be supported.

Although as many as four modified keyboard layouts can be defined with this procedure, the total number of unmodified and modified keyboard layouts (question numbers 136 and 137) selected during customizing cannot exceed 4. For example, if three unmodified keyboards are selected, then only one of the four modified keyboards can be selected.

If you have not already completed the Host Attachment Worksheet, you may wish to complete it now.

Setting Up the Terminal Keyboards

The users of display stations with modifiable keyboards need to know which keyboard layouts have been customized for their control unit. Copies of the modified keyboard layouts that have been defined with this procedure should be given to these users so that they can set up their keyboards.

Instructions on how to set up a modified keyboard layout are in the operator's guide for each display station with a modifiable keyboard.

The customer is responsible for all changes he makes to the keyboard. That is, before submitting a keyboard for exchange or repair, the customer should remove all special keytops he has installed on his keyboard, because he will receive a keyboard with the standard key layout in return for any keyboard submitted for exchange or maintenance.

Two-Language Modification

Code Page Considerations: In some two-language code pages, there may be an I/O interface code that is duplicated between the primary and secondary languages. While modifying the secondary language keyboard, you may use only the secondary duplicated character. While modifying the primary language keyboard, you may use only the primary duplicated character. For example, a Latin (secondary language) capital A and a Greek (primary language) capital alpha look similar, but the Latin A is hex C1, and the Greek alpha is hex 41.

Hidden Keyboard Considerations: When the primary language code is specified on the master panel of this procedure, the keyboard layouts of two languages—for instance, the Katakana keyboard layout and the Japanese English keyboard layout—can be displayed.

There are occasions when a modification made to the primary language (Katakana, Greek, Cyrillic, and Thai) keyboard layout will also be made to the secondary language keyboard layout. For example, if the Katakana keyboard layout is displayed and PF7 is deleted, the PF7 on the hidden (Japanese English) keyboard layout may also be deleted. The reverse is also true. When a modification is made to both languages, an indication is displayed on the display screen. (This indication and how to move between the keyboard layouts are explained within the procedure in Chapter 13.)

A two-language modification will occur (unless you are modifying a keyboard where the keyboard group selection is equal to a 1, meaning APL only) in the following circumstances:

- When you are modifying function keys on the keyboard; for example, program function keys, control keys, and shift keys. With some exceptions, most of these keys appear gray on the keyboard.

If you are modifying a graphic key, a two-language modification will **not** occur. Graphic keys produce alphanumeric and national characters on the screen. With some exceptions, these are the white keys on the keyboard.

- When you are exchanging or copying a function between two keys, or deleting the function of a key.

If you are copying a character from an I/O interface code table, two-language modification will **not** occur.

- If the modification involves the full key (both upper and lower shift positions), and the upper and lower shift positions on the displayed keyboard layout and on the hidden keyboard layout are the same. See “Examples of Two-Language Modification” for illustrations of this condition.
- When the modification involves a single-shift (either the upper or lower shift position) key, and the corresponding keys on both the displayed keyboard and the hidden keyboard are the same. See “Examples of Two-Language Modification” for illustrations of this condition.

Examples of Two-Language Modification

The examples in Figures 11-4 and 11-5 illustrate cases when a two-language modification will and will not occur. They use the Japanese English keyboard layout as the displayed keyboard and the Katakana keyboard layout as the hidden keyboard. However, the same result would occur regardless of which keyboard is hidden or displayed. The keyboard layouts used in the examples represent the control keys on the left side of the Typewriter keyboard. The characters displayed on the boxes, however, do not represent any real function; they are used here for illustration only.

The same applies to Latin-Greek, Latin-Cyrillic, and Latin-Thai language keyboard layouts.

Deleting Key Functions

The first and second sets of boxes on the left in Figure 11-4 represent the layout of function keys on the left-hand side of the Japanese English Typewriter keyboard that is displayed on the screen. They show the keyboard **before** and **after** the Modify Keyboard procedure was used to delete a key function. The third and fourth sets of boxes, on the right, represent the corresponding keys on the hidden (Katakana) Typewriter keyboard layout. They show what can happen to the hidden keyboard when keys are deleted on the displayed keyboard.

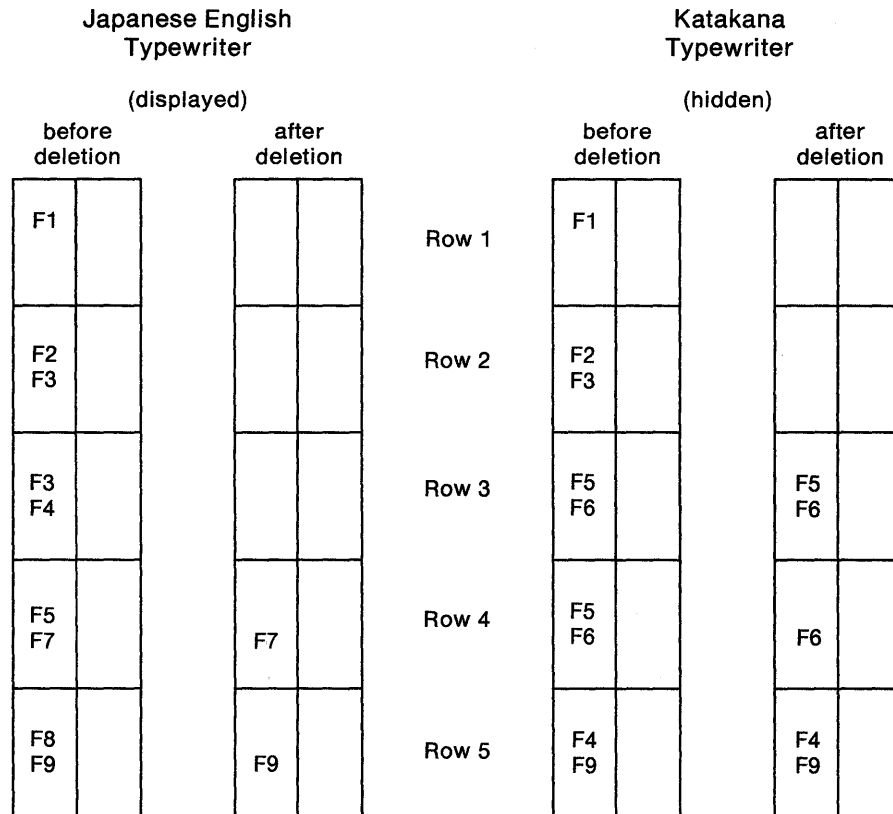

- Row 1:** Full-key deletion; both the displayed and hidden keyboards are modified because they are functionally the same.
- Row 2:** Full-key deletion; both the displayed and hidden keyboards are modified because they are functionally the same.
- Row 3:** Full-key deletion; the key on the displayed keyboard and the corresponding key on the hidden keyboard are functionally different. The hidden key is not modified.
- Row 4:** Single-shift deletion of the upper shift function occurs on both keyboards because the upper shift functions of both keys are the same.
- Row 5:** Single-shift deletion; the upper shift function of the key on the displayed keyboard is functionally different from the corresponding key on the hidden keyboard. The hidden keyboard is not modified.

Figure 11-4. Deleting Key Functions

Copying from One Key to Another Key

Note: The following examples also apply when you are exchanging the functions of two keys.

The first and second sets of boxes on the left in Figure 11-5 represent function keys on the Japanese English Typewriter keyboard layout that is displayed on the screen. They show the **before** and **after** states of copying a key function to the neighboring key. The third and fourth sets of boxes represent the corresponding keys on the hidden (Katakana) Typewriter keyboard layout. They show what will happen to the hidden keyboard when keys are copied on the displayed keyboard.

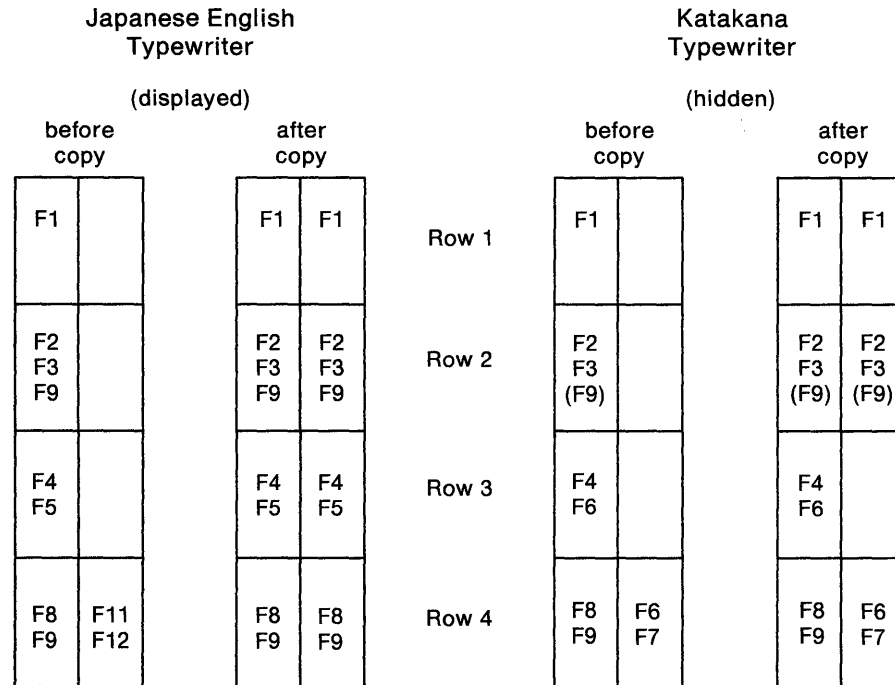

- Row 1:** Full-key copy; both the displayed and hidden keyboards are modified because they are functionally the same. The function in the alternate location is copied to the Katakana keyboard, but is not displayed.
- Row 2:** Full-key copy; both the displayed and hidden keyboards are modified because they are functionally the same in the upper and lower positions. The function in the alternate location is copied to the Katakana keyboard, but is not displayed.
- Row 3:** Full-key copy; the key on the hidden keyboard is not modified, because the corresponding keys are not functionally the same in both upper and lower shift positions.
- Row 4:** Full-key copy; the corresponding keys on the hidden keyboard are not modified, because the target key (the key being copied to) is functionally different from the target key on the displayed keyboard.

Figure 11-5 (Part 1 of 2). Copying from One Key to Another Key

Planning to Modify Keyboards

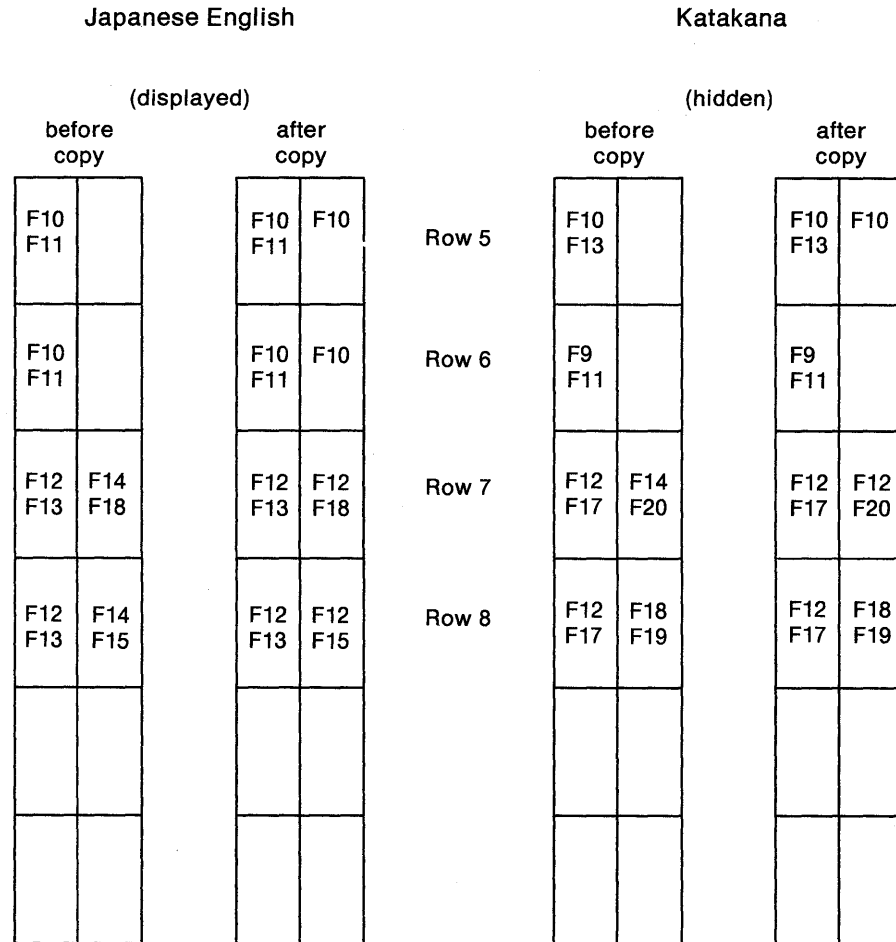

- Row 5:** Single-shift copy of the upper shift function; the corresponding keys on the hidden keyboard are modified because the upper positions of both keys are functionally the same.
- Row 6:** Single-shift copy of the upper shift function; the corresponding keys on the hidden keyboard are not modified, because the upper position of the corresponding key on the hidden keyboard is functionally different from the corresponding key on the displayed keyboard.
- Row 7:** Single-shift copy of the upper shift function; the corresponding keys on the hidden keyboard are modified because the upper position of the target key (the key being copied to) is functionally the same as the corresponding key on the displayed keyboard.
- Row 8:** Single-shift copy of the upper shift function; the keys on the hidden keyboard are not modified, because the upper position of the target key (the key being copied to) is functionally different from the corresponding key on the displayed keyboard.

Figure 11-5 (Part 2 of 2). Copying from One Key to Another Key

Keyboard Languages and I/O Interface Codes Supported

Table 11-1. Keyboard Languages and Character Set I/O Interface Codes Supported

Keyboard Language	I/O Interface Code ⁵	Converged (122-Key) Keyboard Functions Supported			Enhanced Type-writer Keyboard	Response
		Type-writer	Data Entry	APL		
English (U.S.) EBCDIC	English (U.S.) CECP	✓	✓	✓	✓	01
English (U.S.) ASCII	ASCII-7	✓				02 ¹
Austrian/German	Austrian/German CECP	✓	✓	✓	✓	03
Belgian	Belgian	✓		✓		04
Danish	Danish/Norwegian CECP	✓	✓	✓	✓	07
Finnish	Finnish/Swedish CECP	✓	✓	✓	✓	09
Italian	Italian CECP	✓	✓	✓	✓	15
Japanese (Katakana)	Japanese (Katakana)	✓	✓	✓	✓	17
Spanish	Spanish CECP	✓		✓	✓	19
Spanish-speaking	Spanish-speaking CECP	✓	✓	✓	✓	21
English (U.K.)	English (U.K.) CECP	✓	✓	✓	✓	22
Norwegian	Danish/Norwegian CECP	✓	✓	✓	✓	23
Swedish	Finnish/Swedish CECP	✓	✓	✓	✓	24
Portuguese	Portuguese CECP	✓	✓	✓	✓	28
Canadian (Bilingual)	Canadian (Bilingual) CECP	✓	✓	✓	✓	29
French AZERTY	French CECP	✓	✓	✓	✓	30
English (U.S.) ASCII	ASCII International	✓		✓		33 ²
English (U.S.) ASCII	ASCII-8	✓				34 ³
Cyrillic	Cyrillic	✓			✓	35
Greek	Greek	✓			✓	36
Icelandic	Icelandic	✓			✓	37
ROECE ⁴	ROECE/Latin	✓			✓	38
Turkish	Turkish	✓			✓	39
Yugoslavic	Yugoslavic	✓			✓	40
New Swiss French	Swiss French (New) CECP	✓		✓	✓	41
New Swiss German	Swiss German (New) CECP	✓		✓	✓	42
New Belgian	Belgian (New) CECP	✓		✓	✓	43
Thai	Thai				✓	46
Netherlands	Netherlands CECP	✓	✓	✓	✓	47

¹Available on remote models only. Does not support Extended Data Stream.

²Available on BSC, Local SNA, and Local Non-SNA only.

³Available on SDLC and X.25 only.

⁴Regional Office for Eastern and Central Europe.

⁵See the 3174 Character Set Reference, GA27-3831, for the graphics and code page points.

Planning to Modify Keyboards

Each of the languages supported by the Modify Keyboard procedure uses the key function nomenclature of one of the following languages:

- English
 - Belgian
 - Cyrillic
 - Danish
 - Finnish
 - Greek
 - Icelandic
 - Netherlands
 - New Belgium
 - Norwegian
 - Portuguese
 - ROECE
 - Swedish
 - Thai
 - Turkish
 - Yugoslavic
 - U.K. English
 - U.S. English
- French
 - Canadian (Bilingual)
 - French (AZERTY 105)
 - New Swiss/French
- German
 - Austrian/German
 - New Swiss/German
- Italian
 - Italian
- Spanish
 - Spanish
 - Spanish-speaking
- Japanese
 - Katakana.

For example, when a keyboard panel for a Finnish keyboard is displayed, the key function is displayed in English. Table 11-2 on page 11-19 lists the key functions and the corresponding displays.

Table 11-2. Key Function Nomenclature					
Key Function	Key Function Display				
	English	French	German	Italian	Spanish
Attention	Attn	Attn	Abruf	Attn	Atenc
Clear	Clear	EfEcr	Losch	Annul	Borra
System Request	SysRq	Syst	S-Abf	Sist	PtSis
Cursor Select	CrSel	SelCr	AwPos	SelCr	SelCr
Erase Input	ErInp	EfEnt	E-Lo	ImCan	BorEn
Erase to End of Field	ErEOF	EfFZn	LoFld	FCCan	BrFDC
Extend Select	ExSel	2eSel	ErAus	EsSel	ExSel
Print	Print	Impr	Druck	Stamp	Impr
Ident	Ident	Ident	Ident	Ident	Ident
Test	Test	Test	Test	Prova	Prba
Shift Lock	ShLck	VrMaj	UmVer	FMaiu	BIMay
Up Shift	UpSh	Maj	UmObn	Maius	Mayus
Reset	Reset	Rest	Grdst	Ripr	Rest
Device Cancel	DvCnl	AnnOp	Eh-Lo	AnTrs	CancD
Alternate Shift	Alt	FnSel	Alt	Altrn	Altva
Space	Space	Esp	Leer	Spaz	Espac
Enter	Enter	Entr	DatFr	Invio	Intro
Home	CrHom	Posl	GrPos	Posiz	IncCr
Cursor Down	CrDwn	CrBas	UnPos	CrGiu	BajCr
Cursor Up	CrUp	CrHt	ObPos	CrSu	SubCr
Insert	Ins	Inser	Eifug	Inser	Inser
Delete	Del	Suppr	Z-Lo	Canc	Supr
Delete Word	WdDel	SpMot	W-Lo	PCanc	SupP1
Duplicate	Dup	Repro	Dup	Dup	Dup
Field Mark	FldMk	FinZn	FeldM	MC	MCamp
PA1—PA3	PA1—PA3	AP1—AP3	PA1—PA3	AP1—AP3	AP1—AP3
Cursor Blink	CrBnk	ClgCr	BIPos	IntCr	ParCr
Alternate Cursor	CrAlt	TypCr	UPos	CAIt	CrAlt
Clicker (On/Off)	Click	Clic	Klick	Segn	Clic
PF1—PF24	P1—P24	P1—P24	P1—P24	F1—F24	F1—F24
Down Shift	DwnSh	Min	UmUnt	Minus	Minus
Window Forward	Fwd	Avant	Vorw	Avant	Avnce
Change Screen	ChgSc	ChgSc	ChgSc	ChgSc	Chgsc
Window Back	Back	Arr	Ruck	Indtr	Retro
Backspace	<-	<-	<-	<-	<-
Carrier Return	<-	<-	<-	<-	<-
Tab Right	->	->	->	->	->
Tab Left	<-	<-	<-	<-	<-
Fast Cursor Left	<<<-	<<<-	<<<-	<<<-	<<<-
Fast Cursor Right	->>>	->>>	->>>	->>>	->>>
Cursor Left	<-	<-	<-	<-	<-
Cursor Right	->	->	->	->	->
Capslock	CapLk	CapLk	CapLk	CapLk	CapLk

What's Next?

Return to the "Configuration and Reconfiguration Planning Procedure," and see step 5 on page 3-6 to determine if there are additional worksheets you need to fill out to complete the planning process. You may also refer to the "3174 Quick-Reference Guide for Planners" to determine where to proceed next.

Part 3. Procedures

Chapter 12. How to Display the Master Menu

Chapter 13. How to Customize the Control Disk

- Customize the Control Disk Overview
- Configure Overview
- How to Configure the Control Disk
- How to Define the PAM
- Merge RPQ Overview
- How to Merge RPQs
- Modify Keyboards Overview
- How to Modify Keyboards
- How to Configure the AEA

Chapter 14. How to Merge DSL Code

Chapter 15. How to Copy Files

Chapter 16. How to Upgrade Microcode

Chapter 17. How to Initialize the Encrypt/Decrypt Feature

Chapter 18. How to Perform Media Management

Chapter 19. How to Identify Customizing Keyboards

Chapter 12. How to Display the Master Menu

Getting Ready to Display the Master Menu	12-3
Overview	12-3
Before Starting the Alt 1 IML Procedure	12-4
If IMLing from a diskette drive	12-5
If IMLing from a fixed disk drive	12-5
How to Insert Diskettes – Models 1L, 1R, 2R, and 3R	12-6
How to Insert Diskettes – Models 51R, 52R, 53R, 81R, and 82R	12-6
How to Display the Master Menu – Remote (R) Models	12-7
How to Display the Master Menu – Model 1L	12-10

Getting Ready to Display the Master Menu

Before you start, you will need the following:

- A 3174 Utility disk (diskette or fixed disk).
- A *customizing display station* attached to port 26-00 of the control unit. See Chapter 1, "For First-Time Users" for a list of display stations that can be used.

You may need to see the *3174 Status Codes*, GA27-3832, for information on the status codes.

Overview

To select a procedure from the Master Menu (Figure 12-1), you must first display it on your screen. To display this menu, you perform one of the Alt 1 IML procedures described in this chapter. **Before performing this procedure for the first time, read through these instructions carefully.** The steps you will follow vary, depending on the 3174 model you are using, its disk drives, and whether the control unit is on or off when you start the procedure. See the *3174 User's Guide* for your control unit model for complete operating procedures and problem determination.

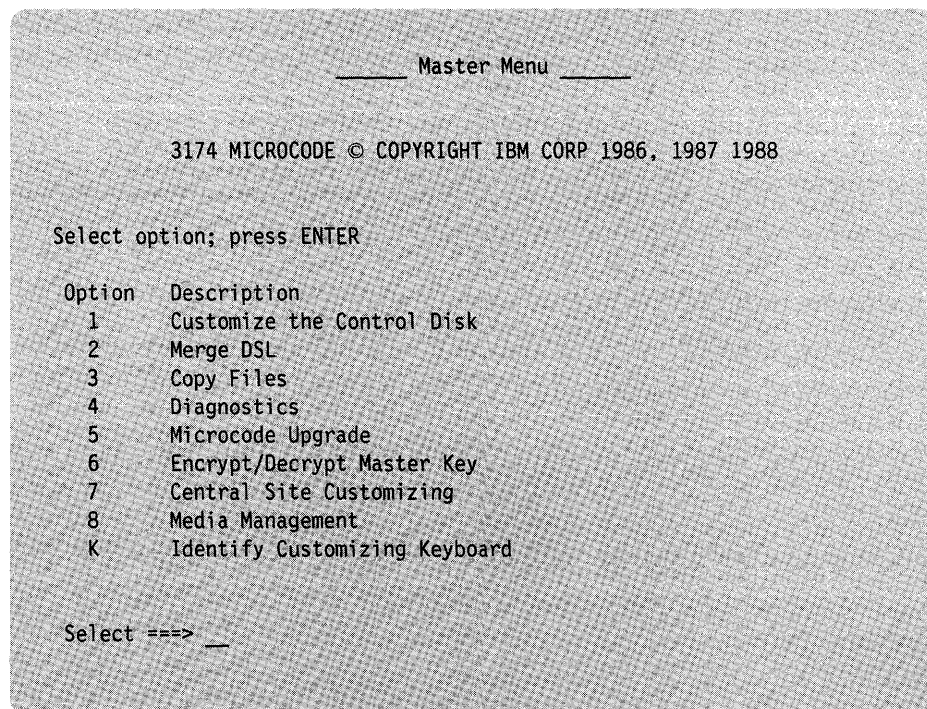

Figure 12-1. The Master Menu

Note: When the Master Menu is displayed, if it does not contain all of the options shown in Figure 12-1, you have the Limited Function Utility Disk. For an explanation of this optional disk, see Appendix C, "Limited Function Utility Disk."

Before Starting the Alt 1 IML Procedure

Notice the location of the switches and pushbuttons on the front panel of the control unit. See Figure 12-2 through Figure 12-4.

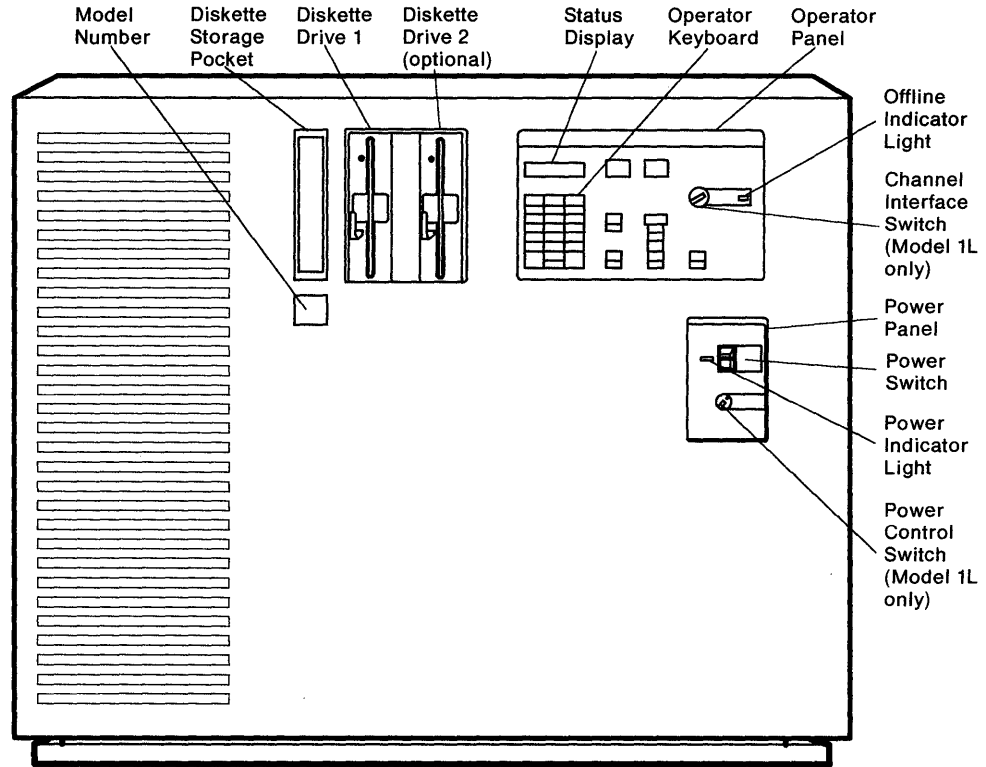

Figure 12-2. 3174 Models 1L, 1R, 2R, and 3R

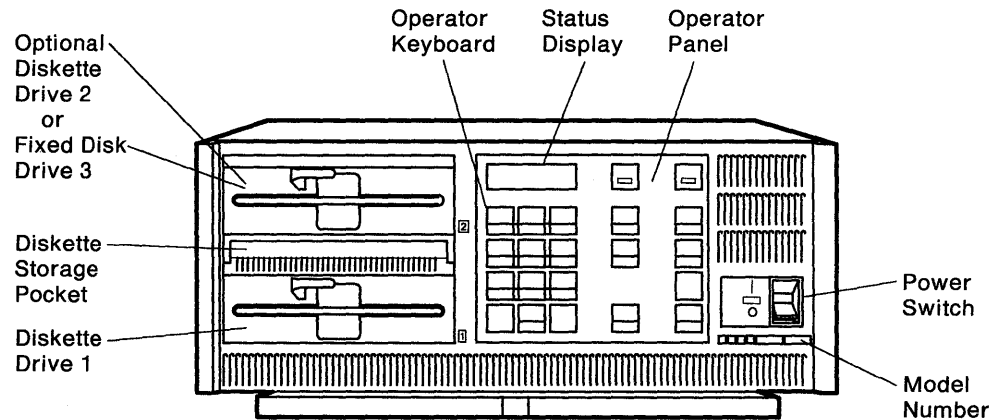

Figure 12-3. 3174 Models 51R, 52R, and 53R

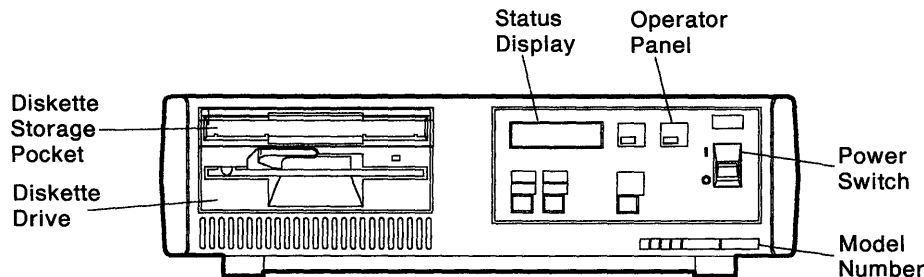

Figure 12-4. 3174 Models 81R and 82R

If IMLing from a diskette drive

If you are IMLing from a diskette drive, see:

- “How to Insert Diskettes – Models 1L, 1R, 2R, and 3R” on page 12-6, and
- “How to Insert Diskettes – Models 51R, 52R, 53R, 81R, and 82R” on page 12-6.

Then follow the appropriate procedure:

- “How to Display the Master Menu – Remote (R) Models” on page 12-7
- “How to Display the Master Menu – Model 1L” on page 12-10.

The model number of the control unit you are using is located on the front of the machine.

If IMLing from a fixed disk drive

Copies of the 3174 Control and Utility microcode must be on the fixed disk, and the Utility disk must be selected to be included in the Alt 1 IML. If this has not been done, you will have to IML from a diskette drive. Chapter 15, “How to Copy Files” and Chapter 18, “How to Perform Media Management” contain the procedures for copying and selecting the IML source.

If the above requirements have been met, follow the appropriate procedure:

- “How to Display the Master Menu – Remote (R) Models” on page 12-7
- “How to Display the Master Menu – Model 1L” on page 12-10.

Note: Models 81R and 82R do not support fixed disk drives.

The model number of the control unit you are using is located on the front of the machine.

How to Insert Diskettes – Models 1L, 1R, 2R, and 3R

Diskettes for the control unit are kept in the storage pocket next to the diskette drive(s).

1. Remove the diskette from its envelope.
2. Turn the drive lever to the up position.
3. Hold the diskette by the label with the label facing to the *left*.
4. Insert the diskette into a drive.
5. Close the drive by turning the lever down.

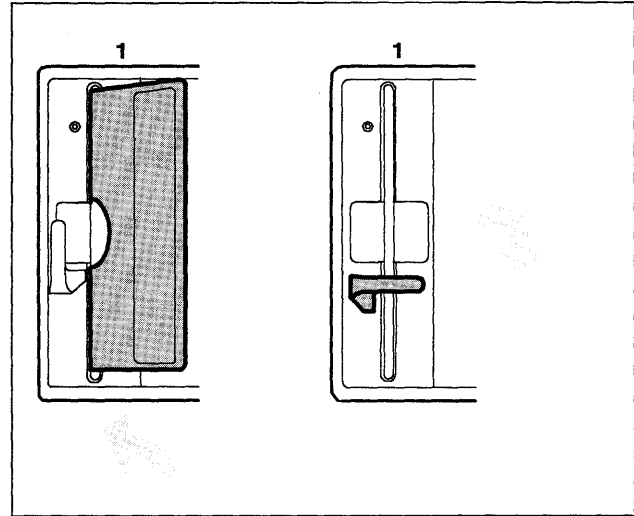

How to Insert Diskettes – Models 51R, 52R, 53R, 81R, and 82R

1. Remove the diskette from its envelope.
2. Turn the drive lever to the up position.
3. Hold the diskette by the label with the label facing *up*.
4. Insert the diskette into a drive.
5. Close the drive by turning the lever down.

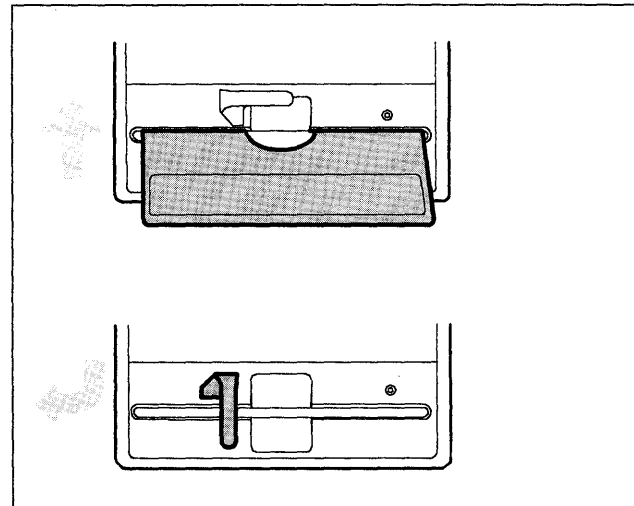

How to Display the Master Menu – Remote (R) Models

Warning: This procedure interrupts all host services. Notify users if necessary.

1

Turn on the *customizing display station*. (See the documentation that accompanies your display station, if necessary.)

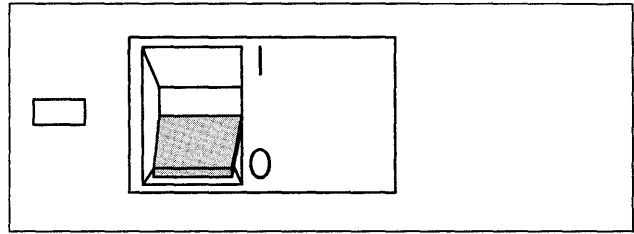

If IMLing from a **diskette drive**, continue with step 2.

If IMLing from a **fixed disk drive**:

- Go to step 3 if the control unit is turned *off* (the green light on the power panel is off).
- Go to step 4 if the control unit is turned *on* (the green light on the power panel is on).

2

Open diskette drive 1 and insert a Utility diskette. Close the diskette drive.

Note: The example illustrated shows the Utility diskette being inserted into diskette drive 1 of a 3174 Model 1R or 2R.

- Continue with step 3 if the control unit is turned *off* (the green light on the power panel is off).
- Go to step 4 if the control unit is turned *on* (the green light on the power panel is on).

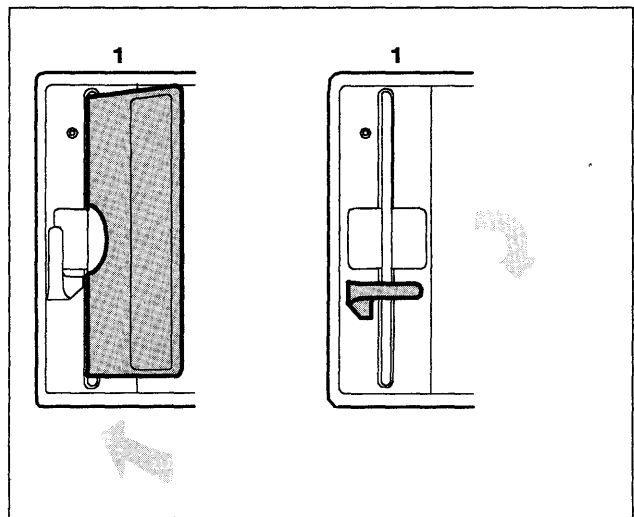

3

The control unit is turned *off*.

1. Press and hold the Alt 1 pushbutton on the operator panel.
2. While holding the Alt 1 pushbutton, lift and release the On/Off switch on the power panel.

Go to step 5.

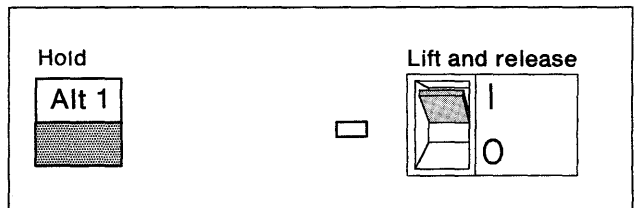

How to Display the Master Menu

4

The 3174 is turned *on*.

1. Press and hold the Alt 1 pushbutton on the operator panel.
2. While holding the Alt 1 pushbutton, press and release the IML pushbutton.

Continue with step 5.

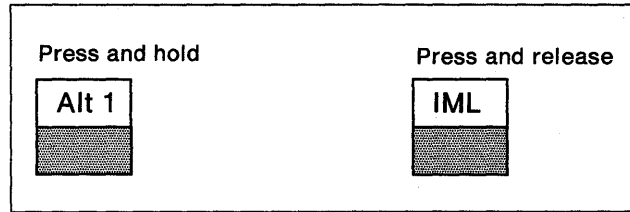

5

When you see 31 in the status indicators, release the Alt 1 pushbutton.

If the correct numbers do not appear, see *3174 Status Codes*, GA27-3832.

If you are IMLing from a *diskette*, continue with step 6.

If you are IMLing from a *fixed disk*, go to step 7.

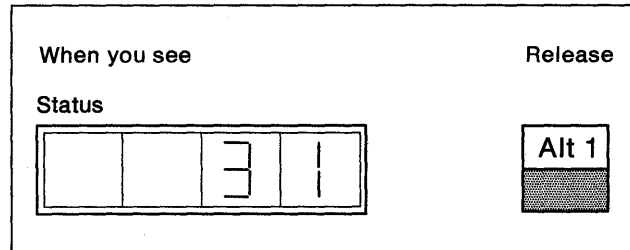

6

If IMLing from a *diskette*: when you see 40 in the status indicators, press and release the ENTER pushbutton on the operator panel. Wait for 7000 to appear in the status indicators.

Go to step 8.

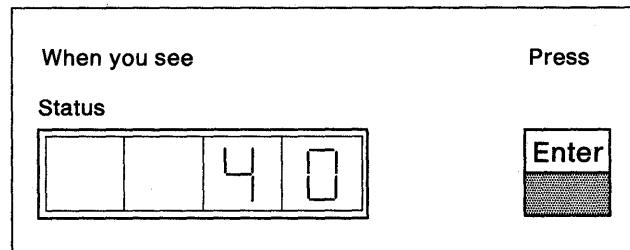

7

If IMLing from a *fixed disk* (the fixed disk must contain the Utility microcode):

1. When you see 40 in the status indicators, type in (using the operator's keyboard on the control unit) **0340** to IML from fixed disk 3 or **0440** to IML from fixed disk 4.
2. Press and release the ENTER pushbutton on the operator panel.

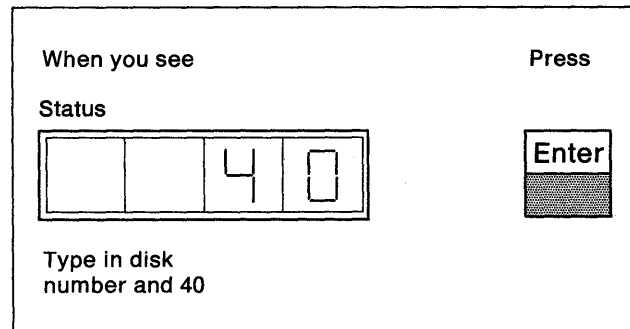

8

In a few moments the Master Menu panel appears on the display screen. The title "Master Menu" should be highlighted. If it is not, adjust the contrast for the screen so that the title is brighter than the other characters. You need to distinguish highlighted characters during the customizing procedures.

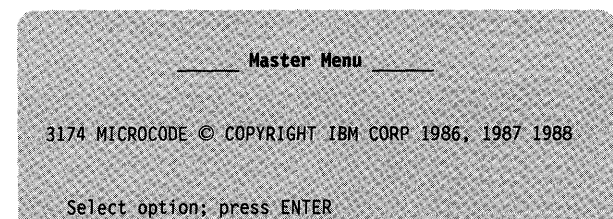

9

Turn on a printer if you want to print copies of the customization panels as you complete them (see Chapter 2, "Keeping Records"). This printer can be attached to any port except port 0.

10

Check the keyboard. It must be a Typewriter, Data Entry, APL (with APL off), or Text (with Text off) QWERTY layout. See Appendix B, "Keyboard and Keypad Layouts" for examples. If the keyboard is not a QWERTY layout, you must select the Identify Customizing Keyboard procedure first from the Master Menu. If you are recustomizing a disk, see Chapter 19, "How to Identify Customizing Keyboards."

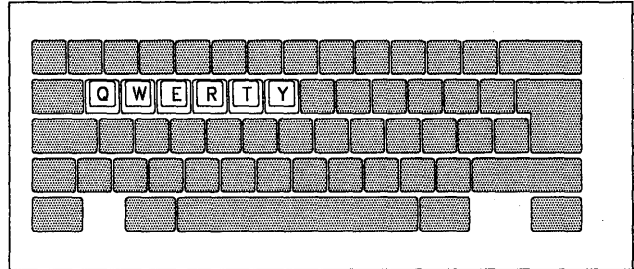

Now you are ready to select a customizing option from the Master Menu. Turn to the procedure for each option.

Procedure	Go to
Customize the Control Disk <ul style="list-style-type: none"> • Configure • Define PAM • Merge RPQs • Modify Keyboards • AEA Configure 	Chapter 13
Merge DSL	Chapter 14
Copy Files	Chapter 15
Microcode Upgrade	Chapter 16
Encrypt/Decrypt	Chapter 17
Media Management	Chapter 18
Identify Customizing Keyboard	Chapter 19
Central Site Customizing	<i>Central Site Customizing User's Guide, GA23-0342.</i>

How to Display the Master Menu – Model 1L

Warning: This procedure interrupts all host services. Notify users if necessary.

1

Turn on the *customizing display station*. (See the documentation that accompanies your display unit, if necessary.)

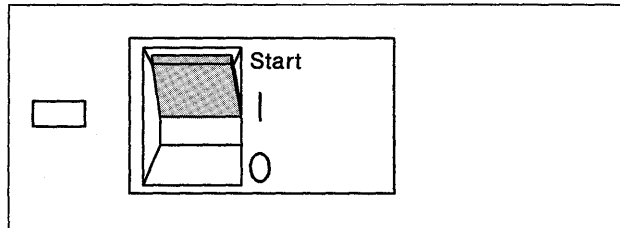

If IMLing from a **diskette drive**, continue with step 2.

If IMLing from a **fixed disk drive**:

- Go to step 3 if the control unit is turned *on* (the green light on the power panel is on).
- Go to step 4 if the control unit is turned *off* (the green light on the power panel is off).

2

Open diskette drive 1 and insert a Utility diskette into the drive. Close the diskette drive.

- Continue with step 3 if the control unit is turned *on* (the green light on the power panel is on).
- Go to step 4 if the control unit is turned *off* (the green light on the power panel is off).

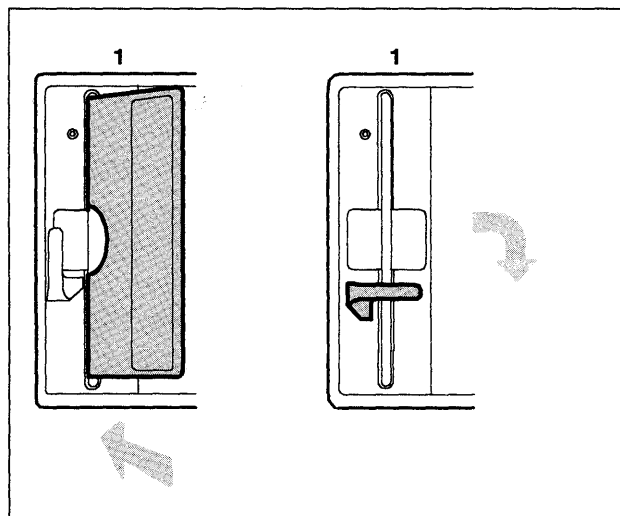

3

The 3174 is turned *on*:

1. Ensure that the Channel Interface switch on the operator panel is in the Offline position. The offline indicator should be lighted. If the indicator does not light in a reasonable time, you may need to ask the system operator to take the control unit offline.
2. Press and hold the Alt 1 pushbutton on the operator panel.
3. While holding the Alt 1 pushbutton, press and release the IML pushbutton.

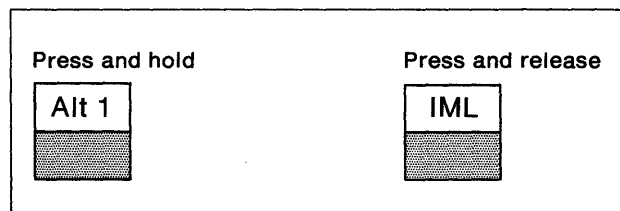
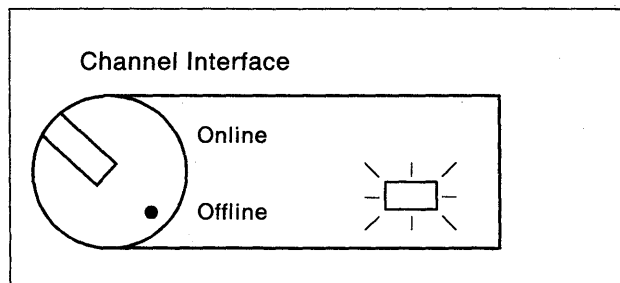

Go to step 5.

4

The 3174 is turned off.

1. Ensure that the Channel Interface switch on the operator panel is in the Offline position and that the offline indicator is lighted.
2. Turn the Power Control switch to the Local position.
3. Press and hold the Alt 1 pushbutton on the operator panel.
4. While holding the Alt 1 pushbutton, lift the On/Off switch on the power panel to Start and release. It will rest in the on (I) position.

Continue to step 5.

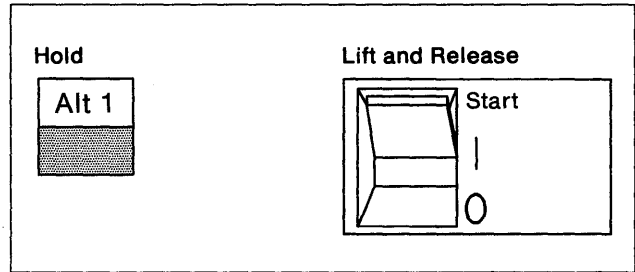
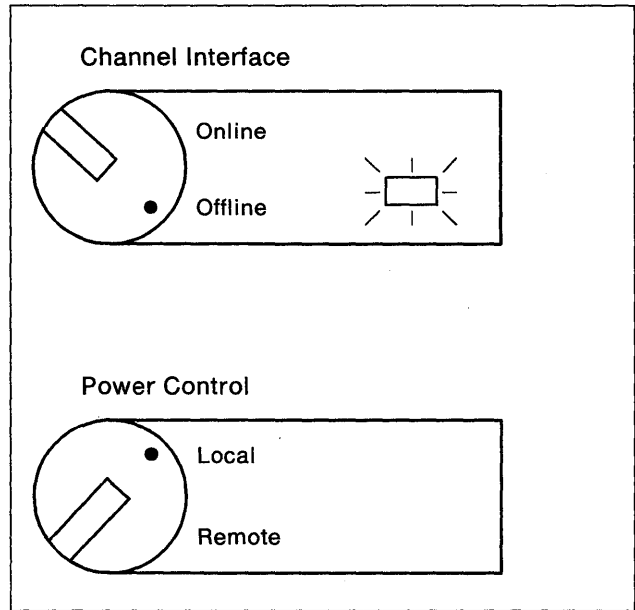

5

When you see 31 in the status indicators, release the Alt 1 pushbutton.

If the correct numbers do not appear, see *3174 Status Codes, GA27-3832*.

If you are IMLing from a **diskette**, continue with step 6.

If you are IMLing from a **fixed disk**, go to step 7.

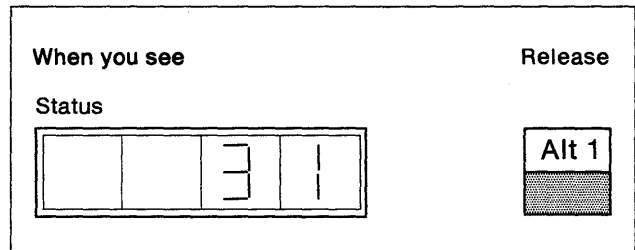

6

If IMLing from a **diskette**: when you see 40 in the status indicators, press and release the ENTER pushbutton on the operator panel. Wait for 7000 to appear in the status indicators.

Go to step 8.

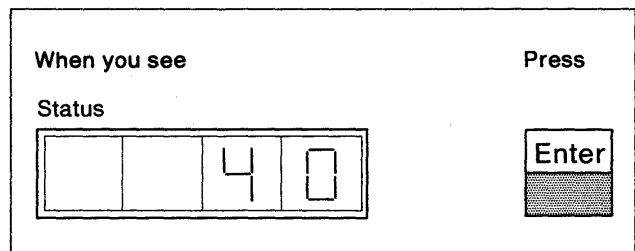

How to Display the Master Menu

7

If IMLing from a **fixed disk** (the fixed disk must contain the Utility microcode):

1. When you see 40 in the status indicators, type in (using the operator's keyboard on the control unit), **0340** to IML from fixed disk 3 or **0440** to IML from fixed disk 4.
2. Press and release the ENTER pushbutton on the operator panel.

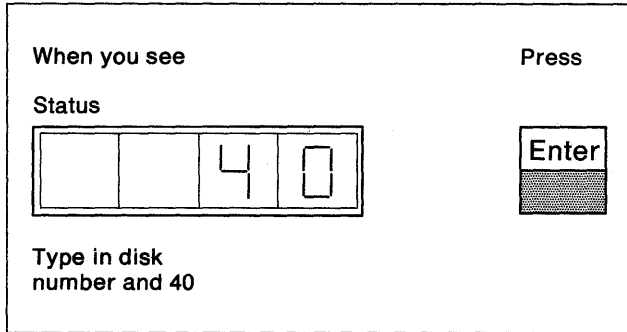

8

In a few moments the Master Menu panel appears on the display screen. The title "Master Menu" should be highlighted. If it is not, adjust the contrast for the screen so that the title is brighter than the other characters. You need to distinguish highlighted characters during the customizing procedures.

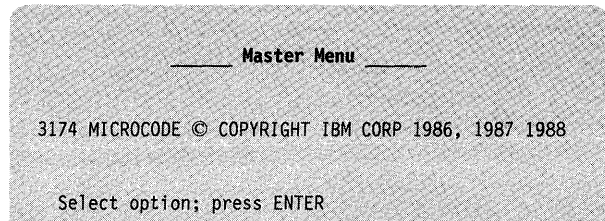

9

Turn on a printer if you want to print copies of the customization panels as you complete them (see Chapter 2, "Keeping Records"). This printer can be attached to any port except port 0.

10

Check the keyboard. It must be a Typewriter, Data Entry, APL (with APL off), or Text (with Text off) QWERTY layout. See Appendix B, "Keyboard and Keypad Layouts" for examples. If the keyboard is not a QWERTY layout, you must select the Identify Customizing Keyboard procedure first from the Master Menu. See Chapter 19, "How to Identify Customizing Keyboards."

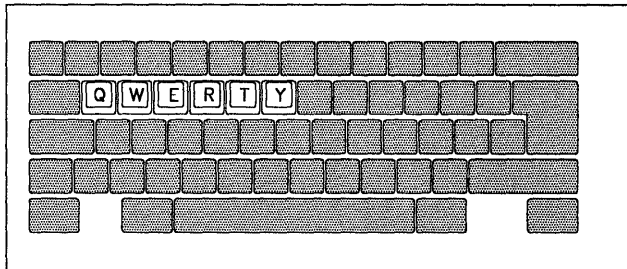

Now you are ready to select a customizing option from the Master Menu. Turn to the procedure for each option.

Procedure	Go to
Customize the Control Disk <ul style="list-style-type: none">• Configure• Define PAM• Merge RPQs• Modify Keyboards• AEA Configure	Chapter 13
Merge DSL	Chapter 14
Copy Files	Chapter 15
Microcode Upgrade	Chapter 16
Encrypt/Decrypt	Chapter 17
Media Management	Chapter 18
Identify Customizing Keyboard	Chapter 19
Central Site Customizing	<i>Central Site Customizing User's Guide, GA23-0342.</i>

Chapter 13. How to Customize the Control Disk

Customize the Control Disk Overview	13-3
Typing in Responses to the Configuration Questions	13-3
Printing a Local Copy	13-3
Correcting Invalid Responses	13-4
Getting Ready to Customize the Control Disk	13-5
PF Keys	13-5
Step 1. Select 'Customize the Control Disk' on the Master Menu	13-6
Step 2. Verify Drives	13-6
Step 3. Select a Customizing Procedure	13-8
Configure Overview	13-9
How to Configure the Control Disk	13-10
Getting Ready to Configure the Control Disk	13-10
PF Keys	13-10
Step 1. Select 'Configure' on the Customize Control Disk Menu	13-12
Step 2. Enter Responses on the Model/Attach Panel	13-13
Step 3. Enter Responses on the Host Panel	13-14
Step 4. Enter Responses on the Token-Ring Network Gateway Panels	13-15
Step 5. Enter Responses on the Common SNA Panel	13-18
Step 6. Enter Responses on the 117: Port Assignment Panel	13-19
Step 7. Enter Responses on the 128: RTM Panel	13-21
Step 8. Enter Responses on the 332: X.25 Options Panel	13-23
Step 9. Press PF12 to Save the Panels	13-24
What's Next?	13-25
How to Define the Printer Authorization Matrix (PAM)	13-26
Getting Ready to Define the PAM	13-26
PF Keys	13-26
Step 1. Select 'Define PAM' on the Customize Control Disk Menu	13-28
Step 2. Enter Responses on the Printer Authorization Matrix Panel(s)	13-29
Step 3. Press PF12 to Save the PAM Panel(s)	13-30
What's Next?	13-30
Merge RPQ Overview	13-31
RPQ Utility Panel	13-31
RPQ Merge Panel	13-33
How to Merge RPQs	13-34
Getting Ready to Merge RPQs	13-34
PF Keys	13-34
Step 1. Select 'Merge RPQ' on the Customize Control Disk Menu	13-35
Step 2. Verify Drives	13-36
Step 3. Select Include, Omit, or Delete Options	13-37
Step 4. Select Merge RPQs Option	13-38
What's Next?	13-39
Modify Keyboards Overview	13-40
How to Modify Keyboards	13-41
Getting Ready to Modify Keyboards	13-41
PF Keys	13-41
Step 1. Fill Out Keyboard Layout Worksheets	13-42
Step 2. Select 'Modify Keyboards' on the Customize Control Disk Menu	13-42
Step 3. Modify the Master Panel	13-43
Step 4. Modify Keyboard Panels	13-46
Step 5. Use the Master Panel to Check Your Results	13-54
Step 6. Exit from the Procedure	13-54
What's Next?	13-55

How to Configure the AEA	13-56
Getting Ready to Configure for the AEA	13-56
PF Keys	13-56
Step 1. Select 'AEA Configure' on the Customize Control Disk Menu ..	13-58
Step 2. Enter Responses on the AEA Configure Panel	13-59
Step 3. Enter Responses on the AEA Port Set Panel	13-60
Step 4. Enter Responses on the AEA Port to Port Set Map Panel	13-61
Step 5. Enter Responses on the AEA Station Set Panels	13-62
Step 6. Enter Responses on the AEA Default Destination Panel	13-64
Step 7. Press PF12 to Save the Panels	13-65
What's Next?	13-66
Step 4. Complete Customizing the Control Disk	13-67
What's Next?	13-68

Customize the Control Disk Overview

This section briefly describes customizing. If you need more information see Chapter 1, "For First-Time Users" and Chapter 2, "Keeping Records." Customizing the control disk consists of entering responses on your customizing display station from worksheets filled out by the customizing planner.

Typing in Responses to the Configuration Questions

Many of the configuration questions have default responses displayed in the response field. A default response is one that is supplied for you, which you can change or leave unchanged. To enter or change a response, use the tab or cursor movement keys to move your cursor to the question and type over the previous response. (The area where you type a response is called the *response field*.)

On the worksheet, many response boxes have a default response printed beneath them. The default responses printed on the worksheet match the default responses displayed on your screen.

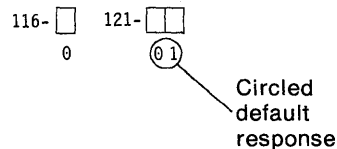

If a response box is left empty and the default response is circled, leave that default response unchanged on the screen. Some questions have Xs displayed in the response field. For the panel to be valid, you *must* type a response to these questions. (You will receive an error message if you do not.)

Printing a Local Copy

One way to keep records of the customization data that you enter during the configuration procedures is to print a local copy of the panel you are currently working on. (Chapter 2, "Keeping Records" describes other methods of record-keeping.) After you have finished entering your responses on a panel, you can print out a copy of it using the following procedure:

1. Turn on a printer that is attached to the control unit.

Note: The printer used for the local copy at customization time must be a coax-attached printer.

2. Press the ENTER key.

The customizing program checks the responses on the panel.

If you get a message indicating an invalid response, see "Correcting Invalid Responses" on page 13-4.

3. Press the PRINT key.

Correcting Invalid Responses

Once responses are entered on the customization panels, the customizing program checks the responses before allowing you to continue to the next panel.

If a response is invalid, the question number and the response are highlighted. A four-digit status code and message displayed on the message line explain why the response is invalid. (See *3174 Status Codes*, GA27-3832, for more information.)

If several questions are highlighted, the status code refers to the questions in numeric order, from higher to lower number. In the case of the 117: Port Assignment panel, all invalid responses of the same type (for example, duplicate addresses) are highlighted at once. After you correct one type of response, another type of invalid response is highlighted.

Use the following procedure to correct any invalid responses.

1. Correct the invalid response to the highest-numbered question or type that is highlighted.
2. Press the ENTER key.

The status code changes to explain the next invalid response. Continue correcting the responses until none are highlighted.

3. A message will indicate when all responses are valid, after the ENTER key is pressed.

Getting Ready to Customize the Control Disk

Selecting this procedure results in the display of a second menu from which you can select the Configure, AEA Configure, Define the PAM, Merge RPQs, and Modify Keyboards procedures.

Before you start, you will need the following:

- The Control disk you want to customize. The Control disk must have *the same microcode level as the Utility disk* that was IMLed. For example, if the Control disk is microcode release level A4.0, the Utility disk must be microcode release level A4.0. For more information, see “How to Determine Maintenance and Microcode Levels” on page 16-4.
- The identity of the customizing keyboard. See Chapter 19, “How to Identify Customizing Keyboards.”
- You may need to see *3174 Status Codes*, GA27-3832.

PF Keys

You call up a specific function of the customizing program by pressing a PF key. As you follow the Customize the Control Disk procedure, your choice of PF keys varies from panel to panel.

Some or all of these PF keys may appear on panels during the Customize the Control Disk procedure:

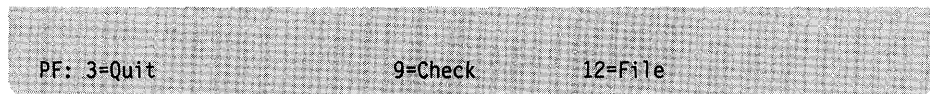

- PF3** PF3 (Quit) is used to quit the procedure. Pressed twice in succession, it erases your responses and returns you to the Master Menu.
- PF9** PF9 (Check) invokes the Interutility Checking panel. For information on how to use the interutility checking function, see Appendix A, “Interutility Checking.”
- PF12** PF12 (File) invokes the Customize Control Disk Completion panel. This initiates a request to have customization responses and merged data transferred from the Utility disk to the Control disk. If you are using a Data Entry, Data Entry Keypunch, or non-QWERTY keyboard without PF12, use the PA2 key.

Note: Keyboards with PF13 through 24 are mapped into PF1 through PF12. For example, PF13 is PF1 and PF15 is PF3.

Now you are ready to customize the Control disk. Turn to page 13-6 and begin the procedure.

How to Customize the Control Disk

Step 1. Select 'Customize the Control Disk' on the Master Menu

1-1: Display the Master Menu (Figure 13-1). (See Chapter 12, "How to Display the Master Menu," for instructions.)

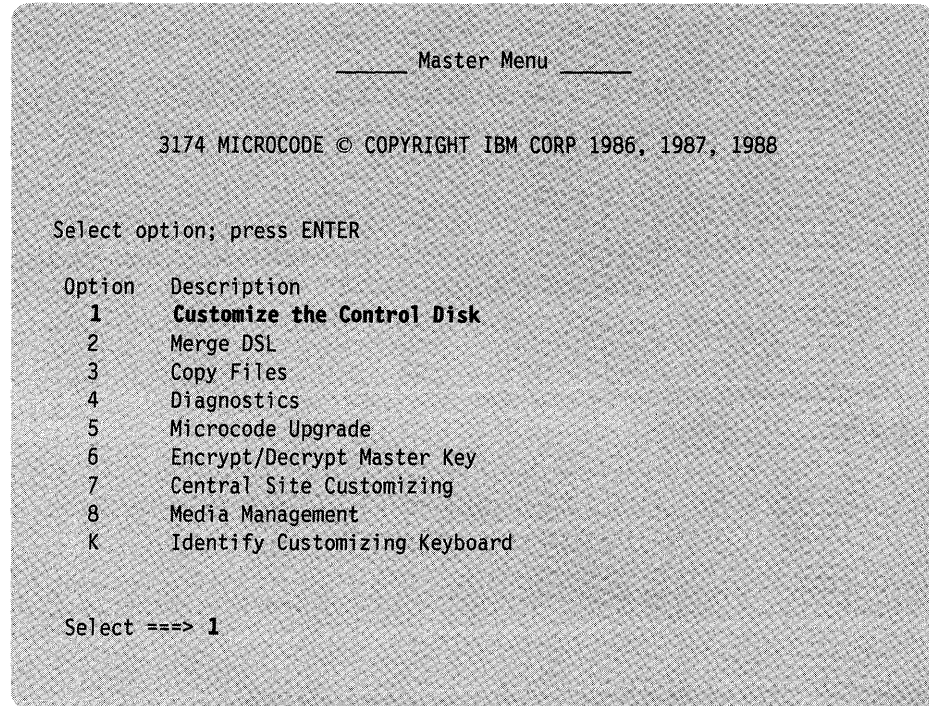

Figure 13-1. The Master Menu

1-2: Type 1 after Select ==>

1-3: Press the ENTER key on the keyboard.

Step 2. Verify Drives

The Disk Drive Assignment panel (Figure 13-2) is displayed on your screen.

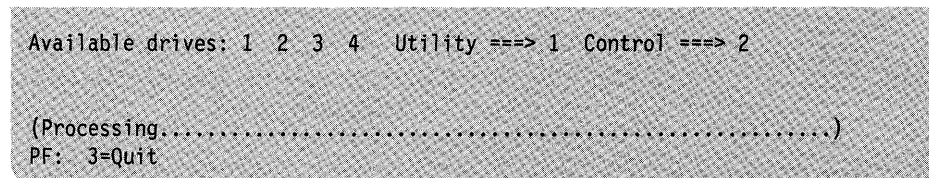

Figure 13-2. Disk Drive Assignment Panel

Figure 13-2 on page 13-6 shows a four-drive (two diskette drives and two fixed disk drives) control unit. Disk drives 1 and 2 are diskette drives and disk drives 3 and 4 are fixed disk drives. The Utility ===> and Control ===> drive fields contain default drive selections (in this example the default drive selections are 1 and 2, respectively). On one-drive control units, drive 1 will be used for both the Control diskette and the Utility diskette.

What happens next depends on the number of drives available on the Control Unit.

For a Control Unit with One Disk Drive

A message to remove the Utility diskette and to insert the Control diskette appears on the message line near the bottom of the screen.

2-1: Insert a Control diskette (at the same microcode level as the Utility diskette you used to display the Master Menu), close the drive lever, and press ENTER. A processing message is displayed.

2-2: After processing is completed, another message will prompt you to remove the Control diskette and to reinsert the **original** Utility diskette.

2-3: Insert the Utility diskette and press ENTER.

Go to step 3.

For a Control Unit with More Than One Disk Drive

2-1: If you do *not* want to use the default drive selection that is displayed on the screen, after Control ===> , type the number of the drive you want to use.

If a **diskette drive** number is displayed after the ===> prompt:

You may be prompted to insert the required diskette(s). Insert any required diskette(s) asked for by the prompt. A message is displayed to indicate that data is being transferred from the Control disk to the Utility disk.

Go to step 3.

If a **fixed disk drive** number is displayed after the ===> prompt:

A processing message is displayed to indicate that data is being transferred from the Control disk to the Utility disk (if the specified Utility or Control disk resides on the fixed disk).

Go to step 3.

Step 3. Select a Customizing Procedure

The Customize Control Disk Menu (Figure 13-3) is displayed. From this panel, you can select an option by typing in the number of the option in the select field.

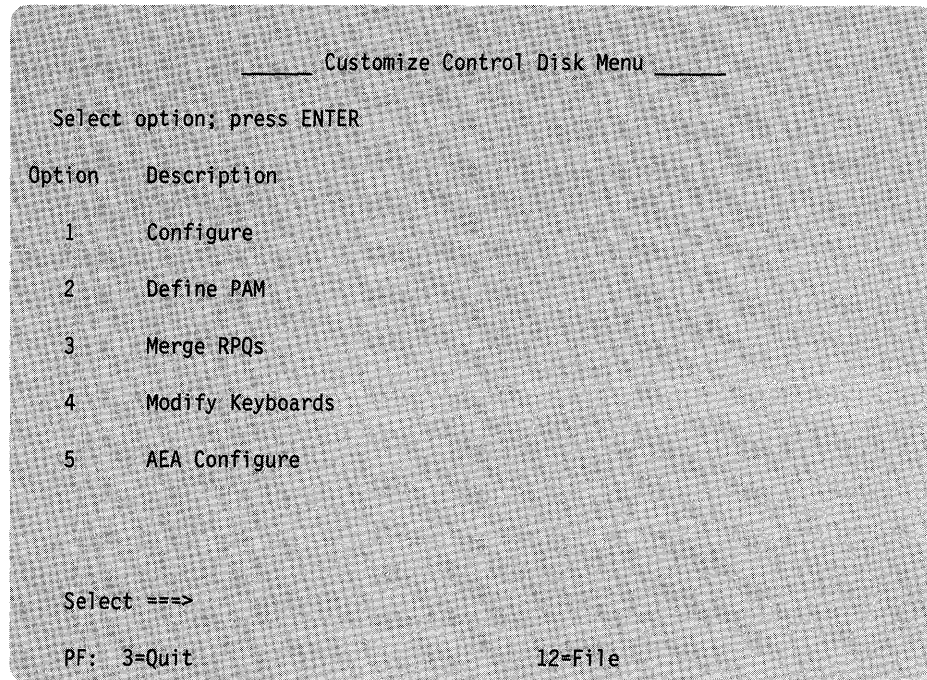

Figure 13-3. Customize Control Disk Menu

After the ENTER key is pressed, the first panel for the option you selected will appear on your screen. Use the following table to locate the procedure for the option you want.

After you exit any of the procedures in the following table, you will be returned to the Customize Control Disk Menu panel.

Warning: When you have completed the customizing procedure(s), the responses you made must be transferred from the Utility disk to the Control disk, or they will not be saved. To transfer your responses, see “Step 4. Complete Customizing the Control Disk” on page 13-67.

If you want to	Go to page
Configure/Reconfigure	13-9
Define/Redefine the PAM	13-26
Merge RPQs	13-31
Modify Keyboards	13-40
Configure/Reconfigure AEA	13-56

Configure Overview

This procedure allows you to type in the responses to the numbered questions on the configuration worksheets or change responses to a previous configuration. It is recommended that you go back through the planning process before reconfiguring.

How you respond to certain configuration questions during the Configure procedure determines which panels will appear. For instance, a response of 2, 3, 5, 6, or 7 to question 101-Host attachment will cause the Common SNA Panel to appear. Figure 13-4 provides an overview of the panel sequence that can appear during the Configure procedure.

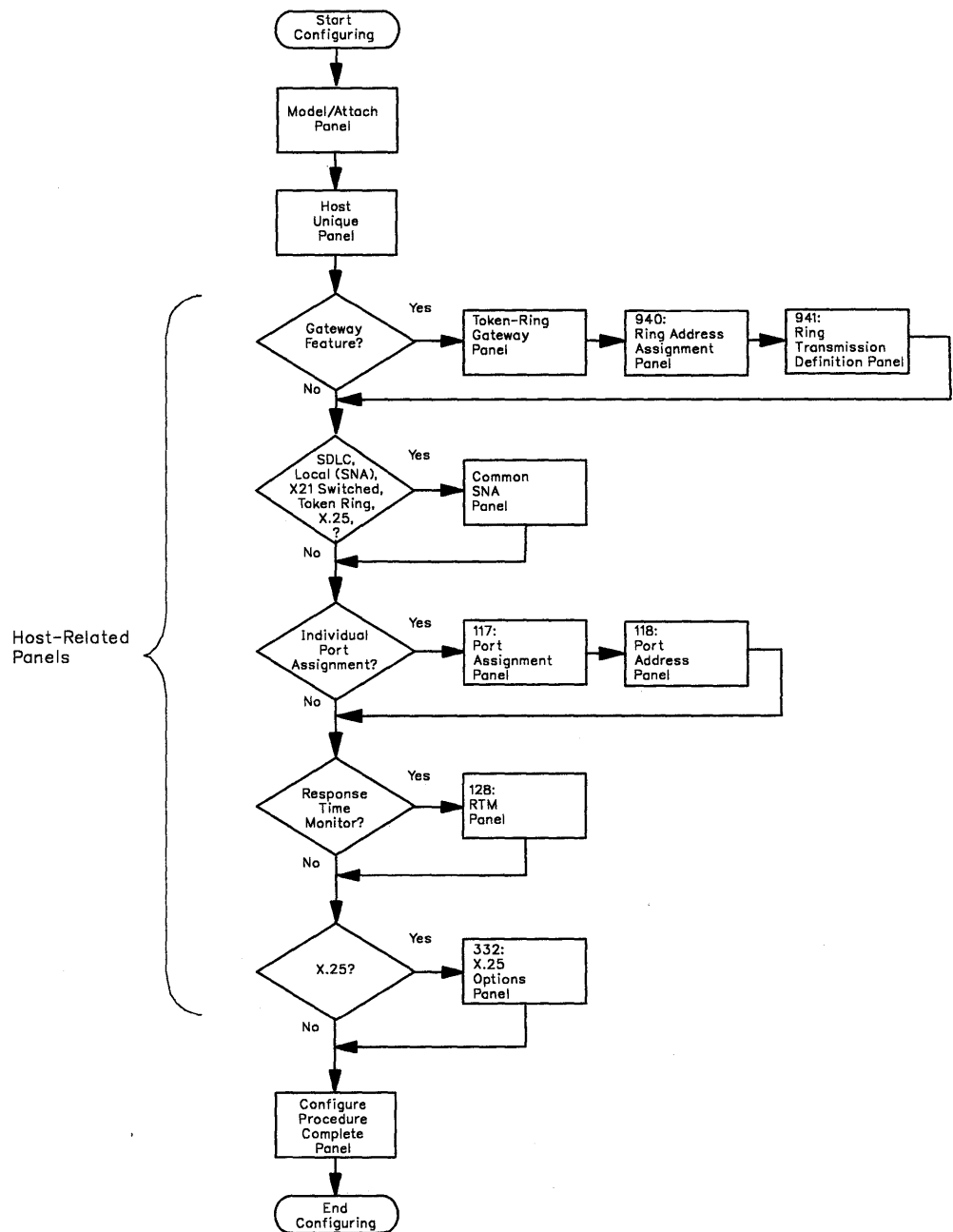

Figure 13-4. Configure Panel Sequence

How to Configure the Control Disk

Before you perform this procedure, you must have selected the “Customize the Control Disk” option from the Master Menu and verified the disk drives; if you have not done this, see “Step 1. Select ‘Customize the Control Disk’ on the Master Menu” on page 13-6.

Getting Ready to Configure the Control Disk

Before you start, you will need the following:

- The configuration worksheets with the responses written on them
- You may need to see *3174 Status Codes*, GA27-3832.

PF Keys

You call up a specific function of the customizing program by pressing a PF key. As you follow the Configure procedure, your choice of PF keys varies from panel to panel.

Some or all of these PF keys may appear on panels during the Configure procedure:

PF:3=Quit 4=Default 7=Back 8=Fwd 9=RtnH 10=PgBack 11=PgFwd 12=Done

PF3 PF3 (Quit) is used to quit the procedure. Pressing it erases all the responses you have entered on all the previous panels. Then the Customize Control Disk Menu appears on your screen.

PF4 PF4 (Default) erases your responses from the current panel on your screen. The screen clears, and the same panel, filled with default responses, reappears.

While the Token-Ring Gateway panels (940 and 941) are displayed, pressing PF4 once, causes a message to appear on the message line. The message prompts you to press PF4 a second time to clear the screen.

PF7 PF7 (Back) brings up the previous panel. When you press PF7, the responses you have entered on the current panel are saved temporarily, even if the panel is not completed. When you return to the partially completed panel, you can complete it.

PF8 PF8 (Forward) checks the responses on the current panel for errors, and if there are none, causes the next panel to appear on the screen. If there are any errors, an error message appears on the message line. You cannot advance to the next panel until all errors are corrected. When you press PF8, the responses you have entered on the current panel are saved temporarily, even if the panel is not completed.

PF9 PF9 (Return Host) returns you to the host panel that you completed (titled BSC, SDLC, X.25, X.21 Switched, Local Non-SNA, Local SNA, or Token-Ring Network). When you press PF9, the responses you entered on the current panel are saved temporarily, even if the panel is not completed. After you return to the host panel, press PF8 to advance through the subsequent panels. When you return to the partially completed panel, you can complete it.

Note: If you are using a non-QWERTY keyboard without a PF9, use the attention (ATTN) key.

PF10 Pressed while the Port Assignment panels (117 and 118) are displayed, PF10 (Page Back) pages back to the previous panel to display ports that are not displayed on the current panel.

Pressed while the Token-Ring Gateway panels (940 and 941) are displayed, PF10 pages back to the previous panel.

PF11 Pressed while the Port Assignment panels (117 and 118) are displayed, PF11 (Page Forward) pages forward to the next panel to display ports that are not displayed on the current panel.

Pressed while the Token-Ring Gateway panels (940 and 941) are displayed, PF11 pages forward to the next panel.

PF12 Pressed at the end of the Configure procedure, PF12 (Done) saves all the responses you have entered on all the previous panels onto the Utility disk. Then the Customize Control Disk Menu appears on your screen.

Note: If you are using a Data Entry, Data Entry Keypunch, or non-QWERTY keyboard without PF12, use the PA2 key.

Note: Keyboards with PF13 through 24 are mapped into PF1 through 12. For example, PF13 is PF1 and PF15 is PF3.

Now you are ready to configure. Turn to 13-12 and begin the procedure.

Step 1. Select 'Configure' on the Customize Control Disk Menu

The Customize Control Disk Menu (Figure 13-5) is displayed on your screen.

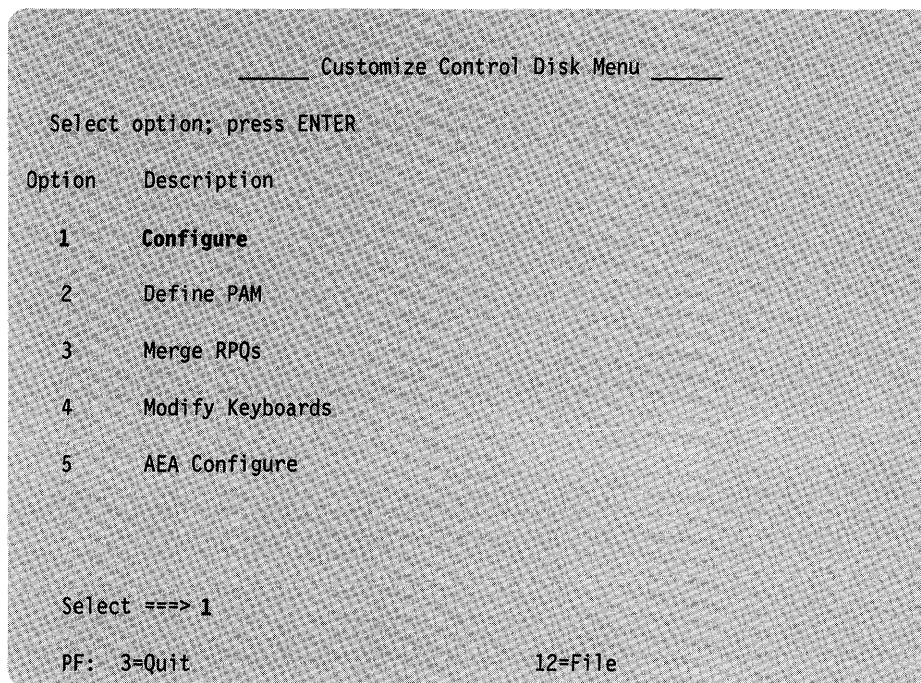

Figure 13-5. Customize Control Disk Menu (select Configure)

1-1: Type **1** after Select ==>

1-2: Press the ENTER key on the keyboard.

After pressing ENTER, the Model/Attach panel (Figure 13-6) appears on your screen.

Step 2. Enter Responses on the Model/Attach Panel

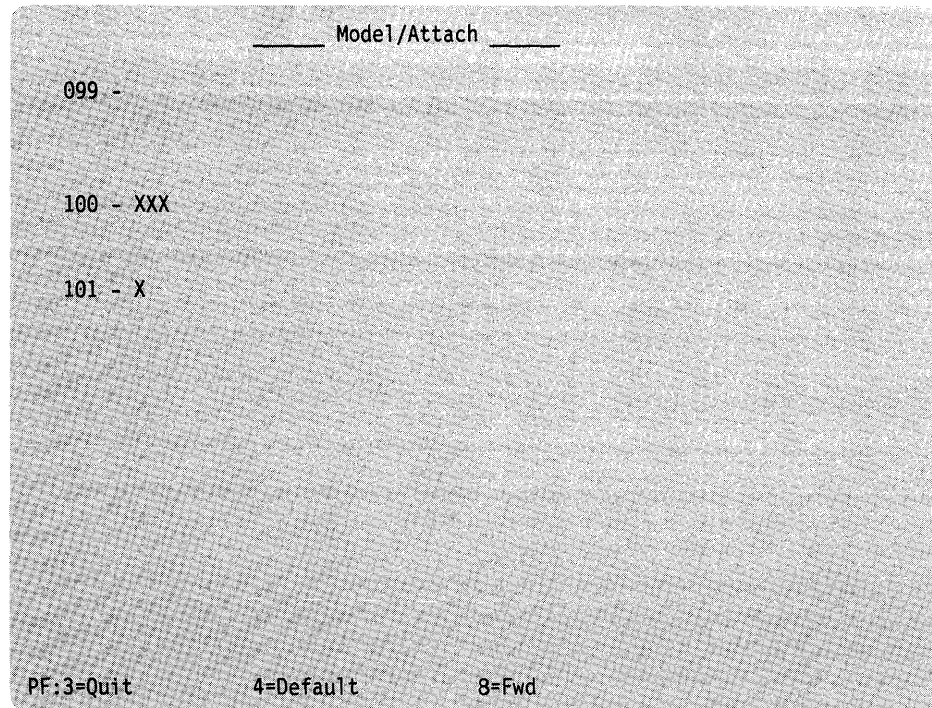

Figure 13-6. Model Attach Panel

2-1: Locate the first configuration worksheet ("Worksheet 1—Host Attachment") and the responses recorded on it.

2-2: Type each response written on the worksheet in the field following the question number.

2-3: If you want a record of the responses you typed in, print a local copy of the panel. (If necessary, see "Printing a Local Copy" on page 13-3.)

2-4: Press PF8 to advance to the next panel.

If you have any invalid responses, you can correct them as described in "Correcting Invalid Responses" on page 13-4. When all the responses are valid, press PF8 to advance to the next panel.

Step 3. Enter Responses on the Host Panel

The Host Panel appears next. Figure 13-7 is an example of a typical Host Panel. Note that this is an example only; the panel you see will differ.

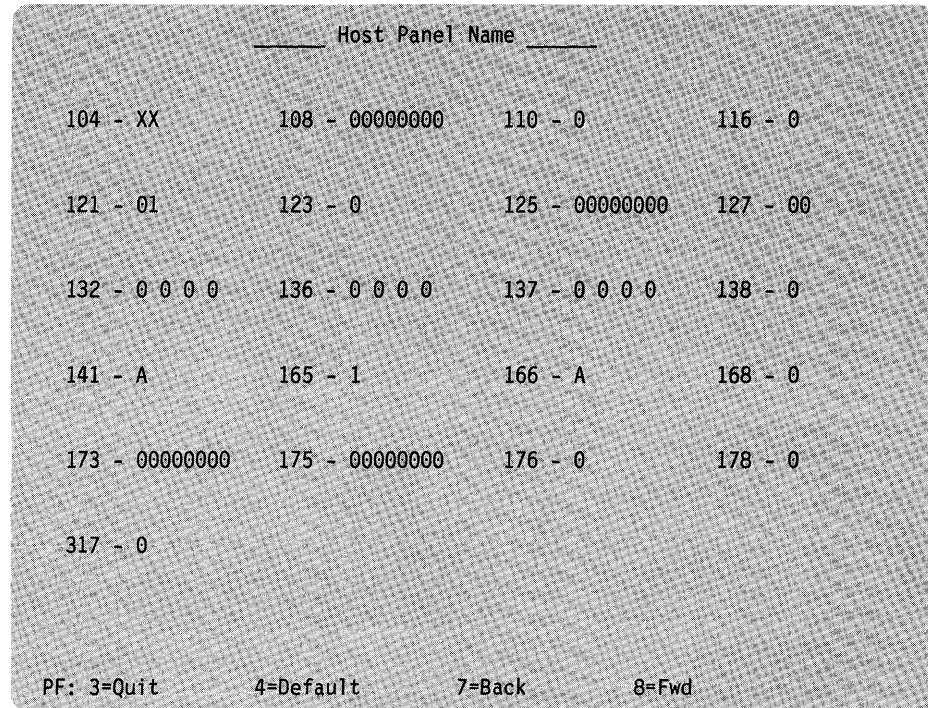

Figure 13-7. Layout of a Typical Host Panel

The title of the panel (BSC, SDLC, X.25, X.21 Switched, Local Non-SNA, Local SNA, or Token-Ring Network) will appear at the top of the panel. The numbers, placement, and amount of questions that appear on the panel will also be different than the panel shown in Figure 13-7.

3-1: Compare the title of the panel on your screen with the title of the configuration worksheet that has responses recorded on it. (If the titles do not match, the person who completed "Worksheet 1—Host Attachment" should check the response to question 101. This response determines which host panel is displayed.)

3-2: Type in the responses recorded on the configuration worksheet.

3-3: If you want a record of the responses you typed in, print a local copy of the panel. (If necessary, see "Printing a Local Copy" on page 13-3.)

3-4: To advance, press PF8. Either a panel or a message appears next:

If the:	Go to:
Token-Ring Gateway panel appears	Step 4 on page 13-15
Common SNA panel appears	Step 5 on page 13-18
117: Port Assignment panel appears	Step 6 on page 13-19
128: RTM panel appears	Step 7 on page 13-21
332: X.25 Options panel appears	Step 8 on page 13-23
Configure Procedure Complete panel appears	Step 9 on page 13-24

If you have any invalid responses, you can correct them as described in “Correcting Invalid Responses” on page 13-4. When all the responses are valid, press PF8 to advance to the next panel.

Step 4. Enter Responses on the Token-Ring Network Gateway Panels

The Token-Ring 3270 Gateway panel (Figure 13-8) appears on your screen if your response to question 101 was either 2 or 5, and if one of the following is true:

- Your response to question 105 was not 00, or
- Your responses to questions 104 and 105 did not match.

The Token-Ring Gateway panel is the first of a series of panels to appear. The 940: Ring Address Assignment panel (Figure 13-9 on page 13-16) appears next, followed by the 941: Ring Transmission Definition panel (Figure 13-10 on page 13-17).

The size of the screen you are using determines how much of the 940: and 941: panels you see. For example, a 3278 Model 2 will show only 24 lines (as shown in Figure 13-9 and Figure 13-10), while a 3278 Model 4 will display 43 lines (the entire panel).

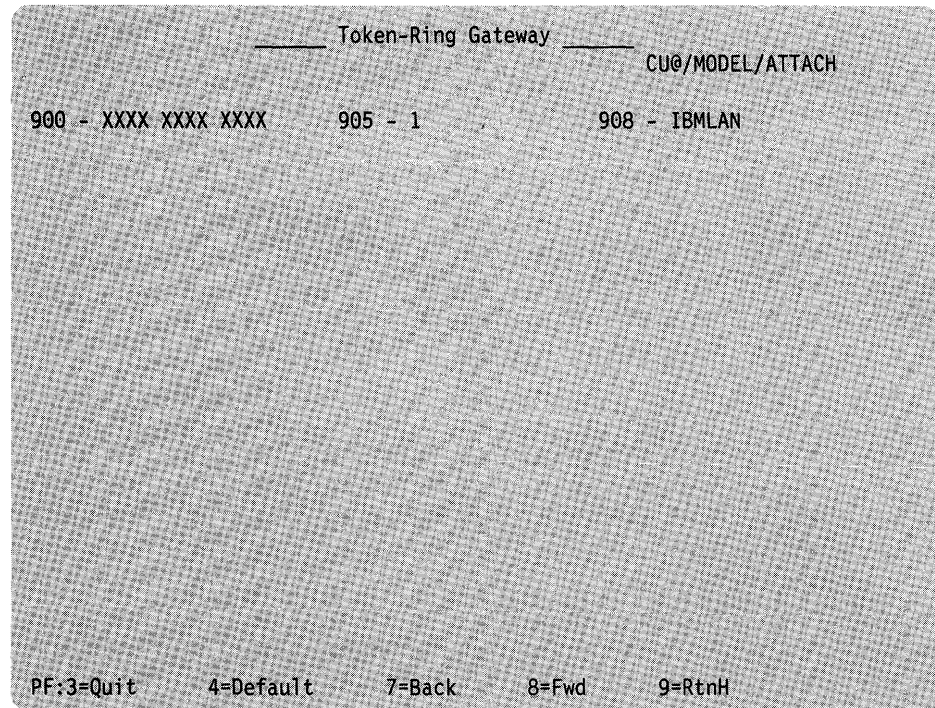

Figure 13-8. Token-Ring Gateway Panel

How to Configure the Control Disk

4-1: Type in the responses recorded on the Token-Ring Gateway Worksheets (Worksheets 9, 10, and 11).

If there is a 1-digit response for a 2-digit field, or a 3-digit response for a 4-digit field, use a leading zero (for example, 02 for 2, or 0356 for 356). *You cannot use blanks.*

4-2: If you want a record of the responses you typed in, print a local copy of the panels. (If necessary, see "Printing a Local Copy" on page 13-3.)

4-3: To advance to the next panel, press PF8.

If you have any invalid responses, you can correct them as described in "Correcting Invalid Responses" on page 13-4. When all the responses are valid, press PF8 to advance to the next panel.

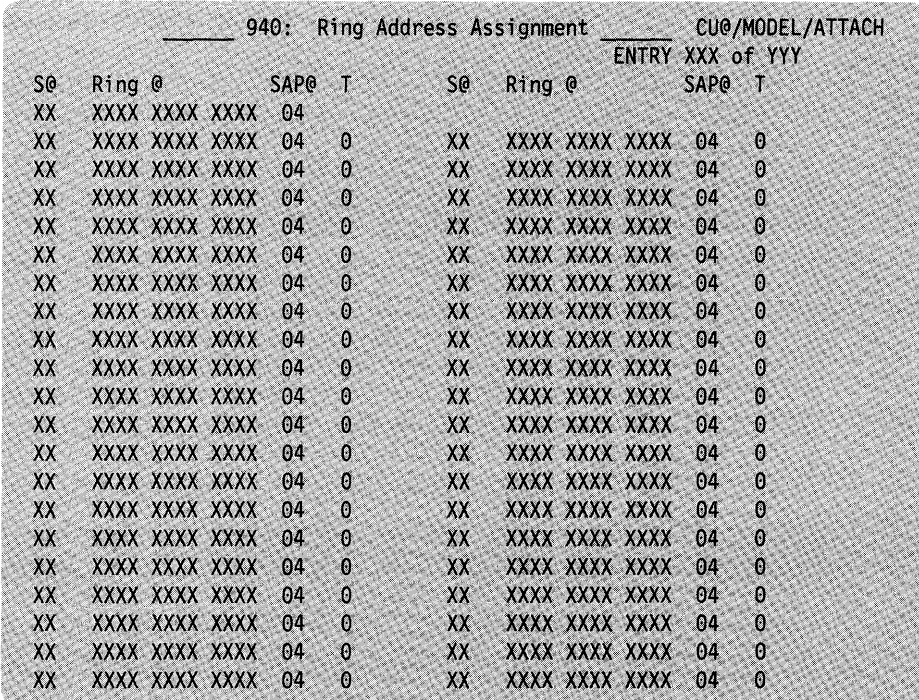

940: Ring Address Assignment CU@/MODEL/ATTACH

ENTRY				XXX of YYY			
S@	Ring @	SAP@	T	S@	Ring @	SAP@	T
XX	XXXX XXXX XXXX	04					
XX	XXXX XXXX XXXX	04	0	XX	XXXX XXXX XXXX	04	0
XX	XXXX XXXX XXXX	04	0	XX	XXXX XXXX XXXX	04	0
XX	XXXX XXXX XXXX	04	0	XX	XXXX XXXX XXXX	04	0
XX	XXXX XXXX XXXX	04	0	XX	XXXX XXXX XXXX	04	0
XX	XXXX XXXX XXXX	04	0	XX	XXXX XXXX XXXX	04	0
XX	XXXX XXXX XXXX	04	0	XX	XXXX XXXX XXXX	04	0
XX	XXXX XXXX XXXX	04	0	XX	XXXX XXXX XXXX	04	0
XX	XXXX XXXX XXXX	04	0	XX	XXXX XXXX XXXX	04	0
XX	XXXX XXXX XXXX	04	0	XX	XXXX XXXX XXXX	04	0
XX	XXXX XXXX XXXX	04	0	XX	XXXX XXXX XXXX	04	0
XX	XXXX XXXX XXXX	04	0	XX	XXXX XXXX XXXX	04	0
XX	XXXX XXXX XXXX	04	0	XX	XXXX XXXX XXXX	04	0
XX	XXXX XXXX XXXX	04	0	XX	XXXX XXXX XXXX	04	0
XX	XXXX XXXX XXXX	04	0	XX	XXXX XXXX XXXX	04	0
XX	XXXX XXXX XXXX	04	0	XX	XXXX XXXX XXXX	04	0
XX	XXXX XXXX XXXX	04	0	XX	XXXX XXXX XXXX	04	0
XX	XXXX XXXX XXXX	04	0	XX	XXXX XXXX XXXX	04	0
XX	XXXX XXXX XXXX	04	0	XX	XXXX XXXX XXXX	04	0
XX	XXXX XXXX XXXX	04	0	XX	XXXX XXXX XXXX	04	0
XX	XXXX XXXX XXXX	04	0	XX	XXXX XXXX XXXX	04	0
XX	XXXX XXXX XXXX	04	0	XX	XXXX XXXX XXXX	04	0
XX	XXXX XXXX XXXX	04	0	XX	XXXX XXXX XXXX	04	0
XX	XXXX XXXX XXXX	04	0	XX	XXXX XXXX XXXX	04	0
XX	XXXX XXXX XXXX	04	0	XX	XXXX XXXX XXXX	04	0

Figure 13-9. 940: Ring Address Assignment Panel (24 lines displayed)

941: Ring Transmission Definition CU@/MODEL/ATTACH

ENTRY XXX of YYY

S@	Ring @	SAP@	F	W	S@	Ring @	SAP@	F	W
XX	XXXX XXXX XXXX	04			XX	XXXX XXXX XXXX			
XX	XXXX XXXX XXXX	04			XX	XXXX XXXX XXXX	04		
XX	XXXX XXXX XXXX	04			XX	XXXX XXXX XXXX	04		
XX	XXXX XXXX XXXX	04			XX	XXXX XXXX XXXX	04		
XX	XXXX XXXX XXXX	04			XX	XXXX XXXX XXXX	04		
XX	XXXX XXXX XXXX	04			XX	XXXX XXXX XXXX	04		
XX	XXXX XXXX XXXX	04			XX	XXXX XXXX XXXX	04		
XX	XXXX XXXX XXXX	04			XX	XXXX XXXX XXXX	04		
XX	XXXX XXXX XXXX	04			XX	XXXX XXXX XXXX	04		
XX	XXXX XXXX XXXX	04			XX	XXXX XXXX XXXX	04		
XX	XXXX XXXX XXXX	04			XX	XXXX XXXX XXXX	04		
XX	XXXX XXXX XXXX	04			XX	XXXX XXXX XXXX	04		
XX	XXXX XXXX XXXX	04			XX	XXXX XXXX XXXX	04		
XX	XXXX XXXX XXXX	04			XX	XXXX XXXX XXXX	04		
XX	XXXX XXXX XXXX	04			XX	XXXX XXXX XXXX	04		
XX	XXXX XXXX XXXX	04			XX	XXXX XXXX XXXX	04		
XX	XXXX XXXX XXXX	04			XX	XXXX XXXX XXXX	04		
XX	XXXX XXXX XXXX	04			XX	XXXX XXXX XXXX	04		
XX	XXXX XXXX XXXX	04			XX	XXXX XXXX XXXX	04		
XX	XXXX XXXX XXXX	04			XX	XXXX XXXX XXXX	04		
XX	XXXX XXXX XXXX	04			XX	XXXX XXXX XXXX	04		
XX	XXXX XXXX XXXX	04			XX	XXXX XXXX XXXX	04		
XX	XXXX XXXX XXXX	04			XX	XXXX XXXX XXXX	04		
XX	XXXX XXXX XXXX	04			XX	XXXX XXXX XXXX	04		

Figure 13-10. 941: Ring Transmission Definition Panel (24 lines displayed). The F and W fields will contain defaults that depend on the response to the T (type) field specified in the 940: Ring Address Assignment panel.

Step 5. Enter Responses on the Common SNA Panel

The common SNA panel (Figure 13-11) appears if your response to question 101 was: 2 - SDLC, 3 - X.25, 5 - Local SNA, 6 - X.21, or 7 - Token-Ring Network.

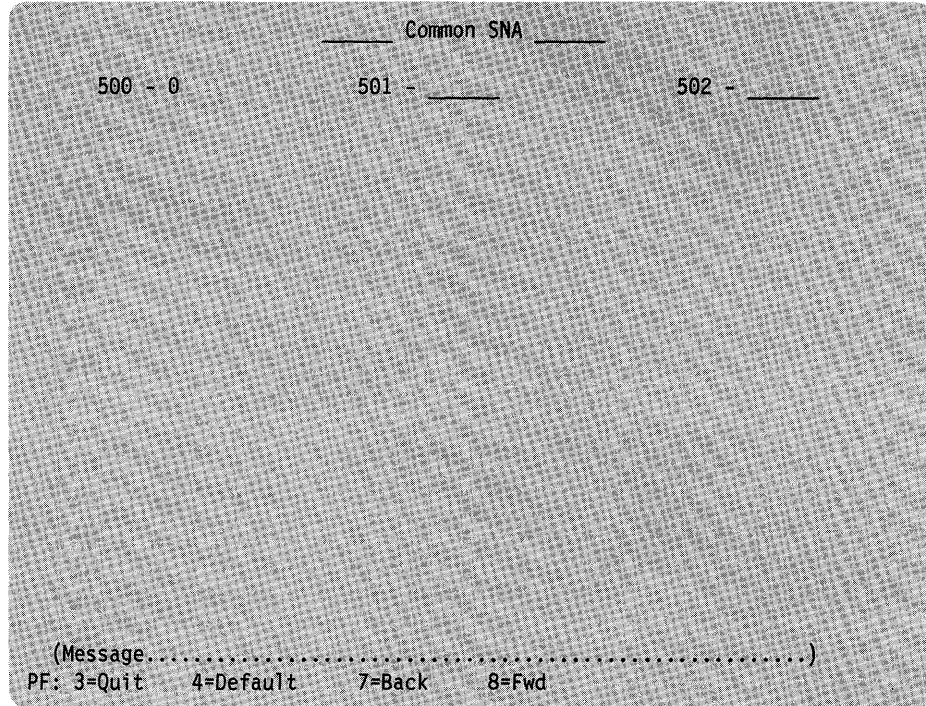

Figure 13-11. Common SNA Panel

5-1: Type in the responses recorded on "Worksheet 24—Common SNA."

5-2: If you want a record of the responses you typed in, print a local copy of the panel. (If necessary, see "Printing a Local Copy" on page 13-3.)

5-3: Press PF8 to advance to the next panel. Either a panel or a message appears next:

If the:	Go to:
117: Port Assignment panel appears	Step 6 on page 13-19
128: RTM panel appears	Step 7 on page 13-21
332: X.25 Options panel appears	Step 8 on page 13-23
Configure Procedure Complete panel appears	Step 9 on page 13-24

If you have any invalid responses, you can correct them as described in "Correcting Invalid Responses" on page 13-4. When all the responses are valid, press PF8 to advance to the next panel.

Step 6. Enter Responses on the 117: Port Assignment Panel

The 117 panel (Figure 13-12) appears on your screen if your response to question 116 on the host panel was 1 or 2. (The response to 166 appears in the 116 = n field at the top of the panel.)

The size of the screen you are using to customize will determine how much of the panel you see. For example, a 3278 Model 2 will show only 24 lines as shown in Figure 13-12, while a 3278 Model 4 will display 43 lines (the entire panel).

117: Port Assignment

LT=000													
C@	#IS	P	S1	S2	S3	S4	C@	#IS	P	S1	S2	S3	S4
26-00	1						26-01	0					
26-02	0						26-03	0					
26-04	0						26-05	0					
26-06	0						26-07	0					
26-08	0						26-09	0					
26-10	0						26-11	0					
26-12	0						26-13	0					
26-14	0						26-15	0					
26-16	0						26-17	0					
26-18	0						26-19	0					
26-20	0						26-21	0					
26-22	0						26-23	0					
26-24	0						26-25	0					
26-26	0						26-27	0					
26-28	0						26-29	0					
26-30	0						26-31	0					
21-00	0						21-01	0					
21-02	0						21-03	0					
21-04	0						21-05	0					
21-06	0						21-07	0					

Figure 13-12. 117: Port Assignment Panel (24 lines displayed)

6-1: Locate the responses recorded on “Worksheet 15—Printer Authorization Matrix (PAM).”

6-2: Type in any responses recorded on the worksheet.

- **#IS column:**

The #IS columns are preset with a response of 0 or 1. You can change these preset responses by typing over the 1 with the desired value (0, 1, 2, 3, 4, or 5). To generate zeros automatically in the #IS fields for ports with no assignments, press PF4.

- **Address columns (LT1/P, LT2/S1, LT3/S2, LT4/S3, LT5/S4):**

When typing in responses in the address columns, you can enter the digit(s) anywhere in the three-digit response field. You do not need to use leading zeros.

Use PF10 or PF11 to display ports that are not displayed.

How to Configure the Control Disk

6-3: If you want a record of the responses you typed in, print a local copy of the panel. (If necessary, see "Printing a Local Copy" on page 13-3.)

6-4: Press ENTER.

When the ENTER key is pressed, the customizing program checks the responses on the panel.

- If all the responses are valid, the panel reappears completed with new information (Figure 13-13 or Figure 13-14).

117: Port Assignment															
LT=000															
C@	#IS	P	LT1	LT2	LT3	LT4	LT5	C@	#IS	P	LT1	LT2	LT3	LT4	LT5
			S1	S2	S3	S4					S1	S2	S3	S4	
26-00	1							26-01	0						
26-02	1							26-03	0						
26-04	4							26-05	0						

Figure 13-13. 117 Panel When Responses Are Typed in the #IS Column

If you typed valid responses in the #IS column the panel reappears with the primary and secondary addresses (shaded areas) filled in.

117: Port Assignment															
LT=000															
C@	#IS	P	LT1	LT2	LT3	LT4	LT5	C@	#IS	P	LT1	LT2	LT3	LT4	LT5
			S1	S2	S3	S4					S1	S2	S3	S4	
26-00			02					26-01	0						
26-02			03	04				26-03	0						
26-04			06	07	08	09		26-05	0						

Figure 13-14. 117 Panel When Responses Are Typed in the Address Columns

If you typed valid addresses in the address columns, the panel reappears with the #IS fields (shaded areas) filled in.

- If a response on the 117 panel is invalid, it is highlighted. If you need information on correcting invalid responses, see "Correcting Invalid Responses" on page 13-4.

6-5: Press PF8 to advance to the 118: Port Address panel.

If you have any invalid responses, you can correct them as described in "Correcting Invalid Responses" on page 13-4. When all the responses are valid, press PF8 to advance to the 118 panel, which displays the port addresses in hexadecimal. You cannot enter any information on this panel.

If you wish to return to the 117: Port Assignment panel, press PF7. You will not see the responses that were generated by the customizing program. Press ENTER, and the responses the program generated are displayed.

6-6: If you want a copy of the 118 panel, print a local copy. (If necessary, see "Printing a Local Copy" on page 13-3.)

Use PF10 and PF11 to display ports which are not already displayed. (You do not need to press ENTER to check the 118 panel.)

6-7: Press PF8 to advance to the next panel.

Step 7. Enter Responses on the 128: RTM Panel

Version A (Figure 13-15) of the 128 panel appears on the screen if your first-digit response to question 127 was 1 or 2. Version B (Figure 13-16) of the 128 panel appears on the screen if your first-digit response to question 127 was 3, 4, or 5.

If your response to question 127 was zero, go to step 8. (If you want to check the response you typed for question 127, press PF9 to return to the host panel.)

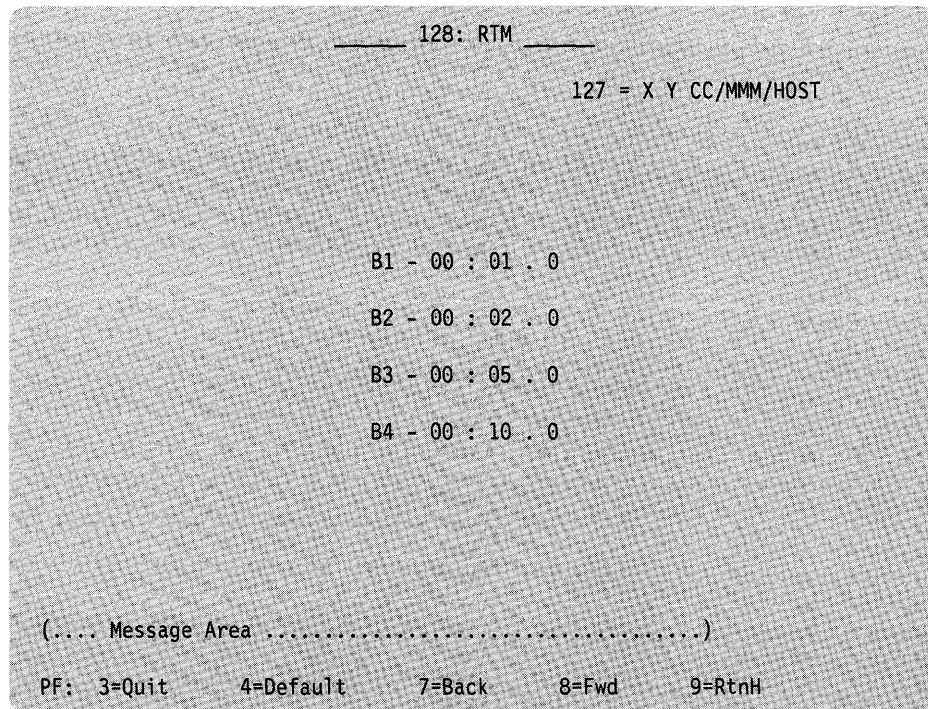

Figure 13-15. Version A of the 128 Panel

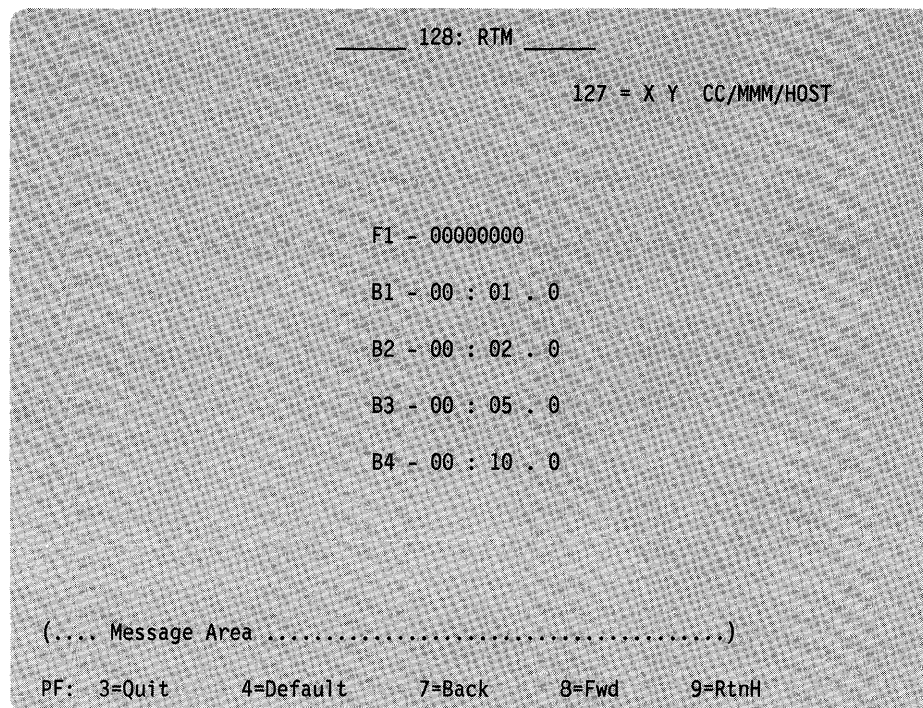

Figure 13-16. Version B of the 128 Panel

7-1: Locate the responses recorded on “Worksheet 13—128: RTM.” The responses are written in *one* of three areas:

- Default Values
- Version A
- Version B.

7-2: Look at the name that is circled on the worksheet.

- If the **Default Values** name is circled, press PF4.
- If **Version A** or **B** is circled, type in the responses recorded on the worksheet.

7-3: If you want a copy of the 128 panel, print a local copy. (If necessary, see “Printing a Local Copy” on page 13-3.)

7-4: Press PF8 to advance to the next panel.

If you have any invalid responses, you can correct them as described in “Correcting Invalid Responses” on page 13-4. When all the responses are valid, press PF8 to advance to the next panel.

Step 8. Enter Responses on the 332: X.25 Options Panel

The 332 panel (Figure 13-17) appears on your screen if your response to question 101 on the Model/Attach panel was 3. If 101 is not equal to 3, go to step 9.

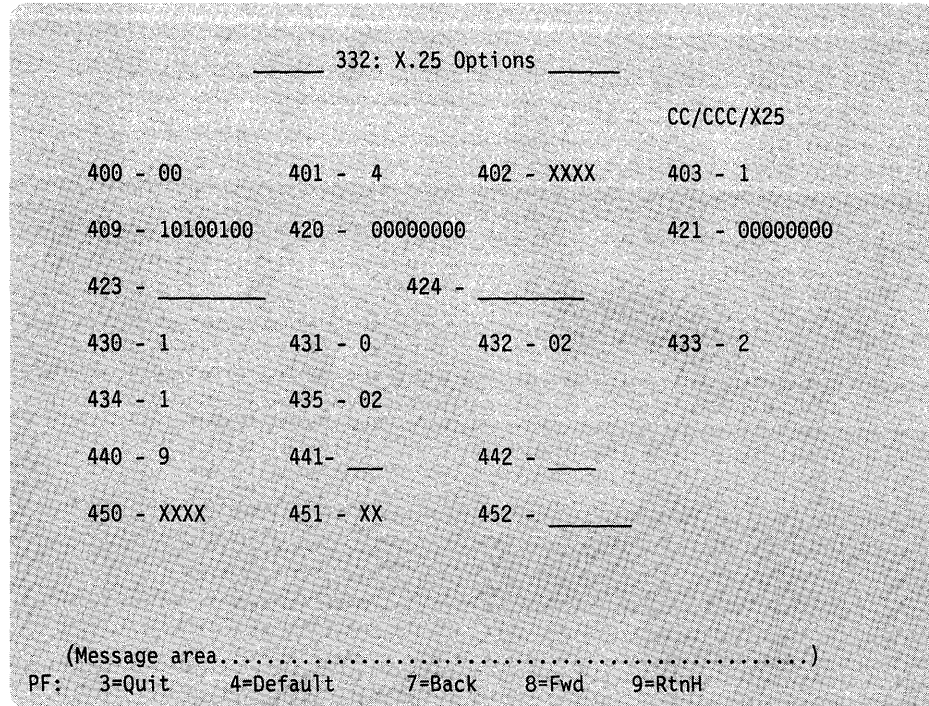

Figure 13-17. 332: X.25 Options Panel

8-1: Type in the responses recorded on “Worksheet 14—X.25 Options.”

If there is a 1-digit response for a 2-digit field, or a 3-digit response for a 4-digit field, use a leading zero (for example, 02 for 2, or 0356 for 356). *You cannot use blanks.*

Note: Responses to questions **423**, **424**, and **452** may not fill the entire field. You may leave underscores wherever you have not typed an alphanumeric character.

8-2: If you want a record of the responses you typed in, print a local copy of the panel. (If necessary, see “Printing a Local Copy” on page 13-3.)

8-3: To advance to the next panel, press PF8.

If you have any invalid responses, you can correct them as described in “Correcting Invalid Responses” on page 13-4. When all the responses are valid, press PF8 to advance to the next panel.

How to Configure the Control Disk

Step 9. Press PF12 to Save the Panels

When all the panels that you need have appeared, the screen clears. A new panel, Configure Complete, appears. See Figure 13-18.

Warning: If you press PF3, all the new configure responses will be erased.

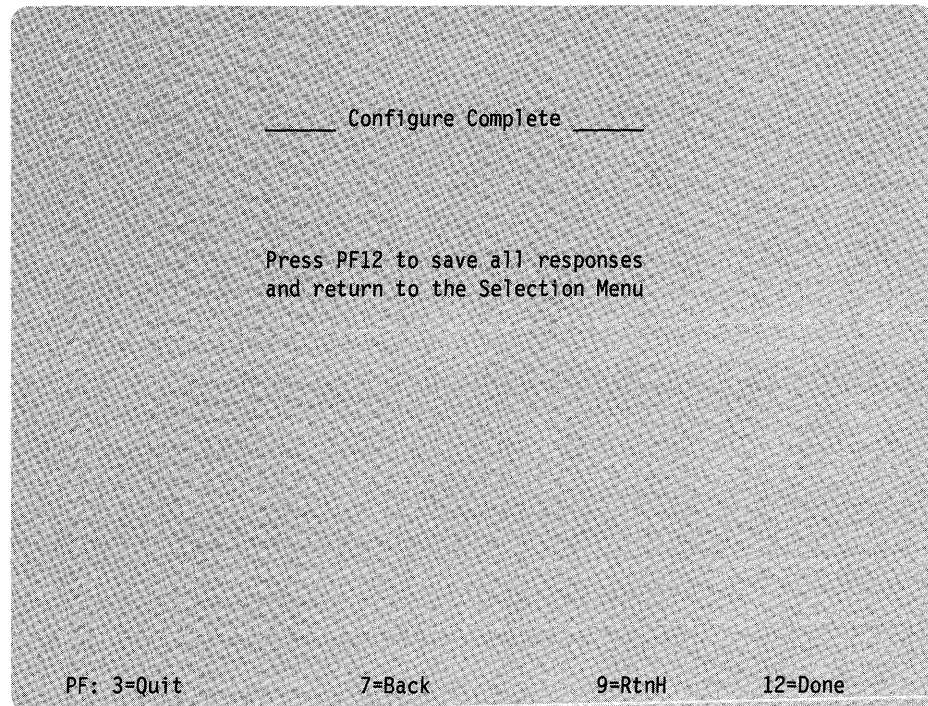

Figure 13-18. Configure Complete Panel

9-1: Press PF12 to permanently save all the panels completed during the Configure procedure.

What's Next?

The Customize Control Disk Menu is on your screen.

You can:

- Complete customizing the Control disk.

Warning: If you have completed customizing the Control disk, the responses you made must be transferred from the Utility disk to the Control disk, or they will not be saved. To transfer these responses, see "Step 4. Complete Customizing the Control Disk" on page 13-67 before returning to the Master Menu.

- Continue to customize the Control disk by selecting another option from the Customize Control Disk Menu.

Use the following table to locate the procedure for the option you want.

If you want to	Go to page
Define/Redefine the PAM	13-26
Merge RPQs	13-31
Modify Keyboards	13-40
Configure/Reconfigure AEA	13-56

How to Define the Printer Authorization Matrix (PAM)

During this procedure, you answer questions that define which displays may use which printers during local copy, host only, and shared operations. This procedure can also be used if you want to change any information entered previously while customizing the Control disk by typing over or deleting any previous responses.

Before you perform this procedure, you must have selected the "Customize the Control Disk" option from the Master Menu and verified the disk drives; if you have not done this, see "Step 1. Select 'Customize the Control Disk' on the Master Menu" on page 13-6.

Getting Ready to Define the PAM

Before you start, you will need the following:

- The Printer Authorization Matrix Worksheet (or worksheets) with responses written on it (or them)
- You may need to see *3174 Status Codes, GA27-3832*.

PF Keys

You call up a specific function of the customizing program when you press a PF key. Some or all of these PF keys may appear on panels during the PAM procedure:

PF: 3=Quit 4=Default 10=Page Back 11=Page Fwd 12=Done

PF3 PF3 (Quit) is used to quit the procedure and erases all the new responses you have entered on the PAM and displays the Master Menu on your screen.

PF4 PF4 (Default) erases the responses from all the PAM panels. The screen clears. The first PAM panel, with printer entries 1–5, appears with no responses entered on it.

PF10 PF10 (Page Back) checks all the panels for errors and pages back to the previous screen while displaying any errors encountered.

Note: If you are using a non-QWERTY keyboard without a PF10 key, use the Cursor Select key.

PF11 PF11 (Page Forward) checks all the panels for errors and pages forward to the next screen while displaying any errors encountered. If you are using a Data Entry, Data Entry Keypunch, or non-QWERTY keyboard without a PF 11, use PA1.

PF12 Pressed at the end of the Define PAM procedure, PF12 (Done) checks all the responses you have entered. When all the responses are valid, PF12 saves the PAM and displays the Customize Control Disk Menu on your screen. If you are using a Data Entry, Data Entry Keypunch, or non-QWERTY keyboard without a PF12, use PA2.

Note: Keyboards with PF13 through 24 are mapped into PF1 through 12. For example, PF13 is PF1 and PF15 is PF3.

Now you are ready to define the PAM. Turn to page 13-28 and begin the procedure.

How to Define the PAM

Step 1. Select 'Define PAM' on the Customize Control Disk Menu

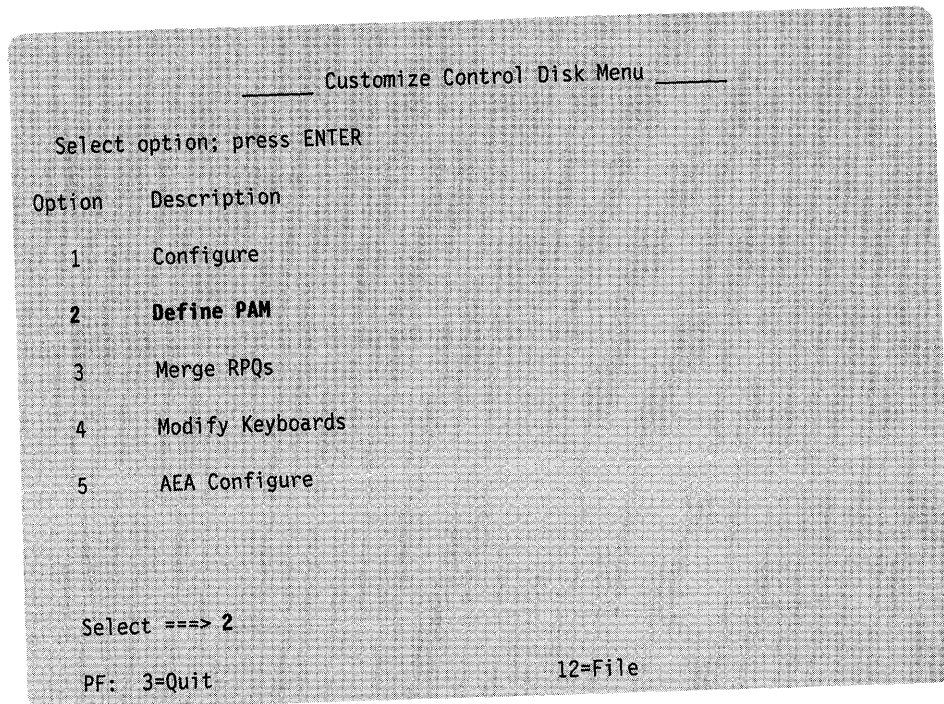

Figure 13-19. Customize Control Disk Menu (select Define PAM)

1-1: Type 2 after Select == >

1-2: Press ENTER on the keyboard.

After pressing ENTER, the PAM Definition Panel (Figure 13-20) appears on your screen.

Step 2. Enter Responses on the Printer Authorization Matrix Panel(s)

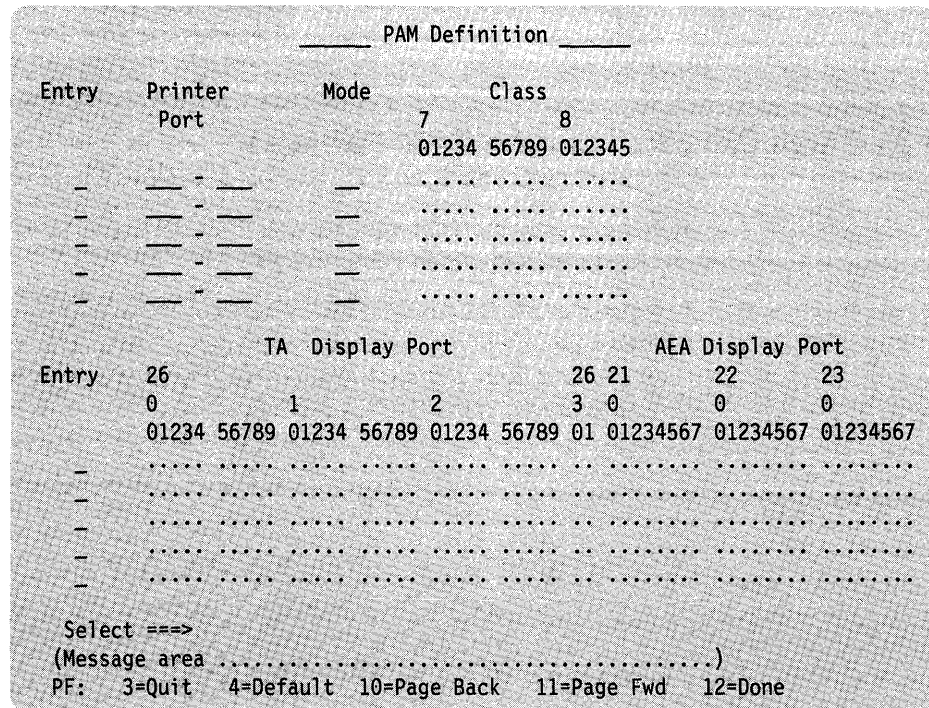

Figure 13-20. Printer Authorization Matrix Definition Panel

2-1: Locate the filled-in “Worksheet 15—Printer Authorization Matrix (PAM).”

2-2: Type the responses on the Printer Authorization Matrix panel displayed on your screen.

Note: If the first two digits of the printer port number (prefix number) are not filled in or are deleted, all the information on the panel that relates to that entry will be deleted after ENTER, PF10, PF11, or PF12 is pressed.

- To advance to the next panel, press PF11.
- To return to a previous panel, press PF10.
- To locate a specific printer entry (for example, entry 16) without having to scroll forward or backward use the LOCATE command. Type L16 in the select field and press ENTER. Entry 16 and the next four entries will appear on your screen. Here are valid ways to type the LOCATE command:
 - Select == > L2_
 - Select == > _L2
 - Select == > L02

Any number between 1 and 47 can be used with the LOCATE command.

Press ENTER.

How to Define the PAM

If you have any invalid responses, you can correct them as described in “Correcting Invalid Responses” on page 13-4.

2-3: If you want a record of the responses you typed in, print a local copy of each PAM panel, after you complete it. (If necessary, see “Printing a Local Copy” on page 13-3.)

Step 3. Press PF12 to Save the PAM Panel(s)

When you have completed your entries, press PF12 to save the PAM panel(s).

- If there are no errors on the PAM, the Customize Control Disk Menu appears on your screen when you press PF12.
- If there are any errors on the PAM, an error message will appear on the message line of the panel currently displayed. You can then move backward or forward among the panels, correcting the highlighted errors. When the errors are corrected, press PF12 again.

What's Next?

The Customize Control Disk Menu is on your screen.

You can:

- Complete customizing the Control disk.
Warning: If you have completed customizing the Control disk, the responses you made must be transferred from the Utility disk to the Control disk, or they will not be saved. To transfer these responses, see “Step 4. Complete Customizing the Control Disk” on page 13-67 before returning to the Master Menu.
- Continue to customize the Control disk by selecting another option from the Customize Control Disk Menu.

Use the following table to locate the procedure for the option you want.

If you want to	Go to page
Configure/Reconfigure	13-9
Merge RPQs	13-31
Modify Keyboards	13-40
Configure/Reconfigure AEA	13-56

Merge RPQ Overview

An RPQ (request for price quotation) is an alteration or addition to the functional capabilities provided by the control unit microcode. An RPQ diskette, purchased from IBM, can contain the microcode for one to 30 RPQs. RPQs are merged to the Utility disk and transferred to the Control disk when PF12 is pressed on the "Customize Control Disk Menu." A maximum of 10 RPQs can reside on a Control disk, regardless of whether they are included or omitted.

The Merge RPQ procedure displays two panels, the RPQ Utility panel and the RPQ Merge panel.

RPQ Utility Panel

On the RPQ Utility panel, you can include, omit, or delete RPQs by typing the number of the option in the field that precedes the RPQ. See Figure 13-21.

```

_____ RPQ Utility _____

1 = Include in IML
2 = Omit from IML
3 = Delete

Utility Disk

1 8K1111.0
2 8K2222.0
3 8K3333.0
- .....
- .....
- .....
- .....
- .....
- .....

RPQ Identifier: _____
RPQ Parameter List:
- - - - -

Available drives: 1 2 3 4 Utility ==> 1 RPQ ==> 2
(Message.....)
PF: 3=Quit 9=Merge 12=Process

```

Figure 13-21. RPQ Utility Panel

Merge RPQ Overview

The RPQ Utility panel tells you how many drives you have available and allows you to verify or select the diskette drive that contains your RPQ diskette. The Utility ===> drive field is defaulted to the drive used for the IML and cannot be altered.

- In a control unit with **one disk drive**,
The Utility ===> and RPQ ===> drive fields are defaulted to 1.
- In a control unit with **more than one disk drive**,
The Utility ===> drive field is defaulted to the IML drive.
The RPQ ===> drive field is defaulted to a diskette drive number.

Note: RPQ diskettes cannot be copied to a fixed disk, but individual RPQs can be merged to the Utility subdirectory (a subdirectory holds the contents of a 3174 diskette) and transferred to the Control subdirectory on the fixed disk by pressing PF12 on the Customize Control Disk Menu. Therefore, only a diskette drive can contain the RPQ diskette.

RPQ Identifier: The RPQ Identifier field (see Figure 13-21 on page 13-31) is optional. The Identifier field provides you with the opportunity to name sets of merged RPQs from a Central Site Library. The name used in the Identifier field should be associated with the merged RPQ data.

The name can contain up to 8 alphanumeric characters (first character must be uppercase alphabetic and no blanks/spaces between characters are allowed). If your location is using Central Site Customizing, you should obtain this name from the person controlling your Central Site Library. See the *Central Site Customizing User's Guide*, GA23-0342, for more information.

See the following examples of valid and invalid names.

Example	
Valid Names:	Invalid Names:
RPQSET1_	1ARPQSET
RPQSET1A	RPQSET 1

RPQ Parameter List Field: The RPQ Parameter List field lists the parameters that a particular RPQ may require. The documentation available with the RPQ describes the parameters the RPQ requires. Duplicate RPQs cannot exist on the same disk. If no data exists in the parameter list of the Utility disk, the field is padded with underscores.

RPQ Merge Panel

The RPQ Merge panel (Figure 13-22) displays the RPQs that exist on an RPQ diskette. As many as 30 RPQs can exist on an RPQ diskette.

On this panel, you can select an RPQ to merge onto the Utility disk by typing a 4 in the field that precedes the RPQ.

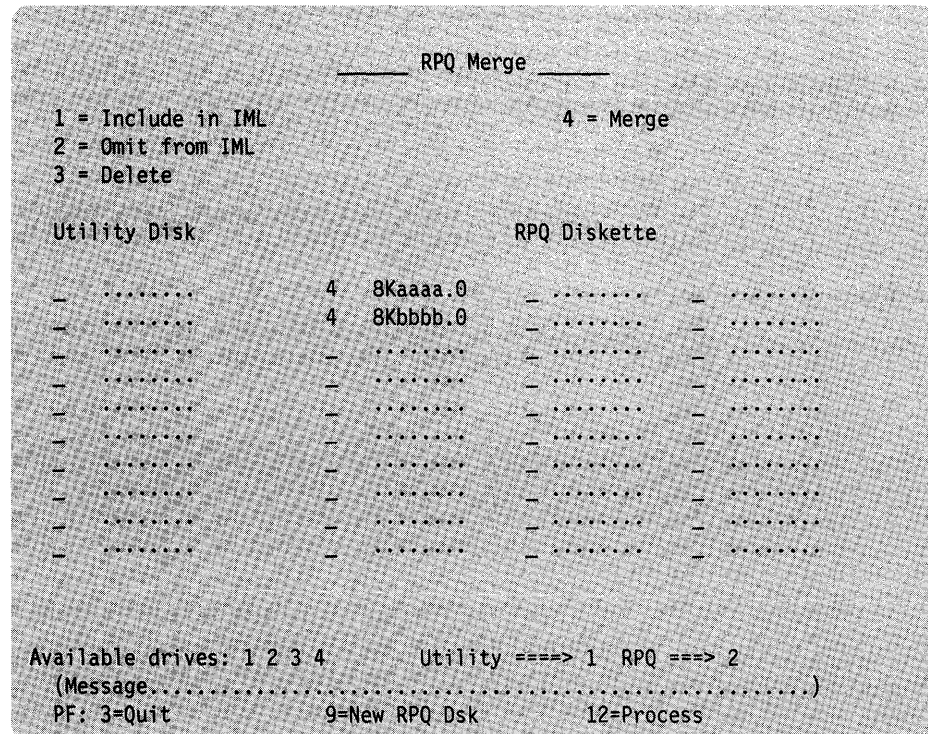

Figure 13-22. RPQ Merge Panel

How to Merge RPQs

To get to this procedure you must select the "Customize Control Disk" option from the Master Menu and verify the disk drives; if you have not done this, see "Step 1. Select 'Customize the Control Disk' on the Master Menu" on page 13-6.

If you must perform a Microcode Upgrade on the Control disk, do it before you perform the Merge RPQs procedure; performing the Microcode Upgrade procedure will erase all the RPQs found on the disk being upgraded.

Getting Ready to Merge RPQs

Before you start, you will need the following:

- RPQ diskette(s).
- You may need to see *3174 Status Codes, GA27-3832*.

PF Keys

You call up a specific function of the customizing program by pressing a PF key. A PF key is operational only if it appears on the panel you are using.

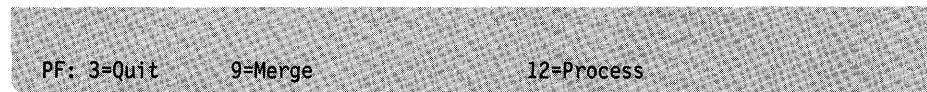

PF3 PF3 (Quit) quits the procedure and erases all the responses you have entered that have not been processed by pressing PF12. When the RPQ Utility panel is on the screen, PF3 displays the Customize Control Disk Menu. When the RPQ Merge panel is on your screen, pressing PF3 once displays the RPQ Utility panel. Pressing PF3 again displays the Customize Control Disk Menu.

PF9 While on the RPQ Utility panel, pressing PF9 (Merge) invokes the RPQ Merge panel. Pressing PF9 (New RPQ Dsk) on the RPQ Merge panel allows you to merge RPQs from any additional disks.

If you are using a non-QWERTY keyboard without a PF9, use the ATTN (Attention) key.

PF12 PF12 (Process) processes the options specified during this procedure. If you are using a Data Entry, Data Entry Keypunch, or non-QWERTY keyboard without PF12, use PA2.

Note: Keyboards with PF13 through 24 are mapped into PF1 through 12. For example, PF13 is PF1 and PF15 is PF3.

Now you are ready to merge RPQs. Turn to page 13-35 and begin the procedure.

Step 1. Select 'Merge RPQ' on the Customize Control Disk Menu

Figure 13-23. Customize Control Disk Menu (select Merge RPQs)

1-1: Type 3 after Select = = = >

1-2: Press ENTER on the keyboard.

After ENTER is pressed, the RPQ Utility panel (Figure 13-24) appears on your screen.

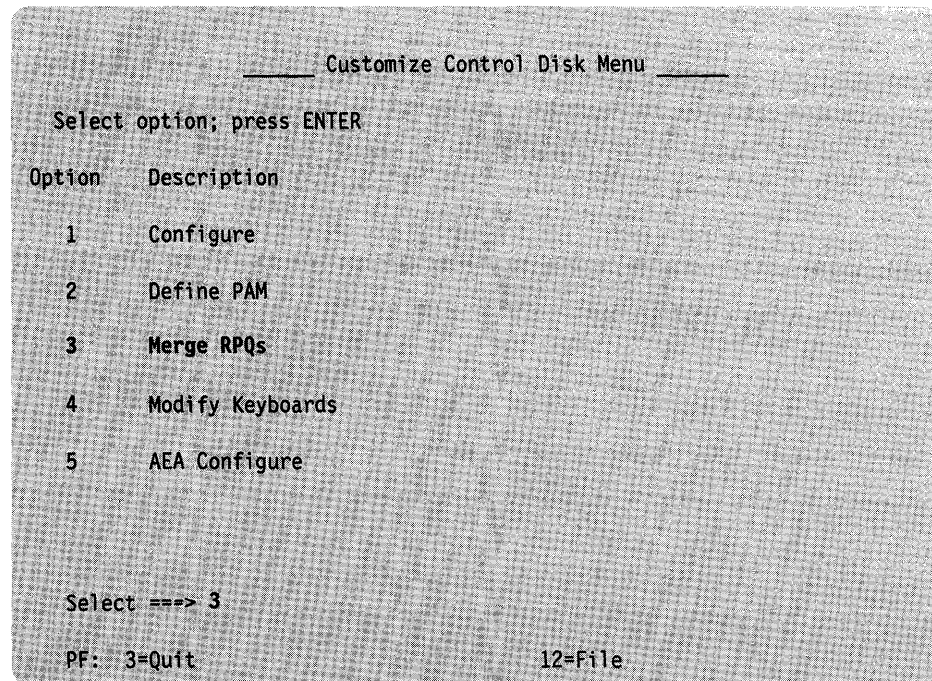
How to Merge RPQs

If any RPQs reside on the Control disk, they are transferred to the Utility disk and are displayed under the Utility disk field.

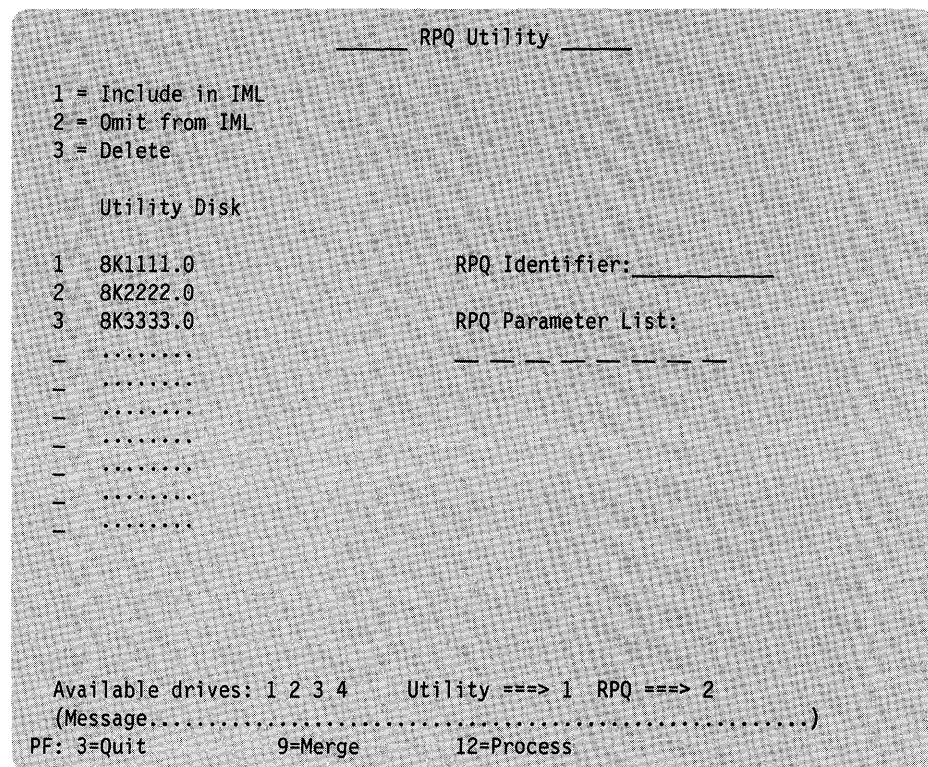

Figure 13-24. RPQ Utility Panel (Merge Procedure)

You may exit this procedure by pressing PF3 or go to the next step.

Step 2. Verify Drives

The RPQ Utility panel (Figure 13-24) with drive selection fields is on your screen. What happens next depends on the number of drives available on the control unit.

For a Control Unit with One Disk Drive

The responses to Utility ==> and RPQ ==> are defaulted to 1.

2-1: Press ENTER.

- To include, omit, or delete RPQs on the Utility diskette, go to “Step 3. Select Include, Omit, or Delete Options” on page 13-37.
- To merge RPQs from an RPQ diskette to the Utility diskette, go to “Step 4. Select Merge RPQs Option” on page 13-38.

For a Control Unit with More Than One Disk Drive

The Utility == => drive field is defaulted to the drive used for the IML and cannot be altered. The RPQ == => drive field is defaulted to a diskette drive. A message prompts you to verify these selections.

If you do not want to use the default drive selection, after RPQ == =>, type the number for the diskette drive you want to use.

2-1: Press ENTER.

2-2: To include, omit, or delete an RPQ from the Utility disk, go to "Step 3. Select Include, Omit, or Delete Options."

2-3: To merge RPQs from an RPQ diskette to a Utility disk, go to "Step 4. Select Merge RPQs Option" on page 13-38.

Step 3. Select Include, Omit, or Delete Options

3-1: To change the option of selected RPQs, move the cursor to the entry you wish to change and type over the displayed value in the option field. Type a **1** to indicate RPQs to be included at IML. Type a **2** to indicate RPQs to be omitted at IML. Type a **3** to indicate RPQs to be deleted.

3-2: If you wish to name this set of merged RPQs, fill in the Identifier field with a valid name (see "RPQ Identifier" on page 13-32).

3-3: If any RPQs require parameters, enter this information into the Parameter List field. (See the documentation that accompanies the RPQ for these parameters.)

3-4: Press PF12 to process the options.

A message will verify the action taken and highlight any errors. If an error is detected, a message appears on the message line at the bottom of your screen. You must correct all errors before continuing or press PF3 to quit.

3-5:

- To Merge RPQ(s) from an RPQ diskette to a Utility disk, go to "Step 4. Select Merge RPQs Option" on page 13-38.
- To exit this procedure, go to "What's Next?" on page 13-39.

Step 4. Select Merge RPQs Option

4-1: Press PF9 to invoke the merge option of the RPQ procedure. See Figure 13-25.

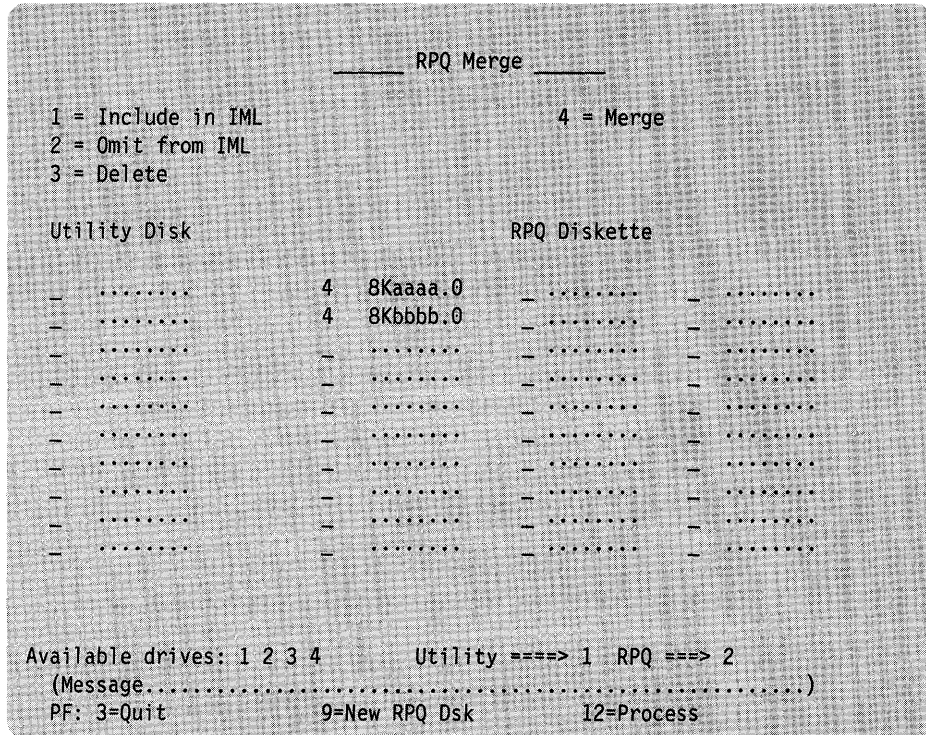

Figure 13-25. RPQ Merge Panel

4-2: After you have inserted the RPQ diskette, press ENTER.

4-3: To select RPQs for merging onto the Utility disk, move the cursor to the RPQ entry you wish to merge. Type a 4 in the options field.

4-4: Press PF12 to process the options.

For a Control Unit with One Disk Drive: If no errors are detected, you will be prompted to insert a Utility diskette. Insert the diskette and press ENTER. The RPQ Utility panel is displayed showing all the merged RPQs on the Utility diskette and indicating that they have been included.

For a Control Unit with More Than One Disk Drive: If no errors are detected, the merged RPQs are displayed under the Utility disk portion of the screen on the RPQ Utility panel.

What's Next?

You can:

- Continue to select RPQ options. See steps 3 and 4.
- Press PF3 to return to the Customize Control Disk Menu and to complete customizing.

Warning: If you have completed customizing the Control disk, the RPQs must be transferred from the Utility disk to the Control disk, or they will not be saved. To transfer these RPQs, see "Step 4. Complete Customizing the Control Disk" on page 13-67 before returning to the Master Menu.

- Press PF3 to return to the Customize Control Disk Menu. Continue to customize the Control disk by selecting another option from the Customize Control Disk Menu.

Use the following table to locate the procedure for the option you want. *Be sure to file your customizing responses (including changes to RPQs) at the end of your customizing, by pressing PF12 on the Customize Control Disk Menu.*

If you want to	Go to page
Configure/Reconfigure	13-9
Define/Redefine the PAM	13-26
Modify Keyboards	13-40
Configure/Reconfigure AEA	13-56

Modify Keyboards Overview

Select this procedure when you want to create unique keyboard layouts to be used on IBM display stations with modifiable keyboards. With this procedure, keyboard layouts can be tailored to meet specific user applications. Figure 13-26 shows the steps used in defining keyboard layouts.

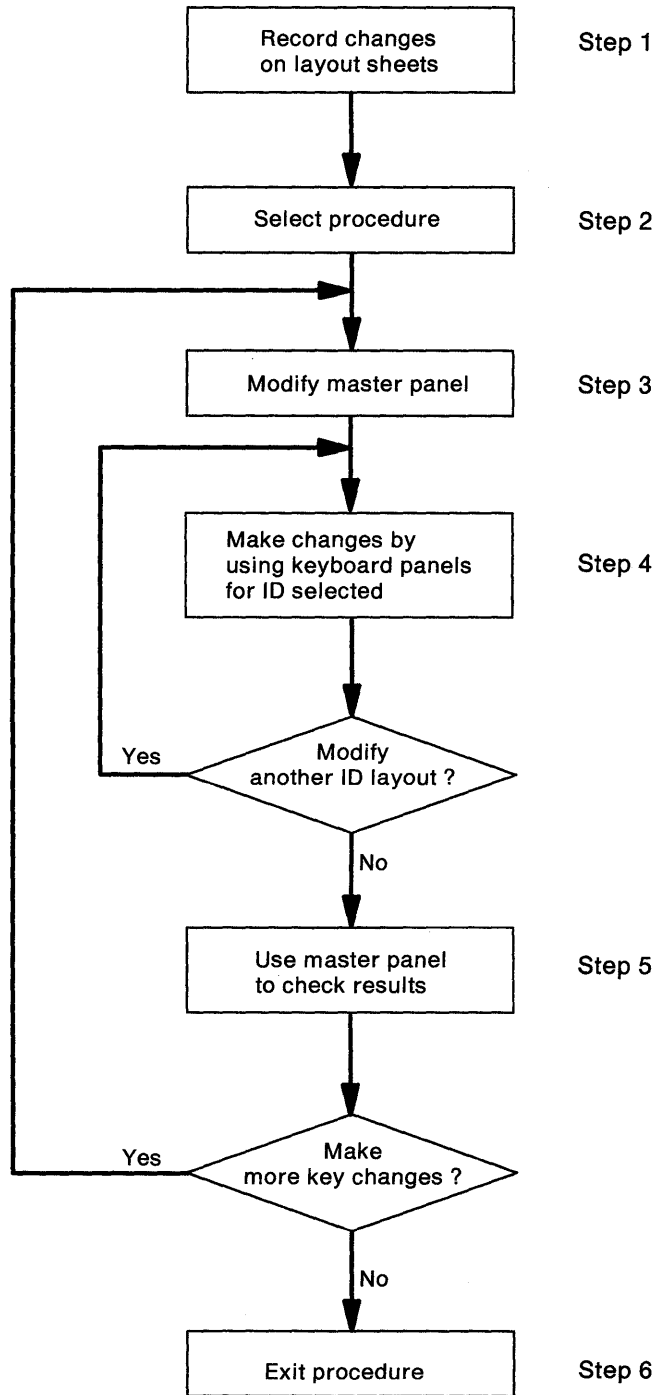

Figure 13-26. Steps for Defining Keyboard Layouts

How to Modify Keyboards

Before you perform this procedure, you must have selected the “Customize the Control Disk” option from the Master Menu and verified the disk drives; if you have not done this, go to “Step 1. Select ‘Customize the Control Disk’ on the Master Menu” on page 13-6.

Getting Ready to Modify Keyboards

Before you start, you will need the following:

- The planning information in Chapter 11
- The completed Keyboard Layout Worksheets from Chapter 20.

PF Keys

You call up a specific function of the customizing program by pressing a PF key. A PF key is operational only if it appears on the panel you are using.



PF: 3=Quit

PF3 PF3 (Quit) quits this procedure and returns you to the Customize Control Disk Menu.

Note: Keyboards with PF13 through 24 are mapped into PF1 through 12. For example, PF13 is PF1 and PF15 is PF3.

Now you are ready to modify keyboards. Turn to page 13-42 and begin the procedure.

How to Modify Keyboards

Step 1. Fill Out Keyboard Layout Worksheets

If they have not already been filled out, record on the Keyboard Layout Worksheets in Chapter 20 the keyboard changes that you are about to make. See "Planning Procedure" on page 11-4 for information on completing the worksheets.

The display station users will need copies of these sheets to determine what keyboard layout they want to use and how to set it up.

Warning: Converged Typewriter keyboards have a PA3 key. You should check with your system programmer to determine if any of your applications already have a function associated with the PA3 key. If the system programmer determines that pressing the (unlabeled) PA3 key will initiate a harmful action, it is advised that you instruct the customizer to use the Modify Keyboard procedure to disable the PA3 key on the keyboard.

Step 2. Select 'Modify Keyboards' on the Customize Control Disk Menu

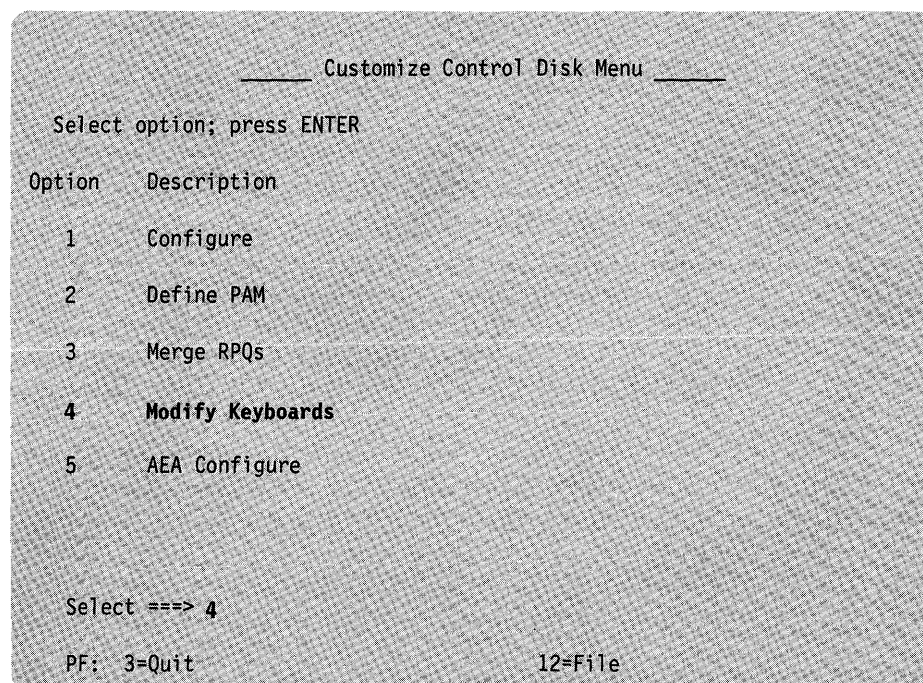

Figure 13-27. Customize Control Disk Menu (select Modify Keyboards)

2-1: Type 4 after Select = = = >

2-2: Press ENTER.

After pressing ENTER, the master panel (Figure 13-28) appears on your screen.

Step 3. Modify the Master Panel

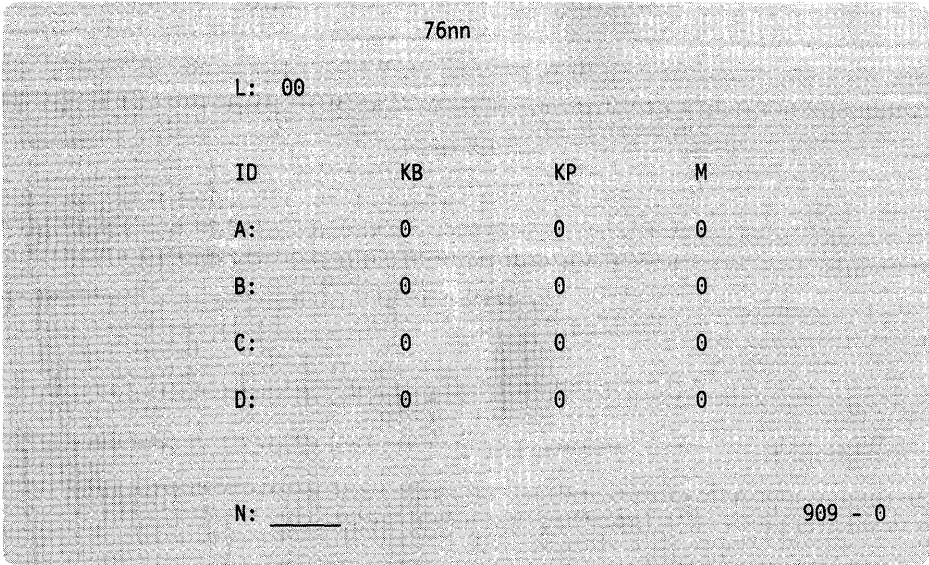

Figure 13-28. Modify Keyboard Master Panel

The cursor is positioned at the language (L) field entry. If there are previously defined keyboard layouts on the disk, there are entries on the master panel that show the ID, the keyboard (KB) type, and the keypad (KP) type for each previously defined layout. There may be an entry in the name (N) field that identifies this set of modified keyboard layouts. An R in the modify (M) field indicates that this keyboard layout has been modified.

- 76nn = Four-digit error code (displayed only if an error is detected). See 3174 Status Codes, GA27-3832, for more information.
- L = Keyboard language number
- ID = Keyboard identification
- KB = 0 - No keyboard type specified
 - = 1 - Converged Typewriter keyboard
 - = 2 - Converged Data Entry keyboard
 - = 3 - Converged APL keyboard
 - = 4 - Enhanced Typewriter keyboard
- KP = 0 - Default National Language keypad
 - = 1 - Data Entry keypad
 - = 2 - Program Function keypad
- N = Name field. Up to 8 alphanumeric characters (first character uppercase alphabetic, no blanks/spaces between characters allowed). See the naming conventions in the Central Site Customizing User's Guide, GA23-0342.
- M = 0 - Not a modified keyboard layout
 - = 1 - Modify standard keyboard layout
 - = 2 - Make more changes to a modified layout
 - = 3 - View keyboard panels
 - = R - Keyboard layout was modified
- 909 = 0 - Original value - Entries not confirmed
 - = 1 - Entries confirmed - Go to keyboard panels
 - = F - Definition process finished - Exit procedure

Use the information on the top of the completed worksheet to fill in this panel.

How to Modify Keyboards

To update the master panel:

3-1: If you want to change the language number, type the new two-digit language number over the current entry. (Table 11-1 on page 11-17 lists the keyboard languages and I/O interface codes that are supported.) All keyboards must use the same language, and this same language number must be specified during customizing (question “121: Keyboard Language and Character Set I/O Interface Code” on page 3-20).

If you assign a new language number, status code 7604 is displayed when the ENTER key is pressed. This is not an error but a warning that, if you confirm this entry by pressing ENTER, all previously modified layouts will be erased and all new keyboard layouts loaded. The master panel will be reset to all zeros except for the L field.

3-2: Type the following in the row for each ID:

- Keyboard type (1, 2, 3, or 4) in the column under KB:

KB = 1 means that the keyboard to be modified for this ID will be a Converged Typewriter keyboard layout.

KB = 2 means that the keyboard to be modified for this ID will be a Converged Data Entry keyboard layout.

KB = 3 means that the keyboard to be modified for this ID will be a Converged Typewriter keyboard layout with the APL mode functions.

Note: You can modify an APL keyboard only if the display station at which you are performing this procedure has APL read-only storage (ROS).

KB = 4 means that the keyboard to be modified for this ID will be an Enhanced Typewriter keyboard layout.

- Keypad type (0, 1, or 2) in the column under KP:

KP = 0 means that the default National Language keypad will be used for this ID.

KP = 1 means that the Data Entry keypad will be used for this ID.

KP = 2 means that the PF keypad will be used for this ID.

- Modify code (0, 1, 2, or 3) in the column under M:

If M equals 0 when the master panel is first displayed, you can:

- Leave the M field 0 if you do not want to define a keyboard for this ID (that is, KB=0 and KP=0 for this ID) or if you do not want to make any key changes but only want to specify a unique keyboard/keypad combination for this ID.
- Change the M field to a 1 if you want to modify the keyboard layout for this ID.

If M equals R when the master panel is first displayed, it means that the keyboard layout for this ID has previously been modified. You can do one of the following with this already-modified keyboard:

- Set M equal to 0 to erase the keyboard modifications for this ID.
- Set M equal to 1 to define a new keyboard layout. Replacing an R with a 1 in the M field erases all previous changes made to this keyboard layout.
- Set M equal to 2 to make changes to a modified keyboard layout.
- Set M equal to 3 to view the modified keyboard layout. The keyboard panels are displayed, but cannot be altered in any way.

3-3: Fill in the KB, KP, and M fields for each ID that you are defining. If all entries are equal to 0 for a particular ID, no keyboard layout will exist for that ID.

3-4: Fill in the optional N (name) field to identify this set of modified keyboards. The name is useful when storing or retrieving sets of modified keyboards from the Central Site Library. See the *Central Site Customizing User's Guide*, GA23-0342, for information on naming conventions and Library member names.

For an explanation of a valid name, see the description of the fields discussed earlier in this step. Following are examples of valid and invalid names.

Example

```
KBDSET1A (valid)
1A KBSET (invalid)
```

3-5: Check the master panel to be sure all entries are correct.

3-6: Move the cursor to the 909 field at the bottom of the master panel, and change the 0 to a 1. Press ENTER.

If you do not want to make any changes at this time (all M fields are equal to 0, 3, or R), then go to "Step 5. Use the Master Panel to Check Your Results" on page 13-54 or to "Step 6. Exit from the Procedure" on page 13-54.

3-7: If an error is detected, all fields that contain errors are highlighted. The cursor is placed at the location of the first error, and a status code is displayed at the top of the screen. See *3174 Status Codes*, GA27-3832, to determine what type of error was made.

Correct the error and press ENTER.

If there is more than one error, after the first error is corrected, the cursor is placed at the location of the next error and its error code is displayed at the top of the screen. Repeat this step until all errors are corrected.

Go to "Step 4. Modify Keyboard Panels" on page 13-46.

Step 4. Modify Keyboard Panels

Warning: When modifying keyboards panels that have characters **unique** to APL2 and CECP, you need to use a device that supports those characters. If you use a device that does not support those characters, they may be misrepresented or displayed as blanks.

When you have finished updating the master panel, keyboard panel 1 is displayed. Because the entire keyboard cannot be shown on a single screen, there are three keyboard panels for each ID. See Figures 13-29 through 13-31.

On the top left of each keyboard panel is the mode selection row. It is divided into three groups: the keyboard group (0, 1, 2), the shift group (3, 4), and the function group (5, 6, 7, 8). Only one selection is allowed in each group for each key change.

Note that you can perform all of the same kinds of changes for each keyboard ID after selecting these operations only once. However, each time a different shift and/or type of change is desired, new selections must be made in the mode selection row.

The information at the bottom left of the screen is the ID, the keyboard (KB) type, and the keypad (KP) type for the keyboard layout that is being defined.

On the bottom right of the keyboard panel is the 910 field. It shows which keyboard panel is displayed. It is used:

- To change from one keyboard panel to another by entering 1, 2, or 3.
For two-language keyboards, enter 0 or 1 in the 910 subfield, to specify the secondary or primary language nomenclature, respectively.
- To cancel the pending key-change operation by entering A.
- To end the modification of the current keyboard ID by entering F.

If an error is detected at any time during a key change, the error number is displayed at the top of the screen. See *3174 Status Codes, GA27-3832*, for keyboard panel error codes. Correct the error and continue.

How to Modify Keyboards

Keyboard Group **Shift Group** **Function Group** (Not displayed)
 012 34 56789

~ \	 1	@ 2	# 3	\$ 4	% 5	^ 6	& 7	* 8	(9) 0	- =	+ =	<- ->
-> ->	Q q	W w	E e	R r	T t	Y y	U u	I i	O o	P p	! ¢	 \	<- ->
Schick Schick Schick	A a	S s	D d	F f	G g	H h	J j	K k	L l	:	"	}	
UpSh UpSh UpSh	> <	Z z	X x	C c	V v	B b	N n	M m	,	.	?	/	DwnSh DwnSh DwnSh
Reset Reset DvCnl		Alt Alt Alt							Space Space Space		Alt Alt Alt		Enter Enter

ID - A KB - 1 KP - 1

910 - 1

Figure 13-29. Converged Typewriter Keyboard Panel 1 — Main Part of Keyboard

012 34 5678

Attn Attn SysRq	Clear Clear	Dup PA1	FldMk PA2 ChgSc	PA3 PA3		/	Space Space	
CrSel CrSel	ErInp	I<- I<-	Ins Ins	Del Del WdDel	1 1	2 2	3 3	->I ->I
ExSel ExSel	ErEOF ErEOF		CrUp CrUp Back		4 4	5 5	6 6	- -
Print Print Ident	Test	<- <- <<-	CrHom	-> -> ->>	7 7	8 8	9 9	Enter Enter
			CrDwn CrDwn Fwd		0 0	.	.	

ID - A KB - 1 KP - 1

910 - 2

Figure 13-30. Converged Typewriter Keyboard Panel 2 — Keys to Right and Left of Main Keyboard

How to Modify Keyboards

0 1 2 3 4 5 6 7 8 9

P13 P13	P14 P14	P15 P15	P16 P16	P17 P17	P18 P18	P19 P19	P20 P20	P21 P21	P22 P22 CrBnk	P23 P23 CrAlt	P24 P24 Click
P1 P1	P2 P2	P3 P3	P4 P4	P5 P5	P6 P6	P7 P7	P8 P8	P9 P9	P10 P10	P11 P11	P12 P12

ID - A KB - 1 KP - 1

910 - 3

Figure 13-31. Converged Typewriter Keyboard Panel 3 — Program Function Keys above Main Keyboard

Keyboard Group (0, 1, 2)

- 0 = The change you want to make is on a Converged Typewriter, Converged Data Entry, or Enhanced Typewriter keyboard.
- 1 = The change that you want to make applies only to the APL key functions on a Converged APL keyboard.
- 2 = The change that you want to make applies to both the typewriter and APL functions of the keys involved on a Converged APL keyboard.

Shift Group (3, 4)

- 3 = Full-key change.
- 4 = Single-shift change.

Function Group (5, 6, 7, 8)

- 5 = Copy from I/O interface code table.
- 6 = Exchange two functions.
- 7 = Copy a function to another key.
- 8 = Delete a key function.

910 Field Entries

- 1 = Display keyboard panel 1.
- 2 = Display keyboard panel 2.
- 3 = Display keyboard panel 3.
- A = Cancel (abort) the current key-change operation.
- F = All changes have been finished for this ID.

910 Subfield Entries (displayed for two-language keyboards)

- 0 = Display keyboard layout with secondary language nomenclature
- 1 = Display keyboard layout with primary language nomenclature.

Note: The three keyboard panels shown use the English nomenclature. If you are using a different language, see Table 11-1 on page 11-17.

Make Mode Selection Row Entries

These selections have already been made on the worksheet; refer to the Keyboard, Shift, and Function Groups section of the Keyboard Changes Chart.

Start each key change by replacing the proper numbers with an X in the mode selection row as follows.

Make only one selection in each group in the mode selection row:

1. The first three numbers (0, 1, 2) are the keyboard group. If the keyboard type specified on the master panel is a Typewriter (KB = 1) or Data Entry (KB = 2), the 0 is highlighted. Do not make an entry in this field; go to step 3 of this section.
2. If the keyboard type specified on the master panel is an APL keyboard (KB = 3), and the display station at which you are running the procedure has an APL ROS, then the entire keyboard group (0, 1, 2) is highlighted:
 - To change only the Typewriter key functions, type X over the 0.
 - To change only the APL mode functions, type X over the 1.
 - To change both Typewriter and APL mode functions, type X over the 2.

If you type X over the 2, the Typewriter keys are displayed when keyboard panel 1 is on the screen. The APL functions for the keys modified are changed along with the Typewriter functions. To display the APL functions to verify that they were changed, type an X over the 1 in the keyboard group and press ENTER.

3. Numbers 3 and 4 are the shift group.
 - To change the entire key (upper-shift, lower-shift, and alternate-shift positions), type X over the 3.
 - To choose a single-shift position change, type X over the 4.
4. Numbers 5, 6, 7, and 8 are the function group. Type an X over the appropriate number to select the type of key change.
 - 5 – Copy from the I/O interface code table.
 - 6 – Exchange two functions.
 - 7 – Copy a function from one key to another key.
 - 8 – Delete a key function.

5. Press ENTER.

6. **If an error is detected**, the cursor is placed at the location of the first group in error. The status code of the first error is displayed at the top of the screen, and all groups with errors are highlighted. See *3174 Status Codes, GA27-3832*, to determine what type of error was made.

Correct the error and press ENTER.

Repeat this step until all errors in the mode selection row are corrected.

7. Proceed with the key change as follows:
 - Copy from the I/O interface code table (see “Perform a Copy from the I/O Interface Code Table” on page 13-50).
 - Exchange two functions (see “Exchange the Function of Two Keys” on page 13-51).
 - Copy a function to another key (see “Copy from One Key to Another” on page 13-52).
 - Delete a function (see “Delete a Key Function” on page 13-53).

Perform a Copy from the I/O Interface Code Table

After the mode selection row is updated, the number 5 in the mode selection row is highlighted and "I/O = 00" is displayed to the right of the mode selection row. The cursor is positioned under the first 0.

1. Type the hexadecimal (hex) code that you are assigning over the 00. The I/O Code is located on the worksheet in the "I/O Code" field. (If the I/O code is not present in this field, the code for the I/O Code Character you are copying can be found in *3174 Character Set Reference*, GA27-3831.)

For example: The hex code for the plus sign (+) is defined as 4E in the English (U.S.) I/O Interface Code Table.

For two-language keyboards, enter the 0 or 1 in the 910 subfield to specify the secondary or primary language layout, respectively. Modifications made to keys during this copy procedure do not affect the keys on the hidden keyboard layout.

2. Press ENTER.

The hex code is translated into its corresponding character, followed by -->. In the example, I/O = 4E becomes I/O = + -->.

3. If the key to be changed is not displayed on the screen, call up the needed keyboard panel by typing its number (1, 2, or 3) after the 910 and pressing ENTER.

Note: Entering A after the 910 cancels the current key change operation.

4. Move the cursor to the key that you are changing (the *To* key on the worksheet).

For a full-key change, place the cursor anywhere within the key.

For a single-shift change, place the cursor in the proper shift row within the key.

5. Press ENTER.

The character representation for the hex I/O code that you selected is placed on the key and highlighted.

6. If you have another change for the current ID in which *all* the mode selection row entries are identical with those highlighted, it is not necessary to make entries in the mode selection row for your next change. Start from step 1.

To make a different type of key change for the current keyboard ID, return to "Step 4. Modify Keyboard Panels" on page 13-46.

Note: You can start another key change from any keyboard panel (1, 2, or 3).

7. If you have finished defining the current keyboard ID, replace the number after the 910 with an F and press ENTER.

If there is another keyboard to be defined, keyboard panel 1 of the next keyboard ID is displayed. Return to "Step 4. Modify Keyboard Panels" on page 13-46.

If all the keyboard IDs specified in the master panel have been defined, the master panel is displayed. Go to "Step 5. Use the Master Panel to Check Your Results" on page 13-54 or go to "Step 6. Exit from the Procedure" on page 13-54.

Exchange the Function of Two Keys

After the mode selection row is updated, the number 6 in the mode selection row is highlighted and the cursor is at the home position in the mode selection row.

1. If neither key (*From* or *To*) that you are going to exchange is displayed on the current keyboard panel, call up the needed panel by typing its number (1, 2, or 3) after the 910 at the bottom of the screen.

For two-language keyboards, enter the 0 or 1 in the 910 subfield to specify the secondary or primary language layout, respectively.

Press ENTER.

2. Move the cursor to the first key to be changed (the *From* key on the worksheet).

For a full-key exchange, place the cursor anywhere within the key.

For a single-shift exchange, place the cursor anywhere in the proper shift row within the key.

3. Press ENTER.

The selected key is highlighted and is displayed to the right of the mode selection row, followed by <--> to signify that an exchange is pending. If full-key mode was selected, all the shift states (upper/lower/alternate) of the selected key are displayed to the right of the mode selection row.

4. If the other key to be exchanged (the *To* key) is not displayed on the screen, call up the needed keyboard panel by typing its number (1, 2, or 3) after the 910 and pressing ENTER.

Note: Entering A after the 910 cancels the current key change operation.

5. Move the cursor to the other key to be exchanged (the *To* key on the worksheet).

For a full-key exchange, place the cursor anywhere on the key.

For a single-shift exchange, place the cursor in the proper shift row on the key.

6. Press ENTER.

The exchange is made. The keys that were exchanged are highlighted if they are on the current keyboard panel. For two-language keyboards, if a modification occurred on both the secondary and primary language layouts, a 2 appears to the right of the mode selection row.

7. If you have another change for the current ID in which *all* the mode selection row entries are identical with those highlighted, it is not necessary to make entries in the mode selection row for your next change. Start from step 1 on page 13-51.

To make a different type of key change for the current keyboard ID, return to "Step 4. Modify Keyboard Panels" on page 13-46.

Note: You can start another key change from any keyboard panel (1, 2, or 3).

8. If you have finished defining the current keyboard ID, replace the number after the 910 with an F and press ENTER.

If there is another keyboard to be defined, keyboard panel 1 of the next keyboard ID is displayed. Return to "Step 4. Modify Keyboard Panels" on page 13-46.

How to Modify Keyboards

If all the keyboard IDs specified in the master panel have been defined, the master panel is displayed. Go to “Step 5. Use the Master Panel to Check Your Results” on page 13-54 or to “Step 6. Exit from the Procedure” on page 13-54.

Copy from One Key to Another

After the mode selection row is updated, the number 7 in the mode selection row is highlighted and the cursor is at the home position in the mode selection row.

1. If the key that you are going to copy (the *From* key) is not displayed on the current keyboard panel, call up the needed panel by typing its number (1, 2, or 3) after the 910.

For two-language keyboards, enter the 0 or 1 in the 910 subfield to specify the secondary or primary language layout.

Press ENTER.

2. Move the cursor to the key to be copied (the *From* key on the worksheet).

For a full-key copy, place the cursor anywhere within the key.

For a single-shift copy, place the cursor in the proper shift row within the key.

3. Press ENTER.

The selected key is highlighted and is displayed to the right of the mode selection row, followed by --> to signify that a copy is pending. If full-key mode was selected, all the shift states (upper/lower/alternate) of the selected key are displayed to the right of the mode selection row.

4. If the key to which you are copying the *From* key (the *To* key) is not displayed on the screen, call up the needed keyboard panel by typing its number (1, 2, or 3) after the 910 and pressing ENTER.

Note: Entering A after the 910 cancels the current key change operation.

5. Move the cursor to the destination key (the *To* key on the worksheet).

For a full-key copy, place the cursor anywhere within the key.

For a single-shift copy, place the cursor in the proper shift row within the key.

6. Press ENTER.

The copy is made, and the changed key is highlighted.

For two-language keyboards, if a modification occurred on both the secondary and primary language layouts, a 2 appears to the right of the mode selection row.

7. If you have another change for the current ID in which *all* the mode selection row entries are identical with those highlighted, it is not necessary to make entries in the mode selection row for your next change. Start from step 1 on page 13-52.

To make a different type of key change for the current keyboard ID, return to “Step 4. Modify Keyboard Panels” on page 13-46.

Note: You can start another key change from any keyboard panel (1, 2, or 3).

8. If you have finished defining the current keyboard ID, replace the number after the 910 with an F and press ENTER.

If there is another keyboard to be defined, keyboard panel 1 of the next keyboard ID is displayed. Return to “Step 4. Modify Keyboard Panels” on page 13-46.

If all the keyboard IDs specified in the master panel have been defined, the master panel is displayed. Go to “Step 5. Use the Master Panel to Check Your Results” on page 13-54 or to “Step 6. Exit from the Procedure” on page 13-54.

Delete a Key Function

After the mode selection row is updated, the number 8 in the mode selection row is highlighted and the cursor is at the home position in the mode selection row.

1. If the key that you are going to delete (the *From* key) is not displayed on the current keyboard panel, call up the needed panel by typing its number (1, 2, or 3) after the 910 at the bottom of the screen.

For two-language keyboards, enter a 0 or 1 in the 910 subfield to specify the secondary or primary language layout, respectively.

Press ENTER.

2. Move the cursor to the key to be deleted (the *From* key on the worksheet).

To delete a full key, place the cursor anywhere within the key.

To delete a single-shift position, place the cursor in the proper shift row within the key.

3. Press ENTER.

The key is deleted, and the line to the right of the key is highlighted.

For two-language keyboards, if a modification occurred on both the secondary and primary language layouts, a 2 appears to the right of the mode selection row.

4. If you have another change for the current ID in which *all* the mode selection row entries are identical with those highlighted, it is not necessary to make entries in the mode selection row for your next change. Start from step 1.

To make a different type of key change for the current keyboard ID, return to “Step 4. Modify Keyboard Panels” on page 13-46.

Note: You can start another key change from any keyboard panel (1, 2, or 3).

5. If you have finished defining the current keyboard ID, replace the number after the 910 with an F and press ENTER.

If there is another keyboard to be defined, keyboard panel 1 of the next keyboard ID is displayed. Return to “Step 4. Modify Keyboard Panels” on page 13-46.

If all the keyboard IDs specified in the master panel have been defined, the master panel is displayed. Go to “Step 5. Use the Master Panel to Check Your Results” on page 13-54 or to “Step 6. Exit from the Procedure” on page 13-54.

Step 5. Use the Master Panel to Check Your Results

When you have completed all the keyboard changes, the master panel is again displayed. The 0's, 1's, and 2's in the modify (M) field have been replaced by Rs for the new keyboards that have been defined.

Note: If you want to make more changes, you can go back to "Step 3. Modify the Master Panel" on page 13-43.

To view one or more of the keyboards again:

5-1: Enter a 3 in the modify fields of the IDs that you want to check. A 3 in the modify field allows you to view the keyboard panels, but you cannot make any additional changes at this time.

5-2: Change the 0 to the right of the 909 to a 1.

5-3: Press ENTER.

Keyboard panel 1 for the first ID with a 3 in the M field is displayed. There are now only two numbers in the mode selection row, 0 and 1. These two numbers are used only if the keyboard type for this ID is APL (KB = 3 on the master panel), and if the display station at which you are performing this procedure has APL read-only storage (ROS). Then you can display the APL key functions by entering an X over the 1. To return to the Typewriter layout, enter an X over the 0.

5-4: Look at the other keyboard panels for this ID by entering the corresponding number (1, 2, or 3) in the 910 field.

For two-language keyboards, enter a 0 or 1 in the 910 subfield to view the secondary or primary language keyboard layout, respectively.

5-5: When you have finished checking the panels for that ID, type an F in the 910 field.

5-6: Press ENTER.

If there is another keyboard ID with a 3 in the M field, keyboard panel 1 for that ID is displayed.

5-7: After all the keyboards requested have been displayed, the master panel is displayed again.

To make more keyboard changes, return to "Step 3. Modify the Master Panel" on page 13-43.

Step 6. Exit from the Procedure

After completing all the keyboard definitions, exit from the keyboard definition procedure by replacing the 0 to the right of the 909 with an F. Press ENTER.

The master panel is removed from the screen, and the definition procedure is completed.

What's Next?

The Customize Control Disk Menu is on your screen.

You can:

- Complete customizing the Control disk.
Warning: If you have completed customizing the Control disk, the responses you made must be transferred to the Control disk, or they will not be saved. To transfer these responses, see "Step 4. Complete Customizing the Control Disk" on page 13-67 before returning to the Master Menu.
- Continue to customize the Control disk by selecting another option from the Customize Control Disk Menu.

Use the following table to locate the procedure for the option you want.

If you want to	Go to page
Configure/Reconfigure	13-9
Define/Redefine the PAM	13-26
Merge RPQs	13-31
Configure/Reconfigure AEA	13-56

How to Configure the AEA

Select this procedure if you want to type in the responses to the numbered questions on the AEA Configure Worksheets. This procedure must be selected whenever you initially customize a Control disk for the Asynchronous Emulation Adapter (AEA). It can also be used if you want to change any information entered previously while customizing the Control disk by typing over or deleting any previous responses.

Before you perform this procedure, you must have selected the "Customize the Control Disk" option from the Master Menu and verified the disk drives; if you have not done this, see "Step 1. Select 'Customize the Control Disk' on the Master Menu" on page 13-6.

Getting Ready to Configure for the AEA

Before you start, you will need the following:

- The AEA Configure Worksheets with the responses written on them (Worksheets 16 through 22)
- You may need to see *3174 Status Codes*, GA27-3832.

PF Keys

You call up a specific function of the customizing program by pressing a PF key. As you follow the AEA Configure procedure, your choice of PF keys varies from panel to panel.

Some or all of these PF keys may appear on panels during the AEA Configure procedure:

PF:3=Quit 4=Default 7=Back 8=Fwd 10=Page Back 11=Page Fwd 12=Done

- PF3** PF3 (Quit) is used to quit the procedure and erases your responses made during the present session from all the panels. This key must be pressed twice to exit the AEA procedure. After pressing this key once, you will receive a message asking you if you are sure that you wish to quit this procedure. Press this key a second time to return to the Customize Control Disk Menu.
- PF4** PF4 (Default) erases your responses from the current panel. The screen clears, and the same panel, filled with default responses, reappears.

- PF7** PF7 (Back) brings up the previous panel. When you press PF7, the responses you have entered on the current panel are saved temporarily, even if the panel is not completed. When you return to the partially completed panel, you can complete it.
- PF8** PF8 (Forward) checks the responses on the current panel for errors. If there are none, the next panel appears on the screen. If there are any errors, an error message appears on the message line. You cannot advance to the next panel until all errors are corrected. When you press PF8, the responses you have entered on the current panel are saved temporarily, even if the panel is not completed.
- PF10** PF10 (Page Back) is used only on the AEA Station Set panel in this procedure. This key checks the entire panel, which is made up of a series of screens, for errors, and pages back to the previous screen while displaying any errors that are encountered.
- PF11** PF11 (Page Forward) is used only on the AEA Station Set panel in this procedure. This key checks the entire panel, which is made up of a series of screens, for errors, and pages forward to the next screen while displaying any errors that are encountered.
- PF12** Pressed at the end of the AEA Configure procedure, PF12 (Done) saves all the responses you have entered on all the previous panels onto the Utility disk. The Customize Control Disk Menu appears on your screen.

If you are using a Data Entry, Data Entry Keypunch, or non-QWERTY keyboard without PF12, use the PA2 key.

Note: Keyboards with PF13 through 24 are mapped into PF1 through 12. For example, PF13 is PF1 and PF15 is PF3.

Now you are ready to configure for the AEA. Turn to page 13-58 and begin the procedure.

Step 1. Select 'AEA Configure' on the Customize Control Disk Menu

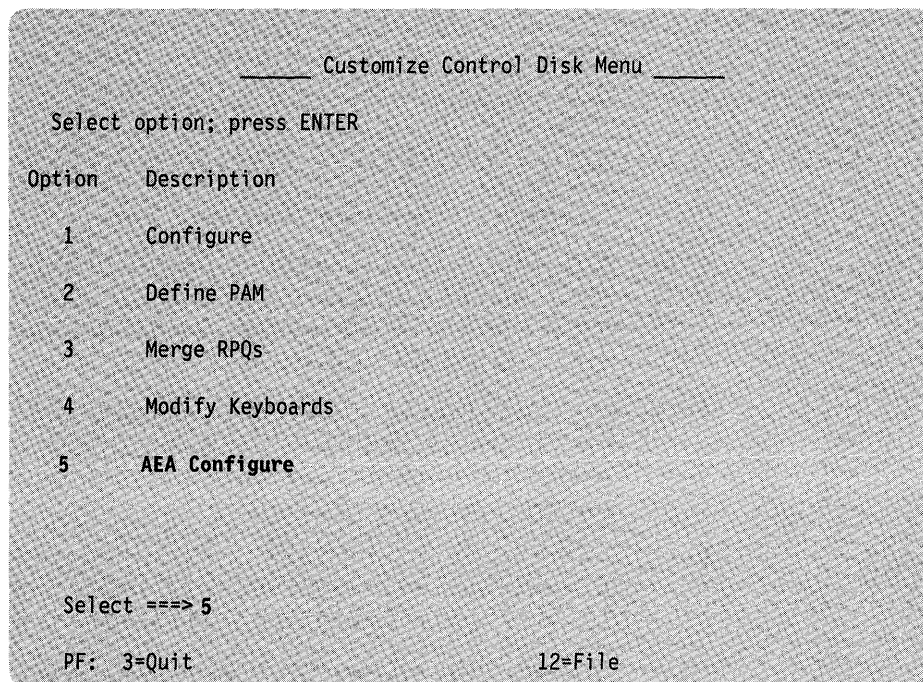

Figure 13-32. Customize Control Disk Menu (select AEA Configure)

1-1: Type **5** after Select = = = >

1-2: Press the ENTER key on the keyboard.

After pressing ENTER, the AEA Configure panel (Figure 13-33) appears on your screen.

Step 2. Enter Responses on the AEA Configure Panel

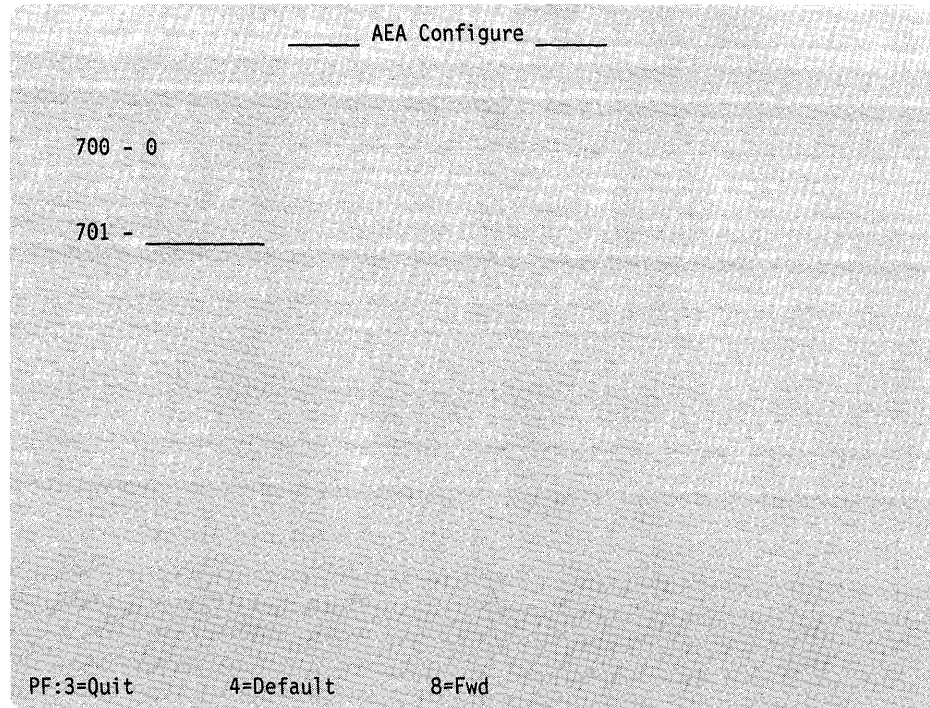

Figure 13-33. AEA Configure Panel

2-1: Locate the filled-in "Worksheet 18—AEA Configure."

2-2: Type each response written on the worksheet in the field following the question number.

2-3: Press the ENTER key.

If you have any invalid responses, you can correct them as described in "Correcting Invalid Responses" on page 13-4.

2-4: If you want a record of the responses you typed in, print a local copy of the panel. (If necessary, see "Printing a Local Copy" on page 13-3.)

2-5: Press PF8 to advance to the next panel.

If you have any invalid responses, you can correct them as described in "Correcting Invalid Responses" on page 13-4. When all the responses are valid, press PF8 to advance to the next panel.

Step 3. Enter Responses on the AEA Port Set Panel

The AEA Port Set panel (Figure 13-34) appears next.

	Name	Session Limit	Port Type	Modem Type
1	_____	_____	_____	_____
2	_____	_____	_____	_____
3	_____	_____	_____	_____
4	_____	_____	_____	_____
5	_____	_____	_____	_____
6	_____	_____	_____	_____
7	_____	_____	_____	_____
8	_____	_____	_____	_____
9	_____	_____	_____	_____
10	_____	_____	_____	_____
11	_____	_____	_____	_____
12	_____	_____	_____	_____
13	_____	_____	_____	_____
14	_____	_____	_____	_____
15	_____	_____	_____	_____
16	_____	_____	_____	_____

PF:3=Quit 4=Default 7=Back 8=Fwd

Figure 13-34. AEA Port Set Panel

3-1: Locate the filled-in “Worksheet 19—AEA Port Set.”

3-2: Type in the responses recorded on the worksheet.

Note: If you clear out the name field on a Port Set entry, the rest of the responses are erased when you press ENTER or PF8.

3-3: Press the ENTER key.

If you have any invalid responses, you can correct them as described in “Correcting Invalid Responses” on page 13-4.

3-4: If you want a record of the responses you typed in, print a local copy of the panel. (If necessary, see “Printing a Local Copy” on page 13-3.)

3-5: Press PF8 to advance to the next panel.

If you have any invalid responses, you can correct them as described in “Correcting Invalid Responses” on page 13-4. When there are no invalid responses, press PF8 to advance to the next panel.

Step 4. Enter Responses on the AEA Port to Port Set Map Panel

The AEA Port to Port Set Map panel (Figure 13-35) appears next.

AEA Port to Port Set Map

TA (HG = 26)	0	1	2	3	4	5	6	7
(0 - 7)	—	—	—	—	—	—	—	—
(8 - 15)	—	—	—	—	—	—	—	—
(16-23)	—	—	—	—	—	—	—	—
(24-31)	—	—	—	—	—	—	—	—
	0	1	2	3	4	5	6	7
AEA 1 (HG = 21):	—	—	—	—	—	—	—	—
AEA 2 (HG = 22):	—	—	—	—	—	—	—	—
AEA 3 (HG = 23):	—	—	—	—	—	—	—	—
1 =	2 =	3 =	4 =					
5 =	6 =	7 =	8 =					
9 =	10 =	11 =	12 =					
13 =	14 =	15 =	16 =					

PF: 3=Quit 4=Default 7=Back 8=Fwd

Figure 13-35. AEA Port to Port Set Map Panel

4-1: Locate the filled-in “Worksheet 20—AEA Port to Port Set Map.”

4-2: Type in the responses recorded on the worksheet.

4-3: Press the ENTER key.

If you have any invalid responses, you can correct them as described in “Correcting Invalid Responses” on page 13-4.

4-4: If you want a record of the responses you typed in, print a local copy of the panel. (If necessary, see “Printing a Local Copy” on page 13-3.)

4-5: Press PF8 to advance to the next panel.

If you have any invalid responses, you can correct them as described in “Correcting Invalid Responses” on page 13-4. When there are no invalid responses, press PF8 to advance to the next panel.

Step 5. Enter Responses on the AEA Station Set Panels

The AEA Station Set Panels (Figure 13-36) appear next.

The screenshot shows two identical panels titled "AEA Station Set". Each panel contains a grid of question numbers and responses. The questions are numbered from 721 to 783. The responses are entered in the following format: question number - response. For example, "721 -" followed by a horizontal line, "725 - 1", "731 - 1", "732 - 1", "733 - 0", "734 -", "735 - 0", "736 - 1", "737 -", "741 - 000", "742 - 015", "743 - 1", "751 -", "752 -", "761 - 1", "762 - 1", "763 - 1", "764 - 1", "771 - 1", "772 - 1", "773 - 1", "774 - 1", "775 - 1", "781 - 0", "782 - 0", "783 - 066". At the bottom of each panel, there are navigation instructions: "PF:3=Quit", "7=Back", "8=Fwd", "10=PgBack", and "11=PgFwd".

Figure 13-36. AEA Station Set Panel

5-1: Locate the filled-in AEA Station Set Worksheets (worksheets numbered 21).

5-2: Type in the responses recorded on the first AEA Station Set Worksheet; the worksheets are numbered to the left of question 721.

5-3: Press ENTER.

If you have any invalid responses, you can correct them as described in "Correcting Invalid Responses" on page 13-4.

5-4: If you want a record of the responses you typed in, print a local copy of the panel. (If necessary, see "Printing a Local Copy" on page 13-3.)

5-5: To advance to the next AEA Station Set panel, press PF11.

When you press PF11, the customizing program checks the responses on the displayed screen and compares responses between AEA Station Set panels. You can correct any invalid responses on the displayed AEA Station Set panel, as described in "Correcting Invalid Responses" on page 13-4. If responses between the AEA Station Sets are incompatible, an error message indicating the error is displayed in the message area. The AEA Station Set numbers in conflict are displayed in the error message. The question numbers with contradictory responses are highlighted on each AEA Station Set panel in error. Correct the first error as described in "Correcting Invalid Responses" on page 13-4 and proceed to correct each additional error until no errors are displayed. When there are no invalid responses, press PF11 to advance to the next AEA Station Set panel.

Note: If you wish to change the responses on a previous AEA Station Set panel, press PF10 to page back to the panel. Press PF11 to check the new responses and advance to the next AEA Station Set panel.

If you plan to change all the responses on an AEA Station Set, clear the Station Set name question (721) and press ENTER. Clearing the name field clears all other entries on the AEA Station Set.

5-6: Repeat steps 5-1 through 5-4 for each AEA Station Set Worksheet, but **be sure to enter the AEA Station Sets in numeric order** (for example, AEA Station Set 1, AEA Station Set 2, and so on).

5-7: When you have completed typing in all the responses on all the AEA Station Set worksheets, press PF8 to advance to the next AEA Configuration panel. If you have any invalid responses, you can correct them as described in "Correcting Invalid Responses" on page 13-4. You may wish to perform a local copy of the corrected panel as described in "Printing a Local Copy" on page 13-3. When there are no invalid responses, press PF8 to advance to the next AEA Configuration panel.

Step 6. Enter Responses on the AEA Default Destination Panel

The AEA Default Destination panel (Figure 13-37) appears next.

The size of the screen you are using to customize will determine how much of the panel you see. For example, a 3278 Model 2 will show only 24 lines as shown in Figure 13-12, while a 3278 Model 4 will display 43 lines (the entire panel).

The Station Set Name and Session Limit fields are filled in by the customizing program according to previous responses.

AEA Default Destination						
Station Set	Station Set Name	Session Limit	Session			LT5
			LT1	LT2	LT3	
1						
2						
3						
4						
5						
6						
7						
8						
9						
10						
11						
12						
13						
14						
15						
16						
17						
18						
19						

Figure 13-37. AEA Default Destination Panel (24 lines displayed)

6-1: Locate the filled-in “Worksheet 22—AEA Default Destination.”

6-2: Type in the LT responses recorded on the AEA Default Destination Worksheet. *The AEA Station Set Names and Session Limit columns have been copied to this panel by the customizing program from previous panel input.*

6-3: Press ENTER.

If you have any invalid responses, you can correct them as described in “Correcting Invalid Responses” on page 13-4.

6-4: If you want a record of the responses you typed in, print a local copy of the panel. (If necessary, see "Printing a Local Copy" on page 13-3.)

6-5: To advance to the last AEA Default Destination panel, press PF11. If you have any invalid responses, you can correct them as described in "Correcting Invalid Responses" on page 13-4. **If you wish to change the responses on the previous AEA Default Destination panel, press PF10 to page back to the panel.** Press PF11 to check the new responses and advance to the next AEA Default Destination panel.

6-6: When you have completed typing in all the responses on the AEA Default Destination panels, press PF8 to advance to the last AEA Configuration panel. If you have any invalid responses, you can correct them as described in "Correcting Invalid Responses" on page 13-4. When there are no invalid responses, press PF8 to advance to the last AEA Configuration panel.

Step 7. Press PF12 to Save the Panels

When all the panels that you need have appeared, the screen clears. A new panel, AEA Configure Complete (Figure 13-38), appears.

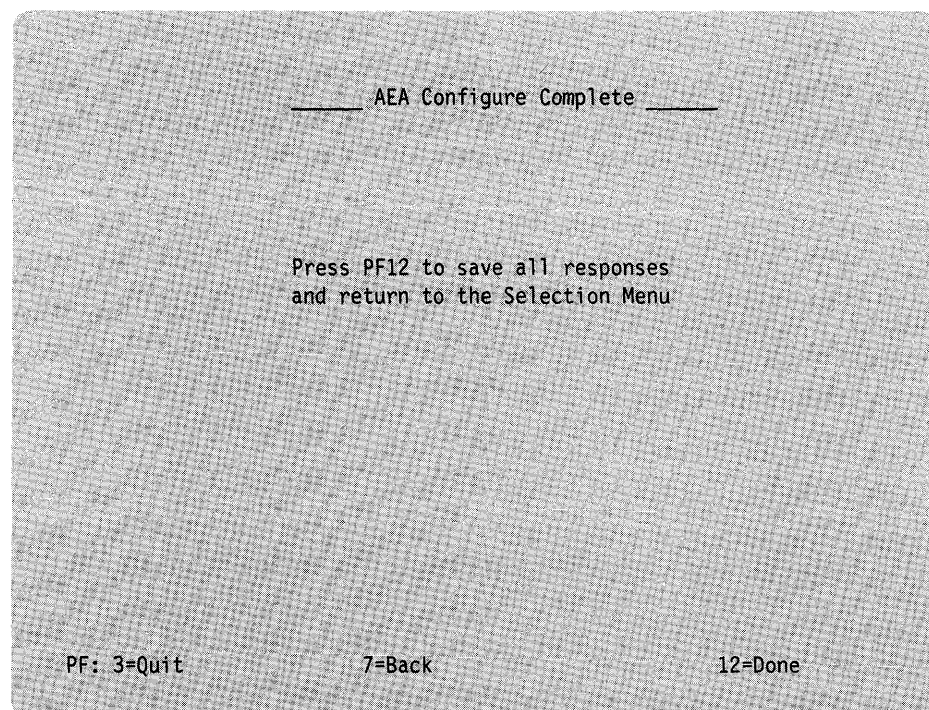

Figure 13-38. AEA Configure Complete Panel

Warning: If you press PF3, the responses you have entered on **all** previous panels within this procedure will be erased.

7-1: Press PF12 to permanently save all the panels completed during the AEA Configure procedure. This information will be stored on the Utility disk.

What's Next?

The Customize Control Disk Menu is on your screen.

You can:

- Complete customizing the Control disk.

Warning: If you have completed customizing the Control disk, the responses you made must be transferred from the Utility disk to the Control disk, or they will not be saved. To transfer these responses, see "Step 4. Complete Customizing the Control Disk" on page 13-67 before returning to the Master Menu.

- Continue to customize the Control disk by selecting another option from the Customize Control Disk Menu.

Use the following table to locate the procedure for the option you want.

If you want to	Go to page
Configure/Reconfigure	13-9
Define/Redefine the PAM	13-26
Merge RPQs	13-31
Modify Keyboards	13-40

Step 4. Complete Customizing the Control Disk

The Customize Control Disk Menu is displayed on the screen.

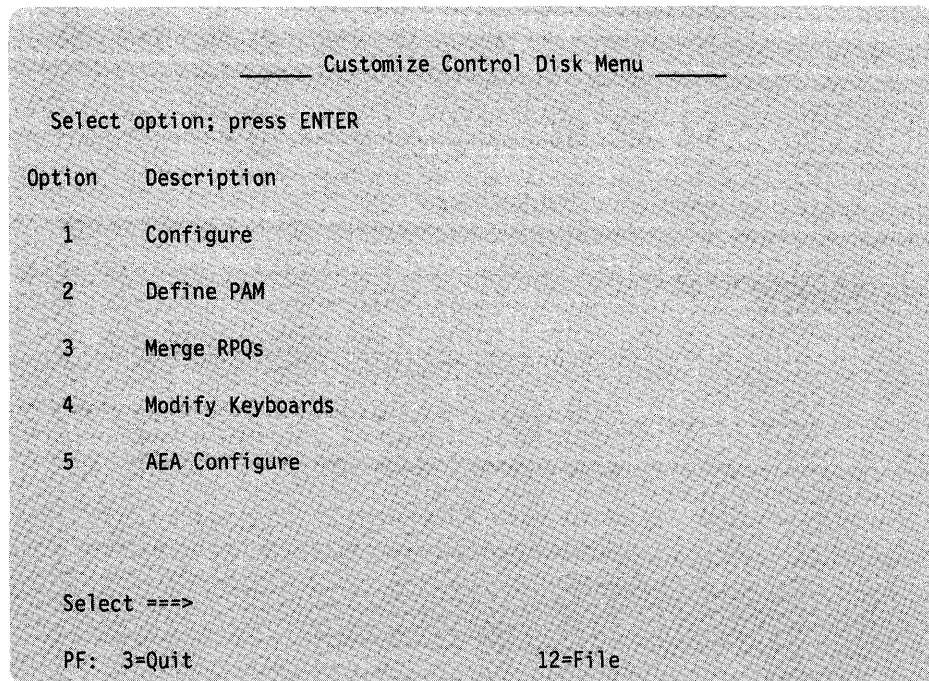

What happens next depends on the number of available drives on the 3174.

For a Control Unit with One Disk Drive

4-1: Press PF12.

The Customize Control Disk Completion panel displays a processing message near the bottom of the screen. See Figure 13-39.

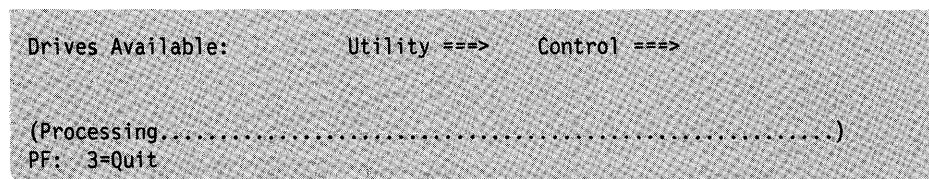

Figure 13-39. Customize Control Disk Completion Panel

4-2: After processing completes, remove the diskette and insert the **original** Control diskette, close the drive, and press ENTER. A processing message is redisplayed. After processing completes, remove the Control diskette and insert the **original** Utility diskette.

4-3: Press ENTER.

4-4: The Master Menu is displayed. Go to "What's Next?" on page 13-68.

For a Control Unit with More Than One Disk Drive

4-1: Press PF12.

The Customize Control Disk Completion panel displays a processing message near the bottom of the screen. See Figure 13-39 on page 13-67. When processing is completed, your responses during the customizing procedures are transferred from the Utility disk to the Control disk.

4-2: After processing is completed, the Master Menu is displayed on the screen.

4-3: Go to "What's Next?"

What's Next?

- With the Master Menu displayed on your screen, you can:
 - Select a different customizing procedure. See the "3174 Quick-Reference Guide for Customizing" to locate the information for the procedure you have chosen or to determine the next procedure to perform.
 - If you have completed customizing the Control disk and are using a diskette, you can remove it and insert another diskette to begin customizing it.
 - You can stop customizing.
- A Control disk is now customized for the host and device attachments you specified and can be used to bring a control unit online.

On 3174 Models 1R, 2R, 3R, 51R, 52R, 53R, 81R, and 82R, remove any Control diskettes you may have customized. To put the control unit online, IML with the Control disk that you use for normal operations (which may be the one that you just customized), and notify the host/Help desk that customizing is completed.

On 3174 Model 1L, remove any Control diskettes you may have customized. To put the control unit online, IML with the Control disk that you use for normal operations (which may be the one you just customized), turn the Channel Interface switch to the Online position, and notify the host/Help desk that customizing is completed.

Chapter 14. How to Merge DSL Code

Getting Ready to Merge DSL Code	14-3
Merge DSL Code Overview	14-3
When Must You Merge the DSL Code?	14-3
Merge Procedure	14-5
PF Keys	14-5
Step 1. Select 'Merge DSL' on the Master Menu	14-5
Step 2. Verify Drives	14-6
Step 3. Select the Merge/Delete Option	14-8
Step 4. Making Multiple Merges from the <i>To</i> Disk	14-9
What's Next?	14-10

Getting Ready to Merge DSL Code

Before you start, you will need the following:

- The identity of the customizing keyboard. See Chapter 19.
- *From* disk: A Downstream Load (DSL) disk. This is the disk you are merging from. If you are using a diskette, it should be unprotected.
- *To* disk: A Downstream Load (DSL) disk. This is the disk you are merging to. If you are using a diskette, it should be unprotected.

If more than one type of DSL device or an Asynchronous Emulation Adapter (AEA) is to be used with the control unit, the different DSL disks must be merged. The microcode of one DSL disk is merged onto another DSL disk.

Note: A DSL merge requires a 3174 with two disk drives.

Merge DSL Code Overview

Any 3174 Control Unit that has in its cluster at least one type of downstream load (DSL) display station or an AEA installed must have two drives. (A DSL display station is one that requires the control unit to downstream-load its microcode when it is turned on — for example, a 3290 Information Panel.) The second drive will contain the DSL disk with the DSL code required for operation of DSL display stations or the Asynchronous Emulation Adapter (AEA). This DSL code is downstream-loaded to a DSL display station when it is turned on.

A DSL disk contains the code for one DSL display station or the AEA: the diagnostics, system bringup code, and microcode that a DSL display station requires, or the microcode necessary to support the AEA. If you have more than one type of DSL display station, or an AEA and a DSL display station, you can merge the code from one DSL disk onto another DSL disk. The procedure for merging DSL code is described in this chapter.

When Must You Merge the DSL Code?

The requirement for merging DSL disks depends on how many types of DSL display stations are in the cluster and whether an AEA is installed.

You need to merge DSL code if:

- There is more than one type of DSL display station in the cluster.
- There is an AEA attached plus one or more DSL display stations. You merge the code from one DSL disk onto the other DSL disk. To avoid degrading performance when several different DSL display stations connected to the same 3174 control unit are turned on, always merge the DSL code from the *old* disk to a *new* DSL disk. Repeat the merge procedure until the merged DSL disk contains the code for all the types of DSL display stations in the cluster and code to support any AEAs. If you merged the DSL code to a diskette, you insert it into a diskette drive at IML. The appropriate code is downstream-loaded to each DSL display station when it is turned on.

You do not need to merge DSL code if:

- Only one type of DSL display station is in the cluster. You can copy a DSL diskette to the fixed disk or insert the DSL diskette into a diskette drive at IML. The code is downstream-loaded to each DSL display station when it is turned on.
- There is an Asynchronous Emulation Adapter (AEA) attached and there are no DSL display stations in the cluster. You can copy the DSL diskette to the fixed disk or insert the DSL diskette into a diskette drive at IML. The code is downstream-loaded to support the AEA when the control unit IMLs.

After you select "Merge DSL" on the Master Menu, the DSL Merge panel (Figure 14-1) appears on your screen.

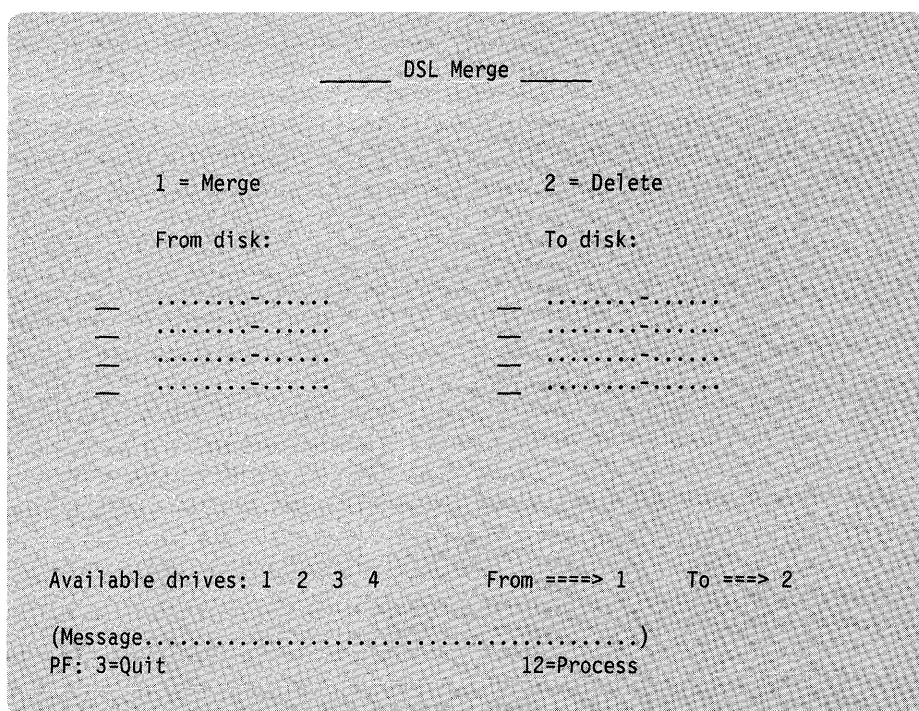

Figure 14-1. DSL Merge Panel

You can merge or delete DSL microcode by selecting these options on this panel. The *From* drive contains the *From* disk that you are merging or copying microcode from, and the *To* drive contains the *To* disk you are merging or copying microcode to.

The available drive fields identify the drives available and the default drive selections for the *From* and *To* disks. The diskette drives are numbered 1 and 2 on the control unit and the fixed disk drives are numbered 3 and 4.

Now you are ready to merge DSL code. Turn to page 14-5 to begin the procedure.

Merge Procedure

The following sequence of steps should be used to merge DSL code from one DSL disk to another DSL disk.

PF Keys

You call up a specific function of the customizing program by pressing a PF key. A PF key is operational only if it appears on the panel you are using.



PF: 3=Quit

12=Process

PF3 PF3 (Quit) quits the procedure without saving any responses since the last ENTER key was pressed. Then the Master Menu appears on your screen.

PF12 PF12 (Process) processes the options specified during this procedure. If you are using a Data Entry, Data Entry Keypunch, or non-QWERTY keyboard without PF12, use PA2.

Note: Keyboards with PF13 through 24 are mapped into PF1 through 12. For example, PF13 is PF1 and PF15 is PF3.

Step 1. Select 'Merge DSL' on the Master Menu

1-1: Display the Master Menu. (See Chapter 12, "How to Display the Master Menu," for directions.)

1-2: Type **2** after Select == =>



Select == => 2

1-3: Press ENTER on the keyboard.

Step 2. Verify Drives

The DSL Merge panel appears on your screen (see Figure 14-2).

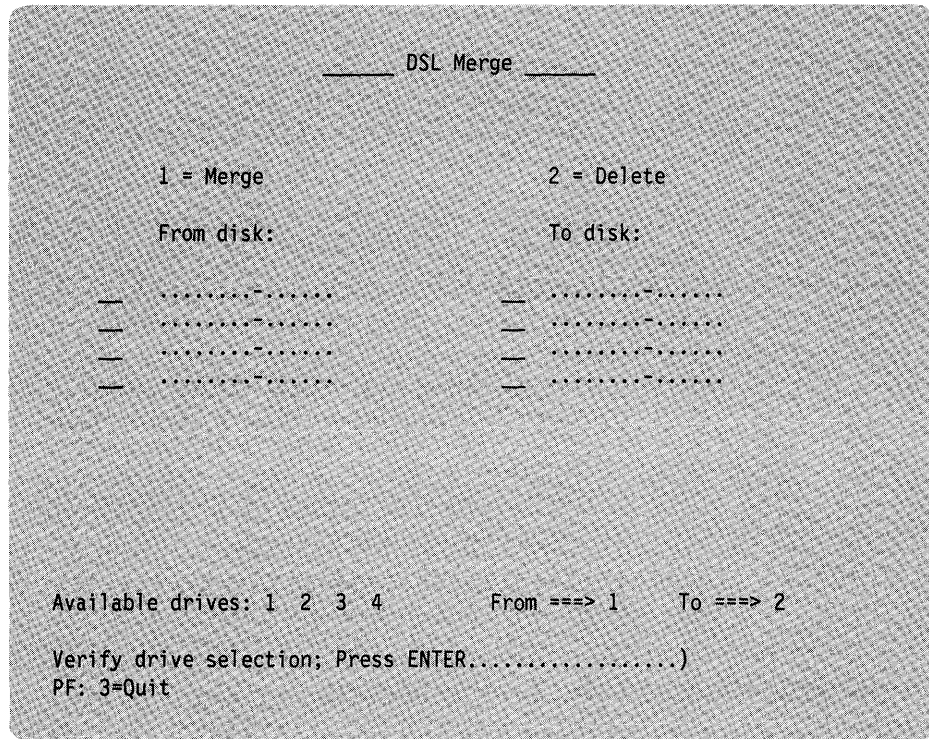

Figure 14-2. DSL Merge Panel for Selecting Drives

2-1: The *From* and the *To* drive fields contain default drive selections. A message will ask you to verify these selections.

If you want to change the default drive selections, after *From* ==> , type the number for the *From* drive. After *To* ==> , type the number for the *To* drive.

2-2: Press ENTER.

If you are using a **fixed disk drive**, a processing message will appear on the message line.

If you are using a **diskette drive**, a message to insert the diskette appears on the message line near the bottom of your screen.

2-3: If you get the message to insert a diskette, insert either the DSL *From* or *To* diskette or both, close the drive(s), and press ENTER. A processing message will appear on the message line.

This procedure checks to make sure the DSL disks are valid. If so, the DSL file names on the disks will appear on the panel under their respective drive headings. See Figure 14-3.

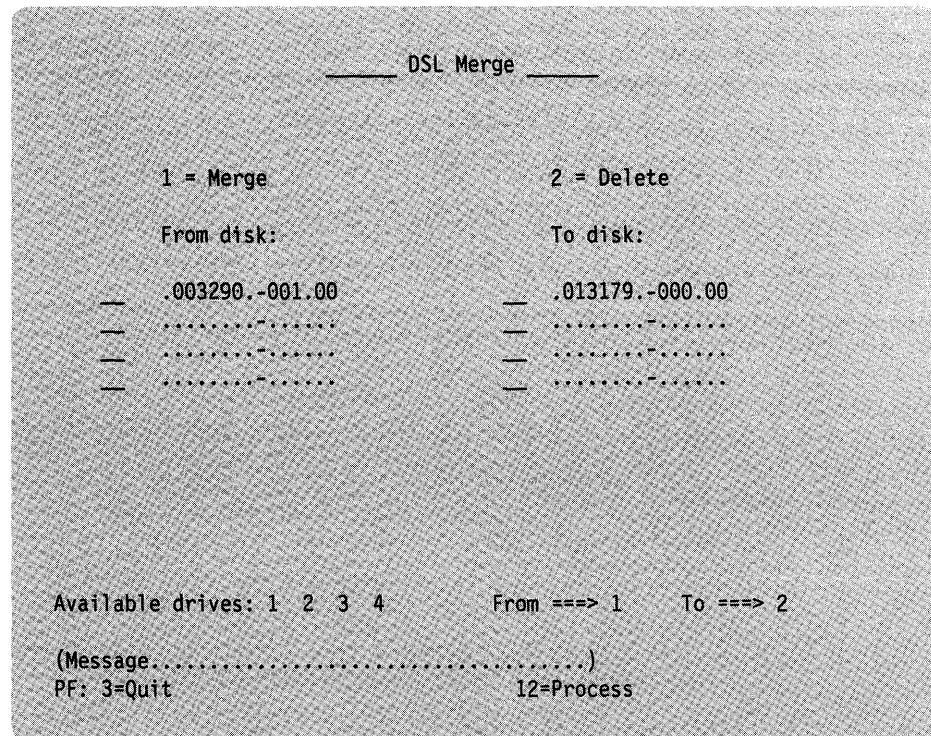

Figure 14-3. The DSL Merge Panel with File Names of Both DSL Disks. Under the *From* and *To* drives appear the name, configuration level, and the microcode level of the product code on the respective DSL device disks. It is possible to have DSL code for as many as four different types of devices or for three different types of devices and any AEAs being used on each DSL disk.

Step 3. Select the Merge/Delete Option

3-1: To merge a file from the *From* disk, type a 1 next to the file name. Press PF12 to process the option. See Figure 14-4.

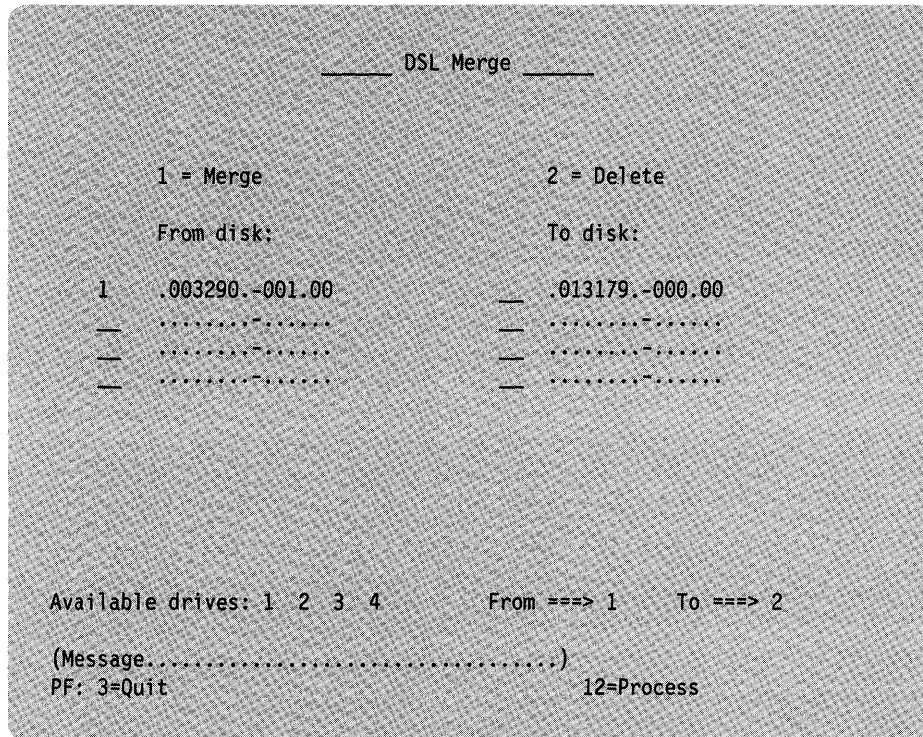

Figure 14-4. Selecting an Option on the DSL Merge Panel

The DSL file of the *From* disk is merged or copied to the *To* disk. When the merge is completed, the panel will show an asterisk in the field where you typed in the option number.

3-2: The DSL Merge procedure lets you delete product code from a DSL *To* disk. For example, you will have to delete a file when you want to merge the microcode of a *From* DSL disk onto a *To* DSL disk that already has the same device but with a different microcode level of product code. You must delete the product code on the *To* disk before or at the same time that you perform the merge function.

To delete a file from the *To* disk:

1. Type a 2 next to the file name you want to delete.
2. Type a 1 next to the file name(s) you want to merge, and press PF12. See Figure 14-5 on page 14-9.

```

          _____ DSL Merge _____

1 = Merge                2 = Delete
From disk:              To disk:
1  .00NNNN.-001.50      2  .00NNNN.-001.00
—  .....-.....
—  .....-.....
—  .....-.....

Available drives: 1 2 3 4      From ==> 1
(Message.....)
PF: 3=Quit                     12=Process

```

Figure 14-5. The DSL Merge Panel with the Delete Option. The *From* and *To* disks have the same device code with different microcode levels. You must delete the microcode release level on the *To* disk before or during the merge procedure.

When the merge is completed, the panel will show that the DSL code that previously appeared in the *To* heading has been deleted. The DSL code that previously appeared under the *To* heading will now appear under the *From* heading.

Step 4. Making Multiple Merges from the *To* Disk

4-1: After the merge is completed, a message appears that prompts you to perform more DSL merge functions.

For each merge or delete you want to make:

1. Insert DSL *From* and/or *To* diskettes, if needed, and press ENTER.
2. Type in the option(s) next to the DSL file names, and press PF12.

4-2: When you do not want to perform any additional merge options:

1. Remove any DSL diskettes.
2. Insert the Utility diskette in the IML drive (if using a diskette drive).
3. Press PF3. The Master Menu appears on your screen.
4. Go to "What's Next?"

What's Next?

The Master Menu with Select = = = > is on your screen.

You can:

- Select a different customizing procedure. See the "3174 Quick-Reference Guide for Customizing" to locate the information for the procedure you have chosen or to determine the next procedure to perform.
- Exit customizing. Remove any diskettes used for the Merge DSL from the drives.
- Identify any diskettes by writing a unique designation on the label; for example, you could identify the diskette's configuration and the 3174 Subsystem Control Unit in which it is to be used.
- To put the 3174 online, ensure that a disk drive contains a customized 3174 Control disk and perform an IML. See the *3174 User's Guide* for directions.

Chapter 15. How to Copy Files

An Overview of the Copy Files Procedure	15-3
Drive Choices	15-4
How to Determine Maintenance and Microcode Levels	15-6
Full Copy	15-7
Modify and Copy	15-8
Copy Customizing Data	15-9
Copy PAM	15-9
Copy Patches	15-10
Copy Modified Keyboards	15-10
Copy RPQs	15-10
Copy Procedure	15-11
PF Keys	15-11
Step 1. Select 'Copy Files' on the Master Menu	15-11
Step 2. Select the Copy Procedure from the Copy Menu	15-12
Step 3. Verify Drives	15-12
Step 4. Define the Modified Responses (for Modify and Copy Only)	15-15
Step 5. Make Multiple Copies of the From Disk	15-16
What's Next?	15-16

An Overview of the Copy Files Procedure

After you select Copy on the Master Menu, the Copy Menu appears on your screen. From the Copy Menu panel, you select the Copy procedure you want (Figure 15-1). You can choose whether you want to duplicate a disk, modify certain configuration data while copying a Control disk, or copy specific portions of a disk.

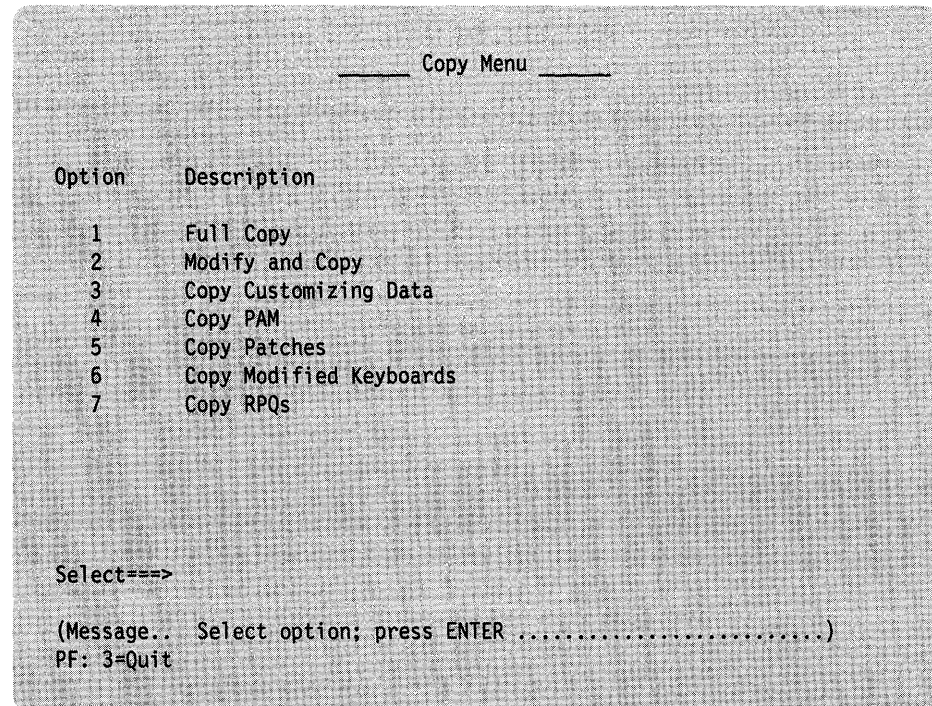

Figure 15-1. Copy Menu. You select a copy option on this screen.

After you have selected an option and pressed ENTER, the prompt in Figure 15-2 on page 15-4 appears. This prompt is used to verify the *From* and *To* drives.

Drive Choices

During the copy procedure you are prompted to select the *From* and *To* drives you are going to use. See Figure 15-2.

```
Available drives: 1 2 3 4      From ==> 1      To ==> 2
```

Figure 15-2. Available Drives Prompt

Figure 15-2 shows a four-drive (two diskette drives and two fixed disk drives) 3174 Control Unit. Drive 1 is the *From* Drive, and drive 2 is the *To* drive. The *From* drive contains the disk that you are copying from (*From* disk), and the *To* drive contains the disk that you are copying to (*To* disk). Disk drives 1 and 2 are diskette drives and disk drives 3 and 4 are fixed disk drives. The Full Copy and Modify and Copy procedures require two disk drives.

The Copy Utility works basically the same for a fixed disk drive as it does for a diskette drive. However, if your 3174 Subsystem Control Unit has one or more fixed disk drives, consider the following when specifying them as the *From* and/or *To* drives.

A Fixed Disk Drive as the To Drive

Only certain 3174 diskettes can be copied onto a fixed disk and only one of each diskette type can reside on the fixed disk at a time. For example, two Utility diskettes cannot be copied to the fixed disk. The second copy will overwrite the first copy.

When diskettes are copied to a fixed disk, they become subdirectories on the fixed disk and are automatically named by the control unit. Names given by the control unit are reserved subdirectory names and are unalterable.

The following diskettes can be copied to the fixed disk:

3174 Diskette	Reserved Subdirectory Name
Utility	UTL00001
Control	CTL00001
Limited Function Utility	LFU00001
Library	LIB00001
Downstream Load	DSL00001

Notes:

1. The Utility and Control diskettes must be at or greater than microcode level A4.0 or S4.0.
2. The DSL subdirectory for this diskette can contain microcode for up to four of the following: 3290, 3179-G, 3192-G, 3193, and 3174 Feature 3020 - AEA.
3. If you are using Central Site Change Management, See "CSCM Fixed Disk 3174 Setup" in the *Central Site Customizing User's Guide*, GA23-0342, for recommendations on copying the Control disk.

Warning: When both the Utility and the Limited Function Utility diskettes are copied to the fixed disk, the system will IML from the one most recently copied. For example, if you copy the Limited Function Utility diskette to the fixed disk first and then copy the Utility diskette to the fixed disk, the Utility disk is used for the IML. This can be overridden by performing the Procedure for Selecting the IML Source in Chapter 18, "How to Perform Media Management."

Note: Although the RPQ diskette cannot be copied to the fixed disk, individual RPQs can be merged to the UTL00001 subdirectory and then transferred to the CTL00001 subdirectory.

A Fixed Disk Drive as the From Drive

When specifying a fixed disk drive as the *From* drive, you will be presented with a panel that requests you to choose a subdirectory and press ENTER. See Figure 15-3.

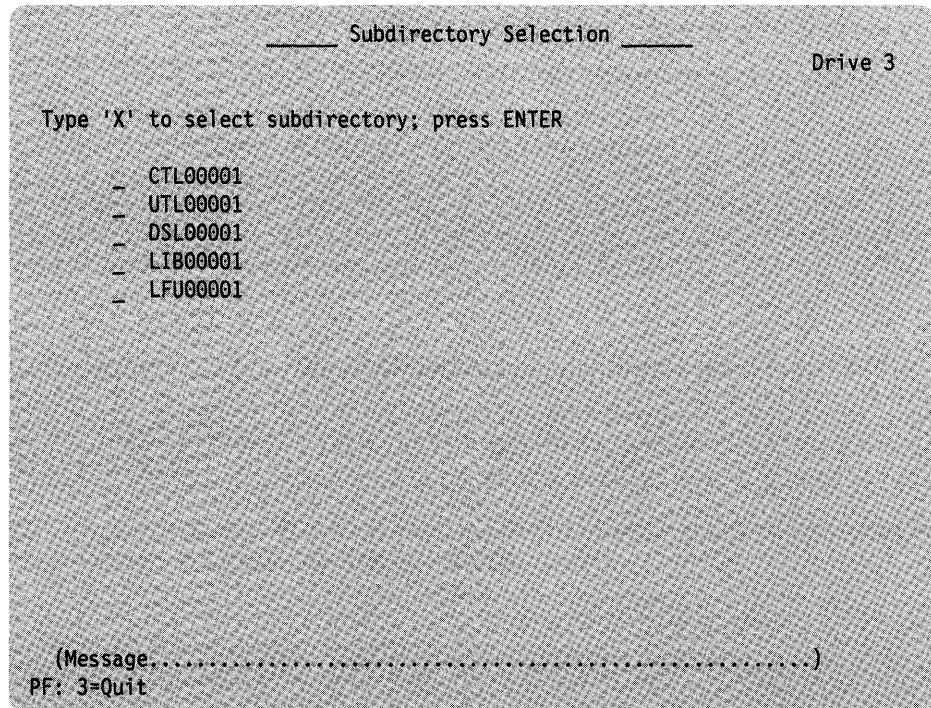

Figure 15-3. Subdirectory Selection. The drive specified as the *From* drive and the subdirectories that reside on that drive are presented on this panel.

This panel will display all of the subdirectories (3174 diskettes) that reside on the fixed disk you have specified as the *From* drive. Only one subdirectory can be selected at a time.

How to Determine Maintenance and Microcode Levels

When a copy involves a diskette, you will need to know the maintenance and microcode levels of the diskette. The exception to this is Full Copy. A label in the upper portion of a diskette identifies the diskette type by name, IBM part number, validation number, maintenance and microcode levels. The maintenance and microcode levels appear in the format shown in Figure 15-4.

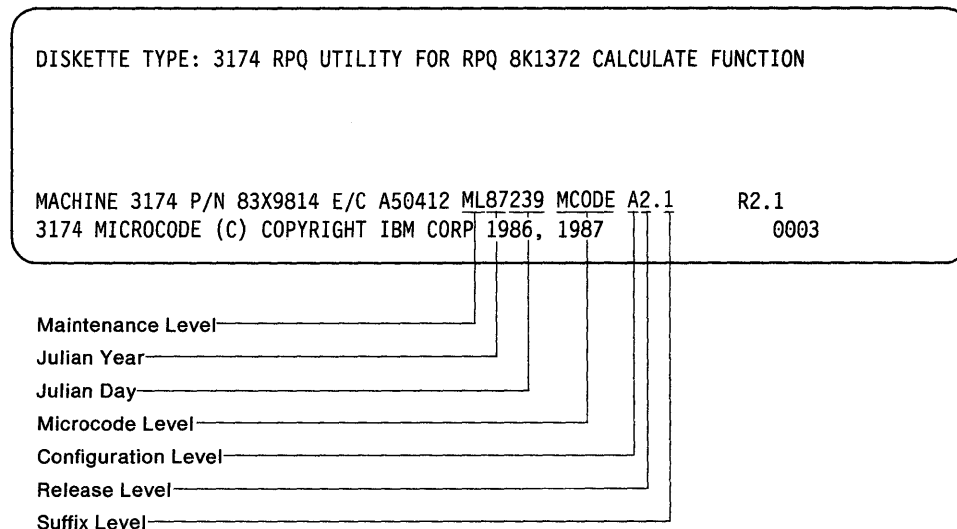

Figure 15-4. The Maintenance and Microcode Levels. The maintenance level represents the Julian date, where 87 is the year and 239 is the day of the year (87239 is August 27, 1987). The microcode level consists of configuration, release, and suffix levels.

To determine the microcode level of a diskette, you compare the sequence of letters and numbers. For example, a diskette with a microcode level of A2.1 has a lower level of microcode than a diskette with a microcode level of A3.2.

Full Copy

During a Full Copy, you copy the entire contents of a Utility, Control, DSL, LIB or LFU disk onto a fixed disk or a two-sided, high-density diskette. Full Copy can also be used to copy the RPQ diskette to a two-sided, high-density diskette. (Unformatted diskettes are automatically formatted during the Copy procedure.)

When performing a Full Copy, keep in mind that:

- A fixed disk can contain only one Utility, Control, DSL, LIB, and LFU disk. For example, two Control disks cannot be copied to the fixed disk. The second copy will overwrite the first.
- Backup and On-trial versions will not be copied. (See the *Central Site Customizing User's Guide*, GA23-0342, for more information on Backup and On-trial versions.)
- When copying a LIB disk from a fixed disk, all library members will be copied. When copying a LIB disk from a diskette to a fixed disk, only unique library members will be copied.
- A fixed disk can store a greater number of library members than a diskette, therefore, more than one diskette may be required to hold the LIB disk contents stored on a fixed disk. If you are copying a LIB disk from a fixed disk to a diskette and the number of members exceeds the diskette storage space, you will be prompted to insert another diskette.
- A Full Copy requires a 3174 control unit with two disk drives.

You can also copy the customizing responses of a Control disk by using the Copy Customizing Data option. This procedure is faster than a Full Copy because only the regular configuration responses, patches, RPQs, modified keyboards, PAM, and AEA configuration responses are copied.

The logs from the original control disk are copied during a Full Copy. It is recommended that you IML the copied disk and perform a Reset Log/Test 4 on it to reset all the logs. This procedure is described in the *Customer Extended Problem Determination*, GA23-0217. Performing this test procedure will facilitate problem determination on the duplicate control disk.

Before you start, you will need the following:

- *From* disk: A Utility, Control, DSL, RPQ, LIB, or LFU disk. This is the disk you are copying from.
- *To* disk: A fixed disk or two-sided, high-density diskette (formatted or unformatted). This is the disk you are copying to.
- If using a diskette, a *label* indicating the new microcode level of the *To* diskette.

Go to "Copy Procedure" on page 15-11 to perform Full Copy.

Modify and Copy

During a Modify and Copy, you can modify certain configuration responses of a control disk as you are copying it to another disk. The disk that you copy to can serve as the control disk for another control unit. This modification will not change the original control disks information, but instead will modify certain responses for the new control disk.

Note: A Modify and Copy requires a 3174 control unit with two disk drives.

You can modify the responses to these configuration questions:

- 099: Assistance Data
- 104: Control Unit Address
- 105: Upper Address Limit (Non-SNA or the Token-Ring Network 3270 Gateway feature)
- 106: Token-Ring Network Address of the 3174 (Token-Ring Network)
- 107: Token-Ring Network Address of the Gateway (Token-Ring Network)
- 108: Unique Machine Identifier
- 215: Physical Unit Identification.

Notes:

1. Question 105 appears only if you are modifying local non-SNA and the Token-Ring Network 3270 Gateway feature configuration data.
2. Questions 106 and 107 appear only if you are modifying Token-Ring configuration data.
3. If you have the Token-Ring Network 3270 Gateway feature, the new subchannel range (questions 104 and 105) cannot be greater than the previously defined range.

Before you start, you will need the following:

- *From* disk: A customized Control disk with the same *microcode level* as the Utility disk that was IMLed. This is the disk you are copying from.
- *To* disk: A fixed disk or a two-sided, high-density diskette (formatted or unformatted). This is the disk you are copying to.
- If using a diskette, a *label* indicating the new microcode level of the *To* diskette.

Go to "Copy Procedure" on page 15-11 to perform Modify and Copy.

Copy Customizing Data

This procedure copies only the regular configuration responses, patches, RPQs, modify keyboard tables, PAM, and AEA configuration responses from one Control disk to another Control disk of the same microcode level. During this procedure, all existing configuration responses, patches, RPQs, modified keyboards, and the PAM on the *To* disk are replaced by the configuration responses (regular and AEA), patches, RPQs, modified keyboards, and the PAM on the *From* disk. This method of duplicating customized Control disks is faster than the Full Copy.

Before you start, you will need the following:

- *From* disk: A customized Control disk of the same *microcode level* and *maintenance level* as the *To* disk and the same *microcode level* as the IMLed Utility disk. This is the disk you are copying from.
- *To* disk: A Control disk of the same *microcode level* and *maintenance level* as the *From* disk. This is the disk you are copying to.

Go to "Copy Procedure" on page 15-11 to perform Copy Customizing Data.

Copy PAM

During a Copy PAM, you copy only the PAM file from one Control disk to another Control disk of the same configuration and release levels. Doing this will erase any PAM found on the *To* disk.

Before you start, you will need the following:

- *From* disk: A Control disk with the Printer Authorization Matrix (PAM) defined, and of the same *microcode level* as the IMLed Utility disk. This is the disk you are copying from.
- *To* disk: A Control disk of the same *configuration and release levels* as the *From* disk and the IMLed Utility disk. *The To disk must be configured for the PAM either before or after the copy is made.* This is the disk you are copying to.

Go to "Copy Procedure" on page 15-11 to perform Copy PAM.

Copy Patches

During a Copy Patches procedure, you copy only the patch files from one Control disk to another Control disk of the same microcode level or from one Utility disk to another Utility disk of the same microcode level. Doing this will erase any patches found on the *To* disk.

Before you start, you will need the following:

- *From* disk: A Control disk with patch data merged onto it and of the same *microcode level* and *maintenance level* as the *To* disk and of the same *microcode level* as the IMLed Utility disk. This is the disk you are copying from.
- *To* disk: A Control disk of the same *microcode level* and *maintenance level* as the *From* disk and the same *microcode level* as the IMLed Utility disk. This is the disk you are copying to.

Go to "Copy Procedure" on page 15-11 to perform Copy Patches.

Copy Modified Keyboards

During a Copy Modified Keyboards procedure, you copy only the Modified Keyboard tables from one Control disk to another Control disk of the same configuration and release level. Doing this will erase any Modified Keyboard tables found on the *To* disk.

Before you start, you will need the following:

- *From* disk: A Control disk with Modified Keyboard tables defined on it and of the same *microcode level* as the IMLed Utility disk. This is the disk you are copying from.
- *To* disk: A Control disk of *the same configuration and release levels* as the *From* disk and the IMLed Utility disk. This is the disk you are copying to. *The To disk must be configured for the Modify Keyboards procedure either before or after the tables are copied; language specifications within the Modified Keyboards tables may differ from the From disk.*

Go to "Copy Procedure" on page 15-11 to perform Copy Modified Keyboards.

Copy RPQs

During Copy RPQs, you copy only the RPQ files from one Control disk to another Control disk. Doing this will erase any RPQs found on the *To* disk.

Before you start, you will need the following:

- *From* disk: A Control disk with RPQ data merged on it. This disk must have the same *microcode level* as the IMLed Utility disk. This is the disk you are copying from.
- *To* disk: A Control disk of the same *configuration level* as the IMLed Utility disk and a release level that *is equal to or greater than* the IMLed Utility disk. This is the disk you are copying to.

Go to "Copy Procedure" on page 15-11 to perform Copy RPQs.

Copy Procedure

The following sequence of steps should be used when you are performing any of the copy procedures. Before performing a copy procedure, go to the description of the type of copy you wish to perform and review the items you will need before starting.

PF Keys

You call up a specific function of the customizing program by pressing a PF key. A PF key is operational only if it appears on the panel you are using. PF3 appears on the panels you use during the Copy procedure:



PF: 3=Quit

PF3 PF3 (Quit) quits the procedure without saving any responses since the last ENTER key was pressed. Then the Copy Menu appears on your screen. Pressing PF3 again takes you out of the copy procedure and displays the Master Menu on your screen.

Note: Keyboards with PF13 through 24 are mapped into PF1 through 12. For example, PF13 is PF1 and PF16 is PF3.

Step 1. Select 'Copy Files' on the Master Menu

1-1: Display the Master Menu. (See Chapter 12, "How to Display the Master Menu," for directions.)

1-2: Type 3 after Select == =>



Select ===> 3

1-3: Press ENTER on the keyboard.

Step 2. Select the Copy Procedure from the Copy Menu

The Copy Menu (Figure 15-5) appears on your screen.

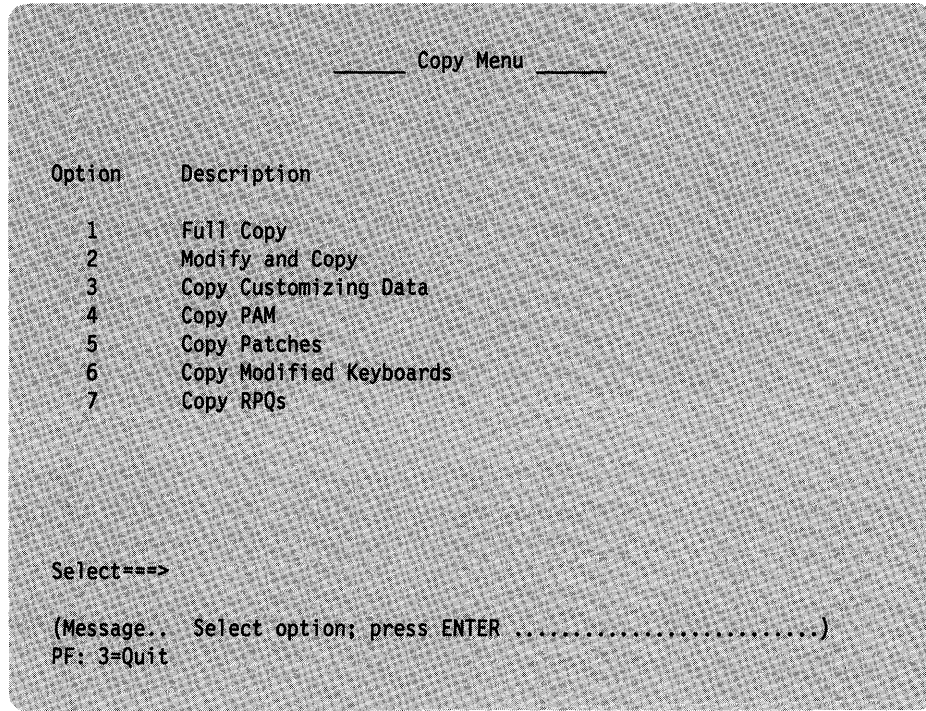

Figure 15-5. Copy Menu. Select a copy option from this screen.

2-1: Select and type an option number after Select = = = >

2-2: Press ENTER.

Step 3. Verify Drives

The prompt in Figure 15-6 appears at the bottom of the screen with the option you selected highlighted. **Available drives** appears in place of **Select = = = >**.

Available drives: 1 2 3 4 From = = = > 1 To = = = > 2

Figure 15-6. Available Drives Prompt. The **available drives** listed are 1 through 4. The responses for the *From* and *To* drives contain default drive selections. In this example, the default drive selections are 1 and 2 respectively.

What happens next depends on the number of drives available to the control unit.

For a Control Unit with One Disk Drive

Note: Full Copy and Modify and Copy require two diskette drives.

The From = = = > and To = = = > drive fields are both defaulted to 1.

A message to insert diskettes for copying appears on the message line near the bottom of your screen.

3-1: Insert the *From* diskette, close the drive, and press ENTER. A message informs you of the progress of the Copy procedure.

3-2: A message to remove the *From* diskette and insert the *To* diskette appears on the message line near the bottom of your screen. Remove the *From* diskette, insert the *To* diskette, and press ENTER.

A message appears on the message line while the copying is being performed. It will indicate the progress of the Copy procedure. You will receive a message when copying is completed.

For a Control Unit with More Than One Disk Drive

The From = = = > and To = = = > drive fields contain default drive selections.

If you do not want to use the default drive selections, after From = = = >, type the number for the *From* drive. After To = = = >, type the number for the *To* drive.

3-1: Press ENTER. The drives that you selected are highlighted on your screen.

3-2: If you specified a **diskette drive** as the *From* or *To* drive, a message to insert the diskette for copying appears on the message line near the bottom of your screen. Insert the *From* or *To* diskette, close the drive door, and press ENTER.

3-3: If you specified a **fixed disk drive** as the *From* drive, you will be presented with the Subdirectory Selection panel (See Figure 15-7 on page 15-14).

Note: Only one subdirectory can be copied at a time.

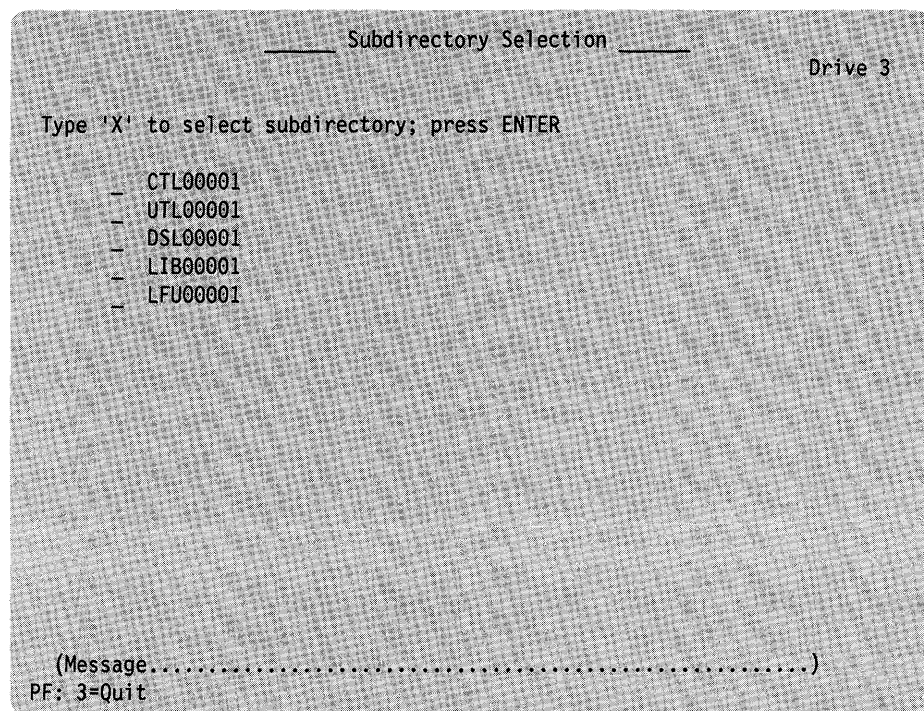

Figure 15-7. Subdirectory Selection

Type an **X** next to the subdirectory name that you want to be copied, and press ENTER.

A message appears on the message line while the copy is performed. It indicates the processing of the Copy procedure. If you are copying from a fixed disk to a diskette, you will be prompted for any additional diskettes required. You will receive a message when copying is completed.

Step 4. Define the Modified Responses (for Modify and Copy Only)

After you verify your *From* and *To* drives (Figure 15-2 on page 15-4) for the Modify and Copy procedure, another panel appears (Figure 15-8). On this Modify and Copy panel, you can modify the responses entered on the *From* disk.

```

_____ Modify and Copy _____

'From' drive (n) responses:

099 - XXXXXXXXXXXXXXXXXXXXXXXX
104 - XXXXX
105 - XXXX
108 - XXXXXXX
215 - XXXXX

'To' drive (n) responses:

099 - XXXXXXXXXXXXXXXXXXXXXXXX
104 - XXXXX
105 - XXXX
108 - XXXXXXX
215 - XXXXX

(Message.....)
PF: 3=Quit

```

Figure 15-8. The Modify and Copy Panel. On this example panel, you can modify responses to five configuration questions. Here the Xs represent the responses from the *From* disk, which appear on the panel. The *n* represents the number of the drive, which appears on the panel.

In the top half of the panel, the responses previously entered on the *From* disk are displayed. In the bottom half of the panel, you enter only the responses you want to change.

4-1: In the *To* drive fields, type over the responses you want to modify. If you wish, you can leave a response unchanged.

4-2: Press ENTER.

A message appears on the message line while the copying is being performed. It will indicate the processing of the Copy procedure. You will receive a message when copying is completed.

Step 5. Make Multiple Copies of the From Disk

5-1: After the Copy is completed, a message prompts you to make another copy.

If copying to a **fixed disk drive:**

1. Press PF3 to quit.

The Copy Menu appears on your screen.

If copying to a **diskette drive:**

1. Insert a *To* diskette for each copy you want to make.
2. Press ENTER.

When you do not want to make any more copies of this *From* diskette, press PF3. The Copy Menu appears on your screen.

What's Next?

The Copy Menu is on your screen.

You can:

- Select a different Copy procedure from the Copy Menu.

Note: Be sure to refer to the description of the type of copy you wish to perform and review the items you will need before starting.

- Remove any diskettes from the drives if you have completed performing all the copy procedures you wished to perform.

Note: Identify any diskettes copied by writing a unique designation on the label; you must include the **Configuration and Release level Information** on the label and you may want to identify the specific control unit in which the diskette is to be used.

- Return to the Master Menu by pressing the PF3 key and choose another customizing procedure. See the "3174 Quick-Reference Guide for Customizing" to locate the information for the procedure you have chosen or to determine the next procedure to perform.
- If this is the last customizing procedure you are performing and you are ready to put the control unit online, proceed to the IML procedure listed in the *3174 User's Guide* for the control unit model you are using.

Chapter 16. How to Upgrade Microcode

Getting Ready to Upgrade Microcode	16-3
An Overview of the Microcode Upgrade Procedure	16-3
How to Determine Maintenance and Microcode Levels	16-4
The Microcode Upgrade Panel	16-5
Microcode Upgrade Procedure	16-6
PF Keys	16-6
Step 1. Select 'Microcode Upgrade' on the Master Menu	16-6
Step 2. Verify Drives	16-7
Step 3. Upgrading the Microcode	16-8
Step 4. Make Multiple Upgrades of Control Disks	16-9
What's Next?	16-9

Getting Ready to Upgrade Microcode

Before you start, you will need the following:

- The identity of the customizing keyboard. If you do not have this information, see Chapter 19, "How to Identify Customizing Keyboards."
- *From* disk: A customized Control disk. This disk is referred to as the *Old* disk. The customizing data on the Old disk will be transferred to the New disk.
- *To* disk: A Control disk that is referred to as the *New* disk. This disk must have the same configuration level and the same or higher release, suffix, and maintenance levels as the Old disk.
- A Utility disk: This disk must have the same microcode level as the New (*To*) disk.

If the suffix levels of the Old and New disks are equal, the maintenance level of the New disk must be equal to or higher than the maintenance level of the Old disk. (See "How to Determine Maintenance and Microcode Levels" on page 16-4.)

An Overview of the Microcode Upgrade Procedure

Periodically, IBM may issue upgraded Utility and Control diskettes. An upgraded diskette may incorporate new maintenance enhancements and/or new function into the 3174 Subsystem Control Unit that has been previously customized. The Microcode Upgrade procedure transfers the customizing data (configuration responses, PAM data) on a previously customized Control disk (*Old* disk) to the New, higher-microcode-level disk and copies the existing RPQ data. The transferred customizing data replaces the corresponding responses on the New disk. The copied data replaces the corresponding responses on the New disk, **but it is not upgraded**. Refer to Table 16-1 for information on which procedures may have to be performed **after** the Microcode Upgrade procedure. Note that you can upgrade only to the same or *higher* microcode level. This procedure saves you time because you do not have to recustomize the New disk for configuration responses or the PAM.

Note: Patches are **not** moved during the Microcode Upgrade procedure. Patches on the New (*To*) disk remain intact.

Customizing Data Type	Procedure	Refer To
RPQ	Merge RPQs	Chapter 13
Modify Keyboard tables	Modify Keyboards	Chapters 11 and 13
DSL	Merge DSL	Chapter 14

How to Determine Maintenance and Microcode Levels

You will need to know the maintenance and microcode levels of a diskette if you use the Microcode Upgrade procedure. A label in the upper portion of a diskette identifies the diskette type by name, IBM part number and validation number, microcode level, and maintenance level. The maintenance and microcode levels appear in the format shown in Figure 16-1.

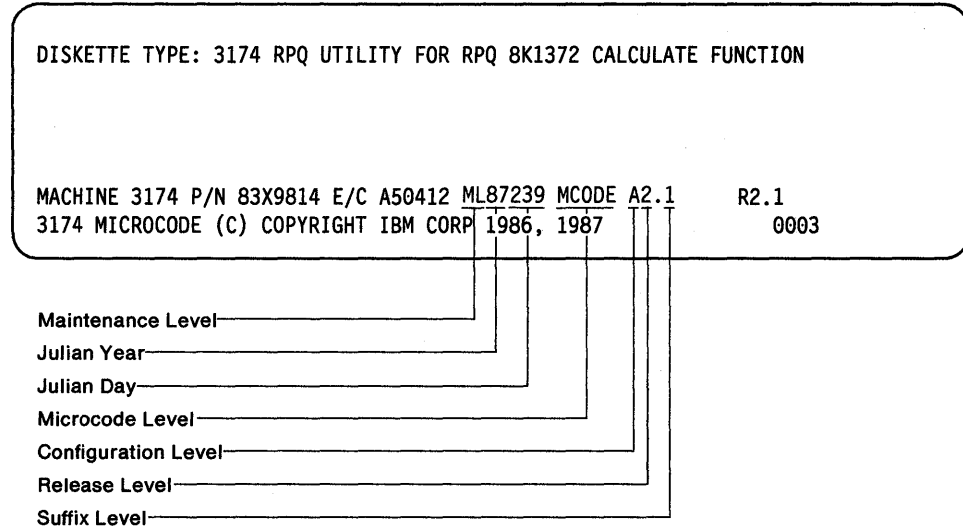

Figure 16-1. The Maintenance and Microcode Levels. The microcode level consists of configuration, release, and suffix levels. The maintenance level consists of the Julian date, where 87 is the year and 239 is the day of the year (87239 is August 27, 1987).

To determine the microcode level of a diskette, you compare the sequence of letters and numbers. For example, a diskette with the level A2.1 has a lower level of microcode than a diskette with a microcode level of A3.2.

Note: If you have the IBM Token-Ring Network 3270 Gateway feature, use the 3174 Utility and Control disks at Configuration Level S; otherwise, use the 3174 Utility and Control disks at Configuration Level A.

The Microcode Upgrade Panel

After you select "Microcode Upgrade" on the Master Menu, the Microcode Upgrade panel (Figure 16-2) appears on your screen.

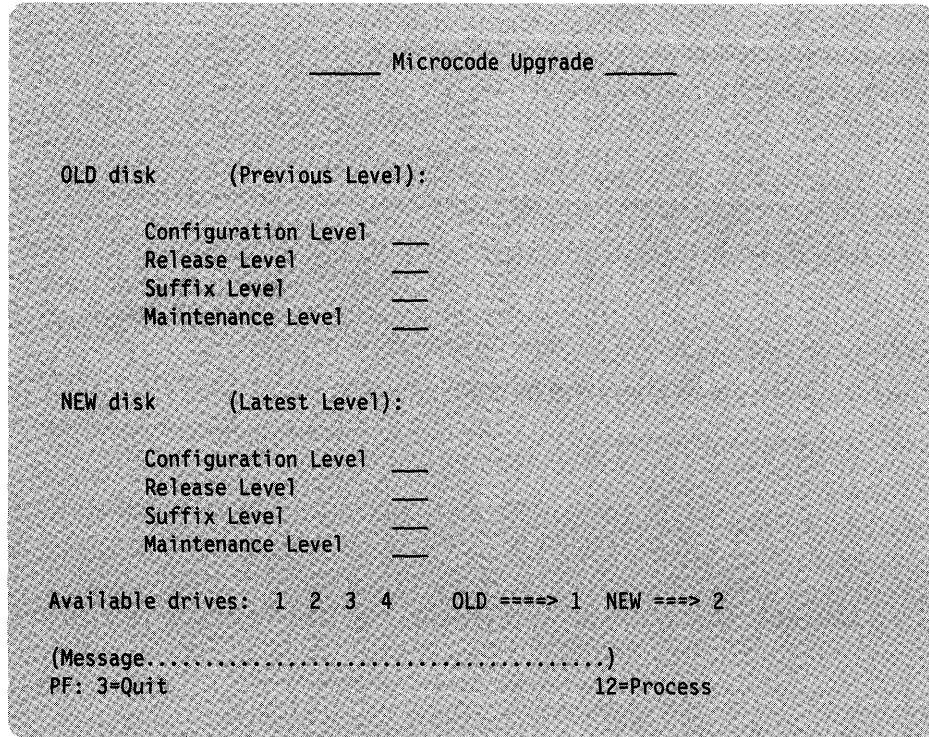

Figure 16-2. Microcode Upgrade Panel

The fields under the *Old* and *New* heading will display microcode information. (If diskette drives are selected, the diskettes have to be inserted before the microcode information will appear.) This panel tells you how many drives you have available and allows you to verify the numbers that define your Old (*From*) and New (*To*) drives.

Microcode Upgrade Procedure

The following sequence of steps should be used when performing an upgrade.

PF Keys

You call up a specific function of the customizing program by pressing a PF key.

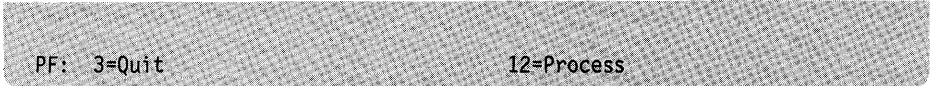

PF: 3=Quit

12=Process

PF3 PF3 (Quit) quits the Microcode Upgrade procedure without saving any responses since the PF12 key was last pressed. Then, the Master Menu appears on your screen.

PF12 PF12 (Process) initiates the microcode upgrading process. If you are using a Data Entry, Data Entry Keypunch, or non-QWERTY keyboard without PF12, use PA2.

Note: Keyboards with PF13 through 24 are mapped into PF1 through 12. For example, PF13 is PF1 and PF16 is PF3.

Step 1. Select 'Microcode Upgrade' on the Master Menu

1-1: Display the Master Menu by performing an ALT 1 IML using a Utility disk that has the same microcode level as the New (To) disk. (See Chapter 12, "How to Display the Master Menu," for instructions.)

1-2: Type **5** after Select ===> .



Select ===> 5

1-3: Press ENTER on the keyboard.

Step 2. Verify Drives

The Microcode Upgrade panel (Figure 16-3) is on your screen.

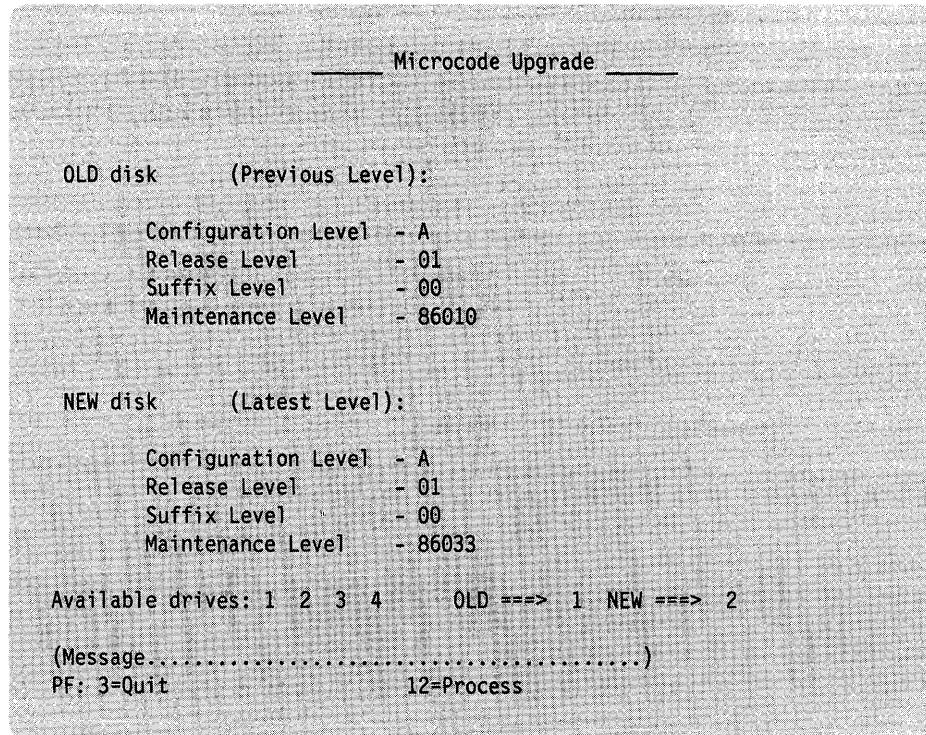

Figure 16-3. Microcode Upgrade Panel for Selecting Drives. The configuration, release, suffix, and maintenance levels of the disks are displayed. (If you select a diskette drive, the diskette must be inserted before any information will be displayed.) This example shows a four-drive control unit.

What happens next depends on the number of drives available to the control unit.

How to Upgrade Microcode

For a Control Unit with One Disk Drive

The responses to `Old === >` and `New === >` are defaulted to 1.

2-1: Insert the Old diskette, close the drive, and press ENTER. This procedure will check to make sure the Old diskette is valid. If so, the product level information will appear on the panel under the *Old* heading.

A message to insert the New diskette appears on the message line near the bottom of your screen.

2-2: Remove the diskette.

2-3: Insert the New higher-level microcode upgrade diskette, close the drive, and press ENTER. This procedure will check to make sure the microcode diskette is valid. If so, the product level information will appear on the panel under the *New* heading.

Go to Step 3.

For a Control Unit with More Than One Disk Drive

The *Old* and *New* drive fields contain default drive selections.

If you do not want to use the default drive selections, after `Old === >` , type the number for the old drive. After `New === >` , type the number for the new drive.

2-1: Press ENTER. The *Old* and *New* drives that you selected are highlighted on your screen.

2-2: If you specified a **diskette drive(s)** for the *Old* and/or *New*, a message to insert the diskette(s) for upgrading appears on the message line near the bottom of your screen. Insert the Old and/or New diskette(s), close the drive(s), and press ENTER.

This procedure will check to ensure that the Microcode disk is valid. If so, the product level information will appear on the panel under the appropriate fields.

Step 3. Upgrading the Microcode

3-1: Press PF12 to initiate the upgrade of the microcode.

A message will appear near the bottom of the screen, indicating when the upgrading is completed.

Step 4. Make Multiple Upgrades of Control Disks

4-1: If upgrading to a **fixed disk drive**:

A message appears informing you that upgrading is complete.

- Press PF3 to quit.

The Master Menu appears on your screen.

If upgrading to a **diskette drive**:

After upgrading is complete, a message appears that prompts you to continue to upgrade.

1. Insert another Old or New diskette for each upgrade you want to make.

Note: If the microcode level and maintenance levels of the multiple Control diskettes are the same, use the copy configure capability of the Copy procedure. See Chapter 15, "How to Copy Files" for more information on the copy procedures.

2. Press ENTER. The configuration, release, suffix, and maintenance levels of the diskette you inserted are displayed.
3. Press PF12 to initiate the upgrade of the microcode. A message will appear near the bottom of the screen, indicating when the upgrading is completed.

4-2: When you do not want to upgrade any more diskettes:

1. Remove any diskettes.
2. Ensure that the **original** Utility disk is in the IMLed drive.
3. Press PF3. The Master Menu appears on your screen.
4. Go to "What's Next?"

What's Next?

The Master Menu is on your screen.

You can:

- Select a different customizing procedure from the Master Menu. See the "3174 Quick-Reference Guide for Customizing" to locate the information for the procedure you have chosen or to determine the next procedure to perform.
- Exit customizing. Remove any diskettes used for the Upgrade procedure from the drives.
- Identify any diskettes by writing a unique designation on the label; for example, you could identify the configuration of the diskette and the 3174 control unit in which it is to be used.
- To put the 3174 online, IML with the Control disk that you use for normal operations (perhaps the one you just upgraded).

Chapter 17. How to Initialize the Encrypt/Decrypt Feature

Getting Ready to Initialize the Encrypt/Decrypt Feature	17-3
An Overview of Encrypting/Decrypting	17-3
Encrypt/Decrypt Procedure	17-5
PF Keys	17-5
Step 1. Select 'Encrypt/Decrypt Master Key' on the Master Menu	17-5
Step 2. Verify Drives	17-6
Step 3. Select an Option	17-7
Option 1: Enter the Master Key Value	17-8
Step 1. Insert the Security Key	17-8
Step 2. Select Option 1 from the Encrypt/Decrypt Utility Panel	17-8
Step 3. Fill In the Panel	17-9
What's Next?	17-10
Option 2: Display the Verification Pattern	17-11
Step 1. Select "Option 2" from the Encrypt/Decrypt Menu	17-11
What's Next?	17-12
Option 3: Verify the Master Key Value	17-13
Step 1. Select Option 3 from the Encrypt/Decrypt Utility Panel	17-13
What's Next?	17-14
Option 4: Test the Encrypt/Decrypt Feature	17-15
Step 1. Insert the Security Key	17-15
Step 2. Select Option 4 from the Encrypt/Decrypt Utility Panel	17-15
What's Next?	17-17

Getting Ready to Initialize the Encrypt/Decrypt Feature

Before you start, you will need the following:

- The identity of the customizing keyboard. See Chapter 19, "How to Identify Customizing Keyboards."
- An installed Encrypt/Decrypt Adapter.
- An Encrypt/Decrypt diskette.

An Overview of Encrypting/Decrypting

The Encrypting/Decrypting procedure protects data from unauthorized disclosure by encrypting (encoding) data sent from the 3174 Subsystem Control Unit to the host system and by decrypting (decoding) data received from the host. Therefore, only authorized persons should use this procedure. The process is possible when an Encrypt/Decrypt feature is installed in 3174 Models 1R, 2R, and 3R. For instructions on how to install the feature, see the *Encrypt/Decrypt Adapter Customer Setup Instructions*, GA23-0262, which accompanies this feature.

It is useful to know the following terms:

Encrypt/Decrypt feature: Consists of an Encrypt/Decrypt diskette, a security key, and an adapter. The adapter is installed in 3174 Models 1R, 2R, and 3R. It protects information, like a safe.

Master Key Value (MKV): Makes the Encrypt/Decrypt feature operational. It is made up of 16 characters between the numbers 0 through 9 and the letters A through F. The characters entered for the MKV are hexadecimal characters. Each byte of the key-variable, consisting of two of these hexadecimal characters, must have odd parity. This means that the number of 1 bits in that byte of the key-variable must be odd.

An authorized person enters the MKV into the adapter by typing it at a display terminal attached to port 0 of 3174 Models 1R, 2R, and 3R. The MKV is loaded and stored into the adapter. To ensure the security of the MKV, it is not displayed on the screen. By checking the *status* of the MKV, however, you can determine the security of your data.

Checking the status of the MKV is easy to do and does not require knowing the MKV itself. Any authorized person, therefore, can check the status of the MKV without breaching its security. If the MKV has been changed without authorization, you know that the security of your data communication may have been breached.

Verification Pattern (VP): Is a representation of the MKV that is displayed on the screen. By looking at the VP, you can determine whether the MKV has been changed without authorization. This will help you determine whether the MKV's security has been breached.

The 3174 calculates a unique VP automatically each time a new MKV is loaded into the adapter.

Initializing Encrypt/Decrypt

Control Unit ID (CID): Is the value designated by your organization that identifies the control unit that is encrypting or decrypting data. It should not be confused with the control unit address. It consists of 1 to 8 characters between the numbers 0 through 9 and the letters A through F. The CID is entered from the keyboard. Odd parity is not required.

Encrypt/Decrypt: Is a procedure you can select from the Master Menu. You can enter an MKV, check its status, and test the Encrypt/Decrypt feature. After the Encrypt/Decrypt procedure is selected from the Master Menu, the Encrypt/Decrypt Utility panel (Figure 17-1) is displayed.

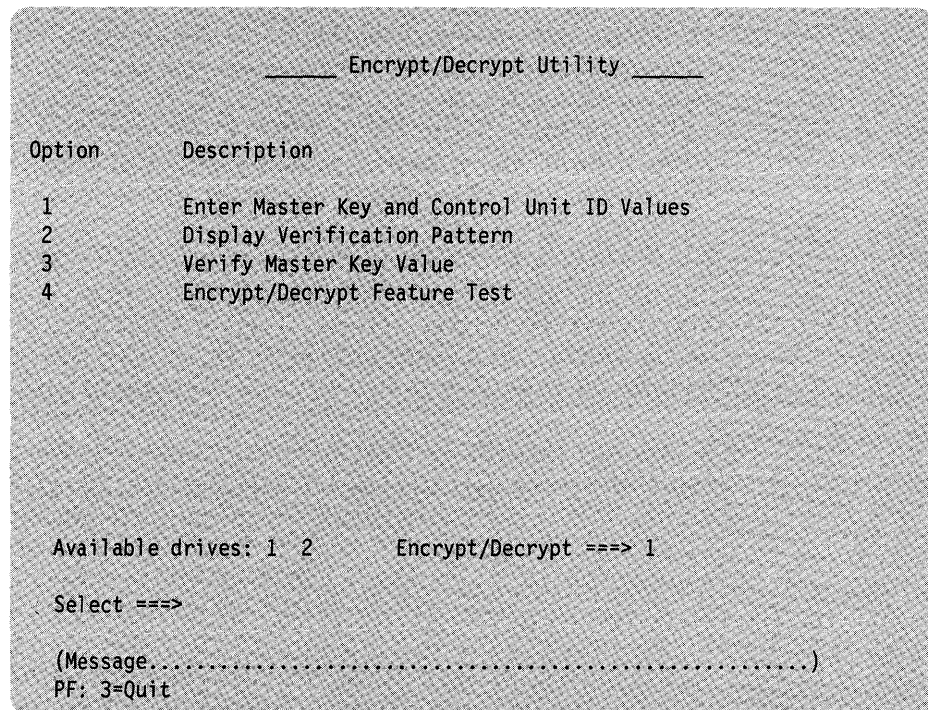

Figure 17-1. Encrypt/Decrypt Utility Panel. This panel tells you how many diskette drives you have available and allows you to verify or select the diskette drive that contains your Encrypt/Decrypt diskette. The Encrypt/Decrypt = = = > drive field appears with a default drive selection. This default drive selection can be changed.

Note: The Encrypt/Decrypt procedure can only be performed using a diskette drive.

From this panel, you can select from four options:

Option 1: Initialize or change the master key value

Option 2: Display the verification pattern

Option 3: Verify the security of the master key value

Option 4: Test the proper functioning of the Encrypt/Decrypt feature. This should be done *before* the first MKV is entered. Using this option destroys any MKV in the adapter.

Encrypt/Decrypt Procedure

The following sequence of steps should be used to invoke the Encrypt/Decrypt Utility panel.

PF Keys

You call up a specific function of the customizing program by pressing a PF key. A PF key is operational only if it appears on the panel you are using.



PF3 PF3 (Quit) quits this procedure without saving any responses since the last ENTER key or PF12 was pressed. Then the Encrypt/Decrypt Utility panel appears on the screen. Pressing PF3 twice in succession takes you out of the procedure and displays the Master Menu on your screen.

PF12 PF12 (Process) processes the options specified during this procedure. If you are using a Data Entry, Data Entry Keypunch, or non-QWERTY keyboard without PF12, use PA2.

Step 1. Select 'Encrypt/Decrypt Master Key' on the Master Menu

1-1: Display the Master Menu. (See Chapter 12, "How to Display the Master Menu" for directions.)

1-2: Type **6** after Select = = = >



1-3: Press ENTER.

Initializing Encrypt/Decrypt

Step 2. Verify Drives

The Encrypt/Decrypt Utility panel (Figure 17-2) is displayed on the screen.

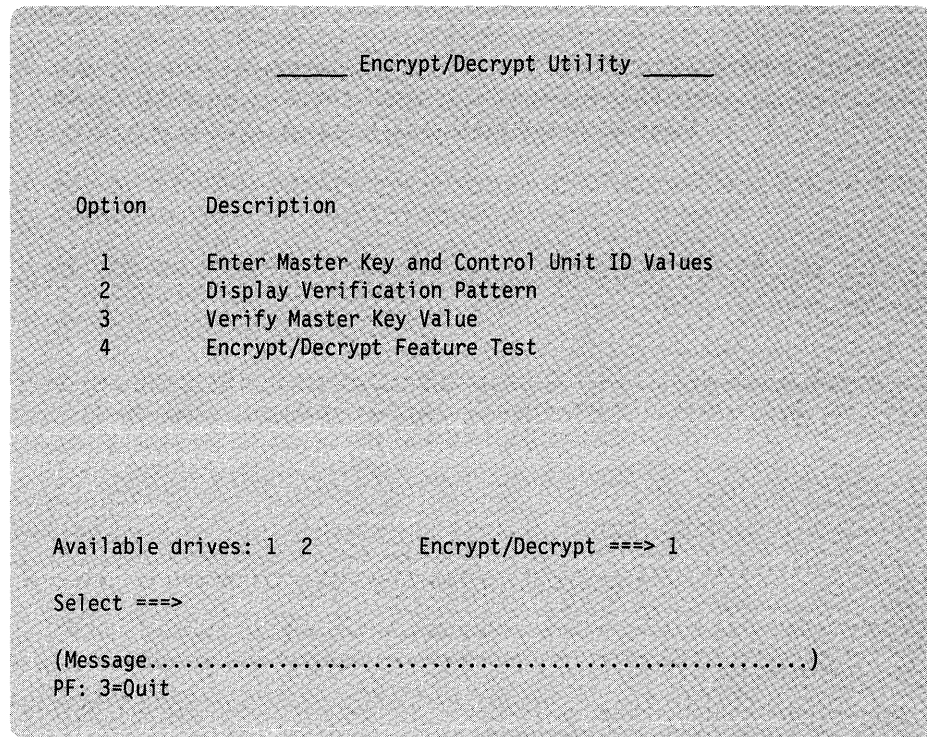

Figure 17-2. Encrypt/Decrypt Utility Panel with drive selection. From this panel, you can verify the drive selection and select an Encrypt/Decrypt option.

What happens next depends on the number of drives available to the control unit.

For a Control Unit with One Disk Drive

The Encrypt/Decrypt == > drive field is defaulted to 1.

2-1: Remove the Utility diskette, insert the Encrypt/Decrypt diskette, and close the drive.

2-2: Press ENTER. A message prompts you to select an option.

2-3: Go to “Step 3. Select an Option” on page 17-7.

For a Control Unit with More than One Disk Drive

The Encrypt/Decrypt == => drive field contains a default drive selection. A message requests that you verify this selection.

If you do not want to use the default drive selection, type the number of the drive that you want to use after Encrypt/Decrypt == => .

Note: Only a diskette drive number is valid for the Encrypt/Decrypt drive.

2-1: Press ENTER. The drive selected is highlighted on your screen.

A message on the screen prompts you to insert an Encrypt/Decrypt diskette into the drive specified.

2-2: Insert the Encrypt/Decrypt diskette and close the drive.

2-3: Press ENTER. A message prompts you to select an option.

Step 3. Select an Option

If you want to:	Go to:
Initialize or change the MKV	"Option 1: Enter the Master Key Value" on page 17-8
Check the status of the VP	"Option 2: Display the Verification Pattern" on page 17-11
Ensure the security of the MKV	"Option 3: Verify the Master Key Value" on page 17-13
Test for the proper functioning of the feature	"Option 4: Test the Encrypt/Decrypt Feature" on page 17-15

If you are ready to select an option, turn to the procedure.

Option 1: Enter the Master Key Value

You Need:

- The Adapter security key
- A master key value (MKV)
- A control unit ID.

With this option, you can initialize or change the master key value and store it in the Encrypt/Decrypt Adapter.

You should perform this procedure only if you are authorized to enter the MKV. Contact the appropriate person in your organization to obtain the MKV and the control unit ID.

Step 1. Insert the Security Key

1-1: If the security key is not inserted in the 3174 security keylock, obtain the key from the appropriate person in your organization and insert the key in the keylock.

Warning: Turning the security key to the vertical (on) position when the 3174 is turned off will cause the loss of the master key value.

1-2: Make sure the security keylock is in the fully clockwise (vertical) position; if it is not, turn the key clockwise to the vertical position.

Step 2. Select Option 1 from the Encrypt/Decrypt Utility Panel

The Encrypt/Decrypt Utility panel is displayed on the screen. (See Figure 17-2 on page 17-6.)

2-1: Type **1** after Select == =>



2-2: Press ENTER. The Encrypt/Decrypt MKV/CID panel is displayed. See Figure 17-3 on page 17-9.

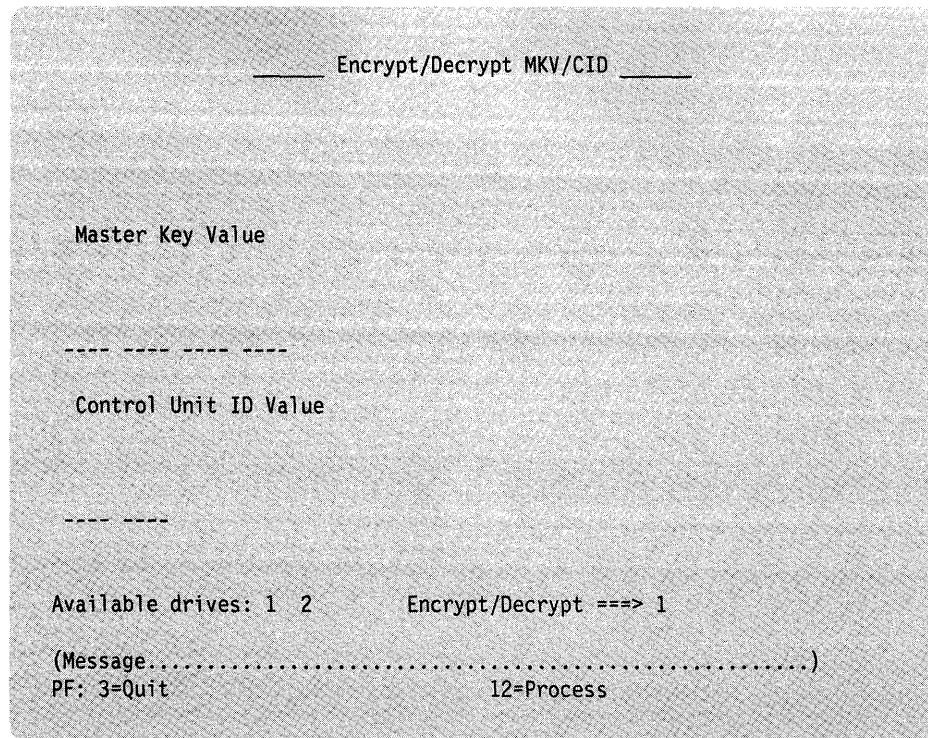

Figure 17-3. Option 1—Enter Master Key Value. From this panel, you can enter a master key value. The master key value is a code that activates the Encrypt/Decrypt Adapter.

Step 3. Fill In the Panel

3-1: Type in the master key value and the control unit ID that have been designated for your organization. This information will not be displayed. Do not leave blanks or spaces between characters.

If you make a typing error, you can retype the information. Use the tab or cursor movement keys to reposition the cursor.

3-2: Press PF12. An asterisk will highlight any field that is invalid, and a message will appear on the message line if any errors are detected. (See *3174 Status Codes*, GA27-3832, for a response to a message, if necessary.)

3-3: If no errors are detected, the Verification Pattern panel appears on the screen. See Figure 17-4.

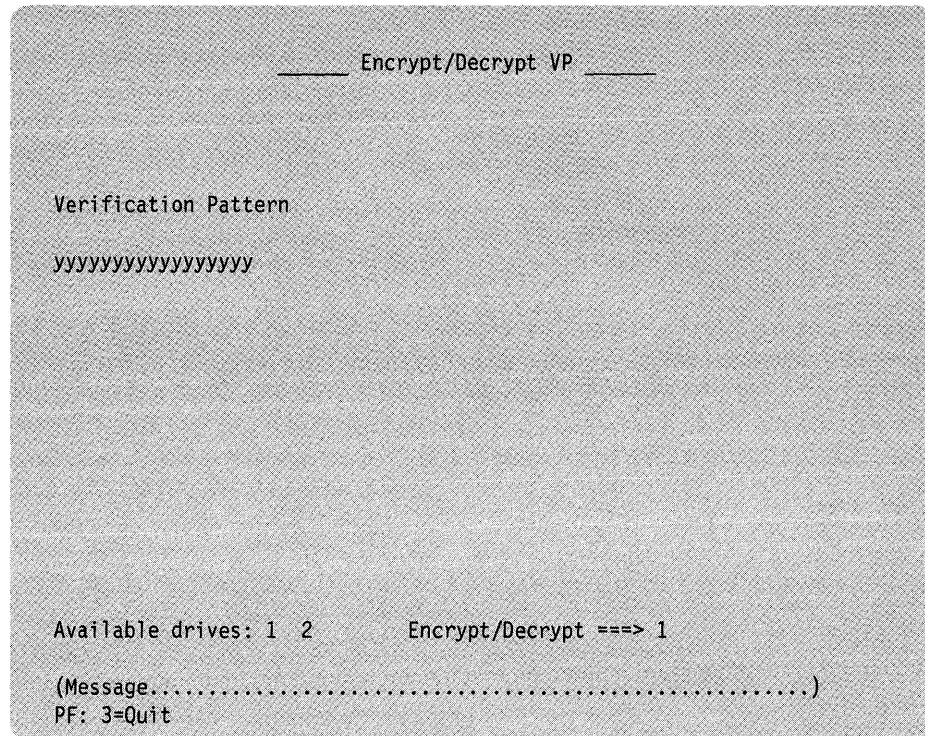

Figure 17-4. Verification Pattern. The “y’s” represent the unique verification pattern.

3-4: To check the status of the master key value (option 2), record this pattern. Periodically, you can check the status of the master key value by comparing the VP on the display with the VP you recorded.

3-5: Turn the security keylock counterclockwise to the horizontal position, and remove the security key from the lock.

What's Next?

From this panel you can:

- Press PF3 to return to the Encrypt/Decrypt Utility panel and select another option.
- Press PF3 again to return to the Master Menu and select another customizing procedure. Remove the Encrypt/Decrypt diskette from the 3174. Identify the diskette by writing a unique designation on its label.

See the “3174 Quick-Reference Guide for Customizing” to locate the information for the procedure you have chosen or to determine the next procedure to perform.

- Exit customizing. To put the 3174 online, IML with the Control diskette that you use for normal operations.

Option 2: Display the Verification Pattern

You need an MKV residing in the adapter.

With this option, you can check the status of the MKV by displaying the verification pattern.

Step 1. Select “Option 2” from the Encrypt/Decrypt Menu

The Encrypt/Decrypt Utility panel is displayed on the screen. (See Figure 17-2 on page 17-6.)

1-1: Type 2 after Select == =>



1-2: Press ENTER. The Encrypt/Decrypt VP panel (Figure 17-5) is displayed on your screen.

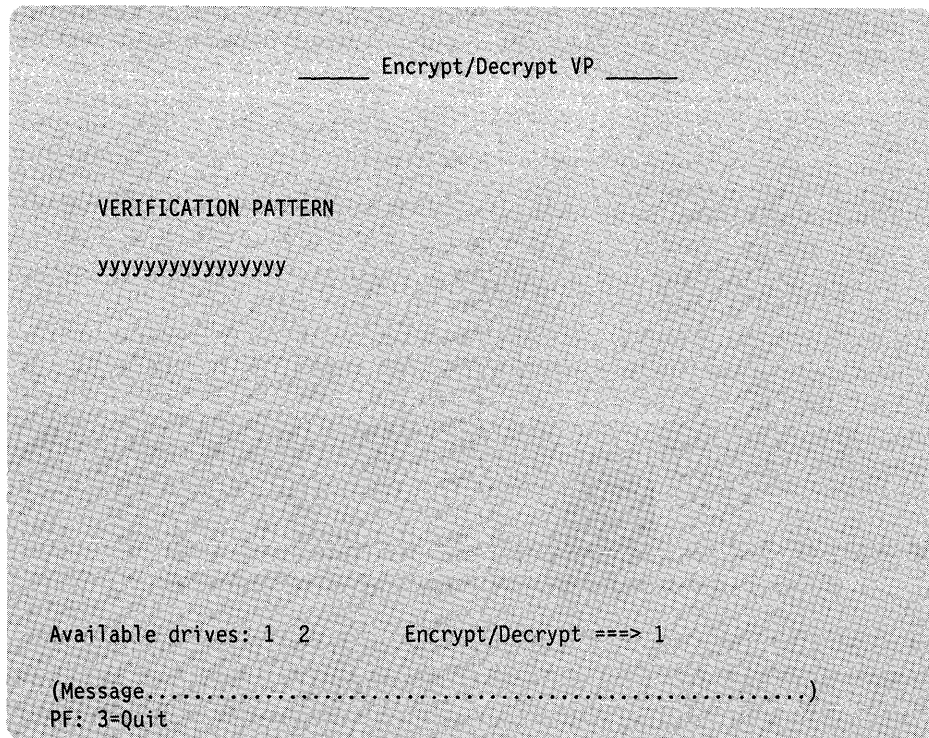

Figure 17-5. Option 2 — Display Verification Pattern

Initializing Encrypt/Decrypt

This option displays the verification pattern on the display screen for the Encrypt/Decrypt diskette that is currently inserted in the control unit's diskette drive. If the displayed pattern matches the verification pattern that was previously recorded, you know that the master key value has *not* been changed. If the displayed pattern does *not* match the verification pattern that was recorded, you know that either:

- A different Encrypt/Decrypt diskette was used to enter the MKV that is currently residing in the adapter of this control unit, or
- The MKV has been changed.

If another diskette could have been used to enter the MKV, insert it and retry Option 2. Otherwise, see "Option 3: Verify the Master Key Value" on page 17-13.

What's Next?

From this panel you can:

- Press PF3 to return to the Encrypt/Decrypt Utility panel.
- Press PF3 again to return to the Master Menu and select another customizing procedure. Remove the Encrypt/Decrypt diskette from the 3174. Identify the diskette by writing a unique designation on its label.

See the "3174 Quick-Reference Guide for Customizing" to locate the information for the procedure you have chosen or to determine the next procedure to perform.

- Exit customizing. To put the 3174 online, IML with the Control diskette that you use for normal operations.

Option 3: Verify the Master Key Value

You Need:

A master key value residing in the adapter.

With this option, you can verify whether the verification pattern residing on the Encrypt/Decrypt diskette matches the master key value installed in the feature adapter.

Step 1. Select Option 3 from the Encrypt/Decrypt Utility Panel

The Encrypt/Decrypt Utility panel is displayed on the screen. (See Figure 17-2 on page 17-6.)

1-1: Type 3 after Select = = = >



The Encrypt/Decrypt VP panel (Figure 17-6) is displayed on your screen.

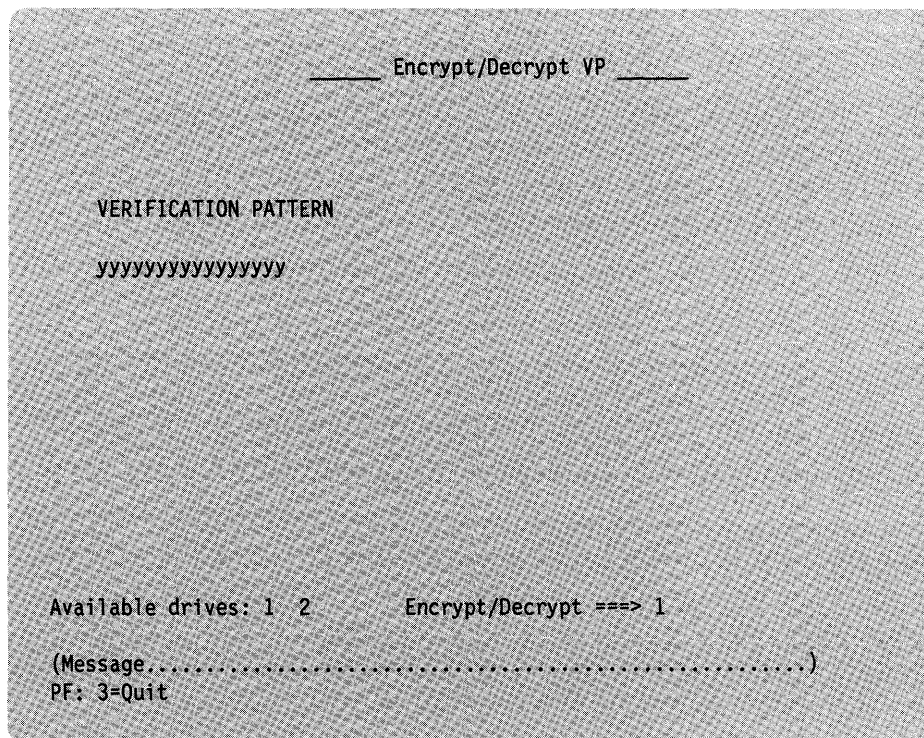

Figure 17-6. Option 3 — Verify Master Key Value. The verification pattern is compared with the master key value in the adapter.

Initializing Encrypt/Decrypt

A message will appear on the message line near the bottom of the screen, indicating whether the verification pattern matches the MKV that resides in the adapter:

- If the verification pattern matches the MKV in the adapter, the MKV has not been changed.
- If the verification pattern does *not* match the MKV in the adapter, the MKV has been changed. Follow your organization's procedure for reporting security violations.

What's Next?

From this panel you can:

- Press PF3 to return to the Encrypt/Decrypt Utility panel and select another option.
- Press PF3 again to return to the Master Menu and select another customizing procedure. Remove the Encrypt/Decrypt diskette from the 3174. Identify the diskette by writing a unique designation on its label.

See the "3174 Quick-Reference Guide for Customizing" to locate the information for the procedure you have chosen or to determine the next procedure to perform.

- Exit customizing. To put the 3174 online, IML with the Control diskette that you use for normal operations.

Option 4: Test the Encrypt/Decrypt Feature

You Need:

The Adapter's security key.

With this option, you can test whether the Encrypt/Decrypt feature is operating properly. Using this option erases the MKV residing in the adapter.

Step 1. Insert the Security Key

1-1: If the security key is not inserted in the 3174 security keylock, obtain the key from the appropriate person in your organization.

Warning: The security keylock must never be put in the fully clockwise (horizontal) position unless the 3174 control unit is turned on.

1-2: Insert the key into the keylock. Make sure the security keylock is in the fully clockwise (horizontal) position; if it is not, turn the key clockwise to the horizontal position.

Step 2. Select Option 4 from the Encrypt/Decrypt Utility Panel

The Encrypt/Decrypt Utility panel is displayed on the screen. (See Figure 17-2 on page 17-6.)

2-1: Type 4 after Select = = = >



The panel shown in Figure 17-7 on page 17-16 will be displayed.

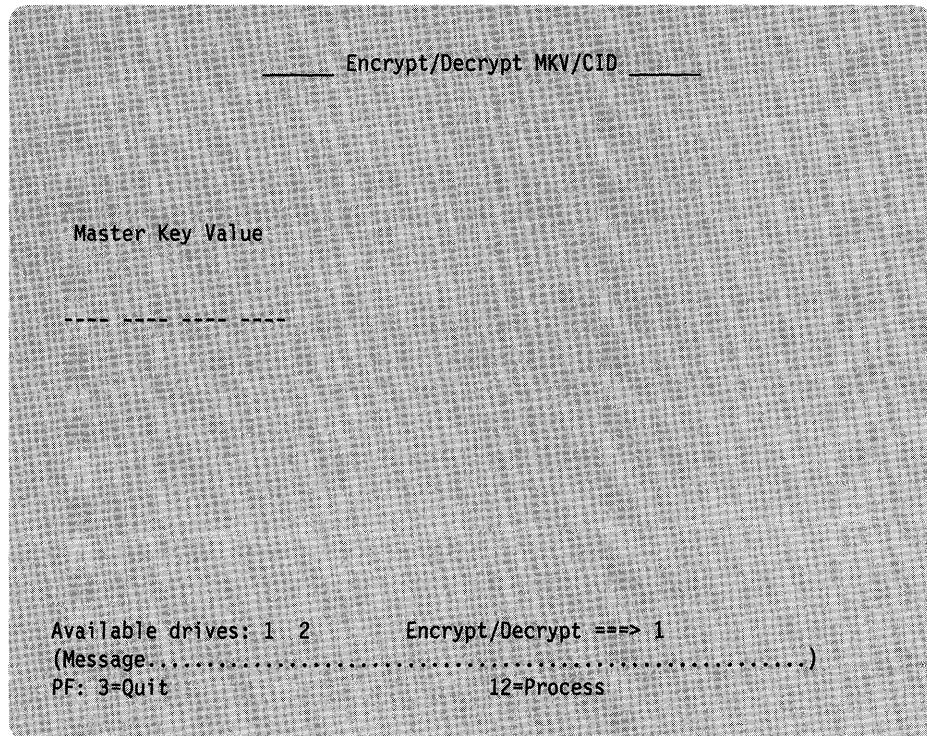

Figure 17-7. Option 4 — Test Encrypt/Decrypt Feature. From this panel, you can test the proper functioning of the Encrypt/Decrypt feature.

2-1: Enter the following sequence of characters into the field under Master Key Value: 0123456789ABCDEF. If you make a typing error, you can retype the information. Use the tab or cursor movement keys to reposition the cursor.

2-2: Press PF12.

If the feature is operating properly, the following verification value is displayed in the Master Key Value field: F188D8504894139E.

If this sequence is not displayed, you should follow your organization's procedure for problem recovery.

What's Next?

From this panel you can:

- Press PF3 to return to the Encrypt/Decrypt Utility panel and select another option.
- Press PF3 again to return to the Master Menu and select another customizing procedure. Remove the Encrypt/Decrypt diskette from the 3174. Identify the diskette by writing a unique designation on its label.

See the "3174 Quick-Reference Guide for Customizing" to locate the information for the procedure you have chosen or to determine the next procedure to perform.

- Exit customizing. To put the 3174 online, IML with the Control diskette that you use for normal operations.

Chapter 18. How to Perform Media Management

Getting Ready to Perform Media Management	18-3
An Overview of Media Management	18-3
Media Management Options	18-4
PF Keys	18-5
IML Source Selection/Deselection Procedure	18-6
Step 1. Select 'Media Management' on the Master Menu	18-6
Step 2. Select Option	18-6
Step 3. Verify Drives	18-7
Step 4. Select/Deselect the IML Source	18-7
What's Next?	18-8
Subdirectory Deletion Procedure	18-9
Step 1. Select "Media Management" on the Master Menu	18-9
Step 2. Select Option	18-9
Step 3. Verify Drives	18-10
Step 4. Delete Subdirectories	18-10
What's Next?	18-11

Getting Ready to Perform Media Management

Before you start, you will need the following:

- At least one fixed disk drive
- A copy of the 3174 Subsystem Control Unit Utility and Control diskettes on a fixed disk. These diskettes must be at or greater than microcode level A4.0 or S4.0.

If you need to perform a copy to the fixed disk, see Chapter 15, "How to Copy Files."

An Overview of Media Management

The Media Management procedure provides you with a tool for managing the data on your fixed disk(s). It allows you to select or deselect subdirectories (each subdirectory holds the contents of a 3174 diskette) that are used for the different IMLs from a fixed disk. For example, the Control subdirectory would be used for an IML, and the Utility subdirectory would be used for an ALT 1 IML.

Media Management eliminates the need for diskette insertion and swapping, thereby allowing you to more efficiently manage your 3174 Subsystem Control Unit. In addition, subdirectories can be deleted from the fixed disk by performing this procedure.

Only certain 3174 diskettes can be copied onto a fixed disk drive and only one of each diskette type can reside on the fixed disk at a time. For example, two Utility diskettes cannot be copied to the fixed disk. The second copy will overwrite the first copy. The diskettes that can be copied to the fixed disk include:

- 3174 Utility (UTL) diskette
- 3174 Control (CTL) diskette
- 3174 Limited Function Utility (LFU) diskette
- 3174 Library (LIB) diskette
- 3174 Down Stream Load (DSL) diskette

Notes:

1. The Utility and Control diskettes must be at or greater than microcode level A4.0 or S4.0.
2. The DSL diskette can contain microcode for up to four of the following: 3290, 3179-G, 3192-G, 3193, and 3174 feature 3020 - AEA.

Warning: When both the Utility and the Limited Function Utility diskettes are copied to the fixed disk, the system will IML from the one most recently copied. For example, if you copy the Limited Function Utility diskette to the fixed disk first and then copy the Utility diskette to the fixed disk, the Utility disk is used for the IML. This can be overridden by performing the procedure under "IML Source Selection/Deselection Procedure" on page 18-6.

Media Management Options

The Media Management procedure provides you with two main options: Select/Deselect IML Source and Delete Subdirectory. These options allow you to indicate which subdirectory or subdirectories you wish to be IMLed or deleted.

What happens next depends on the option you select from the Media Management Menu (Figure 18-1).

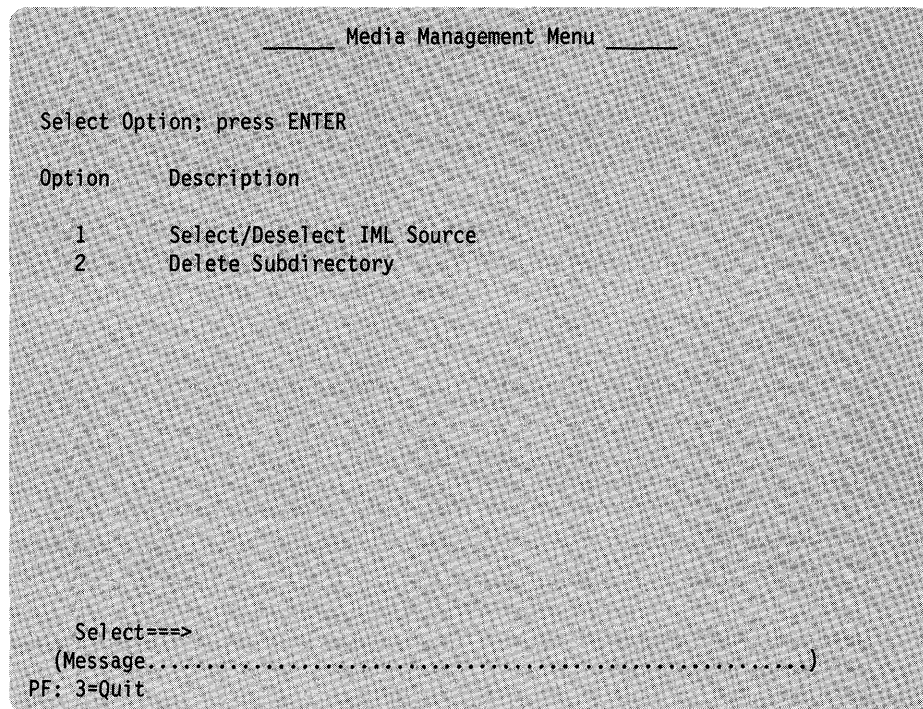

Figure 18-1. Media Management Menu

Selecting option 1, "Select/Deselect IML Source," presents the IML Source Selection panel. (See Figure 18-5 on page 18-7.) Selecting option 2, "Delete Subdirectory," presents the Subdirectory Deletion panel. (See Figure 18-8 on page 18-10.)

PF Keys

You call up a specific function of the customizing program by pressing a PF key. One or both of these PF keys may appear on the panels during the Media Management procedure. A PF key is operational only if it appears on the panel you are using.



Figure 18-2. Media Management PF Keys.

PF3 PF3 (Quit) quits the procedure and erases all responses entered that have not been processed by pressing PF12. When the IML Source Selection or the Subdirectory Deletion panel is on the screen, pressing PF3 returns you to the Media Management Menu panel. Pressing PF3 on the Media Management Menu panel returns you to the Master Menu.

PF12 PF12 (Process) processes the options specified during this procedure. If you are using a Data Entry, Data Entry Key punch, or non-QWERTY keyboard without PF12, use PA2.

Note: Keyboards with PF13 through 24 are mapped into PF1 through 12. For example, PF13 is PF1 and PF15 is PF3.

Now you are ready to perform one of the following Media Management Procedures. If you want to:

Select or Deselect the IML Source, turn to page 18-6 and begin the procedure.

Delete Subdirectories, turn to page 18-9 and begin the procedure.

IML Source Selection/Deselection Procedure

The following sequence of steps should be used to select the IML source.

Step 1. Select 'Media Management' on the Master Menu

1-1: Display the Master Menu. (See Chapter 12, "How to Display the Master Menu," for instructions.)

1-2: Type **8** after Select = = = >

```
Select====> 8
```

1-3: Press ENTER.

Step 2. Select Option

The Media Management Menu appears on your screen (see Figure 18-3).

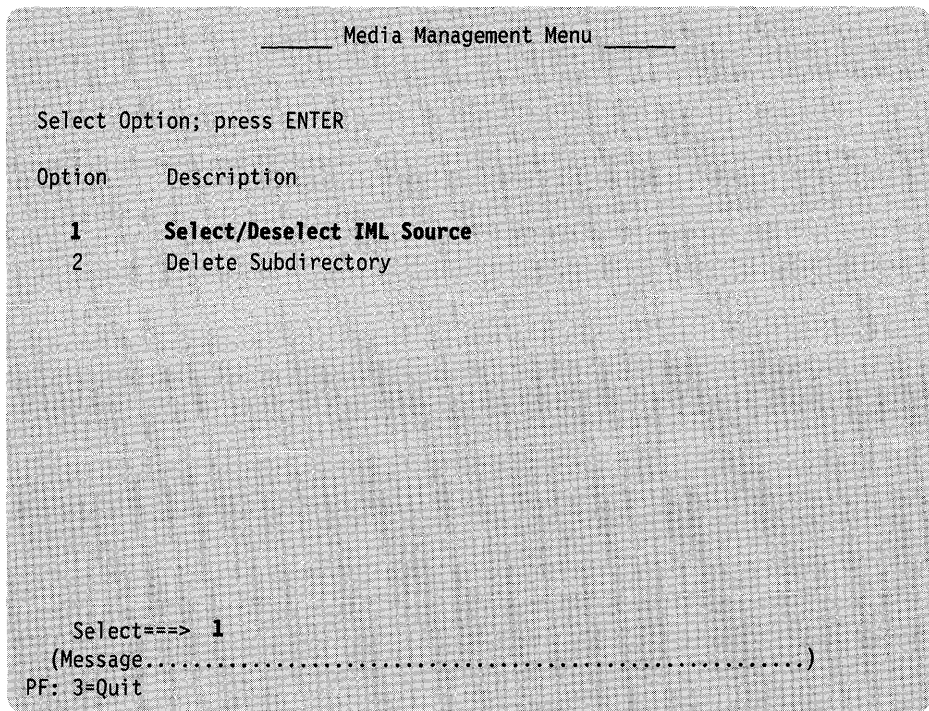

Figure 18-3. Media Management Menu displayed

2-1: Type **1** after Select = = = >

2-2: Press ENTER.

Step 3. Verify Drives

The prompt shown in Figure 18-4 appears on your screen.

Select drive == => is defaulted to the first available fixed disk drive installed. A message prompts you to verify the default drive selection.

Available drives: 3 4 Select Drive ===> 3

Figure 18-4. The Media Management Disk Drive Assignment Panel

3-1: If you do not want to use the default drive selection, type the number of the fixed disk drive that you want to use after **Select drive** == => .

3-2: Press ENTER.

Step 4. Select/Deselect the IML Source

The IML Source Selection panel appears on your screen (see Figure 18-5) along with the selectable subdirectories on the drive you specified.

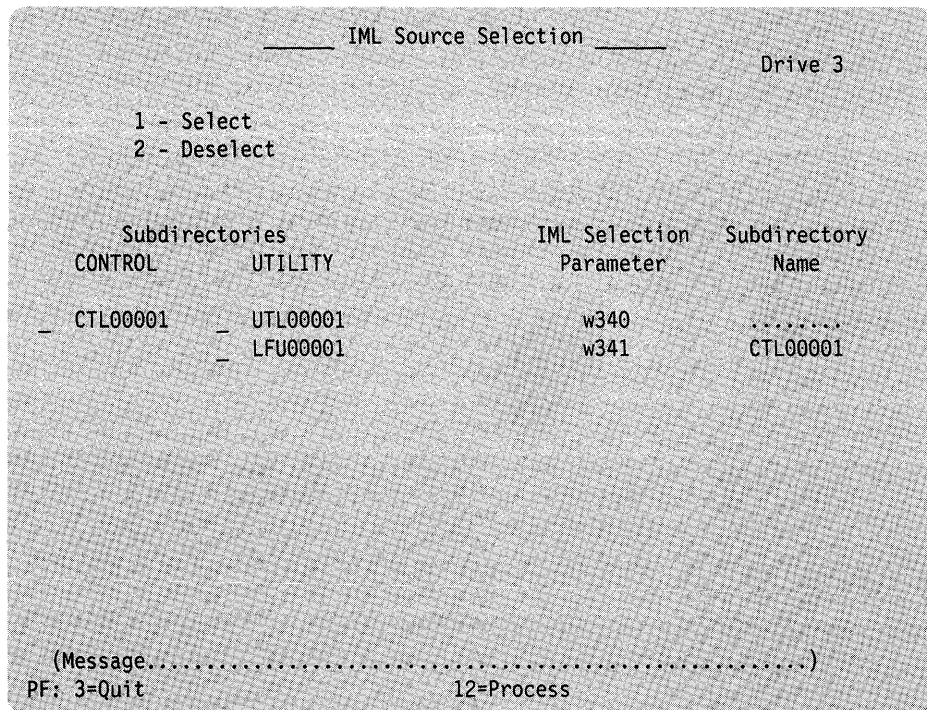

Figure 18-5. IML Source Selection Panel

How to Perform Media Management

4-1: Type a **1** (Select) in the space provided before each subdirectory you want used during an IML.

Note: Only one Utility subdirectory can be selected at a time.

4-2: Type a **2** (Deselect) in the space provided before each subdirectory you do not want used during an IML.

Note: Only one Utility subdirectory can be deselected at a time.

4-3: Press ENTER.

- If the responses are valid, a message indicates that all responses are correct and you will be prompted to press PF12.
- If a response is invalid, the response is highlighted. A four-digit status code and message displayed on the message line explain why the response is invalid. (See *3174 Status Codes, GA27-3832*, for a description of the status codes.)
 1. Correct the highlighted response.
 2. Press ENTER. The status code changes to explain any other invalid responses.
 3. Continue correcting responses until none are highlighted. A message indicates that all responses are correct after the ENTER key is pressed.

4-4: Press PF12 to process.

The responses are saved and the selected subdirectory names appear under the Subdirectory Selection Name section on the right side of your screen. A series of eight periods will appear in the subdirectory name fields not selected for IML.

What's Next?

You Can:

- Change your selections.
- Press PF3 to return to the Media Management Menu and select an option.
- Press PF3 twice to return to the Master Menu. See the "3174 Quick-Reference Guide for Customizing" to locate the information for the procedure you have chosen or to determine the next procedure to perform.

Subdirectory Deletion Procedure

The following sequence of steps should be used to delete unwanted or bad subdirectories from a fixed disk drive.

Step 1. Select “Media Management” on the Master Menu

1-1: Display the Master Menu. (See Chapter 12, “How to Display the Master Menu,” for directions.)

1-2: Type **8** after Select = = = >

```
Select===> 8
```

1-3: Press the ENTER.

Step 2. Select Option

The Media Management Menu appears on your screen (see Figure 18-6).

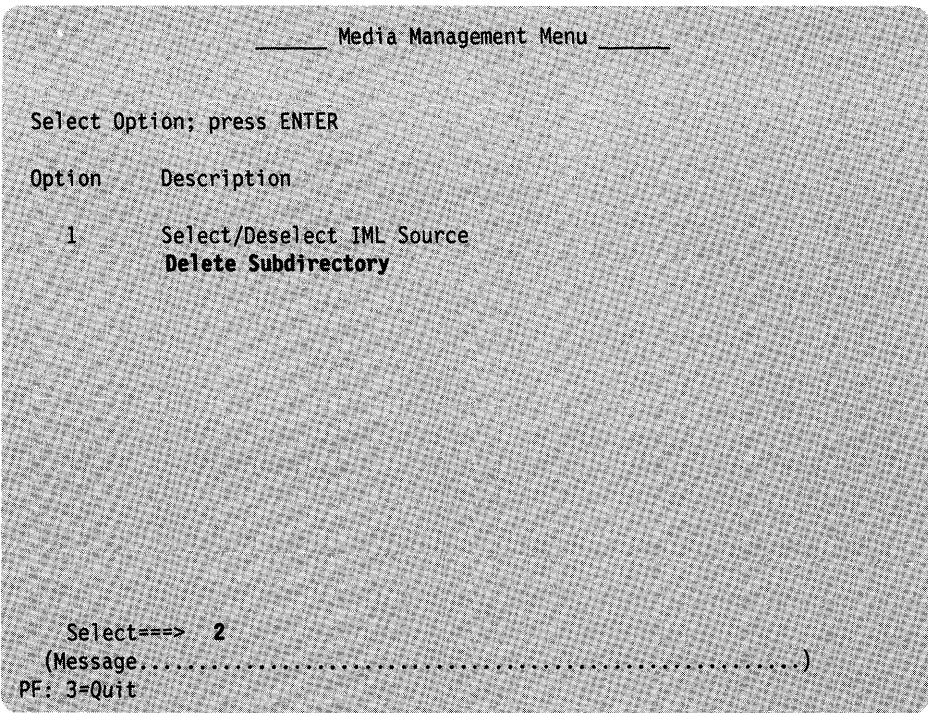

Figure 18-6. Media Management Menu

2-1: Type **2** after Select = = = >

2-2: Press ENTER.

Step 3. Verify Drives

The prompt shown in Figure 18-7 appears on your screen.

Select drive == => is defaulted to the first available fixed disk drive installed. A message prompts you to verify the default drive selection.

```
Available drives: 3 4      Select drive == => 3
```

Figure 18-7. The Media Management Disk Drive Assignment Panel

3-1: If you do not want to use the default drive selection, type the fixed disk drive number that you want to use after **Select drive** == => .

3-2: Press ENTER.

Step 4. Delete Subdirectories

The Subdirectory Deletion panel appears on your screen (see Figure 18-8) listing the subdirectories on the drive you specified.

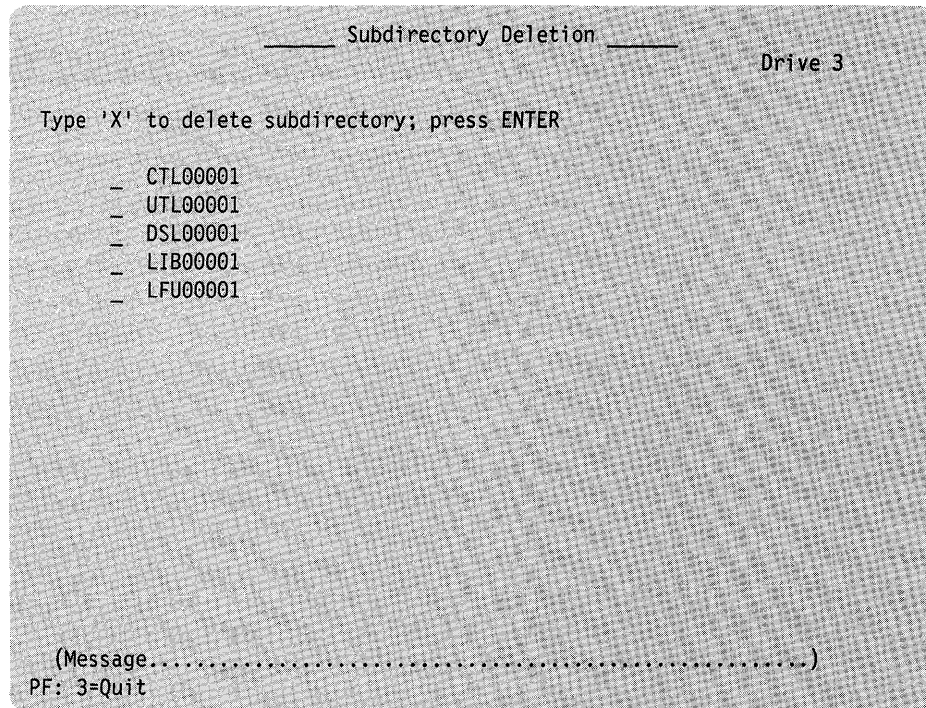

Figure 18-8. Subdirectory Deletion Panel

4-1: Type an **X** in the space provided before each subdirectory name you want deleted from the fixed disk.

4-2: Press ENTER.

A message displaying the number of subdirectories to be deleted and a request for you to press ENTER appear on the message line near the bottom of your screen. Verify that these are the subdirectories you want deleted.

4-3: Press ENTER.

The subdirectories you marked with an **X** are deleted and replaced with a series of eight periods. A message will appear on the message line near the bottom of your screen informing you that the deletion is complete.

What's Next?

You Can:

- Delete more subdirectories.
- Press PF3 to return to the Media Management Menu and select an option.
- Press PF3 twice to return to the Master Menu. See the "3174 Quick-Reference Guide for Customizing" to locate the information for the procedure you have chosen or to determine the next procedure to perform.

Chapter 19. How to Identify Customizing Keyboards

Getting Ready to Identify the Customizing Keyboard	19-3
When Do You Need to Identify the Customizing Keyboard?	19-3
Identify the Customizing Keyboard Procedure	19-4
PF Keys	19-4
Step 1. Select 'Identify Customizing Keyboard' on the Master Menu	19-4
Step 2. Select the Keyboard Type	19-5

Getting Ready to Identify the Customizing Keyboard

Before you start, you need to see Chapter 1, "For First-Time Users" for a list of display stations that can be used as customizing display stations attached to port 26-00 of the 3174 Subsystem Control Unit.

When Do You Need to Identify the Customizing Keyboard?

You need to identify the customizing keyboard when you first customize with a Utility disk and when you recustomize with a Utility disk.

When you first customize with a Utility disk: If the keyboard of the display station being used for customizing is in one of these languages, you must identify it *before* you begin any other customizing procedure:

- Austrian/German
- Belgian
- French, AZERTY
- Italian
- Japanese English
- Japanese Katakana.

The default is a QWERTY keyboard layout, which is available in many languages. On a QWERTY layout, the first six characters on the left side of the top row of alphabetic characters are Q-W-E-R-T-Y. The same naming scheme is also used for other types of layouts, for example, the AZERTY layout.

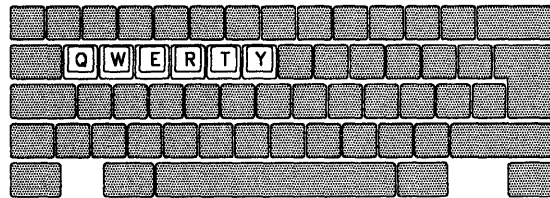

If your keyboard has the default layout, you do not need to select this procedure.

After you complete the Identify Customizing Keyboard procedure, the customizing keyboard you specify will be supported on that Utility disk for all the other customizing procedures.

When you recustomize with a Utility disk: If you want to change keyboards, or if you do not know what keyboard was used when the Utility disk was previously customized, select the Identify Customizing Keyboard procedure. On the Customizing Keyboard panel, the keyboard layout that is currently identified on the Utility disk will be highlighted and the cursor will be next to it. If you want, you can select a different type of keyboard layout.

Now you are ready to identify the keyboard. Turn to page 19-4 to begin the procedure.

Identify the Customizing Keyboard Procedure

The following sequence of steps should be used to identify the customizing keyboard.

PF Keys

You call up a specific function of the customizing program by pressing a PF key.

These two PF keys appear on the panel you use during the Identify Customizing Keyboard procedure:



PF: 3=Quit

12=Done

PF3 PF3 (Quit) erases the response you just entered. It takes you out of the procedure and displays the Master Menu on your screen. Either the default response or the keyboard layout you selected when you previously customized the disk will be in effect.

PF12 Pressed at the end of the procedure, PF12 (Done) saves the response you entered on the panel. Then the Master Menu appears on your screen. If the keyboard you are using does not have a PF12 key, use PA2.

Step 1. Select 'Identify Customizing Keyboard' on the Master Menu

1-1: Display the Master Menu. (See Chapter 12, "How to Display the Master Menu" for directions.)

1-2: Type **K** after Select = = = >



Select ===> K

1-3: Press ENTER on the keyboard.

Step 2. Select the Keyboard Type

The Customize Keyboard panel (Figure 19-1) appears on your screen.

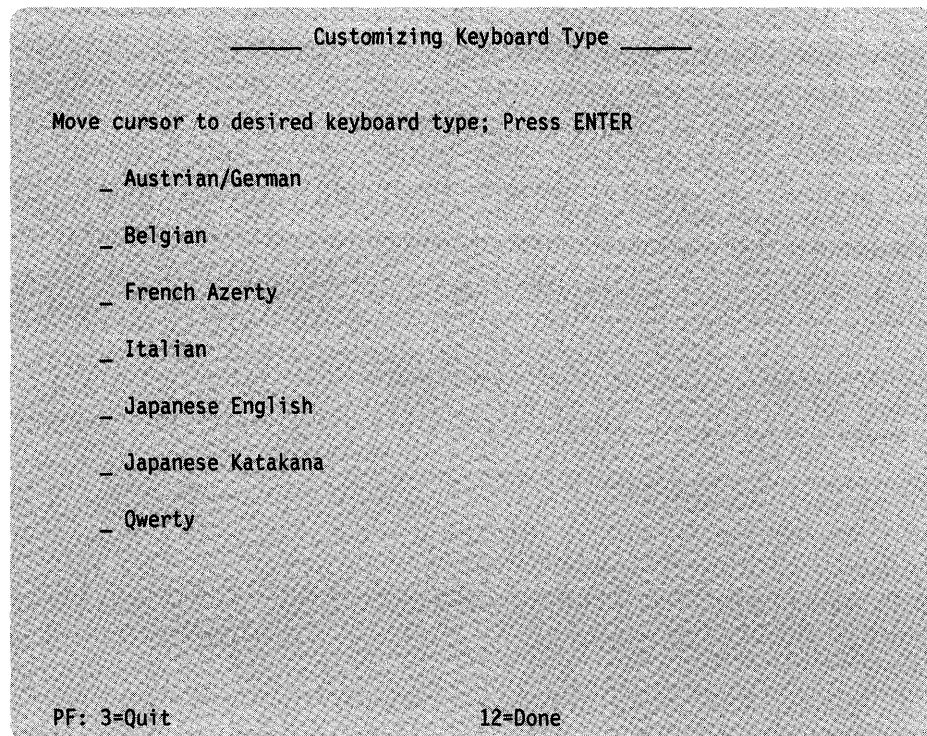

Figure 19-1. Identify Customizing Keyboard Panel

The cursor is in front of the current keyboard choice, which is highlighted. If no other keyboard type has been specified, the cursor is in front of QWERTY, the default selection.

2-1: Position the cursor in front of the selection.

2-2: Press the ENTER key. Your selection is highlighted on the screen.

2-3: Press PF12 to save your input and to return to the Master Menu.

Notes:

1. If your keyboard does not have a PF11 and PF12 key, use PA1 for PF11 and PA2 for PF12.
2. Austrian/German (QWERTZ) Data Entry keyboards use ATTN as PF9 and CURSR SEL as PF10.

Now that the customizing keyboard has been identified, you can select any customizing procedure on the Master Menu. See the "3174 Quick-Reference Guide for Customizing" to locate the information for the procedure you have chosen or to determine the next procedure to perform.

Part 4. Worksheets

Chapter 20. Configuration Worksheets

Chapter 20. Configuration Worksheets

Worksheet 1—Host Attachment	20-3
Worksheet 2—BSC	20-4
Worksheet 3—X.25	20-5
Worksheet 4—SDLC	20-6
Worksheet 5—X.21 Switched	20-7
Worksheet 6—Local (Non-SNA)	20-8
Worksheet 7—Local (SNA)	20-9
Worksheet 8—Token-Ring Network	20-10
Worksheet 9—Token-Ring Gateway	20-11
Worksheet 10—Ring Address Assignment	20-12
Worksheet 11—Ring Transmission Definition	20-13
Worksheet 12—117: Port Assignment	20-14
Worksheet 13—128: RTM	20-15
Worksheet 14—X.25 Options	20-16
Worksheet 15—Printer Authorization Matrix (PAM)	20-17
Worksheet 16—3270 Attachment Diagram	20-18
Worksheet 17—ASCII Attachment Diagram	20-19
Worksheet 18—AEA Configure	20-20
Worksheet 19—AEA Port Set	20-21
Worksheet 20—AEA Port to Port Set Map	20-22
Worksheet 21—AEA Station Set	20-23
Worksheet 22—AEA Default Destination	20-24
Worksheet 23—Multiple Logical Terminals	20-25
Worksheet 24—Common SNA	20-26
Non-Katakana Converged Keyboards	20-27
Katakana Converged Keyboards	20-28
Enhanced Keyboard (U.S.)	20-29
Enhanced Keyboard (World Trade)	20-30
Enhanced Keyboard (Katakana)	20-31
Configuration Questions Summary	20-32

Permission to Copy

You are hereby authorized to copy the worksheets in this chapter. Make as many copies of these worksheets as you need to plan for customizing. Save the blank original for later planning.

Worksheet 2—BSC

Chapter 3 of the 3174 Customizing Guide contains the planning information needed.

BSC

104 - <input type="checkbox"/> <input type="checkbox"/> X X	108 - <input type="checkbox"/> <input type="checkbox"/> <input type="checkbox"/> <input type="checkbox"/> <input type="checkbox"/> <input type="checkbox"/> <input type="checkbox"/> <input type="checkbox"/> <input type="checkbox"/> <input type="checkbox"/> <input type="checkbox"/> <input type="checkbox"/>	110 - <input type="checkbox"/> 0	116 - <input type="checkbox"/> 0
121 - <input type="checkbox"/> <input type="checkbox"/> 0 1	123 - <input type="checkbox"/> 0	125 - <input type="checkbox"/> <input type="checkbox"/> <input type="checkbox"/> <input type="checkbox"/> <input type="checkbox"/> <input type="checkbox"/> <input type="checkbox"/> <input type="checkbox"/> <input type="checkbox"/> <input type="checkbox"/> <input type="checkbox"/> <input type="checkbox"/>	127 - <input type="checkbox"/> <input type="checkbox"/> 0 0
132 - <input type="checkbox"/> <input type="checkbox"/> <input type="checkbox"/> <input type="checkbox"/> 0 0 0 0	136 - <input type="checkbox"/> <input type="checkbox"/> <input type="checkbox"/> <input type="checkbox"/> 0 0 0 0	137 - <input type="checkbox"/> <input type="checkbox"/> <input type="checkbox"/> <input type="checkbox"/> 0 0 0 0	138 - <input type="checkbox"/> 0
141 - <input type="checkbox"/> A	165 - <input type="checkbox"/> 1	166 - <input type="checkbox"/> A	168 - <input type="checkbox"/> 0
173 - <input type="checkbox"/> <input type="checkbox"/> <input type="checkbox"/> <input type="checkbox"/> <input type="checkbox"/> <input type="checkbox"/> <input type="checkbox"/> <input type="checkbox"/> <input type="checkbox"/> <input type="checkbox"/> <input type="checkbox"/> <input type="checkbox"/>	175 - <input type="checkbox"/> <input type="checkbox"/> <input type="checkbox"/> <input type="checkbox"/> <input type="checkbox"/> <input type="checkbox"/> <input type="checkbox"/> <input type="checkbox"/>	176 - <input type="checkbox"/> 0	178 - <input type="checkbox"/> 0
317 - <input type="checkbox"/> 0	318 - <input type="checkbox"/> 0	340 - <input type="checkbox"/> 0	

- 104: Control Unit Address
- 108: Unique Machine Identifier
- 110: Multiple Logical Terminals (MLT) Configuration Level
- 116: Individual Port Assignment
- 121: Keyboard Language and Character Set I/O Interface Code
- 123: Country Extended Code Page Support
- 125: Miscellaneous Feature Options
- 127: Response Time Monitor (RTM) Definition
- 132: Alternate Keyboard Selection
- 136: Modifiable Keyboards: Standard Layouts
- 137: Modifiable Keyboard: Modified Layouts
- 138: Modifiable Keypad: Standard Layouts
- 141: Magnetic Character Set
- 165: Compressed Program Symbols
- 166: Attribute Select Keyboard
- 168: Additional Extension-Mode Key Definition
- 173: Distributed Function Terminal (DFT) Options
- 175: Distributed Function Terminal (DFT) Password
- 176: BSC Enhanced Communication Option: Distributed Function Terminals
- 178: 7232 Dual Control Unit Terminal Multiplexer Switching
- 317: Telecommunication Facilities (BSC and SDLC)
- 318: Full- or Half-Speed Transmission (BSC and SDLC)
- 340: RTS Control Options (BSC and SDLC)

Worksheet 3—X.25

Chapter 3 of the 3174 Customizing Guide contains the planning information needed.

X.25

104 -
X X

108 -
0 0 0 0 0 0 0 0

110 -
0

116 -
0

121 -
0 1

123 -
0

125 -
0 0 0 0 0 0 0 0 0 0

127 -
0 0

132 -
0 0 0 0

136 -
0 0 0 0

137 -
0 0 0 0

138 -
0

141 -
A

165 -
1

166 -
A

168 -
0

173 -
0 0 0 0 0 0 0 0 0

175 -
0 0 0 0 0 0 0

178 -
0

213 -
1

215 -
0 0 0 0 0 0

220 -
0

365 -
0

- 104: Control Unit Address
- 108: Unique Machine Identifier
- 110: Multiple Logical Terminals (MLT) Configuration Level
- 116: Individual Port Assignment
- 121: Keyboard Language and Character Set I/O Interface Code
- 123: Country Extended Code Page Support
- 125: Miscellaneous Feature Options
- 127: Response Time Monitor (RTM) Definition
- 132: Alternate Keyboard Selection
- 136: Modifiable Keyboards: Standard Layouts
- 137: Modifiable Keyboard: Modified Layouts
- 138: Modifiable Keypad: Standard Layouts
- 141: Magnetic Character Set
- 165: Compressed Program Symbols
- 166: Attribute Select Keyboard
- 168: Additional Extension-Mode Key Definition
- 173: Distributed Function Terminal (DFT) Options
- 175: Distributed Function Terminal (DFT) Password
- 178: 7232 Dual Control Unit Terminal Multiplexer Switching
- 213: Between Bracket Printer Sharing (SDLC, X.25, X.21 Switched, Local SNA, Token-Ring Network)
- 215: Physical Unit Identification (SDLC, X.25, X.21 Switched, Local SNA, Token-Ring Network)
- 220: Alert Function (SDLC, X.25, X.21 Switched, Local SNA, Token-Ring Network)
- 365: X.21 Switched Host DTE Connection (Models 2R, 52R, and 82R)

Worksheet 4—SDLC

Chapter 3 of the 3174 Customizing Guide contains the planning information needed.

SDLC			
104 - <input type="checkbox"/> <input type="checkbox"/> X X	105 - <input type="checkbox"/> <input type="checkbox"/> 0 0	108 - <input type="checkbox"/> <input type="checkbox"/> <input type="checkbox"/> <input type="checkbox"/> <input type="checkbox"/> <input type="checkbox"/> <input type="checkbox"/> <input type="checkbox"/> 0 0 0 0 0 0 0 0	110 - <input type="checkbox"/> 116 - <input type="checkbox"/> 0 0
121 - <input type="checkbox"/> <input type="checkbox"/> 0 1	123 - <input type="checkbox"/> 0	125 - <input type="checkbox"/> <input type="checkbox"/> <input type="checkbox"/> <input type="checkbox"/> <input type="checkbox"/> <input type="checkbox"/> <input type="checkbox"/> <input type="checkbox"/> <input type="checkbox"/> 0 0 0 0 0 0 0 0 0	127 - <input type="checkbox"/> <input type="checkbox"/> 0 0
132 - <input type="checkbox"/> <input type="checkbox"/> <input type="checkbox"/> <input type="checkbox"/> 0 0 0 0	136 - <input type="checkbox"/> <input type="checkbox"/> <input type="checkbox"/> <input type="checkbox"/> 0 0 0 0	137 - <input type="checkbox"/> <input type="checkbox"/> <input type="checkbox"/> <input type="checkbox"/> 0 0 0 0	138 - <input type="checkbox"/> 0
141 - <input type="checkbox"/> A	165 - <input type="checkbox"/> 1	166 - <input type="checkbox"/> A	168 - <input type="checkbox"/> 0
173 - <input type="checkbox"/> <input type="checkbox"/> <input type="checkbox"/> <input type="checkbox"/> <input type="checkbox"/> <input type="checkbox"/> <input type="checkbox"/> <input type="checkbox"/> <input type="checkbox"/> <input type="checkbox"/> 0 0 0 0 0 0 0 0 0	175 - <input type="checkbox"/> <input type="checkbox"/> <input type="checkbox"/> <input type="checkbox"/> <input type="checkbox"/> <input type="checkbox"/> <input type="checkbox"/> <input type="checkbox"/> 0 0 0 0 0 0 0 0	178 - <input type="checkbox"/> 0	
213 - <input type="checkbox"/> 1	215 - <input type="checkbox"/> <input type="checkbox"/> <input type="checkbox"/> <input type="checkbox"/> <input type="checkbox"/> <input type="checkbox"/> 0 0 0 0 0 0	220 - <input type="checkbox"/> 0	
310 - <input type="checkbox"/> 0	313 - <input type="checkbox"/> 0	317 - <input type="checkbox"/> 0	318 - <input type="checkbox"/> 340 - <input type="checkbox"/> 0 0
365 - <input type="checkbox"/> 0	370 - <input type="checkbox"/> 0		

- 104: Control Unit Address
- 105: Upper Limit Address
- 108: Unique Machine Identifier
- 110: Multiple Logical Terminals (MLT) Configuration Level
- 116: Individual Port Assignment
- 121: Keyboard Language and Character Set I/O Interface Code
- 123: Country Extended Code Page Support
- 125: Miscellaneous Feature Options
- 127: Response Time Monitor (RTM) Definition
- 132: Alternate Keyboard Selection
- 136: Modifiable Keyboards: Standard Layouts
- 137: Modifiable Keyboard: Modified Layouts
- 138: Modifiable Keypad: Standard Layouts
- 141: Magnetic Character Set
- 165: Compressed Program Symbols
- 166: Attribute Select Keyboard
- 168: Additional Extension-Mode Key Definition
- 173: Distributed Function Terminal (DFT) Options
- 175: Distributed Function Terminal (DFT) Password
- 178: 7232 Dual Control Unit Terminal Multiplexer Switching
- 213: Between Bracket Printer Sharing (SDLC, X.25, X.21 Switched, Local SNA, Token-Ring Network)
- 215: Physical Unit Identification (SDLC, X.25, X.21 Switched, Local SNA, Token-Ring Network)
- 220: Alert Function (SDLC, X.25, X.21 Switched, Local SNA, Token-Ring Network)
- 310: Connect-Data-Set-to-Line Operation
- 313: NRZ or NRZI Encoding
- 317: Telecommunication Facilities (BSC and SDLC)
- 318: Full- or Half Speed Transmission (BSC and SDLC)
- 340: RTS Control Options (BSC and SDLC)
- 365: X.21 Switched Host DTE Connection (Models 2R, 52R, and 82R)
- 370: Maximum Inbound I-Frame Size

Worksheet 5—X.21 Switched

Chapter 3 of the 3174 Customizing Guide contains the planning information needed.

X.21 Switched			
104 - <input type="checkbox"/> <input type="checkbox"/> X X	108 - <input type="checkbox"/> <input type="checkbox"/> <input type="checkbox"/> <input type="checkbox"/> <input type="checkbox"/> <input type="checkbox"/> <input type="checkbox"/> <input type="checkbox"/> 0 0 0 0 0 0 0	110 - <input type="checkbox"/> 0	116 - <input type="checkbox"/> 0
121 - <input type="checkbox"/> <input type="checkbox"/> 0 1	123 - <input type="checkbox"/> 0	125 - <input type="checkbox"/> <input type="checkbox"/> <input type="checkbox"/> <input type="checkbox"/> <input type="checkbox"/> <input type="checkbox"/> <input type="checkbox"/> <input type="checkbox"/> <input type="checkbox"/> <input type="checkbox"/> 0 0 0 0 0 0 0 0 0	127 - <input type="checkbox"/> <input type="checkbox"/> 0 0
132 - <input type="checkbox"/> <input type="checkbox"/> <input type="checkbox"/> <input type="checkbox"/> 0 0 0 0	136 - <input type="checkbox"/> <input type="checkbox"/> <input type="checkbox"/> <input type="checkbox"/> 0 0 0 0	137 - <input type="checkbox"/> <input type="checkbox"/> <input type="checkbox"/> <input type="checkbox"/> 0 0 0 0	138 - <input type="checkbox"/> 0
141 - <input type="checkbox"/> A	165 - <input type="checkbox"/> 1	166 - <input type="checkbox"/> A	168 - <input type="checkbox"/> 0
173 - <input type="checkbox"/> <input type="checkbox"/> <input type="checkbox"/> <input type="checkbox"/> <input type="checkbox"/> <input type="checkbox"/> <input type="checkbox"/> <input type="checkbox"/> <input type="checkbox"/> 0 0 0 0 0 0 0 0	175 - <input type="checkbox"/> <input type="checkbox"/> <input type="checkbox"/> <input type="checkbox"/> <input type="checkbox"/> <input type="checkbox"/> 0 0 0 0 0 0	178 - <input type="checkbox"/> 0	
213 - <input type="checkbox"/> 1	215 - <input type="checkbox"/> <input type="checkbox"/> <input type="checkbox"/> <input type="checkbox"/> <input type="checkbox"/> 0 0 0 0 0	220 - <input type="checkbox"/> 0	
360 - <input type="checkbox"/> <input type="checkbox"/> 0	361 - <input type="checkbox"/> <input type="checkbox"/> 0 0	362 - <input type="checkbox"/> <input type="checkbox"/> <input type="checkbox"/> <input type="checkbox"/> <input type="checkbox"/> <input type="checkbox"/> <input type="checkbox"/> <input type="checkbox"/> <input type="checkbox"/> 0 0 0 0 0 0 0 0	
367 - <input type="checkbox"/> 0	368 - <input type="checkbox"/> <input type="checkbox"/> <input type="checkbox"/> <input type="checkbox"/> <input type="checkbox"/> <input type="checkbox"/> <input type="checkbox"/> <input type="checkbox"/> <input type="checkbox"/> <input type="checkbox"/> <input type="checkbox"/> <input type="checkbox"/> 0 0 0 0 0 0 0 0 0 0 0 0	370 - <input type="checkbox"/> 0	

- 104: Control Unit Address
- 108: Unique Machine Identifier
- 110: Multiple Logical Terminals (MLT) Configuration Level
- 116: Individual Port Assignment
- 121: Keyboard Language and Character Set I/O Interface Code
- 123: Country Extended Code Page Support
- 125: Miscellaneous Feature Options
- 127: Response Time Monitor (RTM) Definition
- 132: Alternate Keyboard Selection
- 136: Modifiable Keyboards: Standard Layouts
- 137: Modifiable Keyboard: Modified Layouts
- 138: Modifiable Keypad: Standard Layouts
- 141: Magnetic Character Set
- 165: Compressed Program Symbols
- 166: Attribute Select Keyboard
- 168: Additional Extension-Mode Key Definition
- 173: Distributed Function Terminal (DFT) Options
- 175: Distributed Function Terminal (DFT) Password
- 178: 7232 Dual Control Unit Terminal Multiplexer Switching
- 213: Between Bracket Printer Sharing (SDLC, X.25, X.21 Switched, Local SNA, Token-Ring Network)
- 215: Physical Unit Identification (SDLC, X.25, X.21 Switched, Local SNA, Token-Ring Network)
- 220: Alert Function (SDLC, X.25, X.21 Switched, Local SNA, Token-Ring Network)
- 360: X.21 Switched Retry
- 361: X.21 Switched Retry Timing
- 362: X.21 Switched Options
- 367: X.21 Switched Short-Hold Mode
- 368: X.21 Switched Short-Hold Mode Dial Number
- 370: Maximum Inbound I-Frame Size

Worksheet 6—Local (Non-SNA)

Chapter 3 of the 3174 Customizing Guide contains the planning information needed.

Local (Non-SNA)

104 - <input type="checkbox"/> <input type="checkbox"/> X X	105 - <input type="checkbox"/> <input type="checkbox"/> X X	108 - <input type="checkbox"/> <input type="checkbox"/> <input type="checkbox"/> <input type="checkbox"/> <input type="checkbox"/> <input type="checkbox"/> <input type="checkbox"/> <input type="checkbox"/> 0 0 0 0 0 0 0	110 - <input type="checkbox"/> 0	116 - <input type="checkbox"/> 0
121 - <input type="checkbox"/> <input type="checkbox"/> 0 1	123 - <input type="checkbox"/> 0	125 - <input type="checkbox"/> <input type="checkbox"/> <input type="checkbox"/> <input type="checkbox"/> <input type="checkbox"/> <input type="checkbox"/> <input type="checkbox"/> <input type="checkbox"/> <input type="checkbox"/> <input type="checkbox"/> 0 0 0 0 0 0 0 0 0	127 - <input type="checkbox"/> <input type="checkbox"/> 0 0	
132 - <input type="checkbox"/> <input type="checkbox"/> <input type="checkbox"/> <input type="checkbox"/> 0 0 0 0	136 - <input type="checkbox"/> <input type="checkbox"/> <input type="checkbox"/> <input type="checkbox"/> 0 0 0 0	137 - <input type="checkbox"/> <input type="checkbox"/> <input type="checkbox"/> <input type="checkbox"/> 0 0 0 0	138 - <input type="checkbox"/> 0	
141 - <input type="checkbox"/> A	165 - <input type="checkbox"/> 0	166 - <input type="checkbox"/> A	168 - <input type="checkbox"/> 0	
173 - <input type="checkbox"/> <input type="checkbox"/> <input type="checkbox"/> <input type="checkbox"/> <input type="checkbox"/> <input type="checkbox"/> <input type="checkbox"/> <input type="checkbox"/> <input type="checkbox"/> <input type="checkbox"/> 0 0 0 0 0 0 0 0 0	175 - <input type="checkbox"/> <input type="checkbox"/> <input type="checkbox"/> <input type="checkbox"/> <input type="checkbox"/> <input type="checkbox"/> <input type="checkbox"/> <input type="checkbox"/> 0 0 0 0 0 0 0 0	178 - <input type="checkbox"/> 0		
222 - <input type="checkbox"/> 0	224 - <input type="checkbox"/> 2	225 - <input type="checkbox"/> 4		

- 104: Control Unit Address
- 105: Upper Limit Address (Non-SNA or the Token-Ring Network 3270 Gateway Feature)
- 108: Unique Machine Identifier
- 110: Multiple Logical Terminals (MLT) Configuration Level
- 116: Individual Port Assignment
- 121: Keyboard Language and Character Set I/O Interface Code
- 123: Country Extended Code Page Support
- 125: Miscellaneous Feature Options
- 127: Response Time Monitor (RTM) Definition
- 132: Alternate Keyboard Selection
- 136: Modifiable Keyboards: Standard Layouts
- 137: Modifiable Keyboard: Modified Layouts
- 138: Modifiable Keypad: Standard Layouts
- 141: Magnetic Character Set
- 165: Compressed Program Symbols
- 166: Attribute Select Keyboard
- 168: Additional Extension-Mode Key Definition
- 173: Distributed Function Terminal (DFT) Options
- 175: Distributed Function Terminal (DFT) Password
- 178: 7232 Dual Control Unit Terminal Multiplexer Switching
- 222: Support of Command Retry
- 224: Mode of Data Transfer
- 225: Channel Burst Size

Worksheet 7—Local (SNA)

Chapter 3 of the *3174 Customizing Guide* contains the planning information needed.

Local (SNA)

104 - <input type="checkbox"/> <input type="checkbox"/> X X	105 - <input type="checkbox"/> <input type="checkbox"/> 0 0	108 - <input type="checkbox"/> <input type="checkbox"/> <input type="checkbox"/> <input type="checkbox"/> <input type="checkbox"/> <input type="checkbox"/> <input type="checkbox"/> <input type="checkbox"/> 0 0 0 0 0 0 0 0	110 - <input type="checkbox"/> 0	116 - <input type="checkbox"/> 0
121 - <input type="checkbox"/> <input type="checkbox"/> 0 1	123 - <input type="checkbox"/> 0	125 - <input type="checkbox"/> <input type="checkbox"/> <input type="checkbox"/> <input type="checkbox"/> <input type="checkbox"/> <input type="checkbox"/> <input type="checkbox"/> <input type="checkbox"/> <input type="checkbox"/> 0 0 0 0 0 0 0 0 0	127 - <input type="checkbox"/> <input type="checkbox"/> 0 0	
132 - <input type="checkbox"/> <input type="checkbox"/> <input type="checkbox"/> <input type="checkbox"/> 0 0 0 0	136 - <input type="checkbox"/> <input type="checkbox"/> <input type="checkbox"/> <input type="checkbox"/> 0 0 0 0	137 - <input type="checkbox"/> <input type="checkbox"/> <input type="checkbox"/> <input type="checkbox"/> 0 0 0 0	138 - <input type="checkbox"/> 0	
141 - <input type="checkbox"/> A	165 - <input type="checkbox"/> 0	166 - <input type="checkbox"/> A	168 - <input type="checkbox"/> 0	
173 - <input type="checkbox"/> <input type="checkbox"/> <input type="checkbox"/> <input type="checkbox"/> <input type="checkbox"/> <input type="checkbox"/> <input type="checkbox"/> <input type="checkbox"/> <input type="checkbox"/> 0 0 0 0 0 0 0 0 0	175 - <input type="checkbox"/> <input type="checkbox"/> <input type="checkbox"/> <input type="checkbox"/> <input type="checkbox"/> <input type="checkbox"/> <input type="checkbox"/> 0 0 0 0 0 0 0	178 - <input type="checkbox"/> 0		
213 - <input type="checkbox"/> 1	215 - <input type="checkbox"/> <input type="checkbox"/> <input type="checkbox"/> <input type="checkbox"/> <input type="checkbox"/> <input type="checkbox"/> 0 0 0 0 0 0	220 - <input type="checkbox"/> 0		
222 - <input type="checkbox"/> 0	223 - <input type="checkbox"/> <input type="checkbox"/> 1 0	224 - <input type="checkbox"/> 2	225 - <input type="checkbox"/> 4	

- 104: Control Unit Address
- 105: Upper Limit Address
- 108: Unique Machine Identifier
- 110: Multiple Logical Terminals (MLT) Configuration Level
- 116: Individual Port Assignment
- 121: Keyboard Language and Character Set I/O Interface Code
- 123: Country Extended Code Page Support
- 125: Miscellaneous Feature Options
- 127: Response Time Monitor (RTM) Definition
- 132: Alternate Keyboard Selection
- 136: Modifiable Keyboards: Standard Layouts
- 137: Modifiable Keyboard: Modified Layouts
- 138: Modifiable Keypad: Standard Layouts
- 141: Magnetic Character Set
- 165: Compressed Program Symbols
- 166: Attribute Select Keyboard
- 168: Additional Extension-Mode Key Definition
- 173: Distributed Function Terminal (DFT) Options
- 175: Distributed Function Terminal (DFT) Password
- 178: 7232 Dual Control Unit Terminal Multiplexer Switching
- 213: Between Bracket Printer Sharing (SDLC, X.25, X.21 Switched, Local SNA, Token-Ring Network)
- 215: Physical Unit Identification (SDLC, X.25, X.21 Switched, Local SNA, Token-Ring Network)
- 220: Alert Function (SDLC, X.25, X.21 Switched, Local SNA, Token-Ring Network)
- 222: Support of Command Retry
- 223: Attention Delay Value
- 224: Mode of Data Transfer
- 225: Channel Burst Size

Worksheet 8—Token-Ring Network

Chapter 3 of the 3174 Customizing Guide contains the planning information needed.

Token-Ring Network

106 - <input type="checkbox"/> <input type="checkbox"/> <input type="checkbox"/> <input type="checkbox"/> <input type="checkbox"/> <input type="checkbox"/> <input type="checkbox"/> <input type="checkbox"/> <input type="checkbox"/> <input type="checkbox"/> <input type="checkbox"/> <input type="checkbox"/> <input type="checkbox"/> <input type="checkbox"/> <input type="checkbox"/> <input type="checkbox"/>	107 - <input type="checkbox"/> <input type="checkbox"/> <input type="checkbox"/> <input type="checkbox"/> <input type="checkbox"/> <input type="checkbox"/> <input type="checkbox"/> <input type="checkbox"/> <input type="checkbox"/> <input type="checkbox"/> <input type="checkbox"/> <input type="checkbox"/> <input type="checkbox"/> <input type="checkbox"/> <input type="checkbox"/> <input type="checkbox"/>	108 - <input type="checkbox"/> <input type="checkbox"/> <input type="checkbox"/> <input type="checkbox"/> <input type="checkbox"/> <input type="checkbox"/> <input type="checkbox"/> <input type="checkbox"/>
X X X X X X X X X X X X X X X X	X X X X X X X X X X X X X X X X	0 0 0 0 0 0 0 0
110 - <input type="checkbox"/>	116 - <input type="checkbox"/>	
0	0	
121 - <input type="checkbox"/> <input type="checkbox"/>	123 - <input type="checkbox"/>	125 - <input type="checkbox"/> <input type="checkbox"/> <input type="checkbox"/> <input type="checkbox"/> <input type="checkbox"/> <input type="checkbox"/> <input type="checkbox"/> <input type="checkbox"/> <input type="checkbox"/> <input type="checkbox"/>
0 1	0	0 0 0 0 0 0 0 0 0 0
132 - <input type="checkbox"/> <input type="checkbox"/> <input type="checkbox"/> <input type="checkbox"/>	136 - <input type="checkbox"/> <input type="checkbox"/> <input type="checkbox"/> <input type="checkbox"/>	137 - <input type="checkbox"/> <input type="checkbox"/> <input type="checkbox"/> <input type="checkbox"/> <input type="checkbox"/> <input type="checkbox"/>
0 0 0 0	0 0 0 0	0 0 0 0 0 0
141 - <input type="checkbox"/>	165 - <input type="checkbox"/>	166 - <input type="checkbox"/> <input type="checkbox"/> <input type="checkbox"/> <input type="checkbox"/>
A	0	A 0 0 0
173 - <input type="checkbox"/> <input type="checkbox"/> <input type="checkbox"/> <input type="checkbox"/> <input type="checkbox"/> <input type="checkbox"/> <input type="checkbox"/> <input type="checkbox"/> <input type="checkbox"/>	175 - <input type="checkbox"/> <input type="checkbox"/> <input type="checkbox"/> <input type="checkbox"/> <input type="checkbox"/> <input type="checkbox"/>	178 - <input type="checkbox"/>
0 0 0 0 0 0 0 0 0 0	0 0 0 0 0 0	0
213 - <input type="checkbox"/>	215 - <input type="checkbox"/> <input type="checkbox"/> <input type="checkbox"/> <input type="checkbox"/> <input type="checkbox"/>	220 - <input type="checkbox"/>
1	0 0 0 0 0	0
380 - <input type="checkbox"/> <input type="checkbox"/> <input type="checkbox"/> <input type="checkbox"/>	381 - <input type="checkbox"/>	382 - <input type="checkbox"/> <input type="checkbox"/> <input type="checkbox"/> <input type="checkbox"/>
2 0 4 2	1	0 5 2 1
		383 - <input type="checkbox"/>
		2

- 106: Token-Ring Network Address of the 3174 (Token-Ring Network)
- 107: Token-Ring Network Address of the Gateway (Token-Ring Network)
- 108: Unique Machine Identifier
- 110: Multiple Logical Terminals (MLT) Configuration level
- 116: Individual Port Assignment
- 121: Keyboard Language and Character Set I/O Interface Code
- 123: Country Extended Code Page Support
- 125: Miscellaneous Feature Options
- 127: Response Time Monitor (RTM) Definition
- 132: Alternate Keyboard Selection
- 136: Modifiable Keyboards: Standard Layouts
- 137: Modifiable Keyboard: Modified Layouts
- 138: Modifiable Keypad: Standard Layouts
- 141: Magnetic Character Set
- 165: Compressed Program Symbols
- 166: Attribute Select Keyboard
- 168: Additional Extension-Mode Key Definition
- 173: Distributed Function Terminal (DFT) Options
- 175: Distributed Function Terminal (DFT) Password
- 178: 7232 Dual Control Unit Terminal Multiplexer Switching
- 213: Between Bracket Printer Sharing (SDLC, X.25, X.21 Switched, Local SNA, Token-Ring Network)
- 215: Physical Unit Identification (SDLC, X.25, X.21 Switched, Local SNA, Token-Ring Network)
- 220: Alert Function (SDLC, X.25, X.21 Switched, Local SNA, Token-Ring Network)
- 380: Maximum Receive I-Frame Size (Token-Ring Network)
- 381: Token-Ring Network Maximum In
- 382: Maximum Transmission I-Frame Size (Token-Ring Network)
- 383: Token-Ring Network Maximum Out

Worksheet 9—Token-Ring Gateway

Chapter 9 of the *3174 Customizing Guide* contains the planning information needed.

_____ Token-Ring Gateway _____

900 -
 X X X X X X X X X X X X

905 -
 1

908 -
 I B M L A N

- 900: Token-Ring Network Address for the Gateway
- 905: Ring Error Monitor (REM)
- 908: Link Subsystem Name

Worksheet 12—117: Port Assignment

Chapter 4 of the 3174 Customizing Guide contains the planning information needed.

117: Port Assignment

C@	#IS	P	LT1 S1	LT2 S2	LT3 S3	LT4 S4	LT5
26-00	—	—	—	—	—	—	—
26-02	—	—	—	—	—	—	—
26-04	—	—	—	—	—	—	—
26-06	—	—	—	—	—	—	—
26-08	—	—	—	—	—	—	—
26-10	—	—	—	—	—	—	—
26-12	—	—	—	—	—	—	—
26-14	—	—	—	—	—	—	—
26-16	—	—	—	—	—	—	—
26-18	—	—	—	—	—	—	—
26-20	—	—	—	—	—	—	—
26-22	—	—	—	—	—	—	—
26-24	—	—	—	—	—	—	—
26-26	—	—	—	—	—	—	—
26-28	—	—	—	—	—	—	—
26-30	—	—	—	—	—	—	—
21-00	—	—					
21-02	—	—					
21-04	—	—					
21-06	—	—					
22-00	—	—					
22-02	—	—					
22-04	—	—					
22-06	—	—					
23-00	—	—					
23-02	—	—					
23-04	—	—					
23-06	—	—					

C@	#IS	P	LT1 S1	LT2 S2	LT3 S3	LT4 S4	LT5
26-01	—	—	—	—	—	—	—
26-03	—	—	—	—	—	—	—
26-05	—	—	—	—	—	—	—
26-07	—	—	—	—	—	—	—
26-09	—	—	—	—	—	—	—
26 11	—	—	—	—	—	—	—
26-13	—	—	—	—	—	—	—
26-15	—	—	—	—	—	—	—
26-17	—	—	—	—	—	—	—
26-19	—	—	—	—	—	—	—
26-21	—	—	—	—	—	—	—
26-23	—	—	—	—	—	—	—
26-25	—	—	—	—	—	—	—
26-27	—	—	—	—	—	—	—
26-29	—	—	—	—	—	—	—
26-31	—	—	—	—	—	—	—
21-01	—	—					
21-03	—	—					
21-05	—	—					
21-07	—	—					
22-01	—	—					
22-03	—	—					
22-05	—	—					
22-07	—	—					
23-01	—	—					
23-03	—	—					
23-05	—	—					
23-07	—	—					

Worksheet 13—128: RTM

Planner: Chapter 5 of the 3174 Customizing Guide contains the planning information needed.

Circle the name that indicates the response you want to specify. If you circle Version A or Version B, write your responses on the panel.

Default Values

Version A

128: RTM Definition

B1	<input type="checkbox"/> 00	<input type="checkbox"/> 01	<input type="checkbox"/> 0
B2	<input type="checkbox"/> 00	<input type="checkbox"/> 02	<input type="checkbox"/> 0
B3	<input type="checkbox"/> 00	<input type="checkbox"/> 05	<input type="checkbox"/> 0
B4	<input type="checkbox"/> 00	<input type="checkbox"/> 10	<input type="checkbox"/> 0

Version B

128: RTM Definition

F1-00000000

B1	<input type="checkbox"/> 00	<input type="checkbox"/> 01	<input type="checkbox"/> 0
B2	<input type="checkbox"/> 00	<input type="checkbox"/> 02	<input type="checkbox"/> 0
B3	<input type="checkbox"/> 00	<input type="checkbox"/> 05	<input type="checkbox"/> 0
B4	<input type="checkbox"/> 00	<input type="checkbox"/> 10	<input type="checkbox"/> 0

Worksheet 14—X.25 Options

Chapter 6 of the *3174 Customizing Guide* contains the planning information needed.

332: X.25 Options

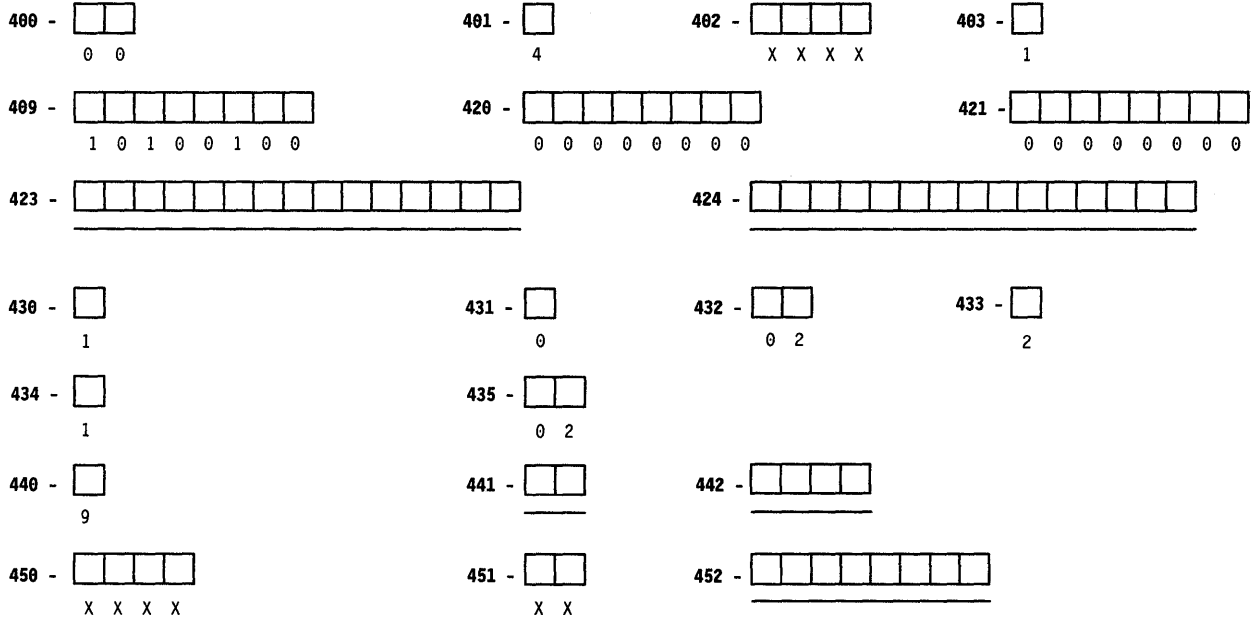

- 400: Network Type
- 401: Circuit Type
- 402: Logical Channel Identifier
- 403: Logical Link Control
- 409: X.25 Keyboard Support Options
- 420: Incoming Call Options
- 421: Outgoing Call Options
- 423: Host DTE Address (HNAD)
- 424: 3174 DTE Address
- 430: Negotiated Packet Size (NPKT)
- 431: Packet Sequence Numbering
- 432: Negotiated Window Size (NWND)
- 433: K-Maximum Out
- 434: Nonstandard Default Packet Size (DPKT)
- 435: Nonstandard Default Window Size (DWND)
- 440: Throughput Class Negotiation (TCLS)
- 441: Closed User Group (CUG)
- 442: Recognized Private Operating Agency (RPOA)
- 450: Link Level Transmit Timeout
- 451: Number of Retries
- 452: Connection Identifier Password (CID)

Worksheet 15—Printer Authorization Matrix (PAM)

Chapter 10 of the *3174 Customizing Guide* contains the planning information needed.

Entry	PAM Definition															
	Printer Port				Mode	Class										
	7	8				0		1		2						
	0	1	2	3	4	5	6	7	8	9	0	1	2	3	4	5
-	-	-	-	-	-
-	-	-	-	-	-
-	-	-	-	-	-
-	-	-	-	-	-
-	-	-	-	-	-

Entry	TA Display Port										AEA Display Port									
	26					21					22					23				
	0	1				2	3	0				0	0							
	0	1	2	3	4	5	6	7	8	9	0	1	2	3	4	5	6	7	8	9
-
-
-
-
-

Worksheet 16—3270 Attachment Diagram

Chapter 8 of the 3174 Customizing Guide contains the planning information needed.

Terminal Adapter HG-26	Port Set Name	Station Set Name	Default Destinations					Station Type
			LT1	LT2	LT3	LT4	LT5	
26-00								
26-01								
26-02								
26-03								
26-04								
26-05								
26-06								
26-07								
26-08								
26-09								
26-10								
26-11								
26-12								
26-13								
26-14								
26-15								
26-16								
26-17								
26-18								
26-19								
26-20								
26-21								
26-22								
26-23								
26-24								
26-25								
26-26								
26-27								
26-28								
26-29								
26-30								
26-31								

Station Set Name	Station Set Number
IBM Host =	= 1
ASCII Host =	=
ASCII Host =	=
ASCII Host =	=
ASCII Host =	=
ASCII Host =	=
ASCII Host =	=
ASCII Host =	=
ASCII Host =	=

Note:
For 3270 Stations
Port Type = Coax = 1

3270
Display = 3D
Printer = 3P

Worksheet 17—ASCII Attachment Diagram

Chapter 8 of the 3174 Customizing Guide contains the planning information needed.

Switched = 2 Direct = 3 Non-switched = 4		Hayes* = 1 Micom* = 2 IBM = 3 Other = 4		Station Set Name IBM Host = ASCII Host = ASCII Host = ASCII Host = ASCII Host = ASCII Host = ASCII Host = ASCII Host = ASCII Host =	Station Set Number = 1 = = = = = = =	See Station Type Table below
Port Type	Modem Type	Port Set Name	Station Set Name	Default Destination	Station Type	

AEA HG-21

21-00					
21-01					
21-02					
21-03					
21-04					
21-05					
21-06					
21-07					

AEA HG-22

22-00					
22-01					
22-02					
22-03					
22-04					
22-05					
22-06					
22-07					

AEA HG-23

23-00					
23-01					
23-02					
23-03					
23-04					
23-05					
23-06					
23-07					

Station Type Table *

ASCII Host = AH	FTTERM (Color) = FC	Lear Siegler ADM 11/12 = L1	Televideo 912 = T1
ASCII Printer = AP	FTTERM (Monochrome) = FM	Lear Siegler ADM 3A/5 = L3	Televideo 970 = T7
ADDS Viewpoint A-2 = A2	Hewlett Packard 2621 = H2	Lear Siegler 1178 = L7	DEC VT100 = V1
ADDS Viewpoint 78 = A7	IBM 3101 = I1	ANSI 3.64 Terminal = S1	DEC VT241 = V2
Esprit Hazeltine 1500 = E1	IBM 3161/3163 = I3		DEC VT52 = V5
Esprit 78 = E7	IBM 3164 = I4		

*Trademark acknowledgements can be found in Chapter 8 of the 3174 Subsystem Control Unit Customizing Guide, GA23-0214.

Worksheet 18—AEA Configure

Chapter 8 of the *3174 Customizing Guide* contains the planning information needed.

_____ AEA Configure _____

700 -
0

701 -

700: Configure the AEA Feature
701: Password for ASCII Displays on Switched Lines

Worksheet 19—AEA Port Set

Chapter 8 of the *3174 Customizing Guide* contains the planning information needed.

_____ AEA Port Set _____

	Name	Session Limit	Port Type	Modem Type
1	_____	_____	_____	_____
2	_____	_____	_____	_____
3	_____	_____	_____	_____
4	_____	_____	_____	_____
5	_____	_____	_____	_____
6	_____	_____	_____	_____
7	_____	_____	_____	_____
8	_____	_____	_____	_____
9	_____	_____	_____	_____
10	_____	_____	_____	_____
11	_____	_____	_____	_____
12	_____	_____	_____	_____
13	_____	_____	_____	_____
14	_____	_____	_____	_____
15	_____	_____	_____	_____
16	_____	_____	_____	_____

Worksheet 20—AEA Port to Port Set Map

Chapter 8 of the *3174 Customizing Guide* contains the planning information needed.

_____ AEA Port to Port Set Map _____

TA (HG = 26)	0	1	2	3	4	5	6	7
(0-7)	—	—	—	—	—	—	—	—
(8-15)	—	—	—	—	—	—	—	—
(16-23)	—	—	—	—	—	—	—	—
(24-31)	—	—	—	—	—	—	—	—
	0	1	2	3	4	5	6	7
AEA 1 (HG = 21):	—	—	—	—	—	—	—	—
AEA 2 (HG = 22):	—	—	—	—	—	—	—	—
AEA 3 (HG = 23):	—	—	—	—	—	—	—	—

Worksheet 21—AEA Station Set

Chapter 8 of the 3174 Customizing Guide contains the planning information needed.

————— AEA Station Set —————

721 - _____ 722 - 723 -

725 -
1

731 - 732 - 733 - 734 - 735 - 736 - 737 -
1 1 0 1 0 1

741 - 742 - 743 -
0 0 0 0 1 5 1

751 -
_____ 752 - _____

761 - 762 - 763 - 764 -
1 1 1 1

771 - 772 - 773 - 774 - 775 -
1 1 1 1 1

781 - 782 - 783 -
0 0 0 6 6

- 721: Station Set Name
- 722: Station Type
- 723: Port Set Name
- 725: Host Connection Menu Option
- 731: Flow Control Type
- 732: XON/XOFF Transmission Resumption Trigger
- 733: Line Speed
- 734: Line Speed (Host Upper Limit)
- 735: Parity
- 736: Stop Bits
- 737: Maximum Modem Line Speed
- 741: Switched Disconnect Timeout
- 742: Inactivity Timeout
- 743: Prompt for Universal/Specific Keyboard Map
- 751: Terminal Type Supported by the ASCII Host
- 752: ASCII Host Phone Number
- 761: Auto XON/XOFF
- 762: Wraparound Option
- 763: New Line Option
- 764: Margin Bell
- 771: Automatic Line Feed for Cursor Control
- 772: Carriage Return/Carriage Return - Line Feed Selection
- 773: Automatic New Line for Cursor Control
- 774: Scrolling
- 775: Line Turnaround Character
- 781: Attached Printer Prompt
- 782: Use of Form Feed
- 783: Page Length

Worksheet 22—AEA Default Destination

Chapter 8 of the 3174 *Customizing Guide* contains the planning information needed.

AEA Default Destination

Station Set	Station Set Name	Session Limit	Session				
			LT1	LT2	LT3	LT4	LT5
1	_____	_____	___	___	___	___	___
2	_____	_____	___	___	___	___	___
3	_____	_____	___	___	___	___	___
4	_____	_____	___	___	___	___	___
5	_____	_____	___	___	___	___	___
6	_____	_____	___	___	___	___	___
7	_____	_____	___	___	___	___	___
8	_____	_____	___	___	___	___	___
9	_____	_____	___	___	___	___	___
10	_____	_____	___	___	___	___	___
11	_____	_____	___	___	___	___	___
12	_____	_____	___	___	___	___	___
13	_____	_____	___	___	___	___	___
14	_____	_____	___	___	___	___	___
15	_____	_____	___	___	___	___	___
16	_____	_____	___	___	___	___	___
17	_____	_____	___	___	___	___	___
18	_____	_____	___	___	___	___	___
19	_____	_____	___	___	___	___	___
20	_____	_____	___	___	___	___	___
21	_____	_____	___	___	___	___	___
22	_____	_____	___	___	___	___	___
23	_____	_____	___	___	___	___	___
24	_____	_____	___	___	___	___	___
25	_____	_____	___	___	___	___	___
26	_____	_____	___	___	___	___	___
27	_____	_____	___	___	___	___	___
28	_____	_____	___	___	___	___	___
29	_____	_____	___	___	___	___	___
30	_____	_____	___	___	___	___	___

Worksheet 23—Multiple Logical Terminals

Chapter 3 of the 3174 *Customizing Guide* contains the planning information needed.

Control Unit Port Number	Device Type/ Screen Size	Session Limit	7232? Yes/No	EAB? Yes/No	MLT Storage Required
26-00					
26-01					
26-02					
26-03					
26-04					
26-05					
26-06					
26-07					
26-08					
26-09					
26-10					
26-11					
26-12					
26-13					
26-14					
26-15					
26-16					
26-17					
26-18					
26-19					
26-20					
26-21					
26-22					
26-23					
26-24					
26-25					
26-26					
26-27					
26-28					
26-29					
26-30					
26-31					
Total MLT Storage Required:					

Worksheet 24—Common SNA

Chapter 7 of the *3174 Customizing Guide* contains the planning information needed.

Common SNA

500 - <input style="width: 20px; height: 15px;" type="text"/>	501 - <table border="1" style="display: inline-table; border-collapse: collapse;"><tr><td style="width: 15px; height: 15px;"></td><td style="width: 15px; height: 15px;"></td><td style="width: 15px; height: 15px;"></td><td style="width: 15px; height: 15px;"></td><td style="width: 15px; height: 15px;"></td><td style="width: 15px; height: 15px;"></td><td style="width: 15px; height: 15px;"></td><td style="width: 15px; height: 15px;"></td><td style="width: 15px; height: 15px;"></td><td style="width: 15px; height: 15px;"></td></tr></table>											502 - <table border="1" style="display: inline-table; border-collapse: collapse;"><tr><td style="width: 15px; height: 15px;"></td><td style="width: 15px; height: 15px;"></td><td style="width: 15px; height: 15px;"></td><td style="width: 15px; height: 15px;"></td><td style="width: 15px; height: 15px;"></td><td style="width: 15px; height: 15px;"></td><td style="width: 15px; height: 15px;"></td><td style="width: 15px; height: 15px;"></td><td style="width: 15px; height: 15px;"></td><td style="width: 15px; height: 15px;"></td></tr></table>										
0																						

- 500: CSCM Unique
- 501: Network ID (NETID)
- 502: Logical Unit Name (LUNAME)

Non-Katakana Converged Keyboards

Chapter 11 of the 3174 Customizing Guide contains the planning information needed.

Language: _____

Keyboard ID: A B C D (circle one)

Modify Field: 1 = New Layout 2 = Update

Keyboard Type: 1 = Typewriter 2 = Data Entry 3 = APL

Keypad Type: 0 = National Language Numeric 1 = Data Entry 2 = Program Function (PF)

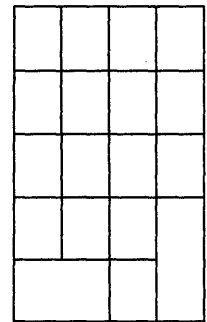
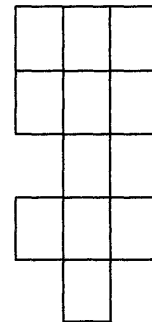
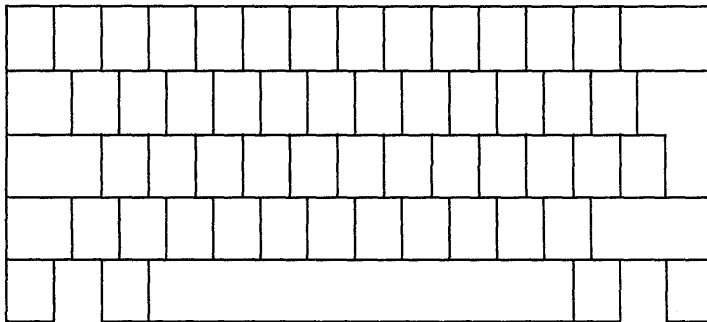

Keyboard, Shift, and Function Groups	From Key		I/O Interface		To Key	
	Shift	Character	Code	Character	Shift	Character
0 1 2 3 4 5 6 7 8						
0 1 2 3 4 5 6 7 8						
0 1 2 3 4 5 6 7 8						
0 1 2 3 4 5 6 7 8						
0 1 2 3 4 5 6 7 8						
0 1 2 3 4 5 6 7 8						
0 1 2 3 4 5 6 7 8						
0 1 2 3 4 5 6 7 8						
0 1 2 3 4 5 6 7 8						

0, 1, 2 - Keyboard Group

- 0 = The change made is on a Converged Typewriter, Converged Data Entry, or Enhanced Typewriter keyboard.
- 1 = The change made applies only to the APL key functions on a Converged APL keyboard.
- 2 = The change made applies to both the typewriter and APL functions of the keys involved on a Converged APL keyboard.

3, 4 - Shift Group

- 3 = Full-key change (includes alternate, upper, and lower shifts).
- 4 = Single-shift change.

5, 6, 7, 8 - Function Group

- 5 = The I/O interface code character has been copied to the To key.
- 6 = The two key functions have been exchanged.
- 7 = The function has been copied to the other key.
- 8 = The key function has been deleted.

Katakana Converged Keyboards

Chapter 11 of the 3174 Customizing Guide contains the planning information needed.

Language: _____
Keyboard ID: A B C D
 (circle one)

Modify Field:
 1 = New Layout
 2 = Update

Keyboard Type:
 1 = Typewriter
 2 = Data Entry
 3 = APL

Keypad Type:
 0 = National Language Numeric
 1 = Data Entry
 2 = Program Function (PF)

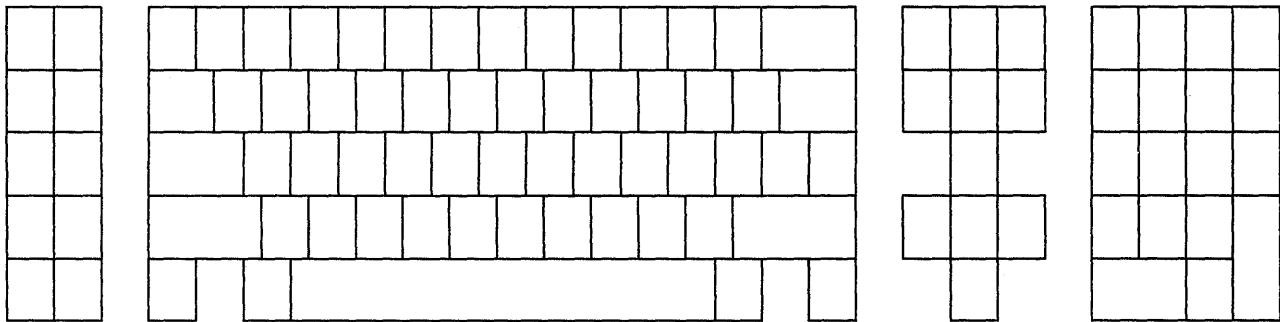
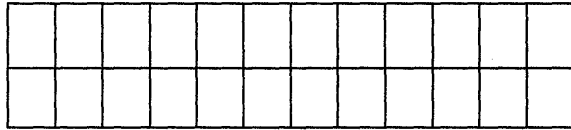

Keyboard, Shift, and Function Groups								From Key		I/O Interface		To Key	
								Shift	Character	Code	Character	Shift	Character
0	1	2	3	4	5	6	7	8					
0	1	2	3	4	5	6	7	8					
0	1	2	3	4	5	6	7	8					
0	1	2	3	4	5	6	7	8					
0	1	2	3	4	5	6	7	8					
0	1	2	3	4	5	6	7	8					
0	1	2	3	4	5	6	7	8					
0	1	2	3	4	5	6	7	8					
0	1	2	3	4	5	6	7	8					

0, 1, 2 - Keyboard Group

- 0 = The change made is on a Converged Typewriter, Converged Data Entry, or Enhanced Typewriter keyboard.
- 1 = The change made applies only to the APL key functions on a Converged APL keyboard.
- 2 = The change made applies to both the typewriter and APL functions of the keys involved on a Converged APL keyboard.

3, 4 - Shift Group

- 3 = Full-key change (includes alternate, upper, and lower shifts).
- 4 = Single-shift change.

5, 6, 7, 8 - Function Group

- 5 = The I/O interface code character has been copied to the To key.
- 6 = The two key functions have been exchanged.
- 7 = The function has been copied to the other key.
- 8 = The key function has been deleted.

Enhanced Keyboard (U.S.)

Chapter 11 of the 3174 Customizing Guide contains the planning information needed.

Language: _____
Keyboard ID: A B C D (circle one)
Modify Field: 1 = New Layout 2 = Update 4 = Typewriter
Keyboard Type: 4 = Typewriter
Keypad Type: 0 = National Language Numeric 1 = Data Entry 2 = Program Function (PF)

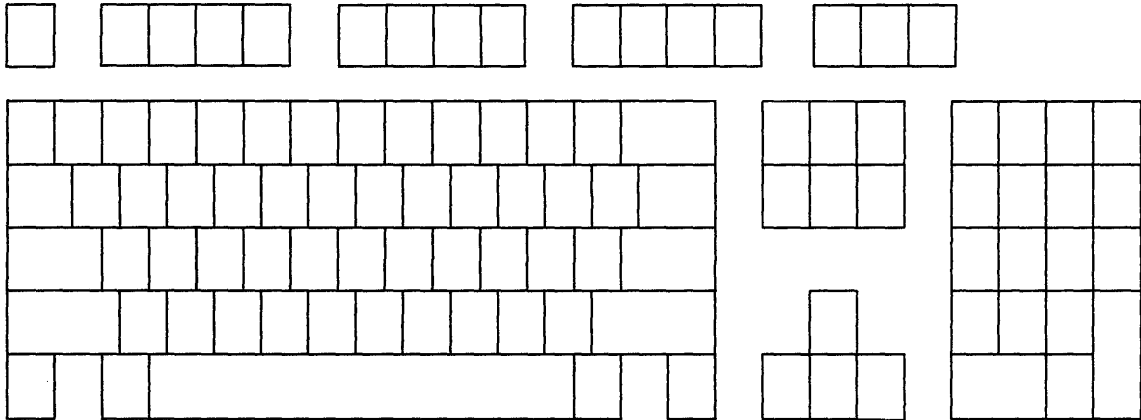

Keyboard, Shift, and Function Groups	From Key		I/O Interface		To Key	
	Shift	Character	Code	Character	Shift	Character
0 1 2 3 4 5 6 7 8						
0 1 2 3 4 5 6 7 8						
0 1 2 3 4 5 6 7 8						
0 1 2 3 4 5 6 7 8						
0 1 2 3 4 5 6 7 8						
0 1 2 3 4 5 6 7 8						
0 1 2 3 4 5 6 7 8						
0 1 2 3 4 5 6 7 8						
0 1 2 3 4 5 6 7 8						
0 1 2 3 4 5 6 7 8						

0, 1, 2 - Keyboard Group

- 0 = The change made is on a Converged Typewriter, Converged Data Entry, or Enhanced Typewriter keyboard.
- 1 = The change made applies only to the APL key functions on a Converged APL keyboard.
- 2 = The change made applies to both the typewriter and APL functions of the keys involved on a Converged APL keyboard.

3, 4 - Shift Group

- 3 = Full-key change (includes alternate, upper, and lower shifts).
- 4 = Single-shift change.

5, 6, 7, 8 - Function Group

- 5 = The I/O interface code character has been copied to the To key.
- 6 = The two key functions have been exchanged.
- 7 = The function has been copied to the other key.
- 8 = The key function has been deleted.

Enhanced Keyboard (World Trade)

Chapter 11 of the 3174 Customizing Guide contains the planning information needed.

Language: _____
Keyboard ID: A B C D
 (circle one)

Modify Field:
 1 = New Layout
 2 = Update

Keyboard Type:
 4 = Typewriter

Keypad Type:
 0 = National Language Numeric
 1 = Data Entry
 2 = Program Function (PF)

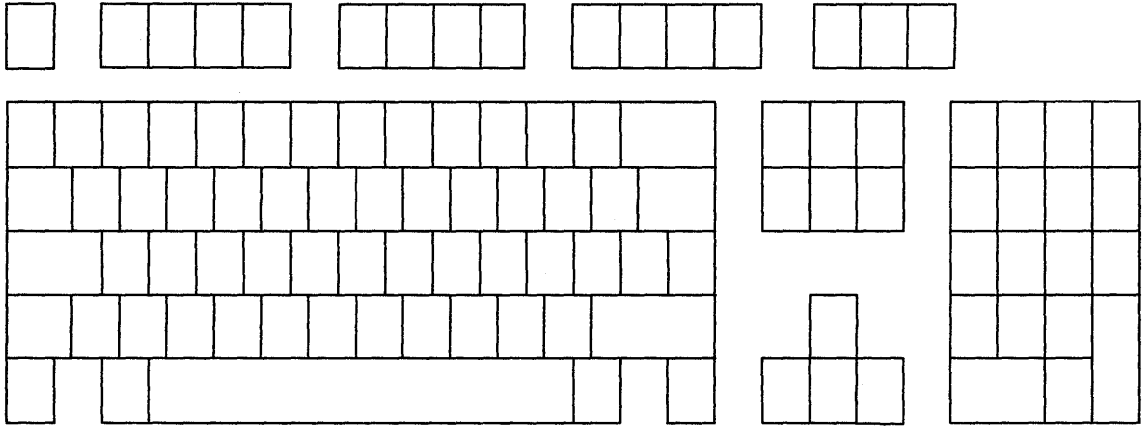

Keyboard, Shift, and Function Groups										From Key		I/O Interface		To Key	
										Shift	Character	Code	Character	Shift	Character
0	1	2	3	4	5	6	7	8							
0	1	2	3	4	5	6	7	8							
0	1	2	3	4	5	6	7	8							
0	1	2	3	4	5	6	7	8							
0	1	2	3	4	5	6	7	8							
0	1	2	3	4	5	6	7	8							
0	1	2	3	4	5	6	7	8							
0	1	2	3	4	5	6	7	8							
0	1	2	3	4	5	6	7	8							

0, 1, 2 - Keyboard Group

- 0 = The change made is on a Converged Typewriter, Converged Data Entry, or Enhanced Typewriter keyboard.
- 1 = The change made applies only to the APL key functions on a Converged APL keyboard.
- 2 = The change made applies to both the typewriter and APL functions of the keys involved on a Converged APL keyboard.

3, 4 - Shift Group

- 3 = Full-key change (includes alternate, upper, and lower shifts).
- 4 = Single-shift change.

5, 6, 7, 8 - Function Group

- 5 = The I/O interface code character has been copied to the To key.
- 6 = The two key functions have been exchanged.
- 7 = The function has been copied to the other key.
- 8 = The key function has been deleted.

Enhanced Keyboard (Katakana)

Chapter 11 of the 3174 Customizing Guide contains the planning information needed.

Language: _____
Keyboard ID: A B C D (circle one)
Modify Field: 1 = New Layout 2 = Update
Keyboard Type: 4 = Typewriter
Keypad Type: 0 = National Language Numeric 1 = Data Entry 2 = Program Function (PF)

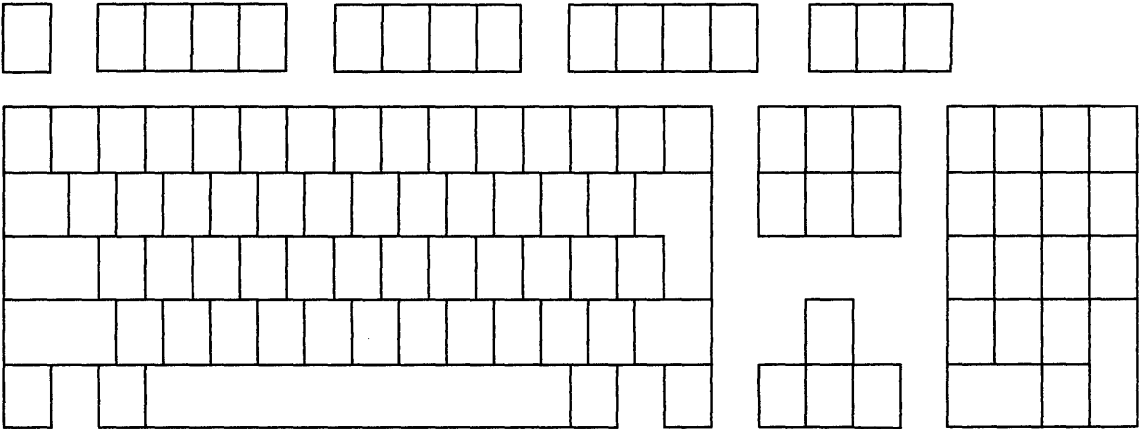

Keyboard, Shift, and Function Groups	From Key		I/O Interface		To Key	
	Shift	Character	Code	Character	Shift	Character
0 1 2 3 4 5 6 7 8						
0 1 2 3 4 5 6 7 8						
0 1 2 3 4 5 6 7 8						
0 1 2 3 4 5 6 7 8						
0 1 2 3 4 5 6 7 8						
0 1 2 3 4 5 6 7 8						
0 1 2 3 4 5 6 7 8						
0 1 2 3 4 5 6 7 8						
0 1 2 3 4 5 6 7 8						
0 1 2 3 4 5 6 7 8						

0, 1, 2 - Keyboard Group

- 0 = The change made is on a Converged Typewriter, Converged Data Entry, or Enhanced Typewriter keyboard.
- 1 = The change made applies only to the APL key functions on a Converged APL keyboard.
- 2 = The change made applies to both the typewriter and APL functions of the keys involved on a Converged APL keyboard.

3, 4 - Shift Group

- 3 = Full-key change (includes alternate, upper, and lower shifts).
- 4 = Single-shift change.

5, 6, 7, 8 - Function Group

- 5 = The I/O interface code character has been copied to the To key.
- 6 = The two key functions have been exchanged.
- 7 = The function has been copied to the other key.
- 8 = The key function has been deleted.

Configuration Questions Summary

Date: _____ Host: _____ Address: _____
 Model: _____ Circuit: _____ Location: _____
 Serial: _____ Line Speed: _____ Application Program: _____

099	Product Assistance Data	423	Host DTE Address
100	3174 Model Designation	424	3174 DTE Address
101	Host Attachment	430	Negotiated Packet Size
104	Control Unit Address	431	Packet Sequence Numbering
105	Upper Address Limit (Non-SNA or the Token-Ring Network 3270 Gateway Feature)	432	Negotiated Window Size
106	Token-Ring Network Address of the 3174 (Token-Ring Network)	433	K-Maximum Out
107	Token-Ring Network Address of the Gateway (Token-Ring Network)	434	Default Packet Size
108	Unique Machine Identifier	435	Default Window Size
110	Multiple Logical Terminals (MLT) Configuration Level	440	Throughput Class Negotiation
116	Individual Port Assignment	441	Closed Window Group
121	Language/Character/I/O	442	RPOA Number
123	Country Extended Code Page Support	450	Link Level Transmit Timeout
125	Miscellaneous Feature Options	451	Number of Retries
127	RTM Definition	452	CID Password
132	Alternate Keyboard Selection	500	CSCM Unique
136	Standard Modifiable Keyboard Layouts	501	Network ID
137	Modified Modifiable Keyboard Layouts	502	Logical Unit Name
138	Standard Modifiable Keypad Layouts	700	Configure the AEA Feature
141	Magnetic Character Set	701	Password for ASCII
165	Decompression	721	Station Set Name
166	Attribute Select Keyboard	722	Station Type
168	Additional Extension-Mode Key Definition	723	Port Set Name
173	3290 Options	725	Host Connection Menu Option
175	3290 Password	731	Flow Control Type
176	BSC Enhanced Communication Option	732	XON/XOFF Transmission Resumption Trigger
178	7232 Dual Control Unit Terminal Multiplexer Switching	733	Line Speed
213	Between Bracket Printer Sharing	734	Line Speed (ASCII Host Upper Limit)
215	Physical Unit Identification	735	Parity
220	Alert Function	736	Stop Bits
222	Support of Command Retry	737	Maximum Modem Line Speed
223	Attention Delay Value	741	Switched Disconnect Timeout
224	Mode of Data transfer	742	Inactivity Timeout
225	Channel Burst Size	743	Prompt for Universal/Specific Keyboard Map
310	Connect-Data-Set-to-Line Operation	751	Data Stream Supported by the ASCII Host
313	NRZ/NRZI Encoding	752	ASCII Host Phone Number
317	Switched Network Backup	761	Auto XON/XOFF
318	Full- or Half-Speed Transmission	762	Wraparound Option
340	RTS Control Options	763	New Line Option
360	X.21 Switched Retry	764	Margin Bell
361	X.21 Switched Retry Timing	771	Automatic Line Feed for Cursor Control
362	X.21 Switched Options	772	Carriage Return/Carriage Return Line Feed Selection
365	X.21 Switched DTE Connection	773	Automatic New Line for Cursor Control
367	X.21 Switched Short-Hold Mode	774	Scrolling
368	X.21 Switched Short-Hold Mode Dial Number	775	Line Turnaround Character
370	Maximum Inbound I-Frame Size	781	Attached Printer Prompt
380	Maximum Receive I-Frame Size	782	Use of Form Feed
381	Token-Ring Network Maximum In	783	Page Length
382	Maximum Transmission I-Frame Size	900	Token-Ring Network Address for the Gateway
383	Token-Ring Network Maximum Out	905	Ring Error Monitor (REM)
400	Network Type	908	Link Subsystem Name
401	Circuit Type	940	Ring Address Assignment
402	Logical Channel ID	941	Ring Transmission Definition
403	Logical Link Control		
409	X.25 Keyboard Support Options		
420	Incoming Call Options		
421	Outgoing Call Options		

Appendixes

Appendix A. Interutility Checking

Appendix B. Keyboard and Keypad Layouts

Appendix C. Limited Function Utility Disk

Appendix A. Interutility Checking

An Overview of Interutility Checking	A-3
PF Keys	A-3
Panel Informational Areas	A-4
Correcting Microcode Upgrade Errors	A-5
Correcting Customize Control Disk Errors	A-7

An Overview of Interutility Checking

During Interutility Checking, you will need the following:

- The completed configuration worksheets.
- The Status Codes in *3174 Status Codes*, GA27-3832.

The interutility checking function, displays the errors that occur because of conflicting responses between the customizing procedures. It informs the customizer of any errors or added procedures that need to be performed for the Microcode Upgrade, Customize Control Disk, and Central Site Customizing procedures.

For information on the panels displayed and the method used to correct the interutility errors for each of these procedures see the following:

- "Correcting Microcode Upgrade Errors" on page A-5
- "Correcting Customize Control Disk Errors" on page A-7
- For interutility checking of the Central Site Customizing procedure, see the *Central Site Customizing User's Guide*, GA23-0342.

PF Keys

The PF keys for the interutility checking program differ slightly from the PF keys used for the Microcode Upgrade and the Customize Control Disk procedures.

Some or all of these PF keys may appear on panels during the interutility checking program:

PF: 7=Back 10=Page Back 11=Page Fwd 12=File

PF7 Pressed during the interutility checking program while the Microcode Upgrade procedure is performed, PF7 (Back) returns the display to the Microcode Upgrade panel, from which the upgrade may be continued or ended.

Pressed during the interutility checking program while the Customize Control Disk procedure is performed, this key returns the display to the Customize Control Disk Menu.

PF10 PF10 (Page Back) pages back to the previous interutility checking panel.

PF11 PF11 (Page Forward) pages forward to the next interutility checking panel.

PF12 Pressed during the interutility checking program while the Customize Control Disk procedure is being performed, PF12 (File) files the customizing responses to the Control disk.

Note: Keyboards with PF13 through 24 are mapped into PF1 through PF12. For example, PF13 is PF1 and PF15 is PF3.

Interutility Checking

Panel Informational Areas

Each of the panels for the interutility checking programs has areas that provide information: instructions, operational information, and error information. See Figure A-1 for a description of these panel areas.

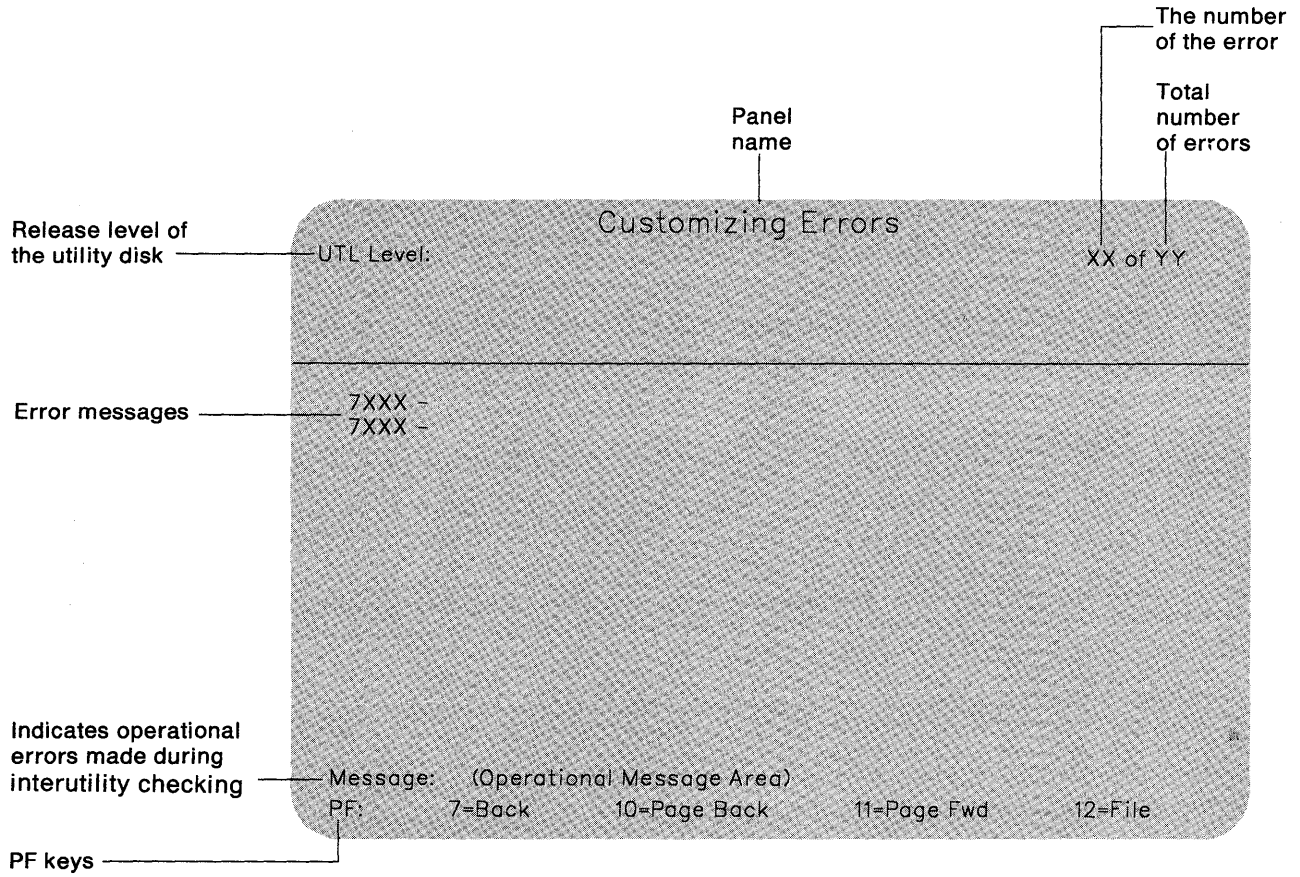

Figure A-1. The Interutility Checking Panel Information Areas

Correcting Microcode Upgrade Errors

After processing of the "Old" disk has started, the interutility checking panel (Figure A-2) may appear with one or more messages displayed if errors occurred or if additional procedures need to be performed. Figure A-1 on page A-4 shows the different informational areas found on the interutility checking panels.

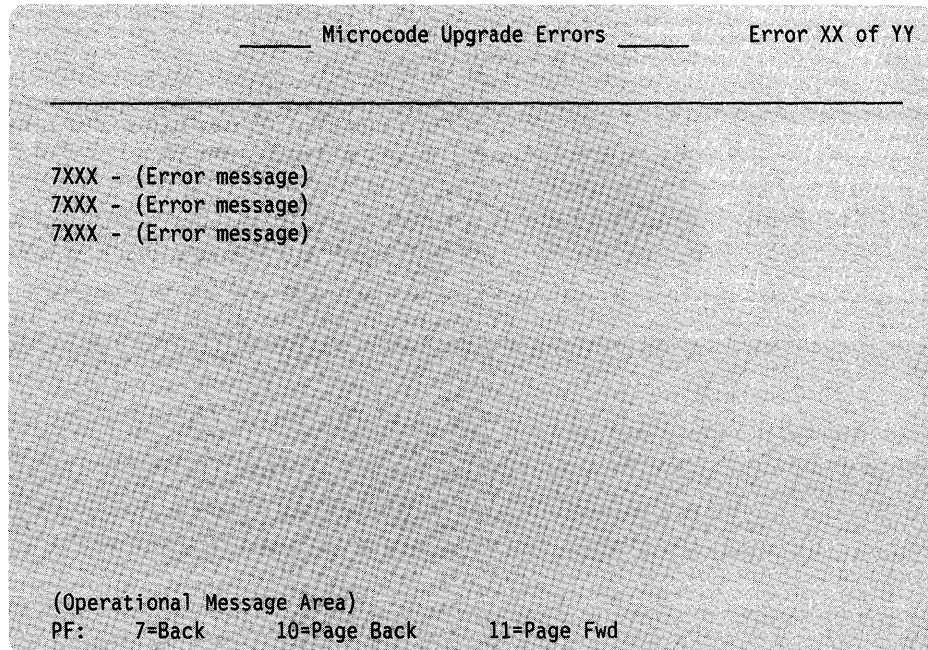

Figure A-2. Microcode Upgrade Errors Panel

Interutility Checking

Step 1. Print a Local Copy of Each Interutility Checking Panel

The errors discovered during the microcode upgrade and informational messages are displayed on the Interutility checking panels. It may be useful to print a local copy of these panels.

Note: Only non-ASCII printers can be used for the local copy at customization time.

1-1: Turn on a printer attached to the control unit.

1-2: Press the PRINT key.

1-3: Press the PF11 key to display the next panel and repeat step 1-2 until all the Interutility checking panels have been printed.

Step 2. Complete the Microcode Upgrade

2-1: Press PF7. The Microcode Upgrade panel is displayed.

2-2: If you are using a *diskette drive*, insert the "New" (or *To*) diskette into the drive and press ENTER. (A message is displayed when the upgrade is complete.)

If you are using a *fixed disk drive*, press ENTER. (A message is displayed when the upgrade is complete.)

2-3: Referring to the local copy of the interutility checking panel, correct the errors and perform any additional procedures on the New disk.

Correcting Customize Control Disk Errors

When either PF9 or PF12 is pressed from the Customize the Control Disk Menu, the interutility checking panel (Figure A-3) may appear if errors were made during customizing. Figure A-1 on page A-4 shows the different informational area found on the interutility checking panels.

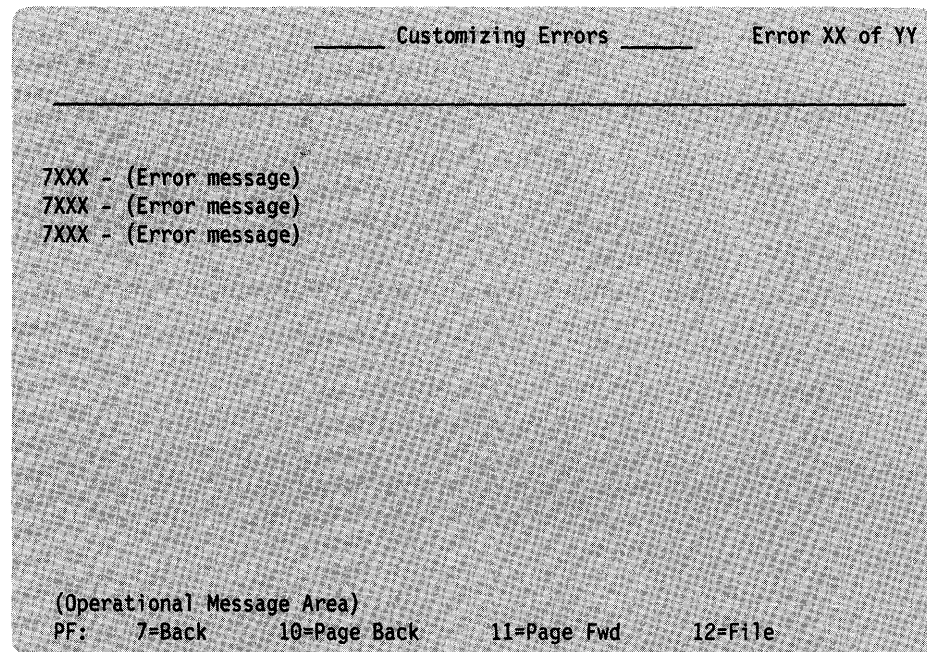

Figure A-3. Customizing Errors Panel

The errors listed may involve one or more procedures. For each procedure, perform the following steps to correct the errors.

Note: If you file the errors on the Control disk, certain control unit functions may not work the way that you intend them to.

Step 1. Print a Local Copy of Each Interutility Checking Panel

All of the errors discovered during Customizing are displayed on the Interutility checking panels. It may be useful to print a local copy of these panels.

Note: Only non-ASCII printers can be used for the local copy at customization time.

1-1: Turn on a printer attached to the control unit.

1-2: Press the PRINT key.

1-3: Press the PF11 key to display the next panel, and repeat step 1-2 until all the Interutility checking panels have been printed.

Step 2. Return to the Customizing Procedure That Contains Errors

2-1: Press PF7. The Customize the Control Disk Menu is displayed.

2-2: Select the proper procedure from the menu and press ENTER.

2-3: Referring to the local copy of the interutility checking panel, correct the invalid responses and press ENTER. The interutility checking errors indicate the invalid response(s).

2-4: If there are more panels in the procedure, press PF11 to advance to the next panel and correct any invalid responses. Press ENTER. (A message indicates whether the changed responses are valid.)

2-5: When all the errors have been corrected on the panels, press PF12 to file the responses. You will be returned to the Customize the Control Disk Menu. (You may want to press PF9 at this time, to ensure that your responses are valid.)

2-6: Perform steps 2-1 through 2-5 for each procedure listed on the local copy of the interutility checking panel.

Step 3. Press PF12 (Done) to File the Responses

If you have corrected all interutility checking errors, pressing PF12 will file the responses on the Control disk. If the interutility checking panel appears again, errors have been detected. Return to Step 1, or file the responses by pressing PF12 again. (You may want to file responses now and recustomize later to correct the errors.)

Appendix B. Keyboard and Keypad Layouts

Alternate Base Keyboard Selection (Question 132)	B-3
Modifiable Keyboards: Standard Layouts (Question 136)	B-5
Modifiable Keypads: Standard Layouts (Question 138)	B-7
Attribute Select Keyboards (Question 166)	B-8

Alternate Base Keyboard Selection (Question 132)

Your response to question 132 specifies the alternate keyboard layouts that you want configured. Keyboards 8K0808 and 8K0932 are mutually exclusive. If you select Keyboard 8K0808 or 8K0932, all standard Base Typewriter keyboards are replaced. If the 3174 control unit is customized for RPQ 8K0808 keyboards, 3270 terminal emulation will not work for ASCII display stations. If you select Keyboard 8K1158, all standard Base APL keyboards are replaced. See Figure B-1 through Figure B-4. The following Keyboards are applicable to models 3178, 3278, 3279, or devices that emulate these terminals.

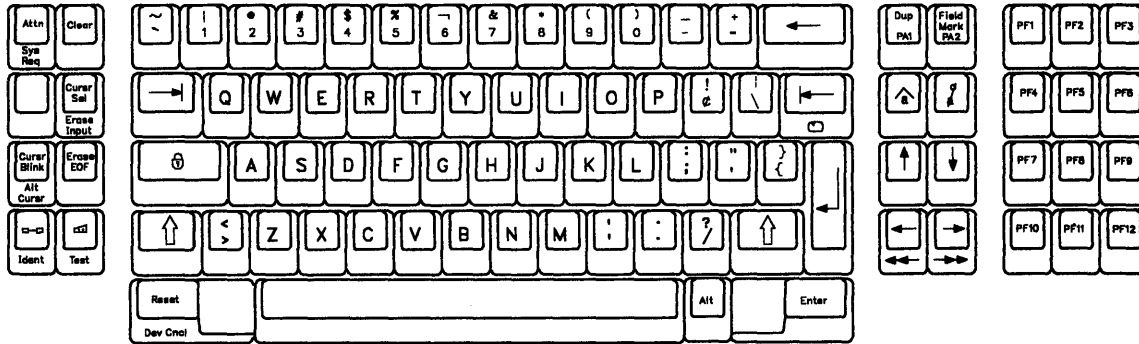

Figure B-1. Base Keyboard 8K0808

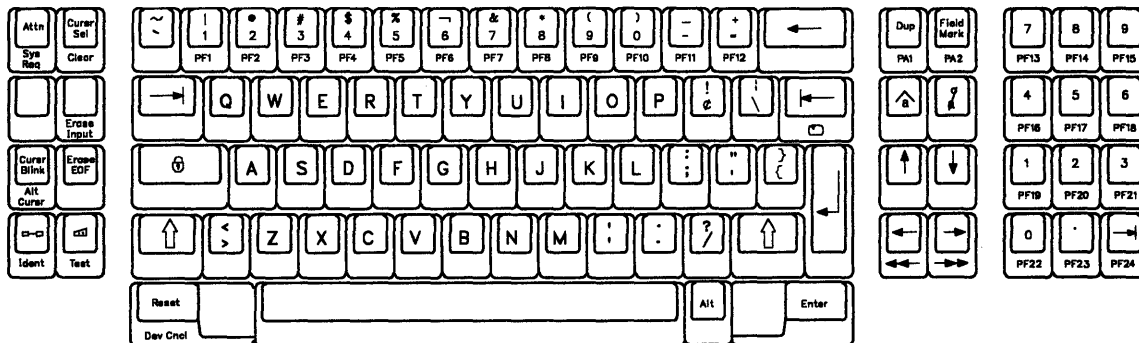

Figure B-2. Base Keyboard 8K0932 (Model C-4)

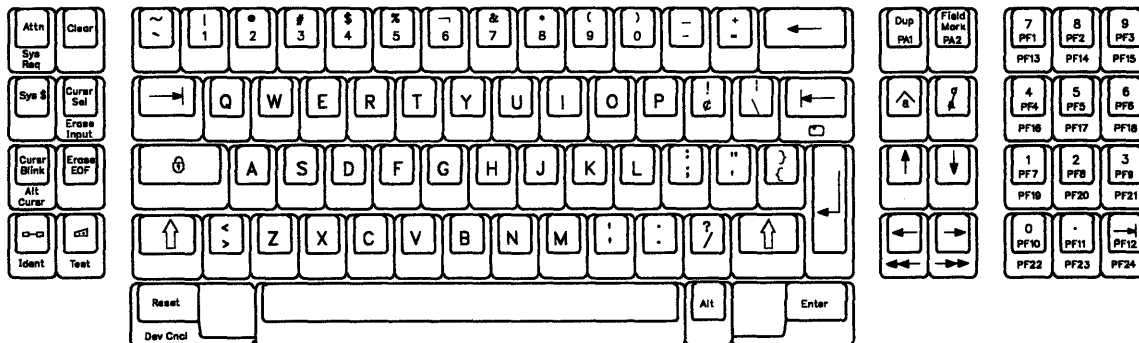

Figure B-3. Base Keyboard 8K1038 (Model C-3)

Keyboards and Keypads

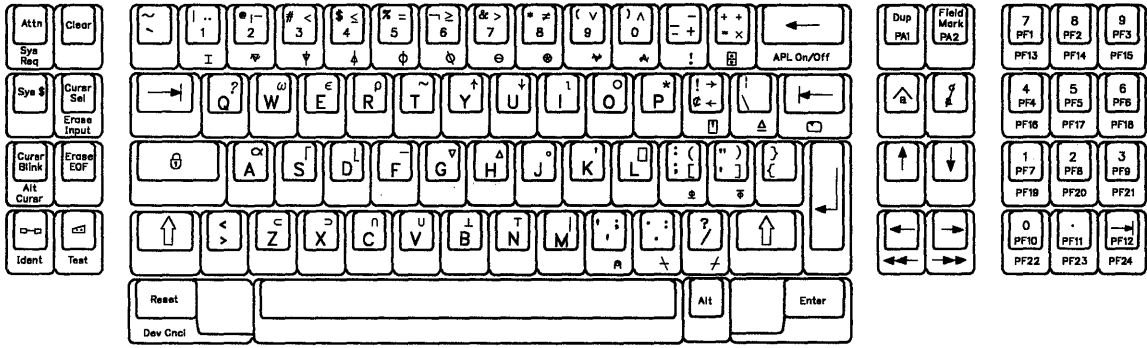

Figure B-4. Base Keyboard 8K1158

Modifiable Keyboards: Standard Layouts (Question 136)

Most keyboards are modifiable in native mode (see your terminal user's guide). If you do not want to modify the keyboard layout, during customization you can, select one of the standard layouts instead. There are four standard layouts: Converged Typewriter, Converged Data Entry (U.S. English only), Converged APL, and Enhanced Typewriter. Figures B-5 through B-8 are examples of these layouts.

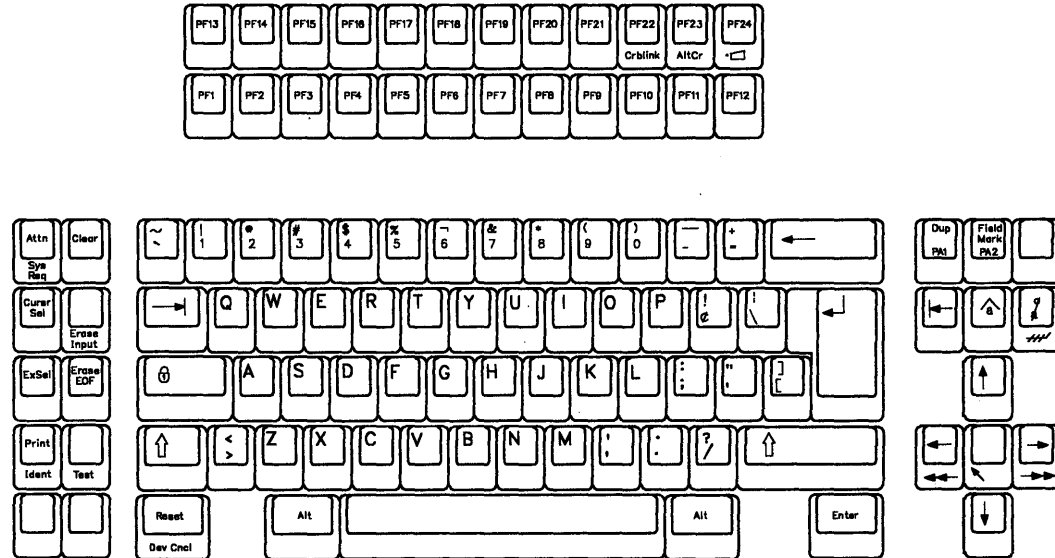

Figure B-5. Converged Typewriter Layout

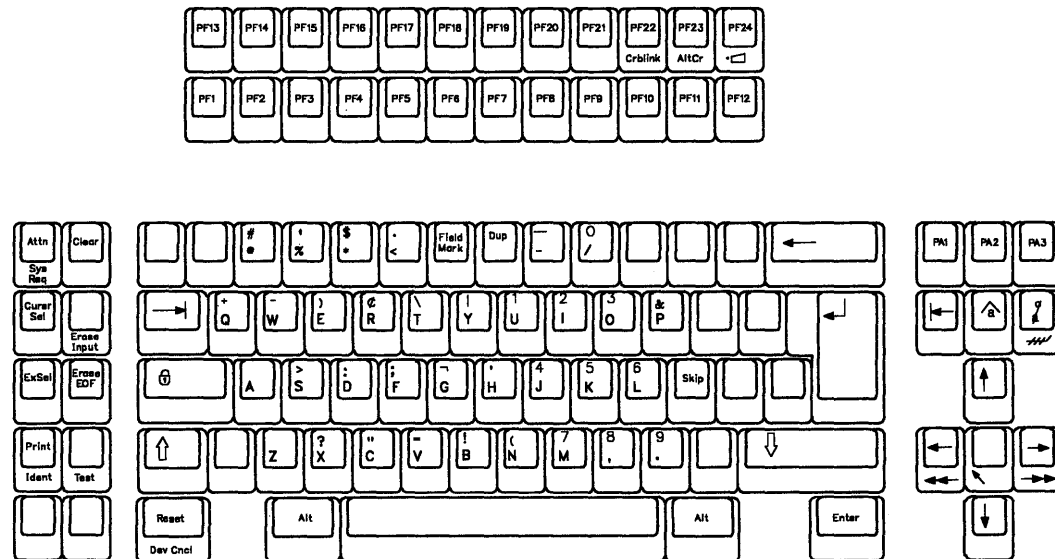

Figure B-6. Converged Data Entry Layout

Keyboards and Keypads

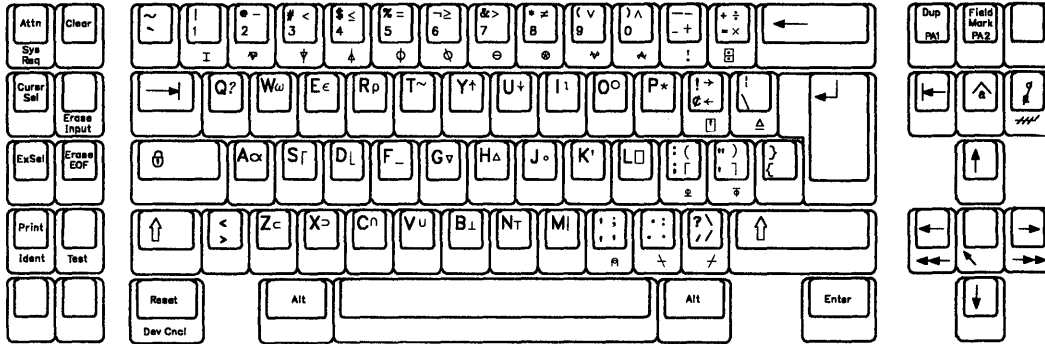
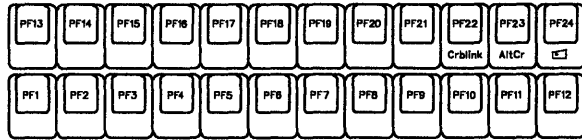

Figure B-7. Converged APL Layout

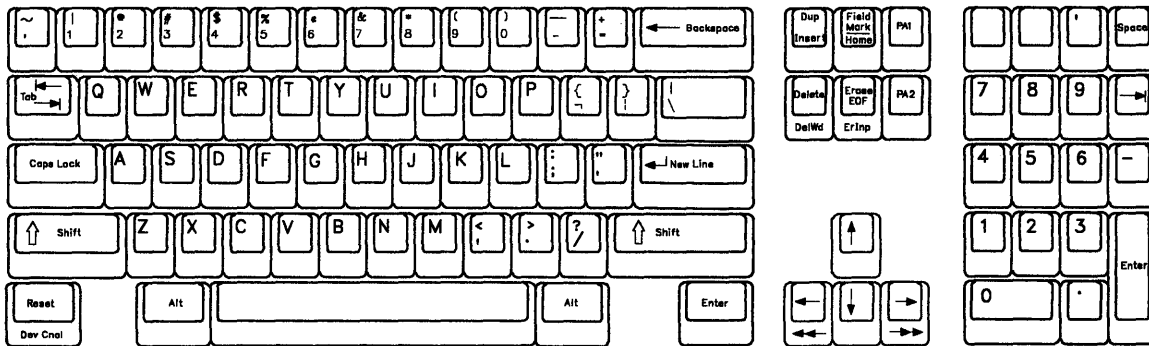
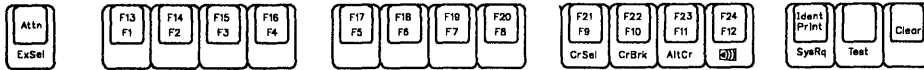
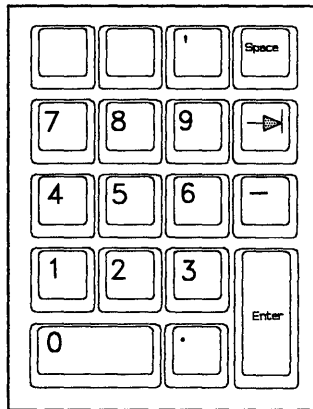

Figure B-8. Enhanced Typewriter Keyboard Layout

Modifiable Keypads: Standard Layouts (Question 138)

This question applies only to unmodified Converged or Enhanced keyboards in native mode (see your terminal user's guide). If the keyboard is being operated in emulation mode, this question does not apply for these display stations.

You can select from three standard keypad layouts (shown in Figure B-9): National Language Numeric, Data Entry, or Program Function.



National Language Numeric

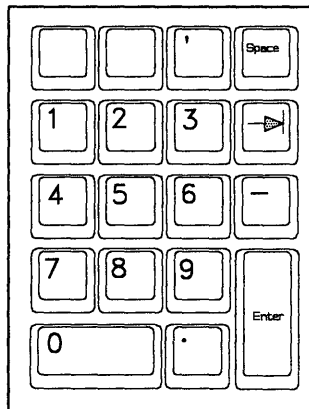

Data Entry

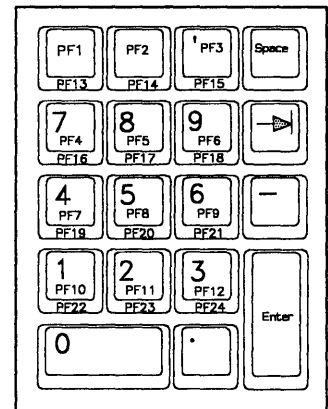

PF Keys

Figure B-9. Standard Keypad Layouts. The period and comma keytops switch positions on the keypad for some countries.

Attribute Select Keyboards (Question 166)

Your response to configuration question 166 specifies whether any of these keyboards is being used: Attribute Select Typewriter, Attribute Select Typewriter/APL, or Typewriter Overlay. (See Figure B-10 through Figure B-12.)

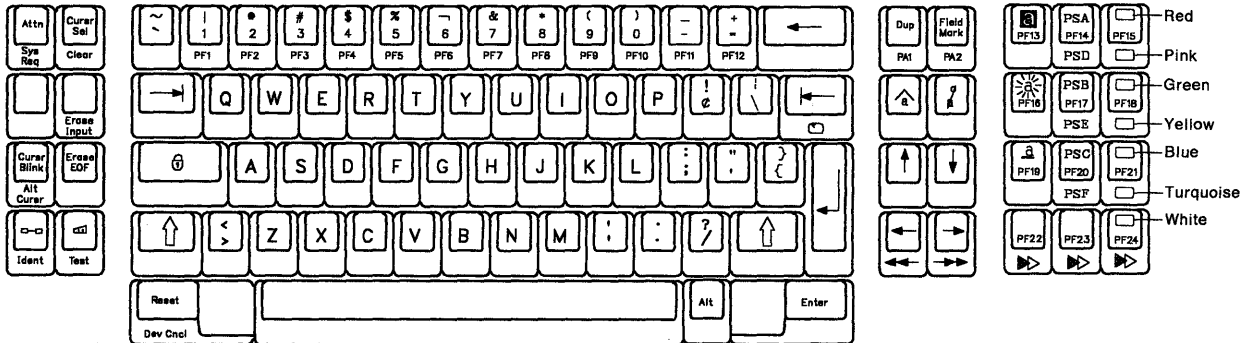

Figure B-10. The Attribute Select Typewriter Base Keyboard, Feature 4651 (U.S. English is shown as an example)

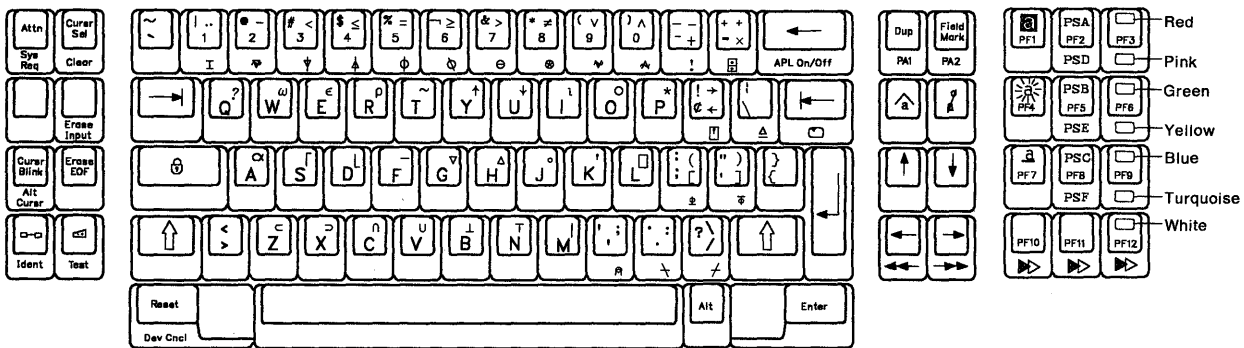

Figure B-11. The Attribute Select Typewriter/APL Base Keyboard, Feature 4652 (U.S. English is shown as an example)

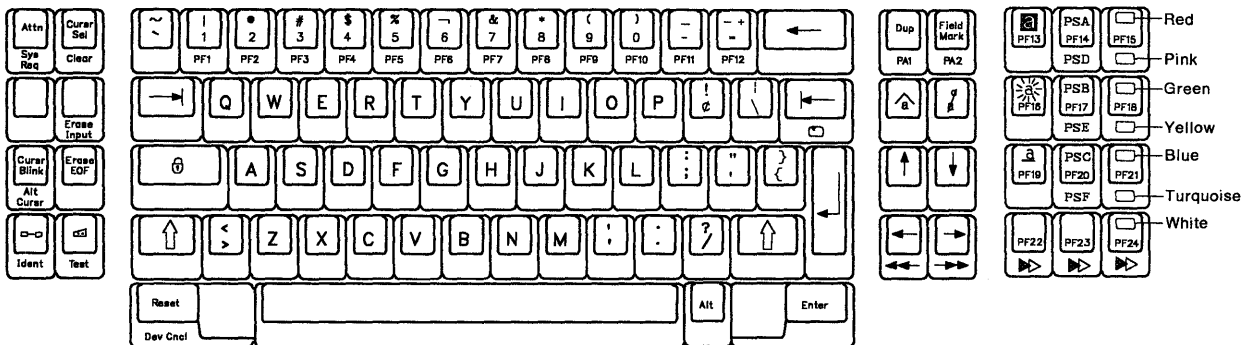

Figure B-12. The Typewriter Overlay Base Keyboard, Feature 4640 (U.S. English is shown as an example)

Appendix C. Limited Function Utility Disk

The Limited Function Utility Disk is used in networks that are under central site control. It is shipped with all of the control units that are ordered using specify code 9005 (called an *Inhibit Microcode Shipment*). It limits the options that can be performed and prevents the unauthorized reconfiguration of a control unit in the network. In a network that uses the Limited Function Utility Disk, all the control units are configured by the Central Site Control Unit.

Specify code 9005 would not be used in the order for the Central Site Control Unit, because that control unit will need the Utility and Control disk to perform all of the functions. Instead, the Central Site Control Unit can be ordered using specify code 9006, which is called *Central Site Diskette Distribution Aid*.

If you do have the Limited Function Utility disk, the Master Menu will look like the one shown in Figure C-1.

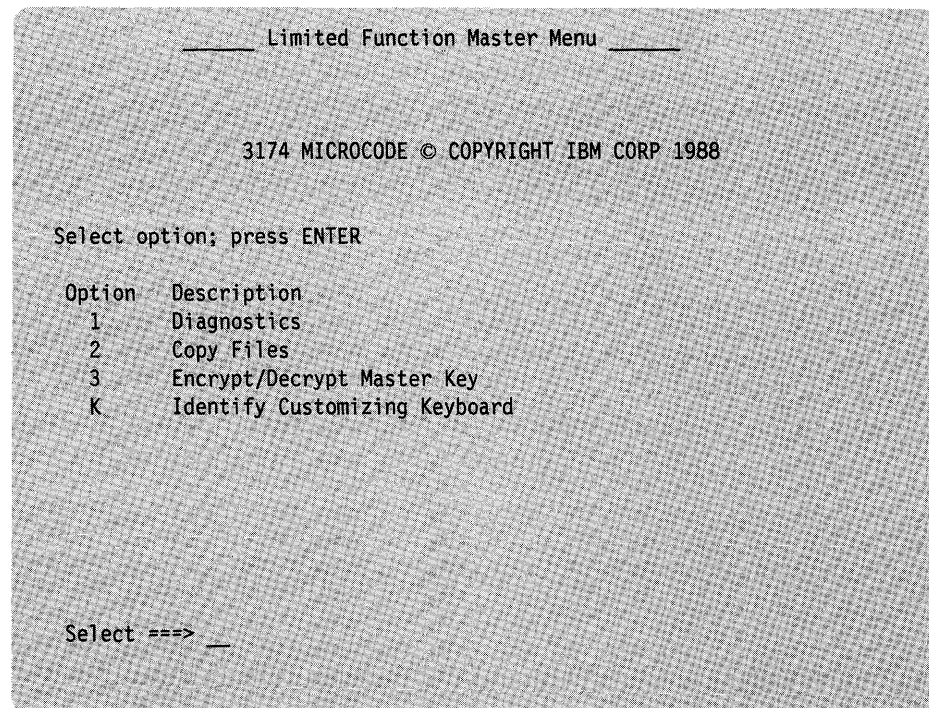

Figure C-1. The Limited Function Utility Master Menu

From it, any of the following can be performed:

- Diagnostics
- Copy Files
- Encrypt/Decrypt Master Key
- Identify Customizing Keyboard.

With the exception of the Copy option and the option numbers, the procedures are performed in the same way as they would be if you chose them from the Utility Disk Master Menu. The difference that you see when you perform the Copy option is on the Copy Menu. See Figure C-2.

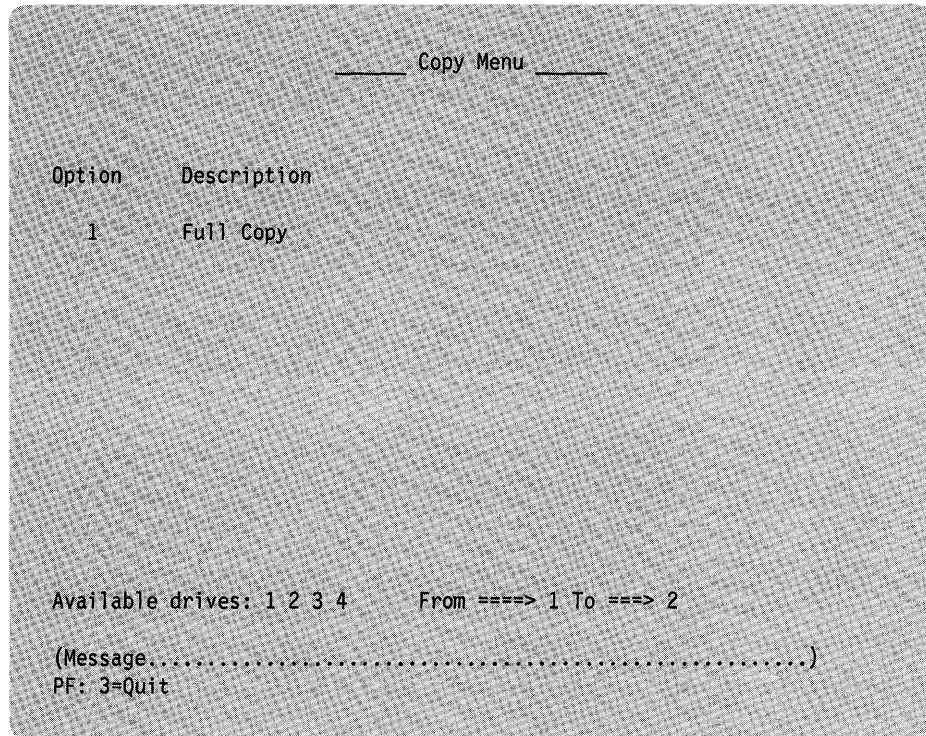

Figure C-2. Limited Function Utility Copy Menu after Option Selection

You are limited to the Full Copy option. However, you will still use the procedure discussed in Chapter 15, "How to Copy Files" to perform this option.

List of Abbreviations

A

ACF/TCAM. Advanced Communications Function for the Telecommunications Access Method

ACF/VTAM. Advanced Communications Function for the Virtual Telecommunications Access Method

AEA. Asynchronous Emulation Adapter.

AID. Attention identifier.

Alt. Alternate.

ANSI. American National Standards Institute.

APA. All points addressable.

APL. A Programming Language.

ASCII. American National Standard Code for Information Interchange.

ATTN. Attention.

B

bps. Bits per second.

BSC. Binary synchronous communication.

C

C&D. Cause and diagnostic (codes).

CC. Control check, Chain Command (flag).

CCC. Copy control character.

CCITT. International Telegraph and Telephone Consultative Committee.

CD. (1) Compact disk. (2) Change direction.

CECP. Country extended code page.

CID. Connection identifier.

CMS. Conversational monitor system.

cncl. Cancel.

coax. Coaxial (cable).

comm. Communication.

CR. Carriage Return.

CSCM. Central Site Change Management.

CSCU. Central Site Change Utility.

CSL. Central Site Library

CTL. Control.

CTS. Clear to Send.

CU. Control unit.

CUG. Closed user group.

CUT. Control unit terminal.

D

DCE. Data-circuit-terminating equipment.

DEL. The delete character.

DFT. (1) Distributed function terminal. (2) Diagnostic function test.

DISC. Disconnect.

DM. (1) Disconnect mode. (2) Distribution Manager.

DPKT. Default packet size.

Dsk. Diskette.

DSL. (1) Downstream load. (2) Data set label.

DSR. Data set ready.

DTE. Data terminal equipment.

DTR. Data terminal ready.

DWND. Default window size.

dup, DUP. Duplicate.

E

EAB. Extended Attribute Buffer.

EAU. Erase All Unprotected.

EB. End bracket.

Abbreviations

EBCDIC. Extended binary-coded decimal interchange code.

EC. Engineering change.

EM. End of message.

EOT. End-of-transmission character.

ETX. End of Text.

F

FCC. Federal Communications Commission.

FF. Forms feed.

FM. (1) Frequency modulation. (2) Function management. (3) Field mark.

H

hex. Hexadecimal.

HNAD. Host network (DTE) address.

I

ID. Identification, identifier.

Ident. Identification.

IML. Initial microcode load.

INS. Insert.

I/O. Input/output.

K

K. 1024.

KB. Kilobyte; 1024 bytes.

L

LFU. Limited Function Utility

LIB. Library

LIC. Last in chain.

LT. Logical terminal.

LU. Logical unit.

M

MAP. Maintenance analysis procedure.

MB. Megabyte; 1 048 576 bytes.

MB. Optical fiber mounting bracket.

MIS. Multiple interactive sessions.

MLT. Multiple logical terminals.

modem. Modulator-demodulator.

N

NCP. Network Control Program.

NPKT. Negotiated packet size.

NRZ. Nonreturn to zero.

NRZI. Nonreturn to zero inverted.

NSCU. Network Site Control Unit.

NUM. Numeric.

NWND. Negotiated window size.

O

OIA. Operator information area.

P

PA. (1) Program access. (2) Program attention.

PAM. Printer authorization matrix.

PC. Personal Computer.

PF. Program function.

PIU. Path information unit.

PLU. Primary logical unit.

PS. Programmed symbols.

PSH. Physical services header.

PSS. (1) Programmable Store System. (2) Programmed symbol set.

PU. Physical unit

PUID. Physical unit identification.

PVC. Permanent virtual circuit.

Q

QLLC. Qualified logical link control.

R

RH. Request/response header.

ROS. Read-only storage.

RPOA. Recognized private operating agency.

RPQ. Request for price quotation.

RTM. Response Time Monitor.

RTS. Request to send.

RU. Request/response unit.

S

SAP. Service access point.

SCS. SNA character string.

SDLC. Synchronous Data Link Control.

SNA. Systems Network Architecture.

SNBU. Switched network backup.

SP. (1) Space. (2) Specific Poll.

SSCP. System services control point.

SVC. Switched virtual circuit.

SYSGEN. System generation.

T

TA. Terminal adapter.

TCLS. Throughput class negotiation.

TH. Transmission header.

TP. Teleprocessing.

U

UKPSS. United Kingdom Packet Switched Service.

U.S. United States.

V

VTAM. Virtual Telecommunications Access Method.

W

WACK. Wait before transmit.

WCC. Write control character.

Abbreviations

Glossary

This glossary includes terms and definitions from the *IBM Dictionary of Computing: Information Processing, Personal Computing, Telecommunications, Office Systems, IBM-specific Terms*, SC20-1699.

The terms in this glossary are defined here as they apply to the 3270 Information Display System.

A

access method. A technique for moving data between main storage and input/output devices.

acknowledgment. The transmission, by a receiver, of acknowledge characters as an affirmative response to a sender.

active. Able to communicate on the network. An adapter is active if it is able to pass tokens on the network.

active logical terminal (LT). In MLT, the currently displayed logical terminal. Synonymous with *foreground logical terminal*. Contrast with *background logical terminal*.

adapter. A general term for a device that provides some transitional function between two or more devices.

address. (1) A value that identifies a register, a particular part of storage, a data source, or a data sink. The value is represented by one or more characters. (2) To refer to a device or an item of data by its address. (3) In word processing, the location, identified by an address code, of a specific section of the recording medium or storage. (4) The location in the storage of a computer where data is stored. (5) In data communication, the unique code assigned to each device or work station connected to a network.

AEA port. A communication connector on the Asynchronous Emulation Adapter (AEA).

AEA port set. (1) One or more 3174 ports that support individual AEA station sets; they must have the same port (connection) type and modem type, but different station types. (2) One or more 3174 station sets that have different station types, but the same port type, modem type, and number of default destinations.

AEA station. A 3270 or ASCII display station, printer, or host that communicates through the Asynchronous Emulation Adapter.

AEA station set. (1) One or more AEA stations that have the same attributes, for example, line speed and

parity. (2) One or more AEA stations that share the same characteristics of station type, port type, modem type, and default destination.

alert. (1) In the IBM Token-Ring Network Manager, a notification appearing on the bottom line of any panel to indicate an interruption or a potential interruption in the flow of data around the ring. (2) In NetView, a notification about a high-priority event that warrants immediate attention. This data-base record is generated for certain event types that are defined by user-constructed filters.

alternate cursor. (1) An image reversal of each dot in the character cell at the cursor position. (2) A cursor other than the one displayed on the display surface at power on time.

alternate 1 initial microcode load (Alt 1 IML). The action of loading the Utility microcode.

American National Standard Code for Information Interchange (ASCII). A standard code, using a coded character set consisting of 7-bit coded characters (8 bits including parity check), used for information interchange among data processing systems, data communication systems, and associated equipment. The ASCII set consists of control characters and graphic characters.

application. The use to which an information processing system is put, for example, a payroll application, an airline reservation application, or a network application.

application program. (1) A program written for or by a user that applies to the user's work, such as a program that does inventory control or payroll. (2) A program used to connect and communicate with stations in a network, enabling users to perform application-oriented activities.

ASCII emulation. The ability of a 3270 display station or printer to communicate with an ASCII host using the DEC VT100 or IBM 3101 data stream.

asynchronous. (1) Without regular time relationship; unexpected or unpredictable with respect to the execution of program instructions. (2) In asynchronous data transmissions, data characters may be sent or received at any time; no modem clocking is used to establish bit timing.

Asynchronous Emulation Adapter (AEA). In the 3174 Subsystem Control Unit, an adapter that enables an ASCII terminal to communicate with a 3270 host using the 3270 data stream, an ASCII terminal to communicate with an ASCII host through the 3174, and a 3270

Glossary

terminal to communicate with an ASCII host using the DEC VT100 data stream or the IBM 3101 data stream.

attach. To connect a device logically to a 3174 adapter, so that it can communicate over the network.

attachment feature. The circuitry by which a cable from a local terminal or a modem for a remote terminal is attached to a 3792 Auxiliary Control Unit or a 3791 Controller.

attention (ATTN). An occurrence external to an operation that could cause an interruption of the operation.

attention identifier (AID). (1) A code in the inbound 3270 data stream that identifies the source or type of data that follows. (2) A character in a data stream indicating that the user has pressed a key, such as Enter, that requests an action by the system.

attention key. A function key on terminals that, when pressed, causes an I/O interruption in the processing unit.

attribute. (1) A characteristic. (2) A terminal display language or transformation definition language (TDL) keyword that specifies a particular quality for the TDL object with which it is associated.

attribute select keyboard. A keyboard that enables the operator, when permitted by the program, to change the character attributes of the keyed-in character.

audible alarm. (1) An alarm that is sounded when designated events occur that require operator attention or intervention before system operation can continue. (2) A special feature that sounds a short, audible tone automatically when a character is entered from the keyboard into the next-to-last character position on the screen. The tone can also be sounded under program control.

autobaud. In the 3174 AEA feature, the process of determining the line speed and parity settings of a connecting display station from a specific sequence of characters (CR . CR) entered from the keyboard. ASCII hosts may also support automatic speed and parity detection, but the character sequence they require may differ.

B

backbone. In a multiple-ring local area network, a high-speed link to which the rings are connected by means of bridges. A backbone may be configured as a bus or as a ring.

background logical terminal (LT). In MLT, any logical terminal that is not currently displayed. Contrast with *active logical terminal (LT)*.

binary synchronous communications (BSC). Data transmission in which character synchronism is controlled by timing signals generated at the sending and receiving stations.

blink. An extended highlighting attribute value (for emphasis) of a field or character.

bracket. In SNA, one or more chains of request units (RUs) and their responses, which are exchanged between two LU-LU half-sessions and represent a transaction between them. A bracket must be completed before another bracket can be started. Examples of brackets are data base inquiries/replies, update transactions, and remote job entry output sequences to work stations.

bridge. (1) A functional unit that connects two local area networks (LANs) that use the same logical link control (LLC) procedure but may use different medium access control (MAC) procedures. (2) See also *backbone* and *gateway*.

Note: A bridge connects networks or systems of the same or similar architectures, whereas a gateway connects networks or systems of different architectures.

buffer. (1) A routine or storage used to compensate for a difference in rate of flow of data, or time of occurrence of events, when transferring data from one device to another. (2) An isolating circuit used to prevent a driven circuit from influencing the driving circuit. (3) To allocate and schedule the use of buffers. (4) A portion of storage used to hold input or output temporarily.

burst. (1) In data communication, a sequence of signals counted as one unit in accordance with some specific criterion or measure. (2) To separate continuous-form paper into discrete sheets.

bus. A type of network topology where the network consists of a bidirectional communication path with defined end points.

C

card. In the 3174 Subsystem Control Unit, a unit of electronic circuitry contained in a plastic casing (or cassette) and providing the control unit with a specialized function, for example, a Terminal Adapter or an Encrypt/Decrypt Adapter.

Central site change management (CSCM). A function of the 3174 microcode that tracks the microcode for each control unit in a network and, in conjunction with NetView DM, electronically distributes and retrieves microcode changes for each control unit.

central site customizing. The process of tailoring control unit microcode for each control unit in a network, at the central site.

central site library. One or more Library disks that contain customizing data and label information for the control units in a network.

channel-attached. Pertaining to attachment of devices directly by data channels (I/O channels) to a computer. Synonym for *local*. Contrast with *telecommunication-attached*.

channel-to-channel adapter. A hardware device that can be used to connect two channels on the same computing system or on different systems.

character position. A location on the screen at which one character can be displayed; also, an addressed location in the buffer at which one character can be stored.

character set. (1) A defined collection of characters. (2) A group of characters used for a specific reason, for example, the set of characters a printer can print. (3) The collection of graphic characters required to support a specific language.

Clear to Send (CTS) flow control. A procedure for a communicating device to signal its readiness to receive data by raising the CTS lead on an EIA 232D interface.

closed path (or network). A network in which all the cable paths and wiring closets are directly or indirectly connected.

cluster. A station that consists of a control unit (a cluster controller) and the terminals attached to it.

cluster controller. A device that can control the input/output operations of more than one device connected to it. A cluster controller may be controlled by a program stored and executed in the unit, for example, the IBM 3601 Finance Communication Controller. Or, it may be entirely controlled by hardware, for example, the IBM 3272 Control Unit. See also *cluster* and *cluster controller node*. Synonymous with *cluster control unit*.

cluster controller node. A peripheral node that can control a variety of devices. See also *host node*, *NCP node*, and *terminal node*.

cluster control unit. Synonym for cluster controller.

code page. An assignment of graphic characters and control function meanings to all code points.

command. An instruction that directs a control unit or device to perform an operation or a set of operations.

command retry. A channel and control unit procedure that causes a command to be retried without requiring an I/O interruption.

communication adapter. (1) A circuit card with associated software that enables a processor, controller, or other device to be connected to a network. (2) See *EIA communication adapter*, *V.35 communication adapter*, and *X.21 communication adapter*.

communication controller. (1) A device that directs the transmission of data over the data links of a network; its operation may be controlled by a program processed in a processor to which the controller is connected or by a program executed within the device. (2) A type of communication control unit whose operations are controlled by one or more programs stored and executed in the unit. It manages the details of line control and the routing of data through a network. (3) See also *cluster controller*, *communication controller node*, and *transmission control unit*.

communication controller node. A subarea node that does not contain a system services control point (SSCP).

communication control unit. A communication device that controls transmission of data over lines in a network.

configuration. The arrangement of a computer system or network as defined by the nature, number, and chief characteristics of its functional units. More specifically, the term *configuration* may refer to a hardware configuration or a software configuration. See also *system configuration*.

Connection Menu. A menu on the screen of a display station attached to the 3174 Subsystem Control Unit, from which a user can select an available host.

control character. (1) A character whose occurrence in a particular context specifies a control function. (2) A character used to specify that a control unit is to perform a particular operation.

Control (CTL) disk. A customized diskette or fixed disk containing the microcode that describes a particular control unit's attached terminals, and its method of attachment to the host.

Control (CTL) diskette. A customized diskette containing the microcode that describes a particular control unit's attached terminals, and its method of attachment to the host.

controller. A unit that controls input/output operations for one or more devices.

control unit. A general term for any device that provides common functions for other devices or mechanisms. The 3174 is an example of a control unit.

Glossary

control unit terminal (CUT). A terminal that relies on the 3174 to interpret the data stream. Examples are the 3178, 3179, 3278 Model 2, and 3279 Model S2A.

control unit terminal (CUT) mode. A host-interactive mode that enables an IBM 3270 Personal Computer customized in this mode to run only one session emulating a 3178, 3179, 3278 Model 2, or 3279 Model S2A.

conversion. (1) In programming languages, the transformation between values that represent the same data item but belong to different data types. Information may be lost as a result of conversion because accuracy of data representation varies among different data types. (2) The process of changing from one method of data processing to another or from one data processing system to another. (3) The process of changing from one form of representation to another, for example, to change from decimal representation to binary representation.

copy control character (CCC). A character used in conjunction with the Copy command to specify the type of data to be copied.

copy operation. An operation that copies the contents of the buffer from one terminal to another terminal attached to the same control unit.

country extended code page (CECP). A function of the 3174 microcode that provides for a code page containing additional code points beyond those available with Table 5A code pages. CECP is supported by a universal character set, Character Set 697, which contains 190 characters.

create. In 3174 central site customizing, to create a library member for a network control unit, and store the customizing data for that library member on a Library diskette.

cursor. (1) A movable, visible mark used to indicate the position at which the next operation will occur on a display surface. (2) A unique symbol that identifies a character position in a screen display, usually the character position at which the next character to be entered from the keyboard will be displayed.

customization. Procedures that tailor the control unit microcode to fit the various types of display stations and printers and the method of host attachment that a particular control unit will handle.

customizing display station. A display station used to perform the customizing procedures; this display station must be attached to port 26-00 of the control unit. Only these display stations can be used for customizing: a 3178, a 3179 Model 1 operating in native or 3279-emulation mode, a 3180 operating in native or 3278-emulation mode, a 3191, a 3192, a 3194 operating in control unit terminal (CUT) mode, a 3270 Personal Computer with 3276/3279 emulation, operating in CUT

mode, a 3278 (except Model 1), a 3279, a 5550 family operating in CUT mode, a 6150 RT Personal Computer, and a 6151 RT Personal Computer.

customizing keyboard. A keyboard used to type in the customizing responses; this keyboard must be a Typewriter, Data Entry, APL (with APL off), or Text (with Text off) keyboard with a QWERTY layout. On a QWERTY layout, the first six characters on the left side of the top row of alphabetic characters are Q, W, E, R, T, Y.

D

data circuit-terminating equipment (DCE). In a data station, the equipment that provides the signal conversion and coding between the data terminal equipment (DTE) and the line.

Notes:

1. The DCE may be separate equipment or an integral part of the DTE or of the intermediate equipment.
2. A DCE may perform other functions that are usually performed at the network end of the line.

Data Entry keyboard. A keyboard layout designed for data entry applications.

data link. Any physical link, such as a wire or a telephone circuit, that connects one or more devices or communication controllers.

data processing (DP). The systematic performance of operations upon data; for example, handling, merging, sorting, computing.

data stream. (1) All data transmitted through a data channel in a single read or write operation. (2) A continuous stream of data elements being transmitted, or intended for transmission, in character or binary-digit form, using a defined format. See also *data stream format*.

data stream format. In SNA, the format of the data elements (end-user data) in the request unit (RU). See also *3270 data stream* and *SNA character string (SCS)*.

data terminal equipment (DTE). That part of a data station that serves as a data source, data sink, or both.

Data Terminal Ready (DTR) flow control. A procedure for a communicating device to signal its readiness to receive data by raising the DTR lead on an EIA 232D interface.

data transfer. The movement, or copying, of data from one location and the storage of the data at another location.

decrypt. To convert encrypted data into clear data. Contrast with *encrypt*.

default destination. A destination for display stations and printers that is defined in customization.

default response. A response supplied by the customizing program if a different response is not specified during customization.

device. A mechanical, electrical, or electronic contrivance with a specific purpose.

disk. A direct-access data storage medium, which may be either flexible (diskette) or hard (fixed disk).

diskette. A flexible magnetic disk enclosed in a protective container.

diskette drive. The mechanism used to seek, read, and write data on diskettes.

display field. (1) An area in the display buffer that contains a set of characters that can be manipulated or operated upon as a unit. (2) A group of consecutive characters (in the buffer) that starts with an attribute character (defining the characteristics of the field) and contains one or more alphanumeric characters. The field continues to, but does not include, the next attribute character.

display frame. (1) In computer graphics, an area in storage in which a display image can be recorded. (2) In computer micrographics, an area on a microform in which a display image can be recorded.

display station. An input/output device containing a display screen and an attached keyboard that allows a user to send information to or receive information from the system.

distributed function terminal (DFT). A programmable terminal that can perform operations previously performed by the control unit. These terminals can interpret the 3270 data stream themselves. Examples are the IBM 3270 Personal Computer and the 3290 Information Panel.

distributed function terminal (DFT) mode. A host-interactive mode that enables an IBM 3270 Information Display System customized in this mode to run as many as four host sessions. The sessions can emulate a 3178, 3179, 3278 Model 2, or 3279 Model S2A.

downstream. (1) In the direction of data flow or toward the destination of transmission. (2) From the processor toward an attached unit or end user. (3) Contrast with *upstream*.

downstream load (DSL). The capability of a distributed function terminal to receive its control program from the control unit to which it is attached. A diskette containing the terminal's control program is loaded into the control unit.

drop. In the IBM Cabling System, a cable that runs from a faceplate to the distribution panel in a wiring closet.

duplex. Pertaining to communication in which data can be sent and received at the same time. Synonymous with *full duplex*.

E

EIA communication adapter. A communication adapter conforming to EIA standards that can combine and send information on two lines at speeds up to 19.2 kbps.

emulate. (1) To imitate one system with another, primarily by hardware, so that the imitating system accepts the same data, executes the same computer programs, and achieves the same results as the imitated computer system.

emulation. (1) The imitation of all or part of one system by another, primarily by hardware, so that the imitating system accepts the same data, executes the same programs, and achieves the same results as the imitated computer system. (2) The use of programming techniques and special machine features to permit a computing system to execute programs written for another system. (3) Imitation; for example, imitation of a computer or device. (4) See *terminal emulation*. (5) Contrast with *simulation*.

encrypt. To scramble data or convert it, before transmission, to a secret code that masks the meaning of the data to any unauthorized recipient. Contrast with *decrypt*.

Erase All Unprotected (EAU) command. A 3270 data stream command that erases all unprotected fields and inserts nulls.

event. (1) An occurrence or happening. (2) An occurrence of significance to a task; for example the completion of an asynchronous operation, such as an input/output operation.

extended binary-coded decimal interchange code (EBCDIC). A coded character set of 256 eight-bit characters.

extended highlighting. (1) A function that provides blink, reverse video, and underscore for emphasizing fields or characters on devices supporting extended field attributes and character attributes. (2) An attribute type in the extended field attribute and character attribute. (3) An attribute passed between session partners in the Start Field Extended, Modify Field, and Set Attribute orders.

Glossary

F

fault domain. In IBM Token-Ring Network problem determination, the portion of a ring that is involved with an indicated error.

field. See *display field*.

file. A named set of records stored or processed as a unit.

fixed disk. A rigid magnetic disk used in a fixed disk drive.

fixed disk drive. A disk storage device that reads and writes on rigid magnetic disks.

flag. (1) An indicator or parameter that shows the setting of a switch. (2) Any of various types of indicators used for identification, for example, a wordmark. (3) A character that signals the occurrence of some condition, such as the end of a word. (4) Deprecated term for *mark*.

flow control. (1) In data communication, control of the data transfer rate. (2) In SNA, the process of managing the rate at which data traffic passes between components of the network. The purpose of flow control is to optimize the rate of flow of message units with minimum congestion in the network, that is, neither to overflow the buffers at the receiver or at intermediate routing nodes nor to leave the receiver waiting for more message units. (3) The methods used to control the flow of information across a network.

foreground logical terminal (LT). Synonym for *active logical terminal (LT)*.

frame. (1) The portion of a tape, on a line perpendicular to the reference edge, on which binary characters can be written or read simultaneously. Synonymous with *tape row*. (2) A housing for machine elements. (3) The hardware support structure, covers, and all electrical parts mounted therein that are packaged as one entity for shipping. (4) A formatted display. See *display frame*.

from diskette. The diskette that provides the data to be transferred.

from drive. The drive that provides the data to be transferred.

full duplex. Synonym for *duplex*.

G

gateway. (1) A functional unit that connects two computer networks of different network architectures.

Note: A gateway connects networks or systems of different architectures. A bridge interconnects networks or systems with the same or similar architectures.

generate. In 3174 central site customizing, to write a Control diskette containing the customizing data for a particular control unit. Also, to print a mailing address label and a diskette label for a particular control unit.

get. In 3174 central site customizing, to select the type of data you want, and its source, and store it in working copy.

H

half-duplex. In data communication, pertaining to transmission in only one direction at a time. Contrast with duplex.

hexadecimal. (1) Pertaining to a selection, choice, or condition that has 16 possible values or states. (2) Pertaining to a fixed-radix numeration system, with radix of 16. (3) Pertaining to a numbering system with base of 16; valid numbers use the digits 0 through 9 and characters A through F, where A represents 10 and F represents 15.

hexadecimal number. The 1-byte hexadecimal equivalent of an EBCDIC character.

host access method. The access method that controls communication with a domain.

host attachment. A mode of SNA communication in which the processor acts as a secondary SNA device.

host interface. Interface between a network and the host computer.

host logical unit (LU). An SNA logical unit (LU) located in a host processor, for example, an ACF/VTAM application program.

host node. (1) A node at which a host processor is located. (2) In SNA, a subarea node that contains a system services control point (SSCP); for example, a System/370 computer with OS/VS2 and ACF/TCAM.

host system. (1) A data processing system used to prepare programs and operating environments for use on another computer or controller. (2) The data processing system to which a network is connected and with which the system can communicate. (3) The controlling or highest-level system in a data communi-

cation configuration; for example, a System/38 is the host system for the work stations connected to it.

I

initial microcode load (IML). The action of loading the operational microcode.

input/output (I/O). (1) Pertaining to a device whose parts can perform an input process and an output process at the same time. (2) Pertaining to a functional unit or channel involved in an input process, output process, or both, concurrently or not, and to the data involved in such a process. (3) Pertaining to input, output, or both.

interface. (1) A shared boundary between two functional units, defined by functional characteristics, common physical interconnection characteristics, signal characteristics, and other characteristics as appropriate. (2) A shared boundary. An interface may be a hardware component to link two devices or a portion of storage or registers accessed by two or more computer programs. (3) Hardware, software, or both, that links systems, programs, or devices.

K

keyboard definition. A customizing procedure for defining a maximum of four modified keyboard layouts for modifiable keyboards only. Most characters, symbols, and functions can be relocated, duplicated, or deleted from almost any keyboard position.

L

leased line. Synonym for *nonswitched line*.

Library (LIB) disk. A diskette or fixed disk that contains customizing data for some or all of the control units in a network.

library member. A file located on a Library diskette that contains customizing information for a control unit in a network.

Limited Function Utility (LFU) diskette. Contains the microcode to run only a limited number of utilities. These are: Diagnostics, Copy Files, Encrypt/Decrypt Master Key, and Identify Customizing Keyboard. It is used mainly in networks that are under central site control.

line speed. (1) The rate at which data is transmitted from one point to another over a telecommunication line. (2) The number of binary digits that can be sent over a telecommunication line in 1 second, expressed in bits per second (bps).

link. The logical connection between nodes including the end-to-end link control procedures.

local. Pertaining to a device accessed directly without use of a telecommunication line. Synonym for *channel-attached*. Contrast with *remote*.

location. With reference to a 3174, a place within the 3174 chassis where a particular card or adapter is inserted.

logical terminal (LT). In MLT, one of five sessions available to share one display station.

logical unit (LU). In SNA, a port through which an end user accesses the SNA network in order to communicate with another end user and through which the end user accesses the functions provided by system services control points (SSCPs). An LU can support at least two sessions, one with an SSCP and one with another LU, and may be capable of supporting many sessions with other logical units.

M

main storage. Program-addressable storage from which instructions and other data can be loaded directly into registers for subsequent processing.

maintenance analysis procedure (MAP). A maintenance document that gives an IBM service representative a step-by-step procedure for tracing a symptom to the cause of a failure.

mark. A symbol or symbols that indicate the beginning or the end of a field, a word, an item of data or a set of data such as a file, record, or block.

memory. Program-addressable storage from which instructions and other data can be loaded directly into registers for subsequent execution or processing. Synonymous with *main storage*.

microcode. (1) One or more microinstructions. (2) A code, representing the instructions of an instruction set, that is implemented in a part of storage that is not program-addressable. (3) To design, write, and also to test one or more microinstructions.

microcode upgrade diskette. An upgraded version of a Control diskette that includes new function, such as the ability to handle a new type of display station.

modem (modulator/demodulator). A device that converts digital data from a computer to an analog signal that can be transmitted on a telecommunication line, and converts the analog signal received to data for the computer.

multiple logical terminal (MLT). In the 3174, a function that provides a CUT-attached, fixed-function display

Glossary

station with the ability to interact with as many as five host sessions. Each session is processed as though it were a separate display station.

N

native mode. A 3179 or 3180 operational mode that uses the full capabilities of those models' display and keyboard.

NetView. A comprehensive network management product that is the basis for central control of both systems for network operations. It supersedes NCCF, NPDA, NLDM, and NPM.

network. (1) An arrangement of nodes and connecting branches. Connections are made between data stations. (2) A configuration of data processing devices and software connected for information interchange.

Network Site Control Unit. Any SNA-configured control unit in a network that is also configured to support central site change management.

nonswitched line. (1) A connection between systems or devices that does not have to be made by dialing. Contrast with *switched line*. (2) A telecommunication line on which connections do not have to be established by dialing. Synonymous with *leased line*.

O

open. (1) To make an adapter ready for use. (2) A break in an electrical circuit.

operator information area (OIA). The area below the line near the bottom of the display area where graphics and alphanumeric characters are displayed to define the status of the terminal or the system to the operator.

original equipment manufacturer (OEM). A manufacturer of equipment that may be marketed by another manufacturer.

P

parallel. (1) Pertaining to a process in which all events occur within the same interval of time, each handled by a separate but similar functional unit; for example, the parallel transmission of the bits of a computer word along the lines of an internal bus. (2) Pertaining to concurrent or simultaneous operation of two or more devices or to concurrent performance of two or more activities in a single device. (3) Pertaining to concurrent or simultaneous occurrence of two or more related activities in multiple devices or channels. (4) Pertaining to the simultaneity of two or more processes. (5) Pertaining to the simultaneous processing

of the individual parts of a whole, such as the bits of a character and the characters of a word, using separate facilities for the various parts. (6) Contrast with *serial*.

parameter. (1) A variable that is given a constant value for a specified application and that may denote the application. (2) An item in a menu for which the user specifies a value or for which the system provides a value when the menu is interpreted. (3) Data passed between programs or procedures.

parity. (1) A transmission error-checking scheme in which an extra bit is added to some unit of data, usually a byte, in order to make the total number of one bits even or odd. For the AEA feature, odd, even, mark, space, or no-parity coding is supported. No-parity means that no parity bit is sent or expected. Mark and space mean that the parity position is always set to one or zero, respectively, and that received parity is not checked. (2) The state of being either even-numbered or odd-numbered.

path. In a network, a route between any two nodes.

physical unit (PU). In SNA, the component that manages and monitors the resources (such as attached links and adjacent link stations) of a node, as requested by an SSCP through an SSCP-SSCP session.

polling. (1) On a multipoint connection or a point-to-point connection, the process whereby data stations are invited one at a time to transmit. (2) Interrogation of devices for such purposes as to avoid contention, to determine operational status, or to determine readiness to send or receive data.

port. (1) An access point for data entry or exit. (2) A connector on a device to which cables for other devices such as display stations and printers are attached.

primary logical unit (PLU). In SNA, the logical unit (LU) that contains the primary half-session for a particular LU-LU session. Contrast with *secondary logical unit*.

printer authorization matrix. A matrix stored in the control unit that establishes printer assignment and classification.

program access (PA) key. On a display device keyboard, a key that produces a call to a program that performs display operations. See also *program function (PF) key*.

program attention key. On a display device keyboard, a key that produces an interruption to solicit program action. See also *program access (PA) key* and *program function (PF) key*.

program function (PF) key. On a display device keyboard, a key that passes a signal to a program to call for a particular display operation. See also *program access (PA) key*.

programmable symbols (PS). Customer-defined symbols. There are a maximum of 190 symbols in a programmed symbol set.

programmed symbol set (PSS). A set of fonts that can be system-defined or defined by the user and to which a code can be assigned.

programmed symbols (PS). In the 3270 Information Display System, an optional feature that stores up to six user-definable, program-loadable character sets of 190 characters each in terminal read/write storage for display or printing by the terminal.

protocol. (1) A set of semantic and syntactic rules that determine the behavior of functional units in achieving communication. (2) In SNA, the meanings of and the sequencing rules for requests and responses used for managing the network, transferring data, and synchronizing the states of network components.

put. In 3174 central site customizing, to store data from the working copy into a library member.

R

remote. Pertaining to a system, program, or device that is accessed through a telecommunication line.

request for price quotation (RPQ). An alteration or addition to the functional capabilities that the control unit provides.

response field. On a display device, a specified area on the display space where the user can enter, modify, or erase response data.

Response Time Monitor (RTM). A network management tool that measures and records the transaction times of inbound host attention (AID) operations from display stations that communicate with the host.

ring interface adapter. A device that assumes the basic data transmission functions of node, such as frame recognition, address decoding, error checking, buffering of frames, fault detection, and, in Token-Ring Networks, token generation.

ring network. A network configuration where a series of attaching devices are connected by unidirectional transmission links to form a closed path.

S

secondary logical unit (SLU). In SNA, the logical unit (LU) that contains the secondary half-session for a particular LU-LU session. Contrast with *primary logical unit*.

segment. A section of cable between components or

devices on the network. A segment may consist of a single patch cable, multiple patch cables connected, or a combination of building cable and patch cables connected.

serial. (1) Pertaining to a process in which all events occur one after the other; for example, serial transmission of the bits of a character according to V24 CCITT protocol. (2) Pertaining to the sequential or consecutive occurrence of two or more related activities in a single device or channel. (3) Pertaining to the sequential processing of the individual parts of a whole, such as the bits of a character or the characters of a word, using the same facilities for successive parts. (4) Contrast with *parallel*.

service access point. A logical point made available by an adapter where information can be received and transmitted. A single SAP can have many links terminating in it.

session. (1) In network architecture, an association of facilities necessary for establishing, maintaining, and releasing connections for communication between stations. (2) In MLT, synonymous with logical terminal (LT). (3) In SNA, a logical connection between two network addressable units that can be activated, tailored to provide various protocols, and deactivated as requested.

session limit. In 3174, the total number of logical terminals or defined AEA default destinations for an AEA port set.

simulate. (1) To represent certain features of the behavior of a physical or abstract system by the behavior of another system; for example, to represent a physical phenomenon by means of operations performed by a computer or to represent the operations of a computer by those of another computer. (2) To imitate one system with another, primarily by software, so that the imitating system accepts the same data, executes the same computer programs, and achieves the same results as the imitated system. (3) Contrast with *emulate*.

simulation. (1) The representation of selected characteristics of the behavior of one physical or abstract system by another system. In a digital computer system, simulation is done by software; for example, (a) the representation of physical phenomena by means of operations performed by a computer system, and (b) the representation of operations of a computer system by those of another computer system. (2) Contrast with *emulation*.

SNA character string (SCS). A character string composed of EBCDIC controls, optionally intermixed with end-user data, that is carried within a request/response unit.

Glossary

sort. In 3174 central site customizing, to arrange a list of library members according to date, name, or micro-code level.

staging adapter. (1) An addition to a System/370 Model 158 or 168 Integrated Storage Control (ISC) feature that enables the integrated storage control to operate in a 3850 Mass Storage System. (2) An IBM 3850 Model 3 Storage Control, which is a 3830 Model 2 Storage Control that has been modified to operate in a 3850 Mass Storage System.

station. (1) An input or output point of a system that uses telecommunication facilities; for example, one or more systems, computers, terminals, devices, and associated programs at a particular location that can send or receive data over a telecommunication line. (2) A location in a device at which an operation is performed, for example, a read station. (3) In SNA, a link station.

stop bit. Synonym for *stop signal*.

stop signal. In start-stop transmission, a signal at the end of a character that prepares the receiving device for reception of a subsequent character. Synonymous with *stop bit*.

storage. A unit into which recorded text can be entered, in which it can be retained and processed, and from which it can be retrieved. See also *memory*.

structured field. A data stream format that permits variable-length data and controls to be parsed into its components without having to scan every byte.

subsystem. A secondary or subordinate system, or programming support, usually capable of operating independently of or asynchronously with a controlling system. The 3174 and its attached terminals are an example of a subsystem.

switched line. A telecommunication line in which the connection is established by dialing. Contrast with *nonswitched line*.

synchronous. (1) Pertaining to two or more processes that depend on the occurrences of a specific event, such as common timing signal. (2) Occurring with a regular or predictable time relationship.

Synchronous Data Link Control (SDLC). A discipline conforming to subsets of the Advance Data Communication Control Procedures (ADCCP) of the American National Standards Institute (ANSI) and High-level Data Link Control (HDLC) of the International Organization for Standardization, for managing synchronous, code-transparent, serial-by-bit information transfer over a link connection. Transmission exchanges may be duplex or half-duplex over switched or nonswitched links. The configuration of the link connection may be

point-to-point, multipoint, or loop. See also *binary synchronous communication (BSC)*.

system configuration. A process that specifies the devices and programs that form a particular data processing system.

system services control point (SSCP). In SNA, the focal point within an SNA network for managing the configuration, coordinating network operator and problem determination requests, and providing directory support and other session services for end users of the network. Multiple SSCPs, cooperating as peers, can divide the network into domains of control, with each SSCP having a hierarchical control relationship to the physical units and logical units within its domain.

Systems Network Architecture (SNA). The description of the logical structure, formats, protocols, and operational sequences for transmitting information units through, and controlling the configuration and operation of, networks.

T

telecommunication-attached. Pertaining to the attachment of devices by teleprocessing lines to a host processor. Synonym for *remote*. Contrast with *channel-attached*.

telecommunication control unit. See *communication control unit*.

terminal. In data communication, a display station or printer capable of sending or receiving information.

terminal adapter (TA). An adapter that provides control for a maximum of 32 terminals; each BNC connector (four in all) on the terminal adapter can control either one terminal that is directly attached or as many as eight terminals that are attached through a terminal multiplexer adapter (located in the 3174) or a 3299 Terminal Multiplexer (located outside the 3174).

terminal emulation. The capability of a microcomputer, personal computer, 3270 CUT mode display station, 3270 printer, ASCII display station, or ASCII printer to operate as if it were a particular type of terminal linked to a processing unit and to access data.

terminal multiplexer. A device, such as the 3299 Terminal Multiplexer, for interleaving the signals for many devices onto a single coaxial cable.

terminal multiplexer adapter (TMA). This adapter is connected to the terminal adapter in the 3174 and provides control for a maximum of eight terminals.

terminal node. (1) In a hierarchical data base, a node that has no subordinate records or segments. (2) In SNA products, a peripheral node that is not user-

programmable and has less processing capability than a cluster controller node. Examples are nodes consisting of the IBM 3277 Data Station, 3767 Communication Terminal, 3614 Consumer Transaction Facility, and 3624 Consumer Transaction Facility.

to diskette. The diskette that receives the transferred data.

to drive. The drive that receives the transferred data.

token. In a local area network, the symbol of authority passed among data stations to indicate the station temporarily in control of the transmission medium.

Note: A token is a particular message or bit pattern that signifies permission to transmit.

Token-Ring Network. (1) A ring network that allows unidirectional data transmission between data stations by a token-passing procedure over one transmission medium so that the transmitted data returns to the transmitting station. (2) A network that uses a ring topology, in which tokens are passed in a circuit from node to node. A node that is ready to send can capture the token and insert data for transmission.

transmission control unit (TCU). A communication control unit whose operations are controlled solely by programmed instructions from the computing system to which the unit is attached. No program is stored or executed in the unit, for example, the IBM 2702 and 2703 Transmission Controls. Contrast with *communication controller*. Synonymous with *telecommunication control unit*.

transmitter. See *universal receiver-transmitter*.

Type. In the 3174 Subsystem Control Unit, the identifying number of a card. For example, 9150 is the type number of the terminal adapter in the 3174.

U

universal receiver-transmitter. A circuit used in asynchronous, synchronous, or synchronous/asynchronous data communication applications to provide all the necessary logic to recover data in a serial-in parallel-out fashion and to transmit data in a parallel-in serial-out fashion. It is usually duplex; that is, it can transmit and receive simultaneously with the option to handle various data word lengths.

update. In 3174 central site customizing, to tailor a library member's customizing data, in working copy, and put it back to the library diskette.

upgrade. In 3174 central site customizing, to select a library member and upgrade its data to the microcode level of the Central Site Customizing Procedure diskette.

upstream. (1) In the direction opposite to data flow or toward the source of transmission. (2) Toward the processor from an attached unit or end user. (3) Contrast with *downstream*.

Utility (UTL) disk. A diskette or fixed disk that contains the microcode necessary to run various utilities, for example, to copy portions of a diskette for a backup diskette.

Utility (UTL) diskette. A diskette that contains the microcode necessary to run various utilities, for example, to copy portions of a diskette for a backup diskette.

V

V.35 communication adapter. A communication adapter that can combine and send information on one line at speeds up to 64 kbps, and conforms to the CCITT V.35 standard.

W

workstation. An input/output device that allows transmission of data or reception of data as needed to perform a job.

wraparound. The continuation of an operation (for example, a read operation or a cursor movement operation) from the last character position in a buffer to the first character position in the buffer.

write. To make a permanent or transient recording of data in a storage device or on a data medium.

write control character (WCC). A character used in conjunction with a Write command to specify that a particular operation, or combination of operations, is to be performed at a display station or printer.

X

X.21. In data communication, a recommendation of the International Telegraph and Telephone Consultative Committee (CCITT) that defines the interface between data terminal equipment and public data networks for digital leases and circuit switched synchronous services.

X.21 communication adapter. A communication adapter that can combine and send information on one line at speeds up to 64 kbps, and that conforms to CCITT X.21 standards.

X.25. In data communication, a recommendation of the CCITT that defines the interface between data terminal equipment and packet switching networks.

3

3270 data stream. (1) The commands, control codes, orders, attributes, and data or structured fields for 3270 devices, that are transmitted inbound to an application program or outbound to a terminal. (2) Data being transferred from or to an allocated primary or tertiary device, or to the host system, as a continuous stream of

data and 3270 Information Display System control elements in character form.

3270 emulation. The use of a program that allows a device or system such as a personal computer or a System/38 to operate in conjunction with a host system as if it were a 3270-series display station or control unit.

Index

A

- access to direct and dial keys 3-42
- ACF/NCP 3-32
- ACF/VTAME 3-32
- additional extension mode key definition for personal computers (168) 3-29
- additional storage requirements
 - asynchronous emulation adapter (AEA) 3-7, 8-5
 - central site change management (CSCM) 3-7
 - multiple logical terminals (MLT) 3-7
 - token-ring 3270 gateway 3-7
- address
 - calls, DCE 3-42
 - control unit (104) 3-12
 - data terminal equipment 6-10
 - Gateway, Token-Ring Network (900) 9-3
 - hexadecimal polling 3-12
 - host DTE 6-8, 6-10
 - polling 3-12
 - port (118) 3-20
 - ring assignment (940) 9-4
 - Token-Ring Network of gateway (107) 3-16
 - Token-Ring Network, of 3174 (106) 3-15
 - universal 9-4
 - upper limit (105) 3-14
 - 3174 DTE 6-9
- AEA 8-1
 - See also* Asynchronous Emulation Adapter (AEA)
 - Port Set panel 8-29
 - Port to Port Set Map panel 8-29
- AEA configuration questions 8-27
 - 700 configure the AEA feature 8-27
 - 701 password for ASCII display stations on switched lines 8-27
- AEA Configure
 - AEA completion panel 13-65
 - AEA Configure panel, entering responses 13-59
 - AEA Default Destination panel, entering responses 13-64
 - AEA Port Set panel, entering responses 13-60
 - AEA Port to Port Set Map panel, entering responses 13-61
 - AEA Station Set panel(s), entering responses 13-62
 - description of 1-12, 13-56
 - PF keys 13-56
 - procedure 13-56
 - procedure, warning 13-65
 - reconfiguring 13-56
 - saving the data 13-65
 - selecting 13-58
- AEA station set questions 8-32
 - 721 station set name 8-32
 - 722 station type 8-32
- AEA station set questions (*continued*)
 - 723 port set name 8-33
 - 725 host connection menu option 8-33
 - 731 flow control type 8-33
 - 732 XON/XOFF transmission resumption trigger 8-34
 - 733 line speed 8-35
 - 734 line speed, ASCII host upper limit 8-35
 - 735 parity 8-36
 - 736 stop bits 8-36
 - 737 maximum modem line speed 8-36
 - 741 switched disconnect timeout 8-37
 - 742 inactivity timeout 8-37
 - 743 prompt for universal/specific keyboard map 8-38
 - 751 data stream supported by the ASCII host 8-38
 - 752 ASCII host phone number 8-38
 - 761 auto XON/XOFF 8-40
 - 762 wraparound option 8-40
 - 763 new line option 8-41
 - 764 margin bell 8-41
 - 771 automatic line feed for cursor control 8-41
 - 772 carriage return/carriage return - line feed selection 8-42
 - 773 automatic new line for cursor control 8-42
 - 774 scrolling 8-42
 - 775 line turnaround character 8-42
 - 781 attached printer prompt 8-42
 - 782 use of form feed 8-43
 - 783 page length 8-43
- AEA worksheets, completing 8-27
 - AEA configure 8-27
 - AEA default destination 8-43
 - AEA port set 8-27
 - AEA port to port set map 8-28
 - AEA station set 8-30
- aid, file transfer 3-24
- alarm, background 3-24
- alert function (220) 3-34
- alert, operator-generated 3-34
- Alt 1 IML 12-3
 - deselecting a source 18-3
 - from a diskette 12-5
 - from a fixed disk 12-5
 - inserting diskettes 12-6
 - model 1L 12-10
 - overview 12-3
 - remote models 12-7
 - selecting a source 18-3
 - warning 12-7, 12-10
- alternate configuration 3-10
- alternate keyboard selection base (132) 3-25
- alternate keyboard selection (132)
 - layouts of B-3

Index

APL keyboard
 response for 3-26
 restrictions 11-11
APL2, warning 11-5, 13-46
ASCII
 attached printer prompt (781) 8-42
 Attachment Diagram worksheet 20-19
 data stream supported by the host 8-38
 display stations on switched lines, password (701) 8-27
 display stations supported 8-7
 display stations with attached printers 8-42
 filling out attachment diagram 8-14
 host phone number (752) 8-38
 host station using
 IBM 3101 data stream 8-41
 using DECVT100 data stream 8-40
 line speed, host upper limit 8-35
 numbering the attachment diagrams 8-25
 station type 8-32
 terminal emulation 8-4
ASCII, individual port assignment 3-20
assignment
 individual port (116) 3-20
 of ports 4-3
 port (117) 3-20
assistance data, product (099) 3-10
Asynchronous Emulation Adapter (AEA) 8-1
 See also AEA
 ASCII Attachment Diagram worksheet 20-19
 ASCII terminal emulation 8-4
 completing AEA Configure 13-65
 completing the ASCII Attachment Diagram 8-14
 completing the 3270 Attachment Diagram 8-8
 Configure worksheet 20-20
 connection menu 8-3
 considerations 8-5
 default destination 8-3
 Default Destination worksheet 20-24
 description of 8-6
 display stations supported 8-7
 embedded character substitution 8-39
 information needed to assign devices to sets 8-6
 MLT considerations 8-5
 modem type 8-28
 name, port set 8-27
 numbering station sets 8-25
 planning for 8-1
 planning tasks 8-6
 port assignment considerations 4-5
 port set 8-4
 Port Set worksheet 20-21
 Port to Port Set Map worksheet 20-22
 port type 8-28
 session limit 8-27
 station 8-4
 station set 8-4
 Station Set worksheet 20-23

Asynchronous Emulation Adapter (AEA) (*continued*)
 station type questions, list of 8-31
 storage considerations 8-5
 storage requirements 3-7
 terminal type menu 8-3
 terminology 8-3
 3270 Attachment Diagram worksheet 20-18
 3270 terminal emulation 8-4
attached printer prompt (781) 8-42
attachment diagram
 ASCII, filling out 8-14
 numbering 8-25
 3270, filling out 8-8
attachment, host (101) 3-11
attention delay value (223) 3-36
attribute select keyboard (166) 3-29, B-8
Austrian/German, language code 3-21
auto XON/XOFF (761) 8-40
automatic assignment of ports 4-3
automatic form feed 3-31
automatic line feed for cursor control (771) 8-41
automatic new line for cursor control (773) 8-42
AZERTY keyboard layout 19-3

B

background alarm 3-24
base keyboards
 8K0808 3-25, B-3
 8K0932 3-25
 8K0932 (model C-4) B-3
 8K1038 3-25
 8K1038 (model C-3) B-3
 8K1158 3-25, B-4
Belgian, language code 3-21
bell, margin (764) 8-41
between bracket sharing (213) 3-33
bits, stop (736) 8-36
boundary values, RTM 5-7
Brazilian, language code 3-21
breached security 17-3
British Telecom 6-5
BSC (binary synchronous communication)
 as host attachment 3-11
 converting polling address 3-12
 enhanced communication (176) 3-32
 special controlled request-to-send 3-39
 worksheet 20-4
buffer, display 3-32
burst size, channel
 information on 3-35
 question for (225) 3-36

C

calls
 address 3-42
 direct 3-42

- Canadian (bilingual), language code 3-21
- carriage return/carriage return - line feed selection (772) 8-42
- CECP, warning 11-5
- Central Site Change Management (CSCM)
 - completing the worksheet 7-4
 - description of 7-3
 - host configuration 7-3
 - planning 7-1
 - storage requirements 3-7
- Central Site Control Unit 7-4
- Central Site Customizing, description of 1-9
- changing
 - Encrypt/Decrypt master key value 17-8
 - X.25 options 6-15
- channel burst size
 - information on 3-35
 - question for (225) 3-36
- character
 - set, keyboard (121) 3-20
 - set, magnetic (141) 3-28
 - substitution, embedded 8-39
- character string, translated 8-40
- CICS/VS 3-32
- CID (connection identifier password) 6-14
- circuit type (401) 6-5
- class negotiation, throughput class (440) 6-12
- clear key, dual-function 3-23
- clicker option 3-23
- closed user group (441) 6-13
- COMM key, X.25 6-7
- command retry (222) 3-34
- command, LOCATE 13-29
- Common SNA panel 7-4
 - entering responses 13-18
- Common SNA worksheet 20-26
- communicate key, local 3-41
- communication data, security 17-3
- communication, BSC enhanced 3-32
- compatibility requirements, display 3-4
- completing
 - AEA Configure 13-65
 - Configure procedure 13-24
 - Customize Control Disk 13-67
 - Merge RPQs 13-39
 - Modify Keyboards 13-55
 - PAM definition 13-30
- compressed program symbols (165) 3-29
- configuration completion, warning 13-8, 13-25, 13-30, 13-39, 13-55, 13-65, 13-66
- configuration level 15-6, 16-4
- configuration level, MLT (110) 3-17
- configuration planning
 - overview 3-5
 - steps 3-5
- configuration questions 3-10
 - 099 product assistance data 3-10
 - 100 model designation 3-10
- configuration questions (*continued*)
 - 101 host attachments 3-11
 - 104 control unit address 3-12
 - 105 upper limit address 3-14
 - 106 Token-Ring Network address of the 3174 3-15
 - 107 Token-Ring Network address of gateway 3-16
 - 108 unique machine identifier 3-16
 - 110 MLT configuration level 3-17
 - 116 individual port assignment 3-20
 - 117: port assignment 3-20
 - 118 port address 3-20
 - 121 keyboard language and character set 3-20
 - 123 country extended code page (CECP) support 3-22
 - 125 miscellaneous feature options 3-22
 - 127 response time monitor definition 5-3
 - 127 Response Time Monitor (RTM) definition 3-24
 - 128 RTM boundaries and interface 3-25
 - 132 alternate base keyboard selection 3-25
 - 136 modifiable keyboards: standard layouts 3-26
 - 137 modifiable keyboards: modified layouts 3-27
 - 138 modifiable keypads: standard layouts 3-28
 - 141 magnetic character set 3-28
 - 165 compressed program symbols 3-29
 - 166 attribute select keyboard 3-29
 - 168 additional extension mode key definition (personal computers) 3-29
 - 173 3179G options 3-30
 - 173 3290 options 3-30
 - 175 3179G password 3-32
 - 175 3290 password 3-32
 - 176 BSC enhanced communications 3-32
 - 178 7232 dual control unit terminal multiplexer switching 3-33
 - 213 between bracket sharing 3-33
 - 215 physical unit identification 3-33
 - 220 alert function 3-34
 - 222 command retry 3-34
 - 223 attention delay value 3-36
 - 224 mode of data transfer 3-36
 - 225 channel burst size 3-36
 - 310 connect data set to line operation 3-37
 - 313 NRZ or NRZI encoding 3-37
 - 317 telecommunication facilities 3-38
 - 318 full- or half-speed transmission 3-39
 - 332 X.25 options 3-39, 6-3
 - 340 request-to-send control options 3-39
 - 360 X.21 switched retry 3-40
 - 361 X.21 switched retry timing 3-40
 - 362 X.21 switched options 3-41
 - 365 X.21 data transfer delay 3-42
 - 367 X.21 switched short-hold mode 3-43
 - 368 X.21 switched short-hold mode dial number 3-43
 - 370 maximum inbound I-frame size 3-43
 - 380 maximum receive (outbound) I-frame size 3-44
 - 381 Token-Ring network maximum in 3-44
 - 382 maximum transmission I-frame size 3-45

Index

configuration questions (*continued*)

- 383 Token-Ring network maximum out 3-45
- 400 network type 6-5
- 401 circuit type 6-5
- 402 logical channel identifier 6-5
- 402 logical link control 6-6
- 409 X.25 keyboard support options 6-6
- 420 incoming call options 6-7
- 421 outgoing call options 6-9
- 423 host DTE address 6-10
- 424 3174 DTE address 6-10
- 430 negotiate packet size 6-10
- 431 packet sequence numbering 6-11
- 432 negotiated window size 6-11
- 433 K-maximum out 6-11
- 434 nonstandard default packet size 6-11
- 435 nonstandard default window size 6-12
- 440 throughput class negotiation 6-12
- 441 closed user group 6-13
- 442 recognized private operating agency 6-13
- 450 link level transmit timeout 6-13
- 451 number of retries 6-14
- 452 connection identifier password 6-14
- 500 CSCM unique 7-4
- 501 network ID (NETID) 7-5
- 502 logical unit name (LUNAME) 7-5
- 700 configure the AEA feature 8-27
- 701 password for ASCII display stations on switched lines 8-27
- 721 station set name 8-32
- 723 port set name 8-33
- 725 host connection menu option 8-33
- 731 flow control type 8-33
- 732 XON/XOFF transmission resumption trigger 8-34
- 733 line speed 8-35
- 734 line speed, ASCII host upper limit 8-35
- 735 parity 8-36
- 736 stop bits 8-36
- 737 maximum modem line speed 8-36
- 741 switched disconnect timeout 8-37
- 742 inactivity timeout 8-37
- 743 prompt for universal/specific keyboard map 8-38
- 751 data stream supported by the ASCII host 8-38
- 752 ASCII host phone number 8-38
- 761 auto XON/XOFF 8-40
- 762 wraparound option 8-40
- 763 new line option 8-41
- 764 margin bell 8-41
- 771 automatic line feed for cursor control 8-41
- 772 carriage retron/carriage return - line feed selection 8-42
- 772 station type 8-32
- 773 automatic new line for cursor control 8-42
- 774 scrolling 8-42
- 775 line turnaround character 8-42
- 781 attached printer prompt 8-42

configuration questions (*continued*)

- 782 use of form feed 8-43
- 783 page length 8-43
- 900 Token-Ring Network address for the Gateway 9-3
- 905 ring error monitor 9-3
- 908 link subsystem name 9-4
- 940 ring address assignment 9-4
- 941 ring transmission definition 9-5
- Configuration Questions Summary worksheet 20-32
- configuration questions summary, description of 2-5
- configuration responses
 - altered while copying 15-8
 - copying 15-9
- configuration worksheets 20-3
- configuration worksheets, description of 2-5
- configuration, alternate 3-10
- Configure
 - Common SNA panel 13-18
 - completing 13-24
 - completion panel 13-24
 - description of 1-11, 13-9
 - Host panel 13-14
 - Model/Attach panel 13-13
 - panel flow 13-9
 - PF keys 13-10
 - procedure 13-10
 - procedure, warning 13-24
 - reconfiguring 13-9
 - selecting 13-12
 - Token-Ring Gateway panel 13-15
 - 117: Port Assignment panel 13-19
 - 128: RTM panel
 - version A 13-21
 - version B 13-22
 - 332: X.25 Options panel 13-23
 - 940: Ring Address Assignment panel 13-16
 - 941: Ring Transmission Definition panel 13-17
- configure the AEA feature (700) 8-27
- connect data set to line operation (310) 3-37
- connection identifier 6-8, 6-9
- connection identifier password (452) 6-14
- connection menu 8-3
- considerations
 - AEA 8-5
 - MLT 3-19
 - port assignment 4-5
- Control disk
 - copying 15-7
 - description of 1-5
- control unit address(104) 3-12
- control unit ID (CID) 17-4
- control unit models, diagram of
 - 1L, 1R, 2R, and 3R 12-4
 - 51R, 52R, and 53R 12-4
 - 81R and 82R 12-5
- controlled request-to-send 3-39

- control, logical link (402) 6-6
- Converged Typewriter keyboard (PA3), warning 13-42
- Copy Files option, description of 1-8
- copy format controls, enable local copy 3-31
- Copy procedure
 - altering configuration responses 15-8
 - configuration responses 15-9
 - Control disk 15-7
 - Copy Customizing Data 15-9
 - defining the modified responses 15-15
 - description of 15-3
 - drive choices 15-4
 - DSL disk 15-7
 - from a fixed disk 15-5
 - Full Copy 15-7
 - Library disk 15-7
 - Limited Function Utility disk 15-7
 - Menu panel 15-3, 15-12
 - Modified Keyboards 15-10
 - Modify and Copy 15-8
 - Modify and Copy panel 15-15
 - multiple times 15-16
 - PAM 15-9
 - Patch(es) 15-10
 - PF keys 15-11
 - procedure for all types of 15-11
 - RPQs 15-10
 - selecting a Copy option 15-12
 - selecting from Master Menu 15-11
 - selecting, fixed disk subdirectory 15-13
 - subdirectories on a fixed disk 15-4
 - Subdirectory Selection panel 15-5
 - to a fixed disk 15-4
 - Utility disk 15-7
 - verify drives 15-13
 - warning 15-5
- copying from one key to another 11-15
- correcting errors A-3
- country extended code page (CECP) support (123) 3-22
 - languages supported 3-21
 - warning 3-22, 13-46
- CSCM configuration questions 7-4
 - 500 CSCM unique 7-4
 - 501 network ID (NETID) 7-5
 - 502 logical unit name (LUNAME) 7-5
- CSCM unique (500) 7-4
- CUG (closed user group) 6-13
- cursor control
 - automatic line feed (771) 8-41
 - automatic new line (773) 8-42
- customization data, management of 2-6
- Customize Control Disk procedure
 - AEA Configure 13-56
 - AEA Configure panel 13-59
 - AEA Default Destination panel 13-64
 - AEA Port Set panel 13-60
 - AEA Port to Port Set Map panel 13-61
- Customize Control Disk procedure (*continued*)
 - AEA Station Set panel(s) 13-62
 - Common SNA panel 13-18
 - completion 13-67
 - Configure 13-9
 - Define the PAM 13-26
 - description of 13-3
 - error correction procedure A-7
 - errors panel A-7
 - Host panel 13-14
 - interutility checking A-7
 - interutility checking, PF keys A-3
 - menu panel 13-8
 - Merging RPQs 13-31
 - Model/Attach panel 13-13
 - Modify Keyboards 13-41
 - PAM Definition panel 13-29
 - PF keys 13-5
 - procedure 13-6
 - reconfiguring 13-9
 - redefining 13-26
 - RPQ Merge panel 13-33
 - RPQ Utility panel 13-31
 - select procedure 13-8
 - selecting 13-6
 - Token-Ring Gateway panel 13-15
 - verify drives 13-7
 - warning 13-8, 13-25, 13-30, 13-39, 13-55, 13-66
 - 117: Port Assignment panel 13-19
 - 128: RTM panel
 - version A 13-21
 - version B 13-22
 - 940: Ring Address Assignment panel 13-16
 - 941: Ring Transmission Definition panel 13-17
- Customize the Control Disk
 - Menu options
 - AEA Configure 1-12
 - Configure 1-11
 - Define PAM (printer authorization matrix) 1-11
 - Merge RPQs 1-12
 - Modify Keyboards 1-12
 - Menu, description of 1-11
 - option, description of 1-8
- customizing
 - Control disk 1-6, 13-3
 - correcting invalid responses 13-4
 - Customize Control Disk Menu options 1-11
 - description of 1-4, 13-3
 - entering responses 13-3
 - introduction to 1-1
 - Master Menu options 1-8
 - panel description 1-13
 - planning 3-3
 - planning for 3174 1-4
 - planning steps 3-5
 - printing a local copy 13-3
 - sample panel 1-13
 - things needed before 13-5

Index

- Customizing Data, copy 15-9
- customizing display stations 1-7
- Customizing Errors Panel A-7
- customizing keyboard
 - default keyboard 19-3
 - identifying 19-4
 - panel for identifying 19-5
 - selecting 19-4
 - when to identify 19-3
 - which ones to identify 19-3
- customizing, warning 13-8, 13-25, 13-30, 13-39, 13-55, 13-66
- CUT port assignment considerations 4-5
- Cyrillic, language code 3-21

D

- Danish, language code 3-21
- Data Entry keyboard, response for 3-26
- data entry keypad, response for 3-28
- data loss, warning 13-8
- data management 18-3
- data security 17-3
- data stream
 - DECVT100, questions 8-40
 - IBM 3101 questions 8-41
- data stream supported by the ASCII host (751) 8-38
- data transfer delay, X.21 (365) 3-42
- data transfer modes 3-35
- data transfer (224) 3-36
- data, saving for
 - AEA Configure 13-65
 - configuration 13-24
 - customizing 13-67
 - Merge RPQs 13-39
 - Modify Keyboard 13-55
 - PAM 13-30
- DCE supported for
 - address calls 3-42
 - direct calls 3-42
- Decrypt
 - description of 17-3
- DECVT100 data stream, questions 8-40
 - 761 auto XON/XOFF 8-40
 - 762 wraparound option 8-40
 - 763 new line option 8-41
 - 764 margin bell 8-41
- default destination 8-3
- default IML, warning 15-5, 18-3
- default packet size, nonstandard (434) 6-11
- deferred keystroking (remote SNA) 3-24
- Define PAM (printer authorization matrix)
 - description of 1-11
- Define the PAM
 - completing 13-30
 - description of 13-26
 - LOCATE command 13-29
 - panels, entering responses 13-29
- Define the PAM (*continued*)
 - PF keys 13-26
 - procedure 13-26
 - selecting 13-28
- definition
 - additional extension-mode key (168) 3-29
 - Response Time Monitor (127) 5-3
 - ring transmission (941) 9-5
 - RTM (127) 3-24
- delay value, attention (223) 3-36
- delete subdirectory 18-4
- deleting key functions 11-14
- deleting subdirectories 18-9
 - procedure 18-9
- description of
 - Keyboard Changes Chart 11-8
- description of fields
 - Modify Keyboard Master panel 13-43
- deselect IML source 18-4
- deselecting an IML source
 - procedure 18-6
- designation, model (100) 3-10
- determining microcode levels 15-6, 16-4
- determining problems
 - error correction
 - Customize Control Disk A-7
 - Microcode Upgrade A-5
 - interutility checking A-3
 - panel informational areas A-4
 - utility checking panel A-4
- determining the MLT level 3-18
- devices, individual port assignment (116)
 - ASCII, DFT, 7232 devices 3-20
- DFT
 - See distributed function terminal
- Diagnostics, description of 1-9
- diagrams, attachment numbering 8-25
- dial key 3-42
- dial screen display 6-7
- direct calls, DCE 3-42
- direct key 3-42
- DISC key, X.25 6-6
- disconnect key 3-41
- disconnect timeout, switched (741) 8-37
- disconnect/local mode operation 6-7
- diskette
 - IMLing from 12-5
 - inserting 12-6
 - Merge DSL 14-6
- diskettes
 - for record-keeping 2-5
 - management of 2-6
 - pattern 3-4
- disks
 - Control 1-5
 - DSL (downstream load) 1-5
 - Encrypt/Decrypt 1-6
 - how to customize 1-6

- disks (*continued*)
 - kinds of 1-5
 - LFU (limited function utility) 1-5
 - RPQ (request for price quotation) 1-5
 - Utility 1-5
 - display buffer 3-32
 - display compatibility requirements 3-4
 - display stations
 - used for customizing 1-7
 - display stations supported by AEA 8-7
 - displaying the Encrypt/Decrypt verification pattern 17-11
 - displaying the Master Menu 12-3
 - menu panel 12-3
 - model 1L 12-10
 - overview 12-3
 - remote models 12-7
 - using a diskette 12-5
 - using a fixed disk 12-5
 - display, dial screen 6-7
 - distributed function terminal (DFT) 3-30
 - automatic form feed after local copy 3-31
 - automatic form feed before local copy 3-31
 - BSC enhanced communication (176) 3-32
 - enable local copy format controls 3-31
 - field intensity, 3290 3-31
 - individual port assignment 3-20
 - options (173) 3-30
 - port assignment considerations 4-5
 - update panel before allowing buffer change 3-32
 - DPKT (default packet size) 6-11
 - drive choices 15-4
 - for copy 15-4
 - drives, verify
 - Copy 15-13
 - Customize Control Disk 13-7
 - Encrypt/Decrypt 17-6, 17-7
 - Media Management 18-7, 18-10
 - Merge RPQs 13-36, 13-37
 - Microcode Upgrade 16-8
 - DSL Merge
 - after Microcode Upgrade 16-3
 - description of 14-3
 - multiple merges 14-9
 - panel 14-4
 - PF keys 14-5
 - procedure 14-5
 - select Merge/Delete 14-8
 - selecting 14-5
 - using a diskette 14-6
 - using a fixed disk 14-6
 - when to 14-3
 - DSL (downstream load) disk
 - copying 15-7
 - description of 1-5
 - DTE (data terminal equipment)
 - host address 6-8, 6-10
 - 3174 address 6-9, 6-10
 - dual-function clear key 3-23
 - DWND (default window size) 6-12
- ## E
- EBCDIC (World Trade), language code 3-21
 - embedded character substitution
 - Hayes 8-39
 - IBM 8-39
 - Micom 8-39
 - emulation
 - ASCII terminal 8-4
 - asynchronous considerations 8-5
 - asynchronous overview 8-6
 - asynchronous planning 8-1
 - asynchronous planning tasks 8-6
 - filling out AEA worksheets 8-27
 - filling out ASCII attachment diagram 8-14
 - numbering AEA attachment diagrams 8-25
 - 3270 attachment diagram, filling out 8-8
 - 3270 terminal 8-4
 - enable local copy format controls 3-31
 - encoding, NRZ or NRZI (313) 3-37
 - Encrypt/Decrypt
 - adapter 17-3
 - before the MKV is entered 17-4
 - control unit ID (CID) 17-4
 - description of 1-9, 17-3
 - diskette description 1-6
 - feature 17-3
 - filling in the panel 17-9
 - inserting the security key 17-8
 - master key value (MKV) 17-3
 - options 17-4
 - PF keys 17-5
 - procedure 17-5
 - display verification pattern 17-11
 - enter, initialize, change master key value 17-8
 - test Encrypt/Decrypt feature 17-15
 - verify master key value 17-13
 - security key 17-3
 - selecting 17-5
 - Utility panel 17-4
 - verification pattern (VP) 17-3
 - verify drives 17-6, 17-7
 - warning 17-8, 17-15
 - English (U.K.), language code 3-21
 - English (U.S.) ASCII, language code 3-21
 - English (U.S.) EBCDIC, language code 3-21
 - Enhanced Typewriter keyboard
 - Katakana worksheet 20-31
 - response for 3-26
 - U.S. worksheet 20-29
 - World Trade worksheet 20-30
 - entering customizing responses
 - AEA Configure panel 13-59
 - AEA Default Destination panel 13-64
 - AEA Port Set panel 13-60

Index

entering customizing responses (*continued*)

- AEA Port to Port Set Map panel 13-61
 - AEA Station Set panel(s) 13-62
 - Common SNA panel 13-18
 - Encrypt/Decrypt panel 17-9
 - Host panel 13-14
 - in general 13-3
 - Model/Attach panel 13-13
 - PAM panel(s) 13-29
 - Token-Ring Network Gateway panels 13-15
 - 117: Port Assignment panel 13-19
 - 128: RTM panel 13-21
 - 332: X.25 Options panel 13-23
- entering the Encrypt/Decrypt master key value 17-8
- erasure of customized data, warning 13-24, 13-65
- error correction A-3
- error monitor, ring (905) 9-3
- extended code page support 3-22
- extension key, X.21 switched 3-41
- extension mode key for PCs 3-29

F

- facilities, nonswitched 3-38
- facilities, telecommunication (317) 3-38
- facility
- negotiated packet size 6-8, 6-9
 - negotiated window size 6-8, 6-9
 - reverse-charge 6-8, 6-9
- field description
- Modify Keyboard Master panel 13-43
 - Printer Authorization Matrix Definition panel 10-4
 - RTM panel 5-8
 - X.25 Options panel 6-4
 - 117: Port Assignment Panel 4-7
 - 940: Ring Address Assignment panel 9-4
- field intensity 3-31
- file transfer aid 3-24
- filling out
- AEA configure worksheet 8-27
 - AEA default destination worksheet 8-43
 - AEA port set worksheet 8-27
 - AEA port to port set map worksheet 8-28
 - AEA station set worksheet 8-30
 - AEA worksheets 8-27
 - ASCII Attachment Diagram 8-14
 - Common SNA worksheet 7-4
 - Keyboard Changes Chart 11-5
 - keyboard worksheets 11-4
 - MLT worksheet 3-18
 - Printer Authorization Matrix worksheet 10-8
 - token-ring gateway worksheets 9-3
 - 117: port assignment worksheet (116=1) 4-9
 - 117: port assignment worksheet (116=2) 4-10
 - 128: RTM worksheet 5-11
 - 3270 Attachment Diagram 8-8
 - 332: X.25 Options worksheet 6-5

- Finnish, language code 3-21
- fixed disk
- copying from 15-5
 - copying to 15-4
 - deleting subdirectories 18-9
 - deselecting an IML source from 18-6
 - IMLing from 12-5
 - Merge DSL 14-6
 - selecting a subdirectory to copy 15-13
 - selecting an IML source from 18-6
 - subdirectories 18-3
 - what can be copied 15-4
- flow control type (731) 8-33
- flow of panels, Configure 13-9
- form feed
- local copy 3-31
 - use of (782) 8-43
- form feed, local copy 3-31
- French AZERTY, language code 3-21
- Full Copy 15-7
- selecting 15-12
- full- or half-speed transmission (318) 3-39
- function group 11-6
- function, alert (220) 3-34

G

- Gateway, address for 9-3
- general restrictions, keyboard 11-9
- General Telephone and Electronics (GTE) 6-5
- Greek, language code 3-21
- group
- function 11-6
 - keyboard 11-6
 - shift 11-6

H

- half-duplex SNBU operation 3-38
- hexadecimal polling address 3-12
- high speed data transfer 3-36
- HNAD (host network (DTE) address) 6-10
- Host Attachment worksheet 20-3
- host attachment (101) 3-11
- host configuration, CSCM 7-3
- host connection menu option (725) 8-33
- host copy operations 10-3
- host DTE address 6-8
- host DTE address (423) 6-10
- Host panel
- entering responses 13-14
- host services, warning 12-7, 12-10
- hot key, personal computers (168) 3-29

I

- I-frame size
- maximum inbound (370) 3-43

- I-frame size (*continued*)
 - maximum receive (380) 3-44
 - maximum transmission (382) 3-45
 - transmit (941) 9-5
 - IBM 3101 data stream, questions 8-41
 - 771 automatic line feed for cursor control 8-41
 - 772 carriage return/carriage return - line feed selection 8-42
 - 773 automatic new line for cursor control 8-42
 - 774 scrolling 8-42
 - 775 line turnaround character 8-42
 - Icelandic, language code 3-21
 - identification, physical unit (215) 3-33
 - identifier, connection 6-8, 6-9
 - identifier, logical channel (402) 6-5
 - identifier, machine (108) 3-16
 - Identifier, RPQ 13-32
 - Identify Customizing Keyboard
 - default keyboard 19-3
 - description of 1-10
 - panel 19-5
 - PF keys 19-4
 - procedure 19-4
 - selecting 19-4
 - when to 19-3
 - which ones to 19-3
 - IDs, keyboard 3-27
 - ID, network (501) 7-5
 - IML (Initial microcode load)
 - deselecting a source 18-3
 - selecting a source 18-3
 - source deselection procedure 18-6
 - source selection procedure 18-6
 - IML (initial microcode load), ALT 1 12-3
 - from a diskette 12-5
 - from a fixed disk 12-5
 - inserting diskettes 12-6
 - model 1L 12-10
 - overview 12-3
 - remote models 12-7
 - IML, warning 12-7, 12-10
 - IMS/VS 3-32
 - inactivity timeout (742) 8-37
 - individual port assignment (116) 3-20
 - initialize the Encrypt/Decrypt master key value 17-8
 - inserting diskettes 12-6
 - inserting the Encrypt/Decrypt security key 17-8
 - intensity
 - 3290 3-31
 - International, language code 3-21
 - interutility checking
 - Customize Control Disk A-7
 - description of A-3
 - Microcode Upgrade A-5
 - panel A-4
 - field description A-4
 - panel informational areas A-4
 - PF keys
 - customize control disk A-3
 - interutility checking (*continued*)
 - PF keys (*continued*)
 - microcode upgrade A-3
 - introduction to customizing 1-1
 - invalid responses, correcting 13-4
 - Italian, language code 3-21
 - I/O interface codes supported 11-17
- ## J
- Japanese (English), language code 3-21
 - Japanese (Katakana), language code 3-21
- ## K
- K-maximum out (433) 6-11
 - Katakana Keyboard worksheet 20-28
 - key
 - copying 11-15
 - direct and dial 3-42
 - disconnect 3-41
 - extension, X.21 switched 3-41
 - function nomenclature 11-18
 - local communicate 3-41
 - X.25 6-7
 - X.25 DISC 6-6
 - X.25 LOCAL and COMM 6-7
 - key function nomenclature 11-18
 - keyboard
 - additional extension mode key definition (168) 3-29
 - alternate selection (132) 3-25
 - APL 3-26
 - Attribute Select (166) 3-29
 - character set for 3-20
 - Data Entry 3-26
 - Enhanced Typewriter 3-26
 - group 11-6
 - identifying for customizing 19-1
 - IDs 3-27
 - languages for 3-20
 - languages supported 3-21, 11-17
 - selection, modifiable layouts (137) 3-27
 - selection, standard layouts (136) 3-26
 - types of 3-26
 - Typewriter 3-26
 - X.21 switched options (362) 3-41
 - Keyboard Changes Chart
 - column description 11-8
 - keyboard layouts
 - alternate B-3
 - APL B-6
 - AZERTY 19-3
 - Data Entry B-5
 - Enhanced Typewriter B-6
 - QWERTY 19-3
 - Typewriter B-5
 - Typewriter Base (4651) B-8
 - Typewriter Overlay Base (4640) B-8

Index

- keyboard layouts (*continued*)
 - Typewriter/APL Base (4652) B-8
 - 8K0808 B-3
 - 8K0932 (model C-4) B-3
 - 8K1038 (model C-3) B-3
 - 8K1158 B-4
- keyboard modification planning 11-1
 - APL restrictions 11-11
 - completing the worksheets 11-4
 - copying from one key to another 11-15
 - customizing questions to answer 11-11
 - deleting key functions 11-14
 - description of 11-3
 - general restrictions 11-9
 - key function nomenclature 11-18
 - Keyboard Changes Chart, completing 11-5
 - keyboards supported 11-17
 - languages supported 11-17
 - local function restrictions 11-10
 - nomenclature presentation restrictions 11-11
 - planning to modify 11-1
 - procedure for planning 11-4
 - sample Keyboard Changes Chart 11-8
 - setting up terminal keyboards 11-12
 - two-language modification 11-12
 - two-language modification, examples of 11-13
 - types of worksheets 11-4
- keyboards layouts
 - attribute select (166) B-8
- keyboards, base
 - 8K0808 3-25
 - 8K0932 3-25
 - 8K1038 3-25
 - 8K1158 3-25
- keyboards, customizing
 - default keyboard 19-3
 - identifying 19-4
 - panel for identifying 19-5
 - selecting 19-4
 - when to identify 19-3
 - which ones to identify 19-3
- Keyboards, Modify
 - after Microcode Upgrade 16-3
 - checking results 13-54
 - completing 13-55
 - copying 15-10
 - copying I/O interface 13-50
 - copying key function 13-52
 - deleting key function 13-53
 - description of 13-40
 - exchanging key function 13-51
 - exiting the procedure 13-54
 - keyboard panel 1 13-47
 - keyboard panel 2 13-47
 - keyboard panel 3 13-48
 - Master panel 13-43
 - modify the Master panel 13-43
 - PF keys 13-41
- Keyboards, Modify (*continued*)
 - procedure 13-41
 - selecting 13-42
 - selecting mode row entries 13-48
 - steps for defining 13-41
- keypad
 - data entry 3-28
 - national language numeric 3-28
 - program function 3-28
 - selection, standard layouts (138) 3-28
- keypad layouts
 - National Language Numeric, Data Entry, Program Function B-7
- keystroking, deferred 3-24
- keys, PF
 - AEA Configure 13-56
 - Configure 13-10
 - Copy 15-11
 - Customize Control Disk 13-5
 - Encrypt/Decrypt 17-5
 - Identify Customizing Keyboard 19-4
 - interutility checking A-3
 - Media Management 18-5
 - Merge DSL 14-5
 - Merge RPQs 13-34
 - Microcode Upgrade 16-6
 - Modify Keyboards 13-41
 - PAM 13-26
- L**
 - languages supported 3-21, 11-17
 - language, keyboard (121) 3-20
 - layout
 - AZERTY keyboard 19-3
 - QWERTY keyboard 19-3
 - layouts, modified, modifiable keyboards (137) 3-27
 - layouts, standard, modifiable keypads (138) 3-28
 - layout, standard, modifiable keyboards (136) 3-26
 - length, page (783) 8-43
 - levels
 - configuration 15-6, 16-4
 - maintenance 15-6, 16-4
 - microcode 15-6, 16-4
 - release 15-6, 16-4
 - suffix 15-6, 16-4
 - Library disk, copying 15-7
 - Limited Function Utility Disk
 - Copy panel C-2
 - copying 15-7
 - description of 1-5, C-1
 - menu panel C-1
 - option on C-1
 - used for C-1
 - line feed selection, carriage return/carriage return (772) 8-42
 - line speed (733) 8-35

line speed, ASCII host upper limit (734) 8-35
 line speed, maximum modem (737) 8-36
 line turnaround character (775) 8-42
 link level transmit timeout (450) 6-13
 link subsystem name (908) 9-4
 local copy
 for record-keeping 2-3
 format controls 3-31
 requesting 2-4
 with automatic form feed after 3-31
 with automatic form feed before 3-31
 local copy operations 10-3
 local copy, printing when customizing 13-3
 local function restrictions, keyboard 11-10
 LOCAL key, X.25 6-7
 local mode, printer 10-5
 local non-SNA 3-11
 local SNA 3-11
 Local (Non-SNA) worksheet 20-8
 Local (SNA) worksheet 20-9
 local, communicate key 3-41
 LOCATE command 13-29
 logical channel identifier (402) 6-5
 logical link control (402) 6-6
 logical unit name (LUNAME) (502) 7-5
 loss of customized data, warning 13-8, 13-25, 13-30,
 13-39, 13-55, 13-66
 loss of master key value, warning 17-8

M

machine, unique identifier (108) 3-16
 magnetic character set (141) 3-28
 maintenance level 15-6, 16-4
 making multiple copies 15-16
 management of customization data 2-6
 management of diskettes 2-6
 management, central site 7-3
 margin bell (764) 8-41
 master key value (MKV) 17-3
 master key value, warning 17-8
 Master Menu
 description of 1-8
 displaying 12-1
 displaying, model 1L 12-10
 displaying, remote models 12-7
 overview of displaying 12-3
 panel 12-3
 selecting options 12-9, 12-13
 using a diskette to display 12-5
 using a fixed disk to display 12-5
 Master Menu options
 Central Site Customizing 1-9
 Copy Files 1-8
 Customize the Control Disk 1-8
 Diagnostics 1-9
 Encrypt/Decrypt 1-9
 Identify Customizing Keyboard 1-10

Master Menu options (*continued*)
 Media Management 1-9
 Merge DSL Code 1-8
 Microcode Upgrade 1-9
 maximum
 inbound I-frame size (370) 3-43
 modem line speed (737) 8-36
 receive I-frame size (380) 3-44
 Token-Ring Network in (381) 3-44
 Token-Ring Network out (383) 3-45
 transmission I-frame size (382) 3-45
 maximum out 9-5
 measurement of response time 5-9
 Media Management
 deleting subdirectories 18-4, 18-9
 description of 1-9, 18-3
 deselecting the IML source 18-4, 18-6
 IML Source Selection panel 18-7
 options 18-4
 PF keys 18-5
 selecting 18-6, 18-9
 selecting the IML source 18-4, 18-6
 subdirectories 18-3
 verify drives 18-7, 18-10
 warning 18-3
 memory requirements
 asynchronous emulation adapter (AEA) 3-7, 8-5
 central site change management (CSCM) 3-7
 multiple logical terminals (MLT) 3-7
 token-ring 3270 gateway 3-7
 menu
 connection, AEA 8-3
 Customize Control Disk 13-8
 Master 13-6
 terminal type, AEA 8-3
 menu options, description of
 Customize Control Disk 1-11
 Master Menu 1-8
 menu option, host connection (725) 8-33
 menu option, selecting
 AEA Configure 13-58
 Configure 13-12
 Copy 15-11
 Customize Control Disk 13-6
 Define the PAM 13-28
 Encrypt/Decrypt 17-5
 from Customize Control Disk Menu 13-8
 Identify Customizing Keyboard 19-4
 Media Management 18-6, 18-9
 Merge DSL 14-5
 Merge RPQs 13-35
 Microcode Upgrade 16-6
 Modify Keyboards 13-42
 Merge DSL
 after Microcode Upgrade 16-3
 description of 14-3
 multiple merges 14-9
 option description 1-8

Index

- Merge DSL (*continued*)
 - panel 14-4
 - PF keys 14-5
 - procedure 14-5
 - select Merge/Delete 14-8
 - selecting 14-5
 - using a diskette 14-6
 - using a fixed disk 14-6
 - when to 14-3
- Merge RPQs
 - after Microcode Upgrade 16-3
 - completing 13-39
 - copying RPQs 15-10
 - description of 1-12, 13-31
 - merge panel 13-33
 - PF keys 13-34
 - procedure 13-34
 - RPQ Identifier 13-32
 - RPQ Parameter List 13-32
 - selecting 13-35
 - selecting Include, Omit, or Delete 13-37
 - selecting Merge 13-38
 - Utility panel 13-31
 - verify drives 13-36, 13-37
- methods of record-keeping 2-3
 - using a printer 2-3
 - using diskettes 2-5
 - using worksheets 2-5
- microcode
 - Control 1-5
 - DSL (downstream load) 1-5
 - Encrypt/Decrypt 1-6
 - kinds of 1-5
 - LFU (limited function utility) 1-5
 - RPQ (request for price quotation) 1-5
 - Utility 1-5
- microcode level
 - determining 15-6, 16-4
 - releases 1-6
- Microcode Upgrade
 - description of 1-9, 16-3
 - error correction procedure A-5
 - errors panel A-5
 - interutility checking A-5
 - interutility checking, PF keys A-3
 - multiple times 16-9
 - New heading 16-5
 - Old heading 16-5
 - PF keys 16-6
 - planning 16-3
 - procedure 16-6
 - procedures performed after 16-3
 - selecting 16-6
 - Upgrade panel 16-5
 - verify drives 16-8
- miscellaneous feature options (125) 3-22
 - background alarm 3-24
 - clicker option 3-23
- miscellaneous feature options (125) (*continued*)
 - deferred keystroking (remote SNA) 3-24
 - dual-function clear key 3-23
 - file transfer aid 3-24
 - PS load altered screen 3-23
 - unsupported control code translate 3-23
- MLT (multiple logical terminals) 3-17
 - completing the worksheet 3-18
 - configuration level (110) 3-17
 - considerations with AEA 8-5
 - description of 3-17
 - determining the level of 3-18
 - related considerations 3-19
 - storage requirements 3-7
 - warning 3-18
 - worksheet 20-25
- mode of data transfer (224) 3-36
- model designation (100) 3-10
- model 1L
 - displaying the Master Menu 12-10
- models, diagram of
 - 1L, 1R, 2R, and 3R 12-4
 - 51R, 52R, and 53R 12-4
 - 81R and 82R 12-5
- Model/Attach panel
 - entering responses 13-13
- modem
 - Hayes embedded character substitution 8-39
 - IBM embedded character substitution 8-39
 - Micom embedded character substitution 8-39
 - translated character 8-40
 - translated character string 8-40
- modes, data transfer 3-35
- modifiable keyboard
 - modified layouts (137) 3-27
 - standard layouts (136) 3-26
- modifiable keyboards, standard layouts (136)
 - diagram of B-5
- modifiable keypads, standard layouts (138)
 - diagram of B-7
- modifiable keypads: standard layouts (138) 3-28
- modification
 - examples of two-language 11-13
 - two-language 11-12
- modified layouts, modifiable keyboards (137) 3-27
- Modify and Copy 15-8
 - defining the modified responses 15-15
 - selecting 15-12
- Modify and Copy panel 15-15
- Modify Keyboard Master panel 13-43
 - description of fields 13-43
- Modify Keyboards 11-1, 13-55
 - after Microcode Upgrade 16-3
 - APL restrictions 11-11
 - checking results 13-54
 - completing 13-55
 - completing the worksheets 11-4
 - copying 15-10

Modify Keyboards (continued)

- copying from one key to another 11-15
 - copying I/O interface 13-50
 - copying key function 13-52
 - customizing questions to answer 11-11
 - deleting key function 13-53
 - deleting key functions 11-14
 - description of 1-12, 11-3, 13-40
 - exchanging key function 13-51
 - exiting the procedure 13-54
 - general restrictions 11-9
 - I/O interface codes supported 11-17
 - key function nomenclature 11-18
 - Keyboard Changes Chart, completing 11-5
 - keyboard panel 1 13-47
 - keyboard panel 2 13-47
 - keyboard panel 3 13-48
 - languages supported 11-17
 - local function restrictions 11-10
 - Master panel 13-43
 - modify the Master panel 13-43
 - modifying panels 13-46
 - nomenclature presentation restrictions 11-11
 - PF keys 13-41
 - planning 11-1
 - planning procedure 11-4
 - procedure 13-41
 - sample Keyboard Changes Chart 11-8
 - selecting 13-42
 - selecting mode row entries 13-48
 - setting up terminal keyboards 11-12
 - steps for defining 13-41
 - two-language modification 11-12
 - two-language modification, examples of 11-13
 - types of worksheets 11-4
 - warning 13-42, 13-46, 13-55
- Modulo 8 and 128 6-11
- monitor, ring error (905) 9-3
- multiple upgrades of microcode 16-9

N

- national language numeric keypad, response for 3-28
- negotiated packet size facility 6-8, 6-9
- negotiated packet size (430) 6-10
- negotiated window size facility 6-8, 6-9
- negotiated window size (432) 6-11
- negotiated, throughput class 6-8
- Netherlands, language code 3-21
- network diskettes, management of 2-6
- network ID, NETID (501) 7-5
- Network Site Control Unit 7-4
- network subscription 6-3
- network type (400) 6-5
- networks, switched 3-38
- New Belgian, language code 3-21
- new line option (763) 8-41

- New Swiss French, language code 3-21
- New Swiss German, language code 3-21
- nomenclature presentation restrictions, keyboard 11-11
- nomenclature, key function 11-18
- Non-Katakana Keyboard worksheet 20-27
- nonreturn to zero inverted (NRZI) 3-37
- nonreturn to zero (NRZ) 3-37
- nonstandard default packet size (434) 6-11
- nonstandard default window size (435) 6-12
- nonswitched facilities 3-38
- normal data transfer 3-36
- Norwegian, language code 3-21
- NPKT (negotiated packet size) 6-10
- NRZ or NRZI encoding (313) 3-37
- NRZ (nonreturn to zero) 3-37
- NRZI (nonreturn to zero inverted) 3-37
- number of retries (451) 6-14
- numbering attachment diagrams 8-25
- numbering, packet sequence (431) 6-11
- NWND (negotiated window size) 6-11

O

- OIA
 - See operator information area
- operation
 - disconnect/local mode, X.25 6-7
- operation, connect-data-set-to-line (310) 3-37
- operation, half-duplex SNBU 3-38
- operator information area (OIA) 2-3
- operator-generated alert 3-34
- option
 - clicker 3-23
 - distributed function terminals 3-30
 - field intensity 3-31
 - incoming call (420) 6-7
 - miscellaneous feature (125) 3-22
 - new line (763) 8-41
 - outgoing call (421) 6-9
 - RTS control response (340) 3-39
 - wraparound (762) 8-40
 - X.21 switched (362) 3-41
 - X.25 keyboard support (409) 6-6
 - X.25 (3320) 3-39
 - X.25 (332) 6-3
- option selection
 - AEA Configure 13-58
 - Configure 13-12
 - Copy 15-11
 - Customize Control Disk 13-6
 - Define the PAM 13-28
 - Encrypt/Decrypt 17-5
 - from Customize Control Disk Menu 13-8
 - Identify Customizing Keyboard 19-4
 - Media Management 18-6, 18-9
 - Merge DSL 14-5
 - Merge RPQs 13-35

Index

option selection (*continued*)

- Microcode Upgrade 16-6
- Modify Keyboards 13-42

order of copy, warning 15-5

overview

- AEA Configure 13-56
- Asynchronous Emulation Adapter (AEA) 8-6
- Central Site Change Management 7-3
- Configure 13-9
- Copy 15-3
- Customize Control Disk 13-3
- displaying the Master Menu 12-3
- Encrypt/Decrypt 17-3
- Limited Function Utility Disk C-1
- Media Management 18-3
- Merge DSL Code 14-3
- Merge RPQs 13-31
- Microcode Upgrade 16-3
- Modify Keyboards 11-3, 13-40
- port assignment 4-3
- printer authorization matrix 10-3
- Printer Authorization Matrix (PAM) 13-26
- Response Time Monitor (RTM) 5-3
- X.25 6-3

P

packet sequence numbering (431) 6-11

packet size facility, negotiated 6-8, 6-9

packet size, negotiated (430) 6-10

page length (783) 8-43

PAM

- See Printer Authorization Matrix (PAM)

PAM worksheet, completing 10-8

PAM, copying 15-9

- selecting 15-12

panel

- Master Menu 12-3

panels

- AEA Configure 13-59
- AEA Configure Complete panel 13-65
- AEA Default Destination 13-64
- AEA Port Set 8-29, 13-60
- AEA Port to Port Set Map 8-29, 13-61
- AEA Station Set 13-62
- Common SNA 7-4, 13-18
- Configure Complete 13-24
- Copy Menu panel 15-3, 15-12
- Customize Control Disk Menu 1-11, 13-8
- customizing 1-13
- Customizing Errors A-7
- Customizing Keyboard Type 19-5
- description of 1-13
- DSL Merge 14-4
- Encrypt/Decrypt Utility 17-4
- flow of during Configure 13-9
- Host 13-14
- IML Source Selection 18-7

panels (*continued*)

- interutility checking A-4
 - LFU Copy C-2
 - Master Menu 1-8, 13-6
 - Limited Function Utility Disk C-1
 - Media Management Menu 18-4
 - menu panel 18-4
 - Microcode Upgrade 16-5
 - Microcode Upgrade Errors A-5
 - Model/Attach 13-13
 - Modify and Copy 15-15
 - Modify Keyboard Master 13-43
 - PAM Definition 13-29
 - Printer Authorization Matrix Definition 10-4
 - RPQ Merge 13-33
 - RPQ Utility 13-31
 - sample 1-13
 - Subdirectory Selection 15-5
 - Token-Ring Gateway 13-15
 - Typewriter Keyboard Panel 1 13-47
 - Typewriter Keyboard Panel 2 13-47
 - Typewriter Keyboard Panel 3 13-48
 - X.25 Options 3-39
 - 117: Port Assignment 3-20, 4-7, 13-19
 - 118: port address 3-20, 4-11
 - 128: RTM 3-25, 5-3, 5-7
 - version A 5-7, 13-21
 - version B 5-8, 13-22
 - 332: X.25 Options 6-4, 13-23
 - 940: Ring Address Assignment 13-16
 - 941: Ring Transmission Definition 13-17
- ### Parameter List, RPQ 13-32
- ### parity (735) 8-36
- ### password
- connection identifier 6-14
 - for ASCII display stations 8-27
 - 3179G 3-32
 - 3290 3-32
- ### Patch(es), copy 15-10
- selecting 15-12
- ### pattern diskette 3-4
- ### PA3 key, warning 11-4, 13-42
- ### permanent request-to-send 3-39
- ### personal computers, additional extension-mode key definition (168) 3-29
- ### PF (program function) keys
- AEA Configure 13-56
 - Configure procedure 13-10
 - Copy 15-11
 - Customizing Control Disk 13-5
 - Encrypt/Decrypt 17-5
 - Identify Customizing Keyboard 19-4
 - interutility checking
 - customize control disk A-3
 - microcode upgrade A-3
 - Media Management 18-5
 - Merge DSL 14-5
 - Merge RPQs 13-34

- PF (program function) keys (*continued*)
 - Microcode Upgrade 16-6
 - Modify Keyboards 13-41
 - PAM 13-26
- PF3 key, warning 13-24, 13-65
- phone number, ASCII host (752) 8-38
- physical service header (PSH) 6-6
- physical unit identification (215) 3-33
- planning
 - AEA 8-1
 - AEA tasks 8-6
 - Central Site Change Management 7-1
 - configuration 3-2
 - for port assignment 4-1
 - for 3174 1-4
 - Modify Keyboards 11-1
 - parts of the process 3-3
 - Printer Authorization Matrix (PAM) 10-1
 - reason for 3-3
 - reconfigure 3-46
 - Response Time Monitor (RTM) 5-1
 - steps for configuring 3-5
 - steps for storage 3-7
 - Token-Ring Network 3270 Gateway 9-1
 - X.25 6-1
- polling address 3-12
- port address panel (118) 4-11
- port address (118) 3-20
- port assignment
 - AEA considerations 4-5
 - assigning host addresses per port 4-4
 - automatic assignment 4-3
 - changing port assignments 4-12
 - completing the worksheet (116=1) 4-9
 - completing the worksheet (116=2) 4-10
 - CUT devices using MLT function 4-5
 - defining host addresses per port 4-4
 - description of 4-3
 - DFT considerations 4-5
 - panel field description 4-7
 - planning for 4-1
 - restriction on using port 26-00 4-6
 - 117: port assignment panel 4-6
 - 118: port address table 4-11
- Port Assignment panel (117) 4-7
- Port Assignment worksheet 20-14
- Port Assignment (117) 3-20
- port assignment, individual (116)
 - ASCII, DFT, 7232 devices 3-20
- port set name (723) 8-33
- Port Set panel, AEA 8-29
- port set, AEA 8-4
- Port to Port Set Map panel, AEA 8-29
- Portuguese, language code 3-21
- Printer Authorization Matrix (PAM) 10-1
 - completing 13-30
 - completing the worksheet 10-8
 - copying 15-9
- Printer Authorization Matrix (PAM) (*continued*)
 - Definition panel, fields 10-4
 - class 10-6
 - display port 10-6
 - entry 10-4
 - mode 10-5
 - printer port 10-5
 - description of 10-3, 13-26
 - LOCATE command 13-29
 - panels, entering responses 13-29
 - PF keys 13-26
 - planning 10-1
 - procedure 13-26
 - sample PAM 10-7
 - selecting 13-28
 - worksheet 20-17
- printer, for record-keeping 2-3
- printing a local copy 13-3
- private operating agency, recognized (442) 6-13
- problem determination
 - error correction
 - Customize Control Disk A-7
 - Microcode Upgrade A-5
 - interutility checking A-3
 - panel informational areas A-4
 - utility checking panel A-4
- procedure 8-14
 - AEA Configure 13-56
 - ASCII attachment diagram, filling out 8-14
 - configuration planning 3-5
 - Configure 13-10
 - Copy 15-11
 - Customize Control Disk 13-6
 - Define the PAM 13-26
 - deleting subdirectories 18-9
 - deselecting the IML source 18-6
 - diskette management 2-6
 - displaying the Master Menu, model 1L 12-10
 - displaying the Master Menu, remote models 12-7
 - Encrypt/Decrypt 17-5
 - error correction
 - Customize Control Disk A-7
 - Microcode Upgrade A-5
 - filling out AEA worksheets 8-27
 - filling out common SNA worksheet 7-4
 - filling out MLT worksheet 3-18
 - filling out PAM worksheet 10-8
 - filling out RTM worksheet 5-11
 - filling out X.25 Options worksheet 6-5
 - filling out 3270 attachment diagram 8-8
 - filling out, 117: port assignment worksheet
 - (116=1) 4-9
 - filling out, 117: port assignment worksheet (116=2) 4-10
 - Identify Customizing Keyboard 19-4
 - inserting diskettes 12-6
 - Keyboard Changes Chart, completing 11-5
 - keyboard worksheets, completing 11-4

Index

- procedure (*continued*)
 - management of customization data 2-6
 - Media Management 18-6, 18-9
 - Merge DSL 14-5
 - Microcode Upgrade 16-6
 - Modify Keyboards 13-41
 - numbering AEA attachment diagrams 8-25
 - reconfiguring 13-10
 - RPQ Merge 13-34
 - selecting the IML source 18-6
 - storage planning 3-7
 - process
 - configuration planning 3-5
 - storage planning 3-7
 - product assistance data (099) 3-10
 - program function keypad, response for 3-28
 - program symbols, compressed (165) 3-29
 - prompt for attached printer (781) 8-42
 - prompt for universal/specific keyboard map (743) 8-38
 - protecting data 17-3
 - PS load altered screen 3-23
 - PSH (physical service header) 6-6
 - PSTN (public switched telephone network) 3-38
 - purpose of record-keeping 2-3
- Q**
- qualified logical link (QLLC) 6-6
 - questions for
 - AEA station type 8-31
 - DECVT100 data stream 8-40
 - IBM 3101 data stream 8-41
 - QWERTY keyboard layout 19-3
- R**
- radio frequency iii
 - warning iii
 - receive window size 3-44
 - receive window size and transmit window size, relationship
 - receive window size, recommended setting 9-6
 - recognized private operating agency (442) 6-13
 - reconfigure, planning 3-46
 - reconfiguring
 - AEA 13-56
 - Control disk 13-9
 - procedure 13-10
 - the PAM 13-26
 - record-keeping
 - methods of 2-3
 - purpose of 2-3
 - using a printer 2-3
 - using diskettes 2-5
 - using worksheets 2-5
 - release level 15-6, 16-4
 - release levels, microcode 1-6
 - remote models
 - displaying the Master Menu 12-7
 - request-to-send control options (340) 3-39
 - requesting a local copy 2-4
 - response time measurement 5-9
 - Response Time Monitor (RTM)
 - boundaries and interface (128) 3-25
 - changing specifications 5-12
 - completing the worksheet 5-11
 - defining 5-3
 - definition (127) 3-24
 - description of 5-3
 - description of fields on panel 5-8
 - first-digit response 5-4
 - planning for 5-1
 - sample boundaries 5-9
 - second-digit response 5-5
 - specifying boundaries, RTM 5-7
 - 128 panel 5-3
 - responses, correcting 13-4
 - responses, entering
 - AEA Configure panel 13-59
 - AEA Default Destination panel 13-64
 - AEA Port Set panel 13-60
 - AEA Port to Port Set Map panel 13-61
 - AEA Station Set panel(s) 13-62
 - Common SNA panel 13-18
 - Encrypt/Decrypt panel 17-9
 - Host panel 13-14
 - in general 13-3
 - Model/Attach panel 13-13
 - PAM panel(s) 13-29
 - Token-Ring Network Gateway panels 13-15
 - 117: Port Assignment panel 13-19
 - 128: RTM panel 13-21
 - 332: X.25 Options panel 13-23
 - restrictions for modifying keyboards 11-9
 - APL 11-11
 - general 11-9
 - local functions 11-10
 - nomenclature presentation 11-11
 - restrictions, copy 15-4
 - restrictions, using port 26-00 4-6
 - retries, number of (451) 6-14
 - retry
 - X.21 switched timing (361) 3-40
 - X.21 switched (360) 3-40
 - retry, command (222) 3-34
 - reverse-charge facility 6-8, 6-9
 - Ring Address Assignment panel, (940)
 - field description 9-4
 - Ring Address Assignment worksheet 20-12
 - ring address assignment (940) 9-4
 - ring error monitor (905) 9-3
 - Ring Transmission Definition worksheet 20-13
 - ring transmission definition (941) 9-5
 - ROECE, language code 3-21

- RPOA (recognized private operating agency) 6-13
 - RPQ Identifier 13-32
 - RPQ Merge
 - after Microcode Upgrade 16-3
 - completing 13-39
 - copying RPQs 15-10
 - description of 13-31
 - merge panel 13-33
 - PF keys 13-34
 - procedure 13-34
 - RPQ Identifier 13-32
 - RPQ Parameter List 13-32
 - selecting 13-35
 - selecting Include, Omit, or Delete 13-37
 - selecting Merge 13-38
 - Utility panel 13-31
 - verify drives 13-36, 13-37
 - RPQ Merge, copying 15-10
 - selecting 15-12
 - RPQ Parameter List 13-32
 - RPQ (request for price quotation) diskette
 - description of 1-5
 - RPQs, warning 13-39
 - RTM
 - See Response Time Monitor
- S**
- safety iii
 - warning iii
 - sample Keyboard Changes Chart 11-8
 - sample panel, customizing 1-13
 - saving
 - AEA configure data 13-65
 - configuration data 13-24
 - customizing data 13-67
 - Merge RPQ data 13-39
 - Modify Keyboard data 13-55
 - PAM data 13-30
 - screen, PS load altered 3-23
 - scrolling (774) 8-42
 - SDLC worksheet 20-6
 - SDLC (Synchronous Data Link Control) 3-11
 - security 17-3
 - connection identifier password 6-14
 - DFT password 3-32
 - password for ASCII display stations 8-27
 - security keylock, warning 17-15
 - security key, warning 17-8
 - select IML source 18-4
 - select option
 - AEA Configure 13-58
 - Configure 13-12
 - Copy 15-11
 - Customize Control Disk 13-6
 - Define the PAM 13-28
 - Encrypt/Decrypt 17-5
 - from Customize Control Disk Menu 13-8
 - select option (*continued*)
 - Identify Customizing Keyboard 19-4
 - Media Management 18-6, 18-9
 - Merge DSL 14-5
 - Merge RPQs 13-35
 - Microcode Upgrade 16-6
 - Modify Keyboards 13-42
 - selecting an IML source
 - procedure 18-6
 - selection, alternate base keyboard (132) 3-25
 - selection, alternate keyboard (132)
 - layouts of B-3
 - setting up terminal keyboards 11-12
 - shared copy operations 10-3
 - shared mode, printer 10-5
 - sharing, between bracket (213) 3-33
 - shift group 11-6
 - short-hold mode dial number, X.21 switched (368) 3-43
 - short-hold mode, X.21 switched (367) 3-43
 - SNA panel, common 7-4
 - SNA (systems network architecture) 5-3
 - SNBU (switched network backup) 3-38
 - Spanish-speaking, language code 3-21
 - Spanish, language code 3-21
 - specification change, RTM 5-12
 - specification, RTM boundaries and interface (128) 3-25
 - specifying keyboard language, warning 11-5
 - speed, ASCII host upper limit (734) 8-35
 - speed, line (733) 8-35
 - standard layouts, modifiable keyboards (136) 3-26
 - diagram of B-5
 - standard layouts, modifiable keypads (138)
 - diagram of B-7
 - station set name (721) 8-32
 - station set, AEA 8-4
 - station type
 - ASCII 8-32
 - 3270 8-32
 - station type questions
 - list of 8-31
 - station type (722) 8-32
 - station, AEA 8-4
 - stop bits (736) 8-36
 - storage requirements 3-7
 - asynchronous emulation adapter (AEA) 3-7, 8-5
 - central site change management (CSCM) 3-7
 - multiple logical terminals (MLT) 3-7
 - token-ring 3270 gateway 3-7
 - subdirectories
 - deleting 18-4, 18-9
 - deselecting 18-4
 - IMLing from 18-4
 - on a fixed disk 18-3
 - selecting 18-4
 - subdirectories on a fixed disk 15-4

Index

- subdirectory
 - selecting for copy 15-13
- Subdirectory Selection panel 15-5
- subscription, network 6-3
- subsystem name, link (908) 9-4
- suffix level 15-6, 16-4
- support
 - I/O interface codes 3-21, 11-17
 - keyboards 3-21, 11-17
 - languages 3-21, 11-17
 - 123 country extended code page (CECP) 3-22
- Swedish, language code 3-21
- switched disconnect timeout (741) 8-37
- switched networks 3-38
- switching, 7232 dual control unit multiplexer (178) 3-33
- symbols, compressed program (165) 3-29
- system mode, printer 10-5

T

- TCLS (throughput class negotiation) 6-12
- telecommunication facilities (317) 3-38
- TELENET 6-5
- terminal emulation
 - ASCII 8-4
 - 3270 8-4
- terminal equipment address 6-10
- terminal keyboards
 - setting up 11-12
- terminal options, DFT 3-30
- terminal type menu, AEA 8-3
- terminals, assigning to ports 4-6
- terminology, AEA 8-3
- test the Encrypt/Decrypt feature 17-15
- Thai, language code 3-21
- throughput class 6-10
- throughput class negotiation 6-8
- throughput class negotiation (440) 6-12
- time measurement, response 5-9
- timeout, inactivity (742) 8-37
- timeout, switched disconnect (741) 8-37
- Token-Ring Network 3-11
 - address of the gateway (107) 3-16
 - address of the 3174 (106) 3-15
 - maximum in (381) 3-44
 - maximum out (383) 3-45
 - worksheet 20-10
 - 3174 address warning 3-15
- Token-Ring Network Gateway questions 9-3
 - 900 address for the Gateway 9-3
 - 905 ring error monitor 9-3
 - 908 link subsystem name 9-4
 - 940 ring address assignment 9-4
 - 941 ring transmission definition 9-5
- Token-Ring Network 3270 Gateway 9-1
 - completing the worksheets 9-3
 - entering responses on the panels 13-15

- Token-Ring Network 3270 Gateway (*continued*)
 - planning 9-1
 - storage requirements 3-7
 - worksheet 20-11
- transfer delay, X.21 data (365) 3-42
- transfer of RPQs, warning 13-39
- transfer, data mode (224) 3-36
- translated character string 8-40
- translated modem character 8-40
- translate, unsupported control code 3-23
- transmission
 - full- or half-speed 3-39
 - maximum I-frame size (382) 3-45
 - resumption trigger, XON/XOFF (732) 8-34
- transmit I-frame size 9-5
- transmit timeout, link level (450) 6-13
- transmit window size 3-44, 9-5
- transmit window size and receive window size, relationship
- transmit window size, recommended setting 9-6
- Turkish, language code 3-21
- turnaround character, line (775) 8-42
- two-language modification 11-12
 - examples of 11-13
- type of flow control (731) 8-33
- Typewriter Base keyboard, layout B-8
- Typewriter Keyboard Panel 1 13-47
- Typewriter Keyboard Panel 2 13-47
- Typewriter Keyboard Panel 3 13-48
- Typewriter keyboard, response for 3-26
- Typewriter Overlay Base keyboard, layout B-8
- Typewriter/APL Base keyboard, layout B-8

U

- unique characters
 - APL2, warning 13-46
 - CECP, warning 13-46
- unique characters, warning
 - APL2 11-5
 - CECP 11-5
- unique machine identifier (108) 3-16
- unit name, logical (502) 7-5
- universal address 9-4
- universal/specific keyboard map, prompt for (743) 8-38
- unlabeled PA3 key, warning 11-4, 13-42
- unsupported control code translate 3-23
- update panel before allowing buffer change 3-32
- upgrading microcode
 - description of 16-3
 - error correction procedure A-5
 - errors panel A-5
 - interutility checking A-5
 - interutility checking, PF keys A-3
 - multiple times 16-9
 - New heading 16-5
 - Old heading 16-5

upgrading microcode (*continued*)

- PF keys 16-6
- planning 16-3
- procedure 16-6
- procedures performed after 16-3
- selecting option for 16-6
- Upgrade panel 16-5
- verifying drives 16-8

upper limit address (105) 3-14

use of form feed (782) 8-43

user group, closed (441) 6-13

Utility disk

- copying 15-7
- Customize Control Disk Menu 1-11
- description of 1-5
- Master Menu 1-8

Utility disk options

- AEA Configure 1-12
- Central Site Customizing 1-9
- Configure 1-11
- Copy Files 1-8
- Customize the Control Disk 1-8
- Define PAM (printer authorization matrix) 1-11
- Diagnostics 1-9
- Encrypt/Decrypt 1-9
- Identify Customizing Keyboard 1-10
- Media Management 1-9
- Merge DSL Code 1-8
- Merge RPQs 1-12
- Microcode Upgrade 1-9
- Modify Keyboards 1-12

V

verification pattern (VP) 17-3

verify drives

- Copy 15-13
- Customize Control Disk 13-7
- Encrypt/Decrypt 17-6, 17-7
- Media Management 18-7, 18-10
- Merge RPQs 13-36, 13-37

verify the Encrypt/Decrypt master key value 17-13

version A of the 128: RTM panel 5-7

version B of the 128: RTM panel 5-8

W

WACK (wait before transmit positive acknowledgment) 3-32

warning

- AEA Configure 13-65
- APL2 11-5, 13-46
- CECP 11-5, 13-46
- Configure complete 13-24, 13-25, 13-30, 13-39, 13-55, 13-65, 13-66
- configure procedure 13-24
- Converged Typewriter keyboard 13-42
- copy 15-5

warning (*continued*)

- Customize Control Disk 13-8, 13-25, 13-30, 13-39, 13-55, 13-66
- default IML 18-3
- during Alt 1 IML 12-7, 12-10
- Encrypt/Decrypt 17-8, 17-15
- loss of the master key value 17-8
- Media Management 18-3
- Modifying Keyboards 13-46
- PA3 key 11-4, 13-42
- radio frequency iii
- safety iii
- security keylock 17-15
- specifying keyboard language 11-5
- unique characters 13-46
- 106 Token-Ring network address of the 3174 3-15
- 110 MLT configuration level 3-18
- 123 country extended code page 3-22
- 3270 host sessions 3-18
- window size facility, negotiated 6-8, 6-9
- window size, negotiated (432) 6-11
- window size, nonstandard default (435) 6-12
- window size, transmit 9-5
- worksheets
 - AEA Configure 20-20
 - AEA Default Destination 20-24
 - AEA Port Set 20-21
 - AEA Port to Port Set Map 20-22
 - AEA Station Set 20-23
 - ASCII Attachment Diagram 20-19
 - BSC 20-4
 - Common SNA 20-26
 - Configuration Questions Summary 20-32
 - configuration, description of 2-5
 - Enhanced Typewriter Keyboard (Katakana) 20-31
 - Enhanced Typewriter Keyboard (U.S.) 20-29
 - Enhanced Typewriter Keyboard (World Trade) 20-30
 - for record-keeping 2-5
 - Host Attachment 20-3
 - Katakana Keyboard 20-28
 - Local (Non-SNA) 20-8
 - Local (SNA) 20-9
 - Multiple Logical Terminals 20-25
 - Non-Katakana Keyboard 20-27
 - Port Assignment 20-14
 - Printer Authorization Matrix 20-17
 - Ring Address Assignment 20-12
 - Ring Transmission Definition 20-13
 - SDLC 20-6
 - Token-Ring Gateway 20-11
 - Token-Ring Network 20-10
 - X.21 Switched 20-7
 - X.25 20-5
 - X.25 Options 20-16
 - 128: Response Time Monitor 20-15
 - 3270 Attachment Diagram 20-18

Index

wraparound option (762) 8-40

X

XON/XOFF transmission resumption trigger (732) 8-34

XON/XOFF, auto (761) 8-40

X.21

data transfer delay (365) 3-42

response for host attachment 3-11

X.21 switched

options (362) 3-41

DCE supported for address calls 3-42

DCE supported for direct calls 3-42

disconnect key 3-41

extension key 3-41

local, communicate key 3-41

retry timing (361) 3-40

retry (360) 3-40

short-hold mode dial number (368) 3-43

short-hold mode (367) 3-43

worksheet 20-7

X.25

changing options 6-15

completing worksheet 6-5

description of 6-3

DISC key 6-6

keys 6-7

LOCAL and COMM keys 6-7

network subscription 6-3

Options panel, field description 6-4

Options worksheet 20-16

options (332) 3-39, 6-3

planning for 6-1

response for host attachment 3-11

worksheet 20-5

X.25 configuration questions 6-5

400 network type 6-5

401 circuit type 6-5

402 logical channel identifier 6-5

402 logical link control 6-6

409 X.25 keyboard support options 6-6

420 incoming call options 6-7

421 outgoing call options 6-9

423 host DTE address 6-10

424 3174 DTE address 6-10

430 negotiated packet size 6-10

431 packet sequence numbering 6-11

432 negotiated window size 6-11

433 K-maximum out 6-11

434 nonstandard default packet size 6-11

435 nonstandard default window size 6-12

440 throughput class negotiation 6-12

441 closed user group 6-13

442 recognized private operating agency 6-13

450 link level transmit timeout 6-13

451 number of retries 6-14

452 connection identifier password 6-14

X.25 incoming call options (420) 6-7

connection identifier 6-8

host DTE address 6-8

negotiated packet size facility 6-8

negotiated window size facility 6-8

reverse-charge facility 6-8

throughput class negotiation 6-8

X.25 keyboard support options (409) 6-6

dial screen display 6-7

disconnect/local mode operation 6-7

X.25 DISC key 6-6

X.25 keys 6-7

X.25 LOCAL and COMM keys 6-7

X.25 outgoing call options (421) 6-9

connection identifier 6-9

negotiated packet size facility 6-9

negotiated window size facility 6-9

reverse-charge facility 6-9

throughput class 6-10

3174 DTE address 6-9

Y

Yugoslavic, language code 3-21

Numerics

106 Token-Ring network address of the 3174,
warning 3-15

110 MLT configuration level, warning 3-18

117: port assignment 3-20

117: Port Assignment panel 4-7

description of fields 4-7

entering responses 13-19

118: port address 3-20

123 country extended code page, warning 3-22

128: Response Time Monitor worksheet 20-15

128: RTM panel 5-3

entering responses 13-21

field description 5-8

128: RTM panel (version A) 5-7

128: RTM panel (version B) 5-8

3174 compatibility

with 3270 Information Display System 3-4

with 3290 Information Panel 3-4

3174 DTE address 6-9

3174 DTE address (424) 6-10

3174 models, diagram of

1L, 1R, 2R, and 3R 12-4

51R, 52R, and 53R 12-4

81R and 82R 12-5

3174 Subsystem Control Unit

Alt 1 IMLing 12-3

inserting diskettes 12-6

supported devices 1-3

3179G options (173) 3-30

3179G password (175) 3-32

- 3270 Attachment Diagram worksheet 20-18
- 3270 host session, warning 3-18
- 3270 Information Display System
 - compatibility with 3174 3-4
- 3270 station type
 - display station 8-32
 - host 8-32
 - printer 8-32
- 3270 terminal emulation 8-4
- 3290 field intensity 3-31
- 3290 Information Panel
 - compatibility with 3174 3-4
- 3290 options (173) 3-30
- 3290 password (175) 3-32
- 332: X.25 Options panel
 - entering responses 13-23
 - field description 6-4
- 7232 dual control unit terminal multiplexer Switching (178) 3-33
- 7232, individual port assignment 3-20
- 8K0808 keyboard 3-25
- 8K0808, base keyboard layout B-3
- 8K0932 keyboard 3-25
- 8K0932 (model C-4), base keyboard layout B-3
- 8K1038 keyboard 3-25
- 8K1038 (model C-3), base keyboard layout B-3
- 8K1158 keyboard 3-25
- 8K1158, base keyboard layout B-4
- 940: Ring Address Assignment panel
 - field description 9-4

**3270 Information Display System
3174 Subsystem Control Unit
Customizing Guide
Configuration A/S Release 4**

**READER'S
COMMENT
FORM**

Publication No. GA23-0214-3

This manual is part of a library that serves as a reference source for systems analysts, programmers, and operators of IBM systems. You may use this form to communicate your comments about this publication, its organization, or subject matter, with the understanding that IBM may use or distribute whatever information you supply in any way it believes appropriate without incurring any obligation to you.

Note: Copies of IBM publications are not stocked at the location to which this form is addressed. Please direct any requests for copies of publications, or for assistance in using your IBM system, to your IBM representative or to the IBM branch office serving your locality.

Possible topics for comment are:

Clarity Accuracy Completeness Organization Coding Retrieval Legibility

If you wish a reply, give your name, company, mailing address, date, and location of your local IBM branch office:

What is your occupation? _____

Number of latest Newsletter associated with this publication: _____

Thank you for your cooperation. No postage stamp necessary if mailed in the U.S.A. (Elsewhere, an IBM office or representative will be happy to forward your comments or you may mail directly to the address in the Edition Notice on the back of the title page.)

Reader's Comment Form

Fold and tape

Please Do Not Staple

Fold and tape



NO POSTAGE
NECESSARY
IF MAILED
IN THE
UNITED STATES

BUSINESS REPLY MAIL
FIRST CLASS PERMIT NO. 40 ARMONK, N.Y.

POSTAGE WILL BE PAID BY ADDRESSEE

International Business Machines Corporation
Dept. E02
P.O. Box 12195
Research Triangle Park, N.C. 27709-9990



Fold and tape

Please Do Not Staple

Fold and tape





GA23-0214-3

Part Number
25F7651

File Number
36/38/370/4300/8100/3174-09

GA23-0214-03



Printed in U.S.A.