

IBM Maintenance Library

3278 Display Station Models 1, 2, 3, 4, and 5 Maintenance Information

Fifth Edition (September 1979)

This is a major revision of, and obsoletes, SY27-2510-3. This edition incorporates the changes made for the 3278 Display Station Model 5. Other, minor technical changes have been made throughout the manual. Figure 4-17 has been added. Changes are periodically made to the information herein. Such changes will be reported in subsequent revisions or Technical Newsletters.

It is possible that this material may contain reference to, or information about, IBM products (machines and programs), programming, or services that are not announced in your country. Such references or information must not be construed to mean that IBM intends to announce such IBM products, programming, or services in your country.

A form for readers' comments is provided at the back of this publication. If the form has been removed, address comments to IBM Corporation, Department 63T, Neighborhood Road, Kingston, N.Y. 12401. IBM may use or distribute any of the information you supply in any way it believes appropriate without incurring any obligation whatever. You may, of course, continue to use the information you supply.

©Copyright International Business Machines Corporation
1977, 1978, 1979

Preface

This publication contains the information needed to service and maintain the IBM 3278 Display Station. Part numbers for the usually needed field replaceable units (FRUs) are given in Chapter 4; keyboard assembly FRUs are given in paragraph 6.7 (Chapter 6). Additional parts-ordering information is contained in the *IBM 3278 Display Station Parts Catalog*, order number S126-0020.

Organization

This publication has seven chapters. Chapter 1 is a brief introduction to the 3278 and to the maintenance plan for the 3278. Chapter 2 contains the maintenance analysis procedures (MAPs). Chapters 3 through 7 contain reference material that supports the MAPs. Terms used throughout the publication are defined in the Glossary.

Starting Point

The starting point for all failure isolation on the 3278 is MAP 00, Start/Restart MAP.

Contents

Chapter 1. Introduction 1-1

- 1.1 General 1-1
 - 1.1.1 Electrical Grounding 1-3
 - 1.1.2 Equipment Lightning Protection 1-4
- 1.2 Maintenance Plan 1-5
- 1.3 Operation Tests 1-5
- 1.4 FRU Swapping 1-5
- 1.5 MAPs 1-5

Chapter 2. MAPs 2-1

- MAP 00, Start/Restart MAP 2-00-1
 - Symptom/Repair List 2-00-3
- MAP 01, Terminal Failure MAP 2-01-1
- MAP 02, Display MAP 2-02-1
- MAP 03, Keyboard MAP 2-03-1
- MAP 04, Feature Error MAP 2-04-1
- MAP 05, System Indicated Failure MAP 2-05-1

Chapter 3. Maintenance Aids 3-1

- 3.1 Introduction 3-1
- 3.2 Switches and Indicators 3-1
- 3.3 Operation Tests 3-1
 - 3.3.1 Offline Tests 3-1
 - 3.3.1.1 Test Mode 1 3-2
 - 3.3.1.2 Test Mode 2 3-6
 - 3.3.1.3 Test Mode 3 3-9
 - 3.3.2 Online Tests 3-19
 - 3.3.2.1 Requesting Online Tests 3-20
 - 3.3.2.2 Test 0, Display Operation 3-22
 - 3.3.2.3 Test 1, Error Log Display 3-26
 - 3.3.2.4 Error Log/Repair Action 3-30

Chapter 4. Locations (See Figures) 4-1

Chapter 5. Display Image Adjustments 5-1

- 5.1 Yoke Alignment and Centering 5-1
 - 5.1.1 Remove Cone Shield 5-1
 - 5.1.2 Yoke Alignment 5-1
 - 5.1.3 Centering and Horizontal Width 5-3
 - 5.1.4 Reinstall Cone Shield 5-3
- 5.2 Analog Card Adjustments 5-3
- 5.3 Focus Adjustment 5-4
- 5.4 +44 V Power Supply Adjustment Procedures 5-4

Chapter 6. Removals and Replacements 6-1

- 6.1 Covers 6-1
- 6.2 Power Units 6-1
 - 6.2.1 Low-Voltage Power Supply 6-1
 - 6.2.2 AC Capacitor 6-2
 - 6.2.3 Prime Power Box 6-2
 - 6.2.4 Ferrotransformer 6-2
 - 6.2.5 High-Voltage Power Supply 6-3
 - 6.2.6 Fuses 6-3
 - 6.2.7 Card/Connector Removal and Replacement Procedures 6-3

6.2.7.1	Internal Connectors	6-4
6.2.7.2	Internal Coax	6-4
6.2.7.3	Cards	6-4
6.2.8	Circuit Board Segments	6-5
6.3	CRT	6-5
6.4	Yoke and Shields	6-7
6.5	Operator Controls	6-8
6.5.1	CRT Frame Assembly	6-9
6.5.2	On/Off Switch	6-9
6.5.3	Intensity and Contrast Controls	6-9
6.5.4	Indicator Card Assembly	6-9
6.5.5	Switches	6-9
6.6	Optional Features	6-10
6.6.1	Audible Alarm	6-10
6.6.2	Security Keylock	6-10
6.7	Keyboard Units	6-10
6.7.1	Keyboard from Display Station	6-11
6.7.2	Keyboard Top Cover	6-11
6.7.3	Keyboard Assembly from Base	6-11
6.7.4	Clicker Assembly	6-12
6.7.5	Keybutton	6-12
6.7.6	Key Module	6-12
6.7.6.1	Key Module Removal (Including Spacer Module)	6-12
6.7.6.2	Key Module Replacement	6-13
6.7.7	Spacebar	6-14
6.7.8	Logic Card Assembly	6-14
6.8	Selector Pen	6-15
Chapter 7. Magnetic Slot Reader Information		7-1
Glossary		G-1

Figures

- 1-1 3278 Field Replaceable Units, (D) Type 1-1
- 1-2 3278 Field Replaceable Units, (M) Type 1-2
- 1-3 IBM 3276/3278 Problem Report Form 1-7
- 3-1 Test Patterns 3-3
- 3-2 Katakana Test Patterns 3-4
- 3-3 Japanese (English) Test Patterns 3-5
- 4-1 Switches and Indicators 4-1
- 4-2 Switches and Indicators (Katakana) 4-2
- 4-3 Lower Frame 4-3
- 4-4 Upper Frame 4-4
- 4-5 CRT and CRT Frame Assembly 4-5
- 4-6 Card Locations, (D) Type 4-6
- 4-7 Card Illustrations, (D) Type 4-7
- 4-8 Card Locations, (M) Type 4-8
- 4-9 Card Illustrations, (M) Type 4-9
- 4-10 Keyboard 4-10
- 4-11 Fuse Locations—Low-Voltage Power Supply 4-11
- 4-12 Prime Power and DC Voltage Distribution 4-12
- 4-13 Operator Controls 4-13
- 4-14 Operator Controls and Indicators 4-14
- 4-15 Feature Cabling 4-15
- 4-16 Logic Gate to Keyboard Cables 4-16
- 4-17 DC Power Distribution 4-17
- 5-1 CRT and High-Voltage Power Supply 5-2
- 5-2 Yoke Adjustments 5-2
- 5-3 Yoke Grounding Clips 5-2

CE SAFETY PRACTICES

All customer engineers are expected to take every safety precaution possible and to observe the following safety practices while maintaining IBM equipment:

1. You should not work alone under hazardous conditions or around equipment with dangerous voltage. Always advise your manager if you **MUST** work alone.
2. Remove all power, ac and dc, when removing or assembling major components, working in the immediate area of power supplies, performing mechanical inspection of power supplies, and installing changes in machine circuitry.
3. The wall box power switch, when turned off, should be locked or tagged in the off position. Affix "Do not Operate" tags, form 229-1266, when applicable. Pull the power supply cord whenever possible.
4. When it is absolutely necessary to work on equipment having exposed operating mechanical parts or exposed live electrical circuitry anywhere in the machine, the following precautions must be followed:
 - a. Another person familiar with power-off controls must be in the immediate vicinity.
 - b. Rings, wrist watches, chains, bracelets, and metal cuff links shall not be worn.
 - c. Only insulated pliers and screwdrivers shall be used.
 - d. Keep one hand in your pocket.
 - e. When using test instruments be certain that controls are set correctly and that proper-capacity insulated probes are used.
 - f. Avoid contacting ground potential (metal floor strips, machine frames, etc. — use suitable rubber mats purchased locally if necessary).
5. Safety glasses must be worn when:
 - a. Using a hammer to drive pins, riveting, staking, etc.
 - b. Power hand drilling, reaming, grinding, etc.
 - c. Using spring hooks, attaching springs.
 - d. Soldering, wire cutting, removing steel bands.
 - e. Parts cleaning, using solvents, sprays, cleaners, chemicals, etc.
 - f. Working under other conditions that may be hazardous to your eyes. **REMEMBER, THEY ARE YOUR EYES.**
6. Special safety instructions, such as handling cathode-ray tubes and extremely high voltages, must be followed as outlined in CEMs and Safety Section of the Maintenance Manuals.
7. Do not use solvents, chemicals, greases, or oils that have not been approved by IBM.
8. Avoid using test equipment or tools that have not been approved by IBM.
9. Replace worn or broken tools and test equipment.
10. The maximum load to be lifted is that which in your opinion and management's does not jeopardize your own health or well-being or that of other employees.
11. All safety devices such as guards, shields, signs, and ground wires shall be restored after maintenance.

12. Each customer engineer is responsible for being sure that no action on his part renders a product unsafe or exposes customer personnel to hazards.
13. Place removed machine covers in a safe out-of-the-way place where no one can trip over them.
14. All machine covers must be in place before the machine is returned to the customer.
15. Always place the CE tool kit away from walk areas, where no one can trip over it (for example, under a desk or a table).
16. Avoid touching mechanical moving parts (when lubricating, checking for play, etc.).
17. When using a stroboscope — do not touch ANYTHING — it may be moving.
18. Avoid wearing loose clothing that may be caught in machinery. Shirt sleeves must be left buttoned or rolled above the elbow.
19. Ties must be tucked in the shirt or fastened to it with a tie clasp (preferably nonconductive) approximately 3 inches from the end. Tie chains are not recommended.
20. Before starting equipment, make certain that fellow CEs and customer personnel are not in a hazardous position.
21. Maintain good housekeeping in area of machines while performing and after completing maintenance.

Artificial Respiration GENERAL CONSIDERATIONS

1. **Start Immediately, Seconds Count**
Do not move victim unless absolutely necessary to remove from danger. Do not wait or look for help or stop to loosen clothing, warm the victim, or apply stimulants.
2. **Check Mouth for Obstructions**
Remove foreign objects — Pull tongue forward.
3. **Loosen Clothing — Keep Warm**
Take care of these items after victim is breathing by himself or when help is available.
4. **Remain in Position**
After victim revives, be ready to resume respiration if necessary.
5. **Call a Doctor**
Have someone summon medical aid.
6. **Don't Give Up**
Continue without interruption until victim is breathing without help or is certainly dead.

Rescue Breathing for Adults Victim on His Back Immediately

1. Clear throat of water, food, or foreign matter.
2. Tilt head back to open air passage.
3. Lift jaw up to keep tongue out of air passage.
4. Pinch nostrils to prevent air leakage when you blow.
5. Blow until you see chest rise.
6. Remove your lips and allow lungs to empty.
7. Listen for snoring and gurglings, signs of throat obstruction.

8. Repeat mouth-to-mouth breathings 10-20 times a minute. Continue rescue breathing until victim breathes for himself.



Thumb and finger positions



Final mouth-to-mouth position

Reprint Courtesy Mine Safety Appliances Co.

Safety Notices

DANGER: All power unit removal and replacement procedures must be performed with power turned off and with the power cord disconnected.

DANGER: All persons touching a CRT or near a CRT that is not protected must have eye and arm protection.

DANGER: High voltage can be present when Indicator 2 is off.

DANGER: Safety glasses must be worn when the machines are being worked on with the power on and the covers off.

DANGER: Voltages are present in the heat sinks on the analog card when the power is on. Also, be careful when removing this card because the heat sinks will be hot (at high temperatures).

DANGER: Ferro capacitor 01D/C1 is grounded only when the capacitor is retained by its mounting spring.

The machine frame is grounded only when the prime power assembly 01D/A1 is mounted and fastened in place.

The ferrotransformer assembly 01D/T1 is grounded only when it is mounted and fastened in place.

Caution: The CRT weighs about 7.25 kg (16 pounds). Protect and support the CRT when removing and replacing it to prevent damage to the CRT and other units.

Caution: The 3278 must be off before cards and cables are reseated or swapped. Be careful not to loosen cards or cables when working on the 3278. This could cause intermittent failures then or at a later time.

Caution: The indicator above the ON/OFF switch is *not* a primary Power On indicator. Machine voltage may be present when this indicator is off.

Chapter 1: Introduction

1.1 General

The IBM 3278 Display Station must be attached to a port of the IBM 3274 Control Unit or of the IBM 3276 Control Unit Display Station (or other compatible controllers) by a coaxial cable. The 3278 contains field replaceable units (FRUs), as shown in Figures 1-1 and 1-2.

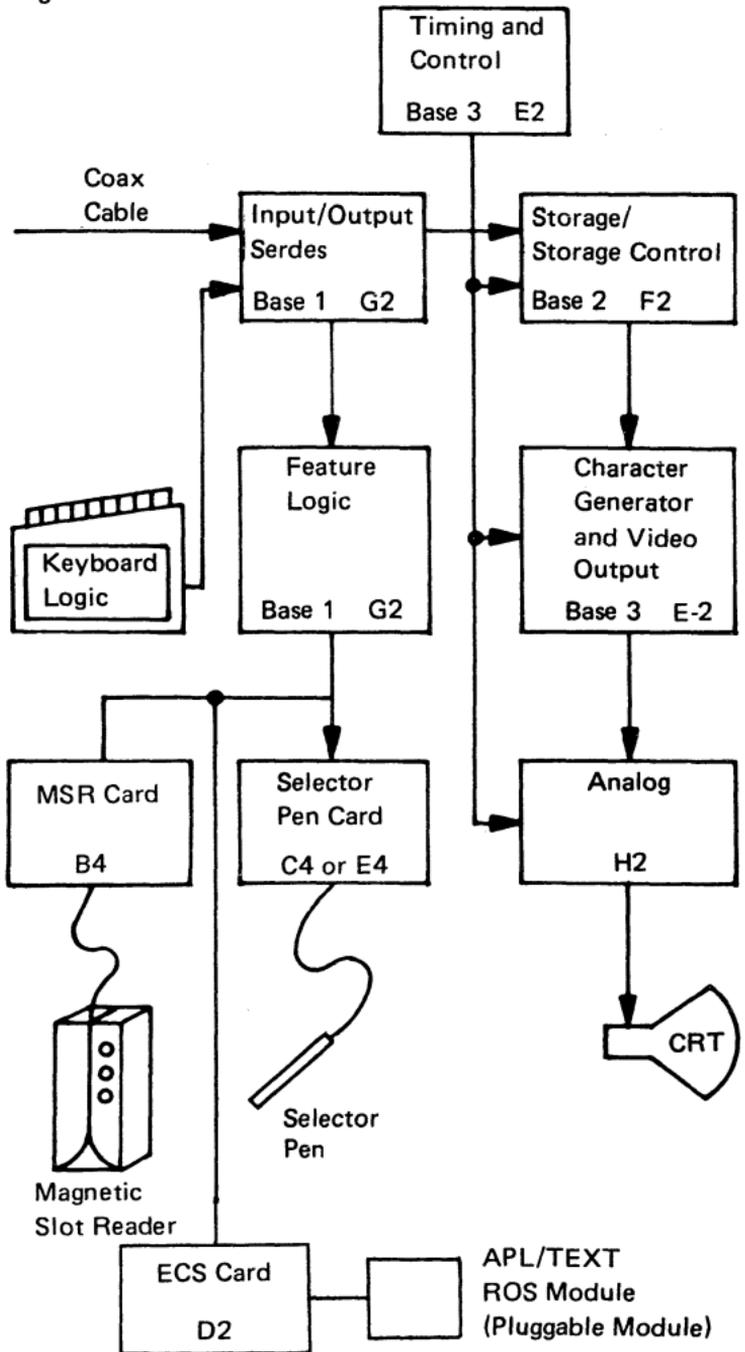

Figure 1-1. 3278 Field Replaceable Units, (D) Type

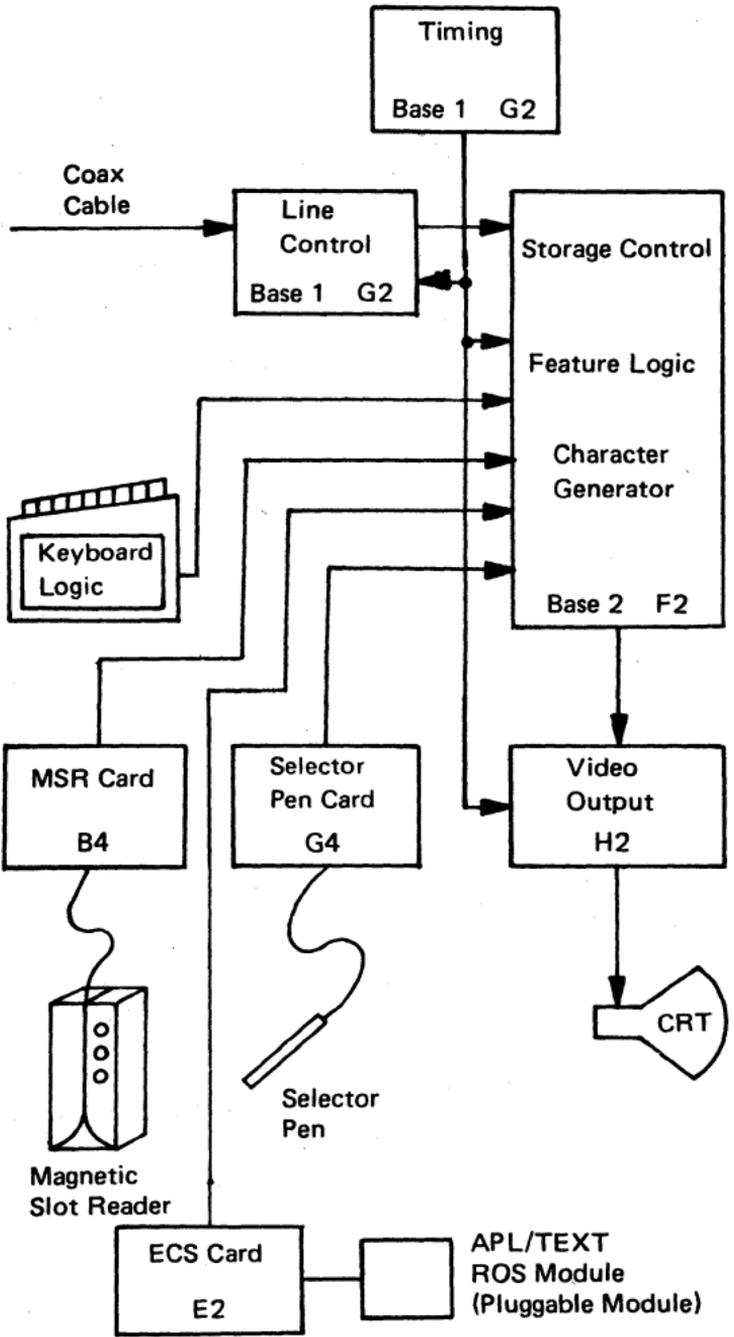

Figure 1-2. 3278 Field Replaceable Units, (M) Type

There are two configurations of the logic for the 3278 Display Station. The first is the (D) type, shown in Figures 1-1, 4-6, and 4-7. Three base logic cards are used in this configuration: base 1 (G2), base 2 (F2), and base 3 (E2). The second configuration, the (M) type, shown in Figures 1-2, 4-8, and 4-9, has two base cards: base 1 (G2) and base 2 (F2). Note the new locations of the feature cards when present with the second configuration.

The 3278 Display Station Model 5 has the (M) configuration only, and can display either an 80- or a 132-character line. The offline test describes the method for testing and aligning the Model 5.

The (D) type basic logic is packaged on three cards, one 2WX3H and two 4WX3H, and contains basic functions as follows:

Base card 1 – 01A/A1G02

Interface to coax, command decode and gates, and paths to features.

Base card 2 – 01A/A1F02

Storage, counters, and storage control.

Base card 3 – 01A/A1E02

Character generator, dot character line and row counters, video serializer, and control.

The (M) type base logic is packaged on two cards, one 2WX3H and the other 4WX3H. Most of the basic functions are contained in the 4W card, which is located at 01A/A1F2. The interface to the coax cable, the dot counter, and the video serializer are located on the card in 01A/A1G2.

1.1.1 Electrical Grounding

The 3278 is electrically connected between ac and dc returns at the unit. A ground wire is attached from the upper chassis to the gate and then to dc return at card location 01A/A1H2P8.

The coax return (shield) is isolated from the dc return at the 3278. With the ac power cord disconnected, a correctly wired unit should indicate continuity

between ac and dc ground, and an open circuit between the customer coax shield and the 3278 dc ground.

Major frame static points exist around the CRT area of the machine. Poor or no contact at these points may cause intermittent or erratic display operation such as:

- No display (blank screen)
- Erratic raster on the lower or the upper half of the screen
- A bright miniature raster in the center of the screen
- The high-voltage power supply cycling on and off
- A single line on the top of the screen

If the initial MAP procedures do not isolate the erratic display problem, check the following static ground points before retrying the MAPs.

- CRT harness (see Figure 4-5)
- Yoke shield and CRT connector (see Figure 5-1)
- Yoke/centering rings (see Figure 5-3)
- Contrast/intensity control (see Figure 4-5)
- Yoke grounding clips (see Figure 5-3)

The brightness-contrast assembly is grounded through a spring clip located behind the brightness assembly. Verify this connection by removing the brightness knob and checking for continuity between the frame and the brightness potentiometer shaft. (See Figure 4-5.)

Failure to maintain good grounding connections at all ground locations may cause erratic POR reset operation.

1.1.2 Equipment Lightning Protection

The 3278 is designed to provide a low-impedance energy path from the external coax shield to frame (ac) ground for potentials above 36 V. Additional information on lightning protection for the customer coax (customer responsibility) is provided in the *IBM 3270 Information Display System: Installation Manual—Physical Planning, GA27-2787*.

1.2 Maintenance Plan

The maintenance plan for the 3278 uses the following:

- Operation tests to sense failures, both for problem determination and for verification.
- FRU swapping as an aid to failure isolation.
- Maintenance analysis procedures (MAPs) to give a planned procedure to isolate and repair any failure on the 3278.

1.3 Operation Tests

Operation tests include offline and online tests.

- Offline tests (Test mode) – The 3278 offline tests are activated by placing the Normal/Test switch in the Test position, taking the 3278 offline from its control unit, and putting it in Test mode.
- Online tests— The 3278 online tests are in the control unit to which the 3278 is attached. Online tests may be requested from any online display station with a keyboard, and may be run on any specified online terminal attached to the same control unit. The results of the test are displayed at the requesting display station. Online tests include a routine to display the error log for any terminal attached to the same control unit, and for the control unit.

Operation tests are described in detail in Chapter 3.

1.4 FRU Swapping

The FRU swapping procedures are given in the MAPs in Chapter 2; FRU locations and part numbers, in Chapter 4.

1.5 MAPs

The MAPs are designed to give a quick and effective procedure for isolating and repairing any problem on the 3278. To use the MAPs effectively, you must observe the following rules:

1. Before the 3278 MAPs are used, the customer should have performed problem determination, using the *3278 Problem Determination Guide (PDG)*, located under the keyboard handrest.

2. If a failure was sensed while the 3278 PDG was being used, the failing step number was recorded on a problem report form [GX23-0201, or GX18-1033 for Japanese (English) or Katakana]; see Figure 1-3. This step number will be useful when the MAPs are being used.
3. If the failure is intermittent, cards and cable connectors should be checked for correct seating, and voltages should be checked for correct tolerances as described in MAP 01. Check the tightness of the screws on the capacitors in the low-voltage power supply.
4. The 3278 should be online to its control unit unless the MAP instructs you to place the 3278 offline. If the 3278 is offline (in Test mode), some of the symptoms may differ from those for which the MAPs were designed.
5. The MAPs will instruct you to reseat/swap cards in a specific sequence. The first card is the first probable cause of the failure, the next card is the next probable cause, etc.
6. Always reseat the cards and their associated cables, and test before swapping parts. Reseat the cables, and check the capacitor screws for tightness before swapping the low-voltage power supply.
7. When the analog card (card 01A-H2) is swapped, the new card may need adjustment.
8. Always reinstall the original part when the new part did not repair the problem.
9. If you go through the MAP once without repairing the problem, go back to the starting point and go through the MAP a second time. If, after a second pass through the MAPs, the trouble is not repaired, call for assistance.
10. The ECS card 01A/A1D02 (D) or 01A/A1E2 (M) may contain a pluggable APL/TEXT character generator ROS module. Static discharge can damage the ROS module if you do not follow proper grounding procedures when handling a loose module, that is, one not installed in a card socket. Hand contact should first be made to the foam or wrapping in which

IBM 3276/3278 Problem Report Form

Unit Identification	_____
Unit Location	_____
Unit Type 3276 3278 (circle one)	_____
Unit Serial Number	_____
Telephone Number	_____
Date and Time	_____
Reported by	_____

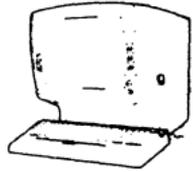

1 Record the step number where you detected the failure:

Step Number: _____

2 Circle all of the following symbols that are displayed in the Operator Information Area of the failing display station(s):

Note: If not a or a , record the symbol.

Subsystem Ready or _____

Host Connection or _____

Communication Problem _____

Display Station Problem _____

Program Error _____ PROG _____

If one of these three symbols is displayed, insert the 2- or 3-digit code following the symbol.

3 If the display station is a 3278, go to step 8; if the display station is a 3276, continue.

4 Are all attached terminals failing?

If "NO" is checked, identify all the failing terminals:

YES NO

5 Write an "X" in each circle below for each light that was on when the error occurred.

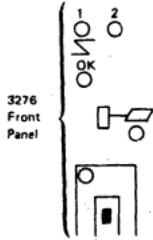

Inside of 3276 Control Drawer

System Check Machine Check Test

6 If the keyboard is failing, fill in the appropriate section below. On the keyboard diagram below write an X in the appropriate location for each key that failed.

- All keys fail.
- All character keys fail.

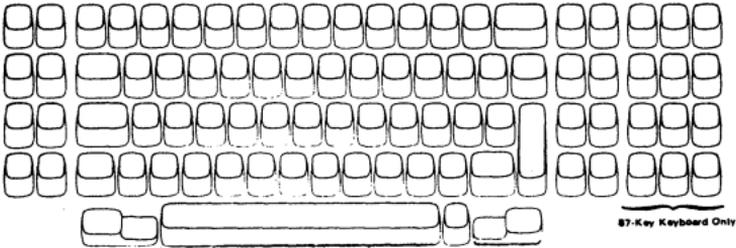

7 After completing this form, follow your organization's procedure for reporting problems and save this form for the service representative.

International Business Machines Corporation
Data Processing Division
1123 Westchester Avenue, White Plains, N.Y. 10604
IBM World Trade America/Far East Corporation
Times of Square Plaza, Route 9, North Tarrytown, N.Y. U.S.A. 10591
IBM World Trade Europe/Middle East/Africa Corporation
380 Hamilton Avenue, White Plains, N.Y. U.S.A. 10601

Address comments concerning this form to IBM Corporation,
Department 63T, Neighborhood Road, Kingston, New York 12401
© Copyright International Business Machines Corporation 1978, 1979

Printed in the U.S.A. GX23-0201-2 3/79

Figure 1-3. IBM 3276/3278 Problem Report Form

the module is packed. Also, while holding a module to be installed in a socket, first make hand contact to the socket pins to drain off any static charge.

11. Terminals that have the ECS feature, card location 01A/A1D02 (D), will have the selector pen card in location 01A/A1E4. All references to the selector pen card for the (D) type will be location 01A/A1C04 or 01A/A1E4.

Caution: The 3278 must be off before you reseal or swap cards and cables. Be careful not to loosen cards or cables when working on the 3278. This could cause intermittent failures then or at a later time.

Chapter 2. MAPs

MAP 00, Start/Restart MAP

Start here to isolate any failure on the 3278 Display Station.

Note: *The two different logic types used in the 3278 are indicated by (M) and (D): (M) indicates the logic using two base cards (Figures 1-2 and 4-8); (D) indicates the logic using three base cards (Figures 1-1 and 4-6). Throughout the MAPs an (M) or a (D) will follow the card callouts to indicate in which logic the problem card is located. Where neither (M) nor (D) is indicated, the card is the same for both logic types.*

001

(Entry Point A)

Is this the first time through this MAP ?

(Highly intermittent or not failing now; take NO leg.)

Y N

Use the Error Log and Error Code to FRU list (par. 3.3.2.3); use the Symptom/Repair List to aid you in developing your action plan.

A few examples are:

1. Swap suspected FRU; for example, if 3276 log shows 41 and 77 errors, swap A-G2 for isolation.
2. Request a Retain Data Bank/EWS Search (based on logged error codes, gathered data, and your observation of the problem).
3. Check voltages for proper levels and/or ripple. (See Figure 4-11; all voltages are $\pm 10\%$.) See par. 5.4 for 44 V adjustment.
4. Check the ferrocapacitor for proper operation by doing the following:
 - a. Switch off the unit.
 - b. Discharge the capacitor by performing steps 1, 2, and 3, from par. 6.2.2.

Note: *Exchange the capacitor if it is distorted from internal pressure.*
 - c. Set the CE meter to the R x 1K scale.

2
A

A
1

- d. Touch the test leads of the CE meter across the capacitor terminals; the meter should momentarily deflect. Reverse the meter test leads; the meter should deflect again. If there is no meter deflection, exchange the ferrocapacitor.
5. Check coax connectors and electrical grounding as described in par. 1.1.1.
6. Contact FSC/Branch Support for assistance.

002

Is one or more light-emitting diode (LED) "off" (3 LEDs to left of screen)?

Y N

003

Is card kit or FRUs available for swapping?

Y N

| Go to MAP 01-001 Entry Point A.

004

Use Symptom/Repair List or go to MAP 01-001 Entry Point A as experience dictates.

005

Go to MAP 01-001 Entry Point A.

SYMPTOM/REPAIR LIST

Symptom	Action
	<ul style="list-style-type: none">• Reseat/swap cards called out in this column.• Swap/adjust card A1H2 where called out.• All logic cards are in the 01A gate.
1. Display blank (no cursor, divider line, or light on screen):	Hold the intensity control fully clockwise (Test position), and check for symptoms a, b, c, and ##.
a. Normal raster or raster on upper or lower half of screen	(D) A1E2 A1F2
b. Single line or glow at top of screen	(D) A1G2 A1E2 A1F2 A1H2
c. No raster	Check fuse 1 on the low-voltage power supply. Swap the high-voltage power supply. A1H2 Swap/adjust the CRT yoke.
2. Display dim at maximum intensity, or raster visible at minimum intensity.	Check analog card adjustment (raster blanking). A1H2 Check intensity potentiometer and cables. (See Figure 4-13.)
3. Displays single line at top or center of screen, or data only on bottom half of screen.	A1H2 A1F2 Swap/adjust the CRT yoke.
4. Displays widely spaced diagonal lines or is out of sync (moving or vibrating screen).	(D) A1E2 A1F2 A1H2

Symptom	Action
5. Displays full raster with intensity set to normal (cursor may also display); or each character position displays the full character space.	(D) A1E2 A1H2 A1F2
6. Displays one of the following: <ul style="list-style-type: none"> • Divider Line only • Divider Line and a line at bottom of screen • Random data after power on • Test pattern when online 	A1F2 A1G2
7. Cursor flashes at random locations.	A1G2 A1F2
8. Display size changes when intensity is changed.	Reseat/swap the high-voltage power supply. (See par. 6.2.5.)
9. Display tilted or incorrect size.	Adjust the yoke or analog card potentiometers. (See par. 5.1.)
10. Cursor missing, will not blink or reverse.	Verify with the Normal/Test switch in the Test position. Check the analog card adjustment (see Chapter 5). A1F2 (D) A1E2 A1G2
11. Normal/Test switch operation failure.	A1G2 A1H2 Check the switch and cables. (See Figure 4-13.)
12. Monocase (A, a/A) switch operation failure.	(D) A1E2 A1G2 Check the switch and cables. (See Figure 4-13.)

Symptom	Action
13. Incorrect characters display and Device Check is indicated (Machine Check =X 77).	A1G2 A1F2
14. Incorrect characters display without Device Check; or extra or missing dots on screen. If in APL/TEXT mode only	(D) A1E2 A1G2 A1F2 Reseat/swap ROS module in 01A/A1D2 (D) or 01A/A1E2 (M) (D) A1D2 or (M) A1E2
15. Test Mode 1 characters incorrect on half or all of the screen, or in incorrect sequence.	(D) A1G2 A1E2 A1F2
16. Will not change row length (Model 5 only).	A1F2 A1H2
17. Keyboard not working, input inhibit not indicated. Characters do not enter.	(D) A1G2 (M) A1F2 Set the Normal/Test switch to the Test position, and try to enter from the keyboard. If you cannot enter, swap the keyboard logic card. Verify keyboard cables (Figure 4-16).
18. One keyboard key fails.	Set the Normal/Test switch to the Test position, and check the code for the failing key. (See par. 3.3.1.2, Test Mode 2.) If the character is incorrect, swap the keyboard logic card. (See Chapter 6.) If the character is correct, check the keyboard ID jumpers. (See Figure 4-10.) If the jumpers are correct, swap

Symptom**Action**

19. Incorrect characters enter from keyboard.

the keyboard logic card.

(D) A1G2

(M) A1F2

Reseat/swap the keyboard logic card. Check the keyboard/PC mounting screws. Check the keyboard cables. (See Figure 4-16.)

20. 3278 cannot be logged online.

Check:

- Run L Test 0 (AA/0) to enable
- Security Key on (clockwise)
- Normal/Test switch in Normal position
- Coaxial cable connector seated

A1G2

A1F2

(D) A1E2

Go to Entry Point A, MAP 05.

21. Selector-pen failures.

(D) A1C4

(D) A1E4

(M) A1G4

Reseat/swap the selector pen.

A1G2

A1F2

22. MSR failures.

A1B4

A1G2

Reseat/swap the MSR.

23. Error Codes Indicated.

See par. 3.3.2.3, Error Log/Repair Action.

24. APL/TEXT mode errors.

(D) A1D02

A1G02

(M) A1E2

MAP 01

Terminal Failure MAP

PAGE 1 OF 13

ENTRY POINTS

FROM	ENTER THIS MAP		
MAP NUMBER	ENTRY POINT	PAGE NUMBER	STEP NUMBER
00	A	1	001

EXIT POINTS

EXIT THIS MAP		TO	
PAGE NUMBER	STEP NUMBER	MAP NUMBER	ENTRY POINT
2	007	00	A
3	011	02	A
2	010	03	A
2	009	04	A
2	008	05	A
3	012	05	A

001

NOTE: If the 01A/A1H2 card is exchanged the adjustments must be verified. It is possible for an adjustment to be in a position that may appear to be a failure. Test mode 1 can be used to verify that the 01A/A1H2 card is correctly adjusted for width, height and raster blanking. See Adj. Section 5.2.

(Entry Point A)

Is one or more light emitting diodes (lights 1,2 and 3) 'OFF' or very dim?

Y N

002

Is there an error code displayed for this failure? (See 3.3.2.3 for applicable codes)

Y N

3 3 2
A B C

C
I

MAP 01

Terminal Failure MAP

PAGE 2 OF 13

003

(A normal display is - cursor, divider line, indicators and/or system written data as expected.)

Is there an **INCORRECT** display?

Y N

004

Is this a **Keyboard** failure? (Exercise keyboard in test mode, use Y path if results are unexpected)

Y N

005

Is this a **Feature** failure? (Does not include keyboard)

Y N

006

Is this a **subsystem indicated** failure (error code displayed or failures not detected by off line tests 1, 2 or 3.)?

Y N

007

Use test mode procedure (section 3.3.1), to identify problem.

Go To Map 00, Entry Point A.

008

Go To Map 05, Entry Point A.

009

Go To Map 04, Entry Point A.

010

Go To Map 03, Entry Point A.

3
D

A B D
1 1 2

MAP 01

Terminal Failure MAP

PAGE 3 OF 13

011

Go To Map 02, Entry Point A.

012

Go To Map 05, Entry Point A.

013

Is light 3 above power ON/OFF switch on? (If very dim use N path.) See Fig 4-1, 2 for location)

Y N

014

Verify that the power on switch is on, line power cable plugged in an active outlet and seated at the primary power box.

Are above conditions correct?

Y N

015

Correct and verify.

016

Switch unit off.

Verify Fuse F1 in main power box (Figure 4-3).

Did fuse fail?

Y N

017

Verify low voltage supply fuses (F2, F3, F5, F6).

(See fuse locator Figure 4-11).

Are all fuses good?

Y N

1 1 5 4
E F G H

H
3

MAP 01

Terminal Failure MAP

PAGE 4 OF 13

018

Exchange failing fuse or fuses.
Switch Unit On. (Wait 30 sec.)
Did fuse or fuses fail again?

Y N

019

Verify correct operation.
If problem occurs again start over at Entry Point
A of this MAP to identify new symptom.

020

Switch unit off.
Remove 01A/A1H2 card and exchange fuse(s).
Switch Unit On.
Did fuse(s) fail again?

Y N

021

Switch unit off.
Exchange 01A/A1H2 card and adjust.
If fuse fails after new 01A/A1H2 card is
installed problem can be in high voltage power
supply or yoke.
Remove connector on high voltage power supply
and yoke to isolate.

022

Switch unit off.
Short is in Low voltage power cable logic cards or
keyboard. Reinstall 01A/A1H2 removed in step
20.
Remove logic cards and keyboard cable.
Exchange failing fuse and switch unit on.
Did fuse fail again?

Y N

5 5
J K

G J K
3 4 4

MAP 01

Terminal Failure MAP

PAGE 5 OF 13

023

Exchange logic cards one at a time in the following sequence; 01A/A1G2, F2, E2 (D), or 01A/A1F2, G2 (M).

Switch unit off and ON for each exchange. (Permit 30 sec. for power to be on each time).

If fuse does fail after a card is reinstalled, exchange that card with a new card and start over.

If fuse does not fail when all the logic cards are reinstalled, reconnect keyboard cable. If reinstalling the keyboard cable causes the fuse to fail exchange the keyboard logic card. Should exchanging of the keyboard card not repair the problem the keyboard should be exchanged.

024

Repair or exchange the Low Voltage cable. See Figure 4-12 for wiring figure.

025

Remove Line Power cable from power outlet.

Switch Unit On switch to ON and measure resistance across pins of line power cable plug.

(This is a continuity test of the line power cable, main power box, power switch, ferro primary and fuse F1 in the main power box, normal is less than 5 ohms.)

Measures 5 ohms or more?

Y N

9 6
L M

M
5

MAP 01

Terminal Failure MAP

PAGE 6 OF 13

026

Plug line power cable in and switch unit on.
Verify voltage at J4 on the low voltage power supply between pins 1 and 4 for 48 volts AC. (See Figure 4-11).

Is the voltage correct?

Y N

027

Reverify power source outlet. If outlet is good, exchange ferro.

028

Verify DC voltages:

(DC Common is at C3 - (minus) on low voltage power supply

(Voltages are $\pm 10\%$ except +8)(See Figure 4-11)

+5 at fuse F6.

+8.5 at fuse F3.

+44 at fuse F5.

-5 at 01D/PS1-J3-3.

-12 across C1 (F2).

-44 at 01D/PS1-J3-1.

+8V \pm 1volt 01D/PS1-J2-2,
(derived from +8.5V supply).

Are all voltages correct?

Y N

029

Switch unit off.

Remove analog card.

Switch unit on.

Verify voltages as shown in preceding step.

Is one or more voltages incorrect?

Y N

9 7 7
N P Q

P 0
6 6

MAP 01

Terminal Failure MAP

PAGE 7 OF 13

030

Switch power off.
Exchange analog card 01A/A1H2.
Switch unit on.
Adjust as required (see 5.2).
Test for proper operation.

031

Is the -44 volts incorrect?

Y N

032

Switch unit off.
Disconnect keyboard cable at 01A/A1G5 (D) or
01A/A1F5 (M).
Switch power on.
Verify failing voltage.

Is voltage still incorrect?

Y N

033

Replace keyboard logic card and/or keyboard
cable/cables as required.
Reinsert analog card in 01A/A1H2.
Switch power on.
Test for proper operation. Return to
customer.

034

Switch power off.
Remove all logic cards.
Switch unit on.
Is voltage still incorrect?

Y N

8 8 8
R S T

R S T
7 7 7

MAP 01

Terminal Failure MAP

PAGE 8 OF 13

035

Switch unit off.

Reinsert logic cards one at a time to isolate failing card.

036

Switch unit off.

Exchange low voltage power supply.

Reinsert logic cards, keyboard cable and analog card.

Switch power on.

Test for proper operation.

037

Switch power off.

Remove mask assembly (see 6.5).

Disconnect 01C/A1P1 from 01C/A1J1 (See Fig. 4-5).

Switch unit on.

Verify -44 volts at 01D/PS1-J3-1.

Is voltage still incorrect?

Y N

038

Exchange Intensity/Contrast Control (see 6.5.3).

Reinsert analog card, 01C/A1P1 and mask assembly.

Switch power on.

Test for proper operation.

039

Verify seating of connectors on low voltage power supply. If all connectors are seated but problem is still present exchange Low Voltage power supply.

Switch Unit On and test for proper operation.

L N
5 6

MAP 01

Terminal Failure MAP

PAGE 9 OF 13

040

Verify seating of the power distribution cable at the low voltage power supply (P2 and P3) and at the logic gate. If reseating the connectors does not correct the problem, verify the DC voltages at the logic gate. See Figure 4-12.

Exchange the 01A/A1H2 card, adjust and test for proper operation.

041

Remove line power cable from main power box(P1).

Verify resistance from pin B to pin C of line power cable socket (J1) (See Figure 4-12).

Measures 5 ohms or more?

Y N

042

Exchange line power cable and test for correct operation.

043

Remove plug P3 from J3 on main power box.

Verify resistance from pin 1 to pin 3 on P3 (Ferro Primary verify).

Measures 5 ohms or more?

Y N

044

Remove Plug P2 from J2 on main power box.

Test for 1 ohm or less between pins 2 and 3 then between pins 1 and 4 on P2. (Test of main power switch). (See Figure 4-12)

Measures 1 ohm or less for both tests?

Y N

1 1 1
0 0 0
U V W

F U V W
3 9 9 9

MAP 01

Terminal Failure MAP

PAGE 10 OF 13

045

Exchange ON/OFF switch.
Reinsert previously removed plugs.
Reconnect in terminal and test for proper operation.

046

Exchange prime power asm. (Figure. 4-3).
Test for proper operation.

047

Exchange Ferro Transformer.
Verify correct operation.

048

Exchange fuse F1 in main power box.
Switch Unit On and wait up to 30 sec.
Did fuse fail again?

Y N

049

Verify correct operation.

050

Switch unit off.
Remove plug P3 from J3 on main power box.
Exchange fuse.
Switch Unit On.
Did fuse fail again?

Y N

1 1
1 1
X Y

E X Y
3 1 1
0 0

MAP 01
Terminal Failure MAP
PAGE 11 OF 13

051
Switch unit off.
Reconnect P3 to J3 on main power box.
Remove plugs from J1 and J4 on low voltage power supply. (See Figure 4-11)
Switch Unit On.

Did fuse F1 fail again?
Y N

052
Exchange low voltage power supply.
Verify correct operation.

053
Exchange ferro transformer.
Verify correct operation.

054
Exchange main power box.
Reconnect and verify correct operation.

055
Is light 1 (Sweep Indicator) (LED#1) ON? (Use N path if very dim)
Y N

056
Switch unit off.
Exchange the 01A/A1H2 card.
Switch Unit On, adjust and verify correct operation.

1
2
Z

Z

MAP 01

Terminal Failure MAP

PAGE 12 OF 13

057

Is light 2 (High Voltage Indicator) ON, or very dim?

See Fig 4-1, 2 for location).

DANGER

High Voltage can be present when the High Voltage Indicator is OFF

Y N

058

Switch unit off.

Exchange the High Voltage power supply.

Switch Unit On and verify correct operation.

Is light 2 ON?

Y N

059

Switch unit off.

Exchange and adjust the 01A/A1H2 card.

Verify correct operation.

If the problem remains, exchange low voltage power supply, yoke.

060

Verify correct operation.

061

Is light 2 very dim?

Y N

062

Start over at MAP 00 Entry Point A if first time through MAP.

1

3

A

A

09
10
11
12
13
14
15
16
17
18
19
20
21
22
23
24
25
26
27
28
29
30
31
32
33
34
35
36
37
38
39
40
41
42
43
44
45
46
47
48
49
50
51
52
53
54
55
56
57
58
59
60
61
62
63
64
65
66
67
68
69
70
71
72
73
74
75
76
77
78
79
80
81
82
83
84
85
86
87
88
89
90
91
92
93
94
95
96
97
98
99
100

A
A
1
2

MAP 01
Terminal Failure MAP
PAGE 13 OF 13

063
Exchange and adjust card 01A/A1H2.
Verify correct operation.

MAP 02

Display MAP

PAGE 1 OF 19

ENTRY POINTS

FROM	ENTER THIS MAP		
MAP NUMBER	ENTRY POINT	PAGE NUMBER	STEP NUMBER
02	A	1	001
02	B	5	028
02	C	11	066
02	D	15	088

EXIT POINTS

EXIT THIS MAP		TO	
PAGE NUMBER	STEP NUMBER	MAP NUMBER	ENTRY POINT
1	002	01	A
18	108	03	A
1	004	04	A
19	113	05	A

001

(Entry Point A)

Are all three lights (#1, 2 and 3. See Fig 4-1 for location) on?

Y N

002

Go To Map 01, Entry Point A.

003

Remove feature cards if present.

Is problem still present?

Y N

004

Go To Map 04, Entry Point A.

2
A

A
↑

MAP 02

Display MAP

PAGE 2 OF 19

005

Disconnect coax signal cable at 01S1/J4 (Figure 4-4). Set TEST/NORMAL switch to TEST then to NORMAL.

Is there a normal Cursor or normal divider line displayed on the screen? (Use N path if no display or raster on screen or flashing on and off or erratic.)

Y N

006

Is there a normal divider line on the screen?

Y N

007

Go to Page 5, Step 028, Entry Point B.

008

Is there a normal cursor on the screen?

Y N

009

Go to Page 11, Step 066, Entry Point C.

010

Is the screen blank? (No light) (Use N path if flashing or erratic.)

Y N

011

Does the intensity control affect the light on the screen?

Y N

9 5 3 3
B C D E

D E
2 2

MAP 02

Display MAP

PAGE 3 OF 19

012

Exchange and adjust the 01A/A1H2 card.

Is the problem still present?

Y N

013

Reconnect coax signal cable, feature card(s).

Verify correct operation.

Identify new problem if present.

014

Verify the following:

1. Cable and connectors from analog card to CRT base socket (Figure 4-14).
2. Cable and connectors from analog card to intensity control potentiometer (Figure 4-13).
3. Intensity control potentiometer.
4. Intensity override switch (Spring loaded).
5. Possible short circuited CRT
6. Reconnect coax signal cable, feature card(s).

015

Is the display on the screen normal? (Good characters, in focus and normal size. Use intensity override if necessary to determine size and condition of raster)

Y N

016

Is display size or focus a problem? (Use N path if raster problem)

Y N

017

Go to Page 5, Step 028, Entry Point B.

4 4
F G

F G
3 3

MAP 02

Display MAP

PAGE 4 OF 19

018

Use analog adjustment procedure to verify correct adjustment of 01A/A1H2 card and focus of high voltage power supply.

Is problem still there after verifying analog adjustments? (Chapter 5.2)

Y N

019

Reconnect coax signal cable, feature card(s).
Verify correct operation.

020

Exchange and adjust 01A/A1H2 card.

Problem still there?

Y N

021

Reconnect coax signal cable, feature card(s).
Test for proper operation.

022

Exchange High Voltage power supply.
Reconnect coax signal cable, feature card(s).
Verify correct operation.

023

Is the display flashing on and off?

Y N

024

Exchange the 01A/A1H2, E2, F2, G2 (D), or 01A/A1H2, F2, G2 (M) cards one at a time.
Reconnect coax signal cable, feature card(s).
Verify correct operation.

5
H

C H
2 4

MAP 02

Display MAP

PAGE 5 OF 19

025

Hold intensity control in override position.

Does raster flash off and on?

Y N

026

Exchange cards 01A/A1F2, 01A/A1E2 (D),
or 01A/A1G2, F2 (M).

Reconnect coax signal cable, feature card(s).

Test for proper operation.

027

Exchange High Voltage power supply.

Reconnect coax signal cable, feature card(s).

Verify correct operation.

028

(Entry Point B)

Use the intensity override control to force a display
on the screen.

**Does the screen have a raster displayed with
override ON?**

Y N

029

Is the screen blank?

Y N

030

Exchange logic card 01A/A1E2 (D), or
01A/A1F2 (M).

Is problem still present?

Y N

8 6 6 6
J K L M

K L M
5 5 5

MAP 02

Display MAP

PAGE 6 OF 19

031

Reconnect coax signal cable, feature card(s).
Test for proper operation.

032

Exchange and adjust 01A/A1H2 card.
Reconnect coax signal cable, feature card(s).
Test for proper operation.

033

Exchange and adjust the 01A/A1H2 card.
Is problem still present?

Y N

034

Reconnect coax signal cable, feature card(s).
Test for proper operation.

035

Observe the neck of the CRT to see if a light from
the filament is visible. (Remove cone shield on
neck of CRT if necessary. Chapter 5.1.1)

Is there a light?

Y N

036

Switch unit off.
Verify fuse F1 on low voltage power supply.
Is fuse good?

Y N

037

Exchange fuse (1A SB) and switch unit on.
Did fuse fail again? (permit 30 sec.)

Y N

8 8 7 7
N P Q R

Q R
6 6

MAP 02

Display MAP

PAGE 7 OF 19

038

Reconnect coax signal cable, feature card(s).
Verify correct operation.

039

Switch unit off.
Remove socket from CRT.
Exchange fuse.
Switch Unit On.
Does fuse fail again?

Y N

040

Exchange CRT. Do alignment procedure,
Reconnect coax signal cable, feature card(s).
Verify correct operation.

041

Test for short in cable from Low Voltage power supply to CRT socket (Remove plug J2 from Low Voltage power supply and test for short between pins 1 and 14 at the CRT socket). Repair or exchange as needed.
Reconnect coax signal cable, feature card(s).
Verify correct operation.

J N P
5 6 6

MAP 02

Display MAP

PAGE 8 OF 19

042

Remove and verify the connections at the CRT socket.

Measure resistance on pins 1 and 14 at CRT base.

If more than 5 ohms exchange CRT.

If less than 5 ohms verify cable and connections from Low Voltage power supply to CRT socket. (See Figure 4-14.

Test for an open wire from J2-3 to CRT socket pin 1 and for an open between J2-9 to CRT socket pin 14. (Figure 4-12)

Repair or exchange cable if open.

If cable tests good exchange the CRT.

Reconnect coax signal cable, feature card(s).

Verify correct operation.

043

Exchange the High Voltage power supply.

Reconnect coax signal cable, feature card(s).

Verify correct operation.

044

Does raster appear normal? (Covers full display area)

Y N

045

Is there a single line at or near the top of the screen?

Y N

9 9 9
S T U

B S T U
2 8 8 8

MAP 02

Display MAP

PAGE 9 OF 19

046

(Raster abnormal and/or on lower part of screen only.)

Exchange one at a time, card 01A/A1E2, G2, F2, H2 (D), or 01A/A1F2, G2, H2 (M).

Reconnect coax signal cable, feature card(s).

Verify correct operation.

047

Exchange 01A/A1H2, F2, E2 (D), or 01A/A1H2, G2, F2 (M) card.

Reconnect coax signal cable, feature card(s).

Verify correct operation.

048

Exchange 01A/A1G2, F2 card (D) or 01A/A1F2, G2 (M).

Is problem still present?

Y N

049

Reconnect coax signal cable, feature card(s).

Verify correct operation.

050

Exchange the 01A/A1H2 card and adjust.

Reconnect coax signal cable, feature card(s).

Verify correct operation.

051

Is there a cursor on the screen?

Y N

052

Go to Page 11, Step 066, Entry Point C.

1
0
V

V
9

MAP 02

Display MAP

PAGE 10 OF 19

053

Is there a divider line on the screen?

Y N

054

Go to Page 5, Step 028, Entry Point B.

055

Is the divider line near the bottom of the screen?

Y N

056

Go to Page 5, Step 028, Entry Point B.

057

Verify position of the security key for ON (Full clockwise) if feature is installed.

Was the security key in the correct position? (If the security key is not installed use the Y path.)

Y N

058

Switch key to ON (Full clockwise).

Has the problem been corrected?

Y N

059

Verify wiring to the security key and key switch.

Repair or exchange (See Figure 4-14).

Reconnect coax signal cable, feature card(s).

Verify correct operation.

060

Reconnect coax signal cable, feature card(s).

End of call.

1
1
W

MAP 02

Display MAP

PAGE 11 OF 19

W
1
0

061

Does the cursor appear normal?

Y N

062

Is there a divider line near the bottom of the screen?

Y N

063

Exchange 01A/A1G2 card.
Reconnect coax signal cable, feature card(s).
Test for proper operation.

Problem still present?

Y N

064

End of call.

065

Exchange 01A/A1H2 card and adjust.
Test for proper operation.

066

(Entry Point C)

Put the Test/Normal switch in the Test position.
Is the test pattern displayed and does the cursor appear to be a bar under the first character at top left of the screen?

Y N

1 1 1
3 3 2
X Y Z

Z
1
1

MAP 02

Display MAP

PAGE 12 OF 19

067

Press 'Reset' key one time. (Test Mode 3).

Press 'K' key.

Press ',' key.

Is there a reverse flashing cursor on the screen?

Y N

068

Is the test pattern correct except for cursor?

Y N

069

Is the display correctly adjusted?

Y N

070

Use adjustment procedure for 01A/A1H2 card and yoke. (Chapter 5.2).

Reconnect coax signal cable, feature card(s).

Verify correct operation.

071

Exchange 01A/A1F2, E2, or G2 (D), or 01A/A1F2, G2 card (M).

Reconnect coax signal cable, feature card(s).

Verify correct operation.

072

Exchange 01A/A1G2, F2 (D), or 01A/A1G2, F2 card (M).

Reconnect coax signal cable, feature card(s).

Verify correct operation.

1
3
A
A

X Y A
1 1 1
1 1 2

MAP 02

Display MAP

PAGE 13 OF 19

073

Exchange 01A/A1G2, F2, or E2 card (D), or 01A/A1G2, F2 card (M).
Reconnect coax signal cable, feature card(s).
Verify correct operation.

074

The cursor was inhibited or placed off the screen by the controller. Verify controller failure by swapping coax cables with another terminal to ensure that the problem follows.

075

Is the cursor and divider line the only display on the screen?

Y N

076

Is the Test Pattern displayed?

Y N

077

Exchange cards 01A/A1G2, F2, E2 (D), or 01A/A1G2, F2 (M) one at a time to isolate bad card.
Reconnect coax signal cable, feature card(s).
Verify correct operation.

078

Go to Page 15, Step 088, Entry Point D.

079

Does the display alignment and focus appear correct? (Position, size). Use test mode 1 to verify.

Y N

1 1
4 4
A A
B C

A A
B C
1 1
3 3

MAP 02

Display MAP

PAGE 14 OF 19

080

Use the adjustment procedure to correct alignment or focus of the display. If the problem cannot be corrected by adjustment exchange the 01A/A1H2 card, high voltage power supply.

Reconnect coax signal cable, feature card(s).
Verify correct operation.

081

Does the intensity and contrast control work correctly?

Y N

082

Exchange 01A/A1H2, 01A/A1F2 card.

Has the problem been corrected?

Y N

083

Use Figure 4-13 to isolate problem to the cable, connector or intensity/contrast assembly.

Repair or exchange.

Reconnect coax signal cable, feature card(s).
Verify correct operation.

084

Adjust 01A/A1H2 card.

Reconnect coax signal cable, feature card(s).
Verify correct operation.

1
5
A
D

A
D
1
4

MAP 02

Display MAP

PAGE 15 OF 19

085

Does the Test/Normal switch cause the Test Pattern to be displayed when in Test position only?

Y N

086

Exchange cards 01A/A1G2, 01A/A1F2, 01A/A1E2 (D), or 01A/A1G2, F2 (M).

Is problem still present?

Y N

087

Reconnect coax signal cable, feature card(s).
Verify correct operation.

088

(Entry Point D)

See Figure 4-13 to verify switch and cable to logic.

Repair or exchange.

Reconnect coax signal cable, feature card(s).

Verify correct operation.

089

Put the Test/Normal switch in Test position.

Is test pattern 1 correct? (See 3.3.1).

Y N

090

Is there a cursor, divider line or any characters on the screen?

Y N

1 1 1
8 6 6
A A A
E F G

A A
F G
1 1
5 5

MAP 02

Display MAP

PAGE 16 OF 19

091

Exchange 01A/A1G2 (D), or 01A/A1F2, G2 card (M).

Reconnect coax signal cable, feature card(s).
Verify correct operation.

092

Are displayed characters readable but some/all missing or wrong?

Y N

093

Exchange 01A/A1G2 (D), or 01A/A1G2, F2 card (M).

Reconnect coax signal cable, feature card(s).
Verify correct operation.

Problem corrected?

Y N

094

Exchange 01A/A1H2 card.
Verify correct operation.

095

End of call.

096

Verify dual case/mono case switch is in Aa position.

Are both upper and lower case characters displayed?

Y N

1 1
7 7
A A
H J

A
H
6

A
J
6

MAP 02

Display MAP

PAGE 17 OF 19

097

Switch unit off.

Measure resistance from 01A/A1E2J13 to J08 (D) or 01A/A1F2G13 (M) to J8.

Is resistance less than 5 ohms?

Y N

098

Use Figure 4-13 to isolate open in switch or cable to 01A/A1H2G13.

Repair or exchange.

Reconnect coax signal cable, feature card(s).

Verify correct operation.

099

Exchange 01A/A1G2 card.

Reconnect coax signal cable, feature card(s).

Verify correct operation.

Problem still present?

Y N

100

End of Call.

101

Exchange 01A/A1E2 (D), or 01A/A1F2 (M).

Verify correct operation.

102

Are the characters displayed in the correct sequence? (See Figure 3-1, 3-2, 3-3)

Y N

1
8
A
K

1
8
A
L

A
E
1
5
|
A
K
1
7
|
A
L
1
7
|

MAP 02

Display MAP

PAGE 18 OF 19

103

Remove feature cards if present.

Is the problem still present?

Y N

104

If only one feature card is installed, exchange with another card and test for correct operation. If more than one feature card is present, isolate to one card by exchanging one card at a time.

Reconnect coax signal cable, feature card(s).

Verify correct operation.

105

Exchange 01A/A1F2, 01A/A1G2, 01A/A1E2 (D), or 01A/A1F2, G2 (M).

Reconnect coax signal cable, feature card(s).

Verify correct operation.

106

Exchange 01A/A1F2, 01A/A1E2 card (D), or 01A/A1F2, G2 (M).

Reconnect coax signal cable, feature card(s).

Verify correct operation.

107

Is keyboard exercise of test mode 2 correct?

Y N

108

Go To Map 03, Entry Point A.

1
9
A
M

A
M
1
8

MAP 02

Display MAP

PAGE 19 OF 19

109

(Display is not recognized to be ON LINE to the controller).

Verify that the controller is operational.

Is the controller communicating with other terminals?

Y N

110

Use controller Maintenance Information Manual to locate cause of problem.

111

Put test/normal switch in normal position.

Exchange 01A/A1G2, 01A/A1F2, 01A/A1E2 (D), or 01A/A1G2, F2 cards (M).

Reconnect coax signal cable, feature card(s).

Is problem still present?

Y N

112

Verify correct operation.

113

Go To Map 05, Entry Point A.

MAP 03

Keyboard MAP

PAGE 1 OF 4

ENTRY POINTS

FROM	ENTER THIS MAP		
MAP NUMBER	ENTRY POINT	PAGE NUMBER	STEP NUMBER
01	A	1	001
05	A	1	001

001

(Entry Point A)

Is this a mechanical failure? (Key binds, broken, worn or clicker sound failing)

Y N

002

Use Test Mode 2 to verify failing key or keys.

Is there more than one key failing?

Y N

003

Does any character enter from the failing key?

Y N

004

Does the cursor move, advance, in test mode when the key is pressed?

Y N

005

Exchange the module for the failing key. (See Keyboard section 6.7).

Verify repair by using Test Mode 2.

3 2 2 2
A B C D

B C D
| | |

MAP 03

Keyboard MAP

PAGE 2 OF 4

006

Verify seating of keyboard cable connector to the terminal.

Verify internal keyboard cable connector to logic gate (See Figure 4-16).

If problem is not corrected by reseating of cable connectors, exchange the keyboard logic card.

Verify the keyboard I.D. jumpers to be sure that the new logic card is the same.

(If exchange of the keyboard logic card does not correct the problem, use the keyboard cable chart to trace cable wires, connector pins to isolate a failing cable or connector.)

Verify using Test Mode.

007

Verify seating of keyboard cable connector to the terminal.

Verify internal keyboard cable connector to logic gate. (See Figure 4-16)

If problem is not corrected by reseating of cable connectors, exchange the keyboard logic card.

Verify the keyboard I.D. jumpers to be sure that the new logic card is the same.

(If exchange of the keyboard logic card does not correct the problem, use the keyboard cable chart to trace cable wires, connector pins to isolate a failing cable or connector.)

Verify using Test Mode.

008

Verify seating of keyboard cable connector to the terminal.

Is problem still present?

Y N
| |

3 3
E F

A E F
1 2 2

MAP 03

Keyboard MAP

PAGE 3 OF 4

009

Verify correct operation.

010

Exchange 01A/A1G2 then E2 card (D), or 01A/A1G2 then F2 (M).

Is problem still present?

Y N

011

Verify correct operation.

012

Verify internal keyboard cable connector to logic gate. (See Figure 4-16)

If problem is not corrected by reseating of cable connectors, exchange the keyboard logic card.

Insert the keyboard I.D. jumpers ensuring that the new logic card is jumpered the same as the card exchanged.

(If exchange of the keyboard logic card does not correct the problem, use the keyboard cable chart to trace cable wires, connector pins to isolate a failing cable or connector.)

Verify using Test Mode.

013

Is this a clicker failure?

Y N

014

Exchange the failing part by using the Keyboard repair section.

4
G

MAP 03

Keyboard MAP

PAGE 4 OF 4

015

Put the Test/Normal switch in Test position.
Clicker should sound for each key depression.

Does the clicker sound?

Y N

016

Exchange logic card 01A/A1G2 (D), or
01A/A1F2 (M).

Is trouble still present?

Y N

017

End of call.

018

Exchange the clicker. (See keyboard Repair
Section for exchange. See Chapter 6-7).

Verify correct operation.

Does clicker sound?

Y N

019

Exchange the keyboard logic card.

020

End of call.

021

Clicker has been disabled by the system.

MAP 04

Feature Error MAP

PAGE 1 OF 11

ENTRY POINTS

FROM	ENTER THIS MAP		
MAP NUMBER	ENTRY POINT	PAGE NUMBER	STEP NUMBER
01	A	1	001

001

(Entry Point A)

Does this terminal contain one or more feature cards?

Y N

002

Exchange 01A/A1G2 (D), or 01A/A1G2, F2 (M).
Reconnect coax signal cable.
Verify correct operation.

003

Is this a failure of only one feature? (Use N path if don't know)

Y N

004

Remove all feature cards but one.
Is the problem still present?

Y N

3 3 2
A B C

C
1

MAP 04

Feature Error MAP

PAGE 2 OF 11

005

(Entry Point E)

Reinstall each of the previously removed feature cards one at a time until the problem occurs again.

Did the selector pen feature card cause the problem?

Y N

006

Did the MSR feature card cause the problem?

Y N

007

Did the ECS/TEXT feature card cause the problem?

Y N

008

Did the security key lock cause the problem?

Y N

009

Did the audible alarm cause the problem?

Y N

010

Trouble has disappeared or is intermittent.

Reconnect the coax signal cable and test for proper operation.

011

Go to Page 11, Step 054, Entry Point G.

3 3 3 3
D E F G

A B D E F G MAP 04
1 1 2 2 2 2
Feature Error MAP
 PAGE 3 OF 11

012
 Go to Page 11, Step 054,
 Entry Point H.

013
 Go to Page 4, Step 023, Entry Point D.

014
 Go to Page 6, Step 031, Entry Point C.

015
 Go to Page 10, Step 046, Entry Point B.

016
 Remove the one feature card from the unit.
Is the problem still present?
 Y N

017
 Go to Page 2, Step 005, Entry Point E.

018
 Exchange card 01A/A1G02.
 Reinsert feature cards.
 Reconnect coax signal cable.
 Test for proper operation.

019
Is this a failure of the MSR feature?
 Y N

020
Is this a failure of the selector pen feature?
 Y N

6 6 4
H J K

K
3

MAP 04

Feature Error MAP

PAGE 4 OF 11

021

Is this a failure of the ECS/TEXT feature?

Y N

022

Start over at MAP 00.

023

(Entry Point D)

The ECS feature card contains a switch module and may contain a pluggable ROS APL/TEXT character generator. Verify the switch settings as follows when exchanging this card

1. All zeroes if no APL/TEXT module. See Fig. 4.7
2. Switch 1 on if the APL/TEXT module is plugged.

CAUTION

The ROS module can be damaged by static discharge when not plugged in a card. Persons handling this module must first make hand contact to the conductive foam in which the module is packed. hand contact must also be made to a conductive surface of the card before plugging in the module.

Is there an error code displayed for this trouble?

Y N

5 5
L M

L M
4 4

MAP 04

Feature Error MAP

PAGE 5 OF 11

024

Switch power off.
Remove the ECS feature card 01A/A1D02 (D),
or 01A/A1E2 (M).
Exchange pluggable module.
Verify switch settings.
Reinsert card.
Connect coax cable and insert other feature
cards if previously removed.
Use on line tests to verify correct operation.
(See Section 3.3.2.2).

Is trouble still present?

Y N

025

Return to customer.

026

Go to Step 027, Entry Point F.

027

(Entry Point F)

Switch power off.
Remove card 01A/A1D02 (D) or 01A/A1E2 (M).
Remove pluggable module from card. See Fig.
4-7.
Install module in new card.
Verify switch settings on card.
Install card in unit.
Connect coax signal cable and reinsert other
feature cards if previously removed.
Test for proper operation using on line test. See
3.3.2.2.

Has trouble been corrected?

Y N

6 6
N P

H J N P
3 3 5 5

MAP 04

Feature Error MAP

PAGE 6 OF 11

028

Reinstall the original card in 01A/A1D02 (D) or 01A/A1E2 (M) after reinstalling APL/TEXT ROS module in the original card.

Swap cards 01A/A1G02, 01A/A1F02.
Test for proper operation.

029

Return to customer.

030

Go to Page 10, Step 046, Entry Point B.

031

(Entry Point C)

Verify with customer that the MSR, Short jumper or extension cable if used and test card, PN. 1742659, operate correctly on another terminal. After verifying customer components.

Do any lights on the MSR come on when the power switch is switched on?

Y N

032

Switch power off.

Verify fuse at 01C/F1 (See Fig. 4.4).

Did fuse fail?

Y N

8 7 7
Q R S

R S
6 6

MAP 04

Feature Error MAP

PAGE 7 OF 11

033

Switch Power On.

Verify voltages at the following. For (M) version check at 01A/A1C4, C5 positions.

01A/B4B06- minus 5 VDC.

01A/B4B11-plus 8.5 VDC.

01A/B4D03-plus 5 VDC.

01A/B5D03-plus 5 VDC.

01A/B5B11-plus 8.5 VDC.

If all voltages are correct ($\pm 10\%$).

Use Fig 4-15 to trace voltage from logic card to MSR connector.

034

Exchange fuse.

Switch Unit On.

Are any lights on the MSR on?

Y N

035

Switch unit off.

Verify fuse at 01C/F1.

Did fuse fail again?

Y N

036

Verify voltages at the following points. For (M) version check at 01A/A1C4, C5 positions.

01A/B4B06- minus 5 VDC.

01A/B4B11-plus 8.5 VDC.

01A/B4D03-plus 5 VDC.

01A/B5D03-plus 5 VDC.

01A/B5B11-plus 8.5 VDC.

If all voltages correct ($\pm 10\%$).

Use Fig 4-15 to trace voltage from logic card to MSR connector.

8 8
T U

Q T U
6 7 7

MAP 04

Feature Error MAP

PAGE 8 OF 11

037

Use Fig 4-15 to trace voltage from logic card to MSR connector.

038

Check for proper operation.

039

Place the test/normal switch in TEST position. Read in the test card.

Did the yellow light on the MSR come on?

Y N

040

Exchange logic card 01A/A1B4; read in test card again. If yellow light does not light, verify cables from logic gate to MSR connector. (See Figure 4-15.)

041

Put the Test/Normal switch in normal position. Verify correct operation by performing test as described in section 3.3.2.2. starting at Step 9 Routine 3.

Was test successful?

Y N

042

Exchange logic card 01A/A1B04.

Verify correct operation by performing tests as described in section 3.3.2.2 starting at step 9 Routine 3.

Was test successful?

Y N

9 9 9
V W X

V
8

W
8

X
8

MAP 04

Feature Error MAP

PAGE 9 OF 11

043

Exchange logic card 01A/A1G02, perform test for MSR as described in 3.3.2.2. If trouble persists verify cable from logic gate to MSR connector (See Fig 4-15).

044

Return to customer.

045

Return to customer.

MAP 04

Feature Error MAP

PAGE 10 OF 11

046

(Entry Point B)

Verify that the selector pen lens is clean. If lens is dirty or damaged, exchange or clean using isopropyl alcohol, as required. See Chapter 6.8 for removal and exchange.

Does the selector pen still fail?

Y N

047

Check selector pen using on-line tests as described in 3.3.2.1.

048

Verify +44 volts at 01A/A1C2U09, 01A/A1E2U09 (D), or use 01A/A1G2U09 (M).

Verify -12 volts at 01A/A1C2S08, 01A/A1E2S08 (D), or use 01A/A1G2S08 (M).

Are voltages correct?

Y N

049

Exchange card 01A/A1H02.

Reconnect coax signal cable.

Reinsert feature cards if removed.

Verify for correct operation.

050

Exchange the selector pen feature card at 01A/A1C04 or 01A/A1E04 (D) or for 01A/A1G4 (M).

Reconnect coax signal cable.

Reinsert feature cards if removed.

Verify for correct operation.

Has the problem been corrected?

Y N

Y N

Y Z

Y Z
1 1
0 0

MAP 04

Feature Error MAP

PAGE 11 OF 11

051

Exchange the selector pen.
Verify for correct operation.

Is the problem still present?

Y N

052

End of call.

053

Exchange 01A/A1G02, E02, F02 (D) or
01A/A1F2, G2 (M).

Verify for correct operation.

054

(Entry Point G)

Use Diagram at Figure 4-13 and 4-14 to isolate problem.

01A/A1H2J5 connects to 01A/A1G2J5 (D) or 01A/A1F2J5 (M). Alarm should sound when G2J5 (D) or F2J5 (M) is grounded (+-2 sec). Verify audible alarm control setting if alarm does not sound.

Exchange 01A/A1G2 (D) or 01A/A1F2 (M) card or audible alarm assembly 01C/DS1 to correct problem.

(Entry Point H)

Use diagram at 4-14 to isolate problem. 01A/A1H2G3 is ground when the security key is off (removed). 01A/A1H2J4 is ground when the security key feature is present.

End of call.

MAP 05

System Indicated Failure MAP

PAGE 1 OF 6

ENTRY POINTS

FROM	ENTER THIS MAP		
MAP NUMBER	ENTRY POINT	PAGE NUMBER	STEP NUMBER
01	A	1	001
01	B	2	007

EXIT POINTS

EXIT THIS MAP		TO	
PAGE NUMBER	STEP NUMBER	MAP NUMBER	ENTRY POINT
6	035	03	A
4	020	04	A
6	033	04	A

001

(Entry Point A)

Does the indicator row, on the screen, display an error code?

Y N

002

Are there any characters or symbols displayed in the indicator row?

Y N

003

Is the Test/Normal switch in the Normal position?

Y N

004

Put switch in Normal position.
Verify correct operation.

6 5 2
A B C

C
1

MAP 05

System Indicated Failure

PAGE 2 OF 6

005

Is the security key ON (full clockwise)? (Use the Y path if there is no security key feature).

Y N

006

Switch ON and verify correct operation.

007

(Entry Point B)

Use the error log to determine if this terminal has had errors that cause the control unit to disable this terminal.

Has this terminal been logged off by the control unit? (See error log codes, 3.3.2.3, for log off codes.)

Y N

008

NO or Don't Know.

Switch unit off then on.

Does the subsystem ready indicator come on in the indicator row?

Y N

009

Exchange 01A/A1G2 card.

Is problem still present?

Y N

010

Verify correct operation.

5 5 3
D E F

F
2

MAP 05

System Indicated Failure

PAGE 3 OF 6

011

(The following is a test of the coax cable from the terminal to the controller. The presence of controller signals will not affect test). Disconnect the coax cable from the terminal. Measure the resistance from the center pin of the connector on the cable to the outer case of the connector. Use Rx10 range.

Is resistance between 1.8K and 2.6K ohms?

Y N

012

Resistance higher than 2.6K indicates an open cable, bad cable connector or defect at the controller. (Coax resistance is 30 ohm/1000 feet).

Repair or exchange.

013

(The following is a test from the coax connector on the terminal to card 01A/A1G2).

Test the resistance from the center contact of the connector on the terminal to the outer case of the connector. Do not use the frame of the terminal. Use Rx1 range.

Does resistance measure between 0 and 3 ohms?

Y N

014

If resistance is too high, test the coax connector on the card gate, cable for breaks and reseat the 01A/A1G2 card. Remove 01A/A1G2 card. Meter should indicate an open condition. If not exchange coax cable from terminal connector to logic gate.

4
G

G
3

MAP 05

System Indicated Failure

PAGE 4 OF 6

015

Exchange 01A/A1F2 and 01A/A1E2 (D) or 01A/A1F2 (M).

Is problem still present?

Y N

016

Verify correct operation.

017

(Entry Point D)

Was the terminal logged off because of errors?
(See error log codes, 3.3.2.3, for log off codes)

Y N

018

Does this Terminal contain feature cards?

Y N

019

Exchange card 01A/A1G2.
Verify correct operation

020

Go To Map 04, Entry Point A.

021

(Entry Point C)

Error code 77 for 3276 or 04 for 3274?

Y N

022

Errors because of Feature error? (See 3.3.2.3 for codes)

Y N

5 5 5
H J K

B D E H J K MAP 05
1 2 2 4 4 4

System Indicated Failure

PAGE 5 OF 6

023

Verify coax connectors, cable and seating of 01A/A1G2 card.
If errors remain, exchange 01A/A1G2 card.

024

If the feature causing error is identified exchange that card.
If the feature is not identified or this terminal does not have features, exchange 01A/A1G2 card.

Is the problem still present?

Y N

025

End of call.

026

Exchange 01A/A1F2, E2 (D) or 01A/A1F2 (M).
Verify correct operation.

027

Exchange 01A/A1F2, G2 cards.
Verify correct operation.

028

Exchange 01A/A1G2, F2, E2 (D) or 01A/A1G2, F2 (M).
Verify correct operation.

029

Go to Page 4, Step 021, Entry Point C.

030

Go to Page 2, Step 007, Entry Point B.

MAP 05

System Indicated Failure

PAGE 6 OF 6

A
↓

031

Is Error Code other than 41, 42, 210 or 212?

Y N

032

Remove feature cards if present.

Is problem still present?

Y N

033

Go To Map 04, Entry Point A.

034

Disconnect Keyboard cable from Terminal.

Is problem still present?

Y N

035

Go To Map 03, Entry Point A.

036

Exchange 01A/A1G2.

Connect Keyboard cable to Terminal.

Exchange feature cards.

Verify correct operation.

037

Go to Page 4, Step 017, Entry Point D.

Chapter 3. Maintenance Aids

3.1 Introduction

Maintenance aids for the 3278 display station include switches, indicators, and diagnostic tests.

3.2 Switches and Indicators

The 3278 switches and indicators are described in Figures 4-1 and 4-2 in Chapter 4.

3.3 Operation Tests

Operation tests are used to sense failures both for problem determination and for repair verification. Both offline and online tests are available.

3.3.1 Offline Tests

The 3278 offline tests are in 3278 logic. The test logic is activated by setting the Normal/Test switch to the Test position, taking the 3278 offline to its control unit, and putting it in test mode. There are three test modes: Test Mode 1, Test Mode 2, and Test Mode 3.

3.3.1.1 Test Mode 1

DISPLAY STATION TEST		
<ul style="list-style-type: none"> ● Tests 3278 Display Station offline from the control unit. ● Does <i>not</i> test coax driver/receiver and display features; they may be tested with online test 0 (refer to 3.3.2.2). 		
<i>Test Name</i>	<i>Activity</i>	<i>Result</i>
Test Mode 1: Pattern Display	<p>Displays a predetermined pattern of characters.</p> <p>Mode Entry: Set Aa/A to Aa. Set Normal/Test to Test.</p>	<p>Fills display with pattern of characters shown in Figure 3-1, 3-2, or 3-3. Compare the test pattern lines shown in the inset with the corresponding lines on the screen. Verify that the characters are in correct sequence.</p> <p>This is a test of the <i>character generator, storage, and control logic</i>. Character-generator failure causes wrong or defective characters to be displayed at any point or points on the screen, and control failure affects all characters.</p>

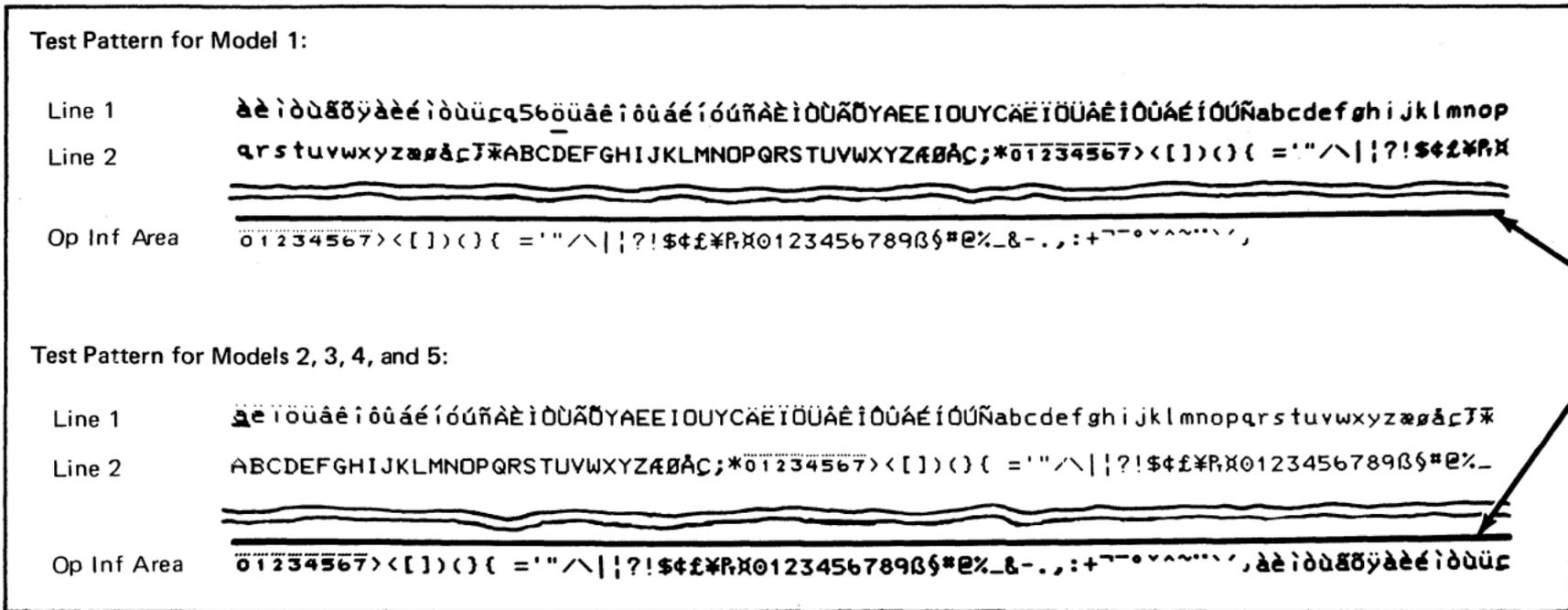

(Divider Line)

Figure 3-1. Test Patterns

3.3.1.2 Test Mode 2

**Test Mode 2:
Key-to-CRT
Test** (used to test the keyboard scan codes)

Provides a path from keyboard to display.

Mode Entry: Automatic, after display is loaded with Mode 1 pattern of characters.

Key in any characters (but do not press Control key).

Characters keyed in replace characters displayed in Test Mode 1, beginning at top left of display. This is a test of keyboard scan codes.

Note: *Regardless of the characters that appear on the key-tops, the characters displayed are those shown in the inset below. Notice that certain keys cause double-character entry, the first when the key is pressed and the second when it is released: these keys are labeled nn, mm, oo, and pp in the inset*

Keyboard

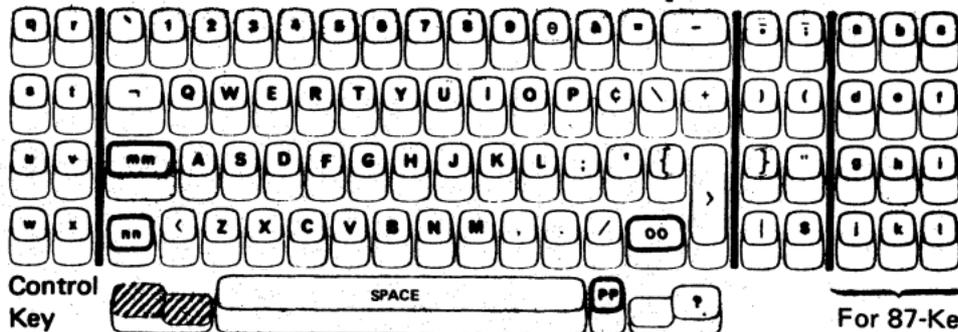

For 87-Key
Keyboards

(Katakana)

Test Mode 2:
Key-to-CRT
Test (used to
test the key-
board scan
codes)

Provides a path from keyboard to display.

Mode Entry: Automatic, after display is loaded
with Mode 1 pattern of characters.

Key in any characters (but do not press
Control key).

Characters keyed in replace characters displayed in Test
Mode 1, beginning at top left of display. This is a test of
keyboard scan codes.

Note: *Regardless of the characters that appear on the key-
tops, the characters displayed are those shown in the inset
below. Notice that certain keys cause double-character
entry, the first when the key is pressed and the second
when it is released: these keys are labeled NN, MM, OO,
YY, and PP in the inset.*

Keyboard

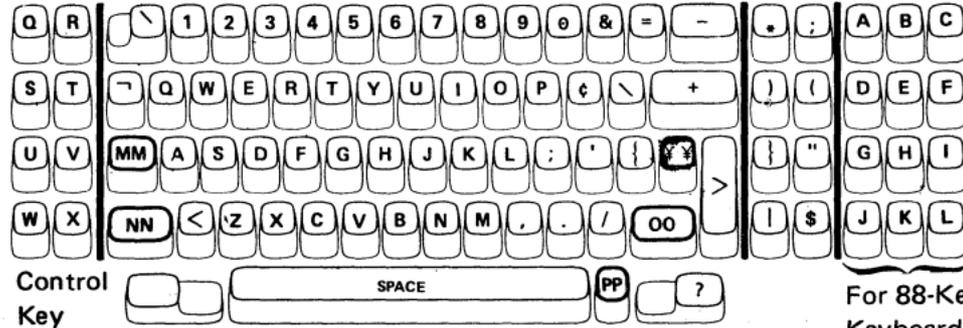

For 88-Key
Keyboards

Japanese (English)

Test Mode 2:
Key-to-CRT
 Test (used to test the keyboard scan codes)

Provides a path from keyboard to display.

Mode Entry: Automatic, after display is loaded with Mode 1 pattern of characters.

Key in any characters (but do not press Control key).

Characters keyed in replace characters displayed in Test Mode 1, beginning at top left of display. This is a test of keyboard scan codes.

Note: Regardless of the characters that appear on the key-tops, the characters displayed are those shown in the inset below. Notice that certain keys cause double-character entry, the first when the key is pressed and the second when it is released: these keys are labeled **nn**, **mm**, **oo**, **¥¥**, and **pp** in the inset.

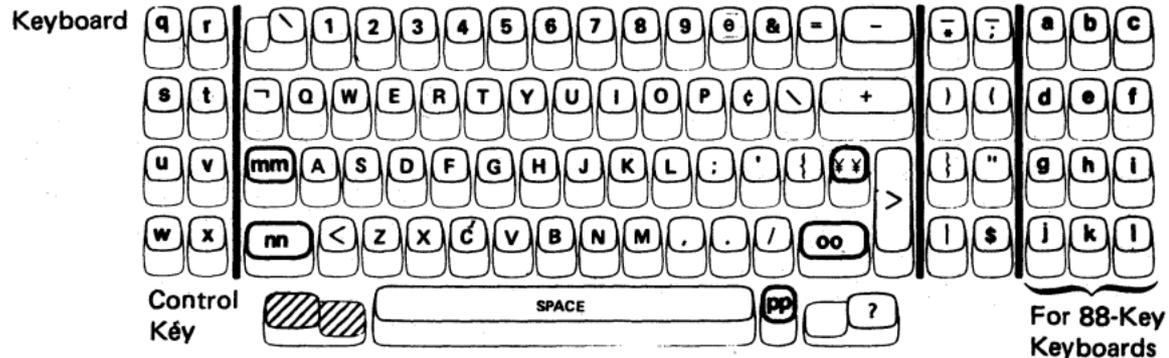

3.3.1.3 Test Mode 3

Test Name	Activity	Result
Test Mode 3: Test Logic Area	<p>Provides two paths from keyboard to logic: logic-area test path and data path.</p> <p>Mode Entry: Press Control key.</p> <p>Logic Area Test Entry: See the following page for suggested sequence of logic area tests.</p> <p>Suggested Logic Area Test Sequence</p> <p>1 Press C key. —————→</p> <p>Press Control key.</p> <p>2 Press B key —————→</p> <p>Press B three more times (to clear status). —————→</p> <p>Press Control key.</p>	<p>Note: All references to keys to be used in Test Mode 3 are identified by the inset shown for Test Mode 2. (Do not identify keyboard keys by the characters that appear on the keytops.)</p> <p>Characters keyed in during Test Mode 2 are replaced by Test Mode 1 pattern; initial power-on status is loaded into status register.</p> <p>2 appears in first position of operator information area. (Correct response for power-on status.) (A tone sounds if the audible alarm feature is installed, on (D) type only.)</p> <p>First position of operator information area becomes 0.</p>

Test Name	Activity	Result				
Test Mode 3 (Cont'd) 3	Press J key. Press Control key.	A character — dependent upon the display model and keyboard type (see inset below) — appears in the first position of the operator information area.				
<i>Keyboard Types</i>		<i>Character</i>				
		<i>Models 1</i>	<i>2</i>	<i>3</i>	<i>4</i>	<i>5</i>
Typewriter Keyboard without Numeric Lock		Š	Ć	Ś	⌘	I
Typewriter Keyboard without Numeric Lock [Katakana or Japanese (English)]		Ü	Ñ	Á	ø	è
Typewriter Keyboard with Numeric Lock		C	E	G	O	M
Data Entry with Numeric Lock		s	u	w		ã
Data Entry without Numeric Lock		A	B	▶	?	B
Data Entry Keypunch with Numeric Lock		c	e	g	o	m
Data Entry Keypunch without Numeric Lock		š	ć	ś	i	i
APL		ï	ü	ê	ú	í
APL with Numeric Lock		/	/		P _t	£
APL (Katakana)		テ	ナ	マ	マ	へ
TEXT Keyboard		ì	Ù	Ö	Y	O
TEXT Keyboard with Numeric Lock		2	4	6	%	#

4

Press B key twice. Press Control key.

Clears status.

5

Press N key.
Press Control key.

A character — dependent upon security key and monospace switches (see inset below) — appears in first position of operator information area.

*Security Keylock**Monospace Switch:*

A, a

A

No Security Keylock

0

A

Security Keylock ON (full-clockwise position)

&

Q

Security Keylock OFF

1

B

Note: Displays with the Katakana Keyboard will display characters in Column A.

6

Press B key twice.
Press Control key.

Clears status.

7

Press C key.
Press Control key.

Test Mode 1 pattern remains displayed.

8

Press D key.
Repeat pressing D as desired.

First position of operator information area is loaded with the character that is at cursor position when D is pressed. Cursor then advances one character position.

<i>Test Name</i>	<i>Activity</i>	<i>Result</i>
Test Mode 3 (Cont'd)		
9	Press Control key, B key twice, then Control key.	
10	Press V key.  Press Control key.	First position of operator information area is loaded with the character that is at cursor position when V is pressed.
11	Press C key. Press Control key.	
12	Press B key twice.	
13	Press F key. 	First position of operator information area is loaded with character 0.
14	Press C key.  Press Control key, B key twice, then Control key.	Test Mode 1 pattern is displayed.

15

Press M key.
Press any keys except Control key.
Press Control key.



Characters keyed in replace characters displayed in Test Mode 1.

16

Press U key.
Press any keys except Control key.
Press Control key.



Cursor moves with each key depression, but stays within a 256-character position area.
If cursor is within unchanged Test Mode 1 pattern, it will move under same character as on key that is pressed (except for uppercase characters displayed in the top row).

17

Press E key.
Press any keys except Control key.
Press Control key.



Cursor moves many positions with each key depression — off screen, with most keys.

18

Press C key.
Press Control key.
Press B key twice, then Control key.

19

Press G key twice.
Press Control key, B key twice, then Control key.



....
Display changes to all 0s, except for operator information area; cursor (which can be made visible by next step) moves to first position of operator information area.

Test Name	Activity	Result																					
Test Mode 3 (Cont'd)	<p data-bbox="416 288 1030 319">Press K key; then press " key. </p> <p data-bbox="416 329 1030 360">Press Control key.</p> <p data-bbox="416 365 1030 396">Press C key, then Control key. </p> <p data-bbox="416 396 1030 427">Press K key.</p> <p data-bbox="416 433 1030 490">Press one of the following keys (see inset below) according to the function desired:</p> <table border="1" data-bbox="416 500 987 785"> <thead> <tr> <th colspan="3" data-bbox="416 500 987 598">(Model 5 132-character length only)</th> </tr> </thead> <tbody> <tr> <td data-bbox="416 598 733 629">Reverse and blink cursor.</td> <td data-bbox="733 598 808 629">"</td> <td data-bbox="808 598 987 629">T</td> </tr> <tr> <td data-bbox="416 629 733 660">Reverse cursor.</td> <td data-bbox="733 629 808 660">'</td> <td data-bbox="808 629 987 660">S</td> </tr> <tr> <td data-bbox="416 660 733 692">Blink cursor.</td> <td data-bbox="733 660 808 692">=</td> <td data-bbox="808 660 987 692">R</td> </tr> <tr> <td data-bbox="416 692 733 723">Normal cursor.</td> <td data-bbox="733 692 894 723">Space key</td> <td data-bbox="808 692 987 723">Q</td> </tr> <tr> <td data-bbox="416 723 733 754">Inhibit cursor.</td> <td data-bbox="733 723 808 754">/</td> <td data-bbox="808 723 987 754">U</td> </tr> <tr> <td data-bbox="416 754 733 785">Inhibit display.</td> <td data-bbox="733 754 808 785">?</td> <td data-bbox="808 754 987 785">Y</td> </tr> </tbody> </table> <p data-bbox="416 806 1030 837">Press Control key, then C key, then Control key.</p> <p data-bbox="416 842 1030 873">Press B key twice, then Control key</p>	(Model 5 132-character length only)			Reverse and blink cursor.	"	T	Reverse cursor.	'	S	Blink cursor.	=	R	Normal cursor.	Space key	Q	Inhibit cursor.	/	U	Inhibit display.	?	Y	<p data-bbox="1073 308 1929 339">Reverse cursor appears.</p> <p data-bbox="1073 365 1929 396">Test pattern reappears.</p>
(Model 5 132-character length only)																							
Reverse and blink cursor.	"	T																					
Reverse cursor.	'	S																					
Blink cursor.	=	R																					
Normal cursor.	Space key	Q																					
Inhibit cursor.	/	U																					
Inhibit display.	?	Y																					
20																							
21																							
22																							

- 23 Press W key.
- 24 Press * key.
Press Control key.
- 25 Press G key.
- 26 Press A key. —————▶ All positions from top left of screen to first "a" become 0.
Press Control key.
- Press B key. —————▶ Loads first position of operator information area with 3.
Press B key again, then Control key.
- 27 Press O (alpha) key. —————▶ (Prepares for testing display intensity control.)
- 28 Press I (alpha) key. —————▶ All characters on screen display with *high intensity*,
Press Control key, then B key twice. except operator information area.
Press Control key. Cursor advances to first (*) in row 2.
- 29 Press O (alpha) key.
- 30 Press Q key. —————▶ All characters from cursor's previous position to end of
screen and characters on the first line to the first lowercase
"a" display with *normal intensity*. Cursor also advances
to row 3.

Test Name	Activity	Result
Test Mode 3 (Cont'd)		
31	Switch power off, then on. —————→ Press Control key, B key twice, then Control key.	Power-On Reset occurs.
32	Press G key twice. —————→ Press Control key, then B key twice. Press Control key.	All positions become 0 except operator information area. ****
33	Press G key twice. —————→ Press Control key. Press B key twice.	Operator information area displays 0s. ****
34	Press M key.	
35	Press and hold 2 key until 2's appear in top line ((D) type). Press and hold 3 key until 3's appear in top line ((M) type).	
36	Press and hold 4 key to enter eight to ten 4's ((D) type).	

37 Press and hold 5 key to enter eight to ten 5's
((M) type).

Press and hold 8 key to enter eight to ten 8's
((D) type).

Press and hold 9 key to enter eight to ten 9's
((M) type).

38 Press Control key: press B key twice,
then Control key.

39 Press W key

40 Press \bar{x} key.

Press Control key.

Press B key twice, then Control key.

41 Press S key.

42 Press 2 key. → Cursor moves back to last 2 entered ((D) type).

Press 3 key. → Cursor moves back to last 3 entered ((M) type).

Press Control key.

43 Press B key twice, then Control key.

44 Press Q key.

<i>Test Name</i>	<i>Activity</i>	<i>Result</i>
45 *****	Press 8 key. _____ Press 9 key. _____ This concludes tests that can be performed by the Offline Test (Test Mode). Display station features must be tested online; see Online Test 0 (par. 3.3.2.2).	Cursor moves forward to first 8 entered ((D) type). Cursor moves forward to first 9 entered ((M) type).

3.3.2 Online Tests

The 3278 online tests are in the control unit to which the 3278 is attached. When the 3278 is attached to a 3274 or 3276, online tests may be requested from any online display station with a keyboard, and may be run on any online terminal attached to the same control unit. Results, if any, of the test are displayed at the requesting display station. Seven online tests can be selected:

When the 3278 is attached to a control unit/adaptor other than a 3274 or 3276, refer to the documentation for the control unit/adaptor for the differences to the online tests.

- Test 0 — Display Operation
- Test 1 — Error Log Display
- Test 2
- Test 3
- Test 4 — Error Log Erase (for 3274, erases error log for selected device;
for 3276, erases entire error log)

Test 5

Test 6

(Refer to the control unit documentation for a description of tests 2, 3, 5, and 6.)

<ul style="list-style-type: none"> Run test other than 0 on terminal other than requesting display. 	Key in: AA/B Press: Enter	Selected test begins.
3. Re-enter if X symbol is	<input type="checkbox"/> You tried to select an in-session terminal for test 0 <input type="checkbox"/> You used an invalid test number or address. <input type="checkbox"/> You used more than one slash (/) and/or had space(s) in your format. <input type="checkbox"/> You did not begin test format at position 0 (upper-left position of display). Press Reset; re-enter test format.	Do Not Enter \times , Op Check $\frac{f}{t}$, and Function Not Available -f are displayed in operator information area. Do Not Enter \times , Op Check $\frac{f}{t}$, and Wrong Number # ? are displayed in operator information area. Only TEST is displayed.
4. Interpret test results.	Invoking message is retained and is suffixed with +, -, or 0, where: + = succeeded - = failed 0 = device power off and these may be prefixed by a routine number.	Example: AA/ 2- ↑ ↑ ↑ TA Address Test 0 Routine 2 Failed <i>Note:</i> Applicable only to Test 0.
5. Continue test.	Press and hold ALT, and strike CLEAR.	Enter another test (step 2).
6. End test.	Press and hold ALT; strike TEST and then release ALT.	TEST is erased from display.

3.3.2.2 Test 0, Display Operation

<i>Test or Routine Name</i>	<i>Activity</i>	<i>Result</i>
Test 0: Display Function.	To determine that terminal is functioning overall.	
Routine 1: TA Test (3276 only)	Check basic TA functions—register, serdes, command decoder, etc., operations; driver/receiver operation excluded.	Stop on error. Display test result on requesting display. If no error, go to next routine.
Routine 2: Link Test (3276 only)	Check link by issuing Reset and receiving a POR response.	Stop on error. Display test result on requesting display. If no error and if a display is being tested, go to next routine; otherwise stop.
Routine 3: Interactive Test (Display only; not for printer)	Permit operator testing of selector pen and keyboard functions. Display test pattern. Sound audible alarm (if feature is installed).	Test pattern is displayed; it and test procedure are described in inset below.

Test Pattern Definition

- Line 1: CCCC identifies the control unit (3274 or 3276) to which the 3278 is attached.
 NN is the port number (00 through 31).
- Line 2: ?SEL PEN and SEL PEN are high-intensity, protected, and selector-pen-detectable fields.
- Line 3: &SEL PEN and > SEL PEN are normal-intensity, protected, and selector-pen-detectable fields.
- Line 4: Non-display field with NON preceding normal-intensity and protected field DISPLAY INSERT. If blanking circuits on analog card fail, NON can be seen.
 CK (and two null characters) is normal-intensity, unprotected, and non-detectable field, followed by another normal-intensity, unprotected, and non-detectable field containing cursor.

(Line 1)
 (Line 2)
 (Line 3)
 (Line 4)

Test Pattern

```

TEST:      CCCC  NN
?SEL      PEN           SEL PEN
           &SEL PEN       > SEL PEN
DISPLAY    INSERT CK  -
  
```

(Routine 3: Interactive Test, Test Procedure)

Test Procedure

- | | | |
|--|---|--|
| 1. Move cursor under C of CK. | | |
| 2. Press \hat{a} key. | → | ^ (displays in operator info area) |
| 3. Press A. | → | DISPLAY INSERT ACK (displays in fourth line) |
| 4. Press B. | → | DISPLAY INSERT ABCK (displays in fourth line) |
| 5. Press C. | → | DISPLAY INSERT ABCK (no change in fourth line) |
| | → | ✘ ⤴ ⤵ ^ (displays in operator info area) |
| 6. Press Reset. | → | ✘ ⤴ ⤵ ^ is erased. |
| 7. If no selector light-pen, ECS, or MSR features, press and hold ALT, strike TEST, release ALT | → | Test pattern is erased; TEST is erased. (Test is ended.) |
| 8. If selector light-pen is a feature: | | |
| a. Touch pen on ?SEL PEN | → | ⤵ SEL PEN SEL PEN (displays in second line) |
| (If ✘ appears in operator info area, reset and retry; if no change in display, increase brightness and retry.) | | |
| b. Touch pen again on same field. | → | ? SEL PEN SEL PEN (displays in second line) |
| c. Touch pen on ⤵ SEL PEN | → | & SEL PEN ? SEL PEN (displays in third line) |
| d. Touch pen again on same field. | → | & SEL PEN ⤵ SEL PEN (displays in third line) |
| e. Do step 7 to end test. | | |

9. If MSR is a feature:

- a. Move cursor to first position in fifth line (line below test pattern).
- b. Read test card
- c. Hold ALT and press TEST to end the test.

Cursor moves number of positions equal to number of characters on test card plus three spaces; green light on reader lights, and ✕-f is displayed in operator information area.

10. If ECS feature:

- a. Move cursor to sixth line.
- b. Hold ALT, and press APL ON/OFF key.
- c. Type in any or all APL characters as shown on the keytops and key faces.
- d. Hold ALT and press TEST to end test.

APL appears in indicator row
Correct character should appear for each key entered

3.3.2.3 Test 1, Error Log Display

From the last time that control unit power was turned on, all errors sensed by the control unit were recorded in the error log. When control unit power is turned off, the error log is erased. The error log for any terminal attached to the control unit can be displayed by requesting online test 1. The following error log formats are displayed at the requesting display station:

3274 Error Log

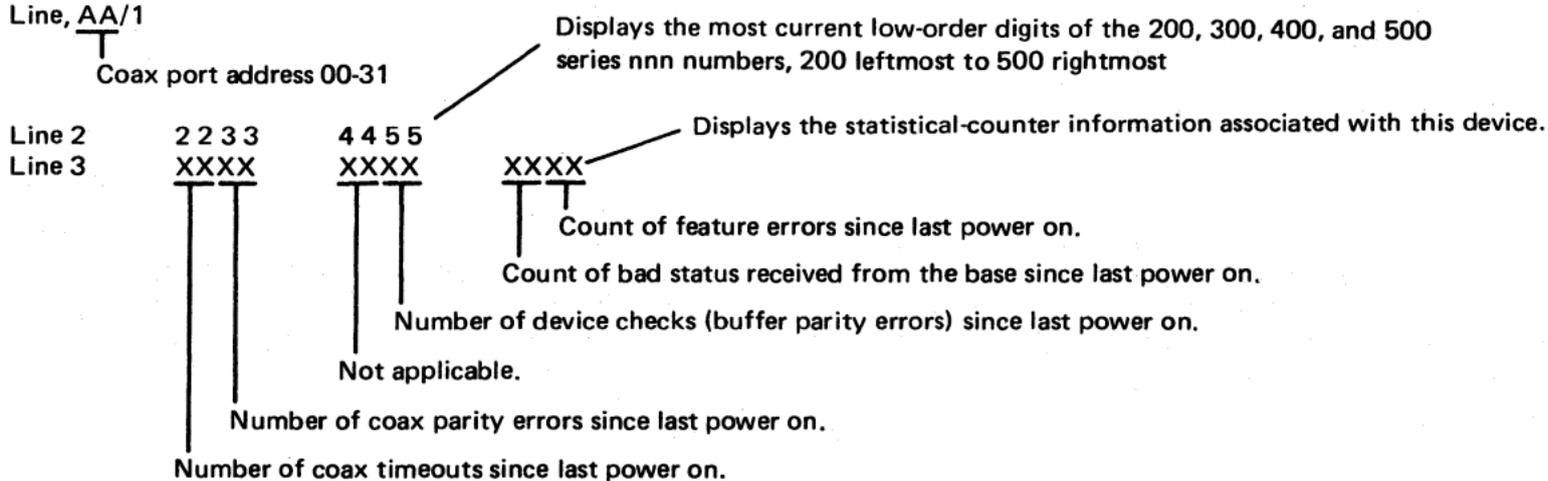

For example:

```
03/1
0400 0000
0000 0002 0000
```

The last error detected by the display was error code 204. This was a storage error (buffer parity error). Two of these errors have been detected since the display was powered on.

3274 Display Error Log Codes

These errors appear on the screen as  2xx, where xx is one of the 2-digit numbers listed below.

03	= Feature bus error	11	= Invalid Status received
04*	= Storage error	12	= Invalid Scan Code received
05	= Unsupported feature attached	22	= Invalid Selector Pen Status or Command Q failure
06	= Incorrect feature address	23	= ECS buffer parity
07*	= Lost Op Complete this display	24	= Invalid MSR Status or Command Q failure
08	= Invalid Op Complete (received unexpected Op Complete)	25	= ECS Status/Initialization error
09*	= Command Q failure	26	= ECS Command Q failure
10	= Invalid keyboard attached (no table)	27	= ECS WRT ALT/Command Q failure

*Control unit may log off device.

3276 ERROR LOG

Test 1:
Error Log Display

Display the terminal and common error logs.

Error logs are displayed at requesting display;
see inset below.

Error Log Display

	YY											
	X0	X1	X2	X3	X4	X5	X6	X7	X8	X9	XA	XB
0X	XX	---	XX	---	XX	---	---	---	---	XX		
1X	---	XX	---	---	---	---	---	XX	---	---		
2X	---	---	---	---	---	XX	---	---	XX	---		
3X	XX	---	---	XX	---	---	---	---	XX	---		
4X	---	---	03	---	---	---	---	---	---	---		
	Example: Error code 42 (keyboard overrun) has occurred three times. For error code interpretation, see par. 3.3.2.3.											
9X	---	XX	---	---	XX	---	XX	---	---	---		

where:

YY = Terminal address
 XX = Error count (in hexadecimal)
 --- = No error encountered.

Error log codes (3276 Control Unit):

41 Keyboard error (invalid code)	71 Adapter receive parity
42 Keyboard overrun	72 Data parity error*
43 MSR data parity	73 Lost Op complete*
44 SP data parity	74 Feature timeout*
60 MSR timeout	77 Device Check (terminal buffer parity)*
61 SP timeout	0A Total count of error code 70
70 Timeout (no response from the terminal)*	0B Total count of adapter Receive parity

*Control unit may log off device.

Refer to the control unit manuals for definitions of other error codes.

Example: In the error log for terminal YY, where a horizontal line through 4Z and a vertical line through Z1 meet, the value of XX is 06. This shows that, since the control unit power was turned on, terminal YY has had 6 errors of the 41 code (keyboard error) type, which were sensed by the control unit.

3.3.2.4 Error Log/Repair Action

3274 Control Unit

- 02 (may not display terminal logged off),
01A/A1F2(M)
- 03 01A/A1G2, feature card B4 or C4(D),
01A/A1F2, feature card G4 or E2(M)
- 04 01A/A1F2, 01A/A1G2
- 05 Wrong feature card, 01A/A1G2
- 06 Wrong feature card, 01A/A1G2
- 07 01A/A1G2(D), 01A/A1F2, G2(M)
- 08 01A/A1G2(D), 01A/A1F2, G2(M)
- 09 Coax port transmission failure

3276 Control Unit

- 41 Keyboard logic card, keyboard
cable, 01A/A1G2(D), 01A/A1F2(M)
- 42 Keyboard logic card, 01A/A1G2(D),
01A/A1F2(M)
- 44 01A/A1C4, 01A/A1E4, 01A/A1G2(D),
01A/A1G4, 01A/A1G2(M)
- 60 01A/A1B4, 01A/A1G2, MSR
- 61 01A/A1C4, 01A/A1E4, 01A/A1G2(D),
01A/A1B4, 01A/A1G2(M)

- 10 Keyboard ID jumpers
- 11 01A/A1G2(D), 01A/A1F2, G2(M)
- 12 01A/A1G2, keyboard logic card
- 22 01A/A1C4, E4, G2(D), 01A/A1G2, G4(M)
- 23 Feature card 01A/A1D02, G02(D), 01A/A1E2, G2(M)
- 24 01A/A1B4, G4(D), 01A/A1B4, G2(M)
- 25 Feature card 01A/A1D02, G02(D), 01A/A1E2, G2(M)
- 26 Feature card 01A/A1D02, G02(D), 01A/A1E2, G2(M)
- 27 Feature card 01A/A1D02, G02(D), 01A/A1E2, G2(M)

- 70 01A/A1G2 (check Control Unit logic), coax cable
- 71 Card A-G2, coax cable
- 72 01A/A1G2, 01A/A1F2
- 73 01A/A1G2
- 74 01A/A1G2, feature card B4, E4, or C4
- 77 01A/A1F2, 01A/A1G2

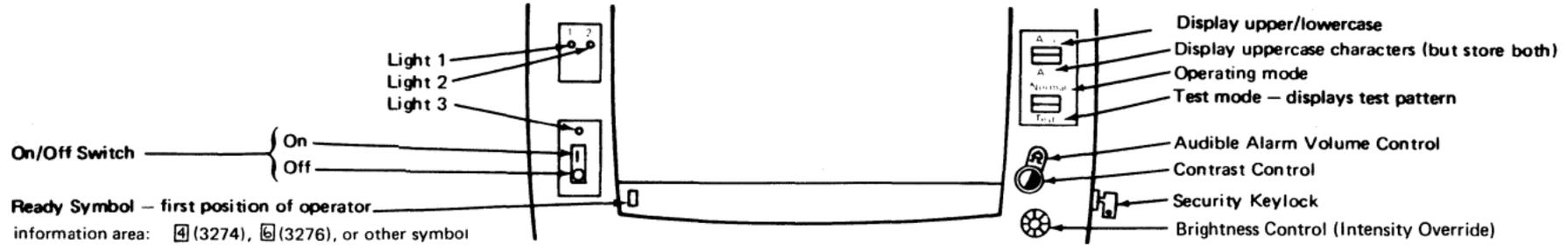

Figure 4-1. Switches and Indicators

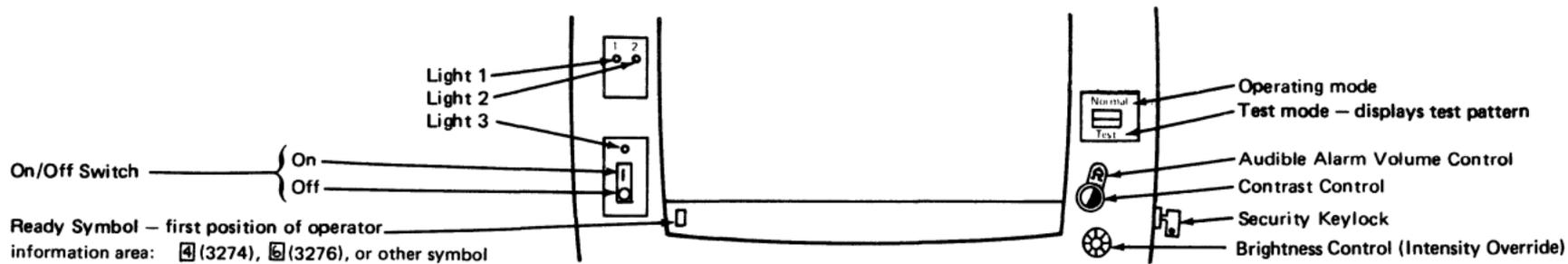

Figure 4-2. Switches and Indicators (Katakana)

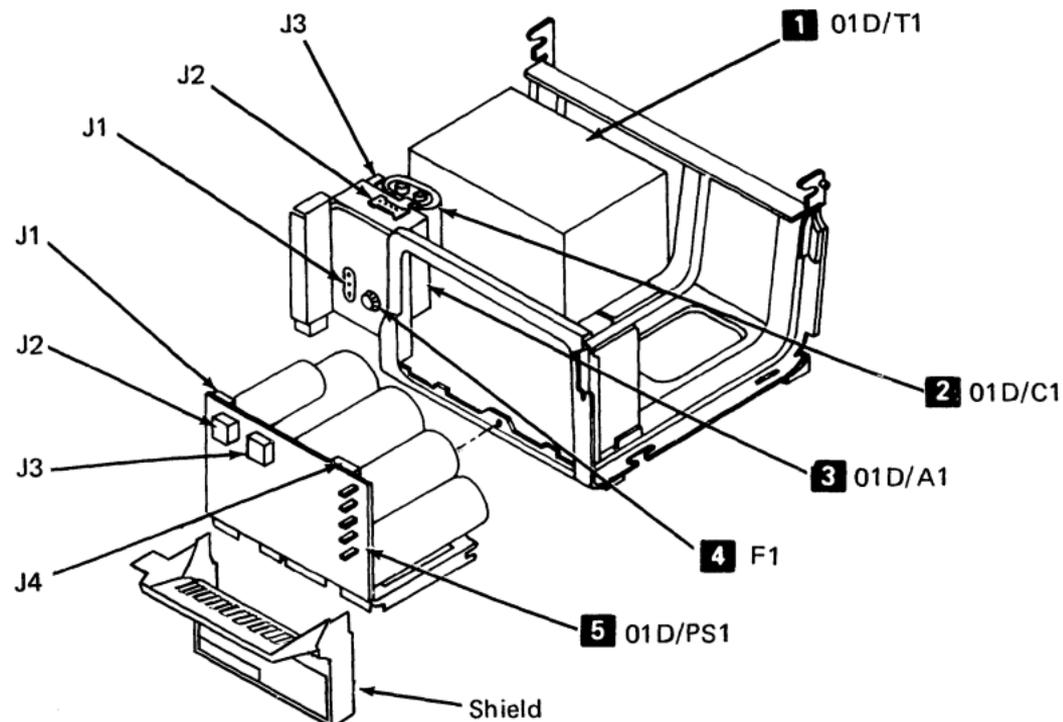

Figure 4-3. Lower Frame

Key	Description	PN
1	Ferro – US/Canada	1655366
	EMEA/AFE 60 Hz Lo	5893800
	AFE 50 Hz Lo	5893801
	AFE 50 Hz Hi	5893802
	EMEA 50 Hz Hi	4119632
2	Capacitor	6814311
3	Prime Power Asm	1743110
4	Primary Fuse (F1)	
	US/Canada	332009
	EMEA/AFE 60 Hz Lo	332009
	AFE 50 Hz Lo	332009
	AFE 50 Hz Hi	1176668
	EMEA 50 Hz Hi	1176668
5	Low-Voltage Asm	1743120

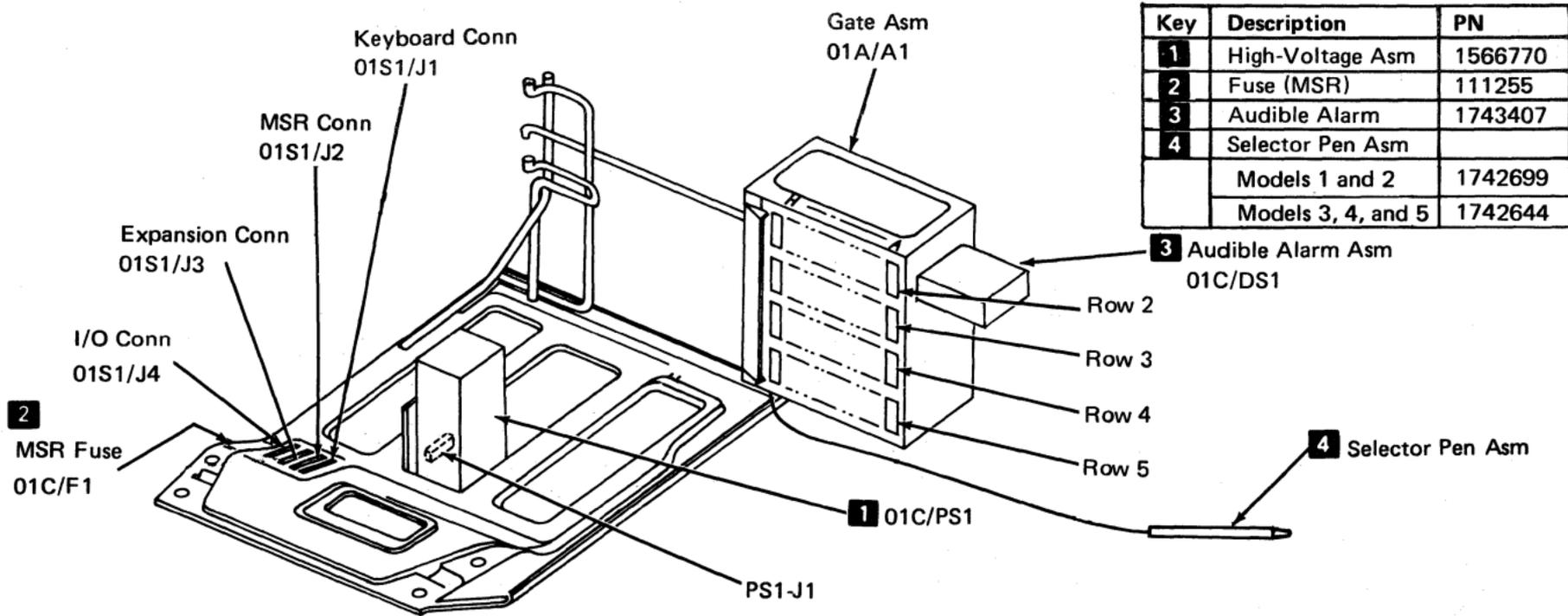

Figure 4-4. Upper Frame

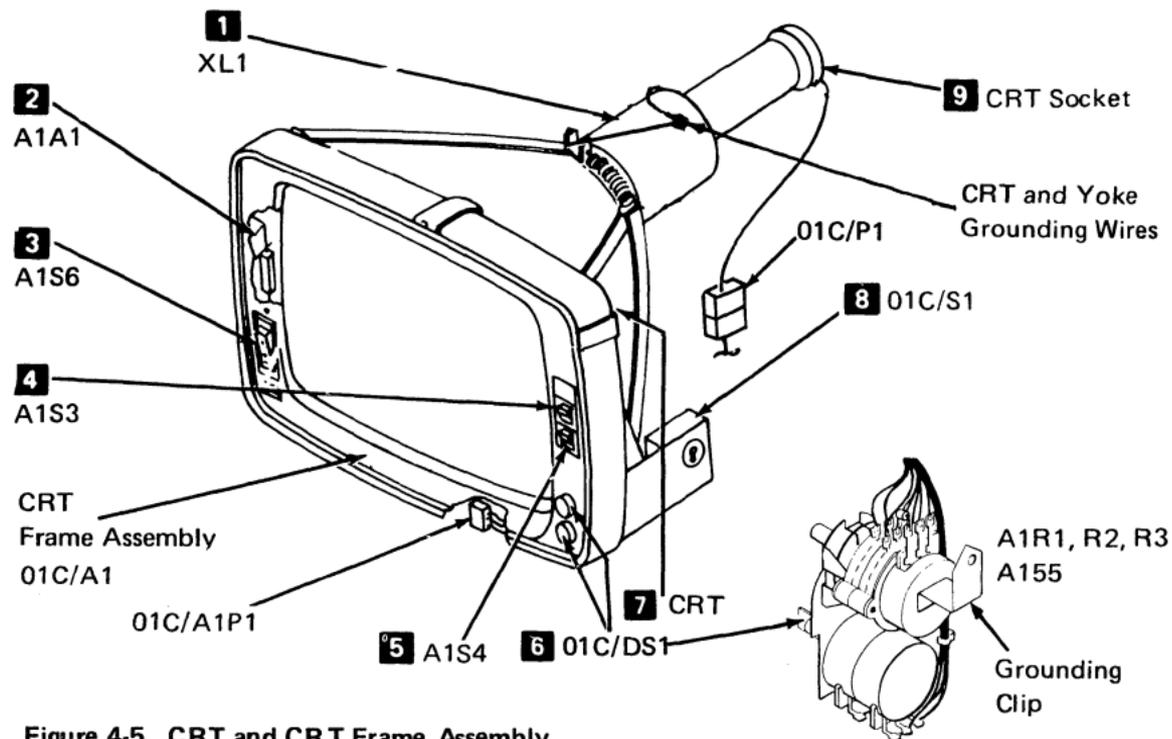
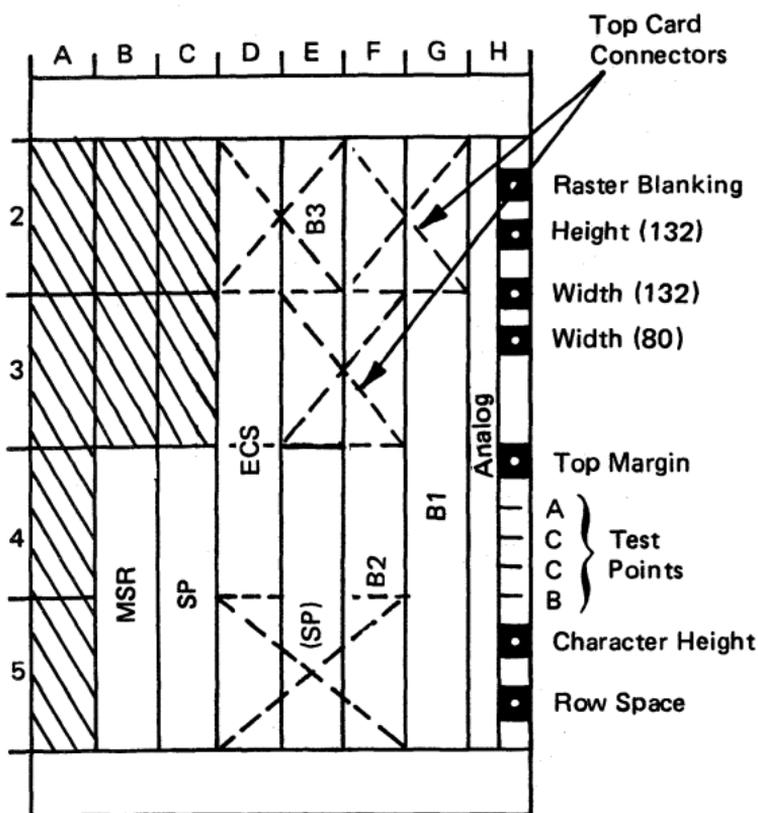

Figure 4-5. CRT and CRT Frame Assembly

Key	Description	PN
1	Yoke	1743090
2	Indicator Card	1743525
3	On/Off Sw	1743178
4	Dual/Mono Sw	1655357
5	Normal/Test Sw	1655357
6	Contrast Pot/Audible Alarm Volume Ctrl Intensity Pot Intensity Override	1743199
7	CRT	1655349
8	Security Key Lock	5214866
9	CRT Socket	1743041



Legend:

- B1 - Base Card 1
- B2 - Base Card 2
- B3 - Base Card 3
- SP - Selector Pen Card (location depends on feature)
- MSR - Magnetic Slot Reader Card
- ECS - Extended Character Set card

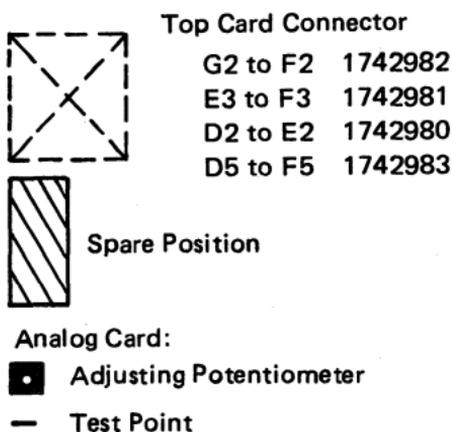
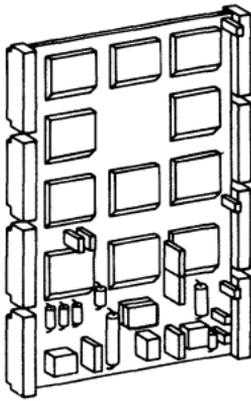
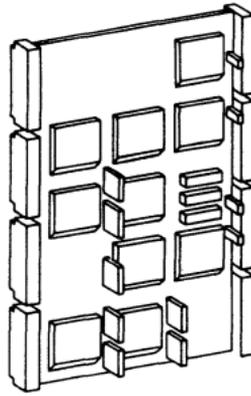

Figure 4-6. Card Locations, (D) Type



Base Card 1



Base Card 2

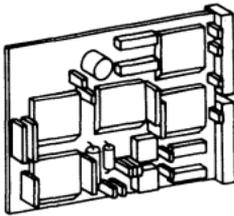

MSR Card

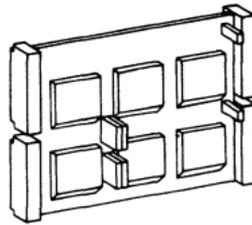

Base Card 3

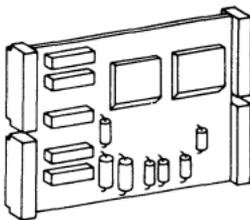

Selector Pen Card

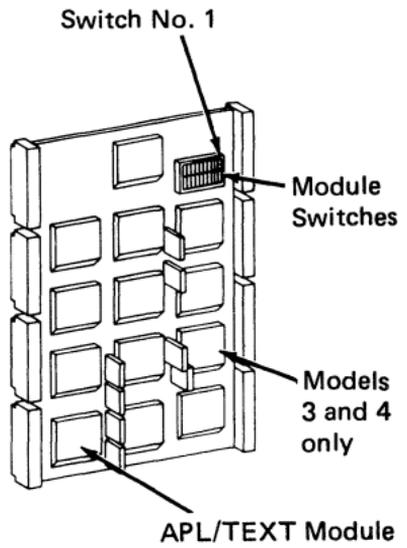

ECS Card

Figure 4-7. Card Illustrations, (D) Type

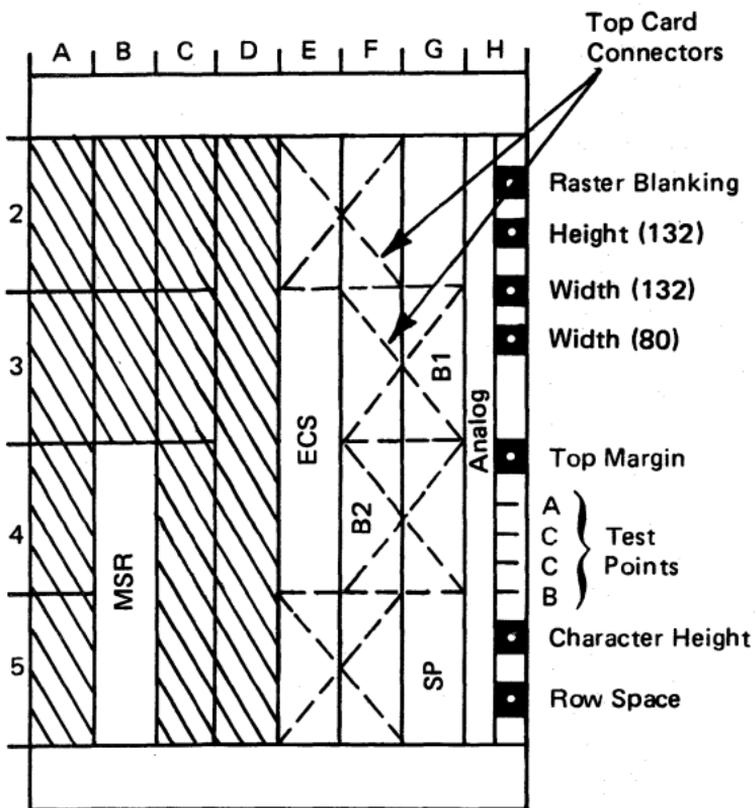

Legend:

- B1 - Base Card 1
- B2 - Base Card 2
- SP - Selector Pen Card (location depends on feature)
- MSR - Magnetic Slot Reader Card
- ECS - Extended Character Set card

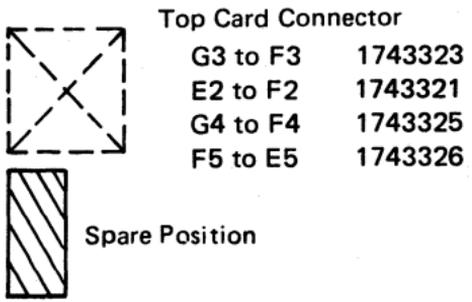

- Analog Card:
- Adjusting Potentiometer
 - Test Point

Figure 4-8. Card Locations, (M) Type

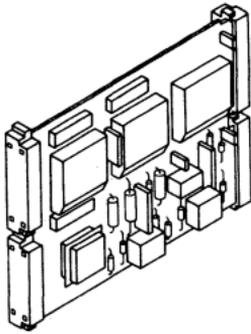

Base Card 1

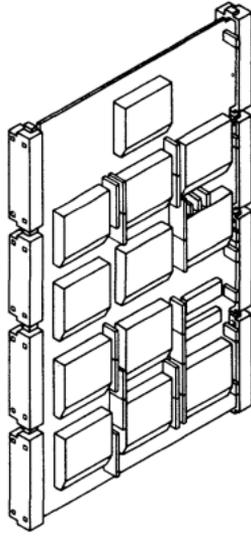

Base Card 2

Figure 4-9. Card Illustrations, (M) Type

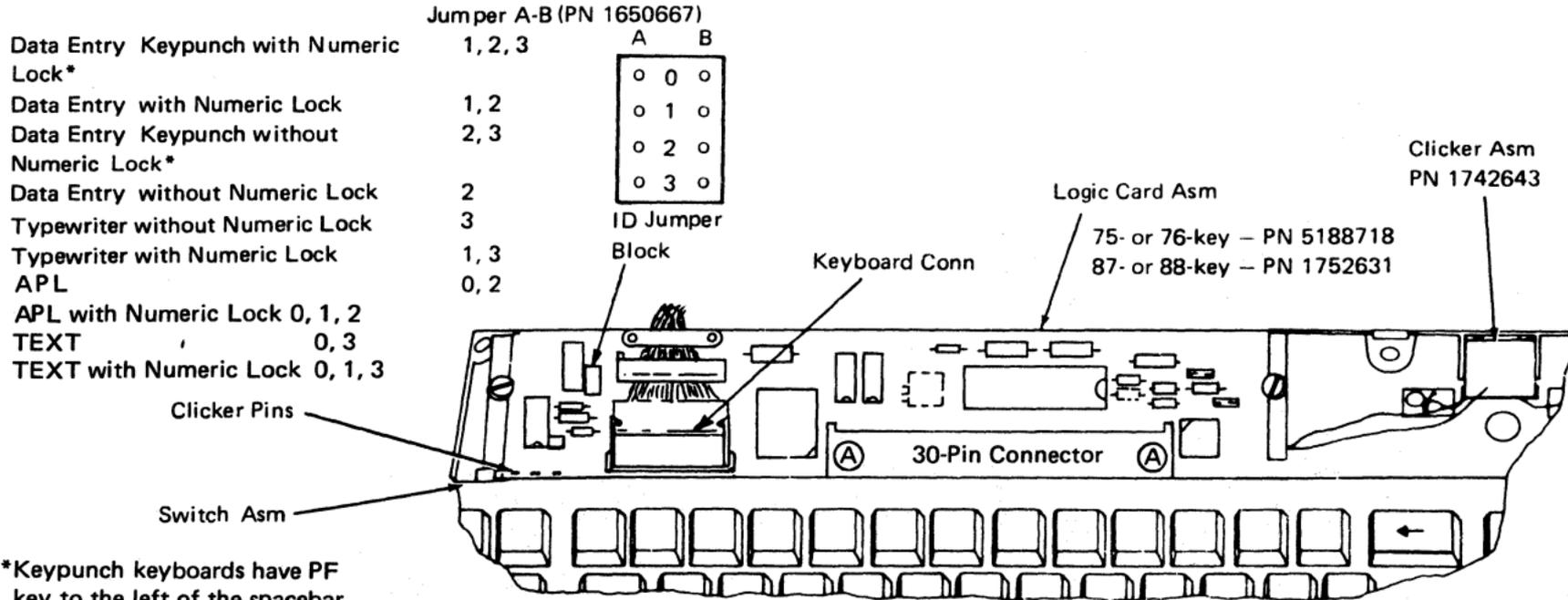
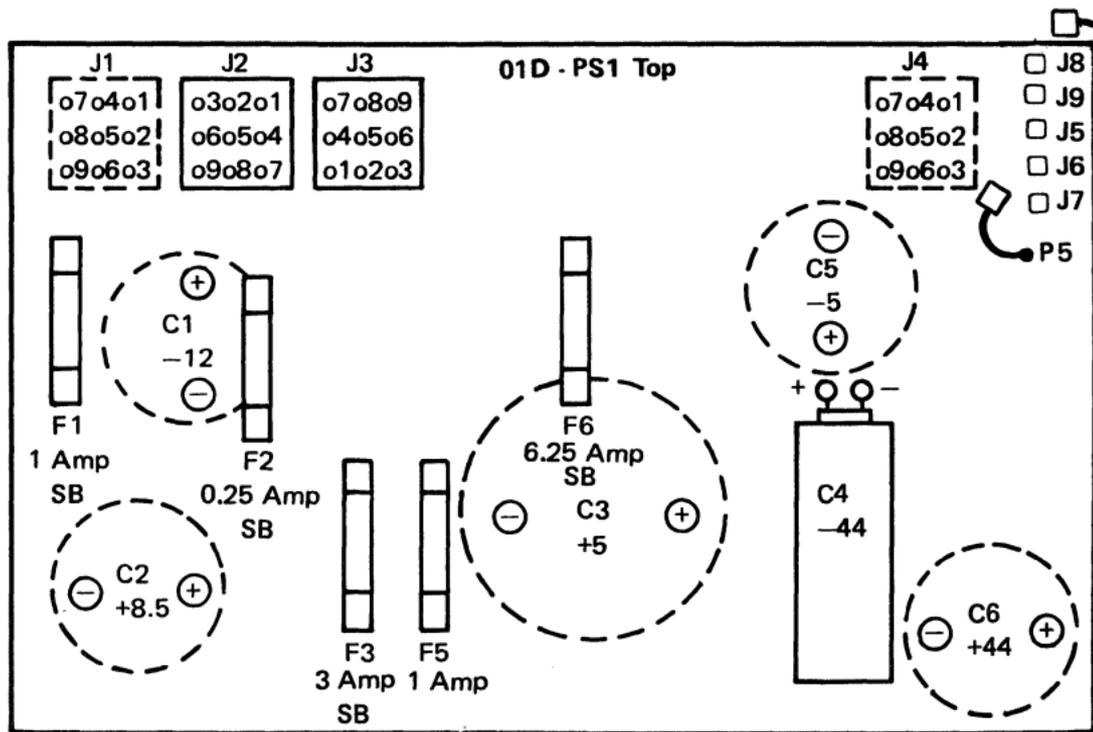

Figure 4-10. Keyboard



Fuses	Voltage	PN
F1	6.3	303549
F2	-12	111261
F3	+8.5	338165
F5	+44	855253
F6	+5	2130253

Slip-On Conn to Ferro

Voltages at J Connectors		Max Ripple (Peak to Peak)
J2 - 1, 4, 7	+8.5 Vdc	0.25 Vac
2	+8.0 V ± 1 V	0.25 Vac
5, 8	-12 Vdc	0.24 Vac
6	DC Return	
3, 9	6.3 Vac and Return	
J3 - 1	-44 Vdc	0.88 Vac
2, 5, 8	+5 Vdc	0.15 Vac
3, 6	-5 Vdc	0.15 Vac
4	+44 V	0.88 Vac
7	DC Return	

Figure 4-11. Fuse Locations – Low-Voltage Power Supply

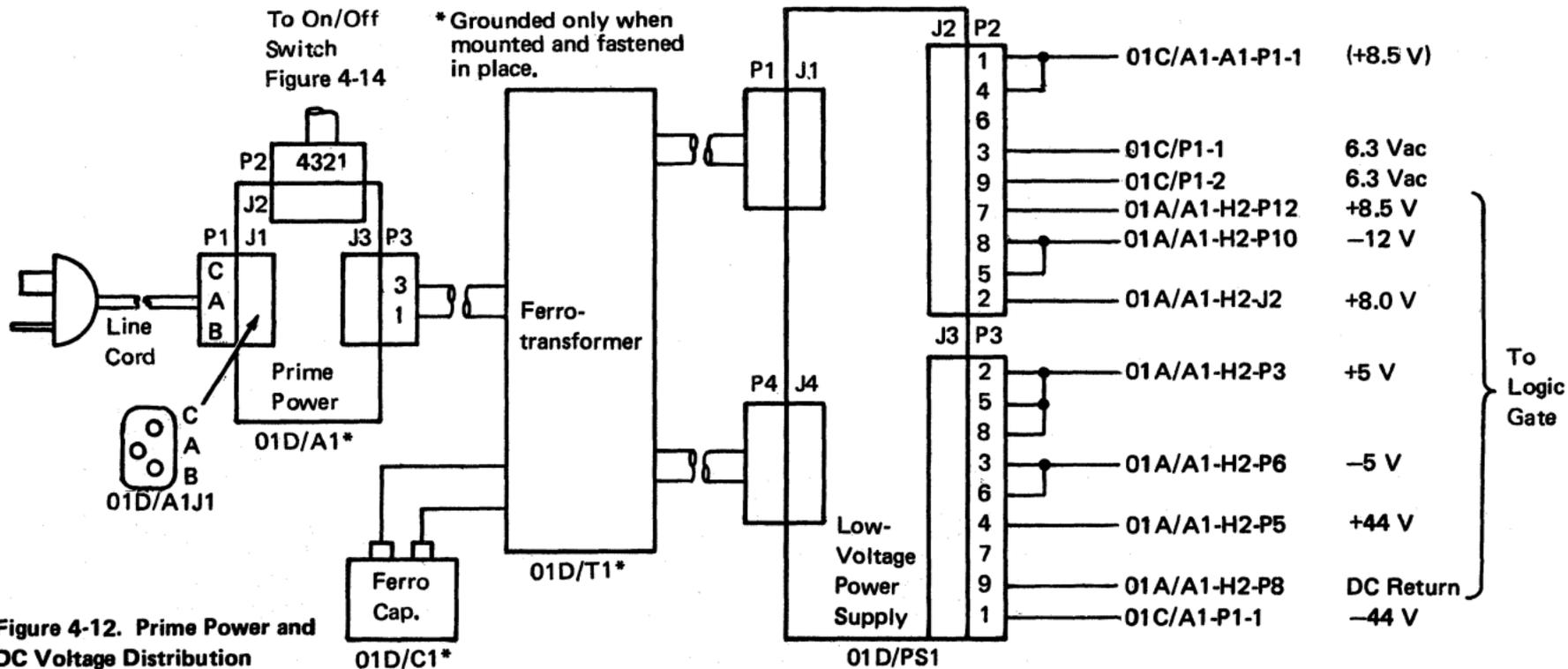

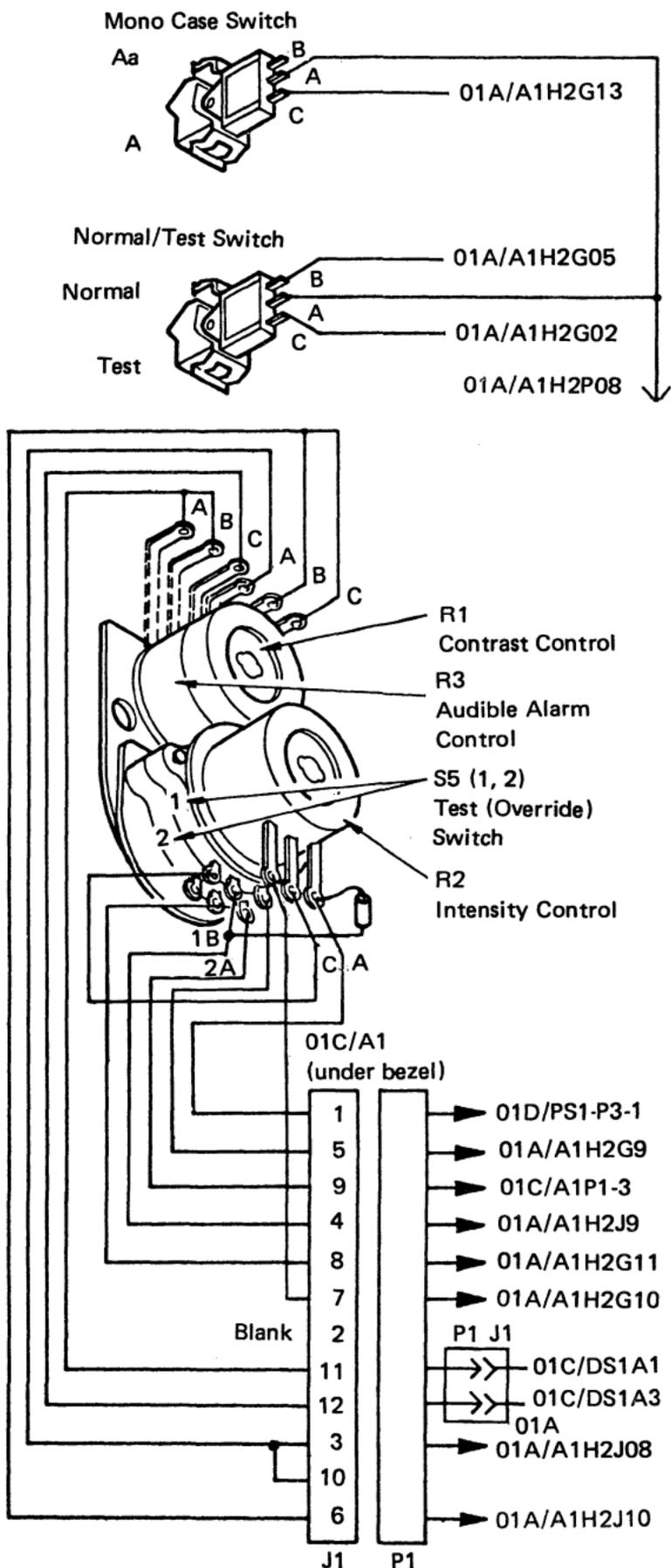

Figure 4-13. Operator Controls

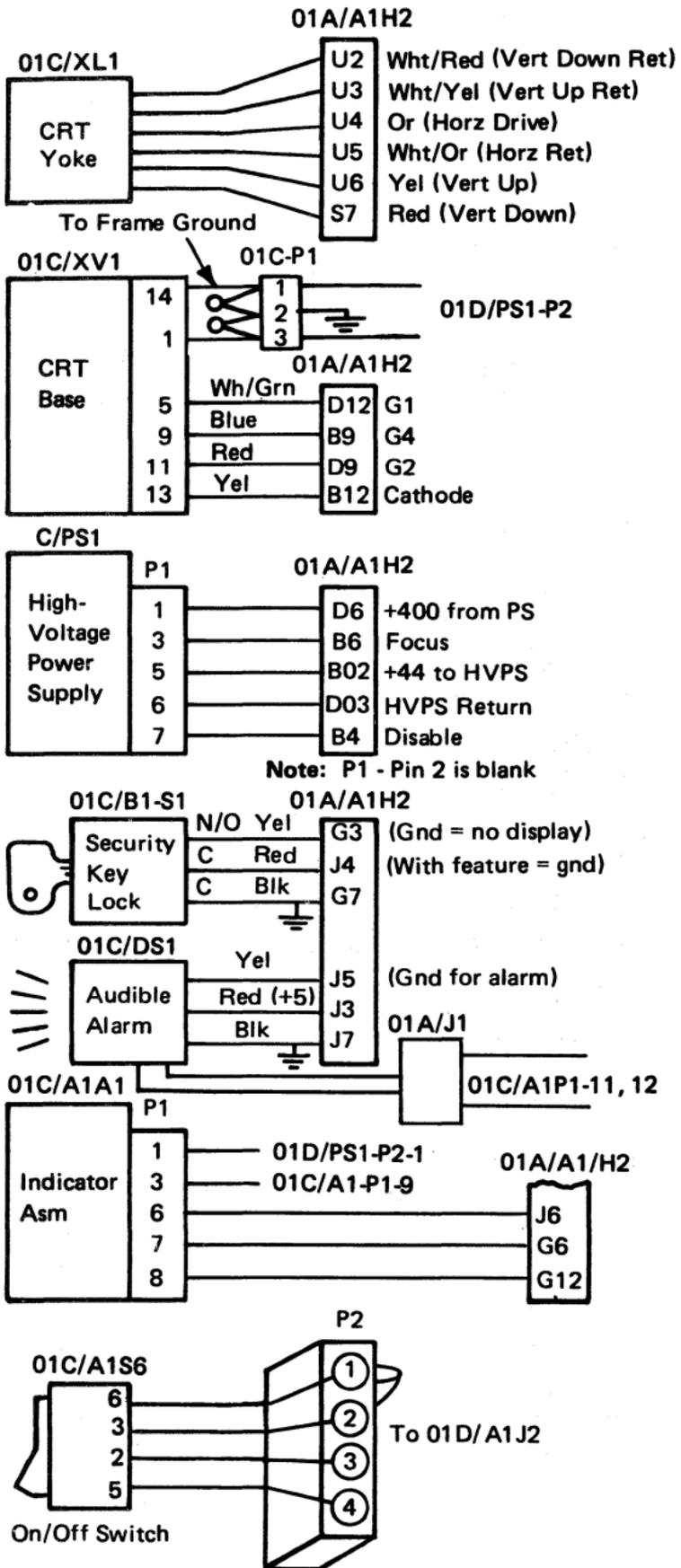

Figure 4-14. Operator Controls and Indicators

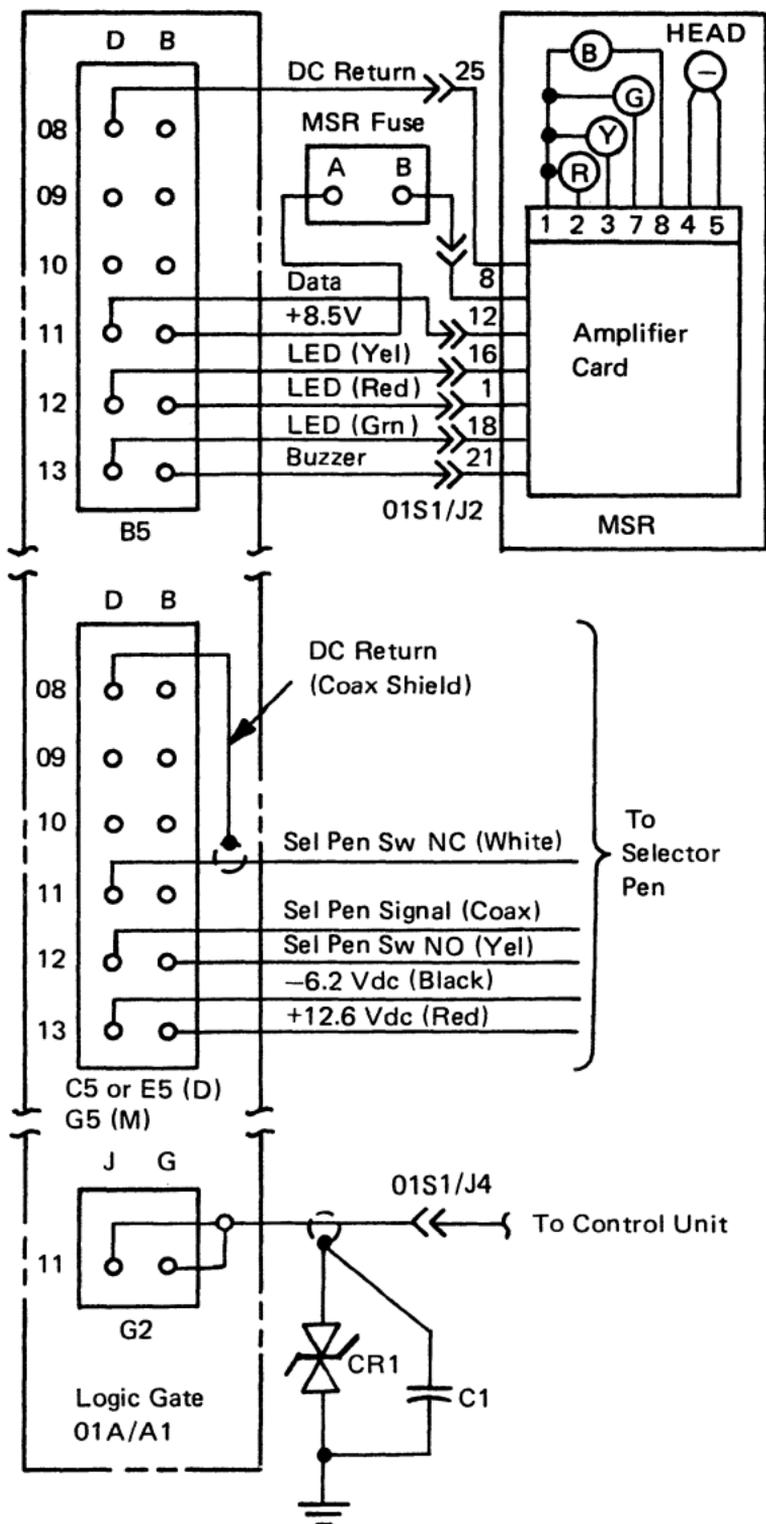
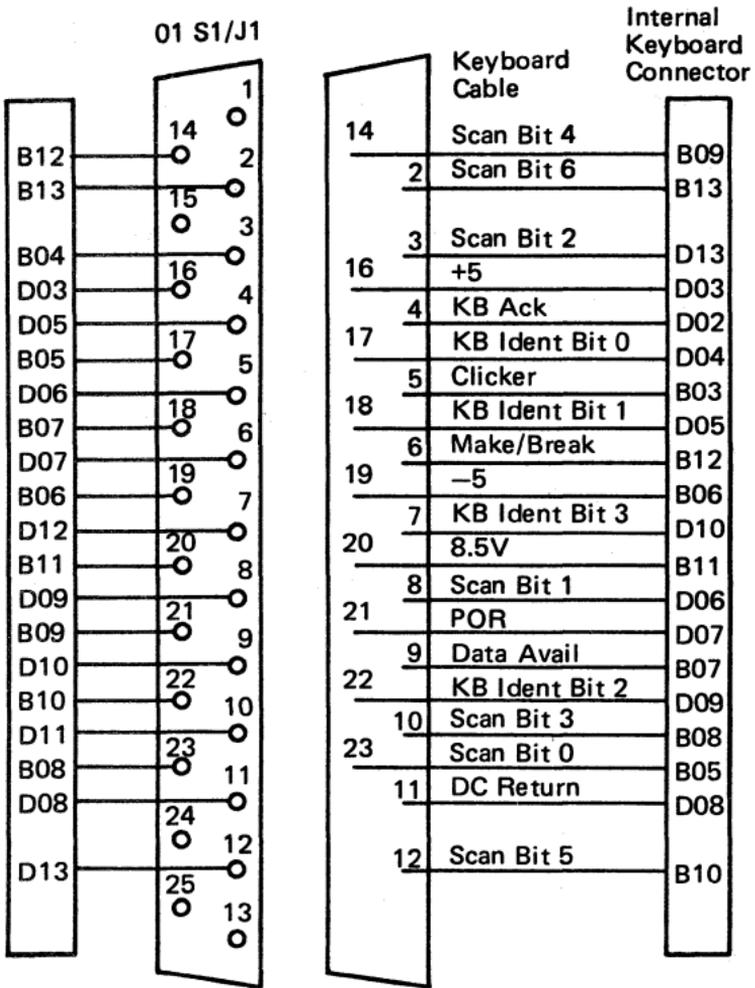
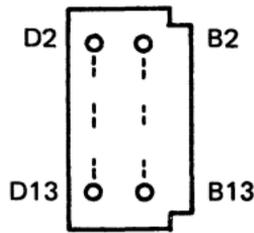

Figure 4-15. Feature Cabling

(M) 01A/A1F5
(D) 01A/A1G5



Keyboard Connector



Plug End View

Probe Points

Line Name	Static	Active
1 Scan Bits 0-6	Down	Pulse up
2 Kybd ID Bits 0-3	Down/Jmpr	Up no jmptr
3 Kybd ACK	Up	Pulse down
4 Clicker	Down	Up click
5 Make/Break	Down	Up pulse
6 POR	Down	Up after POR
7 Data Available	Up	Down pulse

Figure 4-16. Logic Gate to Keyboard Cables

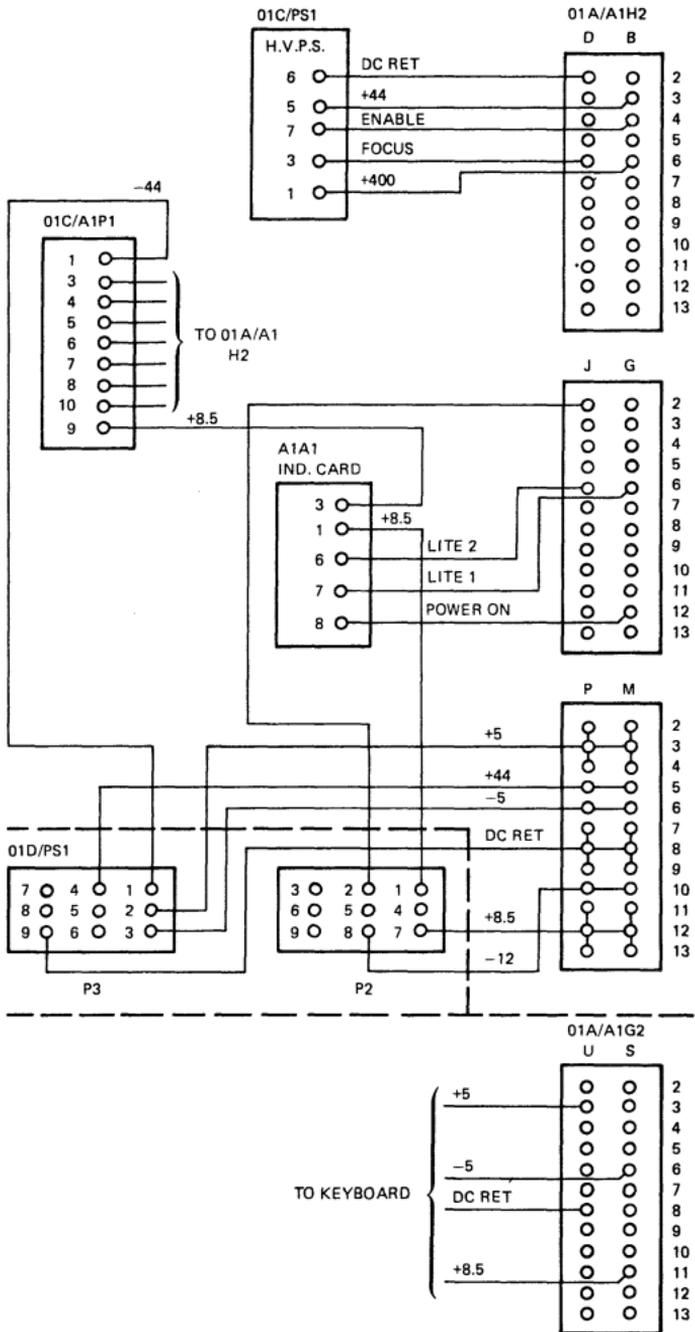

Figure 4-17. DC Power Distribution

Chapter 5. Display Image Adjustments

Before checking the following adjustments, determine that all voltages are within tolerance (see MAP 01, step 028), set the Normal/Test switch to the Test position to display the test pattern, and install the alignment mask (PN 1743248) on the display screen.

5.1 Yoke Alignment and Centering

Disable vertical deflection by installing jumpers on the analog card test points (see Figure 4-6). Jumper test point A to C and C to B, or wrap a bare wire around all four pins. A single horizontal trace should be displayed. This trace should be parallel to, and vertically and horizontally centered on, line 1 on the alignment mask. If the trace is not parallel to line 1, the yoke must be aligned. If the trace is not centered the centering rings must be adjusted (see Figure 5-2). In either case, the CRT cone shield must be removed before the adjustment is made.

5.1.1 Remove Cone Shield. To remove the cone shield, do the following after removing the top and side covers:

DANGER

Switch off the 3278, and then disconnect the power cord.

1. Remove the socket from the base of the CRT (see Figure 5-1).
2. Loosen the cone shield retaining screw (see Figure 5-1), rotate the cone shield counterclockwise until the locking tabs disengage, and pull the cone shield straight back to clear the CRT neck. Do not remove the yoke or yoke shield.
3. Reseat the socket on the CRT base, connect the power cord, and turn the 3278 on.

5.1.2 Yoke Alignment. To adjust the yoke alignment, do the following:

1. Loosen the yoke clamp screw (see Figure 5-2).
2. Rotate the yoke by turning the yoke shield until the horizontal trace is parallel to line 1 on the alignment mask.
3. Be sure the yoke is firmly seated against the CRT bell, and tighten the yoke clamp screw.

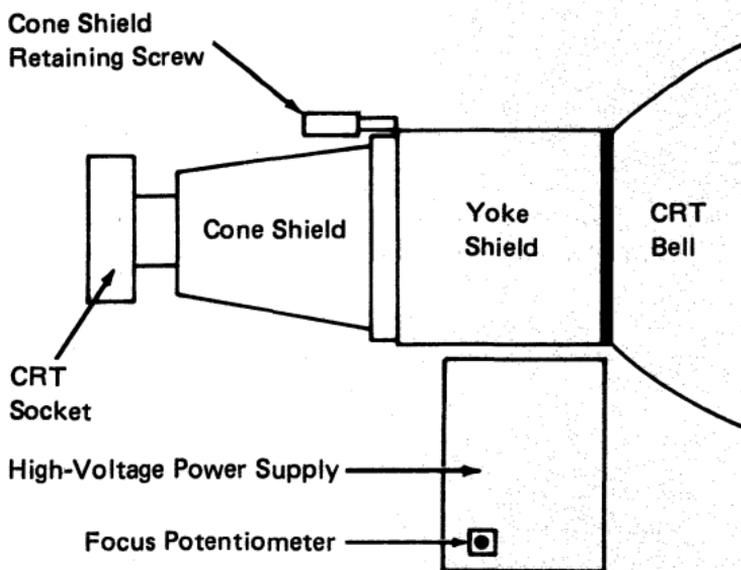

Figure 5-1. CRT and High-Voltage Power Supply

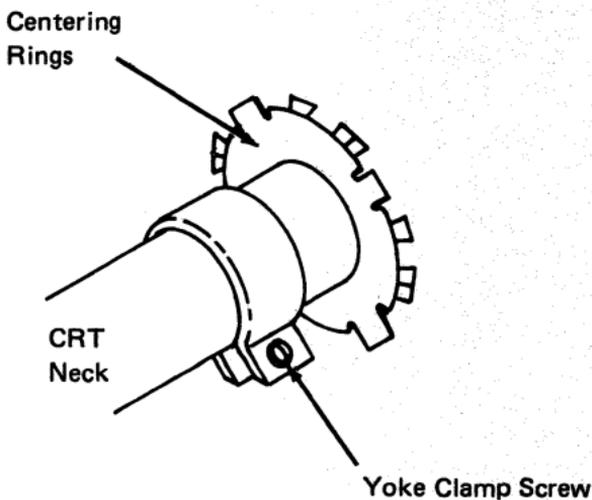

Figure 5-2. Yoke Adjustments

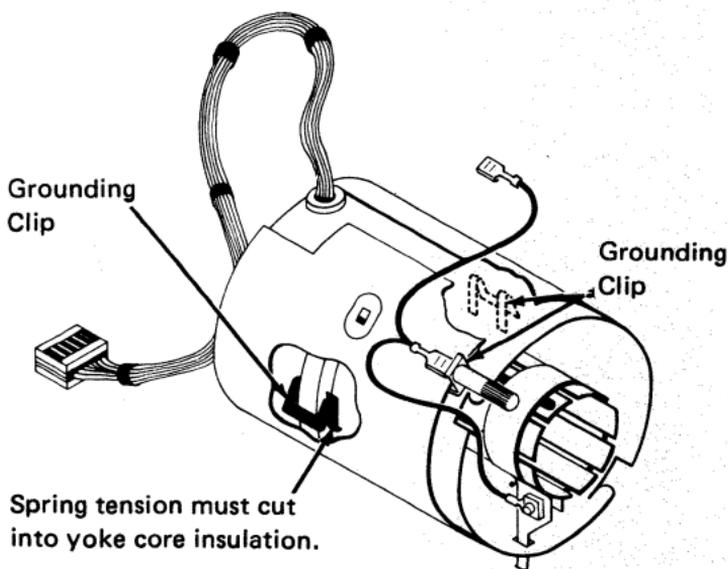

Figure 5-3. Yoke Grounding Clips

5.1.3 Centering and Horizontal Width. Turn the centering rings (see Figure 5-2) to center the horizontal trace, both vertically and horizontally, on line 1 of the alignment mask. The width (length of the horizontal trace) should be 266.7 mm (10.5 inches) as indicated by line 2 on the alignment mask. It may be necessary to adjust the width potentiometer, width (80), on the analog card (see Figure 4-6) together with the centering rings.

5.1.4 Reinstall Cone Shield. When the yoke alignment, centering, and width adjustments are correct, remove the jumpers from the analog card test points and replace the cone shield by reversing the procedure in paragraph 5.1.1.

5.2 Analog Card Adjustments

There are five potentiometers (seven for Model 5) on the analog card (see Figure 4-6) which may need adjustment when the analog card is swapped, or at other times. Check the conditions described in the first paragraph of this chapter before continuing.

1. See paragraph 5.1.3 for a description of the width potentiometer.
2. Install a jumper between pins E02 G04 and E02 J08.
3. Adjust the top margin potentiometer so the top trace of the first character line is centered on line 3 on the alignment mask for the appropriate model.
4. Adjust the character height potentiometer so the bottom trace of the last character line is near the line on the alignment mask for this model of the 3278.
5. Remove the jumper installed in step 2, and adjust the row space potentiometer to obtain the total vertical height of 101.6 mm (4 inches) for a Model 1, or 203.2 mm (8 inches) for all other models (line 7).
6. For Model 5 only:
 - a. Set the display to 132-character width mode. See step 21 of Test Mode 3 in paragraph 3.3.1.3; use normal cursor.

C. Voltage Measured Is Less Than +44 V

1. Switch off the 3278.
2. Connect the jumper to pin J5. (See Figure 4-11.)
3. Switch on the 3278.
4. Measure the voltage at fuse 5 (+) to dc return (-).
5. If the voltage is between +44 and +48 V, the adjustment is completed. Skip the following steps.
6. If the voltage is still less than +44 V, one or more of the following conditions are present:
 - a. The +44 V power supply is defective.
 - b. The ferrotransformer is defective.
 - c. There is a logic or cable short.

D. Voltage Measured Is Greater Than +48 V (with jumper connected to pin J6)

1. Switch off the 3278.
2. Connect the jumper to pin J7.
3. Switch on the 3278.
4. Measure the voltage at fuse 5 (+) to dc return (-).
5. If the voltage is between +44 and +48 V, the adjustment is completed. Skip the following steps.
6. If the voltage is still greater than +48 V, go to step E.

E. Voltage Measured Is Greater Than +48 V (with jumper connected to pin J6)

1. Switch off the 3278.
2. Connect the jumper to pin J9.
3. Switch on the 3278.
4. Measure the voltage at fuse 5 (+) to dc return (-).
5. If the voltage is between +44 and +48 V, the adjustment is completed.
6. If the voltage is still greater than +48 V, one or more of the following conditions may be present:
 - a. The +44 V power supply is defective.
 - b. The ferrotransformer is defective.
 - c. There is a logic or cable short.

Chapter 6. Removals and Replacements

6.1 Covers

All removal and exchange procedures require that the desired unit be made accessible by removing the correct covers. You may leave the top cover on the display station while performing many maintenance procedures. This protects the CRT by partially covering it.

1. **Front cover:** Push backward on the latch at the top center. The cover moves forward at the top while pivoting on two pins at the bottom. Lift the cover off the pins.
2. **Side covers:** Before removing the right side cover, remove the security key, if it is inserted. Pull the front pin (under the front of the side cover) toward the front of the display. When the pin reaches the limit of movement, pivot the rear edge of the cover slightly away from the base and top cover. Lift the cover from the display station. The WTC side covers use a rear retainer spring that prevents movement of the front pin. Release the spring by using a screwdriver on the spring.
3. **Top/rear cover:** The top/rear cover can be removed only after both side covers are removed. Pull out the spring-loaded knobs at the lower right and lower left of the top cover and pivot up. Pull the top cover back slightly to disengage it from the guides in the CRT frame. Carefully lift the cover off the display station.

6.2 Power Units

DANGER: All power unit removal and exchange procedures must be performed with power off and with the power cord disconnected at the wall outlet (Switch off power before disconnecting the plug.)

6.2.1 Low-Voltage Power Supply

1. Remove the low-voltage shield by loosening the screw at the center of the shield.
2. Disconnect the two cable connectors installed in the front of the low-voltage supply (P2-P3), and disconnect the slip-on connector from the tab located at the upper-right corner of the assembly. See Figure 4-11.

3. Remove the screw holding the assembly to the lower frame. (The screw is located at the bottom center of the assembly.)
4. Slide the assembly partially from the display station, and disconnect the two cables connected on the back of the assembly.
5. Slide the assembly from the display station.
6. Reinstall in the reverse sequence.
7. Use the adjustment procedure in paragraph 5.4 for the +44 V power supply.

6.2.2 AC Capacitor

1. Holding the insulated handle of a screwdriver, short out the capacitor terminals with a metal shaft to discharge the capacitor.
2. Remove the rubber cover from the top of the capacitor (see Figure 4-3), and slide it back on the wire leads.
3. Pull the two leads from the capacitor terminals.
4. Pull the capacitor from the spring holder.
5. Reinstall in the reverse sequence. (This capacitor has no polarity.)

6.2.3 Prime Power Box

1. Disconnect the cable connectors plugged into the rear and top of the prime power box (see Figure 4-3).
2. Remove the ac capacitor as described in paragraph 6.2.2.
3. Disconnect the line cord from the receptacle if not previously done.
4. Remove the two screws holding the prime power box to the front of the frame.
5. Remove the assembly from the machine.
6. Reinstall in the reverse sequence.

6.2.4 Ferrotransformer

1. Remove the low-voltage power supply shield.
2. Remove the leads from the ac capacitor as described in paragraph 6.2.2.
3. USA/Canada: Remove the ferro connector from the prime power assembly.

4. WT except Canada: Disconnect the two wires (two screws) leading from the ferro terminal strip to the prime power assembly. Note where the leads are connected for reinstallation.
5. EMEA ferrotransformer only: Remove the screw fastening the ground wire (green/yellow) from the side of the prime power assembly.
6. Disconnect the two cable connectors and slip-on connector from the ferrotransformer to the low-voltage assembly.
7. Remove the outer mounting screw holding the ferro to the frame and loosen the inner screw.
8. Slide the transformer out of the frame.
9. Reinstall in the reverse sequence.
10. Check the +44 V supply using procedure 5.4.

6.2.5 High-Voltage Power Supply

1. Using an insulated jumper wire, ground the CRT anode terminal to discharge static charge. Carefully disconnect the CRT anode lead; static charge may be present.
2. Disconnect the input cable at the lower edge of the high-voltage assembly (see Figure 4-4).
3. Open the logic gate by loosening the front mounting screw located in back of the high-voltage supply support shield.
4. Remove the high-voltage supply mounting screw located on the back of the high-voltage support shield.
5. Slide the power supply out of the support shield.
6. Reinstall in the reverse sequence. Ensure that the anode lead is firmly seated on the CRT bell.

6.2.6 Fuses

1. Fuses are located near the line-voltage cord socket and under the low-voltage shield.

6.2.7 Card/Connector Removal and Replacement Procedures. All cards and internal connectors (except the CRT socket) have mechanical locking devices.

6.2.7.1 Internal Connectors

Removal – Pinch the latch tabs together, and pull the connector free from the pins.

Exchanging – Reseat the connector, and ensure that the tabs are latched.

6.2.7.2 Internal Coax

Removal – Press and hold the latch button, and pull the connector free from the pins.

Exchanging – Reseat and ensure that the connector is latched.

6.2.7.3 Cards

Removal – Unlock and rotate the extractor levers simultaneously at the top and bottom until the card disengages.

Exchanging – Open both extractor levers fully.

Insert the card holder tracks into the front guide fingers (card components towards hinge). Push in until the card holder tracks engage the rear fingers. *Do not use the extractor levers to reseat the card.* Apply firm finger pressure to the card holder (or connector housing for double-ended cards) to ensure proper contact seating.

After reseating, press firmly on the indicated surface of both extractor levers (top and bottom) and rotate simultaneously in the direction shown until latched.

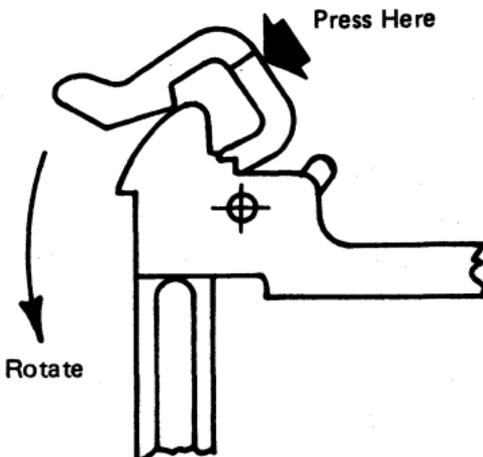

6.2.8 Circuit Board Segments

1. Disconnect all the cabling at the gate.
2. Remove the top and the bottom board mounting screws.
3. Pull the outermost stiffener straight out until it is free of the alignment pins.
4. Remove the affected circuit board segment(s) by inserting the guide pins into the alignment holes in the inner stiffener, starting in card column "H". Ensure that the numerals and "This Side Out" (pin side) face out and that the "arrows" point upward. Seat the segment(s) firmly into all the card connectors.
5. Reinstall the outer stiffener over the alignment pins with the numeral "2" at the top and the "arrows" pointing upward.
6. Reinstall the mounting hardware and ensure that the card holders are equally centered in the gate opening; then tighten the screws and reinstall the cabling.
7. Check by using procedure 3.3.1 through step 2 of 3.3.1.3 (Test Mode 3) and procedure 3.3.2.2.

6.3 CRT

DANGER

All persons touching a CRT or near a CRT that is not protected must have eye and arm protection (that is, eye shields and long sleeves).

1. Disconnect the power cord at the wall receptacle.
2. Remove the left, right, and top covers.
3. Open the logic gate by loosening the front mounting screw located in back of the high-voltage supply.
4. On units with the security keylock feature:
 - a. Mark the location of the keylock assembly mounting bracket on the side of the frame.

- b. Remove the screws holding the bracket to the frame.
 - c. Place the keylock assembly to give access to the lower-right CRT holding nut.
5. Using an insulated jumper wire, ground the CRT anode to discharge electricity.
6. Carefully disconnect the CRT anode lead. There may be an electric charge on the anode.
7. Disconnect the CRT socket ground lead from the CRT bell ground strap, located in front of the yoke assembly.
8. Remove the socket from the end of the CRT.
9. Remove the cone shield from the end of the CRT:
 - a. Loosen the cone shield retaining screw.
 - b. Turn the cone counterclockwise until the locking tabs disengage.
 - c. Pull the cone shield straight back and free of the CRT.
10. Remove the yoke ground wire from the CRT bell ground strap.
11. Loosen the yoke clamp screw, slide the yoke assembly off the CRT, and place it on the upper frame.
12. Open the new CRT container, and place the pad on a stable surface near the display station to support the old CRT when it is removed.

Caution: The following steps free the CRT from its mounting. The CRT weighs about 7.25 kg (16 pounds). Protect and support the CRT from too much pressure, which could damage the CRT or other units.

13. Remove the CRT holding nuts (4).
14. With the CRT resting on the mounting studs, carefully remove the grounding straps.
15. Connect the lifting strap (supplied with the new CRT) to the top CRT mounting tabs.
16. Carefully slide the CRT toward the rear of the display station and lift it from the unit.
17. Place the CRT face down on the pad.
18. Install the new CRT in the reverse sequence.

19. When tightening the CRT mounting nuts, ensure that the ground strap is flat against the CRT bell and under the spring. Gradually tighten the nuts, alternating from nut to nut until all are fully tightened.
20. See that the yoke cable is located at the top when replacing the yoke assembly.
21. Perform all display station image adjustments (see Chapter 5).
22. Tighten the yoke mounting screws after adjustments.

6.4 Yoke and Shields

The yoke and shield assemblies are removed from the CRT neck as a unit. After the assemblies are removed, they can be separated.

Note: *The top and rear covers must be removed, and the logic gate must be opened.*

1. Disconnect the yoke cable from the gate, and disconnect the ground wire(s) from the CRT bell ground strap.
2. Cut the yoke cable fasteners on the logic gate, and support. Disconnect the CRT socket ground lead from the CRT bell ground strap, located in front of the yoke assembly.
3. Remove the socket from the base of the CRT.
4. Remove the cone shield from the base area of the CRT:
 - a. Loosen the shield retaining screw.
 - b. Turn the cone shield counterclockwise until the locking tabs disengage.
 - c. Pull the cone straight back and clear of the CRT.
5. Loosen the yoke clamp, and carefully slide the assembly off the CRT.
6. Remove the clamp from the centering magnet assembly.
7. Separate the yoke from the shield by pressing the plastic tabs (4) located around the shield circumference, and slide the yoke forward (away from the clamp).

8. Remove the two grounding clips, noting the positions of these clips, and install them in the same positions on the new yoke.

Caution: Do not cut into the yoke wiring with the clips. Also ensure that the clips are cutting through the white insulation coating on the yoke core.

9. Before removing the centering magnet assembly from the yoke, note the orientation of the centering magnet assembly guides in relation to the split in the yoke windings. This assembly must be reinstalled with the assembly guides in the same orientation or the yoke wiring will not be positioned properly when installed in the shield. Remove the centering magnet assembly by lifting the four plastic tabs, and install them on the new yoke with the same orientation that they had on the old yoke.

Caution: Ensure that the centering magnet assembly guides are lined up with the split in the yoke winding.

10. Reinstall in the reverse sequence.
11. See that the yoke cable is located at the top when replacing the yoke assembly.
12. Push the yoke tightly against the CRT bell when tightening the yoke clamp. Do not tighten the screw fully until after the adjustments have been made.
13. Perform all the display image adjustments (see Chapter 5).
14. Tighten the yoke mounting screw fully after the adjustment.

6.5 Operator Controls

Operator controls are mounted to the CRT mask assembly. The mask assembly must be removed to replace any of the following controls.

6.5.1 CRT Frame Assembly

1. Remove the side and top covers.
2. Disconnect the On/Off switch cable connector from the top of the prime power box and remove the rubber cable retainer.
3. Remove the two screws from the upper rear of the CRT support.
4. While pulling the mask forward, press the plastic tabs located under the top cover ground spring, near the on/off switch, and near the intensity control.
5. Pivot the mask down in front of the unit.

6.5.2 On/Off Switch

1. Remove the rubber clamp from the cable clamp.
2. Press the plastic catch at the rear of the switch to one side, and pull the switch out.

6.5.3 Intensity and Contrast Controls

1. Pull off the two knobs and spacer or the audible alarm knob.
2. Disconnect the connector, and slip it out of the fasteners.
3. Expand the spring clips (2) with a screwdriver, and pull the control assembly off the pins.

6.5.4 Indicator Card Assembly

1. Remove the screw with spring.
2. Remove the connector and card assembly.

6.5.5 Switches

1. Remove the cable connectors. (Note where the leads are connected for reinstallation.)
2. Press the spring latch, and remove the switch.
3. Reinstall in the reverse sequence.

6.6 Optional Features

6.6.1 Audible Alarm

The audible alarm circuits are in a small metal box on the logic gate.

1. Remove the audible alarm box from the gate by loosening the mounting screws.
2. Remove the circuit board from the metal box.
3. Remove the cable wires from the audible alarm circuit board with longnose pliers or with a small screwdriver.
4. Reinstall in the reverse sequence. The circuit board is marked with the color code of wires to be connected.

6.6.2 Security Keylock

1. Remove the screws that hold the keylock assembly to the frame.
2. Remove the keylock assembly cover.
3. Remove the cable leads from the switch with pliers or with a small screwdriver. Note the terminals from which the leads are removed (for later connection).
4. Remove the cable fastener from the hole in the switch assembly.
5. Remove the cable from the keylock assembly.
6. Reinstall in the reverse sequence. Be sure to align the keylock assembly with the hole in the right side cover.

6.7 Keyboard Units

This section describes the procedures for removing and reinstalling the keyboard units. The following equipment may be required:

- | | | |
|--------------------|---|--|
| Keytop puller tool | - | PN 9900373 (preferred),
PN 75475, or PN 627953 |
| Isopropyl alcohol | - | PN 2200200 (or IBM tape
transport cleaner -
PN 453511) |
| Cloth (lint-free) | - | PN 2108930 (or tissue -
PN 2123106) |

6.7.1 Keyboard from Display Station

1. Switch off power.
2. Remove the display station front cover.
3. Remove the cable ground wing nut from the frame.
4. Free the cable fastener, and remove the keyboard cable connector from its socket.
5. Reinstall in the reverse sequence.
6. Ensure that all cable connectors are tightly seated in the sockets and that the ground straps are attached.

6.7.2 Keyboard Top Cover

1. Invert the keyboard.
2. Remove the four screws in the corners of the keyboard base.
3. Place the keyboard base on a flat surface.
4. Lift the top cover off the keyboard.
5. Reinstall in the reverse sequence.

Note: *Check for cover clearance around the keys after the cover has been reinstalled. Adjust if required.*

6.7.3 Keyboard Assembly from Base

1. Switch off power.
2. Disconnect the keyboard from the display station. (See par. 6.7.1.)
3. Remove the keyboard top cover. (See par. 6.7.2.)
4. Disconnect the keyboard cable connector and clicker connector at the logic card.
5. Remove the two screws that hold the keyboard assembly to the mounting. (Mark for alignment reference.)
6. Lift the keyboard assembly off the mounting and remove the logic card assembly from the keyboard per paragraph 6.7.8.
7. Reinstall in the reverse sequence.
8. Ensure that the cable connector is tightly seated.

6.7.4 Clicker Assembly

1. Switch off power.
2. Disconnect the keyboard from the display station. (See par. 6.7.1.)
3. Remove the keyboard top cover. (See par. 6.7.2.)
4. Remove the keyboard assembly from the base. (See par. 6.7.3.)
5. Disconnect the clicker connector.
6. Remove the clicker assembly by sliding the bail fastener from under the cast tabs.
7. Reinstall in the reverse sequence.

6.7.5 Keybutton

Remove buttons by sliding the keytop puller tool over the keytop and pulling straight up.

6.7.6 Key Module

The work area must be clean during work on the keyboard. Any particle between the key module flyplate and the printed circuit is a possible problem.

1. Switch off power.
2. Disconnect the keyboard from the display station. (See par. 6.7.1.)
3. Remove the keyboard top cover. (See par. 6.7.2.)
4. Remove the keybutton from the module that will be swapped. (See par. 6.7.5.)
5. Remove the keyboard assembly from the base. (See par. 6.7.3.)
6. Invert the keyboard, and place it on the base pins located on the left and right sides.

6.7.6.1 Key Module Removal (Including Spacer Module)

Note: See par. 6.7.7A, *Spacebar Removal, if the spacebar module is to be swapped.*

1. Remove the screws that hold the base plate and circuit board to the all-keys assembly.

2. Lift the circuit board from the all-keys assembly, and place the circuit board on its base in a clean area.
3. Handle the all-keys assembly by the sides. Be careful not to press any keys. Lift the all-keys assembly off the base, turn it over, and place it on the base.

Note: *Swap the key module if the flyplate comes off. Do not attempt to repair the module. Repaired modules can cause intermittent failures.*

4. Press down on the key module until it is free of the holding plate.
5. Lift the edge of the all-keys assembly nearest the key module that has just been removed. Remove the bad module.
6. Lift the all-keys assembly by the edges, and invert it on its base.

6.7.6.2 Key Module Replacement

1. Ensure that the alignment tab and the angled key-stem are in the same position as those of the other modules in the all-keys assembly.
2. Install the new module (PN 1748131) by pressing the key module into the holding plate by hand.
3. Clean the printed circuit board by carefully wiping it with a lint-free cloth moistened with isopropyl alcohol. Inspect all key module flyplates for any foreign matter, and carefully clean if needed.
4. Align the holding screw holes through the base-plate, circuit board, insulator, and top insulator (if used). Lower the circuit board assembly on the all-keys assembly. Secure the circuit board to the all-keys assembly with the holding screws.
5. Reinstall the keyboard assembly on the base, maintaining its original alignment.
6. Reinstall the keybutton in the correct location.

7. Reinstall the keyboard cable connector and clicker cable to the logic card. Reinstall the keyboard top cover, and reconnect the keyboard to the display if it was removed.
8. Use test mode 2 to check for correct operation of the keyboard.

6.7.7 Spacebar

Perform the removals described in pars. 6.7.1 and 6.7.2 for access to the keyboard assembly.

A. Spacebar Removal

1. Hold the spacebar button at each end (beyond the modules), and remove by pushing upward evenly.
2. Remove pivots (if necessary) by pushing with a screwdriver in the slot in the side of the pivot.

B. Spacebar Exchange

1. Press any pivots removed in step 2 (above) into the mounting frame.
2. Place the spacebar button on its modules, and lower it into position while engaging the bar in the two pivots.
3. Press down on the spacebar at the spacebar modules to seat the spacebar button.
4. Check the spacebar operation for binds. If it binds, the probable cause is a bent right module stem. This stem can be shaped to free the bind.
5. Install the keyboard top cover, and reconnect the keyboard to the display if it was previously removed.

6.7.8 Logic Card Assembly

1. Disconnect the keyboard from the display station.
2. Remove the keyboard top cover. (See par. 6.7.2.)
3. Disconnect the keyboard cable connector and clicker connector at the logic card.
4. Remove the two holding screws from each end of the logic card.

5. Remove the logic card by pressing outward on each end of the 30-pin connector housing (points A in Figure 4-10).

Reinsert the card by applying pressure inward on the same area of the 30-pin connector housing as for removal.

Note: *Always remove and insert the logic card by applying pressure to the 30-pin connector housing. Do not pull, tilt, or press on the card area.*

6. Reinstall in the reverse sequence.

Note: *Check that the keyboard ID jumpers on the new logic card are in the same positions as on the old logic card. See Figure 4-10.*

6.8 Selector Pen

1. Switch off the unit.
2. Hold rear portion of barrel and light-pen cord in one hand. Unscrew cone-shaped tip counter-clockwise to remove the lens assembly.
3. Reinstall the lens assembly, and screw the cone-shaped tip clockwise to reassemble the light pen.

Caution: **Do not overtighten the cone-shaped tip when reassembling.**

Chapter 7. Magnetic Slot Reader Information

The magnetic slot reader (MSR) is a table-top or wall-mounted device used to read data encoded on different types of magnetic striped documents, such as adhesive labels on card stock, tags, and plastic cards. An audio beeper and three light indicators present MSR feedback information to the operator.

The MSR components are packaged in a rugged, plastic housing which has a slot that serves as the document path. The repair and maintenance of the MSR is a customer responsibility.

The MSR may not read magnetic stripes accurately if the stripes contain any of the following defects: tears, scratches, contaminants, demagnetized areas, wrinkles (surface irregularities), and voids.

Head element cleaning is performed by the customer as required. The recommended method of cleaning is to wipe the element with a cloth wetted with isopropyl alcohol. Refer the customer to the *MSR/MHS Replacement Procedure* manual, GA24-3663.

Glossary

The terms defined in this glossary apply to the 3278 Display Station and its attachment to the 3274 and 3276 Control Units.

Analog card: A circuit card that converts digital information into high-level signals for writing characters on the display screen.

Attribute: A byte of data that specifies the kind of display field. An attribute can specify the field as protected or unprotected, for numeric, alphanumeric, intensity, selector-pen detectability, and modification.

Bell: The sides of the cathode-ray tube (CRT) between the display screen and the neck. (See Figure 5-2.)

Blanking: The ability to prevent writing on the screen.

Clicker: An assembly that, when enabled, generates a small sound when a key on the keyboard is pressed. The sound indicates to the operator that the keyboard has recognized the key pressed.

Coax: A shielded cable containing a single conductor.

Cone shield: A shield mounted on the neck of the CRT. (See Figure 5-1.)

Contrast: The difference in light intensity between displayed characters.

Cursor: An underscore symbol that identifies a character position in a screen display, usually the character position at which the next character to be entered from the keyboard will be displayed.

(D): The logic type using three base cards. (See Figures 1-1, 4-6, and 4-7.)

Divider scan: The straight line that is continuously written on the display screen above the bottom line. (See Figure 3-1.)

Dual intensity: The ability to have two levels of brightness for the characters displayed on the display screen.

Ferro: The ferrotransformer. (See Figure 4-3.)

Filament: An internal part of the CRT, located in the neck, that glows when voltage is applied.

Flyplate: The part of the key module, suspended on springs, that snaps on the circuit board when the keybutton is pressed.

Handrest: The part of the keyboard cover where the heel of the hand can be placed for greater ease in entering data and operating the repeat-action keys.

Keybutton: The molded keytop that is installed on the keystem.

(M): The logic type using two base cards. (See Figures 1-2, 4-8, and 4-9.)

Mask: The frame surrounding the display screen. (See Figure 4-5.)

Neck: The narrow portion of the CRT between the bell and the CRT socket. (See Figure 5-1.)

Prime: The compartment where the power cord is attached to the display station.

Raster: The visual sweep of the electron beam on the display screen. The raster is normally present only when the intensity control is in the override position.

Security Keylock: A key-operated switch that allows use of the display station.

Sweep: A single movement of the electron beam, either vertically or horizontally, on the display screen.

Top card connector: A connector that is used to provide additional connections between two or more logic cards that have connectors on the edge of the card opposite the card base.

Yoke: The deflection coil assembly that is installed on the CRT neck. (See Figures 4-5 and 5-1.)

READER'S COMMENT FORM

**3278 Display Station
Models 1, 2, 3, 4, and 5
Maintenance Information**

SY27-2510-4

Please comment on the usefulness and readability of this book, suggest additions and deletions, and list specific errors and omissions (give page numbers). All comments and suggestions become the property of IBM. If you want a reply, be sure to give your name and address.

Name _____

Occupation _____

Address _____

**Thank you for your cooperation
No postage necessary if mailed in the U.S.A.**



**NO POSTAGE
NECESSARY
IF MAILED
IN THE
UNITED STATES**

BUSINESS REPLY MAIL

FIRST CLASS

PERMIT NO. 40

ARMONK, NEW YORK

POSTAGE WILL BE PAID BY ADDRESSEE

**International Business Machines Corporation
Department 63T
Neighborhood Road
Kingston, New York 12401**



READER'S COMMENT FORM

**3278 Display Station
Models 1, 2, 3, 4, and 5
Maintenance Information**

SY27-2510-4

Please comment on the usefulness and readability of this book, suggest additions and deletions, and list specific errors and omissions (give page numbers). All comments and suggestions become the property of IBM. If you want a reply, be sure to give your name and address.

Name _____

Occupation _____

Address _____

**Thank you for your cooperation
No postage necessary if mailed in the U.S.A.**

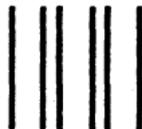

**NO POSTAGE
NECESSARY
IF MAILED
IN THE
UNITED STATES**

BUSINESS REPLY MAIL

FIRST CLASS PERMIT NO. 40 ARMONK, NEW YORK

POSTAGE WILL BE PAID BY ADDRESSEE

**International Business Machines Corporation
Department 63T
Neighborhood Road
Kingston, New York 12401**



SY27-2510-4

*Printed in Great Britain by
Robert MacLehose and Company Limited*



**International Business Machines Corporation
Data Processing Division
1133 Westchester Avenue, White Plains, N.Y. 10604**

**IBM World Trade Americas/Far East Corporation
Town of Mount Pleasant, Route 9, North Tarrytown, N.Y., U.S.A. 10591**

**IBM World Trade Europe/Middle East/Africa Corporation
360 Hamilton Avenue, White Plains, N.Y., U.S.A. 10601**