

GA26-1661-3
File No. 4300-07, S/370-07

Systems

**IBM 3880
Storage Control
Description**

IBM

GA26-1661-3
File No. 4300-07, S/370-07

Systems

**IBM 3880
Storage Control
Description**

IBM
(R)

Fourth Edition, May 1980

This publication replaces and makes the *IBM 3880 Storage Control Description*, Order No. GA26-1661-2 and TNL GN26-0351, obsolete. Changes are indicated by a vertical line to the left of the change.

Periodically, changes or additions may be made to the information in this manual. Before using this publication in connection with the operation of IBM systems, consult your local IBM branch office for the editions that are current and applicable.

It is possible that this material may contain reference to, or information about, IBM products (machines and programs), programming or services that are not announced in your country. Such references or information must not be construed to mean that IBM intends to announce such IBM products, programming, or services in your country.

Copies of this and other IBM publications can be obtained through IBM branch offices.

A form for reader comments is provided at the back of this publication. If the form has been removed, send your comments to the address below.

This manual was prepared by IBM General Products Division, Technical Publishing, Department G26, 555 Bailey Avenue, San Jose, California 95150.

© Copyright International Business Machines Corporation 1979, 1980

Preface

The IBM 3880 Storage Control and its attached disk storage devices provide high-speed, direct-access storage for general purpose data storage and system residence. It attaches to the processing unit through a block multiplexer channel.

For experienced programmers, this manual provides readily accessible reference material related to channel command words, sense bytes, and error recovery.

Less experienced programmers will find sufficient information to create channel programs to best use the standard and special features of the 3880.

This manual is organized by the following topics:

- Introduction – describes the basic units and lists highlights and functions.
- Input/Output Operations – describes operations between the processing unit, channel, and storage control.
- Fixed Block Command Set – describes each command in the fixed block command set and gives examples of channel programs for reading and writing data.
- Count, Key, and Data Command Set – describes each command in the count, key, and data command set and gives examples of channel programs for formatting, reading, and writing.
- Standard and Special Features – describes all the features associated with the 3880 and gives examples of how they are used.
- Sense Bytes and Error Recovery Procedures – describes all sense bytes and error recovery procedures for each type of device that attaches to the 3880.

- Operator Panel – describes the switches and indicators associated with the operation of the 3880.

Programmers should be familiar with the information contained in the *IBM System/370 Principles of Operation*, Order No. GA22-7000, and the *IBM 4300 Processors Principles of Operation*, Order No. GA22-7070.

Additional information about the devices that attach to the 3880 can be found in the following manuals:

Manual	Order Number
<i>Reference Manual for IBM 3330 Series Disk Storage</i>	GA26-1615
<i>Reference Manual for IBM 3340/3344 Disk Storage</i>	GA26-1619
<i>Reference Manual for IBM 3350 Direct Access Storage</i>	GA26-1638
<i>IBM 3370 Direct Access Storage Description</i>	GA26-1657
<i>Introduction to IBM 3375 Direct Access Storage</i>	GA26-1666
<i>Introduction to IBM 3380 Disk Storage</i>	GA26-1662

For definitions of terms used with direct access storage devices, see the *Data Processing Glossary*, Order No. GC20-1699.

Divider tabs are available for the major sections of this manual to provide quick reference to sense bytes, channel commands, and other frequently used information. The order number for the tabs is GX26-1663.

Contents

Introduction	1-1	Device Reserve	3-20
Storage Directors	1-1	Device Release	3-21
Device Configurations	1-1	Unconditional Reserve	3-22
Features	1-3	Diagnostic Control	3-23
Two-Channel Switch Pair	1-3	Diagnostic Sense/Read	3-29
Two-Channel Switch Pair, Additional	1-3	Channel Programs	3-31
Eight-Channel Switch	1-3	Write	3-31
Remote Switch	1-4	Read	3-33
Speed Matching Buffer for 3380	1-4	Count, Key, and Data Command Set	4-1
Block Multiplexer	1-4	No-Operation	4-2
Command Retry	1-4	Recalibrate	4-3
Record Overflow	1-4	Seek	4-4
End of File	1-4	Seek Cylinder	4-6
Multitrack Operation	1-4	Seek Head	4-8
3330, 3333, and 3350 Attachment	1-5	Space Count	4-9
3340 and 3344 Attachment	1-5	Set File Mask	4-11
3370 Attachment	1-5	Set Sector	4-13
3375 Attachment	1-6	Restore	4-14
3380 Attachment	1-6	Transfer-in-Channel	4-15
Input/Output Operations	2-1	Search Home Address Equal	4-16
General Description	2-1	Search Identifier Equal	4-17
Channel Operation	2-2	Search Identifier High	4-18
Channel Address Word	2-2	Search Identifier Equal or High	4-19
Channel Command Word	2-2	Search Key Equal	4-20
Channel Status Word	2-2	Search Key High	4-21
Program Status Word	2-6	Search Key Equal or High	4-22
Status Presentation	2-8	Read Home Address	4-23
Initial Status	2-8	Read Count	4-24
Pending Status	2-9	Read Record Zero	4-25
Contingent Connection	2-10	Read Data	4-26
Addressing	2-10	Read Key and Data	4-27
Channel Commands	2-11	Read Count, Key, and Data	4-28
Control	2-11	Read Multiple Count, Key, and Data	4-29
Write	2-11	Read Initial Program Load	4-31
Read	2-11	Read Sector	4-32
Search	2-12	Sense Input/Output Type	4-33
Sense	2-12	Sense Input/Output	4-34
Test I/O	2-12	Read and Reset Buffered Log	4-35
Diagnostic	2-12	Device Reserve	4-36
Fixed Block Command Set	3-1	Unconditional Reserve	4-37
Transfer-in-Channel	3-2	Device Release	4-38
No-Operation	3-3	Write Home Address	4-39
Define Extent	3-4	Write Record Zero	4-41
Locate	3-7	Erase	4-42
Read	3-11	Write Count, Key, and Data	4-43
Read Initial Program Load	3-13	Write Special Count, Key, and Data	4-44
Write	3-14	Write Data	4-45
Sense Input/Output	3-16	Write Key and Data	4-46
Sense Input/Output Type	3-17	Diagnostic Sense	4-47
Read and Reset Buffered Log	3-18		
Read Device Characteristics	3-19		

Diagnostic Load	4-48	Format 3 – Storage Director Control Check (Hardware Detected)	7-10
Diagnostic Write	4-49	Message Table – Format 3	7-10
Diagnostic Sense/Read	4-50	Format 3 – Storage Director Control Check (Microcode Detected)	7-11
Channel Programs	4-51	Message Table – Format 3	7-11
Track Formatting	4-51	Format 4 – Data Checks Without Displacement Information	7-12
Update Write	4-54	Message Table – Format 4	7-12
Read	4-56	Format 5 – Data Checks With Displacement Information	7-13
Standard and Special Features	5-1	Message Table – Format 5	7-13
Multitrack	5-1	Format 6 – Usage Statistics/Overrun Errors	7-14
Record Overflow	5-2	Message Table – Format 6	7-14
Formatting Overflow Records	5-2	Error Condition Table – 3370	7-15
Processing Overflow Records	5-3	Recovery Action Table – 3370	7-16
End of File	5-4	Sense Bytes – 3330	8-1
Rotational Position Sensing	5-5	Sense Byte 0	8-1
Command Retry	5-8	Sense Byte 1	8-2
Channel Switching	5-8	Sense Byte 2	8-4
Channel Selection Switch	5-8	Sense Byte 3	8-4
Device Status	5-9	Sense Byte 4	8-4
Remote Switching	5-9	Sense Byte 5	8-4
Statistical Usage and/or Error Recording	5-9	Sense Byte 6	8-5
Error Detection and Logging	5-9	Sense Byte 7	8-5
Block Multiplexing	5-9	Format 0 – Program or System Check	8-6
Error Recovery Procedures	6-1	Message Table – Format 0	8-7
Console Error Message	6-1	Format 1 – Device Equipment Check	8-7
Error Correction Function – Fixed Block Devices	6-1	Message Table – Format 1	8-9
Restart CCWs – Fixed Block Devices	6-2	Format 2 – Storage Director Equipment Check	8-10
Error Correction Function – Count, Key, and Data Devices	6-3	Message Table – Format 2	8-10
Restart CCWs – Count, Key, and Data Devices	6-6	Format 3 – Storage Director Control Check (Hardware Detected)	8-11
Command Retry – 3370	6-7	Message Table – Format 3	8-11
Internal Retry	6-7	Format 3 – Storage Director Control Check (Microcode Detected)	8-12
Command Retry – 3330 and 3350	6-8	Message Table – Format 3	8-12
Sense Bytes – 3370	7-1	Format 4 – Data Checks Without Displacement Information	8-13
Sense Byte 0	7-1	Message Table – Format 4	8-13
Sense Byte 1	7-2	Format 5 – Data Checks With Displacement Information	8-14
Sense Byte 2	7-3	Message Table – Format 5	8-14
Sense Byte 3	7-3	Format 6 – Usage Statistics/Overrun Errors	8-15
Sense Byte 4	7-3	Message Table – Format 6	8-15
Sense Byte 5	7-3	Error Condition Table – 3330	8-16
Sense Byte 6	7-3	Recovery Action Table – 3330	8-16
Sense Byte 7	7-4		
Format 0 – Program or System Check	7-4		
Message Table – Format 0	7-4		
Format 1 – Device Equipment Check	7-5		
Message Table – Format 1	7-8		
Format 2 – Storage Director Equipment Check	7-9		
Message Table – Format 2	7-9		

Sense Bytes – 3350	9-1
Sense Byte 0	9-1
Sense Byte 1	9-2
Sense Byte 2	9-4
Sense Byte 3	9-4
Sense Byte 4	9-4
Sense Byte 5	9-4
Sense Byte 6	9-5
Sense Byte 7	9-5
Format 0 – Program or System Check	9-6
Message Table – Format 0	9-6
Format 1 – Device Equipment Check	9-7
Message Table – Format 1	9-10
Format 2 – Storage Director Equipment Check	9-11
Message Table – Format 2	9-11
Format 3 – Storage Director Control Check (Hardware Detected)	9-12
Message Table – Format 3	9-12
Format 3 – Storage Director Control Check (Microcode Detected)	9-13
Message Table – Format 3	9-13
Format 4 – Data Checks Without Displacement Information	9-14
Message Table – Format 4	9-14
Format 5 – Data Checks With Displacement Information	9-15
Message Table – Format 5	9-15
Format 6 – Usage Statistics/Overrun Errors	9-16
Message Table – Format 6	9-16
Error Condition Table – 3330/3350	9-17
Recovery Action Table – 3330/3350	9-18

Sense Bytes – 3340 and 3344	10-1
Sense Byte 0	10-1
Sense Byte 1	10-3
Sense Byte 2	10-4
Sense Byte 3	10-4
Sense Byte 4	10-4
Sense Byte 5	10-5
Sense Byte 6	10-5
Sense Byte 7	10-6
Format 0 – Program or System Check	10-7
Message Table – Format 0	10-7
Format 1 – Device Equipment Check	10-8
Message Table – Format 1	10-11
Format 2 – Storage Director Equipment Check	10-12
Message Table – Format 2	10-12
Format 3 – Storage Director Control Check (Hardware Detected)	10-13
Message Table – Format 3	10-13
Format 3 – Storage Director Control Check (Microcode Detected)	10-14
Message Table – Format 3	10-14
Format 4 – Data Checks Without Displacement Information	10-15
Message Table – Format 4	10-15
Format 5 – Data Checks With Displacement Information	10-16
Message Table – Format 5	10-16
Format 6 – Usage Statistics/Overrun Errors	10-17
Message Table – Format 6	10-17
Error Condition Table – 3340 and 3344	10-18
Recovery Action Table – 3340 and 3344	10-19

Operator Panel	10-24
Subsystem Power	10-24
System Configuration	10-24
Unit Emergency	10-24

Appendix – Device Addressing	A-1
---	-----

Index	X-1
------------------------	-----

Introduction

The IBM 3880 Storage Control Models 1, 2, and 3 provide the logical capabilities to operate and control IBM disk storage devices. Each model of the 3880 provides different device attachment capabilities to satisfy the disk storage requirements for the following IBM systems and processors.

System/Processor	Disk Storage
4341	3330/3333, 3340/3344, 3350, 3370, 3375
4331 Model Group 2	3330/3333, 3340/3344, 3350, 3370, 3375
System/370 Models 145, 145-3, 148, 155-II, and 165-II	3330/3333, 3340/3344, 3350
System/370 Models 158 and 168	3330/3333, 3340/3344, 3350, 3380
3031, 3032, 3033, and 3042 Model 2	3330/3333, 3340/3344, 3350, 3375, 3380

Disk storage attachment to each model of the 3880 is described in the Device Configurations section of this manual. Depending on the type of disk storage attached, the 3880 attaches to the system through standard or high-speed, block-multiplexer channels.

Storage Directors

The 3880 contains two storage directors. Each storage director operates independently so that each one provides the basic functions for storage control. That is, each storage director has its own data path, control path, and address for channel communication (see Figure 1).

Through use of diskettes, each storage director can be initialized to attach the following types of disk storage devices: IBM 3340 and 3344; IBM 3330, 3333, and 3350; IBM 3370; IBM 3375; and IBM 3380.

The five disk storage options listed above are mutually exclusive on a storage director. For example, 3370s cannot be attached to a storage director initialized for 3340s and 3344s, and 3340s and 3344s cannot be attached to a storage director initialized for 3330, 3333, and 3350 disk storage.

When a storage director is initialized to attach 3370 disk storage, it implements the command set required for fixed block channel programs. The 3880 implements the count, key, and data command set for all other disk storage devices.

Device Configurations

The following chart illustrates the various device configurations that may be attached to each model of the 3880.

Model	Storage Director A	Storage Director B
1	Up to 4 strings of 3330/3333/3350s or Up to 4 strings of 3340/3344s or Up to 4 strings of 3370s or Up to 4 strings of 3375s	Up to 4 strings of 3330/3333/3350s or Up to 4 strings of 3340/3344s or Up to 4 strings of 3370s or Up to 4 strings of 3375s
2	Up to 4 strings of 3330/3333/3350s or Up to 4 strings of 3340/3344s or Up to 4 strings of 3370s or Up to 4 strings of 3375s	Up to 2 strings of 3380s
3	Up to 2 strings of 3380s	Up to 2 strings of 3380s

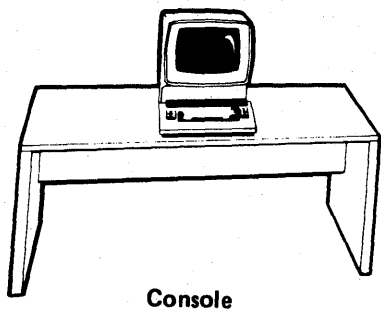

Console

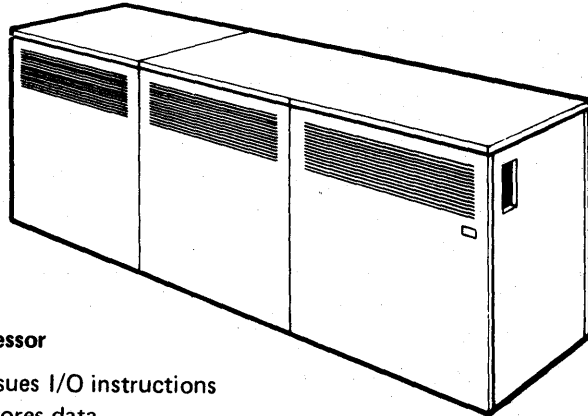

Processor

- Issues I/O instructions
- Stores data
- Stores status
- Stores channel program

Channel

- Fetches channel address words
- Fetches channel commands
- Controls transfer of data between the processor and the 3880

Disk Storage

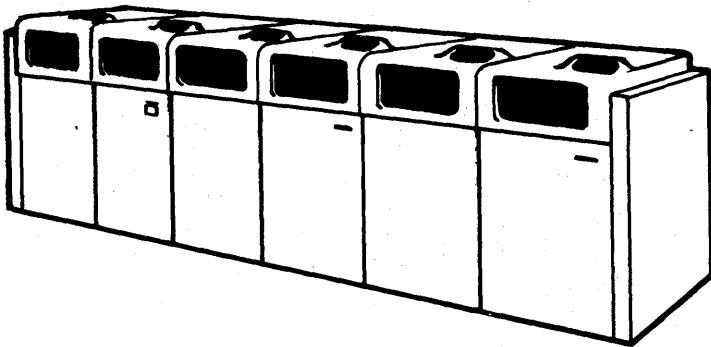

Disk Storage

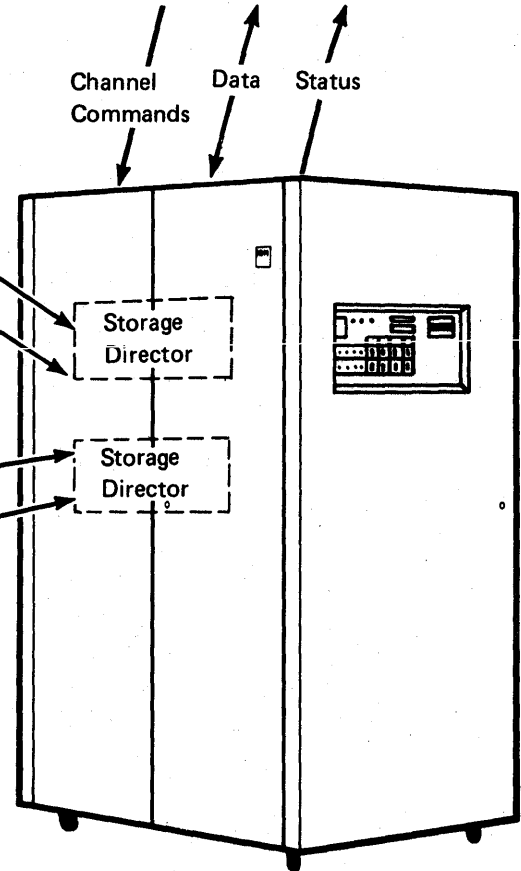
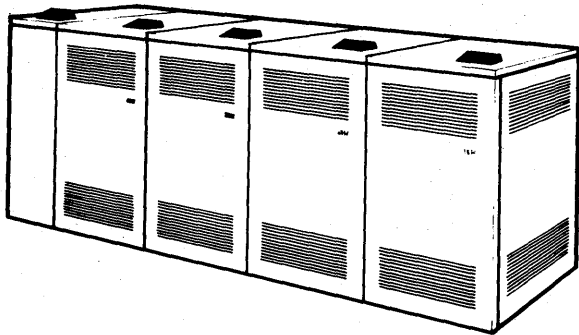

Disk Storage and Controller

- Respond to commands from 3880
- Position access mechanism
- Select head
- Read and write data
- Serialize and deserialize data
- Perform error detection and correction

3880 Storage Control

- Interprets and executes commands from channel
- Controls channel and disk storage interfaces
- Furnishes status to system
- Performs diagnostic evaluation of storage control and attached disk storage

Figure 1. Functional Description

Each storage director must be initialized for the desired device configuration, and is subject to the limitations described in the 3330, 3333, and 3350 Attachment, 3340 and 3344 Attachment, 3370 Attachment, 3375 Attachment, and 3380 Attachment sections of this manual. Storage directors that attach 3380s must either be attached to a 3-megabyte, block-multiplexer channel, which can operate in data streaming mode, or they must have the speed matching buffer feature for 3380s. Attachment of 3375s to the 3031, 3032, 3033, or 3042 Model 2 requires the data streaming feature on the processor.

Storage directors attaching 3350, 3370, or 3375 disk storage must be attached to either a 2- or 3-megabyte, block-multiplexer channel. Storage directors attaching 3330/3333 or 3340/3344 disk storage may be attached to either a 1-, 2-, or 3-megabyte, block-multiplexer channel.

Features

The 3880 is available with or supports the following standard and special features:

Feature	3330/3333/3350	3340/3344	3370	3375	3380
Two-Channel Switch Pair	Yes	Yes	Yes	Yes	Yes
Two-Channel Switch Pair, Additional	Yes	Yes	Yes	Yes	Yes
Eight-Channel Switch	Yes	No	No	No	Yes
Remote Switch	Yes	Yes	Yes	Yes	Yes
Speed Matching Buffer	No	No	No	No	Yes
Block Multiplexer	Yes	Yes	Yes	Yes	Yes
Command Retry	Yes	No	Yes	Yes	Yes
Record Overflow	Yes	Yes	No	No	No
End of File	Yes	Yes	No	Yes	Yes
Multitrack Operation	Yes	Yes	No	Yes	Yes

A brief description of these features follows. For a detailed description see the Standard and Special Features section of this manual. In addition to these features the 3880 also supports the device features listed in the following sections of this manual:

- 3330, 3333, and 3350 Attachment
- 3340 and 3344 Attachment
- 3370 Attachment
- 3375 Attachment
- 3380 Attachment

Two-Channel Switch Pair

The two-channel switch pair feature provides logically separated switching facilities for both storage directors. It allows each storage director to be shared by two channels. The channels may be attached to the same processor or to different processors. Individual drives attached to a storage director may be reserved for the exclusive use of either of the channels.

Two-Channel Switch Pair, Additional

The two-channel switch pair, additional feature is similar to a two-channel switch pair feature except that it enables four channels to share a storage director and its attached drives.

Eight-Channel Switch

The eight-channel switch feature is similar to the other channel switch features except that it enables eight channels to share both storage directors and their attached drives. This feature is available with 3330, 3333, and 3350 disk storage, and with 3380 disk storage.

Remote Switch

The remote switch features remove the Enable/Disable switches from the 3880 operator panel and relocate them to a remote location. This allows an operator to reconfigure the system from a central point.

Speed Matching Buffer for 3380

The speed matching buffer feature allows 3380s to attach to block-multiplexer channels with a data rate less than 3 megabytes per second. The speed matching buffer can be installed in one storage director in a 3880 Model 2 or in either one or both storage directors in a 3880 Model 3. This feature is required to attach 3380s to System/370 Models 158 and 168 and to block multiplexer channels without data streaming on the 3031, 3032, 3033, and 3042.

If, through use of a channel switch feature, a storage director is attached to a 3-megabyte channel and a slower channel, the speed matching buffer supports the 3-megabyte channel at a 3-megabyte data rate and the slower channel at a 1.5-megabyte data rate.

Block Multiplexer

The block multiplexer feature allows a storage director to disconnect from the channel during mechanical delays caused by commands that require repositioning of the access mechanism or excessive rotational delay.

Command Retry

Command retry is a channel/storage director procedure that allows a command in a channel program to be automatically retried. The retry does not cause an I/O interrupt and programmed error recovery procedures are not required.

Command retry is a standard feature on 3330, 3333, 3350, 3370, 3375, and 3380 devices; it is not used on 3340s and 3344s.

Record Overflow

The record overflow feature allows a storage director to process logical records that exceed the capacity of a track. When using overflow records, the factor limiting the size of the record is the cylinder boundary.

Record overflow is a standard feature on 3330, 3333, 3340, 3344, and 3350 devices; it is not used on 3370s, 3375s, or 3380s.

End of File

An end-of-file record defines the end of a logical group of records. It is written by executing a Write Count, Key, and Data command with a data length of zero. Execution of the command by the storage director instructs a drive to write a data area consisting of one byte of zeros.

End of file is a standard feature for all devices except the 3370; it is not required on 3370s because of the fixed block format used with these devices.

Multitrack Operation

On all search and most read commands, a storage director can automatically select the next sequentially numbered head on a drive. This eliminates the need for Seek Head commands in a chain of read or search commands.

The multitrack feature is standard for all devices except 3370s; it is not required on 3370s because of the fixed block format used with these devices.

3330, 3333, and 3350 Attachment

When initialized for 3330, 3333, and 3350 operations, each storage director can attach up to four strings of 3330/3333 and/or 3350 disk storage. The first device on a 3330/3333 string must be a 3333 Model 1 or 11. Each 3333 may attach up to three 3330 Models 1, 2, or 11 in any combination.

The first device on a 3350 string must be a 3350 Model A2 or A2F. Each 3350 Model A2 or A2F may attach up to three 3350 Model B2s or B2Fs or up to two 3350 Model B2s or B2Fs and one 3350 Model C2 or C2F. The 3350s must operate in native mode.

Strings of 3330/3333s and 3350s may be intermixed on the same storage director.

The 3880 supports the following 3330, 3333, and 3350 features:

- Rotational position sensing
- String switch option
- Remote switch
- 3350 fixed head option
- 3350 alternate controller feature

These features are described in the *Reference Manual for IBM 3350 Direct Access Storage*, Order No. GA26-1638, and in the *Reference Manual for IBM 3330 Series Disk Storage*, Order No. GA26-1615.

3340 and 3344 Attachment

Each storage director, when initialized for 3340 and 3344 operation, can attach up to four strings of 3340s and 3344s. With the following limitations, the 3340s and 3344s may be intermixed on the same strings.

- On all strings, the first unit must be a 3340 Model A2.
- On strings 0 and 2, one, two or three 3340 Model B2s or 3344 Model B2s may attach in any order or combination. A 3340 Model B1 may replace one B2 at the end of the string.
- On string 1, one, two, or three 3340 Model B2s may be attached. A 3340 Model B1 may replace one B2 at the end of the string.
- On string 3, one 3340 Model B1 or B2 may be attached.

A maximum of 28 physical drives are allowed with a maximum of 64 logical device addresses.

The 3880 supports the following device features:

- String switch option
- Remote switch
- Rotational position sensing
- Fixed head option

These features are described in the *Reference Manual for IBM 3340/3344 Disk Storage*, Order No. GA26-1619.

3370 Attachment

When initialized for 3370 operation, each storage director can attach up to four strings (16 physical spindles or 32 logical device addresses) of 3370 Disk Storage devices. The first unit on a string must be a 3370 Model A1; up to three 3370 Model B1s may be attached to the Model A1.

The 3880 supports the 3370 string switch feature. This feature is described in *IBM 3370 Direct Access Storage Description*, Order No. GA26-1657.

3375 Attachment

When initialized for 3375 operation, a storage director can attach up to four strings (32 logical device addresses) of 3375 disk storage. The first unit on a string must be a model A. Up to three additional model Bs may be attached to the first unit.

The 3880 supports the string switch feature that is available with the 3375. This feature is described in the *Introduction to IBM 3375 Direct Access Storage*, Order No. GA26-1666.

3380 Attachment

When initialized for 3380 operation, each storage director can attach up to two strings (32 logical device addresses) of 3380 disk storage. The first unit on a string must be a model A. Up to three additional model Bs may be attached to the first unit.

The 3880 supports the dynamic path selection function available with some models of 3380. Models with the dynamic path selection function may not be attached to a storage director with models not having the dynamic path selection function.

The 3380 is described in greater detail in the *Introduction to IBM 3380 Disk Storage*, Order No. GA26-1662.

Input/Output Operations

General Description

Input/output (I/O) operations, initiated by I/O instructions in the system control program, are controlled by commands fetched from main storage by the channel. Arithmetic and logical operations are performed while the processing unit is in the problem state; for I/O operations, the processing unit must be in the supervisor state.

The processing unit is changed from problem to supervisor state when a supervisor call instruction is executed or when an I/O interrupt occurs. The status of the system at the time of the change is stored in the program status word (PSW). See the Program Status Word section of this manual.

In the supervisor state, the processing unit can execute the following I/O instructions:

- Start I/O – Initiates an I/O operation if the addressed channel, storage director, and disk drive are available.
- Start I/O Fast Release – Initiates an I/O operation if the addressed channel is available. The storage director and disk storage are assumed to be available. If not, an I/O interrupt occurs to indicate an unavailable condition.
- Halt I/O – Terminates the operation in progress at the channel and the storage director is disconnected from the channel.
- Halt Device – Terminates the operation in progress at the storage director without interfering with other I/O operations at the channel. This instruction should be used instead of Halt I/O to terminate an operation on a device attached to IBM block multiplexer channels.
- Test I/O – Sets the condition code in the program status word to indicate the status of the addressed channel, subchannel, storage director, and disk storage.
- Clear I/O – Discontinues the operation with the addressed device and stores the status of the discontinued operation in the channel status word (CSW).

After the specified instruction has been executed, the processing unit can return to the problem state and continue the interrupted program by reloading the program status word originally stored when the program entered the supervisor state.

The format and function for I/O instructions are shown in Figure 2.

Channel Operation

After successful execution of an I/O instruction, the channel independently selects and governs the storage director and drive addressed by the instruction. Reserved main storage locations contain information and instructions that enable the channel to perform those functions necessary to complete the operation.

Channel Address Word

Issuing a Start I/O or Start I/O Fast Release instruction causes the channel to fetch the channel address word from main storage location 72. Bits 0 through 3 of the channel address word (CAW) form the subchannel key for all commands associated with the I/O instruction. The subchannel key establishes the right of access (that is, whether data can be stored or fetched) to the particular main storage locations.

The command address in bits 8 through 31 designates the address of the first channel command word. The three low-order bits of the command address must be zero to specify the channel command word on doubleword boundaries.

Fetching of channel address words is a channel hardware function. The information must be set up in main storage location 72 before the processor issues the I/O instruction.

The format and function of the channel address word are shown in Figure 3.

Channel Command Word

The channel fetches the first channel command word (CCW) from the address specified in the channel address word. The CCW specifies the operation to be performed, the main storage locations to be used, and the action to be taken when the operation is completed.

The channel, if available when it receives the channel command word, attempts to select the device specified in the I/O instruction by sending the address to all attached control units. If the addressed device is attached to the channel and has power on, the command code portion of the channel command word is sent to the storage director, which responds with an initial status byte to the channel.

At this point, the Start I/O instruction is finished, releasing the processing unit to perform the next instruction. The results of the attempt to initiate execution of the command are indicated by the condition code in the program status word. If the I/O operation was not started, new status information containing the reason for this condition is usually set in the channel status word.

The format for the channel command word is shown in Figure 4.

Channel Status Word

The channel status word (CSW), stored at main storage location 64, informs the program of I/O device status or the conditions under which an I/O operation was terminated. The CSW is formed or changed during I/O interruptions and instruction execution. Status stored in the CSW remains unchanged until a subsequent interrupt occurs or a new I/O instruction is processed.

The format for the channel status word is shown in Figure 5.

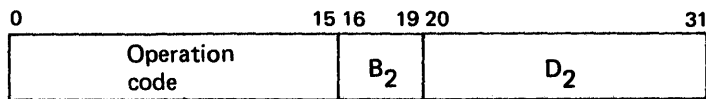

Bit Position	Field Designation	Function
0–15	Operation code	Bits 0 through 15 designate the operation to be performed.
16–31	Basic address register location (B ₂) and displacement (D ₂)	The sum obtained by adding the contents of the register at B ₂ and the contents of the D ₂ field identify the channel and device addressed by the instruction. The address has the following format:

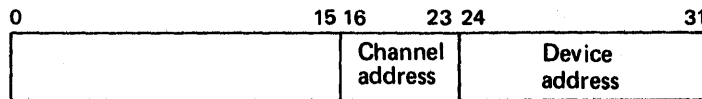
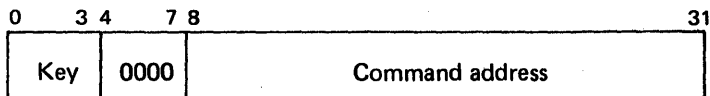
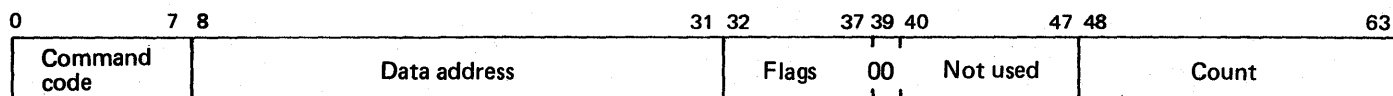

Figure 2. I/O Instruction Format



Bit Position	Field Designation	Function
0–3	Subchannel key	Bits 0 through 3 form the storage protection key for all commands associated with Start I/O and Start I/O Fast Release instructions. This key must match the storage key.
4–7	Not used	Bits 4 through 7 are always zero.
8–31	Command address	Bits 8 through 31 designate the location of the first CCW in main storage.

Figure 3. Channel Address Word



Bit Position	Field Designation	Function
0–7	Command code	Bits 0 through 7 specify the operation to be performed. The four low-order bits of the command code identify the operation to the channel. The channel distinguishes the operations: write, control, read, sense, or transfer-in-channel. Commands that initiate I/O operations cause all eight bits to be transferred to the storage director.
8–31	Data address	Bits 8 through 31 specify the address of the area associated with data transfer operations.
32	Chain data (CD)	When set to 1, bit 32 specifies data chaining. Before setting this bit to 1, make sure the data rate of the I/O device permits chaining by the particular system model. <i>Note: Data chaining capabilities are dependent on several variable factors including system type, I/O configuration, channel loading and so on. Because of these dependencies, read or write data chaining within record areas may cause unpredictable results such as channel data checks, overruns or chaining errors. If these conditions are found or suspected, consult your IBM representative.</i>
33	Chain command (CC) flag	When set to 1, and when the CD flag is 0, bit 33 specifies command chaining. It causes the operation specified by the command code in the next CCW to be initiated after completion of the current operation.
34	Suppress length indicator (SLI)	When set to 1, bit 34 causes an incorrect length condition to be suppressed (except when the CCW count is not exhausted, channel end is present, and data chaining is indicated). This bit should be set to 1 for Restore, Recalibrate, No-Op, and some Space Count commands.
35	Skip flag	When set to 1, bit 35 specifies suppression of a transfer of information to storage during a read or sense operation. Checking takes place as though the information had been placed in storage. When bit 35 is 0, normal transfer of data takes place.
36	Program controlled interrupt	When set to 1, bit 36 causes the channel to generate an interrupt upon fetching the CCW. When bit 36 is 0, normal operation takes place.
37	Indirect data address	When set to 1, bit 37 specifies indirect data addressing.
38–39		Bit positions 38 and 39 of every CCW, other than one that specifies a Transfer-in-Channel command, must contain zeros. Violation of this restriction generates a program check condition.
40–47	Not used	Bits 40 through 47 are not used.
48–63	Count	Bits 48 through 63 specify the number of 8-bit byte locations in the storage area designated by the data address.

Figure 4. Channel Command Word

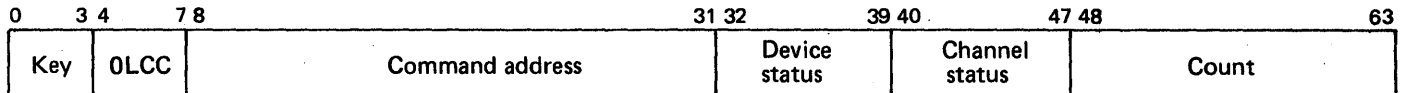

Bit Position	Field Designation	Function
0–3	Subchannel key	Bits 0 through 3 are the storage protection key used in the chain of operations.
4	Not used	Bit 4 is always zero.
5	Logout pending (L)	When set to 1, bit 5 indicates that an I/O instruction cannot be executed until a pending logout condition is cleared.
6–7	Deferred condition code (CC)	Bits 6 and 7 indicate whether conditions have been encountered, subsequent to the setting of CC=0 for the Start I/O Fast Release instruction, that would have caused a different setting for a Start I/O instruction.
8–31	Command address	Bits 8 through 31 usually contain an address eight positions higher than the address of the last CCW used.
32	Attention	Bit 32 is not used.
33	Status modifier	<p>Bit 33 is set whenever a Search High, Search Equal, or a Search High or Equal command has been executed and the condition was satisfied (CKD command set only).</p> <p>The status modifier is also set whenever the storage director is busy. This bit, in conjunction with the busy bit, signifies that the storage director is busy.</p> <p>It is also set with channel end and unit check to initiate command retry.</p>
34	Control unit end	Bit 34 is set if a storage director busy status has been generated previously and the busy condition has been terminated.
35	Busy	<p>Bit 35 indicates that the selected device is busy.</p> <p>It also is set in response to any command (except Test I/O) if there is outstanding status for the device.</p>
36	Channel end	Bit 36 is set at the end of each channel command or command chain.
37	Device end	When set without other status bits, bit 37 indicates that the device is available. It is also set with channel end after successful completion of all commands not requiring access motion or media positioning.
38	Unit check	<p>Bit 38 is set whenever an unusual or error condition is detected. A sense I/O command may then be used to identify the condition.</p> <p>It also is set with status modifier and channel end to indicate command retry.</p>

Figure 5. Channel Status Word (Part 1 of 2)

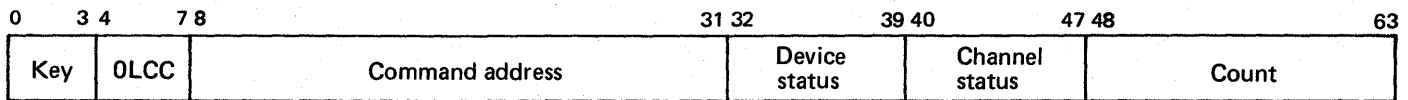

Bit Position	Field Designation	Function																		
39	Unit exception	<p>For fixed block, bit 39 is set with channel end and device end to indicate that the trace/dump buffer is not valid during execution of a Diagnostic Sense/Read command.</p> <p>For CKD, it indicates an end of file has been detected during a Read R0, Read IPL, Read CKD, Read Key and Data, Read Data, Write Key and Data, or a Write Data command. It results from a data length of zero being detected in the count area of a record. When this condition is detected, no data is transferred from the data area. If the key length is not zero, the key area is transferred.</p>																		
40–47	Channel status	<p>Bits 40 through 47 indicate channel conditions as follows:</p> <table border="0" style="margin-left: 20px;"> <thead> <tr> <th style="text-align: left;">Bit</th> <th style="text-align: left;">Designation</th> </tr> </thead> <tbody> <tr><td>40</td><td>Program-controlled interruption</td></tr> <tr><td>41</td><td>Incorrect length</td></tr> <tr><td>42</td><td>Program check</td></tr> <tr><td>43</td><td>Protection check</td></tr> <tr><td>44</td><td>Channel data check</td></tr> <tr><td>45</td><td>Channel control check</td></tr> <tr><td>46</td><td>Interface control check</td></tr> <tr><td>47</td><td>Chaining check</td></tr> </tbody> </table>	Bit	Designation	40	Program-controlled interruption	41	Incorrect length	42	Program check	43	Protection check	44	Channel data check	45	Channel control check	46	Interface control check	47	Chaining check
Bit	Designation																			
40	Program-controlled interruption																			
41	Incorrect length																			
42	Program check																			
43	Protection check																			
44	Channel data check																			
45	Channel control check																			
46	Interface control check																			
47	Chaining check																			
48–63	Count	Bits 48 through 63 contain the residual count from the last CCW used.																		

Figure 5. Channel Status Word (Part 2 of 2)

Program Status Word

Bit position 12 of the program status word (PSW) determines whether the processor is operating in basic control (BC) mode or in extended control (EC) mode.

The two modes determine allocation of bit positions within the PSW, the use of permanently assigned locations in main storage for storing the interruption code, instruction length code, and the controlling of I/O interruptions for channels 0 through 5. The BC mode of operation (specified when bit 12 is 0) is provided on all processors. The EC mode (specified when bit 12 is 1) is available only with the extended control feature. Bit assignment for both modes is shown in Figure 6.

When an I/O interrupt occurs, the current program status word is stored, and a new program status word is loaded. By storing the current PSW during an interruption, processor status is preserved for subsequent inspection by the program. Loading a new PSW causes the state of the processor to be initialized or changed to branch to a new instruction sequence. If, at the conclusion of an interrupt routine, an instruction is executed that restores the old PSW as the new PSW, the system is restored to the state existing prior to the interruption, and the interrupted routine continues.

A detailed description of the program status word can be found in *IBM System/370 Principles of Operation*, Order No. GA22-7000 and *IBM 4300 Processors Principles of Operation*, Order No. GA22-7070.

Program Status Word Format in BC Mode

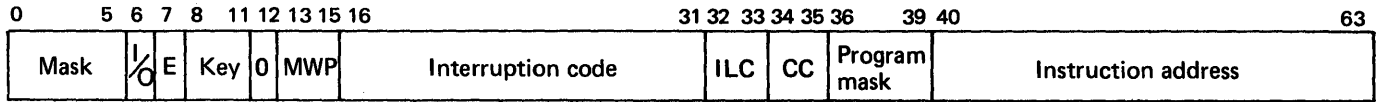

Bit Position	Field Designation
0	Channel 0 mask
1	Channel 1 mask
2	Channel 2 mask
3	Channel 3 mask
4	Channel 4 mask
5	Channel 5 mask
6	I/O mask
7	External mask (E)
8–11	Access key
12	0 = BC mode
13	Machine check mask (M)
14	Wait state (W)
15	Problem state (P)
16–31	Interruption code
32–33	Instruction length code (ILC)
34–35	Condition code (CC)
36	Fixed-point overflow mask
37	Decimal overflow mask
38	Exponent underflow mask
39	Significance mask
40–63	Instruction address

}	Program mask
---	--------------

Program Status Word Format in EC Mode

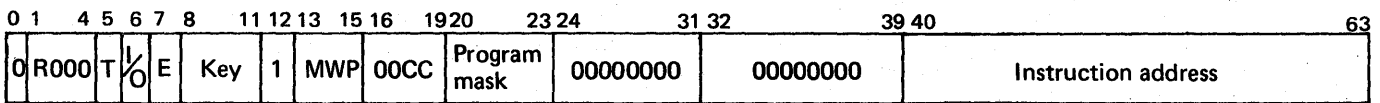

Bit Position	Field Designation
0	Always zero
1	Program event recording mask (R)
2	Always zero
3	Always zero
4	Always zero
5	Translation mode (T)
6	I/O mask
7	External mask (E)
8–11	Access key
12	1 = EC mode
13	Machine check mask (M)
14	Wait state (W)
15	Problem state (P)
16–17	Always zero
18–19	Condition code (CC)
20	Fixed-point overflow mask
21	Decimal overflow mask
22	Exponent underflow mask
23	Significance mask
24–39	Always zero
40–63	Instruction address

}	Program mask
---	--------------

Figure 6. Program Status Word

Status Presentation

Initial Status

The initial status byte is zero for Test I/O instructions and all non-immediate commands unless one or more of the following conditions exists:

- Control unit busy is indicated for one of the following reasons:
 1. A write operation is still in progress after chaining has been terminated.
 2. The storage director is disconnected during command chaining when a storage control error recovery procedure is in progress.
 3. The storage director is performing a format defective block, check data, or format ID operation. (See the Channel Commands section for a description of the Locate, Write, or Diagnostic Control commands.)
 4. The storage director is executing a diagnostic test.
 5. A status condition is pending in the storage director for other than the addressed device. (See the Pending Status section of this manual.)
 6. A system reset is in progress.
 7. The storage director is maintaining a contingent connection to some device other than the addressed device. (See the Contingent Connection section of this manual.)
 8. A storage director initiated connection is preferred over a channel initiated connection because presentation of consecutive device busy or zero status to the channel exceeds the number of devices that can be attached to the storage director.
 9. The channel switch is busy.
- A status condition is pending in the storage director. (See the Pending Status section of this manual.) The pending status is presented as initial status and the busy bit is included in the status byte unless a Test I/O instruction was being executed. The busy bit indicates that the device is busy because of the outstanding status. The pending status is then cleared unless it is stacked by the channel. After the status is cleared, the device must be readdressed to determine whether it is available.
- The device is busy to the channel interface. In this case, the busy bit appears alone in the initial status byte. The device is busy to the interface if channel end occurred without device end for the device, and device end has not been generated, or if the device is reserved by another interface.
- A status condition is pending in the device. (See the Pending Status section of this manual.) The pending status is presented as initial status and the busy bit is included in the status byte unless a Test I/O instruction was being executed. The pending status is then cleared unless it is stacked by the channel.
- A unit check condition exists at the storage director or device. In this case, unit check is presented as initial status unless the command was one of the sense commands. A zero initial status byte is presented for the sense commands.
- Initial status indicates command retry.
- Invalid parity is sensed in the command code.

Immediate commands (commands not requiring data transfer) present channel end and device end in initial status.

Pending Status

A pending status condition can exist for either the storage director or a device.

Status is pending for the storage director if:

- A Halt I/O or Halt Device instruction was signaled after a command was issued but before channel end status was accepted. The ending status for the operation is pending after the operation is complete.
- A Halt I/O or Halt Device instruction was signaled during a Test I/O instruction before the status was accepted by the channel. The status for the addressed device remains pending in the storage director.
- Busy, channel end, or unit check status was stacked by the channel.
- Zero status in response to a Test I/O instruction was stacked by the channel.
- Control unit busy status was presented to the channel. (Control unit end is pending.)
- Device end status from a Locate or Diagnostic Control command is stacked.

Note: *If device end status for a pack change interrupt is stacked in a multichannel environment, the status is pending in the storage director, but the storage director does not appear busy for all other devices.*

Status pending for the storage director (except for control unit end) causes the storage director to appear busy for all devices except the device for which the status condition exists. Unless it is busy, the storage director will request service to clear the pending status. Status is cleared when presented to, and accepted by, the channel.

Status is pending for a device if:

- Channel end was presented alone.
- Busy status was presented.
- The device has gone from a not ready status to a ready status.
- Device end status from a Seek or Set Sector command is stacked.

Status pending for a device causes the storage director to request service when both the storage director and device are not busy. The status is cleared when presented to, and accepted by, the channel.

Device end status is the only condition that can be pending in a device.

Priority of Pending Status Conditions

When presented via polling, the priority of pending status conditions is:

- Status pending in the storage control (except control unit end)
- Unsuppressible status
- Suppressible device end status
- Control unit end status

Note: *During a contingent connection, control unit end has first priority.*

Address Associated with Pending Status

All status conditions (except control unit end) are associated with a specific device address. When there is no contingent connection, control unit end may be cleared by addressing any of the devices attached to the storage director. However, during a contingent connection, control unit end is associated with the specific address for which the contingent connection is being maintained.

When presented via polling, the address associated with control unit end status is always that of a non-busy device within the range of addresses recognized by that storage director.

Suppressible Status

All status conditions are suppressible except (1) device end status associated with channel end for which chaining has been indicated and (2) the device end status associated with unchained Locate or Diagnostic Control commands.

Contingent Connection

A contingent connection is established in the storage director after the channel accepts a status byte containing unit check. It lasts until a command other than Test I/O or No-Operation receives an initial status byte of zero for the storage director and device address that generated the unit check, or a selective or system reset occurs.

During the contingent connection state, the storage director is busy to all addresses other than the address for which the contingent connection state was established.

Addressing

Each storage director and device is assigned an I/O address at the time of installation. This address (8 bits) is used by the program to select a particular device. The address is specified in bits 24 through 31 of the I/O instruction and has the following format:

Bit	Function
0-1	Storage director address
2-4	Storage director and controller address or controller address
5-7	Logical device address

Condition code 3 (not operational) is set in the PSW if an attempt is made to address a storage director, controller, or string that is non-existent, powered off, or disabled by the string switch feature.

If an addressed drive in a properly selected string or controller is non-existent or powered off, unit check is presented in the initial status.

See the Appendix for additional information regarding device addressing.

Channel Commands

The 3880 supports two different channel command sets: one for devices using a count, key, and data (CKD) format, and one for devices using a fixed block format. In most cases the command codes for each command set are different and cannot be used with the other command set.

There are six basic types of commands: control, write, read, search, sense, and diagnostic. The following is a brief description of the basic types of commands. Individual commands for each command set are described in detail in the Fixed Block Command Set and Count, Key, and Data Command Set sections of this manual.

Control

Control commands do not involve a transfer of data records between the storage director and main storage. However, in many cases control information is transferred from main storage to the storage director. This information may include an order code specifying some further action to be taken by the storage director or device, or it may contain parameters defining the types of operations that are allowed or data areas which may be accessed.

The data address field of the channel command word designates the location containing the required additional information.

Write

Write commands transfer data from main storage to disk storage. Data is fetched from main storage in an ascending order of addresses, starting with the address specified in the data address field of the channel command word.

Read

Read commands transfer data from disk storage to main storage. Data is placed in main storage in an ascending order of addresses, starting with the address specified in the data address field of the channel command word.

When using the count, key, and data command set, some read commands can operate in either single-track or multitrack mode. These commands are identified in the individual command descriptions in the Count, Key, and Data Command Set section of this manual.

Search

The search commands are part of the count, key, and data command set. During execution of search commands, the channel operates in write mode while the disk storage operates in read mode. The storage director compares the data coming from the drive against the data from main storage. When the search requirement has been satisfied (for example, compared equal, high, and so on), the storage director returns a status modifier bit with channel end and device end. This causes the channel to skip the next CCW in the chain and fetch the next command from a storage location 16 positions higher than the current CCW. This is normally done by chaining a Transfer-in-Channel (TIC) command to the search command. The following is an example of this procedure:

```
Search Key Equal
TIC*-8
Read Data
```

As long as the search is unsuccessful, the TIC command following the search command causes the search to be repeated. When the search is successful, the status modifier causes the TIC command to be skipped and the Read Data command to be executed.

Sense

The Sense I/O command transfers 24 bytes of information from the storage director to the channel. The Sense I/O Type command transfers seven bytes of information that define the DASD configuration. These 24 bytes provide information concerning unusual conditions detected in the last operation and the current status of the storage director and device.

Other sense type commands perform other functions (such as reserving a device) in addition to transferring the sense information.

Test I/O

The Test I/O command is not the result of the channel executing a CCW and it is not written into the channel program by the programmer.

The Test I/O command is automatically generated by the channel when the channel requires status information, or is the result of processing a Test I/O instruction. In either case, it appears to the storage director as a command byte of all zeros and is treated as an immediate command. Test I/O requests the storage director to send all outstanding status information to the channel. Test I/O normally presents an all-zero status byte. Stacked or pending status (if any) is presented in initial status.

Diagnostic

Diagnostic commands are used to transfer diagnostic information between the channel and storage director. The commands are used for maintenance purposes only. Any use other than that provided by IBM diagnostic programs may yield unpredictable results.

Fixed Block Command Set

Figure 7 is a summary of the fixed block command set used for 3370 operation. This section of the manual also contains a detailed description of each command.

Command	Command Code	
	Hexa- decimal	Binary
Control		
Transfer-in-Channel (TIC)	'X8' *	XXXX 1000
No-Operation (No-Op)	'03'	0000 0011
Define Extent	'63'	0110 0011
Locate	'43'	0100 0011
Read		
Read	'42'	0100 0010
Read Initial Program Load (IPL)	'02'	0000 0010
Write		
Write	'41'	0100 0001
Sense		
Sense Input/Output (I/O)	'04'	0000 0100
Sense Input/Output (I/O) Type	'E4'	1110 0100
Read and Reset Buffered Log	'A4'	1010 0100
Read Device Characteristics	'64'	0110 0100
Device Reserve	'B4'	1011 0100
Device Release	'94'	1001 0100
Unconditional Reserve	'14'	0001 0100
Diagnostic		
Diagnostic Control	'F3'	1111 0011
Diagnostic Sense/Read	'C4'	1100 0100
* The X is not significant. The data addresses should not exceed storage capacity.		

Figure 7. Summary of the Fixed Block Command Set.

Transfer-in-Channel

0	7 8	31 32	37 39 40	47 48	63
Command Code	Data Address	Flags	Not Used	Count (Decimal)	
XXXX 1000 'X8'	Specifies the main storage location of the next CCW.	Ignored	00		Ignored

Function

The Transfer-in-Channel (TIC) command provides chaining capabilities for CCWs not located in adjacent main storage locations.

Chaining Requirements

The TIC command cannot be the first CCW designated by the channel address word. One TIC command cannot transfer directly to another TIC command.

Status

No unit status is presented. The channel status portion of the CSW is stored if either of the special requirements is violated, or if the data address portion of the CCW does not specify an address on a doubleword boundary.

Description

The TIC command does not initiate any I/O operation at the channel, and the storage director and device are not signaled when the command is executed. The purpose of the TIC command is to provide chaining capabilities for CCWs not located in adjacent doubleword locations in main storage. To address a CCW on integral boundaries for doublewords, the TIC command must contain zeros in bits 29 through 31. The contents of bit positions 0 through 3 and 32 through 63 are ignored.

No-Operation

0	7	8	31	32	37	39	40	47	48	63
Command Code	Data Address				Flags		Not Used		Count (Decimal)	
0000 0011 '03'	Not checked for validity; should not exceed addressing capacity				Used at the discretion of programmer		00		Must be nonzero to avoid program check	

Function

The No-Operation (No-Op) command is used to maintain channel connection during I/O operations.

Chaining Requirements

None.

Status

Channel end and device end are presented in initial status.

Description

The No-Op command is processed as an immediate command. It causes no action at the addressed device. Channel end is signaled immediately upon receipt of the command code.

Define Extent

0	7 8	31 32	37 39 40	47 48	63
Command Code	Data Address	Flags	Not Used	Count (Decimal)	
0110 0011 '63'	Specifies the main storage location of the first byte of parameters	Used at the discretion of programmer	00		16

Function

The Define Extent command transfers 16 bytes of parameters from the channel to the storage director. The parameters define the size and location of a data extent.

Chaining Requirements

The Define Extent command must not be preceded by another Define Extent command in the same chain.

Status

Initial status is normally zero. Channel end and device end are presented after the parameters have been transferred and checked for validity. Invalid parameters cause the command to be terminated with channel end, device end, and unit check status.

Description

The data extent area, defined by the parameters transferred to the storage director, establishes limits on the device within which subsequent chained commands are permitted to operate. The parameter list also contains an inhibit mask to determine which types of commands are permitted in the chain.

The format of the parameters transferred is:

Byte	Description
0	Mask byte
1	Must be zero
2 and 3	Block size
4 through 7	Offset to first block of extent
8 through 11	Relative displacement, in the data set, to the first block of the extent
12 through 15	Relative displacement, in the data set, to the last block of the extent

The Define Extent command parameters are retained in the storage director until the end* of the command chain.

Define Extent

0	7 8	31 32	37 39 40	47 48	63
Command Code	Data Address	Flags	Not Used	Count (Decimal)	
0110 0011 '63'	Specifies the main storage location of the first byte of parameters	Used at the discretion of programmer	00		16

Description (Continued)

Byte 0

This byte is the mask byte. It is used to inhibit or control certain operations in subsequent commands in the chain. The function of the bits is:

Bits	Function
0 and 1	
00	Inhibits format write operations
01	Inhibits all write operations
10	Must not be used
11	Permits all write operations
2 and 3	Must be 00 or parameters are invalid
4	
0	Data area
1	CE area. Used for maintenance purposes only
5	
0	Inhibit diagnostic commands
1	Permit diagnostic commands
6 and 7	Must be 00 or parameters are invalid

Byte 1

This byte is not used, but it must be set to zero or the parameters are invalid.

Bytes 2 and 3

These bytes define the blocksize and should be set to a value of 512. (A value of zero in these bytes is interpreted as a default value of 512.)

Define Extent

0	7 8	31 32	37 39 40	47 48	63
Command Code	Data Address	Flags	Not Used	Count (Decimal)	
0110 0011 '63'	Specifies the main storage location of the first byte of parameters	Used at the discretion of programmer	00		16

Description (Continued)

Bytes 4 through 7

These bytes define the offset, in blocks, from the beginning of the data set to the first block of the extent.

Bytes 8 through 11

These bytes define the relative displacement, in blocks, from the beginning of the data set to the first block of the extent.

Bytes 12 through 15

These bytes define the relative displacement, in blocks, from the beginning of the data set to the last block of the extent.

Note: The storage director uses the offset parameters to determine if the extent of the data set is within the limits of the addressed device. If the limit is exceeded, the Define Extent command parameters are invalid and the command is terminated with channel end, device end, and unit check status.

The following example illustrates the use of bytes 4 through 15 in the Define Extent command. This is a data set consisting of three extents recorded on two logical devices. For example, if bytes 4 through 15 = '00 00 02 08 00 00 00 64 00 00 00 95.'

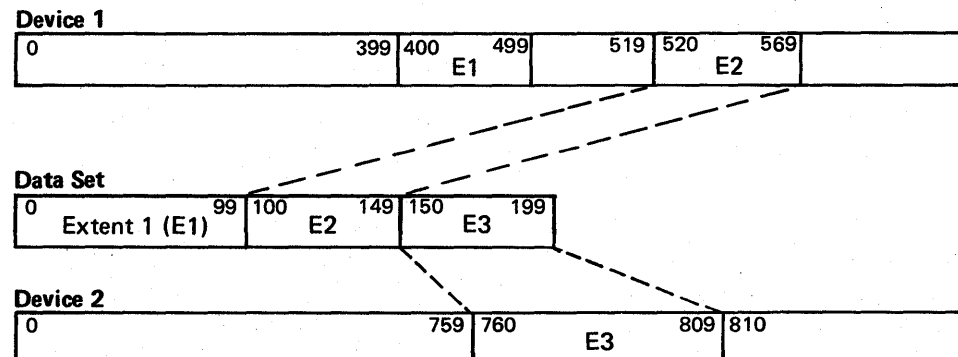

In the example, the Define Extent command is used to specify the second extent area of the data set. The limits of the extent are defined by the two displacements relative to the beginning of the data set (blocks 100₁₀ and 149₁₀). The location of the extent on the device is specified by an offset from the beginning of the device (block 520₁₀).

A subsequent Locate command would specify a particular block of data by using a displacement from the beginning of the data set. A valid parameter in the Locate command for this example would be in the range from block 100₁₀ to block 149₁₀.

Locate

0	7 8	31 32	37 39 40	47 48	63
Command Code	Data Address	Flags	Not Used	Count (Decimal)	
0100 0011 '43'	Specifies the main storage location of the first byte of parameters	Used at the discretion of programmer	00		8

Function

The Locate command transfers eight bytes of parameters from the channel to the storage director. The parameters specify the location and amount of the data to be processed.

Chaining Requirements

The Locate command must be preceded by a Read IPL or Define Extent command in the same chain or the command is rejected with channel end, device end, and unit check status.

Status

Initial status is normally zero. Channel end is presented after the parameters have been transferred and checked for validity. See the following description for conditions causing command termination and status associated with the termination.

Description

The parameters transferred by this command have the following format:

Byte	Description
0	Operation byte
1	Auxiliary byte
2 and 3	Number of blocks to be transferred
4 through 7	Relative displacement of the first data block in the data set

Byte 0

Byte 0 is the operation byte. It specifies the type of record orientation that is required, and the operation to be performed when the desired track position is reached. Byte 0 consists of two functional parts; bits 0 through 3 are modifier bits, and bits 4 through 7 define the operation code.

Modifier Bits (0 through 3). The modifier bits are not used for 3880/3370 operations. Bits 0, 1, and 2 are reserved and must be set to zero; otherwise the parameters are invalid and the command will terminate with device end and unit check status. Bit 3 is not used.

Locate

0	7 8	31 32	37 39 40	47 48	63
Command Code	Data Address	Flags	Not Used	Count (Decimal)	
0100 0011 '43'	Specifies the main storage location of first byte of parameters	Used at the discretion of programmer	00		8

Description (Continued)

Operation Code Bits (4 through 7). These four bits define the following operations:

Bits 4-7	Operation
0100	Format defective block
0001	Write data
0101	Write and check data
0010	Read replicated data
0110	Read

Any other combination of bit settings is invalid and will cause the command to terminate with device end and unit check status.

Data transfer between the channel and storage director associated with these operations does not occur during execution of the Locate command. Data transfer is initiated by a read or write CCW following the Locate command.

Format Defective Block (0100): This operation code causes the storage director to flag the block specified by bytes 4 through 7 as defective. The storage director assigns an alternate block and establishes the appropriate backward and forward pointers.

If the mask specified in the Define Extent command inhibits format write operations, or if the Write Inhibit switch on the device is in the read-only mode, the Locate command is terminated with device end and unit check status.

Upon receipt of the format defective-block operation code, the storage director initiates an access to the first alternate block on the same physical cylinder as the defective block. The storage director then scans for the first unused alternate block. If there is not enough space in the alternate area of the same physical cylinder, the storage director initiates an access to the alternate area of the nearest physical cylinder and continues scanning. This process is repeated until an unused alternate block is found, or until all alternate space on the device has been scanned. If all alternate space has been used, the storage director signals unit check and device end status.

If an unused alternate block is located, the storage director saves the alternate block pointer and initiates an access to the defective block specified in bytes 4 through 7 of the parameters, verifies correct orientation, and formats the block identification (ID) with the defective flag bit on and the appropriate block pointer.

Format defective block operates on a single block only. Future references to the defective block cause the storage control to access the assigned alternate block.

There is no data transfer between the channel and storage control during the format defective block operation. All write data is generated internally by the storage control. Only the ID areas of the defective and alternate blocks are written. A Locate command specifying write data should be issued after the format defective block to write the data field of the block.

Locate

0	7 8	31 32	37 39 40	47 48	63
Command Code	Data Address	Flags	Not Used	Count (Decimal)	
0100 0011 '43'	Specifies the main storage location of the first byte of parameters	Used at the discretion of programmer	00		8

Description (Continued)

If the Locate command was preceded by a Diagnostic Control command with a subcommand of Displace ID, the storage director writes the block ID in its normal, displaced, or extended-displaced position according to the Displace ID subcommand. The storage director then performs a readback check on the block ID just written. If it is unreadable due to data errors, the operation is terminated with device end and unit check status.

If the Locate was not preceded by a Diagnostic Control command, the storage director writes the block ID in its normal position and performs a readback check on the block ID. If it is unreadable due to data errors, the storage director rewrites the block ID at a displaced position and performs another readback check. If the ID is still unreadable, the storage director rewrites the block ID at an extended-displaced position and performs another readback check. If the data is still unreadable, the operation is terminated with device end and unit check status.

In either case (with or without a preceding Diagnostic Control command) if the readback check is successful, the storage director initiates an access to the alternate block, verifies proper orientation, formats the alternate block ID with the appropriate flag byte and backward pointer, and presents device end status.

Write Data (0001): This operation code prepares the storage director to write one or more blocks of data. The number of blocks to be written is specified in the block count parameters of the Locate command (bytes 2 and 3). If the mask specified in the Define Extent command inhibits all write operations, or if the Write Inhibit switch on the device is in the read-only mode, the Locate command is terminated with device end and unit check status.

The write data operation establishes write orientation in the storage director for the addressed device.

Write data causes the storage control to initiate an access to the first block to be processed. The relative displacement of the first block specified by bytes 4 through 7 of the parameters is converted to the appropriate physical values for the addressed device. When the access to the block is complete, the device presents device end status.

Write and Check Data (0101): The storage director performs the same functions as described for the write data operation code and, in addition, performs a read back check on the data just written.

Read Replicated Data (0010): This operation code prepares the storage director to read one or more blocks of data from a range of replicated data. The number of blocks to be read is specified in the block count parameters (bytes 2 and 3). This operation establishes read orientation in the storage director for the addressed device.

Read replicated data causes the storage director to initiate an access to the first block of any unit of replicated data. Device end status is presented when the access is complete.

Locate

0	7 8	31 32	37 39 40	47 48	63
Command Code	Data Address	Flags	Not Used	Count (Decimal)	
0100 0011 '43'	Specifies the main storage location of the first byte of parameters	Used at the discretion of programmer	00		8

Description (Continued)

Read Data (0110): This operation code prepares the storage director to read one or more blocks of data. The number of blocks to be read is specified in the block count parameters (bytes 2 and 3).

Read data causes the storage director to initiate an access to the first block of data to be processed. The relative displacement of the first block specified by bytes 4 through 7 of the parameters is converted to the appropriate physical values for the addressed device. Device end is presented when the access is complete.

Byte 1

Byte 1 is the replication count. This byte is ignored if byte 0 specifies a format defective block. Byte 1 must be zero if byte 0 specifies read, write, or write and check data. When byte 0 specifies read replicated data (bits 4 through 7 = 0010), byte 1 specifies a range of blocks containing replicated data. The first block of this range is specified by the relative displacement in bytes 4 through 7 of the parameters.

The storage director orients to the beginning of a unit of replicated data to minimize rotational delay.

The block count (bytes 2 and 3 of the parameters) specifies the number of blocks in a unit of replicated data. For example, if the block count is two and this two-block unit is replicated five times, the replication count is ten.

If the replication count is less than the block count, or if the replication count is not a multiple of the block count, the Locate command is terminated with device end and unit check status.

If the replicated count equals the block count, the storage director converts the read replicated data operation to a read data operation.

Bytes 2 and 3

Bytes 2 and 3 are the block count parameters. They specify the number of sequential blocks to be processed by the command immediately following the Locate command. These bytes must not be zero or the Locate command terminates with device end and unit check.

Bytes 4 through 7

Bytes 4 through 7 specify the relative displacement, in blocks, from the beginning of the data set to the first block to be processed. The storage director compares the relative block displacement of the blocks to be processed against the logical extent limits established by the previously executed Define Extent command.

If the blocks to be processed are within the valid extent, the storage director processes the Locate command. If any block is not within the valid extent range, the Locate command is terminated with device end and unit check status.

Read

0	7 8	31 32	39 39 40	47 48	63
Command Code	Data Address	Flags	Not Used	Count (Decimal)	
0100 0010 '42'	Specifies the main storage location where the first byte of data is to be transferred	Used at the discretion of programmer			Specifies the number of bytes to be read

Function

The Read command causes data to be transferred from a device to the channel.

Chaining Requirements

The Read command must be chained from a Locate command or the command is rejected with channel end, device end, and unit check status.

Status

Initial status is normally zero. Channel end and device end are presented after the data is transferred to the channel. See the following description for conditions causing command termination and status associated with the termination.

Description

Upon receipt of the Read command, the storage director reads the block ID and verifies correct orientation.

Note: *If a Read command is chained from a Locate command and the storage director is not read oriented for this device, the Read command is terminated with channel end, device end, and unit check status. See the description of the Locate command for additional information regarding read orientation.*

After verification of orientation, the following 512-byte data block is read and transferred to the channel. This process is repeated until the block count specified in the preceding Locate command or the byte count specified in the Read CCW reaches zero. If the CCW count is greater than the byte count derived from the block count specified in the Locate command, data transfer stops when the block count reaches zero. If the CCW count is less than the byte count derived from the block count specified in the Locate command, data transfer stops when the CCW count reaches zero.

If a command overrun occurs on a Read CCW, the storage director signals retry status (channel or device end with status modifier and unit check) and disconnects. After re-orientation to the block, the storage director reconnects and continues the operation.

Command overrun may occur because of late channel reconnection on a record ready interrupt.

If a service overrun occurs while reading a block of data (other than the first block), the storage director terminates the operation with retry status. Unit check status is then posted on the retried Read CCW.

If the service overrun is in the first block, the storage director attempts recovery through the use of command retry. If retry is unsuccessful, the storage director terminates the command with channel end, device end, and unit check status.

If a data error is detected while reading a block ID, the storage director attempts recovery through the use of internal retry. After re-orientation to the block, the storage director continues the operation. If retry is unsuccessful, the storage director terminates the command with channel end, device end, and unit check status.

Read

0	7 8	31 32	37 39 40	47 48	63
Command Code	Data Address	Flags	Not Used	Not Used	Count (Decimal)
0100 0010 '42'	Specifies the main storage location where the first byte of data is to be transferred	Used at the discretion of programmer	00		Specifies the number of bytes to be read

Description (Continued)

If a correctable data error is detected while reading a data block, the command is terminated with retry status. Unit check status is then posted on the retried Read CCW. The sense data contains the data check and correctable bits along with the correction pattern bytes and displacement of the error so that the system error recovery procedures can correct the error. If the correctable error did not occur in the last data block for this CCW, operation incomplete is also set.

If an uncorrectable data error is detected in any data block except the first, the storage director terminates the command with retry status. Unit check status is then posted on the retried Read CCW. If the uncorrectable error is in the first block, the storage director attempts recovery through the use of command retry. If retry is unsuccessful, the command is terminated with channel end, device end, and unit check status.

An access error may occur on the Read CCW as a result of an access movement initiated by the storage director when an access boundary is encountered during a multiple block transfer or when a defective block is encountered. If an access error is detected before data transfer is initiated, the storage director attempts recovery through the use of command retry. If retry is unsuccessful, the command is terminated with channel end, device end, and unit check status. If the access error is detected after data transfer has been initiated, the command is terminated with channel end, device end, and unit check status.

Read Initial Program Load

0	7 8	31 32	37 39 40	47 48	63
Command Code	Data Address	Flags	Not Used	Count (Decimal)	
0000 0010 '02'	Specifies the main storage location where the first byte of data is to be transferred	Used at the discretion of programmer	00		Specifies the number of bytes to be transferred

Function

The Read Initial Program Load (IPL) command causes the storage director to orient to and then read block 0.

Chaining Requirements

The Read IPL command must be the first command in a chain or must be chained from another Read IPL command or the command is rejected with channel end, device end, and unit check status.

Status

Initial status is normally zero. Channel end and device end are presented after the data has been transferred to the channel.

Description

Upon receipt of the Read IPL command, the storage director establishes an extent of maximum allowable size with an offset of zero and a mask byte of zero. The storage director then orients to block zero and reads the entire block.

The Read IPL command will not transfer more than 512 bytes or transfer data from any block other than block 0.

If a service overrun occurs while reading block 0, the storage director attempts recovery through the use of command retry. If retry is unsuccessful, the storage director presents channel end, device end, and unit check status.

If a data check is detected in the block ID, the storage director attempts recovery through the use of internal retry. If retry is unsuccessful, the storage director presents channel end, device end, and unit check status.

If a correctable data check is detected in the data block, the storage director terminates the operation with retry status. Unit check status is then posted on the retried Read IPL CCW. The sense data contains the data check and correctable bits along with the correction pattern bytes and error displacement.

If an uncorrectable data check is detected in the data block, the storage director attempts recovery through the use of command retry. If retry is unsuccessful, the storage director presents channel end, device end, and unit check status.

Write

0	7 8	31 32	37 39 40	47 48	63
Command Code	Data Address	Flags	Not Used	Count (Decimal)	
0100 0001 '41'	Specifies the main storage location of the data to be written	Used at the discretion of programmer	00	Specifies the number of bytes to be written	

Function

The Write command causes data to be transferred from the channel to the storage director.

Chaining Requirements

The Write command must be chained from a Locate command or the command is rejected with channel end, device end, and unit check status.

Status

Initial status is normally zero. If write data is specified in the operation byte of the preceding Locate command, channel end and device end are presented after the data has been transferred to the storage director. See the following description for status presentation when write and check data is specified.

Description

Upon receipt of the Write command, the storage director reads the block ID and verifies correct orientation.

Note: *If the Write command is chained from a Locate command and the storage director is not write oriented for this device, the command is rejected with channel end, device end, and unit check status. See the description of the Locate command for additional information regarding write orientation.*

After verification of orientation, the following data block is written with data transferred from the channel. This process is repeated until the block count specified in the previous Locate command or the byte count specified in the Write CCW reaches zero.

If the CCW count is greater than the byte count derived from the block count specified in the Locate command, data transfer stops when the block count reaches zero. If the CCW count is less than the byte count derived from the Locate command, data transfer stops when the CCW count reaches zero.

If access boundaries are encountered during data transfer, the storage director performs the appropriate access movement.

If write and check data is specified in the preceding Locate command, the storage director re-initializes the block count and initiates an access back to the first block and presents channel end status. When the access is complete, the storage director reads the block ID and verifies correct positioning. The following data blocks are then read by the storage director, but the data is not transferred to the channel. After all blocks are read (block count equals zero), the storage director presents device end status.

Write

0	7 8	31 32	37 39 40	47 48	63
Command Code	Data Address	Flags		Not Used	Count (Decimal)
0100 0001 '41'	Specifies the main storage location of the data to be written	Used at the discretion of programmer	00		Specifies the number of bytes to be written

Description (Continued)

If a command overrun occurs on a Write CCW, the storage director signals retry status and disconnects from the channel. After re-orientation to the block, the storage director reconnects and continues the operation. (Command overrun may occur because of late channel reconnection on a record ready interrupt.)

If a service overrun occurs while writing a data block (other than the first block) when write data is specified in the preceding Locate command, the storage director terminates the command at the end of the data block with retry status (channel or device end with status modifier and unit check). Unit check status is then posted on the retried Write CCW.

If the service overrun occurs in the first block when write data is specified, or in any block when write and check data is specified, the storage director attempts recovery through the use of command retry. If the retry is unsuccessful, the command is terminated with channel end, device end, and unit check status.

If a data error is detected while reading a block ID to verify correct orientation, the storage director attempts recovery through the use of internal retry. After re-orientation to the block, the storage director continues the operation. If retry is unsuccessful, the command is terminated with channel end, device end, and unit check status.

If an uncorrectable data error is detected while reading a data block during a write - and check-data operation, the storage director terminates the operation and presents unit check status. Sense data indicates a check data error.

If a correctable data error is detected in a data block during a write - and check-data operation, the storage director continues the operation until the block count reaches zero. An access error may occur on the Write CCW as a result of an access movement initiated by the storage director when an access boundary is encountered during a multiple block transfer or when a defective block is encountered. If the access error occurs on a Write command with write data specified in the preceding locate command, the storage director attempts recovery through the use of command retry if the error occurred before data transfer or terminates the command with channel end, device end, and unit check status if the error was detected during data transfer.

If the access error is detected on a Write command with write and check data specified, the storage director attempts recovery through the use of command retry. If retry is unsuccessful, the command is terminated with channel end, device end, and unit check status.

If the access error is detected during the read-back check operation, the storage director uses internal retry for recovery. If recovery is unsuccessful, the storage director terminates the command with device end and unit check status.

Note: *Some software applications post the I/O operation as complete if a CSW is stored with unit status containing channel end only. As a result, a subsequent device end and unit check may not be made available to the user. This condition can occur if a Write CCW with write- and check-data specified in the preceding Locate command is the last CCW in the chain. Some software applications provide an option to delay posting until device end is received. If such an option is not provided, the user must take special action. A write sequence with verify that would otherwise terminate the chain must be followed by a non-write CCW (such as No-Op).*

Sense Input/Output

Command Code	Data Address	Flags	Not Used	Count (Decimal)
0000 0100 '04'	Specifies the main storage location where the first byte of sense data is to be transferred	Used at the discretion of programmer	00	24

Function

The Sense Input/Output (I/O) command transfers 24 bytes of sense information from the storage director to the channel.

Chaining Requirements

None.

Status

Initial status is normally zero. Channel end and device end are presented after the sense bytes are transferred.

Description

The sense information transferred by this command describes the reasons for unit check status, the current status of the device that performed the operation, and system error recovery information.

A unit check should always be followed by a Sense I/O command whether the information is used or not. Otherwise expected future interrupts may not occur and some I/O access paths may not be available.

A contingent connection state is established in the storage director after the channel accepts a status byte containing unit check. It lasts until a command (other than Test I/O or No-Op) receives an initial status byte of zero for the storage director and device address which generated the unit check. During the contingent connection state, the storage director is busy to all addresses other than the address for which the contingent connection was established.

Sense information is reset to zero after data transfer is complete, or when an initial status byte of zero is given to any command except Test I/O or No-Op.

Sense Input/Output Type

0	7 8	31 32	37 39 40	47 48	63
Command Code	Data Address	Flags	Not Used	Count (Decimal)	
1110 0100 'E4'	Specifies the main storage location where the first byte of sense data is to be transferred	Used at the discretion of programmer	00		7

Function

The Sense Input/Output (I/O) Type command transfers seven bytes of sense information from the storage director to the channel.

Chaining Requirements

None.

Status

Initial status is normally zero. Channel end and device end are presented after the sense bytes are transferred.

Description

The sense information transferred by this command describes the type and model of the storage control and device being addressed by this command.

The format of the sense bytes is as follows:

Byte	Description
0	Always FF
1	Storage control type number (38)
2	Storage control type number (80)
3	Storage control model number (01)
4	Device type number (33)
5	Device type number (70)
6	Device model number (00)

If the device is available and not busy, the Sense I/O Type command is executed even if the device is in the not-ready state.

The sense information is reset after execution of this command.

Read and Reset Buffered Log

0	7 8	31 32	37 39 40	47 48	63
Command Code	Data Address	Flags		Not Used	Count (Decimal)
1010 0100 'A4'	Specifies the main storage location where the first byte of usage and/or error information is transferred	Used at the discretion of programmer	00		24

Function

The Read and Reset Buffered Log command transfers 24 bytes of usage and/or error information from the storage director to the channel.

Chaining Requirements

None.

Status

Initial status is normally zero. Channel end and device end are presented after the usage/error information is transferred.

Description

The format of the usage/error information transferred to the channel is the same as the 24 bytes of sense information generated after the usage or error counters overflow. (See the Statistical Usage/Error Recording section of this manual.)

The usage/error statistics pertain to the logical device addressed by the Start I/O instruction. The statistics are reset to zero after data transfer is complete.

Read Device Characteristics

0	7 8	31 32	37 39 40	47 48	63
Command Code	Data Address	Flags	Not Used	Count (Decimal)	
0110 0100 '64'	Specifies the main storage location where the first byte of device characteristics information is to be transferred	Used at the discretion of programmer	00		32

Function

The Read Device Characteristics command transfers 32 bytes of device characteristic information from the storage director to the channel.

Chaining Requirements

None.

Status

Initial status is normally zero. Channel end and device end are presented after the data has been transferred.

Description

The information transferred by this command defines the characteristics of the addressed device. The device characteristics have the following format:

Byte	Bits	Description
0	0	Operation modes
	1	Reserved
	2	Overrunable
	3	On is burst mode and off is byte mode
	4	Data chaining allowed
	5-7	Reserved
1		Features
	0	Reserved
	1	Removable device
	2	Shared device
	3	Reserved
	4	Moveable access mechanism
	5-7	Reserved
2		Device class ('21')
3		Unit type ('02')
4, 5		Physical record size (512 bytes)
6, 9		Number of blocks per cyclical group (62)
10-13		Number of blocks per access position (744)
14-17		Number of blocks under movable access mechanism (558,000)
18-23		Reserved - all zeros.
24, 25		Number of blocks in the CE area (1488)
26-31		Reserved - all zeros.

If the addressed device is available and not busy but in the not-ready state, the command is not executed. Unit check is presented in initial status.

Device Reserve

0	7 8	31 32	37 39 40	47 48	63
Command Code	Data Address	Flags		Not Used	Count (Decimal)
1011 0100 'B4'	Specifies the main storage location where the first byte of sense data is to be transferred	Used at the discretion of programmer	00		24

Function

The Device Reserve command reserves the addressed device to the channel that issued the command if a channel switch feature is installed in the 3880 or if a string switch feature is installed in the 3370.

Chaining Requirements

The Device Reserve command must *not* be preceded by a Define Extent command in the same chain.

Status

Initial status is normally zero. Channel end and device end are presented after the 24 sense bytes have been transferred.

Description

In addition to reserving the addressed device, the Device Reserve command transfers the the 24 sense bytes to the channel.

A Device Reserve command will be executed regardless of any abnormal device status conditions (such as offline or unsafe).

Device reservation is maintained until the reserving channel successfully completes a Device Release command addressed to the reserved device.

Note: *A system reset cancels reservation of a device to the resetting channel only.*

Device Release

0	7 8	31 32	37 39 40	47 48	63
Command Code	Data Address	Flags	Not Used	Count (Decimal)	
1001 0100 '94'	Specifies the main storage location where the first byte of sense data is to be transferred	Used at the discretion of programmer	00		24

Function

The Device Release command terminates the reservation of the addressed device from the channel that issued the command if a channel switch feature is installed in the 3880 or if a string switch feature is installed in the 3370.

Chaining Requirements

The Device Release command must *not* be preceded by a Define Extent command in the same chain.

Status

Initial status is normally zero. Channel end and device end are presented after the 24 sense bytes have been transferred.

Description

In addition to terminating the reservation of the addressed device, the Device Release command transfers the 24 sense bytes to the channel.

A Device Release command will be executed regardless of any abnormal device status conditions (such as offline or unsafe).

Unconditional Reserve

0	7 8	31 32	37 39 40	47 48	63
Command Code	Data Address	Flags	Not Used	Count (Decimal)	
0001 0100 '14'	Specifies the main storage location where the first byte of sense data is to be transferred	Used at the discretion of programmer	00		24

Function

The Unconditional Reserve command breaks device allocation to the primary (failing) path and establishes allocation to the alternate path in the same system if a channel switch feature is installed in the 3880 or a string switch feature is installed in the 3370.

Chaining Requirements

The Unconditional Reserve command must be the first command in a chain or the command is rejected with channel end, device end, and unit check status.

Status

Initial status is normally zero. Channel end and device end are presented after the 24 sense bytes have been transferred.

Description

The Unconditional Reserve command is used to recover from hardware malfunctions. It performs all of the functions of the Device Reserve command and, in addition, reserves the device to the alternate path even when the device was reserved or in use through the primary path. Reservation or information in use for the primary path is reset in the device and storage director through which the command was issued. The Unconditional Reserve command does not reset information in the storage director which is now not operational.

Control of the device must be established by the system before the Unconditional Reserve command can be issued. Device control is established if the channel has the device reserved, or the channel has a CCW chain in progress (between the Start I/O instruction with a condition code of 0, and the ending interrupt). If the channel issues an Unconditional Reserve command to a device not assigned to it, one of the following conditions may occur on the other system.

- If the device is reserved, the reserve is reset and the device becomes reserved to the channel that issued the Unconditional Release command.
- An interrupt will be lost if the device is disconnected between chained commands.
- A recoverable equipment check is presented if the device is active when the command is executed.
- If the device is idle and not reserved, there is no effect.

If the system does not want the device reserved to the alternate path, it must issue a Device Release command. (The Device Release command may be chained to the Unconditional Reserve command.)

The Unconditional Reserve command will be executed regardless of any abnormal device status (such as offline or unsafe) unless the device does not respond to the selection tag (CC=3) or there is a preselection check (indicated by unit check status and equipment check in sense byte 0).

Diagnostic Control

0	7 8	31 32	37 39 40	47 48	63
Command Code	Data Address	Flags	Not Used	Count (Decimal)	
1111 0011 'F3'	Specifies the main storage location of the first byte of diagnostic control parameters	Used at the discretion of programmer	00		4 + N. See the description below for the value of N.

Function

The Diagnostic Control command transfers a minimum of four bytes of diagnostic control parameters from the channel to the storage director.

Chaining Requirements

The Diagnostic Control command must be preceded by a Define Extent command that allows diagnostics or the command is rejected with channel end, device end, and unit check status.

Status

Initial status is normally zero. See the following description for ending status presentation.

Description

The first four bytes of diagnostic control parameters transferred by this command have the following format:

Byte	Description
0	Subcommand identification
1	Subcommand identification modifier bits
2 and 3	Additional number of bytes to be transferred (N)

After the first four bytes have been transferred, the storage director checks the validity of the subcommand identification code and verifies that bytes 2 and 3 specify the correct number of additional bytes required for that subcommand. If an invalid parameter is detected, the Diagnostic Control command is terminated with channel end, device end, and unit check status.

If the parameters are valid, the channel transfers the additional number of bytes (specified in bytes 2 and 3) to the storage director.

If the CCW count is less than 4 + N, the command is terminated with channel end, device end, and unit check status. If the CCW count is greater than 4 + N, only 4 + N bytes are transferred.

Diagnostic Control

0	7 8	31 32	37 39 40	47 48	63
Command Code	Data Address	Flags	Not Used	Count (Decimal)	
1111 0011 'F3'	Specifies the main storage location of the first byte of diagnostic control parameters	Used at the discretion of programmer	00		4 + N. See the description below for the value of N.

Description (Continued)

Subcommands

Byte 0 specifies the subcommand to be performed. The following subcommands can be executed by the storage director:

Subcommand	Binary	Hexadecimal
Trace Dump	0000 0000	'00'
Format ID	0000 0100	'04'
Space ID and Read Data	0000 0110	'06'
Read ID	0000 1010	'0A'
Displace ID	0000 1111	'0F'

Trace/Dump Subcommand

Byte 0	1	2	3
Command Code	Modifiers	Additional Bytes Required	
'00'	'00'	'0000'	

The Trace/Dump subcommand is executed to prepare the storage director for a subsequent Diagnostic Sense/Read command that is to transfer the contents of the trace/dump buffer to the channel. This subcommand is used for diagnostic purposes only.

Format ID Subcommand

Byte 0	1	2	3
Command Code	Modifiers	Additional Bytes Required	
'04'	'00'	'0008'	

Byte 4	5	6	7	8	9	10	11
Block count	Flags (see note)		Cylinder address		Head address	Block number	

Note: Bytes 8 through 11 contain the physical address and block number. Bit 0 of byte 6 is the alternate area flag bit; bit 1 is the defective-block flag bit; bits 2, 3, and 4 are not used and must be set to zero; and bits 5, 6, and 7 are used as follows:

Diagnostic Control

0	7 8	31 32	37 39 40	47 48	63
Command Code	Data Address	Flags	Not Used	Count (Decimal)	
1111 0011 'F3'	Specifies the main storage location of the first byte of diagnostic control parameters	Used at the discretion of programmer	00		4 + N. See the description below for the value of N.

Description (Continued)

Format ID Subcommand (Continued)

Bits 5, 6, and 7	Description
000	ID not displaced
001	ID displaced once
010	ID displaced twice

All other combinations are invalid. Byte 7 is not used and must be set to 0.

The Format ID subcommand can be used for flagging an alternate block as defective, flagging an alternate block as unused, or for formatting a normal block. Execution of this subcommand causes the storage director to rewrite the block ID of the block specified by bytes 8 through 11 of the parameter list. Only one block is affected, and the block count specified in bytes 4 and 5 is ignored.

At the end of data transfer, the storage director checks the parameters for validity. The command is terminated with channel end, device end, and unit check status if any of the following conditions are detected:

- The Define Extent command inhibits format write operations.
- The device is in read-only mode.
- Bytes 8 through 11 contain a physical block address that is invalid for the addressed device.
- The Define Extent command mask byte (byte 0, bit 4) is off and bytes 8 through 11 address a block not in the data area.
- The Define Extent command mask byte (byte 0, bit 4) is on and bytes 8 through 11 address a block not in the CE area.
- The flag byte indicates a prime area (byte 6, bit 0 = 0) but the addressed block is not in the primary area.
- The flag byte indicates an alternate area (byte 6, bit 0 = 1) but the addressed block is not in the alternate area.
- Bytes 6 and 7 contain an invalid flag byte.
- The defective-block flag bit (byte 6, bit 1) is on but byte 6, bit 0 does not indicate an alternate area.

If all of the parameters are valid, the storage director initiates an access to the block and presents channel end status. When access to the block is completed, the storage director verifies correct orientation and writes the block ID. (The block ID is internally generated by the storage director.)

Diagnostic Control

0	7 8	31 32	37 39 40	47 48	63
Command Code	Data Address	Flags	Not Used	Count (Decimal)	
1111 0011 'F3'	Specifies the main storage location of the first byte of diagnostic control parameters	Used at the discretion of programmer	00	4 + N. See the description below for the value of N.	

Description (Continued)

Format ID Subcommand (Continued)

If the addressed block is in the alternate area, the alternate flag bit is set in the block ID field. If the defective-block flag bit is on (byte 6, bit 1), the block is flagged as defective with a null alternate/defective pointer and is written at a position indicated by bits 5 through 7 of byte 6. No data field is written for this operation and device end status is presented at the completion of the operation.

Space ID and Read Data Subcommand

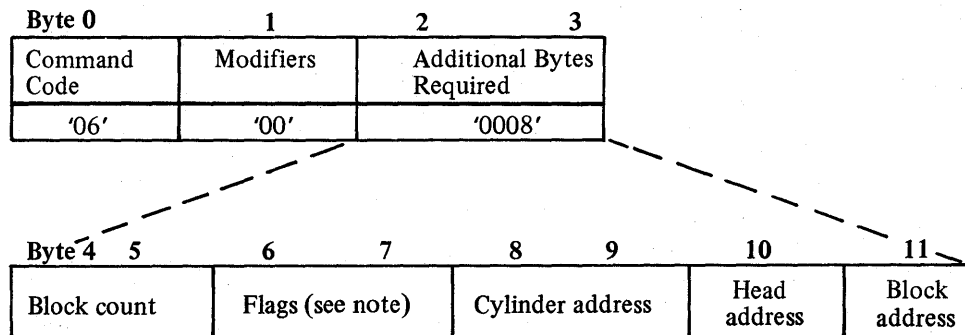

Note: Bit 0 of byte 6 indicates either prime area (bit off) or alternate area (bit on). All other bits in bytes 6 and 7 are unused and must be zero.

The Space ID and Read Data subcommand can be used to recover the data field of a block when the block ID has a permanent data check. Execution of this subcommand prepares the storage director to space over the block ID field and read the data field of the block specified in bytes 8 through 11 of the parameter list. Only one block is read and the block count in bytes 4 and 5 is ignored.

At the end of data transfer, the storage director checks the parameters for validity. If any of the following conditions are detected, the command is terminated with channel end, device end, and unit check status.

- Bytes 8 through 11 contain a physical address that is invalid for the addressed device.
- The Define Extent command mask byte (byte 0, bit 4) is off and bytes 8 through 11 address a block not in the data area.
- The flag byte (byte 6, bit 0) indicates an alternate area and the addressed block is not in the alternate area, or the flag byte indicates prime area and the block is not in the prime area.
- The Define Extent mask (byte 0, bit 4) is on and bytes 8 through 11 address a block not in the CE area.

Diagnostic Control

0	7 8	31 32	37 39 40	47 48	63
Command Code	Data Address	Flags	Not Used	Count (Decimal)	
1111 0011 'F3'	Specifies the main storage location of the first byte of diagnostic control parameters	Used at the discretion of programmer	00		4 + N. See the description below for the value of N.

Description (Continued)

If all the parameters are valid, the storage director initiates an access to the block and presents channel end status. When access to the block is completed, device end status is presented.

The actual operation of spacing over the block ID field and transferring the read data is performed by a subsequent Diagnostic Sense/Read command.

Read ID Subcommand

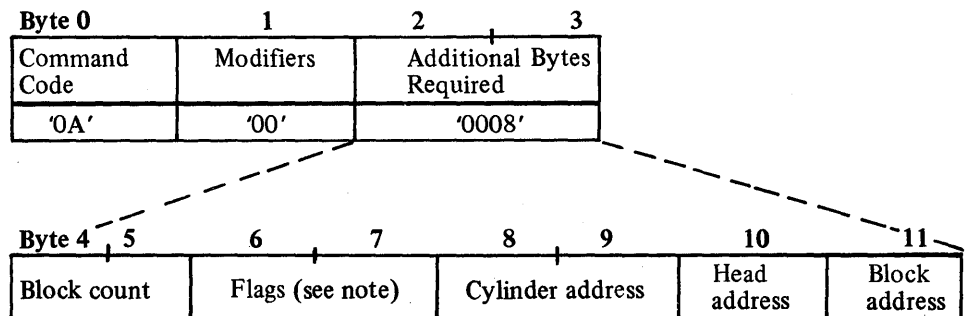

Note: Bit 0 of byte 6 indicates either prime area (bit off) or alternate area (bit on). All other bits in bytes 6 and 7 are unused and must be zero.

The Read ID subcommand is used to generate a defective block map for a device. Execution of this subcommand prepares the storage director to read one or more block IDs. The number of block IDs to be read is determined by the block count in bytes 4 and 5.

At the end of data transfer, the storage director checks the parameters for validity. If any of the following conditions are detected, the command is terminated with channel end, device end, and unit check status.

- The blocks specified are not within the limits of the addressed device. (Also, if the flag bit indicates prime area, the block addressed must be in the prime area; and if the flag bit indicates alternate area, the block addressed must be in the alternate area.)
- The Define Extent command mask byte (byte 0, bit 4) is off and bytes 8 through 11 address a block not in the data area.
- The Define Extent command mask byte (byte 0, bit 4) is on and bytes 8 through 11 address a block not in the CE area.

If all the parameters are valid, the storage director initiates an access to the block and presents channel end status. When access to the block is completed, device end status is presented.

The actual operation of reading the block IDs and transferring data to the channel is performed by a subsequent Diagnostic Sense/Read command. The storage director transfers five bytes of data to the channel for each block ID processed. The format of these five bytes is identical to the five bytes of block ID field written on the device. The block IDs processed are logically continuous either in the prime area or in the alternate area.

Diagnostic Control

0	7 8	31 32	37 39 40	47 48	63
Command Code	Data Address	Flags		Not Used	Count (Decimal)
1111 0011 'F3'	Specifies the main storage location of the first byte of diagnostic control parameters	Used at the discretion of programmer	00		4 + N. See the description below for the value of N.

Description (Continued)

Displace ID Subcommand

Command Code	Modifiers	Additional Bytes Required
'0F'		'0000'

'10' = Write ID of defective block in normal position.
 '20' = Write ID of defective block in displaced position.
 '40' = Write ID of defective block in extended displaced position.

The Displace ID subcommand is executed to prepare the storage director for a subsequent Locate command with an operation code specifying a format defective block. During execution of the format defective block operation, the ID of the defective block is written in the position indicated by the modifier bits in the Displace ID subcommand.

Diagnostic Sense/Read

0	7 8	31 32	37 39 40	47 48	63
Command Code	Data Address	Flags	Not Used	Count (Decimal)	
1100 0100 'C4'	Specifies the main storage location where the first byte of diagnostic information is to be transferred	Used at the discretion of programmer	00		See the description below.

Function

The Diagnostic Sense/Read command transfers diagnostic information from the storage director to the channel. The meaning and number of bytes transferred is determined by the preceding Diagnostic Control command. (See the description below.)

Chaining Requirements

Must be chained from a Diagnostic Control command or the command is rejected with channel end, device end, and unit check status.

Status

Initial status is normally zero. See the description below for ending status presentation.

Description

The data transferred by this command is determined by the subcommands in the preceding Diagnostic Control CCW.

Trace/Dump Subcommand

The contents of the trace/dump buffer are transferred to the channel. Channel end and device end are presented after data transfer. The trace/dump buffer is normally 4,096₁₀ bytes.

Format ID Subcommand

No data transfer takes place on this subcommand. Channel end and device end are presented in ending status.

Space ID and Read Data Subcommand

After verification of orientation, the storage director spaces over the block ID field of the next block on the same track and transfers the 512-byte data field to the channel. Channel end and device end are presented after data transfer.

Read ID Subcommand

After verification of orientation, the five-byte block ID field of the following block is read and transferred to a buffer in the storage director. If no ID data errors are detected, the block ID field is transferred from the storage director to the channel.

If an ID error was detected, the storage director attempts recovery through the use of internal retry. This read process continues until the block count reaches zero. If access boundaries are encountered during data transfer, the storage director automatically performs the appropriate access movement. Channel end and device end are presented after data transfer.

Diagnostic Sense/Read

0	7 8	31 32	37 39 40	47 48	63
Command Code	Data Address	Flags	Not Used	Count (Decimal)	
1100 0100 'C4'	Specifies the main storage location where the first byte of diagnostic information is to be transferred.	Used at the discretion of programmer	00		See the description below.

Description (Continued)

Read ID Subcommand (Continued)

If a command overrun occurs, the storage director signals retry status (channel or device end with status modifier and unit check) and disconnects. After re-orientation to the block, the storage director reconnects and continues the operation.

Command overrun may occur because of late channel reconnection on a disconnected command chain.

If a service overrun occurs while reading a block of data (other than the first block), the storage director terminates the operation with retry status. Unit check status is then posted on the retried CCW.

If the service overrun occurs in the first block, the storage director attempts recovery through the use of command retry. If retry is unsuccessful, the storage director terminates the command with channel end, device end, and unit check status.

If a data error is detected while reading a block ID, the storage director attempts recovery through the use of internal retry. After re-orientation to the block, the storage director continues the operation. If retry is unsuccessful, the storage director terminates the command with channel end, device end, and unit check status.

If a correctable data error is detected while reading a data block, the command is terminated with channel end, device end, and unit check status. The sense data contains the data check and correctable bits along with the correction pattern bytes and displacement of error. If the correctable data error did not occur in the last block for this CCW, operation incomplete is also set.

If an uncorrectable data error is detected in any data block except the first, the storage director terminates the command with retry status. Unit check status is then posted on the retried CCW. If the uncorrectable error is in the first block, the storage director attempts recovery through the use of command retry. If retry is unsuccessful, the command is terminated with channel end, device end, and unit check status.

An access error may occur as a result of an access movement initiated by the storage director when an access boundary is encountered during a multiple block transfer or when a defective block is encountered. If an access error is detected before data transfer is initiated, the storage director attempts recovery through the use of command retry. If retry is unsuccessful, the command is terminated with channel end, device end, and unit check status. If the access error is detected after data transfer has been initiated, the command is terminated with channel end, device end, and unit check status.

Displace ID Subcommand

No data transfer takes place on this subcommand. Channel end and device end are presented in ending status.

Channel Programs

The following channel programs are typical examples of how CCWs are arranged to read and write records with a 3880/3370 subsystem. The examples do not include the system control program used to initiate the channel programs.

Write

Example: Write three blocks of data in blocks 8840₁₀, 8841₁₀, and 8842₁₀ on the selected device. After writing the data, verify that it has been written correctly.

The channel program used is:

Define Extent
Locate
Write

Define Extent

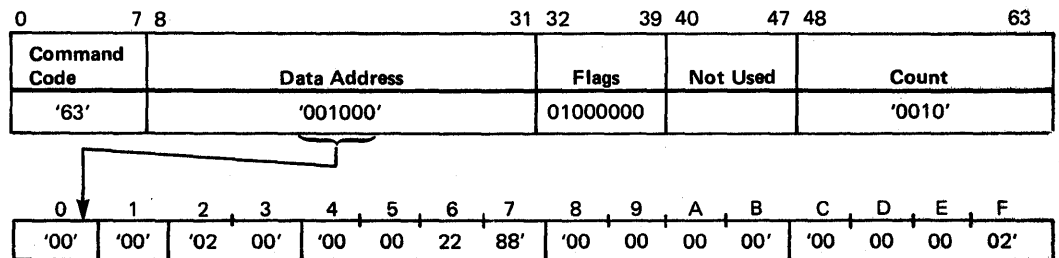

The parameters designated by the Define Extent command define the size and location of the data extent in which the following Locate and Write commands may operate. The parameters for this channel program are:

Byte 0 = '00'. This mask byte allows non-format write operations.

Byte 1 = '00'. This byte is not used and must be set to '00'.

Bytes 2 and 3 = '0200'. These bytes define the block size (512₁₀ bytes). If these bytes are zero, the block size defaults to 512₁₀.

Bytes 4 through 7 = '00002288' (8840₁₀). These bytes specify the *physical* block number of the first block of the extent. In this case, the data specified in the following Write command is written in physical blocks 8840₁₀, 8841₁₀, and 8842₁₀.

Bytes 8 through 11 = '00000000'. These bytes specify the *logical* block number of the first block in the extent. In this case, the data is written in the first three blocks of the extent so the logical block number of the first block is zero.

Bytes 12 through 15 = '00000002'. These bytes specify the logical block number of the last block in the extent. Three blocks (0, 1, and 2) are to be written, so block 2 is the last block of the extent.

Since the Locate command is to be chained to this command, the chain command flag (bit 33) is on in this CCW.

Write (Continued)

Locate

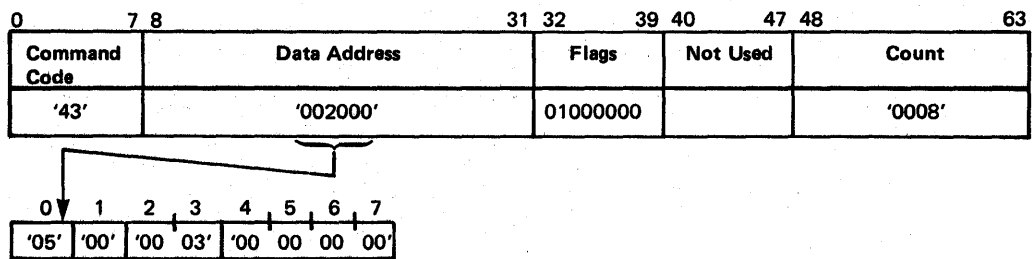

The parameters specified by the Locate command define the number of blocks to be written and the relative displacement of the first data block in the data set. The parameters for this channel program are:

Byte 0 = '05'. This byte specifies that the operation to be performed is write data with verify.

Byte 1 = '00'. This byte is not used for write operations and is set to '00'.

Bytes 2 and 3 = '0003'. These bytes specify the number of blocks to be written, in this case 3_{10} .

Bytes 4 through 7 = '00000000'. These bytes specify the relative displacement of the first block to be written from the beginning of the data set. In this case, these bytes are set to zero because the data is to be written in the first three blocks.

Write

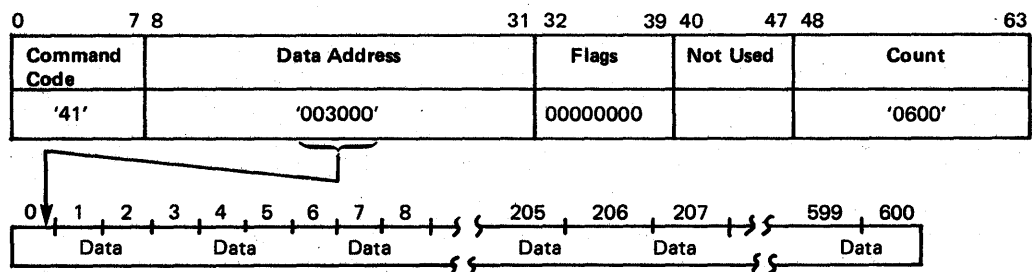

Execution of this command causes the data in main storage locations '003000' through '003600' to be written in the first three blocks of the data extent located at physical block number 8840_{10} . Since the preceding Locate command specified write data and verify, the data just written is read back (without transferring it to main storage), and the error correction code (ECC) bytes written at the end of the last block are compared with the ECC bytes generated on the read-back operation.

Since the Write command is the last command in the channel program, the chain command flag is off.

Read

Example: Read blocks 52₁₀ through 59₁₀ of a data set that is recorded in two extents. As shown below, the first extent begins at physical block number 50₁₀ and is 50₁₀ blocks long; the second extent begins at physical block number 147₁₀ and is 100₁₀ blocks long. Each block is 512₁₀ bytes.

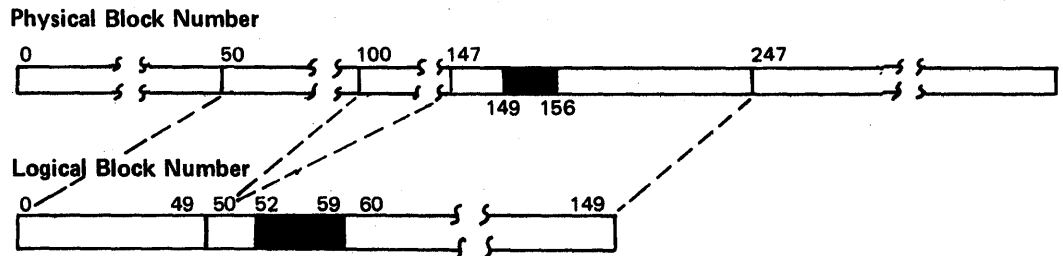

The channel program used is:

Define Extent
Locate
Read

Define Extent

Command Code	Data Address	Flags	Not Used	Count
'63'	'002000'	01000000		'0010'

0	1	2	3	4	5	6	7	8	9	A	B	C	D	E	F
'40'	'00'	'02	00'	'00	00	00	93'	'00	00	00	32'	'00	00	00	95'

The parameters designated by the Define Extent command define the size and location of data extent in which the following Locate and Read commands may operate. The parameters for this channel program are:

Byte 0 = '40'. This mask byte inhibits all Write and diagnostic commands and allows Read commands.

Byte 1 = '00'. This byte is not used and should be set to zero.

Bytes 2 and 3 = '0200'. These bytes define the block size. If these bytes are zero, the block size defaults to 512₁₀.

Bytes 4 through 7 = '00000093'. These bytes define the *physical* block number of the first block of the extent. In this case, 147₁₀.

Bytes 8 through 11 = '00000032'. These bytes specify the *logical* block number of the first block of the extent. In this case, 50₁₀.

Bytes 11 through 15 = '00000095'. These bytes specify the *logical* block number of the last block in the extent. In this case, 149₁₀.

Since the Locate command is to be chained from this command, the chain command flag (bit 33) is on in this CCW.

Read (Continued)

Locate

0	7 8	31 32	39 40	47 48	63
Command Code	Data Address	Flags	Not Used	Count	
'43'	'002428'	01000000			'0008'

0	1	2	3	4	5	6	7
'06'	'00'	'00	08'	'00	00	00	34'

The parameters specified by the Locate command define the number of blocks to be read and the relative displacement of the first block in the data set. The parameters for this channel program are:

Byte 0 = '06'. This byte specifies that the operation to be performed is read data.

Byte 1 = '00'. This byte is not used for this operation and should be set to '00'.

Bytes 2 and 3 = '0008'. These bytes specify the number of blocks to be read. In this case, 8_{10} .

Bytes 4 through 7 = '00000034'. These bytes specify the *logical* block number of the first block of data to be read. In this case, 52_{10} .

Since the Read command is to be chained from this command, the chain command flag (bit 33) is on in this CCW.

Read

0	7 8	31 32	39 40	47 48	63
Command Code	Data Address	Flags	Not Used	Count	
'42'	'003000'	00000000			'1000'

							'004000'
Data	Data	Data	Data	Data	Data	Data	Data

Execution of this command causes the data in physical blocks 149_{10} through 156_{10} to be read into main storage locations '003000' through '004000'.

Since the Read command is the last command in the channel program, the chain command flag is off.

Count, Key, and Data Command Set

Figure 8 is a summary of the count, key, and data (CKD) command set. This section of the manual contains a detailed description of each command and its use for 3330, 3333, 3340, 3344, and 3350 operations. Two additional commands, Set Path Group ID and Sense Path Group ID, are used to support the dynamic path selection function of the 3380. Five additional commands, Locate Record, Define Extent, Write Update Data, Write Update Key and Data, and Write CKD Next Track, are used to support attachment of the 3380 through the speed matching buffer feature. Information related to these commands and to the operation of the 3375 and the 3380 using the CKD command set will be provided in a later edition of this manual.

Command	Command Code			
	Multitrack Off		Multitrack On	
	Hexa- decimal	Binary	Hexa- decimal	Binary
Control				
No Operation (No-Op)	'03'	0000 0011		
Recalibrate	'13'	0001 0011		
Seek	'07'	0000 0111		
Seek Cylinder	'0B'	0000 1011		
Seek Head	'1B'	0001 1011		
Space Count	'0F'	0000 1111		
Set File Mask	'1F'	0001 1111		
Set Sector	'23'	0010 0011		
Restore	'17'	0001 0111		
Transfer-In-Channel (TIC)	'X8'*	xxxx1000		
Search				
Home Address Equal	'39'	0011 1001	'B9'	1011 1001
Identifier (ID) Equal	'31'	0011 0001	'B1'	1011 0001
Identifier (ID) High	'51'	0101 0001	'D1'	1101 0001
Identifier (ID) Equal or High	'71'	0111 0001	'F1'	1111 0001
Key Equal	'29'	0010 1001	'A9'	1010 1001
Key High	'49'	0100 1001	'C9'	1100 1001
Key Equal or High	'69'	0110 1001	'E9'	1110 1001
Read				
Home Address	'1A'	0001 1010	'9A'	1001 1010
Count	'12'	0001 0010	'92'	1001 0010
Record Zero (R0)	'16'	0001 0110	'96'	1001 0110
Data	'06'	0000 0110	'86'	1000 0110
Key and Data	'0E'	0000 1110	'8E'	1000 1110
Count, Key, and Data (CKD)	'1E'	0001 1110	'9E'	1001 1110
Multiple Count, Key and Data	'5E'	0101 1110		
Initial Program Load (IPL)	'02'	0000 0010		
Sector	'22'	0010 0010		
Sense				
Input/Output (I/O) Type	'E4'	1110 0100		
Input/Output (I/O)	'04'	0000 0100		
Read and Reset Buffered Log	'A4'	1010 0100		
Device Reserve	'B4'	1011 0100		
Unconditional Reserve	'14'	0001 0100		
Device Release	'94'	1001 0100		
Write				
Home Address	'19'	0001 1001		
Record Zero (R0)	'15'	0001 0101		
Erase	'11'	0001 0001		
Count, Key, and Data (CKD)	'1D'	0001 1101		
Special Count, Key, and Data	'01'	0000 0001		
Data	'05'	0000 0101		
Key and Data	'0D'	0000 1101		
Diagnostic				
Diagnostic Sense	'44'	0100 0100		
Diagnostic Load	'53'	0101 0011		
Diagnostic Write	'73'	0111 0011		
Diagnostic Sense/Read	'C4'	1100 0100		

* The X is not significant. The data addresses should not exceed storage capacity.

Figure 8. Summary of Count, Key, and Data Command Set

No-Operation

0	7 8	31 32	37 39 40	47 48	63
Command Code	Data Address	Flags	Not Used	Count (Decimal)	
0000 0011 '03'	Not checked for validity; should not exceed addressing capacity	SLI flag (bit 34) must be on	00	Must be nonzero to avoid a program check	

Function

The No-Operation (No-Op) command is used to maintain channel connection during I/O operations.

Chaining Requirements

None.

Status

Channel end and device end are presented in initial status.

Description

The No-Op command is processed as an immediate command. (Channel end is signaled immediately upon receipt of the command code.) It causes no action at the addressed device.

The No-Op command resets orientation information in the storage director. Indiscriminate usage of the No-Op command within CCW chains may cause records or parts of records to be skipped. For example, a No-Op inserted between a Read Count command and a Read Data command may cause the data area of the following record to be read. Also, a No-Op inserted between a command that reads the data area of record N-1 and a command that must process the count area of record N, may skip one or more records and process the count area of a subsequent record.

Recalibrate

Command Code	Data Address	Flags	Not Used	Count (Decimal)
0001 0011 '13'	Not checked for validity; should not exceed addressing capacity	SLI flag (bit 34) must be on	00	Must be nonzero to avoid a program check

Function

The Recalibrate command causes the addressed drive to seek to cylinder zero, head zero.

Chaining Requirements

None.

Status

Initial status is normally zero. Channel end is presented as ending status and device end is presented after the access is positioned at cylinder zero, head zero.

Description

The Recalibrate command is processed similarly to a seek command and the file mask must be set to allow seeks. Since this command is not processed as an immediate command and there is no data transfer involved, the suppress length indicator (SLI) flag must be on to avoid an incorrect length indication.

Seek

0	7 8	31 32	37 39 40	47 48	63
Command Code	Data Address	Flags	Not Used	Count (Decimal)	
0000 0111 '07'	Specifies the main storage location of the seek address	Used at the discretion of programmer	00		6

Function

The Seek command transfers the seek address from the channel to the storage director.

Chaining Requirements

None.

Status

Initial status is normally zero. Channel end and device end are presented after the seek address has been transferred. See the description below for other status conditions.

Description

The Seek command transfers the six-byte seek address from the channel to the storage director. The storage director saves the address to allow positioning of the access mechanism at a later time. If the seek address indicates that no access motion is required, the proper head is selected before channel end and device end status are presented.

The storage director checks the seek address for validity (see the following chart). If the seek address is not valid, channel end, device end, and unit check are presented in ending status if the Seek was the first command in a CCW chain. Otherwise, unit check status is presented alone.

The format for the seek address is:

Byte 0	1	2	3	4	5
0	0	C	C	H	H

Valid Seek Address	3330		3340 Only	3340	3344	3350
	Model 1	Model 11	(35 MB)	(70 MB)	(70 MB)	
Bytes 0, 1, and 4 must be:	0	0	0	0	0	0
Bytes 2 and 3 are not greater than:	410	814	348*	697*	697*	559*
Byte 5 is not greater than:	18	18	11	11	11	29
CE cylinders are:			349 and 350	698, 699 and 700	2,800 through 2,805	1,024 and 1,025
* Unless the file mask indicates CE cylinders.						

Seek

0	7 8	31 32	37 39 40	47 48	63
Command Code	Data Address	Flags	Not Used	Count (Decimal)	
0000 0111 '07'	Specifies the main storage location of the seek address	Used at the discretion of programmer	00		6

Description (Continued)

If access motion is required, it is not initiated until a Set Sector, read, search, write, or Space Count command is received in the same chain or until the CCW chain ends normally. If more than one Seek command is received in the CCW chain before access motion is initiated, only the last Seek command will cause access motion.

If the CCW chain ends normally and the last Seek command has not been initiated, the storage director initiates the seek after disconnecting from the channel. If the device is addressed by another command before the seek is completed, device end is not generated; but busy status is presented.

The Seek command does not have to be preceded by another CCW in order to be executed. However, if a Set File Mask command has been issued, the file mask must be set to allow seeks. (See the Set File Mask section of this manual.)

Execution of a Seek command resets track orientation information in the storage director.

Seek Cylinder

0	7 8	31 32	37 39 40	47 48	63
Command Code	Data Address	Flags	Not Used	Count (Decimal)	
0000 1011 '0B'	Specifies the main storage location of the seek address	Used at the discretion of programmer	00		6

Function

The Seek Cylinder command transfers the seek address from the channel to the storage director. This command performs the same functions as the Seek command.

Chaining Requirements

None.

Status

Initial status is normally zero. Channel end and device end are presented after the seek address has been transferred. See the description below for other status conditions.

Description

The Seek Cylinder command transfers the six-byte seek address from the channel to the storage director. The storage director saves the address to allow positioning of the access mechanism at a later time. If the seek address indicates that no access motion is required, the proper head is selected before channel end and device end status are presented.

The storage director checks the seek address for validity (see the following chart). If the seek address is not valid, channel end, device end, and unit check are presented in ending status if the Seek Cylinder was the first command in a CCW chain. Otherwise, unit check status is presented alone.

The format for the seek address is:

Byte 0	1	2	3	4	5
0	0	C	C	H	H

Valid Seek Address	3330		3340 Only	3340	3344	3350
	Model 1	Model 11	(35 MB)	(70 MB)	(70 MB)	
Bytes 0, 1, and 4 must be:	0	0	0	0	0	0
Bytes 2 and 3 are not greater than:	410	814	348*	697*	697*	559*
Byte 5 is not greater than:	18	18	11	11	11	29
CE cylinders are:			349 and 350	698, 699 and 700	2,800 through 2,805	1,024 and 1,025
* Unless the file mask indicates CE cylinders.						

Seek Cylinder

0	7 8	31 32	37 39 40	47 48	63
Command Code	Data Address	Flags	Not Used	Count (Decimal)	
0000 1011 'OB'	Specifies the main storage location of the seek address	Used at the discretion of programmer	00		6

Description (Continued)

If access motion is required, it is not initiated until a Set Sector, read, search, write, or Space Count command is received in the same chain or until the CCW chain ends normally. If more than one Seek command is received in the CCW chain before access motion is initiated, only the last Seek command will cause access motion.

If the CCW chain ends normally and the last Seek command has not been initiated, the storage director initiates the seek after disconnecting from the channel. If the device is addressed by another command before the seek is completed, device end is not generated, but busy status is presented.

The Seek Cylinder command does not have to be preceded by another CCW in order to be executed. However, if a Set File Mask command has been issued, the file mask must be set to allow seeks. (See the Set File Mask section of this manual.)

Execution of a Seek Cylinder command resets track orientation information in the storage director.

Seek Head

0	7 8	31 32	37 39 40	47 48	63
Command Code	Data Address	Flags	Not Used	Count (Decimal)	
0001 1011 '1B'	Specifies the main storage location of the seek address	Used at the discretion of programmer	00		6

Function

The Seek Head command transfers the seek address from the channel to the storage director.

Chaining Requirements

None.

Status

Initial status is normally zero. Channel end and device end are presented after the transfer of of the seek address.

Description

The Seek Head command transfers the six-byte seek address from the channel to the storage director. The storage director selects the drive and the proper head. Regardless of the value of the seek address cylinder bytes (bytes 0 through 3), no access motion is initiated.

Note: *Although the cylinder bytes are not used, they must contain a valid address.*

The storage director checks all six bytes of the seek address for validity (see the following chart). If the seek address is not valid, channel end, device end, and unit check are presented in ending status.

The format for the seek address is:

Byte 0	1	2	3	4	5
0	0	C	C	H	H

Valid Seek Address	3330		3340 Only	3340	3344	3350
	Model 1	Model 11	(35 MB)	(70 MB)	(70 MB)	
Bytes 0, 1 and 4 must be:	0	0	0	0	0	0
Bytes 2 and 3 are not greater than:	410	814	348*	697*	697*	559*
Byte 5 is not greater than:	18	18	11	11	11	29
CE cylinders are:			349 and 350	698, 699 and 700	2,800 through 2,805	1,024 and 1,025
* Unless the file mask indicates CE cylinders.						

The Seek Head command does not have to be preceded by another CCW in order to be executed. However, if a Set File Mask command has been issued, the file mask must be set to allow Seek Head commands. (See the Set File Mask section of this manual.)

Execution of a Seek Head command resets track orientation information in the storage director.

Space Count

0	7 8	31 32	37 39 40	47 48	63
Command Code	Data Address	Flags	Not Used	Count (Decimal)	
0000 1111 '0F'	Specifies the main storage location of the key and data lengths of the record to be recovered	Used at the discretion of programmer	00		3

Function

The Space Count command provides a means of recovering or bypassing a defective R0 count area, or provides a means of bypassing a bad count area of any record other than R0.

Chaining Requirements

The Space Count command cannot be chained from a Write Home Address, Write R0, Write CKD, Write Special CKD, or Erase command. It cannot be followed by any type of write command, Erase, Set File Mask, Read IPL, Device Reserve, or Device Release command in the same chain.

Status

Initial status is normally zero. See the description below for ending status presentation.

Description

The Space Count command is used for data recovery. It can be used to bypass or recover a defective R0 count area (the No leg of the decision block on the following page) or to bypass a defective count area (the Yes leg of the decision block).

Space Count

0	7 8	31 32	37 39 40	47 48	63
Command Code	Data Address		Flags	Not Used	Count (Decimal)
0000 1111 '0F'	Specifies the main storage location of the key and data lengths of the record to be recovered.		Used at the discretion of programmer	00	3

Description (Continued)

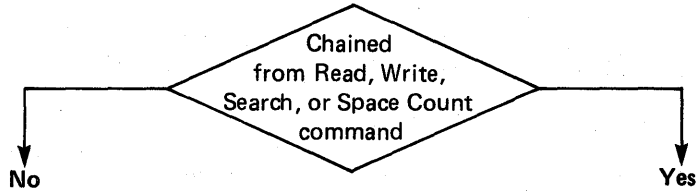

1. Searches for index.
2. Clocks through gap 1, home address and gap 2.
3. Spaces over R0 count area.
4. Receives key and data length from channel.
5. Sets end-of-count area internal orientation state indicator.
6. Presents channel end and device end to channel.

Using the above:

- a. Space Count followed by a Read Key and Data command recovers or bypasses a bad R0 count area.
- b. Space Count followed by a Read CKD reads R1.

1. Orients at start of next count area.
2. Spaces over the count area.
3. Receives key and data length from channel.
4. Sets end-of-count-area internal orientation state indicator.
5. Presents channel end and device end to channel.

Note: If the track is flagged as defective, the Space Count should always follow a Search ID Equal command to provide consistent results.

Using the above:

Command chain (a) may be used to recover key and data areas of record (N≠0). Command chain (b) may be used to recover record N + 1.

- | | |
|---|--|
| (a) Set Sector
Search ID
(record N-1)
TIC*-8
Space Count**
Read KD | (b) Set Sector
Search ID
(record N-1)
TIC*-8
Space Count**
Read CKD |
|---|--|

* Transfers to the address of the TIC command minus 8.

** Must specify correct key and data lengths.

The three bytes of data transferred from the channel are used as the key length (first byte) and the data length (last two bytes). If the CCW count is greater than three, only three bytes are transferred. If the CCW count is less than three, the number of bytes specified is transferred and a value of zero is assumed for the bytes not transferred.

Set File Mask

0	7 8	31 32	37 39 40	47 48	63
Command Code	Data Address	Flags	Not Used	Count (Decimal)	
0001 1111 '1F'	Specifies the main storage location of the mask byte	Used at the discretion of programmer	00	1	

Function

The Set File Mask command transfers one byte of data (the mask byte) from main storage to the storage director.

Chaining Requirements

The Set File Mask command cannot be issued more than once in the same CCW chain and cannot follow a Space Count command in the same chain.

Status

Initial status is normally zero. Channel end and device end are presented after the mask byte has been transferred to the storage director.

Description

The mask byte transferred by this command defines the write and seek operations that can be used in the CCW chain and defines command retry-PCI interaction. The chart on the following page describes the significance of each bit in the mask.

Set File Mask

0	7 8	31 32	37 39 40	47 48	63
Command Code	Data Address	Flag	Not Used	Count (Decimal)	
0001 1111 '1F'	Specifies the main storage location of the mask byte	Used at the discretion of programmer	00		1

Description (Continued)

Bits 0 and 1	Function
00	Inhibits Write Home Address and Write R0 commands.
01	Inhibits all write commands.
10	Inhibits all format write commands.
11	Permits all write commands.
Bit 2 must be zero or unit check, channel end, and device end are presented in initial status.	
Bits 3 and 4	Function
00	Permits all seek commands.
01	Permits Seek Cylinder and Seek Head commands.
10	Permits Seek Head commands.
11	Inhibits all seek commands and head switching.
Bit 5	Function
0	Inhibits Diagnostic Write commands and seeks to CE tracks only.
1	Permits Diagnostic Write commands and seeks to CE tracks only.
Bit 6 must be zero or unit check, channel end, and device end are presented in initial status.	
Bit 7*	Function
0	Not PCI fetch mode.
1	PCI fetch mode. The storage director presents unit check if command retry is used to recover from ECC uncorrectable errors.
*Bit 7 applies to 3330 and 3350 devices only. It is ignored by 3340/3344 devices.	

Any attempted violations of the file mask cause unit check status to be presented to the channel.

The mask is reset to all zeros at the end of the CCW chain or by a system or selective reset. Therefore, a Start I/O instruction following a reset (without a new Set File Mask command being issued) permits the program to execute all seek and write commands except Write Home Address, Write R0, and Diagnostic Write.

Execution of a Set File Mask command resets track orientation information in the storage director.

Set Sector

0	7 8	31 32	37 39 40	47 48	63
Command Code	Data Address	Flags	Not Used	Count (Decimal)	
0010 0011 '23'	Specifies the main storage location of the sector argument	Used at the discretion of programmer	00		1

Function

The Set Sector command transfers one byte of information (a relative angular track position) from main storage to the storage director.

Chaining Requirements

None.

Status

Initial status is normally zero. Channel end is presented after a valid angular position argument is received. Device end is presented when the desired angular position is reached.

Description

The Set Sector command, used on block multiplexer channels, allows the storage director to disconnect from the channel during rotational delay.

The storage director checks the byte transferred by the Set Sector command for validity. For 3330s and 3350s, the byte must contain a value between 0 and 127 or it may be 255.

For 3340s and 3344s the byte must contain a value between 0 and 63 or be set to 255. If the argument is not valid, the command is not executed; and channel end, device end, and unit check are presented as ending status.

If the Set Sector command is executed with an argument of 255, the storage director presents channel end and device end as ending status. No operation is performed and track orientation is destroyed.

If the Set Sector command is executed with an argument of zero, the storage director attempts reconnection just before index.

All valid Set Sector arguments, except 255, are adjusted by the storage director to compensate for channel reselection delay.

If a 3340 without rotational position sensing (RPS) is addressed, channel end and device end are presented in initial status. No operation is performed and track orientation is destroyed.

The Set Sector command does not guarantee record orientation. The search commands must still be used for this function.

Indiscriminate use of the Set Sector command with multitrack search may result in missing the desired record. A Set Sector (sector 0), Read Home Address and search multitrack sequence will avoid this problem.

See the Rotational Position Sensing section of this manual for additional information on the use of the Set Sector command.

Restore

Command Code	Data Address	Flags	Not Used	Count (Decimal)
0001 0111 '17'	Not checked for validity; should not exceed addressing capacity	SLI flag (bit 34) must be on	00	Must be nonzero to avoid program check

Function

The Restore command causes no action at the addressed device.

Chaining Requirements

None.

Status

Initial status is normally zero. Channel end and device end are presented as ending status immediately after initial status.

Description

The Restore command causes no action to be performed at the addressed device. It is maintained primarily for compatibility with other IBM direct access storage devices. Since this command is not processed as an immediate command and there is no data transfer involved, the SLI flag must be on to avoid an incorrect length indication. Execution of a Restore command resets track orientation information in the storage director.

Transfer-in-Channel

0	7 8	31 32	37 39 40	47 48	63
Command Code	Data Address	Flags	Not Used	Count (Decimal)	
XXXX 1000 'X8'	Specifies the main storage location of the next CCW	Ignored	00	Ignored	

Function

The Transfer-in-Channel (TIC) command provides chaining capabilities for CCWs not located in adjacent main storage locations.

Chaining Requirements

The TIC command cannot be the first CCW designated by the channel address word. One TIC command cannot transfer directly to another TIC command.

Status

No unit status is presented. The channel status portion of the CSW is stored if either of the special requirements is violated, or if the data address portion of the CCW does not specify an address on a doubleword boundary.

Description

The TIC command does not initiate any I/O operation at the channel, and the storage director and device are not signaled when the command is executed. The purpose of the TIC command is to provide chaining capabilities for CCWs not located in adjacent doubleword locations in main storage.

To address a CCW on integral boundaries for doublewords, the TIC command must contain zeros in bits 29 through 31.

The contents of bit positions 0 through 3 and 32 through 63 are ignored.

Search Home Address Equal

0	7 8	31 32	37 39 40	47 48	63
Command Code	Data Address	Flags	Not Used	Count (Decimal)	
0011 1001 '39' Multitrack: 1011 1001 'B9'	Specifies the main storage location of a cylinder number (CC) and a head number (HH)	Used at the discretion of programmer	00		4

Function

The Search Home Address Equal command causes the storage director to compare the four bytes of home address data from main storage with four bytes of home address data from the drive.

Chaining Requirements

None.

Status

Initial status is normally zero. Channel end and device end are presented if the comparison is not equal. Channel end, device end, and status modifier are presented when the comparison is equal.

Description

The execution of a Search Home Address Equal command causes the storage director to search for index. When index is detected, the storage director compares the cylinder and head numbers from main storage with the cylinder and head numbers from the track home address.

If the multitrack bit is off, the search is confined to one track. The search continues (as long as the channel repeats the command) until index is sensed again. When index is detected, channel end, device end, and unit check status are presented to the channel.

If the multitrack bit is on, the head number automatically increments when index is detected. The search then continues (as long as the channel repeats the command) until the search condition is satisfied or until the head number advances beyond the end of the cylinder (head 11 for 3340 and 3344, head 18 for 3330, and head 29 for 3350). Channel end, device end, and unit check status are presented at the end of the cylinder.

If the CCW count is greater than four bytes, only the first four bytes are used. Channel end and device end status are presented to terminate the command. Status modifier is also presented if the comparison was equal.

If the CCW count is less than four bytes, comparison of main storage and track data continues until the CCW count reaches zero. Channel end and device end status are presented after the home address and correction code bytes have been read and checked. Status modifier is also presented if the comparison was equal.

The validity of the data is verified by the correction code bytes following the home address area.

Search Identifier Equal

0	7 8	31 32	37 39 40	47 48	63
Command Code	Data Address	Flags	Not Used	Count (Decimal)	
0011 0001 '31' Multitrack: 1011 0001 'B1'	Specifies the main storage location of a five-byte record identifier (CC HH R)	Used at the discretion of programmer	00		5

Function

The Search Identifier (ID) Equal command causes the storage director to compare the five bytes (CC HH R) from main storage with the five-byte count area ID from the drive.

Chaining Requirements

None.

Status

Initial status is normally zero. Channel end and device end are presented if the comparison is not equal. Channel end, device end, and status modifier are presented when the comparison is equal.

Description

The execution of the Search ID Equal command causes the ID from main storage to be compared with the count area ID of the next record encountered on the track (including R0).

If the multitrack bit is off, the search is confined to one track. The search continues (as long as the channel repeats the command) until index is sensed again. When index is detected, channel end, device end, and unit check status are presented to the channel.

If the multitrack bit is on, the head number automatically increments when index is detected. The search then continues (as long as the channel repeats the command) until the search condition is satisfied or until the head number advances beyond the end of the cylinder (head 11 for 3340 and 3344, head 18 for 3330, and head 29 for 3350). Channel end, device end, and unit check status are presented at the end of the cylinder.

If the CCW count is greater than five bytes, only the first five bytes are used. Channel end and device end status are presented to terminate the command. Status modifier is also presented if the comparison was equal.

If the CCW count is less than five bytes, comparison of main storage and track data continues until the CCW count reaches zero. Channel end and device end status are presented after the count area correction code bytes have been read and checked. Status modifier is also presented if the comparison was equal.

The validity of the data is verified by the correction code bytes following the count area.

Search Identifier High

0	7 8	31 32	37 39 40	47 48	63
Command Code	Data Address	Flags	Not Used	Count (Decimal)	
0101 0001 '51' Multitrack: 1101 0001 'D1'	Specifies the main storage location of a five-byte record identifier (CC HH R)	Used at the discretion of programmer	00		5

Function

The Search Identifier (ID) High command causes the storage director to compare the five bytes (CC HH R) from main storage with the five-byte count area ID from the drive.

Chaining Requirements

None.

Status

Initial status is normally zero. Channel end, device end, and status modifier are presented if the ID on the drive is higher than the ID from main storage. Channel end and device end are presented when the ID from the drive is not higher.

Description

The execution of the Search ID High command causes the ID from main storage to be compared with the count area ID of the next record encountered on the track (including R0).

If the multitrack bit is off, the search is confined to one track. The search continues (as long as the channel repeats the command) until index is sensed again. When index is detected, channel end, device end, and unit check status are presented to the channel.

If the multitrack bit is on, the head number automatically increments when index is detected. The search then continues (as long as the channel repeats the command) until the search condition is satisfied or until the head number advances beyond the end of the cylinder (head 11 for 3340 and 3344, head 18 for 3330, and head 29 for 3350). Channel end, device end, and unit check status are presented at the end of the cylinder.

If the CCW count is greater than five bytes, only the first five bytes are used. Channel end and device end status are presented to terminate the command. Status modifier is also presented if the drive ID was higher than the ID from main storage.

If the CCW count is less than five bytes, comparison of main storage and track data continues until the CCW count reaches zero. Channel end and device end status are presented after the count area and correction code bytes have been read and checked. Status modifier is also presented if the drive ID is higher than the ID from main storage.

The validity of the data is verified by the correction code bytes following the count area.

Search Identifier Equal or High

0	7 8	31 32	37 39 40	47 48	63
Command Code	Data Address	Flags	Not Used	Count (Decimal)	
0111 0001 '71' Multitrack: 1111 0001 'F1'	Specifies the main storage location of a five-byte record identifier (CC HH R)	Used at the discretion of programmer	00		5

Function

The Search Identifier (ID) Equal or High command causes the storage director to compare the five bytes (CC HH R) from main storage with the five-byte count ID area from the drive.

Chaining Requirements

None.

Status

Initial status is normally zero. Channel end, device end, and status modifier are presented if the ID in the drive is equal to or higher than the ID from main storage. Channel end and device end are presented if the ID from the drive is not equal to or higher than the ID from the drive.

Description

The execution of the Search ID Equal or High command causes the ID from main storage to be compared with the count area ID of the next record encountered on the track (including R0).

If the multitrack bit is off, the search is confined to one track. The search continues (as long as the channel repeats the command) until index is sensed again. When index is detected, channel end, device end, and unit check status are presented to the channel.

If the multitrack bit is on, the head number automatically increments when index is detected. The search then continues (as long as the channel repeats the command) until the search condition is satisfied or until the head number advances beyond the end of the cylinder (head 11 for 3340 and 3344, head 18 for 3330, and head 29 for 3350). Channel end, device end, and unit check status are presented at the end of the cylinder.

If the CCW count is greater than five bytes, only the first five bytes are used. Channel end and device end status are presented to terminate the command. Status modifier is also presented if the comparison was equal or high.

If the CCW count is less than five bytes, comparison of main storage and track data continues until the CCW count reaches zero. Channel end and device end status are presented after the count area and correction code bytes have been read and checked. Status modifier is also presented if the comparison was equal or high.

The validity of the data is verified by the correction code bytes following the count area.

Search Key Equal

0	7 8	31 32	37 39 40	47 48	63
Command Code	Data Address	Flags	Not Used	Count (Decimal)	
0010 1001 '29' Multitrack: 1010 1001 'A9'	Specifies the main storage location to which the key is compared	Used at the discretion of programmer	00		Equal to the length of the argument

Function

The Search Key Equal command causes the storage director to compare the key data from main storage with the key area read from the track.

Chaining Requirements

None.

Status

Initial status is normally zero. Channel end, device end, and status modifier are presented if the key from main storage compares equally with the key from the track. Channel end and device end are presented if the comparison is not equal.

Description

The execution of the Search Key Equal command causes the key data from main storage to be compared with the next key area encountered on the track (excluding R0).

Note: *When this command is chained from a search ID or a Read Count command, the key compared is in the same record as the ID or count area. The Search Key Equal command bypasses R0 unless it is chained from a command that searched the ID of R0.*

If the multitrack bit is off, the search is confined to one track. The search continues (as long as the channel repeats the command) until index is sensed again. When index is detected, channel end, device end, and unit check status are presented to the channel.

If the multitrack bit is on, the head number automatically increments when index is detected. The search then continues (as long as the channel repeats the command) until the search condition is satisfied or until the head number advances beyond the end of the cylinder (head 11 for 3340 and 3344, head 18 for 3330, and head 29 for 3350). Channel end, device end, and unit check status are presented at the end of the cylinder.

If the CCW count is greater than the key length (KL), the search operation is completed when the key area is read. Channel end and device end status are presented to terminate the command. Status modifier is also presented if the comparison was equal.

The validity of the data is verified by the correction code bytes following the key area.

Search Key High

0	7 8	31 32	37 39 40	47 48	63
Command Code	Data Address	Flags	Not Used	Count (Decimal)	
0100 1001 '49' Multitrack: 1100 1001 'C9'	Specifies the main storage location to which the key is compared	Used at the discretion of programmer	00	Equal to the length of the argument	

Function

The Search Key High command causes the storage director to compare the key data from main storage with the key area read from the track.

Chaining Requirements

None.

Status

Initial status is normally zero. Channel end, device end, and status modifier are presented if the key from the drive is higher than the key from main storage. Channel end and device end are presented if the key from drive is not higher.

Description

The execution of the Search Key High command causes the key data from main storage to be compared with the next key area encountered on the track (excluding R0).

Note: *When this command is chained from a search ID or Read Count command, the key compared is in the same record as the ID or count area. The Search Key High command bypasses R0 unless it is chained from a command that searched the ID of R0.*

If the multitrack bit is off, the search is confined to one track. The search continues (as long as the channel repeats the command) until index is sensed again. When index is detected, channel end, device end, and unit check status are presented to the channel.

If the multitrack bit is on, the head number automatically increments when index is detected. The search then continues (as long as the channel repeats the command) until the search condition is satisfied or until the head number advances beyond the end of the cylinder (head 11 for 3340 and 3344, head 18 for 3330, and head 29 for 3350). Channel end, device end, and unit check status are presented at the end of the cylinder.

If the CCW count is greater than the key length (KL), the search operation is completed when the key area is read. Channel end and device end status are presented to terminate the command. Status modifier is also presented if the comparison was high.

If the CCW count is less than the KL, comparison of main storage and track data continues until the CCW count reaches zero. Channel end and device end are presented after the key area correction code bytes have been read and checked. Status modifier is also presented if the comparison was high.

The validity of the data is verified by the correction code bytes following the key area.

Search Key Equal or High

0	7 8	31 32	37 39 40	47 48	63
Command Code	Data Address	Flags		Not Used	Count (Decimal)
0110 1001 '69' Multitrack: 1110 1001 'E9'	Specifies the main storage location to which the key is compared	Used at the discretion of programmer	00		Equal to the length of the argument

Function

The Search Key Equal or High command causes the storage director to compare the key data from main storage with the key area read from the track.

Chaining Requirements

None.

Status

Initial status is normally zero. Channel end, device end, and status modifier are presented if the key from the drive is equal to or higher than the key from main storage. Channel end and device end are presented if the key from the drive is lower than the key from main storage.

Description

The execution of the Search Key Equal or High command causes the key data from main storage to be compared with the next key area encountered on the track (excluding R0).

Note: When this command is chained from a search ID or Read Count command, the key compared is in the same record as the ID or count area. The Search Key Equal or High command bypasses R0 unless it is chained from a command that searched the ID of R0.

If the multitrack bit is off, the search is confined to one track. The search continues (as long as the channel repeats the command) until index is sensed again. When index is detected, channel end, device end, and unit check status are presented to the channel.

If the multitrack bit is on, the head number automatically increments when index is detected. The search then continues (as long as the channel repeats the command) until the search condition is satisfied or until the head number advances beyond the end of the cylinder (head 11 for 3340 and 3344, head 18 for 3330, and head 29 for 3350). Channel end, device end, and unit check status are presented at the end of the cylinder.

If the CCW count is greater than the key length (KL), the search operation is completed when the key area is read. Channel end and device end status are presented to terminate the command. Status modifier is also presented if the comparison was equal or high.

If the CCW count is less than the KL, comparison of main storage and track data continues until the CCW count reaches zero. Channel end and device end status are presented after the key area correction code bytes have been read and checked. Status modifier is also presented if the comparison was equal or high.

The validity of the data is verified by the correction code bytes following the key area.

Read Home Address

0	7 8	31 32	37 39 40	47 48	63
Command Code	Data Address	Flags	Not Used	Count (Decimal)	
0001 1010 '1A' Multitrack: 1001 1010 '9A'	Specifies the main storage location where the home address is to be stored	Used at the discretion of programmer	00		5

Function

The Read Home Address command transfers the home address area of a track to main storage.

Chaining Requirements

None.

Status

Initial status is normally zero. Channel end and device end are presented after reading the home address correction code bytes.

Description

The Read Home Address command transfers the flag, cylinder, and head bytes of the home address area to the channel. The validity of the data read is verified by the correction code bytes following the home address area.

If a data overrun or data check is detected on a 3330 or a 3350 during the execution of this command, the storage director attempts recovery through the use of command retry. If command retry is unsuccessful, channel end, device end, and unit check status are presented to the channel.

Read Count

0	7 8	31 32	37 39 40	47 48	63
Command Code	Data Address	Flags	Not Used	Count (Decimal)	
0001 0010 '12' Multitrack: 1001 0010 '92'	Specifies the main storage location where the first byte of count data is to be transferred	Used at the discretion of programmer	00		8

Function

The Read Count command transfers the count area of a record from the drive to the channel.

Chaining Requirements

None.

Status

Initial status is normally zero. Channel end and device end are presented after reading the count area correction code bytes.

Description

The count area transferred by this command is the next count area (excluding R0) encountered on the track. The eight bytes transferred are the cylinder number (2 bytes), head number (2 bytes), record number (1 byte), key length (1 byte), and the data length (2 bytes).

The validity of the data is verified by the correction code bytes following the count area. If a data overrun or data check is detected on a 3330 or a 3350 during the execution of this command, the storage director attempts recovery through the use of command retry. If command retry is unsuccessful, channel end, device end, and unit check status are presented to the channel.

Read Record Zero

0	7 8	31 32	37 39 40	47 48	63
Command Code	Data Address	Flags	Not Used	Count (Decimal)	
0001 0110 '16' Multitrack: 1001 0110 '96'	Specifies the main storage location where the first byte of record zero count data is to be transferred	Used at the discretion of programmer	00		Specifies the number of count, key, and data bytes to be read

Function

The Read Record Zero (R0) command transfers the count, key, and data bytes of record zero from the drive to the channel.

Chaining Requirements

None.

Status

Initial status is normally zero. Channel end and device end are presented after reading the data area correction code bytes.

Description

Record 0, the track descriptor record, has the normal count, key, and data format and may be used as a normal data record. However, it is usually reserved by the operating system for nonuser functions.

During the execution of this command, the storage director searches for index, clocks through gap G1, home address, and gap G2, and transfers the count, key, and data areas of R0 to the channel.

Note: A Read R0 chained from a Read Home Address or Search Home Address command is executed immediately and does not cause a search for index.

The validity of each of the count, key, and data areas is verified by the correction code bytes following each of the areas.

If a data overrun or data check is detected on a 3330 or a 3350 during the execution of this command, the storage director attempts recovery through the use of command retry. If command retry is unsuccessful, channel end, device end, and unit check status are presented to the channel.

Read Data

0	7 8	31 32	37 39 40	47 48	63
Command Code	Data Address	Flags	Not Used	Count (Decimal)	
0000 0110 '06' Multitrack: 1000 0110 '86'	Specifies the main storage location where the first byte of data is to be transferred	Used at the discretion of programmer	00		Specifies the number of bytes to be read

Function

The Read Data command transfers the data area of a record from the drive to the channel.

Chaining Requirements

None.

Status

Initial status is normally zero. Channel end and device end are presented after reading the data area correction code bytes.

Description

The data area read by this command is either:

- The data area of the record following the next count area (excluding R0) encountered on the track
- The data area of the record that has been command chained from the count or key area of the same record (for example, a Read Data command chained from a Read Count command, or a Read Data command chained from a search ID or search key command)

The validity of the data is verified by the correction code bytes following the data area. If a data overrun or data check is detected on a 3330 or 3350 during the execution of this command, the storage director attempts recovery through the use of command retry. If command retry is unsuccessful, channel end, device end, and unit check status are presented to the channel.

If the data error is correctable, the correctable sense bit is set along with the pattern and displacement bytes of the error so that the system error recovery procedures can correct the error.

Read Key and Data

0	7 8	31 32	37 39 40	47 48	63
Command Code	Data Address	Flags	Not Used	Count (Decimal)	
0000 1110 '0E' Multitrack: 1000 1110 '8E'	Specifies the main storage location where the first byte of key data is to be transferred	Used at the discretion of programmer	00		Specifies the number of key and data bytes to be read

Function

The Read Key and Data command transfers the key and data areas of a record from the drive to the channel.

Chaining Requirements

None.

Status

Initial status is normally zero. Channel end and device end are presented after reading the data area correction code bytes.

Description

The key and data areas read by this command are either:

- The key and data areas of the record following the next count area (excluding R0) on the track
- The key and data areas of the record that has been command chained from the count area of the same record (for example, a Read Key and Data command chained from a Read Count command or a Read Key and Data command chained from a search ID command)

The validity of the data is verified by the correction code bytes following the key and data areas. If a data overrun or data check is detected on a 3330 or a 3350 during the execution of this command, the storage director attempts recovery through the use of command retry. If command retry is unsuccessful, channel end, device end, and unit check are presented to the channel at the end of the area in which the error occurred.

If a correctable data error is detected in the data area, the correctable sense bit is set along with the pattern and error displacement bytes so that the system error recovery procedures can correct the error.

Read Count, Key, and Data

0	7 8	31 32	37 39 40	47 48	63
Command Code	Data Address	Flags	Not Used	Count (Decimal)	
0001 1110 '1E' Multitrack: 1001 1110 '9E'	Specifies the main storage location where the first byte of count data is to be transferred	Used at the discretion of programmer	00		Specifies the number of count, key, and data bytes to be read

Function

The Read Count, Key, and Data command transfers the count, key, and data areas of a record from the drive to the channel.

Chaining Requirements

None.

Status

Initial status is normally zero. Channel end and device end are presented after reading the data area correction code bytes.

Description

The count, key, and data area of the record read by this command are from the next record (excluding R0) on the track.

The validity of the data is verified by the correction code bytes following each area. If a data overrun or data check is detected on a 3330 or a 3350 during the execution of this command, the storage director attempts recovery through the use of command retry. If command retry is unsuccessful, channel end, device end, and unit check status are presented to the channel at the end of the area in which the error occurred.

If a correctable data error is detected in the data area, the correctable sense bit is set along with the pattern and displacement bytes of the error so that the system error recovery procedures can correct the error.

Read Multiple Count, Key and Data

0	7 8	31 32	37 39 40	47 48	63
Command Code	Data Address	Flags	Not Used	Count (Decimal)	
0101 1110 '5E'	Specifies the main storage location where the first byte of data is to be transferred	Used at the discretion of programmer	00		Larger than maximum R1 capacity. 3330/3333 – 13,030 3340/3344 – 8,368 3350 native – 19,069

Function

The Read Multiple Count, Key and Data (CKD) command transfers the next record encountered (excluding R0) and all remaining records on the track from the storage director to the channel.

Chaining Requirements

The Read Multiple CKD command should be preceded by a Set File Mask command inhibiting head switching to avoid processing overflow records that may continue on the next track.

Status

Initial status is normally zero. Channel end and device end are presented after the last record on the track has been read.

Description

This command provides a means for reading all the records on a track in a single disk revolution. It is similar to executing a chain of Read CKD commands which reads records into contiguous main storage locations.

Reading starts at the next count field encountered (excluding R0) and continues until the last record on the track has been read. If a Read Multiple CKD command is issued after the count field of the last record on the track has been passed, channel end and device end status are presented and no data is transferred.

Since the actual number of bytes to be read is probably not known, the byte count should be greater than track capacity of the device. The CSW residual count, in conjunction with the CCW count, can be used to determine how many bytes were actually read.

Uncorrectable Data Checks: These checks are not retried by the storage director. Data check is set in the sense bytes and data transfer stops at the end of the area in which the error occurred.

Correctable Data Checks: These checks are not retried by the storage director. Displacement information is provided in the sense information to aid in constructing a restart CCW chain for error recovery.

Command Overruns: The storage director uses command retry when a command overrun is detected.

Data Overruns: These errors are not retried by the storage director. Data overrun is set in the sense information and system error recovery procedures are used to recover from the error.

Read Multiple Count, Key and Data

0	7 8	31 32	37 39 40	47 48	63
Command Code	Data Address	Flags	Not Used	Count (Decimal)	
0101 1110 '5E'	Specifies the main storage location where the first byte of data is to be transferred	Used at the discretion of programmer	00		Larger than maximum R1 capacity. 3330/3333 – 13,030 3340/3344 – 8,368 3350 native – 19,069

Description (Continued)

Seek Errors: These errors are not retried by the storage director. However, normally the Read Multiple CKD command would be preceded by a Read Home Address, Read R0, or a search ID command, and seek errors detected during the execution of these commands are retried.

The Read Multiple CKD command does not have to start at the beginning of a track. For example, if a track has 50 records and the key field of record 26 cannot be read, the following chain will read the first 25 records and detect the error in the key area of record 26:

- Read Home Address
- Read R0
- Read Multiple CKD

Analysis of the sense information, CSW residual count, CCW count, and the records already transferred to main storage, allows construction of the following chain:

- Search ID (record 26)
- TIC *-8
- Read Data
- Read Multiple CKD

This chain would recover the data area of record 26 and all subsequent records on the track. The only unrecovered data would be the key area of record 26.

Read Initial Program Load

0	7 8	31 32	37 39 40	47 48	63
Command Code	Data Address	Flags	Not Used	Count (Decimal)	
0000 0010 '02'	Specifies the main storage location where the first byte of data is to be transferred	Used at the discretion of programmer	00		Specifies the number of bytes to be read.

Function

The Read Initial Program Load (IPL) command causes the addressed device to seek to cylinder zero, head zero, and read the data area of record 1.

Chaining Requirements

The Read IPL command cannot be preceded by a Space Count or Set File Mask command in the same chain.

Status

Initial status is normally zero. Channel and end device end are presented after reading the data area correction code bytes.

Description

The Read IPL command is normally initiated by setting the address of the device in the Load Unit switches and pressing the IPL pushbutton on the system console. The command causes the addressed device to seek to cylinder zero, head zero, and search for index. When index is detected, the storage director clocks over record zero and reads the data area of record 1.

The validity of the data is verified by the correction code bytes following the data area. If a data overrun or data check is detected on a 3330 or 3350 during the execution of this command, the storage director attempts recovery through the use of command retry. If retry is unsuccessful, channel end, device end, and unit check status are presented to the channel at the end of the area in which the error occurred.

If a correctable data error is detected in the data area, the correctable sense bit is set along with the pattern and displacement bytes of the error so that system error recovery procedures can correct the error.

Read Sector

Command Code	Data Address	Flags	Not Used	Count (Decimal)
0010 0010 '22'	Specifies the main storage location where the sector number is to be stored	Used at the discretion of programmer	00	1

Function

The Read Sector command transfers one byte of data (sector number) from the storage director to the channel.

Chaining Requirements

None.

Status

Initial status is normally zero. Channel end and device end are presented after the sector number has been transferred.

Description

The byte transferred to the channel contains the angular position number required to access the last record processed on the drive. If no record has been processed since the last Set Sector command, the value is that set in the Set Sector command, minus four for the 3330 or 3350, or minus three for the 3340 or 3344.

If the last record processed was an overflow record, the angular position returned is that of the last segment.

A system reset or power-on sequence causes the sector value to be reset. Also, the execution of this command resets orientation information in the storage director.

If this command is issued to a device that does not have RPS, the byte returned to the channel will be '00'.

Sense Input/Output Type

0	7 8	31 32	37 39 40	47 48	63
Command Code	Data Address	Flags	Not Used	Count (Decimal)	
1110 0100 'E4'	Specifies the main storage location where the first byte of sense data is to be transferred	Used at the discretion of programmer	00		7

Function

The Sense Input/Output (I/O) Type command transfers seven bytes of sense information from the storage director to the channel.

Chaining Requirements

None.

Status

Initial status is normally zero. Channel end and device end are presented after the sense bytes are transferred.

Description

The sense information transferred by this command describes the type and model of the storage director and device being addressed by this command.

The format of the sense bytes is as follows:

Device Type	Always FF	Storage Control			Device		
	Byte 0	1	2	3	4	5	6
3330-1	FF	38	80	00	33	30	01
3330-11	FF	38	80	00	33	30	11
3340 (35 MB data module)	FF	38	80	00	33	40	01
3340 (70 MB data module)	FF	38	80	00	33	40	02
3344	FF	38	80	00	33	44	00
3350	FF	38	80	00	33	50	00

If the device is available and not busy, the Sense I/O Type command is executed even if the device is in the not-ready state.

Sense and track orientation information is reset after the execution of this command.

Sense Input/Output

0	7 8	31 32	37 39 40	47 48	63
Command Code	Data Address	Flag	Not Used	Count (Decimal)	
0000 0100 '04'	Specifies the main storage location where the first byte of sense information is to be transferred	Used at the discretion of programmer	00		24

Function

The Sense Input/Output (I/O) command transfers 24 bytes of sense information from the storage director to the channel.

Chaining Requirements

None.

Status

Initial status is normally zero. Channel end and device end are presented after the sense bytes are transferred.

Description

The sense information transferred by this command describes the reasons for unit check status, the current status of the device that performed the operation, and system error recovery information.

A unit check should always be followed by a Sense I/O command whether the information is used or not. Otherwise, expected future interrupts may not occur and some I/O access paths may not be available.

A contingent connection state is established in the storage director after the channel accepts a status byte containing unit check. This state lasts until a command (other than Test I/O or No-Op) receives an initial status byte of zero for the storage director and device address which generated the unit check. During the contingent connection state, the storage director is busy to all addresses other than the address for which the contingent connection was established. If no contingent connection exists, device type and feature information is generated and the rest of the sense bytes are set to zero.

Sense information is reset to zero after data transfer is complete or when an initial status byte of zero is given to any command except Test I/O or No-Op.

Execution of a Sense I/O command resets track orientation information in the storage director.

Sense information for the 3880 and its attached devices is described later in this manual.

Read and Reset Buffered Log

0	7 8	31 32	37 39 40	47 48	63
Command Code	Data Address	Flags	Not Used	Count (Decimal)	
1010 0100 'A4'	Specifies the main storage location where the first byte of usage/error information is to be transferred	Used at the discretion of programmer	00		24

Function

The Read and Reset Buffered Log command transfers 24 bytes of usage/error information from the storage director to the channel.

Chaining Requirements

None.

Status

Initial status is normally zero. Channel end and device end are presented after the usage/error information is transferred.

Description

The format of the usage/error information transferred to the channel is the same as the 24 bytes of sense information generated after the usage or error counters overflow. (See the Statistical Usage/Error Recording section of this manual.)

The usage/error statistics pertain to the logical device addressed by the Start I/O instruction. The statistics are reset to zero after data transfer is complete.

Execution of a Read and Reset Buffered Log command resets track orientation information in the storage director.

Device Reserve

0	7 8	31 32	37 39 40	47 48	63
Command Code	Data Address	Flags	Not Used	Count (Decimal)	
1011 0100 'B4'	Specifies the main storage location where the first byte of sense data is to be transferred	Used at the discretion programmer	00		24

Function

The Device Reserve command reserves the addressed device to the channel issuing the command.

Chaining Requirements

The Device Reserve command cannot be preceded by a Set File Mask or Space Count command in the same chain.

Status

Initial status is normally zero. Channel end and device end are presented after the 24 sense bytes have been transferred.

Description

In addition to reserving the addressed device, the Device Reserve command transfers the 24 sense bytes to the channel.

Reservation is maintained until a Device Release command is executed, or until the channel performs a system reset.

A channel switch feature must be installed in the storage director or the string switch feature must be installed in the controller attached to the storage director or the reserve function is not executed. In this case, channel end and device end are presented in ending status.

A Device Reserve command will be executed regardless of any abnormal device status conditions (such as offline or unsafe). However, with the string switch feature installed, this command will not be executed if the controller with the string switch does not respond when the storage director attempts to set the assignment indicator in the controller.

Execution of a Device Reserve command resets track orientation information in the storage director.

Unconditional Reserve

0	7 8	31 32	37 39 40	47 48	63
Command Code	Data Address	Flags	Not Used	Count (Decimal)	
0001 0100 '14'	Specifies the main storage location where the first byte of sense data is to be transferred	Used at the discretion of programmer	00		24

Function

The Unconditional Reserve command is used for 3330s, 3333s, and 3350s only. The Unconditional Reserve command breaks device allocation to the primary (failing) path and establishes allocation to the alternate path in the same system.

Chaining Requirements

The Unconditional Reserve command must be the first command in a chain or the command is rejected with channel end, device end, and unit check status.

Status

Initial status is normally zero. Channel end and device end are presented after the 24 sense bytes have been transferred.

Description

The Unconditional Reserve command is used to recover from hardware malfunctions. It performs all of the functions of the Device Reserve command and, in addition, reserves the device to the alternate path even when the device was reserved or in use through the primary path. Reservation or information in use for the primary path is reset in the device and storage director through which the command was issued. It does not reset information in the storage director which is now not operational.

The channel and/or string switch feature must be installed or the unconditional reserve function is not executed. In this case, channel end and device end are presented in ending status.

Control of the device must be established by the system before the Unconditional Reserve command can be issued. Device control is established if the channel has the device reserved, or the channel has a CCW chain in progress (between the Start I/O instruction with a condition code of 0, and the ending interrupt). If the channel issues an Unconditional Reserve command to a device not assigned to it, one of the following conditions may occur on the other system.

- If the device was reserved, the reservation is reset and the device becomes reserved to the channel that issued the Unconditional Release command.
- If the device is disconnected between chained commands, an interrupt will be lost.
- If the device is active when the command is executed, a recoverable equipment check will be presented.
- If the device is idle and not reserved, there is no effect.

If the system does not want the device reserved to the alternate path, it must issue a Device Release command. (The Device Release command may be chained to the Unconditional Reserve command.)

Execution of an Unconditional Reserve command resets track orientation information in the storage director.

Device Release

0	7 8	31 32	37 39 40	47 48	63
Command Code	Data Address	Flags	Not Used	Count (Decimal)	
1001 0100 '94'	Specifies the main storage location where the first byte of sense data is to be transferred	Used at the discretion of programmer	00	24	

Function

The Device Release command terminates the reservation of the addressed device.

Chaining Requirements

The Device Release command cannot be preceded by a Set File Mask or Space Count command in the same chain.

Status

Initial status is normally zero. Channel end and device end are presented after the 24 sense bytes have been transferred.

Description

In addition to terminating the reservation of the addressed device, the Device Release command transfers 24 sense bytes to the channel.

The channel switch feature must be installed in the storage director or the string switch feature must be installed in the controller attached to the storage director or the release function is not executed. In this case, channel end and device end are presented in ending status.

A Device Release command will be executed regardless of any abnormal device status conditions (such as offline or unsafe). However, with the string switch feature installed, this command will not be executed if the controller with the string switch does not respond when the storage director attempts to reset the assignment indicator in the controller.

Execution of a Device Release command resets track orientation information in the storage director.

Write Home Address

0	7 8	31 32	37 39 40	47 48	63
Command Code	Data Address	Flags	Not Used	Count (Decimal)	
0001 1001 '19'	Specifies the main storage location of the home address bytes	Used at the discretion of programmer	00		5 for 3330 7 for 3340 11 for 3350

Function

The Write Home Address command causes the home address area of a track to be transferred from main storage and written on the drive.

Chaining Requirements

The Write Home Address command must be chained from a successful Search Home Address command with a CCW count of four or more unless the command is used by a 3340, 3344, or 3350 to flag the track as defective. It must be preceded by a Set File Mask command that allows writing of the home address.

Status

Initial status is normally zero. Channel end and device end are presented after the correction code bytes have been written at the end of the home address area.

Description

One home address area is written on each track to establish track identity - a requirement to perform data operations on that track. The home address is normally written on the tracks by the disk manufacturer. The use of this command should be limited to identifying defective tracks and assigning alternate tracks. Utility programs are available to perform these functions.

During the execution of this command, the storage director orients on index and then writes gap G1, home address, and the correction code bytes. Bits 0 through 5 of the flag byte are generated by the storage director before the flag byte is transferred to the drive.

3330 Home Address Area

The home address area consists of a flag (1 byte), cylinder number (2 bytes), and a head number (2 bytes). If the CCW count is less than five, the storage director writes zeros in the remaining bytes. If the CCW count is greater than five, only five bytes are written.

3350 Home Address Area

The home address area consists of the skip displacement (6 bytes), flag (1 byte), cylinder number (2 bytes), and head number (2 bytes). If the CCW count is less than seven, the command is rejected. If the CCW count is less than 11, the storage director writes zeros in the remaining bytes. If the CCW count is greater than 11, only 11 bytes are written.

Note: Use of the Write Home Address command can cause loss of defect-skipping information recorded at the time of manufacture.

Write Home Address

0	7 8	31 32	37 39 40	47 48	63
Command Code	Data Address	Flags	Not Used	Count (Decimal)	
0001 1001 '19'	Specifies the main storage location of the home address bytes	Used at the discretion of programmer	00		5 for 3330 and 3333 7 for 3340 and 3344 11 for 3350

Description (Continued)

3340/3344 Home Address Area

The home address area consists of the skip displacement (2 bytes), flag (1 byte), cylinder number (2 bytes), and head number (2 bytes). If the CCW count is greater than seven, only the first seven bytes are written. If the CCW count is less than seven but three or more, the storage director writes zeros until seven bytes are written. If the CCW count is less than three, the command is rejected.

Note: *Use of the Write Home Address command can cause loss of defect-skipping information recorded at the time of manufacture.*

If a Write Home Address command is the last format write command in a chain, the remaining portion of the track is erased. If a command other than a Write R0 is chained from the Write Home Address, it is executed after the track is erased.

Write Record Zero

0	7 8	31 32	37 39 40	47 48	63
Command Code	Data Address	Flags	Not Used	Count (Decimal)	
0001 0101 '15'	Specifies the main storage location of the R0 count, key, and data bytes	Used at the discretion of programmer	00		Specifies the number of bytes in R0 count, key, and data areas

Function

The Write Record Zero (R0) command causes the count, key, and data areas of record zero to be transferred from main storage and written on the drive.

Chaining Requirements

The Write R0 command must be chained from a Write Home Address command or a Search Home Address Equal command whose argument was equal to four bytes (cylinder and head numbers) of the home address area.

Status

Initial status is normally zero. Channel end and device end are presented after writing the data area correction code bytes.

Description

Record 0, the track descriptor record, is always the first record on the track following the home address area. Although R0 may be used as a normal data record, it is usually reserved by the operating system to store pertinent track information.

The first eight bytes of data transferred are the count area: cylinder number (2 bytes), head number (2 bytes), record number (1 byte), key length (1 byte), and data length (2 bytes).

The remaining data sent from main storage is written in the key and data areas as specified by the values set in the key length (KL) and data length (DL) bytes.

The count field of the CCW specifies the total number of bytes to be transferred (8+KL+DL). If the count is less than 8+KL+DL, zeros are written in the remainder of the record. Correction code bytes are written at the end of the count area, end of the key area, and end of the data area.

If the Write R0 command is the last format write command in a chain, the remaining portion of the track is erased. If a command other than another format write is chained from the Write R0, it is executed after the track is erased.

Note: Record zero is normally written on the tracks by the disk manufacturer. The use of this command should be limited to identifying defective tracks and assigning alternate tracks. Utility programs are available to perform these functions. Proper operation with IBM operating systems requires a 0 key length and an 8-byte data field.

Erase

0	7 8	31 32	37 39 40	47 48	63
Command Code	Data Address	Flags	Not Used	Count (Decimal)	
0001 0001 '11'	Specifies the main storage location of the count, key, and data bytes	Used at the discretion of programmer	00	Specifies the number of count, key, and data bytes	

Function

The Erase command writes zeros in the count, key, and data areas of the specified record, then pads the remainder of the track with zeros.

Chaining Requirements

Must be chained from a Write R0, Write CKD, Search ID Equal, or Search Key Equal command. The search commands must have compared equal on all bytes.

Status

Initial status is normally zero. Channel end and device end are presented after the correction code bytes have been written at the end of the data area.

Description

This command is executed like a Write Count, Key, and Data command, except that zeros are written in each area. Although data is transferred from the channel, the erased record and all subsequent data on the track are not recoverable.

Write, Count, Key, and Data

0	7 8	31 32	37 39 40	47 48	63
Command Code	Data Address	Flags	Not Used	Count (Decimal)	
0001 1101 '1D'	Specifies the main storage location of the count, key, and data bytes	Used at the discretion of programmer	00		Specifies the number of bytes in the count, key, and data areas

Function

The Write Count, Key, and Data (CKD) command causes an entire record to be transferred from the main storage and written on the drive.

Chaining Requirements

The Write CKD command must be chained from a Write R0, Write CKD, Search ID Equal command. The search commands must have compared equal on all bytes of the searched field.

Note: A Read Data or Read Key and Data CCW may be inserted between a Search ID Equal and the Write CKD command. A Read Data command may be inserted between a Search Key Equal and the Write CKD command.

Status

Initial status is normally zero. Channel end and device end are presented after the correction code bytes have been written at the end of the data area.

Description

The count, key, and data areas of a record are transferred from main storage and written on the addressed device. The first eight bytes are the count area: cylinder number (2 bytes), head number (2 bytes), record number (1 byte), key length (1 byte), and data length (2 bytes).

The remaining data sent from main storage is written in the key and data areas as specified by the values set in the key length (KL) and the data length (DL) bytes.

The count field of the CCW specifies the total number of bytes to be transferred (8+KL+DL). If the CCW count is less than 8+KL+DL, zeros are written in the remainder of the record.

Correction code bytes are written at the end of the count area, at the end of the key area, and at the end of the data area.

If the Write CKD command is the last format-write command in a chain, the remaining portion of the track is erased. If a command other than another format write is chained from the Write CKD, it is executed after the track has been erased.

Write Special Count, Key, and Data

0	7 8	31 32	37 39 40	47 48	63
Command Code	Data Address	Flags	Not Used	Count (Decimal)	
0000 0001 '01'	Specifies the main storage location of the count, key and data bytes	Used at the discretion of programmer	00		Specifies the number of count, key, and data bytes in the record segment

Function

The Write Special Count, Key, and Data (CKD) command is used to format overflow records. (See the Record Overflow section of this manual.)

Chaining Requirements

The Write Special CKD command must be chained from a Write R0, Write CKD, Search Key Equal, or Search ID Equal command. The search commands must have compared equal on all bytes of the searched field.

Note: A Read Data or Read Key and Data command may be inserted between a Search ID Equal and the Write Special CKD command. A Read Data command may be inserted between a Search Key Equal and the Write Special CKD command.

Status

Initial status is normally zero. Channel end and device end are presented after the correction code bytes have been written at the end of the data area.

Description

This command is executed exactly the same as a normal Write CKD command except that the storage director writes a 1 in bit position 4 of the flag byte to indicate that it is a segment of an overflow record.

All segments of an overflow record are formatted with the Write Special CKD command except the last segment. The last segment is formatted with a normal Write CKD command.

During the execution of this command, the count, key, and data areas of a record are transferred from main storage and written on the addressed device. The first eight bytes transferred are the count area: cylinder number (2 bytes), head number (2 bytes), record number (1 byte), key length (1 byte) and data length (2 bytes).

The remaining data sent from main storage is written in the key and data area segment as specified by the values set in the key length (KL) and data length (DL) bytes.

The count field of the CCW specifies the total number of bytes to be transferred for the particular segment (8+KL+DL). If the CCW count is less than 8+KL+DL, zeros are written in the remainder of the segment.

Correction code bytes are written at the end of the count area, at the end of the key area, and at the end of the data area.

If the Write Special CKD command is the last format-write command in a chain, the remaining portion of the track is erased. If a command other than another format write is chained from the Write Special CKD command, it is executed after the track has been erased.

Write Data

0	7 8	31 32	37 39 40	47 48	63
Command Code	Data Address	Flags	Not Used	Count (Decimal)	
0000 0101 '05'	Specifies the main storage location of the data used to update a record	Used at the discretion of programmer	00	Specifies the number of bytes to be written	

Function

The Write Data command causes the specified data in main storage to be written in the data area of the selected record.

Chaining Requirements

The Write Data command must be chained from a Search ID Equal or Search Key Equal command that compared equally on all bytes of the searched field.

Status

Initial status is normally zero. Channel end and device end are presented after the correction code bytes have been written.

Description

The Write Data command is used to perform normal record updating after track formatting. The number of bytes to be written is specified in the count field of the Write Data CCW.

If the number of bytes specified in the CCW count is less than that specified in the count area data length (DL) bytes, the storage director writes zeros in the remaining data area and then writes the correction code bytes. If the CCW count is greater than the number of bytes specified in the count area DL bytes, only the number of bytes specified in the count area DL bytes are written. The storage director then writes the correction code bytes after the data area.

Write Key and Data

0	7 8	31 32	37 39 40	47 48	63
Command Code	Data Address	Flags	Not Used	Count (Decimal)	
0000 1101 '0D'	Specifies the main storage location of the data used to update a record	Used at the discretion of programmer	00	Specifies the number of bytes to be written	

Function

The Write Key and Data command causes the specified data in main storage to be written in the key and data areas of the selected record.

Chaining Requirements

The Write Key and Data command must be chained from a Search ID Equal command that compared equally on all bytes of the search field.

Status

Initial status is normally zero. Channel end and device end are presented after the correction code bytes have been written at the end of the data area.

Description

The Write Key and Data command is used to perform normal updating of the key and data areas after track formatting. The number of bytes to be written is specified in the count field of the Write Key and Data CCW. If the number of bytes specified in the CCW count is less than that specified in the count area key length (KL) and data length (DL) bytes, the storage director writes zeros in the remaining area. If the CCW count is greater than the number of bytes specified in the KL and DL bytes, only the number of bytes specified in the KL and DL bytes are written.

Correction code bytes are written after the key and data areas.

Diagnostic Sense

0	7 8	31 32	37 39 40	47 48	63
Command Code	Data Address	Flags	Not Used	Count (Decimal)	
0100 0100 '44'	Specifies the main storage location where the first byte of error code message accumulated during a previous Diagnostic Write command is to be transferred	Used at the discretion of programmer	00		16

Function

The Diagnostic Sense command transfers the error code message accumulated during a previous Diagnostic Write command from the storage director to main storage.

Chaining Requirements

The Diagnostic Sense command should be chained from a Diagnostic Write command.

Status

Initial status is normally zero. Channel end and device end are presented after data transfer.

Description

The execution of a Diagnostic Sense command that is chained to a Diagnostic Write command causes 16 bytes of error code information to be transferred to main storage. The error code information was accumulated during execution of the previous Diagnostic Write command. When chained to a Diagnostic Write command, the CCW count field should be set to 16.

Note: This command is intended for maintenance purposes only. Any use other than that provided by IBM diagnostic programs may yield unpredictable results.

Diagnostic Load

Command Code	Data Address	Flags		Not Used	Count (Decimal)
0101 0011 '53'	Specifies the main storage location of the control byte for diagnostic test	Used at the discretion of programmer	00		1

Function

The Diagnostic Load command transfers one byte of control information (diagnostic program ID number) from main storage to the storage director.

Chaining Requirements

None.

Status

Initial status is normally zero. Channel end and device end are presented after the diagnostic program has been transferred from the diagnostic diskette to a buffer in the storage director.

Description

The control byte transferred by the Diagnostic Load command specifies the program ID number of the diagnostic test that is to be transferred from the diskette to the buffer.

When addressing the storage director, the address of any device attached to the storage director may be used with the Diagnostic Load command.

Note: *This command is intended for maintenance purposes only. Any use other than that provided by IBM diagnostic programs may yield unpredictable results.*

Diagnostic Write

0	7 8	31 32	37 39 40	47 48	63
Command Code	Data Address	Flags	Not Used	Count (Decimal)	
0111 0011 '73'	Specifies the main storage location of the diagnostic test	Used at the discretion of programmer	00		8

Function

The Diagnostic Write command transfers 8 bytes of data from main storage to the storage director and initiates execution of the diagnostic test previously loaded by a Diagnostic Load command.

Chaining Requirements

The Diagnostic Write command must be preceded by a Set File Mask command which allows the execution of Diagnostic Write commands. (See the Set File Mask section of this manual.)

Status

Initial status is normally zero. Channel end and device end are presented after the test has been transferred, run, and the results stored in a buffer in the storage director.

Description

The diagnostic test run had previously been loaded by a Diagnostic Load command. After data transfer is complete, the test is run and a 16-byte error code is stored in a buffer in the storage director.

A subsequent Diagnostic Sense command transfers the error code to main storage.

Note: This command is intended for maintenance purposes only. Any use other than that provided by IBM diagnostic programs may yield unpredictable results.

Diagnostic Sense/Read

0	7 8	31 32	37 39 40	47 48	63
Command Code	Data Address	Flags	Not Used	Count (Decimal)	
1100 0100 'C4'	Specifies the main storage location where the first byte of diagnostic information is to be transferred	Used at the discretion of programmer	00		4,092 (maximum)

Function

The Diagnostic Sense/Read command transfers the contents of the trace/dump buffer from the storage director to the channel.

Chaining Requirements

None.

Status

Initial status is normally zero. Channel end and device end are presented after the contents of the trace/dump buffer have been transferred to the channel.

Description

The trace/dump buffer contains information about channel interface sequences, microcode sequences, and status information that is used by the customer engineer to isolate hardware failures.

Note: This command is intended for maintenance purposes only. Any use other than that provided by IBM diagnostic programs may yield unpredictable results.

Channel Programs

The following channel programs are typical examples of how CCWs are arranged to format, read, and write records using a 3880 with a 3330 series disk storage, a 3340 disk storage with the RPS feature, or a 3350 disk storage. These examples do not include the system control program used to start the channel program.

Track Formatting

Example: Format track '6A' on head '08' with records R1, R2, and R3 for customer records. Assume the R0 has a key length (KL) of zero and a data length (DL) of eight bytes, and that R1, R2, and R3 have a key length of six bytes and a data length of '0064' (100₁₀) bytes.

The channel program is:

Seek
 Set File Mask
 Set Sector
 Search ID Equal (R0)
 TIC*-8
 Write CKD
 Write CKD
 Write CKD

Seek

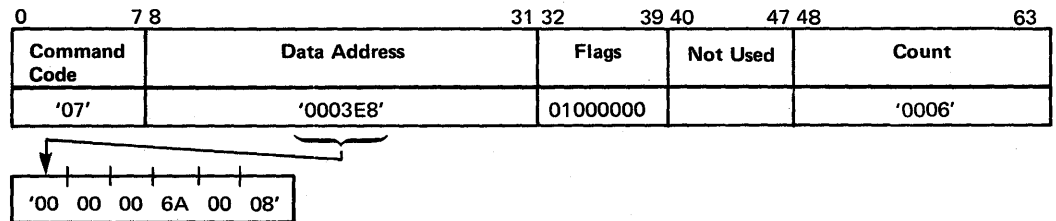

All Seek commands transfer six bytes of data from main storage to the storage director (count = 6). The first two seek address bytes are always zeros, the cylinder number ('006A') is specified in the bytes 3 and 4, and bytes 5 and 6 indicate the required head ('0008'). The seek address is saved in the storage director.

Set File Mask

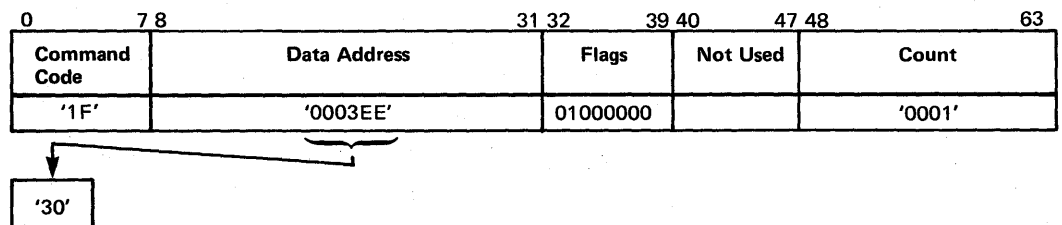

The Set File Mask command specifies the types of operations that can be performed in this channel program. The mask byte in this case ('30') permits format write commands and inhibits seek commands. The mask is reset to zero at the beginning of each command chain.

Track Formatting (Continued)

Set Sector

0	7 8	31 32	39 40	47 48	63
Command Code	Data Address	Flags	Not Used	Count	
'23'	'001390'	01000000			'0001'

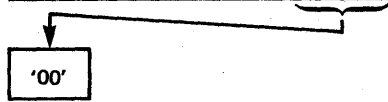

Execution of a Set Sector command with an argument of zero, orients the track to index. During the time the storage director is waiting for index, the channel is available to perform other operations. If the previous Seek command indicated that access motion was required, the access mechanism is positioned while the storage director is disconnected from the channel.

Search ID Equal

0	7 8	31 32	39 40	47 48	63
Command Code	Data Address	Flags	Not Used	Count	
'31'	'0003EF'	01000000			'0005'

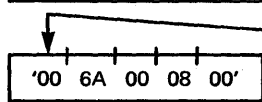

The Search ID Equal command causes the first ID found on the track to be compared with the argument. All unequal comparisons of IDs cause the 3880 to signal channel end and device end to the channel causing the TIC command (back to Search ID Equal) to be executed. When an equal comparison is found (ID of record 0), the 3880 signals channel end, device end, and status modifier to the channel. The status modifier causes the next command (TIC) to be skipped and the first Write CKD command to be executed.

Transfer-In-Channel (TIC)

0	7 8	31 32	39 40	47 48	63
Command Code	Data Address	Flags	Not Used	Count	
'X8'	Address of the last command	XXXXXXXX			'XXXX'

TIC*-8 branches back to the last command address.
X = positions ignored.

Track Formatting (Continued)

Write CKD

0	7 8	31 32	39 40	47 48	63
Command Code	Data Address	Flags	Not Used	Count	
'1D'	R1-'000BB8' R2-'000FA0' R3-'001388'	011000 011000 001000			'0008' '0008' '0008'

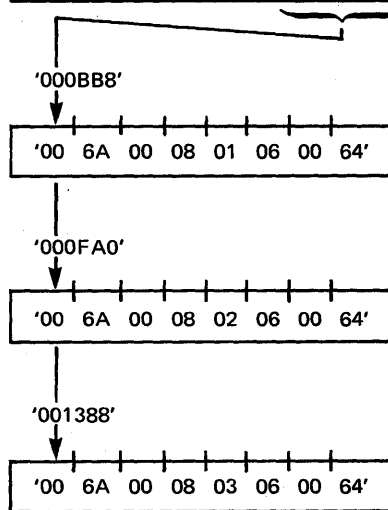

Execution of the Write CKD commands causes a count area, key area (if not zero), and the data area with the length specified by the DL bytes, to be written on the disk.

The main storage locations specified in the data address are coded with the cylinder number, head number, record number, key length, and data length of each record. Since the KL = '06', a key area of six bytes is created. The data length specified is '0064' (100₁₀) bytes. Although the CCW byte count is only eight, and the channel byte count goes to zero after eight bytes are written, the storage director is committed to write a key area six bytes long and a data area 100 bytes long. Therefore, the storage director inserts zeros in the applicable track positions until the byte count reaches zero.

The difference in the channel byte count and the storage director byte count causes an incorrect length indication, so the SLI flag (bit 34) is set in the CCWs.

In this example, six bytes of zeros are recorded in the key area and followed by the ECC bytes, a gap, 100 bytes of zeros, and more ECC bytes. The data that replaces the zeros can be recorded in the key and data areas at a later time with the following CCW sequence:

- Set Sector
- Search ID Equal (R1)
- TIC*-8
- Write KD
- Search ID Equal (R2)
- etc.

Update Write

Example: Update Frank Smith's record. Assume that the disk is organized by key areas. Each key area contains an employee number. Frank Smith's number is 656151. This number is located in cylinder '0C', head '04'. The key areas are six bytes long and the data areas are '64' (100₁₀) bytes long.

The channel program is:

```

Seek
Set File Mask
Search Key Equal
TIC*-8
Write Data
  
```

Seek

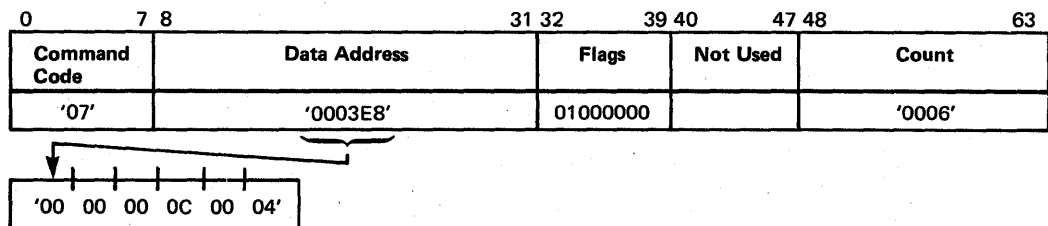

As explained in the track formatting example, the Seek command saves the seek address for later execution.

Set File Mask

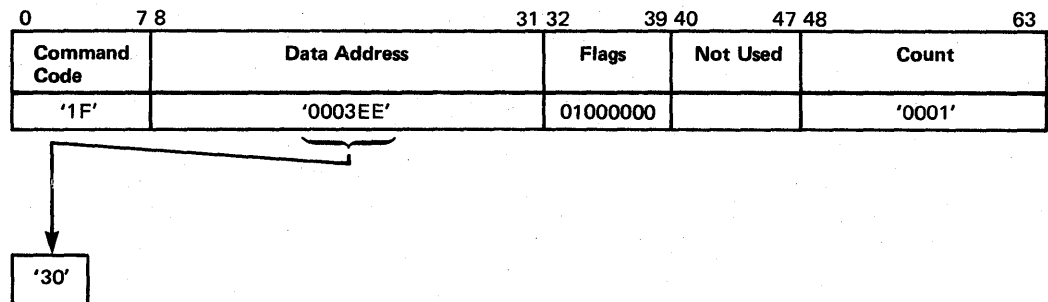

The Set File Mask command specifies the types of operations that can be performed in this channel program. The mask byte in this case ('30') permits all write commands and inhibits all seek commands. The mask is reset to zero at the beginning of each command chain.

Update Write (Continued)

Search Key Equal

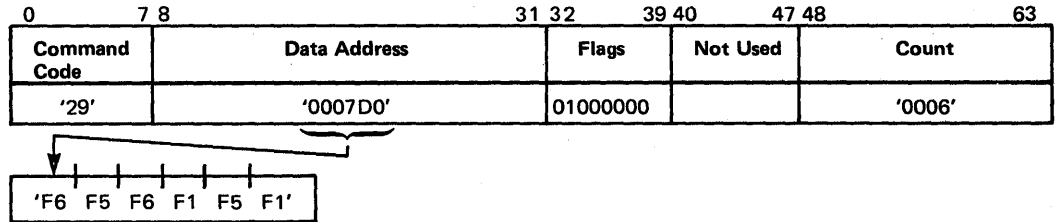

If the previous Seek command indicated access motion was required, command retry is indicated and the access mechanism is moved to the proper location before retrying the Search Key Equal command. After locating the correct cylinder and track, Frank Smith's record must be found. Since the disk is organized by keys, a Search Key Equal command is executed. This causes the storage director to search the key area of the next record on the track. If the key is not equal to Frank Smith's number (main storage locations '07D0' through '07D5'), the storage director signals channel end and device end to the channel and the TIC command (return to Search Key Equal) is executed. This continues until the correct record is found. The storage director then sends channel end, device end, and status modifier to the channel. The status modifier bit in the status byte causes the channel to skip the next command (TIC) and execute the Write Data command.

Transfer-In-Channel (TIC)

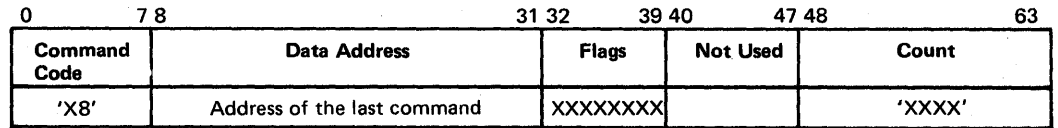

TIC*-8 branches back to the last command address.
 X = positions ignored.

Write Data

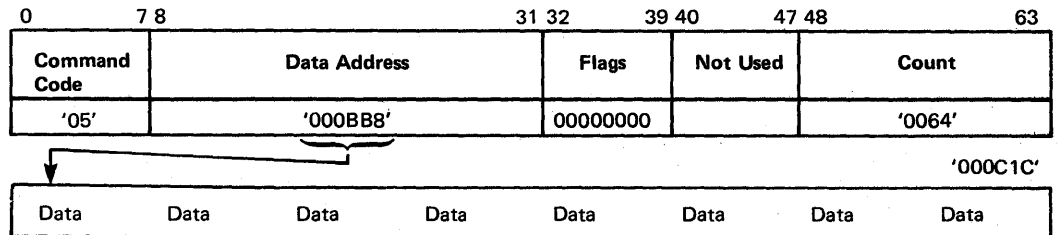

The Write Data command transfers the data to update Frank Smith's payroll record from main storage locations '0BB8' through '0C1C' to the disk.

If Frank Smith's payroll record is not at cylinder '0C', head '04', the program loops between the Search Key Equal and the TIC until every key on the track has been searched. The storage director then signals unit check to the channel. A subsequent Sense I/O command indicates no record found.

Update Write (Continued)

The data just written could be verified by chaining the following CCWs to the Write Data command:

Read Sector	Store sector address
Set Sector	Locate sector
Search Key Equal	Locate record
TIC*-8	
Read Data	Verify data

Read

Example: Find and read Joe Brown's insurance policy number. Assume that the 3330 disk is organized by ID (no keys). Joe Brown's employee number is 12341. The data length of each record is '00AA' (170₁₀) bytes. His policy number is in the data area.

Note: If 3340s or 3350s are attached, the only difference would be the figures taken from the record capacity chart. The procedure remains the same.

The 3330 record capacity chart shows that forty-three 170-byte records can be written on the track. Since the disk is organized by IDs (Joe Brown's = 12341), the track and record location can be found by dividing the ID by the number of records per track. In this case:

$$12341/43 = 287_{10} \text{ (add 1 to the remainder to establish the address)}$$

Thus, Joe Brown's ID is 287₁₀ tracks from the beginning of the data set. There is no remainder, so the first record on the track is Joe Brown's. The CC HH R for the Seek command is then determined by converting the 287₁₀ tracks to cylinders and adding the results to the beginning of the data set.

	Cylinder	Track	Record	C	C	H	H	R
Starting Address	10	00	0	00	0A	00	00	00
Displacement*	15	02	1	00	0F	00	02	01
Result	25	02	1	00	19	00	02	01

*Determined by dividing 287 by 19.

The channel program is:

```

Seek
Search ID Equal
TIC*-8
Read Data
    
```

Seek

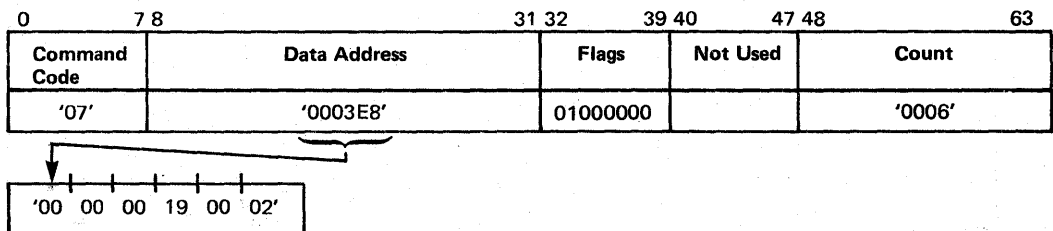

The Seek command is executed as explained in the Update Write example and moves the access mechanism cylinder '19' (25₁₀) and select head '02'.

Read (Continued)

Search ID Equal

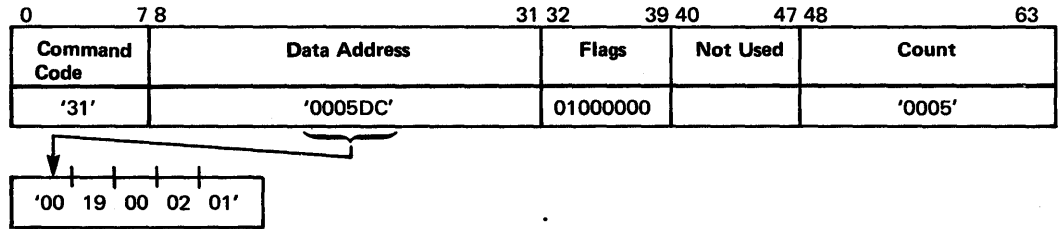

The Search ID Equal causes the first ID found on the track to be compared with Joe Brown's ID. All unequal comparisons of IDs cause the storage director to signal channel end and device end to the channel and the TIC (back to Search ID Equal) is executed. When an equal compare is found (ID of record 1), the storage director signals channel end, device end, and status modifier to the channel. Status modifier causes the next command (TIC) to be skipped and the Read Data command to be executed.

Transfer-In-Channel (TIC)

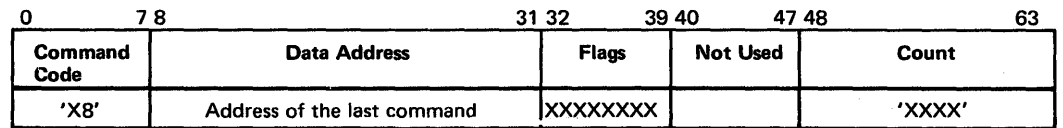

TIC*-8 branches back to the last command address.
X = positions ignored.

Read Data

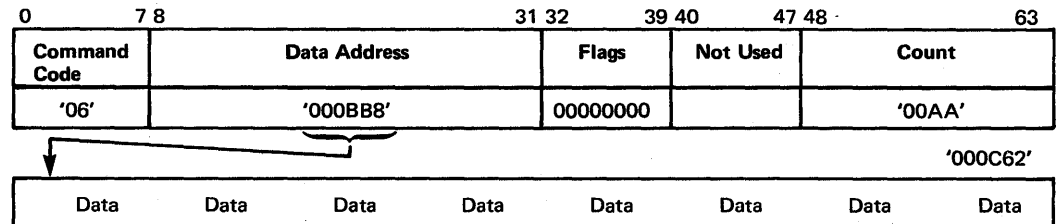

Execution of the Read Data command causes the data area containing Joe Brown's insurance policy number to be read into main storage at locations '0BB8' through '0C62'.

Standard and Special Features

This section of the manual describes the features available with the 3880 and its attached disk storage, and gives examples of how to use the features. The functions of the features as related to 3375 and 3380 operations will be provided in a later edition of this manual.

Multitrack

The multitrack feature is a standard feature that applies to all disk storage devices except the 3370. It is not required on devices that use fixed block formats.

On all search and most read commands, a storage director can automatically select the next sequentially numbered head on the disk drive under control of bit 0 of the command code. If bit 0 is a 1 and data transfer of the command has not been initiated, the next sequentially numbered head is selected at index. Thus, the need for Seek Head commands in a chain of read or search commands is eliminated.

Discretion must be used when using the multitrack bit. For example, assume that during a multitrack search operation the desired record is on the first track searched and the search begins after that record is passed. The head number, therefore, is advanced to the next track without comparing the key or ID of the desired record. Also, should a Set Sector command with a sector value of zero precede a multitrack command, head switching could occur before the desired record is reached. To avoid these conditions, a single-track Read Home Address or Read R0 command should be placed before the search command, thus ensuring that the search begins at R0 or R1 of the track. (See Figure 9 for an example of a multitrack operation.)

Multitrack operations are not used on Read IPL, Read Sector, or Read Multiple CKD commands.

Cylinder 02

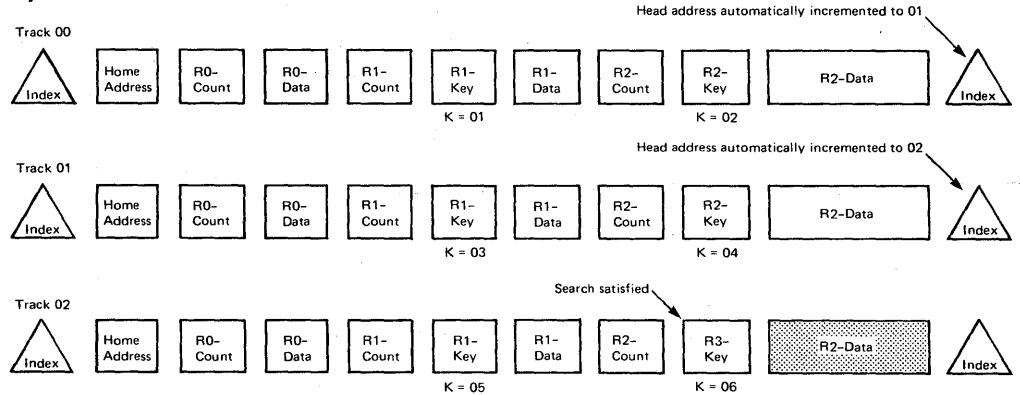

The disk is organized by keys, and the physical address of the record is unknown.

Channel Program:

Set File Mask (allow write and seek commands)
 Seek (cylinder 02, head 00)
 Read Home Address (make sure all records are read)
 Search Key Equal (multitrack bit on, argument = 06)
 TIC*-8
 Write Data (updates shaded area)

Figure 9. Multitrack

Record Overflow

The record overflow feature is a standard feature that applies to 3330, 3333, 3340, 3344, and 3350 disk storage devices. Record overflow provides a means of processing logical records that exceed the capacity of a track. When using overflow records, the cylinder boundary limits the size of the record.

Each part of an overflow record written on (or read from) one track is called a record segment. Each segment contains a count, key (optional), and data field.

Formatting Overflow Records

The Write Special CKD command is used to format all segments of an overflow record except the last segment. The key and data lengths specified in the KL and DL bytes of the count field of the command pertain only to that segment, not the entire overflow record. Except for the first overflow segment, the record number in the count fields of all the subsequent segments must be 1. Since only the key field of the first segment has significance, overflow records are usually formatted without key fields (KL = 0). As shown in Figure 10, the last segment is formatted with a normal Write CKD command.

When a Write Special CKD command is executed, a 1 is written in the flag byte bit position 4 of the record segment being written. This bit, which identifies the record as an overflow segment, indicates to subsequent record processing commands that the logical record continues on the following track.

No internally generated head switching is associated with formatting overflow records; all head seeking must be done by the formatting program (see Figure 10).

Except for the first, all record segments must be written immediately following R0, and all segments except the last must be the last physical record on their tracks.

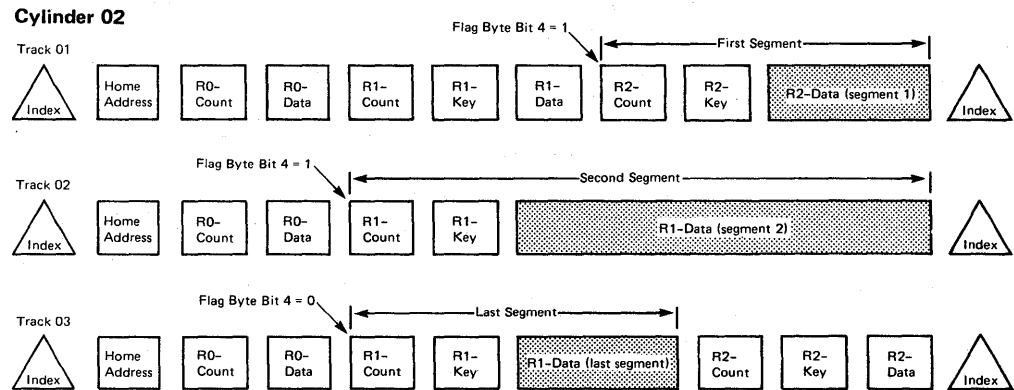

Typical channel programs for formatting, updating, and reading overflow records.

Formatting:	Updating:	Reading:
Set Sector	Set Sector	Set Sector
Search ID R1 (track 1)	Search ID R2 (segment 1)	Search ID R2 (segment 1)
TIC*-8	TIC*-8	TIC*-8
Write Special CKD (segment 1)	Write Data (updates shaded areas)	Read Data (reads shaded areas)
Seek Head (next track)		
Search ID R0 (track 2)		
TIC*-8		
Write Special CKD (segment 2)		
Seek Head (next track)		
Search ID R0 (track 3)		
TIC*-8		
Write CKD (last segment)		

Figure 10. Overflow Record

Processing Overflow Records

The following commands may be used to read or update previously formatted overflow records.

- Read Count, Key, and Data
- Read Key and Data
- Read Data
- Write Key and Data
- Write Data

When any of the above commands are used to process an overflow record, the operation does not terminate at the end of a record segment when the segment is flagged with bit 4 (on) in the flag byte. Instead, the head address is incremented by one at index and the operation continues in the data field of record 1 on the next track. If this record segment is also flagged with bit 4 (on) in the flag byte, the operation continues on the next track. When a segment is found that is not flagged, the operation terminates at the end of the data field. The net effect of this procedure is that the data fields of all the record segments appear as a single logical data field.

If a data overrun or data check occurs during the first segment, the storage director attempts recovery through use of command retry. If a data overrun occurs during an operation involving the second (or subsequent) segments, unit check is signaled immediately during a read operation, or at the end of the associated segment during write operations.

If a data check or bus out parity error occurs, unit check is signaled at the end of the associated area.

Note: *If a write operation was in progress, unit check is signaled at the end of the record segment.*

If the CCW count is less than the number of bytes in the logical record, the operation continues to the end of the logical record before presenting ending status.

Spacing over overflow records does not occur automatically. The channel program must be written so that the entire logical record is spaced over, not just the first segment. For example, in the sequence:

```
Set Sector
Search ID (first segment)
TIC*-8
Read CKD (multitrack)
```

the Read CKD command does *not* read the next logical record on the cylinder. It begins reading the overflow record at the count field of the second segment.

The sequence:

```
Set Sector
Search ID (first segment)
TIC*-8
Read Key and Data (skip and SLI flags on)
Read CKD (multitrack)
```

reads the count, key, and data fields of the next logical record.

Multitrack operations should not be confused with overflow record operations. Head switching, when processing overflow records, occurs regardless of whether the multitrack bit is on or off.

Processing Overflow Records (Continued)

Head switching does not occur:

- In violation of the file mask
- Past the end of the cylinder
- To a defective track
- To an alternate track

All segments of an overflow record, except the first, must be written immediately following record zero; all segments, except the last, must be the last physical record on their respective tracks.

End Of File

The end-of-file feature is a standard feature that applies to all disk storage devices except the 3370. It is not required on devices that use fixed block formats.

An end-of-file record, used to define the end of a logical group of records, is written by executing a Write CKD, Write Special CKD, or Write R0 command with the data length (DL) bytes in the count area set to zero. Execution of one of these commands with a data length of zero causes the storage director to write a data area consisting of one byte of zeros followed by the error correction code bytes (see Figure 11).

The key length (KL) portion of the count area can be either zero or non-zero. If KL equals zero, the end-of-file record contains only the contents of the count and data areas. If the key length is not zero, the key area is written as specified by the KL byte.

Detection of a zero data length causes unit exception status to be generated. No data from the data area is transferred to the channel. A Read R0, Read CKD, or Read Key and Data (KD) command transfers the key area (if any) to the channel.

The unit exception is generated during execution of Read IPL, Read R0, Read CKD, Read KD, Read Data, Write KD, and Write Data commands.

Cylinder 02

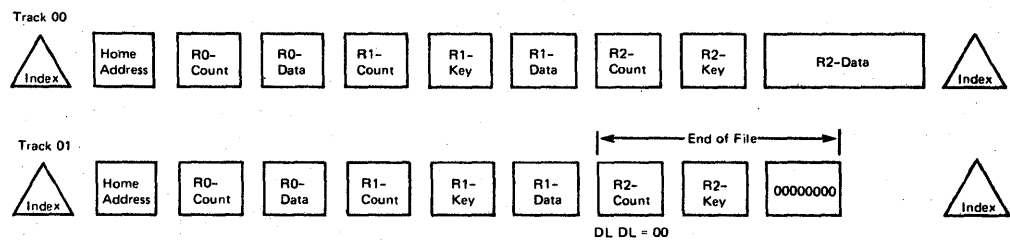

Channel Program:

Set File Mask (allow seek and write)
 Seek (cylinder 02, head 00)
 Write Home Address
 Write R0
 Write CKD R1
 Write CKD R2

Seek Head (cylinder 02, head 01)
 Write Home Address
 Write R0
 Write CKD R1
 Write CKD R2 (data length = 00)

Figure 11. End of File

Rotational Position Sensing

Rotational position sensing (RPS) is a standard feature that reduces the time required for the channel to search for a record. This feature lets a search command be started just before the required record comes under the read/write head.

Rotational position sensing is accomplished by dividing the storage disks into sectors. Each track in the cylinder is divided into 128 equally spaced sectors and each track record has a sector location as well as a record address. Although not physically indicated on the tracks, the sector location is stored at the beginning of all read, write, and search commands. When chained to a read, write, or search CCW, the Read Sector command provides the sector location required to access the record that was processed by the previous command. A later Set Sector command fetches the sector location from main storage and repositions the track at that record. This type of operation is particularly useful in write verification (see Figure 12) and sequential disk processing operations.

Note: When an end-of-file (EOF) mark is written, the DL in the count area must be zero. The storage director, however, adds a one byte data area when writing the EOF mark. Programmers working with track balance routines must allow for this byte by subtracting one byte from the track balance remaining. The standard 135-byte overhead allowance should, therefore, be increased to 136 for each EOF written.

The sector location of a record is determined by the length of all records that are ahead of it and its sequential position on the track. The sector location can be calculated with the following formulas.

3330 Series

$$S(n) = \frac{1}{105} \left[237 + \sum_{i=1}^{n-1} (KL_i + DL_i + C) \right]$$

Where:

$$\begin{aligned} C &= 135 \text{ if } KL_i = 0 \\ C &= 191 \text{ if } KL_i \neq 0 \end{aligned}$$

3340 Series Drives

$$S(n) = \frac{1}{140} \left[353 + \sum_{i=1}^{n-1} (KL_i + DL_i + C) \right]$$

Where:

$$\begin{aligned} C &= 167 \text{ if } KL_i = 0 \\ C &= 242 \text{ if } KL_i \neq 0 \end{aligned}$$

3350 Series Drives

$$S(n) = \frac{1}{156} \left[389 + \sum_{i=1}^{n-1} (KL_i + DL_i + C) \right]$$

Where:

$$\begin{aligned} C &= 185 \text{ if } KL_i = 0 \\ C &= 267 \text{ if } KL_i \neq 0 \end{aligned}$$

The following example shows some of the advantages of using rotational position sensing to locate and retrieve records.

3340 Without RPS

Channel program 1:

<i>Command</i>	<i>Channel and Storage Director Status</i>
Seek	Available as soon as the storage director accepts the seek address.

Channel program 2:

<i>Command</i>	<i>Channel and Storage Director Status</i>
Search ID Equal	Busy (average of ½ revolution or 10.2 ms on the 3340)
TIC*-8	
Read Data	Busy

3330, 3340/3344, or 3350 With RPS

When the sector address is known or can be calculated, the following channel program can be used.

Command	Block Multiplexer Channel and Storage Director Status
Seek	Available during access movement.
Set Sector	Available until sector is located.
Search ID Equal	Busy (average 250 μ s on the 3330).
TIC*-8	Normally the first ID read is that of the required record and the TIC is not executed.
Read Data	Busy.

Note that with RPS only one channel program is required to locate the record and transfer the data. This eliminates a seek I/O interrupt and the I/O processing required to schedule a data transfer channel program.

Also, the channel and disk storage are available during access motion and rotational positioning, allowing seek and set sector operations to be overlapped with other I/O operations on the storage director and channel.

Channel Program

Seek Selects the proper cylinder and head.

Search ID Equal (Rn) Reads the ID of each record.

TIC*-8 Branches back to the Search ID Equal command until Rn is located, then branches to the Write Data command.

Write Data Transfers the data from main storage and writes it in Rn.

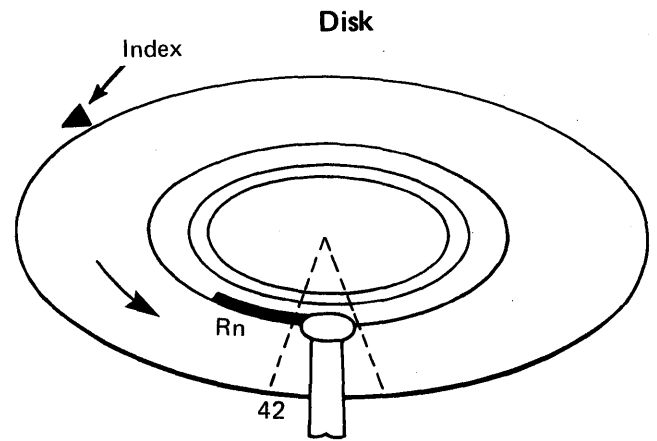

Read Sector Reads and stores the sector number of Rn (42).

Set Sector Transfers the sector number of Rn (42) to the storage director. The channel disconnects until the target sector is located. It is available for other operations during this period. If the channel is not available when the target sector is located on reconnection, the storage director waits and tries to reconnect on the next revolution.

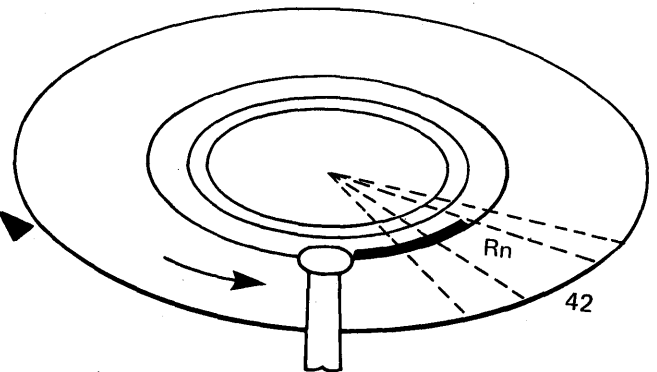

Search ID Equal (Rn) Reads the ID of each record.

TIC*-8 Branches back to the Search ID Equal command until Rn is located, then branches to the Read Data command.

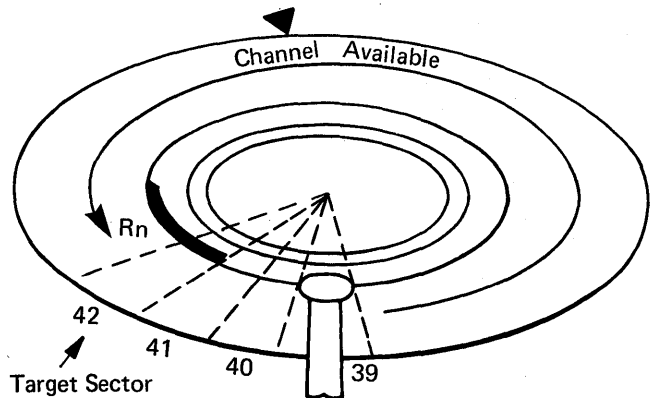

Read Data Transfers the data from record Rn to main storage where it is compared with the original data from the Write Data command.

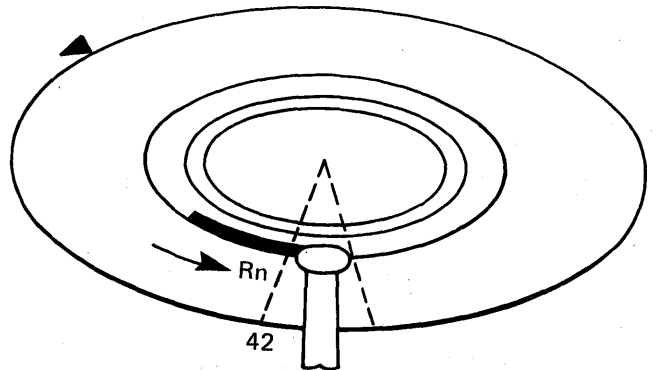

Figure 12. RPS for Write Verification

Command Retry

Command retry (a standard feature) is a combined channel and storage director procedure that causes an improperly executed command in a channel program to be automatically retried. Retry is requested when the storage director sends retry status (unit check with channel end and/or device end and status modifier) to the channel. Command retry procedures are device dependent and are not implemented in the same manner for all devices attached to the 3880. In some applications command retry is not performed but the retry status is used to orient the CCW address to the proper main storage location for the system error recovery procedures.

Command retry procedures that apply to 3330 and 3350 disk storage are described in the Command Retry – 3330 and 3350 section of this manual; command retry procedures for the 3370 are described in the Command Retry – 3370 section of this manual. Command retry is not used on 3340/3344 devices.

Channel Switching

Three channel-switch features are available with the 3880:

- The *two-channel switch pair* feature allows each storage director and its attached drives to be shared by two channels.
- The *two-channel switch pair, additional* feature allows each storage director and its attached drives to be shared by four channels. The two-channel switch pair feature is a prerequisite for this feature.
- The *eight-channel switch* feature allows both storage directors and their attached drives to be shared by eight channels. The same eight channels must be switched to both storage directors. (For the two-channel switch pair and the two-channel switch pair, additional features, different channels can be switched to each storage director.) The two-channel switch pair and the two-channel switch pair, additional features are prerequisites for this feature.

The channels may be attached to the same or different processing units and, with appropriate programming or operator action, individual drives may be reserved for the exclusive use of any of the channels.

Channel switching and device reservations are controlled by the channel program. Three special commands are associated with the channel switching features: Device Reserve, Device Release, and Unconditional Reserve.

Two Enable/Disable switches are added to the operator panel for the two-channel switch pair feature; four more are added for the two-channel switch pair, additional feature; and eight more are added for the eight-channel switch feature.

Channel Selection Switch

Channel selection is controlled by a switch in the storage director. When the switch is in the neutral position, the storage director can be selected by any channel.

Once a storage director has been selected by a channel, it is switched to that channel until the channel disconnects. The channel selection switch then returns to the neutral position unless:

- Chaining is indicated and device end is included in the status.
- Chaining is indicated without device end in the status, the channel disconnects, and the storage director becomes busy to allow execution of an ERP, Diagnostic Load command, Diagnostic Write command, or completion of a format-write operation.
- Chaining is indicated and a format-write operation is in progress.
- The last status byte was part of a channel initiated signal sequence and was stacked by the channel.
- A contingent connection is established.
- Ending status associated with an interface disconnect has not been accepted by the channel.

Device Status

Device status is generated for, and presented to, each enabled channel. The channel must accept the device status before using the associated device.

Remote Switching

The remote switch features are special features that remove the Enable/Disable switches from the 3880 operator panel and relocate them to a remote location. This allows an operator to reconfigure the system from a central point.

- The *remote switch* feature is used when attaching to a single channel and in conjunction with the two-channel switch pair feature.
- The *remote switch additional* feature is used in conjunction with the two-channel switch pair, additional feature.
- The *remote switch for eight-channel switch* is used in conjunction with the eight-channel switch feature.

Statistical Usage and/or Error Recording

Each storage director maintains a statistical data record of usage and error information for each attached logical device. The usage information provides an accumulated count of the number of access motions and the total number of bytes read or searched for each device. The error information includes the number of command and data overruns that occurred. This information is maintained for each channel that has access to the drive.

For 3370 devices, the usage information also includes an accumulated count of the number of access movements, data blocks read, and data blocks written with write verify specified. The error information also provides the total number of seek errors, correctable data errors, and uncorrectable data errors.

Usage and error information are offloaded to the system when the counters reach a predetermined level or when a Read and Reset Buffered Log command is executed.

Statistical usage and/or error recording is a standard feature.

Error Detection and Logging

Failures that occur during execution of channel commands are indicated in unit status. Other failures are presented to the system through the alternate storage director or cause a channel check. If one of the storage directors in the 3880 fails, error sense information related to the failing storage director is transferred to the system through the other storage director.

All error conditions and sense information presented to the system by the 3880 are saved in the operating system error log. The error recovery procedures format, summarize, and print the system recorded error information.

Block Multiplexing

Block multiplexing is a standard feature that allows a storage director to disconnect from the channel during mechanical delays caused by commands that require repositioning of the access mechanism or excessive rotational delay.

During execution of Seek, Set Sector, Locate, and Diagnostic Control commands, the storage director is allowed to disconnect from the channel between channel end and device end status. The channel attempts to reconnect when the access motion is completed and/or the desired rotational position is detected.

During the time that the storage director is disconnected from the channel, the processing unit is free to initiate I/O operations on other devices attached to the storage director even though the disconnected channel program is not complete. This allows separate channel programs to operate simultaneously on each drive attached to the storage director.

Error Recovery Procedures

The error recovery procedures contain an error condition table and a recovery action table for each type of device that attaches to the 3880. The error condition table identifies all unique configurations of the sense bits in sense bytes 0, 1, and 2. Each configuration has a specific recovery action that is invoked by the system. The recovery action table specifies the action to be taken for each error condition. The recovery action and error condition tables for each device are located after the sense byte descriptions for the device. (The 3330 and 3350 recovery action and error condition tables are combined and are located after the 3350 sense byte descriptions.)

Sense information, the recovery action table, and other error recovery procedures for the 3375 and 3380 will be provided in a later edition of this manual.

Console Error Message

The console error message should be printed for all permanent errors and should contain the:

- Message code
- Error type (read, write, or control)
- Module designation (drive address), cylinder number, and head number (seek address)
- Channel designation
- Status and sense bytes sent to the processor

Error Correction Function – Fixed Block Devices

The device recovery action tables use the error correction function as a step in recovering correctable data errors that may occur in the data area of a record.

When the correctable and data check sense bits are posted in the sense information, sense bytes 18 through 23 provide error pattern and displacement information. Error correction is accomplished by aligning the error pattern in sense bytes 20 through 23 with the erroneous data in main storage and exclusive ORing the data.

The location of the erroneous data in main storage is determined by the displacement information in sense bytes 18 and 19, and by the counts provided in the interrupted CCW chain. The storage director specifies the location of the error bytes relative to the first byte transferred in the operation. The displacement between the first byte transferred and the first byte in error is calculated by multiplying the number of blocks transferred (sense bytes 16 and 17) by 512 to obtain the restart displacement and subtracting the error displacement provided in sense bytes 18 and 19. The result is the forward error displacement which is used, in conjunction with the count specified in the interrupted CCW, to locate the erroneous data in main storage.

If data chaining was indicated in the operation that posted the correctable error, the forward displacement may reference data from the second (or subsequent) CCW in the chain. The storage director automatically ensures that the CSW points to the interrupted CCW + 8.

The error correction function is bypassed for bytes that were not transferred to main storage because the skip bit was on or there was a short CCW count.

If the indirect address bit is on during the operation that posted the correctable error, the first data address is obtained from the first indirect address word (IDAW). The CCW data address points to the IDAW, and correction proceeds as described for data chaining.

Error Correction Function – Fixed Block Devices (Continued)

Example

In this example the CSW-8 points to CCW 2 in the following chain:

CCW	Command	Address	Count	Flags
1	Locate	A	8	Command chaining
2	Read	B	1024	Data chaining
3	TIC	CCW 4	—	—
4	Read	D	6	Suppress incorrect length

The error affects bytes 6 and 7 of the first block of data transferred by CCW 4 as follows:

Byte 6 — — — — — X X

Byte 7 X — — — — —

Where (—) corresponds to a correct bit
(X) corresponds to an incorrect bit

The illustrated condition generates the following error correction information:

Sense bytes 16 and 17 = 3 (block count)

Sense bytes 18 and 19 = 507 (error displacement)

Sense bytes 20 and 21 = 0000 0011 and 1000 0000 (error pattern)

Application of the error correction function, as outlined in the preceding sections, results in the following system recovery action.

1. Pattern byte 1 is exclusively ORed with main storage location D + 5.
2. Pattern byte 2 does not apply to data byte 7 of the third block because of the short count in CCW 4.

Restart CCWs – Fixed Block Devices

If operation incomplete (byte 1, bit 7) is set in the sense information, it indicates that an error or unusual condition occurred during a logical operation after data transfer had been initiated. By constructing restart CCWs, the error recovery procedures are able to correct the unusual condition and continue the current operation from the point of interruption to the normal ending point.

Restart CCW 1

Construct restart CCW 1 as follows:

1. If sense byte 8, bit 7 equals 0, set the restart command code to '42'; otherwise, set it to '41'.
2. Use the data address of the interrupted CCW, plus the count of that CCW, minus the residual count in the channel status word.
3. Use the flags (except PCI) of the interrupted CCW.
4. Use the residual count in the CSW for the count. If the residual count is zero, a count of one must be used.

If a write command was in progress, the data address must specify a byte containing '00'. If a read command was in progress, the skip bit must be on.

Restart CCWs – Fixed Block Devices (Continued)

Restart CCW 2

Construct restart CCW 2 as follows:

1. If sense byte 8, bit 7 equals 0, set the restart command code to '42'; otherwise, set it to '41'.
2. Construct the count.
 - a. Fetch the byte count of the CCW designated by CSW-8, designate it COUNT, and set a pointer to it.
 - b. Set T equal to the number of blocks derived from COUNT. Set N equal to the number of blocks transferred as indicated in bytes 16 and 17. If $T - N > 0$, go to step f; otherwise, go to step c.
 - c. Check the chain data flag of the CCW designated by the pointer. If the flag is off (truncation occurred), go to step e; otherwise, go to step d.
 - d. Advance the pointer to the next non-TIC CCW in the data chain and add the count of this CCW to the counts of all preceding non-TIC CCWs in the data chain. Return to step b.
 - e. Set the restart CCW 2 count equal to 1. Go to step 3.
 - f. Set the restart CCW 2 count equal to $COUNT - N \times 512$. Go to step 3.
3. Use the flags (except PCI) of the CCW designated by the pointer in step 2. Set the skip bit if step 2e was executed and the operation was a read.
4. Use the data address of the CCW designated by the pointer in step 2, plus the count of that CCW, minus the restart CCW count constructed in step 2. If step 2e was executed and the interrupted operation was a write, the data address must specify a byte containing '00'.

If another operation incomplete occurs while executing the restart CCW, a new restart CCW may be generated from the old restart CCW. Do not destroy the old restart CCW before attempting to construct the new one.

Error Correction Function – Count, Key, and Data Devices

The following description of the error correction function applies to 3330, 3333, 3340, 3344, and 3350 disk storage.

The recovery action tables use an error correction function as a step in recovering from data errors. The error correction function is used when the storage director posts the data check and correctable sense bits in the sense information. These bits are posted if a correctable data error is detected in any data area.

Correctable data errors in home address, count, and key areas on 3330s and 3333s are corrected internally by the storage director using command retry. Data check and correctable sense bits are not posted for these errors and do not cause a system interrupt.

When the correctable and data check sense bits are included in the sense information, sense bytes 18 through 22 provide the error pattern and displacement. Error correction is accomplished by aligning the error pattern provided in sense bytes 20 through 22 with the erroneous data in main storage and exclusively ORing the error pattern and main storage bytes.

Error Correction Function – Count, Key, and Data (Continued)

The location of the erroneous data in main storage is determined by using displacement information provided in the sense bytes and the counts provided in the interrupted CCW chain. The storage director specifies the location of the error bytes, relative to the first byte transferred in the operation that incurred the error. The displacement between the first byte transferred and the first byte in error is calculated by subtracting the error displacement provided in sense bytes 18 and 19 from the restart displacement provided in sense bytes 15 through 17. The result constitutes the forward error displacement and is used, in conjunction with the count specified in the interrupt CCW, to locate the erroneous main storage data.

If data chaining was indicated in the operation that posted the correctable error, the forward displacement may reference data from the second (or subsequent) CCW in the data chain.

If the indirect address bit is on during the operation that posted the correctable error, the first data address is obtained from the first indirect address word (IDAW). The CCW data address points to the IDAW, and correction proceeds as described for data chaining.

Before applying the error correction function, determine whether any error bytes were not transferred because the skip bit was on, there was a short count in the CCW, or if the error bytes are not in adjacent main storage locations because of data chaining between CCWs.

- If any of the error bytes are in data specified by a CCW with the skip bit on, the error correction function cannot be used for the bytes that were not transferred to main storage.
- If any of the error bytes are in data not transferred to main storage because of a short CCW count, the error correction function cannot be used for the bytes that were not transferred to main storage.
- If no short CCW count is found and bit 7 of sense byte 23 indicates that a channel truncation occurred, the error correction function cannot be applied correctly.
- If the error pattern covers non-adjacent main storage boundaries because of data chaining, the error correction function must be selectively applied to the separate storage locations.
- If the error displacement in sense bytes 18 and 19 is less than 3, the error is partially or totally contained in the correction code bytes. The error pattern in sense bytes 20 through 22 is then constructed as follows:
 1. If the error displacement is zero, or if the error is totally contained in the gap that immediately precedes the data area, the error pattern must be set to zero by the error recovery procedures.
 2. If the error displacement is one, the two low-order error pattern bytes (bytes 21 and 22) must be set to zero by the error recovery procedures. The high-order bytes contain the correction syndrome.
 3. If the error displacement is two, the low-order pattern byte must be set to zero by the error recovery procedures. The high-order bytes contain the correction syndrome.

Example

In this example the key length is 2 and the data length is 10.

The CSW-8 points to CCW 1 in the following chain:

CCW	Command	Address	Count	Flags
1	Read Key and Data	A	2	Data chaining
2	TIC	CCW 3	—	—
3	—	B	4	Data chaining, skip
4	—	C	1	Suppress incorrect length

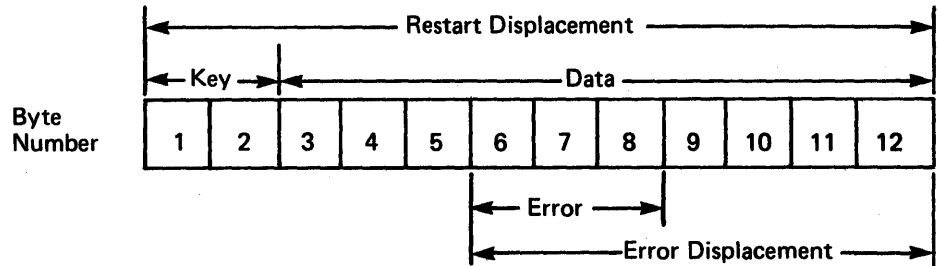

The error affects bytes 6, 7, and 8 as follows:

```

Byte 6  - - - - - X X
Byte 7  X X X - - - -
Byte 8  X - - - - -
  
```

Where (—) corresponds to a correct bit
 (X) corresponds to an incorrect bit

The illustrated condition generates a restart displacement of 12 and an error displacement of 7. The following error pattern is produced.

```

Pattern byte 1 (sense byte 20)  0 0 0 0 0 0 1 1
Pattern byte 2 (sense byte 21)  1 1 1 0 0 0 0 0
Pattern byte 3 (sense byte 22)  1 0 0 0 0 0 0 0
  
```

Application of the error correction function, as outlined in the preceding sections, results in the following system recovery action.

1. Pattern byte 1 does not apply to data byte 6, since this byte is not transferred to main storage due to the skip flag in CCW 3.
2. Pattern byte 2 is exclusively ORed to main storage location B, where data byte 7 resides.
3. Pattern byte 3 does not apply to data byte 8, since this byte is not transferred to main storage due to a short count in CCW 4.

Restart CCWs – Count, Key, and Data Devices

If operation incomplete (byte 1, bit 7) is set in the sense information, it indicates that an error or unusual condition occurred during a logical operation after data transfer had been initiated. By constructing restart CCWs, the error recovery procedures are able to correct the unusual condition and continue the current operation from the point of interruption to the normal ending point.

The recovery action table specifies the restart CCW required, either 1 or 2.

Restart CCW 1

Construct restart CCW 1 as follows:

1. Use the command code byte provided in sense byte 3.
2. Use the data address of the interrupt CCW, plus the count of that CCW, minus the residual count in the channel status word.
3. Use the flags (except PCI) of the interrupted CCW.
4. Use the residual count in the CSW for the count. If the residual count is zero, a count of one must be used.

If a write command was in progress, the data address must specify a byte containing '00'. If a read command was in progress, the skip bit must be on.

Restart CCW 2

Construct restart CCW 2 as follows:

1. Use the command code provided in sense byte 3.
2. Construct the count as follows:
 - a. Fetch the count of the CCW designated by CSW-8, and set a pointer to this CCW.
 - b. Subtract the restart displacement from the count obtained in step a. If this result is positive, go to step f; otherwise, go to step c.
 - c. Check the chain data flag of the CCW designated by the pointer. If the flag is not set (truncation occurred), go to step e; otherwise, go to step d.
 - d. Advance the pointer to the next non-TIC CCW in the data chain and add the count of this CCW to the counts of all preceding non-TIC CCWs in the data chain. Return to step b.
 - e. Set the restart CCW 2 count to 1. Go to step 3 and include the skip bit in the restart CCW flags.
 - f. Set restart CCW 2 count equal to the result of the subtraction in step b. Go to step 3.
3. Use the flags (except PCI) of the CCW designated by the pointer in step 2. Set the skip bit if step 2e was executed.
4. Use the data address of the CCW designated by the pointer in step 2, plus the count of that CCW, minus the restart CCW count generated in step 2.

If another operation incomplete or an error in a Read Multiple CKD command occurs while executing the restart CCW, a new restart CCW may be generated from the old restart CCW. Return to step 2d, but do not destroy the old restart CCW before generating the new one.

Command Retry – 3370

Command retry is used to recover from the following error conditions.

- When a correctable data error occurs in the data area of a record, command retry is used to orient the system error recovery procedures to the initial CCW of the chain in which the error occurred. The data error is corrected through use of the sense information, and the chain is restarted under control of the error recovery procedures.
- When an uncorrectable data error occurs in the first block during a read operation, the command is retried until the error is corrected, or until it is determined that the error cannot be corrected.
- When an uncorrectable data error is detected in any other block, command retry is used to cause the system error recovery procedures to construct a restart CCW chain which begins reading from the block that was in error.
- When a seek error is detected or seek incomplete is signaled in the sense information, the storage director retries the seek until the access mechanism is positioned correctly or until it is determined that the error is permanent. If the error is permanent, the sense information indicates a permanent seek error.
- When a command overrun occurs, the storage director establishes reorientation and retries the command.
- When a service overrun occurs in the first block during a read or write data operation or in any block during a write and check data operation, the storage director retries the operation until it recovers from the error condition or it determines that the error is permanent.

If the error is permanent, the sense information indicates an overrun and a permanent error. If a service overrun occurs in the data area of any block except the first during a read- or write-without-check data operation, command retry is used to orient the error recovery procedures to the correct CCW and the system error recovery procedures are used to restart the command chain.

Internal Retry

Internal retry is a storage director procedure that causes some operations to be retried without an I/O interrupt or channel assistance.

Internal retry is used for the following conditions:

- When a defective or alternate block is detected during a read or write operation, the storage director accesses to the correct position and continues the operation in progress.
- If an error is detected in the block ID field, the storage director reorients to the failing block and repeats the operation until the error is corrected.

If the error cannot be corrected, sense information indicates data check, permanent error, and uncorrectable block ID.

- When a seek error is detected during execution of a format defective block, check data, or format block ID operation, the storage director repositions the access mechanism to the desired track and retries the seek until the error is corrected, or until it is determined that the error cannot be corrected. If the error cannot be corrected, the sense information indicates equipment check, permanent error, and seek check. The storage director attempts to recover from the error by using the system error recovery procedures.

Command Retry – 3330 and 3350

Command retry is used to recover from the following error conditions.

- When a correctable data error occurs during a read or search operation on a home address, count, or key area on 3330 devices.
- When a correctable data error occurs in the data area of a record on a 3330 or 3350, command retry is used to orient the system error recovery procedures to the initial CCW of the chain in which the error occurred. The data error is corrected by use of the sense information and the chain is restarted under control of the error recovery procedures.
- When an uncorrectable data error is detected in any field during a read or search operation, the command is retried until the error is corrected or until it is determined that the error cannot be corrected.
- When a defective or alternate track is detected before data transfer has started, the storage director initiates a seek to the appropriate track, orients on index, and reissues the command.
- When a seek error is detected or seek incomplete is signaled in the sense information, the storage director retries the seek until the access mechanism is positioned correctly, or until it is determined that the error is permanent. If the error is permanent, the sense information indicates equipment check, permanent error, and seek check.
- When a command overrun occurs, the storage director initiates a retry of the last command.
- When a data overrun occurs, the command is retried (unless the data overrun occurred during the second or subsequent segment of an overflow record, during a format write operation, or during a Read Multiple CKD command).
- When command retry is used to allow the channel to disconnect during some padding operations, and to reconnect upon completion of padding.
- When command retry is used to initiate a seek operation previously received from the channel but not initiated by the device. When the required Set Sector, Space Count, Write Home Address, read, or search command is received, the storage director disconnects from the channel, seeks to the specified track, and reissues the command.

Execution of command retry may cause the following conditions to be detected by the initiating program:

- A CCW containing a PCI may, if retried because of command retry, cause multiple PCI interruptions to occur.
- A channel program consisting of a single, unchained CCW specifying an immediate command may cause a condition code of 0 rather than 1 to be set. This condition code is set if the storage director signals command retry at the time initial status is presented to the channel. The channel program then causes a later interruption upon completion of the operation.
- If a channel program stops prematurely during a command retry, the residual count and command address field in the CSW may not necessarily indicate the extent of main storage used.
- If a CCW used in an operation is changed before that operation has been successfully completed, the results are unpredictable.

Sense Bytes - 3370

Sense information for the 3370 (24 bytes) identifies the conditions that caused the last unit check status to be generated. The sense information also provides secondary information for system error recovery and for diagnosing and isolating storage director and device malfunctions.

Sense Byte 0

Bit 0
Command Reject

Bit 0 is set by:

- An invalid command code
- An invalid command sequence
- An invalid or incomplete argument transferred by a control command
- Issuing a format write command with the Write Inhibit switch in the Read-Only position
- Issuing a format write command that violates the define extent mask
- Issuing a Locate command with a format defective block specified in the operation byte, and space in the alternate area has been exhausted. Byte 1, bit 7 (operation incomplete) is also set
- Issuing a Locate command with write data specified in the operation byte and the define extent mask inhibits all write operations
- An invalid or incomplete argument transferred by a Diagnostic Control command

Bit 1
Intervention Required

Bit 1 is set by:

- Addressing a drive that is not attached to the system
- Addressing a drive that is not ready.

Bit 2
Bus Out Parity

Bit 2 is set when a parity error is detected during the transfer of a command from the channel to the 3880.

Bit 3
Equipment Check

Bit 3 is set when an unusual hardware condition occurs in the channel, storage director, or drive. The condition is further defined in sense bytes 7 through 23.

Bit 4
Data Check

Bit 4 is set when the storage director detects a data error in the information received from the drive. If byte 2, bit 1 (correctable) is also set, the data error is correctable and bytes 16 through 23 provide correction information. If the data error is uncorrectable, sense byte 7 defines the specific nature of the condition.

Bit 5
Overrun

Bit 5 is set when the storage director does not receive a response to a data request within a specified period of time. Detection of an overrun terminates data transmission. When writing, the remaining portion of the record area is padded with zeros. Byte 1, bit 7 (operation incomplete) is also set.

Bit 6

Bit 6 is not used. It is set to zero.

Bit 7

Bit 7 is not used. It is set to zero.

Sense Byte 1

- Bit 0**
Permanent Error
- Bit 0 is set when internal error recovery has been exhausted (through the use of command retry) and was unsuccessful, or when internal error recovery was not possible or desirable. The bit overrides any other bit settings and indicates that system error recovery procedures may not be required.
- Bit 1**
Block Size Exception
- Bit 1 is set when an invalid block size is specified in bytes 2 and 3 of a Define Extent command.
- Bit 2**
- Bit 2 is not used. It is set to zero.
- Bit 3**
Operator Message
- Bit 3 is set in conjunction with byte 0, bit 3 (equipment check) to indicate a permanent failure in the alternate storage director or a state save operation in the reporting storage director.
- Bit 4**
- Bit 4 is not used. It is set to zero.
- Bit 5**
File Protected
- Bit 5 is set when a Diagnostic Control or Locate command violates the logical extent limits established by a Define Extent command.
- Bit 6**
Write Inhibited
- Bit 6 is set when a write operation is attempted on a drive that has its Write Inhibit switch in the Read-Only position. Byte 0, bit 0 (command reject) is also set.
- Bit 7**
Operation Incomplete
- Bit 7 is set when:
- A correctable data check is detected in the data area of any block other than the last block. Byte 0, bit 4 (data check) and byte 2, bit 1 (correctable) are also set.
 - An uncorrectable data check is detected in the data area of any block other than the first block. Byte 0, bit 4 (data check) is also set.
 - A service overrun is detected in a data area of any block other than the first during a read or update-write operation. Byte 0, bit 5 (overrun) is also set.
 - A Locate command has been issued with a format defective block specified in the operation byte, and space in the alternate area is exhausted. Byte 0, bit 0 (command reject) is also set.
 - A seek error is detected after the start of data transfer during a multitrack read or write operation.

Sense Byte 2

Bit 0 Check Data Error	Bit 0 is set when an uncorrectable data check is detected during the read-back verification phase of a Write command with write and check data specified in the preceding Locate command.
Bit 1 Correctable	Bit 1 is set when the data check condition indicated by byte 0, bit 4 (data check) is correctable.
Bit 2	Bit 2 is not used. It is set to zero.
Bit 3 Environmental Data Present	Bit 3 is set when: <ul style="list-style-type: none">• An error counter overflows.• The usage statistics require off-loading.• A Read and Reset Buffered Log command is executed.
Bit 4	Bit 4 is not used. It is set to zero.
Bit 5	Bit 5 is not used. It is set to zero.
Bit 6	Bit 6 is not used. It is set to zero.
Bit 7	Bit 7 is not used. It is set to zero.

Sense Byte 3

Bits 0 Through 7
Cylinder High Bits 0 through 7 identify the high-order cylinder address of the most recent seek.

Sense Byte 4

Bits 0 Through 7
Cylinder Low Bits 0 through 7 identify the low-order cylinder address of the most recent seek.

Sense Byte 5

Bits 0 Through 7
Head Address, IAR, or
Diskette Checks Bits 0 through 7 identify either:

- The head address of the most recent seek. (Operations involving head switching update this byte.)
- The high-order byte of the instruction address register (IAR) (when microcode detected format 3 is indicated).

In conjunction with sense format 6, byte 5 indicates the number of diskette checks after an initial microcode load (IML) or a storage director-to-storage director communication failure.

Bit 0 = Communication failure during an IML Bits 2–4 = Diskette check (seek errors)
Bit 1 = Not used Bits 5–7 = Diskette check (read errors)

Sense Byte 6

Bits 0 Through 7
Block Number, IAR, or
Storage Director ID Bits 0 through 7 identify the block that was last processed. This byte is valid only when byte 7, bits 0 through 3 specify format 4, format 5, or format 0 when byte 1, bit 7 (operation incomplete) is set. For microcode detected format 3, byte 6 contains the low-order byte of the IAR. For format 6, byte 6 identifies the storage director.

Sense Byte 7

Bits 0 Through 3 Format

Bits 0 through 3 specify the format of sense bytes 8 through 23 as follows:

- 0000 = Format 0 – program or system check
- 0001 = Format 1 – device equipment check (CE information)
- 0010 = Format 2 – storage director equipment check (CE information)
- 0011 = Format 3 – storage director control checks (CE information)
- 0100 = Format 4 – data check without displacement information (uncorrectable data checks)
- 0101 = Format 5 – data check with displacement information (correctable data checks)
- 0110 = Format 6 – usage statistics/overrun errors

Bits 4 Through 7 Message Code

Bits 4 through 7 describe the specific nature of the error conditions for each of the above formats. The message table that accompanies the format descriptions specifies the function of the message bits for the format.

Format 0 – Program or System Check

Format 0 is used when sense bytes 0 through 7 completely describe an error or unusual condition caused by a program or system error.

Bytes 8 Through 15 Locate Parameters

When byte 1, bit 7 (operation incomplete) is set and the error was not detected on a Diagnostic Sense command, bytes 8 through 15 contain the updated Locate parameters. Otherwise, these bytes are set to zero.

Bytes 16 and 17 Number of Blocks Transferred

When byte 1, bit 7 (operation incomplete) is set and the error was not detected on a Diagnostic Sense command, bytes 16 and 17 contain the number of blocks transferred to the system (excluding the error block). Otherwise, these bytes are set to zero.

Bytes 18 Through 20

Bytes 18 through 20 are not used. They are set to zero.

Byte 21

Storage director ID.

Bytes 22 and 23

Symptom code.

Message Table – Format 0

Sense Byte 7, Bits 4-7 =	Message Code	Message
0000	0	No message. No additional information required.
0001	1	The storage director received an invalid command.
0010	2	The storage director received an invalid sequence of commands.
0011	3	The count specified in the CCW was less than required.
0100	4	The data argument of the command was invalid.
0101	5	A Diagnostic Control command was issued when prohibited by the Define Extent mask.
0110	6	The channel did not indicate chaining when retry status was presented.
0111	7	The command portion of the CCW that was returned after a command retry sequence did not match the command for which retry was signaled.
1000-1011	8-B	Reserved
1100	C	A Locate command with a format defective block specified in the operation byte was issued when the alternate space was exhausted.
1101	D	A service overrun occurred in the data area.
1110-1111	E-F	Reserved

Format 1 – Device Equipment Check

Format 1 is generated when:

- A device, device interface, or a controller equipment check is detected. Byte 0, bit 3 (equipment check) is also set.
- A permanent device seek check is detected. Byte 0, bit 3 (equipment check) and byte 1, bit 0 (permanent error) are also set.
- Error log information is off-loaded after a successful retried seek that occurred during error logging. Byte 3, bit 2 (environmental data present) is also set. The message bits in sense byte 7 indicate a seek error.
- Byte 11, bit 4 (on line) is off. Byte 0, bit 1 is also set.

Byte 8 CTL-I Tag Bus

Byte 8 contains the CTL-I tag bus value. This byte is not valid if it is zero. For message code A and if byte 11, bit 2 (drive check) is 0, byte 8 contains the high-order physical cylinder address of the track selected.

Byte 9 CTL-I Bus Out

For message codes 2, 4, B, C, D, E, and F, byte 9 identifies the contents of the CTL-I bus out. For message codes 1, 3, 5, 6, 7, 8, and 9, byte 9 contains the expected drive status or data. For message code A and if byte 11, bit 2 (drive check) is 0, byte 9 contains the low-order physical cylinder address of the track selected.

Byte 10 CTL-I Bus In

Byte 10 contains the CTL-I bus in value. This byte is not valid if it is zero. For message code A and if byte 11, bit 2 (drive check) is 0, byte 10 contains the physical head address of the track selected.

Byte 11 Drive Status

Bit 0 = Controller check
Bit 1 = Device interface check
Bit 2 = Drive check
Bit 3 = R/W check

Bit 4 = On line
Bit 5 = HDA attention
Bit 6 = Busy – not sector compare
Bit 7 = Seek or offset complete or search sector

Byte 12

Bits 0-5 = Not used
Bit 6 = Device bus out parity check
Bit 7 = Device tag bus parity check

Byte 13

When byte 11, bit 0 is off:
Bit 0 = Write mode check
Bit 1 = Capable/enable check
Bit 2 = Write overrun
Bit 3 = Index check
Bit 4 = Control check
Bit 5 = Select error
Bit 6 = HDA write check
Bit 7 = Decode check

When byte 11, bit 0 is on:
Bit 0 = Drive selected 0
Bit 1 = Drive selected 1
Bit 2 = Drive selected 2
Bit 3 = Drive selected 3
Bit 4 = Drive selected 4
Bit 5 = Drive selected 5
Bit 6 = Drive selected 6
Bit 7 = Drive selected 7

Format 1 (Continued)

Byte 14

When byte 11, bit 0 is off:

- Bit 0 = Write inhibit
- Bit 1 = Not used
- Bit 2 = Sector compare check
- Bit 3 = Write select verify
- Bit 4 = Write op OK
- Bit 5 = No select error
- Bit 6 = HDA read check
- Bit 7 = Transition detect check

When byte 11, bit 0 is on:

- Bit 0 = Not used
- Bit 1 = Not used
- Bit 2 = Not used
- Bit 3 = Not used
- Bit 4 = Microcontroller check 1
- Bit 5 = Microcontroller check 2
- Bit 6 = CS address parity check
- Bit 7 = PROM store check

Byte 15

When byte 11, bit 0 is off:

- Bit 0 = HDA sequence latch 0
- Bit 1 = HDA sequence latch 1
- Bit 2 = HDA sequence latch 2
- Bit 3 = CE drive motor switch on
- Bit 4 = Selected P11 good
- Bit 5 = Dc voltage good
- Bit 6 = Air system good
- Bit 7 = Unselected P11 good

When byte 11, bit 0 is on:

- Bit 0 = CTL-I bus out parity check
- Bit 1 = CTL-I tag bus parity check
- Bit 2 = Funnel 0/1 parity check
- Bit 3 = Not used
- Bit 4 = Device bus in parity check
- Bit 5 = Selected interface (0 = A, 1 = B)
- Bit 6 = Transfer check
- Bit 7 = MD bus in parity check

Byte 16

When byte 11, bit 0 is off:

- Bit 0 = Access timeout
- Bit 1 = Overshoot check
- Bit 2 = Servo off track
- Bit 3 = Invalid location
- Bit 4 = Sequence latch 1
- Bit 5 = Sequence latch 2
- Bit 6 = Sequence latch 3
- Bit 7 = Sequence latch 4

When byte 11, bit 0 is on:

- Bit 0 = Control register 3, 4, or 5 parity check
- Bit 1 = Not used
- Bit 2 = Any FCI register parity check
- Bit 3 = Buffer or control register 16 or 17 parity check
- Bit 4 = Not used
- Bit 5 = Error alert
- Bit 6 = Not used
- Bit 7 = Forced error alert

Byte 17

When byte 11, bit 0 is off:

- Bit 0 = Guardband latch
- Bit 1 = Guardband 2 ID
- Bit 2 = Track crossing
- Bit 3 = Velocity polarity latch
- Bit 4 = Even track
- Bit 5 = Fine track
- Bit 6 = End accelerate
- Bit 7 = End decelerate

When byte 11, bit 0 is on:

- Bit 0 = SERDES data funnel parity check
- Bit 1 = Counter parity check
- Bit 2 = ECC hardware check
- Bit 3 = VFO not in sync
- Bit 4 = Shift register parity check
- Bit 5 = SERDES data parity check
- Bit 6 = Write data check
- Bit 7 = Sync-out timing error

Format 1 (Continued)

Byte 18

When byte 11, bit 0 is off:

Bit 0 = Direction bit
Bit 1 = Difference count 512
Bit 2 = Difference count 256
Bit 3 = Calibrate 0
Bit 4 = Calibrate 1
Bit 5 = Calibrate 2
Bit 6 = Calibrate 3
Bit 7 = Calibrate 4

When byte 11, bit 0 is on:

Bit 0 = Device selection error
Bit 1 = Microcode detected error
Bit 2 = Not used
Bit 3 = Not used
Bit 4 = Not used
Bit 5 = Not used
Bit 6 = Not used
Bit 7 = Not used

Byte 19

When byte 11, bit 0 is off:

Bit 0 = Difference/offset 128
Bit 1 = Difference/offset 64
Bit 2 = Difference/offset 32
Bit 3 = Difference/offset 16
Bit 4 = Difference/offset 8
Bit 5 = Difference/offset 4
Bit 6 = Difference/offset 2
Bit 7 = Difference/offset 1

When byte 11, bit 0 is on:

Bit 0 = Not used
Bit 1 = Not used
Bit 2 = Not used
Bit 3 = Not used
Bit 4 = Not used
Bit 5 = Not used
Bit 6 = Not used
Bit 7 = Not used

Byte 20

When byte 11, bit 0 is off:

Bit 0 = Target 128
Bit 1 = Target 64
Bit 2 = Target 32
Bit 3 = Target 16
Bit 4 = Target 8
Bit 5 = Target 4
Bit 6 = Target 2
Bit 7 = Target 1

When byte 11, bit 0 is on:

If byte 18, bit 1 is on, bits 0 through 7 contain the microcontroller error code.
If byte 18, bit 1 is off, bits 0 through 7 are not used.

Byte 21

Bits 0 through 3 are not used. Bits 4 through 7 indicate the following error conditions:

0000 = Not used
0001 = Tag Valid indication missing on a read or write operation
0010 = Normal End or Check End indication missing on a read or write operation
0011 = Tag Valid, Normal End, or Check End indication received in response to an operation other than a read or write
0100 = Normal End received before required bytes were transferred
0101 = Not used
0110 = Either more than one controller selected or no controller selected
0111 = Preselection check
1000 = Not used
1001 = Not used
1010 = Incorrect drive selected
1011 = Busy missing after seek start issued
1100 = No block found
1101 = HDA attention detected during device reconnection for disconnected command chain
1110 = Preselection bus check
1111 = Unresettable interrupt

Format 1 (Continued)

Bytes 22 and 23

Bytes 22 and 23 contain the symptom code.

Message Table – Format 1

Sense Byte 7, Bits 4-7 =	Message Code	Message
0000	0	No message. No additional information required.
0001	1	Transmit target error
0010	2	Microcode detected error
0011	3	Transmit difference high error
0100	4	Sync-out timing error
0101	5	Unexpected drive status at initial selection
0110	6	Transmit cylinder address error
0111	7	Transmit head error
1000	8	Transmit difference error
1001	9	Unexpected drive status
1010	A	Seek error
1011	B	Seek incomplete on retry
1100	C	No interrupt from drive
1101	D	Recovered microcontroller check
1110	E	Cannot determine cause of an ID miscompare or check end
1111	F	Microcontroller check

Format 2 – Storage Director Equipment Check

Format 2 is generated to provide sense information when the microcode detects a storage director error condition.

Byte 8	Contents of the transfer complete status (XCS) register
Byte 9	Contents of the transfer error status (XES) register
Byte 10	Contents of the check register
Byte 11	Contents of the channel transfer control (CXC) register
Byte 12	Contents of channel control 2 register
Byte 13	Contents of the device bus out (DBO) register
Byte 14	Contents of the device bus in (DBI) register
Byte 15	Contents of the device tag out (DTO) register
Byte 16	Contents of the device tag gate (DTG) register
Byte 17	Contents of the device tag in (DTI) register
Byte 18	Channel status 2 register
Byte 19	Not used
Byte 20	Reserved for microcode detected check 2 conditions
Byte 21	Storage director ID
Bytes 22 and 23	Symptom code

Message Table – Format 2

Sense Byte 7, Bits 4-7 =	Message Code	Message
0000-0111	0-7	Reserved for other types of storage control units
1000	8	No message, no additional information required
1001	9	Selective reset detected while a drive was selected
1010	A	Failed to latch First Sync In line
1011-1111	B-F	Reserved

Format 3 – Storage Director Control Check (Hardware Detected)

Format 3 is generated to provide sense information for a failing storage director that requires a reset procedure for recovery.

Byte 8	Contents of FRU register 2 (bit 4 = 0)
Byte 9	Contents of check register 1
Byte 10	Contents of check register 2
Byte 11	Contents of check register 3
Byte 12	Not used
Byte 13	Not used
Byte 14	Not used
Byte 15	Contents of FRU register 3
Byte 16	Contents of FRU register 4
Byte 17	Not used
Byte 18	Not used
Byte 19	Not used
Byte 20	Not used
Byte 21	Storage director ID
Bytes 22 and 23	Symptom code

Message Table – Format 3

Sense Byte 7, Bits 4–7 =	Message Code	Message
0000-0111	0-7	Reserved for other types of storage control units
1000	8	No message. No additional information required
1001-1111	9-F	Reserved

Format 3 – Storage Director Control Check (Microcode Detected)

Byte 8	Not used
Byte 9	Contents of the transfer error status (XES) register
Byte 10	Contents of the check register
Byte 11	Contents of the condition register 0 (CR0) register
Byte 12	Contents of the channel status (CS2) register
Byte 13	Contents of the channel control 1 (CC1) register
Byte 14	Contents of the channel control 2 (CC2) register
Byte 15	Contents of the channel status 1 (CS1) register
Byte 16	Contents of the channel status 3 (CS3) register
Byte 17	Contents of the channel transfer control (CXC) register
Byte 18	Contents of the channel bus out (CBO) register
Byte 19	Contents of the channel bus in (CBI) register
Byte 20	Interrupt level
Byte 21	Storage director ID
Bytes 22 and 23	Symptom code

Message Table – Format 3

Sense Byte 7, Bits 4-7 =	Message Code	Message
0000-0111	0-7	Reserved
1000	8	Reserved
1001	9	Channel check 1 or storage director timeout
1010	A	Trace table saved in this storage director
1011-1111	B-F	Reserved

Format 4 – Data Checks Without Displacement Information

Format 4 is generated when:

- Errors that were not correctable by the ECC were detected in the ID or data field. The message code in sense byte 7 identifies the field.
- Error log information is off-loaded after an ECC uncorrectable error occurred during error logging. The information was recovered through use of command retry. Byte 2, bit 3 (environmental data present) is also set.

Bytes 8 Through 15 Locate Parameters

If byte 1, bit 7 (operation incomplete) is set, bytes 8 through 15 contain the Locate parameters. If byte 1, bit 7 is not set or the error was detected during a Diagnostic Sense command, these bytes are zero.

Bytes 16 and 17 Blocks Transferred

Bytes 16 and 17 contain the number of blocks transferred to the system (excluding the error block).

Bytes 18 Through 21 Offset

Bytes 18 through 21 specify, in blocks, the offset of the error block from the beginning of the data set.

Bytes 22 and 23

Bytes 22 and 23 contain the symptom code.

Message Table – Format 4

Sense Byte 7, Bits 4-7 =	Message Code	Message
0000	0	The check byte detected a data error in the ID field.
0001	1	An error occurred in the data area and could not be corrected by the ECC.
0010 and 0011	2,3	Not used.
0100	4	Data synchronization on the ID field was unsuccessful.
0101	5	Data synchronization on the data area was unsuccessful.
0110-1000	6-8	Not used.
1001	9	An error occurred in the data area during a read-back check of a write and check data operation and it could not be corrected by the ECC.
1010-1100	A-C	Not used.
1101	D	Data synchronization on the data area was unsuccessful and the error occurred during a read-back check of a write and check data operation.
1110 and 1111	E,F	Not used.

Format 5 – Data Checks With Displacement Information

Format 5 is generated when:

- Data checks that are correctable by the ECC are detected in the data area of a record.
- Error log information is off-loaded after an ECC correctable error occurred during error logging.

Bytes 8 Through 15 Locate Parameters

If byte 1, bit 7 (operation incomplete) is set, bytes 8 through 15 contain the Locate parameters. If byte 1, bit 7 is not set or if the error occurred during a Diagnostic Sense command, these bytes are zero.

Bytes 16 and 17 Blocks Transferred

Bytes 16 and 17 contain the number of blocks transferred to the system (including the error block).

Bytes 18 and 19 Error Displacement

Bytes 18 and 19 specify the location of the first data byte in error in the data field. The location is relative to the end of the data field.

Bytes 20 Through 23 Error Pattern

These bytes identify the bits in error when the data check is correctable. A 1 in the bit position represents an incorrect bit.

Message Table – Format 5

Sense Byte 7, Bits 4-7 =	Message Code	Message
0000	0	Used for all format 5 data checks
0001-1111	1-F	Not used

Format 6 – Usage Statistics/Overrun Errors

Format 6 is generated when:

- A Read and Reset Buffered Log command is executed.
- Usage/error statistics require off-loading due to counter overflow.

Bytes 8 Through 10 Blocks Read

Bytes 8 through 10 contain an accumulated count of the number of blocks read during read operations.

Bytes 11 and 12 Correctable Data Checks

Bytes 11 and 12 contain an accumulated count of the number of ECC correctable data checks detected by the storage director.

Byte 13 Uncorrectable Data Checks

Byte 13 contains the number of ECC uncorrectable data checks retried by the storage director.

Byte 14 Access Offset Involved

Byte 14 contains the number of ECC uncorrectable data checks retried by the storage director that involved access offset.

Bytes 15 Through 17 Blocks Written With Verify

Bytes 15 through 17 contain the number of blocks written by the 3880 and 3370 with the check data option specified.

Byte 18

Byte 18 is not used.

Bytes 19 and 20 Seeks

Bytes 19 and 20 contain the number of seeks processed by the 3880 and 3370.

Byte 21 Seek Errors

Byte 21 contains the number of seek errors that were retried by the storage director.

Byte 22 Service Overruns

Byte 22 contains the number of service overruns that occurred.

Byte 23 Command Overruns

Byte 23 contains the number of command overruns that were retried by the storage director.

Message Table – Format 6

Sense Byte 7, Bits 4–7 =	Message Code	Message
0000-0111	0–7	Not used.
1000	8	Indicates that the information in bytes 22 and 23 applies to channel A.
1001	9	Indicates that the information in bytes 22 and 23 applies to channel B.
1010	A	Indicates that the information in bytes 22 and 23 applies to channel C.
1011	B	Indicates that the information in bytes 22 and 23 applies to channel C.
1100-1111	C–F	Not used.

Error Condition Table - 3370

Byte	Bit	Name	General Description	Action	Logged
0	0	Command reject	Programming error	2	No
0 1	0 6	Command reject Write inhibited	Write command received with the Write Inhibit switch in the Read-Only position	1	No
0 1	0 7	Command reject Operation incomplete	Alternate space exhausted	1	No
0	1	Intervention required	Drive offline	3	No
0	2	Bus out parity	Bus out parity error occurred	3	Yes
0	3	Equipment check	Equipment malfunction	4A	Yes
0 1	3 0	Equipment check Permanent error	Equipment malfunction and command retry exhausted or undesirable	1	Yes
0 1	3 3	Equipment check Operator message	Permanent equipment malfunction of the alternate storage director or a state save operation in the reporting storage director	4	Yes
0 1	4 0	Data check Permanent error	Uncorrectable data check and command retry exhausted	1	Yes
0 1	4 7	Data check Operation incomplete	Uncorrectable data check in a data area of any block except the first during a read operation	6A	No
0 2	4 1	Data check Correctable	Correctable data check in the last data area during a read operation	5	No
0 2 1	4 1 7	Data check Correctable Operation incomplete	Correctable data check in the data area of any block except the last during a read operation	6	No
0 1	5 0	Overrun Permanent error	Command retry exhausted on a service overrun	1	Yes
0 1	5 7	Overrun Operation incomplete	Service overrun in a data area of any block except the first during a read or write operation with the check data modifier bit off	6A	No
1	1	Block size exception	Invalid block size specified	2	No
1	5	File protected	Locate argument violated the Define Extent specifications	8	No
1	7	Operation incomplete	Seek error after the start of data transfer during a read or update write with the check data modifier bit off	7	No
2	0	Check data error	Uncorrectable data check during a check data operation	4A	Yes

Recovery Action Table – 3370

Action	Explanation
1	Print console error message.
2	Exit with programming error or unusual condition indication.
3	a. Repeat the operation once. b. If the error condition persists, perform action 1.
4	Print console error message for the operator and/or customer engineer. Go to action 4A.
4A	a. Repeat the operation. b. If the error condition persists after ten retries, perform action 1.
5	a. Perform the error correction function. b. Continue the user's chain by executing: Define Extent (one issued in this command chain) TIC (CSW or next non-TIC CCW in the data chain)
6	a. Perform the error correction function. b. Construct restart CCW 2. c. Complete the interrupted operation and continue the user's chain by executing: Define Extent (one issued in this command chain) Locate (parameters from sense bytes 8 through 15) Restart CCW 2 TIC (pointer established while constructing restart CCW 2 + 8)
6A	a. Construct restart CCW2 b. Complete the interrupted operation and continue the user's chain by executing: Define Extent (one issued in this command chain) Locate (parameters from sense bytes 8 through 15) Restart CCW 2 TIC (pointer established while constructing restart CCW 2 + 8)
7	a. Construct the restart CCW 1. b. Complete the interrupted operation and continue the user's chain by executing: Define Extent (one issued in this command chain) Locate (parameters from sense bytes 8 through 15) Restart CCW 1 TIC (CSW)
8	a. If the blocks specified by the Locate command are not in the user's data set, perform action 2. b. If the blocks are within the user's data set, IOS must supply the correct extent limits before issuing the Locate command. Complete the operation by executing: Define Extent (with modified extent limits) TIC (CSW)

Sense Bytes – 3330

Sense information for the 3330 (24 bytes) identifies the conditions that caused the last unit check status to be generated. The sense information also provides secondary information for system error recovery and for diagnosing and isolating storage director and device malfunctions.

Sense Byte 0

Bit 0 Command Reject

Bit 0 is set by:

- An invalid command code
- An invalid command sequence
- An invalid or incomplete argument transferred by a control command
- A track formatted without a home address
- Issuing a write command with the Write Inhibit switch in the Read-Only position
- Attempting a format write command (other than Write Home Address or Write R0) on a defective track
- Issuing a write command that violates the file mask
- A record zero count field of a defective track that points to itself instead of the alternate track

Bit 1 Intervention Required

Bit 1 is set by:

- Addressing a drive that is not attached to the system
- Addressing a drive that is not ready
- Issuing a Diagnostic Write or Diagnostic Load command while an inline diagnostic is resident in control storage

Bit 2 Bus Out Parity

Bit 2 is set when a parity error is detected during transfer of a command from the channel to the 3880.

Bit 3 Equipment Check

Bit 3 is set when an unusual hardware condition occurs in the channel, storage director, or drive. The condition is further defined in sense bytes 7 through 23.

Bit 4 Data Check

Bit 4 is set when the storage director detects a data error in the information received from the drive. If byte 2, bit 1 (correctable) is also set, the data error is correctable and bytes 15 through 23 provide correction information. Sense byte 7 defines the specific nature of the condition.

Bit 5 Overrun

Bit 5 is set when the storage director does not receive a response to a data request within a specified period of time.

Detection of an overrun may cause requests for data from the channel to be terminated. When writing, the remaining portion of the record area is padded with a replicated data byte.

Sense Byte 0 (Continued)

**Bit 5
Overrun
(continued)**

All data overrun conditions are retried by the storage director except those that occur in the second or subsequent segments of an overflow record, those that occur during a format write operation, or those that occur during a Read Multiple Count, Key, and Data command.

The storage director posts an overrun only if the condition occurs more than ten times during a CCW chain, or if the overrun occurs during one of the above operations not retried by the storage director.

Command overruns are also retried by the storage director and do not cause an overrun to be posted.

Bit 6

Bit 6 is not used. It is set to zero.

Bit 7

Bit 7 is not used. It is set to zero.

Sense Byte 1

**Bit 0
Permanent Error**

Bit 0 is set when internal error recovery has been exhausted (through the use of command retry) and was unsuccessful, or when internal error recovery was not possible or desirable.

The bit overrides any other bit settings and indicates that system error recovery procedures may not be required.

Sense Byte 1 (Continued)

Bit 1

Invalid Track Format

Bit 1 is set when:

- An attempt is made to write data exceeding track capacity.
- An index point is detected in the gap that precedes a key or data field.
- A previous operation attempted to write data exceeding the track capacity; this operation resulted in a record written into index. This record was encountered while attempting to execute a read, search, or write command. As long as this record remains on the track, invalid track format may be posted while attempting to locate a record successfully written on the track. However, a Search ID will be able to execute on any count field successfully written on the track without posting invalid track format.

Bit 2

End of Cylinder

Bit 2 is set when:

- A multitrack read or search operation continues past the end of the cylinder boundary.
- An overflow operation continues past the end of the cylinder boundary. Byte 1, bit 7 (operation incomplete) is also set.

Bit 3

Message to Operator

Bit 3 is set when there is a permanent failure in the alternate storage director or a state save operation in the reporting storage director. Byte 0, bit 3 (equipment check) is also set. A message will be sent to the operator console. This bit is used for format 3 only.

Bit 4

No Record Found

Bit 4 is set when two index points have been detected in the same CCW chain without an intervening read operation in the home address area or data area, or without an intervening write, sense, or control command.

Bit 5

File Protected

Bit 5 is set when:

- A seek command violates the file mask.
- A multitrack read or search operation violates the file mask.
- An overflow operation violates the seek portion of the file mask. Byte 1, bit 7 (operation incomplete) is also set.

Bit 6

Write Inhibited

Bit 6 is set when a write command is received for a drive that has its Write Inhibit switch in the Read-Only position. Byte 0, bit 0 (command reject) is also set.

Bit 7

Operation Incomplete

Bit 7 is set when one of the following conditions occurs during the processing of an overflow record.

- An overflow to a file protected boundary. Byte 1, bit 5 (file protected) is also set.
- An overflow past the cylinder boundary. Byte 1, bit 2 (end of cylinder) is also set.
- A correctable data check is detected in a data field other than the last segment. Byte 0, bit 4 (data check) and byte 2, bit 1 (correctable) are also set.
- An uncorrectable data check is detected in any field in other than the first segment.
- A defective or alternate track condition is detected after the start of data transfer.
- A seek error is detected in the second or subsequent segment.

Sense byte 3 provides the restart command, and sense bytes 8 through 13 provide restart information.

Sense Byte 2

- Bit 0** Bit 0 is not used. It is set to zero.
- Bit 1 Correctable** Bit 1 is set when the data check condition indicated by byte 0, bit 4 (data check) is correctable.
- Bit 2** Bit 2 is not used. It is set to zero.
- Bit 3 Environmental Data Present** Bit 3 is set to indicate that bytes 8 through 23 contain usage or error statistics, or error log information. Byte 7 indicates the format for bytes 8 through 23.
- Bits 4 Through 7** Bits 4 through 7 are not used. They are set to zero.

Sense Byte 3

- Bits 0 Through 7 Restart Command** Bits 0 through 7 are set when byte 1, bit 7 (operation incomplete) is set. These bits identify the type of operation in progress when the interrupt occurred. If the bits are set to 0000 0110, a read operation was in progress; if they are set to 0000 0101, a write operation was in progress.

Sense Byte 4

- Bits 0 and 1** Bits 0 and 1 identify the physical controller selected.
- Bits 2 Through 7 Drive Identification** Bits 2 through 7 identify the physical address of each drive.
- | | |
|------------|------------|
| 111000 = A | 011100 = E |
| 110001 = B | 010101 = F |
| 101010 = C | 001110 = G |
| 100011 = D | 000111 = H |

Sense Byte 5

- Bits 0 Through 7 Cylinder-Low Address** Bits 0 through 7 identify the low-order cylinder address of the most recent seek argument from the channel.
- In conjunction with sense format 3 (microcode detected), byte 5 indicates the high-order byte of the instruction address register.
- In conjunction with sense format 6, byte 5 indicates the number of diskette checks after an initial microcode load (IML) or a storage director-to-storage director communication failure.
- | | |
|---|---|
| Bit 0 = Communication failure during an IML | Bits 2-4 = Diskette check (seek errors) |
| Bit 1 = Not used | Bits 5-7 = Diskette check (read errors) |

Sense Byte 6

If an alternate track condition is detected and byte 1, bit 7 (operation incomplete) is posted during an overflow operation, byte 6 is set in the head address of the defective track plus 1. The ERPs use this byte to construct the seek argument to continue the operation. The remainder of the seek argument is obtained from the user, not the sense bytes.

In conjunction with sense format 3 (microcode detected), byte 6 indicates the low-order byte of the instruction address register.

In conjunction with sense format 6, byte 6 identifies the storage director.

In all other cases, sense byte 6 contains the following information.

Bit 0

Bit 0 is not used. It is set to zero.

Bit 1 Cylinder-High Address

3330-1: Bit 1 identifies the high-order bit (256) of the cylinder address in sense byte 5.

3330-11: Bit 1 identifies the high-order bit (512) of the cylinder address in sense byte 5.

Bit 2 Difference

3330-1: Bit 2 is not used. It is set to zero.

3330-11: Bit 2 identifies the high-order bit (256) of the cylinder address in sense byte 5.

Bits 3 Through 7 Head Address

Bits 3 through 7 identify the head address of the last seek (excluding retry seeks). The head address is updated during multitrack and overflow operations.

Sense Byte 7

Bits 0 Through 3 Format

Bits 0 through 3 specify the format of sense bytes 8 through 23 as follows:

0000 = Format 0 – program or system checks

0001 = Format 1 – device equipment checks (CE information)

0010 = Format 2 – storage director equipment checks (CE information)

0011 = Format 3 – storage director control checks (CE information)

0100 = Format 4 – data checks without displacement information

0101 = Format 5 – data checks with displacement information (Format 5 may also be presented on errors which are not ECC correctable but which require restart displacement information.)

0110 = Format 6 – usage statistics/overrun errors

Bits 4 Through 7 Message

Bits 4 through 7 describe the specific nature of the error conditions for each of the above formats. The message table that accompanies the format descriptions specifies the function of the message bits for the format.

Format 0 – Program or System Check

Format 0 is used when sense bytes 0 through 7 completely describe the error or unusual condition caused by a program or system error.

Bytes 8 Through 20

Bytes 8 through 20 are not used. They are set to zero.

Byte 21

Byte 21 contains the storage director ID.

Bytes 22 and 23

Bytes 22 and 23 contain the symptom code.

Message Table – Format 0

Sense Byte 7, Bits 4–7 =	Message Code	Message
0000	0	No message. No additional information is required.
0001	1	An invalid command was issued to the 3880.
0010	2	An invalid command sequence was issued to the 3880.
0011	3	The CCW count was less than required for the command.
0100	4	An invalid data argument was used for the command.
0101	5	A Diagnostic Write command was issued when not permitted by the file mask.
0110	6	Retry status was presented and the channel did not indicate chaining.
0111	7	The command code of the CCW returned after a retry sequence did not match the command for which the retry was signaled.
1000	8	A Diagnostic Load command was issued but the IML device was not ready.
1001	9	A Diagnostic Load command was issued but the IML device had a permanent seek check.
1010	A	A Diagnostic Load command was issued but the IML device had a permanent read check.
1011	B	The alternate track pointer of a defective track pointed to the defective track.
1100	C	Not used.
1101	D	The index point was detected in the gap of a record.
1110 and 1111	E,F	Not used.

Format 1 – Device Equipment Check

Format 1 is generated when:

- A device, device interface, or a controller equipment check is detected. Byte 0, bit 3 (equipment check) is also set.
- A permanent device seek check is detected. Byte 0, bit 3 (equipment check) and byte 1, bit 0 (permanent error) are also set. The message bits in sense byte 7 indicate a seek error.
- Error log information is off-loaded after a successful retried seek that occurred during error logging. Byte 3, bit 2 (environmental data present) is also set. The message bits in sense byte 7 indicate a seek error.
- Byte 8, bit 4 (on line) is off. Byte 0, bit 1 (intervention required) is also set.

Byte 8 Module Status

Bit 0 = Index error	Bit 4 = On line
Bit 1 = Offset active	Bit 5 = Attention
Bit 2 = Seek incomplete	Bit 6 = Busy
Bit 3 = Seek complete	Bit 7 = Record ready

Byte 9 Monitor Mode

Bit 0 = Not used	Bits 5-7 identify the monitor modes as follows:
Bit 1 = Diagnostic state 4	001 = Mode 1 – rezero
Bit 2 = Diagnostic state 2	010 = Mode 2 – seek accelerate
Bit 3 = Diagnostic state 1	100 = Mode 4 – head load
Bit 4 = Not used	101 = Mode 5 – seek decelerate
	110 = Mode 6 – read
	111 = Mode 7 – write

Byte 10 Monitor State

These bits identify a monitor state that exists for each of the monitor modes described in sense byte 9.

Bit 0 = State 8	Bit 4 = State 4
Bit 1 = State 7	Bit 5 = State 3
Bit 2 = State 6	Bit 6 = State 2
Bit 3 = State 5	Bit 7 = State 1

Byte 11 Check Status

Bit 0 = CE program stop	Bit 4 = CTL-I bus out parity
Bit 1 = Not used	Bit 5 = Monitor check
Bit 2 = Not used	Bit 6 = Not used
Bit 3 = Not used	Bit 7 = Drive command reject

Byte 12 Safety

Bit 0 = Data safety	Bit 4 = Power on reset latched
Bit 1 = Servo safety	Bit 5 = Drive power on reset
Bit 2 = Not used	Bit 6 = Not heads loaded
Bit 3 = Pad safety (Model 11)	Bit 7 = Even latch

Byte 13 Device Bus Out

Byte 13 contains the actual device bus out (DBO) value for message code C. It is also set to the DBO value if the message code is 2 and byte 18, bits 4 through 7 are 1, 3, 5, 6, 9 or E. Byte 13 contains the expected device bus in (DBI) value for message codes 1, 3, 6, 7, 8, and 9. Otherwise, it is set to zero.

Format 1 (Continued)

Byte 14 Device Bus In	Byte 14 contains the actual DBI value for message codes 1, 3, 6, 7, 8, 9, and C and for message code 2 if byte 18 equals '01', '03', '05', '06', '09', or 'E'. Otherwise, it is set to zero.
Byte 15 Device Tag Gate	Byte 15 contains the device tag gate (DTG) register value for message codes 1, 3, 6, 7, 8, 9, and C and for message code 2 if byte 18 equals '01', '03', '05', '06', '09', or 'OE'. Otherwise, it is set to zero.
Byte 16 Controller Check 1	Bit 0 = PLO error Bit 1 = Write parity error Bit 2 = Read parity error Bit 3 = Bit ring error Bit 4 = Write compensation check Bit 5 = Data transfer control check Bit 6 = Missing PLO pulses Bit 7 = VFO phase error
Byte 17 Controller Check 2	Bit 0 = ECC no input data Bit 1 = ECC P0 or write Bit 2 = ECC P2 or P3 Bit 3 = ECC P1 Bit 4 = Sync-out check Bit 5 = PLO control check Bit 6 = Gap counter check Bit 7 = Gap control check
Byte 18 Controller Check 3	Bit 0 = Error alert Bit 1 = Select active check Bit 2 = Controller interface bus in check Bit 3 = Not used Bits 4 through 7 indicate the following microcode detected errors: 0000 = No message 0001 = Device interface Tag Valid missing (read or write) 0010 = Device interface Normal End and Check End missing 0011 = Device interface Normal End missing (control operation) 0100 = Either no index for 40 milliseconds, or index on at all times 0101 = Unexpected status with Check End 0110 = 3330 selection check 0111 = Preselection check 1000 = Zero pattern alignment check 1001 = Repetitive command overruns 1010 = Drive interrupt during busy 1011 = Drive status not as expected after a seek or Set Sector command 1100-1110 = Not used 1111 = Always active bus in bit
Byte 19 Controller Check 4	Bit 0 = Drive selection error Bit 1 = CTL-I tag bus check Bit 2 = Device check Bit 3 = CTL-I bus out check Bit 4 = Write sense check Bit 5 = Read/write valid check Bit 6 = DBO register check Bit 7 = Controller bus in assembler check
Bytes 20 and 21	Bytes 20 and 21 are not used.
Bytes 22 and 23	Bytes 22 and 23 contain the symptom code.

Message Table – Format 1

Sense Byte 7, Bits 4-7 =	Message Code	Message
0000	0	No message. No additional information required
0001	1	Set target error
0010	2	Microcode detected error
0011	3	Not used
0100	4	Not used
0101	5	String switch primed interrupt error
0110	6	Transmit cylinder error
0111	7	Transmit head error
1000	8	Transmit difference error
1001	9	Drive status not as expected during execution of a Read IPL or during retry that required the reset of the offset active or set sector bits
1010	A	Seek error
1011	B	Seek incomplete on retry
1100	C	No interrupt from drive
1101	D	ECC P2 or P3 compare failure
1110	E	ECC P1 compare failure
1111	F	Retry PLO counter or sector value incorrect

Format 2 – Storage Director Equipment Check

Format 2 is generated to provide sense information when the microcode detects a storage director error condition.

Byte 8	Contents of the transfer complete status (XCS) register.
Byte 9	Contents of the transfer error status (XES) register
Byte 10	Contents of the check (CHK) register
Byte 11	Contents of the channel transfer complete (CXC) register
Byte 12	Contents of channel control 2 (CC2) register
Byte 13	Contents of the device bus out (DBO) register
Byte 14	Contents of the device bus in (DBI) register
Byte 15	Contents of the device tag out (DTO) register
Byte 16	Contents of the device tag gate (DTG) register
Byte 17	Contents of the device tag in (DTI) register
Byte 18	Contents of channel status 2 (CS2) register
Byte 19	Not used
Byte 20	Byte 20 indicates microcode-detected check 2 conditions. Bits 0 through 3 are not used. If bits 4 through 7 equal 0001, the device attempted to end data transfer prematurely.
Byte 21	Storage director ID
Bytes 22 and 23	Symptom code

Message Table – Format 2

Sense Byte 7, Bits 4-7 =	Message Code	Message
0000-0111	0-7	Reserved for other types of storage control units
1000	8	No message. No additional information required
1001	9	Selective reset occurred while the drive was selected
1010	A	Failed to latch the First Sync In line
1011-1110	B-E	Reserved
1111	F	Microcode detected check. The message appears in byte 20, bits 4 through 7.

Format 3 – Storage Director Control Check (Hardware Detected)

Format 3 is generated to provide sense information for a failing storage director that requires a reset procedure for recovery.

Byte 8	Contents of field-replaceable unit (FRU) register 2 (bit 4 = 0)
Byte 9	Contents of check register 1
Byte 10	Contents of check register 2
Byte 11	Contents of check register 3
Byte 12	Not used
Byte 13	Not used
Byte 14	Contents of FRU register 1
Byte 15	Contents of FRU register 3
Byte 16	Contents of FRU register 4
Byte 17	Not used
Byte 18	Not used
Byte 19	Not used
Byte 20	Not used
Byte 21	Storage director ID
Bytes 22 and 23	Symptom code

Message Table – Format 3

Sense Byte 7, Bits 4-7 =	Message Code	Message
0000-0111	0-7	Reserved for other types of storage control units
1000	8	No message. No additional information required.
1001-1111	9-F	Reserved

Format 3 – Storage Director Control Check (Microcode Detected)

Byte 8	Not used
Byte 9	Contents of the transfer error status (XES) register
Byte 10	Contents of the check register
Byte 11	Contents of the condition register 0 (CR0)
Byte 12	Contents of the channel status 2 (CS2) register
Byte 13	Contents of the channel control 1 (CC1) register
Byte 14	Contents of the channel control 2 (CC2) register
Byte 15	Contents of the channel status 1 (CS1) register
Byte 16	Contents of the channel status 3 (CS3) register
Byte 17	Contents of the channel transfer control (CXC) register
Byte 18	Contents of the channel bus out (CBO) register
Byte 19	Contents of the channel bus in (CBI) register
Byte 20	Interrupt level and block ID
Byte 21	Storage director ID
Bytes 22 and 23	Symptom code

Message Table – Format 3

Sense Byte 7, Bits 4-7 =	Message Code	Message
0000-0111	0-7	Reserved
1000	8	No message (3880 control check)
1001	9	Alternate storage director
1010	A	Trace table saved in this storage director
1011-1111	B-F	Reserved

Format 4 – Data Check Without Displacement Information

Format 4 is generated when:

- Errors that were not correctable by the ECC are detected after retry has been unsuccessful. Byte 1, bit 0 (permanent error) is also set.
- Error log information is off-loaded after an ECC uncorrectable error occurred during error logging. The information was recovered through use of command retry. Byte 2, bit 3 (environmental data present) is also set.
- Data checks are detected while processing a Read Multiple CKD command.

Bytes 8 Through 12
Count ID

Bytes 8 through 12 contain the record ID obtained from the count field of the record in which the error occurred. These bytes are unreliable if the message code in byte 7 is 0, 1, 4, 5, or 9. Byte 12 is zero if the message code is 0 or 4.

Byte 13
Sector Number

Byte 13 contains the sector number of the record in error.

Byte 14
Access Offset

For permanent errors, this byte contains the head offset last used for retrying a data check. If the error was not permanent, this byte provides the offset required to recover from the error.

Byte 15
Retry Count

Byte 15 contains the number of retries required to process the error condition.

Byte 16
Source Drive ID

Byte 16 identifies the physical controller and drive that recorded the data in which the error occurred. (See Sense Byte 4.)

Bytes 17 Through 21

Bytes 17 through 21 are not used.

Bytes 22 and 23

Bytes 22 and 23 contain the symptom code.

Message Table – Format 4

Sense Byte 7, Bits 4–7	Message Code	Message
0000	0	An error occurred in the home address area and could not be corrected by the ECC.
0001	1	An error occurred in the count area and could not be corrected by the ECC.
0010	2	An error occurred in the key area and could not be corrected by the ECC.
0011	3	An error occurred in the data area and could not be corrected by the ECC.
0100	4	Data synchronization on the home address area was unsuccessful.
0101	5	Data synchronization on the count area was unsuccessful.
0110	6	Data synchronization on the key area was unsuccessful.
0111	7	Data synchronization on the data area was unsuccessful.
1000	8	Not used
1001	9	Address mark reorientation was unsuccessful on retry.
1010-1111	A-F	Not used.

Format 5 – Data Check With Displacement Information

Format 5 is generated when:

- Data checks that are correctable by the ECC are detected in the data areas of a record.
- Data checks in data areas that are not correctable by the ECC were successfully retried but the file mask specified PCI fetch mode.
- Error log information is off-loaded after an ECC correctable error occurred during error logging.
- Data checks are detected while processing a second or subsequent segment of an overflow record.

Bytes 8 Through 12 Count ID

Bytes 8 through 12 contain the record ID obtained from the count field of the record in which the error occurred. These bytes are unreliable if the message code in byte 7 is 0, 1, 4, or 5. Byte 12 is unreliable after a Space Count command.

Byte 13 Sector Number

Byte 13 contains the sector number of the record in error.

Byte 14 Access Offset

For permanent errors, this byte contains the head offset last used for retrying a data check. If the error was not permanent, this byte provides the offset required to recover from the error.

Bytes 15 Through 17

Bytes 15 through 17 contain the restart displacement.

Bytes 18 and 19

Bytes 18 and 19 contain the error displacement.

Bytes 20 Through 22

Bytes 20 through 22 contain the error pattern.

Byte 23

Bits 0 through 6 are not used. Bit 7 indicates that the channel truncated data transfer.

Message Table – Format 5

Sense Byte 7, Bits 4-7 =	Message Code	Message
0000	0	Home address data check
0001	1	Count area data check
0010	2	Key area data check
0011	3	Data area data check
0100-1111	4-F	Not used

Format 6 – Usage Statistics/Overrun Errors

Format 6 is generated when:

- A Read and Reset Buffered Log command is executed.
- Usage/error statistics require off-loading due to counter overflow.

Bytes 8 Through 11 Bytes Read or Searched

Bytes 8 through 11 contain an accumulated count of the number of bytes processed by the storage director during read and search operations. (Only key and data area bytes are counted.) Bytes processed during retry operations are not counted.

Bytes 12 and 13 Correctable Data Checks

Bytes 12 and 13 contain the accumulated count of the number of ECC correctable data checks which were detected by the storage director.

Bytes 14 and 15 Uncorrectable Data Checks Retried

Bytes 14 and 15 contain the number of ECC uncorrectable data checks retried by the storage director.

Bytes 16 and 17 Number of Seeks

Bytes 16 and 17 contain the number of access moves processed by the storage director.

Byte 18 Channel Select

Byte 18 specifies which channels the information in bytes 20 through 23 pertain to
Bits 0 and 1:
00 = Channels A and B
10 = Channels C and D
Bits 2 through 7 are not used.

Byte 19 Seek Errors

Byte 19 contains the number of seek errors retried by the storage director.

Byte 20 Command Overruns Channel A or C

Byte 20 contains the number of command overruns that occurred on channel A if byte 18, bit 0 is 0, or on channel C if byte 18, bit 0 is 1.

Byte 21 Data Overruns Channel A or C

Byte 21 contains the number of data overruns that occurred on channel A if byte 18, bit 0 is 0, or on channel C if byte 18, bit 0 is 1.

Byte 22 Command Overruns Channel B or D

Byte 22 contains the number of command overruns that occurred on channel B if byte 18, bit 0 is 0, or on channel D if byte 18, bit 0 is 1.

Byte 23 Data Overruns Channel B or D

Byte 23 contains the number of data overruns that occurred on channel B if byte 18, bit 0 is 0, or on channel D if byte 18, bit 0 is 1.

Message Table – Format 6

Sense Byte 7, Bits 4–7 =	Message Code	Message
0000-0111	0–7	Not used
1000	8	3880 offload
1001-1111	9–F	Not used

Error Condition Table – 3330

The 3330 error condition table is combined with the 3350 error condition table.
See Error Condition Table – 3330/3350.

Recovery Action Table – 3330

The 3330 recovery action table is combined with the 3350 recovery action table.
See Recovery Action Table – 3330/3350.

Sense Bytes – 3350

Sense information for the 3350 (24 bytes) identifies the conditions that caused the last unit check status to be generated. The sense information also provides secondary information for system error recovery and for diagnosing and isolating storage control and device malfunctions.

Sense Byte 0

Bit 0 Command Reject

Bit 0 is set by:

- An invalid command code
- An invalid command sequence
- An invalid or incomplete argument transferred by a control command
- A track formatted without a home address
- Issuing a write command with the Write Inhibit switch in the Read-Only position
- Attempting a format write command (other than Write Home Address or Write R0) on a defective track
- Issuing a write command that violates the file mask
- A record zero count field of a defective track that points to itself instead of to the alternate track

Bit 1 Intervention Required

Bit 1 is set by:

- Addressing a drive that is not attached to the system
- Addressing a drive that is not ready
- Issuing a Diagnostic Write or Diagnostic Load command while an inline diagnostic is resident in control storage
- Addressing a drive that is in CE mode and not available

Bit 2 Bus Out Parity

Bit 2 is set when a parity error is detected during transfer of a command from the channel to the 3880.

Bit 3 Equipment Check

Bit 3 is set when an unusual hardware condition occurs in the channel, storage director, or drive. The condition is further defined in sense bytes 7 through 23.

Bit 4 Data Check

Bit 4 is set when the storage director detects a data error in the information received from the drive. If byte 2, bit 1 (correctable) is also set, the data error is correctable and bytes 15 through 23 provide correction information. If the data error is uncorrectable, sense byte 7 defines the specific nature of the condition.

Sense Byte 0 (Continued)

- Bit 5
Overrun** Bit 5 is set when the storage director does not receive a response to a data request within a specified period of time.
- Detection of an overrun may cause requests for data from the channel to be terminated. When writing, the remaining portion of the record area is padded with a replicated data byte.
- All data overrun conditions are retried by the storage director except those that occur in the second or subsequent sections of an overflow record, or those that occur during a format write operation, or those that occur during a Read Multiple Count, Key, and Data command.
- The storage director posts an overrun only if the condition occurs more than ten times during a CCW chain, or if the overrun occurs during one of the above operations not retried by the storage director.
- Command overruns are also retried by the storage director and do not cause an overrun to be posted.
- Bit 6** Bit 6 is not used. It is set to zero.
- Bit 7** Bit 7 is not used. It is set to zero.

Sense Byte 1

- Bit 0
Permanent Error** Bit 0 is set when internal error recovery has been exhausted (through use of command retry) and was unsuccessful, or when internal error recovery was not possible or desirable.
- The bit overrides any other bit settings and indicates that system error recovery procedures may not be required.

Sense Byte 1 (Continued)

Bit 1

Invalid Track Format

Bit 1 is set when:

- An attempt is made to write data exceeding track capacity
- An index point is detected in the gap that precedes a key or data field
- A previous operation attempted to write data exceeding the track capacity; this operation resulted in a record written into index. This record was encountered while attempting to execute a read, search, or write command. As long as this record remains on the track, invalid track format may be posted while attempting to locate a record successfully written on the track. However, a Search ID will be able to execute on any count field successfully written on the track without posting invalid track format.

Bit 1

Invalid Track Format

Bit 1 is set when:

- An attempt is made to write data exceeding track capacity
- An index point is detected in the gap that precedes a key or data field

Bit 2

End of Cylinder

Bit 2 is set when:

- A multitrack read or search operation continues past the end of the cylinder boundary.
- An overflow operation continues past the end of the cylinder boundary. Byte 1, bit 7 (operation incomplete) is also set.

Bit 3

Message to Operator

Bit 3 is set when there is a permanent failure in the alternate storage director or a state save operation in the reporting storage director. Byte 0, bit 3 (equipment check) is also set. A message is sent to the operator. This bit is used for format 3 only.

Bit 4

No Record Found

Bit 4 is set when two index points have been detected in the same CCW chain without an intervening read operation in the home address area or data area, or without an intervening write, sense, or control command.

Bit 5

File Protected

Bit 5 is set when:

- A seek command violates the file mask.
- A multitrack read or search operation violates the file mask.
- An overflow operation violates the seek portion of the file mask. Byte 1, bit 7 (operation incomplete) is also set.

Bit 6

Write Inhibited

Bit 6 is set when a write command is received for a drive that has its Write Inhibit switch in the Read-Only position. Byte 0, bit 0 (command reject) is also set.

Bit 7

Operation Incomplete

Bit 7 is set when one of the following conditions occurs during the processing of an overflow record.

- An overflow to a file protected boundary occurs. Byte 1, bit 5 (file protected) is also set.
- An overflow past the cylinder boundary occurs. Byte 1, bit 2 (end of cylinder) is also set.
- A correctable data check is detected in a data field other than the last segment. Byte 0, bit 4 (data check) and byte 2, bit 1 (correctable) are also set.
- An uncorrectable data check is detected in any field of any segment other than the first segment.
- A defective or alternate track condition is detected after the start of data transfer.
- A seek error is detected in the second or subsequent segment.

Sense byte 3 provides the restart command, and sense bytes 8 through 13 provide restart information.

Sense Byte 2

- Bit 0** Bit 0 is not used. It is set to zero.
- Bit 1 Correctable** Bit 1 is set when the data check condition indicated by byte 0, bit 4 (data check) is correctable.
- Bit 2 Alternate Controller Selected** Bit 2 is set when the controller in the C2 Model is selected.
- Bit 3 Environmental Data Present** Bit 3 is set to indicate that bytes 8 through 23 contain usage or error statistics, or error log information. Byte 7 indicates the format for bytes 8 through 23.
- Bit 4 Through 7** Bits 4 through 7 are not used. They are set to zero.

Sense Byte 3

- Bits 0 Through 7 Restart Command** Bits 0 through 7 are set when byte 1, bit 7 (operation incomplete) is set. These bits identify the type of operation that was in progress when the interrupt occurred. If the bits are set to 0000 0110, a read operation was in progress; if they are set to 0000 0101, a write operation was in progress.

Sense Byte 4

- Bits 0 Through 7 Drive Identification** Bits 0 through 7 identify the drive associated with the sense information.
- | | |
|-----------------|-----------------|
| Bit 0 = Drive 0 | Bit 4 = Drive 4 |
| Bit 1 = Drive 1 | Bit 5 = Drive 5 |
| Bit 2 = Drive 2 | Bit 6 = Drive 6 |
| Bit 3 = Drive 3 | Bit 7 = Drive 7 |

Sense Byte 5

- Bits 0 Through 7 Cylinder-Low Address** Bits 0 through 7 identify the low-order cylinder address of the most recent seek argument from the channel.
- | | |
|----------------------|--------------------|
| Bit 0 = Cylinder 128 | Bit 4 = Cylinder 8 |
| Bit 1 = Cylinder 64 | Bit 5 = Cylinder 4 |
| Bit 2 = Cylinder 32 | Bit 6 = Cylinder 2 |
| Bit 3 = Cylinder 16 | Bit 7 = Cylinder 1 |
- In conjunction with sense format 3 (microcode detected), byte 5 contains the high-order byte of the instruction address register.
- In conjunction with sense format 6, byte 5 indicates the number of diskette checks after an initial microcode load (IML) or a storage director-to-storage director communication failure.
- | | |
|---|---|
| Bit 0 = Communication failure during an IML | Bits 2-4 = Diskette check (seek errors) |
| Bit 1 = Not used | Bits 5-7 = Diskette check (read errors) |

Sense Byte 6

Bits 0 Through 7 Cylinder-High and Head Address

Bits 0 through 7 identify the high-order cylinder and head address of the most recent seek argument from the channel.

Bit 0 = CE cylinder	Bit 4 = Logical track 8
Bit 1 = Cylinder 512	Bit 5 = Logical track 4
Bit 2 = Cylinder 256	Bit 6 = Logical track 2
Bit 3 = Logical track 16	Bit 7 = Logical track 1

Operations involving head switching update the head address bits (4 through 7) of this byte.

If an alternate track condition is detected and byte 1, bit 7 (operation incomplete) is posted during an overflow operation, byte 6 is set to the head address of the defective track and incremented by 1. The error recovery procedures use this byte to reconstruct the seek argument used to continue the operation.

In conjunction with sense format 3 (microcode detected), byte 6 indicates the low-order byte of the instruction address register.

In conjunction with sense format 6, byte 6 identifies the storage director.

Sense Byte 7

Bits 0 Through 3 Format

Bits 0 through 3 specify the format of sense bytes 8 through 23 as follows:

0000 = Format 0 – program or system check
0001 = Format 1 – device equipment check (CE information)
0010 = Format 2 – storage director equipment check (CE information)
0011 = Format 3 – storage director control check (CE information)
0100 = Format 4 – data check without displacement information
0101 = Format 5 – data check with displacement information (Format 5 may also be presented on errors which are not ECC correctable but which require restart displacement information.)
0110 = Format 6 – usage statistics/overrun errors

Bits 4 Through 7 Message

Bits 4 through 7 describe the specific nature of the error conditions for each of the above formats. The message table that accompanies the format descriptions specifies the function of the message bits for the format.

Format 0 – Program or System Check

Format 0 is used when sense bytes 0 through 7 completely describe the error or unusual condition caused by a program or system error.

Bytes 8 Through 17

Bytes 8 through 17 are not used. They are set to zero.

Bytes 18 Through 23 Skip Displacement

If a Sense command is chained from a successful Read Home Address command and no contingent connection exists, bytes 18 through 23 contain the skip displacement bytes of the track.

If a Sense command is not chained from a Read Home Address and a contingent connection exists, byte 21 contains the storage director ID and bytes 22 and 23 contain the symptom code. Otherwise, bytes 18 through 23 are set to zero.

Message Table – Format 0

Sense Byte 7, Bits 4-7 =	Message Code	Message
0000	0	No message. No additional information required.
0001	1	An invalid command was issued to the 3880.
0010	2	An invalid command sequence was issued to the 3880.
0011	3	The CCW count was less than required for the command.
0100	4	An invalid data argument was used for the command.
0101	5	A Diagnostic Write command was issued when not permitted by the file mask.
0110	6	Retry status was presented and the channel did not indicate chaining.
0111	7	The command code of the CCW that was returned after a retry sequence did not match the command for which the retry was signaled.
1000	8	A Diagnostic Load command was issued but the IML device is not ready.
1001	9	A Diagnostic Load command was issued but the IML device had a permanent seek check.
1010	A	A Diagnostic Load command was issued but the IML device had a permanent read check.
1011	B	The alternate track pointer of a defective track pointed to the defective track.
1100	C	Unconditionally reserved.
1101-1111	D-F	Not used.

Format 1 – Device Equipment Check

Format 1 is generated when:

- A device, device interface, or a controller equipment check is detected. Byte 0, bit 3 (equipment check) is also set.
- A permanent device seek check is detected. Byte 0, bit 3 (equipment check) and byte 1, bit 0 (permanent error) are also set. The message bits in sense byte 7 indicate a seek error.
- Error log information is off-loaded after a successful retried seek due to a seek check that occurred during error logging. Byte 3, bit 2 (environmental data present) is also set. The message bits in sense byte 7 indicate a seek error.
- Byte 8, bit 4 (on line) is off. Byte 0, bit 1 (intervention required) is also set.

Byte 8 Drive Status

When byte 19, bit 0 (set R/W) is off:

Bit 0 = Controller check

Bit 1 = Device interface check

Bit 2 = Drive check

Bit 3 = R/W check

Bit 4 = On line

Bit 5 = HDA attention

Bit 6 = Busy

Bit 7 = Seek complete, search sector, or pad complete. If bit 6 is on, search sector is in progress.

When byte 19, bit 0 is on:

Bit 0 = Controller check

Bit 1 = Initialize write sense

Bit 2 = Drive check

Bit 3 = R/W check

Bit 4 = On line

Bit 5 = Pad in progress

Bit 6 = Index mark

Bit 7 = 3330 modes

Byte 9 Drive Checks

Bit 0 = Pad in progress

Bit 1 = Sector compare check

Bit 2 = Motor-at-speed switch latched

Bit 3 = Air switch latched

Bit 4 = Write enable

Bit 5 = FH HDA installed

Bit 6 = Spindle mode 2

Bit 7 = Spindle mode 1

Byte 10 DM Sequence Control

Bit 0 = Mode size check

Bit 1 = HDA sequence latch 4

Bit 2 = HDA sequence latch 2

Bit 3 = HDA sequence latch 1

Bit 4 = Timer latch

Bit 5 = HDA sequence check latched

Bit 6 = Not used

Bit 7 = Odd physical track

Byte 11 Load Switch Status

Bit 0 = Drive start switch

Bit 1 = Guardband pattern

Bit 2 = Target velocity

Bit 3 = Track crossing

Bit 4 = Not used

Bit 5 = Air switch

Bit 6 = Not used

Bit 7 = Motor-at-speed switch

Format 1 (Continued)

Byte 12 R/W Safety

Bit 0 = Multiple-head select check
Bit 1 = Capable/enable check
Bit 2 = Write overrun
Bit 3 = Index check

Bit 4 = Delta current check
Bit 5 = Control check
Bit 6 = Write transition check
Bit 7 = Write current during read check

Byte 13 Control Interface Check

Byte 13 contains the actual DBO value for message code C, and for message code 2, if byte 18 equals '01', '03', '05', '06', '09', or '0E'. Byte 13 contains the expected DBI value for messages 1, 3, 5, 6, 7, 8, and 9.

If bits 4 through 7 of byte 7 equal 1010, or if they equal 1011 and bit 1 of byte 9 equals 0, byte 13 contains the low physical cylinder address of the previous seek.

Bit 0 = 128
Bit 1 = 64
Bit 2 = 32
Bit 3 = 16

Bit 4 = 8
Bit 5 = 4
Bit 6 = 2
Bit 7 = 1

Otherwise, byte 13 is set to zero.

Byte 14 Control Interface Bus In

Byte 14 contains the actual DBI value for messages 1, 3, 5, 6, 7, 8, 9, and C and for message 2 if byte 18 equals '01', '03', '05', '06', '09', or '0E'.

If bits 4 through 7 of byte 7 equal 1010, or if they equal 1011 and bit 1 of byte 9 equals 0, byte 14 contains the high physical cylinder address and physical head address of the previous seek.

Bit 0 = 512
Bit 1 = 256
Bit 2 = 32
Bit 3 = 16

Bit 4 = 8
Bit 5 = 4
Bit 6 = 2
Bit 7 = 1

Otherwise byte 14 is set to zero.

Byte 15 Control Interface Tag Bus

Byte 15 contains the actual DTO value for message codes 1, 3, 5, 6, 7, 8, 9, and C, and message code 2 if byte 18 equals '01', '03', '05', '06', '09', or '0E'. Otherwise, byte 15 is set to zero.

Byte 16 Access Status

Bit 0 = Access time-out check
Bit 1 = Overshoot check
Bit 2 = Servo off-track check
Bit 3 = Rezero mode latch

Bit 4 = Servo latch
Bit 5 = Linear mode latch
Bit 6 = Control latch
Bit 7 = Wait latch

Byte 17

Bit 0 = VFO detected error, 2 bit
Bit 1 = VFO detected error, 1 bit
Bit 2 = SERDES check
Bit 3 = Gap counter check

Bit 5 = Write data check
Bit 6 = Monitor check
Bit 7 = ECC check
Bit 8 = ECC zero detected

Format 1 (Continued)

**Byte 18
Microcode Detected Errors**

Bits 0 through 3 are not used. Bits 4 through 7 indicate the following error conditions:

- 0000 = Not used
- 0001 = Tag Valid indication missing on a read or write operation
- 0010 = Normal End or Check End indication missing on a read, write, or ECC operation
- 0011 = No response from the controller on a control operation
- 0100 = A time out occurred while waiting for index
- 0101 = ECC hardware check
- 0110 = Either more than one controller was selected or no controller was selected
- 0111 = Preselection check
- 1000 = Repetitive command overruns on gap 1 operations
- 1001 = Repetitive command overruns
- 1010 = Incorrect drive selected
- 1011 = Busy missing after seek start was issued
- 1100 = Not used
- 1101 = Not used
- 1110 = Always active bus in bit
- 1111 = Interrupt cannot be reset

**Byte 19
Status**

- | | |
|--------------------|----------------------------|
| Bit 0 = Set R/W on | Bit 4 = Head short check |
| Bit 1 = Reserved | Bit 5 = Pad gate check |
| Bit 2 = Reserved | Bit 6 = 3350 drive |
| Bit 3 = Reserved | Bit 7 = Fixed head feature |

**Byte 20
Interface Checks**

When byte 7, bits 4 through 7 are not equal to 1010, or when they equal 1010 and byte 8, bit 2 is on, the bits in byte 20 have the following meaning:

- | | |
|--|---|
| Bit 0 = Control interface tag bus parity check | Bit 4 = Control interface bus in parity check |
| Bit 1 = Control interface bus out parity check | Bit 5 = Initialize write failure |
| Bit 2 = Drive selection check | Bit 6 = Not used |
| Bit 3 = Device bus in parity check | Bit 7 = Reorient counter check |

When byte 8, bit 2 is off and message A is indicated in sense byte 7, byte 20 contains the present seek address and low physical cylinder address.

- | | |
|----------------------|--------------------|
| Bit 0 = Cylinder 128 | Bit 4 = Cylinder 8 |
| Bit 1 = Cylinder 64 | Bit 5 = Cylinder 4 |
| Bit 2 = Cylinder 32 | Bit 6 = Cylinder 2 |
| Bit 3 = Cylinder 16 | Bit 7 = Cylinder 1 |

Format 1 (Continued)

Byte 21 Device Interface Check

When byte 7, bits 4 through 7 are not equal to 1010, or when they equal 1010 and byte 8, bit 2 is on, byte 21 contains device interface check information.

Bit 0 = Not used
Bit 1 = Not used
Bit 2 = Not used
Bit 3 = Not used

Bit 4 = Not used
Bit 5 = Not used
Bit 6 = Device bus out parity check
Bit 7 = Device tag parity check

When byte 8, bit 2 is off and message A is indicated in sense byte 7, byte 21 contains the high physical cylinder and physical head address of the present seek.

Bit 0 = Cylinder 512
Bit 1 = Cylinder 256
Bit 2 = Cylinder 32
Bit 3 = Cylinder 16

Bit 4 = Cylinder 8
Bit 5 = Cylinder 4
Bit 6 = Cylinder 2
Bit 7 = Cylinder 1

Bytes 22 and 23

Bytes 22 and 23 contain the symptom code.

Message Table – Format 1

Sense Byte, Bits 4-7 =	Message Code	Message
0000	0	No message. No additional information required
0001	1	Transmit target error
0010	2	Microcode detected error
0011	3	Transmit difference-high error
0100	4	Sync-out timing error
0101	5	Unexpected drive status at initial selection
0110	6	Transmit cylinder address error
0111	7	Transmit head error
1000	8	Transmit difference error
1001	9	Unexpected drive status
1010	A	Seek error
1011	B	Seek incomplete on retry or sector non-compare
1100	C	No interrupt from drive
1101	D	Defect skipping— re-orientation check
1110	E	Unable to determine device type during initial selection
1111	F	Retry orientation check

Format 2 – Storage Director Equipment Check

Format 2 is generated to provide sense information when the microcode detects a storage director error condition.

Byte 8	Contents of the transfer complete status (XCS) register
Byte 9	Contents of the transfer error status (XES) register
Byte 10	Contents of the check (CHK) register
Byte 11	Contents of the channel transfer complete (CXC) register
Byte 12	Contents of channel control 2 (CC2) register
Byte 13	Contents of the device bus out (DBO) register
Byte 14	Contents of the device bus in (DBI) register
Byte 15	Contents of the device tag out (DTO) register
Byte 16	Contents of the device tag gate (DTG) register
Byte 17	Contents of the device tag in (DTI) register
Byte 18	Contents of channel status 2 (CS2) register
Byte 19	Not used
Byte 20	Byte 20 indicates microcode-detected checks. Bits 0 through 3 are not used. If bits 4 through 7 equal 0001, the device attempted to end data transfer prematurely. If bits 4 through 7 equal 0010, selection was lost at the time a device error was detected.
Byte 21	Storage director ID
Bytes 22 and 23	Symptom code

Message Table – Format 2

Sense Byte 7, Bits 4–7 =	Message Code	Message
0000–0111	0–7	Reserved for other types of storage control units
1000	8	No message. No additional information required.
1001	9	Selective reset occurred while the drive was selected
1010	A	Failed to latch the First Sync In line
1011–1110	B–E	Reserved
1111	F	Microcode detected check. The message appears in byte 20, bits 4 through 7.

Format 3 – Storage Director Control Check (Hardware Detected)

Format 3 is generated to provide sense information for a failing storage director that requires a reset procedure for recovery.

Byte 8	Contents of FRU register 2 (bit 4 = 0)
Byte 9	Contents of Check register 1
Byte 10	Contents of Check register 2
Byte 11	Contents of Check register 3
Byte 12	Not used
Byte 13	Not used
Byte 14	Contents of FRU register 1
Byte 15	Contents of FRU register 3
Byte 16	Contents of FRU register 4
Byte 17	Not used
Byte 18	Not used
Byte 19	Not used
Byte 20	Not used
Byte 21	Storage director ID
Bytes 22 and 23	Symptom code

Message Table – Format 3

Sense Byte 7, Bits 4-7 =	Message Code	Message
0000-0111	0-7	Reserved for other types of storage control units
1000	8	No message. No additional information required
1001-1111	9-F	Reserved

Format 3 – Storage Director Control Check (Microcode Detected)

Byte 8	Contents of FRU register 2 (bit 4 = 1)
Byte 9	Contents of the transfer error status (XES) register
Byte 10	Contents of the check register
Byte 11	Contents of the condition register 0 (CRO)
Byte 12	Contents of the channel status 2 (CS2) register
Byte 13	Contents of the channel control 1 (CC1) register
Byte 14	Contents of the channel control 2 (CC2) register
Byte 15	Contents of the channel status 1 (CS1) register
Byte 16	Contents of the channel status 3 (CS3) register
Byte 17	Contents of the channel transfer control (CXC) register
Byte 18	Contents of the channel bus out (CBO) register
Byte 19	Contents of the channel bus in (CBI) register
Byte 20	Interrupt level and block ID
Byte 21	Storage director ID
Bytes 22 and 23	Symptom code

Message Table – Format 3

Sense Byte 7, Bits 4-7 =	Message Code	Message
0000-0111	0-7	Reserved
1000	8	No message (3880 control check)
1001	9	Alternate storage director
1010	A	Trace table saved in this storage director
1011-1111	B-F	Reserved

Format 4 – Data Check Without Displacement Information

Format 4 is generated when:

- Errors that are not correctable by the ECC are detected after retry has been unsuccessful. Byte 1, bit 0 (permanent error) is also set.
- Error log information is off-loaded after an ECC uncorrectable error occurred during error logging. The information is recovered through use of command retry. Byte 2, bit 3 (environmental data present) is also set.
- Data checks were detected while processing a Read Multiple CKD command.

Bytes 8 Through 12 Count ID

Bytes 8 through 12 contain the record ID obtained from the count field of the record in which the error occurred. These bytes are unreliable if the message code in byte 7 is 0, 1, 4, 5, or 9. Byte 12 is zero if the message code is 0 or 4.

Byte 13 Sector Number

Byte 13 contains the sector number of the record in error.

Bytes 14 Through 21

Bytes 14 through 21 are not used.

Bytes 22 and 23

Bytes 22 and 23 contain the symptom code.

Message Table – Format 4

Sense Byte 7, Bits 4-7 =	Message Code	Message
0000	0	An error occurred in the home address area and could not be corrected by the ECC.
0001	1	An error occurred in the count area and could not be corrected by the ECC.
0010	2	An error occurred in the key area and could not be corrected by the ECC.
0011	3	An error occurred in the data area and could not be corrected by the ECC.
0100	4	Data synchronization on the home address area was unsuccessful.
0101	5	Data synchronization on the count area was unsuccessful.
0110	6	Data synchronization on the key area was unsuccessful.
0111	7	Data synchronization on the data area was unsuccessful.
1000	8	Not used.
1001	9	No address mark was detected upon retry.
1010-1111	A-F	Not used.

Format 5 – Data Check With Displacement Information

Format 5 is generated when:

- Data checks that are correctable by the ECC are detected in the data areas of a record.
- Data checks in data areas that are not correctable by the ECC were successfully retried but the file mask specified PCI fetch mode.
- Error log information is off-loaded after an ECC correctable error occurred during error logging.
- Data checks are detected while processing a second or subsequent segment of an overflow record.

**Bytes 8 Through 12
Count ID**

Bytes 8 through 12 contain the record ID obtained from the count field of the record in which the error occurred.

**Byte 13
Sector Number**

Byte 13 contains the sector number of the record in error.

Byte 14

Byte 14 is not used.

Bytes 15 Through 17

Bytes 15 through 17 contain the restart displacement.

Bytes 18 and 19

Bytes 18 and 19 contain the error displacement.

Bytes 20 Through 22

Bytes 20 through 22 contain the error pattern.

Byte 23

Byte 23 is not used.

Message Table – Format 5

Sense Byte 7, Bits 4-7 =	Message Code	Message
0000-0010	0-2	Not used
0011	3	Data area data check
0100-1111	4-F	Not used

Format 6 – Usage Statistics/Overrun Errors

Format 6 is generated when:

- A Read and Reset Buffered Log command is executed.
- Usage/error statistics require off-loading due to counter overflow.

Bytes 8 Through 11 Bytes Read or Searched

Bytes 8 through 11 contain an accumulated count of the number of bytes processed by the storage director during read and search operations. (Only key and data area bytes are counted.) Bytes processed during retry operations are not counted.

Bytes 12 and 13

Bytes 12 and 13 are not used.

Bytes 14 and 15

Bytes 14 and 15 contain the number of ECC uncorrectable data errors retried by the storage director.

Bytes 16 and 17 Number of Seeks

Bytes 16 and 17 contain the number of seek commands processed by the storage director.

Byte 18 Channel Select

Byte 18 specifies which channels the information in bytes 20 through 23 pertain to.

If bits 0 and 1 are:

00 = Channels A and B

10 = Channels C and D

Bits 2 through 7 are not used.

Byte 19 Seek Errors

Byte 19 contains the number of seek errors retried by the storage director.

Byte 20 Command Overruns Channel A or C

Byte 20 contains the number of command overruns that occurred on channel A if byte 18, bit 0 is 0, or on channel C if byte 18, bit 0 is 1.

Byte 21 Data Overruns Channel A or C

Byte 21 contains the number of data overruns that occurred on channel A if byte 18, bit 0 is 0, or on channel C if byte 18, bit 0 is 1.

Byte 22 Command Overruns Channel B or D

Byte 22 contains the number of command overruns that occurred on channel B if byte 18, bit 0 is 0, or on channel D if byte 18, bit 0 is 1.

Byte 23 Data Overruns Channel B or D

Byte 23 contains the number of data overruns that occurred on channel B if byte 18, bit 0 is 0, or on channel D if byte 18, bit 0 is 1.

Message Table – Format 6

Sense Byte 7, Bits 4–7	Message Code	Message
0000-0111	0–7	Not used
1000	8	3880 offload
1001-1111	9–F	Not used

Error Condition Table – 3330/3350

Byte	Bit	Name	General Description	Action	Logged
0	0	Command reject	Programming error	2	No
0	0	Command reject	A Write command received with the Write Inhibit switch in the Read-Only position	1	No
1	6	Write inhibited			
0	1	Intervention required	Drive offline or not plugged for the address	3	No-3330 Yes-3350 (See note)
0	2	Bus out parity	Bus out parity error	3	Yes
0	3	Equipment check	Equipment malfunction	4	Yes
0	3	Equipment check	Equipment malfunction Storage director retry exhausted or undesirable	1	Yes
1	0	Permanent error			
0	3	Equipment check	Permanent equipment malfunction of the alternate storage director or a state save operation in reporting storage director.	4A	Yes
1	3	Message to operator			
0	4	Data check	Data check not correctable with a Read Multiple CKD command	4	No-3330 Yes-3350
0	4	Data check	Uncorrectable data check, storage control retry exhausted	1	Yes
1	0	Permanent error			
0	4	Data check	Data check in the second or subsequent overflow segment but not a data field correctable error	6A	No-3330 Yes-3350
1	7	Operation incomplete			
0	4	Data check	Correctable data check in the data area of an overflow segment, not the last segment	6	No-3330 Yes-3350
1	7	Operation incomplete			
2	1	Correctable			
0	4	Data check	Correctable data check in the data area, data area of the last overflow segment, or Read Multiple CKD	5	No-3330 Yes-3350
2	1	Correctable			
0	5	Overrun	Service overrun on second or subsequent segment of a format write or a Read Multiple CKD	4	Yes
1	1	Invalid track format	Track capacity exceeded	2	No
1	2	End of cylinder	Cylinder boundary detected during a basic multitrack operation	8	No
1	2	End of cylinder	Cylinder boundary detected during a basic overflow operation	9	No
1	7	Operation incomplete			
1	4	No record found	Record not found in the basic command sequence	2	No
1	5	File protected	The Seek command or read and/or search multitrack operation violated the file mask.	10	No
1	5	File protected	A read or write overflow violated the file mask.	11	No
1	7	Operation incomplete			
1	7	Operation incomplete			
1	7	Operation incomplete	After start of data transfer during an overflow operation, either a defective or alternate track condition, or a seek error in the second or subsequent segment was found.	7	No
2	3	Environmental data present	Statistical usage/error log information is present.	3	Yes

Note: For the 3350 if sense byte 10, bits 4 and 5 are 0, no recording action is performed.

Recovery Action Table – 3330/3350

Action	Explanation														
1	Print console error message.														
2	Exit with programming error or unusual condition indication.														
3	a. Repeat the operation once. b. If the error condition persists, perform action 1.														
4	a. Repeat the operation. b. If the error condition persists after ten retries, perform action 1.														
4A	a. Print the console message requesting CE notification. b. Repeat the operation once. c. If the error condition persists, perform action 1.														
5	a. Perform the error correction function. b. Examine bit 7 of the file mask. If off, go to step c. If on, indicate that the data has been corrected. The user is operating in PCI fetch mode and must supply the restart recovery action. c. Examine the interrupted CCW (CSW-8). If it is a Read Multiple CKD ('5E'), perform action 5B; otherwise, continue. If the user's chain is not complete, examine the next non-TIC command in the chain. If the CCW is a Write Special CKD, Read Sector, or if bits 3, 6, and 7 are equal to 000 or 011, go to step d. Otherwise, perform action 5A. d. Continue the user's chain by executing: <table border="0" style="margin-left: 2em;"> <tr> <td>Seek</td> <td>(see note below)</td> </tr> <tr> <td>Set File Mask</td> <td>(same as original)</td> </tr> <tr> <td>Read Home Address</td> <td>(skip bit on)</td> </tr> <tr> <td>Search ID Equal</td> <td>(CCHHR from sense bytes 8 through 12)</td> </tr> <tr> <td>TIC*-8</td> <td></td> </tr> <tr> <td>TIC</td> <td>(channel status word)</td> </tr> </table>	Seek	(see note below)	Set File Mask	(same as original)	Read Home Address	(skip bit on)	Search ID Equal	(CCHHR from sense bytes 8 through 12)	TIC*-8		TIC	(channel status word)		
Seek	(see note below)														
Set File Mask	(same as original)														
Read Home Address	(skip bit on)														
Search ID Equal	(CCHHR from sense bytes 8 through 12)														
TIC*-8															
TIC	(channel status word)														
5A	Continue the user's chain by executing: <table border="0" style="margin-left: 2em;"> <tr> <td>Seek</td> <td>(see note below)</td> </tr> <tr> <td>Set File Mask</td> <td>(same as original)</td> </tr> <tr> <td>Read Home Address</td> <td>(skip bit on)</td> </tr> <tr> <td>Search ID Equal</td> <td>(CCHHR from sense bytes 8 through 12)</td> </tr> <tr> <td>TIC*-8</td> <td></td> </tr> <tr> <td>Read Count</td> <td>(skip bit on)</td> </tr> <tr> <td>TIC</td> <td>(channel status word)</td> </tr> </table>	Seek	(see note below)	Set File Mask	(same as original)	Read Home Address	(skip bit on)	Search ID Equal	(CCHHR from sense bytes 8 through 12)	TIC*-8		Read Count	(skip bit on)	TIC	(channel status word)
Seek	(see note below)														
Set File Mask	(same as original)														
Read Home Address	(skip bit on)														
Search ID Equal	(CCHHR from sense bytes 8 through 12)														
TIC*-8															
Read Count	(skip bit on)														
TIC	(channel status word)														
5B	This action is used to restart a Read Multiple CKD data recovery process after a correctable data check has been processed. Reconstruct the Read Multiple CKD as follows: <ol style="list-style-type: none"> a. Construct restart CCW 2. b. Set command code to '5E'. Restart the operation by executing: <table border="0" style="margin-left: 2em;"> <tr> <td>Seek</td> <td>(see note below)</td> </tr> <tr> <td>Set File Mask</td> <td>(same as original)</td> </tr> <tr> <td>Read Home Address</td> <td>(skip bit on)</td> </tr> <tr> <td>Search ID Equal</td> <td>(CCHHR from sense bytes 8 through 12)</td> </tr> <tr> <td>TIC*-8</td> <td></td> </tr> <tr> <td>Read Multiple CKD</td> <td>(from step a)</td> </tr> <tr> <td>TIC (CSW)</td> <td>(if the user's chain has not been completed)</td> </tr> </table>	Seek	(see note below)	Set File Mask	(same as original)	Read Home Address	(skip bit on)	Search ID Equal	(CCHHR from sense bytes 8 through 12)	TIC*-8		Read Multiple CKD	(from step a)	TIC (CSW)	(if the user's chain has not been completed)
Seek	(see note below)														
Set File Mask	(same as original)														
Read Home Address	(skip bit on)														
Search ID Equal	(CCHHR from sense bytes 8 through 12)														
TIC*-8															
Read Multiple CKD	(from step a)														
TIC (CSW)	(if the user's chain has not been completed)														

Note: Cylinder bytes and the high-order head bytes are obtained from the user, not from the sense bytes. The low-order head byte is obtained from sense byte 6, bits 3 through 7.

Recovery Action Table – 3330/3350 (Continued)

Action	Explanation														
6	<p>a. Perform the error correction function.</p> <p>b. Examine bit 7 of the file mask (PCI). If off, go to step c. If on, return to the user with an indication that the data has been corrected. The user is operating in PCI fetch mode and must supply the restart recovery action.</p> <p>c. Increment the seek argument by 1. (See note below.)</p> <p>d. Construct restart CCW 2.</p> <p>e. Complete the interrupted operation and continue the user's chain (if appropriate) by executing:</p> <table border="0" style="margin-left: 2em;"> <tr> <td>Seek</td> <td>(increment seek argument by 1; see note below)</td> </tr> <tr> <td>Set File Mask</td> <td>(same as original)</td> </tr> <tr> <td>Set Sector</td> <td>(argument 0)</td> </tr> <tr> <td>Search ID Equal</td> <td>(record 1)</td> </tr> <tr> <td>TIC*-8</td> <td></td> </tr> <tr> <td>Restart CCW 2</td> <td></td> </tr> <tr> <td>TIC</td> <td>(pointer established while constructing restart CCW 2 + 8)</td> </tr> </table> <p>If the modified seek argument is not within the user's extent, IOS must supply the correct seek argument before issuing the Seek. If that is impossible, then IOS must perform action 2.</p>	Seek	(increment seek argument by 1; see note below)	Set File Mask	(same as original)	Set Sector	(argument 0)	Search ID Equal	(record 1)	TIC*-8		Restart CCW 2		TIC	(pointer established while constructing restart CCW 2 + 8)
Seek	(increment seek argument by 1; see note below)														
Set File Mask	(same as original)														
Set Sector	(argument 0)														
Search ID Equal	(record 1)														
TIC*-8															
Restart CCW 2															
TIC	(pointer established while constructing restart CCW 2 + 8)														
6A	<p>a. Examine bit 7 of the file mask (PCI). If off, go to step b. If on, indicate that data has been corrected. The user is operating in PCI fetch mode and must supply the restart recovery action.</p> <p>b. Construct restart CCW 2.</p> <p>c. Complete the interrupted operation and continue the user's chain (if appropriate) by executing:</p> <table border="0" style="margin-left: 2em;"> <tr> <td>Seek</td> <td>(see note below)</td> </tr> <tr> <td>Set File Mask</td> <td>(same as original)</td> </tr> <tr> <td>Set Sector</td> <td>(argument 0)</td> </tr> <tr> <td>Search ID Equal</td> <td>(record 1)</td> </tr> <tr> <td>TIC*-8</td> <td></td> </tr> <tr> <td>Restart CCW 2</td> <td></td> </tr> <tr> <td>TIC</td> <td>(pointer established while constructing restart CCW 2 + 8)</td> </tr> </table>	Seek	(see note below)	Set File Mask	(same as original)	Set Sector	(argument 0)	Search ID Equal	(record 1)	TIC*-8		Restart CCW 2		TIC	(pointer established while constructing restart CCW 2 + 8)
Seek	(see note below)														
Set File Mask	(same as original)														
Set Sector	(argument 0)														
Search ID Equal	(record 1)														
TIC*-8															
Restart CCW 2															
TIC	(pointer established while constructing restart CCW 2 + 8)														
7	<p>a. Construct restart CCW 1.</p> <p>b. Continue the user's chain by executing:</p> <table border="0" style="margin-left: 2em;"> <tr> <td>Seek</td> <td>(see note below)</td> </tr> <tr> <td>Set File Mask</td> <td>(same as original)</td> </tr> <tr> <td>Set Sector</td> <td>(argument 0)</td> </tr> <tr> <td>Search ID Equal</td> <td>(record 1)</td> </tr> <tr> <td>TIC*-8</td> <td></td> </tr> <tr> <td>Restart CCW 1</td> <td></td> </tr> <tr> <td>TIC</td> <td>(channel status word)</td> </tr> </table>	Seek	(see note below)	Set File Mask	(same as original)	Set Sector	(argument 0)	Search ID Equal	(record 1)	TIC*-8		Restart CCW 1		TIC	(channel status word)
Seek	(see note below)														
Set File Mask	(same as original)														
Set Sector	(argument 0)														
Search ID Equal	(record 1)														
TIC*-8															
Restart CCW 1															
TIC	(channel status word)														

Note: Cylinder bytes and the high-order head bytes are obtained from the user, not from the sense bytes. The low-order head byte is obtained from sense byte 6, bits 3 through 7.

Recovery Action Table – 3330/3350 (Continued)

Action	Explanation														
8	<p>a. Increment the cylinder address of the user's seek argument by 1. Reset the head address.</p> <p>b. Continue the operation by executing:</p> <table border="0"> <tr> <td>Seek</td> <td>(argument from step a)</td> </tr> <tr> <td>Set File Mask</td> <td>(same as original)</td> </tr> <tr> <td>Set Sector</td> <td>(argument 0)</td> </tr> <tr> <td>Read Home Address</td> <td>(skip bit is on)</td> </tr> <tr> <td>TIC</td> <td>(channel status word-8)</td> </tr> </table> <p>If the modified seek argument is not within the user's extent, IOS must supply the correct seek argument before issuing the Seek. If that is impossible, IOS must perform action 2.</p>	Seek	(argument from step a)	Set File Mask	(same as original)	Set Sector	(argument 0)	Read Home Address	(skip bit is on)	TIC	(channel status word-8)				
Seek	(argument from step a)														
Set File Mask	(same as original)														
Set Sector	(argument 0)														
Read Home Address	(skip bit is on)														
TIC	(channel status word-8)														
9	<p>a. Increment the cylinder address of the user's seek argument by 1. Reset the head address.</p> <p>b. Construct restart CCW 1.</p> <p>c. Complete the interrupted operation and continue the user's chain (if appropriate) by executing:</p> <table border="0"> <tr> <td>Seek</td> <td>(argument from step a)</td> </tr> <tr> <td>Set File Mask</td> <td>(same as original)</td> </tr> <tr> <td>Set Sector</td> <td>(argument 0)</td> </tr> <tr> <td>Search ID Equal</td> <td>(record 1)</td> </tr> <tr> <td>TIC*-8</td> <td></td> </tr> <tr> <td>Restart CCW 1</td> <td></td> </tr> <tr> <td>TIC</td> <td>(channel status word)</td> </tr> </table> <p>If the modified seek argument is not within the user's extent, IOS must supply the correct seek argument before issuing the Seek. If that is impossible, IOS must perform action 2.</p>	Seek	(argument from step a)	Set File Mask	(same as original)	Set Sector	(argument 0)	Search ID Equal	(record 1)	TIC*-8		Restart CCW 1		TIC	(channel status word)
Seek	(argument from step a)														
Set File Mask	(same as original)														
Set Sector	(argument 0)														
Search ID Equal	(record 1)														
TIC*-8															
Restart CCW 1															
TIC	(channel status word)														
10	<p>a. Determine if the interrupted command is a seek. If it is, go to step b. If not, perform action 10A.</p> <p>b. Continue the operation by executing:</p> <table border="0"> <tr> <td>Seek</td> <td>(user's argument)</td> </tr> <tr> <td>Set File Mask</td> <td>(same as original)</td> </tr> <tr> <td>Set Sector</td> <td>(argument 0)</td> </tr> <tr> <td>Read Home Address</td> <td>(skip bit on)</td> </tr> <tr> <td>TIC</td> <td>(channel status word)</td> </tr> </table> <p>If the seek argument is not within the user's extent, IOS must supply the correct seek argument before issuing the Seek. If that is impossible, IOS must perform action 2.</p>	Seek	(user's argument)	Set File Mask	(same as original)	Set Sector	(argument 0)	Read Home Address	(skip bit on)	TIC	(channel status word)				
Seek	(user's argument)														
Set File Mask	(same as original)														
Set Sector	(argument 0)														
Read Home Address	(skip bit on)														
TIC	(channel status word)														

Recovery Action Table – 3330/3350 (Continued)

Action	Explanation														
10A	<p>a. This is a multitrack operation. Increment the user's seek argument by 1.</p> <p>b. Continue the operation by executing:</p> <table border="0" style="margin-left: 2em;"> <tr> <td>Seek</td> <td>(argument from step a)</td> </tr> <tr> <td>Set File Mask</td> <td>(same as original)</td> </tr> <tr> <td>Set Sector</td> <td>(argument 0)</td> </tr> <tr> <td>Read Home Address</td> <td>(skip bit on)</td> </tr> <tr> <td>TIC</td> <td>(channel status word –8)</td> </tr> </table> <p>If the modified seek argument is not within the user's extent, IOS must supply the correct seek argument before issuing the Seek. If that is impossible, IOS must perform action 2.</p>	Seek	(argument from step a)	Set File Mask	(same as original)	Set Sector	(argument 0)	Read Home Address	(skip bit on)	TIC	(channel status word –8)				
Seek	(argument from step a)														
Set File Mask	(same as original)														
Set Sector	(argument 0)														
Read Home Address	(skip bit on)														
TIC	(channel status word –8)														
11	<p>a. Increment the user's seek argument by 1.</p> <p>b. Construct restart CCW 1.</p> <p>c. Complete the interrupted operation and continue the user's chain (if appropriate) by executing:</p> <table border="0" style="margin-left: 2em;"> <tr> <td>Seek</td> <td>(argument from step a)</td> </tr> <tr> <td>Set File Mask</td> <td>(same as original)</td> </tr> <tr> <td>Set Sector</td> <td>(argument 0)</td> </tr> <tr> <td>Search ID Equal</td> <td>(record 1)</td> </tr> <tr> <td>TIC*-8</td> <td></td> </tr> <tr> <td>Restart CCW 1</td> <td></td> </tr> <tr> <td>TIC</td> <td>(channel status word)</td> </tr> </table> <p>If the modified seek argument is not within the user's extent, IOS must supply the correct seek argument before issuing the Seek. If that is impossible, IOS must perform action 2.</p>	Seek	(argument from step a)	Set File Mask	(same as original)	Set Sector	(argument 0)	Search ID Equal	(record 1)	TIC*-8		Restart CCW 1		TIC	(channel status word)
Seek	(argument from step a)														
Set File Mask	(same as original)														
Set Sector	(argument 0)														
Search ID Equal	(record 1)														
TIC*-8															
Restart CCW 1															
TIC	(channel status word)														

Sense Bytes - 3340 and 3344

Sense information for the 3340 (24 bytes) identifies the conditions that caused the last unit check status to be generated. The sense information also provides secondary information for system error recovery and for diagnosing and isolating storage director and device malfunctions.

Sense Byte 0

Bit 0 Command Reject

Bit 0 is set by:

- An invalid command code
- An invalid command sequence
- An invalid or incomplete argument transferred by a control command
- A track formatted without a home address
- Issuing a write command with the Write Inhibit switch in the Read-Only position
- Attempting a format write command (other than Write Home Address or Write R0) on a defective track
- Issuing a write command that violates the file mask
- A record zero count field of a defective track that points to itself instead of the alternate track

Bit 1 Intervention Required

Bit 1 is set by:

- Addressing a drive that is not attached to the system
- Addressing a drive that is not ready
- Issuing a Diagnostic Write or Diagnostic Load command while an inline diagnostic is resident in control storage

Bit 2 Bus Out Parity Check

Bit 2 is set when a parity error is detected during transfer of a command from the channel to the 3880.

Bit 3 Equipment Check

Bit 3 is set when an unusual hardware condition occurs in the channel, storage director, or drive. The condition is further defined in sense bytes 7 through 23.

Bit 4 Data Check

Bit 4 is set when the storage director detects a data error in the information received from the drive. If byte 2, bit 1 (correctable) is also set, the data error is correctable and bytes 15 through 23 provide correction information. If the data error is uncorrectable, sense byte 7 defines the specific nature of the condition.

Bit 5 Overrun

Bit 5 is set when the storage director does not receive a response to a data request within a specified period of time or when a command overrun occurs. Format 0, message B is set on command overrun; format 0, message C is set on data overrun.

Detection of an overrun may cause requests for data from the channel to be terminated. When writing, the remaining portion of the record area is padded with a replicated data byte.

Sense Byte 0 (Continued)

**Bit 6
Track Condition Check**

Bit 6 is set when:

- Any read or search command (other than Search Home Address, Read Home Address, or Read R0) has been attempted on a defective track.
- A read or search command is to continue from an alternate track to the next highest track address due to multitrack operations.

When byte 1, bit 7 (operation incomplete) is set with this bit, it indicates a read, search, or update write on an overflow segment (other than the first segment).

**Bit 7
Seek Check**

Bit 7 is set when a seek operation is incomplete or when an incorrect physical address is encountered when reading a home address or count area.

Sense Byte 1

Bit 0 Permanent Error

Bit 0 is set when the external error recovery procedures have attempted the specified number of retry actions.

Bit 1 Invalid Track Format

Bit 1 is set when:

- Attempting to write data exceeding track capacity
- Detecting an index point in the gap that precedes a key or data field
- Detecting a missing home address area

Bit 2 End of Cylinder

Bit 2 is set when:

- A multitrack read or search operation continues past the end of the cylinder boundary.
- An overflow operation continues past the end of the cylinder boundary. Byte 1, bit 7 (operation incomplete) is also set.

Bit 3 Message to Operator

Bit 3 is set when there is a permanent failure in the alternate storage director or a state save operation in the reporting storage director. Byte 0, bit 3 (equipment check) is also set. A message is sent to the operator.

Bit 4 No Record Found

Bit 4 is set when the index point at the beginning of the selected logical track has been detected twice in the same CCW chain without an intervening read operation in the home address area or data area, or without an intervening write, sense, or control command.

Bit 5 File Protected

Bit 5 is set when:

- A seek command violates the file mask.
- A multitrack read or search operation violates the file mask.
- An overflow operation violates the seek portion of the file mask. Byte 1, bit 7 (operation incomplete) is also set.

Bit 6 Write Inhibited

Bit 6 is set when a write command is received for a drive that has the Write Inhibit switch in the Read-Only position. Byte 0, bit 0 (command reject) is also set.

Bit 7 Operation Incomplete

Bit 7 is set when one of the following conditions occurs during the processing of an overflow record.

- An overflow to a file protected boundary occurs. Byte 1, bit 5 (file protected) is also set.
- An overflow past the cylinder boundary occurs. Byte 1, bit 2 (end of cylinder) is also set.
- A correctable data check is detected in a data field other than the last segment. Byte 0, bit 4 (data check) and byte 2, bit 1 (correctable) are also set.
- An uncorrectable data check is detected in a data field in other than the first segment.
- A defective or alternate track condition is detected after the start of data transfer.

Sense byte 3 provides the restart command, and sense bytes 8 through 13 provide restart information.

Sense Byte 2

Bit 0
RPS Present Bit 0 is set when the RPS feature is installed in the 3340. (Bit 0 is always on for the 3344.)

Bit 1
Correctable Bit 1 is set when the data check condition indicated by byte 0, bit 4 (data check) is correctable.

Bit 2
Bit 2 is not used. It is set to zero.

Bit 3
Environmental Data Present Bit 3 is set when sense format 6 is presented. Sense format 6 is presented when:

- An error counter overflows (not overrun).
- The storage director is in force-error-log mode.
- A Read and Reset Buffered Log command is executed.

Bit 4
Drive Type Bit 4 indicates the type of drive: 0 = 3340, 1 = 3344.

Bits 5 Through 7
Data Storage Size Bits 5 through 7 identify the size and type of data storage on the selected drive.

DM Size	Bit 5	Bit 6	Bit 7
35 MB	0	0	1
70 MB*	0	1	0
Fixed Head **	1	1	0

* Posted on all 3344 logical addresses

** Posted only on this primary logical volume of the 3344

Sense Byte 3

Bits 0 Through 7
Restart Command Bits 0 through 7 are set when byte 1, bit 7 (operation incomplete) is set. These bits identify the type of operation in progress when the interrupt occurred. If the bits are set to 0000 0110, a read operation was in progress; if they are set to 0000 0101, a write operation was in progress.

When byte 1, bit 7 is zero, byte 3 is zero.

Sense Byte 4

Bits 0 Through 7
3340 Drive Identification Bits 0 through 7 identify the physical drive selected when a unit check occurred.

Bit	Drive	Bit	Drive
0	A	4	E
1	B	5	F
2	C	6	G
3	D	7	H

Bits 0 Through 7
3344 Drive Identification Bits 0-1 = String address Bit 4 = Not used
Bit 2 = Not used Bits 5-7 = Drive address
Bit 3 = Not used

Sense Byte 5

Bits 0 Through 7 Cylinder-Low Address

Bits 0 through 7 identify the low-order cylinder address of the most recent seek argument from the channel.

Bit 0 = Cylinder 128	Bit 4 = Cylinder 8
Bit 1 = Cylinder 64	Bit 5 = Cylinder 4
Bit 2 = Cylinder 32	Bit 6 = Cylinder 2
Bit 3 = Cylinder 16	Bit 7 = Cylinder 1

In conjunction with sense format 3 (microcode detected), byte 5 indicates the high-order byte of the instruction address register.

In conjunction with sense format 6, byte 5 indicates the number of diskette checks after an initial microcode load (IML) or a storage director-to-storage director communication failure.

Bit 0 = Communication failure during an IML	Bits 2-4 = Diskette check (seek errors)
Bit 1 = Not Used	Bits 5-7 = Diskette check (read errors)

Sense Byte 6

Bits 0 Through 7 Cylinder-High and Head Address

Bits 0 through 7 identify the high-order cylinder and head address of the most recent seek argument from the channel.

Bit 0 = Not used	Bit 4 = Logical track 8
Bit 1 = Cylinder 512	Bit 5 = Logical track 4
Bit 2 = Cylinder 256	Bit 6 = Logical track 2
Bit 3 = 0 for 3340 or 2048 for the 3344	Bit 7 = Logical track 1

Operations involving head switching update the head address bits (4 through 7) of this byte.

If an alternate track condition is detected and byte 1, bit 7 (operation incomplete) is posted during an overflow operation, byte 6 is set to the head address of the defective track and incremented by 1. The error recovery procedures use this byte to reconstruct the seek argument to continue the operation.

In conjunction with sense format 3 (microcode detected), byte 6 indicates the low-order byte of the instruction address register.

In conjunction with sense format 6, byte 6 identifies the storage director.

Sense Byte 7

Bits 0 Through 3 Format

Bits 0 through 3 specify the format of sense bytes 8 through 23 as follows:

0000 = Format 0 – program or system check

0001 = Format 1 – device equipment check (CE information)

0010 = Format 2 – storage director equipment check (CE information)

0011 = Format 3 – storage director control check (CE information)

0100 = Format 4 – data checks without displacement information (uncorrectable data checks)

0101 = Format 5 – data check with displacement information (correctable data checks)

0110 = Format 6 – usage statistics/overrun errors

Bits 4 Through 7 Message Code

Bits 4 through 7 describe the specific nature of the error conditions for each of the above formats. The message table that accompanies the format descriptions specifies the function of the message bits for the format.

Format 0 – Program or System Check

Format 0 is used when sense bytes 0 through 7 completely describe the error or unusual condition caused by a program or system error.

Bytes 8 Through 20

Bytes 8 through 20 are not used for 3340 or 3344 operations. They are set to 0.

Byte 21

Storage director ID.

Bytes 22 and 23

Skip Displacement

If a Sense command is chained from a successful Read Home Address command, bytes 22 and 23 contain the skip displacement bytes of the track. These bytes are not valid for other operations.

Message Table – Format 0

Sense Byte 7, Bits 4–7 =	Message Code	Message
0000	0	No message. No additional information required.
0001	1	An invalid command was issued to the 3880.
0010	2	An invalid command sequence was issued to the 3880.
0011	3	The CCW count was less than required for the command.
0100	4	An invalid data argument was used for the command.
0101	5	A Diagnostic Write command was issued when not permitted by the file mask.
0110	6	Retry status was presented but the channel did not indicate chaining.
0111	7	The command code of the CCW that was returned after a retry sequence did not match the command for which the retry was signaled.
1000	8	A Diagnostic Load command was issued but the IML device was not ready.
1001	9	A Diagnostic Load command was issued but the IML device had a permanent seek check.
1010	A	A Diagnostic Load command was issued but the IML device had a permanent read check.
1011	B	A command was received too late to be executed by the storage director and/or device.
1100	C	A response to a data request was not received by the storage director within a specified time.
1101	D	<ul style="list-style-type: none">• A single track command other than Read Home Address, Search Home Address, Read RO, Write Home Address, or Write RO, was executed on a defective track.• A multitrack command or overflow record operation attempted to switch from a defective track.• A multitrack or overflow operation other than Read Home Address, Read RO, or Search Home Address, switched to a defective track.• A defective track condition was detected after start of data transfer during processing of an overflow record
1110	E	A multitrack or overflow record operation attempted to switch from an alternate track.
1111	F	Not used.

Format 1 – Device Equipment Check

Format 1 is generated when:

- A device, device interface, or a controller equipment check is detected. Byte 0, bit 3 (equipment check) is also set.
- A permanent device seek check is detected. Byte 0, bit 3 (equipment check) and byte 1, bit 0 (permanent error) are also set. The message bits in sense byte 7 indicate a seek error.
- Error log information is off-loaded after a successful retried seek that occurred during error logging. Byte 3, bit 2 (environmental data present) is also set. The message bits in sense byte 7 indicate a seek error.
- Byte 8, bit 4 (on line) is off. Byte 0, bit 1 (intervention required) is also set.

Byte 8 Drive Status

When byte 19, bit 0 (set R/W) is on:

Bit 0 = Controller check
Bit 1 = Device interface check
Bit 2 = Drive check
Bit 3 = R/W check
Bit 4 = On line
Bit 5 = Data module attention
Bit 6 = Busy
Bit 7 = Seek complete, search sector,
or pad complete

When byte 19, bit 0 is off:

Bit 0 = Controller check
Bit 1 = Device interface check
Bit 2 = Drive check
Bit 3 = R/W check
Bit 4 = On line
Bit 5 = Initialize write sense
Bit 6 = Index mark
Bit 7 = Active track

Byte 9 Drive Checks

Bit 0 = DM loaded switch latched
Bit 1 = Sector compare check
Bit 2 = Motor-at-speed switch latched
Bit 3 = Air/belt switch latched

Bit 4 = Write enable
Bit 5 = FH DM size 4
Bit 6 = DM size 2 (70 MB)
Bit 7 = DM size 1 (35 MB)

Byte 10 DM Sequence Control

Bit 0 = DM size check
Bit 1 = DM latch 4
Bit 2 = DM latch 2
Bit 3 = DM latch 1

Bit 4 = Check latch
Bit 5 = DM sequence check latched
Bit 6 = Bias disable switch
Bit 7 = Odd physical track

Byte 11 Load Switch Status

Bit 0 = Drive start switch
Bit 1 = DM present switch
Bit 2 = Cover locked switch
Bit 3 = DM unloaded switch

Bit 4 = DM loaded switch
Bit 5 = Air/belt switch
Bit 6 = Carriage home
Bit 7 = Motor-at-speed switch

Byte 12 R/W Safety

Bit 0 = Multiple-head select check
Bit 1 = Capable/enable check
Bit 2 = Write overrun
Bit 3 = Index check

Bit 4 = R/W interlock check
Bit 5 = Control check
Bit 6 = Write transition check
Bit 7 = Write current during read check

Format 1 (Continued)

Byte 13 Control Interface Check

When byte 0, bit 7 (seek check) is off, bits 0 through 3 contain the control interface bus out value for message code C, and bits 4 through 7 contain the expected drive status for messages 1, 3, 5, 6, 7, 8, and 9.

When byte 0, bit 7 is on, byte 13 indicates the previous seek address and the logical cylinder and head address for 3340s, or the physical cylinder and track address for 3344s.

3340

Bit 0 = Not used
Bit 1 = 512
Bit 2 = 256
Bit 3 = Not used
Bit 4 = 8
Bit 5 = 4
Bit 6 = 2
Bit 7 = 1

3344

Bit 0 = 512
Bit 1 = 256
Bit 2 = 32
Bit 3 = 16
Bit 4 = 8
Bit 5 = 4
Bit 6 = 2
Bit 7 = 1

Byte 14 Control Interface Bus In

When byte 0, bit 7 (seek check) is off, byte 14 contains the control interface bus in for message codes 1, 3, 5, 6, 7, 8, and 9 and for message code 2 if byte 18 equals '01', '03', '05', or '06'.

When byte 0, bit 7 is on, byte 14 indicates the high-logical cylinder address and the head address for 3340s and the high-physical cylinder and physical track address for 3344s.

3340

Bit 0 = Not used
Bit 1 = 512
Bit 2 = 256
Bit 3 = Not used
Bit 4 = 8
Bit 5 = 4
Bit 6 = 2
Bit 7 = 1

3344

Bit 0 = 512
Bit 1 = 256
Bit 2 = 32
Bit 3 = 16
Bit 4 = 8
Bit 5 = 4
Bit 6 = 2
Bit 7 = 1

Byte 15 Control Interface Tag Bus

Byte 15 contains the control interface tag bus value for message codes 1, 3, 5, 6, 7, 8, and 9.

Byte 16 Access Status

Bit 0 = Access time out
Bit 1 = Overshoot check
Bit 2 = Servo off-track check
Bit 3 = Track crossing

Bit 4 = Servo latch
Bit 5 = Linear mode latch
Bit 6 = Control latch
Bit 7 = Wait latch

Byte 17 Controller Checks

Bit 0 = PLO check
Bit 1 = No PLO input check
Bit 2 = SERDES check
Bit 3 = Gap counter check

Bit 4 = Write data check
Bit 5 = Monitor check
Bit 6 = ECC check
Bit 7 = ECC zero detected

Format 1 (continued)

Byte 18 Microcode Detected Errors

Bits 0 through 3 are not used. Bits 4 through 7 indicate the following error conditions:

- 0000 = Not used
- 0001 = Tag Valid indication missing on a read or write operation
- 0010 = Normal End or Check End indication missing on a read, write, or ECC operation
- 0011 = No response from the controller on a control operation
- 0100 = A time out occurred while waiting for index or active track
- 0101 = ECC hardware check
- 0110 = Either more than one controller was selected or no controller was selected.
- 0111 = Preselection check
- 1000 = Repetitive command overruns on gap 1 operations
- 1001 = Busy missing after seek start was issued
- 1010 = Incorrect drive selected
- 1011 = Not used
- 1100 = Invalid Check End indication
- 1101 = After a successful comparison, the physical address did not compare
- 1110 = Active CTL-I bus
- 1111 = Attention check

Byte 19 Status

- Bit 0 = Set R/W on
- Bits 1-4 = Not used
- Bit 5 = Low-gain error
- Bit 6 = Not used
- Bit 7 = Fixed head feature

Byte 20 Interface Checks

When byte 0, bit 7 is off, the bits in byte 20 have the following meaning:

- Bit 0 = Control interface tag bus parity check
- Bit 1 = Control interface bus out parity check
- Bit 2 = Drive selection check
- Bit 3 = Device bus in parity check
- Bit 4 = Control interface bus in parity check
- Bit 5 = Initialize write failure
- Bit 6 = Device bus out parity check
- Bit 7 = Device tag parity check

When byte 0, bit 7 is on and message A is indicated in format 1, byte 20 contains the present seek address and low-logical cylinder address for 3340s, or the low-physical cylinder address for 3344s. If the fixed head feature is installed, bits 0 through 6 are zero; and bit 7, when on, = '64'.

Format 1 (Continued)

Byte 21

When byte 0, bit 7 (seek check) is off, byte 21 contains the physical drive identification for 3344 attachment and is not used for 3340 attachment.

When byte 0, bit 7 is on and message A is indicated in format 1, byte 21 contains the high-logical cylinder address and the head address for 3340s; and contains the high-physical cylinder and physical track addresses for 3344s. If the fixed head feature is installed, bits 0 and 1 are set to 1.

3340

Bit 0 = Not used
Bit 1 = 512
Bit 2 = 256
Bit 3 = Not used
Bit 4 = 8
Bit 5 = 4
Bit 6 = 2
Bit 7 = 1

3344

Bit 0 = 512
Bit 1 = 256
Bit 2 = 32
Bit 3 = 16
Bit 4 = 8
Bit 5 = 4
Bit 6 = 2
Bit 7 = 1

Bytes 22 and 23

Bytes 22 and 23 contain the symptom code.

Message Table – Format 1

Sense Byte 7, Bits 4–7 =	Message Code	Message
0000	0	No message. No additional information required.
0001	1	Transmit target error
0010	2	Microcode detected error
0011	3	Transmit fixed-head error (3340) or transmit difference high error (3344)
0100	4	Sync-out timing error
0101	5	Unexpected drive status at initial selection
0110	6	Transmit cylinder address error (string switch only)
0111	7	Transmit head error
1000	8	Transmit difference error
1001	9	Unexpected drive status
1010	A	Seek error
1011	B	Seek incomplete on retry
1100	C	No interrupt from drive
1101	D	Reorientation check
1110	E	Unable to determine data module type during initial selection (3340 only)
1111	F	Not used

Format 2 – Storage Director Equipment Check

Format 2 is generated when the microcode detects a storage director error condition.

Byte 8	Contents of the transfer complete status (XCS) register.
Byte 9	Contents of the transfer error status (XES) register.
Byte 10	Contents of the check register.
Byte 11	Contents of the channel transfer control (CXC) register.
Byte 12	Contents of channel control 2 register.
Byte 13	Contents of the device bus out (DBO) register
Byte 14	Contents of the device bus in (DBI) register
Byte 15	Contents of the device tag out (DTO) register
Byte 16	Contents of the device tag gate (DTG) register
Byte 17	Contents of the device tag in (DTI) register
Byte 18	Contents of channel status 2 register
Byte 19	Not used
Byte 20	Reserved for microcode detected check 2 conditions.
Byte 21	Storage director ID
Bytes 22 and 23	Symptom code

Message Table – Format 2

Sense Byte 7, Bits 4-7 =	Message Code	Message
0000-0111	0-7	Reserved for other types of storage control units
1000	8	No message. No additional information required.
1001	9	Selective reset occurred while a drive was selected.
1010	A	Failure to latch the First Sync In line.
1011-1111	B-F	Reserved

Format 3 – Storage Director Control Check (Hardware Detected)

Format 3 is generated to provide sense information for a failing storage director that requires a reset procedure for recovery.

Byte 8	Contents of FRU register 2 (bit 4 = 0)
Byte 9	Contents of check register 1
Byte 10	Contents of check register 2
Byte 11	Contents of check register 3
Byte 12	Not used
Byte 13	Not used
Byte 14	Not used
Byte 15	Contents of FRU register 3
Byte 16	Contents of FRU register 4
Byte 17	Not used
Byte 18	Not used
Byte 19	Not used
Byte 20	Not used
Byte 21	Storage director ID
Bytes 22 and 23	Symptom code

Message Table – Format 3

Sense Byte 7, Bits 4-7 =	Message Code	Message
0000-0111	1-7	Reserved for other types of storage control units
1000	8	No message. No additional information required.
1001-1111	9-F	Reserved

Format 3 – Storage Director Control Check (Microcode Detected)

Byte 8	Not used
Byte 9	Contents of the transfer error status (XES) register
Byte 10	Contents of the check register
Byte 11	Contents of the condition register 0 (CRO) register
Byte 12	Contents of the channel status 2 (CS2) register
Byte 13	Contents of the channel control 1 (CC1) register
Byte 14	Contents of the channel control 2 (CC2) register
Byte 15	Contents of the channel status 1 (CS1) register
Byte 16	Contents of the channel status 3 (CS3) register
Byte 17	Contents of the channel transfer control (CXC) register
Byte 18	Contents of the channel bus out (CBO) register
Byte 19	Contents of the channel bus in (CBI) register
Byte 20	Interrupt level
Byte 21	Storage director ID
Bytes 22 and 23	Symptom code

Message Table – Format 3

Sense Bits 7, Bits 4-7 =	Message Code	Message
0000-1000	0-8	Reserved
1001	9	Channel check 1 or storage director timeout
1010	A	Trace table saved in this storage director
1011-1111	B-F	Reserved

Format 4 – Data Check Without Displacement Information

Format 4 is generated when:

- Errors that are not correctable by the ECC are detected after retry has been unsuccessful. Byte 1, bit 0 (permanent error) is also set.
- Error log information is off-loaded after an ECC uncorrectable error occurred during error logging. The information is recovered through use of command retry. Byte 2, bit 3 (environmental data present) is also set.

**Bytes 8 Through 12
Count ID**

Bytes 8 through 12 contain the record ID obtained from the count field of the record in which the error occurred. These bytes are unreliable if the message code in byte 7 is 0, 1, 4, or 5. Byte 12 is unreliable after a Space Count command.

**Byte 13
Sector Number**

Byte 13 contains the sector number.

Bytes 14 Through 21

Bytes 14 through 21 are not used.

Bytes 22 and 23

Bytes 22 and 23 contain the symptom code.

Message Table – Format 4

Sense Byte 7, Bits 4-7 =	Message Code	Message
0000	0	An error occurred in the home address area and could not be corrected by the ECC.
0001	1	An error occurred in the count area and could not be corrected by the ECC.
0010	2	An error occurred in the key area and could not be corrected by the ECC.
0011	3	An error occurred in the data area and could not be corrected by the ECC.
0100	4	Data synchronization on the home address area was unsuccessful.
0101	5	Data synchronization on the count area was unsuccessful.
0110	6	Data synchronization on the key area was unsuccessful.
0111	7	Data synchronization on the data area was unsuccessful.
1000-1111	8-F	Not used.

Format 5 – Data Checks With Displacement Information

Format 5 is generated when:

- Data checks that are correctable by the ECC are detected in the data area of a record.
- Data checks in data areas that are not correctable by the ECC were successfully retried but the file mask specified PCI fetch mode.
- Error log information is off-loaded after an ECC correctable error occurred during error logging.
- Data checks are detected while processing a Read Multiple Count, Key, and Data command.

Bytes 8 Through 12 Count ID

Bytes 8 through 12 contain the record ID obtained from the count field of the record in which the error occurred. These bytes are unreliable if the message code in byte 7 is 0, 1, 4, or 5. Byte 12 is unreliable after a Space Count command.

Byte 13 Sector Number

Byte 13 contains the sector number.

Byte 14

Byte 14 is not used.

Bytes 15 Through 17

Bytes 15 through 17 contain the restart displacement.

Bytes 18 and 19

Bytes 18 and 19 contain the error displacement.

Bytes 20 Through 23

Bytes 20 through 23 contain the error pattern.

Message Table – Format 5

Sense Byte 7, Bits 4-7 =	Message Code	Message
0000-0010	0-2	Not used
0011	3	Error in the data area
0100-1111	4-F	Not used

Format 6 – Usage Statistics/Overrun Errors

Format 6 is generated when:

- A Read and Reset Buffered Log command is executed.
- Usage/error statistics require off-loading due to counter overflow.
- When an overrun occurs, the appropriate counter is incremented. When it reaches 'FF', unit check is presented to the next Start I/O instruction received.

Bytes 8 Through 11 Bytes Read or Searched

Bytes 8 through 11 contain an accumulated count of the number of bytes processed by the storage director during read and search operations. (Only key and data area bytes are counted.) Bytes processed during retry operations are not counted.

Bytes 12 Through 15

Bytes 12 through 15 are not used.

Bytes 16 and 17 Number of Seeks

Bytes 16 and 17 contain the number of seek commands processed by the storage director.

Byte 18 Channel Select

Byte 18 specifies which channel the information in bytes 20 through 23 pertain to.

If bits 0 and 1 are:

00 = Channels A and B

10 = Channels C and D

Bits 2 through 7 are not used.

Byte 19

Byte 19 is not used.

Byte 20 Command Overruns Channel A

Byte 20 contains the number of command overruns that occurred on channel A if bit 0 is 0, or on channel C if byte 18, bit 0 is 1.

Byte 21 Data Overruns Channel A

Byte 21 contains the number of data overruns that occurred on channel A if byte 18, bit 0 is 0, or on channel C if byte 18, bit 0 is 1.

Byte 22 Command Overruns Channel B

Byte 22 contains the number of command overruns that occurred on channel B if byte 18, bit 0 is 0, or on channel D if byte 18, bit 0 is 1.

Byte 23 Data Overruns Channel B

Byte 23 contains the number of data overruns that occurred on channel B if byte 18, bit 0 is 0, or on channel D if byte 18, bit 0 is 1.

Message Table – Format 6

Sense Byte 7, Bits 4–7 =	Message Code	Message
0000-0111	0–7	Not used
1000	8	3880 offload
1001-1111	9–F	Not used

Error Condition Table – 3340 and 3344

Byte	Bit	Name	General Description	Action	Logged
0	0	Command reject	Programming error	1	No
0 1	0 6	Command reject Write inhibited	A write command received with the Write Inhibit switch in the Read-Only position	1	No
0	1	Intervention required	Drive offline, not ready, CE mode, or data module incompatibility such as a 3348-70F installed on a drive that does not have the fixed head feature	1	Yes
0	2	Bus out parity	Bus out parity error	3	Yes
0	3	Equipment check	Equipment malfunction	4	Yes
0 1	3 3	Equipment check Message to operator	Permanent equipment malfunction of the alternate storage director or state save operation in the reporting storage director.	4B	Yes
0	4	Data check	Data check in home address, count area, or key area; or uncorrectable data check in data area	4	Yes
0 1 2	4 7 1	Data check Operation incomplete Correctable	Correctable data check in the data area of an overflow segment, but not the last segment	8	Yes
0 2 1 1 0	4 1 7 6	Data check Correctable Operation incomplete Track condition check	Correctable data check in the data area of an overflow segment (not the last segment) of an alternate track	8A	Yes
0 2	4 1	Data check Correctable	Correctable data check in a non-multitrack data area or data area of the last overflow segment	7	Yes
0	5	Overrun	Command retry exhausted on a service overrun	4	Yes
0	6	Track condition check	Non-home address or record 0 commands for a defective track or any multitrack commands switching from a known alternate or defective track	5	No
0 1	6 7	Track condition check Operation incomplete	Switching from alternate track during overflow record processing or switching to a defective track during overflow record processing	9	No
0	7	Seek check	Seek incomplete or incorrect physical address when reading home address or count area	6	Yes
1	1	Invalid track format	Track capacity exceeded	2	No
1	2	End of cylinder	Cylinder boundary detected during a basic multitrack operation	10	No
1 1	2 7	End of cylinder Operation incomplete	Cylinder boundary detected during a basic overflow operation	11	No
1	4	No record found	Programming error or expected programming error condition. The search data does not exist on that track.	2	No
1	5	File protected	The seek command or read/search multitrack operation violated the file mask.	12	No
1 1	5 7	File protected Operation incomplete	A read or write overflow operation violated the file mask.	13	No
2	3	Environmental data present	Statistical usage/error log information is present.	3	Yes

Recovery Action Table – 3340 and 3344

Action	Explanation												
1	Print console error message.												
2	Exit with programming error or unusual condition indication.												
3	a. Repeat the operation once. b. If the error condition persists, perform action 1.												
4	a. Repeat the operation. b. If the error condition persists after ten retries, perform action 1.												
4A	<p>An uncorrectable data check has occurred during a Read Multiple CKD command. The restart chain must orient on the count field prior to the record in error.</p> <p>Determine the quantity of bytes read (CCW count minus CSW residual; if data chaining was indicated, the counts of the data-chained Read Multiple CKD CCWs up to the one in error must be accumulated). Using this count and starting with the data pointed to by the Read Multiple CKD (or start of the data chain), scan through main storage and locate the count fields of records successfully read. Obtain the length of each record from its count field. Develop a pointer to the first byte following the last record successfully read (to be used as the data address in the restart CCW).</p> <p>For format 4 messages 1, 2, or 3, the field in error will have entered main storage; for message 5, 6, or 7, the field will not have entered main storage.</p> <p>Restart the operation by executing:</p> <table border="0"> <tr> <td>Seek</td> <td>(same as original, see note below)</td> </tr> <tr> <td>Set File Mask</td> <td>(same as original)</td> </tr> <tr> <td>Search ID Equal</td> <td>(CCHHR of last record successfully read as determined by the previous calculations in this recovery action)</td> </tr> <tr> <td>TIC*-8</td> <td></td> </tr> <tr> <td>Read Multiple CKD</td> <td>(data address as determined above in this action count = CSW residual, flags are the same as the interrupted CCW. If the record still cannot be read after ten retries, perform action 1.)</td> </tr> <tr> <td>TIC</td> <td>(channel status word)</td> </tr> </table>	Seek	(same as original, see note below)	Set File Mask	(same as original)	Search ID Equal	(CCHHR of last record successfully read as determined by the previous calculations in this recovery action)	TIC*-8		Read Multiple CKD	(data address as determined above in this action count = CSW residual, flags are the same as the interrupted CCW. If the record still cannot be read after ten retries, perform action 1.)	TIC	(channel status word)
Seek	(same as original, see note below)												
Set File Mask	(same as original)												
Search ID Equal	(CCHHR of last record successfully read as determined by the previous calculations in this recovery action)												
TIC*-8													
Read Multiple CKD	(data address as determined above in this action count = CSW residual, flags are the same as the interrupted CCW. If the record still cannot be read after ten retries, perform action 1.)												
TIC	(channel status word)												
4B	a. Print console error message. b. Repeat the operation once. c. If error condition persists, perform action 1.												
5	a. If this is a defective track, perform action 5A. b. Use the address of the defective track plus 1 in a Seek command. The defective track address can be found in the ID area of record 0 count area. c. Resume operation after searching to the desired track position.												
5A	a. Use the address of the alternate track in a Seek command. The alternate track address can be found in the ID area of the record 0 area. b. Resume operation after searching to the desired track position.												
6	a. Issue a Recalibrate command. b. Seek to the original address. c. Perform action 4.												

Note: Cylinder bytes and the high-order head bytes are obtained from the user, not from the sense bytes. The low-order head byte is obtained from sense byte 6, bits 3 through 7.

Recovery Action Table — 3340 and 3344 (Continued)

Action	Explanation														
7	<p>a. Perform the error correction function.</p> <p>b. Examine bit 7 of the file mask. If off, go to step c. If on, indicate that the data has been corrected. (The user is operating in PCI fetch mode and must supply the restart recovery action.)</p> <p>c. Examine the interrupted CCW (CSW-8). If the command is a Read Multiple CKD, perform action 7B; otherwise, continue. If the user's chain is not completed, examine the next non-TIC command. If bit 3 is on (count area), go to step d; if off, perform action 7A.</p> <p>If data chaining is indicated in the interrupted CCW, the preceding test must be executed on the first non-TIC CSW after the last CCW in the data chain.</p> <p>d. Continue the user's chain (if appropriate) by executing:</p> <table border="0" style="margin-left: 2em;"> <tr> <td>Seek</td> <td>(same as original, see note below)</td> </tr> <tr> <td>Set File Mask</td> <td>(same as original)</td> </tr> <tr> <td>Read Home Address</td> <td>(skip bit is on)</td> </tr> <tr> <td>Search ID Equal</td> <td>(CCHHR from sense bytes 8 through 12)</td> </tr> <tr> <td>TIC*-8</td> <td></td> </tr> <tr> <td>TIC</td> <td>(channel status word)</td> </tr> </table>	Seek	(same as original, see note below)	Set File Mask	(same as original)	Read Home Address	(skip bit is on)	Search ID Equal	(CCHHR from sense bytes 8 through 12)	TIC*-8		TIC	(channel status word)		
Seek	(same as original, see note below)														
Set File Mask	(same as original)														
Read Home Address	(skip bit is on)														
Search ID Equal	(CCHHR from sense bytes 8 through 12)														
TIC*-8															
TIC	(channel status word)														
7A	<p>Continue the user's chain by executing:</p> <table border="0" style="margin-left: 2em;"> <tr> <td>Seek</td> <td>(same as original, see note below)</td> </tr> <tr> <td>Set File Mask</td> <td>(same as original)</td> </tr> <tr> <td>Read Home Address</td> <td>(skip bit is on)</td> </tr> <tr> <td>Search ID Equal</td> <td>(CCHHR from sense bytes 8 through 12)</td> </tr> <tr> <td>TIC*-8</td> <td></td> </tr> <tr> <td>Read Count</td> <td>(skip bit is on)</td> </tr> <tr> <td>TIC</td> <td>(channel status word)</td> </tr> </table>	Seek	(same as original, see note below)	Set File Mask	(same as original)	Read Home Address	(skip bit is on)	Search ID Equal	(CCHHR from sense bytes 8 through 12)	TIC*-8		Read Count	(skip bit is on)	TIC	(channel status word)
Seek	(same as original, see note below)														
Set File Mask	(same as original)														
Read Home Address	(skip bit is on)														
Search ID Equal	(CCHHR from sense bytes 8 through 12)														
TIC*-8															
Read Count	(skip bit is on)														
TIC	(channel status word)														
7B	<p>This action is used to restart a Read Multiple CKD data recovery process after a correctable data check has been processed. Reconstruct the Read Multiple CKD as follows:</p> <p>a. Set the command code to '5E'.</p> <p>b. The data address is that of the interrupted CCW, plus the count of the CCW, minus the CSW residual count.</p> <p>If data chaining was used with the command, the procedure outlined in the restart CCW 2 section, steps 2 and 4, must be used to account for the actual amount of data transferred.</p> <p>c. The flags (except PCI) are those of the interrupted CCW.</p> <p>d. The count is the CSW residual count. (If data chaining was used, see the note under b and use step 2.)</p> <p>Restart the operation by executing:</p> <table border="0" style="margin-left: 2em;"> <tr> <td>Seek</td> <td>(see note below)</td> </tr> <tr> <td>Set File Mask</td> <td>(same as original)</td> </tr> <tr> <td>Read Home Address</td> <td>(skip bit is on)</td> </tr> <tr> <td>Search ID Equal</td> <td>(CCHHR from sense bytes 8 through 12)</td> </tr> <tr> <td>TIC*-8</td> <td></td> </tr> <tr> <td>Read Multiple CKD</td> <td>(from step a)</td> </tr> <tr> <td>TIC</td> <td>(to CSW if user's chain has not been completed)</td> </tr> </table>	Seek	(see note below)	Set File Mask	(same as original)	Read Home Address	(skip bit is on)	Search ID Equal	(CCHHR from sense bytes 8 through 12)	TIC*-8		Read Multiple CKD	(from step a)	TIC	(to CSW if user's chain has not been completed)
Seek	(see note below)														
Set File Mask	(same as original)														
Read Home Address	(skip bit is on)														
Search ID Equal	(CCHHR from sense bytes 8 through 12)														
TIC*-8															
Read Multiple CKD	(from step a)														
TIC	(to CSW if user's chain has not been completed)														

Note: Cylinder bytes and the high-order head bytes are obtained from the user, not from the sense bytes. The low-order head byte is obtained from sense byte 6, bits 3 through 7.

Recovery Action Table – 3340 and 3344 (Continued)

Action	Explanation														
8	<p>a. Perform the error correction function.</p> <p>b. Examine bit 7 of the file mask (PCI). If off, go to step c. If on, indicate that the data has been corrected. The user is operating in PCI fetch mode and must supply the restart recovery action.</p> <p>c. Increment the seek argument by 1 (see note below).</p> <p>d. Construct restart CCW 2.</p> <p>e. Complete the interrupted operation and continue the user's chain (if appropriate) by executing:</p> <table border="0"> <tr> <td>Seek</td> <td>(argument from step c)</td> </tr> <tr> <td>Set File Mask</td> <td>(same as original)</td> </tr> <tr> <td>Set Sector</td> <td>(argument 0)</td> </tr> <tr> <td>Search ID Equal</td> <td>(record 1)</td> </tr> <tr> <td>TIC*-8</td> <td></td> </tr> <tr> <td>Restart CCW 2</td> <td></td> </tr> <tr> <td>TIC</td> <td>(channel status word)</td> </tr> </table> <p>If the modified seek argument is not within the user's extent, IOS must supply the correct seek argument before issuing the Seek command. If that is impossible, IOS must perform action 2.</p>	Seek	(argument from step c)	Set File Mask	(same as original)	Set Sector	(argument 0)	Search ID Equal	(record 1)	TIC*-8		Restart CCW 2		TIC	(channel status word)
Seek	(argument from step c)														
Set File Mask	(same as original)														
Set Sector	(argument 0)														
Search ID Equal	(record 1)														
TIC*-8															
Restart CCW 2															
TIC	(channel status word)														
8A	<p>a. Perform the error correction function.</p> <p>b. Examine bit 7 of the file mask (PCI). If off, go to step c. If on, indicate that the data has been corrected. The user is operating in PCI fetch mode and must supply the restart recovery action.</p> <p>c. Use the address of the defective track plus 1 in the Seek command.</p> <p>d. Construct restart CCW 2.</p> <p>e. Complete the interrupted operation and continue the user's chain (if appropriate) by executing:</p> <table border="0"> <tr> <td>Seek</td> <td>(argument from step c, see note below)</td> </tr> <tr> <td>Set File Mask</td> <td>(same as original)</td> </tr> <tr> <td>Set Sector</td> <td>(argument 0)</td> </tr> <tr> <td>Search ID Equal</td> <td>(record 1)</td> </tr> <tr> <td>TIC*-8</td> <td></td> </tr> <tr> <td>Restart CCW 2</td> <td></td> </tr> <tr> <td>TIC</td> <td>(pointer established while constructing restart CCW 2 + 8.)</td> </tr> </table> <p>If the modified seek argument is not within the user's extent, IOS must supply the correct seek argument before issuing the Seek command. If that is impossible, IOS must perform action 2.</p>	Seek	(argument from step c, see note below)	Set File Mask	(same as original)	Set Sector	(argument 0)	Search ID Equal	(record 1)	TIC*-8		Restart CCW 2		TIC	(pointer established while constructing restart CCW 2 + 8.)
Seek	(argument from step c, see note below)														
Set File Mask	(same as original)														
Set Sector	(argument 0)														
Search ID Equal	(record 1)														
TIC*-8															
Restart CCW 2															
TIC	(pointer established while constructing restart CCW 2 + 8.)														

Note: Cylinder bytes and the high-order head bytes are obtained from the user, not from the sense bytes. The low-order head byte is obtained from sense byte 6, bits 3 through 7.

Recovery Action Table — 3340 and 3344 (Continued)

Action	Explanation
9	<p>a. If this is a defective track, perform action 9A.</p> <p>b. Use the address of the defective track plus 1 in a Seek command and use the following CCW chain to resume the operation.</p> <p>Seek Set File Mask (same as original) Set Sector (argument 0) Search ID Equal (record 1) TIC*-8 Restart CCW 1 TIC (channel status word)</p> <p>If the modified seek argument is not within the user's extent, IOS must supply the correct seek argument before issuing the Seek command. If that is impossible, IOS must perform action 2.</p>
9A	<p>a. Use the address of the alternate track in a Seek command in the following CCW chain.</p> <p>Seek Set File Mask (inhibit seeks) Set Sector (argument 0) Search ID Equal (record 1) TIC*-8 Restart CCW 1 TIC (channel status word)</p>
10	<p>a. Increment the cylinder address of the user's seek argument by 1. Reset the head address.</p> <p>b. Continue the operation by executing the following:</p> <p>Seek (argument from step a) Set File Mask (same as original) Set Sector (argument 0) Read Home Address (skip bit is on) TIC (channel status word minus 8)</p> <p>If the modified seek argument is not within the user's extent, IOS must supply the correct seek argument before issuing the Seek command. If that is impossible, IOS must perform action 2.</p>
11	<p>a. Increment the cylinder address of the user's seek argument by 1. Reset the head address.</p> <p>b. Construct restart CCW 1.</p> <p>c. Complete the interrupted operation and continue the user's chain (if appropriate) by executing:</p> <p>Seek (argument from step a) Set File Mask (same as original) Set Sector (argument 0) Search ID Equal (record 1) TIC*-8 Restart CCW 1 TIC (channel status word)</p> <p>If the modified seek argument is not within the user's extent, IOS must supply the correct seek argument before issuing the Seek. If that is impossible, IOS must perform action 2.</p>

Recovery Action Table – 3340 and 3344 (Continued)

Action	Explanation														
12	<p>a. Determine if the interrupted command is a seek. If it is, go to step b. If not, perform action 12A.</p> <p>b. Complete the interrupted operation and continue the user's chain (if appropriate) by executing:</p> <table border="0" style="margin-left: 20px;"> <tr> <td>Seek</td> <td>(same as original, see note below)</td> </tr> <tr> <td>Set File Mask</td> <td>(same as original)</td> </tr> <tr> <td>Set Sector</td> <td>(argument 0)</td> </tr> <tr> <td>Read Home Address</td> <td>(skip bit is on)</td> </tr> <tr> <td>TIC</td> <td>(channel status word)</td> </tr> </table> <p>If the modified seek argument is not within the user's extent, IOS must supply the correct seek argument before issuing the Seek. If that is impossible, IOS must perform action 2.</p>	Seek	(same as original, see note below)	Set File Mask	(same as original)	Set Sector	(argument 0)	Read Home Address	(skip bit is on)	TIC	(channel status word)				
Seek	(same as original, see note below)														
Set File Mask	(same as original)														
Set Sector	(argument 0)														
Read Home Address	(skip bit is on)														
TIC	(channel status word)														
12A	<p>a. This is a multitrack operation. Increment the user's seek argument by 1 (see note below).</p> <p>b. Complete the interrupted operation and continue the user's chain (if appropriate) by executing:</p> <table border="0" style="margin-left: 20px;"> <tr> <td>Seek</td> <td>(argument from step a)</td> </tr> <tr> <td>Set File Mask</td> <td>(same as original)</td> </tr> <tr> <td>Set Sector</td> <td>(argument 0)</td> </tr> <tr> <td>Read Home Address</td> <td>(skip bit is on)</td> </tr> <tr> <td>TIC</td> <td>(channel status word minus 8)</td> </tr> </table> <p>If the modified seek argument is not within the user's extent, IOS must supply the correct seek argument before issuing the Seek. If that is impossible, IOS must perform action 2.</p>	Seek	(argument from step a)	Set File Mask	(same as original)	Set Sector	(argument 0)	Read Home Address	(skip bit is on)	TIC	(channel status word minus 8)				
Seek	(argument from step a)														
Set File Mask	(same as original)														
Set Sector	(argument 0)														
Read Home Address	(skip bit is on)														
TIC	(channel status word minus 8)														
13	<p>a. Increment the user's seek argument by 1.</p> <p>b. Construct the restart CCW 1.</p> <p>c. Complete the interrupted operation and continue the user's chain (if appropriate) by executing:</p> <table border="0" style="margin-left: 20px;"> <tr> <td>Seek</td> <td>(argument from step a)</td> </tr> <tr> <td>Set File Mask</td> <td>(same as original)</td> </tr> <tr> <td>Set Sector</td> <td>(argument 0)</td> </tr> <tr> <td>Search ID Equal</td> <td>(record 1)</td> </tr> <tr> <td>TIC*-8</td> <td></td> </tr> <tr> <td>Restart CCW 1</td> <td></td> </tr> <tr> <td>TIC</td> <td>(channel status word)</td> </tr> </table> <p>If the modified seek argument is not within the user's extent, IOS must supply the correct seek argument before issuing the Seek. If that is impossible, IOS must perform action 2.</p>	Seek	(argument from step a)	Set File Mask	(same as original)	Set Sector	(argument 0)	Search ID Equal	(record 1)	TIC*-8		Restart CCW 1		TIC	(channel status word)
Seek	(argument from step a)														
Set File Mask	(same as original)														
Set Sector	(argument 0)														
Search ID Equal	(record 1)														
TIC*-8															
Restart CCW 1															
TIC	(channel status word)														

Note: *Cylinder bytes and the high-order head bytes are obtained from the user, not from the sense bytes. The low-order head byte is obtained from sense byte 6, bits 3 through 7.*

Operator Panel

The operator panel consists of switches and indicators that are used to monitor and control the functions of the 3880 and its attached disk storage.

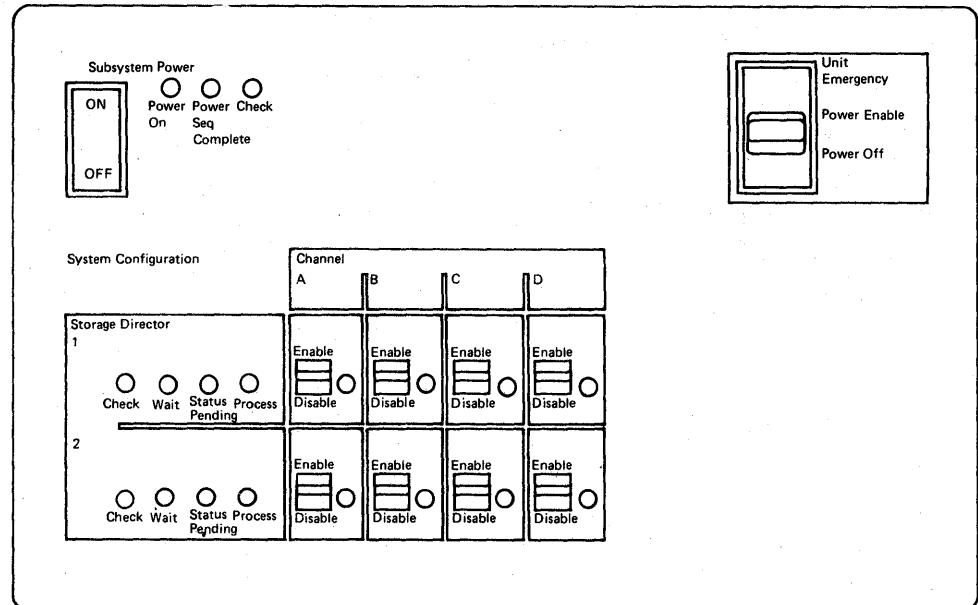

Subsystem Power

On/Off switch provides manual control of subsystem power.

Power On indicates that power is applied to the subsystem.

Power Seq Complete indicates that a signal has been sent to the processor verifying that power sequencing for the subsystem is completed.

Check indicates that there is a problem in the power circuitry.

System Configuration

Check indicates that there is a malfunction in the associated storage director.

Wait indicates that this storage director is in the wait state and is not processing any information.

Process indicates that the associated storage director is processing information.

Status Pending indicates that the associated storage director has status pending or is in a contingent connection.

Enable/Disable switches must be in the Enable position before the associated storage director is available to the channel. (The switch configuration shown is for a 3880 with the two-channel switch pair, additional feature installed.)

Unit Emergency

Power Enable/Power Off switch is provided for operator control of subsystem power in case of an emergency.

Appendix – Device Addressing

The I/O addresses of the storage directors and drives are indicated by an eight bit binary number in an I/O instruction. The addresses consist of three parts: the storage director address, the address of the controller, and the drive address. The complete I/O address is specified in bytes 2 and 3 of the I/O instruction. Each storage director in the 3880 may have a maximum of 64 drive addresses assigned to it. Configurations requiring a maximum of 8, 16, or 32 logical device addresses are subsets of this maximum configuration. Storage directors may be installed to accept 8, 16, 32, or 64 logical device addresses as required by the device configuration. The addresses are installed by the customer engineer through use of switches on the 3880 interface card. Valid drive addresses are shown in Figure 13.

If a channel switch feature is installed on an eight-drive configuration, bits 3 and 4 of the address must be the same for all channel inputs. For a 16-drive configuration, bit 3 must be the same for all channel inputs.

Note: The address switches on the 3880 channel interface card, numbered 1 through 8, correspond to bit positions 0 through 7. Therefore, bits 3 and 4 correspond to switches 4 and 5.

Configuration	Valid Addresses (Hexadecimal)			
8 Drives	00-07	40-47	80-87	C0-C7
	08-0F	48-4F	88-8F	C8-CF
	10-17	50-57	90-97	D0-D7
	18-1F	58-5F	98-9F	D8-DF
	20-27	60-67	A0-A7	E0-E7
	28-2F	68-6F	A8-AF	E8-EF
	30-37	70-77	B0-B7	F0-F7
	38-3F	78-7F	B8-BF	F8-FF
	16 Drives	00-0F	40-4F	80-8F
10-1F		50-5F	90-9F	D0-DF
20-2F		60-6F	A0-AF	E0-EF
30-3F		70-7F	B0-BF	F0-FF
32 Drives	00-1F	40-5F	80-9F	C0-DF
	20-3F	60-7F	A0-BF	E0-FF
64 Drives*	00-3F	40-7F	80-BF	C0-FF
* See the 3340 and 3344 Addressing section of this manual.				

Figure 13. Valid Drive Addresses

3330, 3333, and 3350 Addressing

One to four strings can attach to each storage director in the 3880. If only one string is attached, only 8 drive addresses should be assigned to the storage director; if two strings are attached, 16 drive addresses should be assigned; if three or four strings are attached, 32 drive addresses must be assigned.

The bit assignments for 3330, 3333, and 3350 addressing are as follows.

Byte 3 of the I/O Instruction

0	2 3	4 5	7
Storage director address	3333 or 3350 A2/C2 address	Physical drive address	

3370 Addressing

One to four strings of 3370s can be attached to each storage director in the 3880. If only one string is attached, only 8 drive addresses should be assigned to the storage director; if two strings are attached, 16 drive addresses should be assigned; if three or four strings are attached, 32 drive addresses must be assigned. Each 3370 has two separate access mechanisms and two logical addresses.

The bit assignments for 3370 addressing are as follows.

Byte 3 of the I/O Instruction

0	2 3	4 5	6	7
Storage director address	Controller address	Drive address	Access mechanism	

3375 and 3380 Addressing

Information related to 3375 and 3380 addressing will be provided in a later edition of this manual.

3340 and 3344 Addressing

For configurations using 3340s only or 3340s and 3344s, the storage director must be assigned 64 drive addresses regardless of the number of drives attached. As shown below, device addressing is modified to handle the multiple logical devices on 3344 drives. Bit 2, the secondary address bit, is used to indicate a second or subsequent logical address on a physical drive.

In a configuration with only 3340s, there are no secondary addresses and bit 2 must be set to zero. Therefore, addresses in ranges '20' through '3F', '60' through '7F', 'A0' through 'BF', and 'E0' through 'FF' cannot be used in 3340-only configurations.

Byte 3 of the I/O Instruction

0	1 2	3	4 5	7
Storage director address	Secondary address bit	Controller address	Drive address	

Figure 14 shows the valid address ranges for configurations with 3340s only. Figure 15 shows the valid address ranges for configurations with both 3340s and 3344s.

3880 Storage Control

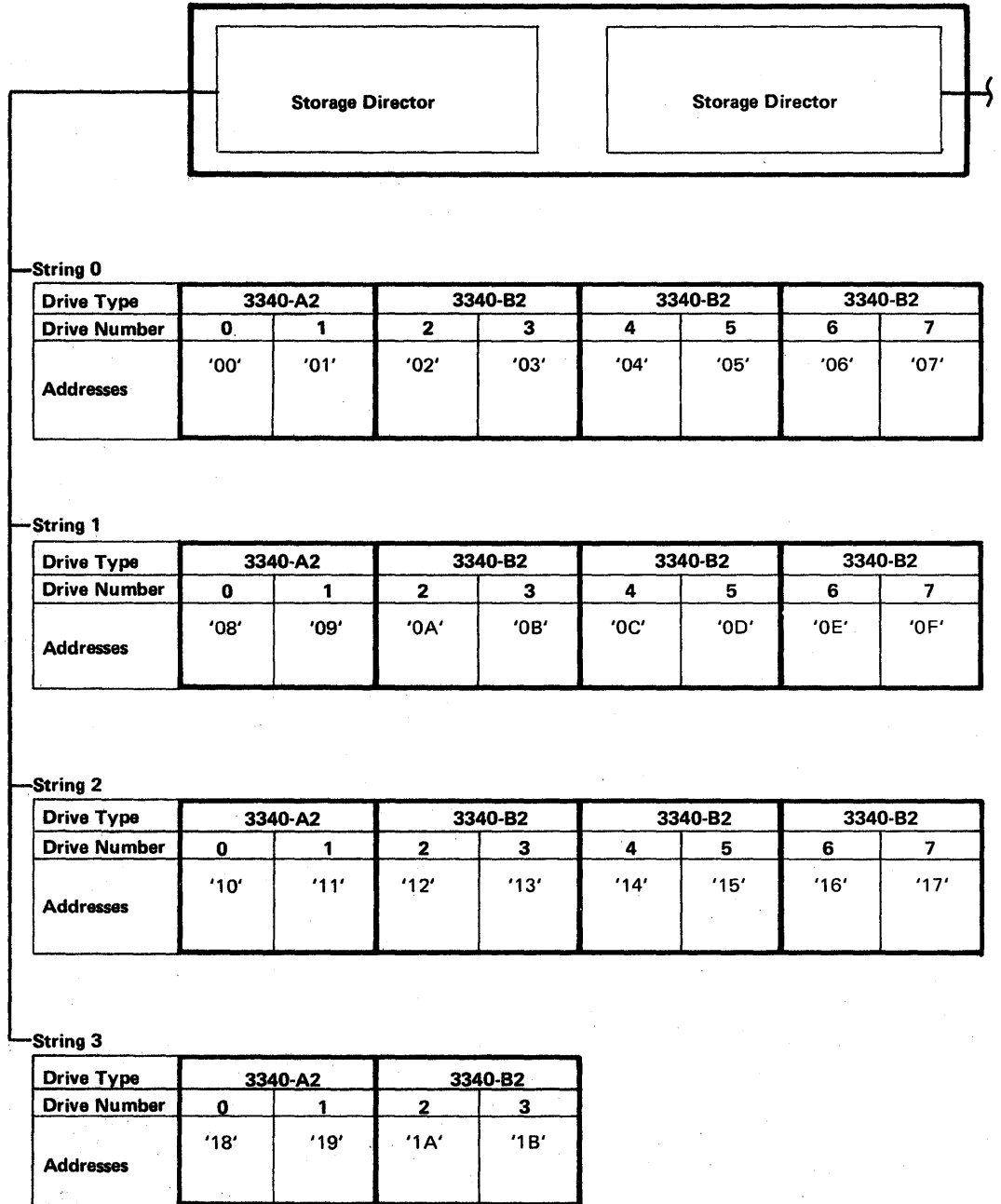

Note: Other valid address ranges for 3340-only configurations are: '40' - '5B', '80' - '9B', and 'C0' - 'DB'.

Figure 14. Valid Address Ranges for 3340-Only Configurations

3880 Storage Control

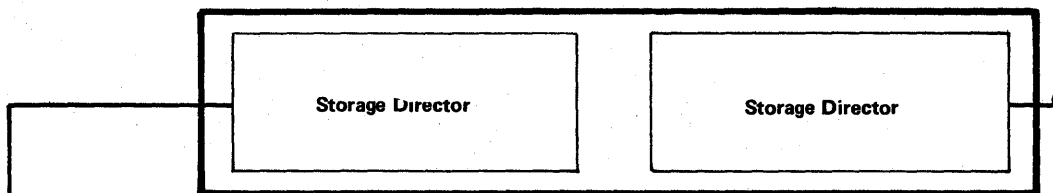

String 0

Drive Type	3340-A2		3344		3344		3344	
Drive Number	0	1	2	3	4	5	6	7
Addresses	'00'	'01'	'02'	'03'	'04'	'05'	'06'	'07'
			'22'*	'23'*	'24'*	'25'*	'26'*	'27'*
			'2A'*	'2B'*	'2C'*	'2D'*	'2E'*	'2F'*
			'32'*	'33'*	'34'*	'35'*	'36'*	'37'*

* Secondary address

String 1

Drive Type	3340-A2		3340-B2		3340-B2		3340-B2	
Drive Number	0	1	2	3	4	5	6	7
Addresses	'08'	'09'	'0A'	'0B'	'0C'	'0D'	'0E'	'0F'

String 2

Drive Type	3340-A2		3344		3344		3344	
Drive Number	2	3	0	1	4	5	6	7
Addresses	'12'	'13'	'10'	'11'	'14'	'15'	'16'	'17'
			'20'*	'21'*	'1C'*	'1D'*	'1E'*	'1F'*
			'28'*	'29'*	'38'*	'39'*	'3A'*	'3B'*
			'30'*	'31'*	'3C'*	'3D'*	'3E'*	'3F'*

* Secondary address

String 3

Drive Type	3340-A2		3340-B2	
Drive Number	0	1	2	3
Addresses	'18'	'19'	'1A'	'1B'

Note: Other valid address ranges for 3340 and 3344 configurations are '40' - '7F', '80' - 'BF', and 'C0' - 'FF'.

Figure 15. Valid Address Ranges for Mixed 3340 and 3344 Configurations

Index

A

addressing 5-2,2-10
alternate controller selected 9-4
attachment, disk storage 1-1
attention 2-5

B

BC mode 2-7
block count 3-10
block count parameters 3-10
block multiplexing feature 1-3,5-9
block size exception 7-2
bus out parity
 3330 8-1
 3340 10-1
 3350 9-1
 3370 7-1
busy 2-5

C

CAW/*see* channel address word) 2-2
CCW/*see* channel command word) 2-2
chain command (CC) flag 2-4
chain data (CD) flag 2-4
chaining requirements/*see* individual commands) 3-2
channel address word (CAW)
 description 2-2
 format 2-3
channel command word (CCW)
 description 2-2
 format 2-4
channel commands/*see also* individual commands)
 control 2-11
 Count, Key, and Data (CKD) 2-11
 count, key, and data command set
 Device Release 4-38
 Device Reserve 4-36
 Diagnostic Load 4-48
 Diagnostic Sense 4-47
 Diagnostic Sense/Read 4-50
 Diagnostic Write 4-49
 Erase 4-42
 No-Operation (No-Op) 4-2
 Read and Reset Buffered Log 4-35
 Read Count 4-24
 Read Count, Key, and Data 4-28
 Read Data 4-26
 Read Home Address 4-23
 Read Initial Program Load 4-31
 Read Key and Data 4-27
 Read Multiple, Count, Key and Data 4-29
 Read Record Zero (R0) 4-25
 Read Sector 4-32
 Recalibrate 4-3
 Restore 4-14
 Search Home Address Equal 4-16
 Search Identifier (ID) Equal 4-17
 Search Identifier (ID) Equal or High 4-19
 Search Identifier (ID) High 4-18
 Search Key Equal 4-20
 Search Key Equal or High 4-22
 Search Key High 4-21
 Seek 4-4
 Seek Cylinder 4-6

channel commands (continued)
 Seek Head 4-8
 Sense Input/Output 4-34
 Sense Input/Output Type 4-33
 Set File Mask 4-11
 Set Sector 4-13
 Space Count 4-9
 Transfer-in-Channel (TIC) 4-15
 Unconditional Reserve 4-37
 Write Data 4-45
 Write Home Address 4-39
 Write Key and Data 4-46
 Write Record Zero 4-41
 Write Special Count, Key, and Data 4-44
 Write, Count, Key, and Data 4-43
diagnostic 2-12
fixed block 2-11
fixed block command set
 Define Extent 3-4
 Device Release 3-21
 Device Reserve 3-20
 Diagnostic Control 3-23
 Diagnostic Sense/Read 3-29
 Locate 3-7
 No-Operation (No-Op) 3-3
 Read 3-11
 Read and Reset Buffered Log 3-18
 Read Device Characteristics 3-19
 Read Initial Program Load 3-13
 Sense I/O Type 3-17
 Sense Input/Output (I/O) 3-16
 Transfer-in-Channel (TIC) 3-2
 Unconditional Reserve 3-22
 Write 3-14
Format ID subcommand 3-24
 read 2-11
 Read ID subcommand 3-27,3-29
 search 2-12
 sense 2-12
 Space ID and Read Data subcommand 3-26,3-29
 subcommands for diagnostic control 3-24
 Test I/O 2-12
 Trace/Dump subcommand 3-24,3-29
 write 2-11
channel end 2-5
channel operation 2-2
channel programs
 read example, CKD 4-56
 read example, fixed block 3-33
 track formatting example, CKD 4-51
 update write example, CKD 4-54
 write example, fixed block 3-31
channel selection 5-8
channel status 2-6
channel status word (CSW)
 description 2-2
 format 2-5
channel switching 5-8
check data error, 3370 7-3
check indicator 10-24
clear I/O 2-1
command address 2-5
command code, general description 2-4
command codes (CKD) 4-1
command codes (fixed block) 3-1
command reject
 3330 8-1
 3340 10-1

- command reject (continued)
 - 3350 9-1
 - 3370 7-1
- command retry
 - 3330 6-8
 - 3350 6-8
 - 3370 6-7
- command retry feature 1-4,5-8
- commands/*see* channel commands) 2-11
- configuration/*see* disk storage attachment) 1-1
- console error message 6-1
- contingent connection 2-10
- control unit end 2-5
- correctable (sense bit)
 - 3330 8-4
 - 3350 9-4
 - 3370 7-3
- count field, CCW 2-4
- count field, CSW 2-6
- count, key, and data command set 4-1
- CSW/*see* channel status word) 2-2

D

- data address 2-4
- data check
 - 3330 8-1
 - 3340 10-1
 - 3350 9-1
 - 3370 7-1
- data flow 1-2
- deferred condition code 2-5
- define extent command 3-4
- define extent mask 3-26
- device addressing 2-10
- device attachment 1-1,1-4,1-5
- device end 2-5
- device features 1-4,1-5
- Device Release command (CKD) 4-38
- Device Release command (fixed block) 3-21
- Device Reserve command (CKD) 4-36
- Device Reserve command (fixed block) 3-20
- Diagnostic Control command (fixed block) 3-23
- Diagnostic Load command 4-48
- Diagnostic Sense command 4-47
- Diagnostic Sense/Read command (CKD) 4-50
- Diagnostic Sense/Read command (fixed block) 3-29
- Diagnostic Write command 4-49
- disk storage attachments
 - 3330, 3333, and 3350 attachment 1-4
 - 3340 and 3344 attachment 1-5
 - 3370 attachment 1-5
- Displace ID subcommand 3-28

E

- EC mode 2-7
- eight-channel switch 5-8
- Enable/Disable switches 10-24
- end of cylinder, 3330 8-3
- end-of-file example 5-4
- end-of-file feature 1-4,5-4
- environmental data present
 - 3330 8-4
 - 3340 10-4
 - 3350 9-4
 - 3370 7-3
- equipment check
 - 3330 8-1
 - 3340 10-1

equipment check (continued)

- 3350 9-1
- 3370 7-1
- Erase command 4-42
- error condition table
 - 3330 9-17
 - 3340 10-18
 - 3344 10-18
 - 3350 9-17
 - 3370 7-15
- error correction function
 - count, key, and data devices 6-3
 - example, CKD 6-5
 - example, fixed block 6-2
 - fixed block devices 6-1
- error detection 5-9
- error logging 5-9
- error recording 5-9
- error recovery procedures
 - console error message 6-1
 - count, key, and data devices 6-3
 - error correction 6-1
 - fixed block devices 6-1
 - restart CCW 1, CKD 6-6
 - restart CCW 1, fixed block 6-2
 - restart CCW 2, CKD 6-6
 - restart CCW 2, fixed block 6-3
 - restart CCWs 6-2

F

- features
 - block multiplexing 5-9
 - command retry 5-8
 - eight-channel switch 5-8
 - end of file 5-4
 - error detection 5-9
 - error logging 5-9
 - general description 1-3
 - list of 1-3
 - multitrack 5-1
 - record overflow feature 5-2
 - remote switch 5-9
 - rotational position sensing 5-5
 - standard and special 5-1
 - two-channel switch pair 5-8
 - two-channel switch pair, additional 5-8
 - usage/error recording 5-9
- 3330/3333 1-4
- 3340 1-5
- 3344 1-5
- 3350 1-5
- 3370 1-5
- file mask 4-12
- file protected
 - 3330 8-3
 - 3340 10-3
 - 3350 9-3
 - 3370 7-2
- fixed block command set 3-1
- format defective block 3-8
- Format ID subcommand 3-24,3-29

H

- Halt device 2-1
- Halt I/O 2-1
- home address area 3330 4-39
- home address area 3340 4-40
- home address area 3350 4-39

I

- I/O addressing 2-10,A1
- I/O instructions
 - format 2-3
 - general description 2-1
- indicators 10-24
- indirect data address 2-4
- initial status 2-8
- input/output operations
 - channel operation 2-2
 - general description 2-1
- internal retry 6-7
- intervention required
 - 3330 8-1
 - 3340 10-1
 - 3350 9-1
 - 3370 7-1
- invalid track format
 - 3330 8-3
 - 3340 10-3
 - 3350 9-3

L

- Locate command 3-7
- logout pending 2-5

M

- mask byte 3-5
- mask byte (CKD) 4-12
- multiple track (*see* multitrack feature) 1-4,5-1
- multitrack feature 1-4,5-1

N

- No-Operation command (CKD) 4-2
- No-Operation command (fixed block) 3-3
- no record found
 - 3330 8-3
 - 3340 10-3
 - 3350 9-3

O

- offset parameters 3-6
- On/Off switch 10-24
- operation byte 3-7
- operation incomplete
 - 3330 8-3
 - 3340 10-3
 - 3350 9-3
 - 3370 7-2
- operator message
 - 3330 8-3
 - 3340 10-3
 - 3350 9-3
 - 3370 7-2
- operator panel 10-24
- overflow records
 - (*see also* record overflow feature) 5-2
- overrun
 - 3330 8-1
 - 3340 10-1
 - 3350 9-2
 - 3370 7-1

P

- parameters, diagnostic control 3-24
- pending status 2-9
- permanent error
 - 3330 8-3
 - 3340 10-3
 - 3350 9-3
 - 3370 7-2
- Power Enable 10-24
- Power Off 10-24
- Power On 10-24
- Power Seq Complete 10-24
- Process indicator 10-24
- program controlled interrupt 2-4
- program status word (PSW)
 - description 2-6
 - format 2-7
- PSW (*see* program status word) 2-6

R

- Read and Reset Buffered Log command (CKD) 4-35
- Read and Reset Buffered Log command (fixed block) 3-18
- Read command (fixed block) 3-11
- Read Count command 4-24
- Read Count, Key, and Data command 4-28
- Read Data command 4-26
- read data operation code 3-10
- Read Device Characteristics command (fixed block) 3-19
- read example, CKD 4-56
- read example, fixed block 3-33
- Read Home Address command 4-23
- Read ID subcommand 3-27,3-29
- Read Initial Program Load command (CKD) 4-31
- Read IPL command (fixed block) 3-13
- Read Key and Data command 4-27
- Read Multiple Count, Key and Data command 4-29
- Read Record Zero command 4-25
- Read Replicated Data 3-9
- Read R0 command 4-25
- Read Sector command 4-32
- Recalibrate command 4-3
- record overflow feature
 - description 1-4
 - example 5-2
 - formatting overflow records 5-2
 - processing overflow records 5-3
- recovery action table
 - 3330/3350 9-18
 - 3340 and 3344 10-19
 - 3370 7-16
- remote switch features 1-3,5-9
- replication count 3-10
- restart CCWs
 - restart CCW 1, CKD 6-6
 - restart CCW 1, fixed block 6-2
 - restart CCW 2, CKD 6-6
 - restart CCW 2, fixed block 6-3
- Restore command 4-14
- retry, command (*see* command retry) 6-7
- retry, internal 6-7
- rotational position sensing (RPS) feature 5-5
- rotational position sensing, example 5-6,5-8
- RPS (*see* rotational position sensing) 5-6
- RPS present 10-4

S

- Search Home Address Equal command 4-16
- Search Identifier (ID) Equal command 4-17
- Search Identifier (ID) Equal or High command 4-19
- Search Identifier (ID) High command 4-18
- Search Key Equal command 4-20
- Search Key Equal or High command 4-22
- Search Key High command 4-21
- sector location, calculating 5-5
- seek address 4-4,4-6,4-8
- seek check 10-2
- Seek command 4-4
- Seek Cylinder command 4-6
- Seek Head command 4-8
- sense bytes - 3370
 - byte 0 7-1
 - byte 1 7-3
 - byte 2 7-3
 - byte 3 7-3
 - byte 4 7-3
 - byte 5 7-3
 - byte 6 7-3
 - byte 7 7-4
 - format 0
 - bytes 8-23 7-4
 - message table 7-4
 - format 1
 - bytes 8-13 7-5
 - bytes 14-17 7-6
 - bytes 18-23 7-7
 - bytes 22 and 23 7-8
 - message table 7-8
 - format 2
 - bytes 8-23 7-9
 - message table 7-9
 - format 3 (hardware detected)
 - bytes 8-23 7-10
 - message table 7-10
 - format 3 (microcode detected)
 - bytes 8-23 7-11
 - message table 7-11
 - format 4
 - bytes 8-23 7-12
 - message table 7-12
 - format 5
 - bytes 8-23 7-13
 - message table 7-13
 - format 6
 - bytes 8-23 7-14
 - message table 7-14
- sense bytes - 3330
 - byte 0 8-1
 - byte 1 8-3
 - byte 2 8-4
 - byte 3 8-4
 - byte 4 8-4
 - byte 5 8-4
 - byte 6 8-5
 - byte 7 8-5
 - format 0
 - bytes 8-23 8-6
 - message table 8-6
 - format 1
 - bytes 13-17 8-7
 - bytes 14-23 8-8
 - message table 8-9
 - format 2
 - bytes 8-23 8-10
 - message table 8-10
 - format 3 (hardware detected)
 - bytes 8-23 8-11
 - message table 8-11
- sense bytes - 3330 (continued)
 - format 3 (microcode detected)
 - bytes 8-23 8-12
 - message table 8-12
 - format 4
 - bytes 8-23 8-13
 - message table 8-13
 - format 5
 - bytes 8-23 8-14
 - message table 8-14
 - format 6
 - bytes 8-23 8-15
 - message table 8-15
- sense bytes - 3340 and 3344
 - byte 0 10-1
 - byte 1 10-3
 - byte 2 10-4
 - byte 3 10-4
 - byte 4 10-4
 - byte 5 10-5
 - byte 6 10-5
 - byte 7 10-6
 - format 0
 - bytes 8-23 10-7
 - message table 10-7
 - format 1
 - bytes 8-12 10-8
 - bytes 13-17 10-9
 - bytes 18-20 10-10
 - bytes 21-23 10-11
 - message table 10-11
 - format 2
 - bytes 8-23 10-12
 - message table 10-12
 - format 3 (hardware detected)
 - bytes 8-23 10-13
 - message table 10-13
 - format 3 (microcode detected)
 - bytes 8-23 10-14
 - message table 10-14
 - format 4
 - bytes 8-23 10-15
 - message table 10-15
 - format 5
 - bytes 8-23 10-16
 - message table 10-16
 - format 6
 - bytes 8-23 10-17
 - message table 10-17
- sense bytes - 3350
 - byte 0 9-1
 - byte 1 9-3
 - byte 2 9-4
 - byte 3 9-4
 - byte 4 9-4
 - byte 5 9-4
 - byte 6 9-5
 - byte 7 9-5
 - format 0
 - bytes 8-23 9-6
 - message table 9-6
 - format 1
 - bytes 8-11 9-7
 - bytes 12-17 9-8
 - bytes 18 and 20 9-9
 - bytes 21-23 9-10
 - message table 9-10
 - format 2
 - bytes 8-23 9-11
 - message table 9-11

- sense bytes - 3350 (continued)
 - format 3 (hardware detected)
 - bytes 8-23 9-12
 - message table 9-12
 - format 3 (microcode detected)
 - bytes 8-23 9-13
 - message table 9-13
 - format 4
 - bytes 8-23 9-14
 - message table 9-14
 - format 5
 - bytes 8-23 9-15
 - message table 9-15
 - format 6
 - bytes 8-23 9-16
 - message table 9-16
- Sense I/O command (CKD) 4-34
- Sense I/O command (fixed block) 3-16
- Sense I/O Type command (CKD) 4-33
- Sense I/O Type command (fixed block) 3-17
- Set File Mask command 4-11
- Set Sector command 4-13
- skip flag 2-4
- SLI** (*see suppress length indicator*) 2-4
- Space Count command 4-9
- space count example 4-10
- Space ID and Read Data subcommand 3-26,3-29
- Start I/O 2-1
- Start I/O Fast Release 2-1
- status modifier 2-5
- status pending indicator 10-24
- status presentation
 - (*see also individual commands*)
 - immediate commands 2-8
 - initial status 2-8
 - pending status 2-9
 - priority of pending status 2-10
 - suppressible status 2-10
- storage directors 1-1
- subchannel key 2-5
- subcommands for diagnostic control 3-24
- subsystem power 10-24
- suppress length indicator (SLI) 2-4
- suppressible status 2-10
- switches 10-24
- system attachment 1-1
- system configuration 10-24

T

- Test I/O 2-1,2-12
- TIC command (CKD) 4-15
- TIC command (fixed block) 3-2
- Trace/Dump subcommand 3-24,3-29
- track condition check 10-2
- track descriptor record 4-41
- track formatting example, CKD 4-51
- Transfer-in-Channel command (CKD) 4-15
- Transfer-in-Channel command (fixed block) 3-2
- two-channel switch pair feature 1-3,5-8
- two-channel switch pair, additional feature 1-3,5-8

U

- unconditional reserve command (CKD) 4-37
- unconditional reserve command (fixed block) 3-22
- unit check 2-5
- unit emergency 10-24
- unit exception 2-6
- update write example, CKD 4-54
- usage/error recording 5-9

W

- wait indicator 10-24
- write and check data 3-9
- Write CKD command 4-43
- Write command (fixed block) 3-14
- Write Count, Key, and Data command 4-43
- Write Data command 4-45
- write data operation code 3-9
- write example (fixed block) 3-31
- Write Home Address command 4-39
 - write inhibited
 - 3330 8-3
 - 3340 10-3
 - 3350 9-3
 - 3370 7-2
- Write Key and Data command 4-46
- Write Record Zero (R0) command 4-41
- Write Special CKD command 4-44

IBM 3880 Storage Control Description

READER'S
COMMENT
FORM

Order No. GA26-1661-3

This manual is part of a library that serves as a reference source for systems analysts, programmers, and operators of IBM systems.

This form may be used to communicate your views about this publication. They will be sent to the author's department for whatever review and action, if any, is deemed appropriate. Comments may be written in your own language; use of English is not required.

IBM may use or distribute any of the information you supply in any way it believes appropriate without incurring any obligation whatever. You may, of course, continue to use the information you supply.

Note: Copies of IBM publications are not stocked at the location to which this form is addressed. Please direct any requests for copies of publications, or for assistance in using your IBM system, to your IBM representative or to the IBM branch office serving your locality.

Possible topics for comment are:

Clarity Accuracy Completeness Organization Coding Retrieval Legibility

Check if you wish a reply.

If you wish a reply, give your name and mailing address:

What is your occupation ? _____

Number of latest Newsletter associated with this publication: _____

Thank you for your cooperation. No postage stamp necessary if mailed in the U.S.A. (Elsewhere, an IBM office or representative will be happy to forward your comments.)

Please use pressure sensitive or other gummed tape to seal this form.
-----Cut or Fold Along Line-----

Reader's Comment Form

Cut or Fold Along Line

IBM 3880 Storage Control Description (File No. 4300-07, S/370-07) Printed in U.S.A. GA26-1661-3

Fold and Tape

Please Do Not Staple

Fold and Tape



NO POSTAGE
NECESSARY
IF MAILED
IN THE
UNITED STATES

BUSINESS REPLY MAIL
FIRST CLASS PERMIT NO. 40 ARMONK, N.Y.

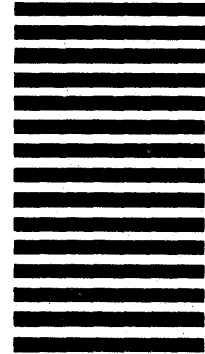

POSTAGE WILL BE PAID BY ADDRESSEE:

International Business Machines Corporation
Department G26
555 Bailey Avenue
San Jose, California 95150

Fold and Tape

Please Do Not Staple

Fold and Tape



International Business Machines Corporation
Data Processing Division
1133 Westchester Avenue, White Plains, N.Y. 10604

IBM World Trade Americas/Far East Corporation
Town of Mount Pleasant, Route 9, North Tarrytown, N.Y., U.S.A. 10591

IBM World Trade Europe/Middle East/Africa Corporation
360 Hamilton Avenue, White Plains, N.Y., U.S.A. 10601



International Business Machines Corporation
Data Processing Division
1133 Westchester Avenue, White Plains, N.Y. 10604

IBM World Trade Americas/Far East Corporation
Town of Mount Pleasant, Route 9, North Tarrytown, N.Y., U.S.A. 10591

IBM World Trade Europe/Middle East/Africa Corporation
360 Hamilton Avenue, White Plains, N.Y., U.S.A. 10601