

ABOUT THIS MANUAL

This is the Optimem 1000 Optical Disk Drive OEM Manual, revision 4, dated April 1985.

While every effort has been made to ensure that the information provided is correct, please notify us in the event of an error or inconsistency. Direct your comments to:

Optimem
Marketing Group
435 Oakmead Parkway
Sunnyvale, CA 94086
(408) 737-7373

Optimem makes no representation or warranties with respect to the contents hereof and specifically disclaims any implied warranties or merchantability of fitness for any purpose.

Further, Optimem reserves the right to revise this publication and to make changes from time to time in the contents without obligation to notify any person of such revisions or changes.

The information contained herein is copyrighted. No portion of this document can be duplicated or sold without the express written consent of Optimem Marketing. Failure to comply with this notice could entail legal action to remedy such violation.

WARNING: This equipment generates and uses radio frequency energy and if not installed and used properly, i.e., in strict accordance with the instructions manual, may cause harmful interference to radio communications. It has been tested and found to comply with the limits for a Class A computing device pursuant to Subpart J of Part 15 of FCC Rules which are designed to provide reasonable protection against such interference when operated in a commercial environment.

Operation of this equipment in a residential area is likely to cause interference in which case the user at his own expense will be required to take whatever measures may be required to correct the interference.

T A B L E O F C O N T E N T S

1. GENERAL INFORMATION.....	1
1.1. Product Description.....	2
1.1.1. Overview.....	2
1.1.2. Key Features.....	3
1.1.3. Medium.....	3
1.1.4. Comparison to Magnetic Disk Drives.....	3
1.1.5. Power Supply.....	4
1.1.6. SCSI.....	4
1.1.7. Configuration Options.....	4
1.1.8. Rack Slides.....	5
1.2. Optimem 1000 Specification Summary.....	6
1.3. Functional Description.....	10
1.3.1. Mechanical Package.....	10
1.3.2. Optics Module.....	10
1.3.3. Read Operations.....	10
1.3.4. Write Operations.....	11
1.3.5. Positioning Servos.....	11
1.3.6. Drive Control.....	12
1.4. Drive Interfaces.....	12
2. INSTALLATION.....	13
2.1. Unpacking the Drive.....	13
2.2. AC Power Connection.....	14
2.3. On/Off Switch and Fuse.....	14
2.4. Mounting the Drive.....	14
2.4.1. Mounting Holes for Slides.....	14
2.4.2. Stand Alone Enclosure.....	14
2.4.3. Air Flow Requirements.....	14
2.5. Connecting the Drive.....	15
2.5.1. Description.....	16
2.5.2. Transmitter Characteristics.....	16
2.5.3. Receiver Characteristics.....	16
2.5.4. Cable Requirements.....	16
2.5.5. Termination.....	16
2.6. Connectors.....	18
2.7. Interleave Selection.....	18
2.8. Repacking the Drive.....	18
3. DRIVE OPERATIONS.....	19
3.1. Front Panel.....	19
3.2. Characteristics of the Cartridge.....	20
3.2.1. Cartridge Components.....	20
3.2.2. Write Protect.....	22
3.2.3. Empty Cartridge.....	22
3.2.4. Side 1 - Side 2.....	22
3.3. Loading the Cartridge.....	22
3.4. Unloading the Cartridge.....	26
3.5. Spin Up/Spin Down.....	28

3.6. Cartridge Cautions.....	29
3.6.1. Impact.....	29
3.6.2. Temperature.....	30
3.6.3. Humidity.....	30
3.6.4. Storage.....	31
3.7. Damaged Cartridges.....	32
4. SCSI CONTROLLER.....	33
4.1. OVERVIEW OF SCSI.....	33
4.2. Reference Documents.....	33
4.2.1. ANSC Specification.....	33
4.2.2. The Optimem 1000 Interface Document.....	33
4.3. Theory of SCSI.....	33
4.4. Controller Capacity Specifications.....	34
4.5. Data Transfer Rates.....	35
4.6. Medium Defects.....	35
4.7. Data Error Rates.....	35
4.7.1. Recoverable Errors.....	36
4.7.2. Nonrecoverable Errors.....	36
4.7.3. Nondetected Errors.....	36
4.8. SCSI Bus.....	37
4.9. SCSI Bus Phases.....	39
4.9.1. BUS FREE Phase.....	39
4.9.2. ARBITRATION Phase.....	39
4.9.3. SELECTION Phase.....	39
4.9.4. RESELECTION Phase.....	39
4.9.5. COMMAND Phase.....	39
4.9.6. DATA Phase.....	39
4.9.7. STATUS Phase.....	40
4.9.8. MESSAGE Phase.....	40
4.9.9. Phase Sequencing.....	40
4.10. Commands.....	41
4.10.1. Command Descriptor Block.....	41
4.10.2. Operation Code.....	42
4.10.3. Logical Unit Number.....	44
4.10.4. Logical Block Address.....	44
4.10.5. Transfer Length.....	44
4.10.6. Control Byte.....	44
4.10.7. Reserved Bits and Bytes.....	44
4.10.8. Completion Status Byte.....	45
4.10.9. Completion Status Descriptions.....	45
5. OPTIMEM DRIVE INTERFACE (ODI).....	46
5.1. Description.....	46
5.2. Definition of the ODI.....	46
5.3. ODI Bus Signals.....	46
5.4. ODI Cable Pin Assignments.....	47
5.5. Modes of Operation.....	48
5.6. Theory of Operation.....	49
5.6.1. Sending Commands.....	49
5.6.2. Receiving Status.....	49
5.6.3. Busy/Ready.....	49
5.6.4. Spiral Track.....	49

- 5.7. Functional Operation.....50
 - 5.7.1. Drive Selection Response.....50
 - 5.7.2. Seek.....50
 - 5.7.3. Write.....50
 - 5.7.4. Read.....50
- 6. DISK AND FORMAT.....51
 - 6.1. General Description.....51
 - 6.2. Plastic Substrate51
 - 6.3. Disk and Substrate Specification Summary.....52
 - 6.4. Cartridge.....52
 - 6.4.1. General Description.....52
 - 6.4.2. Cartridge Specification Summary.....53
- 7. MAINTENANCE.....55
 - 7.1. Warning.....55
 - 7.2. Diagnostics.....55
 - 7.3. PC Board Replacement.....55
 - 7.3.1. PC Board Access.....57
 - 7.3.2. Board Location and Description57
 - 7.3.3. PC Board Part Numbers58
 - 7.4. Power Supply.....59
 - 7.4.1. Features.....59
 - 7.4.2. Installation.....59
 - 7.4.3. Power Supply Removal.....61
 - 7.5. Preventative Maintenance Philosophy.....62

Appendices

- A. Power Supply Reconfiguration 115V to 230V.....63
- B. SCSI Controller Reconfiguration.....64
 - B.1. SCSI ID.....64
 - B.2. Termination.....65
 - B.3. Interleave Selection.....65
- C. LUN Reconfiguration.....66
 - C.1. LUN Selection.....66
 - C.2. Termination.....66

L I S T O F F I G U R E S

1-1: The Optimem 1000 Optical Disk Drive.....	2
1-2: Dimensions of the Optical Disk Drive.....	6
2-1: Unpacking the Drive.....	13
2-2: Rear View of the Drive.....	15
2-3: Mounting Holes.....	15
2-4: Host Adapter to Optical Disk Controller Line Termination.....	17
3-1: Front Panel Configuration.....	19
3-2: Optical Disk Cartridge Components.....	20
3-3: Optical Disk Cartridge: Dimensions and Write Protect.....	21
3-4: Loading the Cartridge.....	22
3-5: Unloading the Cartridge.....	26
3-6: Protecting the Cartridge.....	29
3-7: Temperature Range and Limits for Cartridge Operation.....	30
3-8: Removing the Cartridge When Not in Use.....	31
4-1: SCSI System Configuration.....	34
4-2: Optimem 1000 Phase Sequencing.....	41
4-3: Typical Command Descriptor Block for Six-Byte Commands.....	41
4-4: Typical Command Descriptor Block for Ten-Byte Commands.....	42
6-1: Cartridge Dimensions.....	54
7-1: Exploded View of Drive Components.....	56
7-2: PC Board Locations.....	57
7-3: Power Supply Attachment.....	60
7-4: Power Supply Internal Fuse.....	61
B-1: SCSI ID Bit.....	64
B-2: SCSI ID JUMPERS.....	65
C-1: LUN Assignment.....	66

L I S T O F T A B L E S

4-1: Capacity Specification in the EDAC Mode.....	35
4-2: SCSI Cable Pin Assignments.....	37
4-3: Summary of Commands Implemented.....	43
5-1: ODI Cable Pin Assignments.....	47
5-2: Summary of ODI Modes.....	48
6-1: Disk Specification Summary.....	52
6-2: Substrate Specification Summary.....	52
6-3: Cartridge Specification Summary	53
7-1: Power Connector Pin-outs.....	62

SECTION I**INTRODUCTION****1. GENERAL INFORMATION**

Products containing lasers are regulated by the Radiation Control for Health and Safety Act of 1968. These products must comply with safety regulations as defined by 21 CFR subchapter J of the Federal Register as outlined in Health and Human Services publication 80-8035. The U.S. Department of Health and Human Services has formed the National Center for Devices and Radiological Health which is responsible for maintaining these laws (formerly known as the U.S. Bureau of Radiological Health, the department is now commonly referred to as the BRH).

The Optimem 1000 has been designed to comply with these regulations and the necessary report has been filed. In order to maintain compliance, annual reports must be filed with the Department of Health. If the Optimem 1000 is resold under another name or model number, a report must be mailed to the following address so that this information can be included in the annual report in compliance with the law:

Compliance Office
Optimem
435 Oakmead Parkway
Sunnyvale, CA 94086

In addition, any reports of accidents caused by laser radiation from an Optimem 1000 should be reported to the same address so that they can be investigated.

In compliance with 21 CFR subchapter J, portions of this drive may be serviced only by authorized service technicians. These restricted portions are indicated by the warning below. Refer to Figure 1-2.

DANGER

INVISIBLE LASER RADIATION WHEN OPEN.
AVOID DIRECT EXPOSURE TO BEAM.

THIS PRODUCT CONFORMS TO THE APPLICABLE
REQUIREMENTS OF 21 CFR SUBCHAPTER J AT
DATE OF MANUFACTURE.

1.1. Product Description

1.1.1. Overview

The Optimem 1000 is the first in a family of optical drives using nonerasable laser technology to read and write digital data. With a storage capacity of 1000 megabytes (one gigabyte) on one side of a removable 12-inch disk, the Optimem product is an ideal low-cost, mass storage device for such office applications as records management, electronic file cabinets and general archival storage, as well as for medical image processing applications like digital radiography. In addition, since the Optimem drive uses nonerasable technology and a removable disk, it is well suited as a backup device for Winchester drives or in financial applications like audit trails. A front view of the drive is shown in Figure 1-1.

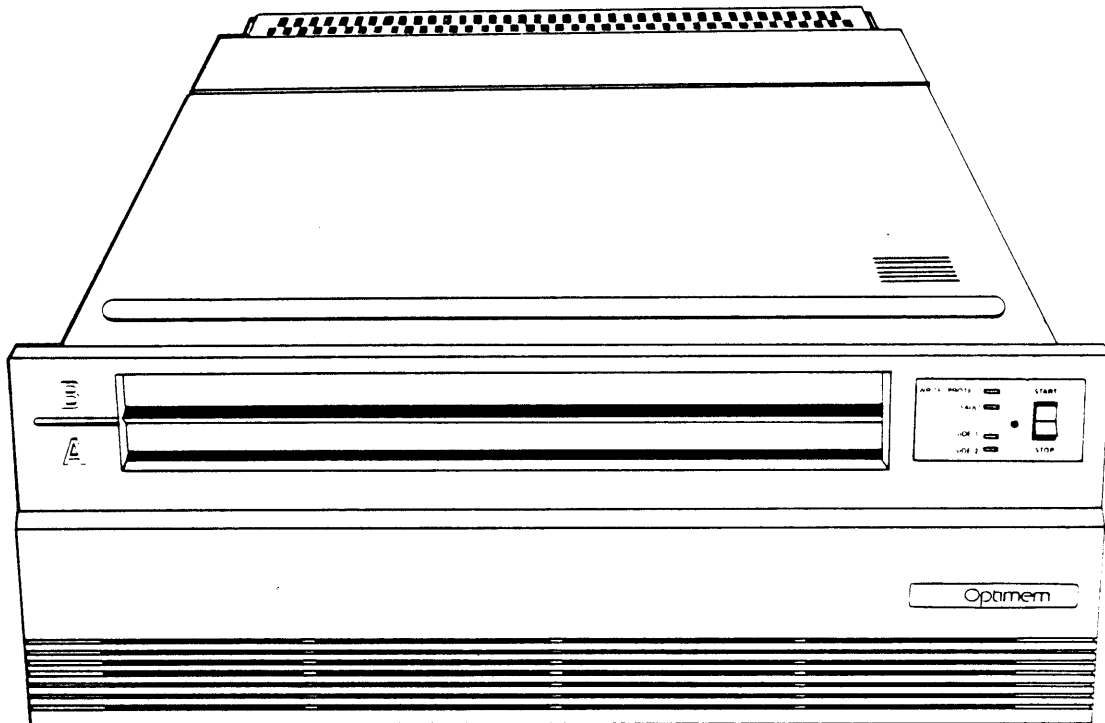

Fig. 1-1: The Optimem 1000 Optical Disk Drive

1.1.2. Key Features

1. Microprocessor-controlled electronics for design flexibility.
2. One gigabyte of removable medium for low cost off-line storage of data.
3. Built-in diagnostics facilitate maintenance by simplifying fault isolation.
4. Compact size, providing mass storage in minimal floor space.
5. Low power consumption, simplifying installation in office environments.
6. Potential to read both factory-mastered and drive-written data.

1.1.3. Medium

Information is recorded and played back on a removable 12-inch disk, which is protected during operator handling, transport and storage by a hard shell cover. This cartridge also accommodates labeling information and incorporates write protect and operator interlock features. The Optimem medium is pregrooved for servo-tracking and preformatted with sector address information.

1.1.4. Comparison to Magnetic Disk Drives

There are a number of differences between the Optimem 1000 and most conventional magnetic disk drives. The major difference is that the recording medium is write-once. This requires that updates to a file be handled differently than on a re-writeable medium. In addition, the controller buffers a full sector of data before it begins writing in order to allow asynchronous operation at the host interface.

The high track density of the Optimem 1000 also causes some operational differences. The maximum runout on the disk is the equivalent of 40 tracks. Seek time is not fixed because the amount of runout varies. This runout depends on the following factors: the master disk, disk manufacturing tolerances, spindle clamping tolerances, spindle runout and disk centering tolerances.

The Optimem 1000 uses a Rotary Actuator for coarse positioning and a Two-Axis Actuator for fine positioning. The Two-Axis Actuator has a low mass to follow the track runout. This allows it to rapidly seek within a band of tracks which spans approximately plus or minus 20 tracks (the equivalent of one megabyte) from the center position of the read/write beam. If the seek length exceeds 140 tracks, the drive uses the rotary actuator, which results in a longer seek time. Therefore, the organization of data on the disk can make a significant difference in the performance of the Optimem 1000. Fortunately, the seeks are closely grouped in most applications. This makes the seek performance of the disk drive much better than average access time would indicate.

Information is also recorded differently on the Optimem 1000 than on conventional magnetic disk drives. It is recorded in a continuous spiral

format, allowing the capability to continuously read or write data on the disk. The only disadvantage is the possible addition of one latency in reverting to the beginning of the track.

1.1.5. Power Supply

The Optimem 1000 is provided with a switching power supply for wide input voltage tolerance and immunity from input frequency variations. The unit will operate at either 50 or 60 hertz. The highly efficient switching design also minimizes the heat load contributed by the power supply, resulting in reduced cooling requirements.

Additional features provided by the power supply module include:

1. AC input filters for suppression of conducted noise.
2. Remote shutdown capability in case the temperature rises above tolerance level.
3. Overvoltage, overload, short-circuit and power failure protection.

1.1.6. SCSI

System integration of the Optimem 1000 is simplified through the industry standard SCSI (Small Computer System Interface). The Optimem 1000 Controller designed for the SCSI, occupies one slot in the card cage. Working in conjunction with the Controller is the EDAC Functions (error detection and correction) Board which also occupies one slot. The controller will accommodate up to seven slave drives (drives without the SCSI Controller and EDAC) in a daisy-chain configuration. The EDAC corrects errors off the disk from an uncorrected level of 1 error in 10^4 to 1 error in 10^{12} . In addition, the error detection capability of the code implemented in the EDAC electronics detects uncorrected or miscorrected errors to a level in excess of 1 error in 10^{16} , providing further assurance of data integrity.

Additional features in the SCSI include:

1. The controller automatically writes block addresses with the data and the EDAC corrects them upon readback, ensuring that the correct block is read.
2. Two 16-bit CRC polynomials written with the data are corrected by the EDAC. Subsequent comparison against the data provides redundant error checking.

1.1.7. Configuration Options

The Optimem 1000 is designed for a wide variety of applications and can be ordered with several configuration options to meet the needs of the OEM customer.

A system can be configured with the Optimem 1000 alone or used in conjunction with other peripheral devices connected to the SCSI. The Optimem 1000 can

also be configured in a master/slave design with the master drive containing the controller and attaching up to seven additional slave drives. A slave drive is defined as a drive with no controller or EDAC.

The Optimem 1000 occupies seven inches of panel space in a standard 19-inch rack and is 24 inches deep. Including controller, it requires less than 230 watts to operate, thereby greatly reducing power and cooling requirements. Microprocessor-controlled electronics and modular design simplify field maintenance and repair.

1.1.8. Rack Slides

Rack slides are optionally provided with the drive to simplify mounting and servicing in rack-mounted installations. The slides are predrilled to match the mounting holes in the drive basepan. The latching mechanism on the slide is designed to interface with a latch release built into the front panel of the drive.

1.2. Optimem 1000 Specification Summary

Physical Size and Dimensions

The dimensions of the optical disk drive are shown in Figure 1-2.

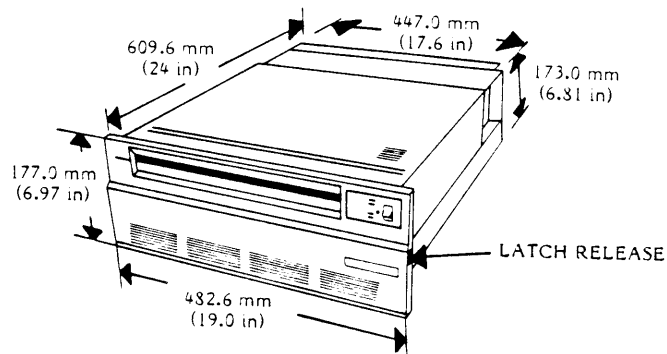

Fig. 1-2: Dimensions of the Optical Disk Drive

Performance Specifications

Capacity (Formatted)

Per Sector	1024 Bytes
Sectors per track	25 sectors
Capacity per track	25 Kbytes
Tracks per surface	40,000 tracks
Capacity	1000 Mbytes
Transfer Rate	5 Mbits/sec
Basic Drive	0.48 Mbytes/sec
SCSI	1.0 Mbyte/sec burst
Latency (average)	27 msec

Access Time (including settling)
Typical positioning time

Full stroke seek	230 msec
Average	145 msec
Single track	2 msec
+/-20 track seek	24 msec
Average +/-20 track seek	8 msec
Maximum positioning time	
Full stroke seek	250 msec
Single track	3 msec
Average	150 msec

Functional Specifications

Rotational Speed	1122 rpm
Recording density (inside track)	15,300 bpi (1.68 micrometers per bit)
Track density	14,500 tpi (1.75 micrometers per track)
Media	Optimem 1001 (singlesided) Optimem 1001 (doublesided)

Physical Specifications

Operating

Temperature	10°C to 43°C (50°F to 109°F), 10°C (18°F) per hour max. gradient
Humidity	10 to 90% RH, 10% per hour max. gradient
Maximum wet bulb	26.7°C (80°F)

Transit

Temperature -40°C to 60°C (-40°F to 140°F), 15°C (27°F) per hour max. gradient

Humidity 10 to 90% RH, 10% per hour max. gradient

Storage

Temperature -40°C to 60°C (-40°F to 140°F), 15°C (27°F) per hour max. gradient

Humidity 10 to 90% RH, 10% per hour max. gradient

Altitude

Operating 0 to 1900 meters

Storage -300 to 3700 meters

DC voltage requirements (not applicable with power supply option)

+15 Vdc +/-10% at 4 A peak, 50 mv p-p ripple

-15 Vdc +/-10% at 4 A peak, 50, mv p-p ripple

+5 Vdc +/-5% A peak, 100 mv p-p ripple

AC voltage requirements (with power supply option)

90 to 132 Vac at 1.8 A RMS

180 to 260 Vac at 0.9 A RMS

Mechanical dimensions (exclusive of faceplate)

Height: 173mm (6.81 inches)

Width: 447mm(17.6 inches)

Depth: 609.6mm (24 inches)

Faceplate dimensions

Height: 177mm (6.97 inches)

Width: 483mm (19.0 inches)

Reliability Specifications

MTBF	5000 POH under typical usage
PM	Not required
MTTR	30 minutes
Design life	5 years
Error rates:	
Nonrecoverable	1 per 10^{12} bits read
Nondetected	1 per 10^{16} bits read

1.3. Functional Description

1.3.1. Mechanical Package

The mechanical modular design of the Optimem 1000 facilitates its manufacture and service. The separation of functions between modules simplifies diagnostics and repairs. The mechanical design also allows replacement of the major circuit boards in the card cage without requiring an authorized service technician.

The components of the mechanical package are:

1. Faceplate assembly.
2. Baseplate assembly on which are mounted the brushless dc spindle motor, the Rotary Actuator and Optics Module, cartridge receiver assembly, and encoder preamplifier board.
3. Chassis assembly on which the baseplate assembly is mounted through four isolation mounts, the card cage assembly, and the Read/Write 1 Board.
4. The card cage assembly, which contains the motherboard, Read/Write 2, Low Power Servo, High Power Servo, Drive Sync, Drive Control, EDAC Functions (optional) and SCSI Controller (optional) Boards.
5. Power supply assembly (optional).
6. Slides (optional).

1.3.2. Optics Module

The primary function of the Optics Module is to record and retrieve data from the optical disk. The disk is 12 inches in diameter and contains a recordable-sensitive layer which resides on the second surface of a glass or plastic substrate. The Optics Module contains two electromechanical servos which maintain radial tracking and focus within specified tolerances.

The optical elements within the Optics Module collect light (830 nanometer nominal wavelength) emitted from a solid-state laser diode. The elements correct light beam aberrations and route the beam to the final objective lens. The final objective lens is part of a two-axis servomechanism which: 1) translationally moves the beam to maintain tracking and 2) maintains focus on the sensitive layer of the disk.

1.3.3. Read Operations

During a read operation, the laser illuminates the disk with laser light at a low power level (about 1.0 milliwatts at the first surface of the disk), which is reflected back to the detectors in the Optics Module. The preformatted data and any data written on the disk cause the reflected light to be amplitude modulated. The current output from the detectors is proportional to the power level of the reflected light which strikes them. The preamplifier on the Optics Module converts the current to voltage and passes the signal to

the Read/Write 1 Board. The Read/Write 1 Board separates the read data from the focus error and tracking signals. It also converts all the signals to standardized levels and directs them to the Read/Write 2 Board.

After being stabilized and digitized by the Read/Write 2 Board, the read data is sent to both the Drive Sync and the Drive Control Boards. The Drive Sync Board synchronizes the read clock with the read data and sends the clock to the Optical Drive Interface (ODI). These two signals are then converted into eight-bit parallel data by the SCSI Controller.

1.3.4. Write Operations

During a write operation, the data is processed in reverse order from the read. Serialized data is sent from the SCSI Controller Board through the ODI to the Drive Control Board and to the Read/Write 2 Board, then to the Read/Write 1 Board, and to the Optics Module. The laser is increased to a high power level 7 to 10 milliwatts at the first surface of the disk, to create a permanent change in the sensitive layer of the disk.

1.3.5. Positioning Servos

The focus and tracking necessary to maintain precise positioning of the beam are performed by the Two-Axis Actuator and the Low-Power Servo Board. The Two-Axis Actuator moves the objective lens radially, to maintain tracking under the control of the Low-Power Servo. The Two-Axis Actuator also moves the objective lens up and down to keep the beam focused on the sensitive layer. The reflected light is fed back, yielding a focus error signal which determines the direction in which the lens is moved.

The coarse positioning system consists of the Rotary Actuator and the High-Power Servo Board. The Rotary Actuator works with the Two-Axis Actuator to perform seeks. If only a short seek is required, the Two-Axis Actuator directly moves the beam to the specified track. If a longer seek is required, the Two-Axis Actuator is held in its radial axis at its central position and the Rotary Actuator moves the Optics Module to a location close to the specified track. During a long seek, position feedback is obtained from an optical scale mounted on the Rotary Actuator. The Two-Axis Actuator is then released in its radial axis and the Tracking Servo positions the beam so that an address can be read from the disk. The Drive Control uses this address information to compute a correction, causing the Two-Axis Actuator to make a series of short seeks to locate the beam on the correct track. Once the Two-Axis Actuator has acquired tracking, the Rotary Actuator Servo loop is switched from the optical scale to the same feedback signal as the Two-Axis Actuator. This means that the Rotary Actuator tries to maintain a position centered around the travel of the Two-Axis Actuator.

The High Power Servo Board also controls the spindle speed of the Brushless DC Spindle Motor which rotates the disk. The spindle speed feedback is obtained from an LED-photodiode pair which operates in the reflective mode. The LED emits a focused beam of light to the encoder band on the disk which modulates the beam and then reflects it back to the photodiode. The frequency of modulation provides feedback to the spindle speed control circuit.

1.3.6. Drive Control

The Drive Control executes operations requested through the ODI Bus or Operator Control Panel. By sampling drive status signals provided by other functions in the drive, the Drive Control detects any fault conditions and provides status and fault information to the controller. In addition, it tests ODI commands and sequences to eliminate illegal combinations.

When the drive is powered on, the microprocessor on the Drive Control performs a limited self-test prior to conducting a system initialization. The initialization includes calibrating the Rotary Actuator and bringing the drive to a predetermined initial state.

The Drive Control is also used to perform diagnostics when faults must be isolated.

1.4. Drive Interfaces

The Optimem Drive Interface (ODI) and the Small Computer System Interface (SCSI) provide the communication paths between the Optimem 1000 and the controller and host computer.

The ODI provides the SCSI Controller access to a number of primitive optical drive functions including seek and laser write control. Serial data is transferred across the ODI to the Controller synchronously in NRZ form using one common clock for both reading and writing.

The SCSI provided by the Optimem SCSI Controller working in conjunction with the Error Detection and Correction (EDAC) function, provides error-corrected asynchronous eight-bit parallel data in compliance with the ANSC X3T9.2 SCSI specification.

SECTION II

2. INSTALLATION

2.1. Unpacking the Drive

Position the carton correctly and open it from the top. Keep the packaging material for use in future shipments. Upon removal from packaging, inspect the drive for possible damage. Refer to Figure 2-1 before proceeding.

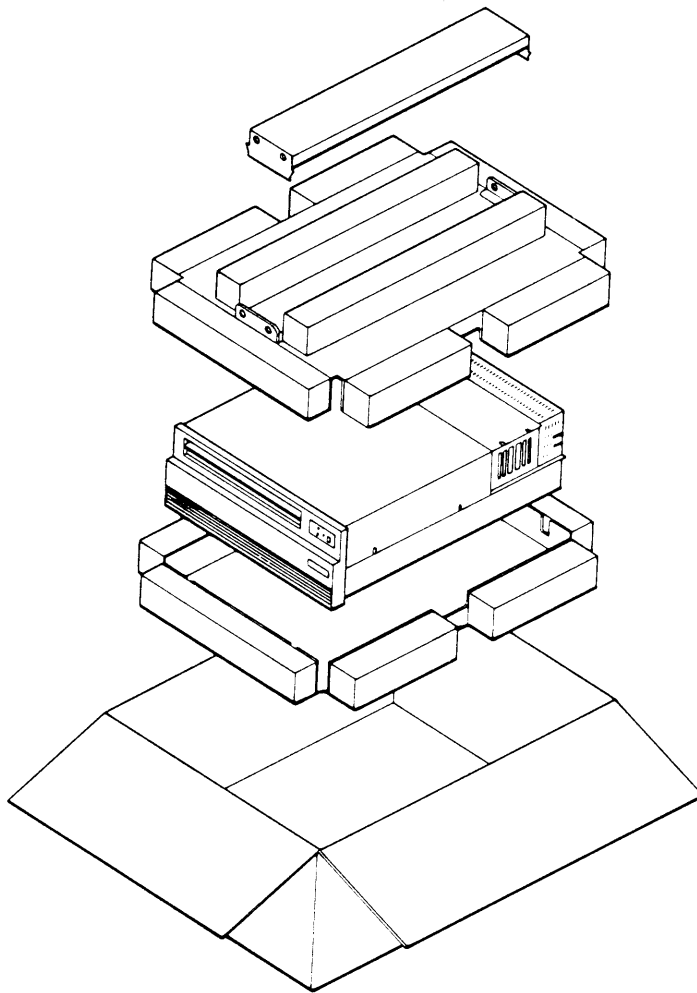

Fig. 2-1: Unpacking the Drive

2.2. AC Power Connection

The drive is set up and shipped with 115 Vac power unless 230 Vac is requested. A standard three prong IEC equipment cord is required to connect the power.

2.3. On/Off Switch and Fuse

The On/Off switch (at the rear of the drive) is for the ac power. Do not confuse the On/Off switch with the Start/Stop switch on the front panel.

The fuse must be properly sized for the voltage level selected. See Appendix Power Supply Configuration. The standard fuse carrier (Schurter PN FEK 031-1666) is gray and is for a 0.5 inch by 1.5 inch fuse. A metric fuse carrier (Schurter PN FEK 031-1663), which is black, is available for 5 mm by 20 mm fuses. Refer to Figure 2-2 which illustrates the On/Off switch, fuse, and power connector located at the rear of the drive.

2.4. Mounting the Drive

The drive is designed for use in a standard 19-inch rack. The recommended procedure is to mount the slides in the rack, then mount the drive to the slides. If a desktop enclosure is to be used, please consult the section on air flow requirements.

2.4.1. Mounting Holes for Slides

The mounting hole locations for the drive are shown in Figure 2-3. The same hole locations apply to the slides.

2.4.2. Stand Alone Enclosure

If a desktop enclosure is used with the drive, make certain the air flow requirements are met. Also, note that the front panel extends below the chassis; the enclosure must accommodate this feature. In order to meet the shock specification, the drive should be mounted in the enclosure using the eight mounting holes on the drive.

2.4.3. Air Flow Requirements

When mounting the drive or putting it in an enclosure, the air flow must not be restricted near the intake or outlet. When the drive is viewed from the front panel, the airflow moves from left to right through the card cage. The area at each side of the enclosure by the card cage should be at least fifty percent open for twenty-five square inches to provide adequate intake and exhaust airflow.

When a drive is installed, the customer or user should be advised not to restrict the space around the intake and outlet.

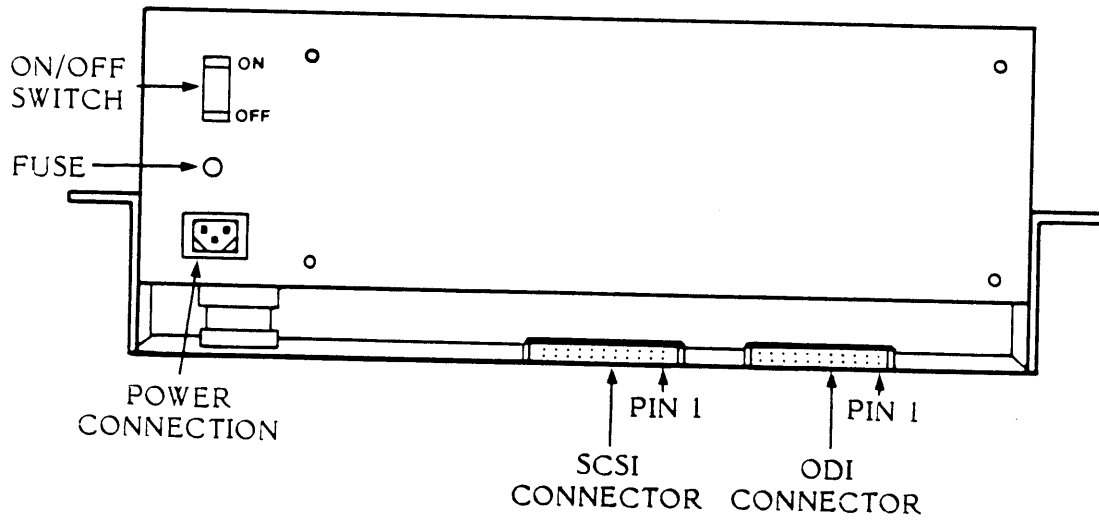

Fig. 2-2: Rear View of the Drive

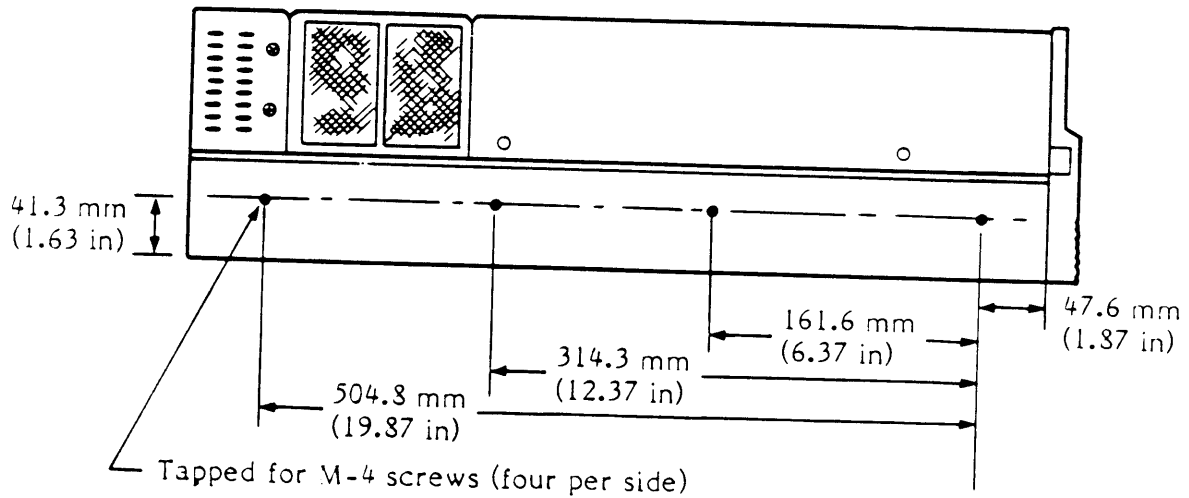

Fig. 2-3: Mounting Holes

2.5. Connecting the Drive

2.5.1. Description

A drive purchased with the controller and power supply needs the following connected: the ac power and an SCSI cable installed between the SCSI connector on the drive and the host system.

The controller uses a single-ended driver/receiver interface, which is intended for OEM applications, where all interface cabling will occur in properly shielded enclosures. All SCSI Devices on the SCSI Bus must be of the same driver/receiver type.

2.5.2. Transmitter Characteristics

All transmitters use open collector or three state drivers. Each signal driven by an SCSI Device has the following output characteristics when measured at the cable connector:

True = Signal Assertion = 0.0 VDC to 0.4 VDC.
Maximum driver output capability = 48 mA sinking at 0.5 VDC.
False = Signal Negation = 2.5 VDC to 5.25 VDC.

2.5.3. Receiver Characteristics

Each signal received by an SCSI Device has the following output characteristics when measured at the cable connector:

True = Signal Assertion = 0.0 VDC to 0.8 VDC.
Maximum total input load = -0.4 mA at 0.4 VDC.
False = Signal Negation = 2.0 VDC to 5.25 VDC.
Maximum input hysteresis shall be 0.2 VDC.

2.5.4. Cable Requirements

A 50 conductor shielded cable is required to meet the FCC regulations for a Class A computer device as stated in Part 15 Subpart J. The 3M Scotchflex cable part number 3517/50 will meet this requirement as long as the shield is grounded to the chassis with the cable clamp provided with the drive. The maximum cable length for the SCSI and ODI is six meters each.

2.5.5. Termination

All assigned signal lines are terminated with 220 ohms to +5 Vdc (nominal) and 330 ohms to ground at each end of the cable, as shown in Figure 2-4.

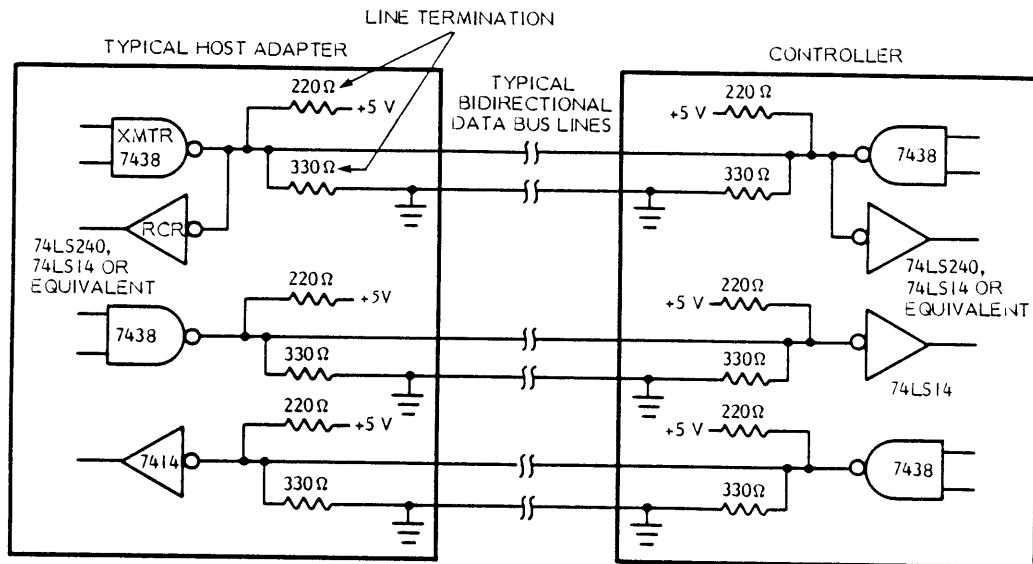

Fig. 2-4: Host Adapter to Optical Disk Controller Line Termination (Single-Ended Driver/Receiver Configuration)

SCSI

Termination is required on each end of the SCSI Bus to assure proper signal levels. If multiple SCSI devices are used then termination must be removed from all SCSI devices except those at each end of the SCSI Bus. The terminators on the SCSI Controller Board are located at H2 and J2.

ODI

Termination is required on each end of the ODI Bus to assure proper signal levels. One termination end consists of a resistor pack which resides permanently on the SCSI Controller Board at D1. The other termination which consists of a termination resistor pack and a terminator resistor are located on the Drive Control Board at locations R20 and D7.

If multiple slave drives are used they should be connected in daisy-chain fashion with a 50 pin cable to each ODI connector. Termination should be removed from all drives except for the drive at the end of the bus. This includes both terminator resistor and terminator pack on the Drive Control Board.

2.6. Connectors

The Optimem 1000 Optical Disk Drive SCSI header connector and ODI header connector are located on the motherboard at the rear of the drive. When viewed from the rear of the drive as depicted in Figure 2-2, the ODI connector is on the right and the SCSI connector is in the middle. Pin number one of each connector is on the upper right side of that connector.

The SCSI and ODI mating connectors are 50 conductor socket connectors which consist of two rows of 25 male pins on 0.10 inch centers. The 3M Scotchflex #3425-6000 meets this requirement.

The header connectors are a locking type. The mating connector profile should be such that it does not interfere with the locking tabs.

2.7. Interleave Selection

The controller has a selectable interleave of one (sectors read contiguously), or three (every third sector is read). The interleave is set by a jumper at location A6 on the SCSI Controller Board. If the jumper is removed the interleave is one; if the jumper is inserted the interleave is three.

2.8. Repacking the Drive

In the event the drive needs to be shipped, it should be packed in the original shipping container. The drive should be shipped with the cartridge removed and the power switch set to OFF. When the cartridge is removed from the drive, a lock automatically pins the Coarse Positioner to prevent movement of the Optics Module during shipment.

SECTION III

3. DRIVE OPERATIONS

3.1. Front Panel

The front panel has five LEDs to report status information to the operator and a switch to spin up or spin down the disk (as shown in Figure 3-1).

The Write Protect LED is an amber color; it reports the position of the Write Protect Tab on the cartridge. If the cartridge is write protected, the LED will be lit after the cartridge is inserted.

The Ready LED is green; it reports that the drive is in a ready state, that is, the disk is spun up and the drive is ready for operation.

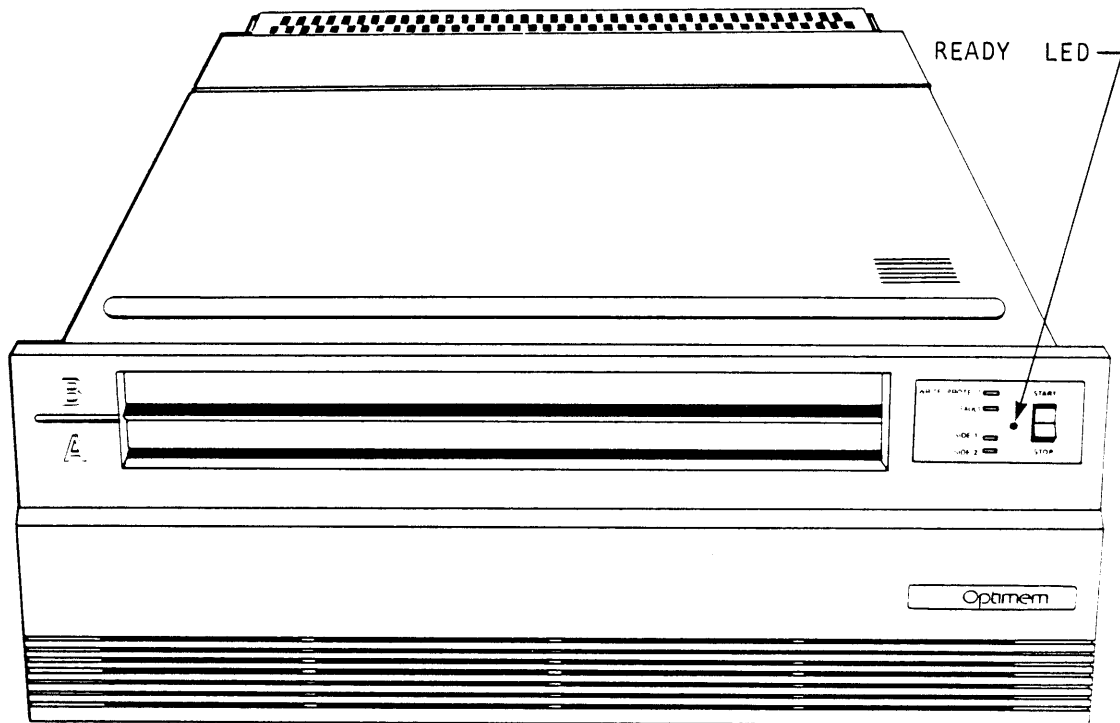

Fig. 3-1: Front Panel Configuration

The Fault LED is red; it reports the existence of a fault condition within the drive. A fault recovery procedure must be executed before the drive can be returned to the ready condition. Any transient fault is also reset when the disk is spun up. If the fault condition persists, an authorized service center should be contacted.

The Side 1/Side 2 LEDs are green; they report which side of the disk is being accessed. This information is displayed when the cartridge loading is complete (i.e., the cover has been inserted in the top slot: Slot B).

3.2. Characteristics of the Cartridge

3.2.1. Cartridge Components

The optical disk cartridge consists of a cover, a carrier, and a disk (see Figure 3-2). When the carrier is inserted in the cover, the only visible part of the carrier is the dark gray, finned portion on the beveled end of the cartridge (see Figure 3-3).

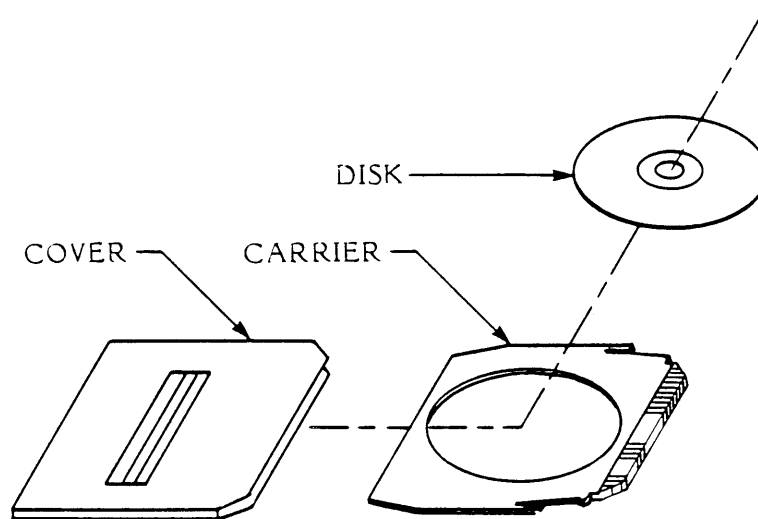

Fig. 3-2: Optical Disk Cartridge Components

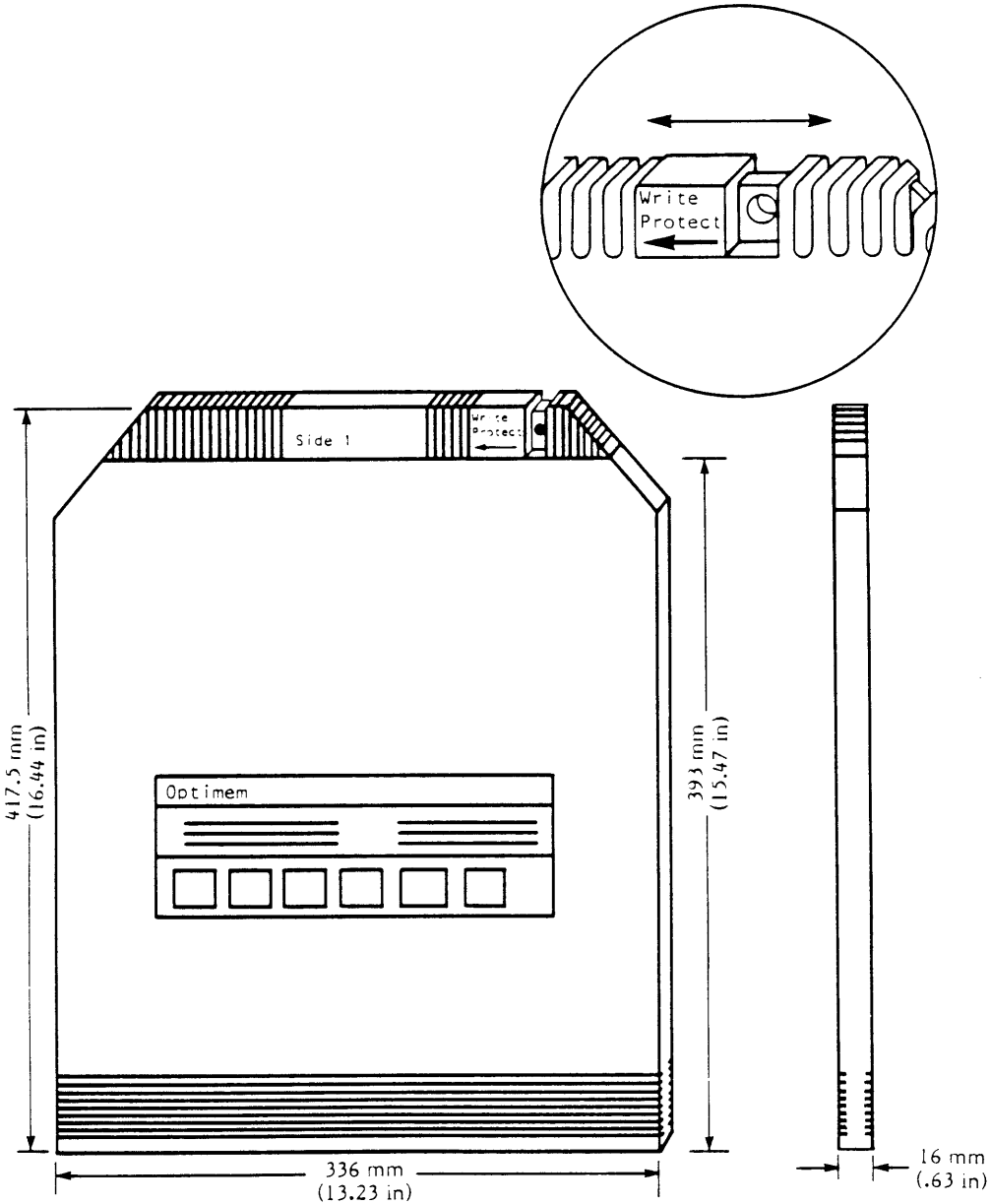

Fig. 3-3: Optical Disk Cartridge: Dimensions and Write Protect

3.2.2. Write Protect

The write protect feature consists of a sliding tab on the finned portion of the carrier. Write protect is enabled by moving the tab in the direction of the arrow on the tab to expose a hole. To enable a write, slide the tab back to cover the hole. The tab has a detent; be sure to move it completely to the desired position. See Figure 3-3.

3.2.3. Empty Cartridge

Never insert an empty cartridge (a cover) in Slot B of the drive unless a carrier is loaded in Slot A (see Figure 3-4, Step 4).

3.2.4. Side 1 - Side 2

Cartridges are single-sided or double-sided. They are easily distinguished by the labels on the exposed end of the carrier and by the write protect tabs. The single-sided cartridge is labeled Side 1. The double-sided cartridge is labeled Side 1 on the top and Side 2 on the bottom. The double-sided cartridge also has two write protect tabs, while the single-sided has only one.

3.3. Loading the Cartridge

**WHEN LOADING THE CARTRIDGE, PLEASE EXECUTE ALL FIVE STEPS IN ORDER.
REFER TO FIGURE 3-4 BEFORE PROCEEDING FURTHER.**

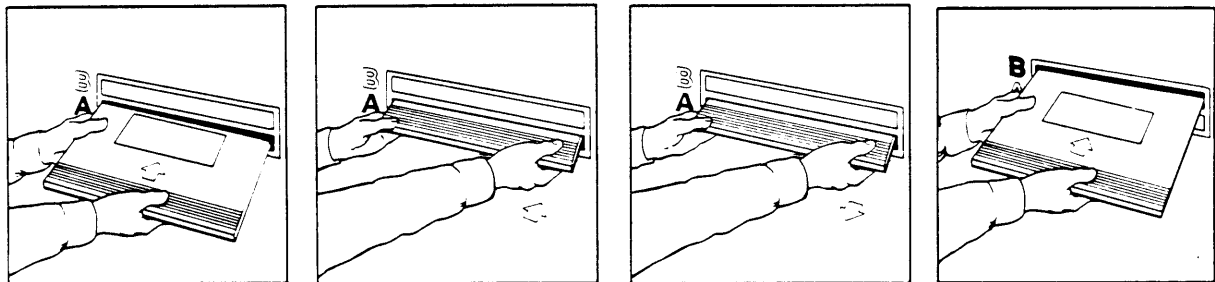
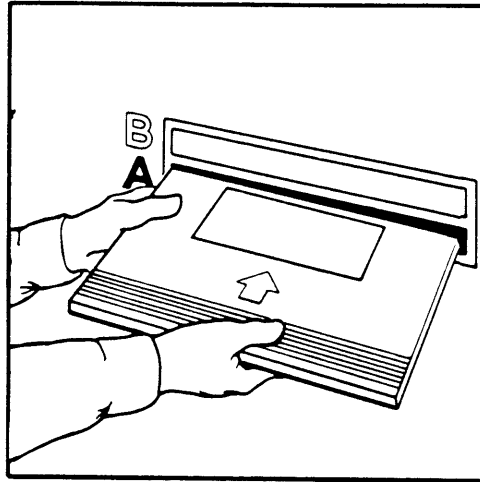
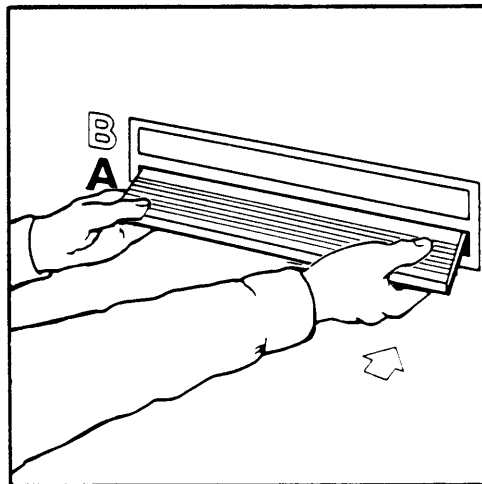

Fig. 3-4: Loading the Cartridge

Step One:

Check the Start/Stop switch. It must be in the Stop position. Grasp the cartridge firmly in both hands and align it in the plane of the drive with Slot A.

Step Two:

Gently, but firmly, insert the cartridge in Slot A with one smooth motion until the cartridge engages the stops. If the cartridge is not completely inserted, the carrier will not be retained. Once the cartridge is inserted, steps Three and Four must be completed before trying to unload it.

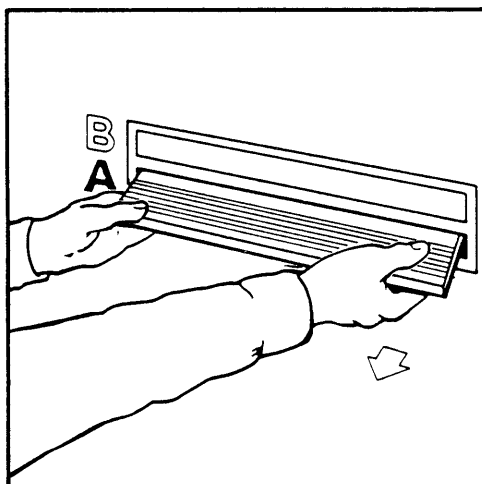
Step Three:

Pull outward on the cartridge in one smooth motion. If the cartridge was inserted properly, only the cover will be removed. If the carrier is still in the cartridge, start the loading process over at step one.

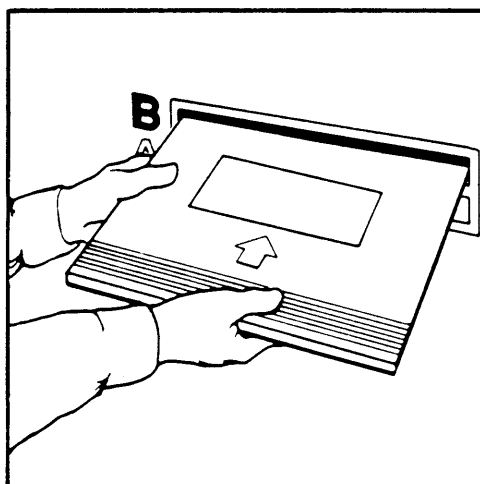
Step Four:

Grasp the cover firmly in both hands and align it in the plane of the drive with Slot B. Gently, but firmly, insert the cover in Slot B with one smooth motion until the cover engages the stops. If the cover is not completely inserted, the carrier will not be loaded properly on the spindle and the drive will not start.

Step Five:

The drive must go through a spin up procedure before it is ready for use. This can be done manually by pushing the switch on the front panel to start or by issuing a START/STOP UNIT command from the Initiator (computer). The Ready LED will begin pulsing until the drive is ready, at which time it will emit a steady green light. The Side LEDs on the panel will also indicate whether Side 1 or Side 2 is loaded.

3.4. Unloading the Cartridge

**WHEN UNLOADING THE CARTRIDGE, USE PROCEDURE SHOWN IN FIGURE 3-5.
REFER TO FIGURE 3-5 BEFORE PROCEEDING FURTHER.**

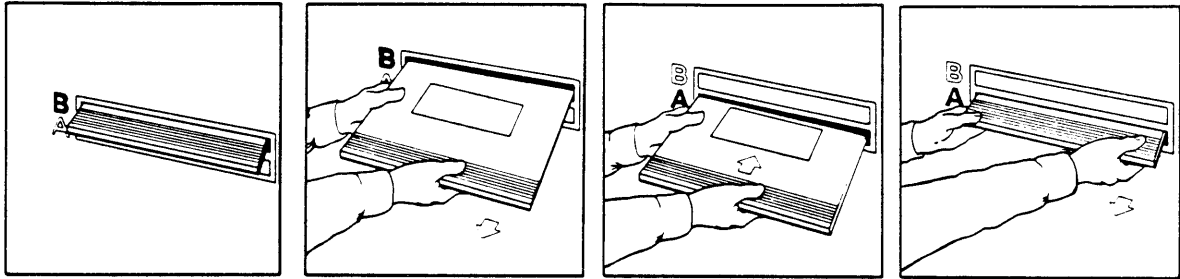
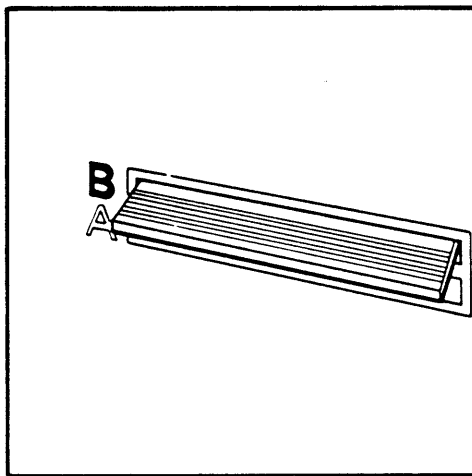
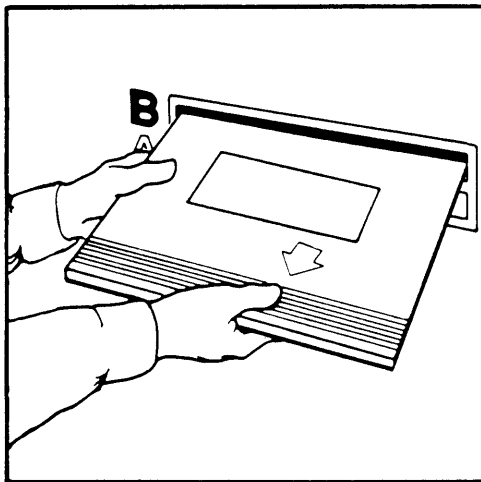

Fig. 3-5: Unloading the Cartridge

Step One:



The drive must be spun down before you remove the cartridge. This can be done manually by pushing the switch on the front panel or by issuing a SPIN DOWN command from the Initiator. The Ready LED will pulse until the drive spin down is complete, at which time it will remain off. Do not proceed until this condition is reached.

Step Two:

Grasp the cover in Slot B with both hands and firmly, but gently, pull outward until the cover is removed from the drive.

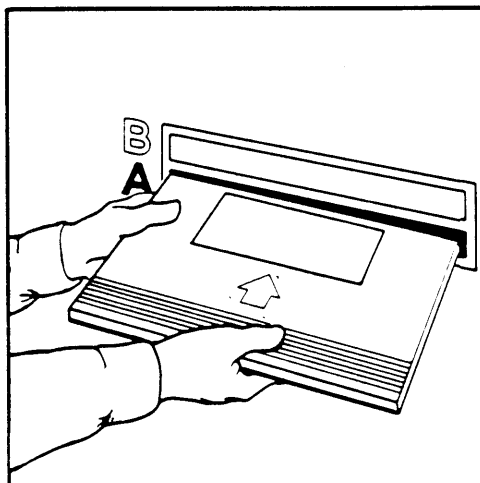
Step Three:

Align the cover in the plane of the drive with Slot A and insert it with one motion until it engages the stops.

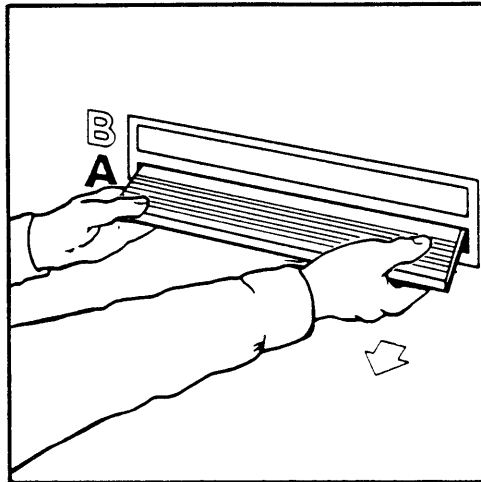
Step Four:

Grasp the cartridge in Slot A with both hands and firmly, but gently, pull outward to remove the cartridge. If the carrier is not retained in the cover, repeat this procedure from Step Three.

Never insert a cover in Slot A unless a carrier is in place.

Step Five:

Store the cartridge in an appropriate location.

3.5. Spin Up/Spin Down

Spin up is the process by which a loaded cartridge is made ready for use. The drive engages the disk and accelerates it to operating speed. This process takes no more than fifteen seconds. During this time, the drive also performs an internal diagnostic to verify that no unsafe conditions exist and that the drive is functional. When the Ready LED stops pulsing and emits a steady green light, the drive is ready for use. If there is an unsafe condition in the drive, the Fault LED will be lit.

Spin down is the process by which a drive is brought to standby mode so that a cartridge may be removed. This process takes no more than fifteen seconds, and is completed when the Ready LED stops pulsing and remains unlit.

There is a Start/Stop switch on the front panel for manually performing a spin up or spin down. Placing the switch in the Start position begins the spin up process, provided a cartridge has been properly loaded. Placing the switch in

the Stop position begins the spin down process.

An alternative approach is to use the START/STOP UNIT command. This command is issued by an Initiator to the SCSI Controller. If the drive is spun up with the START/STOP UNIT command, the Start/Stop switch cannot be used to spin down the drive. Alternatively, if the drive is spun up manually via the Start/Stop switch, it cannot be spun down by issuing the START/STOP UNIT command.

3.6. Cartridge Cautions

3.6.1. Impact

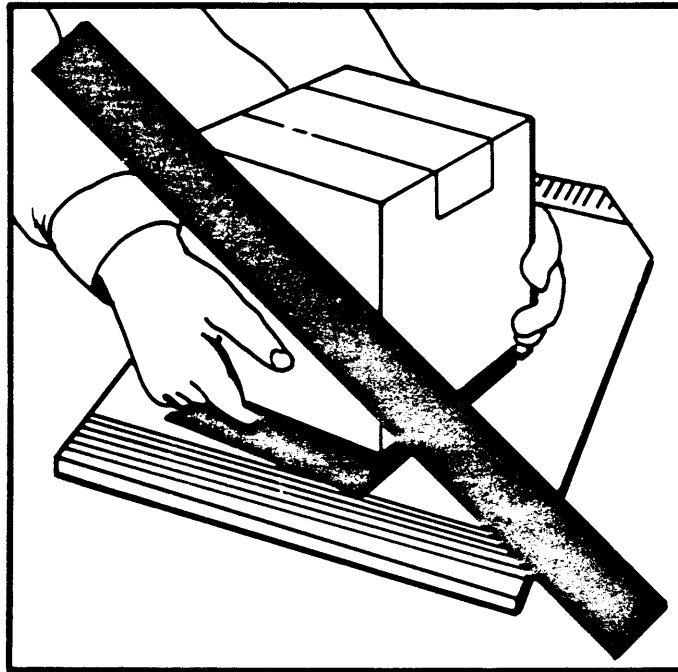

Fig. 3-6: Protecting the Cartridge

Do not drop the cartridge or set objects on it. See Figure 3-6.

A severe impact to the cartridge could result in internal damage that renders the disk inoperable.

The cartridge should be adequately packed for shipment.

3.6.2. Temperature

The ambient operating temperature of the disk ranges from 10° to 43° C, allowing for a 6° rise within an operational drive. For storage and transit, the temperature range is -40° to 60° C. The cartridge must be within operating temperature range for one hour before using. The temperature gradient should not exceed 10° C per hour. Exceeding these specifications may damage the disk.

A temperature-sensitive label on the cartridge is visible from the beveled end. If this has turned black, the cartridge has been exposed to a temperature beyond the limits specified. Refer to Figure 3-7.

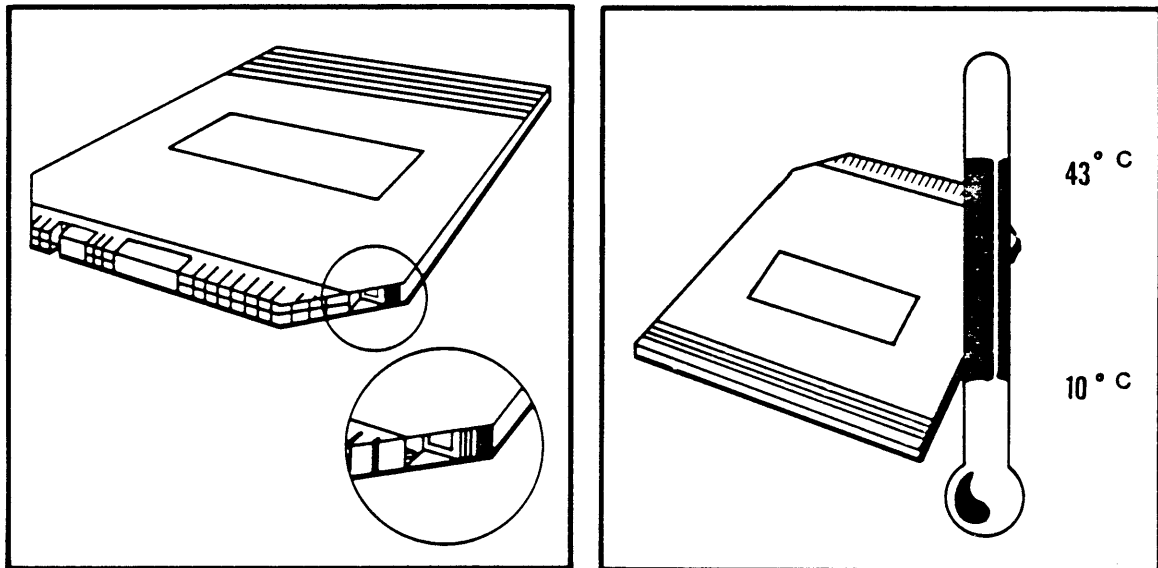

Fig. 3-7: Temperature Range and Limits for Cartridge Operation

3.6.3. Humidity

The relative humidity range is 10% to 90%, with the gradient not exceeding 20% per hour. The maximum wet bulb temperature is 26.6 degree C.

3.6.4. Storage

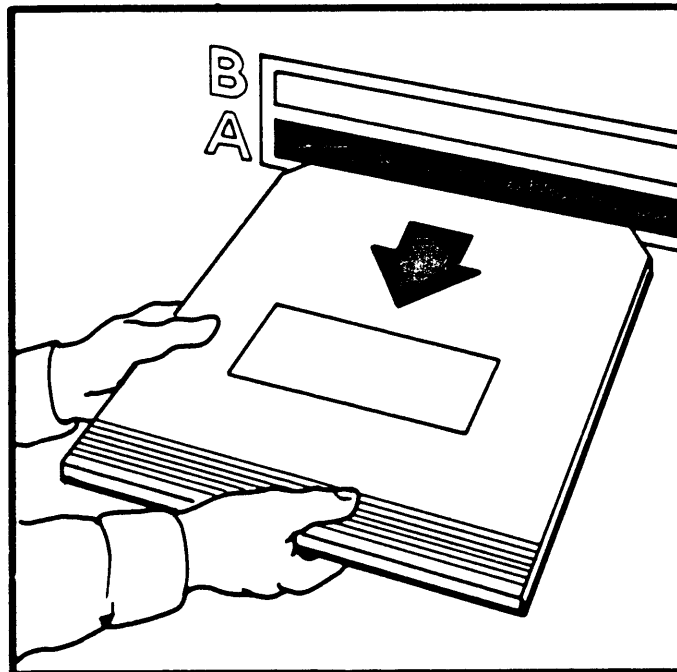

Fig. 3-8: Removing the Cartridge When Not in Use

As indicated in Figure 3-8, the cartridge should always be removed from the drive when not in use.

The cartridge storage requirements are:

Temperature	-40° to 60° C
Humidity	10% to 90% relative humidity (noncondensing)
Altitude	-300 to 3600 meters

The cartridge should not be exposed to excessive sunlight or sudden changes in environment.

3.7. Damaged Cartridges

In the event that a cartridge is damaged, the recommended recovery varies upon the extent and location of the damage.

Never insert a damaged cartridge in the drive; pieces may break off and interfere with the drive operation.

If the cover is damaged, a new cover can be installed over the existing carrier. Viewing the cartridge from the beveled end, look into the square holes on each side. A hook is visible within each hole. Gently lift both of these hooks to release the cover from the carrier. Do not touch the disk while it is exposed. Slide a new cover over the carrier.

If the carrier is damaged, it is recommended that the cartridge be returned to an authorized service center for replacement.

If the disk is damaged, the cartridge must be returned for evaluation of the damage.

SECTION IV

4. SCSI CONTROLLER

4.1. OVERVIEW OF SCSI

The Small Computer System Interface (SCSI) is the result of an ANSC project whose aim was to provide an interface capable of interconnecting multiple small computers and peripherals. The interface has been designed for device independence. Device independence allows new peripherals, such as the Optimem 1000 Optical Disk Drive, to be easily integrated into an existing computer system without major hardware or software development projects.

4.2. Reference Documents

4.2.1. ANSC Specification

The working draft proposal for the Small Computer System Interface is an ANSC X3T9.2 document. It is recommended that a copy of this document be obtained for reference. Not all the commands or phases listed in the X3T9.2 document pertain to the Optimem 1000 SCSI Controller. The information in this manual supercedes any information supplied in the X3T9.2 document.

4.2.2. The Optimem 1000 Interface Document

Be aware that, although the Optimem 1000 SCSI Controller was designed to be an SCSI Device, many features are dependent on the implementation for a particular peripheral device. Please refer to the Optimem 1000 Interface Document for specifics on the Optimem implementation of SCSI.

4.3. Theory of SCSI

SCSI (Small Computer System Interface) is an eight-bit, bi-directional, parallel interface. The interface provides host computers with device independence within a class of devices. By using a standard 50-pin cable and a generic set of high-level commands, hardware and software installation of additional devices is greatly simplified.

The SCSI interface uses a logical, rather than a physical, address data structure. In the Optimem 1000 Drive, the blocks are sequentially addressed from logical block 0 through logical block 999,999. Each block is accessed by specifying its logical address in a seek, read or write command.

The SCSI is intended to be a system level (rather than device level) interface. Examples of device level interfaces are: SA1000, ST506 and QIC-02. With a device level interface, the system integrator must develop a unique set of software and hardware to deal with each device. The SCSI allows all devices to communicate with the same command set and allows up to eight SCSI Devices in any combination of Initiators and Targets on the interface. Each Target SCSI Device is allowed eight attached peripherals, enabling one

Initiator to theoretically attach 56 peripheral devices.

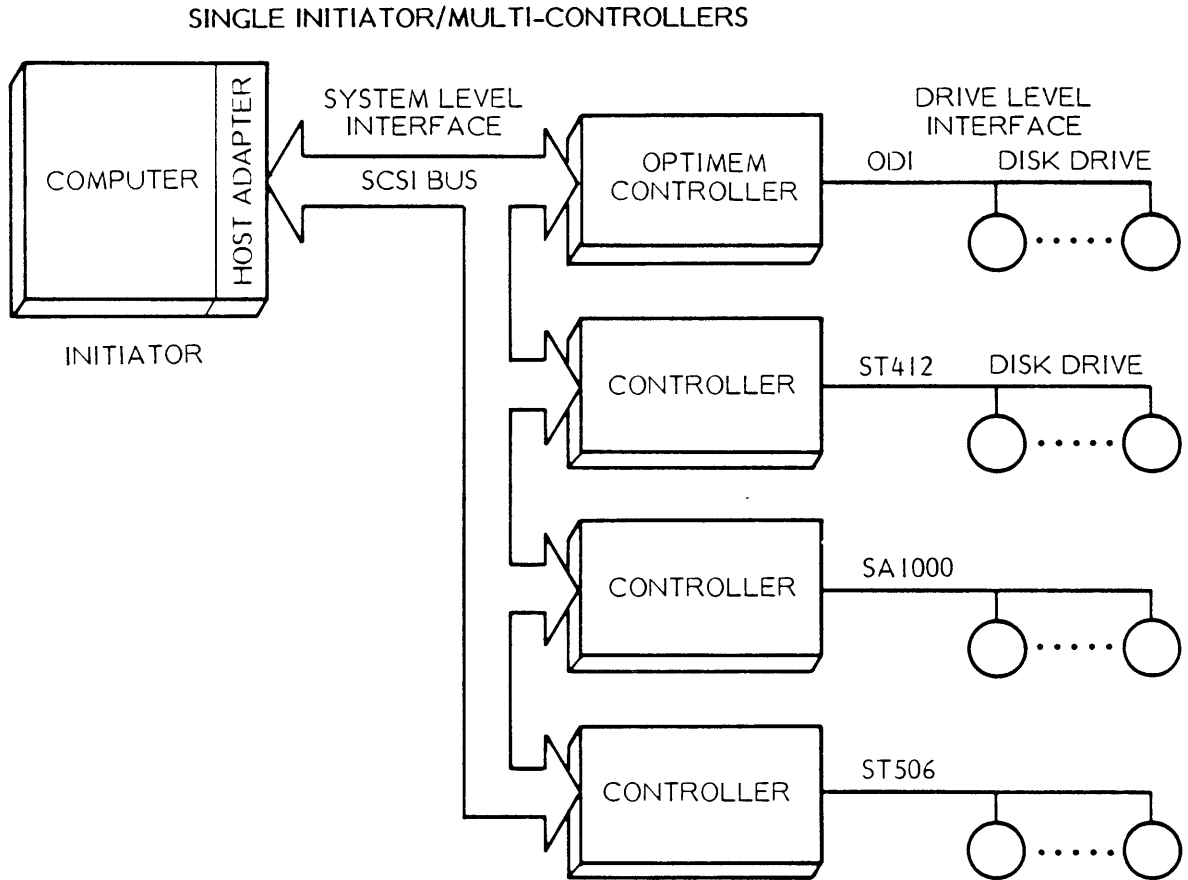

Fig. 4-1: SCSI System Configuration

4.4. Performance Specifications

The Optimem 1000 SCSI Controller meets the following capacity specifications in the Error Detection and Correction (EDAC) mode format.

Table 4-1: Capacity Specification in the EDAC Mode

UNIT	CAPACITY
Block Size(User)	1024 Bytes
Blocks per Track	25
Tracks per surface	40000
Total Capacity	one million 1024 byte blocks one gigabyte
Buffer Size	4096 Bytes
Block Address Range	999,999 blocks (21 bit address) 999,999 blocks (32 bit address)
Transfer Length	256 blocks (Group 0 command) 64K blocks (Group 1 command)

4.5. Data Transfer Rates

Data transfer on the SCSI Bus is only asynchronous. Single ended drivers and receivers and a cable length of up to 6 meters are used. The maximum SCSI data transfer rate is 1.0 Mbyte per second. The sustained average data transfer, limited by the format overhead and error detection and correction, is 0.48 Mbytes per second.

4.6. Medium Defects

A medium defect is a physical characteristic of the medium which results in a repetitive read error. Medium defects are excluded from the error rate calculations. A repetitive read error is defined as a defect which is not corrected by the EDAC on a verification of a write operation without retrying the read.

4.7. Data Error Rates

Specified data error rates are obtained using error detection and correction functions, and retries of the read operation. The data error rates are valid only when the drive and controller are operated within specification. Data error rates due to equipment failures are excluded.

4.7.1. Recoverable Errors

A recoverable read error occurs when data can be read correctly within five retries using the EDAC functions. There will be no more than one recoverable read error in 10^{10} bits of data read. The controller will automatically do five retries if the DRT Bit is zero. See the MODE SELECT command.

4.7.2. Nonrecoverable Errors

A nonrecoverable read error occurs when data cannot be read correctly within five retries using the EDAC functions. There will be no more than one nonrecoverable read error in 10^{12} bits of data read.

4.7.3. Nondetected Errors

A nondetected read error may result from any of the following conditions:

- The EDAC not detecting an error which exists and reporting good data.
- The EDAC not properly correcting data and reporting the data as good.
- The EDAC reporting good data as bad.

There will be no more than one nondetected read error in 10^{16} bits of data read.

4.8. SCSI Bus

The SCSI Cable Pin Assignments are listed in Table 4-2.

Table 4-2: SCSI Cable Pin Assignments

Single-Ended Driver/Receiver Configuration

SIGNAL	PIN NUMBER	DESCRIPTION
-DB(0)	2	Data Bus Bit 0
-DB(1)	4	Data Bus Bit 1
-DB(2)	6	Data Bus Bit 2
-DB(3)	8	Data Bus Bit 3
-DB(4)	10	Data Bus Bit 4
-DB(5)	12	Data Bus Bit 5
-DB(6)	14	Data Bus Bit 6
-DB(7)	16	Data Bus Bit 7
-DB(P)	18	Data Bus Parity Bit
GROUND	20	Ground
GROUND	22	Ground
GROUND	24	Ground
TERMPWR	26	Terminator Power
GROUND	28	Ground
GROUND	30	Ground
-ATN	32	Attention
-GROUND	34	Ground
-BSY	36	Busy
-ACK	38	Acknowledge
-RST	40	Reset
-MSG	42	Message
-SEL	44	Select
-C/D	46	Control/Data
-REQ	48	Request
-I/O	50	Input/Output

Note: All signals are low true. All odd pins except pin 25 are connected to ground. Pins 25 and 26 are open.

When two SCSI devices communicate, one acts as the Initiator and the other acts as the Target. The Target is defined in this document as the Optimem 1000 SCSI Controller. The following bus signals are used to communicate a desired operation between the Initiator and Target.

BSY (BUSY)	An "or-tied" signal which indicates that the SCSI Bus is being used.
SEL (SELECT)	A signal used by an Initiator to select a Target or by a Target to reselect an Initiator.
C/D (CONTROL/DATA)	A signal driven by a Target which indicates whether control or data information is on the DATA BUS. Asserted indicates control.
I/O (INPUT/OUTPUT)	A signal driven by a Target which controls the direction of data movement on the DATA BUS with respect to an Initiator. Asserted indicates input to the Initiator.
MSG (MESSAGE)	A signal driven by a Target during the MESSAGE phase.
REQ (REQUEST)	A signal driven by a Target to indicate a request for a REQ/ACK data transfer handshake.
ACK (ACKNOWLEDGE)	A signal driven by an Initiator to indicate an acknowledgment for a REQ/ACK data transfer handshake.
ATN (ATTENTION)	A signal driven by an Initiator to indicate an Attention Condition. This signal is not implemented in the Optimem 1000 SCSI Controller.
RST (RESET)	An "or-tied" signal driven by an Initiator to indicate the Reset Condition.
DB(7-0,P) (DATA BUS)	<p>Eight data bit signals plus a parity bit signal which form a DATA BUS. DB(7) is the most significant bit. Bit number, significance, and priority decrease downward to DB(0).</p> <p>Each of the eight data signals DB(7) through DB(0) is uniquely assigned as a Target's or Initiator's SCSI Device ID.</p>

The signals BSY and RST are "or'ed" because they may be simultaneously driven by more than one SCSI Device.

4.9. SCSI Bus Phases

The SCSI bus has eight operational phases:

- | | | | |
|----|-------------|---------|-------------------------|
| 1. | BUS FREE | | |
| 2. | ARBITRATION | | |
| 3. | SELECTION | | |
| 4. | RESELECTION | | |
| 5. | COMMAND |]-----[| INFORMATION
TRANSFER |
| 6. | DATA | | |
| 7. | STATUS | | |
| 8. | MESSAGE | | |

The SCSI Bus can never be in more than one phase at any given time.

4.9.1. BUS FREE Phase

The BUS FREE phase is used to indicate that no Device is currently using the SCSI Bus and therefore the Bus is available for subsequent users.

4.9.2. ARBITRATION Phase

The ARBITRATION phase is not implemented in the Optimem 1000 SCSI Controller.

4.9.3. SELECTION Phase

The SELECTION phase allows the Initiator to select a Target in order to begin the execution of commands.

4.9.4. RESELECTION Phase

The RESELECTION phase is not implemented in the Optimem 1000 SCSI Controller.

4.9.5. COMMAND Phase

The COMMAND phase allows the Target to request command information from the Initiator.

4.9.6. DATA Phase

The term, DATA phase, encompasses both the DATA IN and the DATA OUT phases.

The DATA IN phase allows the Target (controller) to request that data be sent to the Initiator from the Target.

The DATA OUT phase allows the Target (controller) to request that data be sent

from the Initiator to the Target.

4.9.7. STATUS Phase

The STATUS phase allows the Target to request that status information be sent from the Target to the Initiator.

4.9.8. MESSAGE Phase

The term, MESSAGE phase, refers to either a MESSAGE IN or a MESSAGE OUT phase. The first byte transferred in either of these phases is either a single byte message or the first byte of a multiple byte message. Multiple byte messages are wholly contained within a single MESSAGE phase.

The message system allows communication between an Initiator and Target for the purpose of physical path management. The Optimem 1000 SCSI Controller implements only the Message In Phase.

The MESSAGE IN phase allows the Target to request that messages be sent to the Initiator from the Target.

The MESSAGE OUT phase is not implemented in the Optimem 1000 SCSI Controller.

4.9.9. Phase Sequencing

The order in which phases are used follows a prescribed sequence. In all systems, the Reset Condition can abort any phase and is always followed by a BUS FREE phase. Also, the BUS FREE phase can follow any other phase.

The permissible phase sequencing in the Optimem 1000 is shown in Figure 4-2.

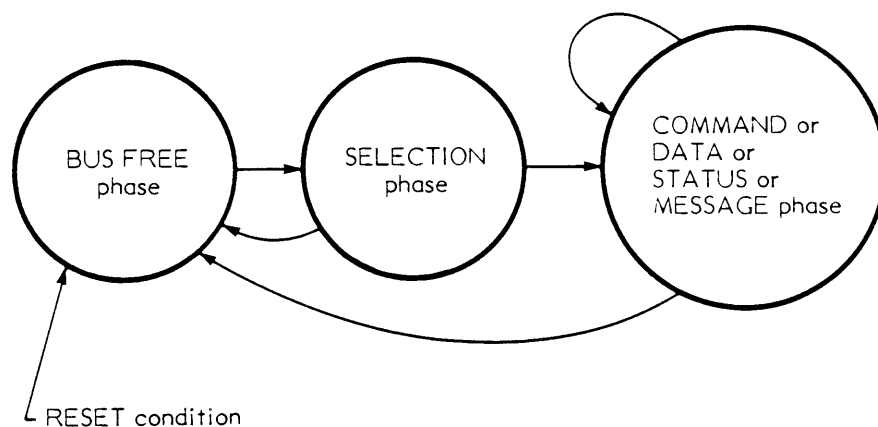

Fig. 4-2: Optimem 1000 Phase Sequencing

4.10. Commands

4.10.1. Command Descriptor Block

A request to a peripheral device is performed by sending a command in the form of a Command Descriptor Block (CDB) to the Target. A CDB has the Command Operation Code as the first byte, typically followed by a Logical Unit Number, a Logical Block Address, a Transfer Length, and a Control Byte. The Control Byte is not implemented in the Optimem 1000 Controller. Refer to Figure 4-3 and 4-4 which illustrate typical Optimem six-byte and ten-byte command descriptor blocks.

BIT BYTE	7	6	5	4	3	2	1	0
0	Operation Code							
1	Logical Unit Number			Logical Block Address bits if required (MSB)				
2	Logical Block Address if required							
3	Logical Block Address if required (LSB)							
4	Transfer Length if required							
5	Control Byte							

Fig. 4-3: Typical Command Descriptor Block for Six-Byte Commands

BIT BYTE	7	6	5	4	3	2	1	0
0	Operation Code							
1	Logical Unit Number			RESERVED				
2	Logical Block Address if required (MSB)							
3	Logical Block Address if required							
4	Logical Block Address if required							
5	Logical Block Address if required (LSB)							
6	RESERVED							
7	Transfer Length if required (MSB)							
8	Transfer Length if required (LSB)							
9	Control Byte							

Fig. 4-4: Typical Command Descriptor Block for Ten-Byte Commands

4.10.2. Operation Code

The Operation Code of the CDB has a Group Code field and a Command Code field. The three-bit Group Code Field provides for eight groups of command codes. The five-bit Command Code Field provides for thirty-two command codes. Thus, a total of 256 possible Operation Codes exist.

Three Group Codes are implemented in the Optimem 1000 SCSI Controller:

```

Group 0    6-Byte Commands
Group 1   10-Byte Commands
Group 7   10-Byte Diagnostic Commands

```

The Operation Codes (Commands) implemented in the Optimem 1000 SCSI Controller are summarized in Table 4-3.

Table 4-3: Summary of Commands Implemented

Group 0		Group 1		Group 7	
Code	Description	Code	Description	Code	Description
00h	TEST UNIT READY	20h		E0h	
01h	REZERO UNIT	21h		E1h	
02h		22h		E2h	
03h	REQUEST SENSE	23h		E3h	
04h		24h		E4h	WRITE ODI BUS
05h		25h	READ CAPACITY	E5h	READ ODI BUS
06h		26h		E6h	READ DRIVE STATUS
07h		27h		E7h	
08h	READ	28h	READ	E8h	DIAGNOSTIC READ
09h		29h		E9h	
0Ah	WRITE	2Ah	WRITE	EAh	DIAGNOSTIC WRITE
0Bh	SEEK	2Bh		EBh	
0Ch		2Ch		ECh	
0Dh		2Dh		EDh	
0Eh		2Eh	WRITE AND VERIFY	EEh	
0Fh		2Fh	VERIFY	EFh	
10h		30h		F0h	
11h		31h		F1h	
12h	INQUIRY	32h		F2h	
13h		33h		F3h	
14h		34h		F4h	
15h	MODE SELECT	35h		F5h	
16h		36h		F6h	
17h		37h		F7h	
18h		38h		F8h	
19h		39h		F9h	
1Ah	MODE SENSE	3Ah		FAh	
1Bh	START/STOP UNIT	3Bh		FBh	
1Ch	RECEIVE DIAGNOSTIC	3Ch		FCh	
1Dh	SEND DIAGNOSTIC	3Dh		FDh	
1Eh		3Eh		FEh	
1Fh		3Fh		FFh	

4.10.3. Logical Unit Number

The Optimem SCSI controller communicates with a specific drive by using the designated Logical Unit Number (LUN) of that drive. Each controller can attach up to eight drives and therefore eight possible LUNs exist per controller.

4.10.4. Logical Block Address

Data is transferred across the SCSI Bus with a fixed block structure and a logical address scheme. The Logical Block Address begins with block zero and runs contiguously until the last accessible block on the medium.

Group 0 commands contain twenty-one bit starting block addresses, for an addressing range of up to two million blocks. Group 1 commands contain thirty-two bit starting block addresses for an extended addressing range of up to four billion blocks.

The logical block size of the Optimem Controller is 1024 bytes. The maximum Logical Block Address is 999,999 decimal.

4.10.5. Transfer Length

The Transfer Length specifies the number of blocks of data to be transferred.

The Group 0 commands use one byte to specify the Transfer Length. This allows up to 256 blocks of data to be transferred by one command. A byte value of 1 to 255 indicates that number of blocks will be transferred. A byte value of zero indicates 256 blocks will be transferred. Since the block size in the Optimem 1000 SCSI controller is 1024 bytes, a quarter megabyte of user data can be transferred with one Group 0 command.

The Group 1 commands use two bytes to specify the Transfer Length, allowing up to 65,535 blocks or 64 megabytes of data, to be transferred by one command. Unlike the Group 0 Commands, a value of zero indicates there is no data transfer.

4.10.6. Control Byte

The Control Byte is the last byte in all command descriptor blocks. The Control Byte is not implemented in the Optimem SCSI Controller and is set to zero by the Initiator for all commands.

4.10.7. Reserved Bits and Bytes

All bits and bytes designated RESERVED are set to zero by the Initiator.

4.10.8. Completion Status Byte

The Optimem 1000 SCSI Controller sends to the initiator a completion status for every command executed. Good status is returned in the Status Phase if the command completed successfully. A Check Condition is returned if a fault was encountered during execution of the command.

The STATUS phase is followed by a final MESSAGE phase. This consists of the COMMAND COMPLETE message sent to the Initiator.

A Check Condition status indicates an error, exception or abnormal condition occurred during execution of the command. Further information regarding this condition is returned to the initiator with a REQUEST SENSE command. In order to obtain valid error information, a REQUEST SENSE command must be issued immediately after a command is returned with a Check Condition status.

4.10.9. Completion Status Descriptions

GOOD	This status indicates that the operation was performed successfully.
CHECK CONDITION	This status is caused by any error, exception or abnormal condition which causes Sense Data to be set.
BUSY	This status indicates that the controller is busy and is therefore unable to accept a command from the Initiator.

SECTION V

5. OPTIMEM DRIVE INTERFACE (ODI)

5.1. Description

The Optimem Drive Interface (ODI) is the drive level interface of the Optimem 1000 Optical Disk Drive. The ODI provides the means to control the drive, report drive status, and write and read data.

The Optimem 1000 SCSI Controller allows up to eight drives to be attached through the ODI. This simplifies system integration where more than one drive is needed.

5.2. Definition of the ODI

The ODI uses a 50-conductor cable of which fourteen signals are driven by open collector drivers and three signal pairs are driven by differential drivers. Refer to Table 5-1.

5.3. ODI Bus Signals

CUB(7-0)	CONTROL UNIT BUS: Eight bi-directional signals used to send commands and receive status or messages. CUB(7) is the most significant bit. Bit number and significance decrease to CUB(0).
MS(2-0)	MODE SELECT: Three signals encoded to provide eight modes for output of commands and eight modes for input of status or messages (see Table 5-2).
MOE	MODE OUT ENABLE: A strobed signal is used to latch the command on the CONTROL UNIT BUS into the Drive Control Board. MODE OUT indicates flow from the controller to the drive.
MIE	MODE IN ENABLE: A signal line which, when asserted, requests the status byte be placed on the CONTROL UNIT BUS. The status or message is valid as long as MIE is active. MODE IN indicates flow from the drive to the controller.
SCTMRK	SECTOR MARK: A signal driven by the drive to indicate the beginning of each sector. The signal is valid for the duration of the preformat address field.
WRTDTA	WRITE DATA: A pair of differentially driven signals which transfer NRZ write data from the controller to the drive.
RDDTA	READ DATA: A pair of differentially driven signals which transfer NRZ read data from the drive to the controller.
RDCLK	READ CLOCK: A pair of differentially driven signals which transfer the five Mhz clock from the drive to the controller. The READ CLOCK signal is used for both reading and writing.

5.4. ODI Cable Pin Assignments

Table 5-1 shows the ODI cable pin assignments.

Pin numbers 1 through 40 are open-collector driven, with the odd-numbered pins connected to ground.

Table 5-1: ODI Cable Pin Assignments

ODI BUS SIGNAL	DESCRIPTION	PIN NUMBER	GROUND PIN
CUB(0)	Control Unit Bus Bit 0	2	1
CUB(1)	Control Unit Bus Bit 1	4	3
CUB(2)	Control Unit Bus Bit 2	6	5
CUB(3)	Control Unit Bus Bit 3	8	7
CUB(4)	Control Unit Bus Bit 4	10	9
CUB(5)	Control Unit Bus Bit 5	12	11
CUB(6)	Control Unit Bus Bit 6	14	13
CUB(7)	Control Unit Bus Bit 7	16	15
MS(0)	Mode Select Bit 0	18	17
MS(1)	Mode Select Bit 1	20	19
MS(2)	Mode Select Bit 2	22	21
RESERVED		24	23
MOE	Mode Out Enable	26	25
MIE	Mode In Enable	28	27
RESERVED		30	29
RESERVED		32	31
RESERVED		34	33
SCTMRK	Sector Mark	36	35
RESERVED		38	37
SPARE		40	39

Pin numbers 41 through 50 are differentially driven with the odd-numbered pins being the positive signal.

DESCRIPTION	-SIGNAL	+SIGNAL
RESERVED	42	41
WRTDTA	44	43
RDDTA	46	45
RESERVED	48	47
RDCLK	50	49

5.5. Modes of Operation

There are sixteen possible modes of operation for the ODI. There are eight modes for data out in MODE OUT and eight modes in MODE IN for data in. Data on the CUB(7-0) is output to the drive when the desired mode is set on MS(2-0) and MODE OUT ENABLE(MOE) is strobed. Data on the CUB(7-0) is input to the controller when the desired mode is set on MS(2-0) and MODE IN ENABLE(MIE) is asserted.

Table 5-2: Summary of ODI Modes

MOE	MIE	MS(2)	MS(1)	MS(0)	ODI MODE OUT
1	0	0	0	0	Unit Select
1	0	0	0	1	Track Select (MSB)
1	0	0	1	0	Track Select (LSB)
1	0	0	1	1	RESERVED
1	0	1	0	0	Spin Select
1	0	1	0	1	RESERVED
1	0	1	1	0	Diagnostic Select
1	0	1	1	1	Control Select

MOE	MIE	MS(2)	MS(1)	MS(0)	ODI MODE IN
0	1	0	0	0	Unit Selected
0	1	0	0	1	Current Track (MSB)
0	1	0	1	0	Current Track (LSB)
0	1	0	1	1	Sector Address
0	1	1	0	0	Unit Status
0	1	1	0	1	Unit Sense
0	1	1	1	0	Diagnostic Status
0	1	1	1	1	RESERVED

5.6. Theory of Operation

5.6.1. Sending Commands

To send a command to the drive, the desired mode is enabled on MS(2-0), the desired data enabled on CUB(7-0), and MOE is strobed. When MOE is strobed, the data on MS(2-0) and CUB(7-0) are latched in the drive and the command is received.

5.6.2. Receiving Status

To receive status from the drive, the desired mode is enabled on MS(2-0) and MIE is asserted. The status information is then enabled on CUB(7-0) by the drive. The status information is valid as long as MIE stays asserted.

5.6.3. Busy/Ready

The Drive Busy Bit in the drive status register indicates one of the two drive conditions:

- a. The drive is busy in response to a command from the controller.
- b. The drive is temporarily occupied performing an internal operation.

A Control Select command will be accepted by the drive for up to 50 microseconds after the Drive Busy Bit is set in the drive status register.

5.6.4. Spiral Track

The actual physical track on an optical disk is in the form of a continuous spiral from the center to the outer edge. However, the term "track" used here refers to the area covered in one revolution of the disk. Each track is preformatted to contain 25 sectors. In order for the beam to stay on a track, a micro-jump is required once per revolution. In preparation for this jump, the Drive Busy Bit is set after the drive reads the preformat address in Sector 22. The micro-jump occurs in Sector 23 and, if the drive is on the correct track in Sector 24, the Drive Ready Bit and the On Track Bit are set. This is the condition after spin up. If a SPIRAL ON command is sent, the drive does not micro-jump and continues to follow the spiral until the end of the disk is reached.

5.7. Functional Operation

The general functional operations performed by the drive are:

- a. Drive selection response
- b. Seek
- c. Write
- d. Read

5.7.1. Drive Selection Response

The selection operation establishes communication with one of eight possible drives on the ODI. The Unit Select mode is set on MS(2-0) and the bit-significant address of the drive desired is set on CUB(7-0). MOE is then strobed. Drive selection can be verified by using the Unit Selected mode.

5.7.2. Seek

The seek operation moves the beam to a specified track location. The track address is sent to the drive using two Track Select Commands. The Track Select (MSB) mode is set on MS(2-0) and high order address byte is set on CUB(7-0). MOE is the strobed. Then the Track Select (LSB) is set on MS(2-0) and the low-order address byte is set on CUB(7-0). The high-order address byte must be sent first. The Current Track MSB and Current Track LSB modes can be used to verify the track address.

5.7.3. Write

The Write operation transfers data to the drive. The track address should be verified prior to writing. The Sector Address mode is set on MS(2-0) and the sector address read. When the desired sector address minus one is read, the Control Select command, WRITE ON, is sent to the drive. Writing actually begins on the negative transition of SCTMRK. The drive continues to write one bit of data with each RDCLK pulse. The write operation is inhibited if any fault conditions are detected.

5.7.4. Read

The Read operation transfers data from the drive to the controller. The Sector Address mode is set on MS(2-0) and the sector address is read. When the desired sector address minus one is read, the next negative transition of SCTMRK indicates the beginning of valid read data.

SECTION VI

6. DISK AND FORMAT

6.1. General Description

A 12-inch diameter disk with a physical format based on the consumer video disk is used as the recording medium in the Optimem 1000 Optical Disk Drive. A hard shell cover protects the disk during operator handling, transport, and storage. Many of the techniques used in the manufacture of digital optical disk media are derived from work done initially for the video disk industry. These techniques take advantage of the high-volume manufacturing methods developed for the consumer video business and will result in low-cost disks when volume production is implemented.

The Optimem 1000 disk is pregrooved with tracking information. It is preformatted with the sector and track address information necessary for random access. This information is either embossed on the surface of the disk when the disk is injection-molded (plastic substrate disks), or it is formed in a contact polymerization process (glass substrate disks).

6.2. Plastic Substrate

The plastic substrate is based on injection-molded disks of polymethylmethacrylate (PMMA) which are 1.2 millimeters in thickness and have a nominal index of refraction of 1.485. Once the disks have been pregrooved (and preformatted), they are sent through various vacuum processes. These processes precisely deposit a thin film coating on the surface of the disks which is used to develop the sensitive recording layer of the disks. The disks are then assembled into an air sandwich configuration, with the sensitive layer on the inside of the sandwich for protection. Since the optical read or write beam must travel through 1.2 millimeters of optical quality plastic in order to reach the sensitive layer, the disk is relatively insensitive to first (outer) surface contamination. With lenses of the numerical aperture used in the Optimem 1000 (approximately .5), a 1 micrometer spot on the sensitive layer is more than 1 millimeter in diameter on the first surface of the disk.

Glass substrate disks are virtually identical to the plastic substrate disks except that the substrate material is chemically tempered glass, 1.18 millimeters thick with an index of refraction of 1.5. The difference in thickness compensates for the difference in the index of refraction to provide the same optical thickness. Instead of injection-molding, the pregroove is created by pressing a substrate coated with a PMMA resin against a master with a negative of the pregroove, and polymerizing the resin with ultraviolet light.

6.3. Disk and Substrate Specification Summary

Tables 6-1 and 6-2 outline the specifications for the disk and for glass and plastic substrates.

Table 6-1: Disk Specification Summary

DISK DIMENSION	VALUE
Thickness	4mm max.
Outer diameter	305mm
Inner diameter	35mm
Weight	550g max.

Table 6-2: Substrate Specification Summary

SPECIFICATION	GLASS	PLASTIC
Thickness	1.18mm	1.2mm
Index of refraction	1.505	1.485

6.4. Cartridge

6.4.1. General Description

The cartridge consists of two major assemblies: 1) a cover and 2) a carrier assembly which holds the disk itself. Side 1 of the cover contains a label with loading instructions and space to write cartridge identification information. Side 2 of the cover has a label with cartridge handling and storage instructions. The end label provides additional space for cartridge identification (when the cartridge is stored in a rack or mounted in the drive).

In the Optimem 1001, the carrier has a single sliding write protect tab. In the Optimem 1002, the carrier has two sliding write protect tabs. Both the cover and the carrier labels carry the same serial number.

6.4.2. Cartridge Specification Summary

Table 6-3 shows the specifications for the Optimem single-sided and double-sided cartridges. Figure 6-1 shows the physical dimensions of the cartridge.

Table 6-3: Cartridge Specification Summary

EQUIPMENT	SPECIFICATION
MODEL	
OPTIMEM 1001	One recording surface per cartridge
OPTIMEM 1002	Two recording surfaces per cartridge
CARTRIDGE	
Size	
Length	417.5mm (16.44 inches)
Width	336mm (13.23 inches)
Height	16mm (0.63 inches)
Weight	1.7 kg (3.75 lbs) max.
Environment	
Operating	
Temperature	10°C to 49°C (50°F to 120°F)
Humidity	10% to 90% RH
Storage	
Temperature	-40°C to 60°C (-40°F to 140°F)
Humidity	10% to 95% RH, noncondensing
Shipping	
Temperature	-40°C to 60°C (-40°F to 140°F)
Humidity	10% to 95% RH, noncondensing
Operating life	10 years

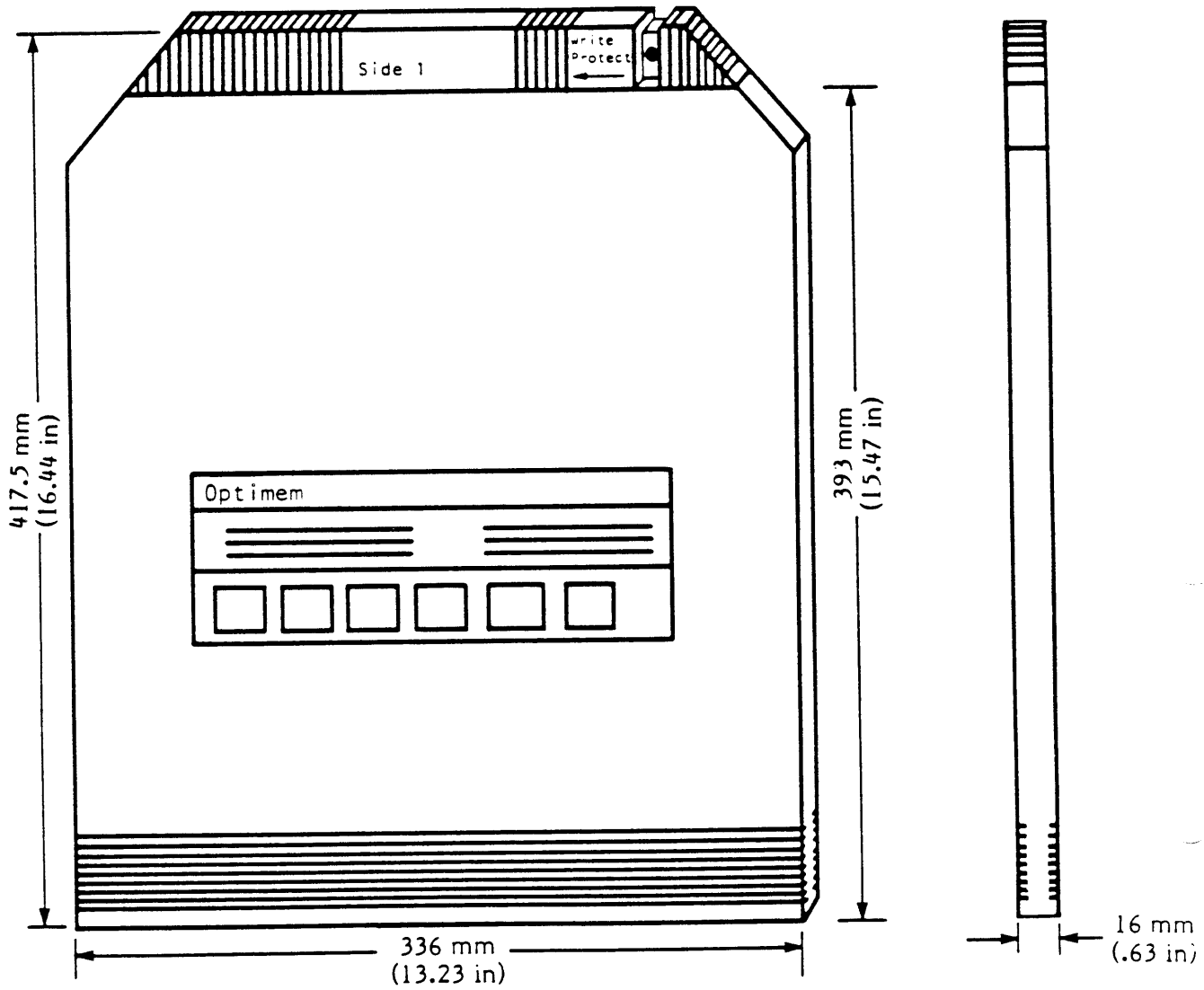

Fig. 6-1: Cartridge Dimensions

SECTION VII

7. MAINTENANCE

7.1. Warning

This product conforms to the applicable requirements of 21 CFR subchapter J at date of manufacture. In compliance with this regulation, portions of this drive may be serviced only by authorized service technicians. These restricted portions are indicated by the warning below.

DANGER

INVISIBLE LASER RADIATION WHEN OPEN.
AVOID DIRECT EXPOSURE TO BEAM.

THIS PRODUCT CONFORMS TO THE APPLICABLE
REQUIREMENTS OF 21 CFR SUBCHAPTER J AT
DATE OF MANUFACTURE.

7.2. Diagnostics

The Optimem 1000 Optical Disk Drive is capable of performing self-diagnostics on power up and isolating faults to the major assembly level. Three levels of fault diagnosis are available for analysis.

The first level of diagnostics is status. A red Fault-Status LED is located on the front panel of the drive. This LED will be lit when any of the fault status conditions occur. Write operations are inhibited during this time. The Error Status Register contains further information regarding the fault that occurred.

The second level of diagnostics is a pass/fail program which isolates failures to a major functional area.

The third level of diagnostics determines which components have actually failed.

7.3. PC Board Replacement

The boards contained in the card cage of the Optimem 1000 Optical Disk Drive are replaceable by noncertified personnel (see Figure 7-1 for the card cage location). All other board replacements throughout the drive require a certified technician.

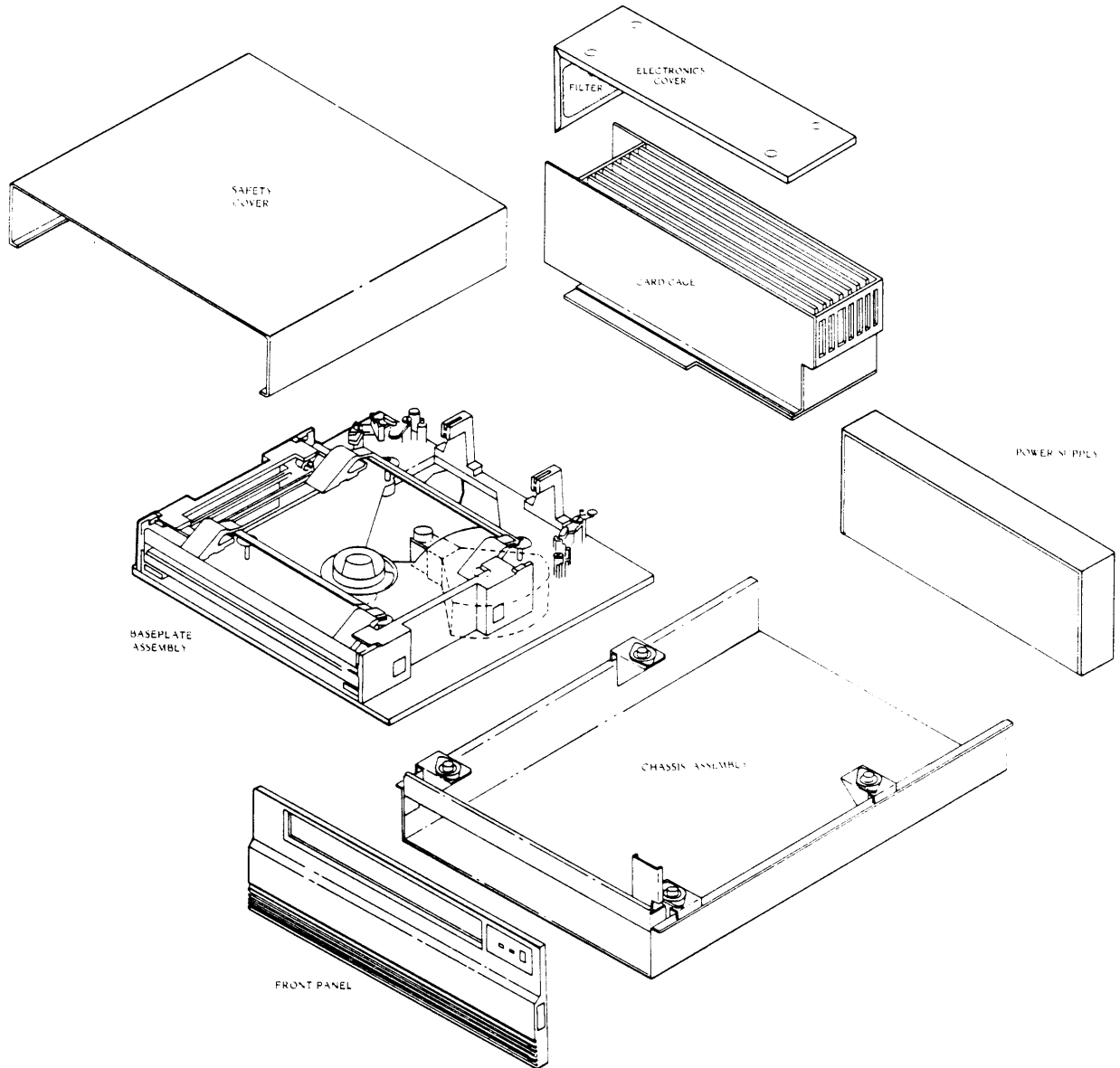

Fig. 7-1: Exploded View of Drive Components

WARNING: 1. The safety cover should be removed by an authorized service technician only. 2. Touching the lens may damage the lens suspension. Attempting to clean the lens will void the warranty.

7.3.1. PC Board Access

The card cage has slots for seven boards and an integral cooling fan. The card cage cover has an air filter attached to one side. Access to the boards is obtained by removing the four screws holding the card cage cover in place. Then facing the front of the drive, the cover is lifted from the right side. The air filter should be checked for integrity and cleaned or replaced if needed.

The card cage cover must be installed while operating the drive. This maintains the air flow pattern and ensures adequate cooling of the boards.

7.3.2. Board Location and Description

Refer to Figure 7-2 for board locations.

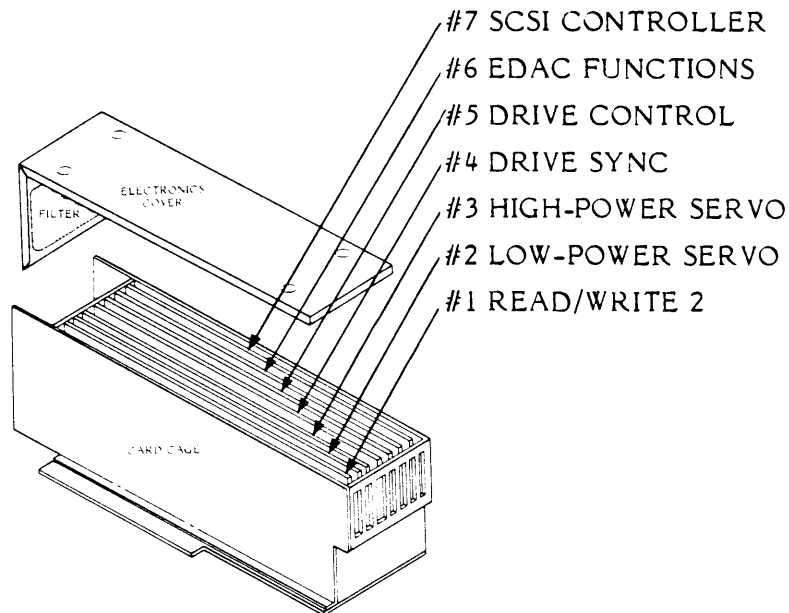

Fig. 7-2: PC Board Locations

The Read/Write 2 Board generates the position error signals for correct focus and tracking and supplies the data signals to the Drive Sync Board in the NRZ data form. It also contains the read-level threshold, sample and hold circuit, automatic gain control circuit and DC restoration circuit.

The Low-Power Servo Board contains the servo circuitry and driving stages for the focus and tracking actuators in the optics module.

The High-Power Servo Board contains the circuitry controlling the Coarse Actuator and the phase locked loop servo for spindle speed control.

The Drive Sync Board provides the master clock circuitry for timing the flag, block, and sector regions of the format. Sample and timing pulses are generated for use by the analog circuits and analog servos based on the preformatted information.

The Drive Control Board contains an eight-bit microprocessor to manage the basic drive functions. Communicating through the ODI with the Optimem 1000 SCSI Controller, it controls the enabling and disabling of all other boards, the positioning of the read/write head, the spindle speed, and spin up/spin down of the medium. In addition, all the monitoring functions and diagnostic functions are handled by the Drive Logical Control Board.

7.3.3. PC Board Part Numbers

The boards, in order from front to rear of the drive are:

1.	Read/Write 2 Board	P/N	D01-081394-XXX
2.	Low-Power Servo Board	P/N	D01-081396-XXX
3.	High-Power Servo Board	P/N	D01-081395-XXX
4.	Drive Sync Board	P/N	D01-081397-XXX
5.	Drive Control Board	P/N	D01-081398-XXX
6.	EDAC Functions Board	P/N	D01-081403-XXX
7.	SCSI Controller Board	P/N	D01-081404-XXX

CAUTION

Do not remove the bracket mounted diagonally across the mother board. It serves as a card key. Any change in the order of the boards will result in damage.

7.4. Power Supply

7.4.1. Features

The power supply used in the Optimem 1000 Optical Disk Drive is a 170-watt switching supply with several special features. These features are:

- power failure detection on the five-volt supply
- over-voltage protection
- overload and short circuit protection
- remote shutdown
- over-temperature protection
- EMI filtering

7.4.2. Installation

Refer to Figures 7-3, 7-4, and Table 7-1 for assistance on the following procedures:

The power supply is mounted to the card cage by four screws, two on each side of the card cage (see Figure 7-3).

A 12-position connector plugs into the motherboard (see Table 7-1 for pin-outs).

If required, replace the internal power supply fuse (Figure 7-4).

To install the power supply, proceed as follows:

1. Plug the connector into the motherboard (Figure 7-3). The connector is keyed so that it can be inserted in only one position.
2. Hold the power supply close to the card cage, loop the cable-harness and place it in the notch.
3. Place the power supply in position on the card cage so that the mounting holes line up.
4. Check the cable harness to ensure that there are no pinched wires.
5. Install the four mounting screws (Figure 7-3).
6. Check the rating on the fuse in the rear of the power supply for the voltage selected (Figure 7-3).

- 115 volt uses a 3.0 ampere slo-blow fuse.
- 230 volt uses a 1.5 ampere slo-blow fuse.

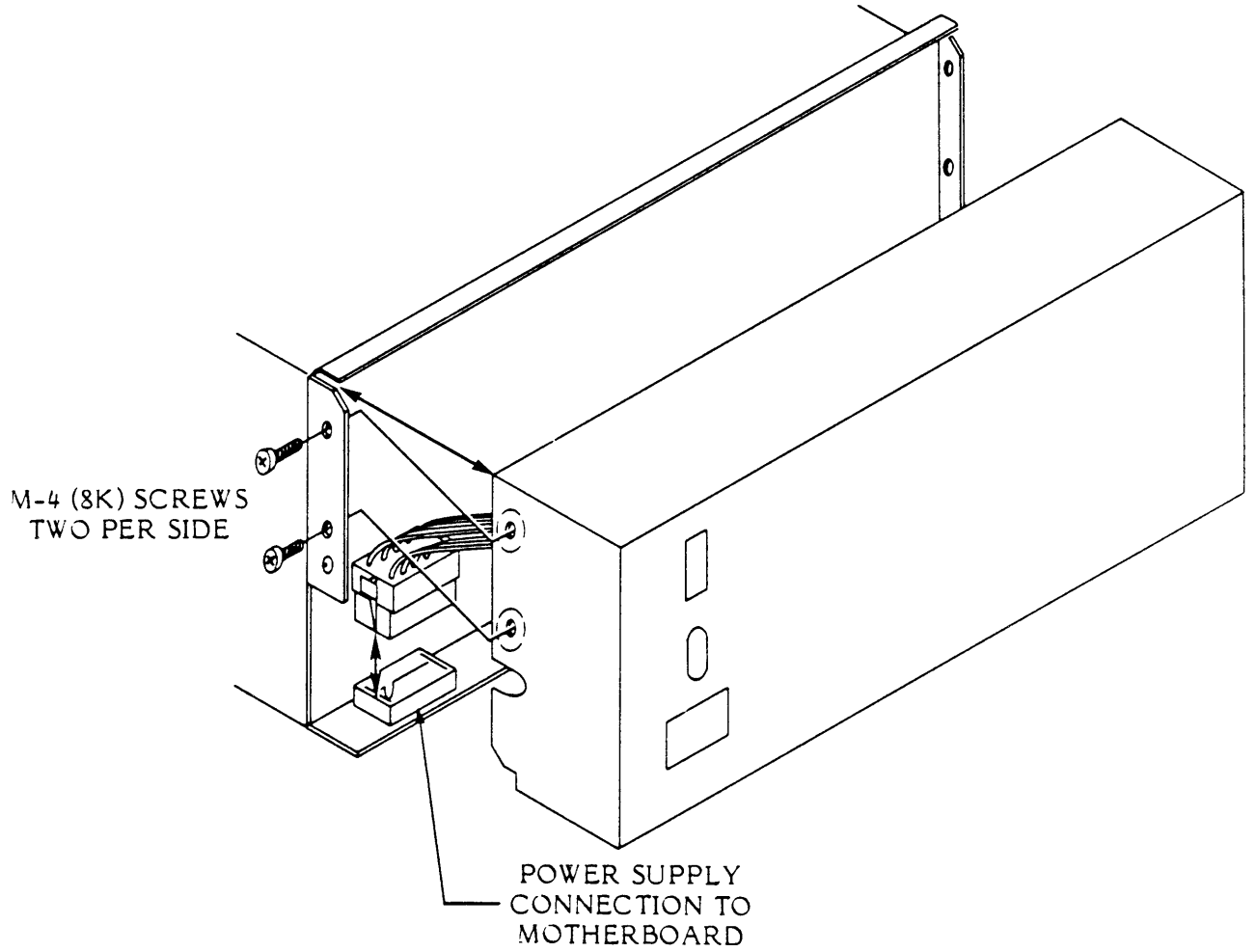

Fig. 7-3: Power Supply Attachment

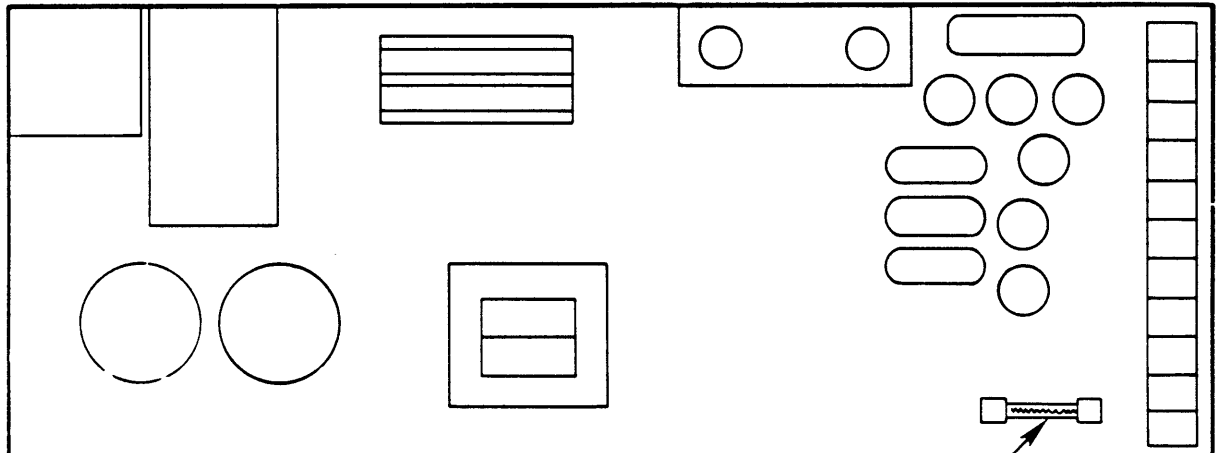

Fig. 7-4: Power Supply Internal Fuse

INTERNAL POWER
SUPPLY FUSE

3.5 amperes 115 v

2.0 amperes 230 v

7.4.3. Power Supply Removal

To remove the power supply:

- a. Remove the four mounting screws (see Figure 7-3).
- b. Slide the power supply out and disconnect the connector from the mother-board.

Table 7-1: Power Connector Pin-outs

PIN	DESCRIPTION
1	-15 Vdc +/- 10% at 4 amperes
2	+15 Vdc +/- 10% at 4 amperes
3	+5 Vdc
4	+5 Vdc +/- 5% at 15 amperes
5	5 V sense to power supply
6	Ground sense to power supply
7	PSOT-L power supply over temperature
8	AC FAIL low voltage indicator
9	Digital Ground
0	Digital Ground
1	Analog Ground
2	Analog Ground

7.5. Preventative Maintenance Philosophy

The Optimem 1000 is designed to provide the user with thousands of power-on hours of trouble free operation. There are no parts that require periodic maintenance during the life of this product. Motor and actuator bearings are permanently lubricated and sealed. Conservative design margins and widespread use of feedback techniques in analog circuits allow for component tolerance drift without any need for periodic circuit adjustments. The optics module is sealed after assembly in a dust free environment. The objective lens should not require cleaning under normal circumstances. Under no circumstances should an attempt to clean the objective lens be made. The lens suspension is very delicate and any action to clean the lens may result in irreparable damage to the two-axis assembly of the lens.

A. Power Supply Reconfiguration 115V to 230V

Conversion of the Power Supply from 115V to 230V requires:

1. the removal of the Power Supply Assembly from the drive. See section 7.4.3 Power Supply Removal.
2. changing the voltage jumper on the Power Supply circuit board from the 115V to the 230V location.
 - a. Type A - soldered jumper

the Power Supply circuit board must be removed from the assembly

the jumper must be unsoldered
 - b. Type B - unsoldered jumper
3. replacing the internal fuse in the fuse clips on the Power Supply circuit board.

MTH 5.0 ampere for 115V ac
AGC 2.5 ampere for 230V ac
4. replacing the main fuse in the rear panel fuseholder.

3.0 ampere for 115V
1.5 ampere for 230V
5. replacing the line cord or cutting off the plug and installing a proper plug.

Note A drive can be ordered from the factory equipped with a 230V Power Supply.

B. SCSI Controller Reconfiguration

B.1. SCSI ID

An SCSI Device is selected by the assertion of the DATA BUS bit, DB(7) through DB(0), which corresponds to its SCSI ID. The SCSI Device asserts its assigned data bit (SCSI ID) but leaves the other DATA BUS bits in the released state.

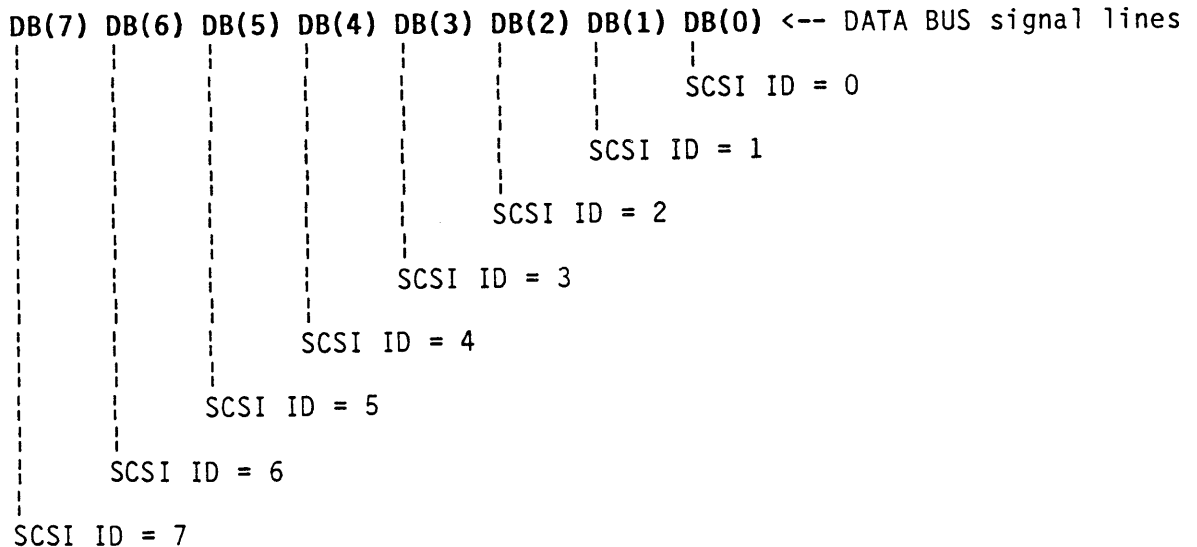
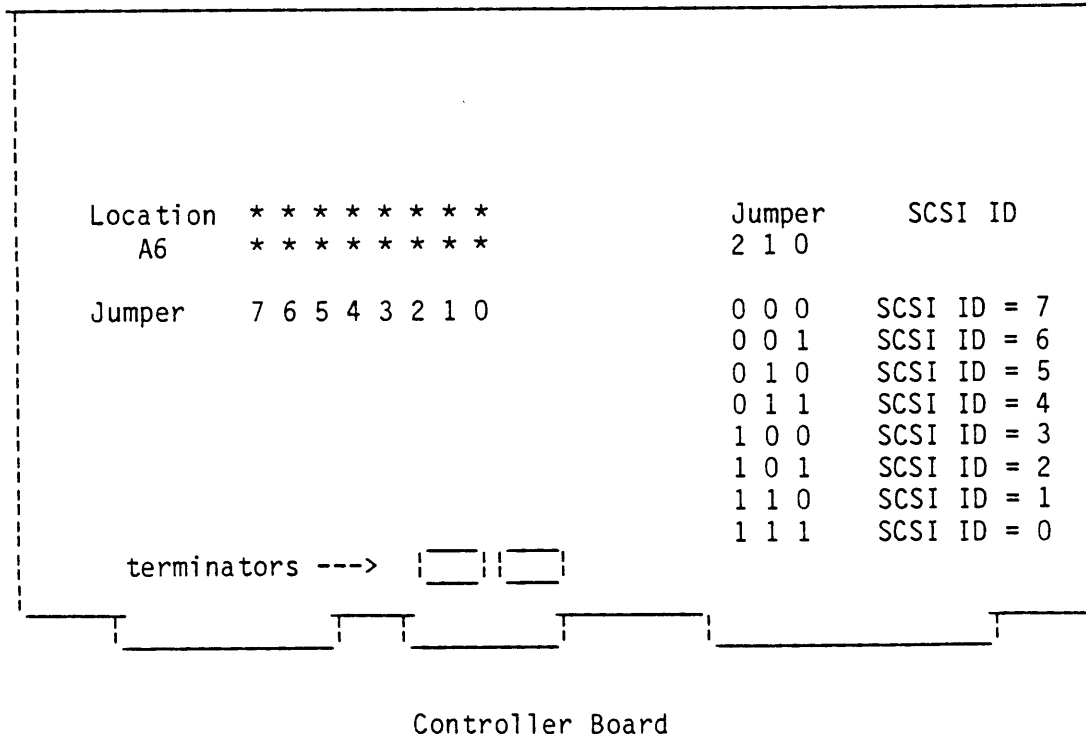

Fig. B-1: SCSI ID Bit

The SCSI ID of the Optimem 1000 Controller is assigned by the use of eight jumpers on the Controller Board. Three of these jumpers are used to set the ID which is presently shipped with an address of zero. See the figure below.



0 means jumper removed
 1 means jumper inserted

Fig. B-2: SCSI ID JUMPERS

B.2 Termination

Termination is required on each end of the SCSI Bus to assure proper signal levels. If multiple SCSI devices are used then termination must be removed from all SCSI devices except those at each end of the SCSI Bus. The terminators on the SCSI Controller Board are located at H2 and J2.

B.3. Interleave Selection

The controller has a selectable interleave of one (sectors read contiguously), or three (every third sector is read). The interleave is set by jumper 7 at location A6 on the SCSI Controller Board. If the jumper is removed the interleave is one; if the jumper is inserted the interleave is three.

C. LUN Reconfiguration

C.1. LUN Selection

Slave drives connected through the ODI are selected by Logical Unit Number (LUN). The LUN of each drive is assigned by a jumper on the Drive Control Board as shown below. All drives are assigned a LUN of zero at the factory. If multiple slave drives are used, the LUNs must be changed.

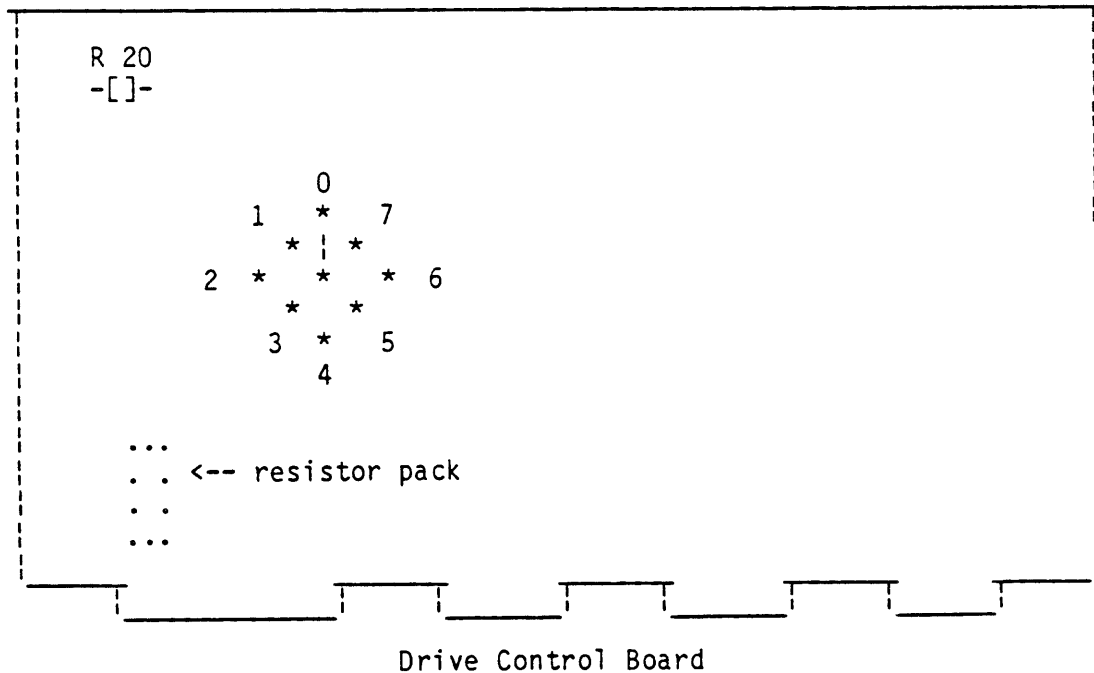

termination resistor (R 20) is located at B5
 termination resistor pack is located at D7

Fig. C-1: LUN Assignment

C.2. Termination

Termination is required on each end of the ODI Bus to assure proper signal levels. One termination end consists of a resistor pack which resides permanently on the SCSI Controller Board at D1. The other termination which consists of a termination resistor pack and a terminator resistor are located on the Drive Control Board as shown above.

If multiple slave drives are used they should be connected in daisy-chain fashion with a 50 pin cable to each ODI connector. Termination should be removed from all drives except for the drive at the end of the bus. This includes both terminator resistor and terminator pack on the Drive Control Board.

END OF DOCUMENT
