

SA-H105Q  
5.25" LSI-11 System Chassis  
with Quad/Dual Backplane  
Manual

SA-H105Q  
5.25" LSI-11 System Chassis  
with Quad/Dual Backplane  
Manual

Copyright © March, 1983

Sigma Information Systems



CONTENTS

SECTION 1 - GENERAL INFORMATION

1.1	INTRODUCTION	1
1.2	GENERAL DESCRIPTION	2
1.3	CHASSIS	2
1.4	FRONT CONSOLE	3
1.5	BACKPLANE	4
1.6	POWER SUPPLY	4
1.7	SPECIFICATIONS	5

SECTION 2 - INSTALLATION

2.1	UNPACKING AND INSPECTION	7
2.2	DRIVE INSTALLATION	8
2.2.1	5 1/4" Winchester Drive Installation	8
2.2.2	8" Slimline Floppy Drive Installation	10
2.3	MODULE INSTALLATION	11
2.3.1	Device Priorities	11
2.3.2	Backplane Priorities	12
2.3.3	Jumpers/Terminating Resistors	12
2.3.4	Module Alignment	15
2.4	POWER SUPPLY	16
2.4.1	DC Backplane Power Connections	16
2.4.2	Front Panel Connections	16
2.5	CHASSIS INSTALLATION	17

SECTION 3 - VOLTAGE ADJUSTMENTS

3.1	GENERAL INFORMATION	19
3.2	VOLTAGE ADJUSTMENTS	19
3.2.1	5VDC Adjustment	20
3.2.2	Power Fail Detect Adjustment	21
3.3	ASSEMBLY/DISASSEMBLY	23
3.3.1	Removal of Chassis Assembly from Rack	23
3.3.2	Display Bracket Removal	23
3.3.3	Power Supply Removal	23
3.3.4	Backplane Removal	23

FIGURES

1-1	SA-H105Q SYSTEM CONFIGURATION	2
1-2	FRONT CONSOLE	3
2-1	5 1/4" WINCHESTER DRIVE INSTALLATION	8
2-2	WINCHESTER DRIVE POWER CONNECTOR	9
2-3	8" SLIMLINE FLOPPY DRIVE INSTALLATION	10
2-4	FLOPPY DRIVE POWER CONNECTORS	10
2-5	BACKPLANE DEVICE PRIORITY ASSIGNMENTS	12
2-6	BACKPLANE JUMPERS AND TERMINATING RESISTORS	13
2-7	MODULE ALPHANUMERIC SLOT IDENTIFIERS	15
2-8	J9 AND J10 CONNECTOR ILLUSTRATION	16
3-1	DC POWER ADJUSTMENT LOCATIONS	20
3-2	POWER FAIL DETECT TIMING	22

TABLES

2-1	TERMINATION RESISTOR CONNECTIONS	14
2-2	J9 AND J10 FRONT PANEL CONNECTION	16
2-3	DC VOLTAGE MEASUREMENT	17

## SECTION 1 - GENERAL INFORMATION

---

### 1.1 INTRODUCTION

This manual provides general information, drive and module installation, and power supply adjustments for the SA-H105Q system chassis manufactured by Sigma Information Systems, Anaheim, California. The material is arranged into the following sections.

Section 1 - GENERAL INFORMATION. This section provides a general description of the 5.25" chassis. Specifications are included.

Section 2 - INSTALLATION. This section describes the procedures for mounting the chassis in a standard rack, installing peripheral equipment into the chassis, and inserting modules into the backplane.

Section 3 - POWER SUPPLY ADJUSTMENTS. This section provides the adjustments, troubleshooting, and assembly/disassembly necessary for maintaining the SA-H105Q.

APPENDICES. The appendices consist of system schematic and DC power supply schematics. Q bus pin assignments are also provided.

## 1.2 GENERAL DESCRIPTION

The SA-H105Q is a small system chassis designed to provide full system capability in a compact space. The chassis includes a mixed 4-row quad plus 4-row dual wide backplane with twelve dual Q bus\* slots. The chassis provides mounting space and power for a 5 1/4" winchester disk drive and an 8" slimline floppy disk drive.

## 1.3 CHASSIS

The SA-H105Q system chassis contains the 12-slot quad/dual-wide backplane, the power supply, two cooling fans and the front operator console. Refer to Figure 1-1. Chassis slides for rackmount installation are included with rackmount versions, and a dress cover is included with tabletop versions. Access to the installed modules and drives is from the top. Cooling air inlets at the sides and exits at the rear of the chassis.

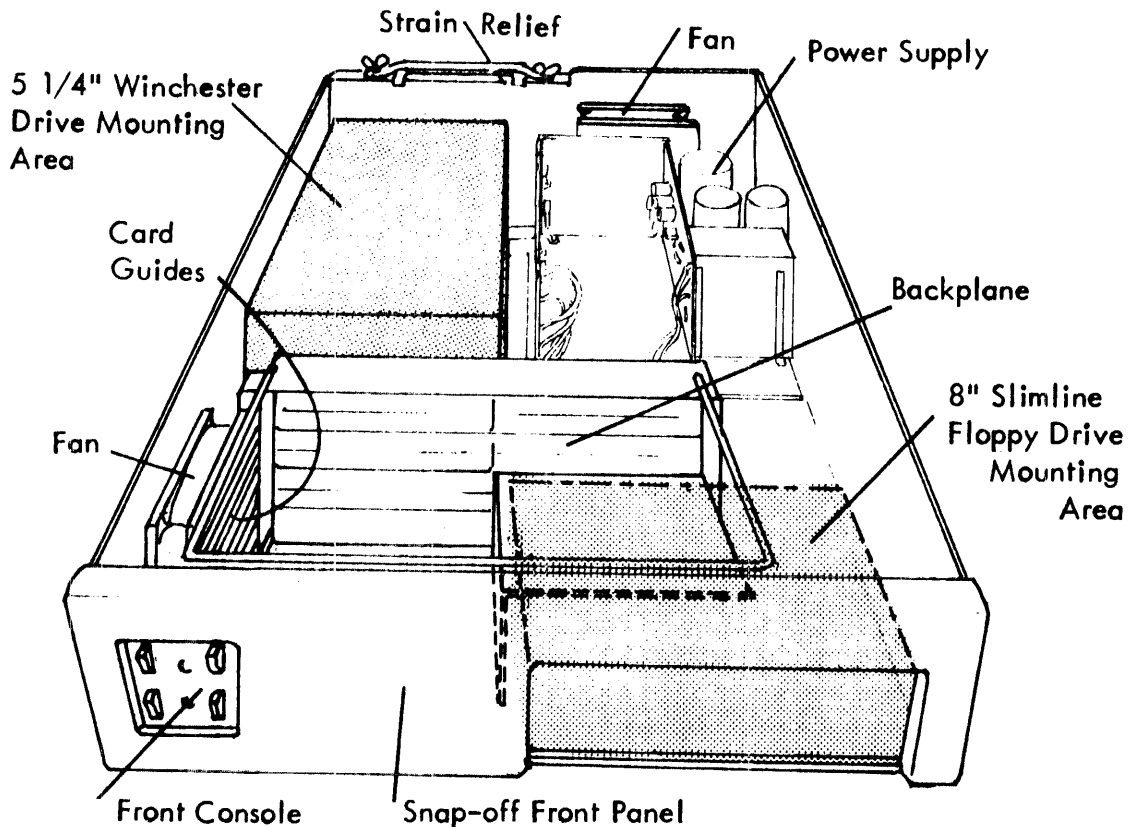

FIGURE 1-1: SA-H105Q SYSTEM CONFIGURATION

\*Registered trademark of Digital Equipment Corporation.

#### 1.4 FRONT CONSOLE

The operator console assembly is mounted on the front of the chassis and consists of four switches and two LED indicators as shown in Figure 1-2 below.

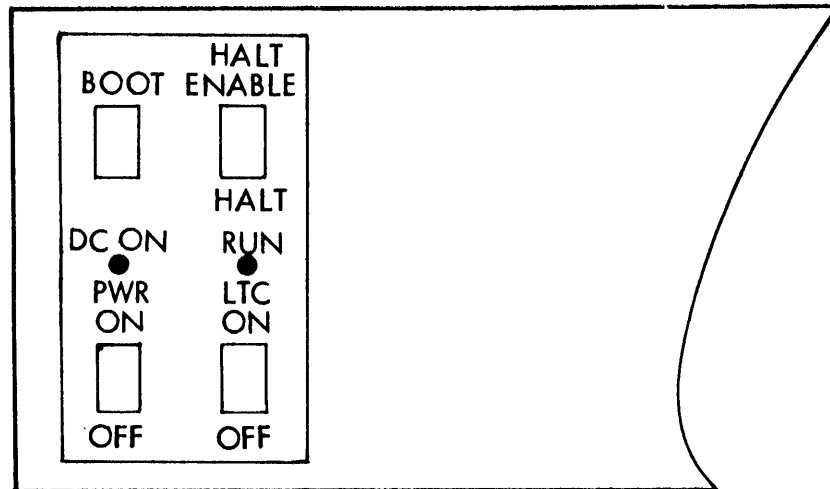

FIGURE 1-2: FRONT CONSOLE

ON-OFF SWITCH. The power supply includes a remote ON/OFF solid state relay. When the ON/OFF switch is in the ON position, the relay is enabled. AC is supplied to the power supply and fans and DC to the backplane is enabled.

LTC ENABLE SWITCH. When in the ON (up) position, a line frequency square wave is impressed upon the B EVENT line (BR1), causing the LSI-11 CPU to be interrupted at line frequency (50 or 60Hz).

BOOT SWITCH. This is a momentary two-position switch. When depressed, the BDCOK line (BA1) is momentarily asserted, causing the CPU to address the location of the bootstrap PROM (173000). Depending on the bootstrap option selected, the system will either boot to a specified device or enter a bootstrap monitor.

HALT/ENABLE SWITCH. When in the HALT position, the B HALT line (AP1) is asserted, causing the CPU to go into ODT mode. When in the ENABLE position, a high on the B HALT line is generated, allowing programs to be run.

DC ON LED. When on, this LED indicates 5V is applied to the front panel.

RUN LED. When on, this LED indicates that the SRUN line is asserted and a program is being executed from main memory. When off, either the CPU is in ODT or it is in a Programmed Wait state.



## 1.5 BACKPLANE

The dual/quad-wide backplane supplied with the system chassis provides direct plug-in installation for Q bus compatible modules. The backplane contains twelve dual Q bus slots. The PCBA overlays the pin side of the backplane and is recessed to permit wire wrapping if user modification is required.

The backplane provides optional 22-bit addressing for use with LSI-11/23 modules. A card frame assembly supports installed modules and provides positive insertion alignment.

## 1.6 POWER SUPPLY

The power supply is designed for 50/60Hz operation and can be converted between 115VAC and 230VAC. The regulated power outputs are 5VDC at 25A, 12VDC at 3.8A, 24VDC at 2.6A and -5VDC at 0.5A. The 5VDC output voltage is adjustable.

AC input power is applied via the power cord, through an IEC compatible connector and fuse to the power supply voltage regulator PCBA. The input power is filtered at the transformer inputs by 0.01uf capacitors. Transient voltage suppressors protect the power supply from transient voltage spikes. The AC input also provides power to two fans located in the chassis. Power for these fans is derived from the input windings on the power transformer, allowing the use of 115VAC fans for both 115VAC and 230VAC operation.

Power fail detect circuitry provides BPOKH and BDCOKH signals in the proper timing sequence. The power supply also provides the LTC signal which is connected to the BEVENT line (BR1) and controlled by the front panel switch, LTC. This signal is used by the Q bus as timing for a line time clock.

Two AC convenience outlets at the rear of the power supply are fused, but unswitched. These outlets provide output line voltage for terminals, printers, etc. Maximum current available for both outlets is 3A.

## 1.7 SPECIFICATIONS

Capacity: 4-row quad-wide and 4-row dual-wide backplane with twelve dual Q bus slots. Power and mounting space for 5 1/4" winchester drive and 8" slimline floppy drive.

Installation: Rackmount version mounts in standard 19" RETMA rack and occupies 5.25" of vertical rack space. Rackmount versions are 24" deep with 0.5" recommended for rear cable egress.

Tabletop version occupies 19" wide by 24" deep desk area and is 5.25" high.

### Power

Input: 115VAC or 230VAC + 10%, 50/60Hz  
480VA max - not including AC power to convenience outlets (4A at 115VAC or 2A at 230VAC)

Output:           5VDC   12VDC           24VDC           -5VDC  
          18.0A   3.8A       2.6A (5A peak)   0.5A

Cooling: Forced air, side intake with rear exhaust. Separate fans for power and installed modules.

Accessibility: Access to backplane modules and installed peripherals is from the front of the chassis.

Cable Egress: At the rear of the chassis with strain reliefs for cables.

Environment:	Temperature	Humidity	Altitude
Operating	0°C to 50°C	0 to 95%	0 to 10,000ft
Storage	-45°C to 85°C	0 to 95%	0 to 30,000ft

March 11, 1983  
Page 6

## SECTION 2 - INSTALLATION

---

### 2.1 UNPACKING AND INSPECTION

Unpack the 5.25" system chassis and visually inspect it for damage that might have occurred during shipment. Retain the shipping carton in case reshipment is necessary. Remove the chassis covers and inspect the backplane, power supply, etc., for component damage. If any damage has occurred, notify Sigma Information Systems immediately.

Each shipping container should include the following:

An SA-H105Q system chassis assembly with backplane, power supply, and front bezel.

An SA-H105Q system chassis manual and logic diagrams for power supply modules.

An AC power cord.

A hardware kit containing required hardware for rack-mounting the chassis (for rackmount versions only), and optional hardware for the specified drives.

An optional winchester drive bracket for mounting the Xebec S1410 formatter to the 5 1/4" drive for use with the Sigma SDC-RLV12 winchester controllers

## 2.2 DRIVE INSTALLATIONS

The SA-H105Q provides mounting space and power for a 5 1/4" winchester drive and an 8" slimline floppy disk drive. Access to the floppy drive is front the front panel. The SA-H105Q can accommodate different types of peripherals and this section is meant to serve as a general guide for drive installation.

### 2.2.1 5 1/4" Winchester Drive Installation

The 5 1/4" winchester drive mounts at the left-rear of the chassis. Using Figure 2-1 as a guide, install the drive.

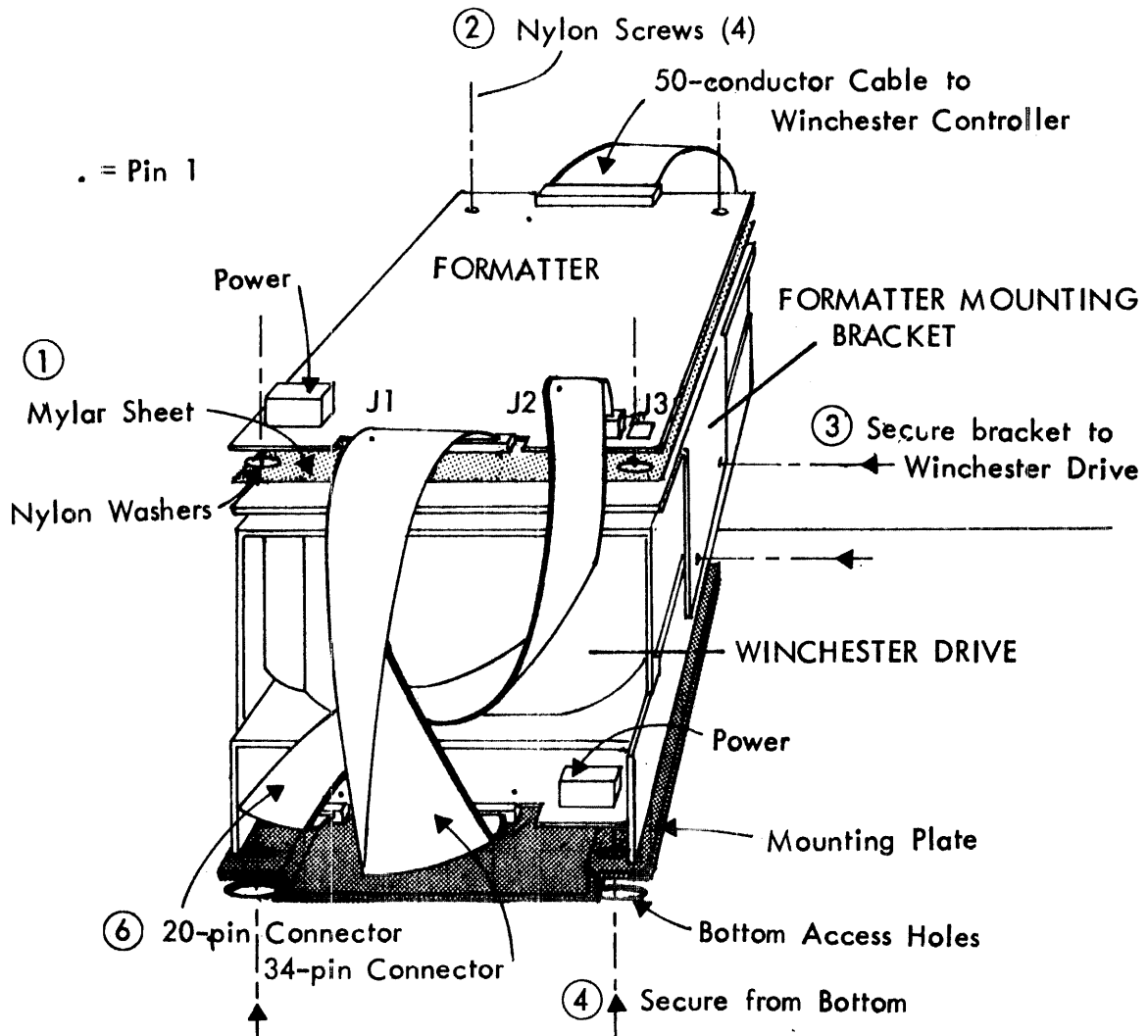
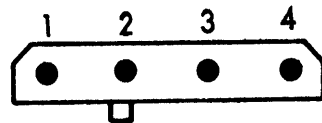

FIGURE 2-1: 5 1/4" WINCHESTER DRIVE INSTALLATION

1. Place the mylar sheet over formatter mounting bracket. Insert nylon washers between module and mounting bracket.
2. Secure formatter to bracket using nylon screws.
3. Place formatter assembly over winchester drive and secure the assembly from the drive sides using 6-32 x 3/8 screws.
4. Place winchester drive assembly over left-rear mounting rails and secure from the bottom of the chassis using 8-32 x 3/8" screws.
5. Verify the voltages in the drive power cable are correct per drive manufacturer's specifications. The standard configuration is shown in Figure 2-2 below.



AC CONNECTOR  
 AMP 1-480424-0  
 PIN 60619-11

Pin 1 = 12VDC  
 Pin 2 = 12VDC RETURN  
 Pin 3 = 5VDC RETURN  
 Pin 4 = 5V

FIGURE 2-2: WINCHESTER DRIVE POWER CONNECTOR

5. Connect winchester/formatter cables as shown in Figure 2-1. Pay special attention that pin 1 connections are correct.

### 2.2.2 8" Slimline Floppy Disk Drive Installation

Using Figure 2-3 as a guide, install the 8" slimline floppy drive.

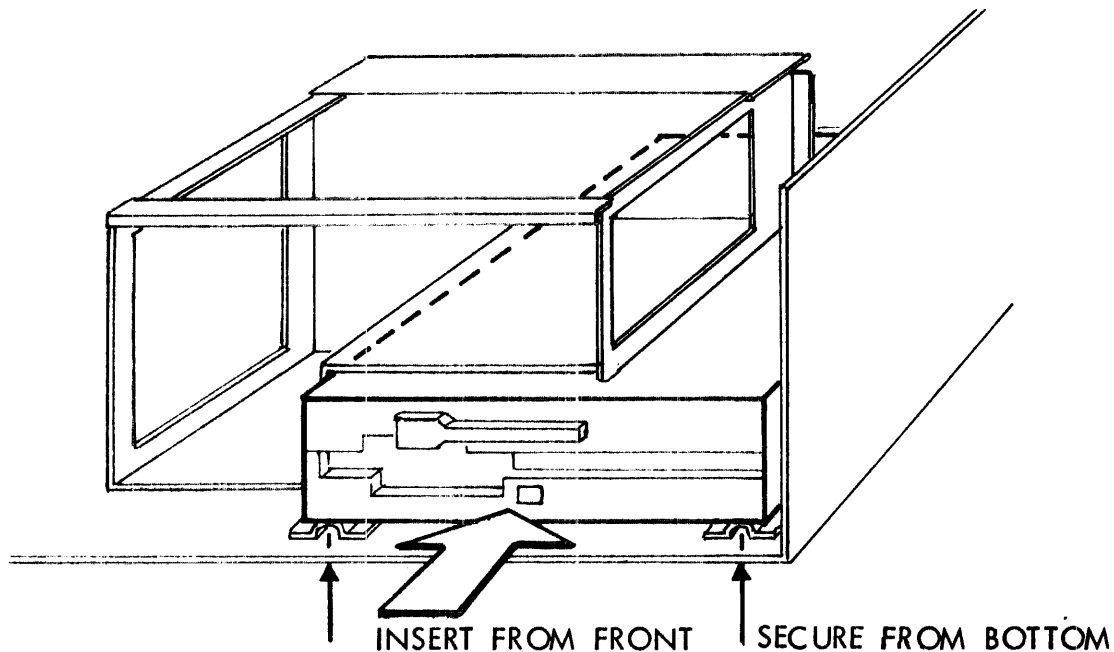
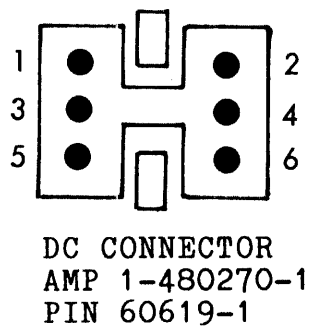

FIGURE 2-3: 8" SLIMLINE FLOPPY DRIVE INSTALLATION

1. From the front of the chassis, insert the floppy drive over the floppy drive mounting rails as shown.
2. Secure drive to the mounting rails from the bottom access holes using 8 32 x 3/8" screws.
3. Verify voltages in the drive power cable are correct per drive manufacturer's specifications. The standard configuration is shown in Figure 2-4.



Pin 1 = 24VDC  
Pin 2 = 24VDC RETURN  
Pin 3 = GND  
Pin 4 = N/C CABLE=10V  
Pin 5 = 5VDC  
Pin 6 = ~~N/C~~ GND

FIGURE 2-4: FLOPPY DRIVE POWER CONNECTORS

## 2.3 MODULE INSTALLATION

Modules plug directly into the backplane with priorities determined by the distance from the CPU. When more than one device requests interrupt service, the device that is closest to the CPU will receive the interrupt grant. When assigning device priorities, several factors should be considered.

### 2.3.1 Device Priorities

There are two separate priority channels in the Q bus backplane. One channel is for interrupting devices and the other is for DMA devices. A DMA device uses both priority channels whereas a programmed I/O (PIO) device uses only the interrupt priority channel.

When installing modules, consider the following:

1. All priorities are serial, i.e., the module closest to the processor has the highest priority.
2. When used with the LSI-11/23 CPU, interrupting devices can be assigned to one of three different priority levels. However, if two devices are assigned the same level, the device nearest the processor receives high priority.
3. DMA devices such as rotating disk memory or real-time data acquisition devices must be serviced by the processor within their latency. For example, the disk memory rotates past the head at a certain rate, causing data to be read to memory or written from memory at the same data rate. If the CPU does not allow the disk memory to obtain the bus in order to complete a transfer before the disk rotates to position to start the next transfer, the latency of the disk has been exceeded and an error will occur. The system designer must place DMA devices on the bus such that the devices with the shortest latency have the highest priority.
4. In most systems, both DMA and PIO devices must exist in the same system. The normal rule is that DMA devices have highest priority and PIO devices have lower priority. Since both DMA and Interrupt Acknowledge lines are serial, each slot between a DMA or PIO device must be occupied in order for the signals to be passed through.



### 2.3.2 Backplane Priorities

The 12-slot quad/dual-wide Q bus backplane assembly is designed to be compatible with the LSI-11, LSI-11/2 and LSI-11/23.

Figure 2-5 defines the device priorities for the backplane.

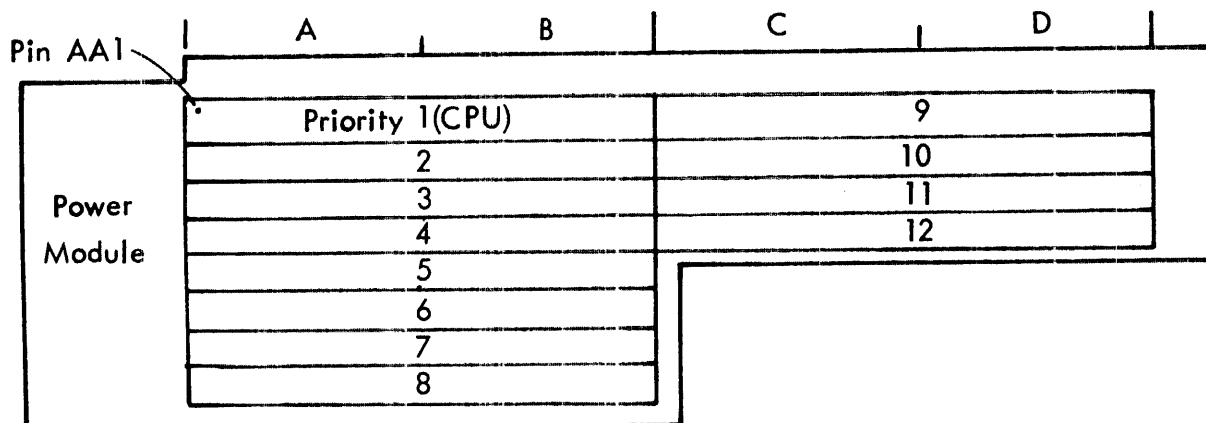

FIGURE 2-5: BACKPLANE DEVICE PRIORITY ASSIGNMENTS

### 2.3.3 Backplane Jumpers/Terminating Resistors

The SA-H105Q backplane provides optional 22-bit addressing for use with new LSI-11/23 modules, memories and DMA devices designed to accommodate 22-bit addressing. The address bits are assigned as follows:

BADL18L	BC1, DC1
BDAL19L	BD1, DD1
BDAL20L	BE1, DE1
BDAL21L	BF1, DF1

Since the quad LSI-11 and the dual LSI-11/2 both use these signal lines internally, the extra address bits should not be connected when the system is not being used as a 22-bit system. The backplane provides four option jumpers on row B for interconnection of the 22-bit addresses. The backplane also includes five terminating resistor modules. Refer to Figure 2-6.

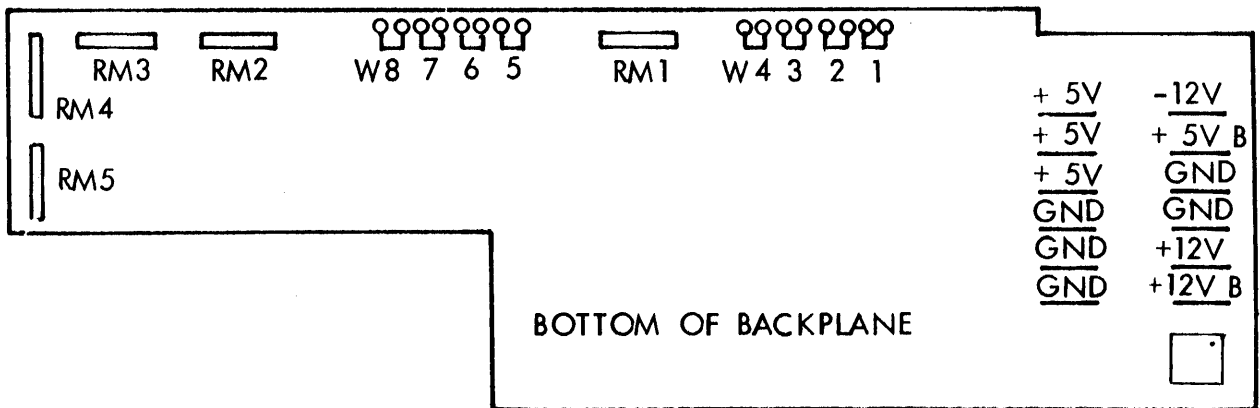

FIGURE 2-6: BACKPLANE JUMPERS AND TERMINATING RESISTORS

When the system is to be used with 22-bit addressing, install W1, W2, W3 and W4. When used with the LSI-11/2, remove W1 through W4. When used with quad-wide LSI-11, also remove W5, W6, W7 and W8.

Resistor modules RM1 through RM5 are normally installed in the backplane to provide full termination of all Q bus lines. If the system is already using a bootstrap/terminator, and no termination is required, remove resistor modules RM1 through RM5. Connection to resistor modules is shown in Table 2-1.

BUS SIGNAL	PIN	RESISTOR MOD PIN
BIRQ5L	AA1, CA1	RM1-2
BIRQ6L	AB1, CA1	RM1-3
BDAL16L	AC1, CC1	RM1-4
BDAL17L	AD1, CD1	RM1-5
BDMRL	AN1, CN1	RM2-4
BHALTL	AP1, CP1	RM2-6
BREFL	AR1, CR1	RM2-7
BDOUTL	AE2, CE2	RM1-6
BRPLYL	AF2, CF2	RM1-7
BDINL	AH2, CH2	RM1-8
BSYNCL	AJ2, CJ2	RM1-9
BWTBTL	AK2, CK2	RM2-2
BIRQ4L	AL2, CL2	RM2-3
BBS7L	AP2, CP2	RM2-5
BINITL	AT2, CT2	RM2-8
BDALOL	AU2, CU2	RM2-9
BDALIL	AV2, CV2	RM3-2
BDCOKH	BA1, DA1	RM3-3
BPOKH	BB1, DB1	RM3-8
BDAL18L	BC1, DC1	RM3-4
BDAL19L	BD1, DD1	RM3-6
BDAL20L	BE1, DE1	RM3-5
BDAL21L	BF1, DF1	RM3-7
BSACKL	BN1, DN1	RM4-8
BIRQ7L	BP1, DP1	RM4-6
BEVENTL	BR1, DR1	RM5-3
BDAL2L	BE2, DE2	RM3-9
BDAL3L	BF2, DF2	RM4-2
BDAL4L	BH2, DH2	RM4-3
BDAL5L	BJ2, DJ2	RM4-4
BDAL6L	BK2, DK2	RM4-5
BDAL7L	BL2, DL2	RM4-7
BDAL8L	BM2, DM2	RM5-5
BDAL9L	BN2, DN2	RM5-9
BDAL10L	BP2, DP2	RM5-8
BDAL11L	BR2, DR2	RM5-7
BDAL12L	BS2, DS2	RM5-6
BDAL13L	BT2, DT2	RM5-4
BDAL14L	BU2, DU2	RM5-2
BDAL15L	BV2, DV2	RM4-9

TABLE 2-1: TERMINATION RESISTOR CONNECTIONS

### 2.3.4 Module Alignment

All backplane versions include a cardframe assembly which supports installed modules and provides positive pin alignment. The modules plug into a bus connector, each with 36 lines per dual slot (18 each on component and solder sides of the board). Each slot includes an alphanumeric identifier. Refer to Figure 2-7 for row A through D identifiers. Take special care to ensure that the logic modules are not installed backward.

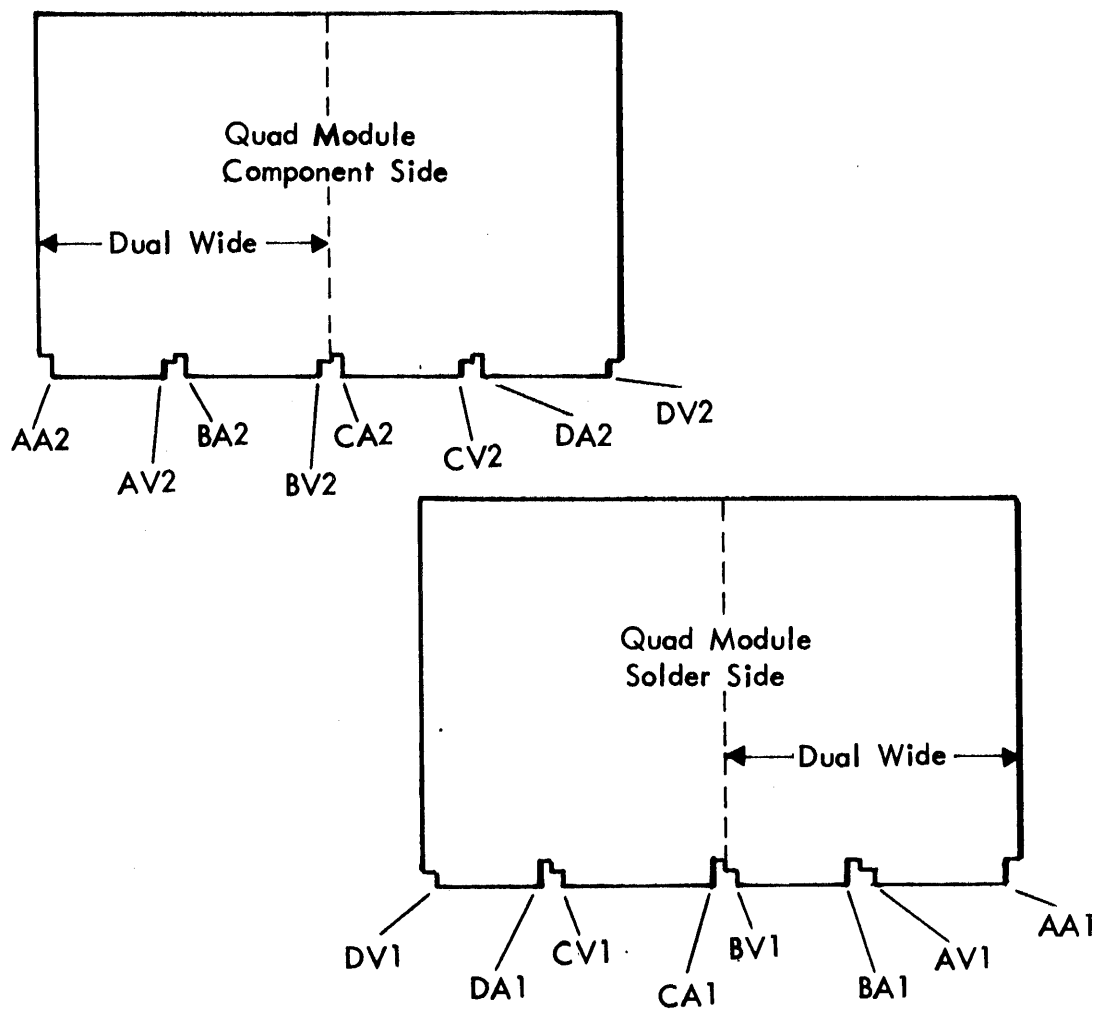

FIGURE 2-7: MODULE ALPHANUMERIC SLOT IDENTIFIERS

## 2.4 POWER SUPPLY

The power supply provides DC outputs and accepts 115VAC or 230VAC inputs. Output power is routed to the inner layers of the multilayered PWB on the backplane. Input power is factory configured but can be converted between 115/230VAC.

### 2.4.1 DC Backplane Power Connections

Attachment of DC power to the backplane is via power cables for 5VDC, 12VDC, -12VDC, 12V Battery, 5V Battery, and Ground. The two power tabs for 5VDC can accept up to 35A. Figure 2-6 illustrates the backplane power connections.

### 2.4.2 Front Panel Connections

Two 10-pin connectors are provided for interface to the user control signals. J9 pinout (bottom of backplane) and J10 pinout (module insertion side of backplane) are mirror images. The connectors are illustrated in Figure 2-8 and are defined in Table 2-2.

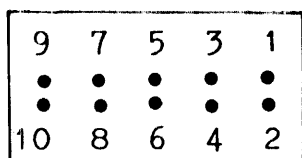

VIEWED FROM SOLDER SIDE OF BACKPLANE  
WITH POWER TABS ON RIGHTHAND SIDE.

FIGURE 2-8: J9 AND J10 CONNECTOR ILLUSTRATION

	PIN	SIGNAL DESCRIPTION
1	N/C	Option Pad
2	N/C	Option Pad
3	BDCOKH	Supplied by power supply to indicate DC voltage out of tolerance.
4	BHALT L	Supplied from front panel switch.
5	BEVENT L	Line frequency signal supplied by power supply to BEVENT line.
6	BPOKH	Supplied by power supply to indicate AC power condition.
7	N/C	Option Pad
8	SRUN	From processor to indicate RUN status on front panel
9	GND	
10	GND	

TABLE 2-2: J9 AND J10 FRONT PANEL CONNECTION

2.5 CHASSIS INSTALLATION

Use the following procedure to install the SA-H105Q into a standard 19" RETMA rack and to apply AC input power.

1. Remove the slides from the chassis by sliding the chassis out until the rear retaining spring buttons engage. Depress the springs and slip the slides completely free from the chassis. Set the chassis aside.
2. Place the slides in the rack, marking the intended position of the mounting holes both on the front and at the rear of the rack. Bolt the slides into place using 10-32 x 1/2" screws. Bolt the rear of the slides to the rack side rails using four 10-32 x 3/8" screws. All screws should use flat washers, with locking washers next to the screw head.
3. Check the chassis itself for proper AC power selection as defined in Section 1.7
4. Install the chassis on the slides. Plug the AC cord into a proper main receptacle and switch the power ON/OFF switch to the ON position. Check DC voltages as defined in Section 3. The voltages should be measured on the backplane. See Appendix for Q bus pin assignments and Section 2-3 for module insertion.

VOLTAGE	MEASUREMENT SOURCE
5VDC $\pm$ 0.25VDC	AA2,BA2,BV1
12VDC $\pm$ 0.60VDC	AD2,BD2

TABLE 2-3: DC VOLTAGE MEASUREMENTS

March 11, 1983  
Page 18

## SECTION 3 - VOLTAGE ADJUSTMENTS

---

### 3.1 GENERAL INFORMATION

The 5.25" system chassis consist of four major assemblies: display bracket, power supply, backplane and chassis. Service to any of these assemblies requires disassembly. It is recommended that the chassis be returned to the Sigma factory for service to the power supply except for voltage adjustments described in this section.

### 3.2 VOLTAGE ADJUSTMENTS

Voltages can be adjusted to within  $\pm 10\%$  of nominal by turning potentiometers clockwise for a decrease and counter-clockwise for an increase in voltage. Refer to Figure 3-1 for the location of voltage adjustment pots.



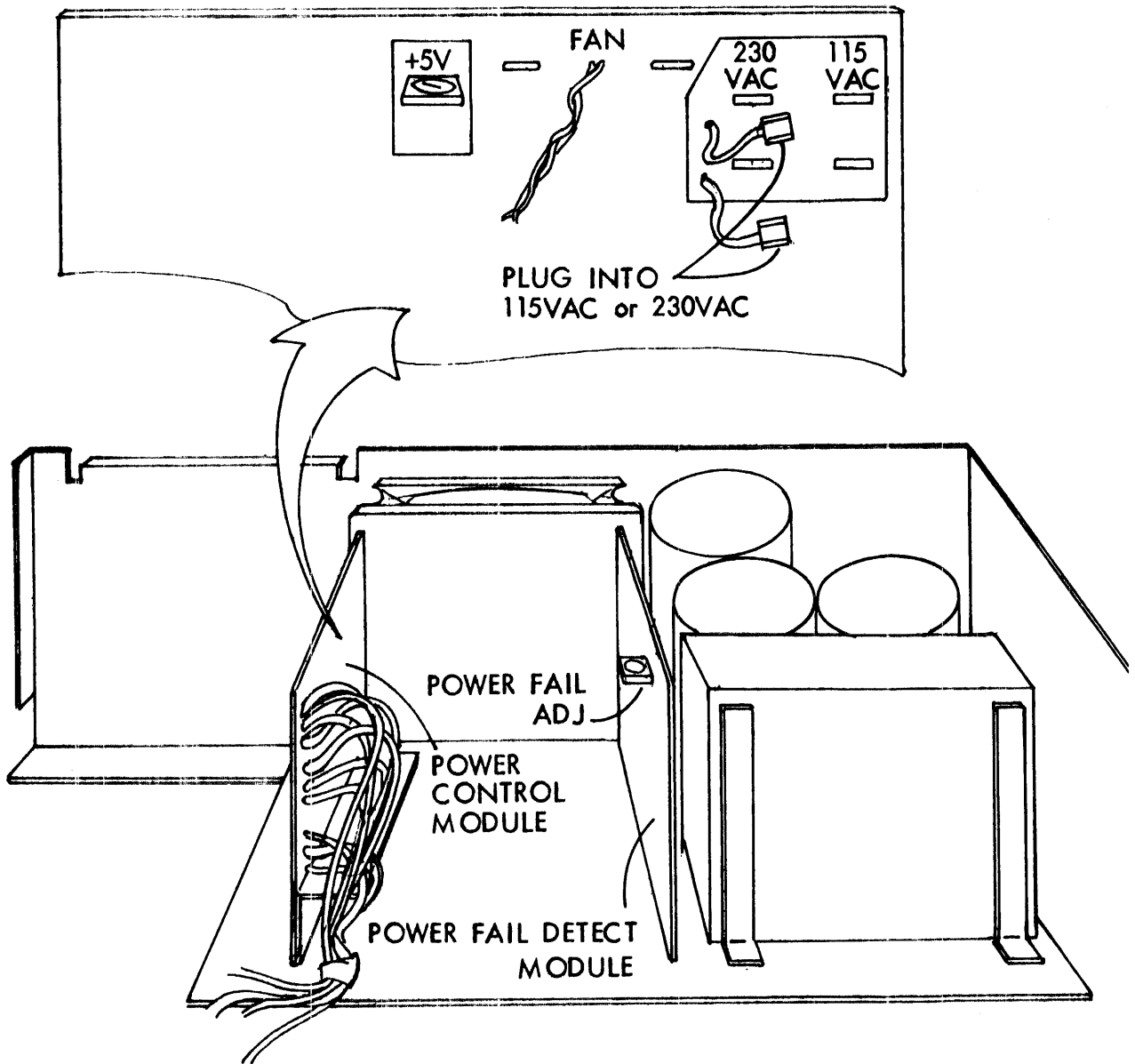

FIGURE 3-1: DC POWER ADJUSTMENT LOCATIONS

### 3.2.1 5VDC Adjustment

The 5VDC power is provided by a separate regulator module. Adjustment is made by turning the pot indicated in Figure 3-1. Measure 5VDC  $\pm$  0.25VDC on pin AA2, BA2, or BV1 of the backplane. If the output cannot be brought within the limits, or if the voltage adjustment pot is near its extreme limit when obtaining proper output voltage, the module must be replaced.

### 3.2.2 Power Fail Detect Adjustment

The power supply includes a power fail detect circuit which provides BPOKH and BDCOKH signals in the proper timing sequence to the Q bus. The power fail circuitry is designed to detect a 1/2 cycle drop-out on the AC line. The detection is done via a retriggerable one-shot that is retriggered on zero crossing and whose dwell slightly exceeds the duration of 1/2 cycle line frequency. Since line frequency can be either 50Hz or 60Hz, adjustment of the power fail detect signal should be check at time of installation.

Figure 3-1 shows the location of the power fail detect pot. Adjustment should be made by monitoring BB1. Note that pin BB1 should be high. If 5VDC and 12VDC are present and within tolerance, BPOKH should be high. If not, adjustment is necessary. Using a VOM, adjust the pot until pin BB1 can be observed going low. Then back off until pin BB1 remains high. Continue slightly beyond this point to provide extra margin.

Figure 3-2 shows the timing relationship of BPOKH and BDCOKH as provided by the power supply unit.

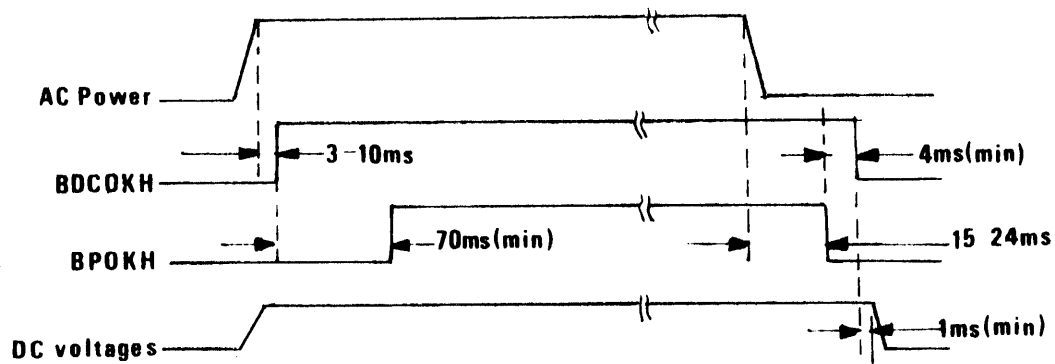

FIGURE 3-2: POWER FAIL DETECT TIMING

**BPOKH.** A signal signifying the status of AC power. If power fails in a 1/2 cycle drop-out or longer power outage, BPOKH is asserted on BB1. Both BPOKH and BDCOKH remain asserted (low) after power is off.

**BDCOKH.** A signal signifying the status of DC power on the Q bus, pin BA1. The signal must be asserted before DC power is lost and becomes valid after DC power is restored.

**LTC.** A line frequency signal used for timing on BR1.

### 3.3 ASSEMBLY/DISASSEMBLY

The SA-H105Q consists of four major assemblies: the display assembly, the power supply assembly, the backplane, and the chassis assembly. The chassis is designed such that each of these assemblies can be replaced independently using the following procedures. Replacement of components is in reverse order of the removal of the components. Refer to Figure 3-3.

#### 3.3.1 Removal of Chassis Assembly from Rack

- a. Disconnect the power cord.
- b. Disconnect or unplug any cables to installed modules.
- c. Slide chassis out until rear spring button release latches engage. Depress springs to release and slide out completely.

#### 3.3.2 Display Bracket Removal

- a. Pull out at bottom of front panel and remove.
- b. Disconnect the 10-pin cable and the remove ON/OFF cable plugged into the display bracket PCBA.
- c. Remove screws holding bracket to chassis and remove bracket.

#### 3.3.3 Power Supply Removal

- A. Remove the four No. 6-32 x 3/8 screws at the rear. Remove three No. 8-32 x 3/8 screws holding the power supply bracket to the chassis at the bottom.
- b. Disconnect the fan cables at the fans.
- c. Disconnect the 10-pin cable from J2 on the power supply regulator PCBA going to the backplane.
- d. Disconnect the 10-pin front panel cable from J1 on the regulator and control module.
- e. Disconnect the power ON/OFF cable from the front panel.
- f. Disconnect the 5V power cable at the backplane.
- g. Disconnect the 12V power cable at the backplane.
- h. Disconnect all drive cables at the drives.
- i. Slide out the power supply assembly from the rear.

#### 3.3.4 Backplane Removal

The backplane assembly can be removed by unscrewing the four No. 6-32 x 5/16 attaching screws from the bottom of the chassis. The backplane, card guides and fan are an integral assembly. Disconnect all attaching cables and lift out.





