

MANUAL 80

Teletype Corporation  
Chicago, Illinois, U.S.A.

Teletype Instruction Manual No. 80MA  
October, 1952

INSTRUCTION MANUAL FOR  
TELETYPE MODEL 31  
TT-30/AGA-1 AIRCRAFT TELETYPEWRITER  
TAPE PRINTER

CONTENTS

Bulletin 200, Issue 1 - - - - -	Sections
EE 615, 674, 675, 693	I General Description
	II Theory of Operation
	III Adjustments
	IV Lubrication
	V Probable Troubles
	VI Spare Parts
	VII Wiring Diagram
	VIII Figures
 Bulletin 1140B, Issue 1 - - - - -	 Parts Catalog
EE 668, 669, 700	

Printed in U.S.A.

BULLETIN NO. 200  
ISSUE I  
SEPTEMBER, 1947

# TELETYPE

## PRINTING TELEGRAPH SYSTEMS

### MODEL 3I TAPE PRINTER

#### SECTIONS

- I GENERAL DESCRIPTION
- II THEORY OF OPERATION
- III ADJUSTMENTS
- IV LUBRICATION
- V PROBABLE TROUBLES AND POSSIBLE CAUSES
- VI SPARE PARTS
- VII WIRING DIAGRAM
- VIII FIGURES



REG. U.S. PAT. OFF.  
CORPORATION

SUBSIDIARY OF  
*Western Electric Company*  
CHICAGO, U.S.A.

BULLETIN NO. 1140  
ISSUE 1  
OCTOBER, 1947

# TELETYPE

PRINTING TELEGRAPH SYSTEMS

PARTS  
MODEL 31 TAPE PRINTER



REG. U. S. PAT. OFF.  
CORPORATION

SUBSIDIARY OF

*Western Electric Company*

CHICAGO, U. S. A.

# TELETYPE

## PRINTING TELEGRAPH SYSTEMS

### MODEL 3I TAPE PRINTER

#### SECTIONS

- I GENERAL DESCRIPTION
- II THEORY OF OPERATION
- III ADJUSTMENTS
- IV LUBRICATION
- V PROBABLE TROUBLES AND POSSIBLE CAUSES
- VI SPARE PARTS
- VII WIRING DIAGRAM
- VIII FIGURES



REG. U. S. PAT. OFF.  
CORPORATION  
SUBSIDIARY OF  
*Western Electric Company*  
CHICAGO, U. S. A.



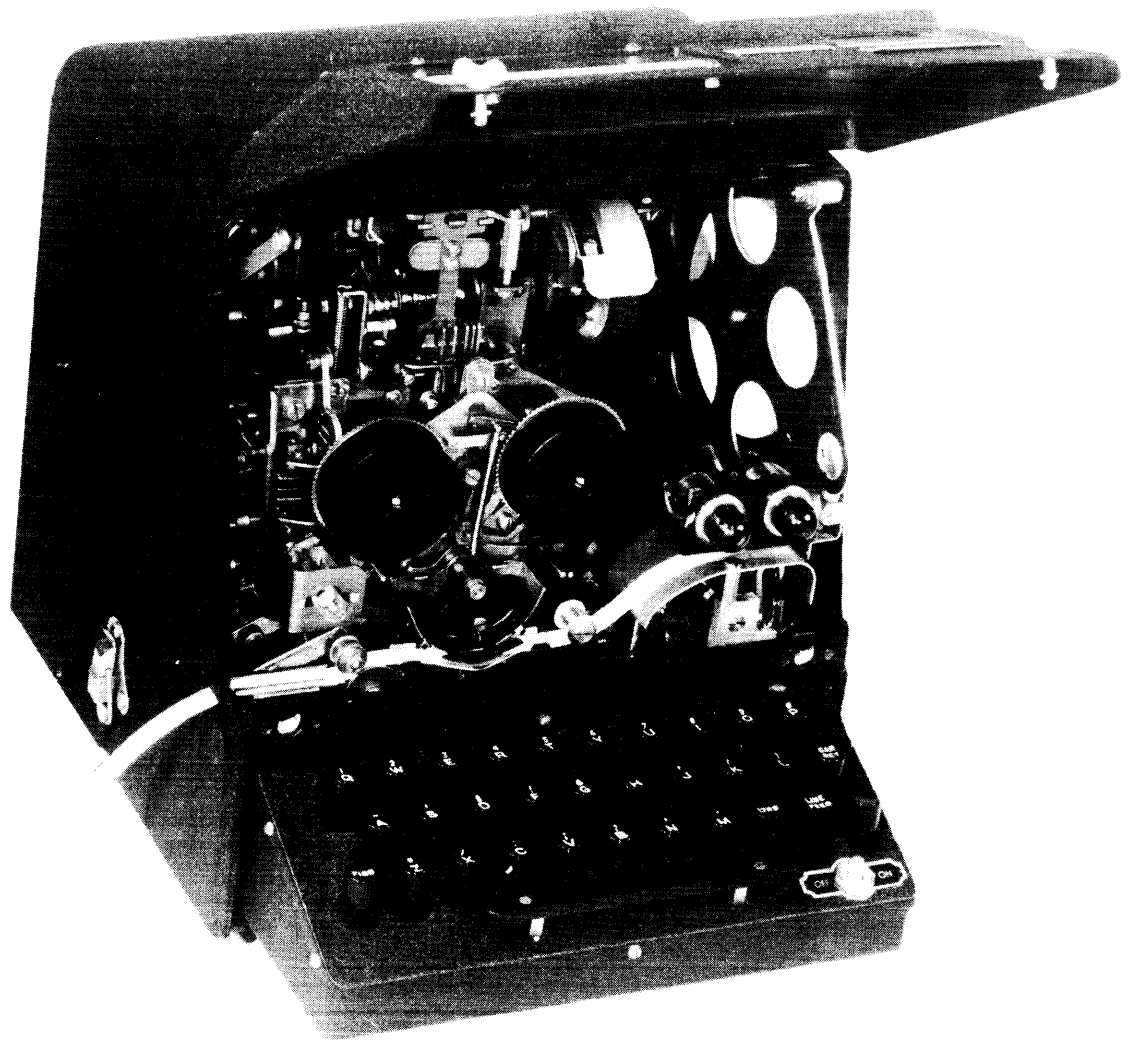

## TABLE OF CONTENTS

<u>Paragraph</u>	<u>Page</u>
SECTION I GENERAL DESCRIPTION	
1. General -----	1-1
SECTION II THEORY OF OPERATION	
1. Keyboard -----	2-0
2. Typing Unit -----	2-1
a. General -----	2-1
b. Synchronism -----	2-3
c. Printing -----	2-3
d. Spacing -----	2-3
e. Functions -----	2-3
f. Shifting -----	2-4
g. Printing on Carriage-Return and Line-Feed Combinations -----	2-4
h. Unshift-on-Space -----	2-4
i. Blank Function -----	2-4
j. Ribbon Feed Mechanism -----	2-5
k. End-of-Line Indicator Mechanism -----	2-5
SECTION III ADJUSTMENTS	
1. General Adjustments -----	3-0
2. Typing Unit -----	3-0
a. Typing Unit Proper -----	3-0
(1) Removal of Ribbon Mechanism -----	3-0
(2) Main Shaft End Play Adjustment -----	3-0
(3) Front Selector-Lever Guide Adjustment -----	3-0
(4) Main Shaft Position Adjustment -----	3-0
(5) Counter-Shaft Gears Adjustment -----	3-1
(6) Function-Clutch Trip Lever Spring Tension -----	3-1
(7) Function-Cam-Sleeve Driving-Pawl and Blocking-Pawl Spring Tension --	3-1
(8) Function-Cam-Sleeve Detent Spring Tension -----	3-1
(9) Code Disc Side Play Adjustment -----	3-1
(10) Code Disc Spring Tension -----	3-1
(11) Front Plate Adjustment -----	3-1
(12) Push-Bar Mounting Bracket Adjustment -----	3-1
(13) Type-Sector-Shaft Location Lever Guide Adjustment -----	3-2
(14) Type-Sector-Shaft Location-Lever Pivot Post Adjustment -----	3-2
(15) Type-Sector-Shaft Location-Lever Spring Tension -----	3-2
(16) Push-Bar Spring Tension -----	3-2
(17) Function-Bar Spring Tension -----	3-2
(18) Printing Shield Adjustment -----	3-2
(19) Function-Bar Reset-Cam-Follower Backstop Screw Adjustment -----	3-2
(20) Function-Bar Reset Screw Adjustment -----	3-2
(21) Function-Bar Reset-Cam-Follower Spring Tension -----	3-2
(22) Selector-Armature Pivot Plate Adjustment -----	3-3
(23) Selector-Magnet Yoke Adjustment -----	3-3
(24) Selector-Armature Pivot Clamp Adjustment -----	3-3
(25) Selector-Magnet-Bracket Adjusting Post Adjustment -----	3-3
(26) Selector-Cam-Sleeve Stop-Lever Spring Tension -----	3-3
(27) Selector-Lever Spring Tension -----	3-3
(28) Selector-Armature Locking-Lever Spring Tension -----	3-3
(29) Selector-Armature Spring Tension Adjustment -----	3-3

<u>Paragraph</u>	<u>Page</u>
(30) Push-Bar Stripper-Bail Eccentric Post Adjustment -----	3-4
(31) Push-Bar Stripper-Bail Spring Tension -----	3-4
(32) Centralizer Mechanism - Replacement of -----	3-4
(33) Centralizer Racks Adjustment -----	3-4
(34) Ribbon Guide Compression Spring Tension -----	3-4
(35) Centralizer-Bail Eccentric Stud Adjustment -----	3-4
(36) Centralizer Spring Tension -----	3-4
(37) Third-Pulse Bell Crank Adjustment -----	3-5
(38) Third-Pulse Bell Crank Spring Tension -----	3-5
(39) Printing Bail Adjustment -----	3-5
(40) Tape Guide Adjustment -----	3-5
(41) Printing-Bail Spring Tension -----	3-5
(42) Type-Sector-Shaft Stop Collar Adjustment -----	3-5
(43) Type-Sector Reset-Bail Spring Tension -----	3-5
(44) Type-Sector-Shaft Propulsion Spring Tension -----	3-5
(45) Shift-Plate Stop Bracket Adjustment -----	3-5
(46) Shift-Latch Eccentric Screw Adjustment -----	3-6
(47) Shift-Latch Spring Tension -----	3-6
(48) Shift-Plate Detent Spring Tension -----	3-6
(49) Printing-Bail-Link Eccentric Shoulder Screw Adjustment -----	3-6
(50) Printing Bail Extension Backstop Adjustment -----	3-6
(51) Printing Cam-Follower Spring Tension -----	3-6
(52) Suppressor-Lever Latch Plate Adjustment -----	3-6
(53) Suppressor-Lever Latch Spring Tension -----	3-6
(54) Suppressor-Lever Guide Adjustment -----	3-6
(55) Spacing Cam-Follower Extension Adjustment -----	3-7
(56) Spacing Cam-Follower Spring Tension -----	3-7
(57) Spacing-Pawl Spring Tension -----	3-7
(58) Spacing Push-Bar Spring Tension -----	3-7
(59) Spacing Detent Bracket Adjustment -----	3-7
(60) Spacing Detent Spring Tension -----	3-7
(61) Spacing Cam-Follower Up-Stop Screw Adjustment -----	3-7
(62) Tape-Pressure Roller Arm Adjustment -----	3-7
(63) Tape-Pressure-Roller Arm Spring Tension -----	3-7
(64) Ribbon Spool Shaft Pressure Adjustment -----	3-7
(65) Ribbon Overcentering Spring Tension -----	3-8
(66) Ribbon-Feed-Pawl Slide Adjustment -----	3-8
(67) Ribbon-Reverse-Lever Detent Spring Tension -----	3-8
(68) Type-Sector Reset-Bail Adjusting Screw Adjustment -----	3-8
(69) Selector Clutch Torque -----	3-8
(70) Motor Governor Brush Spring Adjustment -----	3-8
b. End-of-Line Indicator Mechanism -----	3-8
(1) Check-Pawl Eccentric Adjustment -----	3-8
(2) Feed-Pawl Lever Adjustment -----	3-8
(3) Stop-Pawl Eccentric Adjustment -----	3-8
(4) Release-Pawl-Lever Eccentric Adjustment -----	3-9
(5) Release-Pawl Latch Adjustment -----	3-9
(6) Ratchet Return Spring Adjustment -----	3-9
(7) Contact Adjustments -----	3-9
(8) Release Pawl Spring Tension -----	3-9
(9) Stop Pawl Spring Tension -----	3-9
(10) Check Pawl Spring Tension -----	3-9
(11) Release Lever Spring Tension -----	3-9
(12) Feed Pawl Spring Tension -----	3-9
(13) Contact Cam Adjustment -----	3-9



<u>Paragraph</u>	<u>Page</u>
3. Keyboard Unit -----	3-10
a. Adjusting Procedure -----	3-10
(1) Ratchet Wheel Sleeve End Play -----	3-10
(2) Locking Levers Adjustment -----	3-10
(3) Locking Loop Spring Tension -----	3-10
(4) Locking Loop Blade Adjustment -----	3-10
(5) Transmitting Contacts Gap Adjustment -----	3-10
(6) Contact Spring Pressure -----	3-10
(7) Release-Pawl Stop Screw Adjustment -----	3-10
(8) Trip-Pawl Adjustment -----	3-10
(9) Trip-Pawl Spring Tension -----	3-10
(10) Selector-Bar Roller Brackets Adjustment -----	3-10
(11) Clutch Pawls Spring Tension -----	3-10
(12) Repeat Space Rod Bracket Adjustment -----	3-11
(13) Key Lever Spring Tension Adjustment -----	3-11
(14) Universal Bar Spring Tension -----	3-11
(15) Typing Unit Position Adjustment -----	3-11

SECTION IV LUBRICATION

1. General -----	4-0
2. Typing Unit -----	4-0
3. End-of-Line Indicator -----	4-1
4. Keyboard -----	4-1
a. Lubrication on Bottom Side of Keyboard -----	4-1
b. Lubrication on Top Side of Keyboard -----	4-1

SECTION V PROBABLE TROUBLES AND POSSIBLE CAUSES

1. Errors in Selection -----	5-1
2. Defective Printing -----	5-1
3. Motor Speed Failure -----	5-1

SECTION VI SPARE PARTS

SECTION VII WIRING DIAGRAM

SECTION VIII FIGURES

## SECTION I

## GENERAL DESCRIPTION

## 1. GENERAL

a. The Model 31 Teletype Tape Printer is designed for use in types of service where weight and space considerations are limiting factors. In addition to being readily adaptable to land circuits, it is particularly suited to two-way aircraft-to-ground communication over radio-telephone facilities and operates without interfering with telephone communication. It is equally adaptable for use in automotive vehicles or water-borne craft. When applied to a radio-telephone circuit a converter-control unit (not furnished by Teletype Corporation) must also be used. When installed in an airplane the printer and the converter-control unit depend on the 26.5-volt battery commonly used in airplanes for their source of power. The signal line current may be derived from the converter-control unit. In such case the printer is driven by a 26-volt, governed, dynamotor. The generator winding of the dynamotor furnishes 250-volt plate current for the tubes of the converter-control unit. When the printer is used on land circuits a motor that operates on standard power supplies is furnished. The dimensions of the complete send-receive printer are - 10-1/2" high, 10-1/4" wide, 13-1/2" deep. The weight is approximately 23 lbs.

b. The Model 31 printer consists of a typing unit, a base, and a cover. The base may be of the receiving-only type or it may include a transmitting keyboard. The typing unit and cover are arranged for secure attachment to the base. The motor is mounted on the rear of the typing unit. A tape reel is located within the cover.

c. The typing unit comprises the selecting, printing, and associated functional mechanisms, including end-of-line indicating mechanism when required.

d. The keyboard transmits signal combinations of the start-stop five-unit code to the selecting mechanisms of all interconnected typing units. The received signals cause the

typing units to print a copy of the message transmitted by the keyboard operator.

e. The start-stop five-unit code (Figure 3) utilizes five selecting elements in combinations of current and no-current intervals to form thirty-two code combinations. In order to maintain synchronism between transmitting and receiving units, each group of five selecting intervals is preceded by a START interval and followed by a STOP interval. Intervals during which current is transmitted are designated as MARKING intervals and those during which no current is transmitted are designated as SPACING intervals.

f. On the typing unit, a selector cam sleeve (Figure 6) responds to the START and STOP intervals for synchronizing the receiving machine with the transmitting unit and actuates the selecting mechanism in timed relation to the code intervals. A function cam sleeve (Figure 6) times the action of printing and spacing mechanisms, and the operation of five function bars (Figure 1) placed horizontally on the front plate of the printer. The function bars control shifting of the type sector to FIGURES or LETTERS positions, suppression of printing and/or spacing as required, and the actuation of end-of-line signal mechanism when present.

g. The type sector (Figure 1) includes 120 degrees of arc with characters arranged in four parallel rows that follow the arc. Alternate characters in each row are made available for FIGURES and LETTERS selection. The type sector is moved parallel to its axis to bring the required row of characters over the printing hammer and is rotated toward left or right to bring the required character to the printing position. The first two code intervals, by determining the limits of forward travel, select the row of type for printing. The third code interval determines the direction of rotation of the type sector. The fourth and fifth intervals determine the extent of rotation necessary to bring the required character to the printing position.

SECTION II

THEORY OF OPERATION

1. KEYBOARD

a. The keyboard mechanism (Figures 2, 4, and 5) consists essentially of a set of key levers, selector bars, transmitting contact mechanism, transmitting cam sleeve, transmitting clutch, and transmitting gear. The transmitting gear engages a keyboard driving gear (Figure 1) on the counter shaft of the typing unit. The transmitting gear is mounted on the sleeve of the clutch ratchet wheel and causes the sleeve and ratchet wheel to rotate continually while the motor is running. The transmitting cam sleeve remains stationary except when rotary motion is extended to it from the clutch ratchet wheel. Engagement of the clutch is brought about by operation of any key lever or the space bar. Keyboard operation causes a driving pawl and a blocking pawl (Figure 5), which are mounted on a drive arm attached to the transmitting cam sleeve, to engage the clutch ratchet wheel and initiate a transmitting cycle.

b. Pressure on a key lever or the space bar causes it to strike the inclined planes on the upper surfaces of five selector bars (Figure 4) and a universal bar (Figure 5). The selector bars assume positions, to right or left, corresponding to the code combination of the key depressed. Selector bars that move toward the right, position locking levers which are located vertically between the bars, so as to clear the ends of associated contact levers (Figure 4) in order to produce MARKING code intervals. Selector bars that move toward the left, position locking levers so as to engage the ends of associated contact levers and restrict their motion in order to produce SPACING code intervals.

c. Pressure of a key lever on the universal bar moves it toward the left against the tension of its spring. A stud on the rear side of the universal bar actuates a release lever (Figure 5) that pivots at center and, by means of a trip pawl attached to its upper end, applies pressure on the release pawl. The release pawl, under pressure from the trip pawl, disengages from the driving pawl of the clutch and allows both the driving pawl and the blocking pawls to engage the ratchet-wheel teeth. The driving pawl brings the cam sleeve

into rotation while the blocking pawl prevents its moving faster than the ratchet-wheel.

d. Code impulses are transmitted from the five forward contacts (numbered from rear to front). The start-stop contact occupies a position to the rear of No. 1 code contact. On keyboards arranged for radio transmission, a contact for conditioning radio equipment for either transmission or reception of signals is located to the rear of the start-stop contact. Two lamps (Figure 2) (red and green) located above the transmitting contacts are wired for connection with the radio equipment and indicate whether it is conditioned for transmission or reception. Illumination of the red lamp indicates a transmitting condition, whereas the green indicates a receiving condition.

e. With the start of transmission the start-stop contact opens and the radio equipment conditioning contact closes. As the indents on cams one to five of the transmitting cam sleeve move to the underside consecutively, the unlocked contact levers rise into the indents and allow corresponding contacts to close. Following the fifth code interval of transmission, the start-stop contact closes and the conditioning contact opens. The driving pawl rotates to the stop position where it is blocked by the release pawl. Blocking action of the release pawl causes both the driving and blocking pawls to release from the clutch ratchet wheel and hold the transmitting cam sleeve stationary.

f. Located above and to the rear of the locking levers is a locking loop (Figure 4). An arm of this loop rides a cam located between the fourth and fifth transmitting cams. When the cam sleeve is in its stop position, the arm of the locking loop rides the peak of its cam and lifts the bail from the locking levers which are then free to respond to a key stroke. With the start of transmission, the locking loop drops on the locking levers and retains them in a set position. This prevents a key from being subsequently depressed while the code combination set up by the previous key stroke is being transmitted.

g. In order to prevent repetition of transmission when a key is held depressed, the

driving pawl rotates against a camming surface on the trip pawl (Figure 5) and disengages the trip pawl from the release pawl. The release pawl then returns to the blocking position and disengages the clutch.

h. Repetition of transmission is effective, however, when the space bar is held depressed. In this case the space key lever actuates a space-repeat rod. A link connects the bracket of the space-repeat rod to the release pawl and holds the release pawl clear of the drive pawl for continuous rotation.

## 2. TYPING UNIT

### a. GENERAL

(1) Motive force is extended from the motor through the counter shaft to the main shaft of the typing unit (Figure 1). The main shaft carries the selector cam sleeve on its central portion and the function cam sleeve on the left. A driving torque is exerted on the selector cam sleeve by friction clutches (Figure 6) located at each end of the sleeve. The driving member of the left friction clutch is machined in the form of a ratchet wheel to provide a driving surface for clutch pawls assembled on the function cam sleeve.

(2) The selector cam sleeve comprises (from right to left) a stop disc, a reset cam, and five selector-lever cams with a locking-lever cam and a trip-lever cam interposed. See Figure 6. The locking-lever cam is located between the third and fourth selector-lever cams while the trip-lever cam is located between the fourth and fifth.

(3) A selector clutch lever (Figure 7) mounted on a stud in an adjustable range finder is provided with two arms. One arm rides the reset cam on the selector cam sleeve and engages a slot in a start-stop lever. The start-stop lever extends forward to meet the armature extension of the selector magnet. The other arm of the selector clutch lever extends above the right friction clutch (Figure 6). With the selector magnet energized, the armature extension blocks the start-stop lever which prevents the selector clutch lever from following its cam, and causes the upper arm of the selector clutch lever to hold the selector cam sleeve stationary by blocking the rotation of the stop disc.

(4) With the selector cam sleeve in the stop position, the cam follower arm of the trip lever (Figure 6) rests on the low part of its cam and holds its blocking arm in the path of

the driving pawl associated with the function cam sleeve. Blocking of the outer end of the driving pawl causes its opposite end to swing clear of the ratchet wheel teeth. A stud in the side of the driving pawl likewise holds the blocking pawl disengaged. Under these conditions the function cam sleeve is held stationary.

(5) From an idling condition, under which the main shaft rotates with the selector magnet energized and the selector and function cam sleeves held stationary, the selecting cycle is initiated by the reception of the start interval (no current - SPACING). The armature (retracted by its spring) permits the start-stop lever to follow its cam and actuate the selector clutch lever which releases the selector cam sleeve and permits it to rotate. During rotation of the sleeve, the armature is attracted by the magnet in response to each MARKING interval of the code. Assuming that the code combination representing the Y character is being applied to the magnet, the first, third and fifth intervals will be MARKING (current) but the second and fourth will be SPACING (no current). During the first interval, the armature is held attracted while the No. 1 selector lever rises into the indent of its cam. A locking lever (Figure 7) limits the over-all movement of the armature and rises in time with each selector lever so as to lock the armature in either the MARKING or SPACING position while the selector levers are being presented to it. With the armature attracted, No. 1 selector lever rises sufficiently to allow the shoulder of No. 1 push bar (a push bar stands vertically at the forward end of each selector lever and is tensioned against it) to move under its forward end. See Figure 8. No. 1 selector lever immediately moves its push bar downward and holds it in that position (MARKING) while riding the high portion of its cam. In a like manner, the third and fifth push bars are held downward in response to MARKING intervals. The second and fourth push bars remain undisturbed since the armature extension, in response to SPACING intervals, block the rise of the second and fourth selector levers. In the MARKING position No. 1 push bar contacts No. 1 location lever (Figure 9) and holds it and the common location lever clear of the stop collar on the type-sector shaft. Actuation of these location levers clears the way for the type-sector shaft to move forward and utilize the third-from-the-front row of type on the type sector during the printing cycle.

(6) Movement of the type-sector shaft is controlled by a reset bail (Figures 9 and 10)

and a rotating mechanism (Figure 11). When the function cam sleeve is in its stop position, an eccentric drive link (Figure 10) holds a centralizer bail tilted at an angle so as to cause the bail to press its lower extension against the adjusting screw of the reset bail and hold it in the operated position. In the operated position, the reset bail engages the stop collar on the type-sector shaft and holds the shaft and type sector in the rearmost position against the tension of two propulsion springs which are hooked to a link that forms a bearing at the rear end of the shaft.

(7) When none of the location levers are displaced by push bar action during the selecting cycle, the shaft comes to rest with the stop collar against the rearmost location lever during the printing cycle. The foremost row of characters is then in line with the printing hammer (Figure 13). With the displacement of the rearmost and each successive location lever in a cumulative manner, corresponding rows of characters are presented to the printing hammer until finally with all three levers displaced, the stop collar on the shaft is propelled against a stationary stop (Figure 10) and characters in the rear row on the type sector are utilized.

(8) Operation of No. 1 push bar only of the first pair, as in the case of Y selection, displaces both No. 1 and No. 2 location levers (Figure 9) since Y is located in the third row of characters. Operation of No. 2 push bar only would displace No. 1 and the common (rearmost) lever; whereas, operation of No. 1 and No. 2 push bars in sequence would remove all three levers from the path of the stop collar.

(9) A pinion that forms a sleeve on the type-sector shaft is located forward of the front plate. See Figure 11. This pinion is engaged by a separate rack on each side. The racks present notches on their inner edges to the lower end of a rack pawl which is connected by a spring to the centralizer bail arm. To aid in motivating the rack pawl, a push rod is confined within the helix formed by the spring. The rack pawl is pulled upward by the spring and pushed downward by the push rod as the centralizer bail responds to the action of the eccentric drive link (Figure 10) during the operating cycle. In order that the direction of the type sector's rotation may be predetermined, the sidewise movement of the rack pawl is controlled from a third-pulse bell crank (Figure 11). The horizontal extension of the bell crank rests

against a shoulder on No. 3 push bar while its lower extension engages a projection on the under side of the rack-pawl slide. The rack-pawl slide is supported and guided in its motion by two studs located in the printer front plate. A notch in the lower surface of the slide accommodates a stud projecting from the rear surface of the rack pawl. Tension exerted by a spring hooked to the horizontal extension of the third-pulse bell crank causes the pawl to be held normally in the notch of the right-hand rack. See Figure 11. Thus, rotation of the type sector will be counter-clockwise when the third code interval is SPACING. When the third code interval is MARKING, as in the case of Y, the downward movement of No. 3 push bar is applied to the bell crank which causes the rack pawl to engage the left-hand rack and apply clockwise motion to the type sector during the printing cycle.

(10) The stop position of the type sector relative to its rotary motion is determined by the positions of three code discs and a shift plate on which the code discs are mounted. See Figure 12. The shift plate pivots on a bushing which forms a bearing for the type-sector shaft where it passes through the front plate. The code discs provide an opening for the type-sector shaft and present blocking surfaces to the type-sector stop arm. Each code disc has two blocking surfaces; one toward the right and the other toward the left. The rear disc is effective in stopping the type sector near center; the middle and front discs stop the type sector progressively farther from center. When utilizing the extreme end characters, the shift plate alone provides the blocking surfaces. To permit printing of both figures and letters, the shift plate rotates sufficiently to bring alternate characters to the printing position. This rotary motion is limited by a notch in a shift stop bracket into which a shift-plate arm (Figure 13) extends. A shift-plate latch retains the arm in either the figures or letters position. By means of this arrangement, sixteen printing positions are made available for each of the four rows of type. The code discs are held in position by three guide screws (Figure 12) that permit perpendicular movement and are tensioned upward by means of springs.

(11) Operation of No. 4 push bar displaces the rear and middle code discs leaving the front disc effective in stopping rotation of the type sector. Operation of No. 5 push bar, as in the case of Y selection, displaces both the front and rear code discs and leaves the middle disc effective. Operation of both No.

4 and No. 5 push bars displaces the three code discs and leaves the shift plate effective in stopping the type sector. When neither push bar is operated, the rear code disc is effective.

#### b. SYNCHRONISM

In order for the code signals to be properly utilized in the typing unit the selecting mechanism must operate in synchronism with the code signals received. This becomes automatic when the speed of the motors is correctly set and when the index arm of the range finder is correctly positioned. Transmission of code signals is controlled by the cam indents on the transmitting cam sleeve. Movement of the selector levers is controlled by indents on the selector cam sleeve. Synchronism is made effective by causing each selector lever to move in timed relation to the corresponding element of the code. This is brought about by driving the selector cam sleeve one-seventh faster than the transmitting cam sleeve; by stopping the selector cam sleeve on the STOP interval at the end of each selecting cycle so that it may be started by the START interval in correct relation to the transmitting cam sleeve at the beginning of the transmitting cycle; and by having the indents on the selector cam sleeve spaced a distance one-seventh greater between centers than the cam indents of the transmitting cam sleeve. This difference in spacing compensates for the difference in speeds. In the intervals between the start and the stop, correct relation is maintained by regulated motor speed.

#### c. PRINTING

(1) During the fifth code interval, the trip lever (Figure 6) rides into the indent of its cam and trips the driving pawl on the function cam sleeve. This action allows both the driving and the blocking pawls to engage the teeth of the clutch ratchet wheel. The teeth on which the driving pawl rests face in the direction of rotation and motivate the function cam sleeve. The teeth on which the blocking pawl rests face in the opposite direction and prevent the cam sleeve from rotating faster than the ratchet wheel.

(2) As the function cam sleeve starts to rotate, the centralizer eccentric (Figure 6) actuates the centralizer bail (Figure 10) which raises the rack pawl (Figure 11) by means of the spring hooked between the forward extension of the bail and a stud on the lower end of the pawl. The rack pawl is rising engages a rack which rotates the type

sector a distance predetermined by the setting of the code discs and the shift plate. While the rack pawl is rising, a lower extension on the centralizer bail withdraws from the type-sector reset bail (Figure 10) and permits the type-sector shaft to move forward to a position predetermined by the setting of the location levers. After the movement of the type-sector shaft brings the selected character to the printing position, the push bar stripper bail (Figure 8) rides to the peak of its cam and strips the operated push bars off the ends of the selector levers. Immediately after the push bars are stripped from the selector levers, the printing cam follower (Figure 14) drops to the low part of its cam under tension of its spring. The printing cam follower is linked to a printing bail mounted on a shaft extending between the side frame castings. A forward extension of the printing bail carries a printing hammer. As the printing cam follower responds sharply to the cam drop-off, its spring action is extended through the link to the printing bail to effect the printing blow. Following the printing of a character, the centralizer bail (Figure 10) is restored to its idling position by the centralizer eccentric. During this action the type sector is withdrawn clear of the printed copy and is rotated to a central position due to the pressure applied to the upper ends of both racks by collars (Figure 10) attached to the forward end of the centralizer bail. As the type sector reaches its central position, the driving pawl on the function cam sleeve is engaged by the trip lever to stop rotation of the sleeve.

#### d. SPACING

The tape on which the printed copy is recorded unwinds from a reel located within the printer cover. It is threaded through a tape guide (Figure 1), under a printing shield, and between the feed and pressure rollers mounted to the left of the guide. The feed roller shaft extends through a bearing in the front plate and supports a spacing ratchet wheel (Figure 15) on its rear end. A spacing pawl pivoted on a spacing push bar that is actuated by a spacing cam follower located at its upper end, advances the spacing ratchet wheel. A detent lever and roller insures accurate spacing of the characters on the tape.

#### e. FUNCTIONS

(1) Five function bars (Figure 16) anchored at the right side of the front plate are tensioned against a function-bar bail that pivots at the left side of the front plate. The push

bars present coded surfaces to the function bars and select them individually when functional code combinations are applied. When the function cam sleeve is in its stop position, the function bars are held clear of the push bars by the function bar bail which is actuated by a reset lever that rides a function reset lever cam on the function cam sleeve. During the rotating cycle of the sleeve the function bar bail withdraws from the function bars and permits unselected bars to rest against the push bars. When a function bar enters into selection with the push bars it comes to rest against the front plate at its left end.

(2) A print-suppression lever and a space-suppression lever mounted vertically behind the front plate present coded surfaces to the function bars through an opening at the left side of the front plate. See Figure 16.

(3) When the suppression of printing is required on a function, the function bar selected actuates the print-suppression lever and causes it to hook over a projection on the printing link (Figure 14) so as to restrict its movement.

(4) When suppression of spacing is required on a function, the function bar selected actuates the space-suppression lever and causes it to hook over a forward projection on the spacing push bar (Figure 15) and restrict its movement.

(5) Each suppression lever is equipped with a latch (Figure 16) that extends horizontally rearward and engages a latch plate, attached to the under side of the upper casting, when the suppression levers are operated. The latches retain the suppression levers in the operated position until completion of the operating cycle. At the end of the operating cycle a sidewise projection on the spacing push bar disengages both latches from the latch plate.

#### f. SHIFTING

(1) In order to utilize both figures and letters characters on the type sector, the shift plate (Figure 12) is rotated clockwise by the type-sector stop arm in response to LETTERS combination and counter-clockwise in response to FIGURES combination.

(2) When all five push bars are operated in response to LETTERS combination, code notches on their lower sections permit the selection of the lower function bar only. See Figure 16. While being selected, the lower function bar actuates the shift plate latch, the print

suppression lever, and the space suppression lever (Figures 13 and 16). The shift plate is positioned vertically near the left end of the function bars. With the shift-plate latch held clear of the shift-plate arm the shift plate is rotated to the LETTERS position by the clockwise rotation of the type-sector stop arm. Printing and spacing are suppressed by the action of the suppression levers. As the lower function bar is restored to its unoperated position, the shift-plate latch becomes effective in holding the shift-plate arm in the letters position.

(3) When the FIGURES combination is applied to the push bars, the lower function bar is again selected but the rotation of the type sector and shift plate is counter-clockwise since the third code interval is SPACING. Printing and spacing are suppressed as in the foregoing.

#### g. PRINTING ON CARRIAGE-RETURN AND LINE-FEED COMBINATIONS

Application of CARRIAGE-RETURN combination to the push bars selects the carriage-return function bar (second from the top) (Figure 16). The application of LINE-FEED combination selects the function bar second from the bottom. In order to permit printing of special marks to indicate that CARRIAGE-RETURN and LINE-FEED combinations have been transmitted, the space and print suppression levers (Figure 16) are so coded as to be insensitive to the selection of carriage-return and line-feed function bars. When printing and spacing is not required on these functions, special suppression levers may be supplied which are so coded as to respond to the operation of these two function bars and suppress printing and spacing.

#### h. UNSHIFT-ON-SPACE

When SPACE combination is applied to the push bars, the third function bar (numbered from the bottom) is selected. This function bar actuates the shift-plate latch and the print suppression lever but leaves the space suppression lever undisturbed. See Figures 13 and 16. The shift plate will be rotated to the letters position simultaneously with spacing provided it had been in the figures position.

#### i. BLANK FUNCTION

When the BLANK combination is applied to the push bars the upper function bar (Figure 16) is selected. In order to permit printing and spacing on BLANK selection, if desired,

corresponding suppression levers must be used.

j. RIBBON FEED MECHANISM

(1) The forward end of the centralizer bail engages a slot in the ribbon-feed pawl slide (Figure 17) and motivates it. The ribbon feed pawl pivots on the lower end of the slide and is held in engagement with one or the other of two ribbon-feed ratchet wheels by a feed-pawl spring. The feed pawl advances the ratchet wheel one tooth for each cycle of the function cam sleeve and rotates the ribbon spool attached to the ratchet shaft. A check pawl located below the feed pawl prevents backward rotation of the ratchet wheel.

(2) Reversal of direction of ribbon feeding is brought about when a rivet near each end of the ribbon comes in contact with a ribbon arm of the ribbon-reverse lever. The ribbon-reverse lever has two ribbon arms and two reversing arms. A detent lever rides a stud at the end of the left ribbon arm. Pressure of the ribbon rivet on a ribbon arm of the reverse lever causes the reverse lever to shift over center on its detent and present a reversing arm to the feed pawl. On the subsequent stroke of the feed-pawl slide, the reversing arm causes the upper end of the feed pawl to shift to the opposite ratchet wheel while the lower end reverses the check pawl so that it engages the same ratchet wheel as the feed pawl. A friction washer located on the inner end of the ratchet-wheel shaft prevents the free ribbon spool from unwinding too rapidly.

k. END-OF-LINE INDICATING MECHANISM

In order to permit interoperation with page printers, the Model 31 tape printer is equipped with end-of-line indicating mechanism and lamp, when required, to signal the keyboard operator for the transmission of CARRIAGE-RETURN and LINE-FEED signals. This mechanism is attached to the left side of the printer with the lamp visible to the operator above the left tape guide. See Figure 18. A lamp contact in series with the lamp circuit is actuated by a contact cam attached to a ratchet-wheel shaft. The ratchet wheel is advanced by a feed pawl and retained in position by a check pawl. The feed pawl is attached to a feed-pawl lever which is actuated by an extension on the spacing push bar so as to cause the ratchet wheel to advance one tooth for each spacing operation of the printer. As the ratchet wheel advances, it winds a spring and closes the lamp contact after reaching a position predetermined by the adjustment of the contact cam (normally 65 characters). With the transmission of CARRIAGE RETURN at the end of a line, an extension on the carriage-return function bar, which is then selected, actuates a release-pawl lever. A release pawl mounted on the release-pawl lever engages a latch and causes both the feed pawl and check pawl to be held clear of the ratchet wheel. As the ratchet wheel is returned to the starting point by its spring, a stop arm on its inner side engages a stop pawl. This stop pawl is provided with an elongated mounting hole and a spring to permit sliding action of the pawl and cushion the return of the ratchet wheel. On reaching its stop position, the stop arm on the ratchet wheel bears against the vertical arm of a release lever and causes the horizontal arm to trip the release pawl off its latch.



SECTION III

ADJUSTMENTS

1. GENERAL ADJUSTMENTS

a. The following adjustments are arranged in a sequence that would be followed if a complete readjustment of a unit were undertaken. In following such a procedure, parts or assemblies which are removed to facilitate adjustment should not be replaced until all other adjustments are made which would be facilitated by the removal of these parts. If any adjustment is changed, related adjustments should be checked.

b. The spring tension values indicated herein are scale readings which should be obtained when Teletype scales are used as specified. Springs which do not meet the requirements specified and for which no adjusting procedure is given should be replaced by new springs.

c. Before proceeding with any adjustment, read the applicable portion of the adjusting text carefully. After the adjustment is completed, be sure to tighten any screws or nuts which may have been loosened. If a part that is mounted on shims is to be dismantled, the number of shims used at each of its mounting screws should be noted so that the same shim pile-ups can be replaced when the part is re-mounted.

2. TYPING UNIT

a. TYPING UNIT PROPER

(1) Remove the ribbon and the ribbon mechanism assembly (Figure 1) from the typing unit as follows:

(a) Loosen the two upper mounting screws about two and one-half turns (accessible through the holes in the ribbon ratchet wheels) and remove the two lower mounting screws.

(b) Turn the main shaft until the centralizer bail arm (Figure 1) is in its uppermost position. Slide the assembly upward and off the typing unit.

(2) MAIN SHAFT END PLAY ADJUSTMENT (Figure 19)

The main shaft should have some end play,

not over .003", as measured between the left end of the left bearing and the adjacent washer. To adjust, add or remove shims between the thrust washer and the right end of the left bearing.

(3) FRONT SELECTOR-LEVER GUIDE ADJUSTMENT

Each selector lever should operate freely in its guide. To adjust, position the front selector lever guide (Figure 1) by means of its two mounting screws.

(4) MAIN SHAFT POSITION ADJUSTMENT

(a) The main shaft (Figure 1) and its bearings should be positioned to meet the following requirements:

1. The selector cam sleeve followers should ride fully on their respective cams when the side play of the followers is taken up in either direction.

2. The function cam sleeve followers should ride on their respective cams by at least three-quarters of their thickness, as gauged by eye, when their play is taken up in either direction.

3. The right bearing should be positioned so that the oil hole is at the top of the bearing and the left bearing should be positioned with the oil hole as near the top as possible within the limit of the slot that engages the locating screw. See Figure 19.

4. When the side play of any function cam sleeve follower is taken up in either direction, the follower must not ride on an adjacent cam.

(b) To adjust, loosen the bearing clamp screws and position the main shaft by means of the left bearing locating screw (Figure 19) and its lock nut. Then position the bearings according to requirement 3 and tighten the bearing clamp screws.

NOTE

In order to obtain requirement 4, it may be necessary to position the

detent lever (Figure 21) by means of its mounting bracket screws.

(5) COUNTER-SHAFT GEARS ADJUSTMENT

There should be a barely perceptible amount of backlash between the motor pinion and the highest point on the counter-shaft gear, and between the highest point on the main-shaft gear and the counter-shaft pinion. To adjust, position the counter-shaft bracket on its mounting screws. See Figure 1 for location of parts.

(6) FUNCTION-CLUTCH TRIP LEVER SPRING TENSION (Figure 20)

With the function-clutch trip lever on the low part of its cam but not engaging the clutch-driving-pawl stop arm, hook an 8 oz. scale under the stop extension of the lever and pull at approximately right angles to the spring. It should require 1/2 to 1-1/2 ozs. to start the trip lever moving.

(7) FUNCTION-CAM-SLEEVE DRIVING-PAWL AND BLOCKING-PAWL SPRINGS TENSION (Figure 20)

Rotate the function cam sleeve until the clutch driving-pawl and blocking-pawl springs are above the ratchet wheel in a horizontal position. Hook an 8 oz. scale to each pawl at the spring hole and pull in line with the spring. It should require 3-1/2 to 4-1/2 ozs. to start each pawl moving.

NOTE

When checking the driving-pawl spring, rotate the shaft backward until the ratchet wheel is stopped by the clutch blocking pawl and hold the blocking pawl away from the driving-pawl stud.

(8) FUNCTION-CAM-SLEEVE DETENT SPRING TENSION (Figure 21)

With the function-cam-sleeve detent lever on the high part of its cam, apply the push end of a 32 oz. scale to the top of the lever just behind the spring and push vertically downward. It should require 10 to 14 ozs. to start the lever moving.

UNHOOK THE CENTRALIZER SPRING (FIGURE 11) AT THE POST ON THE RACK PAWL. REMOVE THE TYPE SECTOR, LOOSEN THE RIBBON-GUIDE RETAINER MOUNTING SCREWS AND REMOVE THE RIBBON GUIDE (FIGURE 1). REMOVE THE RIBBON-GUIDE SPRING, THE CENTRALIZER MECHANISM (TWO SCREWS AND

TWO POSTS), THE RACK-PAWL SLIDE (FIGURE 11) AND THE TYPE-SECTOR STOP-ARM ASSEMBLY (FIGURE 22) FROM THE TYPING UNIT.

(9) CODE DISC SIDE PLAY ADJUSTMENT (Figure 22)

The code discs should be free in their guides and the code disc with the least amount of side play should have not more than .002" as judged by feel. To adjust, position the upper left code-disc guide and tighten its mounting screw.

(10) CODE DISC SPRING TENSION (Figure 22)

It should require 1/2 to 1-1/2 ozs. to start each code disc moving when an 8 oz. scale is hooked over the bottom inner edge of the code disc alongside the lower code-disc guide and pulled vertically downward. When measuring the middle and rear code discs, hold the other (front) code discs downward out of the way.

REPLACE THE TYPE-SECTOR STOP-ARM ASSEMBLY.

(11) FRONT PLATE ADJUSTMENT (Figures 1 and 22)

With the main shaft in the stop position and the No. 4 and No. 5 push bars selected by pushing them downward and hooking them under their selector levers, there should be .005" to .020" clearance between the bottom of the type-sector stop arm and the inner edge of the front or middle code disc (whichever has the least clearance), when the stop arm is in its extreme position in both directions. To adjust, loosen the two eccentric mounting screws (at the lower corners of the front plate) and move them out of the way. Then position the front plate, tighten its mounting screws and move the eccentrics to where they touch the upper portion of the notches on the front plate. In positioning the front plate, make sure that the push bars align with their respective selector levers.

NOTE

The eccentrics are provided so that the front plate may be removed and replaced without disturbing the vertical adjustment.

(12) PUSH-BAR MOUNTING BRACKET ADJUSTMENT (Figure 23)

With each selector lever in turn on the low

part of its cam, determine which selector lever rises the least above the shoulder on its push bar when the shoulder has moved under the selector lever. The selector lever with the least rise should clear the shoulder by .020" to .035". To adjust, position the push bar mounting bracket on its two mounting screws which are accessible from the rear of the typing unit.

(13) TYPE-SECTOR-SHAFT LOCATION LEVER GUIDE ADJUSTMENT (Figure 24)

With the main shaft in the stop position, operate the function-cam-sleeve clutch trip lever (Figure 20) by hand. Then hold the selector armature (Figure 31) operated and rotate the main shaft until the centralizer bail arm (Figure 34) is in its uppermost position. Trip the three location levers, allowing the stop collar to come forward against the stationary stop on the location-lever guide. In this position there should be .030" to .040" clearance between the upper surface of the stationary stop and the small shoulder on the stop collar. To adjust, position the location lever guide on its two mounting screws.

(14) TYPE-SECTOR-SHAFT LOCATION-LEVER PIVOT POST ADJUSTMENT (Figure 25)

With the selector and function cam sleeves in their stop positions, operate the function cam-sleeve clutch-trip lever by hand. Then hold the selector armature operated and rotate the main shaft until the centralizer bail arm is in its uppermost position. Under these conditions, there should be .015" to .040" clearance between the common location lever and the small shoulder on the stop collar. To adjust, position the location-lever pivot post and tighten its mounting screw.

(15) TYPE-SECTOR-SHAFT LOCATION-LEVER SPRING TENSION (Figure 25)

With the selector and function cam sleeves in their stop positions, hook an 8 oz. scale over the common location lever at the spring hole and pull in line with the spring. It should require 1 to 3 ozs. to just start the lever moving. Then hold the common location lever out of the way and check the other two location lever springs for this requirement.

(16) PUSH-BAR SPRING TENSION (Figure 23)

With the selector and function cam sleeves in their stop positions, apply the push end of an 8 oz. scale to the top of each push bar and push vertically downward. It should re-

quire 1 to 2-1/2 ozs. to start each push bar moving. When checking this tension, hold the location levers (Figure 24) away from the No. 1 and No. 2 push bars, the third-pulse bell crank (Figure 11) away from the No. 3 push bar, and the code discs (Figure 22) away from the No. 4 and No. 5 push bars.

(17) FUNCTION-BAR SPRINGS TENSION (Figure 26)

With the function cam sleeve in the stop position, hook a 32 oz. scale over the rear of each function bar just to the right of the spring and pull parallel to the spring. It should require 9 to 10 ozs. to start each function bar moving forward.

(18) PRINTING SHIELD ADJUSTMENT

Insert a piece of tape in the tape guide under the printing shield. See Figure 27 for location of parts. Position the printing shield by means of its mounting nut so that the bump on the underside of the shield and the ends of the two fingers of the shield touch the tape, and so that the following requirement is met: Hook an 8 oz. scale in the tape and pull in line with the tape. It should require not less than 1/2 oz. to pull the tape through the guide.

(19) FUNCTION-BAR RESET-CAM-FOLLOWER BACKSTOP SCREW ADJUSTMENT (Figure 28)

With the function cam sleeve in the stop position, there should be some clearance, not more than .015", between the bottom of the reset cam follower and the backstop screw. To adjust, position the backstop screw which is accessible from the under side of the typing unit and tighten the lock nut.

(20) FUNCTION-BAR RESET SCREW ADJUSTMENT (Figure 29)

With the selector and function cam sleeves in their stop positions and the No. 1 push bar selected by pushing it downward and hooking it under its selector lever, there should be .025" to .035" clearance between the front edge of the No. 1 push bar and the upper function bar. To adjust, position the function-bar reset screw (Figure 28) which is accessible from the rear of the front plate and tighten the lock nut.

(21) FUNCTION-BAR RESET-CAM-FOLLOWER SPRING TENSION (Figure 28)

With the function cam sleeve in the stop

position, unhook the function-bar reset-cam-follower spring from the bracket. It should require 3-1/2 to 5-1/2 ozs. to pull the spring to position length when an 8 oz. scale is hooked in the spring and pulled in line with it. Rehook the spring.

(22) SELECTOR-ARMATURE PIVOT PLATE ADJUSTMENT

With the selector armature held in its operated position (extension against its marking stop), the armature extension should be vertical as gauged by eye. To adjust, position the selector-armature pivot plate by means of its mounting screws. See Figure 30 for location of parts.

NOTE

If necessary, loosen the selector-magnet yoke mounting screws and push the magnet to its rearmost position.

(23) SELECTOR-MAGNET YOKE ADJUSTMENT (Figure 31)

With the selector armature locked in its operated position (extension against its marking stop) by the locking lever, there should be some clearance, not more than .004" between both cores of the magnet and the armature. To adjust, position the selector-magnet yoke by means of its mounting screws.

(24) SELECTOR-ARMATURE PIVOT CLAMP ADJUSTMENT

NOTE

In order to check this adjustment, it will be necessary to remake it.

Loosen the two selector-armature pivot clamp screws. While holding the selector armature in its unoperated position, (extension against its spacing stop) push the armature pivot clamp to where it just touches the armature extension and tighten the clamp screws. See Figure 31 for location of parts.

(25) SELECTOR-MAGNET-BRACKET ADJUSTING POST ADJUSTMENT (Figure 30)

(a) With each selector lever in turn on the point of its cam just before dropping off (when the locking lever just falls to a low part of its cam) and the armature held in its marking position, measure the clearance between the top of the blocking surface on each selector lever and the bottom of the ar-

mature extension. Note which lever has the least clearance.

(b) Then, with the locking lever on a high point of its cam and the armature extension opposite the locking lever wedge, measure the clearance between the bottom of the armature extension and the locking lever wedge. Note this clearance.

(c) Under the conditions specified in Paragraphs (a) and (b) there should be .012" to .018" clearance between the bottom of the armature extension and the selector lever or the locking-lever wedge, whichever has the least clearance.

(26) SELECTOR-CAM-SLEEVE STOP-LEVER SPRING TENSION (Figure 32)

With the selector-cam-sleeve stop lever on the high part of its cam, apply the push end of an 8 oz. scale to the top of the stop lever just behind the selector armature and push as nearly as possible vertically downward. It should require 1 to 2 ozs. to start the lever moving.

(27) SELECTOR-LEVER SPRING TENSION (Figure 30)

With the No. 1 selector lever on the high part of its cam and the No. 1 push bar held away from the selector lever, apply the push end of an 8 oz. scale to the top of the selector lever just in front of the selector armature and push vertically downward. It should require 1/2 to 1 oz. to start the selector lever moving. Check each of the other selector-lever springs for the same requirement.

(28) SELECTOR-ARMATURE LOCKING-LEVER SPRING TENSION (Figure 30)

With the selector-armature locking lever on a high part of its cam and the selector-armature extension held away from the stops on the locking lever, apply the push end of an 8 oz. scale to the top of the spacing stop on the locking lever and push as nearly as possible vertically downward. It should require 1/2 to 1 oz. to start the locking lever moving.

(29) SELECTOR-ARMATURE SPRING TENSION ADJUSTMENT (Figure 30)

With the start-stop lever (Figure 32) and the armature locking lever on the high part of their cams, hook an 8 oz. scale over the top of the armature extension at the spring

hole and pull in line with the spring. It should require 3-1/2 to 6 ozs.\* to start the selector armature moving. To adjust, position the armature-spring bracket by means of its mounting screw.

\*This requirement may be varied within the limits to meet range and bias requirements.

(30) PUSH-BAR STRIPPER-BAIL ECCENTRIC POST ADJUSTMENT (Figure 33)

With the push-bar stripper-bail cam follower on the high point of its cam, hold the function clutch driving pawl away from the ratchet wheel and rotate the main shaft until all of the selector levers are on the high part of their cams. Under this condition there should be .010" to .030" clearance between the end of each selector lever and its respective push bar. To adjust, position the eccentric post in the push-bar stripper-bail arm and tighten its lock nut.

(31) PUSH-BAR STRIPPER-BAIL SPRING TENSION (Figure 33)

With the function cam sleeve in the stop position, hook an 8 oz. scale over the slotted end of the push-bar stripper-bail eccentric post through the opening in the front plate and pull horizontally forward. It should require 1-1/2 to 3-1/2 ozs. to just start the eccentric post moving.

(32) REPLACE THE RACK-PAWL SLIDE, THE CENTRALIZER MECHANISM, THE RIBBON-GUIDE SPRING, THE RIBBON GUIDE, AND THE TYPE-SECTOR AS FOLLOWS: DO NOT HOOK THE CENTRALIZER SPRING ON THE RACK-PAWL POST.

(a) With the selector and function cam sleeves in their stop positions and the type-sector stop arm (Figure 22) in the center position, place the rack-pawl slide (Figure 11) on the mounting posts (making sure that its lower projections engage the third-pulse bell crank). Place both racks in their uppermost position as determined by the collars on the centralizer bail arm, and slide the centralizer mechanism onto the type-sector pinion (care must be taken that rack and gear teeth do not jam and that both racks are under the centralizer bail arm). Replace the mounting screws and posts, and tighten in place.

(b) Replace the ribbon guide (being careful not to distort the retainer) and tighten the ribbon-retainer mounting screws.

(33) CENTRALIZER RACKS ADJUSTMENT

(a) With the function cam sleeve rotated until the centralizer bail arm is in its uppermost position and the No. 4 and No. 5 push bars are selected (by pushing them downward and hooking them under their selector levers), the type-sector pinion should be free throughout its entire travel with a minimum amount of backlash between the pinion and the racks. As a check, place a screw driver against the inner edge of one of the racks and apply sufficient pressure to hold the rack in a fixed position and check the backlash of the type-sector pinion by rocking the type-sector. There should be some backlash, not more than 1/16", as measured at the face of the type-sector. Check the other rack in the same manner.

(b) To adjust, loosen the four rack-plate mounting screws and move the rack guide away from the racks. Position either the left or right rack guide so that its rack meets the above requirements and clamp the guide in place by its pair of mounting screws. Then position the other rack guide so that its rack meets the same requirements. See Figures 11 and 34 for location of parts.

(34) RIBBON GUIDE COMPRESSION SPRING TENSION

With the type-sector removed and the main shaft in the stop position, apply the push end of a 32 oz. scale to the top of the ribbon guide hub and push in line with the spring. It should require 11 to 16 ozs. to start the ribbon guide (Figure 1) moving toward the rear.

HOOK THE CENTRALIZER SPRING (FIGURE 11) ON THE RACK-PAWL SPRING POST.

(35) CENTRALIZER-BAIL ECCENTRIC STUD ADJUSTMENT (Figure 34)

With the function cam sleeve in the stop position, there should be some clearance, not more than .015", between the top of one rack and the collar on the centralizer-bail arm when the type-sector is rotated until the top of the other rack just touches the other collar on the centralizer bail arm. To adjust, position the centralizer-bail eccentric stud by means of its clamping screw.

(36) CENTRALIZER SPRING TENSION (Figure 11)

With the function cam sleeve in the stop position, hook a 32 oz. scale over the rack pawl spring post and pull downward as nearly

as possible in line with the spring. It should require 26 to 30 ozs. to start the rack pawl moving.

(37) THIRD-PULSE BELL CRANK ADJUSTMENT  
(Figure 11)

With the selector cam sleeve in the stop position and the No. 3 push bar selected by pushing it downward and hooking it under its selector lever, there should be some clearance, not more than .010", between the inner edge of the left centralizer rack and the rack pawl. To adjust, position the third-pulse bell-crank extension with respect to the bell crank by means of the clamping screw.

(38) THIRD-PULSE BELL-CRANK SPRING TENSION  
(Figure 11)

With the selector cam sleeve in the stop position and the centralizer spring unhooked from the rack pawl, hook an 8 oz. scale over the head of the clamping screw and pull horizontally to the right. It should require 2 to 4 ozs. to start the third pulse bell crank moving. Rehook the centralizer spring.

(39) PRINTING BAIL ADJUSTMENT (Figure 35)

The printing bail extension should line up with the center of the type-sector shaft (as gauged by eye) and the printing bail should have some side play, not over .006", at its bearings. To adjust, loosen the tape guide mounting screws so that it is free to move and position the printing bail collars by means of their set screws which are accessible from the rear of the typing unit.

(40) TAPE GUIDE ADJUSTMENT

There should be .012" to .020" clearance between the printing shield and the face of the characters M, O, and A (check all three) on the type-sector. To check this clearance, select each of the three characters and then hold the type-sector backward so that the characters are over the rear leaf of the printing shield and measure the clearance under this condition. The printing-bail extension should be free in its guide slot. See Figures 27 and 35 for location of parts. Tighten the tape guide mounting screws.

(41) PRINTING-BAIL SPRING TENSION (Figure 35)

With the function cam sleeve in the stop position and the typing unit lying on its left side, apply the push end of an 8 oz. scale to

the printing bail just above the spring and push parallel with the spring. It should require 1 to 2 ozs. to start the printing bail moving.

(42) TYPE-SECTOR-SHAFT STOP COLLAR ADJUSTMENT

With the selector cam sleeve in its stop position and the shift plate arm (Figure 37) in the LETTERS position, push the No. 3 and No. 5 push bars down and hook them under their selector levers. Slowly turn the function cam sleeve until the letter H is selected and the printing hammer is operated. Then hold the printing hammer against the face of the character. Under this condition, the letter H should align with the printing hammer with respect to the forward and rear edges of the printing hammer. To adjust, position the stop collar on the rear of the type-sector shaft by means of the extension lock nut. See Figure 24 for location of parts.

(43) TYPE-SECTOR RESET-BAIL SPRING TENSION (Figure 36)

With the centralizer-bail arm in its uppermost position and the two rear type-sector-shaft location levers tripped so that the stop collar is against the forward location lever, hook an 8 oz. scale under the bail at the spring hole and pull as nearly as possible vertically upward. It should require 1 to 2 ozs. to start the type-sector reset bail moving.

NOTE

It may be necessary to hold the stop collar backward out of the way of the bail in order to permit perceptible movement of the bail while checking this spring tension.

(44) TYPE-SECTOR-SHAFT PROPULSION SPRINGS TENSION

With the centralizer bail arm in its uppermost position and the location levers held away from the stop collar, apply the push end of an 8 oz. scale to the front end of the type-sector shaft and push in line with the shaft. It should require 5 to 6 ozs. to start the type-sector shaft moving toward the rear. See Figures 24 and 34 for location of parts.

(45) SHIFT-PLATE STOP BRACKET ADJUSTMENT

With the shift-plate arm in the LETTERS position, the letter H selected and the print-

ing hammer held against the face of the letter H, it should align with the printing hammer with respect to the left and right positions. To adjust, position the shift-plate stop bracket on its two mounting screws. See Figure 37 for location of parts.

(46) SHIFT-LATCH ECCENTRIC SCREW ADJUSTMENT (Figure 38)

The travel of the shift-latch extension should be equalized so that when the shift-plate arm is in the LETTERS or FIGURES position, the extension will have an equal bite on the shift-plate arm or extend beyond the front surface of it by equal amounts. To adjust, position the shift-latch eccentric screw and tighten its lock nut.

(47) SHIFT-LATCH SPRING TENSION (Figure 38)

Apply the push end of an 8 oz. scale horizontally to the front edge of the latch at the front edge of the latching finger. It should require a pressure of 1 to 2-1/2 ozs. to hold the front edge of the shift latch in line with the rear edge of the shift-plate arm.

(48) SHIFT-PLATE DETENT SPRING TENSION (Figure 38)

With the shift-plate arm in the LETTERS position, hook an 8 oz. scale to the detent spring just below its curved portion and pull horizontally forward. It should require 1 to 2 ozs. to start the spring moving.

(49) PRINTING-BAIL-LINK ECCENTRIC SHOULDER SCREW ADJUSTMENT

Set up the letter O combination (No. 4 and No. 5 push bars selected by pushing them downward and hooking them under their selector levers) and turn the main shaft until the printing cam follower is on the low part of its cam. Under these conditions, the face of the printing hammer should be in line with the upper surface of the tape guide as gauged by eye. (Push the type-sector toward the rear when checking.) To adjust, position the printing-bail-link eccentric shoulder screw by means of its lock nut. See Figure 14 for location of parts.

(50) PRINTING-BAIL-EXTENSION BACKSTOP ADJUSTMENT (Figure 35)

With the printing cam follower on the high part of its cam and the printing-bail extension held upward to take up the play of the eccentric shoulder screw in the slot of the

printing-bail link, there should be at least .020" clearance between the bottom edge of the printing-bail extension and its backstop. To adjust, position the printing-bail-extension backstop and tighten the mounting screws.

(51) PRINTING CAM-FOLLOWER SPRING TENSION (Figure 14)

With the printing cam follower on the high part of its cam, apply the push end of a 32 oz. scale to the cam follower at the point where the printing-bail link connects to the cam follower and push vertically downward. It should require 16 to 19 ozs. to start the printing cam follower moving.

(52) SUPPRESSOR-LEVER LATCH PLATE ADJUSTMENT (Figure 26)

With either the LETTERS, FIGURES, or BLANK function selected, (whichever causes the suppressor lever latches to overtravel the latching surface of the latch plate by the least amount) rotate the main shaft until the selected function bar is in its rearmost position. Under this condition, there should be .005" to .015" clearance between the rear vertical surface of the suppressor-lever latch plate and the latching surface of the two suppressor-lever latches. To adjust, position the suppressor-lever latch plate and tighten its two mounting screws.

(53) SUPPRESSOR-LEVER LATCH SPRING TENSION (Figure 14)

With the function cam sleeve in the stop position, apply the push end of an 8 oz. scale to each suppressor lever between the letters-figures and the line-feed function bars and push horizontally to the rear. It should require 1/4 to 1 oz. to start either the space suppressor lever or the print suppressor lever moving.

(54) SUPPRESSOR-LEVER GUIDE ADJUSTMENT (Figure 14)

With any character selected, rotate the main shaft and determine which of the two, the spacing push bar or the printing bail link, has the least clearance between its extension and its suppressor lever when the extensions which engage the suppressor levers are opposite the rear tip of their respective suppressor levers and when the play of the push bar and link is taken up in the direction that makes the clearance a minimum. Under these conditions there should be .010" to .020" clearance between the rear tip of a suppressor lever and

the spacing push bar extension or printing bail link extension, whichever has the least clearance. To adjust, position the suppressor lever guide by adding or removing shims between the guide and the front plate.

(55) SPACING CAM-FOLLOWER EXTENSION ADJUSTMENT (Figure 14)

With the spacing cam follower on the high point of its cam and the suppressor-lever latches held depressed by the extension on the space feed-pawl push bar, there should be .015" to .025" clearance between the upper surface of the suppressor-lever latches and the lower surface of the latch plate. To adjust, position the spacing cam-follower extension and tighten its two mounting screws.

(56) SPACING CAM-FOLLOWER SPRING TENSION (Figure 14)

With the spacing cam follower on the high point of its cam and the spacing push bar held downward away from the spacing cam follower, apply the push end of an 8 oz. scale to the top of the cam-follower extension in front of the cam follower and push vertically downward. It should require 1 to 2 ozs. to start the cam follower moving.

(57) SPACING-PAWL SPRING TENSION (Figure 39)

With the spacing cam follower on the high point of its cam, hook an 8 oz. scale to the spacing pawl just above a tooth on the ratchet and pull horizontally to the left as viewed from the front of the printer. It should require 2 to 3 ozs. to start the spacing pawl moving.

(58) SPACING PUSH-BAR SPRING TENSION

With the spacing pawl spring unhooked and the spacing cam follower on the low part of its cam, apply the push end of an 8 oz. scale to the top of the spacing push bar just to the left of the spacing cam-follower extension and push vertically downward. It should require 2 to 3 ozs. to start the spacing push bar moving. Rehook the spacing pawl spring. See Figures 14 and 39 for location of parts.

(59) SPACING DETENT BRACKET ADJUSTMENT (Figure 39)

With the spacing cam follower on the high part of its cam, there should be .004" to .010" clearance between the lower end of the spacing pawl and the face of the next tooth

on the ratchet wheel. To adjust, position the spacing detent bracket on its two mounting screws.

(60) SPACING DETENT SPRING TENSION (Figure 39)

With the spacing cam follower on the high point of its cam, hook an 8 oz. scale to the roller stud of the spacing detent and pull approximately at right angles to the detent. It should require 6-1/2 to 7-1/2 ozs. to start the spacing detent moving.

(61) SPACING CAM-FOLLOWER UP-STOP SCREW ADJUSTMENT

NOTE

This adjustment applies only to typing units equipped with a spacing cam-follower up-stop screw which is located directly above the forward end of the spacing cam follower.

With the spacing cam follower against its up-stop screw, the end of the spacing pawl should clear the shoulder of the ratchet wheel tooth immediately ahead by .030" to .060". See Figures 14 and 39 for location of parts. To adjust, position the spacing cam-follower up-stop screw and tighten its lock nut.

(62) TAPE-PRESSURE-ROLLER ARM ADJUSTMENT

The tape-pressure-roller arm should be free on its bearing and should have some end play, not more than .004". To adjust, position the collar by means of its set screws, keeping the set screw positioned vertically downward. See Figure 40 for location of parts.

(63) TAPE-PRESSURE-ROLLER ARM SPRING TENSION (Figure 40)

With the tape pressure roller resting on the feed roll, hook a 32 oz. scale to the nut in front of the pressure roller and pull parallel to the pressure-roller arm spring. It should require 10 to 12 ozs. to start the pressure roller moving away from the feed roll.

(64) RIBBON-SPOOL SHAFT PRESSURE ADJUSTMENT (Figure 41)

With the ribbon-feed pawl against the left ratchet wheel, hook an 8 oz. scale over the pin in the right ratchet wheel and pull horizontally at right angles to a line through the center of the pin and the center of the ribbon-spool shaft. It should require 3-1/2



to 5 ozs. to start the right ratchet wheel moving. To adjust, position the right spool-shaft adjusting nuts. Adjust the left ribbon-spool shaft in the same manner, but with the ribbon-feed pawl against the right ratchet wheel.

(65) RIBBON OVERCENTERING SPRING TENSION  
(Figure 41)

With the ribbon mechanism removed from the typing unit and the ribbon-feed pawl against one of the ratchet wheels, hook an 8 oz. scale under the slide clamping screw and pull vertically upward. It should require 4 to 6 ozs. to start the ribbon-feed-pawl slide moving.

REPLACE THE RIBBON MECHANISM ON THE  
TYPING UNIT.

(66) RIBBON-FEED-PAWL SLIDE ADJUSTMENT  
(Figure 41)

With the function cam sleeve in the stop position, there should be some clearance, not more than .010", between the bottom of the slot in the ribbon-feed-pawl slide and the centralizer-bail arm. To adjust, position the ribbon-feed-pawl slide and tighten its clamping screw.

REPLACE THE RIBBON.

(67) RIBBON-REVERSE-LEVER DETENT SPRING  
TENSION (Figure 41)

Hook an 8 oz. scale to the ribbon-reverse-lever detent at the spring hole and pull horizontally to the left. It should require 1 to 2 ozs. to start the detent moving.

(68) TYPE-SECTOR RESET-BAIL ADJUSTING  
SCREW ADJUSTMENT

With the function cam sleeve in the stop position and a piece of tape with printed characters inserted in the tape chute between the tape pressure roller and the feed roll, the front edge of the ribbon should be approximately in line with the top of the printed characters and the type-sector shaft should have some end play. To adjust, position the type-sector reset-bail adjusting screw (Figure 36) and tighten its lock nut. Recheck the CENTRALIZER-BAIL-ARM ECCENTRIC STUD ADJUSTMENT.

NOTE

With the letter A selected and the main shaft rotated until the centralizer-bail arm is in its uppermost

position, the type-sector-shaft stop collar should be against its stationary stop (Figure 24) on the location lever guide and there should be some clearance between the stop collar and the type-sector reset bail (Figure 36). If these requirements are not met, refine the TYPE-SECTOR-SHAFT STOP COLLAR ADJUSTMENT, the CENTRALIZER-BAIL ECCENTRIC STUD ADJUSTMENT, and the TYPE-SECTOR RESET-BAIL ADJUSTING SCREW ADJUSTMENT.

(69) SELECTOR CLUTCH TORQUE (Figure 42)

With the main shaft running at least 10 minutes, hook a 32 oz. scale over the tip of the projection on the stop disc at a right angle to the radius. It should require 18 to 22 ozs. to hold the stop disc stationary. Adjust by means of the clutch spring adjusting nuts.

(70) MOTOR GOVERNOR BRUSH SPRING ADJUSTMENT

Each brush should rest against the governor ring with a pressure of 2-1/2 to 3-1/2 ozs. Adjust by bending the brush springs.

b. END-OF-LINE INDICATOR MECHANISM

NOTE

These adjustments apply only to typing units equipped with end-of-line indicator mechanism.

(1) CHECK-PAWL ECCENTRIC ADJUSTMENT (Figure 43)

With the spacing cam follower (Figure 14) on the highest point of its cam, and the feed pawl engaging the ratchet wheel, there should be .006" to .015" clearance between the lower end of the check pawl and the radial surface of a tooth on the ratchet wheel. To adjust, position the check-pawl eccentric. The heavy side of the eccentric should be toward the ratchet wheel.

(2) FEED-PAWL LEVER ADJUSTMENT (Figure 44)

With the spacing cam follower (Figure 14) on the low part of its cam and the ratchet wheel held by the check pawl, there should be .006" to .015" clearance between the radial surface of a ratchet wheel tooth and the feeding face of the feed pawl. To adjust, position the feed-pawl-lever eccentric.

(3) STOP-PAWL ECCENTRIC ADJUSTMENT (Figure 44)

With the ratchet wheel in its fully returned position and the stop pawl held against the ratchet-wheel stop arm, there should be some clearance, not over .006", between the stop pawl and the stop-pawl eccentric. To adjust, position the stop-pawl eccentric.

(4) RELEASE-PAWL-LEVER ECCENTRIC ADJUSTMENT (Figure 44)

With the carriage-return function bar in its reset position and the check pawl engaging the ratchet wheel, there should be some, not more than .010" clearance between the pin on the release pawl and the upward extension on the check pawl. To adjust, position the release-pawl-lever eccentric.

(5) RELEASE-PAWL LATCH ADJUSTMENT (Figures 44 and 45)

(a) With the carriage return function bar in its fully operated position and the ratchet wheel held rotated so that its stop arm is away from the stop pawl, there should be .006" to .015" clearance between the rear surface of the latch extension and the shoulder on the release pawl.

(b) With the carriage return function bar in its unoperated position and the ratchet-wheel stop arm against the stop pawl, the horizontal extension of the release pawl should clear the release-pawl latch by .004" to .010".

(c) Adjust for both requirements simultaneously by positioning the release-pawl latch.

(6) RATCHET RETURN SPRING ADJUSTMENT

Hold the contact spring away from the cam. Hold the ratchet-wheel stop pawl in its downward position. Hold the feed pawl and check pawl away from the ratchet wheel. With the ratchet wheel in its returned position, hook an 8 oz. scale over a tooth on the ratchet wheel. It should require a pull of 1 to 1-1/2 ozs. to start the ratchet wheel moving away from the stop pawl. To adjust, loosen the spring drum nut at the inner end of the ratchet-wheel shaft, rotate the drum in the mounting plate, and tighten the nut. See Figures 44 and 45 for location of parts.

(7) CONTACT ADJUSTMENTS (Figure 45)

(a) Hook an 8 oz. scale over the top of the longer contact-spring insulator and pull horizontally to the left. It should require a pull of 1/4 to 1 ozs. to move the insulator away from the low surface of the con-

tact cam. Adjust by bending the longer contact spring.

(b) With the longer contact spring against the low surface of the cam, the contact gap should be .015" to .030". Adjust by bending the shorter contact spring and stiffener.

(c) Hook an 8 oz. scale over the top of the shorter contact spring. It should require a pull of 1-1/2 to 3 ozs. to move the spring away from the upper end of the stiffener. Adjust by bending the shorter contact spring. Recheck (b).

(8) RELEASE PAWL SPRING TENSION (Figure 44)

With the carriage return function bar in its unoperated position apply the push end of an 8 oz. scale to the release pawl lever just above the carriage return function bar and push toward the left. Hold off the check pawl. It should require 3/4 to 1-1/4 ozs. to move the release pawl lever away from its eccentric.

(9) STOP PAWL SPRING TENSION (Figure 44)

With the stop pawl in its downward position, unhook the spring from its spring post and hook an 8 oz. scale in the spring eye. It should require a pull of 3/4 to 1-1/4 ozs. to extend the spring to its working length.

(10) CHECK PAWL SPRING TENSION (Figure 44)

With the function cam sleeve in its stop position and the ratchet wheel held by the feed pawl, hook an 8 oz. scale under the check pawl at the spring hole and pull upward. It should require a pull of 1-1/4 to 2 ozs. to start the check pawl moving away from the ratchet wheel.

(11) RELEASE LEVER SPRING TENSION (Figure 44)

Rotate the ratchet wheel so that its stop arm is away from the release lever. Apply an 8 oz. push scale to the release lever just above the spring and push toward the left. It should require a pressure of 1 to 2 ozs. to start the release lever moving.

(12) FEED PAWL SPRING TENSION (Figure 44)

With the ratchet wheel held by the check pawl, apply an 8 oz. scale to the feed pawl just above the spring and push at a right angle to the pawl. It should require a pressure of 1/4 to 1 oz. to start the pawl moving.

(13) CONTACT CAM ADJUSTMENT (Figure 45)

Position the cam by means of its set screw so the contacts close on the sixty-sixth space following carriage return.

### 3. KEYBOARD UNIT

#### a. ADJUSTING PROCEDURE

##### (1) RATCHET WHEEL SLEEVE END PLAY

The ratchet-wheel sleeve should have some end play, not more than .004". To adjust, add or remove shims between the transmitting gear and the rear bearing bracket. See Figure 2 for location of parts.

##### (2) LOCKING LEVERS ADJUSTMENT (Figure 5)

(a) With the transmitting cam sleeve in the stop position and the locking levers in the locking position, the following conditions should be met:

1. The locking levers should clear the ends of the contact levers by .005" to .010". Check each lever.

2. With the side play in the locking levers and the contact levers taken up in opposite directions, the locking levers should engage the contact levers by at least half their thickness. Make certain that the locking levers do not bind at their lower ends where they engage the code bars.

(b) To adjust, position the locking lever guide on its mounting screws.

##### (3) LOCKING LOOP SPRING TENSION

Select the BLANK combination and rotate the transmitting cam sleeve until the locking loop cam follower is resting on the low part of its cam. Hook an 8 oz. scale under the spring arm and pull vertically upward. It should require 2-1/2 to 3-1/2 ozs. to start the locking loop moving. See Figures 2 and 4 for location of parts.

##### (4) LOCKING LOOP BLADE ADJUSTMENT

With the transmitting cam sleeve in stop position, the edge of the locking loop blade should clear the points of the blocking levers by .008" to .015". The clearance at No. 1 and No. 5 levers should be equal within .005". Adjust by means of the locking loop blade mounting screws.

##### (5) TRANSMITTING CONTACTS GAP ADJUSTMENT (Figure 4)

With any contact lever on the high part of its cam, the contact gap should be \*.020" to .025". To adjust, bend the shorter contact springs.

\*For start-stop contact, the gap may be .015" to .025".

##### (6) CONTACT SPRING PRESSURE (Figure 46)

With any contact lever on the low part of its cam, apply the push end of an 8 oz. scale to the contact spring just above the contact point. It should require a pressure of 4-1/2 to 5-1/2 ozs. to open the contact. To adjust, bend the longer contact springs. Recheck the contact gap adjustment.

##### (7) RELEASE-PAWL STOP SCREW ADJUSTMENT (Figure 5)

The driving pawl should overlap the end of the release pawl by .025" to .045". Adjust the release-pawl stop screw to meet this requirement.

##### (8) TRIP PAWL ADJUSTMENT (Figure 5)

With the clutch held disengaged by the release pawl there should be a clearance of .065" to .095" between the shoulder on the trip pawl and the release pawl. Adjust the trip pawl by means of the pivot stud. Try each key lever and space bar by depressing it slowly to ascertain that the clutch trips for each operation. Refine the adjustment if necessary to meet this condition.

##### (9) TRIP-PAWL SPRING TENSION (Figure 5)

Rotate the transmitting cam sleeve to the stop position. Hook an 8 oz. scale to the spring arm of the trip pawl at the spring hole and pull in line with the spring. It should require from 1 to 2 ozs. to start the trip pawl moving.

##### (10) SELECTOR-BAR ROLLER BRACKETS ADJUSTMENT (Figure 5)

There should be a clearance of .040" to .060" between the underside of the top plate and the upper surface of the selector bar roller brackets. This clearance should be equal from front to rear on both sides of the unit within .005". To adjust, position both right and left selector bar guide roller brackets and tighten the mounting screws.

##### (11) CLUTCH PAWLS SPRING TENSION

Rotate the transmitting cam sleeve to where the blocking and driving springs are in a horizontal position above the ratchet wheel. Hook an 8 oz. scale over the pawl at the spring hole and pull horizontally in line with the spring. It should require 1-3/4 to 2-1/2 ozs. to start the pawl moving. Check both pawls. When checking the driving pawl spring hold off the blocking pawl. See Figure 5 for location of parts.

(12) REPEAT SPACE ROD BRACKET ADJUSTMENT

The release pawl should clear the end of the driving pawl by .010" to .030" when the space bar is held depressed and the trip pawl is held away from the release pawl. Check by depressing each end of the space bar separately. To adjust, bend the repeat space rod bracket. See Figure 5 for location of parts.

(13) KEY-LEVER SPRING TENSION ADJUSTMENT  
(Figure 47)

The openings between the ends of all key-lever springs, except the spacer key-lever

spring, should measure 1-3/16". The spacer key-lever springs should measure 1-15/16" across the opening between the ends. To adjust, bend the springs.

(14) UNIVERSAL-BAR SPRING TENSION (Figure 5)

Hook an 8 oz. scale over the universal-bar spring post and pull in line with the spring. It should require 1 to 2 ozs. to start the bar moving.

(15) TYPING UNIT POSITION ADJUSTMENT

Place the typing unit on the keyboard. With the typing unit mounting screws in place but not tightened, hold the typing unit back against the locating posts in the base and position the typing unit to right or left to provide perceptible backlash between the transmitting shaft gear and its mating gear. Tighten the typing unit mounting screws. Position the locating eccentric (Figure 2) at the right side of the typing unit so that it is against the typing unit frame.

SECTION IV

LUBRICATION

1. GENERAL

a. For parts of the Model 31 printer other than ball bearings use KS-7470 oil and KS-7471 grease.

b. Use DC 33 bearing grease supplied by Dow Corning Corporation, Midland, Michigan for lubricating the ball bearings of the vertical shaft and the dynamotor.

c. For operation at temperatures below 0 degrees Centigrade the KS-7470 oil and KS-7471 grease should be thinned by adding an equal quantity of kerosene. The DC 33 grease does not require thinning at low temperatures.

d. The motor bearings should be inspected for lubrication at intervals of 1000 hours of operation and relubricated if necessary. Coat the ball bearings with grease. Do not pack the bearings. The remainder of the machine should be lubricated at intervals of 275 hours of operation.

2. TYPING UNIT

a. Unless otherwise specified one or two drops of oil at each of the locations indicated will be sufficient. Use oil at all of the locations listed below except where the use of grease is specified.

(1) All gears and pinions - light coating of KS-7471 grease.

(2) Cam surfaces of selector and function cam sleeves - light coating of KS-7471 grease.

(3) Main shaft bearings - oil holes.

(4) Selector cam sleeve - at ends.

(5) Friction-clutch felt washers - spread the metal discs and saturate washers.

(6) Function cam sleeve - at ends.

(7) Function clutch - ratchet wheel and pawls.

(8) All cam followers and connecting levers - at pivot points and at engaging surfaces.

(9) Selector clutch lever on range finder - bearing, stop end, cam follower end.

(10) Selector magnet armature extension - at pivot points - 1 drop, at lock lever.

(11) Printing bail - bearings - guide.

(12) Printing bail link - shoulder screws.

(13) Push bar stripper bail - bearing - eccentric post.

(14) Reset cam-follower backstop screw - top of screw.

(15) Push bars - shoulder - guides - lower ends of bars.

(16) Type sector shaft location levers - bearings - guides - stop surfaces.

(17) Third pulse bell crank - bearing - at point of contact with push bar.

(18) Rack-pawl slide - slots - at point of contact with third pulse bell crank.

(19) Type sector racks - top of racks - between plates.

(20) Rack pawl - top of pawl - spring post - teeth.

(21) Rack-pawl push rod - both ends.

(22) Type sector stop arm - bearing - gear - slide - surfaces - points of contact with code discs.

(23) Ribbon guide - bearing.

(24) Type sector shaft - at both ends of bearing - at spring yoke.

(25) Function-bar reset bail - pivots - at point of contact with reset adjusting screw.

(26) Function bars - pivots - guides - points of contact with reset bail and push bars.

(27) Type sector reset bail - pivots.

- (28) Centralizer bail - bearings - eccentric stud - at ribbon slide - at point of contact with type-sector reset-bail adjusting screw.
- (29) Shift latch - bearing - latching surfaces.
- (30) Suppressor levers - shoulder screw - guide - latch surface.
- (31) Suppressor-lever latches - pivots - latching surfaces - at point of contact with space-link extension.
- (32) Space push bar - slots - point of contact with cam follower.
- (33) Spacing pawl - pivot.
- (34) Spacing ratchet wheel - bearing sleeve oil hole - teeth.
- (35) Spacing detent - pivot - roller.
- (36) Tape pressure roller arm - pivots.
- (37) Tape pressure roller - bearing.
- (38) Ribbon-feed ratchet wheels - bearing - teeth
- (39) Inner slide - bottom of slot.
- (40) Outer slide - guides - stud.
- (41) Feed pawl - pivot - retaining strap.
- (42) Check pawl - pivot - points of contact with feed pawl and ratchet wheels.
- (43) Reverse lever - pivot - points of contact with feed pawl.
- (44) Reverse lever detent - pivot - detent point.
- (45) Code discs - bearing - guides - points of contact with type sector stop arm.
- (46) Letters-figures shift plate - bearing - points of contact with latch.
- (47) Apply a drop of oil to both hooks of each spring.
- (48) Ribbon guide roller - bearing.
- (49) Vertical shaft ball bearings - DC 33 grease.

## 3. END-OF-LINE INDICATOR

- a. Contact cam - thin film KS-7471 grease.
- b. Apply one or two drops of oil at the following locations:
  - (1) Ratchet wheel shaft - inner and outer ends.
  - (2) Ratchet wheel teeth.
  - (3) Check pawl - bearing, upper end, lower end.
  - (4) Feed pawl - bearing, teeth.
  - (5) Feed pawl lever - bearing.
  - (6) Stop pawl - bearing, point, at eccentric.
  - (7) Release lever - bearing, lower end, front end.
  - (8) Release pawl lever - bearing, pawl pivot.
  - (9) Release pawl latch - latching edge.
  - (10) All helical springs - both hooks.

## 4. KEYBOARD

- a. LUBRICATION ON BOTTOM SIDE OF KEYBOARD - with front strap assembly removed.

- (1) Selector bars - guide slots, rollers, at points of contact with key levers.
- (2) Universal bar - guide slots and rollers.
- (3) Release lever - at universal-bar stud.
- (4) Key levers on key lever shafts - at front and rear guides.
- (5) Locking levers - at selector bar studs and between levers and bars.

- (6) Repeat space rod - both ends.
- (7) Repeat space link - lower end.

- b. LUBRICATION ON TOP SIDE OF KEYBOARD

- (1) Keyboard shaft - front and rear bearings - fill oil holes in casting.
- (2) Transmitting clutch - both pawls and ratchet.

(3) Cams - apply a light film of KS-7471 grease to the surfaces of all cams and oil felt rings between cams.

(4) Locking loop - bearings.

(5) Contact lever bearings.

(6) Locking levers in guide - upper ends, locking points.

(7) Release lever at bearings.

(8) Clutch pawl and release pawl - bearings and operating surfaces.

(9) Keyboard gear - grease (KS-7471).

(10) Repeat space link - at stud in release pawl.

(11) All helical springs - both hooks.

SECTION V

PROBABLE TROUBLES AND POSSIBLE CAUSES

1. Errors in Selection:

Incorrect motor speed.  
Incorrect signal-line current.  
Incorrect range finder setting.  
Incorrect selector adjustments.  
Incorrect friction clutch torque.

2. Defective Printing:

Worn printing hammer.  
Incorrect alignment of type sector with  
printing hammer.  
Worn ribbon with rolled edge.  
Damaged or incorrectly adjusted printing  
shield.

3. Motor Speed Failure:

Governor contacts dirty or pitted.  
Governor brushes and rings dirty.  
Speed-control vacuum tube defective.



SECTION VI

SPARE PARTS

The list of parts in the 106949 spare

parts kit are shown on

Pages 6-1 to 6-3 inclusive.

(B-200)

106949 SPARE PARTS KIT FOR  
MODEL 31 TAPE PRINTER

<u>Quantity</u>	<u>Part Number</u>	<u>Description</u>
2	33-29	Screw 6-40 Shoulder Fil.
4	33-86	Screw 4-40 x 1/8 Fil.
4	33-110	Screw 4-40 x 3/16 Fil.
2	34-1	Nut 1/4-32 Hex.
2	34-11	Nut 2-56 Hex.
1	35-68	Spring
3	35-70	Spring
5	35-89	Spring
10	103-27	Washer
2	M-243	Magnet Coil (Assem.) 950 Ohms
10	1026	Screw 6-40 x 3/8 Fil.
2	1086	Screw 4-40 x 3/8 Set
2	1159	Screw 4-40 x 3/8 Fil.
2	1160	Screw 6-40 x 5/16 Fil.
2	1161	Screw 6-40 x 1/4 Fil.
4	1162	Screw 6-40 x 1/4 Fil.
2	1163	Screw 4-40 x 3/16 Fil.
4	1168	Screw 4-40 x 5/16 Fil.
2	1176	Screw 6-40 x 3/16 Fil.
2	1208	Screw 10-32 x 5/8 Fil.
20	2191	Lock Washer
2	2415	Spring
4	2565	Spring
1	2605	Spring
10	2669	Lock Washer
1	2836	Spring
2	3595	Nut 1/4-32 Hex.
10	3598	Nut 6-40 Hex.
5	3599	Nut 4-40 Hex.
2	3606	Nut 6-40 Hex.
20	3640	Lock Washer
1	4708	Spring
10	7002	Washer
2	7603	Spring
6	8543	Screw 6-40 x 1/4 Fil.
5	31636	Spring
2	33765	Washer
2	36351	Spring
2	41974	Spring
1	49420	Spring
1	55090	Spring
3	72450	Spring
1	72514	Spring
1	76299	Spring
1	76379	Spring
5	76800	Spring
4	80342	Screw 6-40 x 23/64 Hex.
2	81731	Spring
2	82392	Shim
1	82860	Spring
2	82999	Spring

## Section VI

(B-200)

<u>Quantity</u>	<u>Part No.</u>	<u>Description</u>
1	84226	Spring
2	85762	Washer
2	86078	Wick
2	86742	Nut 4-40 Hex.
1	86772	Screw 6-40 Eccentric
4	89407	Cotter Pin
1	90615	Spring
14	93050	Wick
2	93191	Screw 4-40 x 5/16 Flat
1	109004	Code Disc - Front
1	109006	Code Disc - Center
2	109007	Slide - Rack Pawl
1	109008	Code Disc - Rear
2	109017	Post
1	109019	Shaft
1	109021	Push Bar No. 1
1	109023	Push Bar No. 2
1	109025	Push Bar No. 3
1	109027	Push Bar No. 4
1	109029	Push Bar No. 5
2	109032	Location Levers - No. 1 and 2
1	109034	Screw 4-40 Shoulder
1	109035	Common Location Lever (Assem.)
1	109038	Post
1	109039	Post
1	109041	Shaft
1	109042	Reset Bail
1	109045	Arm - Centralizer
1	109056	Print Suppressor (Assem.)
1	109063	Space Suppressor (Assem.)
1	109078	Lever - Shift Plate Lock
1	109080	Spring
1	109086	Bracket
2	109088	Bracket
1	109091	Wick
1	109092	Wick
1	109096	Roller
1	109097	Detent (Assem.)
2	109103	Bushing
1	109112	Shield-Ribbon
2	109114	Post - with Pin
1	109115	Bail
4	109116	Lever - Function
1	109117	Bell Crank - No. 3
1	109119	Post
1	109120	Type Sector Stop Arm (Assem.)
1	109125	Arm - Type Sector
1	109126	Rack Pawl - with Post
2	109128	Rack
2	109129	Post
1	109143	Bushing
1	109146	Ribbon Reverse Lever (Assem.)
1	109150	Pawl - with Post
2	109152	Screw 4-40 x 11/64 Fil.
1	109153	Slide (Assem.) - Outer
1	109155	Slide - Inner
1	109156	Feed Pawl - with Post
1	109157	Strap - with Posts
2	109160	Nut 4-40 Hex.

(B-200)

<u>Quantity</u>	<u>Part No.</u>	<u>Description</u>
1	109161	Ratchet (Assem.) - Right
1	109164	Ratchet (Assem.) - Left
2	109165	Washer - Spring
1	109166	Detent
1	109178	Lever - Selector
1	109183	Lever - Clutch
1	109184	Print Cam Follower - with Hub
1	109186	Space Cam Follower - with Hub
2	109195	Clamp - Bearing
1	109199	Lever - with Hub
1	109201	Screw 6-40 Shoulder Fil.
1	109204	Shaft
1	109213	Lever - Print
1	109215	Link - Print Lever
10	109233	Print Hammer (Assem.)
1	109251	Disc
1	109256	Bearing - Left
1	109259	Bearing - Right
1	109271	Clutch - Driving
1	109287	Drive Pawl (Assem.)
1	109290	Pawl - Blocking
1	109297	Stud
1	109364	Bail
1	109365	Post - Eccentric
1	109631	Spring
1	109659	Post
1	109662	Screw 6-40 Shoulder - Eccentric
1	109666	Hub
1	109669	Disc - Cam Sleeve
6	109670	Disc - Friction
1	109671	Disc - Cam Sleeve
1	109674	Wearing Strip
1	109675	Spring
1	109683	Function Reset Arm (Assem.)
1	109943	Finger - Adjusting
5	109987	Shim
1	116409	Gear 47T
1	116410	Pinion 11T
2	116411	Amplifier Tube
1	116420	Cam Sleeve (Assem.)
1	116425	Cam Sleeve (Assem.)
1	116429	Shaft - with Clutch
1	116436	Selector Lever No. 1
1	116437	Selector Lever No. 2
3	116438	Selector Lever Nos. 3-4-5
1	116439	Lever - Lock
1	116441	Lever - with Extension
1	116442	Armature Extension
2	116527	Governor Brush
2	116628	Type Sector - 31 Type
4	116698	Lamp
2	116699	Lamp - Neon

SECTION VII

W I R I N G D I A G R A M

NO.	NOTES												
1.	<p>WIRE COLOR CODE MAY BE SOLID COLOR OR TRACERS IN WHITE WIRE</p> <table border="0"> <tr> <td>W WHITE</td> <td>S SLATE</td> </tr> <tr> <td>R RED</td> <td>BR BROWN</td> </tr> <tr> <td>G GREEN</td> <td>BL BLUE</td> </tr> <tr> <td>Y YELLOW</td> <td>BK BLACK</td> </tr> <tr> <td>O ORANGE</td> <td></td> </tr> <tr> <td>P PURPLE- RED AND BLUE TRACERS</td> <td></td> </tr> </table>	W WHITE	S SLATE	R RED	BR BROWN	G GREEN	BL BLUE	Y YELLOW	BK BLACK	O ORANGE		P PURPLE- RED AND BLUE TRACERS	
W WHITE	S SLATE												
R RED	BR BROWN												
G GREEN	BL BLUE												
Y YELLOW	BK BLACK												
O ORANGE													
P PURPLE- RED AND BLUE TRACERS													
2.	<p>—X— DENOTES SPLICE &amp; TAPE WIRE.</p>												
3.	<p>ASSOCIATED CABLES</p> <table border="0"> <tr> <td>—————</td> <td>BASE LINE</td> </tr> <tr> <td>- - - - -</td> <td>BASE POWER</td> </tr> <tr> <td>- - - - -</td> <td>MOTOR LEADS</td> </tr> </table>	—————	BASE LINE	- - - - -	BASE POWER	- - - - -	MOTOR LEADS						
—————	BASE LINE												
- - - - -	BASE POWER												
- - - - -	MOTOR LEADS												

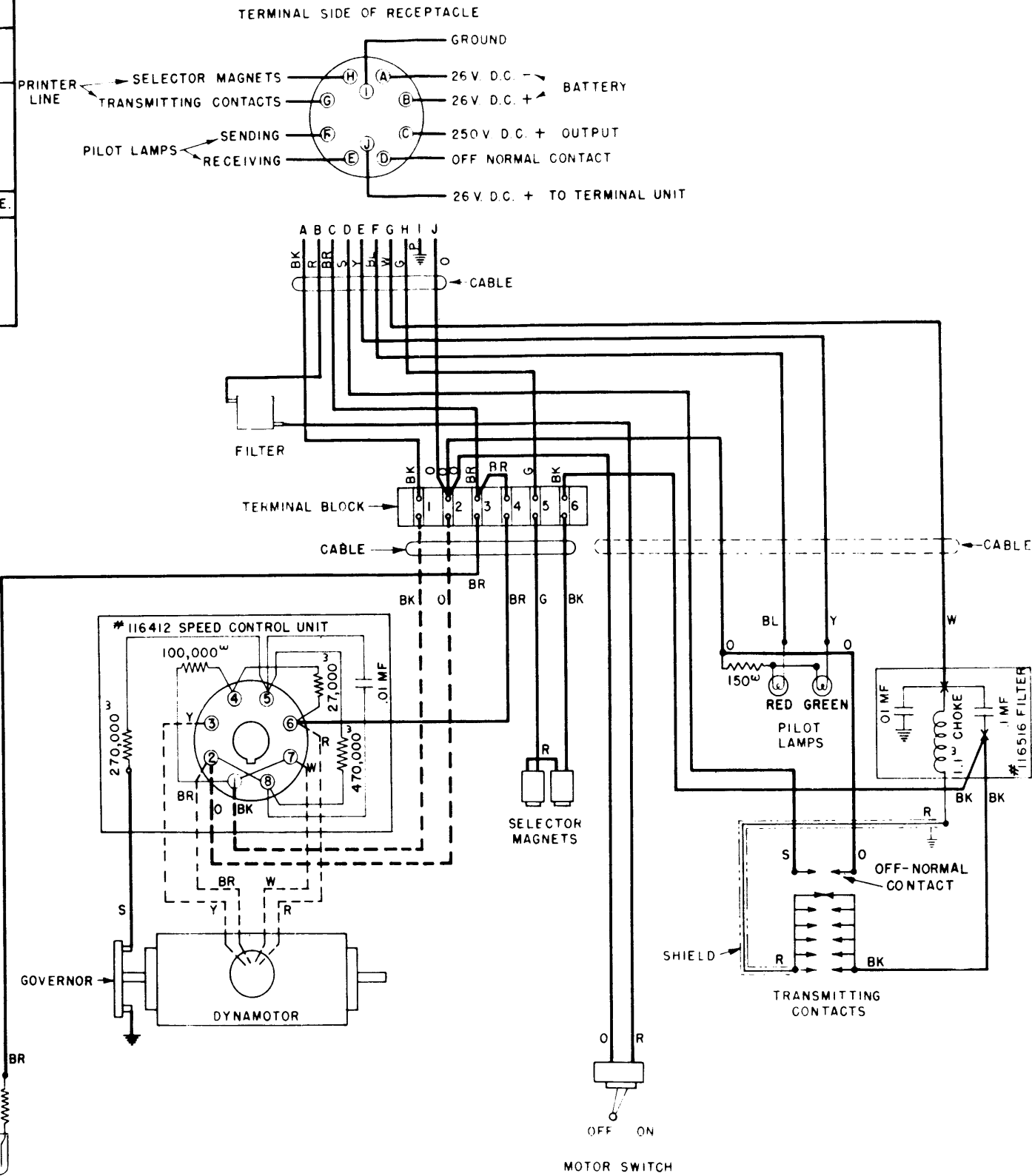

<p><b>WD-2487</b> 3-26-47</p>	
<p>WIRING DIAGRAM 31-TYPE PRINTER</p>	
<p>DRAWN: H.T.G.</p>	<p>APPROVED:</p>
<p>ENG'R'D: <i>HR.</i></p>	<p><i>FR.</i></p>
<p>FILE NO.: 1-30.87AA</p>	
<p><b>TELETYPE CORPORATION</b></p>	

SECTION VIII

Figures referred to in  
text of Sections I, II, and III

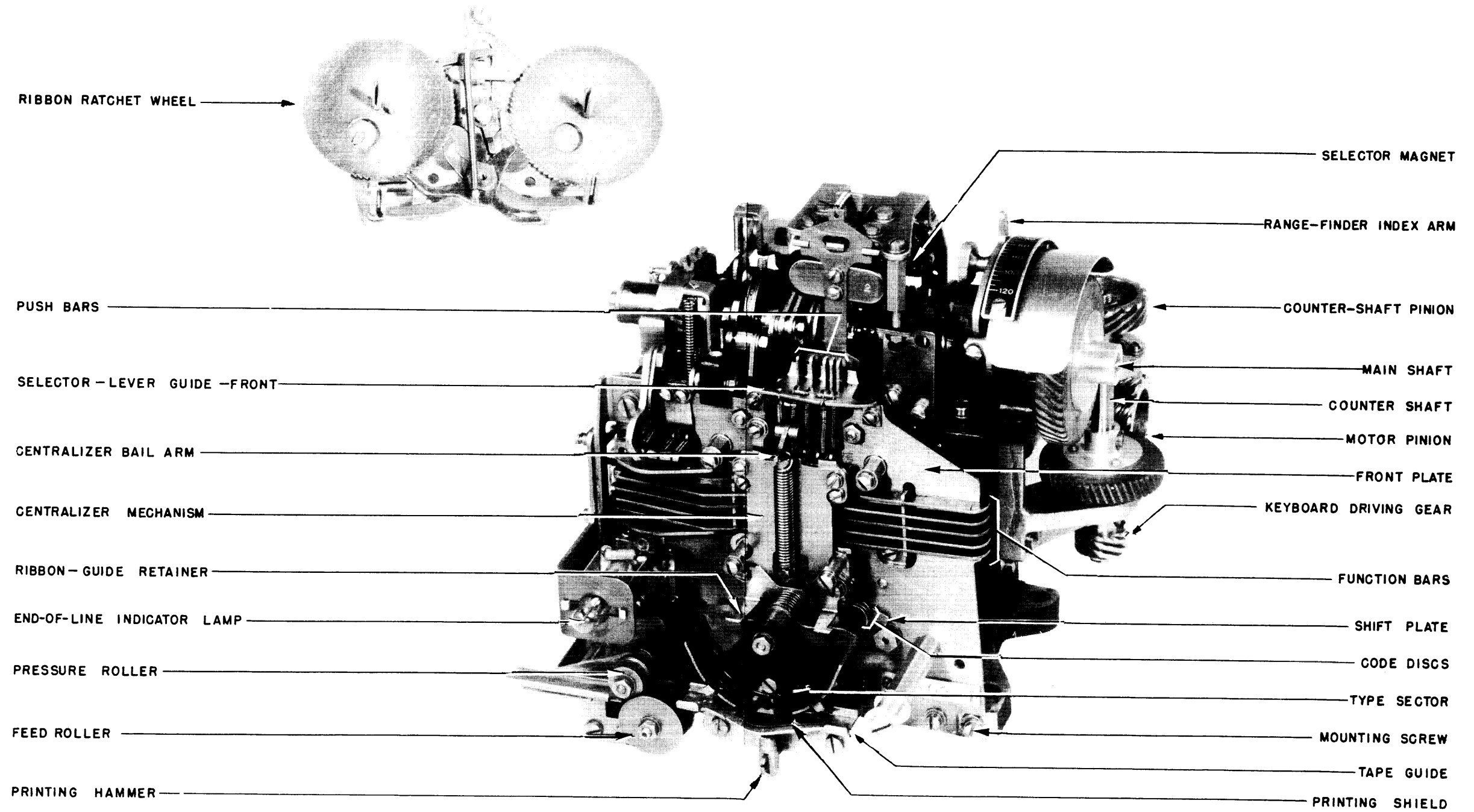

TYPING UNIT WITH RIBBON MECHANISM REMOVED

FIGURE 1



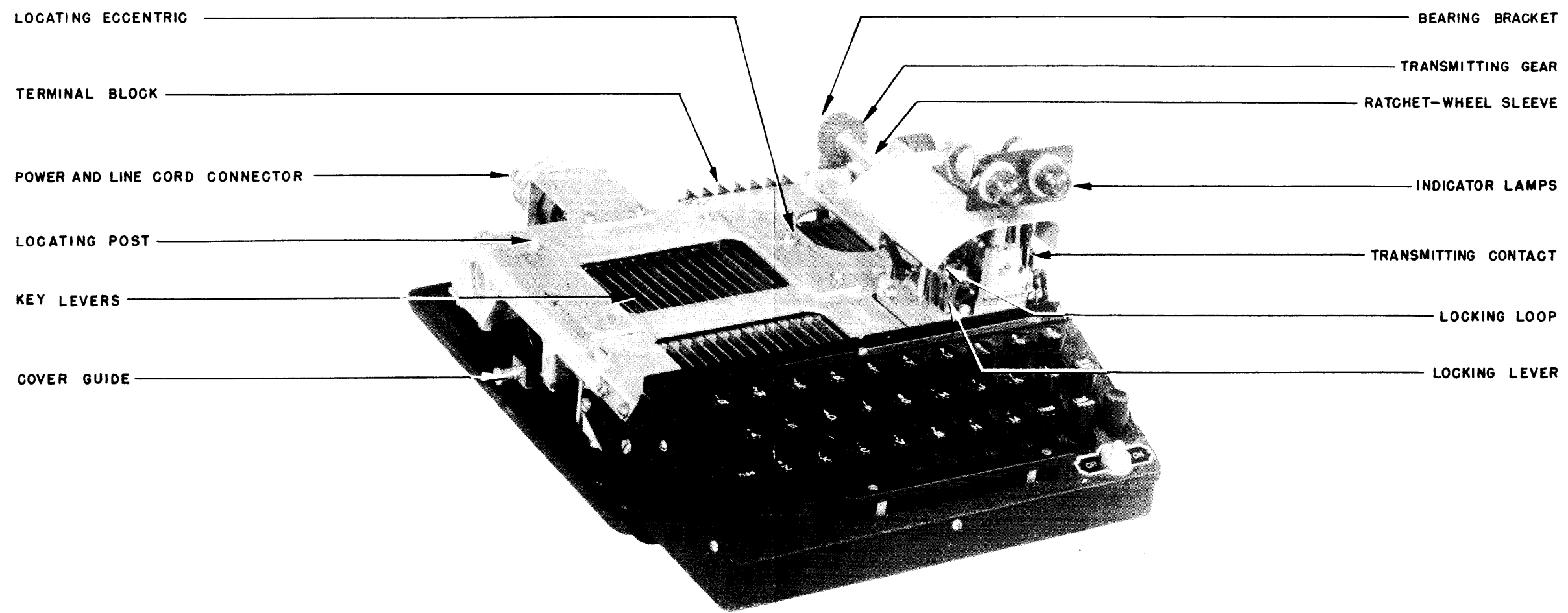

KEYBOARD UNIT

FIGURE 2

UPPER CASE		-	?	:	\$	3	!	@	*	8	,	(	)	.	,	9	0	1	4	'	5	7	;	2	/	6	"	BLANK	C.R.	L.F.		SPACE	LTR. SHIFT	FIG. SHIFT
LOWER CASE	A	B	C	D	E	F	G	H	I	J	K	L	M	N	O	P	Q	R	S	T	U	V	W	X	Y	Z								
1	●	●	●	●	●	●	●	●	●	●	●	●	●	●	●	●	●	●	●	●	●	●	●	●	●	●	●	●	●	●	●	●	●	
2	●	●	●	●	●	●	●	●	●	●	●	●	●	●	●	●	●	●	●	●	●	●	●	●	●	●	●	●	●	●	●	●	●	
FEED HOLES	○	○	○	○	○	○	○	○	○	○	○	○	○	○	○	○	○	○	○	○	○	○	○	○	○	○	○	○	○	○	○	○	○	
3	●	●	●	●	●	●	●	●	●	●	●	●	●	●	●	●	●	●	●	●	●	●	●	●	●	●	●	●	●	●	●	●	●	
4	●	●	●	●	●	●	●	●	●	●	●	●	●	●	●	●	●	●	●	●	●	●	●	●	●	●	●	●	●	●	●	●	●	
5	●	●	●	●	●	●	●	●	●	●	●	●	●	●	●	●	●	●	●	●	●	●	●	●	●	●	●	●	●	●	●	●	●	

FIGURE 3

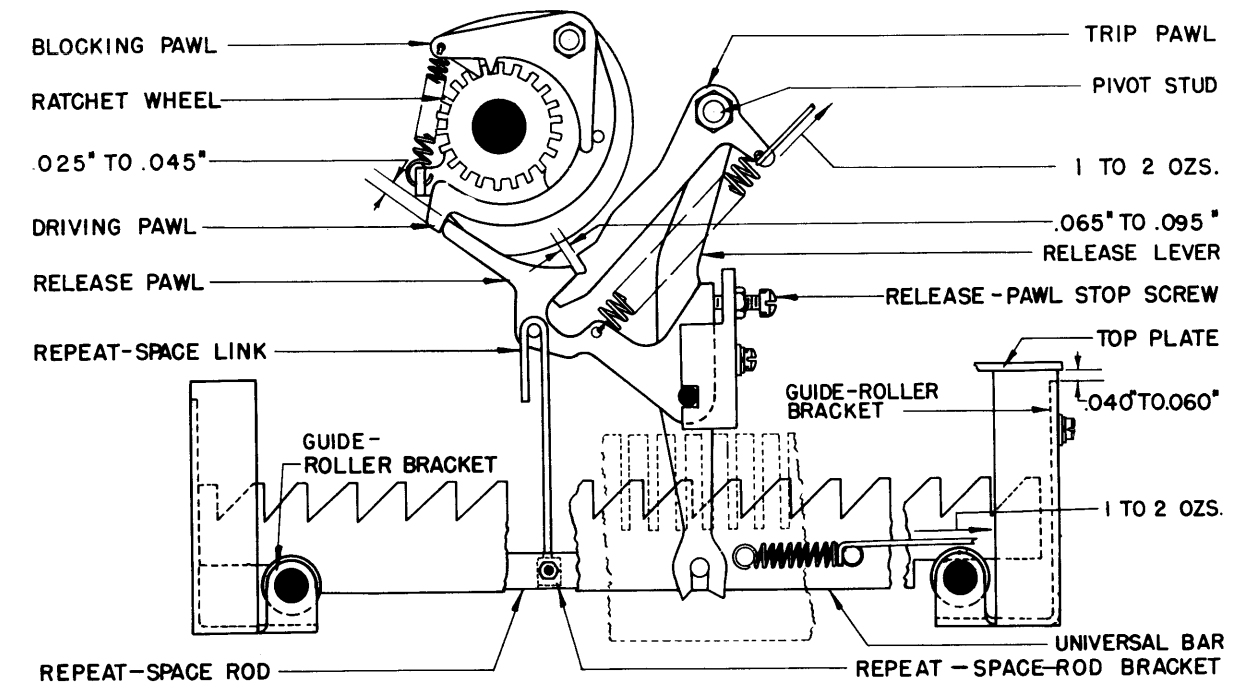

FIGURE 5

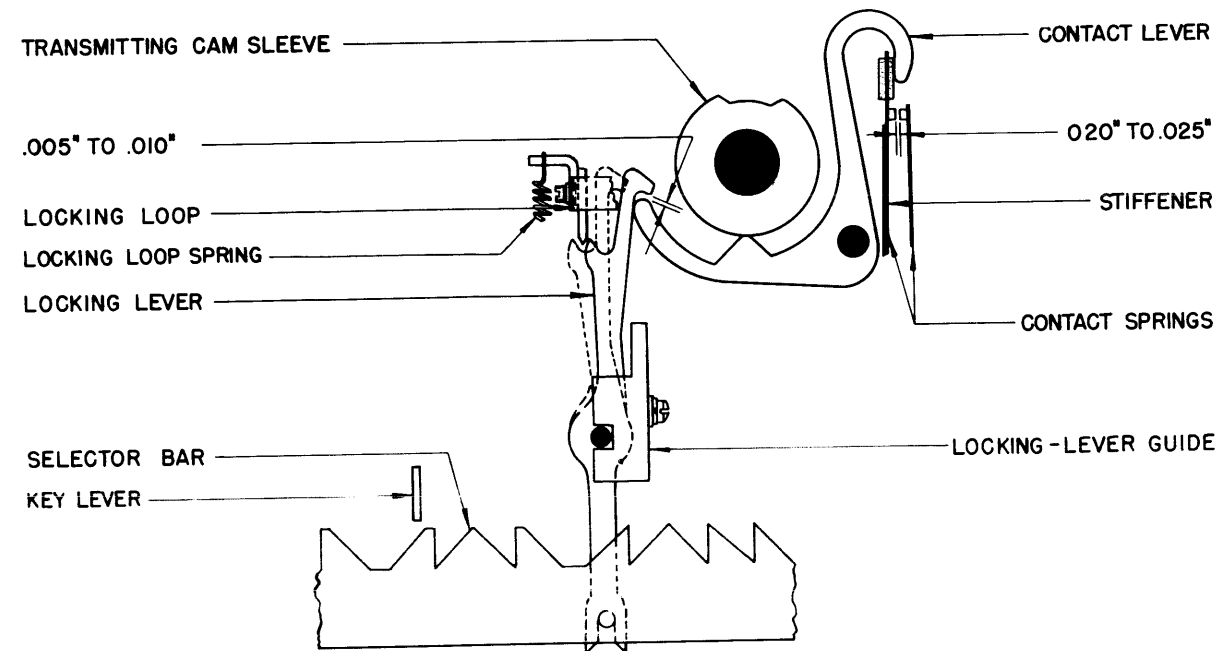

FIGURE 4

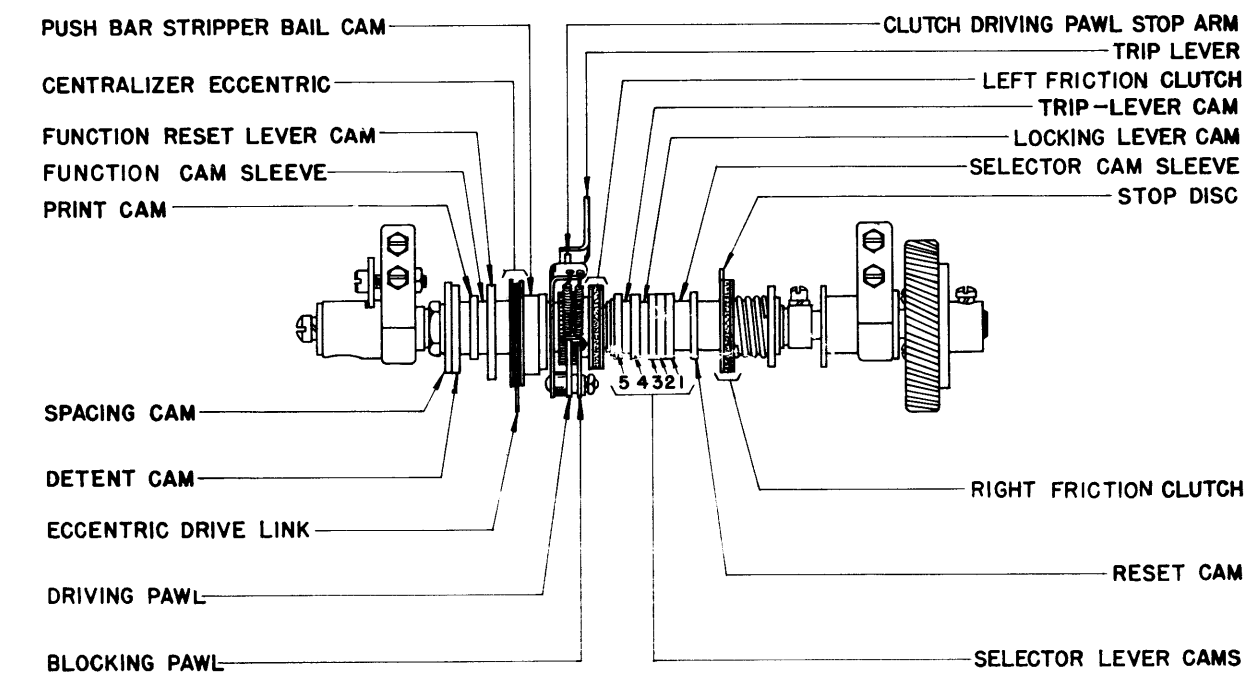

FIGURE 6

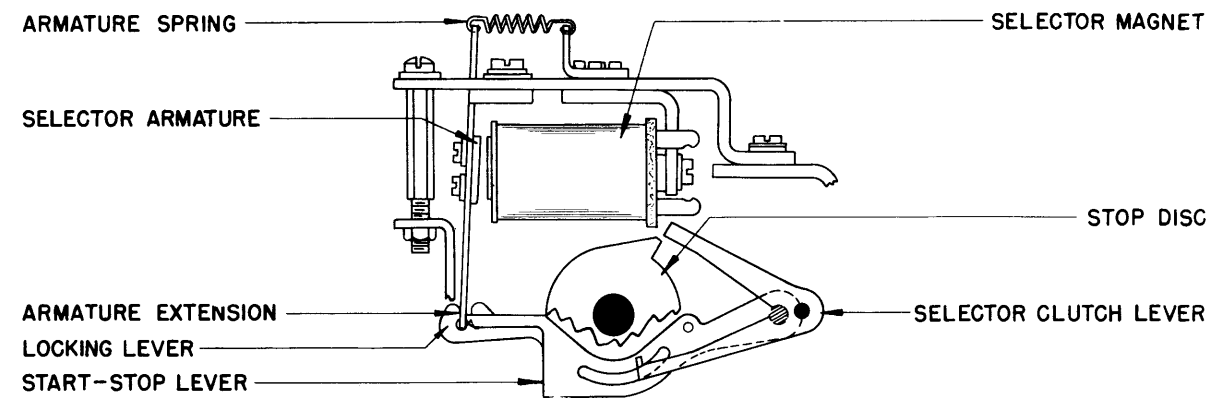

FIGURE 7

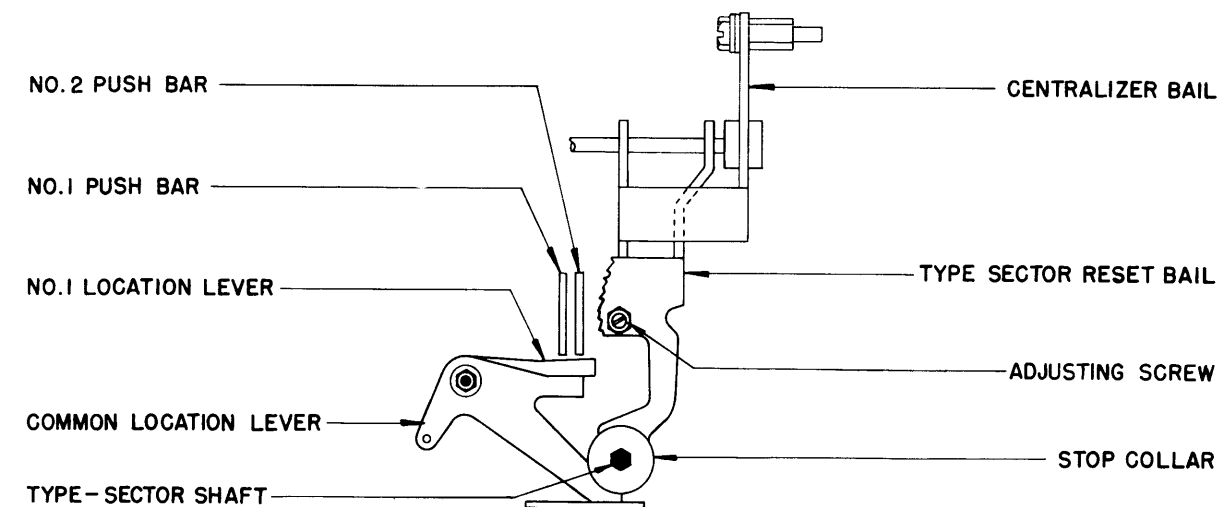

FIGURE 9

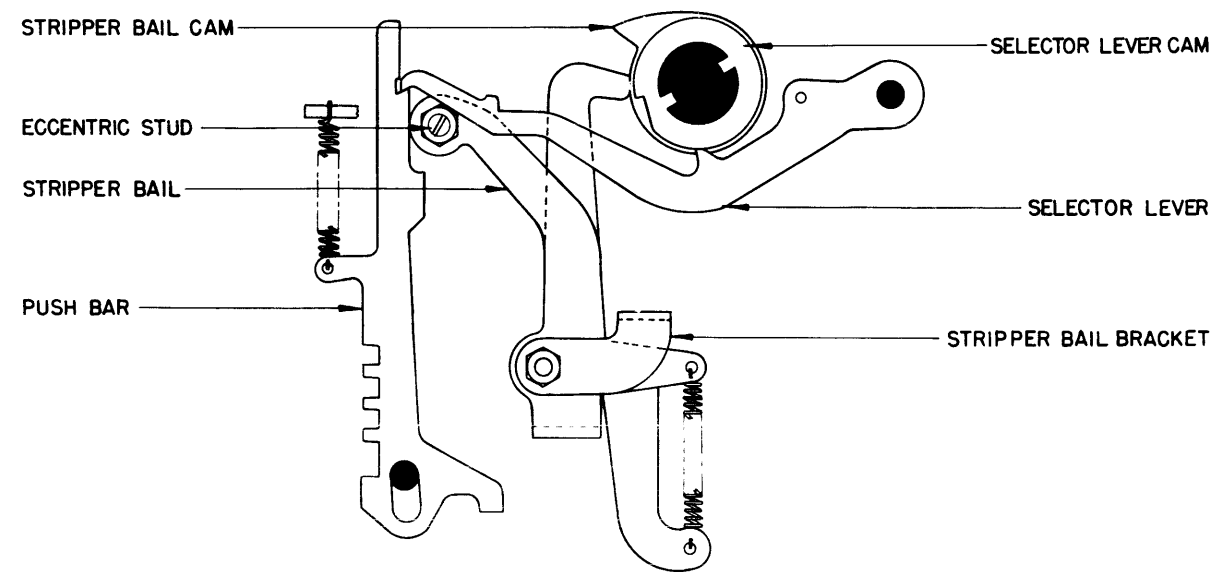

FIGURE 8

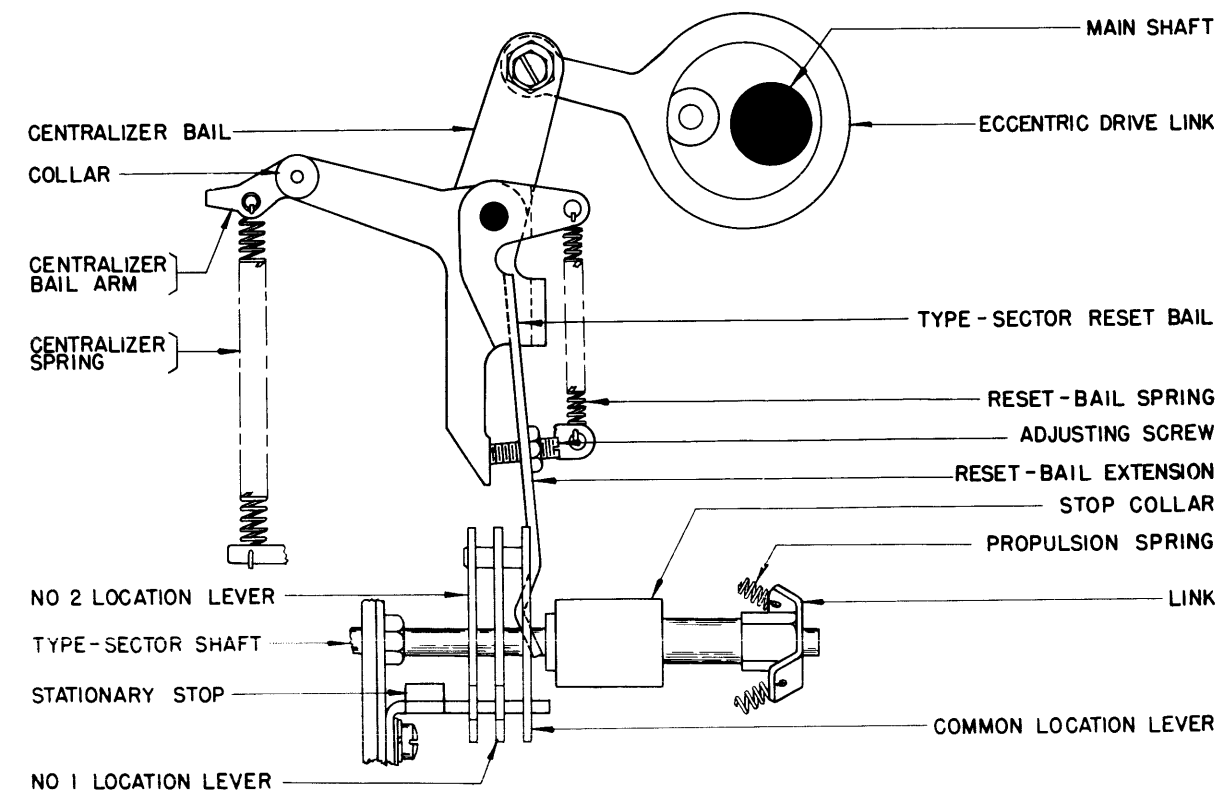

FIGURE 10

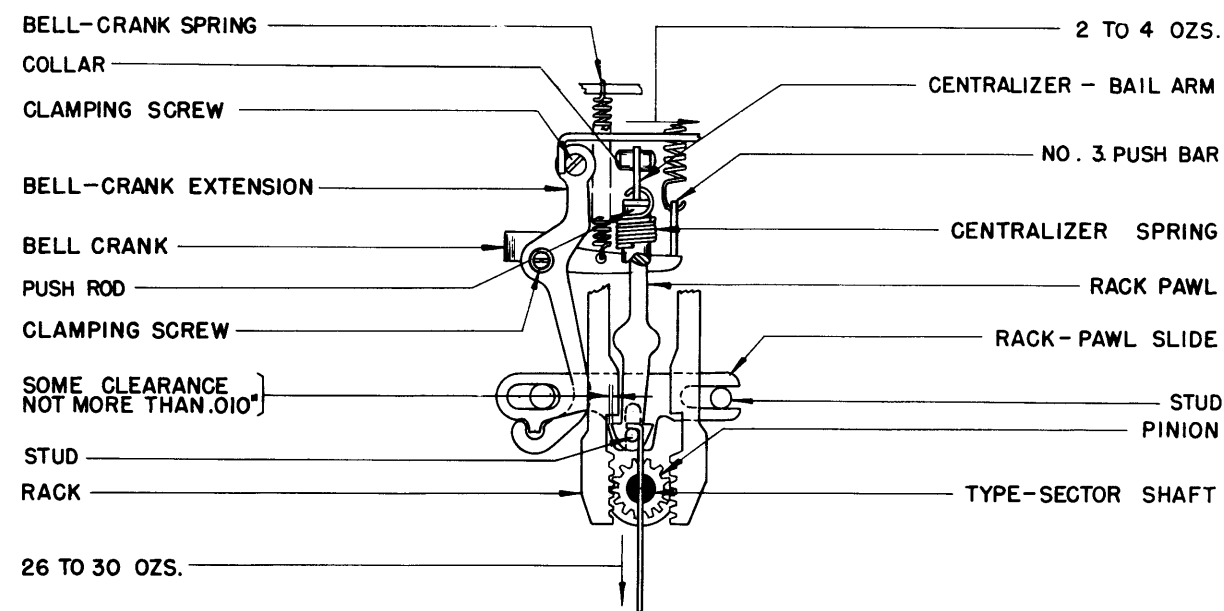

FIGURE 11

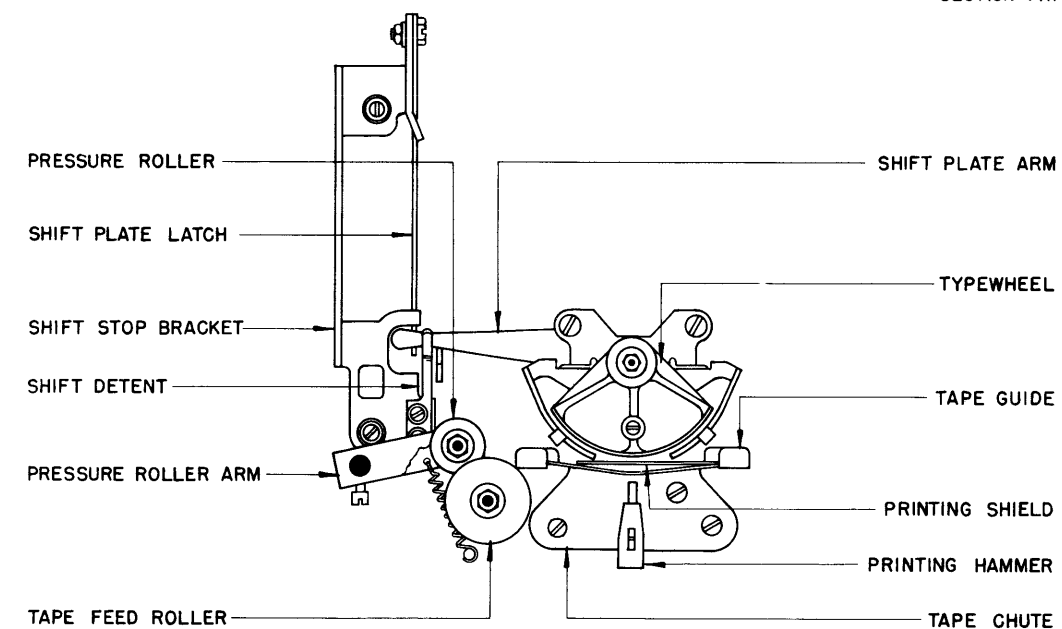

FIGURE 13

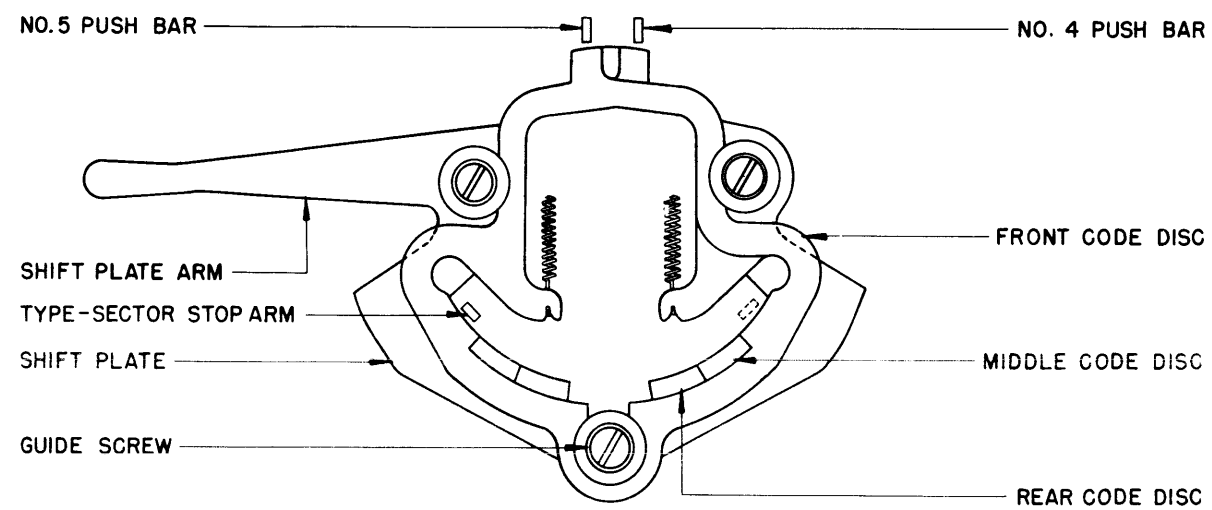

FIGURE 12

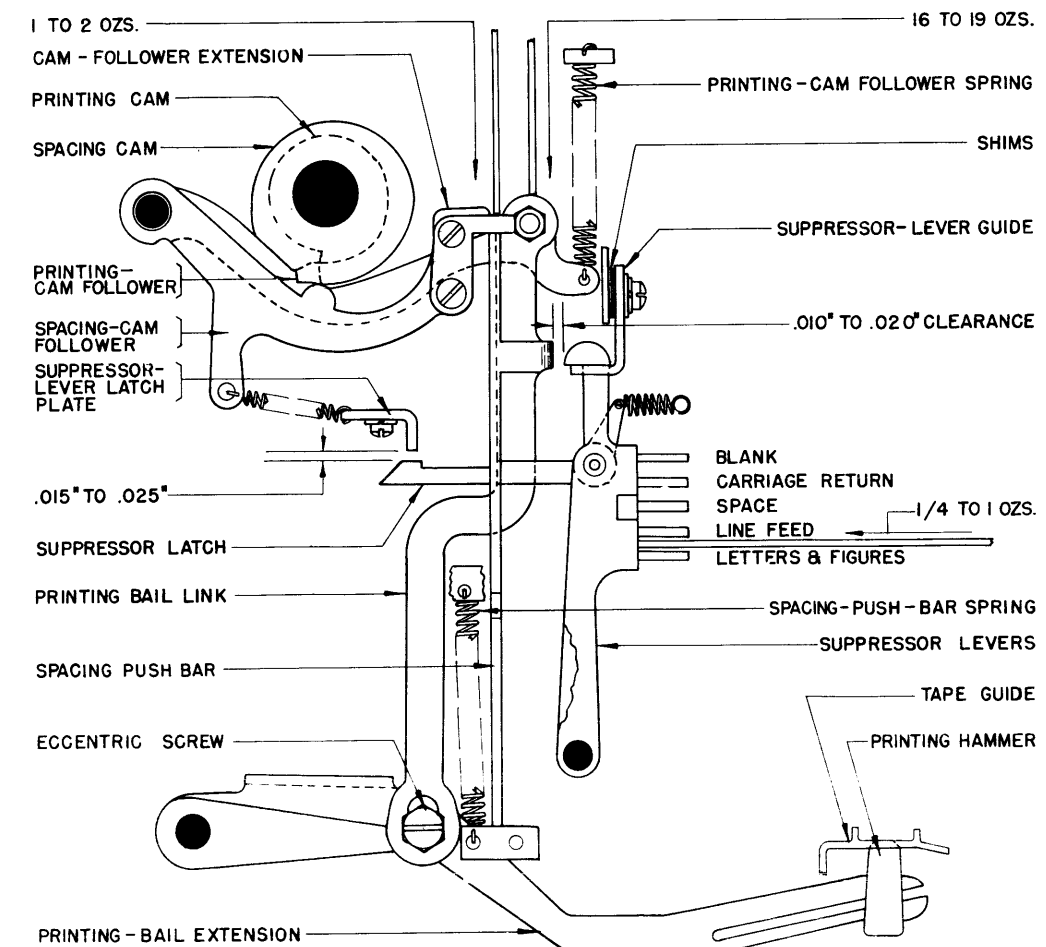

FIGURE 14

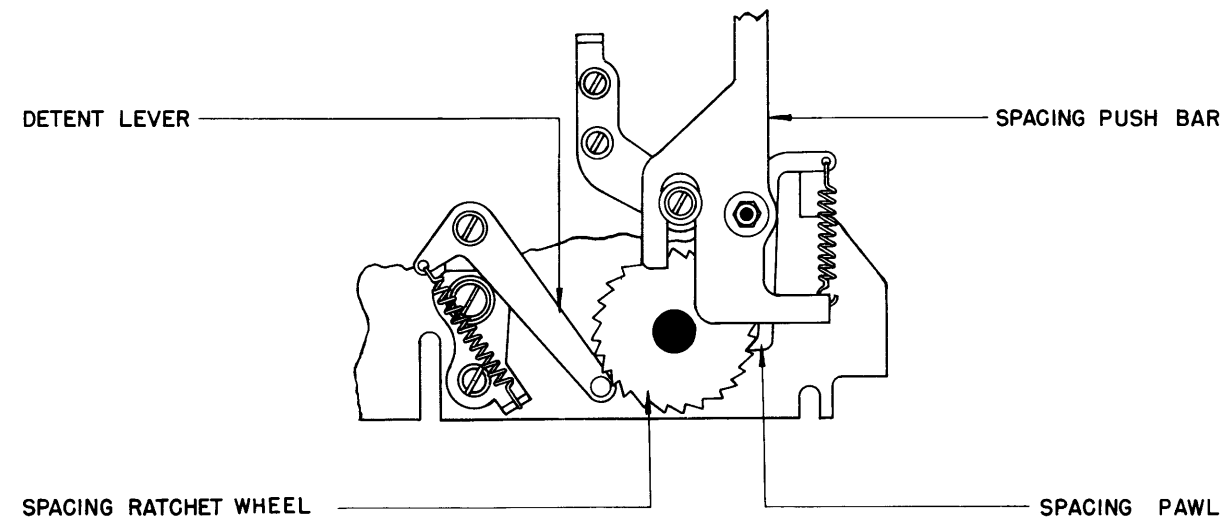

FIGURE 15

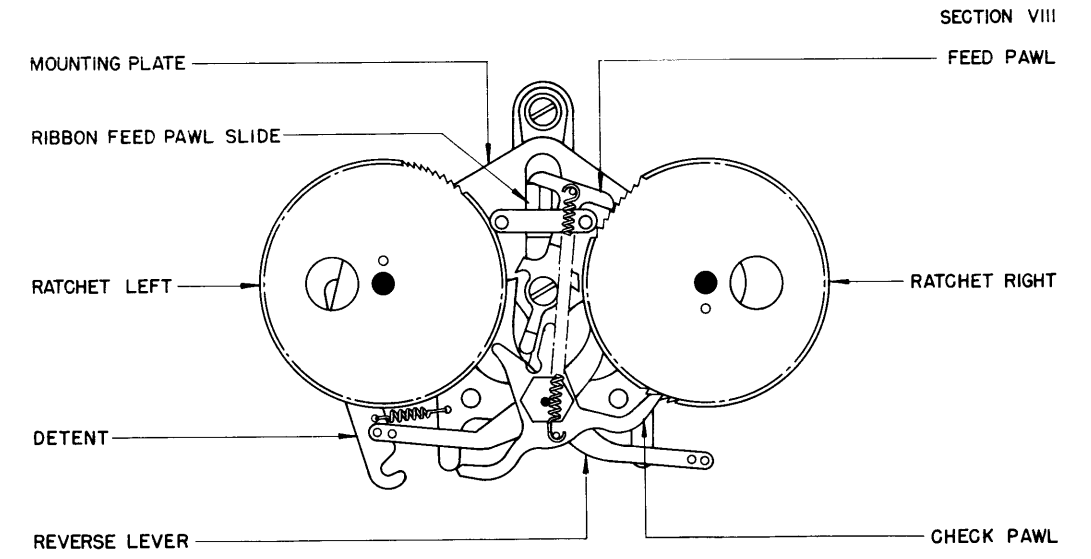

FIGURE 17

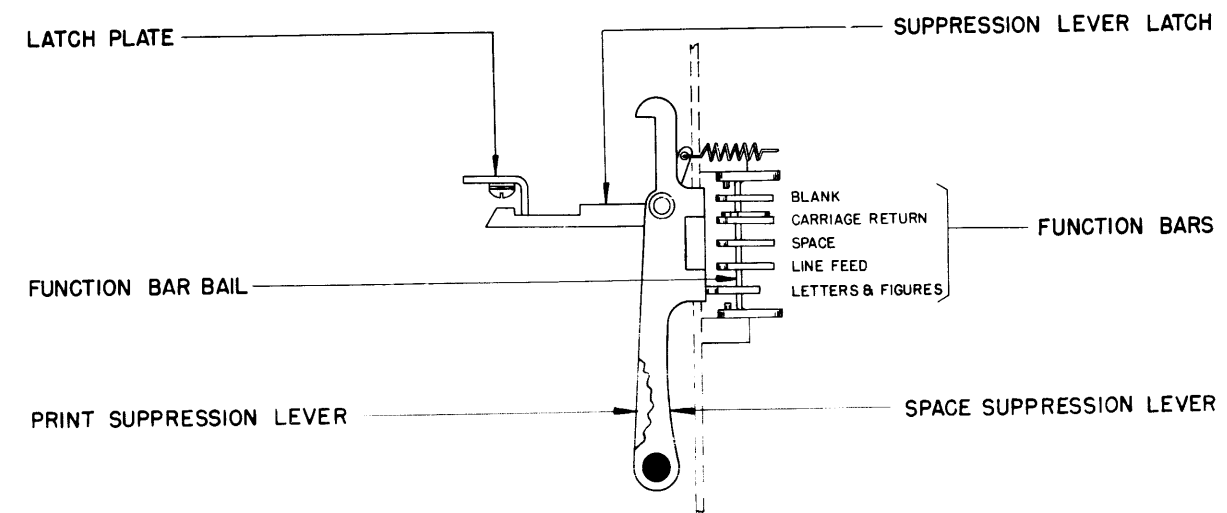

FIGURE 16

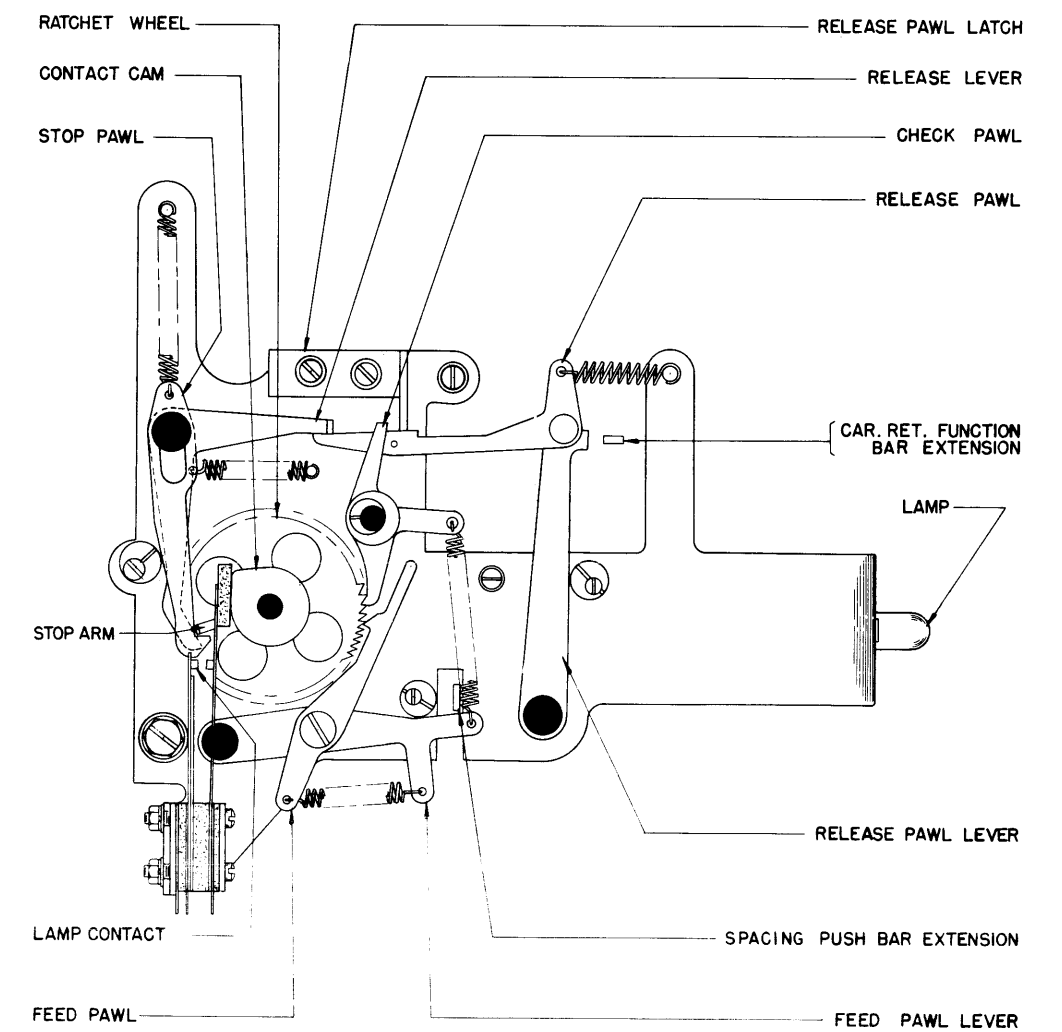

FIGURE 18

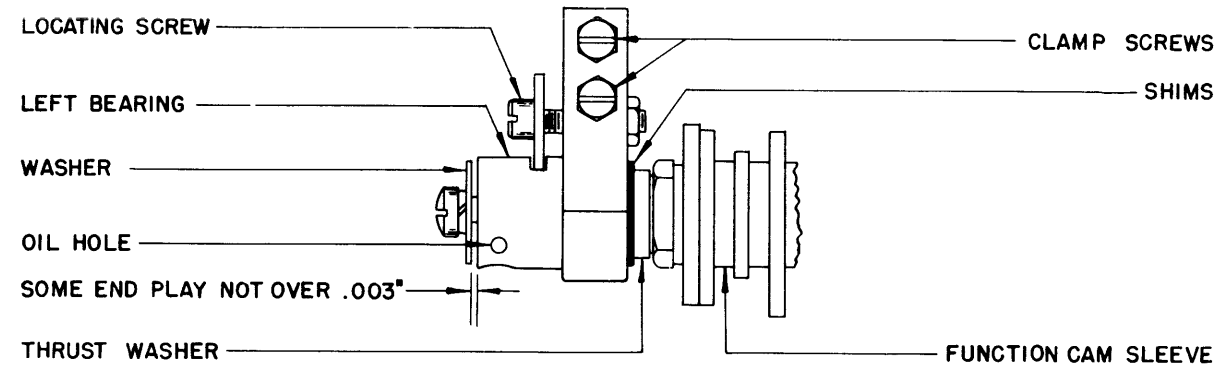

FIGURE 19

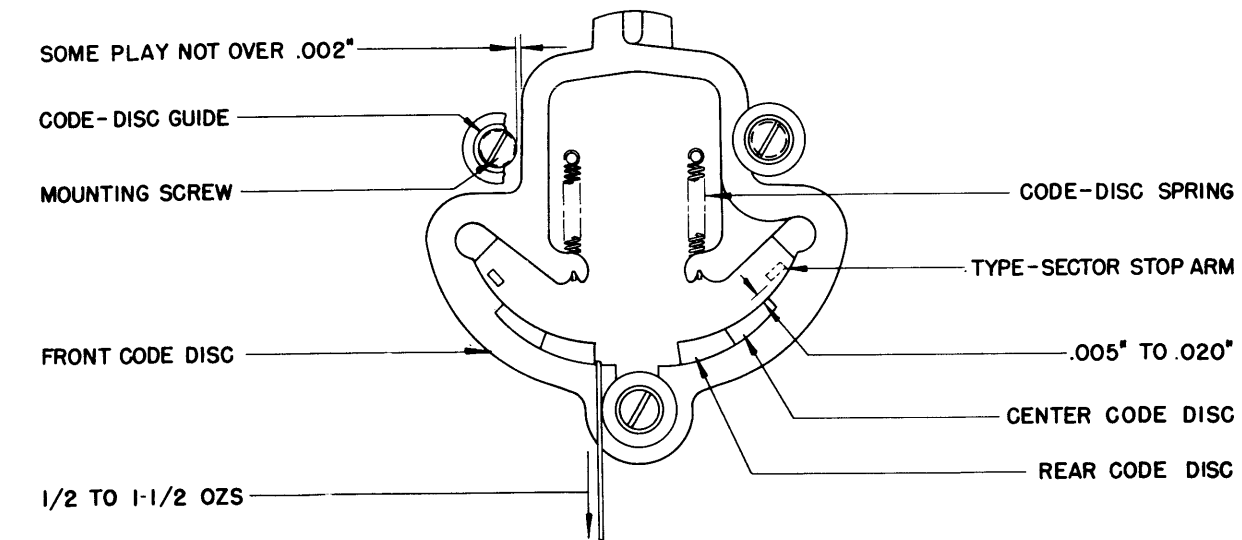

FIGURE 22

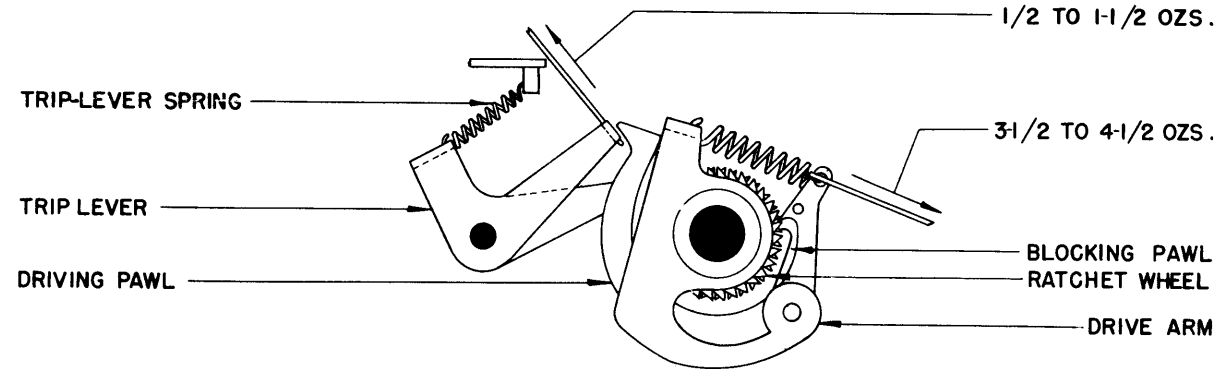

FIGURE 20

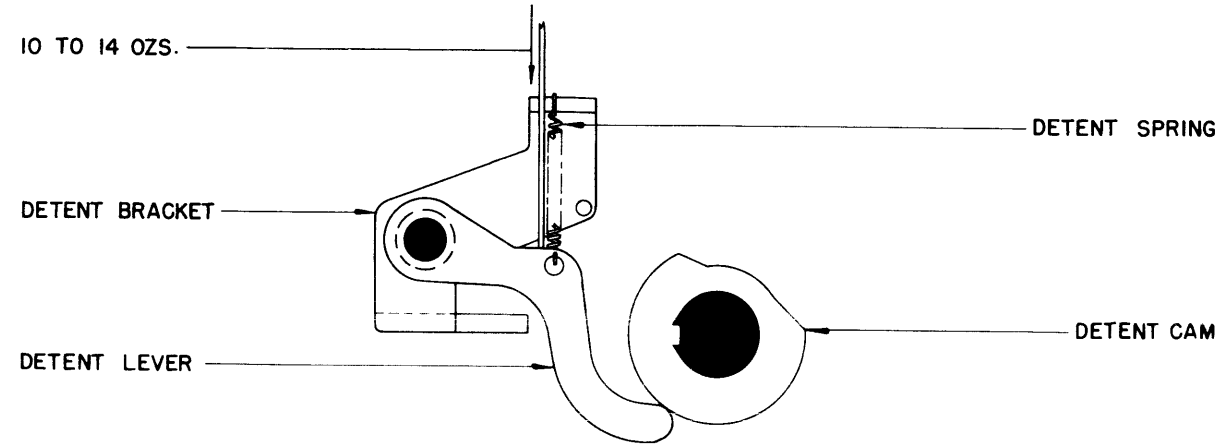

FIGURE 21

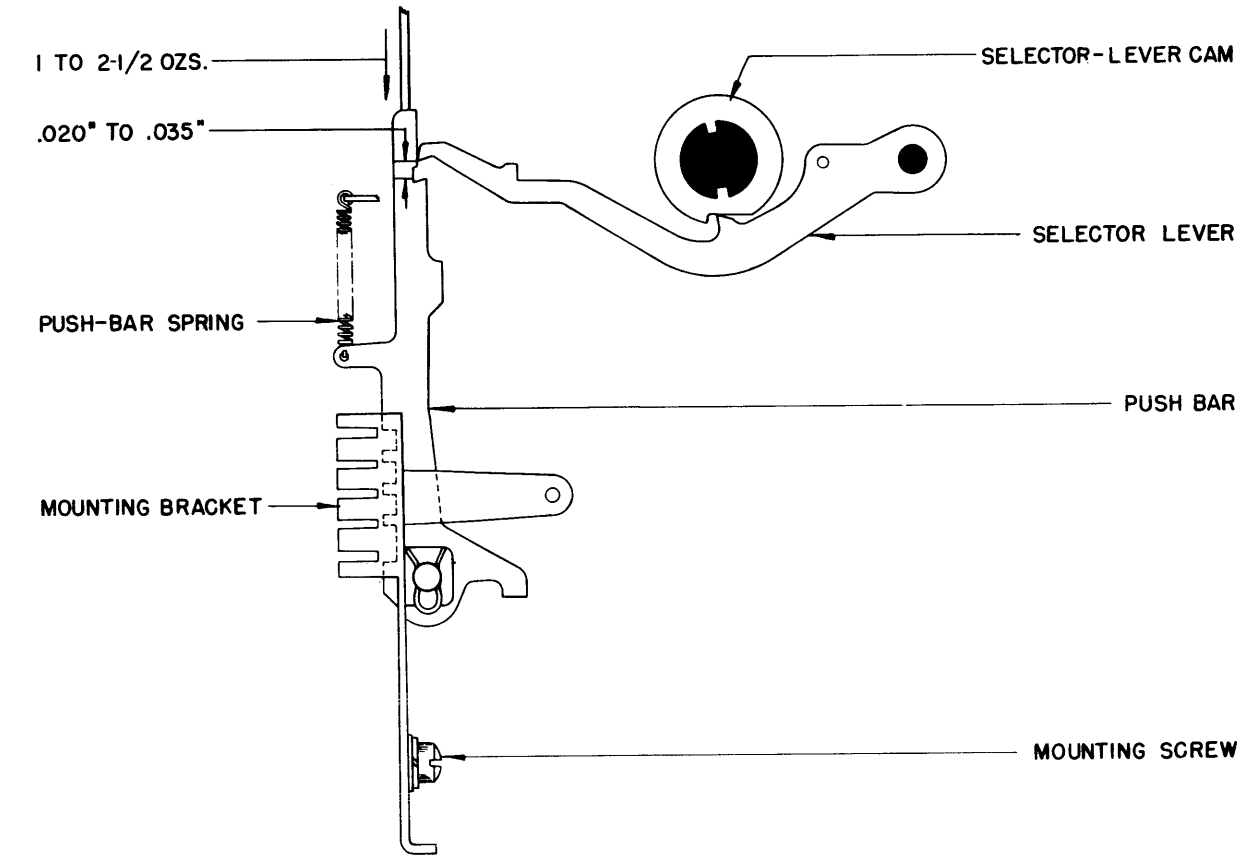

FIGURE 23

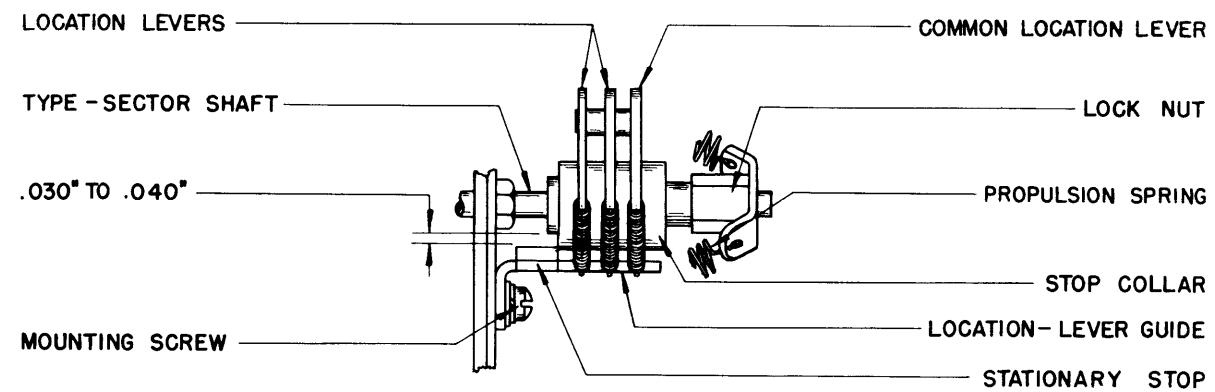

FIGURE 24

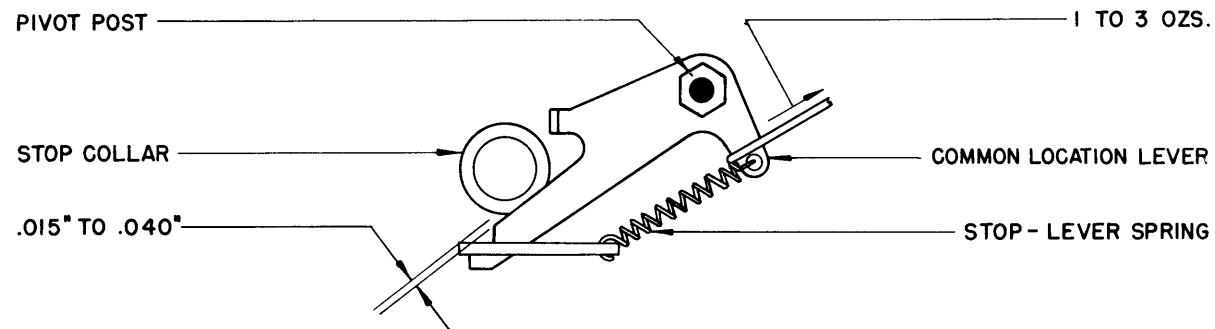

FIGURE 25

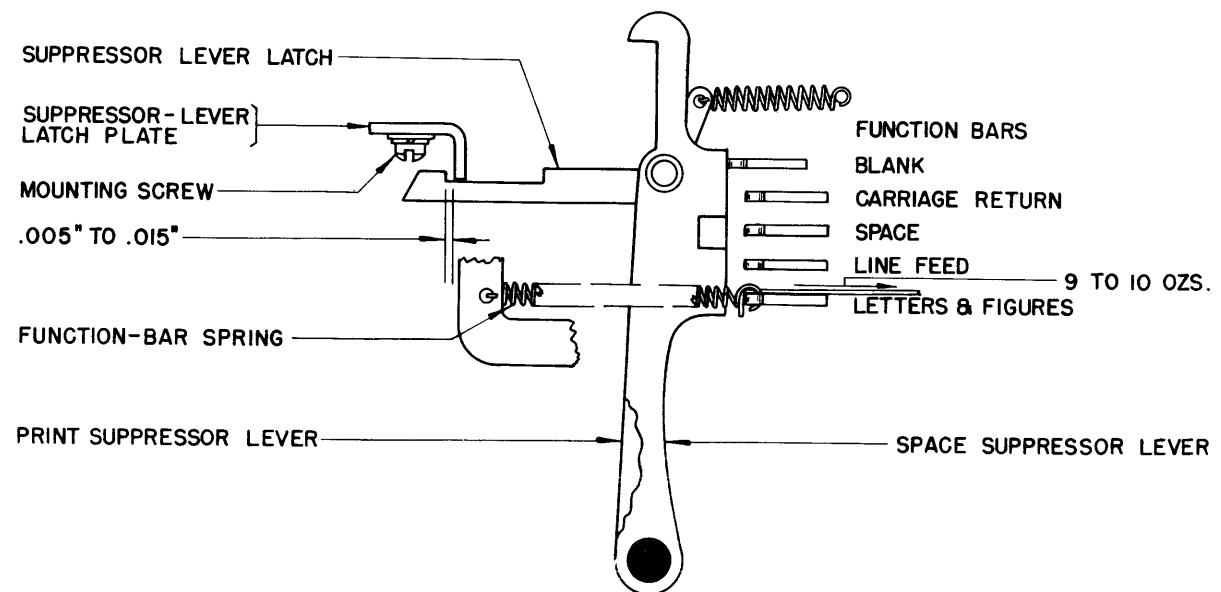

FIGURE 26

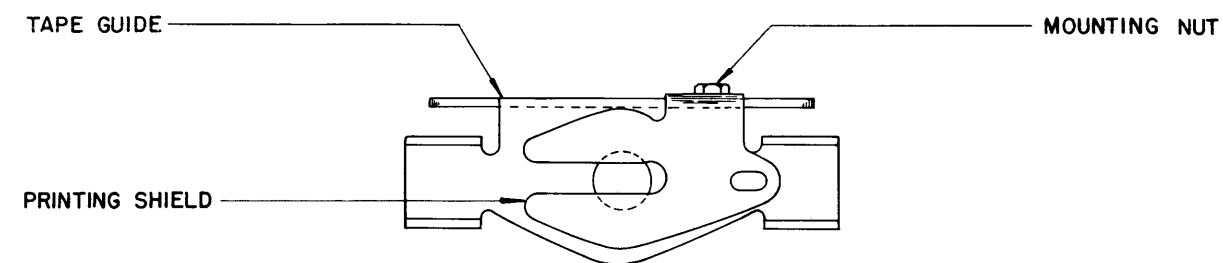

FIGURE 27

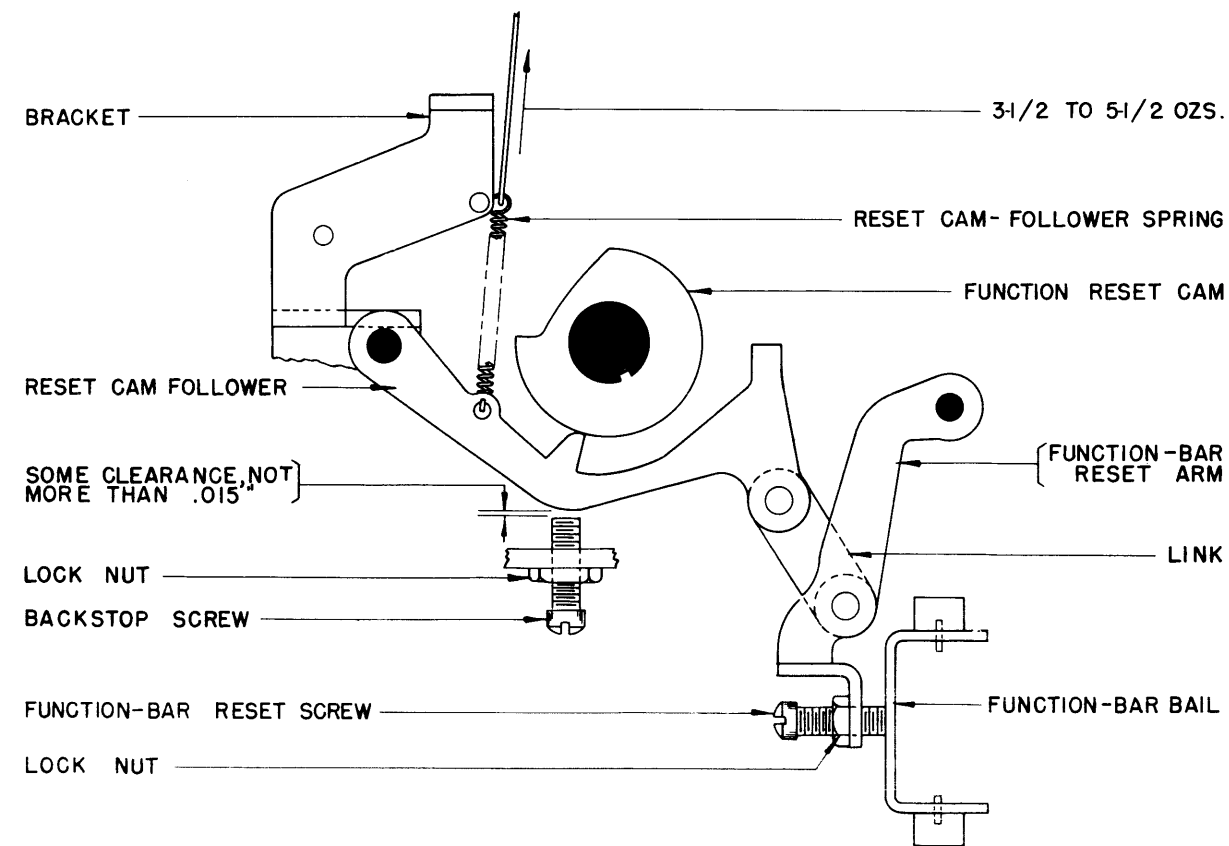

FIGURE 28

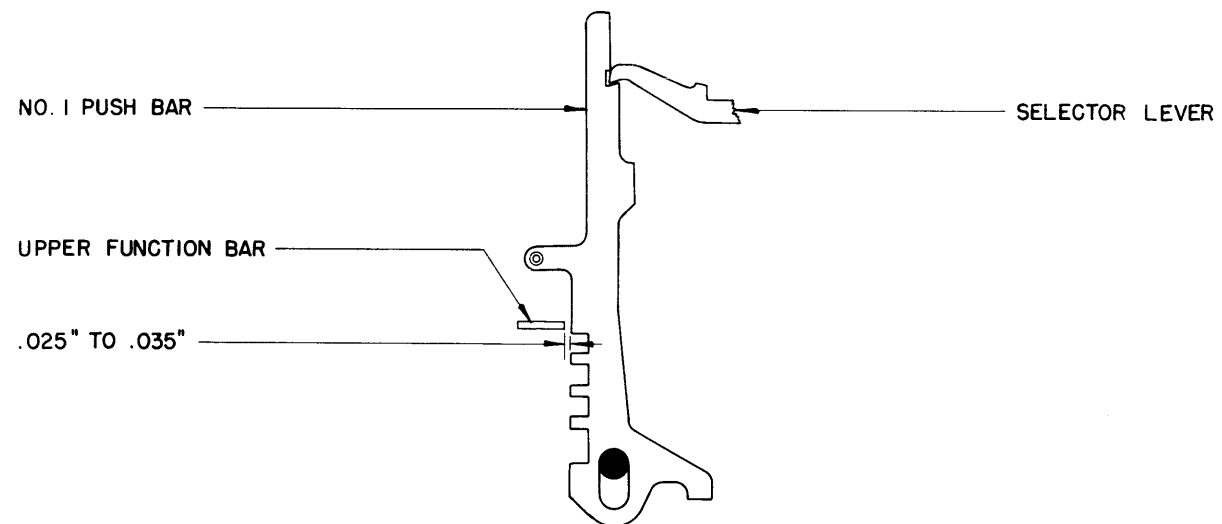

FIGURE 29

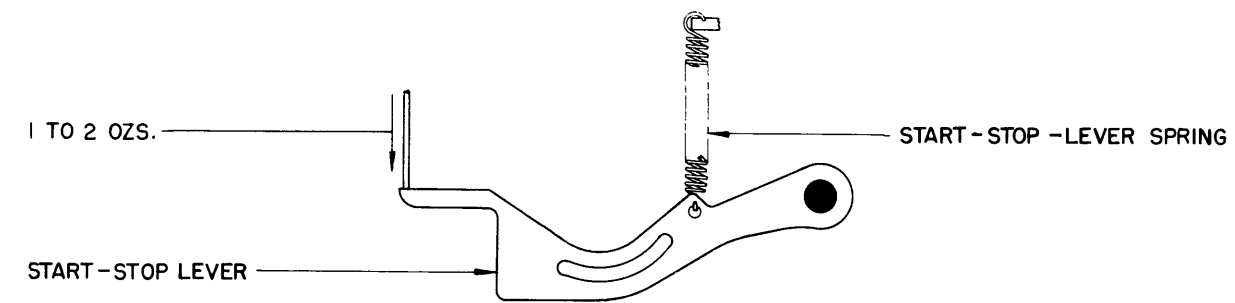

FIGURE 32

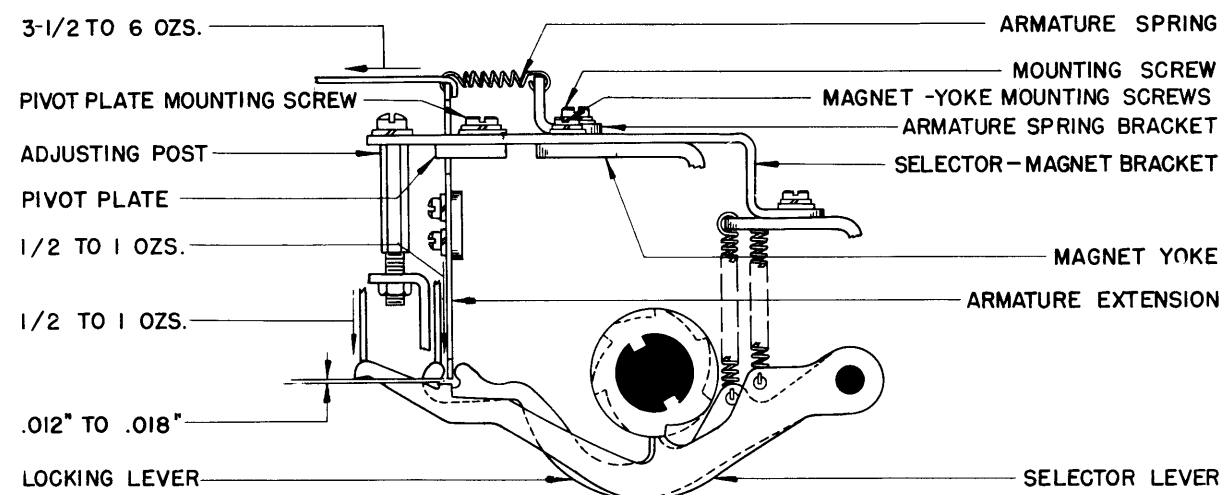

FIGURE 30

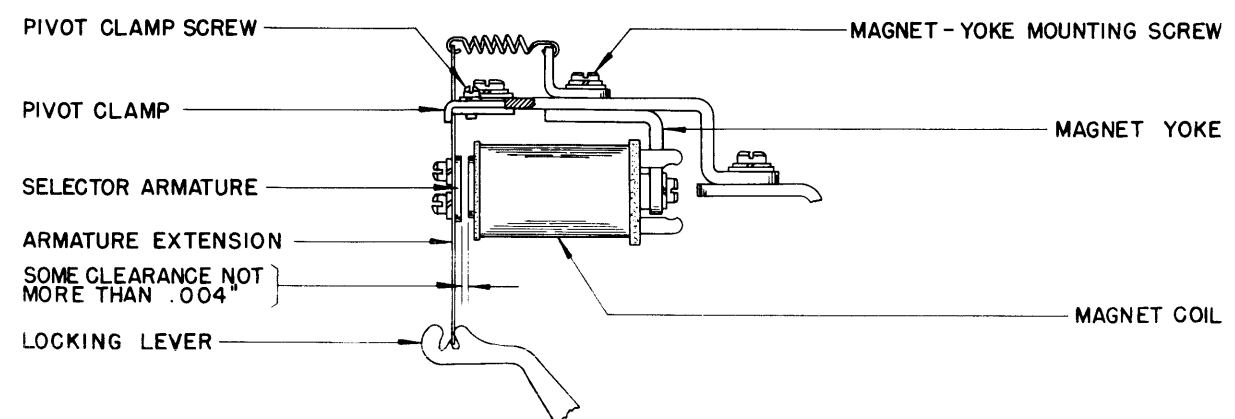

FIGURE 31

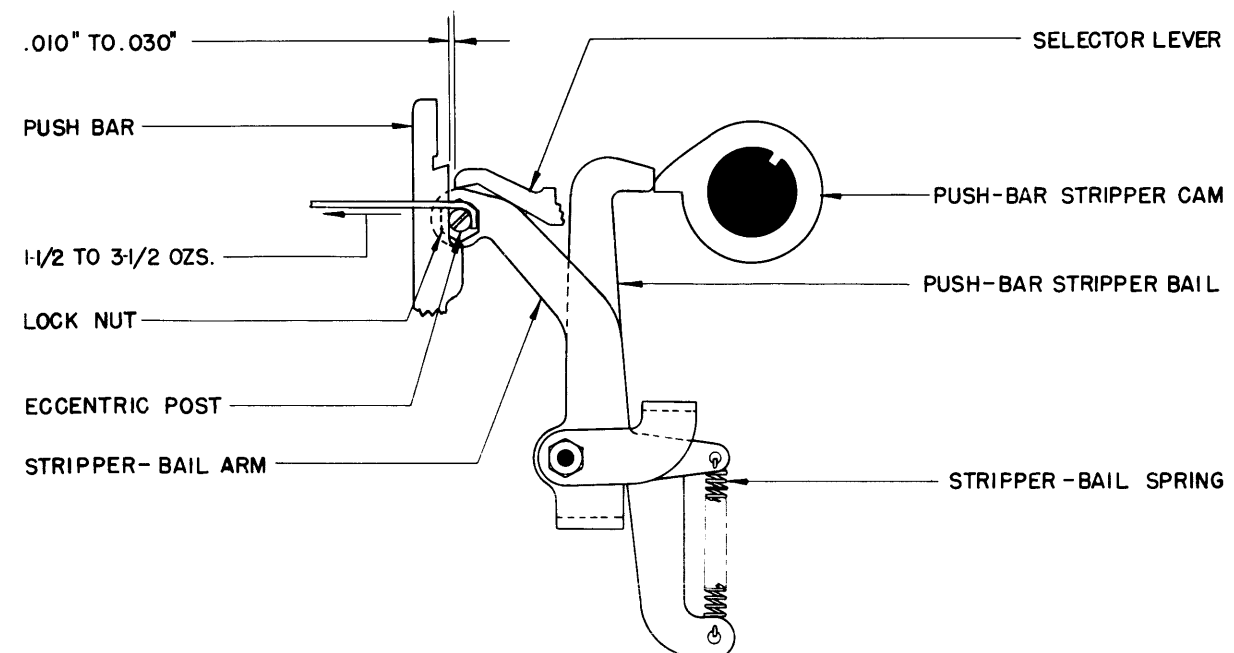

FIGURE 33



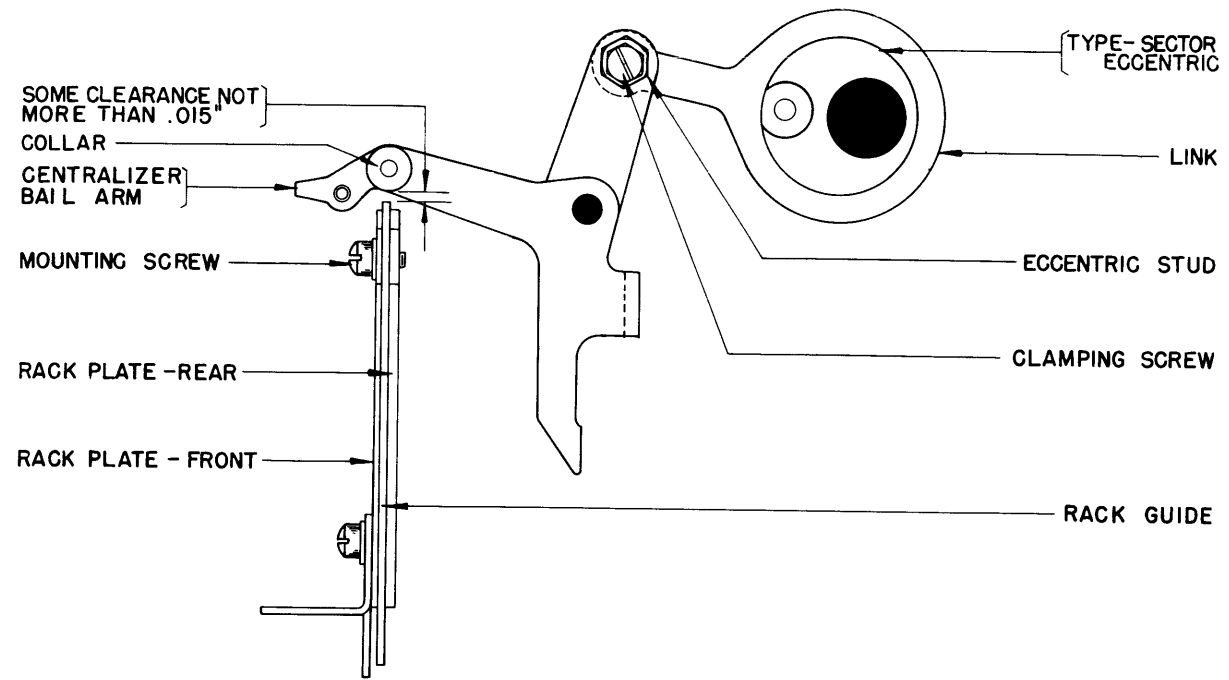

FIGURE 34

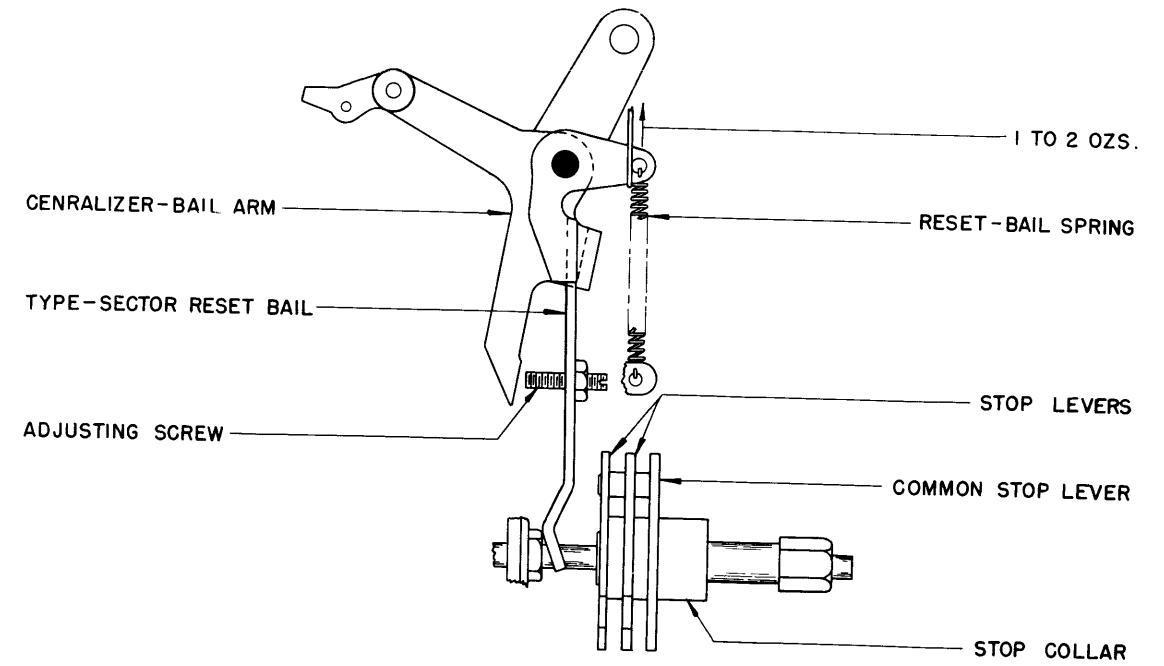

FIGURE 36

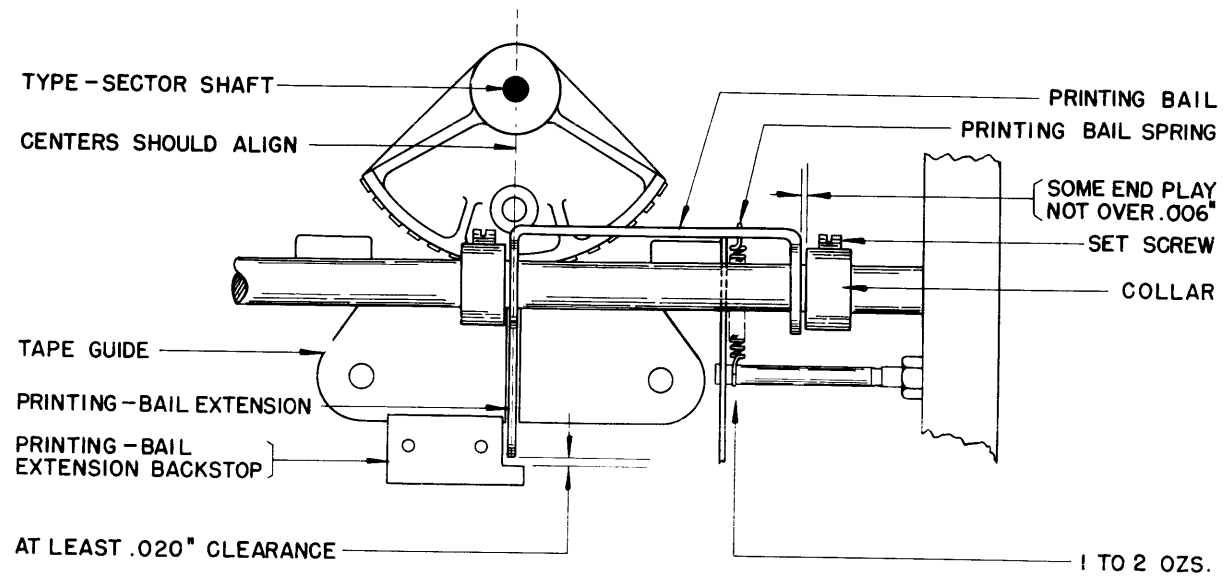

FIGURE 35

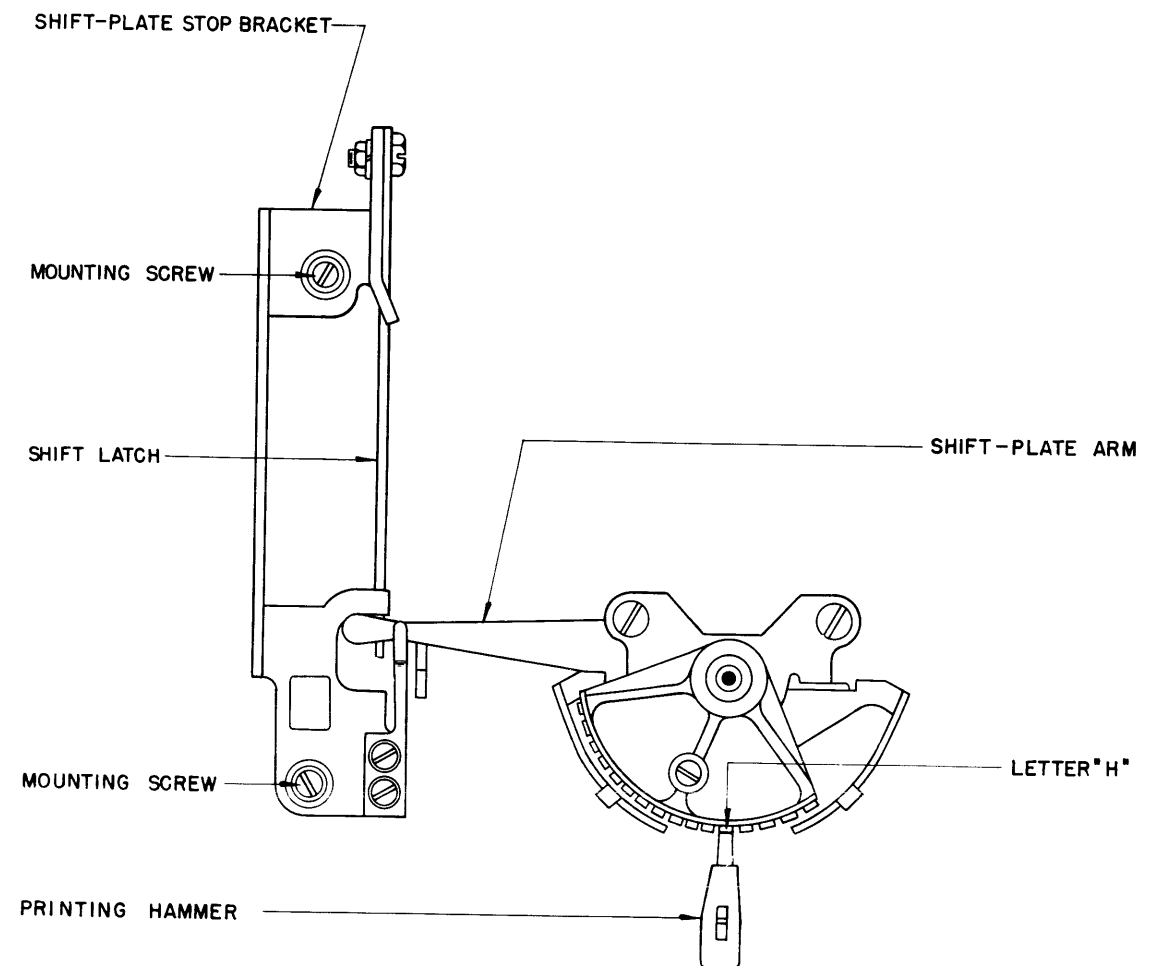

FIGURE 37

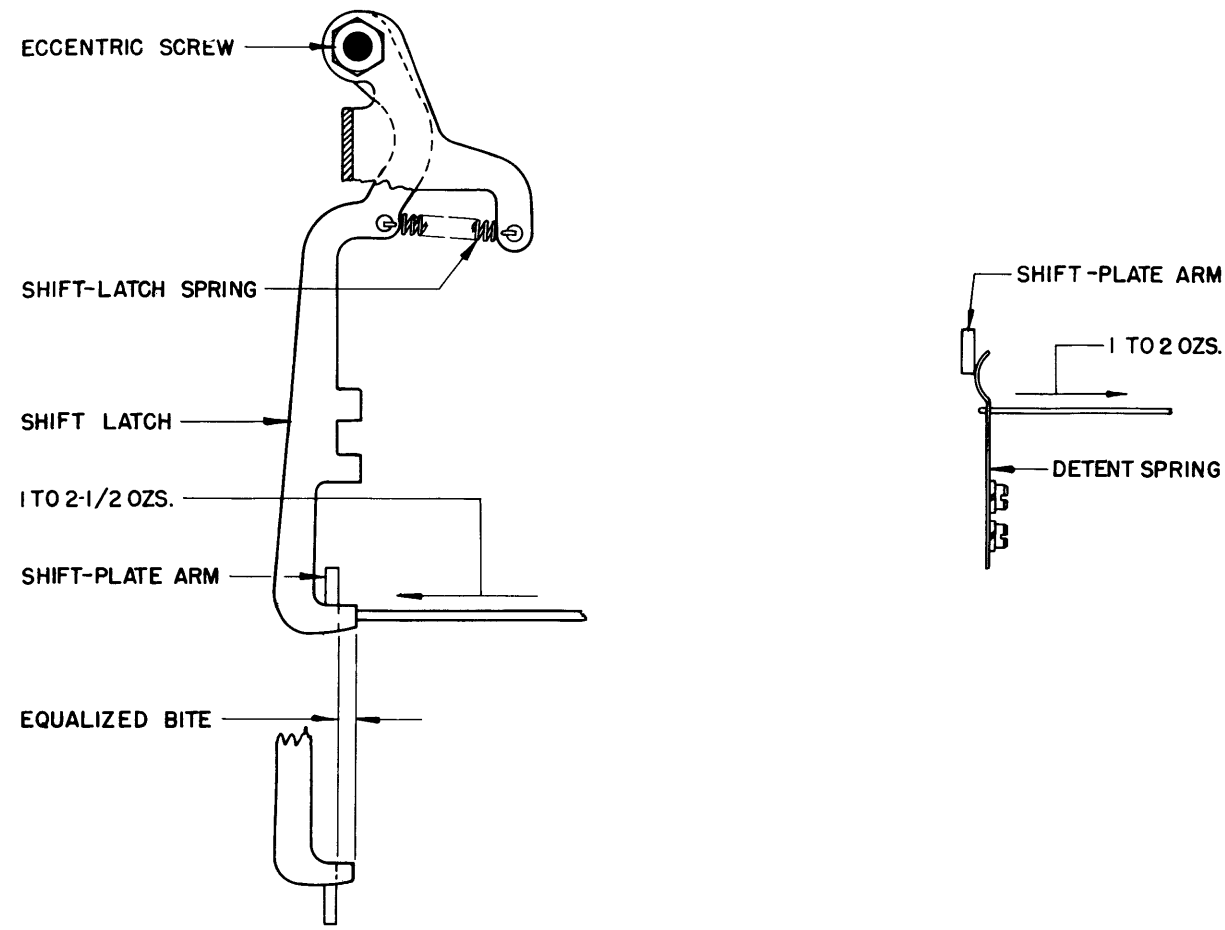

FIGURE 38

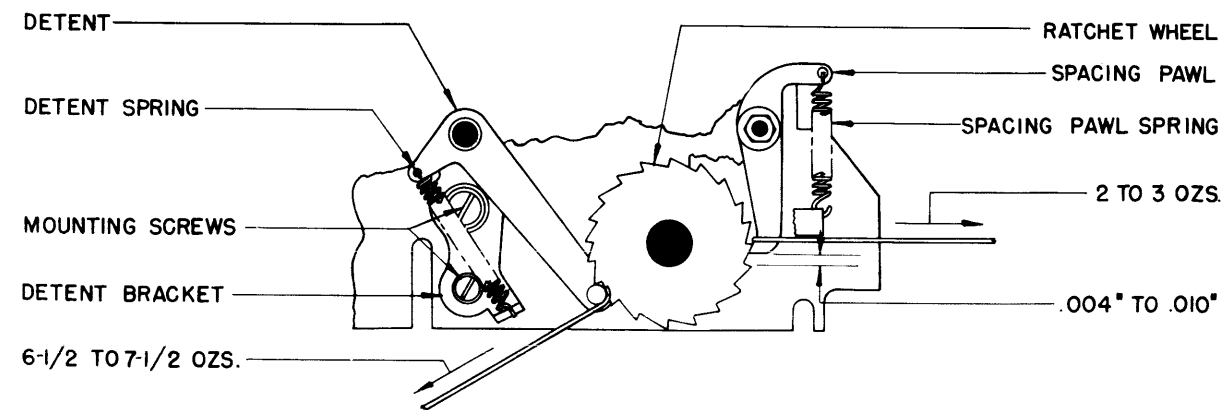

FIGURE 39

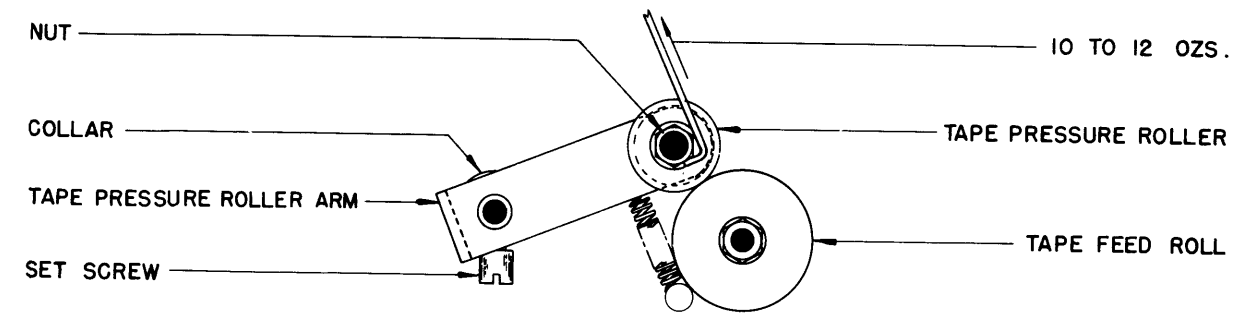

FIGURE 40

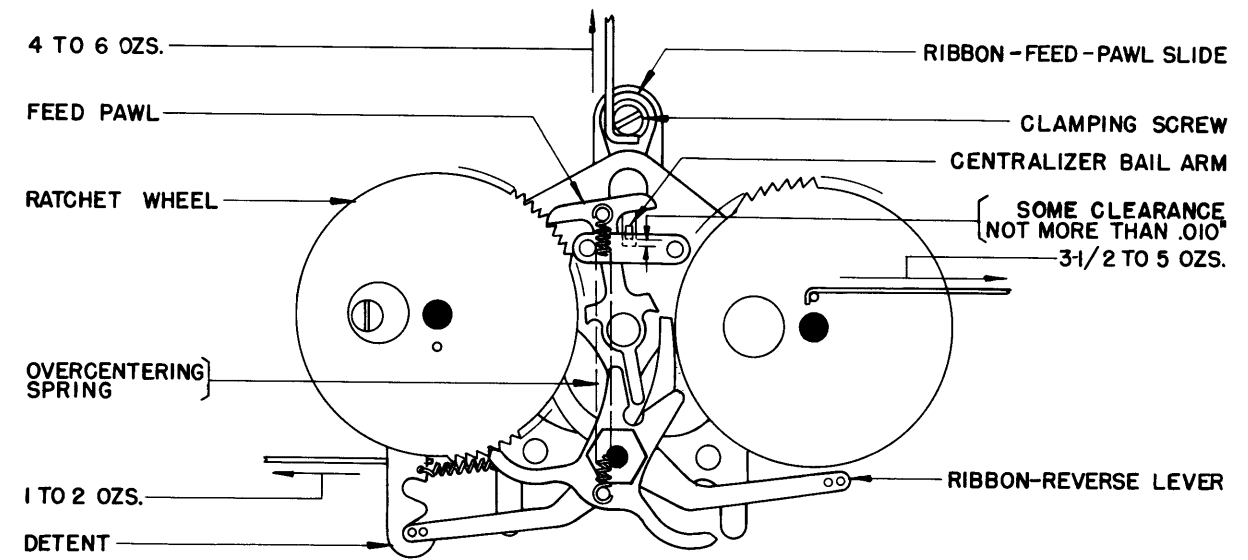

FIGURE 41

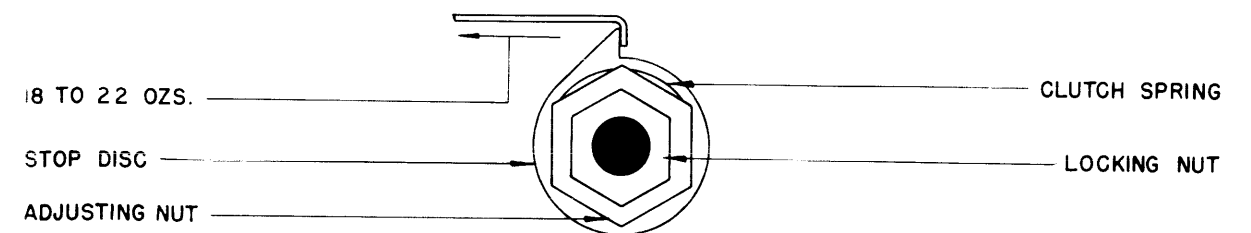

FIGURE 42

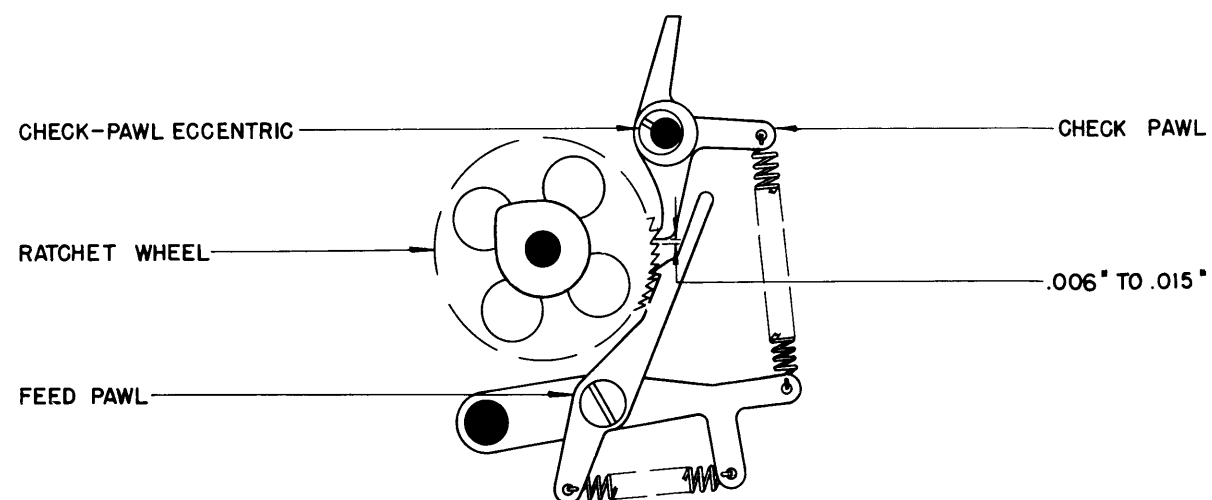

FIGURE 43

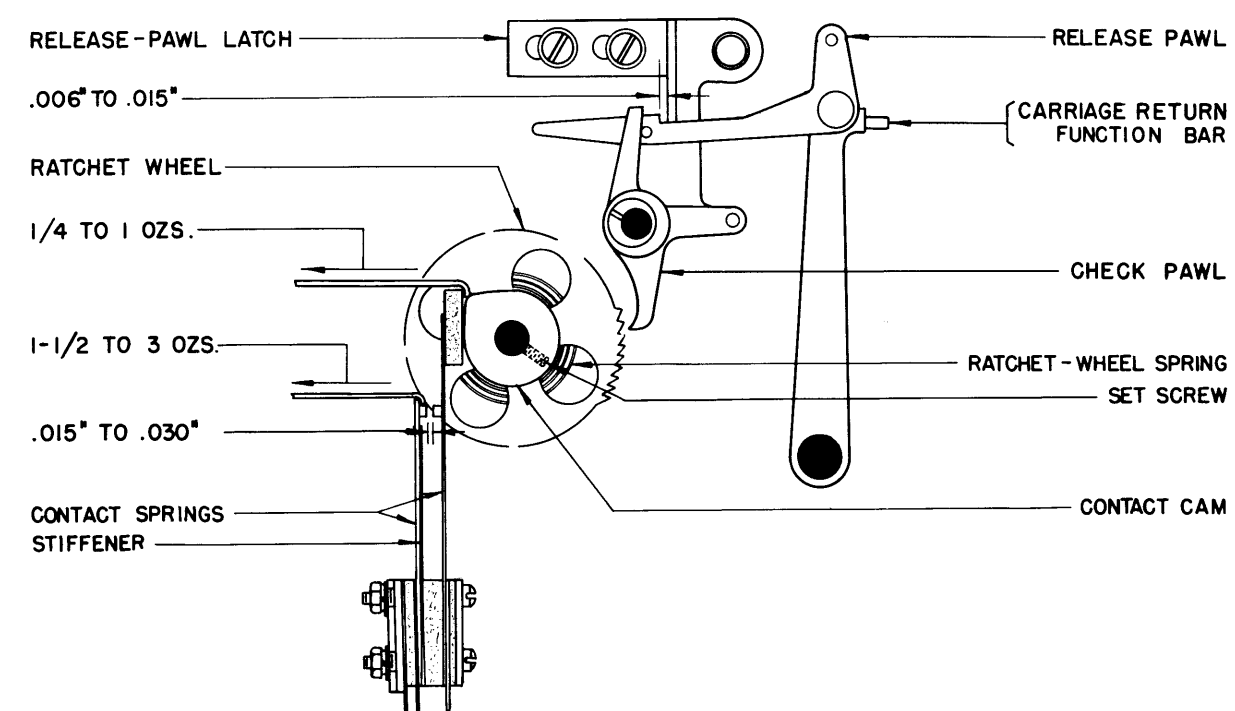

FIGURE 45

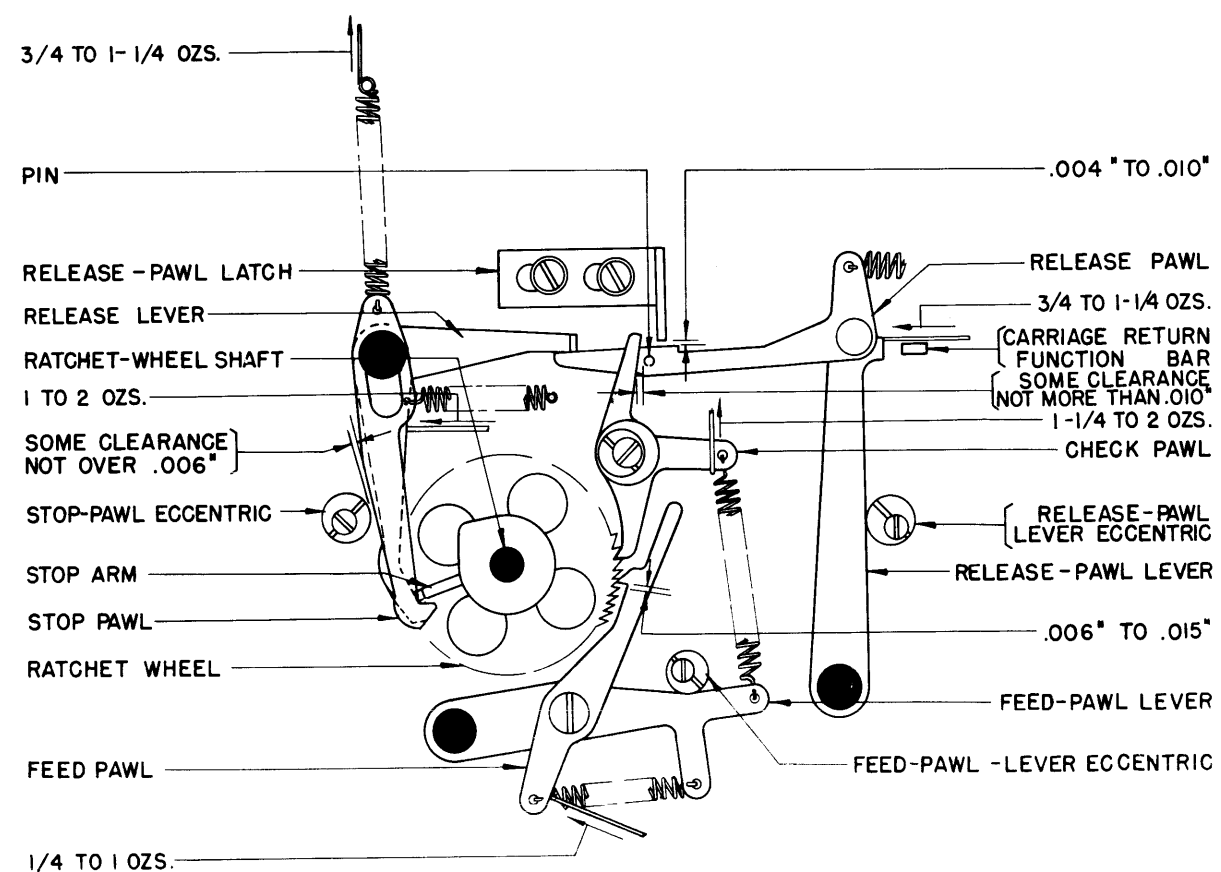

FIGURE 44

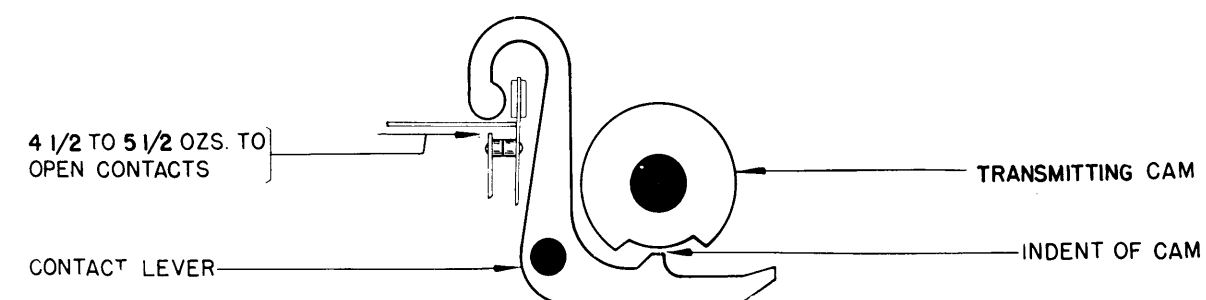

FIGURE 46



FIGURE 47



CHANGES AND ADDITIONS  
TO BULLETIN 200, ISSUE 1  
MODEL 31 TAPE PRINTER

Section II, Paragraph 1.d. Page 2-0

Delete all of this paragraph except the first and second sentence.

Paragraph 1.h. Page 2-1

Delete this paragraph.

Paragraph 2.h. Page 2-4

Delete this paragraph.

Paragraph 2.i. Page 2-4

Delete the second sentence of this paragraph.

Section III, Paragraph 2.a.(25)(a) Page 3-3

In the fifth line, change "marking position" to "spacing position".

Paragraph 2.a.(25)(c) Page 3-3

Add to this requirement "To adjust, position the selector-magnet adjusting post."

Paragraph 2.a.(27) Page 3-3

In the first and second line, change "No. 1 selector lever" to "No. 2 selector lever".

Change the last sentence to read: "It should require from 1/4 to 3/4 oz. to start the numbers 1, 3, 4, 5 selector levers moving."

Paragraph 2.a.(35) Page 3-4

Immediately following this adjustment add: When making this adjustment, the eccentric stud must be in its lowest position for proper operation.

Paragraph 2.a.(69) Page 3-8

Add the following immediately prior to Paragraph 2.a.(69):

(68.1) MOTOR POSITION ADJUSTMENT

There should be a perceptible amount of backlash between the motor pinion and its gear. To adjust, position the motor assembly by means of the motor bracket upper mounting screws.

(68.2) GOVERNOR POSITION ADJUSTMENT

The collector rings should face the brushes. The hub should be positioned 27/64" to 29/64" from the end of the shaft. To adjust, locate the governor on the shaft.

(68.3) MOTOR GOVERNOR BRUSH SPRING ADJUSTMENT

Each brush should rest against the governor ring with a pressure of 2-1/2 to 3-1/2 ozs. To adjust, bend the brush springs. After adjusting, the brushes should lie flat against the rings.

(68.4) FAN POSITION ADJUSTMENT

The fan should be located on the shaft so that the fan hub rests against the governor hub, and so that the line scribed on the periphery of the fan lines up, within 1/16", with the white line on the periphery of the governor. To adjust, locate the fan, and tighten the set screws.

(68.5) SPEED ADJUSTMENT

To adjust the motor speed, turn the governor contact screw which is located inside the hole in the motor fan. Insert a small screw driver through the hole and turn the screw inward to increase the speed, and outward to decrease the speed.

Paragraph 2.a.(70) Page 3-8  
Delete this paragraph.

Paragraph 2.b.(1) Page 3-8  
Add the following adjustment immediately prior to Paragraph 2.b.(1):

(.1) MOUNTING PLATE ADJUSTMENT - PRELIMINARY

Position the end-of-line indicator plate by means of its three mounting screws so that the feed pawl lever fully engages a tooth of the ratchet wheel. This engagement must occur with the ratchet wheel in its fully returned position and the spacing cam follower on the high part of its cam.

Paragraph 2.b.(2) Page 3-8  
Immediately following this adjustment add:

With the CARRIAGE RETURN combination selected, both the check pawl and the feed pawl teeth should clear the teeth of the ratchet wheel by at least .010". See Figure 44.1. To adjust, loosen the end-of-line indicator mounting screws and take up the play in the mounting holes by moving the entire plate toward the front of the printer.

Paragraph 2.b.(13) Page 3-9  
Delete paragraph 2.b.(13) and substitute the following therefor:

Position the cam by means of the lock washer and securing nut so the contacts close on the sixty-fifth or sixty-sixth space following a carriage return-line feed selection.

Paragraph 3.a.(4) Page 3-10  
Change the last sentence to read as follows: To adjust, remove the locking loop spring and place the locking loop gauge number 120436\* between the locking loop blade and the locking levers. Bring the locking loop blade down to meet the locking loop gauge and tighten the screws.

Replace the spring and make sure that there is from .008" to .015" clearance between the locking loop blade and the locking levers.

\*Gauge should be ordered separately; it is not included in any set of parts.

Paragraph 3.a.(10) Page 3-10

Substitute this adjustment with the following: There should not be less than .140" travel for the number 5 code bar and the universal bar. To adjust, depress the letter "Q" key lever and hold it in position.

There should be some clearance, not more than .020" between the side of the key lever and the vertical sections of the number 5 code bar and universal bar. Position the left code bar guide roller bracket to obtain this clearance, while viewing the keyboard from the bottom.

To adjust the right-hand code bar guide roller bracket, depress the letter "L" key lever and measure the clearance in the manner outlined above.

Paragraph 3.a.(11) Page 3-10

Change this requirement from "1-3/4 to 2-1/2 ozs." to read: 1-1/4 to 2 ozs.

Paragraph 3.a.(12) Page 3-11

Delete this paragraph.

Paragraph 3.a.(14) Page 3-11

Add the following paragraph immediately after this paragraph:

(14.1) REAR KEY LEVER GUIDE ADJUSTMENT

There should be no interference between either the spacing bar key lever or the blank key lever and the left and right code bar guides. Check this clearance between the small guiding buttons on the code bar guide bracket and the adjacent key lever. To adjust, position the rear key lever guide or the rear key lever guide bracket.

Section IV, Paragraph 3.b.(1) Page 4-1

Change "Ratchet wheel shaft" to read: Ratchet wheel shaft bearing.

Section V, 3. Motor speed failure: Page 5-1

Delete the third sentence.

Section VI, Pages 6-1 to 6-3

Delete this section.

Section VII, Pages 7-1,2

Substitute Wiring Diagram WD-2591 for WD-2487.

Section VIII, Figure 3 Page 8-7

Substitute Figure 3 attached hereto for the Figure 3 on Page 8-7.

Figure 5 Page 8-8

Delete the .040" to .060" clearance.





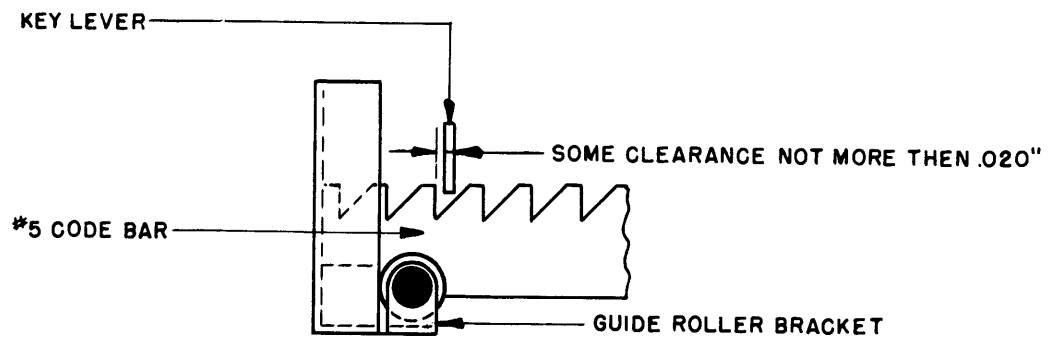

FIGURE 5.1

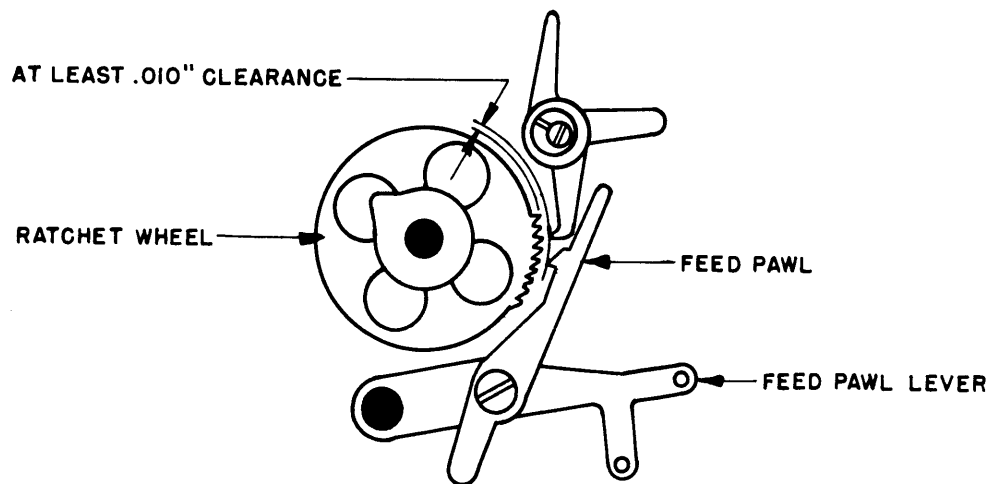

FIGURE 44.1

CHANGES AND ADDITIONS  
TO BULLETIN 200, ISSUE 1  
MODEL 31 TAPE PRINTER  
AS SUPPLIED ON  
NAVY CONTRACT NOa(S) 9217

SECTION III, Paragraph 2.a.(25)(a), Page 3-3

In the fifth line, change the word "marking" to read: spacing.

Paragraph 2.a.(25)(c), Page 3-3

Add to this requirement "To adjust, position the selector-magnet adjusting post."

Paragraph 2.a.(27), Page 3-3

In the first and second lines, change the "No. 1" to read: No. 2.

Delete the last sentence and substitute the following therefor: It should require from 1/4 to 3/4 oz. to start the numbers 1, 3, 4, 5 selector levers moving.

Paragraph 2.a.(35), Page 3-4

Immediately following this adjustment add: When making this adjustment, the eccentric stud must be in its lowest position for proper operation.

Paragraph 2.a.(69), Page 3-8

Delete this paragraph.

Paragraph 2.a.(70), Page 3-8

Delete this paragraph.

Paragraph 2.b., Page 3-8

Insert the following adjustment between paragraph 2.b. and paragraph 2.b.(1):

(.1) MOUNTING PLATE ADJUSTMENT - PRELIMINARY

Position the end-of-line indicator plate by means of its three mounting screws so that the feed pawl lever fully engages a tooth of the ratchet wheel. This engagement must occur with the ratchet wheel in its fully returned position and the spacing cam follower on the high part of its cam.

Paragraph 2.b.(2), Page 3-8

Immediately following this adjustment add:

With the CARRIAGE RETURN combination selected, both the check pawl and the feed pawl teeth should clear the teeth of the ratchet wheel by at least .010". See Figure 44.1. To adjust, loosen the end-of-line indicator mounting screws and take up the play in the mounting holes by moving the entire plate toward the front of the printer.

Paragraph 2.b.(13), Page 3-9

Delete paragraph 2.b.(13) and substitute the following therefor:  
Position the cam by means of the lock washer and securing nut so the contacts close on the sixty-fifth or sixty-sixth space following a carriage return-line feed selection.

Paragraph 3, Page 3-10

Insert the following instructions between paragraph 3 and paragraph 3.a:

ASSEMBLY INSTRUCTIONS FOR MOUNTING VIBRATION MOUNT ASSEMBLY TO MODEL 31  
KEYBOARD UNIT

Remove the right and left vibration mount skids from the assembly by loosening the wing nuts and the securing bushings. Dismount the clamping bars from the skids and lay them in the troughs of the base plate so that the mounting holes align with the holes in the base. Place the skids underneath the base plate and fasten them to the clamping bars with the four hexagonal screws. (Caution: Do not interchange right and left vibration mount skids.) After both skids have been assembled to the base plate, place the keyboard unit on the vibration mount assembly and position it with respect to the backstop pins.

Place the securing bushings over the forward extensions on the skids and draw them tight with the wing nuts. Make sure that the backstop pins engage the holes in the skids before tightening the wing nuts. Tighten the wing nuts until the lower lips on the shock mount skids rest securely against the right angle guide rails on the vibration mount assembly.

Paragraph 3.a.(4), Page 3-10

Change the last sentence to read as follows: To adjust, remove the locking loop spring and place the locking loop gauge number 120436\* between the locking loop blade and the locking levers. Bring the locking loop blade down to meet the locking loop gauge and tighten the screws. Replace the spring and make sure that there is from .008" to .015" clearance between the locking loop blade and the locking levers.

\*Gauge should be ordered separately; it is not included in any set of parts.

Paragraph 3.a.(10), Page 3-10

Substitute this adjustment with the following: There should not be less than .140" travel for the number 5 code bar and the universal bar. To adjust, depress the letter "Q" key lever and hold it in position.

There should be some clearance, not more than .020" between the side of the key lever and the vertical sections of the number 5 code bar and universal bar. Position the left code bar guide roller bracket to obtain this clearance, while viewing the keyboard from the bottom.

To adjust the right-hand code bar guide roller bracket, depress the letter "L" key lever and measure the clearance in the manner outlined above.

Paragraph 3.a.(11), Page 3-10

Change this requirement from "1-3/4 to 2-1/2 ozs." to read: 1-1/4 to 2 ozs.

Paragraph 3.a.(12), Page 3-11

Change the second sentence to read: Check by depressing the space bar at its midpoint.

Add the following paragraph to the end of paragraph 3.a.(12):

The release pawl should release the driving pawl when the space bar is depressed at its extreme ends.

Paragraph 3.a.(14), Page 3-11

Add the following after paragraph 3.a.(14):

#### (14.1) REAR KEY LEVER GUIDE ADJUSTMENT

There should be no interference between either the spacing bar key lever or the blank key lever and the left and right code bar guides. Check this clearance between the small guiding buttons on the code bar guide bracket and the adjacent key lever. To adjust, position the rear key lever guide or the rear key lever guide bracket.

Paragraph 3.a.(15), Page 3-11

Add the following after paragraph 3.a.(15):

### 4. DYNAMOTOR UNIT

#### a. PRELIMINARY ADJUSTING PROCEDURE

##### (1) MOTOR GOVERNOR BRUSH SPRING ADJUSTMENT

Each brush should rest against the governor ring with a pressure of 2-1/2 to 3-1/2 ozs. To adjust, bend the off-set portion of the brush springs. After adjustment, the brushes should lie flat against the rings. See Figure 49.

##### (2) GOVERNOR POSITION ADJUSTMENT

The position of the centrifugal governor assembly should be 27/64" to 29/64" from the end bell of the motor. Adjust by means of the two set screws. See Figure 49.

##### (3) FAN POSITION ADJUSTMENT

The scribed line on the motor fan should line up with the white line on the circumference of the governor assembly. To adjust, locate the fan and tighten the two set screws in the hub of the fan. See Figure 50.

##### (4) SLIDING TERMINAL POSITION

The sliding terminal of the 100 ohm variable resistor, located on the right side of the dynamotor speed control unit, should be positioned as close to the wired terminal of the resistor as possible. This is a

position of minimum or zero resistance. To adjust, position the sliding terminal. See Figure 51.

#### (5) MOTOR POSITION ADJUSTMENT

There should be a perceptible amount of backlash between the motor pinion and its gear. Check throughout one complete revolution of the larger gear. To adjust, position the motor mounting bracket by means of its four mounting screws. See Figure 2.

#### (6) INSERTING THE MILLIAMMETER

If a tube adapter type plug is not available break the plate lead of the 25L6GT tube. Then insert a milliammeter.

#### b. CLUTCH TORQUE, LINE, AND DYNAMOTOR LOAD ADJUSTMENTS

(1) Connect line cord to 115V D.C. supply and adjust to .020 amperes.

(2) Connect .070 ampere load to dynamotor output using terminals 3 and 1. A suitable load would be a variable resistor 3-4000 ohms having a power rating of at least 25 watts.

#### CAUTION

Terminal 3 has +250 volts.

(3) Connect the power cords to (26-1/2 volts) and allow the motor to warm up.

(4) With the main shaft running at least 10 minutes, hook a 32 oz. scale over the tip of the projection on the stop disc at a right angle to the radius. It should require 18 to 22 ozs. to hold the stop disc stationary. Adjust by means of the clutch spring adjusting nuts. This adjustment should be checked repeatedly throughout the speed setting of the motor.

#### c. SETTING OF DYNAMOTOR SPEED

(1) After the input voltage, clutch torque, load and line current have been checked, adjust the speed.

(a) Recheck the input voltage and adjust it to 26-1/2 volts  $\pm$  .25 volt. The motor should rotate at 7008 r.p.m. as viewed with an 87.6 VPM fork with indicated plate current of .017 to .020 amperes and the selector armature in the marking position. Under this condition the three black spots on the fan will appear stationary. To obtain correct speed, insert a small screwdriver through a hole in the periphery of the fan and adjust the governor contact adjusting screw. To increase the speed, turn the screw clockwise. To decrease the speed, turn the screw counterclockwise. See Figure 50.

(b) If the value of plate current is high, adjust the taps on the 3/4 ohm resistor to add the necessary resistance. First, cut the strap on the resistor. This will insert .25 ohms. If this is not sufficient

resistance, unsolder the green lead and refasten it at the extreme end of the resistor. This will insert .50 ohm. The full 3/4 ohm resistor may be added by unsoldering the white lead and refastening it to the position originally occupied by the green lead. See Figure 51.

(c) If the value of the plate current is low, adjust the slider on the 100 ohm resistor toward the unwired terminal. Recheck the input voltage load, and then measure the output voltage. The output voltage should be 250 volts. See Figure 51.

(d) The speed of the dynamotor should be within  $\pm 1\%$  of 7008 r.p.m. under the following conditions: CAUTION: Do not reset .070 ampere load when operating at either voltage extreme.

1. Input voltage lowered to 25 volts  $\pm .25$  volt and the selector armature in the MARKING position.

2. Input voltage raised to 29-1/2 volts  $\pm .25$  volt and the selector armature in the SPACING position.

3. If these two conditions cannot be met, position the variable 100 ohm resistor. Move the slider toward the unwired terminal to increase speed and toward the wired terminal to decrease speed. Whenever an adjustment of this resistor is made a recheck of the governor setting must be made at 26-1/2 volts  $\pm .25$  volt. Then go back to either the high or low voltage setting and recheck the speed.

(e) If speed checks are made at other than normal or room temperatures lubricate the parts in accordance with SECTION IV.

#### 5. TAPE REEL ADJUSTMENT Figure 48

With the tape reel plate fully detented, there should be some clearance between the lip of the tape reel clip and the outside diameter of the tape roll. To adjust, loosen the two plate holding screws and detent the tape reel plate in the clip. Position the tape reel clip so that the tape reel plate edge closest to the cover is 1/2" to 5/8" from the inner wall of the cover. Measure this requirement while viewing the detented portion of the tape reel plate from the bottom of the cover. Slide the tape reel clip towards the rear wall of the cover as far as possible. Recheck previous adjustment and then tighten plate holding screws.

SECTION IV, Paragraph 3.b.(1), Page 4-1

Change "Ratchet wheel shaft" to read: Ratchet wheel shaft bearing.

SECTION VI, Pages 6-1 to 6-3, inclusive

Substitute the 116500 spare parts list attached hereto for the 106949 spare parts list.

SECTION VII, Pages 7-1,2

Substitute Wiring Diagram WD-2584 attached hereto for WD-2487.

SECTION VIII, Figure 3, Page 8-7

Substitute Figure 3 attached hereto for the Figure 3 on Page 8-7.

Figure 5, Page 8-8

Delete the .040" to .060" clearance.

Insert Figure 5.1 attached hereto immediately after Figure 5.

Figure 30, Page 8-19

Change the sixth item in the left-hand column from "1/2 to 1 oz."  
to read: 1/2 to 1 oz. for No. 2

1/4 to 3/4 oz. for Nos. 1, 3, 4, 5

Figure 44, Page 8-25

Insert Figure 44.1 attached hereto immediately after Figure 44.

Figure 47, Page 8-26

Add Figures 48, 49, 50, and 51 attached hereto immediately after  
Figure 47.

\* \* \*

(EE-675)

116500 SPARE PARTS KIT FOR  
MODEL 31 TAPE PRINTER

<u>Quantity</u>	<u>Part Number</u>	<u>Description</u>
1	36-73	Pin
1	138-34	Wrench - 1/4" open
1	138-55	8 oz. Scale
1	138-58	2 lb. Scale
2	M-243	Coil - Selector
3	1026	Screw 6-40 x 3/8 Fil.
3	1160	Screw 6-40 x 5/16 Fil. HD.
9	2191	Lock Washer
1	3598	Nut 6-40 Hex.
1	3608	Spring - Tension
1	7002	Washer
2	8543	Screw 6-40 x 1/4 Fil.
4	41733	Insulator
1	72003	Contact Bender
1	75503	Spring Hook - Push
1	75765	Spring Hook - Pull
4	78398	Bushing
1	82711	4 lb. Scale
1	88993	Contact Burnisher
1	91117	Contact File
1	95936	Choke Coil 1.1 Ohm
1	95937	Condenser .01 mf.
1	95938	Condenser 1 mf.
1	97116	KS-7470 Grease
1	109034	Screw - Shoulder
1	116404	Gear 50T
1	116406	Gear 25T
1	116407	Gear 48T - 60 WPM
1	116409	Gear 47T
1	116410	Pinion 11T
1	116629	Type Sector
1	116667	Governor - Lee
1	116668	Cap - Green
1	116669	Cap - Red
2	116698	Lamp - 6V Mazda #47
1	116699	Lamp - Neon NE-51
1	117781	Gauge Kit
4	119777	Dynamotor Brush - 26.5 V
4	119778	Dynamotor Brush - 250 V
4	120372	Governor Brush
1	120384-G	Electron Tube





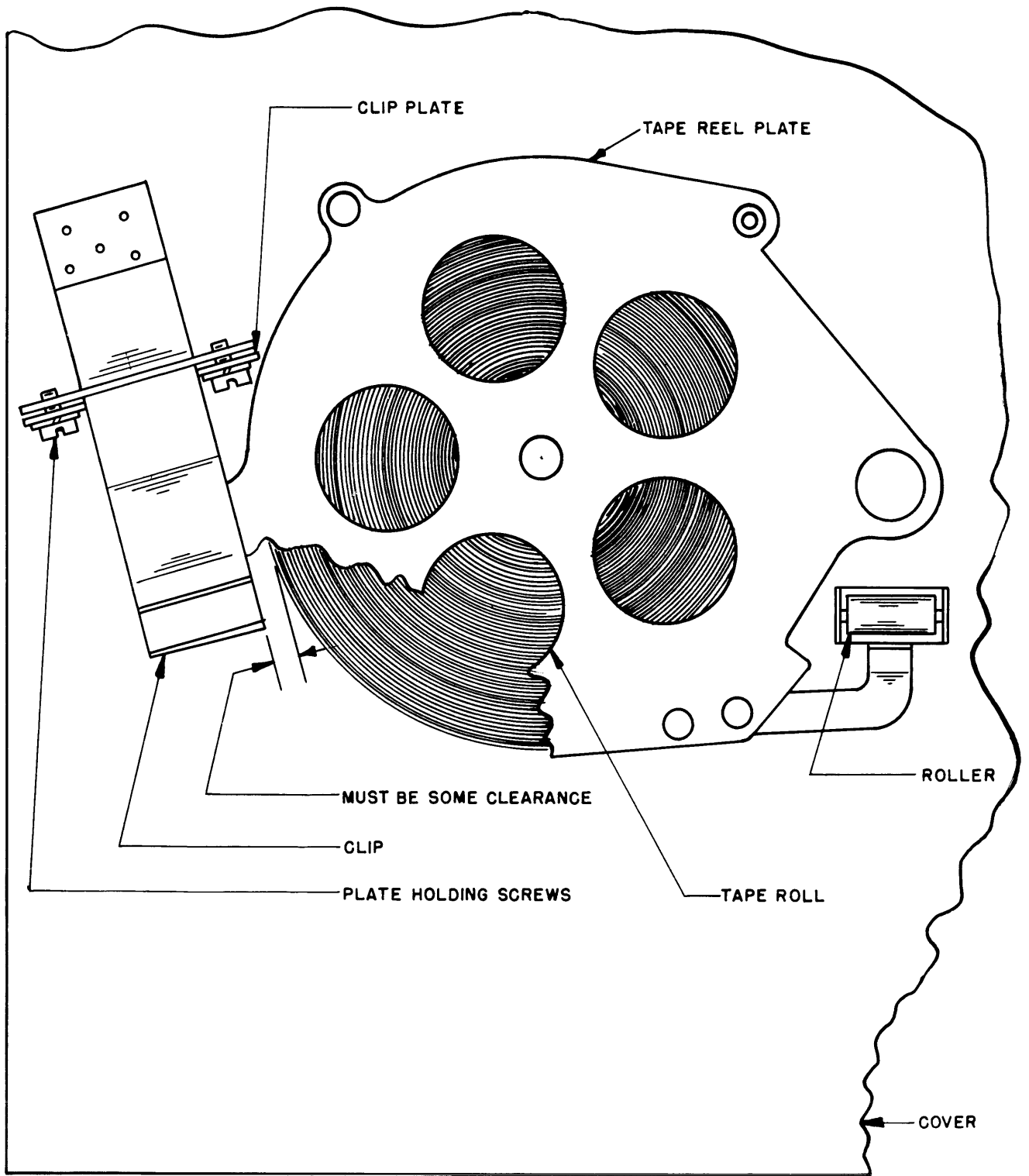

FIGURE 48

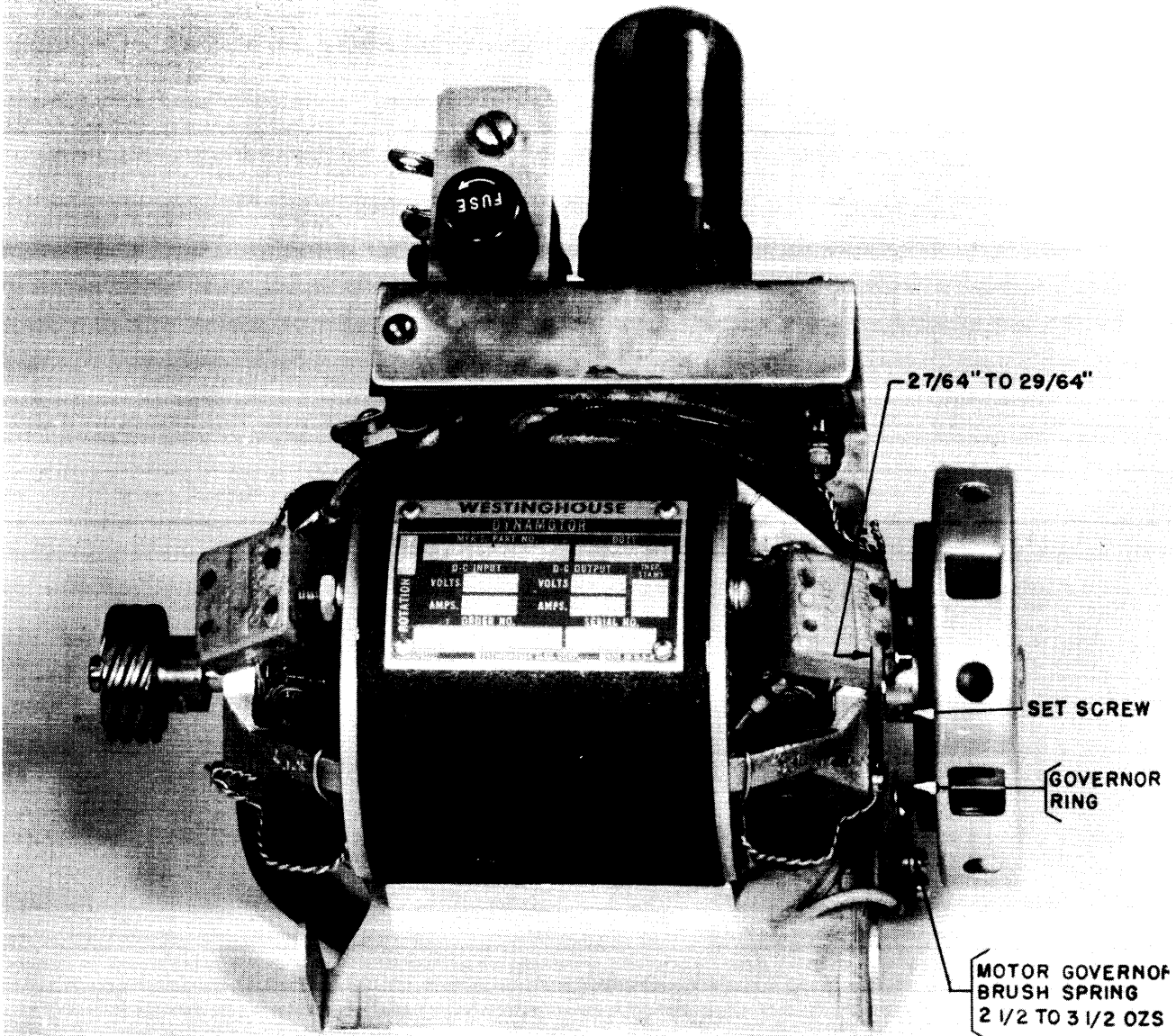

FIGURE 49

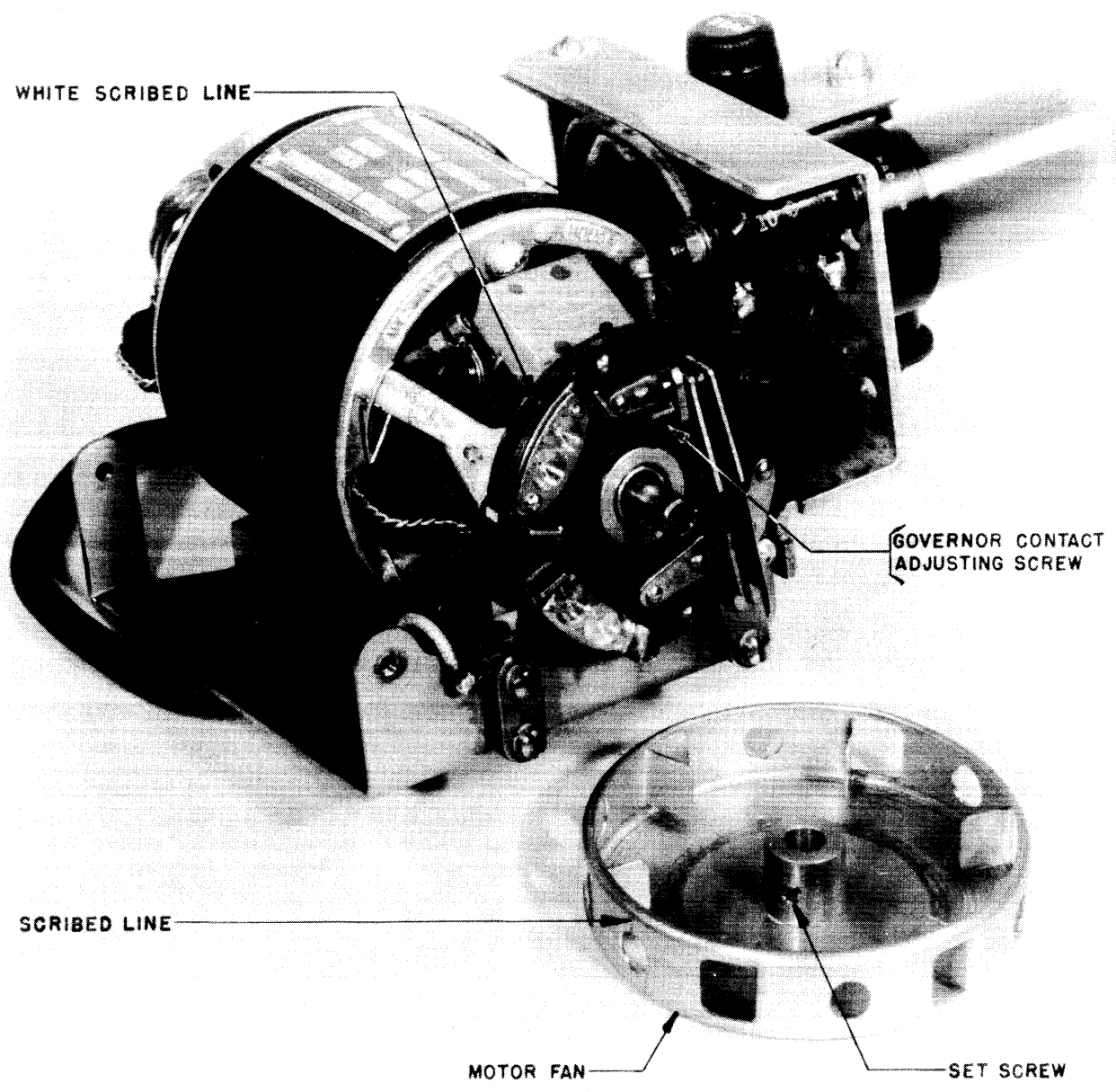
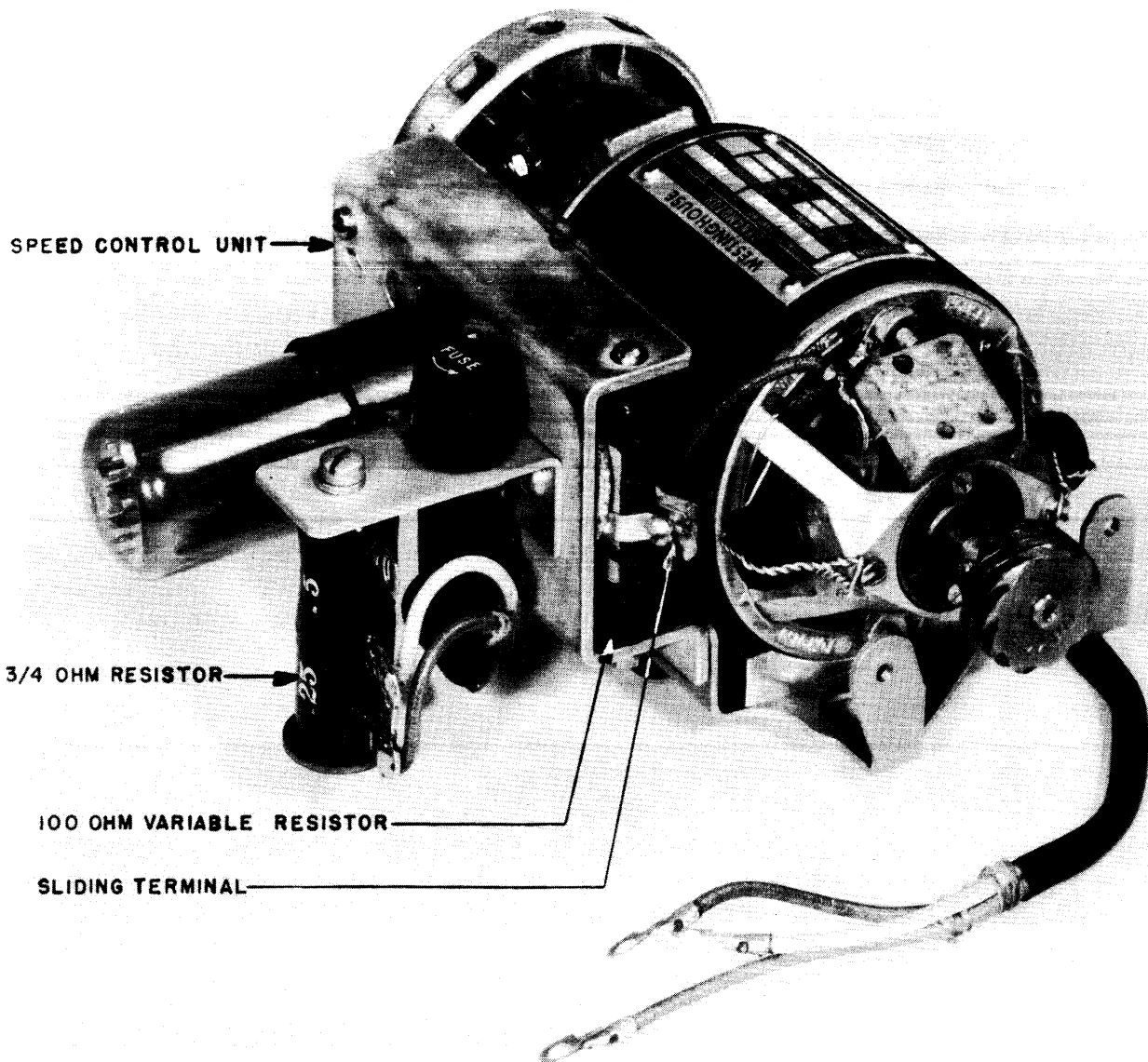

FIGURE 50



SPEED CONTROL UNIT

3/4 OHM RESISTOR

100 OHM VARIABLE RESISTOR

SLIDING TERMINAL

FIGURE 51

NO.	NOTES												
1.	<p>WIRE COLOR CODE &amp; SYMBOLS MAY BE SOLID COLOR OR TRACERS IN WHITE WIRE:</p> <table border="0"> <tr> <td>Y YELLOW</td> <td>W WHITE</td> </tr> <tr> <td>G GREEN</td> <td>O ORANGE</td> </tr> <tr> <td>BR BROWN</td> <td>S SLATE</td> </tr> <tr> <td>P PURPLE (RED AND BLUE TRACER)</td> <td>R RED</td> </tr> <tr> <td></td> <td>BK BLACK</td> </tr> <tr> <td></td> <td>BL BLUE</td> </tr> </table> <p>* DENOTES SPLICE &amp; TAPE WIRE.</p>	Y YELLOW	W WHITE	G GREEN	O ORANGE	BR BROWN	S SLATE	P PURPLE (RED AND BLUE TRACER)	R RED		BK BLACK		BL BLUE
Y YELLOW	W WHITE												
G GREEN	O ORANGE												
BR BROWN	S SLATE												
P PURPLE (RED AND BLUE TRACER)	R RED												
	BK BLACK												
	BL BLUE												
2.	<p>ASSOCIATED CABLES:</p> <table border="0"> <tr> <td>—————</td> <td>120008 KEYBOARD</td> </tr> <tr> <td>-----</td> <td>120009 MOTOR</td> </tr> <tr> <td>-----</td> <td>120010 END-OF-LINE INDICATOR</td> </tr> <tr> <td>-----</td> <td>120011 SELECTOR MAGNET</td> </tr> </table>	—————	120008 KEYBOARD	-----	120009 MOTOR	-----	120010 END-OF-LINE INDICATOR	-----	120011 SELECTOR MAGNET				
—————	120008 KEYBOARD												
-----	120009 MOTOR												
-----	120010 END-OF-LINE INDICATOR												
-----	120011 SELECTOR MAGNET												
3.	<p>SELECTOR COILS</p> <table border="1"> <thead> <tr> <th>CURRENT- AMPS.</th> <th>RESISTANCE-OHMS</th> </tr> </thead> <tbody> <tr> <td>.020</td> <td>950 EACH</td> </tr> </tbody> </table>	CURRENT- AMPS.	RESISTANCE-OHMS	.020	950 EACH								
CURRENT- AMPS.	RESISTANCE-OHMS												
.020	950 EACH												
4.	<p>5.8 MICROHENRIES 0.028 OHMS 1.5 MFD.</p>												

5 \* PLACE VINYL TUBING OVER ALL TERMINALS WITH ASTERISK.

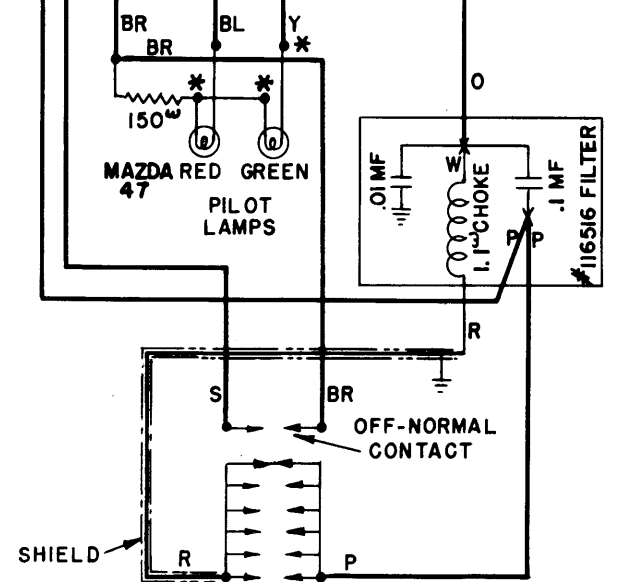
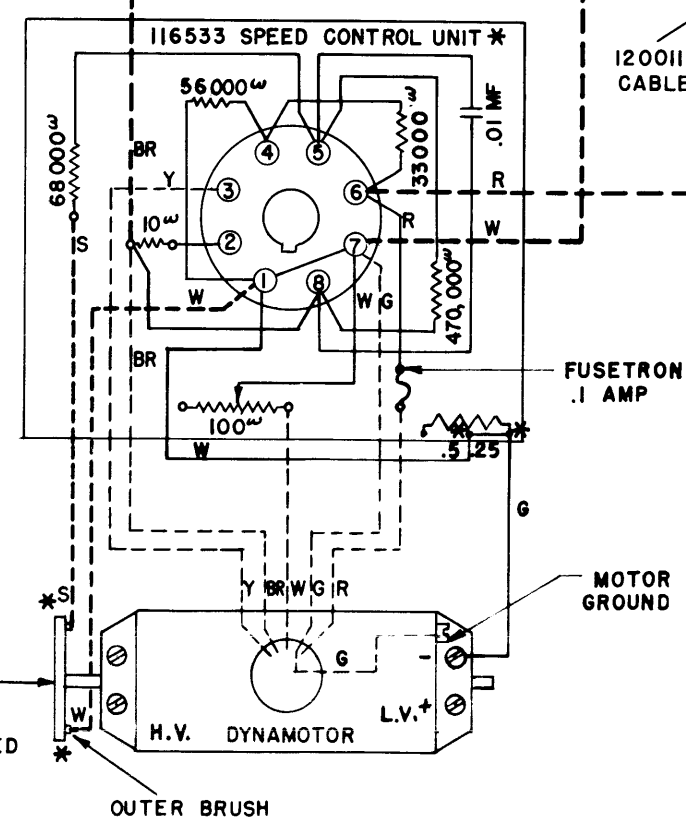
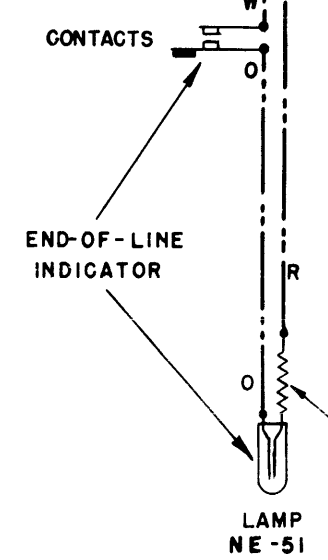
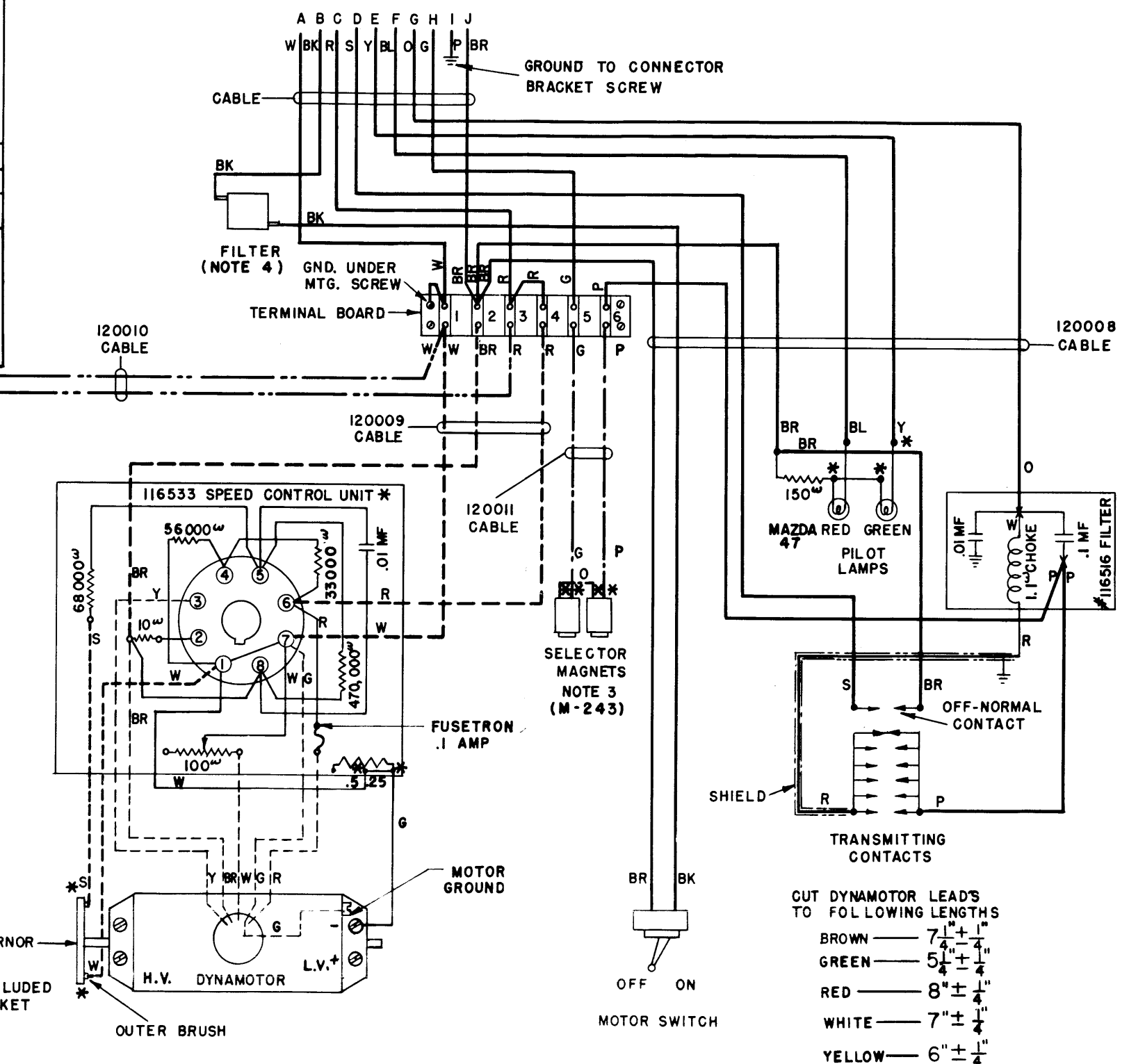
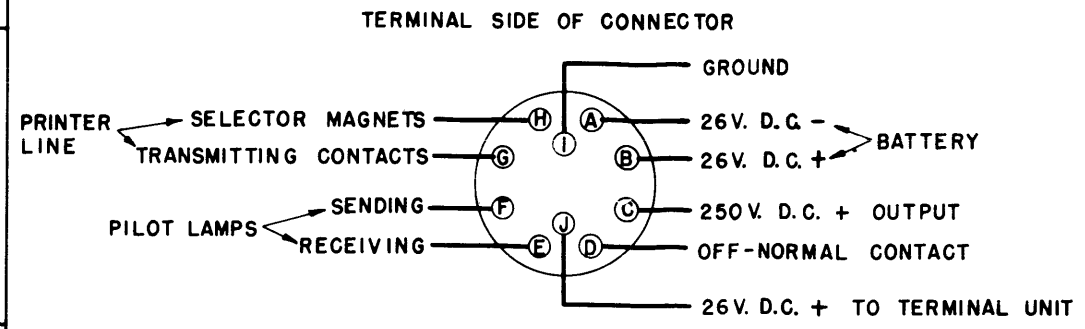

- TRANSMITTING CONTACTS
- CUT DYNAMOTOR LEADS TO FOLLOWING LENGTHS
- BROWN — 7 1/4" ± 1/4"
  - GREEN — 5 1/4" ± 1/4"
  - RED — 8" ± 1/4"
  - WHITE — 7" ± 1/4"
  - YELLOW — 6" ± 1/4"

REVISIONS		
A	12-27-48	46304
B	1-25-49	46560
C	2-22-49	46819
D	3-30-49	47077
E	4-29-49	47359

**WD-2584-E**  
12-1-48

**WIRING DIAGRAM**  
MODEL 31 PRINTER

TYPING UNIT: KP 3  
KEYBOARD: KK 201  
MOTOR ARRANGEMENT: JB

DRAWN: G.A.R. APPROVED: *FR*  
ENGR'D: *JBL*  
CHECKED: *SW*  
FILE: 1-30.87AA

**TELETYPE CORPORATION**

\* SEE DRAWING 116533 FOR MANUFACTURING RESTRICTION.

NOTE: COVER KEYBOARD CABLE WITH PLASTIC TAPE WHENEVER FORMED AROUND METAL EDGES AND LACE CABLE TO REAR TRANSMITTING SHIELD POST.

CORRECTIONS AND ADDITIONS TO  
BULLETIN 200, ISSUE 1  
MODEL 31 TAPE PRINTER

PAGE 3-2  
Section III, Paragraph 2.a.(12)

In the first line at the top of page 3-2, after the word "cam", add the following words: and the armature extension in the marking position-----.

PAGE 3-10  
Paragraph 3.a.(4)

Delete the second sentence in paragraph 3.a.(4) which reads -  
"The clearance at No. 1 and No. 5 levers should be equal within .005".

\* \* \*