

Form 64
May 1979
Revision A August 1979
Revision B January 1980
Revision C August 1981

BIT PAD ONE
USERS MANUAL
BY
SUMMAGRAPHS CORPORATION

The contents of this manual are proprietary to Summagraphics Corporation and may not be reproduced or copied in any form without the permission of Summagraphics Corporation.

ADDENDUM B

to

Bit Pad One Users Manual

FORM 64

This addendum is cumulative for all addenda issued to this publication. It identifies all page changes and the dates they were issued.

| <u>PAGE NUMBER</u> | <u>CHANGE DATE</u> |
|--------------------|--------------------|
| 3 | 7/30/82 |
| 4 | 7/30/82, 8/17/82 |
| 6 | 7/30/82 |

BB/gmm (0334-26)

ADDENDUM C

to

Bit Pad One Users Manual

FORM 64

This addendum is cumulative for all addenda issued to this publication. It identifies all page changes and the dates they were issued.

| <u>PAGE NUMBER</u> | <u>CHANGE DATE</u> |
|--------------------|--------------------|
| 11 | 2/11/83 |
| 3 | 7/30/82 |
| 4 | 7/30/82, 8/17/82 |
| 6 | 7/30/82 |

WARRANTY

SUMMAGRAPHS warrants to the original purchaser that this equipment, including its components and parts, shall be free from defects in material and workmanship for a period of (90) days from the date of shipment. SUMMAGRAPHS' obligation under this warranty shall be limited to repair or replacement, at the option of SUMMAGRAPHS, Fairfield, Connecticut. Return of a repaired instrument shall be f.o.b. SUMMAGRAPHS, Fairfield, Connecticut. The above warranty is contingent upon normal usage and does not cover products which have been modified without SUMMAGRAPHS' approval or which have been subjected to unusual physical or electrical stress or on which the original identification marks have been removed or altered. The above warranty will not apply if adjustment, repair or parts replacement is required because of accident, neglect, misuse, failure of electric power air-conditioning, humidity control, transportation or causes other than normal and ordinary usage. To the extent that any of its equipment is furnished by a manufacturer other than SUMMAGRAPHS, the foregoing warranty shall be applicable only to the extent of the warranty furnished by such other manufacturer. This warranty will not apply to appearance terms, such as knobs, handles, dials or the like, nor to the pen cartridge or refills of the pen cartridge.

"THERE ARE NO WARRANTIES WHICH EXTEND BEYOND THE DESCRIPTION ON THE FACE HEREOF. The foregoing obligations are in lieu of all obligations and liabilities, including all warranties of implied or statutory, and state SUMMAGRAPHS' entire and exclusive liability and Purchaser's exclusive remedy for any claim of damages in connection with the sale or furnishing of all equipment, including design, suitability for use, operation or installation. In no event shall SUMMAGRAPHS be liable for any special or consequential damages."

January 1979

"WARNING: This equipment has been certified to comply with the limits for a Class B computing device, pursuant to Subpart J of Part 15 of FCC Rules. Only peripherals (computer input/output devices) certified to comply with the Class B limits may be attached to this computer. Operation with non-certified peripherals is likely to result in interference to radio and TV reception."

"This equipment generates and uses radio frequency and if not installed and used properly, that is, in strict accordance with the manufacturer's instructions, may cause interference to radio and television reception. It has been tested and found to comply with the limits for a Class B computing device in accordance with the specifications in Subpart J of Part 15 of FCC Rules, which are designed to provide reasonable protection against such interference in a residential installation. However, there is no guarantee that interference will not occur in a particular installation. If this equipment does not cause interference to radio and television reception, which can be determined by turning the equipment off and on, the user is encouraged to try to correct the interference by one or more of the following measures:

- Reorient the receiving antenna
- Relocate the computer with respect to the receiver
- Move the computer away from the receiver
- Plug the computer into a different outlet so that computer and receiver are on different branch circuits

If necessary, the user should consult the dealer or an experienced radio/television technician for additional suggestions. The user may find the following booklet prepared by the Federal Communications Commission helpful:

"How to Identify and Resolve Radio-TV Interference Problems."

This booklet is available from the U.S. Government Printing Office, Washington, D.C. 20402, Stock NO. 004-00-00345-4.

Accessories and optional equipment should be purchased from Summagraphics to insure compliance of the Class B emission limits.

TABLE OF CONTENTS

| <u>SECTION</u> | <u>TOPIC</u> | <u>PARAGRAPH</u> | <u>PAGE</u> |
|---|---|---------------------------|-------------|
| 1 | <u>General Description</u> | 1 | 3 |
| | General | A | 3 |
| | Operating Modes | B | 3 |
| | Interfaces | C | 3 |
| | <u>Theory of Operation</u> | 2 | 4 |
| | <u>Accessories & Optional Equipment</u> | 3 | 4 |
| 2 | <u>Set Up Procedures</u> | 1 | |
| | Unpacking | A | 5 |
| | Biasing | B | 5 |
| | Power Requirements | C | 6 |
| | Power-Up Conditions | D | 7 |
| | Strappable Options & Switch Settings | E | 7 |
| | 3 | <u>Modes of Operation</u> | 1 |
| <u>RS-232 Interface</u> | | 2 | 9 |
| General | | A | 9 |
| ASCII Data Format (Switch 1 Position 7 OFF) | | B | 9 |
| Remote Control Via RS-232 | | C | 11 |
| Cables and Connectors | | D | 12 |
| RS232 Unit Switch Settings and Strap Options for 600 Series Proms | | E | 12 |
| <u>IEEE Interface</u> | | 3 | 15 |
| General | | A | 15 |
| Data Format | | B | 15 |
| Remote Control | | C | 16 |
| Output Connector | | D | 16 |
| Cables | | E | 16 |
| Pin Assignments | | F | 17 |
| IEEE Unit Switch Settings for 400 Series Proms | | G | 17 |
| Sample IEEE Programs | | H | 19 |
| Hewlett Packard HPIB Sample Program | | 1 | 19 |
| Tektronix 4051 Sample Program | | 2 | 20 |
| <u>Parallel Interface</u> | | 4 | 21 |
| General | | A | 21 |
| Parallel Binary | | B | 21 |
| Parallel Binary Format | | C | 21 |
| Parallel BCD | | D | 22 |
| Parallel Remote Control | | E | 23 |
| Output Connector | | F | 25 |
| Parallel Unit Switch Settings and Strap Options for 500 Series Proms | | G | 26 |

TABLE OF CONTENTS

(Continued)

| <u>SECTION</u> | <u>TOPIC</u> | <u>PARAGRAPH</u> | <u>PAGE</u> |
|----------------|---|------------------|-------------|
| 4 | <u>Maintenance</u> | 1 | 28 |
| | Internal Diagnostics | A | 28 |
| | <u>Calibration</u> | 2 | 28 |
| | <u>Stylus Refill Replacement</u> | 3 | 30 |
| 5 | <u>Bit Pad One Drawings</u> | | 31 |
| | RS232/Parallel Logic Diagram (06-0011 Sheet 1 of 3) | | 32 |
| | RS232 Option (06-0011 Sheet 2 of 3) | | 33 |
| | Parallel Option (06-0011 Sheet 3 of 3) | | 34 |
| | IEEE Logic Diagram (06-0005 Sheet 1 of 2) | | 35 |
| | IEEE Option (06-005 Sheet 2 of 2) | | 36 |
| | Timing Diagram Parallel | | 37 |
| | Bit Pad One RS232 Outline Drawing | | 38 |
| | Bit Pad One IEEE Outline Drawing | | 39 |
| | Bit Pad One Parallel Outline Drawing | | 40 |

BIT PAD ONE

IMPORTANT NOTICE

Please read this manual carefully before using the Bit Pad One. Particular attention should be given to the unpacking instructions and storage instructions for the biasing device in Section 2.

1. GENERAL DESCRIPTIONA. General

Bit Pad One converts graphic information into digital form suitable for entry into a computer. By merely touching the pen-like stylus to any position on a map, diagram, menu or other graphic presentation, the coordinates of that position are transformed into their digital equivalents. The user may select a marking ball point stylus, a dry non-marking stylus, or a one, four or thirteen button cursor with crosshair sight to digitize with the Bit Pad One.

B. Operating Modes

Bit Pad One modes and sampling rate may be controlled externally under program control, or internally by switches on the logic board. Both the mode and sampling rate at power up are determined by positions of the internal switch; during operation they can be changed under program control from the host computer. The following modes are available:

Point Mode--Depression of the stylus on the tablet, or pressing a button on the cursor causes one X, Y coordinate pair (sample) to be output in the appropriate format.

Stream Mode--X, Y coordinate pairs (samples) are generated continuously at the selected sampling rate when the stylus or cursor is in the proximity of the active area of the tablet. Pressing the stylus to the tablet, or depressing a button on the cursor marks the flag character (F) bit in the output string.

Switch Stream Mode--Depression of the stylus, or pressing a button on the cursor causes X, Y coordinate pairs (samples) to be output continuously at the selected sampling rate until the stylus is lifted or cursor button released.

C. Interfaces

Bit Pad One is available with a choice of three output interfaces; RS232, Eight-Bit Parallel and IEEE-488.

RS232--This interface conforms with the EIA specification for RS232. Transmission is asynchronous, using USASCII seven bit code with strappable options for parity and number of stop bits. Serial data is either TTL or bipolar RS232 compatible. The Bit Pad One is considered a terminal which is transmitting to a modem with switch selectable rate up to 19,200 baud.

IEEE--This interface conforms to IEEE-488-1975 Digital Interface for Programmable Instrumentation standard. Several formats are switch selectable for GPIB (including Tektronix), HPIB (Hewlett

Packard) and Commodore Pet. The device address is switch selectable. The data transfer rate can be a maximum of 125 coordinates per second, depending on the receiving device.

Eight Bit Parallel--Within this interface, two formats, Binary and Binary Coded Decimal (BCD) are switch selectable. In the binary format, five eight-bit bytes are output for each coordinate pair. In the BCD mode, twelve ASCII BCD characters are output for each coordinate pair. The data transfer rate may be a maximum of 200 coordinate pairs per second, depending on the receiving device. The BCD interface is specifically designed to permit the Bit Pad One to be plugged into the Remote Keyboard port on a CRT or micro-computer.

2. THEORY OF OPERATION

The Summagraphics Bit Pad One operates on the magnetostrictive principle. Current is pulsed along a send wire that lies perpendicular to a mesh of magnetostrictive wires laid on a substrate beneath the tablet writing surface. This current pulse changes the dimensions of the magnetostrictive material and a strain wave propagates down all the wires of the axis in one direction simultaneously. The stylus and cursor have "receive" coils in them and sense the passing of the strain wave. The binary counter in the control unit is used to time the delay required for the strain wave to reach the receive coil. This binary count is then formatted by the microprocessor and output as X and Y coordinate data.

3. ACCESSORIES & OPTIONAL EQUIPMENT

| | |
|---|-------------------------|
| <u>Bit Pad One</u> --RS232 | Part Number 01-0015-002 |
| IEEE | Part Number 01-0017-002 |
| Parallel | Part Number 01-0016-002 |
| Stylus with blue and dry (non-marking) refills, Operator's Manual and Mating Power Connector. | - 01-0093-016 |

Optional Accessories

| | |
|--|------------------------|
| Power Supply (with regulator, cable and power connector) | |
| standard USA model, 105 to 130V, 57 to 63Hz | 36-0090-001 (PS-1) |
| standard international model, 210 to 250V, 48 to 52Hz | 36-0090-002 (PS-2) |
| heavy-duty model (required for Mexico, Japan) 115V Nominal - range suitable for Mexico and Japan, 47 to 63Hz | 01-0019-001 (PS-3) |
| heavy-duty model 220V, 47 to 63Hz | 01-0019-002 (PS-4) |
| Cursor | |
| One Button | C01-0090-021 |
| Four Button | C01-0091-023 |
| Thirteen Button | 01-0118-003 |
| Data Interface Cables | |
| Parallel and RS232 | 05-0079-001 (10 ft.) |
| IEEE | 78-6001-001 (2 meters) |

1. SET UP PROCEDURESA. Unpacking

Visually inspect the Bit Pad One package for any signs of physical damage. If any damage is found, do not open the package, contact the carrier immediately. When unpacking, it will be noted that a semi-flexible rubber-base magnet is carefully packaged with the controller and tablet. Please maintain a separation between magnet and tablet in your working area. Do not allow the magnet to rest on top of or near the tablet, except under the controlled conditions described in the tablet biasing section of this manual.

After the system is unpacked and before initial operation, please read the following sections of the manual and immediately follow the instructions for the tablet, referring to the figure on the page for a visual demonstration of the biasing procedure.

B. Biasing

It will be necessary to magnetically bias your Bit Pad One tablet after unpacking. A magnet has been provided for this purpose.

It is very unlikely that the tablet will ever need to be biased again. In case any magnetic materials are laid on the tablet, rebiasing may be necessary. If you discover "holes" or "dead-sports" in the active area, rebiasing should be done.

Please be careful to store the biasing magnet away from the Bit Pad and away from all your magnetic diskettes, tapes or cassettes.

TABLET WIPING INSTRUCTIONS

HOLD MAGNET AS SHOWN IN DRAWING. (ARROWS ON LABEL MUST POINT FORWARD - LABEL SIDE OF MAGNET UP). HOLD MAGNET FIRMLY AGAINST SURFACE OF TABLET - WIPE DIAGONALLY FROM UPPER LEFT TO LOWER RIGHT. WIPING MUST BE DONE SLOWLY IN ONE CONTINUOUS MOTION.

TABLET CABLE

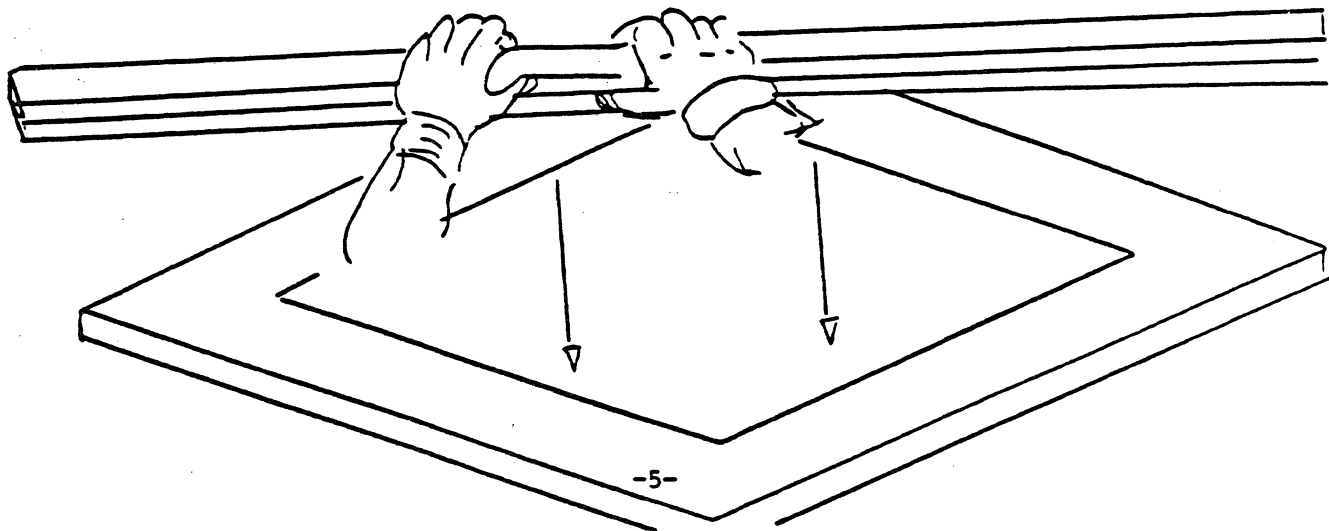
DO NOT STORE MAGNET NEAR TABLET.

C. Power requirements

The following power requirements must be met to insure proper operation of the Bit Pad One:

External Power Requirements
(Regulated)

| | PARALLEL | RS232 | IEEE |
|--------|----------|-------|-------|
| -12VDC | 70mA | 70mA | 60mA |
| +12VDC | 90mA | 110mA | 80mA |
| + 5VDC | 500mA | 500MA | 750mA |

Ripple Specification

Maximum ripple 15mV RMS, 50mVpp Maximum
50mV RMS

Every Bit Pad One is shipped with a connector which will mate with the power input connector located at the rear of the unit. The following pin assignments apply to this connector:

CAUTION

PLEASE NOTE PIN REVERSAL FROM CABLE TO PC BOARD

Power Input
Cable Connector (P2)

1 Spare
2 Spare (Key)
3 - 12 Volts \pm 5%
4 + 12 Volts \pm 5%
5 + 5 Volts \pm 5%
6 + 5 Volts \pm 5%
7 Ground

Power
Cable
Connector

| | |
|---------|---------|
| 1 | 7 |
| 2 (Key) | 6 (Key) |
| 3 | 5 |
| 4 | 4 |
| 5 | 3 |
| 6 | 2 |
| 7 | 1 |

PC
Board
Pins

D. Power-Up Conditions

The Bit Pad One will default to a particular power-up condition based on the switch settings (on internal switch 2) or front panel switch settings for mode and rate.

Information on setting these switches is supplied in Section 3-Operation. In addition to mode and rate, several other parameters will be set dependent on the interface used in a particular Bit Pad One. Each of the three parameters will be addressed for the appropriate interface in Section 3 of this manual.

E. Strappable Options & Switch Settings

The following switch settings are preset at the factory. Please refer to Section 3 and to the appropriate Interface paragraph if settings other than standard are desired.

| <u>Type of Unit</u> | <u>Standard Settings</u> |
|---------------------|---|
| All | Stream mode 200 coordinate pairs per second English |
| Parallel | Binary Data Output Positive Data Strobe Pulse |
| RS-232 | 9600 Baud Line Feed Even Parity Two Stop Bits |
| IEEE | Device 8 address No SRQ GPIB format (Tektronix) |

1. MODES OF OPERATION

Bit Pad One modes and sampling rate may be controlled externally under program control, or internally by switches on the logic board. The power-up mode and sampling rate are determined by the positions of the internal switch. Both the mode and sampling rate may be changed under program control from the host computer by sending the Bit Pad One either one ASCII character or eight bit byte, depending on the resident interface. The following modes are available:

Point Mode-- Depression of the stylus on the tablet, or pressing a button on the cursor causes one X, Y coordinate pair (sample) to be output in the appropriate format.

Stream Mode-- X, Y coordinate pairs (samples) are generated continuously at the selected sampling rate when the stylus or cursor is in the proximity of the active area of the tablet. Pressing the stylus to the tablet, or depressing a button on the cursor marks the flag character (F) bit in the output string.

Switch Stream Mode-- Depression of the stylus, or pressing a button on the cursor causes X, Y coordinate pairs (samples) to be output continuously at the selected sampling rate until the stylus is lifted or cursor button released.

Mode and Rate Controls--refer to Section 5, Bit Pad One Drawings for location of switches.

Each Bit Pad One has a 6 position switch which is used to set the mode of operation and the rate at which the coordinate data is output to the processor.

The Mode and Rate Controls on the standard Bit Pad One are mounted on SW 2. Positions 1 and 2 are mode switches and Positions 3, 4, and 5 are rate switches, Switch 6 is not used. The system reset switch is mounted externally on the lower frame.

2. RS232 INTERFACE

A. General

The Bit Pad One conforms to the EIA specification for asynchronous transmission. This means that each character is transmitted as a complete self-contained message consisting of a data character (ASCII) with even or odd parity (POE) preceded by a start bit and followed by one or two stop bits dependent on the strap option selected (HCB). The bit polarity of the transmitted data is low level mark, high level space in the following format:



The Bit Pad One asserts request to send (pin 4) and may be inhibited by the host using clear to send (pin 5). The Bit Pad One is considered a terminal and is configured to transmit or receive data to or from a modem. Direct connection to a processor may require reversal of the transmit and receive data lines.

B. ASCII Data Format (Switch 1 Position 7 OFF)

The serial interface that is available for the Bit Pad is an integral part of the Bit Pad printed circuit card. It outputs either serial data that is TTL compatible or serial data that is bipolar and RS232 compatible.

The output format for the serial data is: XXXX,YYYY,F CRLF*

*Switch Selectable

X is an ASCII BCD digit of the X coordinate 0000 to 2794 Metric, 0000 to 2200 English. (origin (0000) is in the lower left corner)

, is an ASCII comma.

Y is an ASCII BCD digit of the Y coordinate 0000 to 2794 Metric, 0000 to 2000 English.

F is an ASCII Hexadecimal digit which contains the Z Axis and flags data.

CR is an ASCII Carriage Return.

LR is an ASCII Line Feed (Switch Selected)

The format for the flag information ASCII character is:

| | | | | |
|--------------|----|----|----|-----|
| MSB | | | | LSB |
| ASCII Header | F3 | F2 | F1 | F0 |

ASCII Flag Characters Generated:

Stylus Switch

- Open ASCII "0"
- Closed ASCII "1"

4 Button Cursor

- No Flags Depressed ASCII "0"
- Flag 0 (Z axis) Depressed ASCII "1"
- Flag 1 Depressed ASCII "2"
- Flag 2 Depressed ASCII "4"
- Flag 3 Depressed ASCII "8"

Binary Data Format (Switch 1, Position 7 ON)

The Binary formatted RS-232 interface is a five byte output that is very much like the Binary Parallel Format. The advantage of the Binary Format over the ASCII format is the reduction of characters transmitted. Thirteen characters are reduced to five characters (a 50% increase in coordinates transmitted).

TABLE 3-1. BINARY FORMAT

| | Bit 7 | 6 | 5 | 4 | 3 | 2 | 1 | 0 |
|------|-------|---|-----|-----|----|----|----|----|
| Byte | | | | | | | | |
| 1 | P | 1 | F3 | F2 | F1 | F0 | 0 | 0 |
| 2 | P | 0 | X5 | X4 | X3 | X2 | X1 | X0 |
| 3 | P | 0 | X11 | X10 | X9 | X8 | X7 | X6 |
| 4 | P | 0 | Y5 | Y4 | Y3 | Y2 | Y1 | Y0 |
| 5 | P | 0 | Y11 | Y10 | Y9 | Y8 | Y7 | Y6 |

C. Remote Control via RS232

A unique feature of the Bit Pad One is that the remote host processor can completely control the operation of the Bit Pad.

Condition for Remote Control

- All internal mode and rate controls (SW 2) must be inactive or in the "OFF" condition.
- Data going to the Bit Pad One must be the same baud as the data transmitted from the Bit Pad One.
- The Bit Pad One command data must be input on J1 Pin 3 with a bit polarity of low level mark high level space.
- One of the 18 ASCII codes below must be selected, all others will be ignored.

TABLE 3-2

| Mode | Rate | | ASCII Character <u>Must Be Upper Case</u> | |
|-----------------|--------|--------|--|---|
| | ASCII | Binary | | |
| Stop | Idle | | S | |
| Point | 200 | | P | |
| Switched Stream | 2 | 2 | @ | |
| | 4 | 4 | A | |
| | 10 | 10 | B | |
| | 20 | 20 | C | |
| | 35 | 35 | D | |
| | 70 | 70 | E | |
| | 70 | 141 | F | |
| | 70 | 141 | G | |
| | Stream | 2 | 2 | H |
| | | 4 | 4 | I |
| | | 10 | 10 | J |
| | | 20 | 20 | K |
| | | 35 | 35 | L |
| 70 | | 70 | M | |
| | 70 | 141 | N | |
| | 70 | 141 | O | |

Rate is coordinate pairs per second at 19,200 baud.
All other rates are dependent on baud rates (See Table 3-4 for baud rates).

D. Cables and Connectors

1. Output Connector

RS232-C 25 pin female
AMPHENOL Type 206584-1
mates with DB-25P

2. Cable - optional

RS232 ten feet, part no. 78-6002-001
twenty feet, part no. 78-6002-002
fifty feet, part no. 78-6002-003

3. Pin Assignments

Out Connector J1

Pin Assignments--Output Connector (J1)

| <u>Pin</u> | <u>RS232 Signal</u> | <u>Code</u> |
|------------|-------------------------|-------------|
| 1 | ground | AA |
| 2 | transmit data | BA |
| 3 | receive data | BB |
| 4 | request to send | CA |
| 5 | clear to send | CB |
| 7 | ground | AB |
| 11 | transmit data TTL | SA |
| 20 | data terminal ready | CD |

E. RS232 Unit Switch Settings and Strap Options For 600 Series Proms

All units are shipped in a standard setting from the factory. If settings other than standard are desired, refer to the appropriate switch or strap below for change instructions. Standard (factory) settings are denoted by *. (See RS232 Outline Drawing, p. 38, for all switch and strap locations.)

Switch 1 (Format/Calibration)

This is a nine position switch that controls the output data format as follows:

| | |
|------------|--|
| Position 1 | } Do Not Adjust - Factory Set. Refer to Section 4, Calibration, pp. 28-29 Only if recalibration is required. |
| 2 | |
| 3 | |
| 4 | |
| 5 | |
| Position 6 | Not Used (Spare) |
| Position 7 | ON-Serial Binary Output NOTE: No CRLF transmitted when in Serial Binary (Position 8) |

*OFF-ASCII BCD Output

Position 8

* ON-Carriage Return Line Feed (CRLF). This adds line feed to the end of output data format. OFF-Carriage Return (CR) only

Position 9

* ON-English (0.005" Resolution)
OFF-Metric (0.1mm Resolution)

Switch 2 (Mode/Rate)

This is a six position switch that controls sampling mode (Point, Switch Stream or Continuous Stream) and sampling rate (X-Y coordinate pairs per second). This switch is factory set in the Continuous Stream Mode at 200 samples per second. To operate under program control (via computer), set all internal switch positions to OFF (Remote Model). If unit has optional Front Panel switches, set all internal switch positions to OFF. Mode and rate may be changed by setting the internal switch positions or depressing Front Panel buttons as shown in the Table below. (For Front Panel switches, ON corresponds to Button In and OFF corresponds to Button Out.)

TABLE 3-3
Switch 2 Mode/Rate Position Settings

| | Internal Switch 2 | Pos 1 | Pos 2 | Pos 3 | Pos 4 | Pos 5 | Pos 6 |
|---------------------------|--------------------|--------|--------|--------|--------|--------|-------|
| Mode | Front Panel Switch | Mode 2 | Mode 1 | Rate 4 | Rate 2 | Rate 1 | CLEAR |
| <u>Remote</u> | | OFF | OFF | OFF | OFF | OFF | |
| <u>Point</u> | | ON | ON | OFF | OFF | OFF | |
| <u>Switch Stream</u> | | | | | | | |
| 200 Samples/Sec | | OFF | ON | ON | ON | ON | |
| 150 | | OFF | ON | ON | ON | OFF | |
| 75 | | OFF | ON | ON | OFF | ON | |
| 40 | | OFF | ON | ON | OFF | OFF | |
| 20 | | OFF | ON | OFF | ON | ON | |
| 10 | | OFF | ON | OFF | ON | OFF | |
| 5 | | OFF | ON | OFF | OFF | ON | |
| 1 | | OFF | ON | OFF | OFF | OFF | |
| <u>*Continuous Stream</u> | | | | | | | |
| *200 | | ON | OFF | ON | ON | ON | |
| 150 | | ON | OFF | ON | ON | OFF | |
| 75 | | ON | OFF | ON | OFF | ON | |
| 40 | | ON | OFF | ON | OFF | OFF | |
| 20 | | ON | OFF | OFF | ON | ON | |
| 10 | | ON | OFF | OFF | ON | OFF | |
| 5 | | ON | OFF | OFF | OFF | ON | |
| 1 | | ON | OFF | OFF | OFF | OFF | |

Position 6 Not Used on Internal Switch.

Due to the limitations of serial baud rate transmit time, the maximum sampling rate will automatically be limited to the sampling rates shown in the table below.

TABLE 3-4

| Baud Rate | Maximum Sampling Rate | |
|-----------|-----------------------|---------------|
| | Serial ASCII BCD | Serial Binary |
| 28,800 | 85 | 166 |
| 19,200 | 68 | 141 |
| 9,600 | 46 | 105 |
| 4,800 | 28 | 65 |
| 2,400 | 16 | 37 |
| 1,200 | 9 | 20 |
| 300 | 2 | 5 |

Switch 7 and Pluggable Program Strap BA (Baud Rate)

Selection of the desired baud rate requires setting both Switch 7 and Pluggable Strap BA. One of the ten positions on Switch 7 must be set to ON and the blue Pluggable Strap must be over the center pin and the A pin or over the center pin and the B pin. Note that only one position on Switch 7 may be on at a time. Baud rate is factory set with Position 2 ON on Switch 7 and Pluggable Strap BA over pin B and the center pin. The table below lists the baud rates that may be selected.

| <u>Switch 7</u> <u>Position ON</u> | <u>Blue Pluggable Strap BA</u> | |
|---------------------------------------|--------------------------------|----------------|
| | <u>Strap A</u> | <u>Strap B</u> |
| 1 | 19,200 | 19,200 |
| *2 | 28,880 | *9,600 |
| 3 | 14,400 | 4,800 |
| 4 | 7,200 | 2,400 |
| 5 | 3,600 | 1,200 |
| 6 | 1,800 | 600 |
| 7 | 900 | 300 |
| 8 | 450 | 150 |
| 9 | 225 | 75 |
| 10 | 112.5 | -- |

Poe Strap (Parity)

Parity may be odd or even and is controlled by a wire jumper soldered into the two points on the circuit board labelled POE. The RS232 unit is shipped with no strap and is in the *even parity mode.

HCB Strap (Stop Bits)

There may be one or two stop bits transmitted. The number of bits transmitted is controlled by a wire jumper soldered into the two points on the board labelled HCB. The RS232 unit is shipped with no strap and transmits *two bits.

3. IEEE INTERFACE

A. General

The IEEE-488 1975 INTERFACE outputs the X and Y coordinates as 8 bit parallel, standard ASCII characters, one character at a time in a 12 character message string. The MODE of the Bit Pad can be controlled by the front panel or remotely programmed. The Bit Pad is remotely programmed by transferring an ASCII character over the IEEE bus. The interface conforms to the IEEE-48 1975 Digital interface for Programmable Instrumentation Standard. This permits easy interface of the Bit Pad One to any terminal, calculator or mini computer supporting the IEEE-48 standard. The standard is also known as the General Purpose Interface Bus (GPIB) or Hewlett-Packard Interface Bus (HPIB).

The IEEE (GPIB) interface output connector J1 has 16 data lines. Data is transmitted in 8-bit Bytes over an eight-line data bus. Byte transfer is controlled via a three-line transfer bus. Five other lines are used for interface management.

In operation, X-Y coordinate value are transferred from the Bit Pad One to the IEEE operating device. SW#1 Position 9 selects which basic data output mode (ON English or OFF Metric) is to be used by the Bit Pad One. The Bit Pad One controls all handshaking routines and data formatting.

Output format, transfer mode, and other parameters are selected by the IEEE options SW-3 located on the rear panel (See p. 30, IEEE Outline Dwg.). This switch and its eight sections provide system address information, format variations and transfer mode. Transfer mode may operate via a dedicated line or multiple system line. Selection of SRQ (Service Request) will provide serial poll capability for multi-system lines.

B. Data Format (Bit Pad) Switch 1 position off

X X X X D1 Y Y Y Y D1 F D2

Data Format (ID) Switch 1 position on

X X X X D1 Y Y Y Y D1 F D1 T D2

Note: XXXX are ASCII characters for the x coordinate value
 YYYY are ASCII characters for the y coordinate value
 (0000 to 2200 English, 0000 to 2794 Metric. Origin is
 in the lower left corner of tablet.)
 F is an ASCII Hexidecimal character 0-F determined by
 the flag button on the cursor or in the stylus
 D1 is delimiter selected by switch #3 position 7 & 8
 D2 is delimiter selected by switch #3 position 7 & 8
 T is a tablet identifier character which is always an
 ASCII 1

It is permissible to drop strings from the end of the transmission if the data is not needed.

i.e., INPUT @4:X,Y INSTEAD OF INPUT @4:X,Y,F
i.e., RED 708, X, INSTEAD OF RED 708, X,Y,F

C. Remote Control

The Bit Pad One mode and rate may be remotely programmed by sending the appropriate character from the host processor.

TABLE 3-5

| Mode | Rate* | ASCII Character - Upper Case Only |
|----------|-------|-----------------------------------|
| Stop | Idle | S |
| Point | 200 | P |
| Switched | 1 | @ |
| Stream | 5 | A |
| | 10 | B |
| | 20 | C |
| | 40 | D |
| | 75 | E |
| | 125 | F |
| | 125 | G |
| Stream | 1 | H |
| | 5 | I |
| | 10 | J |
| | 20 | K |
| | 40 | L |
| | 75 | M |
| | 125 | N |
| | 125 | O |

*Coordinate pairs per second. The transfer rate to the host processor is ultimately controlled by the processor and any other peripherals on the IEEE bus.

D. Output Connector

The output of the IEEE interface appears on the rear panel of the unit at J1. This connector is an IEEE industry standard 24 contact stackable female connector (Amphenol 57 series) and mates with standard IEEE-488 cable.

E. Cables

Any standard IEEE-488 interface cable may be connected to J. These cables are also stackable so that a number may be connected into one connector or end to end. A limitation of 20 meters total cable length for all devices sharing the same line must be observed.

An IEEE interface cable is not supplied with the BP-One, IEEE P/N01-0017-002 and must be ordered separately if desired. Order IEEE interface cable P/N 78-6001-001 (2 meters length) or P/N 78-6001-002 (4 meters length) from the cable price list.

F. Pin Assignments

Refer to IEEE-488 1975 interface specification.

G. IEEE Unit Switch Settings for 400 Series Proms

All units are shipped in a standard setting from the factory. If settings other than standard are desired, refer to the appropriate switch or strap below for change instructions. Standard (factory) settings are denoted by *. (See IEEE Outline Drawing, p. 39, for all switch locations.)

Switch 1 (Format/Calibration)

This is a nine position switch that controls the output data format as follows:

| | | |
|------------|---|---|
| Position 1 | } | Do Not Adjust - Factory Set. Refer to Section 4, Calibration, pp. 28-29 if recalibration is required. |
| 2 | | |
| 3 | | |
| 4 | | |
| 5 | | |
| Position 6 | } | ON = ID Format |
| 7 | | *OFF= BP Format |
| 8 | | Not used for IEEE units (Spares) |
| Position 9 | | *ON-English (0.005" Resolution) OFF-Metric (0.1mm Resolution) |

Switch 2 (Mode/Rate)

This is a six position switch that controls sampling mode (Point, Switch Stream or Continuous Stream) and sampling rate (X-Y coordinate pairs per second). This switch is factory set in the Continuous Stream Mode at 200 samples per second. (NOTE: The maximum repetition rate is dependant upon interface and software timing.) To operate under program control (via computer), set all internal switch position to OFF (Remote Mode). If unit has optional Front Panel switches, set all internal switch positions to OFF. Mode and rate may be changed by setting the internal switch positions or depressing Front Panel buttons as shown in the Table below. (For Front Panel switches, ON corresponds to Button In and Off corresponds to Button Out.)

TABLE 3-6

Switch 2 Mode/Rate Position Settings

| | Internal Switch 2 | Pos 1 | Pos 2 | Pos 3 | Pos 4 | Pos 5 | Pos 6 |
|---------------------------|-----------------------|--------|--------|--------|--------|--------|---|
| Mode | Front Panel Switch | Mode 2 | Mode 1 | Rate 4 | Rate 2 | Rate 1 | CLEAR |
| <u>Remote</u> | | OFF | OFF | OFF | OFF | OFF | Position 6 Not Used on Internal Switch. |
| <u>Point</u> | | ON | ON | OFF | OFF | OFF | |
| <u>Switch Stream</u> | | | | | | | |
| 200 Samples/Sec | | OFF | ON | ON | ON | ON | |
| 150 | | OFF | ON | ON | ON | OFF | |
| 75 | | OFF | ON | ON | OFF | ON | |
| 40 | | OFF | ON | ON | OFF | OFF | |
| 20 | | OFF | ON | OFF | ON | ON | |
| 10 | | OFF | ON | OFF | ON | OFF | |
| 5 | | OFF | ON | OFF | OFF | ON | |
| 1 | | OFF | ON | OFF | OFF | OFF | |
| <u>*Continuous Stream</u> | | | | | | | |
| *200 | | ON | OFF | ON | ON | ON | |
| 150 | | ON | OFF | ON | ON | OFF | |
| 75 | | ON | OFF | ON | OFF | ON | |
| 40 | | ON | OFF | ON | OFF | OFF | |
| 20 | | ON | OFF | OFF | ON | ON | |
| 10 | | ON | OFF | OFF | ON | OFF | |
| 5 | | ON | OFF | OFF | OFF | ON | |
| 1 | | ON | OFF | OFF | OFF | OFF | |

Switch 3 (Format Address)

This is an eight position switch. Using the first five positions, the operator can set up to thirty-one unique device address codes. String delimiters and service request can be set on the other three positions. Switch down is ON and Switch up is OFF. (Factory setting is indicated by *).

| | | |
|------------|-----|-----------------------|
| Position 1 | ON | ADDR1 (1) (LSB) |
| Position 2 | ON | ADDR2 (2) |
| 3 | ON | ADDR3 (4) |
| 4 | *ON | ADDR4 (8) |
| 5 | ON | ADDR5 (16) (MSB) |
| 6 | ON | Service Request (SRQ) |
| 7 | *ON | Form 1 |
| 8 | *ON | Form 2 |

When position 6 is ON, a service request will be generated when a coordinate pair is available. When position 6 is OFF, data will be developed and the system will halt until its talk address is received. When positions 7 and 8 are ON, string delimiters may be selected. (See table below.)

TABLE 3-7

| <u>Form 1</u> | <u>Form 2</u> | <u>Delimiter 1</u> | <u>Delimiter 2</u> | |
|---------------|---------------|--------------------|--------------------|------------------|
| *ON | *ON | CR | CR | *Tek GPIB Format |
| OFF | ON | ' | CR | Pet Format |
| ON | OFF | ' | LF | HP GPIB Format |

H. SAMPLE IEEE PROGRAMS

1. Hewlett Packard GPIB Sample Programs

A. Program #1

This program will wait for the Bit Pad to develop data, receive and display it. Tablet address is 8.

```
0:  fmt 2f8, 2f2; fxd 3
1:  red 708, X,Y,F; dsp X,Y, F
2:  gto 1
```

B. Program #2

This program will poll two tablets, when data is received it will display it, and identify the source. While waiting for an SRQ, the display will alternately show WAIT, GPIB. Tablet addresses are 4 and 8.

```
0:  fmt 2f8, 2f2; fxd 3
1:  oni 7, "TABLET"
2:  eir 7
3:  dsp "WAIT"; wait 1000
4:  dsp "GPIB"; wait 1000
5:  gto 2
6:  "TABLET": rds (708) --- A
7:  if A- 0; gto 11
8:  red 708, X,Y,F; dsp X,Y,F
9:  wait 1000; dsp "TABLET 8"
10: wait 1000
11: rds (704) --- A
12: if A-0; iret
13: red 704, X,Y,F; dsp X,Y,F
14: wait 1000; dsp "TABLET 4"
15: wait 1000; iret
```

NOTE: An untalk command should be issued after data transfer is complete in serial Poll Mode.

The following program will input tablet data to the HP 9815 stack only:

| | | <u>REMARKS</u> |
|----------|-----------|--------------------------|
| 0 0 0 0 | FIX 3 | Number of decimal places |
| 0 0 0 2 | 0 | |
| 0 0 0 3 | 8 | |
| 0 0 0 4 | ENTER | Address 8 onto stack |
| 0 0 0 5 | READX 5 | Input data @ Address 8 |
| 0 0 0 7 | PRT STK | Print Stack |
| 0 0 0 8 | GOTO 0002 | Repeat |
| 0 0 0 10 | End | |

Program step 0000 will vary with output format of the I.D.

2. Tektronix 4051 Sample Programs

A. Program #1

This program inputs coordinate BCD data and prints it out without the use of the service request.

| | |
|-----|--------------------|
| 100 | INIT |
| 110 | PRINT @ 32, 26:2 |
| 120 | INPUT @ 8: X,Y,F\$ |
| 130 | PRINT X,Y,F\$ |
| 140 | GO TO 120 |
| 150 | STOP |

B. Program #2

This program inputs coordinate BCD data and prints it out using the serial poll capability of the TEK 4051. The SRQ switch must be on for interface to operate in this mode.

| | |
|-----|-------------------------------------|
| 100 | INIT |
| 110 | PRINT @ 32, 26:2 |
| 120 | ON SRQ THEN 160 |
| 130 | PRINT "WAITING FOR SERVICE REQUEST" |
| 140 | WAIT |
| 150 | GO TO 130 |
| 160 | POLL M, N;8 |
| 170 | GO TO M OF 180 |
| 180 | INPUT @ 8: X,Y,F\$ |
| 190 | PRINT X,Y,F\$ |
| 200 | RETURN |
| 210 | STOP |

C. Program #3

This program outputs an ASCII character which will remotely program the MODE of the Bit Pad. Address 8 is assumed and point mode is selected.

| | |
|-----|------------------|
| 100 | INIT |
| 110 | PRINT @ 32, 26:2 |
| 120 | PRINT @ 8: "P" |
| 130 | STOP |

4. PARALLEL INTERFACE

A. General

Within this interface, two modes, Binary and Binary Coded Decimal (BCD) are switch selectable. In the Binary mode, five eight bit bytes are output for each coordinate pair. In the BCD mode, twelve ASCII BCD characters are output for each coordinate pair. The data transfer rate may be a maximum of 200 coordinate pairs per second, depending on the receiving device. The BCD interface is specially designed to permit the Bit Pad One to be plugged into the Remote Keyboard port on a CRT or microcomputer.

B. Parallel Binary

Parallel Binary is selected by turning Switch 1 Position 7 to the ON position. This enables the 5 byte parallel binary transfer of data.

There are three control lines that can be used to control the transmission speed of the five bytes of coordinate data. The three control signals are defined as Byte Available, Byte Received and Next Byte. Byte Available signifies that a byte of data is available; Byte Received signifies that the byte of data has been read by the host processor; and Next Byte is used by the host processor to request the next byte of data to be transmitted.

C. Parallel Binary Format -- for each coordinate pair five bytes of data are transmitted as follows:

TABLE 3-8

| CONNECTOR J1-Pin Pin Function | 22 Out 7 | 20 Out 6 | 18 Out 5 | 16 Out 4 | 14 Out 3 | 12 Out 2 | 10 Out 1 | 8 Out 0 | 25 Data Stro |
|----------------------------------|-------------|-------------|-------------|-------------|-------------|-------------|-------------|------------|-----------------|
| Byte 1 | 1 | Byte Avail. | F3 | F2 | F1 | F0 | 0 | 0 | |
| Byte 2 | 0 | " | X5 | X4 | X3 | X2 | X1 | X0 | |
| Byte 3 | 0 | " | X11 | X10 | X9 | X8 | X7 | X6 | |
| Byte 4 | 0 | " | Y5 | Y4 | Y3 | Y2 | Y1 | Y0 | |
| Byte 5 | 0 | " | Y11 | Y10 | Y9 | Y8 | Y7 | Y6 | |
| | MSB | | | | | | | | LSB |

F0 - Z Axis Switch
 F1, F2, F3 - Flag Byte
 X0 - X11 - 12 bit X coordinate
 Y0 - Y11 - 12 bit Y coordinate

*Data Strobe is a negative or positive pulse strappable using points C and D, which emulates Byte available.

D. Parallel BCD

Parallel ASCII is selected by turning Switch 1 Position 7 to the OFF position. This enables the 12 byte parallel ASCII transfer. There are three control lines that can be used to control the transmission speed of the 12 bytes of coordinate data. The three control signals are defined as Byte Available, Byte Received, and Next Byte. Byte Available signifies that a byte of data is available; Byte Received signifies that the byte of data has been read by the host processor; and Next Byte is used by the host processor to request the next byte for data to be transmitted.

TABLE 3-9 Paralled BCD Format

| CONNECTOR J1-Pin Pin Function | 22 BYTE Avail. | 20 | 18 | 16 | 14 | 12 | 10 | 8 | 25 Data* Strobe | |
|----------------------------------|----------------------|-----------------|----|----|--------------|----|----------|-----|-----------------------|--|
| BYTE 1 | | 0 | 1 | 1 | X Coordinate | | X3 - BCD | | | |
| BYTE 2 | | 0 | 1 | 1 | | | X2 - BCD | | | |
| BYTE 3 | | 0 | 1 | 1 | | | X1 - BCD | | | |
| BYTE 4 | | 0 | 1 | 1 | | | X0 - BCD | | | |
| BYTE 5 | | 0 | 1 | 0 | 1 | 1 | 0 | 0 | | |
| BYTE 6 | | 0 | 1 | 1 | Y Coordinate | | Y3 - BCD | | | |
| BYTE 7 | | 0 | 1 | 1 | | | Y2 - BCD | | | |
| BYTE 8 | | 0 | 1 | 1 | | | Y1 - BCD | | | |
| BYTE 9 | | 0 | 1 | 1 | | | Y0 - BCD | | | |
| BYTE 10 | | 0 | 1 | 0 | 1 | 1 | 0 | 0 | | |
| BYTE 11 | | F L A G D A T A | | | | | | | | |
| BYTE 12 | | 0 | 0 | 0 | 1 | 1 | 0 | 1 | | |
| BYTE 13* | | 0 | 0 | 0 | 1 | 0 | 1 | 0 | | |
| | | MSB | | | | | | LSB | | |

*Optional Line Feed SW-1, Position 8

BYTES 1 through 4 BCD Digits of X Coordinate XXXX

BYTES 6 through 9 BCD Digits of Y Coordinate YYYY

BYTES 5 and 10 ASCII Comma ,

BYTE 11 Hexadecimal Representation of Cursor Flag

BYTE 12 ASCII Carriage Return

BYTE 13 Optional ASCII Line Feed

XXXX and YYYY are ASCII numbers that range in magnitude from 0000 to 2200 in the English mode or 0000 to 2794 in the Metric mode. Origin (0000) is in the lower left corner of the tablet.

The following Flow diagram (see next page) describes the handshaking and use of interface signals by the Bit Pad One and host processor. Coupled with the timing diagrams, this will provide the necessary information to interface the Bit Pad One to a parallel processor port.

It should be noted that the host processor can be operated in the interrupt mode if desired. To do this, the Data Strobe or Data Strobe line would be connected to the interrupt line on the host processor. The Data Strobe or Data Strobe line is a 1.5 us pulse exercised for every byte of coordinate data.

Additionally, if the host processor is fast enough to receive data at the maximum rate of the Bit Pad, transmission need not be controlled by the host processor. If no connection or control is exercised on the byte received and next byte control lines; the five bytes will be transmitted without handshaking. In summary, there are four basic interfacing modes for the Bit Pad. They are:

1. Polled - Controlled transmission rate
2. Polled - Uncontrolled (full speed) (consult Signal Timing Diagram--Section 5)
3. Interrupt Driven - Controlled transmission rate
4. Interrupt Driven - Uncontrolled (full speed)

E. Parallel Remote Control

A unique feature of the Bit Pad One is that all mode and rate controls are duplicated on the interface connector so that the host processor can completely control the operation of the Bit Pad. The format of the Command Byte is as follows:

| Next Byte | Byte Recv | Mode 2 | Mode 1 | Rate 4 | Rate 2 | Rate 1 | Status Valid |
|------------|------------|------------|------------|------------|------------|-----------|--------------|
| IN 7 21 | IN 6 19 | IN 5 17 | IN 4 15 | IN 3 13 | IN 2 11 | IN 1 9 | IN 0 7 |

These eight bits are labeled on the connector diagram as IN0 - IN 7, where IN0 is the Status Valid Bit; IN1 is rate 1, etc. The Command Byte, Rate Bits and the Command Byte Mode bits are identical in function to the manual controls. A logical "1" in the Command Byte is equivalent to a switch "out" (off), and a logical "0" in the Command Byte is equivalent to a switch "in" (on). The one exception to this is when both mode bits and status valid are logical "1's" (with one of the manual rate switches active), in which case the Bit Pad One operates in the diagnostic mode which is defined in a later section. These five bits are not latched, that is they must be connected to a latched output port on the host processor. The Status Valid bit informs the Bit Pad that a change is desired to the mode and rate bits. If a Status Valid equals a "1", the Bit Pad will read the Command Byte. If Status Valid equals a "0", the Bit Pad will search either for a front panel switch closure or a remote command with an active status valid. Therefore, whenever the host processor is changing the rate or mode setting of the Command Byte, it should first set Status Valid equal to a "0", then change the desired mode and/or rate setting, and finally return Status Valid to a "1".

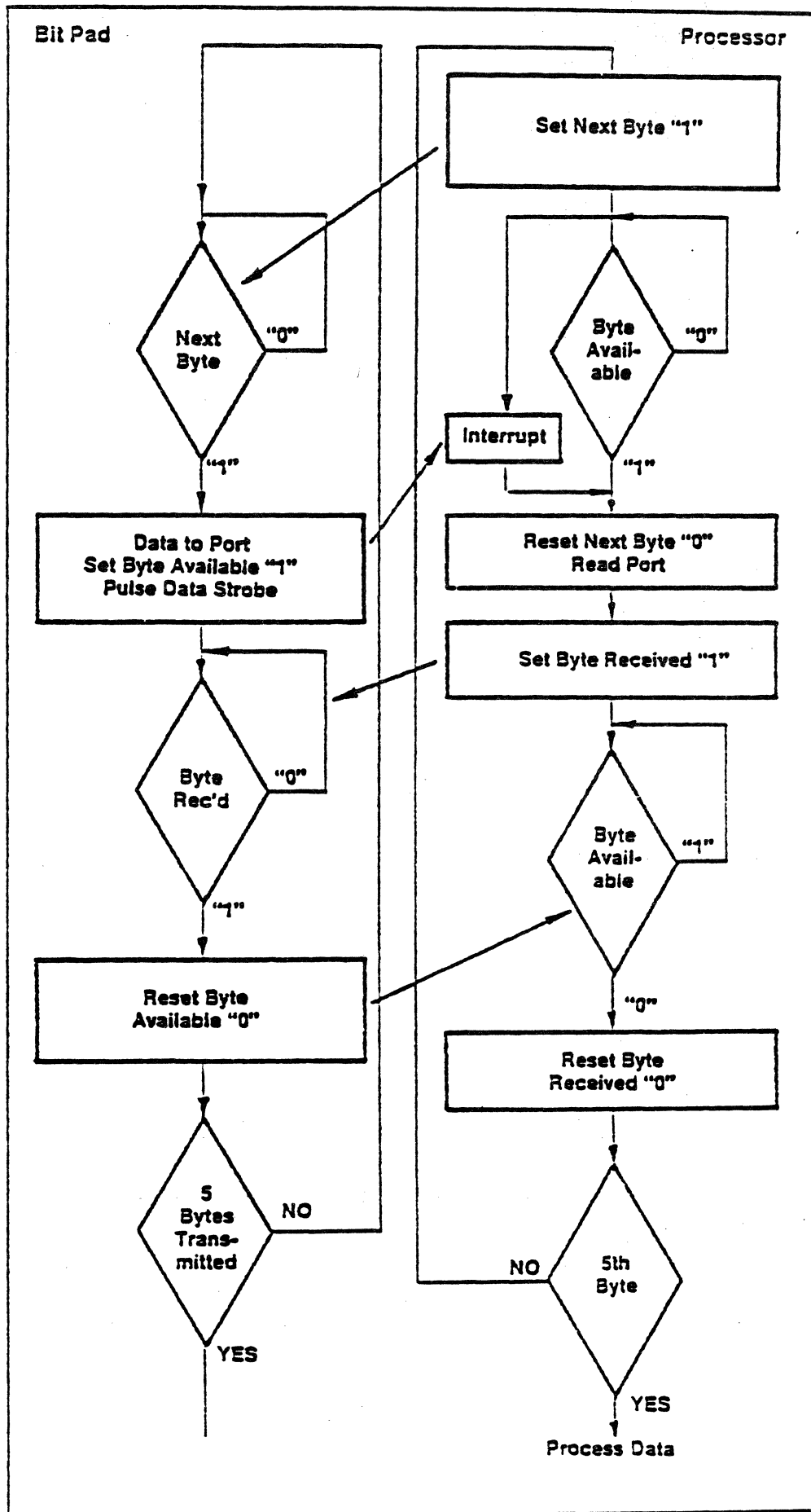

The two other bits on the Command Byte, Next Byte and Byte Received, are part of the three wire handshake used to control transmission speed of the Bit Pad and were covered in the previous section.

There is one additional signal line that is an input to the Bit Pad. This line is designated remote reset on the connector diagram. This line allows the host processor to reset the Bit Pad should it become necessary.

TABLE 3-10

| CONNECTOR J1-Pin Pin Function | | 21 IN 7 | 19 IN 6 | 17 IN 5 | 15 IN 4 | 13 IN 3 | 11 IN 2 | 9 IN 1 | 7 IN 0 | |
|----------------------------------|------|--------------|---------------|------------|------------|------------|------------|-----------|--------------|-----|
| MODE | RATE | NEXT BYTE | BYTE REC'V | MODE 2 | MODE 1 | RATE 4 | RATE 3 | RATE 2 | STAT VALI | |
| Stop Point Stream | Idle | | | 1 | 1 | 1 | 1 | 1 | | |
| | 200 | | | 0 | 0 | - | - | - | | |
| | 1 | | | 0 | 1 | 1 | 1 | 1 | | |
| | 5 | | | | | 1 | 1 | 0 | | |
| | 10 | | | | | 1 | 0 | 1 | | |
| | 20 | | | | | 1 | 0 | 0 | | |
| | 40 | | | | | 0 | 1 | 1 | | |
| | 75 | | | | | 0 | 1 | 0 | | |
| | 150 | | | | | 0 | 0 | 1 | | |
| | 200 | | | | | 0 | 0 | 0 | | |
| Switched Stream | 1 | | | 1 | 0 | 1 | 1 | 1 | | |
| | 5 | | | | | 1 | 1 | 0 | | |
| | 10 | | | | | 1 | 0 | 1 | | |
| | 20 | | | | | 1 | 0 | 0 | | |
| | 40 | | | | | 0 | 1 | 1 | | |
| | 75 | | | | | 0 | 1 | 0 | | |
| | 150 | | | | | 0 | 0 | 1 | | |
| | 200 | | | | | 0 | 0 | 0 | | |
| | | | MSB | | | | | | | LSB |

*Rate is coordinate pairs per second

F. Output Connector

Parallel

25 pin female
AMPHENOL type 206584-1
mates with DB-25p

Cable

optional RS232 cable
ten feet, part no. 78-6002-001
twenty feet, part no. 78-6002-002
fifty feet, part no. 78-6002-003

| Pin Assignments | | Output connector J1 | |
|-----------------|---------------------------------|---------------------|---------------|
| <u>Pin</u> | <u>Signal</u> | <u>Pin</u> | <u>Signal</u> |
| 1 | Ground | 13 | in 3 |
| 2 | Remote Reset | 14 | out 3 |
| 3 | Not used | 15 | in 4 |
| 4 | Strappable +5 Volts (output) | 16 | out 4 |
| 5 | Not used | 17 | in 5 |
| 6 | Not used | 18 | out 5 |
| 7 | in 0 | 19 | in 6 |
| 8 | out 0 | 20 | out 6 |
| 9 | in 1 | 21 | in 7 |
| 10 | out 1 | 22 | out 7 |
| 11 | in 2 | 23 | Ground |
| 12 | out 2 | 24 | Not used |
| | | 25 | Data Strobe |

In 0 through In 7 is the binary remote control byte (see page 25, Table 3-10).
Out 0 through Out 7 is the binary output data byte (see page 21, Table 3-8).

Parallel Unit Switch Settings and Strap Options for 500 Series Proms

All units are shipped in a standard setting from the factory. If settings other than standard are desired, refer to the appropriate switch or strap below for change instructions. Standard (factory) settings are denoted by *. (See Parallel Outline Drawing, p. 40, for all strap and switch locations.)

Switch 1 Format/Calibration)

This is a nine position switch that controls the output data format as follows:

| | | |
|------------|---|---|
| Position 1 | } | Do Not Adjust - Factory Set. Refer to Section 4, Calibration, pp. 28-29 if recalibration is required. |
| 2 | | |
| 3 | | |
| 4 | | |
| 5 | | |
| Position 6 | | Not Used (Spare) |
| Position 7 | | *ON-Parallel Binary Output (NOTE: No CRLF transmitted when in Parallel Binary - Position 8) OFF-ASCII BCD Output |
| Position 8 | | *ON-Carriage Return Line Feed (CRLF). This adds line feed to the end of output data format. OFF-Carriage Return (CR) only. |
| Position 9 | | *ON-English (0.005" Resolution) OFF-Metric (0.1mm Resolution) |

Switch 2 (Mode/Rate)

This is a six position switch that controls sampling mode (Point, Switch Stream or Continuous Stream) and sampling rate (X-Y coordinate pairs per second). This switch is factory set in the Continuous Stream Mode at 200 samples per second.* To operate under program control (via computer), set all internal switch positions to OFF (Remote Mode). If unit has optional Front Panel switches, set all internal switch positions to OFF. Mode and rate may be changed by setting the internal switch positions or depressing Front Panel buttons as shown in the Table below. (For Front Panel switches, ON corresponds to Button In and OFF corresponds to Button Out.)

TABLE 3-11
Switch 2 Mode/Rate Position Settings

| | Internal Switch 2 | Pos 1 | Pos 2 | Pos 3 | Pos 4 | Pos 5 | Pos 6 |
|---------------------------|--------------------|--------|--------|--------|--------|--------|---|
| Mode | Front Panel Switch | Mode 2 | Mode 1 | Rate 4 | Rate 2 | Rate 1 | CLEAR |
| <u>Remote</u> | | OFF | OFF | OFF | OFF | OFF | Position 6 Not Used on Internal Switch. |
| <u>Point</u> | | ON | ON | OFF | OFF | OFF | |
| <u>Switch Stream</u> | | | | | | | |
| 200 Samples/Sec | | OFF | ON | ON | ON | ON | |
| 150 | | OFF | ON | ON | ON | OFF | |
| 75 | | OFF | ON | ON | OFF | ON | |
| 40 | | OFF | ON | ON | OFF | OFF | |
| 20 | | OFF | ON | OFF | ON | ON | |
| 10 | | OFF | ON | OFF | ON | OFF | |
| 5 | | OFF | ON | OFF | OFF | ON | |
| 1 | | OFF | ON | OFF | OFF | OFF | |
| <u>*Continuous Stream</u> | | | | | | | |
| *200 | | ON | OFF | ON | ON | ON | |
| 150 | | ON | OFF | ON | ON | OFF | |
| 75 | | ON | OFF | ON | OFF | ON | |
| 40 | | ON | OFF | ON | OFF | OFF | |
| 20 | | ON | OFF | OFF | ON | ON | |
| 10 | | ON | OFF | OFF | ON | OFF | |
| 5 | | ON | OFF | OFF | OFF | ON | |
| 1 | | ON | OFF | OFF | OFF | OFF | |

CD Strap (Polarity of Data Strobe)

The data strobe may be either a positive or negative pulse. If the Pluggable Strap is placed over the center pin and the C pin, the pulse will be positive. If the Pluggable Strap is placed over the center the center pin and the D pin, the pulse will be negative. The Parallel unit is shipped with Strap in *D position (Negative).

SECTION 4

1. MAINTENANCE

A. Internal Diagnostics

The Bit Pad control unit contains two test functions that can be used to 1) Verify proper operation of most of the Bit Pad electronics and 2) Verify proper connections to the host processor.

Internal Test Mode (D1) - To place the unit in D1 (internal test mode) set switch 2 positions as follows:

| 1 | 2 | 3 | 4 | 5 | 6 |
|-----|-----|----|-----|-----|----------|
| off | off | on | off | off | not used |

Set the command byte mode bits to logicals one (1). If there is nothing connected to the command byte lines they will normally be at a logical "1". However, if these lines are connected to a port on the host processor, then the processor must output logic "1's" on these lines. The control unit will now attempt to check out all internal circuitry. If everything checks out, it will pulse the First Byte line at a two-second duty cycle (slow enough to be detected by a meter). If all does not check out, the First Byte line will remain a logic high or a logic low.

Interface Test Mode - To place the unit in D2 (interface test mode), set switch 2 positions as follows:

| 1 | 2 | 3 | 4 | 5 | 6 |
|-----|-----|-----|----|-----|----------|
| off | off | off | on | off | not used |

The Bit Pad One will output a constant pattern which can be used to verify interface operations. All control lines will be operable as if the Bit Pad One were transmitting normally. The data sent will be the five bytes below:

```

Byte 1  1  1  0  0  0  0  0  0
Byte 2  0  1  1  0  1  0  1  0
Byte 3  0  1  0  1  0  1  0  1
Byte 4  0  1  1  0  1  0  1  0
Byte 5  0  1  0  1  0  1  0  1
    
```

2. CALIBRATION

Note: Preset at Factory - It is not necessary to calibrate unless tablets are exchanged with the controllers or a desired change in Metric or English resolution. Necessary equipment for calibration:

1. Tablet Calibration Look-up Table.
2. Accurate measuring device. (Precision Ruler, Precision Grid, etc.)

SELECTION OF RESOLUTION

- SW1 Position 9 ON = English (0.005" Resolution)
- SW1 Position 9 OFF = Metric Resolution .1mm

CALIBRATION PROCEDURE

1. Bias the Tablet.
2. Note the wire speed number located on the tablet corner bracket. (Should fall between 3986 and 4040).
3. By using the tablet calibration look up tablet, find appropriate line in which your wire speed number falls within.
 Example: Wire Speed Number - 4007.
 Line 9 of the tablet calibration look up table is the line in which your wire speed number falls within 4006 to 4009.
4. Once you have determined the line at which your wire speed number falls within, you can set the Bit Pad One Calibration Switch (Switch 1) with the switch codes that is listed on that line. NOTE: The switch codes given in the table below are approximate and may vary within +5 counts of accuracy at the completion of the absolute accuracy check.

CALIBRATION

The code on the line is used to represent Switch 1 Positions 1-5. A "1" in the code is equivalent to Switch Position ON, a "0" code is equivalent to a Switch Position OFF.

WIRE SPEED

| <u>FROM</u> | Switch 1 <u>54321</u> | <u>TO</u> |
|-------------|--------------------------|-----------|
| 3986 | 11101 | 3989 |
| 3990 | 11100 | 3993 |
| 3994 | 11011 | 3994 |
| 3995 | 11011 | 3997 |
| 3998 | 11010 | 3999 |
| 4000 | 11010 | 4001 |
| 4002 | 11001 | 4004 |
| 4005 | 11001 | 4005 |
| 4006 | 11000 | 4009 |
| 4010 | 10111 | 4013 |
| 4014 | 10110 | 4014 |
| 4015 | 10110 | 4017 |
| 4018 | 10101 | 4019 |
| 4020 | 10101 | 4021 |
| 4022 | 10100 | 4024 |
| 4025 | 10100 | 4025 |
| 4026 | 10011 | 4029 |

| <u>FROM</u> | Switch 1 <u>54321</u> | <u>TO</u> |
|-------------|--------------------------|-----------|
| 4030 | 10010 | 4033 |
| 4034 | 10001 | 4034 |
| 4035 | 10001 | 4037 |
| 4038 | 10000 | 4039 |
| 4040 | 10000 | 4041 |
| 4042 | 01111 | 4044 |
| 4045 | 01111 | 4045 |
| 4046 | 01110 | 4049 |
| 4050 | 01101 | 4053 |
| 4054 | 01101 | 4054 |
| 4055 | 01100 | 4057 |
| 4058 | 01011 | 4059 |
| 4060 | 01011 | 4061 |
| 4062 | 01010 | 4065 |
| 4066 | 01001 | 4069 |
| 4070 | 01000 | 4070 |
| 4071 | 01000 | 4073 |
| 4074 | 00111 | 4075 |
| 4076 | 00111 | 4077 |
| 4078 | 00110 | 4080 |
| 4081 | 00110 | 4081 |
| 4082 | 00101 | 4085 |
| 4086 | 00100 | 4089 |
| 4090 | 00011 | 4090 |

ABSOLUTE ACCURACY CHECK

The Absolute Accuracy of the tablet and controller can easily be checked with the use of accurate ruler. Select two (2) points on the X axis, a known distance apart. Digitize the left point first and note the X coordinate as X1; then digitize the right point, note its X coordinate as X2. The results by subtracting X1 from X2 should be within 2 counts of the original known distance. Switch 1 Positions 1 through 5 may be changed to bring the system into calibration. Position 1 represents the smallest change.

3. STYLUS REFILL REPLACEMENT

Your Summagraphics stylus has been designed to allow the user to replace the ball point refill (when it becomes dry or to change color). To change or replace refill simply:

1. Unscrew front section of stylus.
2. Grasp internal front section and carefully pull it straight off.
Note: internal front section may come off with outer cover. If this occurs, remove inner section before attempting to reassemble stylus or you may damage the miniature connector.
3. Pull out refill and replace with a new one.
4. Replace front inner section and mate connectors.
5. Replace outer cover.

SECTION 5

BIT PAD ONE DRAWINGS

| REV | BY | DATE | APP | DATE |
|-----|----|----------|-----|------|
| 1 | WJ | 11/27/71 | | |
| 2 | WJ | 12/27/71 | | |
| 3 | WJ | 1/27/72 | | |
| 4 | WJ | 2/27/72 | | |
| 5 | WJ | 3/27/72 | | |
| 6 | WJ | 4/27/72 | | |
| 7 | WJ | 5/27/72 | | |
| 8 | WJ | 6/27/72 | | |
| 9 | WJ | 7/27/72 | | |
| 10 | WJ | 8/27/72 | | |
| 11 | WJ | 9/27/72 | | |
| 12 | WJ | 10/27/72 | | |

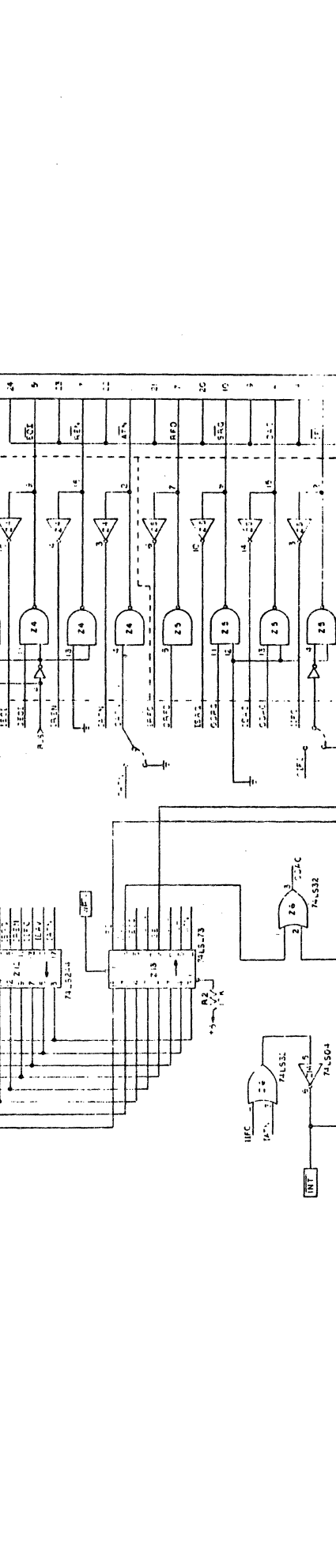
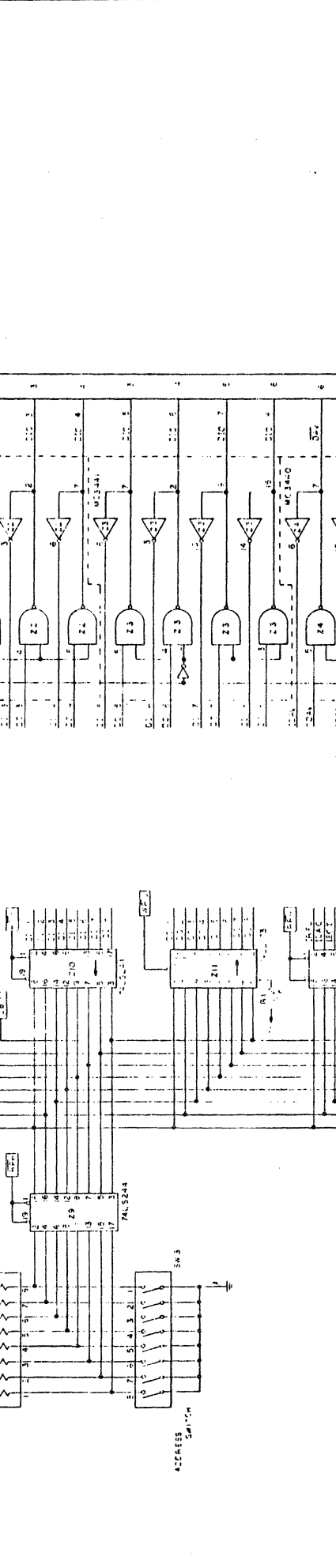
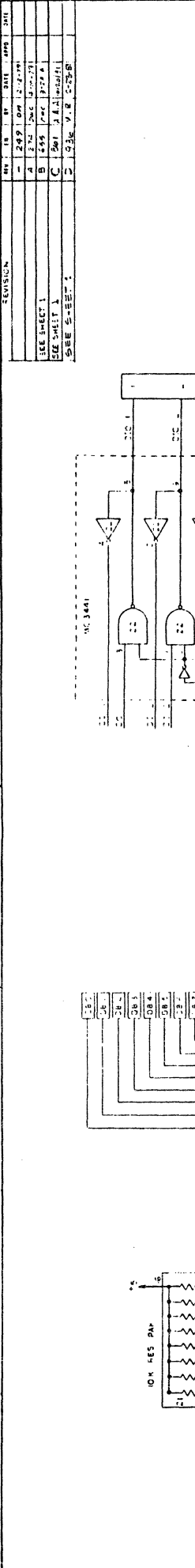

| REV | DATE | DESCRIPTION | REV |
|-----|----------|-------------|-----|
| 1 | 11/27/71 | | |
| 2 | 12/27/71 | | |
| 3 | 1/27/72 | | |
| 4 | 2/27/72 | | |
| 5 | 3/27/72 | | |
| 6 | 4/27/72 | | |
| 7 | 5/27/72 | | |
| 8 | 6/27/72 | | |
| 9 | 7/27/72 | | |
| 10 | 8/27/72 | | |
| 11 | 9/27/72 | | |
| 12 | 10/27/72 | | |

| | | |
|--|--------------|----------------|
| DATE: 11/27/71 | DESIGNER: WJ | SCALE: |
| DRAWN BY: WJ | CHECKED: WJ | DATE: 11/27/71 |
| TITLE: LOGIC DIA. PWR. BOARD, BIT PULSE CONTROLLER (SEE CAPEN) | PROJECT NO.: | |
| DATE: 11/27/71 | DESIGNER: WJ | SCALE: |
| DRAWN BY: WJ | CHECKED: WJ | DATE: 11/27/71 |

| | | |
|--|--------------|----------------|
| DATE: 11/27/71 | DESIGNER: WJ | SCALE: |
| DRAWN BY: WJ | CHECKED: WJ | DATE: 11/27/71 |
| TITLE: LOGIC DIA. PWR. BOARD, BIT PULSE CONTROLLER (SEE CAPEN) | PROJECT NO.: | |
| DATE: 11/27/71 | DESIGNER: WJ | SCALE: |
| DRAWN BY: WJ | CHECKED: WJ | DATE: 11/27/71 |

| | | |
|--|--------------|----------------|
| DATE: 11/27/71 | DESIGNER: WJ | SCALE: |
| DRAWN BY: WJ | CHECKED: WJ | DATE: 11/27/71 |
| TITLE: LOGIC DIA. PWR. BOARD, BIT PULSE CONTROLLER (SEE CAPEN) | PROJECT NO.: | |
| DATE: 11/27/71 | DESIGNER: WJ | SCALE: |
| DRAWN BY: WJ | CHECKED: WJ | DATE: 11/27/71 |

| | | |
|--|--------------|----------------|
| DATE: 11/27/71 | DESIGNER: WJ | SCALE: |
| DRAWN BY: WJ | CHECKED: WJ | DATE: 11/27/71 |
| TITLE: LOGIC DIA. PWR. BOARD, BIT PULSE CONTROLLER (SEE CAPEN) | PROJECT NO.: | |
| DATE: 11/27/71 | DESIGNER: WJ | SCALE: |
| DRAWN BY: WJ | CHECKED: WJ | DATE: 11/27/71 |

| | | |
|--|--------------|----------------|
| DATE: 11/27/71 | DESIGNER: WJ | SCALE: |
| DRAWN BY: WJ | CHECKED: WJ | DATE: 11/27/71 |
| TITLE: LOGIC DIA. PWR. BOARD, BIT PULSE CONTROLLER (SEE CAPEN) | PROJECT NO.: | |
| DATE: 11/27/71 | DESIGNER: WJ | SCALE: |
| DRAWN BY: WJ | CHECKED: WJ | DATE: 11/27/71 |

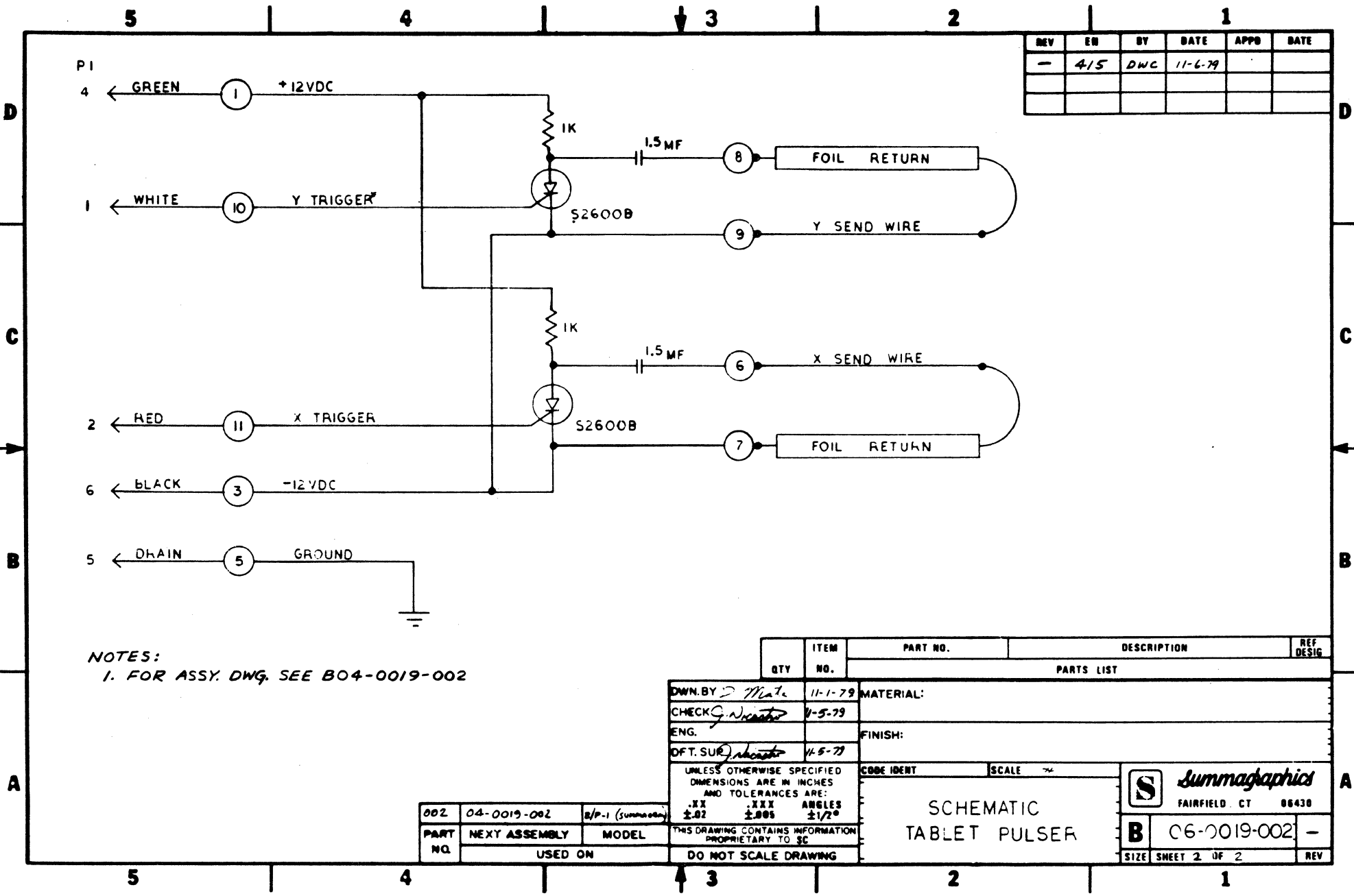

| REV | EN | BY | DATE | APPD | DATE |
|-----|-----|-----|---------|------|------|
| - | 415 | DWC | 11-6-79 | | |
| | | | | | |
| | | | | | |

NOTES:
1. FOR ASSY. DWG. SEE B04-0019-002

| 002 | 04-0019-002 | S/P-1 (summary) |
|----------|---------------|-----------------|
| PART NO. | NEXT ASSEMBLY | MODEL |
| | | |

| QTY | ITEM NO. | PART NO. | DESCRIPTION | REF DESIG |
|--|----------|-------------|-------------|-----------|
| PARTS LIST | | | | |
| DWN. BY <i>D. Mate</i> | | 11-1-79 | MATERIAL: | |
| CHECK <i>G. Winters</i> | | 4-5-79 | FINISH: | |
| ENG. <i>G. Winters</i> | | 4-5-79 | SCALE: | |
| DFT. SUR. <i>G. Winters</i> | | 4-5-79 | CODE IDENT: | |
| UNLESS OTHERWISE SPECIFIED DIMENSIONS ARE IN INCHES AND TOLERANCES ARE: .XX .XXX ANGLES ±.02 ±.005 ±1/2° | | | | |
| SCHEMATIC TABLET PULSER | | | | |
| THIS DRAWING CONTAINS INFORMATION PROPRIETARY TO SC | | | | |
| DO NOT SCALE DRAWING | | | | |
| Summagraphics FAIRFIELD, CT 06430 | | S | | |
| B | | 06-0019-002 | | - |
| SIZE SHEET 2 OF 2 | | | | REV |

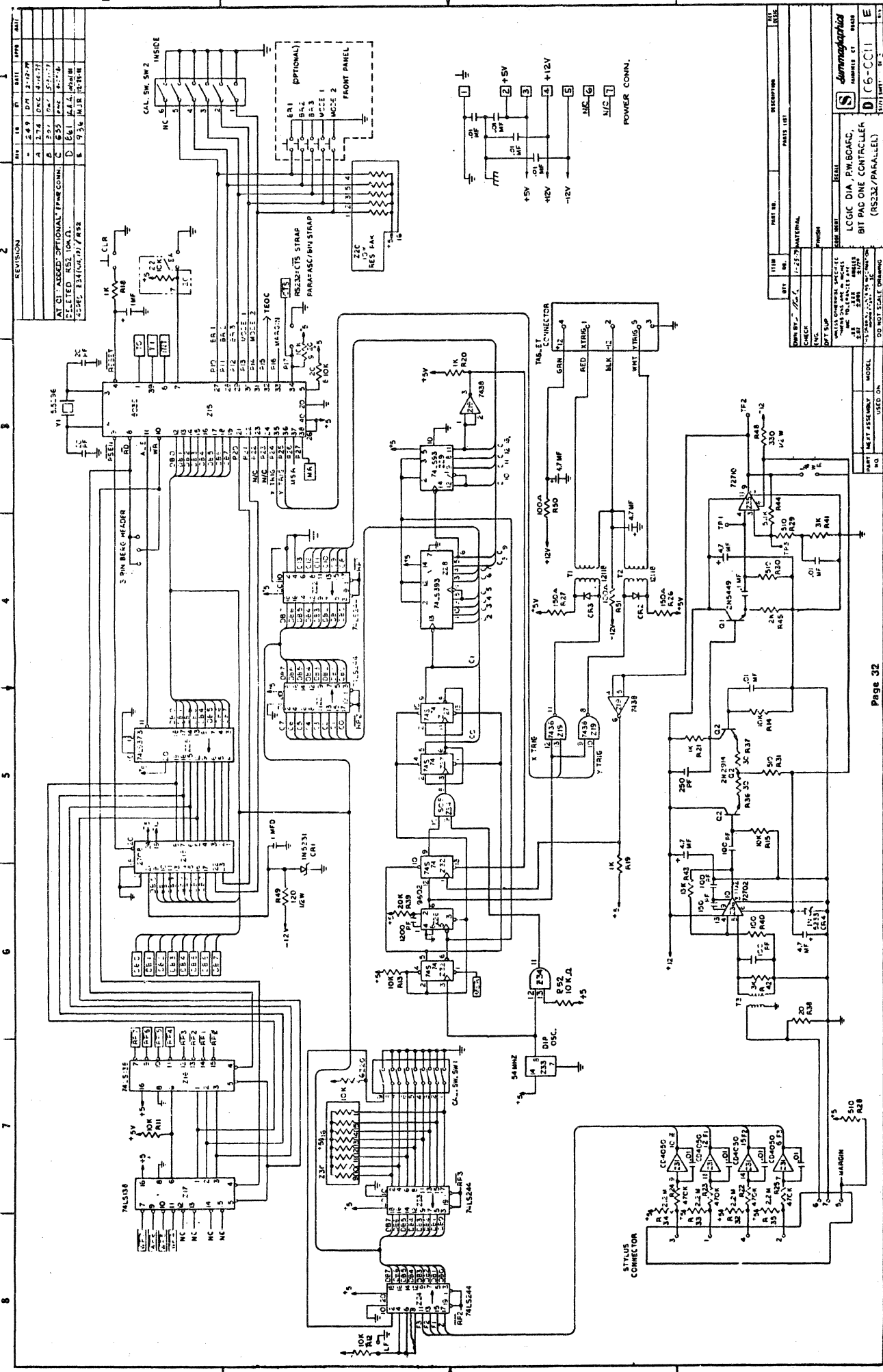

| REV | DATE | BY | CHK | APP | REASON |
|-----|----------|----|-----|-----|------------------------------------|
| 1 | 12/17/74 | JM | DM | JM | INITIAL DESIGN |
| 2 | 1/10/75 | JM | DM | JM | REVISED TO ADD 100 OHM TERMINATION |
| 3 | 1/15/75 | JM | DM | JM | REVISED TO ADD 100 OHM TERMINATION |
| 4 | 1/22/75 | JM | DM | JM | REVISED TO ADD 100 OHM TERMINATION |
| 5 | 1/29/75 | JM | DM | JM | REVISED TO ADD 100 OHM TERMINATION |
| 6 | 2/5/75 | JM | DM | JM | REVISED TO ADD 100 OHM TERMINATION |
| 7 | 2/12/75 | JM | DM | JM | REVISED TO ADD 100 OHM TERMINATION |
| 8 | 2/19/75 | JM | DM | JM | REVISED TO ADD 100 OHM TERMINATION |
| 9 | 2/26/75 | JM | DM | JM | REVISED TO ADD 100 OHM TERMINATION |
| 10 | 3/5/75 | JM | DM | JM | REVISED TO ADD 100 OHM TERMINATION |

| REV | DATE | BY | CHK | APP | REASON |
|-----|----------|----|-----|-----|------------------------------------|
| 1 | 12/17/74 | JM | DM | JM | INITIAL DESIGN |
| 2 | 1/10/75 | JM | DM | JM | REVISED TO ADD 100 OHM TERMINATION |
| 3 | 1/15/75 | JM | DM | JM | REVISED TO ADD 100 OHM TERMINATION |
| 4 | 1/22/75 | JM | DM | JM | REVISED TO ADD 100 OHM TERMINATION |
| 5 | 1/29/75 | JM | DM | JM | REVISED TO ADD 100 OHM TERMINATION |
| 6 | 2/5/75 | JM | DM | JM | REVISED TO ADD 100 OHM TERMINATION |
| 7 | 2/12/75 | JM | DM | JM | REVISED TO ADD 100 OHM TERMINATION |
| 8 | 2/19/75 | JM | DM | JM | REVISED TO ADD 100 OHM TERMINATION |
| 9 | 2/26/75 | JM | DM | JM | REVISED TO ADD 100 OHM TERMINATION |
| 10 | 3/5/75 | JM | DM | JM | REVISED TO ADD 100 OHM TERMINATION |

| REV | DATE | BY | CHK | APP | REASON |
|-----|----------|----|-----|-----|------------------------------------|
| 1 | 12/17/74 | JM | DM | JM | INITIAL DESIGN |
| 2 | 1/10/75 | JM | DM | JM | REVISED TO ADD 100 OHM TERMINATION |
| 3 | 1/15/75 | JM | DM | JM | REVISED TO ADD 100 OHM TERMINATION |
| 4 | 1/22/75 | JM | DM | JM | REVISED TO ADD 100 OHM TERMINATION |
| 5 | 1/29/75 | JM | DM | JM | REVISED TO ADD 100 OHM TERMINATION |
| 6 | 2/5/75 | JM | DM | JM | REVISED TO ADD 100 OHM TERMINATION |
| 7 | 2/12/75 | JM | DM | JM | REVISED TO ADD 100 OHM TERMINATION |
| 8 | 2/19/75 | JM | DM | JM | REVISED TO ADD 100 OHM TERMINATION |
| 9 | 2/26/75 | JM | DM | JM | REVISED TO ADD 100 OHM TERMINATION |
| 10 | 3/5/75 | JM | DM | JM | REVISED TO ADD 100 OHM TERMINATION |

LCGIC D1A P.M. BOARD,
BIT PAD ONE CONTROLLER
(RS32/PARALLEL)

| REV | LN | BY | DATE | APPD | DATE |
|-----|-----|------|----------|------|------|
| - | 249 | DM | 2-12-79 | | |
| A | 272 | DMC | 3-18-79 | | |
| B | 301 | DMC | 5-31-79 | | |
| C | 655 | B-1 | 3-27-81 | | |
| D | 801 | AAA | 10-28-81 | | |
| E | 936 | M.B. | 1-13-82 | | |

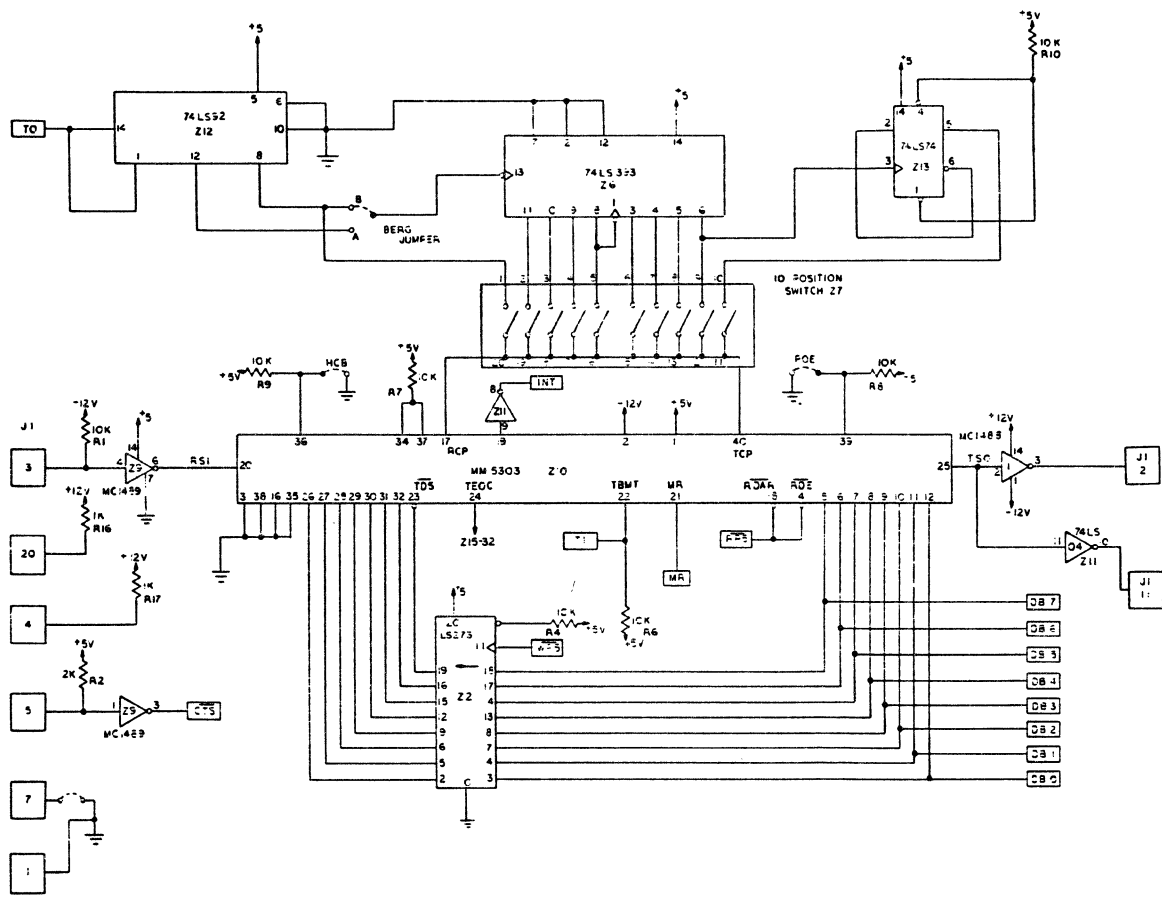

| QTY | ITEM | PART NO. | DESCRIPTION | REV |
|----------------------------|------|----------|------------------------|-------|
| | | | PARTS LIST | |
| OWN BY: | DMC | 2-12-79 | MATERIAL | |
| CHECK: | | | | |
| ENG: | | | FINISH | |
| OPT. SUP: | | | | |
| UNLESS OTHERWISE SPECIFIED | | | CODE UNIT | SCALE |
| DIMENSIONS ARE IN INCHES | | | LOGIC DIA, RW, BOARD, | |
| AND TOLERANCES ARE: | | | BIT PAD CNE CONTRALLER | |
| .015 .010 .005 .002 | | | (RS232 OPTION) | |
| .001 .0005 .0002 .0001 | | | D C6-CC11 | |
| DO NOT SCALE DRAWING | | | SITE SHEET 2 OF 3 | |

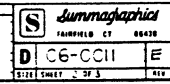

8 7 6 5 4 3 2 1

| REV. | NO. | DATE | BY | CHKD. |
|------|-----|----------|------|-------|
| 1 | 1 | 10/27/98 | J.P. | J.P. |
| 2 | 2 | 11/10/98 | J.P. | J.P. |
| 3 | 3 | 11/10/98 | J.P. | J.P. |
| 4 | 4 | 11/10/98 | J.P. | J.P. |
| 5 | 5 | 11/10/98 | J.P. | J.P. |
| 6 | 6 | 11/10/98 | J.P. | J.P. |
| 7 | 7 | 11/10/98 | J.P. | J.P. |
| 8 | 8 | 11/10/98 | J.P. | J.P. |

REVISION

REV. NO. DATE BY CHKD.

1 10/27/98 J.P. J.P.

2 11/10/98 J.P. J.P.

3 11/10/98 J.P. J.P.

4 11/10/98 J.P. J.P.

5 11/10/98 J.P. J.P.

6 11/10/98 J.P. J.P.

7 11/10/98 J.P. J.P.

8 11/10/98 J.P. J.P.

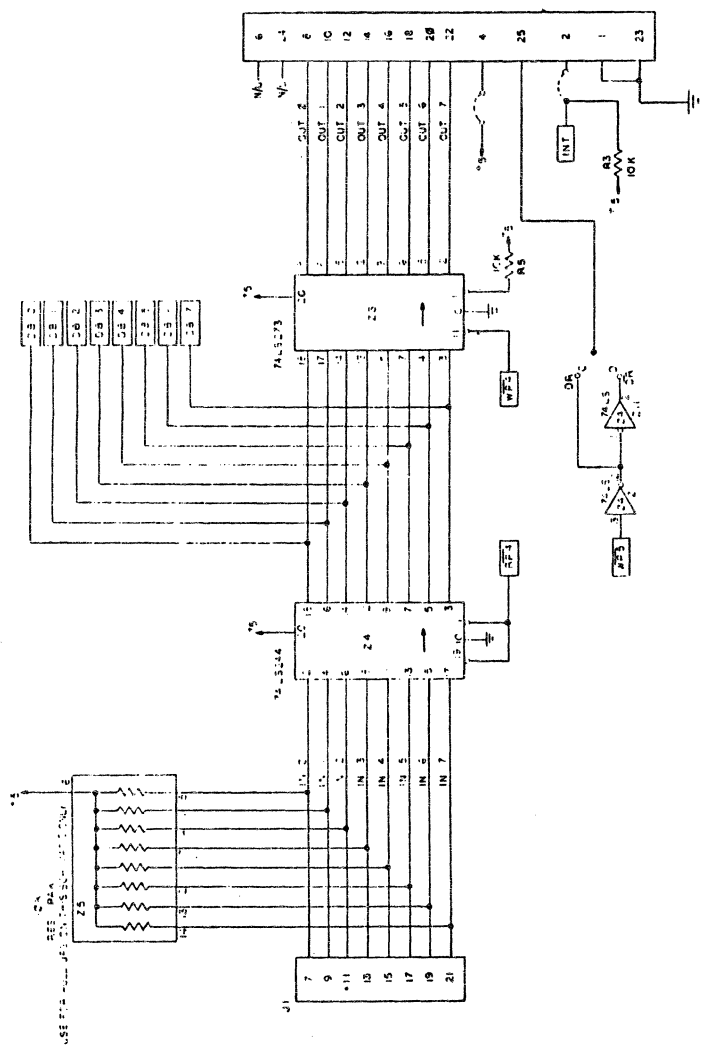

| ITEM NO. | DESCRIPTION | QTY |
|----------|-------------|-----|
| 1 | 74LS244 | 1 |
| 2 | 74LS273 | 1 |
| 3 | 10K | 2 |
| 4 | 0.1UF | 1 |
| 5 | 5V | 1 |

| REV. | NO. | DATE | BY | CHKD. |
|------|-----|----------|------|-------|
| 1 | 1 | 10/27/98 | J.P. | J.P. |
| 2 | 2 | 11/10/98 | J.P. | J.P. |
| 3 | 3 | 11/10/98 | J.P. | J.P. |
| 4 | 4 | 11/10/98 | J.P. | J.P. |
| 5 | 5 | 11/10/98 | J.P. | J.P. |
| 6 | 6 | 11/10/98 | J.P. | J.P. |
| 7 | 7 | 11/10/98 | J.P. | J.P. |
| 8 | 8 | 11/10/98 | J.P. | J.P. |

DESIGNED BY: J.P.

CHECKED BY: J.P.

DATE: 11/10/98

SCALE: 1:1

APPROVED BY: J.P.

DATE: 11/10/98

74LS244

74LS273

10K

0.1UF

5V

10K

0.1UF

5V

10K

0.1UF

5V

10K

0.1UF

5V

10K

0.1UF

5V

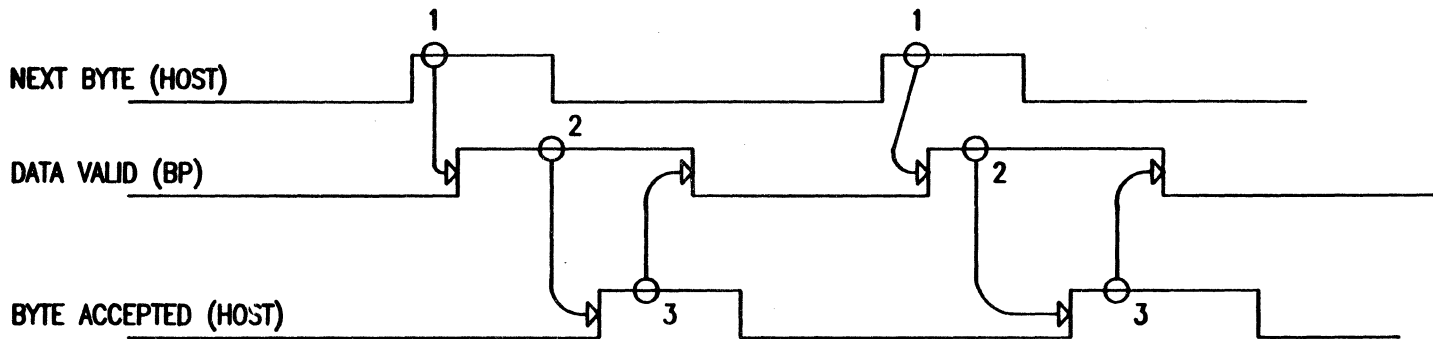

NEXT BYTE AND BYTE ACCEPTED ARE NEVER TRUE. COINCIDENTLY FOR PROPER CONTROL.

-37-

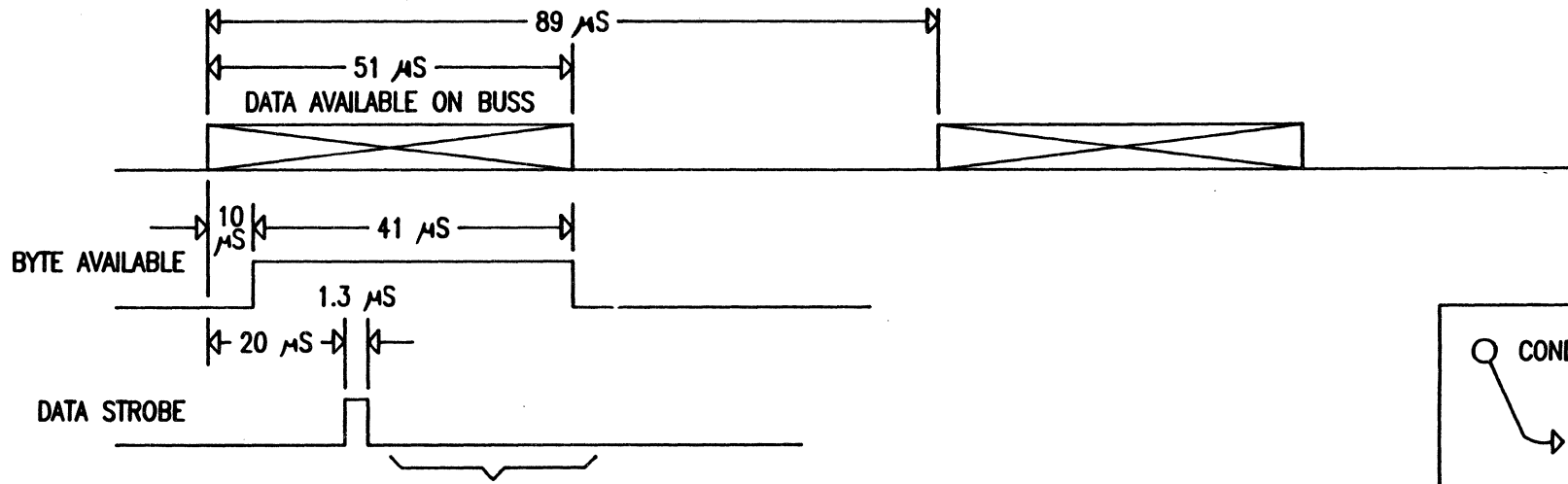

TIME INTERVAL MAY BE EXTENDED BY BYTE ACCEPTED BEING FALSE

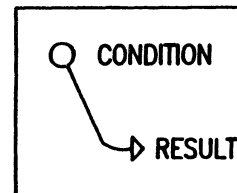

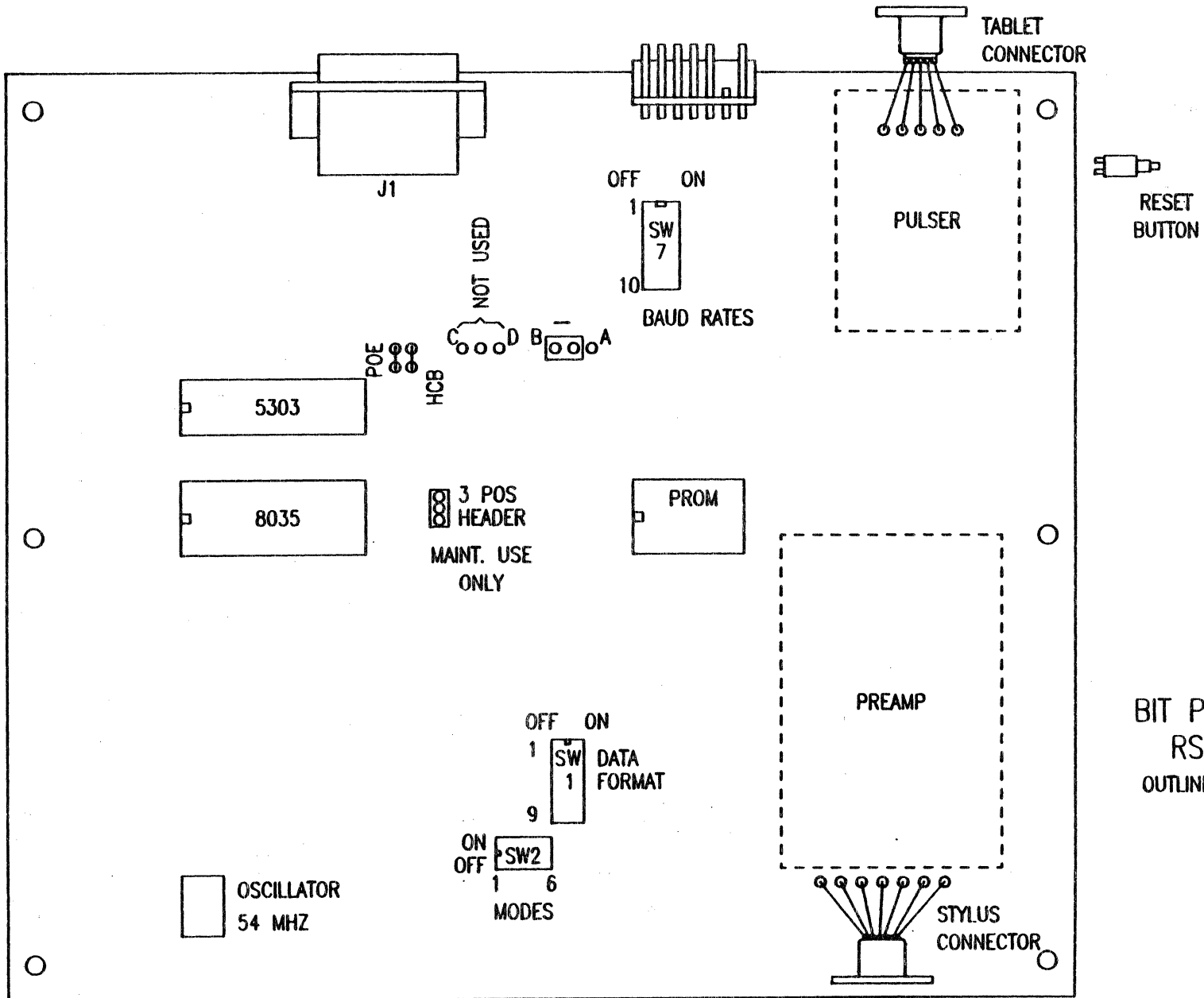

BIT PAD ONE
RS 232
OUTLINE DRAWING

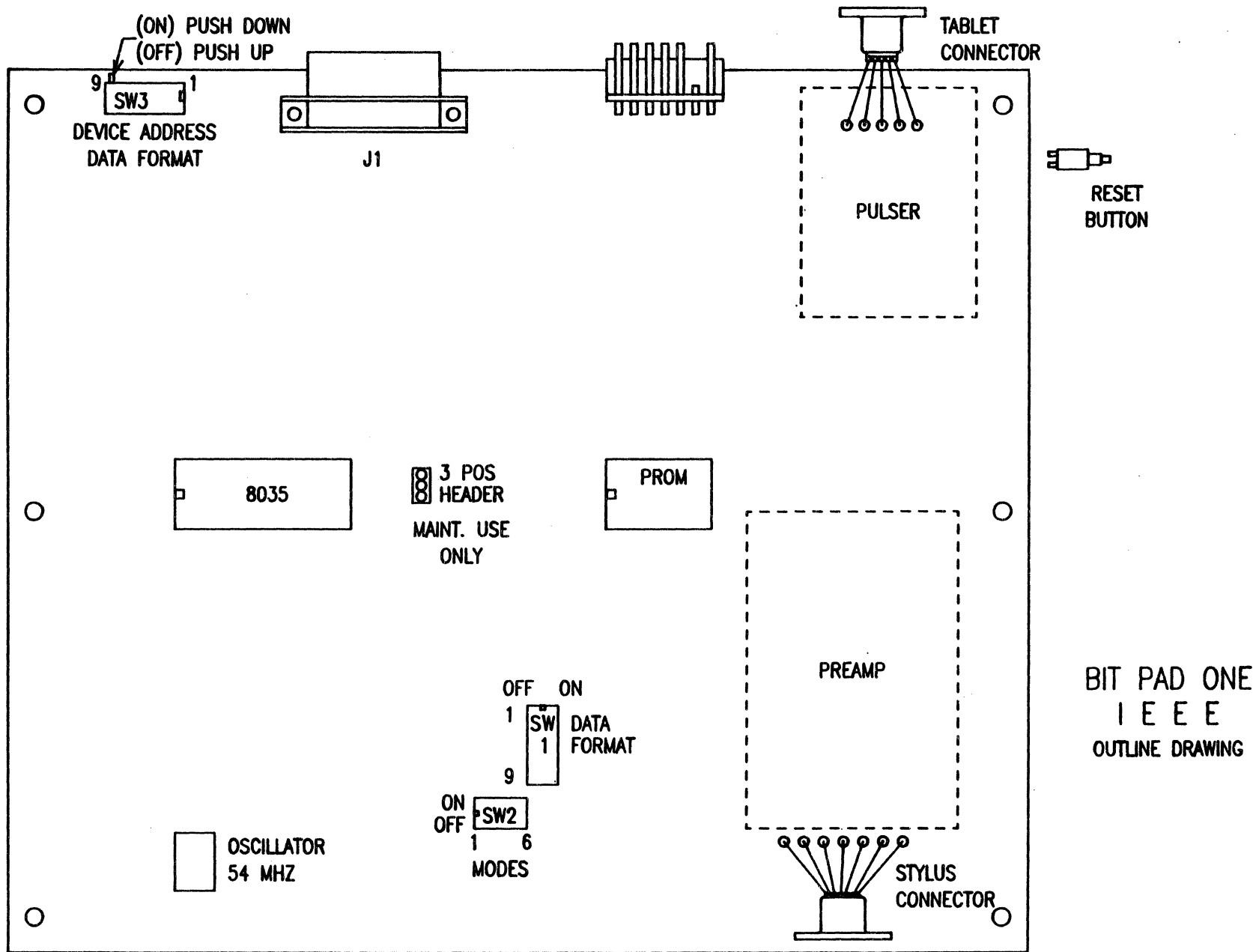

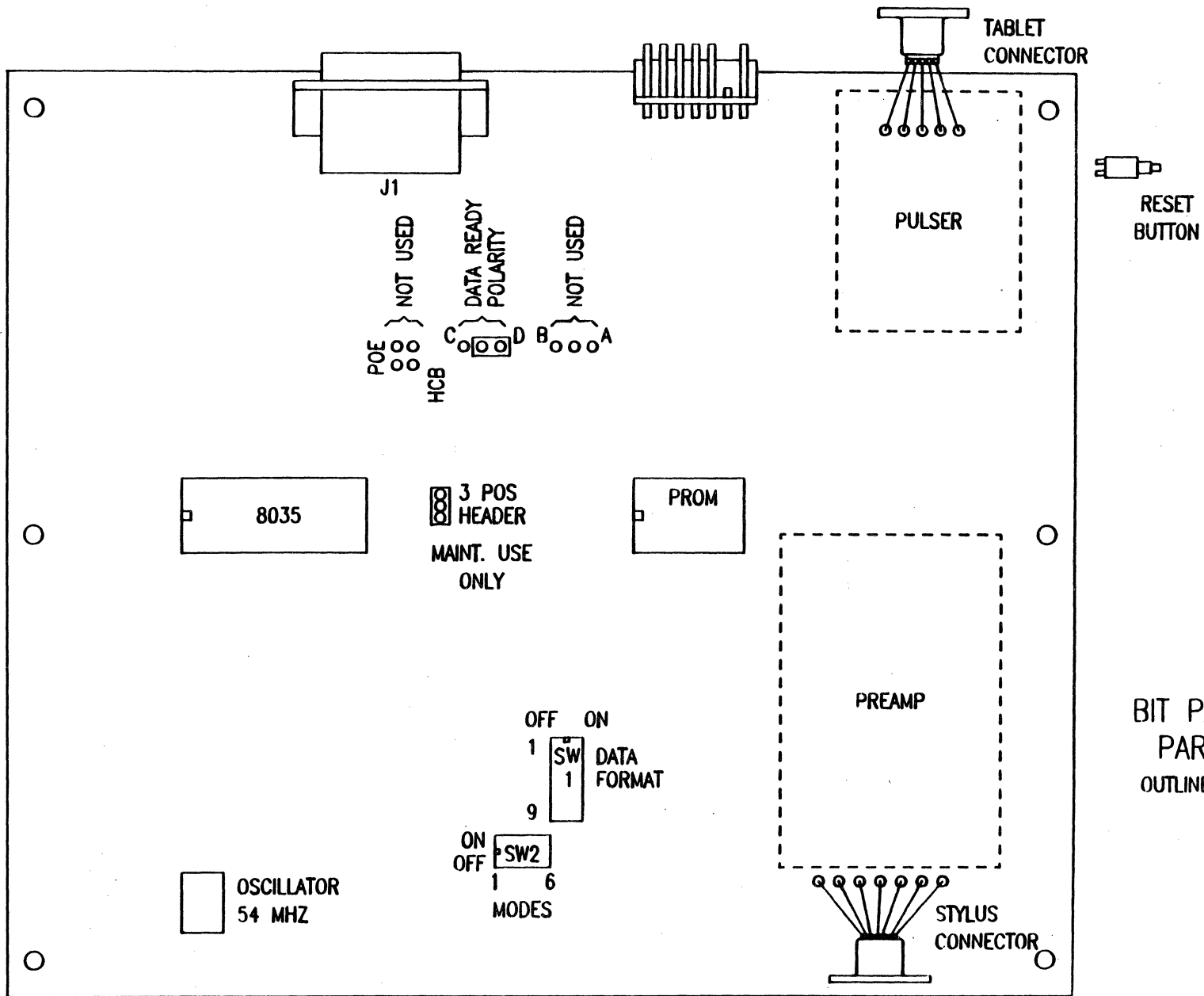

BIT PAD ONE
PARALLEL
OUTLINE DRAWING



Summagraphics
corporation

35 BRENTWOOD AVE., BOX 781, FAIRFIELD, CONNECTICUT 06430, PHONE 203-384-1344
TELEX 964348

NOTICE

Form #90

BIT PAD ONE

RS232 UNITS SWITCH AND STRAP SETTINGS

Effective October 1, 1979, all Bit Pad One internal switches and straps will be factory set. All RS232 units will be set as follows: in the English mode, with BCD ASCII output, in the continuous stream mode at maximum sampling rate, at 9600 baud, with even parity and two stop bits.

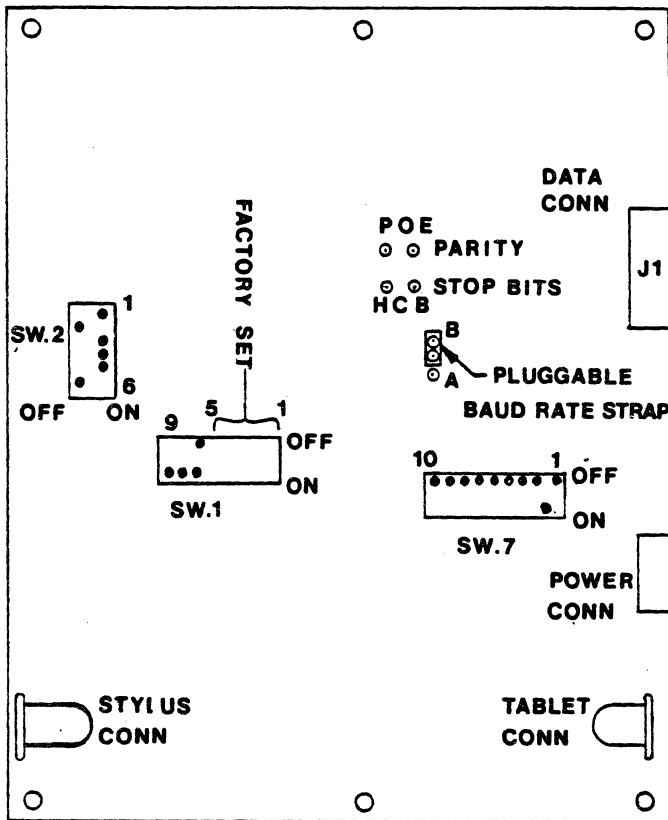

**RS 232 LOGIC
BOARD OUTLINE**

PLUGGABLE BAUD RATE STRAP OPTION A-B
Set in B position. (Strap over center pin and B pin.) Creates 9,600 Baud Rate when SW-7 position 2 is on.

PARITY
Even (No strap in POE Jumper Position)

STOP BITS
Two (No strap in HCB Jumper Position)

See Bit Pad Manual, Form 64, Rev. A 8/79, RS232 Section for complete information on Formats, Modes and Baud Rates available

SW-1 DATA FORMAT

- 1 } Factory Calibration
- 2 } Do Not Adjust
- 3 }
- 4 }
- 5 }
- 6 (Spare - Not Used)
- 7 OFF, BCD ASCII
- 8 ON, Carriage Return Line Feed (CRLF)
- 9 ON, English (0.005" Res.)

METRIC MODE

To set unit in Metric Mode, turn SW-1 Position 9 to OFF.

SW-2 SAMPLING MODE & REP RATE

- 1 ON } Continuous Stream Mode
- 2 OFF }
- 3 ON }
- 4 ON } Maximum Sampling Rate
- 5 ON }
- 6 OFF (Spare - Not Used)

REMOTE MODE

Unit is set in the Continuous Stream Mode at the maximum sampling rate to facilitate easy checkout. To set in Remote Programmable Mode, set SW-2 all position to OFF.

SW-7 BAUD RATE (only one position may be on at a time)

- 1 OFF (19,200 if ON and B strap)
- 2 ON 9,600 Baud & B Strap Position
- 3 OFF (4,800 if ON and B strap)
- 4 OFF (2,400 if ON and B strap)
- 5 OFF (1,200 if ON and B strap)
- 6 OFF (600 if ON and B strap)
- 7 OFF (300 if ON and B strap)
- 8 OFF
- 9 OFF
- 10 OFF



Summagraphics
corporation

35 BRENTWOOD AVE., BOX 761, FAIRFIELD, CONNECTICUT 06430, PHONE 203-384-134
TELEX 9643

NOTICE
BIT PAD ONE

Form # 91

PARALLEL UNITS SWITCH AND STRAP SETTINGS

Effective October 1, 1979, all Bit Pad One internal switches and straps will be factory set. All Parallel units will be set as follows: in the English mode, with parallel binary output, in the continuous stream mode at a rate of 200 points per second, and with a negative-going data ready pulse.

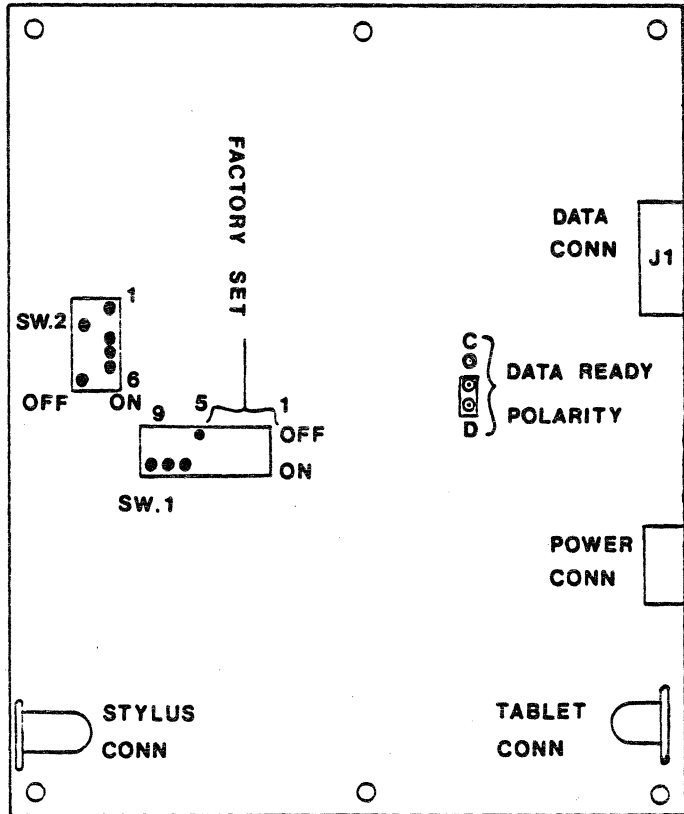

PARALLEL LOGIC
BOARD OUTLINE

SW-1 DATA FORMAT

- 1 } Factory Calibration
- 2 } Do Not Adjust
- 3 }
- 4 }
- 5 }
- 6 (Spare - Not Used)
- 7 ON, Parallel Binary Output
(No CRLF transmitted when in this position)
- 8 ON, CRLF
- 9 ON, English (0.005" Res.)

METRIC MODE

To set unit in Metric Mode, turn SW-1 Position 9 to OFF.

SW-2 SAMPLING MODE & REP RATE

- 1 ON } Continuous Stream Mode
- 2 OFF }
- 3 ON }
- 4 ON } Maximum Sampling Rate
- 5 ON }
- 6 OFF (Spare - Not Used)

REMOTE MODE

Unit is set in the Continuous Stream Mode at the maximum sampling rate to facilitate easy checkout. To set in the Remote Programmable Mode, set SW-2 all positions to OFF.

POLARITY OF DATA STROBE (CD STRAP)

Unit is set in the D position with a negative-going data ready pulse. To change to positive pulse, place plug-gable strap over center pin and C pin.

Set Bit Pad Manual, Form 64, Rev. A 8/7
Parallel Section for complete information on Formats, Modes and Rates available.



Summagraphics
corporation

35 BRENTWOOD AVE., BOX 781, FAIRFIELD, CONNECTICUT 06430, PHONE 203-384-1344
TELEX 964348

NOTICE

Form #92

BIT PAD ONE

IEEE UNITS SWITCH AND STRAP SETTINGS

Effective October 1, 1979, all Bit Pad One internal switches and straps will be factory set. All IEEE units will be set as follows: in the English mode, in the continuous stream mode at maximum sampling rate, with Device 8-address, no Service Request and Tektronix GPIB format.

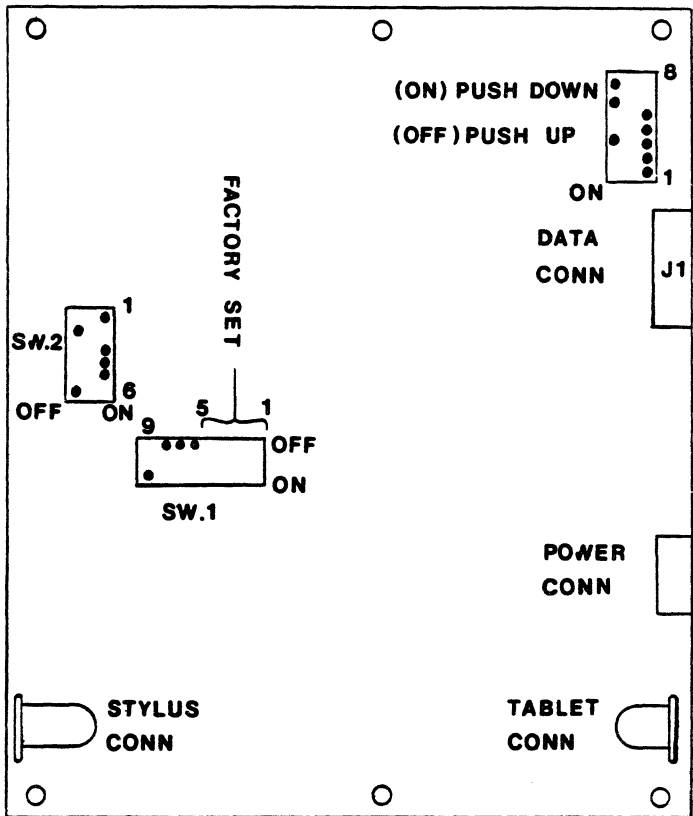

IEEE LOGIC
BOARD OUTLINE

SW-1 DATA FORMAT

- 1 } Factory Calibration
- 2 } Do Not Adjust
- 3 } Do Not Adjust
- 4 } Do Not Adjust
- 5 } Do Not Adjust
- 6 ON = ID Format/*OFF = BP Format
- 7 } (Spares - Not Used)
- 8 } (Spares - Not Used)
- 9 ON, English (0.005" Res.)

METRIC MODE

To set unit in Metric Mode, turn SW-1 Position 9 to OFF.

SW-2 SAMPLING MODE & REP RATE

- 1 ON } Continuous Stream Mode
- 2 OFF } Continuous Stream Mode
- 3 ON } Maximum Sampling Rate
- 4 ON } Maximum Sampling Rate
- 5 ON } Maximum Sampling Rate
- 6 OFF (Spare - Not Used)

REMOTE MODE

Unit is set in the Continuous Stream Mode at the maximum sampling rate to facilitate easy checkout. To set in Remote Programmable Mode, set SW-2 all positions to OFF.

SW-3 FORMAT ADDRESS

- 1 OFF, ADDR1 (1) LSB
- 2 OFF, ADDR2 (2)
- 3 OFF, ADDR3 (4)
- 4 ON, ADDR4 (8)
- 5 OFF, ADDR5 (16) MSB
- 6 OFF, Service Request (SRQ)
- 7 ON, Form 1
- 8 ON, Form 2

See Bit Pad Manual, Form 64, Rev. B 1/80, IEEE Section for complete information on Formats, Modes and Rates available.



Hitachi Seiko, Ltd.

HICOMSCAN HDG-1111
DATA GRAPHIC SYSTEM
USER'S MANUAL

Hitachi Seiko, Ltd.

Kanagawa, Japan

Contents

| | Page |
|---------------------------------------|------|
| 1. General description | 1 |
| 2. Components and connectors | 2 |
| 3. I/O ports | 5 |
| 3.1 RS-232C ports (serial port) | 5 |
| 3.2 Current loop output | 9 |
| 3.3 Parallel port | 9 |
| 3.4 I/O port selection | 12 |
| 4. XY coordinate data formats | 14 |
| 4.1 ASCII format | 14 |
| 4.2 Binary format | 16 |
| 5. Operating modes | 18 |
| 5.1 Resolution | 18 |
| 5.2 Output mode | 18 |
| 5.3 Output speed (RATE) | 19 |
| 6. Lamps and buzzer | 21 |
| 7. Command input | 23 |
| 8. DIP switch settings | 28 |
| 9. B format | 30 |
| 10. Cursor (option) | 33 |
| 11. Menu and T/M | 34 |
| 12. Specifications | 37 |

1. General description

The HICOMSCAN HDG-1111 DATA GRAPHIC SYSTEM is a high performance, high stable tablet digitizer designed to read digital data from any kind of drawings. It is most suited to an input device through which graphic data are input to a computer, and is usable in many other application areas.

Features:

(1) High accuracy

A stylus pen or cursor has an accuracy of ± 0.01 ", and thus ensures a highly accurate operation regardless of the tablet dimensions.

(2) Lightweight

Compact structure with a built-in controller requires a smaller space.

(3) Easy maintenance

A built-in microprocessor checks the hardware to permit easy maintenance.

(4) Absolute digitisation

Origin remains held where it is even if a cursor or pen is lifted off the tablet.

(5) High stability

Electromagnetic induction feature permits stable operation impervious to external factors such as wind, temperature, humidity, noise or vibration.

(6) Noise resistance

Noise resisting characteristic enables the system to be used as a computer terminal.

2. Components and connectors

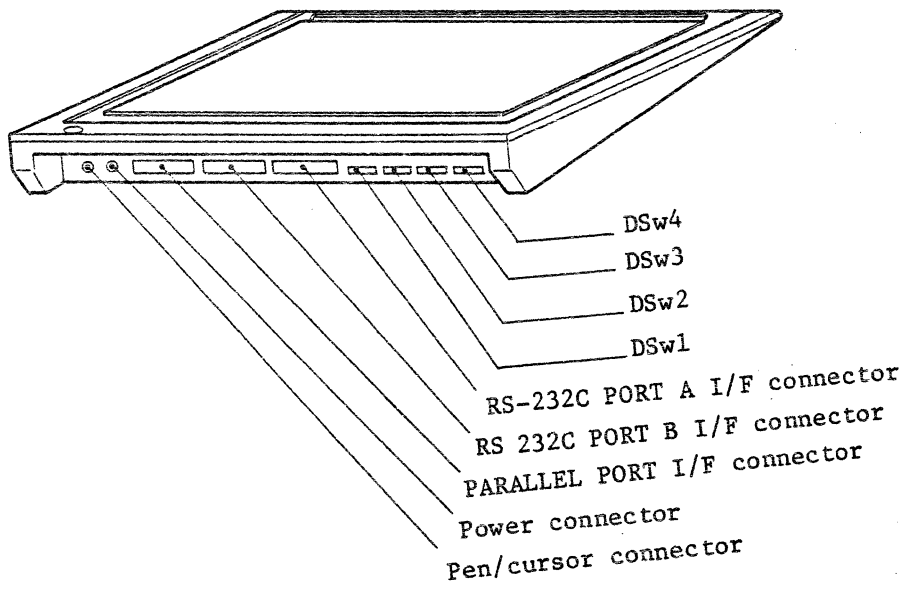
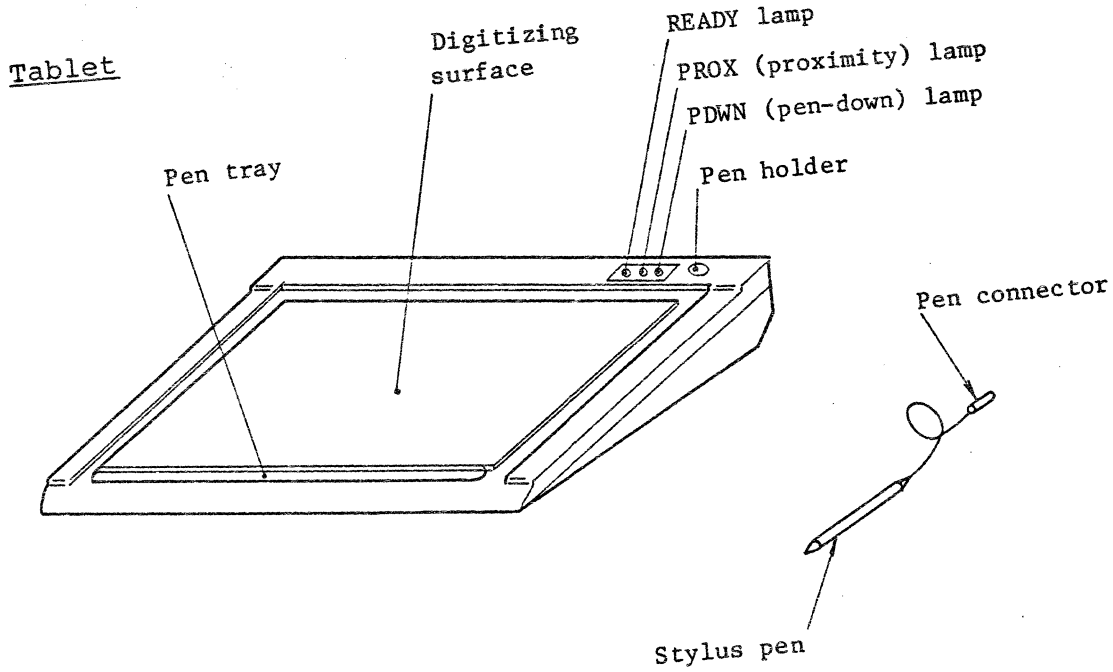

NOTE: Use a neutral cleaning agent for cleaning the tablet surface. Organic solvent may discolor or distort the tablet.

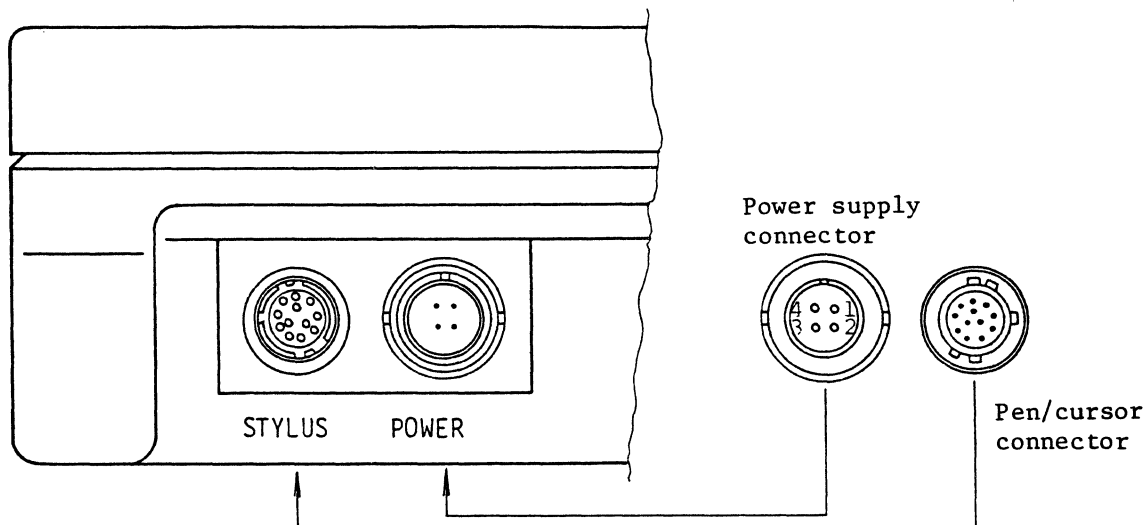

Pen/cursor connector

To plug in the connector, hold the connector shell by hand, turn the shell until it fits into the socket marked STYLUS on the tablet, and then push it straight into the socket. To disconnect, hold the shell by hand, and pull it straight toward you. Do not pull out the connector by pulling on the cable.

Power supply connector : HIROSE RM12BPG-4S (cable's side)

- PIN 1 : +5V 1A
- 2 : +12V 0.2A
- 3 : GROUND (common)
- 4 : -12V 0.2A

To plug in the connector, hold the connector shell by hand, turn it until it fits into the socket on the tablet, and then push it straight into the socket. Upon completion, be sure to turn the shell clockwise to lock it.

Stylus pen

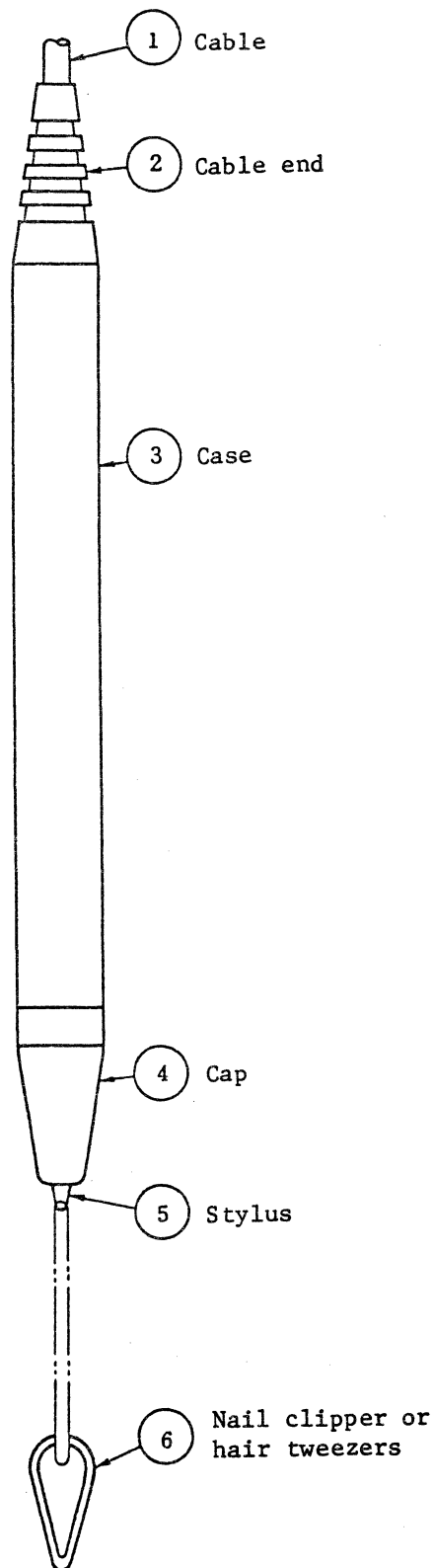

Stylus replacement procedure

- (1) Pull out the existing stylus with a nail clipper or hair tweezers.
- (2) Insert a new stylus properly into the cap.
- (3) Make sure that the stylus is clamped tightly and will not drop.

CAUTION

- (1) If the stylus is inserted improperly, digitizing operation cannot be made properly. Be sure to insert the stylus to the extreme end (or until it is pushed into the pen). If the stylus is pushed in too strongly, the pen may be broken.
- (2) Do not pull on the cable, nor bend the cable end.
- (3) Do not tap an object with the stylus pen.

3. I/O ports

3.1 RS-232C ports (serial port)

Two bi-directional half-duplex RS-232C ports are available. Pins are arranged so that Port A is configured as a modem, and Port B as a terminal. The difference between the modem and terminal configurations is that all lines on the same pin number have reversed roles as regards input/output, or, e.g., Pin No. 2 (Transmit Data) of Port A (modem) is for data input while the same number pins of Port B (terminal) is for data output. Table 3.1 shows the pin assignments.

Connectors

AMP206584-1 and DB-25P (cable side)

Before plugging in the connector, determine whether it is to be connected to Port A or B taking into account the following items.

- (1) Type of external device port (modem configuration or terminal configuration)
- (2) Type of connecting cable (direct type for modem-to-terminal connection or cross type for terminal-to-terminal connection)

For example, if the cross type cable is used for connecting a CRT display to the HDG-1111, the cable connector should be plugged into the Port B.

Table 3.1 RS-232C port pin assignments

| Pin No. | Signal name | J1 port A | J2 port B |
|---------|-------------|-----------|-----------|
| 1 | PG | GROUND | GROUND |
| 2 | TD | input | output |
| 3 | RD | output | input |
| 4 | RTS | input | output |
| 5 | CTS | output | input |
| 6 | DSR | output | input |
| 7 | SG | GROUND | GROUND |
| 8 | DCD | output | input |
| 20 | DTR | input | output |
| 15 | TSET* | NC | input |
| 17 | RSET** | NC | input |
| 18 | 20mA out | output | NC |
| 25 | 20mA return | GROUND | NC |

NC : Not to be connected

* Transmitting clock pulse for synchronous mode

** Receiving clock pulse for synchronous mode

Single port operation mode

Data output/command input can be made through selected one of the RS-232C ports. Any data input through the other port will be ignored. Meaningless data or invalid commands input to the selected port are also ignored.

Dual port operation mode

Both the RS-232C Ports A and B are effective in this mode. Either of these ports selected by the PORTA/PORT B selector switch (Port A when DSW2-2 is ON, Port B when DSW2-2 is OFF) or main Port selection command is called main port, and the other is subport.

XY coordinate data is transmitted from the both ports if the subport is enabled by turning OFF the DSW2-1, and is output only from the main port if the subport is disabled. Commands are input to the HDG-1111 only from the main port.

Data transfer between PORT A-PORT B is a unique feature of the dual port operation mode. All data input to the subport will be transferred to the main port before being transmitted.

Among the data sent to the main port, those other than command data are transferred to the subport before being transmitted. The command data are 02 HEX for stop-data-output, 04 HEX for resume-data-output, and 01 HEX followed by two ASCII characters.

The data transfer between the input and output will results in a delay of approximately 0.1 ms.

RS-232C character composition

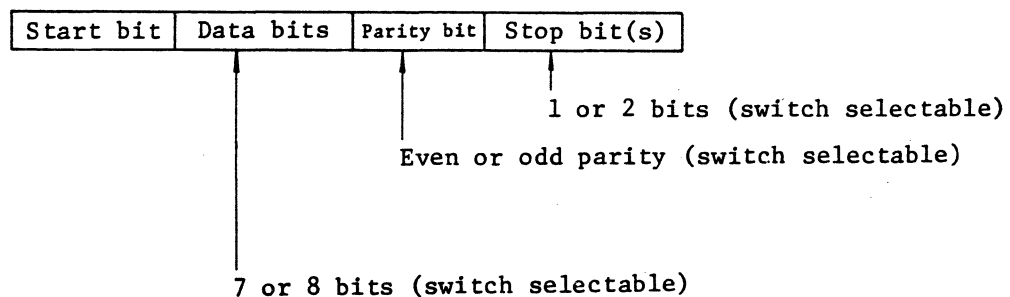

Table 3.2

| Data bit | Parity | Stop bit | DSW2-4 | DSW2-5 | DSW2-6 |
|----------|--------|----------|--------|--------|--------|
| 7 | EVEN | 2 | OFF | OFF | OFF |
| 7 | ODD | 2 | OFF | OFF | ON |
| 7 | EVEN | 1 | OFF | ON | OFF |
| 7 | ODD | 1 | OFF | ON | ON |
| 8 | NONE | 2 | ON | OFF | OFF |
| 8 | NONE | 1 | ON | OFF | ON |
| 8 | EVEN | 1 | ON | ON | OFF |
| 8 | ODD | 1 | ON | ON | ON |

Asynchronous mode (DSW1-2 must be OFF)

Table 3.3 Baud rate selection

| Baud rate | DSW1-3 | DSW1-4 | DSW1-5 | DSW1-6 | DSW1-7 | DSW1-8 |
|-----------|--------|--------|--------|--------|--------|--------|
| 19200 | OFF | OFF | ON | OFF | OFF | OFF |
| 9600 | OFF | OFF | OFF | ON | OFF | OFF |
| 4800 | OFF | OFF | OFF | OFF | ON | OFF |
| 2400 | ON | OFF | ON | OFF | OFF | OFF |
| 1200 | ON | OFF | OFF | ON | OFF | OFF |
| 600 | ON | OFF | OFF | OFF | ON | OFF |
| 300 | ON | ON | ON | OFF | OFF | OFF |
| 150 | ON | ON | OFF | ON | OFF | OFF |
| 75 | ON | ON | OFF | OFF | ON | OFF |
| 110 | OFF | ON | OFF | OFF | OFF | ON |

Synchronous mode (DSW1-2 must be ON)

Synchronizing clock pulse input pins are available on the Port B.

3.2 Current loop output

20 mA data output is available on the RS-232C Port A. The data is output simultaneously with the output from the RS-232C Port A (pin 3).

Pin 18 of Port A is current source, and Pin 25 is current return (GROUND). Logic 1 indicates 20 mA, and logic 0 is 0 mA.

Load : 0 ~ 350 ohms

3.3 Parallel port

8 bit wide TTL level parallel input/output port is available.

Connectors

AMP 306584-1 (25 pins) and DB-25P or equivalent (cable side)

Table 3.4 shows the pin assignment.

Table 3.4 Pin assignment

| Pin No. | Signal Name | I/O | Function |
|---------|-----------------|-----|--------------------|
| 1 | GROUND | — | INPUTDATA — STROBE |
| 2 | pDiSTRB | I | — |
| 3 | N.C. | — | — |
| 4 | +5V(strappable) | O | |
| 5 | N.C. | — | — |
| 6 | PDiACCEPTBL | O | |
| 7 | PDi0 | I | INPUT DATA (LSB) |
| 8 | PDO0 | O | OUTPUT DATA (LSB) |
| 9 | PDi1 | I | INPUT DATA |
| 10 | PDO1 | O | OUTPUT DATA |
| 11 | PDi2 | I | INPUT DATA |
| 12 | PDO2 | O | OUTPUT DATA |
| 13 | PDi3 | I | INPUT DATA |
| 14 | PDO3 | O | OUTPUT DATA |
| 15 | PDi4 | I | INPUT DATA |
| 16 | PDO4 | O | OUTPUT DATA |
| 17 | PDi5 | I | INPUT DATA |
| 18 | PDO5 | O | OUTPUT DATA |
| 19 | PDi6 | I | INPUT DATA |
| 20 | PDO6 | O | OUTPUT DATA |
| 21 | pDi7 | I | INPUT DATA (MSB) |
| 22 | PDO7 | O | OUTPUT DATA (MSB) |
| 23 | GROUND | — | |
| 24 | N.C. | — | |
| 25 | PDO STRB | O | OUTPUT DATA STROBE |

I: input pin
O: output pin

N.C. : No Connection

Parallel mode operation

When parallel mode is selected, input/output is made through the parallel port only. Any data input to the serial port will be ignored.

(1) Data output (handshaking)

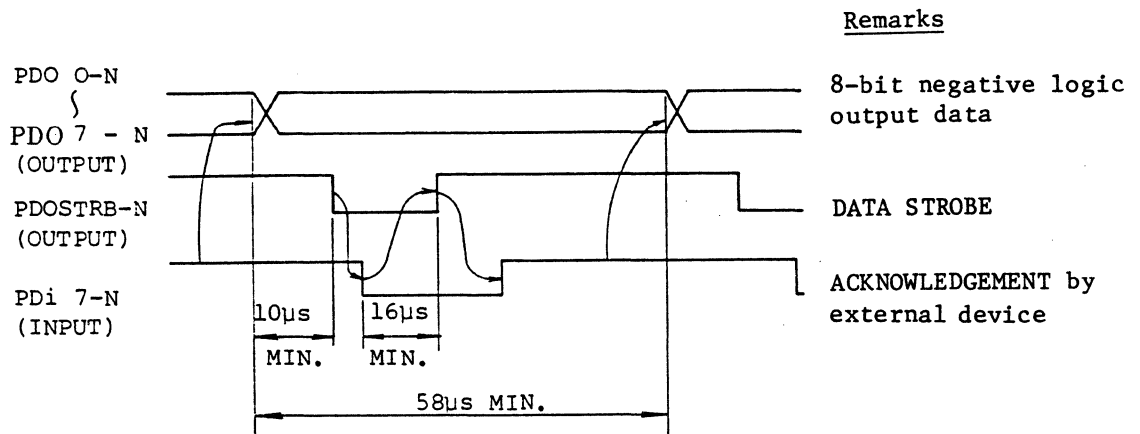

Fig. 3.3.1

NOTE: If handshaking is not used, PDOSTRB-N (pin 25) and PDi7-N (pin 21) should be shorted.

(2) Command input (handshaking)

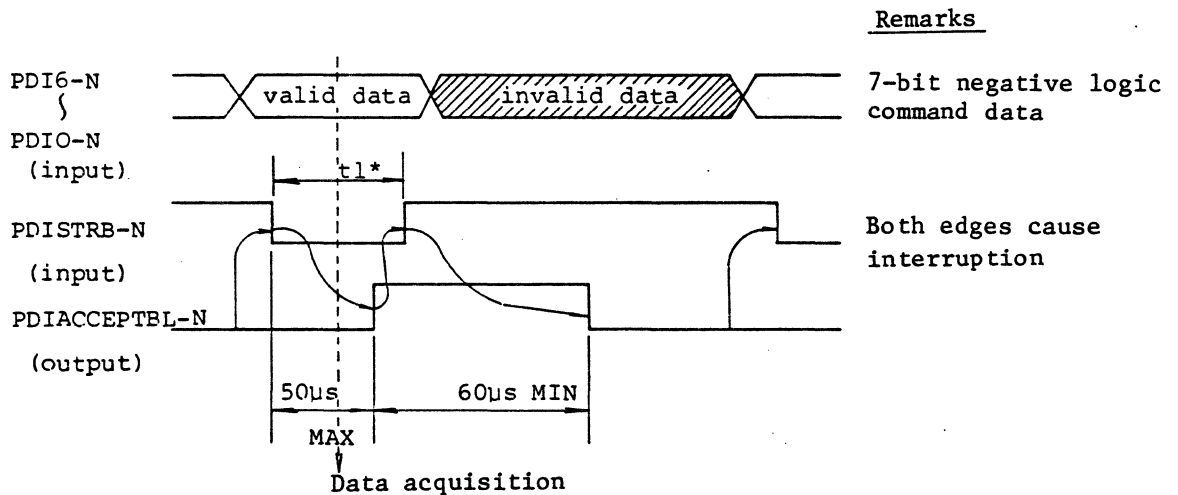

Fig. 3.3.2

* If handshaking is not required, t1 must be greater than 80 µs.

Serial mode operation

When serial mode is selected, XY coordinate data is also output through the parallel port. The output speed depends on the RS-232C baud rate.

Timing chart is shown in Fig. 3.3.3.

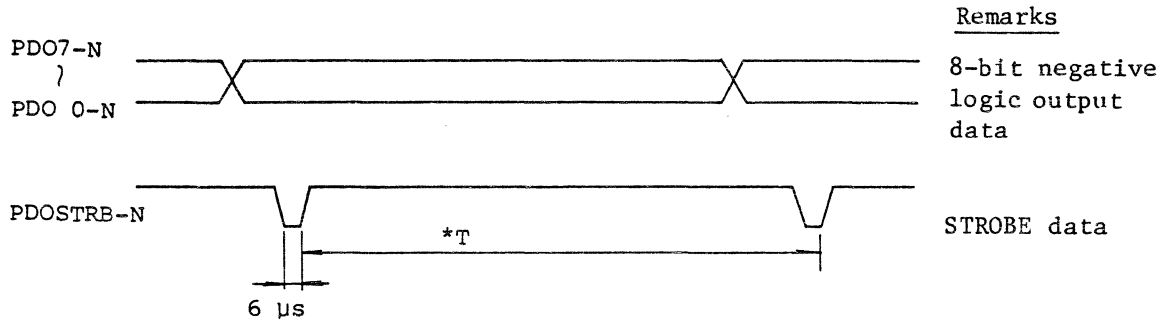

Fig. 3.3.3

* Approximately

$$T = \frac{\text{Number of character bits (switch selectable)}}{\text{Baud rate (switch selectable)}}$$

3.4 I/O port selection

At power on, I/O port(s) should be selected by DIP switches. Thereafter, selection should be made in accordance with I/O port select command.

Tables 3.5 and 3.6 show the relation between switch setting or command and I/O port function.

Table 3.5

| Selected Port Name | | | | Port Function | | |
|---------------------|-----------------|-------------------|-------------------------------|-----------------------------------|------------------|---|
| Serial/ Parallel | Single/ Dual | Port A/ Port B | Subport Enable/ Disable | XY Coordi- nate Data Output | Command Input | Data Trans- fer between Port A- Port B |
| ① Parallel | - | - | - | P | P | No |
| ② Serial | ③ Single | ⑤ Port A | - | A,P | A | No |
| | | ⑥ Port B | - | B,P | B | No |
| | ④ Dual | ⑤ Port A | ⑦ Enable | A,B,P | A | Yes |
| | | | ⑧ Disable | A,P | A | Yes |
| | | ⑥ Port B | ⑦ Enable | A,B,P | B | Yes |
| | | | ⑧ Disable | B,P | B | Yes |

A : RS-232C Port A

B : RS-232C Port B

P : Parallel Port

Table 3.6

| No. | DIP switch | Command | Function |
|-----|------------|---------|-----------------|
| ① | DSW1-1 ON | PA | Parallel mode |
| ② | DSW1-1 OFF | SR | Serial mode |
| ③ | DSW2-1 OFF | SN | Single port |
| ④ | DSW2-1 ON | DU | Dual port |
| ⑤ | DSW2-2 ON | QA | Port A |
| ⑥ | DSW2-2 OFF | QB | Port B |
| ⑦ | DSW2-3 OFF | SE | Subport enable |
| ⑧ | DSW2-3 ON | SK | Subport disable |

4. XY Coordinate data formats

4.1 ASCII format

S 99999, S 99999, F CR LF

① ② ③ ④ ⑤ ⑥ ⑦ ⑧ ⑨

① ④ Signs : Plus (+) or minus (-). At power on, No sign is attached. Signs will be output after the Set Origin Command is executed. They will not be output after the Return Origin Command is executed.

② X coordinate data

⑤ Y coordinate data

5 digits when 0.025mm or 0.001" resolution is selected

4 digits when 0.05mm, 0.1mm, 0.25mm, 0.0025", 0.005" or 0.01" resolution is selected.

If Leading Zero Suppression is set, the data length may be shortened. (When shortened, then ③, ⑥, and ⑦ are output to distinguish ② and ⑤ from each other.)

③ ⑥ Delimiter

⑦ Pendown code (31 HEX) or cursor function code

⑧ Carriage return

⑨ Line feed

Table 4.1 shows how to select function with ASCII-formatted data.

Table 4.1 How to select function with ASCII-formatted data

| Function name | Function | DIP switch | | Command |
|--|---|-----------------------------|--------|--------------|
| Code Selection Binary ASCII | Binary format ASCII format | DSW3-1 ON OFF | | BI AS |
| Leading Zero Sup- pression Yes No | ② and ⑤ are: Variable length Fixed length | DSW3-2 ON OFF | | LE LD |
| Function Code Output Yes No | ③, ⑥, and ⑦ are: Output Not output | DSW3-3 OFF ON | | PE PI |
| CR Code Output Yes No | ⑧ is: Output Not output | DSW3-4 OFF ON | | D1 D3 |
| LF Code Output Yes No | ⑨ is: Output Not output | DSW3-5 OFF ON | | D2 D4 |
| Set origin Set Return | ① and ④ are: Output Not output | | | FS FR |
| Resolution | | DSW3-7 | DSW3-8 | |
| 0.025mm or 0.001" | ② and ⑤ are 5 digits each | OFF | OFF | L1 |
| 0.05mm or 0.0025" | ② and ⑤ are 4 digits each | OFF | ON | L2 |
| 0.1 mm or 0.005" | ② and ⑤ are 4 digits each | ON | OFF | L3 |
| 0.25 mm or 0.01" | ② and ⑤ are 4 digits each | ON | ON | L4 |

4.2 Binary format

(1) High resolution packed binary format

(Applied to 0.025mm, 0.05mm, 0.001", or 0.0025" resolution)

| BIT BYTE | 7* | 6 | 5 | 4 | 3 | 2 | 1 | 0 |
|-------------|----|-----|-----|-----|-----|----|-----|-----|
| 1 | 1 | 0 | C3 | C2 | C1 | C0 | X15 | X14 |
| 2 | 0 | X13 | X12 | X11 | X10 | X9 | X8 | X7 |
| 3 | 0 | X6 | X5 | X4 | X3 | X2 | X1 | X0 |
| 4 | 0 | 0 | 0 | 0 | 0 | 0 | Y15 | Y14 |
| 5 | 0 | Y13 | Y12 | Y11 | Y10 | Y9 | Y8 | Y7 |
| 6 | 0 | Y6 | Y5 | Y4 | Y3 | Y2 | Y1 | Y0 |

* RS-232C port(s) does not output BIT 7 when 7-data bits character is selected.

C3 ~ C0 Pen-down code (0001 binary) or cursor function button code. 0000 binary means no actuation of the pen or cursor switch.

X15 ~ X0 X coordinate data

Y15 ~ Y0 Y coordinate data

(2) Low resolution packed binary format

(Applied to 0.1mm, 0.25mm, 0.005", or 0.01" resolution)

| BIT BYTE | 7 | 6 | 5 | 4 | 3 | 2 | 1 | 0 |
|-------------|---|---|-----|-----|----|----|----|----|
| 1 | P | 1 | C3 | C2 | C1 | C0 | 0 | 0 |
| 2 | P | 0 | X5 | X4 | X3 | X2 | X1 | X0 |
| 3 | P | 0 | X11 | X10 | X9 | X8 | X7 | X6 |
| 4 | P | 0 | Y5 | Y4 | Y3 | Y2 | Y1 | Y0 |
| 5 | P | 0 | Y11 | Y10 | Y9 | Y8 | Y7 | Y6 |

C3 ~ C0 Pen-down code (0001 binary) or cursor
 function button code.

X11 ~ X0 X coordinate data

Y11 ~ Y15 Y coordinate data

P Parity bit (even parity)
 RS-232C port(s) does not output this bit
 when 7-data bits character is selected.

Minus data of XY coordinate is expressed in terms of
two's complement when the "Set Origin" command has
been executed.

5. Operating modes

5.1 Resolution

Any of the following 8 resolutions is selectable.

0.025mm, 0.05mm, 0.1mm, 0.25mm

0.001", 0.0025", 0.005", 0.01"

Table 5.1 shows how to select a resolution.

Table 5.1 Selection of resolution

| DIP switch setting | | | | |
|--------------------|------------|---------|---------|----|
| DSW3 -7 | DSW3 -8 | DSW4-1 | | |
| | | OFF | ON | |
| OFF | OFF | 0.025mm | 0.001" | L1 |
| | ON | 0.05m | 0.0025" | L2 |
| ON | OFF | 0.1mm | 0.005" | L3 |
| | ON | 0.25mm | 0.01" | L4 |
| | | MT | IN | |
| Command | | | | |

NOTE: At power ON, select a resolution by using a DIP switch.
Thereafter, select it with command.

5.2 Output mode

The following 4 modes are provided.

POINT ----- Data for one point only will be output when the pen or cursor switch is actuated.

TRACK ----- Data will be output continuously while the pen or cursor switch is actuated.

RUN ----- Data will be output continuously while the pen or cursor is on the approach to the tablet.

INCREMENTAL ----- Data will be output when the movement of the pen or cursor in the X/Y direction is above 10 times greater than the set resolution. The INCREMENTAL mode is invalid in the POINT mode.

5.3 Output speed (RATE)

Any of the following output speeds is selectable
1 (fastest), 1/2, 1/4, 1/10, 1/20, 1/40, 1/100, 1/200
(Switch or command selectable)

RATE controls the minimum output period of XY coordinate data in the TRACK or RUN mode. In the INCREMENTAL mode, XY coordinate data will be output only when the following two conditions are met; (1) incremented data has been detected, and (2) the period set by RATE selection has elapsed.

RS-232C dual port data transfer requires to extend the period.

RS-232C baud rate may limit the output speed regardless of whether the speed has been selected by RATE.

Table 5.2 shows how to set a RATE.

Table 5.2 How to set rate

| RATE \ Setting | DIP switch | | | Command |
|----------------|------------|--------|--------|---------|
| | DSW4-5 | DSW4-6 | DSW4-7 | |
| 1 | OFF | OFF | OFF | R1 |
| 1/2 | OFF | OFF | ON | R2 |
| 1/4 | OFF | ON | OFF | R3 |
| 1/10 | OFF | ON | ON | R4 |
| 1/20 | ON | OFF | OFF | R5 |
| 1/40 | ON | OFF | ON | R6 |
| 1/100 | ON | ON | OFF | R7 |
| 1/200 | ON | ON | ON | R8 |

The maximum speed is 200 XY points/second.*

* When Parallel port, Binary format, 0.025mm resolution and RATE 1 are selected and J3 21 pin and 25 pin is shorted (i.e. handshaking is killed).

6. Lamps and buzzer

Lamps

Three status indicator LED's are mounted on the tablet.

READY ----- Indicates that power is ON and the initial self-diagnosis has been successfully completed.

PROX ----- Indicates that either the pen or cursor (PROXIMITY) has detected coordinates in the active area of the tablet.

PDWN ----- Indicates that the pen or cursor switch (PEN DOWN) has been actuated. This lamp is effective only when the PROX lamp is ON.

Buzzer

Table 6.1 Buzzer functions

| No. | Buzzer function | Buzzer sounds when/at: | Duration of buzzing | Description |
|-----|------------------------|---|--|-------------|
| 1 | Pen-down Detection | Pen-down or cursor button has been depressed | 200 ms × 1 time | |
| 2 | Command Receiving | Command has been received | 50 ms × 1 time | |
| 3 | Bell Command Receiving | Command T1 has been received T2 has been received T3 has been received T4 has been received | 200 ms × 1 time × 2 times × 3 times × 4 times | |

(Cont'd)

| No. | Buzzer function | Buzzer sounds when/at: | Duration of buzzing | Description |
|-----|-----------------------|--|--|--|
| 4 | RS-232C Port Alarm | 1. Power ON | 400 ms × 5 times | Main port connector has not been plugged in, or external device has not been energized. |
| | | 2. Command RS | | |
| | | 3. Start of digitizing mode* | | |
| | | *(DSW2-8 turned OFF from ON) | 400 ms × 10 times | Subport connector has not been plugged in, or external device has not been energized (in dual mode). |
| | | | 400 ms × 15 times | Main port and subport connectors have not been plugged in, or external devices have not been energized (in dual mode). |
| 5 | Input Buffer Overflow | Data transfer between RS-232C ports | Intermittent buzzing at interval of 200 ms until power is turned OFF | Data being transferred between ports have overflowed |
| 6 | Switch-set Self Test | Several seconds after setting T/M mode (DSW2-8 turned ON from OFF) | 200 ms × 1 time | ROM NG |
| | | | 400 ms × 1 time | ROM OK |
| | | | 200 ms × 4 times | RAM NG |
| | | | 400 ms × 2 times | RAM OK |

The buzzer is enabled/disabled by switch or command.

Table 6.2

| | DIP switch | Command |
|------------------|------------|---------|
| Buzzer enable | DSW3-6 OFF | AE |
| * Buzzer disable | DSW3-6 ON | AD |

* The buzzer can be disabled only for Pen-down, command receiving, and bell command receiving (commands T1 through T4 receiving).

7. Command input

On-line command input

On-line command data is input through a selected port to change the existing operation mode.

(1) One character commands

Stop Data Output ----- 02 HEX

Resume Data Output ----- 04 HEX

Note that data will be continuously transferred between the RS-232C ports, and commands are also received while the "Stop Data Output" command is running.

(2) Three-character commands

Header 01HEX is followed by two ASCII characters.

Table 7.1 shows all three-character commands, but headers are omitted in it. Some of these commands will be briefed below. Most of them are described in other sections.

Set origin (or Floating Zero) : 01HEX FS

Upon receipt of this command (01HEX FS), the origin of the next XY coordinate can be set at any point on the active area of the tablet by touching the desired point with the pen or cursor and then actuating the pen or cursor switch. Thereafter, plus (+) or minus (-) sign is added when it is output in ASCII format, or 2's complement binary data is output as a minus data in case of binary format.

Return Origin : 01HEX FR

Upon receipt of this command, the origin set by the "Set Origin" command is canceled, and it returns to the initial position (left bottom corner of the active area on the tablet) which has been set at power ON. Thereafter, all XY coordinate data are set positive with no sign bit character.

Self Test : 01HEX DT

ROM and RAM are tested, and the results are answered back through the main port.

ASCII "0" is output when both ROM and RAM are OK.

ASCII "N" is output when ROM and/or RAM are NG.

"Stop Data Output" command should be input before starting the self test.

The HDG-1111 repeatedly performs self test and outputs the respective results until it receives "End of Self-Test" command (01HEX DR).

Table 7.1 Commands (without header)

| | Command | Code | Remarks |
|---|--------------------------------|------|---|
| 1 | Reset | RS | Settings are made by DIP switches. |
| 2 | Stop Data Output | SD | Commands are received, and data are transferred between ports even after this command is set. |
| 3 | Resume Data Output | RD | |
| 4 | | | |
| 5 | Select Point Mode | PT | |
| | Select Track Mode | LN | |
| | Select Run Mode | CN | |
| | | | |
| 6 | Select Incremental Data Output | IC | |
| | Reset Incremental Data Output | IR | |
| 7 | Select Inch Data Output | IN | |
| | Select Metric Data Output | MT | |
| 8 | 0.025mm/0.001" Resolution | L1 | |
| | 0.05mm/0.0025" Resolution | L2 | |
| | 0.1mm/0.005" Resolution | L3 | |
| | 0.25mm/0.01" Resolution | L4 | |
| 9 | Select Data Rate: 1 | R1 | (Fastest rate) |
| | 1/2 | R2 | |
| | 1/4 | R3 | |
| | 1/10 | R4 | |
| | 1/20 | R5 | |
| | 1/40 | R6 | |
| | 1/100 | R7 | |
| | 1/200 | R8 | (slowest rate) |

(Cont'd)

| | Command | Code | Remarks |
|----|------------------------------|------|---|
| 10 | Set Origin | FS | |
| | Return Origin | FR | Origin returns to the initial position. |
| 11 | Self-Test | DT | ASCII "0" is output when ROM/RAM is OK. ASCII "N" is output when ROM/RAM is NG. |
| | End of Self-Test | DR | |
| 12 | Enable Buzzing | AE | Buzzer will sound. |
| | Disable Buzzing | AD | Buzzer will not sound (alarm will sound). |
| 13 | Buzz Once | T1 | 200 ms × 1 time |
| | Buzz Twice | T2 | 200 ms × 2 times |
| | Buzz 3 Times | T3 | 200 ms × 3 times |
| | Buzz 4 Times | T4 | 200 ms × 4 times |
| 14 | Select ASCII Format Output | AS | |
| | Select Packed Binary Output | BI | |
| 15 | Include Function Code | PE | Pen-down code/cursor function button code |
| | Exclude Function Code | PI | |
| 16 | Include Carriage-Return Code | D1 | When ASCII format is selected. |
| | Include Line-Feed Code | D2 | When ASCII format is selected. |
| | Exclude Carriage-Return Code | D3 | When ASCII format is selected. |
| | Exclude Line-Feed Code | D4 | When ASCII format is selected. |
| 17 | Suppress Leading Zero | LE | Leading zero(s) is not output when ASCII format is selected. (Data is of variable length.) |
| | Include Leading zero | LD | Leading zero(s) is output when ASCII format is selected. (Data is of fixed length.) |

(Cont'd)

| | Command | Code | Remarks |
|----|------------------------------------|------|-------------------------------|
| 18 | Select Parallel Port | PA | |
| | Select RS-232C (Serial) Port(s) | SR | |
| | Select Single-Port- Mode | SN | When serial mode is selected. |
| | Select Dual-Port Mode | DU | When serial mode is selected. |
| | Select Port A as Main Port | QA | When serial mode is selected. |
| | Select Port B as Main Port | QB | When serial mode is selected. |
| | Enable Subport | SE | When dual mode is selected. |
| | Disable Subport | SK | When dual mode is selected. |

8. DIP switch setting

All mode selections should be made by DIP switches at power ON or immediately after "Reset" (RS) command has been executed. Once a command other than the RS is input, then a mode is selected by the command.

Baud-rate will be changed as soon as the DIP switches for setting baud-rate are altered because the switches directly control circuits, but the alternation of other switches becomes available by turning off and then on the power or turning on and then off DSW2-8.

Dip switches functions are summarized in next page.

ON
OFF



Table 8.1 DIP switch functions

| | | | | | | | | | | | | | | | |
|---|------|--|-------------------|-----------------|------|------|------|-----|-----|-----|-----|-----|-----|-----|-----|
| 1 | DSW1 | SERIAL/PARALLEL | OFF: Serial | ON: Parallel | | | | | | | | | | | |
| 2 | | ASYNC/SYNC | OFF: Asynchronous | ON: Synchronous | | | | | | | | | | | |
| 3 | | B A U D R A T E | D S W 1 | ③ | OFF | OFF | OFF | ON | ON | ON | ON | ON | OFF | | |
| 4 | | | | ④ | OFF | OFF | OFF | OFF | OFF | OFF | ON | ON | ON | ON | |
| 5 | | | | ⑤ | ON | OFF | OFF | ON | OFF | OFF | ON | OFF | OFF | OFF | OFF |
| 6 | | | | ⑥ | OFF | ON | OFF | OFF | ON | OFF | OFF | ON | OFF | OFF | OFF |
| 7 | | | | ⑦ | OFF | OFF | ON | OFF | OFF | ON | OFF | OFF | ON | OFF | OFF |
| 8 | | | | ⑧ | OFF | OFF | OFF | OFF | OFF | OFF | OFF | OFF | OFF | OFF | ON |
| | | BAUD | 19200 | 9600 | 4800 | 2400 | 1200 | 600 | 300 | 150 | 75 | 110 | | | |

| | | | | | | | | | | | | | | |
|---|------|----------------------------------|---------------|-------------|-----|------|-----|------|------|------|-----|----|-----|----|
| 1 | DSW2 | SINGLE/DUAL | OFF: Single | ON: Dual | | | | | | | | | | |
| 2 | | PORT B/PORT A | OFF: Port B | ON: Port A | | | | | | | | | | |
| 3 | | SUBPORT ENABLE/DISABLE | OFF: Enable | ON: Disable | | | | | | | | | | |
| 4 | | } RS-232C WORD COMPOSITION | DSW-2 | OFF | OFF | ON | OFF | ON | OFF | ON | OFF | ON | OFF | ON |
| 5 | | | ④⑤⑥ | BIT | 7 | 7 | 7 | 7 | 8 | 8 | 8 | 8 | | |
| 6 | | | PARITY | Even | Odd | Even | Odd | None | None | Even | Odd | | | |
| 7 | | OFF (must-be) | STOP BIT | 2 | 2 | 1 | 1 | 2 | 1 | 1 | 1 | | | |
| 8 | | DIGITIZE/TEST | OFF: Digitize | ON: T & M | | | | | | | | | | |

| | | | | | | | |
|---|------|---|--|-------------|----------------|--------|-------|
| 1 | DSW3 | ASCII/BINARY | OFF: ASCII | ON: Binary | | | |
| 2 | | LEADING ZERO SUPPRESSION | OFF: No | ON: Yes | | | |
| 3 | | FUNCTION CODE OUTPUT | OFF: Yes | ON: No | | | |
| 4 | | C/R CODE OUTPUT | OFF: Yes | ON: No | | | |
| 5 | | L/F CODE OUTPUT | OFF: Yes | ON: No | | | |
| 6 | | BUZZER | OFF: Enable | ON: Disable | | | |
| 7 | | } RESOLU- ... OFF } 0.025mm OFF } 0.05mm ON } 0.1mm ON } 0.25mm | TION ... OFF } or ON } or OFF } or ON } or | 0.001" | 0.0025" | 0.005" | 0.01" |
| 8 | | | | (sounding) | (not sounding) | | |

| | | | | | | | | | | | |
|---|------|------------------------|-------------|--------------------|------------|-----|-----|-----|-----|----|----|
| 1 | DSW4 | UNIT SELECTION | OFF: METRIC | ON: ENGLISH (INCH) | | | | | | | |
| 2 | | } MODE SELECTION | OFF } RUN | OFF } TRACK | ON } POINT | | | | | | |
| 3 | | | OFF } ON | ON } OFF | ON } ON | | | | | | |
| 4 | | INCREMENTAL MODE | OFF: NORMAL | ON: INCREMENTAL | | | | | | | |
| 5 | | } RATE SELECTION | RATE SW | | | | | | | | |
| 6 | | | ⑤ | OFF | OFF | OFF | OFF | ON | ON | ON | ON |
| 7 | | | ⑥ | OFF | OFF | ON | ON | OFF | OFF | ON | ON |
| 8 | | ⑦ | OFF | ON | OFF | ON | OFF | ON | OFF | ON | |
| | | MENU ENABLE | OFF: NORMAL | ON : MENU | | | | | | | |

9. B format

Data will be output in B format if the DSW2-7 is set to ON at power ON. The output and command formats of the HDG-1111 are compatible with those of the BIT PAD ONE manufactured by Summagraphics Corp. in the U.S.A. The functions of DIP switches (in B format) are shown in Table 9.1 (page 32).

Port selection

One of the parallel ports RS-232C port A or port B can be selected by the DSW1-1 and DSW2-2, and data-output/command-input is made through the selected port only. When serial I/F is selected, for example, then XY coordinate data are output in the single mode, and input data are not transferred between the ports.

RS-232C Word Composition

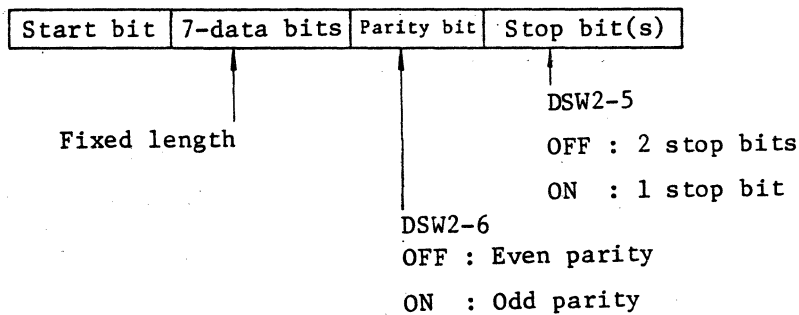

Command input

Commands can be input only when REMOTE mode is set by the turning ON the DSW4-2 and DSW4-3.

Mode selection

Table 9.2 shows the terms used with the HDG-1111 and BIT PAD ONE.

Table 9.2 Terms Used with HDG-1111 and BIT PAD ONE

| | |
|--------------------|----------|
| BIT PAD ONE | HDG-1111 |
| POINT MODE | POINT |
| STREAM MODE | RUN |
| SWITCH STREAM MODE | TRACK |
| Remote Control | REMOTE |

Remote control

If REMOTE mode is set by turning ON the DSW4-2 and DSW4-3, the HDG-1111 stops outputting data at power ON, and a command, if input, causes only the XY coordinate data to be output.

Resolution Selection

To make the output and command formats compatible with those of the BIT PAD ONE, a resolution of 0.1 mm or 0.005" should be selected by turning ON the DSW3-7 and turning OFF the DSW3-8.

Cursor Button Code Selection (when using a cursor)

The DSW2-1 is used to output a code equivalent to the 4-button/13-button of the BIT PAD ONE.

Data Strobe Signal on Parallel Port

The DSW3-3 enables you to select a positive logic/negative logic.

Table 9.1 DIP switch functions (when data are output in B format) [DSW2-7 : ON]

ON
OFF

| | | | | | | | | | | | | | | | | | | | | | | | | | | | | | | | | | | | | | | | | | | | | | | | | | | | | | | | | | | | | | | | | | | | | | | | | | | | | | | | | | | | | | | | | | | | |
|------|------|-------------------------------|-------------------|--|-------|-------|-----|-----|-----|----|-----|----|----|----|----|----|----|----|--|--|---|--|--|--|--|--|----|----|----|----|--|--|---|----|--|--|----|--|--|----|--|--|--|--|---|--|----|--|--|----|--|--|----|--|--|--|---|--|--|----|--|--|----|--|--|----|--|--|---|--|--|--|--|--|--|--|--|--|----|------|--|-------|-------|-------|-------|-------|-----|-----|-----|----|-----|
| 1 | DSW1 | SERIAL I/F/PARALLEL I/F | OFF: Serial | ON: Parallel | | | | | | | | | | | | | | | | | | | | | | | | | | | | | | | | | | | | | | | | | | | | | | | | | | | | | | | | | | | | | | | | | | | | | | | | | | | | | | | | | | | | | | | |
| 2 | | ASYNC/SYNC | OFF: Asynchronous | ON: Synchronous | | | | | | | | | | | | | | | | | | | | | | | | | | | | | | | | | | | | | | | | | | | | | | | | | | | | | | | | | | | | | | | | | | | | | | | | | | | | | | | | | | | | | | | |
| 3 | | DSW1 | D S W 1 | <table border="1" style="width: 100%; border-collapse: collapse;"> <tr> <td style="width: 5%;"></td> <td style="width: 5%;">3</td> <td style="width: 5%;"></td> <td style="width: 5%;"></td> <td style="width: 5%;"></td> <td style="width: 5%;">ON</td> <td style="width: 5%;">ON</td> <td style="width: 5%;">ON</td> <td style="width: 5%;">ON</td> <td style="width: 5%;">ON</td> <td style="width: 5%;">ON</td> <td style="width: 5%;"></td> </tr> <tr> <td></td> <td>4</td> <td></td> <td></td> <td></td> <td></td> <td></td> <td>ON</td> <td>ON</td> <td>ON</td> <td>ON</td> <td></td> </tr> <tr> <td></td> <td>5</td> <td>ON</td> <td></td> <td></td> <td>ON</td> <td></td> <td></td> <td>ON</td> <td></td> <td></td> <td></td> </tr> <tr> <td></td> <td>6</td> <td></td> <td>ON</td> <td></td> <td></td> <td>ON</td> <td></td> <td></td> <td>ON</td> <td></td> <td></td> </tr> <tr> <td></td> <td>7</td> <td></td> <td></td> <td>ON</td> <td></td> <td></td> <td>ON</td> <td></td> <td></td> <td>ON</td> <td></td> </tr> <tr> <td></td> <td>8</td> <td></td> <td></td> <td></td> <td></td> <td></td> <td></td> <td></td> <td></td> <td></td> <td>ON</td> </tr> <tr> <td colspan="2" style="border-top: 1px solid black;">Baud</td> <td style="border-top: 1px solid black;">19200</td> <td style="border-top: 1px solid black;">9,600</td> <td style="border-top: 1px solid black;">4,800</td> <td style="border-top: 1px solid black;">2,400</td> <td style="border-top: 1px solid black;">1,200</td> <td style="border-top: 1px solid black;">600</td> <td style="border-top: 1px solid black;">300</td> <td style="border-top: 1px solid black;">150</td> <td style="border-top: 1px solid black;">75</td> <td style="border-top: 1px solid black;">110</td> </tr> </table> | | | | | 3 | | | | ON | ON | ON | ON | ON | ON | | | 4 | | | | | | ON | ON | ON | ON | | | 5 | ON | | | ON | | | ON | | | | | 6 | | ON | | | ON | | | ON | | | | 7 | | | ON | | | ON | | | ON | | | 8 | | | | | | | | | | ON | Baud | | 19200 | 9,600 | 4,800 | 2,400 | 1,200 | 600 | 300 | 150 | 75 | 110 |
| | | | | 3 | | | | ON | ON | ON | ON | ON | ON | | | | | | | | | | | | | | | | | | | | | | | | | | | | | | | | | | | | | | | | | | | | | | | | | | | | | | | | | | | | | | | | | | | | | | | | | | | | | | |
| | | | | 4 | | | | | | ON | ON | ON | ON | | | | | | | | | | | | | | | | | | | | | | | | | | | | | | | | | | | | | | | | | | | | | | | | | | | | | | | | | | | | | | | | | | | | | | | | | | | | | | |
| | | | | 5 | ON | | | ON | | | ON | | | | | | | | | | | | | | | | | | | | | | | | | | | | | | | | | | | | | | | | | | | | | | | | | | | | | | | | | | | | | | | | | | | | | | | | | | | | | | | | |
| | | | | 6 | | ON | | | ON | | | ON | | | | | | | | | | | | | | | | | | | | | | | | | | | | | | | | | | | | | | | | | | | | | | | | | | | | | | | | | | | | | | | | | | | | | | | | | | | | | | | |
| | | | | 7 | | | ON | | | ON | | | ON | | | | | | | | | | | | | | | | | | | | | | | | | | | | | | | | | | | | | | | | | | | | | | | | | | | | | | | | | | | | | | | | | | | | | | | | | | | | | | |
| | 8 | | | | | | | | | | ON | | | | | | | | | | | | | | | | | | | | | | | | | | | | | | | | | | | | | | | | | | | | | | | | | | | | | | | | | | | | | | | | | | | | | | | | | | | | | | | | |
| Baud | | 19200 | 9,600 | 4,800 | 2,400 | 1,200 | 600 | 300 | 150 | 75 | 110 | | | | | | | | | | | | | | | | | | | | | | | | | | | | | | | | | | | | | | | | | | | | | | | | | | | | | | | | | | | | | | | | | | | | | | | | | | | | | | | | |
| 4 | | | | | | | | | | | | | | | | | | | | | | | | | | | | | | | | | | | | | | | | | | | | | | | | | | | | | | | | | | | | | | | | | | | | | | | | | | | | | | | | | | | | | | | | | | | |
| 5 | | | | | | | | | | | | | | | | | | | | | | | | | | | | | | | | | | | | | | | | | | | | | | | | | | | | | | | | | | | | | | | | | | | | | | | | | | | | | | | | | | | | | | | | | | | |
| 6 | | | | | | | | | | | | | | | | | | | | | | | | | | | | | | | | | | | | | | | | | | | | | | | | | | | | | | | | | | | | | | | | | | | | | | | | | | | | | | | | | | | | | | | | | | | |
| 7 | | | | | | | | | | | | | | | | | | | | | | | | | | | | | | | | | | | | | | | | | | | | | | | | | | | | | | | | | | | | | | | | | | | | | | | | | | | | | | | | | | | | | | | | | | | |
| 8 | | | | | | | | | | | | | | | | | | | | | | | | | | | | | | | | | | | | | | | | | | | | | | | | | | | | | | | | | | | | | | | | | | | | | | | | | | | | | | | | | | | | | | | | | | | |

| | | | | | | |
|---|------|------------------------------------|-----------------------------|--|--------------------|--|
| 1 | DSW2 | CURSOR BUTTON CODE | OFF: 4-button code | | ON: 13-button code | |
| 2 | | SERIAL I/F PORT SELECTION | | | | |
| 3 | | (invalid) | OFF: Port B | | ON: Port A | |
| 4 | | (invalid) | | | | |
| 5 | | { SERIAL DATA TRANSFER } ... | OFF: 2 stop bits | | ON: 1 stop bit | |
| 6 | | { WORD COMPOSITION } ... | OFF: Even parity | | ON: Odd parity | |
| 7 | | | ON: BIT PAD COMPATIBLE MODE | | | |
| 8 | | T/M MODE SETTING | OFF: Normal (digitizing) | | ON: T/M | |

| | | | | | |
|---|------|--|---------------------------|----------------------------|------------------------|
| 1 | DSW3 | OUTPUT FORMAT | OFF: ASCII | ON: Binary | |
| 2 | | (invalid) | | | |
| 3 | | DATA STROBE IN CASE OF PARALLEL MODE | OFF: Positive logic | ON: Negative logic | |
| 4 | | (invalid) | | | |
| 5 | | WHEN ASCII FORMAT IS SELECTED | OFF: L/F code attached | ON: L/F code not attached | |
| 6 | | BUZZER | OFF: ENABLE (sounding) | ON: Disable (not sounding) | |
| 7 | | | | | |
| 8 | | { RESOLUTION } ... | OFF { 0.025mm or 0.001" } | OFF { 0.05mm or 0.0025" } | ON { 0.1mm or 0.005" } |

| | | | | | | |
|---|------|------------------------------|-------------|---------------|--------------|---------------|
| 1 | DSW4 | OUTPUT UNIT SELECTION | OFF: [mm] | ON: [inch] | | |
| 2 | | { MODE SELECTION } ... | OFF { RUN } | OFF { TRACK } | ON { POINT } | ON { REMOTE } |
| 3 | | (invalid) | | | | |
| 4 | | | | | | |
| 5 | | } OUTPUT RATE SELECTION | | | | |
| 6 | | | | | | |
| 7 | | | | | | |
| 8 | | (invalid) | | | | |

| | | | | | | | | | |
|------------------|---|----|-----|-----|------|------|------|-------|-------|
| D S W 4 | 5 | | | | | ON | ON | ON | ON |
| | 6 | | ON | ON | | | ON | ON | |
| | 7 | ON | | ON | | ON | | | ON |
| RATE | | 1 | 1/2 | 1/4 | 1/10 | 1/20 | 1/40 | 1/100 | 1/200 |

10. Cursor (option)

Set the cursor on the tablet so that the intersection of cursor lens cross-line is aligned with coordinate, and then depress the cursor buttons. These procedures enable the controller to issue PDWN signal.

10.1 12-button cursor

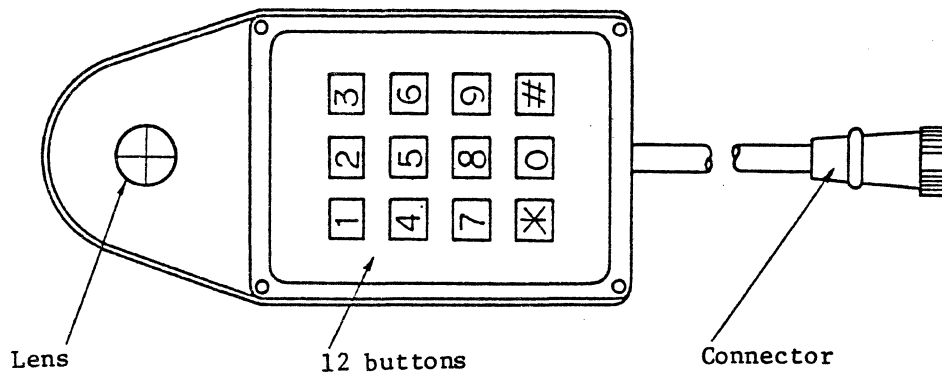

Table 10.1 Cursor button function codes

| Button identifier | ASCII output | BINARY output | | | |
|-------------------|--------------|----------------|----------------|----------------|----------------|
| | | C ₃ | C ₂ | C ₁ | C ₀ |
| 1 | 1 (31HEX) | 0 | 0 | 0 | 1 |
| 2 | 2 (32HEX) | 0 | 0 | 1 | 0 |
| 3 | 3 (33HEX) | 0 | 0 | 1 | 1 |
| 4 | 4 (34HEX) | 0 | 1 | 0 | 0 |
| 5 | 5 (35HEX) | 0 | 1 | 0 | 1 |
| 6 | 6 (36HEX) | 0 | 1 | 1 | 0 |
| 7 | 7 (37HEX) | 0 | 1 | 1 | 1 |
| 8 | 8 (38HEX) | 1 | 0 | 0 | 0 |
| 9 | 9 (39HEX) | 1 | 0 | 0 | 1 |
| * | * (2AHEX) | 1 | 0 | 1 | 0 |
| 0 | 0 (30HEX) | 1 | 0 | 1 | 1 |
| # | # (23HEX) | 1 | 1 | 0 | 0 |

11. Menu and T/M

11.1 Menu

If the POWER switch is turned ON with the DSW4-8 ON, the HDG-1111 is put in menu mode. As shown in Fig. 11.1, the active area of the tablet has dimensions of 10" (254mm) on the X axis × 11" (279.4mm) on the Y axis, and menu area is assigned at the leading portion of the tablet as wide as 1" on the X axis. Menu sheet is shown on the right side of this page.

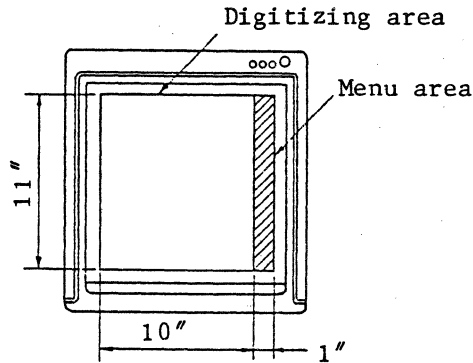

Fig. 11.1

Menu sheet setting procedure

- (1) Put the HDG-1111 in RUN mode.
- (2) Draw a line on the left edge of menu area on the tablet. When a pen or cursor is moved into the menu area, then the RUN mode automatically changes to POINT mode.
- (3) Place the menu sheet on the menu area so that the left edge of the sheet is aligned with the drawn line, and then fix the sheet with tapes.

The menu is usable in the following two modes.

1. COMMAND mode

Setting procedure:

Put down the pen to the CANCEL and then COMMAND MODE on the menu sheet. Once the COMMAND mode is set, as many commands as you want can be input.

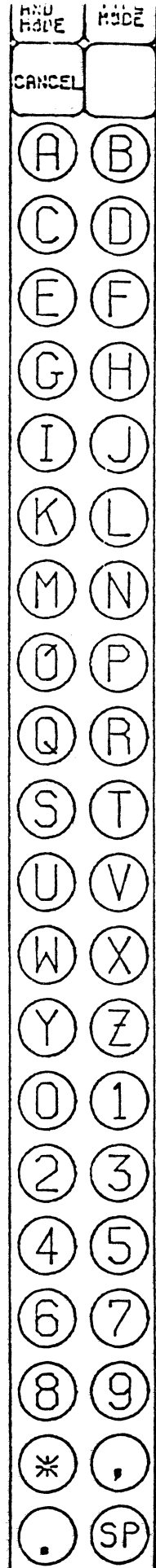

Command: 2 characters (see Table 7.1)

Put down the pen to the respective characters. If the first character is erroneously specified, put down the pen to the CANCEL and then COMMAND MODE to reset the COMMAND mode.

2. TYPE mode

In this mode, the characters specified by the pen will be output in ASCII format through the port set for XY coordinate data.

Setting procedure:

Put down the pen to the CANCEL and then TYPE MODE on the menu sheet.

Notes 1: Normal digitizing will be performed when the pen is put down to the digitizing area.

2: Menu sheet cannot be used when data are to be output in B format (DSW2-7 being ON).

3: The CANCEL on the menu sheet works to clear the COMMAND mode or TYPE mode when the pen is put down to it. If none of these modes has been set, no data will be output although the pen is put down to the menu sheet.

11.2 T/M (Test and Maintenance)

The HDG-1111 is put in TEST mode by turning ON the DSW2-8 to check the ROM and RAM. The test results are indicated by the buzzer. (Table 6.1)

NOTE: Be sure to set the DSW3-1 to OFF position before turning ON the DSW2-8.

The TEST mode automatically changes to DIGITIZE mode by turning OFF the DSW2-8. Once the DIGITIZE mode is set, the commands input previously will be all canceled, and thus settings should be made by the DIP switches.

12. Specifications

12.1 Performance

Resolution : 0.025, 0.05, 0.1, and 0.25 millimeter
0.001, 0.0025, 0.005, and 0.01 inch

Accuracy : ± 0.01 "

Effective
Readout area: 11 x 11 inches (279.4 mm x 279.4 mm)
(Active area)

Readout
speed : 200 points/sec (maximum)

Origin : Fixed at the bottom left corner of the
active area. It can be reset at any
desired position of the active area by
"Set Origin" command.

12.2 Operating mode

POINT, TRACK, RUN, and INCREMENTAL modes are settable

Self diagnosis : Set for testing ROM and RAM.

12.3 Environmental conditions

| Item | During operation | During standby | Remarks |
|-------------|----------------------------|------------------------------------|-------------------------|
| Temperature | 0 ~ 45°C | 0 ~ 60°C | |
| Humidity | 10 ~ 90% R.H | 10 ~ 95% R.H | No condensation allowed |
| Vibration | 0.25G or less | 2.5G or less | |
| Impact | 2G or less | 5G or less (during transportation) | |
| Dust | 1mg/m ³ or less | 1mg/m ³ or less | |

12.4 Power supply

+5V \pm 5% 1A (pin 1)

+12V \pm 5% 0.2A (pin 2)

-12V \pm 5% 0.2A (pin 4)

Common Ground (pin 3)

Connector: HIROSE RM12BPG-4S ----- cable side