

 **Disabled Village Children - A Guide for Community Health Workers, Rehabilitation Workers, and Families (Hesperian Foundation, 1999, 676 p.)**

 **PART 3: WORKING IN THE SHOP: Rehabilitation Aids and Procedures**

 **(introduction...)**

 **Chapter 56: Introduction to PART 3: Making Sure Aids and Procedures Do More Good than Harm**

 **Chapter 57: A 'Shop for Making Aids' Run by Disabled Villagers**

 **Chapter 58: Braces (Calipers)**

 **Chapter 59: Correcting Joint Contractures**

 **Chapter 60: Correcting Club Feet**

 **Chapter 61: Homemade Casting Materials**

 **Chapter 62: Developmental Aids**

 **Chapter 63: Walking Aids**

 **Chapter 64: Decisions about Special Seats and Wheelchairs**

 **Chapter 65: Adaptations for Wheelchairs and Other Sitting Aids**

 **Chapter 66: Designs for 6 Basic Wheelchairs**

 **Chapter 67: Artificial Legs**

Disabled Village Children - A Guide for Community Health Workers, Rehabilitation Workers, and Families (Hesperian Foundation, 1999, 676 p.)

PART 3: WORKING IN THE SHOP: Rehabilitation Aids and Procedures



Figure



A lot of 'shop work' can be done outside. Here young men in Kibwezi, Kenya (Africa) learn to make low-cost aids (Photo Aids for Living, AHRTAG)

Chapter 56: Introduction to PART 3: Making Sure Aids and Procedures Do More Good than Harm

When I (David Werner) was about 10 years old, I was taken to a doctor because I was having problems with my feet I kept falling over things and spraining my ankles. No one knew yet that these were early signs of a *progressive muscular atrophy*.

The doctor examined my feet. They were somewhat weak and floppy, so he prescribed arch supports. An 'orthotist' across town would make them

When the arch supports were ready, the orthotist put them on my feet "Do they hurt?" he asked 'No," I said. So I was sent home with instructions to wear them every day

I hated the things'-not because they hurt, but because it was harder for me to walk with them than without them. They pushed up on my arches and bent my ankles outward I fell and sprained my ankles more than ever

I tried to protest, but nobody listened to me. After all, I was only a child ` You have to get used to them'" I was told "Who do you think knows best-you or the doctor?"

So mostly I suffered in silence. I took the arch supports out of my shoes and hid them whenever I could. But when I was caught I was punished. I was made to feel naughty and guilty for not doing what was 'best' for me

Several years later, as my walking continued to get worse, I was prescribed a pair of metal braces. They held my ankles firmly, but they were heavy, uncomfortable, and made me feel more awkward than ever I hated them, but wore them because I was told to

One holiday I took a long walk in the mountains. The braces rubbed the skin on the front of my legs so badly that deep, painful sores developed I refused to wear them again

It was not until many years later, long after I had begun to work with *disabled* children, that a brace maker and I figured out what kind of ankle support would best meet my needs. So now I use lightweight, plastic braces that provide both the flexibility and support that best suit me

When I look back, I realize that the doctor did not know more about what I needed than I knew. After all, I was the one who lived with my feet' True, at age 10, I could not explain the mechanics and anatomy for what was happening. But I did have a sense of what helped me manage better and what did not. Maybe if the adults who were so eager to help had included me in deciding what I needed, I might have had aids that better met my needs. And I might not have felt so guilty and naughty for expressing my opinion

I learned something from these childhood experiences. I learned how important it is to listen to the disabled child, to ask the child at every stage how she feels about an aid or an exercise, and to include the child and her parents in deciding what she needs. The child and her parents may not always be right. But doctors, therapists, and *rehabilitation* workers are not always right either. By respecting each other's special knowledge and looking together for solutions, they can come closest to meeting the child's needs.

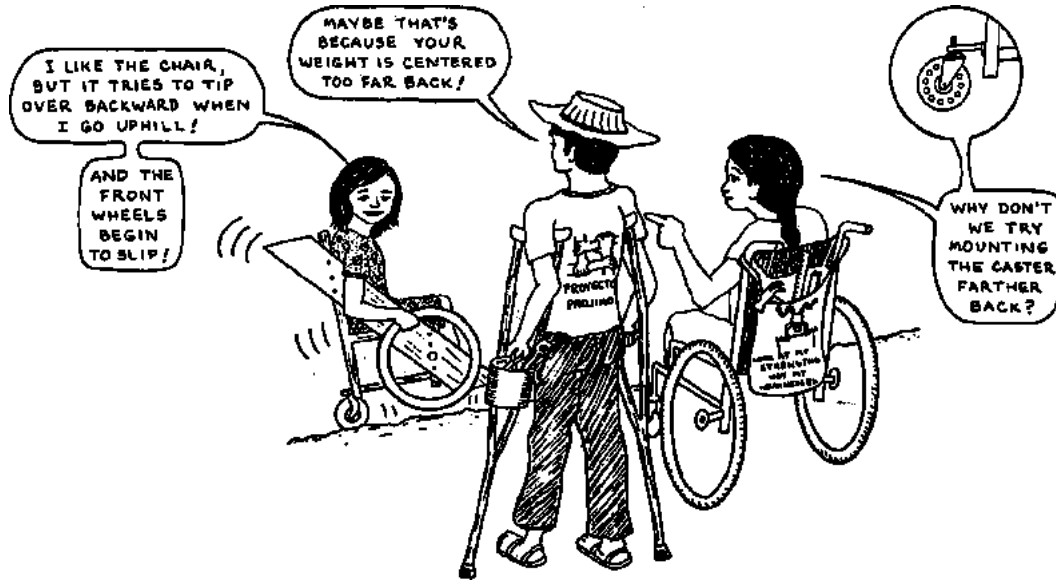

Figure

Some of the best design improvements in aids and equipment come from the ideas and suggestions of the children who try them out.

PRECAUTIONS IN PROVIDING A CHILD WITH AIDS, EQUIPMENT, AND PROCEDURES

To make sure aids and equipment really meet the child's needs, consider the following:

1. How necessary are the aids or equipment? Might it help the child more to learn to manage without them? For example:

Elena has arthritis. Her thighs have become too weak to support her body weight. You can fit her with braces and crutches. But watch out! These aids will not make her thighs stronger. They may even make them weaker, since she could then walk without having to use her thigh muscles.

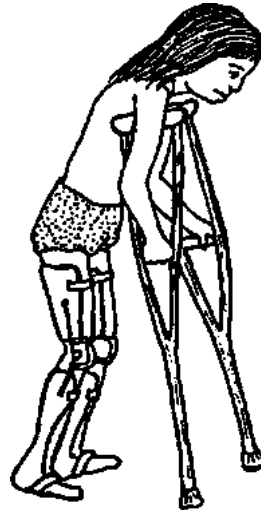

LESS APPROPRIATE

A better solution might be exercise to strengthen her thighs. For example, walking in water will make it easier for her legs to support her weight.



Also, using a cane instead of crutches helps her to use and strengthen her thigh muscles.

AVOID MAKING THE CHILD TOO DEPENDENT ON AIDS!

2. As any child grows and develops, his needs keep changing. Frequent *re-evaluation* is necessary to find out if an aid should be changed or is no longer needed. Ask the child what he wants. For example:

CP

Misha has been slow to develop balance for sitting. At first, straps helped him sit in a stable, upright position.



APPROPRIATE ONLY AT FIRST

But as he continues to develop, keeping him strapped in a chair may keep him from improving his balance more or from learning to sit without help.



APPROPRIATE LATER

Misha might be helped more by a seat that gives support to his legs and hips but lets him balance the top part of his body without help.

3. A simple, low-cost aid that is designed and made to meet the needs of a particular child often works better than an expensive commercial one. For example:

CP

Commercial wheelchairs are often too big for children, and hard to adapt to their positioning needs. Repairs are difficult and expensive; replacement parts are hard to get.



LESS APPROPRIATE

A simple wood or plywood chair can be easily made to fit the child's size and positioning needs. Repairs and replacements are easy because bicycle wheels and other standard parts are used.

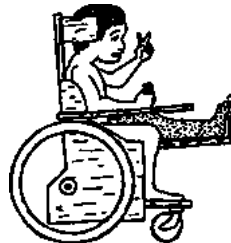

MORE APPROPRIATE

4. Consider the economic limitations of the family and community. Growing children will frequently need larger sizes of aids such as leg braces, artificial limbs, and special seating. Use either aids that are cheap enough to replace often, or that can be easily made bigger. For example:

Poor families sometimes spend as much as a year's earnings on an expensive, modern brace with knee and ankle hinges and special shoes.

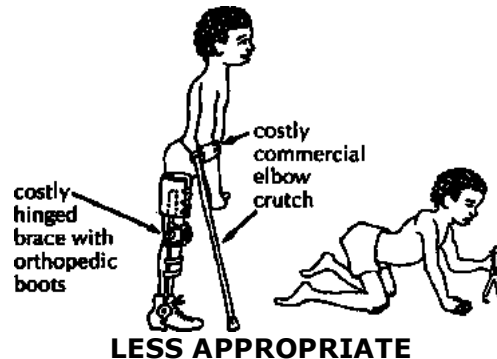

When the child outgrows the brace, or it breaks, the family cannot afford to repair or replace it - so the child goes back to crawling, develops *contractures* and may never walk again.

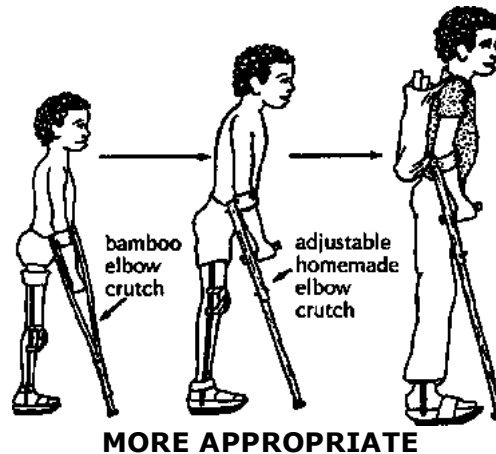

A cheap brace without hinges will not let the child bend his knee to sit. But the brace can be cheaply replaced, so the child is able to stay on his feet. Up to 20 low-cost braces can be made for the price of one expensive one.

5. Make use of the special opportunities in rural areas. Look for ways that a child can do her exercises as part of daily work and play with other people - not as a boring chore that keeps her separate and different. For example:

If a child needs a special aid to strengthen her weak arm

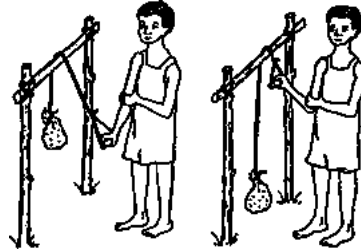

Figure

avoid making her do the exercises in a way that isolates her.



LESS APPROPRIATE

Instead find ways for her to do her exercises while taking part in activities with others

Another child can help lower the grinder



MORE APPROPRIATE

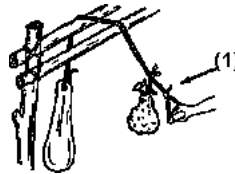

Figure

(1) If the grinder is too heavy to lift, you can put another weight here.

In places where people grind grain with a handmill this can also be used for exercises. So can grinding grain on a stone dish. A mill can be adjusted from easy to 'hard'.



Figure

6. Whenever a choice can be made, keep orthopedic aids as light and unnoticeable as possible. For example

Tina is from a village where most children wear sandals. A rehabilitation center in the city fitted her with a heavy metal brace and boots like this. She hated them and refused to leave the house with them on.



**Figure**

Six months later Tina's father took her to a village rehabilitation center where they fitted her with a lightweight plastic brace. She could wear it under stockings and still use her old sandals. She was happy to wear it anywhere

**Figure**

Note. In areas where children do not wear shoes and socks, a brace with a wood clog leaving most of the foot open to the air, may be preferred (and may be





Figure

7. Try to adapt aids and equipment to the local culture and way of life. An example of adaptation to the local situation is the 'Jaipur limb' (see also Chapter 67):

In India, villagers squat a lot. They cook and eat at ground level. A person with a standard artificial leg cannot squat because the leg does not bend enough in the knee and ankle. Also, the standard leg is not made to be used when barefoot, or in water.



LESS APPROPRIATE MORE APPROPRIATE
Figure

The "Jaipur limb" was designed for the needs of villagers in India. It has a knee with a joint that bends all the way. The foot piece is made mostly of rubber and is very flexible, allowing the person to squat. It is the color and shape (including toes) of a normal foot. It is waterproof, so that people can work in water or rice fields without harming it. The leg is low cost and quick to fit.

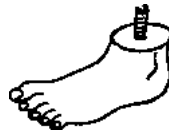

Figure

8. Make aids and equipment as attractive and enjoyable as possible. To test the

attractiveness of an aid, find out:

- Does the child take pleasure or pride in his aid?
- Do the parents like it?
- Do other children want to use it or play with it?

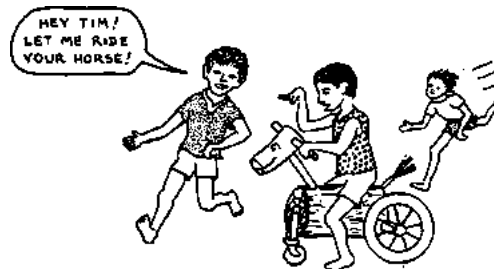
**Figure**

9. A common error is to provide children with more bracing than they need. Often a child will come to the rehabilitation center already fitted with big heavy braces that he never needed or no longer needs. They may actually slow him down. Always check to see what a child can do with and without his aids. Try smaller, lighter aids, or none at all. Above all, ask the child what he prefers.

**WHOOPEE!
ONLY 11 SECONDS!!**

WALK FROM
HERE TO THAT
FLOWER AS
FAST AS YOU CAN.

GOOD.
25 SECONDS.



Figure

NOW DO IT
AGAIN
WITHOUT
YOUR
BRACES.

EXCELLENT.
ONLY 17 SECONDS!

BUT YOUR FEET
BEND OVER SOME.
LET'S TRY WITH
SOME BELOW-KNEE
PLASTIC BRACES!



Figure

ONLY 11 SECONDS!!

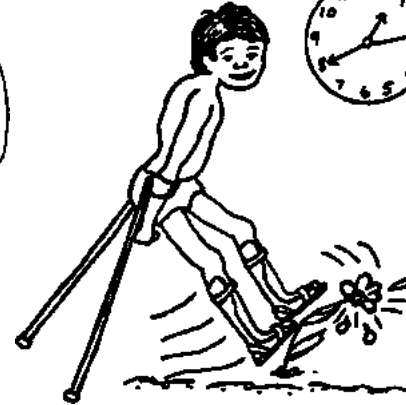

Figure

LESS APPROPRIATE

MORE APPROPRIATE

STILL MORE APPROPRIATE
(for this child)

EVALUATING WHICH DEFORMITIES SHOULD BE CORRECTED AND WHICH SHOULD NOT

PART 3 of this book, in addition to aids and equipment, also discusses methods for correcting joint contractures, which are discussed in Chapter 59. Just as you need to decide if a brace is appropriate, you need to decide whether correcting a contracture will actually help a child. Although many contractures increase difficulty for a child, some may actually help and should be left uncorrected. For example:

For this child it may be best NOT to correct the contracture.

In a child with polio, the weaker leg is often shorter.



Figure

The foot hangs down and often develops a tiptoe contracture (1) which, in effect, makes the leg longer.

If we correct the foot contracture, the leg will, in effect, become 'shorter'. This can cause tilting of the hips, a spinal curve, and more awkward walking.

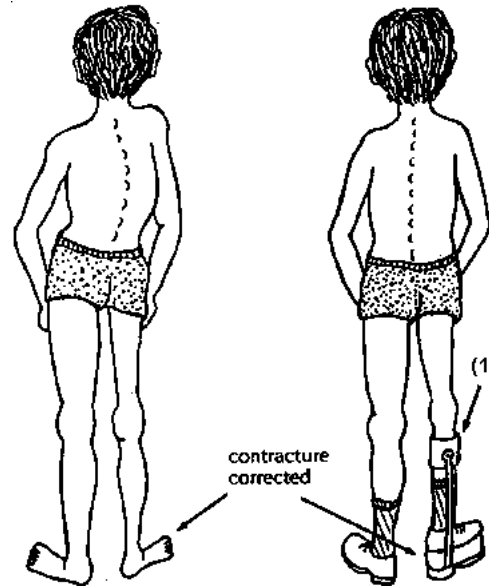

Figure

To correct the tilt and *spinal* curve, the child will need a lift on the shoe, and probably a brace too (1).

This usually makes walking more difficult, and the *disability* more noticeable, than before the contracture was corrected.

Other examples of contractures that are sometimes more beneficial than harmful are

finger contractures in persons with hand *paralysis* and tightness of back muscles in persons with *spinal cord* injury or muscular *dystrophy*.

CP

CAUTION: In children with *spastic* cerebral palsy, sometimes orthopedic surgeons perform operations to correct contractures or awkward positions, without completely evaluating the effects on the children. Often children find it harder to walk or function after the surgery. **Always seek the opinion of therapists and other orthopedists before deciding to have the operation.**



Figure

Before deciding to correct any contractures or deformities, try to be sure that the correction will help the child to do things better.

WHAT IS MORE IMPORTANT-APPEARANCE OR FUNCTION?

When a choice needs to be made between an aid that is more useful and one that is more attractive (or perhaps no aid at all), it is important to consider the cultural factors and to respect the wishes of the child and her parents. Here is another story.

A HELPING HAND FOR SRI

When Sri was 13 years old, one day she was helping her father at a small sugar-cane mill that was

pulled round and round by a mule. Her hand got caught in the gears of the mill and was crushed. It had to be cut off at the wrist.

The stump healed quickly, but Sri's spirit did not. It seemed as though it, too, had been crushed. She had been a happy girl. Now she just sat around. She did not help with housework, and refused to go outside. She kept her stump hidden in her clothing or behind her back

Sri's family worried about her. They took her to a specialist in the city who examined her and suggested an artificial limb. She gave Sri the choice between hooks, which would be useful, and an artificial hand, which looked more natural but would be less useful. The specialist encouraged her to choose the hooks, and explained how well she could learn to use them. But Sri picked the hand.



Figure

The hand was very expensive, but it looked almost real, and the family agreed. Her father had to sell his mule to pay for it, and was in debt for more than a year

As time went by, however Sri never really used her new hand. She tried it on a few times but it seemed cold and dead. One day when her mother took her to the market wearing the hand, Sri thought everyone was looking at her. Two little boys, who had been her friends, pointed at the hand and laughed. She never wore it again.

One day a village health worker visited Sri's home. She saw that everyone was busy working and doing things except Sri, who sat quietly in the corner.

After talking with her family, the health worker suggested that they make an effort to treat Sri just like the other children. Encourage her to help with work, and to take part in all your activities, she said. Don't pretend that Sri's hand isn't missing. Just accept her as she is. Let her know that you love her and need her help as much as before"

So instead of feeling sorry for Sri, or letting her just sit and feel sorry for herself her family began to treat her as they had before the accident. They asked her to help with the housework, prepare the meals, and care for the baby. At first Sri was unwilling and found everything difficult. But soon she learned how to do many things by using her good hand and her stump. She began to gain new confidence in herself and in time started going to the market alone. At first, people took notice of her missing hand, or whispered, "Oh poor thing!" But when they saw how well she did things, they soon stopped feeling sorry for her and began to treat her like any other person



It is important that the family not let the disabled person be separated from daily work and activities



Instead, look for ways to let the disabled person help as best she can

When trying to decide about an aid, we need to seek the balance between usefulness and attractiveness that helps the child fit in best with his or her family and community.

Rehabilitation experts often place great importance on usefulness, or 'function'. But acceptance in the community is also very important. In some places it may be more important. So, before trying to convince a child like Sri to accept an aid that will make her deformity more noticeable, we must consider how this could affect her. In some communities, people will soon accept both the child and her aid. But in some societies, people have beliefs or deep fears about a person whose body is 'incomplete'. In other societies, amputation of a hand has traditionally been the punishment, and sign of a thief. Or a girl who is seen as defective may not be likely to find a husband. So, it may be socially very important for her to have an aid that looks real or is less noticeable, even if it does not function. (If the family can afford them, sometimes the best solution is 2 artificial limbs - hooks for home use or work, and a 'hand' for 'dressing up' and going out.)

APPEARANCE CAN BE IMPORTANT

For example, one of the most useful solutions to amputations of both hands is an operation which uses the two bones of the lower arm to create 'pinchers'. The operation is fairly simple for an orthopedic surgeon, and once completed no aids are needed for grasping and handling a wide variety of things; The biggest advantage **is that the person can feel what he handles**. But few people choose this alternative because, they say, it looks so strange.



Figure

It is, of course, unfortunate that a child feels ashamed or thinks she has to hide her disability. We must work for greater understanding. But people do not change their attitudes quickly. Often the child and her parents have good reasons for their fears, and we must learn to accept them. However, we must also help the child, her family, and the community to become more accepting of the child's disability and to provide as many opportunities for the child as possible.

We need to help the child find courage. A child with a new disability will often be afraid to go out into the community, or back to school. And other persons or children may at first take notice and 'feel sorry' for her-or even tease her. But if she can be helped through this first difficult period, usually other people and children will soon get used to her 'difference' and accept both it and her. As more disabled persons find the courage to go out into the community, it will be easier for those who follow, because people will become more open and accepting.

In the story of Sri, the rehabilitation specialist tried to solve her problem by giving her an

artificial limb. Her family spent a lot of money on it. But the new 'hand' did not solve her problem. She never really accepted or used it. Her problem, which was partly emotional, was finally solved by the whole family helping her to join them again in daily activities, and to gain new confidence in herself.

This is very important. Too often we try to find technical answers to problems that are mostly personal, social, or emotional. So we turn to special aids and equipment. Sometimes these are needed. But sometimes they are unnecessary, too costly, or make life more difficult for the child (even though they may be of some help physically). So...

Before deciding if a child needs special aids, braces, surgery, or equipment, and what kind, carefully consider the needs of the whole child within her family and community.

Chapter 57: A 'Shop for Making Aids' Run by Disabled Villagers

In PART 2 of this book we talked about the value of village-based rehabilitation centers run by local disabled village workers.

One important feature of such a center is a simple but adequately equipped shop for making basic *orthopedic* equipment and *rehabilitation* aids at low cost. The shop also gives disabled persons a chance to learn useful skills, to earn some money, and to be good examples for other disabled children and their families.

There is no formula for how big the shop should be or what it should include. Often it is best to start small but to leave room for growth.



Disabled villagers at work in shop - PROJIMO, Mexico.

A 'rehab shop' might include areas and equipment for any or all of the following activities:

- **plaster casting for correcting contractures and club feet**
- **brace (caliper) making using metal, plastic, or both**
- **woodworking - for making crutches, walkers, lying and standing frames, special seating, wooden wheelchairs**
- **welding and metalwork for making and repairing wheelchairs and other metal aids**
- **leatherwork for making brace straps, *adaptations* for shoes and sandals, and knee pieces**
- **sewing (with machine if possible) for wheelchair seats, straps, special clothes, and other articles**
- **artificial limb making - for making simple bamboo or leather limbs and perhaps**

more complex ones of wood, aluminum, or resin

- **game and toy making (or this can be done in a separate 'children's workshop'. See Chapter 49).**

Income-producing activities as a part of the shop function

The skills and tools for welding, woodworking, sewing, and leatherworking can also be used to make things other than those needed for rehabilitation. The village shop and its workers can make things that can be sold to help pay for program costs.

For example, disabled workers in the shop of PROJIMO in Mexico make metal framed chairs with woven plastic seats, sandals with auto tire soles, and silk-screened goods such as bags, T-shirts, and aprons. The shop also provides welding or repair services for plows, bicycles, machinery, shoes, and many other things. Selling these things and asking small charges for repair services brings in some money to the program, helping it toward self-sufficiency. It also provides training and work experience for disabled workers who may later choose to work independently.

However, caution must be taken not to try to do too many things in one workshop-especially if space is limited. It can easily become too disorganized.



Villagers and visiting students building the PROJIMO workshop.



The completed workshop - at the edge of the playground.

The building

You may have to start with whatever space or building you can find. If you have enough funding or community cooperation (or both) you may be able to build a shop. However, it is often best to start in some old rented or borrowed building, and not build your own shop until you have experience and a better idea of just what you need.

Three things are important:

1. Try to put the shop close enough to the rest of the rehabilitation center for convenience, yet far enough away so that shop noise does not disturb discussions and therapy with children and their families.
2. In hot climates especially make sure the shop is well ventilated (allows air movement). A roof with one or more walls that are open, except for bars or fencing, works well.
3. Be sure there is plenty of storage space. This is especially important if old braces, wheelchairs, bicycles, and other used equipment are collected for used parts, to save money

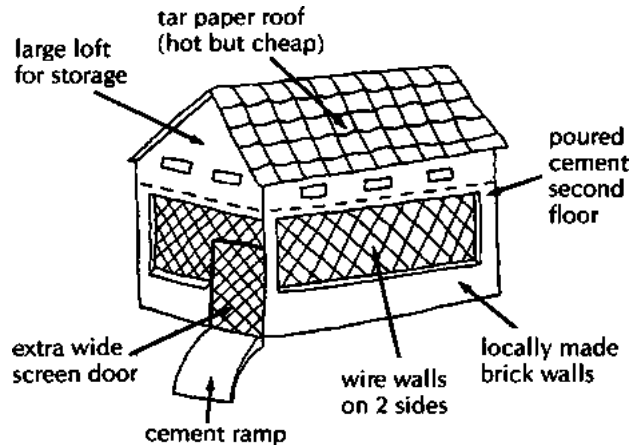

Figure

The PROJIMO workshop first opened on the back porch of an old house. A year later a new shop was designed and built with community participation, and some outside funding. It is 8 × 12 meters. Two walls are screened, on the sides the rain is least likely to blow in. A large loft provides storage space and helps to keep the work area below cooler. The new shop is already too small!

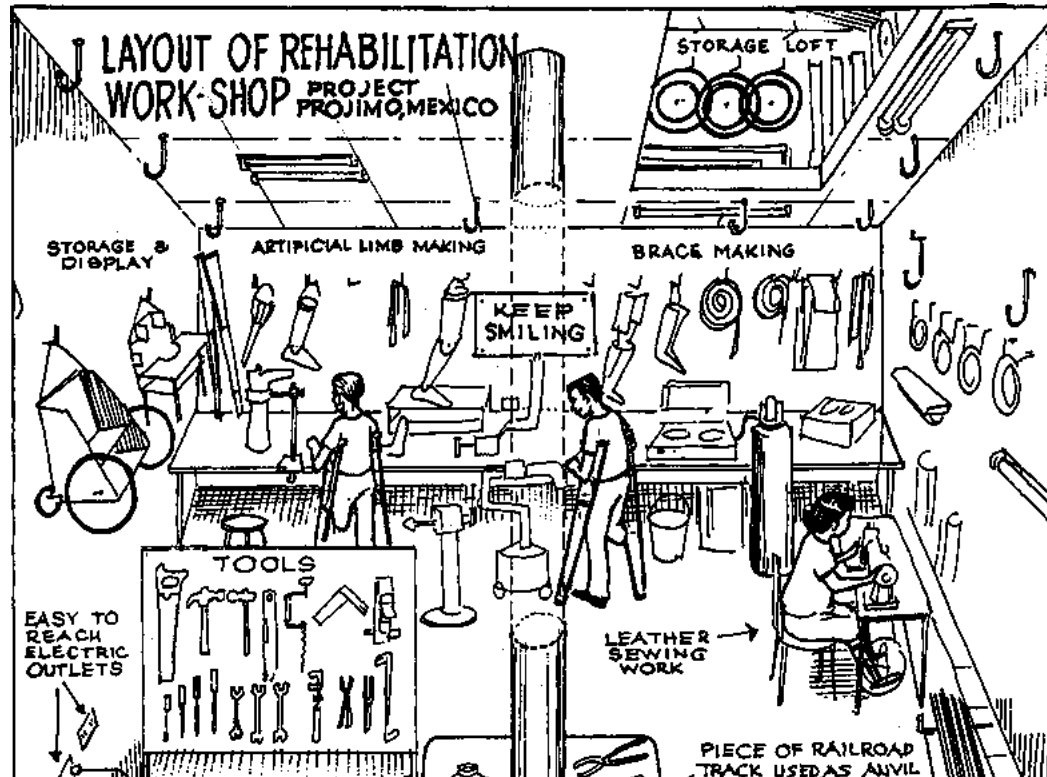

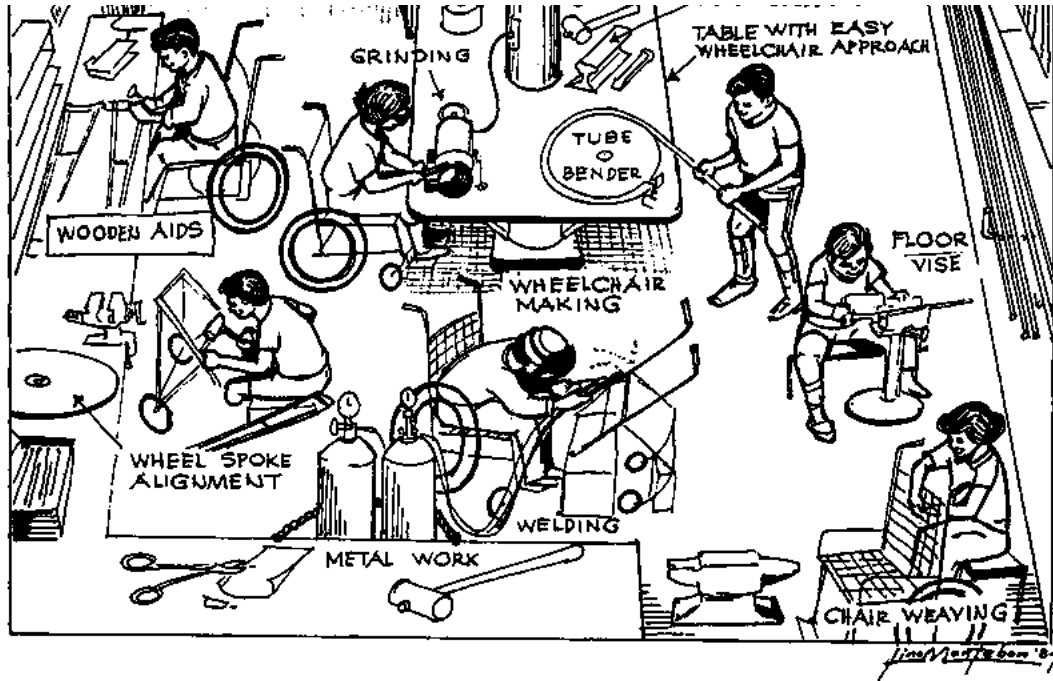

Figure

Arrangement of work space

Each program needs to plan its own use of space. However, a few things are important if persons in wheelchairs will be workers:

- Enough space should be allowed everywhere for 2 wheelchairs to pass each other.

- **At least some of the workbenches should be low enough to work at from a wheelchair or stool. Build them so that wheelchairs can get close to or under them with as few obstacles as possible**
- **Tools and supplies should be stored within easy reach of workers in wheelchairs. Also, switches and power outlets.**

The drawing shows how the workshop of PROJIMO is arranged. We include it as an example, not as a model.



Figure

Photo: Richard Parker, PROJIMO

Tools and Equipment

What is needed will depend on what activities the shop includes, how simple or complex is the technology used for each activity, and whether or not electric power and tools are available. Nearly all aids can be made of local materials with hand tools, and without

electricity. Even wheelchairs, if made of wood, can be built with few tools or equipment. The small amount of welding required for axles could perhaps be done by the nearest welding or auto repair shop. However, having a few time - and effort-saving tools can make work easier, faster, and more enjoyable: a sewing machine, a grinding wheel (whether hand crank or electric), and a gas or electric stove (to heat plastic for braces). Welding equipment or a blacksmith's forge and bellows makes possible the production of many things.

Basic tools and equipment for the shop will be discussed in more detail in this section of the book, PART 3, the chapters of which describe making different kinds of aids.

One very expensive but important piece of equipment is an **electric cast cutter**. It is an extremely useful tool for removing plaster casts and for cutting molded plastic braces from plaster forms. It is also a relatively safe tool, because the blade vibrates, but does not turn, so it cuts I hard things like plaster more easily than soft things like skin and flesh.



Figure

Training for shop skills

Possible ways for learning different shop skills were discussed in Chapter 54. Here we will only repeat that one of the best ways to learn shop skills is through 'apprenticeship', or learning-by-doing under the guidance of someone with more experience. Perhaps local craftspersons, such as carpenters, welders, and shoemakers would be willing to help teach members of the team. If the team has one or two persons with basic crafts experience, they can teach the others. For brace and limb making, it may help if one of the

rehabilitation team has a chance to visit and learn in an orthotics and *prosthetics* shop. Or perhaps a skilled brace or limb maker can come for a few weeks to help set up shop, obtain basic materials, and teach the local team.

With an active, learning-by-doing approach, together with hard work to meet daily needs, team members can quickly become relatively skillful. On the other hand, if the team is made up, at least in part, of young disabled persons who have never worked before or cooperated as members of a team, both learning and work may at first progress more slowly.

Management and job assignment

How work is organized in the shop, and who organizes it, are decisions that need to be carefully discussed and decided by the group. Some programs have someone acting as 'boss' or 'foreman' who assigns each person a job. This may be more efficient. But programs that are 'people centered' prefer a more cooperative approach, where the whole group is involved in making key decisions. With such an approach, a coordinator may be chosen (or different coordinators can be chosen for different responsibilities). The coordinator does not give orders, but rather takes orders from the group. This approach is usually less efficient and more confusing. However, it is more enjoyable. Workers tend to take more interest, responsibility, initiative (and time off) than they do under a boss.

Also, the team needs to decide about how work is divided, and who does what jobs. Some workshops employing disabled persons use an 'assembly line' approach. Each person does a simple, repetitive job, such as cutting out one piece of tubing time after time or putting spokes into wheels. This approach requires relatively little training for each worker. Mentally retarded workers who learn by repeating something over and over again often do well working this way.

However, most people work better when they are able to make something from beginning

to end. Then they can share the satisfaction of a child and her family when a wheelchair or brace or toy they made looks nice and works well. In PROJIMO, whenever possible, workers (individually or in pairs) are responsible for the complete production of an aid. They start by helping to evaluate the child's needs and end by seeing how well the finished aid meets those needs. This way, each worker can see the personal value of each aid that he or she makes. This approach may be less efficient, but it is more satisfying. Thus the team watches the results rather than the clock, and works first for the people, not the money. This personalized approach is very important to a program designed to serve those in greatest need.



PART 3 of this book provides information on two main areas: (1) non-surgical orthopedic procedures (straightening contractures and club feet with casts), and (2) the production of low-cost rehabilitation aids. All of these things can be done in a village-based workshop such as the one just described. However, many of the aids can also easily be made at home by the family of the child.

To encourage family participation in making aids, and later repairing them, mothers, fathers, sisters, or brothers can be invited to the shop to help build the aid. Or disabled children can help make their own aids. Some of the best workers in the PROJIMO workshop today began as young people who helped make their own crutches or wheelchairs-and then began to help make aids for others.

The ideal is that everyone does what they can to help and learn from each other: one big, human family working together and enjoying each other.



In Peshawar, Pakistan, the Community Rehabilitation Development Program makes leg braces from plastic bus windows. Here a worker heats the plastic over an outdoor mud stove.



When the plastic is hot and soft, workers drape it over the plaster leg mold. Then they wrap it tightly with strips of rubber inner tube until it hardens.

Chapter 58: Braces (Calipers)

Braces are aids that help hold legs or other parts of the body in useful positions. They

usually serve one or both of 2 purposes:

1. To provide support or firmness to a weak joint (or joints). For example, this child had polio:



His leg is too weak to support his weight without help.



This brace keeps his knee from bending forward

2. To help prevent or correct deformity or *contracture*. For example, this child had a club foot:



He was born with a club foot



His club foot was corrected with a cast



After, correction, his foot is kept in a good position with a brace

CAUTION: The need for braces should be carefully evaluated. Braces should be used only if they will help the child move better and become more independent. Too much bracing may actually weaken *muscles* and cause greater *disability*. As a general rule, **try to use as little and as light bracing as possible to help the child function better.** (See Chapter 56)

Different braces for different needs

The main lower-limb brace types are:

Foot brace



usually made of molded plastic



for deformities in the foot (not ankle) such as severe flat foot

Below-knee braces (ankle brace)



for weakness or deformities in the lower leg, ankle and foot

Above-knee brace (long-leg brace)

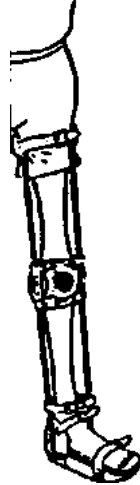

for weakness in the upper leg and knee - possibly also ankle and foot

Above-knee brace with a hip-band

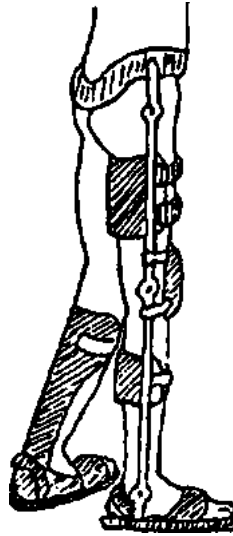

for severe weakness in hips and legs

Less commonly used types include:

Leg-separating braces



for dislocated hips or damaged head of thigh bone

***Foot-positioning* night brace**



for holding the feet, legs, and hips at a set angle when they tend to turn in

Body brace or corset



for curve of the spine

Body brace with leg braces



for body and back weakness together with hip and leg weakness

Different materials and ways to make braces

As we discussed in Chapter 56, an ideal brace should:

- **serve its purpose well (help the child walk or function better)**
- **be comfortable**
- **be lightweight yet strong**
- **be as attractive as possible**
- **be easy to put on and take off**
- **do no harm**
- **be low cost**
- **be easy and quick to make with local tools and limited skills**
- **use local or easily available materials**
- **be easy to repair and adjust as the child grows or develops**
- **be long lasting**

Unfortunately, no brace will meet all these requirements. As much as possible, try to put the child's needs first.

In this chapter we give ideas for making different braces using various materials. When deciding how to make a brace, carefully evaluate both the child's needs and the available resources (see Chapter 56).

Sometimes it is wise to start with a simple low-cost temporary brace or splint to see how well it works and what the problems are.

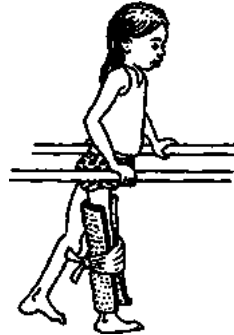

Figure

Keep old and outgrown braces for testing on new children before final braces are made.

But take care not to discourage the child by making him use braces that do not fit him well.

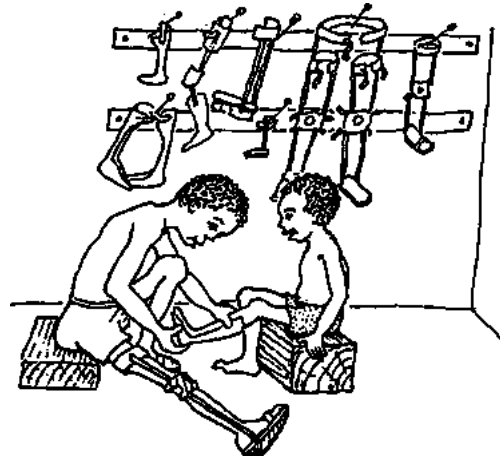

Figure

Examples of very simple, low-cost braces and splints:

A temporary leg splint of cardboard, folded paper, or the thick curved stem of a dried banana leaf, or palm leaf.

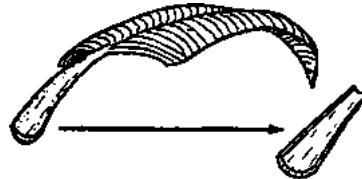

Figure

Aluminum tube finger splint

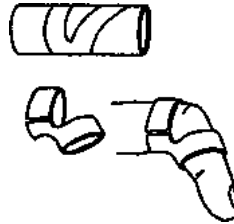

Figure

Mango seed finger splint

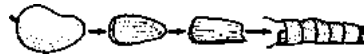

Figure

Remove the woody coat of a mango seed, and wrap the coat firmly onto the finger. It will dry into a firm splint. To change its shape, first soak it in water.

Bamboo ankle splint

A piece of seasoned bamboo can be heated and bent.

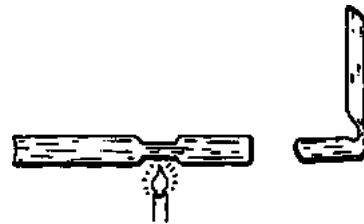

Figure

Plastic cup ankle braces for night or temporary use on a small child.

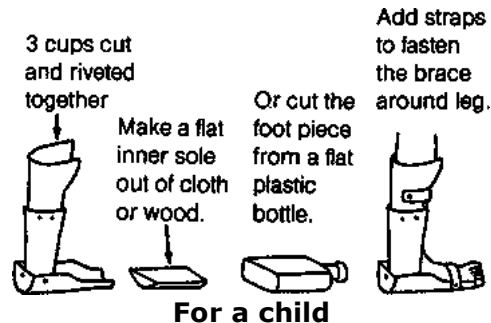
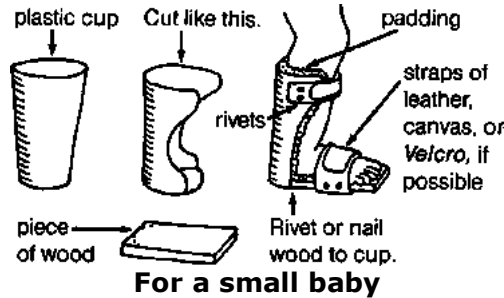

Metal or plastic braces

Modern, high-quality braces are usually made out of metal or molded plastic.

The best metal is a mix or 'alloy' of aluminum and steel which is both light and strong. However, this is very costly and often hard to get. Pure aluminum is very light, but breaks easily, especially when you try to bend it. Steel is cheaper and easier to bend and weld,

but is much heavier.

The best plastic for braces is probably polypropylene, which is strong, light, and fairly easy to shape when hot.

Pre-formed metal parts for making these braces are sold at *orthopedic* supply stores. Unfortunately, they are usually much too expensive for a community program. However, sometimes you can get large orthopedic centers to donate old braces, from which locking knee joints and other pieces can be used to build high-quality metal or plastic braces. Also, many broken or outgrown braces are lying in the corners of thousands of homes. A campaign to get families to donate these can greatly reduce the costs of making high-quality braces.



plastic below-knee brace

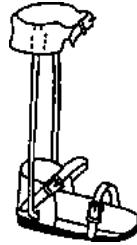

metal below-knee brace with wood clog

Low-cost metal or plastic braces can be made in a village shop. They can be made simply, with or without joints. Since children grow quickly, they often need a larger brace every 3 to 6 months. Therefore, keeping cost low and work simple is essential. (See Chapter 56.)

Metal and plastic braces each have advantages and disadvantages.

In Mexico, we have found that for most children who need below-knee braces, plastic works best. And the children (and parents) like it more.

However, a child with a lot of muscle tightness (due to *spasticity* or contractures) which pulls his foot a lot to one side, like this, may need a metal brace with an ankle strap. After the brace is on, the strap is tightened to pull the foot into a better position.



Figure

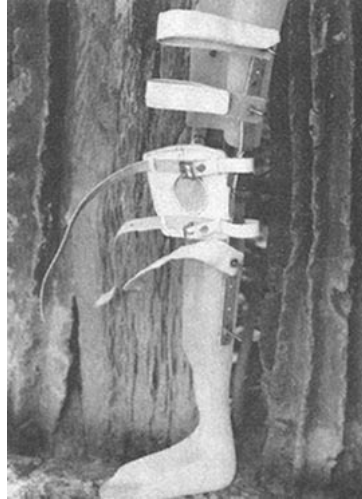

Above-knee braces can be made using a combination of plastic and metal.

Whenever possible, equip your village shop to make both plastic and metal braces. That way, you can make what seems most appropriate for each child.

FITTING PLASTIC OR METAL BRACES

***IMPORTANT:* Correct measurements are essential for a good fit.**

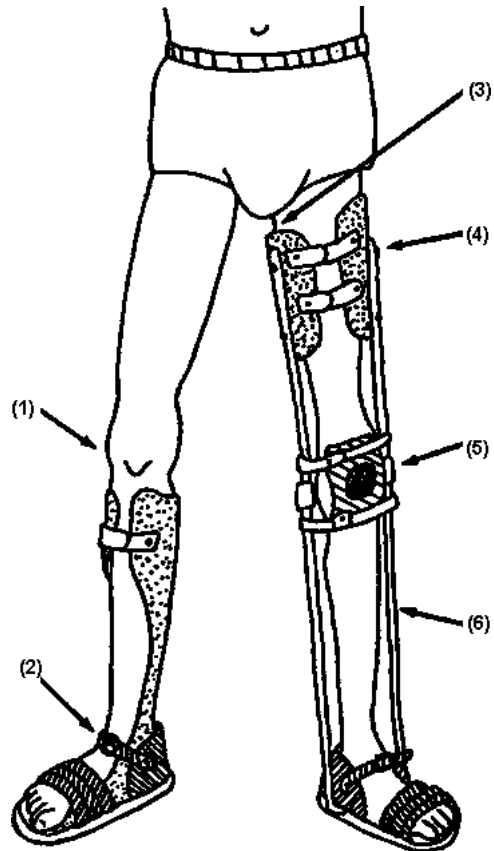

Figure

(1) Below-knee brace should reach almost to knee, yet allow knee to bend all the way.

- (2) Brace or clog should grip heel and ankle closely.
- (3) Above-knee brace should reach to about 2 cm, below groin.
- (4) Upper part of leather or plastic of brace should fit around the thigh closely.
- (5) Knee hinge (if used) should be at the middle of the knee, both in height and from front to back.
- (6) Side pieces should be close to knee but not touch or rub the child when he walks.

If the leg is very weak or joints are damaged, the top of the brace can have a lip on which the butt rests, to bear part of the body weight. (For design, see "Artificial Legs")

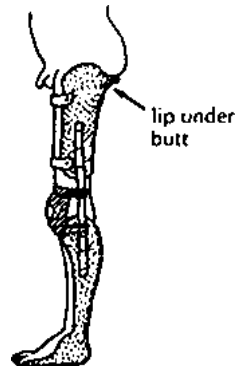

Figure

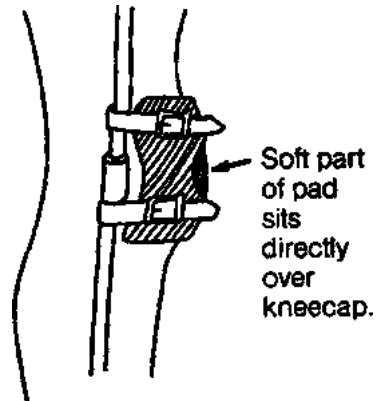

KNEE PIECE

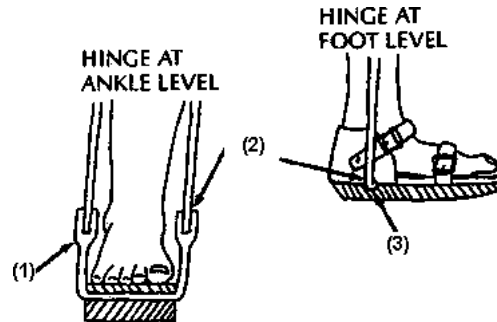

Figure

(1) Ankle hinges, if used, should be at the level of the bony lumps of the ankle.

(2) *Note:* A brace with a hinge at **ankle level** is better than one with a hinge at **foot level** because it bends at the same height as the ankle joint. (However, a metal brace with ankle

hinge is more difficult to make.)

(3) Side rod should attach at a point directly below the midline of leg.

METAL BRACES

The advantages of simple metal braces are that they are quick, easy, and cheap to make. They often last longer, and, if used with sandals or clogs, in hot weather they are cooler than plastic. However, they also have disadvantages: because a shoe, sandal, or wood 'clog' must be built or attached to the brace, there is additional work and cost. Also, they are heavy, clumsy, and more noticeable. In hot or wet weather, leather or cloth, or even the metal starts to rot. Shoes or boots which the child cannot change, even when they get wet, begin to stink.

METAL ROD BRACES* using 're-bar' (reinforcing rod for use in cement building construction)

*** Much of the information on metal braces, on this and the following pages, is taken or adapted from *Poliomyelitis* by Huckstep, and *Simple Orthopaedic Aids* by Chris Dartnell.**

For a brace shorter than 50 cm. (20 inches) you can use rod that is 5 mm. thick. For a longer brace, the rod should be thicker - up to 8 mm.

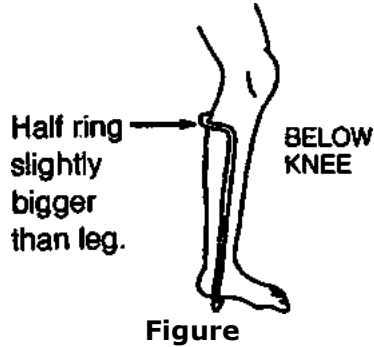
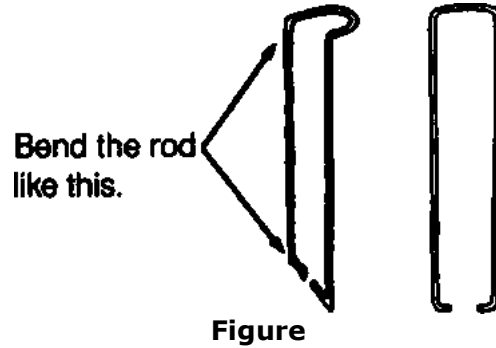

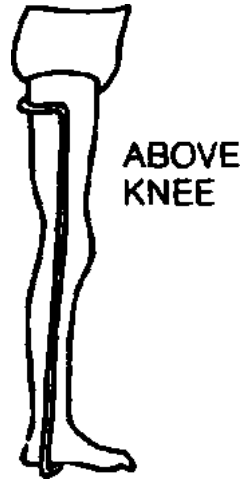

Figure

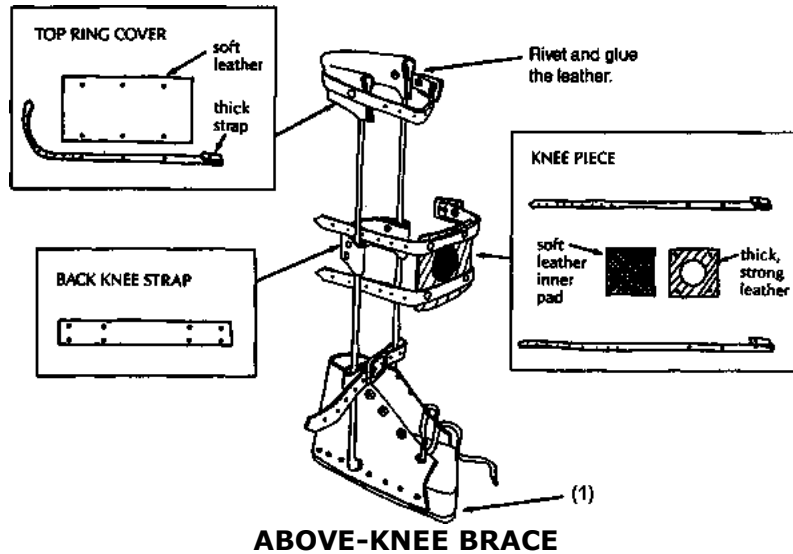

(1) Note: These flat-bottomed soles make walking more difficult.

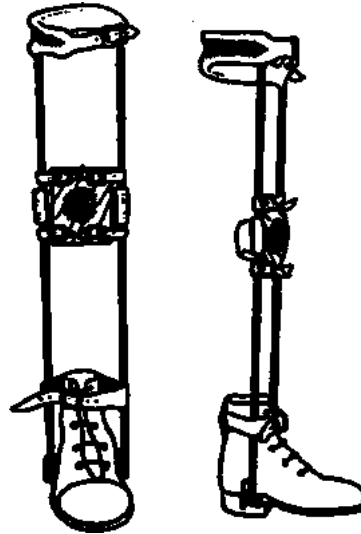

ABOVE-KNEE BRACES

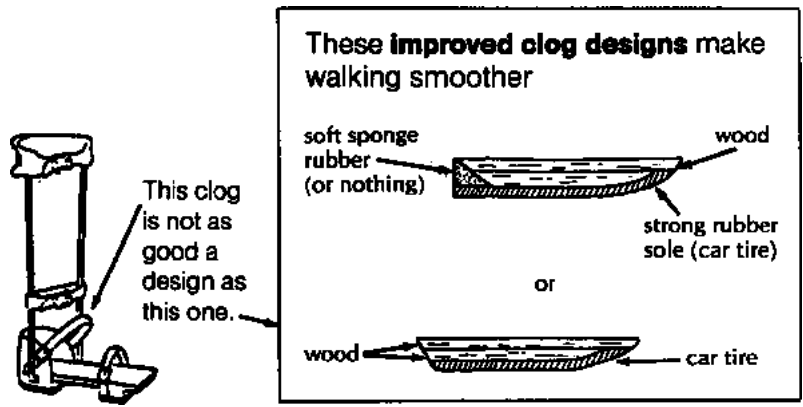

BELOW-KNEE BRACE

SHOES AND CLOGS FOR METAL BRACES

High-top leather shoes often work best, especially in communities where children usually wear shoes.



Figure

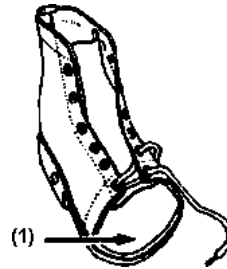

Figure

Shoes are easier to put on when the whole top can open wide. It may help to cut off the front part of the shoe (1).

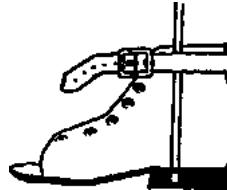

Figure

Leaving the toes open to “breathe” is also important if a child is not likely to wear (or wash) stockings.

For adding thicker soles and making other changes, it helps to buy shoes with soles that are sewed on. (Today, many shoes have plastic or rubber soles that are glued on or molded with the shoe. These are much harder to work with.)

Unfortunately, leather shoes are costly. Also, they may not last long in rain and mud. So, you may want to make simple, low-cost wooden-soled shoes, or clogs. This design is from

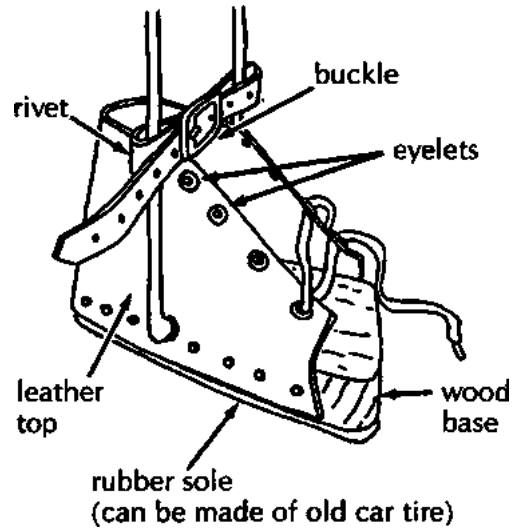
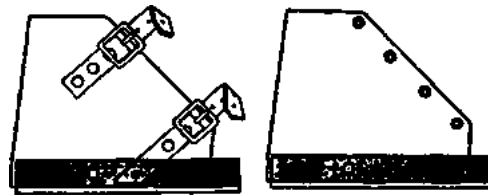
Simple Orthopaedic Aids.**Figure**

strap clog

face-up clog

Figure

1. Draw around the foot on a piece of wood about 2 1/2 cm. thick. Be sure to use a wood that is not likely to split.



Figure

2. Leave extra space as shown (to allow for child's growth). Cut out the piece of wood.



Figure

3. Carefully draw this shape on a piece of paper, using the length of the clog as a guide. Then cut it out. Drill hole for brace, 1/3 of the way up clog.

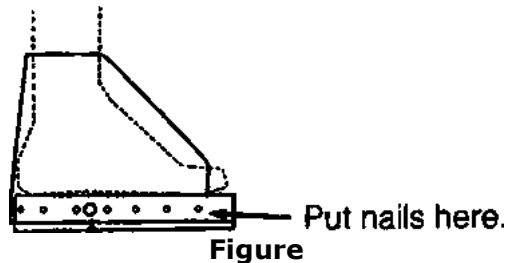

Figure

4. Now draw both sides of the leather top. Between the 2 sides add the width of the clog.

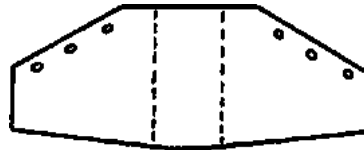

Figure

In communities where most children go barefoot, a disabled child may prefer more open clogs. This design is adapted from Huckstep's *Poliomyelitis*, and the 'Jaipur Sandal'.

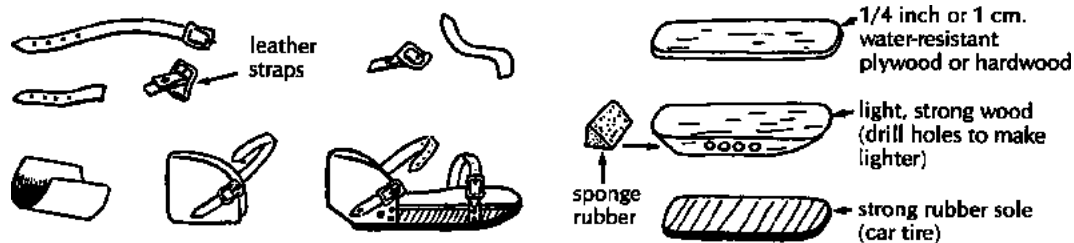

Figure

Note: These open clogs are hard to fit on deformed feet or feet with tiptoe contractures. In such cases, high-top clogs or boots work better. Or use plastic braces molded to fit the foot.

HOW TO CONTROL UP AND DOWN MOVEMENT OF FOOT

CONTROLLING FOOTDROP AND TIPTOE DEFORMITIES

A child with 'footdrop' or a floppy foot that hangs down so that she has to lift her leg high with each step,

needs a brace that holds the foot up. Use a plastic brace,

or a metal brace with a backstop that lets the foot bend up, but' not down



Figure



Figure

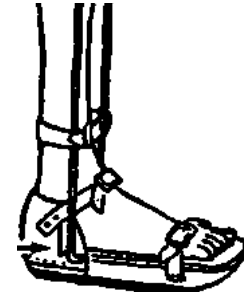

Figure

Making a backstop

Cut a thin plate of steel



Figure

Bend it



Figure

Screw it to the heel piece

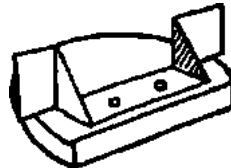

Figure

Assemble clog. Put in a lining to protect foot.



Figure

Note: A child with spasticity whose foot pushes down hard may need a longer plate to keep it from working loose

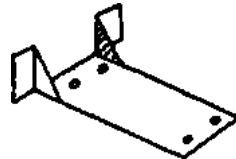

Figure

Toe-raising spring

Another way to help prevent footdrop is with a toe-raising spring

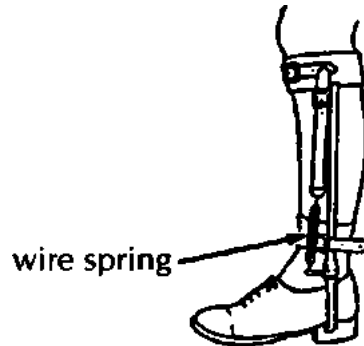

This is a more complicated design

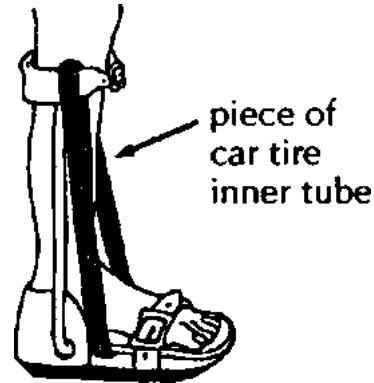

This is a simpler design

CONTROLLING FOOT-RISE AND UNWANTED KNEE-BEND

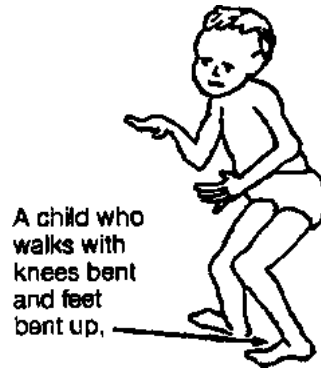

Figure

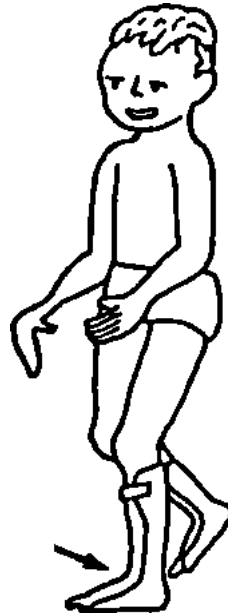

Figure

may (or may not) be helped by a trace that prevents the foot from bending up as much. If possible, use a stiff plastic brace (1).

Or use a metal brace with a stop placed in front of the upright bars

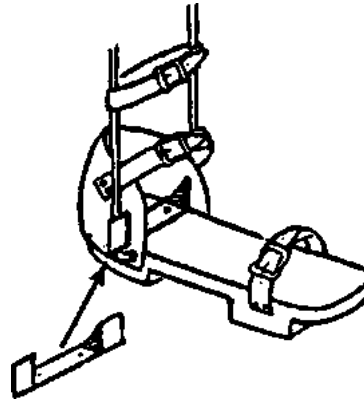

Figure

A strong stop with a long plate will be less likely to work loose or damage the clog.

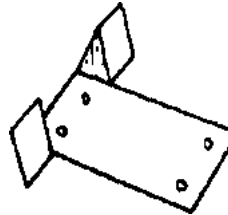

Figure

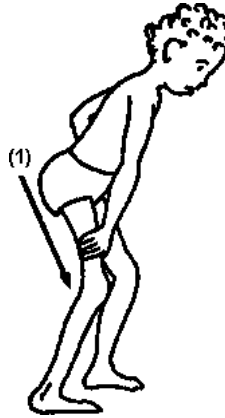

Figure

A child whose weak leg bends at the knee when he tries to put weight on it (1).

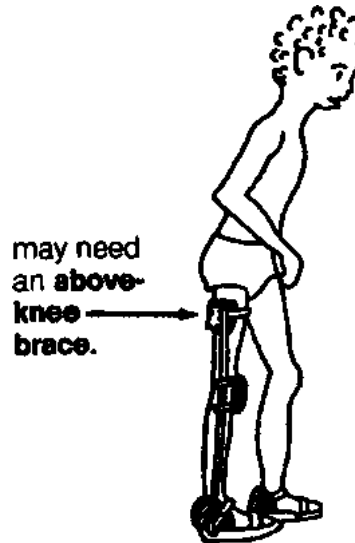

Figure

But sometimes a below-knee brace that stops the foot from bending up will help push the knee back enough so that the child can support his weight on it.

The brace can be of stiff plastic, or metal with stops to prevent foot-rise



Figure

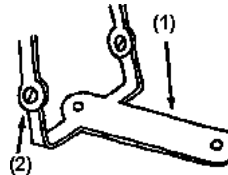

Figure

If a brace with an ankle joint is used to prevent the ankle from bending up, the base piece will need a long, strong, forward plate (1).

The joint can be adjusted to allow only the desired range of motion (2).

KNEE HINGES

Braces with locking knee hinges permit the child to bend her knees for sitting or squatting.

Non-bending knees are satisfactory for most children. The child can sit with her leg straight.

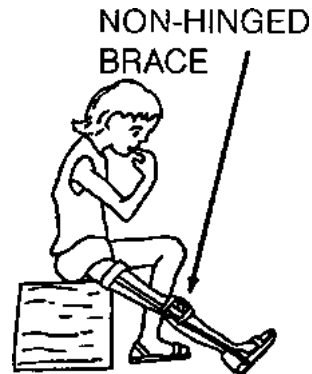

Figure

However, in some communities, a child may 'fit in' better if he can squat.

However, hinged braces have disadvantages: they are more costly and take longer to make. A child outgrows them quickly-unless they are adjustable. So use your judgment.

The knee hinge locks for walking and unlocks for sitting or squatting.



Figure

Hinges on a round-rod brace

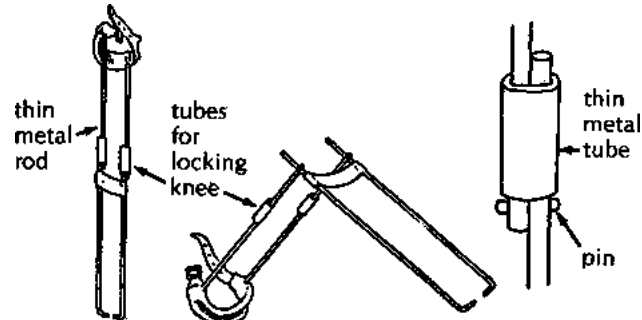

Child pulls up tubes to bend knee.

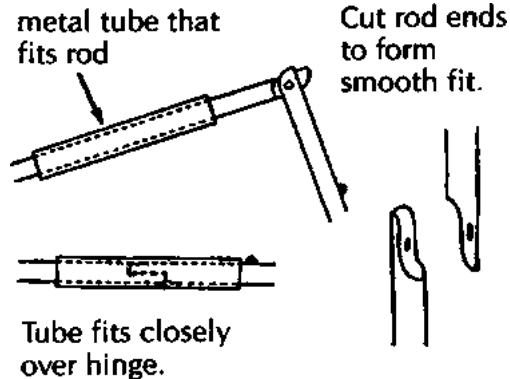

A BETTER HINGE

A simpler hinge such as the ones above for a round rod can also be used on a flat rod.

A hinge for flat metal bar

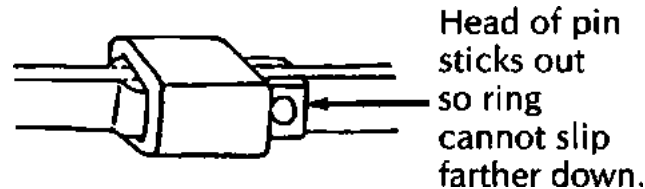
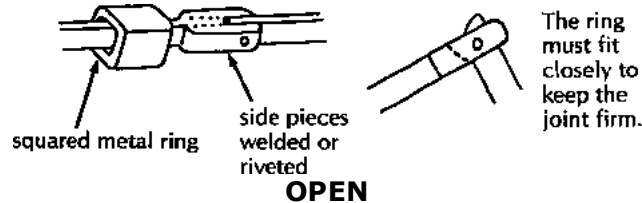

LOCKED**BRACES THAT FOLLOW THE SHAPE OF THE LEG**

Flat metal bar can be bent to fit the shape of the leg more closely. This is not always necessary but if done well the brace will fit better - especially when the bar is used with molded plastic.

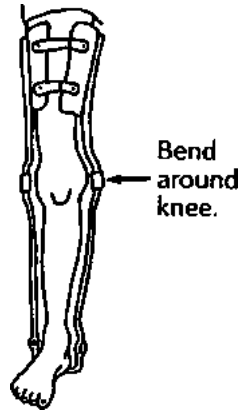

Figure

ADJUSTABLE BRACES

As the child grows, a brace made like this can be lengthened. Teach family members how to do this.

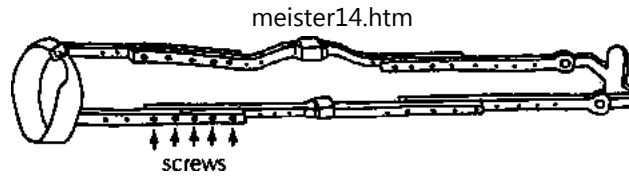

Figure

HIP BANDS

Braces with a hip band may be needed for the child:

whose leg (or legs) is so weak at the hip that it flops or turns far out to one side,

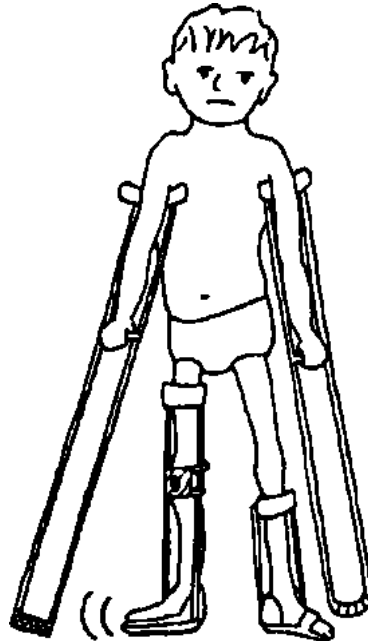

WITHOUT HIP BAND

or whose legs tend to twist too much inward (or outward).

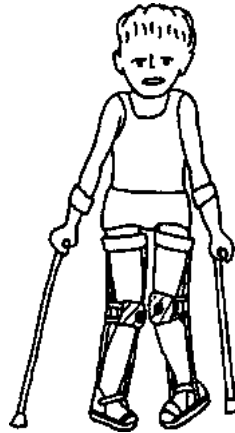

WITHOUT HIP BAND

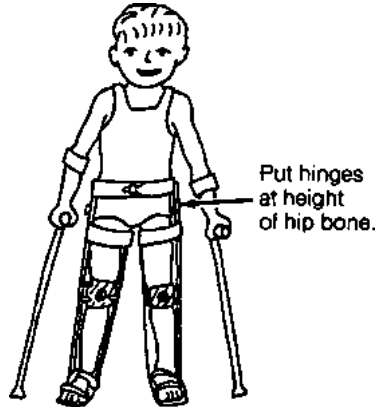

Put hinges
at height
of hip bone.

WITH HIP BAND

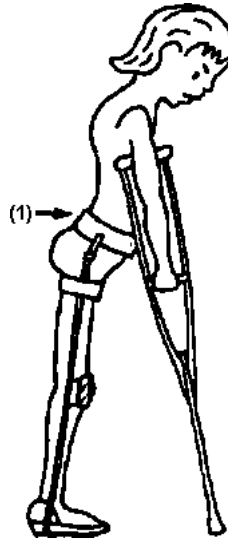

Figure

A common problem with hip bands is that the low back bends forward (1) and the butt sticks out. This can cause back problems, and hip contractures.

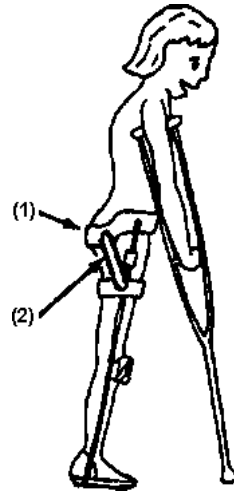

Figure

A hip band that dips down in back down to push in the butt (1) helps prevent this problem. If necessary, add an elastic strap here (2).

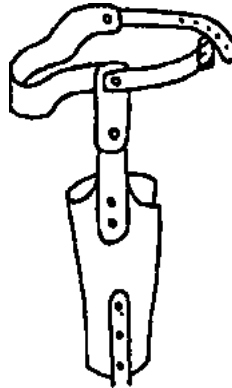

The back of the hip band can be made of thin metal lined with leather, or of strong plastic.

On plastic braces the side bars and hinges can also be made of thick, strong plastic. This adds some flexibility, which will be better for some children but not provide enough support for others.

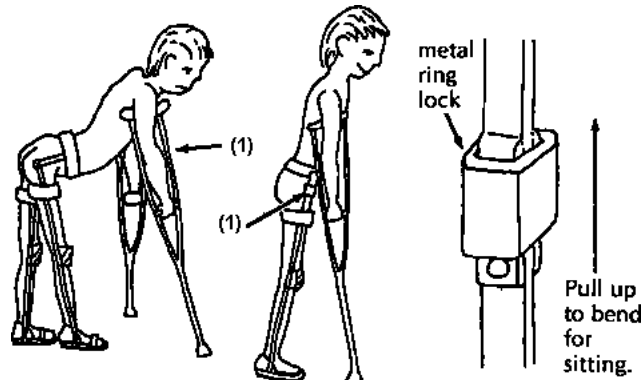

Figure

A child who tends to flop forward at the hips (1), may need a hip band with a locking hinge.

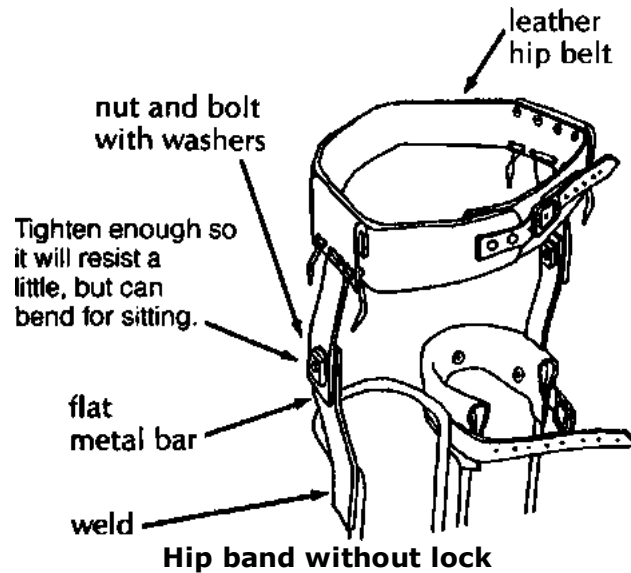

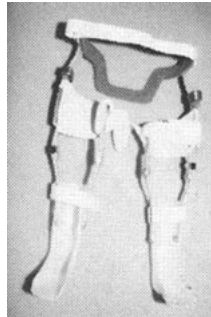
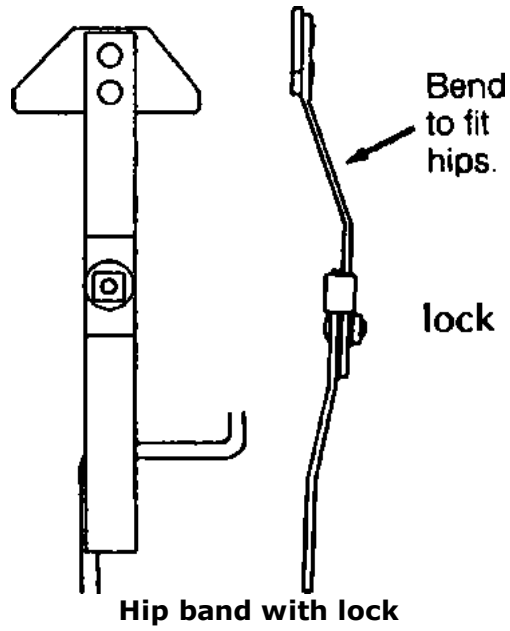

Braces with plastic hip band and locking plastic hip hinges. (PROJIMO)

For a young child whose feet turn in a lot, **a night brace to hold the feet (and hips) turned outward** may help. It can be made from a thin metal bar or from wood.

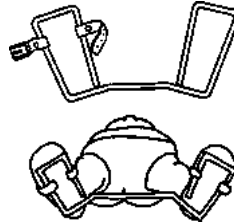

Figure

KNEE PIECES

A child with a weak leg that straightens normally,



Figure

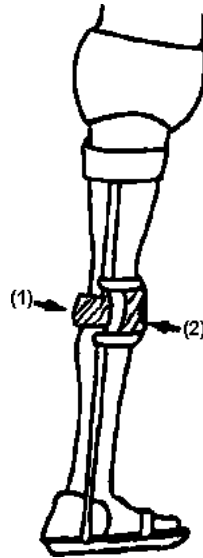

Figure

needs a slightly loose strap behind the knee (1) and a firm, comfortable knee piece (2).

A child with a leg that does not quite straighten,



Figure

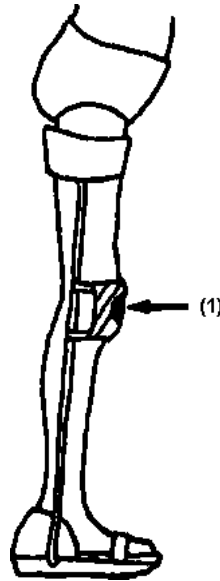

Figure

needs a knee piece that firmly pulls the knee back (1)

A child with a knee that bends backward,



Figure

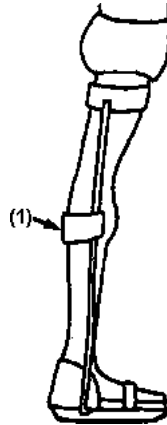

Figure

needs a firm strap behind the knee (1) that lets the knee go back only a little. (A front

strap may also be needed).

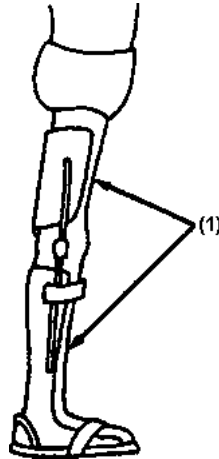

Figure

For children with a severe back-knee problem, it is often better to use a plastic brace that distributes pressure over a wide area (1) above and below the knee. (This is more comfortable than a behind-the-knee strap that presses only on a small area.)

A leg that bends in at the knee, needs a knee piece that pulls the knee outward

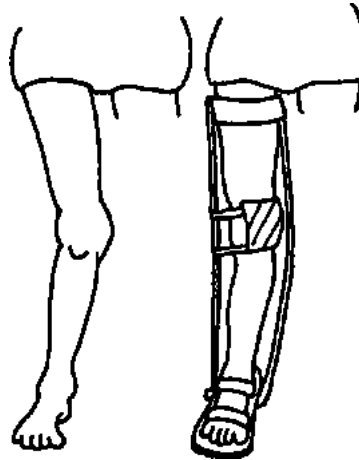

Figure



(1)

Figure

and also one that pulls the knee back (1) (as shown above).

A leg that bends out at the knee, needs a knee piece that pulls the knee inward.

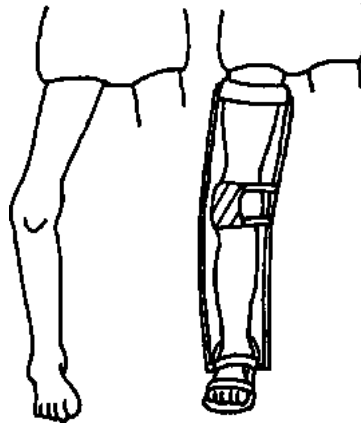

Figure

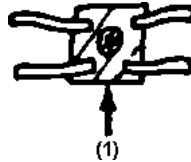

Figure

and also one that pulls the knee back (1).

When necessary, you can use 3 knee pieces:

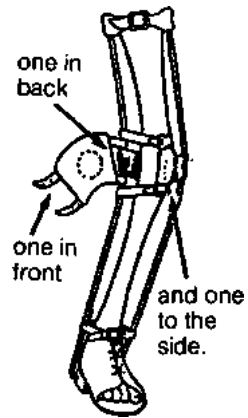

one in
back

one in
front

and one
to the
side.

Figure

ANKLE STRAPS

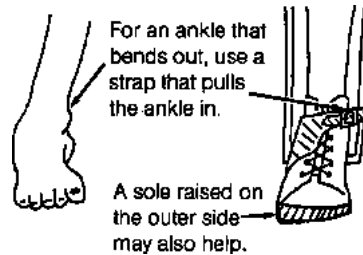

For an ankle that
bends out, use a
strap that pulls
the ankle in.

A sole raised on
the outer side
may also help.

Figure



shape of ankle strap

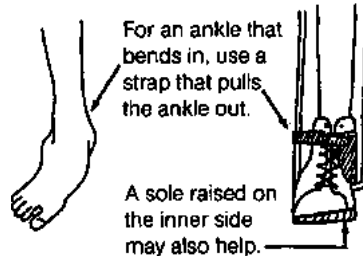

Figure

RAISED SOLES OR 'LIFTS' for one leg that is shorter

For a child who has one leg shorter than the other

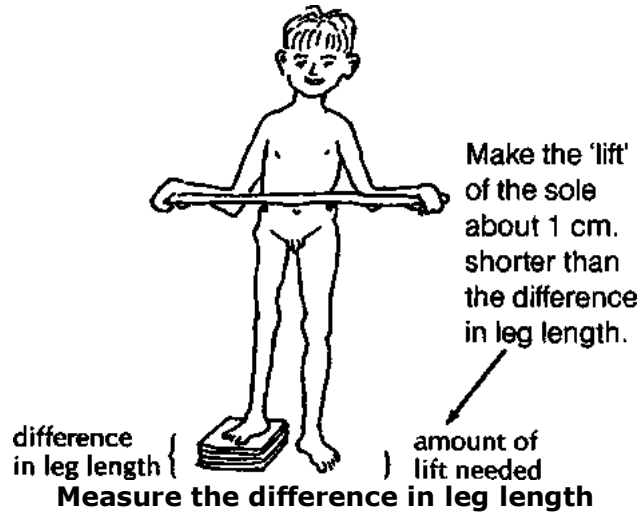

Note: Almost all children have one leg that is a little shorter than the other, and this does not usually affect how they walk. Raised soles ('lifts') are usually not needed if the difference in leg length is less than 2 cm.

However, a child who drags a foot because his hips tilt down on that side may be helped by a small lift on the other side - even if that leg is the same length or longer.

IMPORTANT: Before putting a permanent lift on a shoe or sandal, test it by tying or taping on a temporary lift. Watch the child walk and ask how he likes it. You may want to try several heights before deciding on the one that works best.

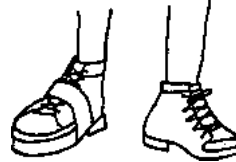

Tie on a temporary lift with string, tape, or a loop of inner tube.

Material used for lifts should be as lightweight as possible. You can use cork or a light, porous rubber. If the material is heavy but strong, to make it lighter you can drill holes through it. Put a thin, strong sole on the bottom.

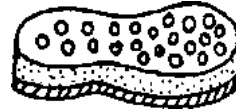

Figure

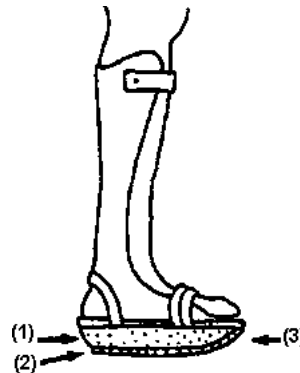

**flat middle section
for firm standing**

flat middle section for firm standing

(1) Back slopes in for a softer heel strike.

(2) For a lift with a stiff-ankle brace, the child can often walk more smoothly with a "rocker-bottom" sole.

(3) rounded in front for easy "roll over" at the end of a step.

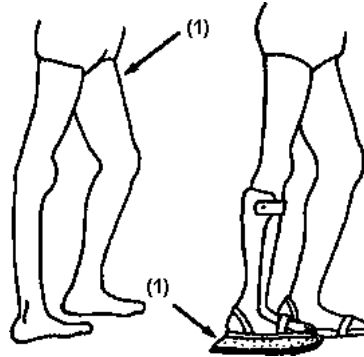

Figure

(1) A child with a mild to moderate "back-knee", may be helped by a heel that extends backward. This helps push the knee forward when the child puts her weight on the foot.

For a more severe back-knee, the child may need a long-leg brace.

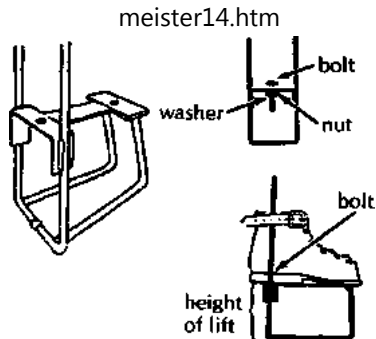

A high lift, when needed, can be built into a bar brace

Design from *Simple Orthopaedic Aids*, by Dartnell

Ask a local shoe or sandal maker to teach you how to fasten on the soles and lifts

PLASTIC BRACES

Below the knee

For most children who need a below-knee brace, plastic braces molded to fit the leg and foot of the individual child have many advantages:

- **They are lightweight and often more comfortable than metal braces.**
- **They fit the child comfortably and exactly (if made well).**
- **They can be worn with ordinary shoes or sandals, which can be easily changed when they get worn out or wet. Shoes can be changed for school and for work.**
- **They are water resistant and easy to clean.**

- They are less noticeable than metal braces. If desired, socks can be worn over them to hide them.
- Children usually prefer them and are more likely to keep wearing them.

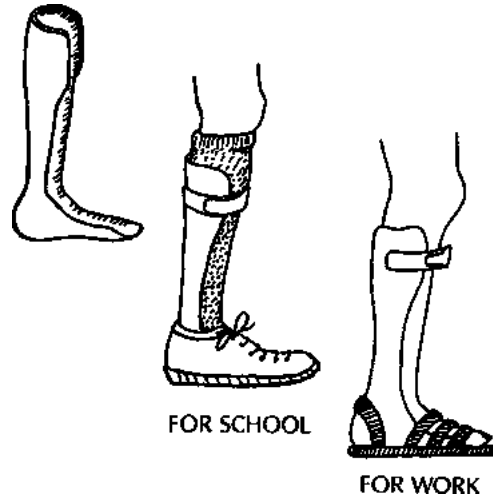

Figure

Although a little more equipment and skill are needed to make plastic braces, once a village worker has learned the basic technique, they can be made as quickly and easily as a simple metal brace with a clog.

A disadvantage to plastic braces is that usually after a year or two the plastic 'gets tired' and breaks. However, growing children need larger braces fairly often. It is wise to keep the plaster mold of each child's brace so that a new brace can be easily made if needed.

A suggestion to save time and money:



Figure

Keep the mold of the child's foot-or have the family keep it.

The biggest expense in making plastic braces is the plaster bandage used for casting a mold of the leg. The cost can be reduced a lot by making your own plaster bandage material.

Plastic braces can feel uncomfortable in hot weather and can lead to skin irritation and fungus *infections* if care is not taken. They can be made cooler by drilling "breathing holes" in them. (1) Or cut out a hole in the back. (2)

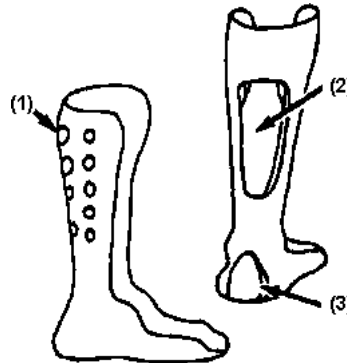

Figure

CAUTION: Do not put breathing holes in the lower part of the brace which has to be the strongest

Sometimes if you cut a hole put behind the heel, the brace rubs less and is more comfortable. (3)

To prevent skin irritation, it is important to bathe daily. It also helps to wear cotton (not nylon) stockings under the brace and to use clean stockings every day.



This design of plastic brace supports the knee from the front and pushes it back.

How to make plastic braces

Here we describe 2 methods for making molded plastic braces:

The first method uses old plastic buckets or containers, and needs less equipment. Unfortunately, these braces tend to break easily when used for walking. However, they make excellent, low-cost night braces (to wear while sleeping).

The second method uses sheets of polypropylene plastic. Additional equipment (such as a vacuum sweeper) is needed, and it is a little more expensive. However, the result is a high-quality brace that can last for months or sometimes years

Method 1: Plastic bucket braces

Equipment and materials needed

- **'stockinette', old stocking or thin cloth strips** (for wrapping leg before casting)
- **plaster bandage** rolls for plaster casts (To reduce costs, roll your own)
- **a sharp knife or single-edged razor blade**
- a piece of **soft rope** about 1/2 meter long
- a piece of old **reinforcing rod**, pipe, or iron bent to fit inside the foot cast
- fast-setting **building plaster** for the solid plaster mold



Figure



Figure



Figure



Figure

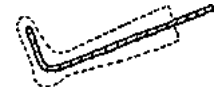

Figure

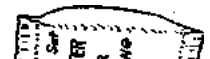

- 2 pieces of wood nailed together to form a **rack** to hold cast in this position
- several **long rubber strips** cut from car tire tubes
- tools for smoothing plaster and plastic **file or rasp**, piece of **broken glass**, piece of **wire screen**
- **large plastic bucket or** containers to be cut up Plastic should be at least 2.5 mm thick and of flexible (not brittle) plastic
- **other buckets or water containers**
- **saw or strong scissors** for cutting plastic
- an **oven** (wood gas or electric)

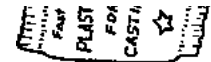

Figure

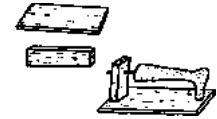

Figure



Figure



Figure



Figure



Figure

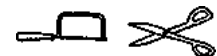

Figure



- large metal **cooking tray** or sheet of metal

- thick **gloves** or potholders

- small **soldering iron**

- if possible a **gas burner, torch,** or 'heat gun' to spot heat the plastic (Note A hair dryer does not give enough heat)

- **drill** and **bits (hand or electric)**

- **strap and buckle** or *Velcro* (plastic straps one with barbs and the other with hairs so that they stick to each other)

- **glue or rivets** or both



Figure



Figure



Figure



Figure



Figure



Figure

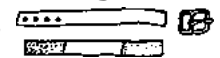

Figure

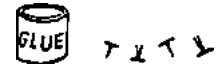

Figure

Making the plastic-bucket brace consists of 3 main steps:

A. Making a hollow plaster cast of B. Making a solid plaster mold C. Heat-molding the plastic-

D:/cd3wddvd/NoExe/.../meister14.htm

the child's leg

of the leg

bucket brace

A. Making the hollow cast

1. Tie a knot in the end of a soft rope.
2. Put the rope on top of the leg with the knot between the toes.
- 3 Put the stocking tightly on the foot with the rope inside (or wrap it with a thin cloth). Avoid wrinkles. Make sure the rope stays very **straight**.
4. Wet a plaster bandage and squeeze out the extra water.
5. Wrap on a thin cast (about 3 layers) while someone else holds the foot in a good position. Be sure the heel is covered with several layers.

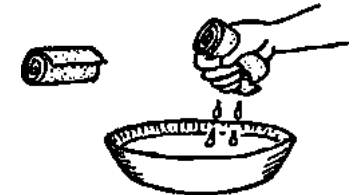

6. While the plaster is still wet, smooth it gently with moist hands, and press the cast gently into all the hollows of the foot.



Figure

7. Before the plaster becomes firm, place the foot in exactly the position that you want the brace to hold it in. Sometimes it works well to hold the foot in your hands. But often it works best to have the child step firmly on the floor, or on a padded board.

Be sure to position the leg **straight up**, from side view and front view.

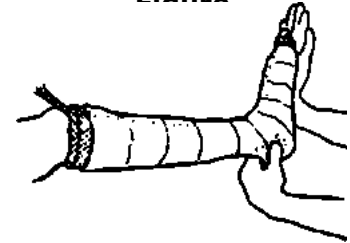

Figure

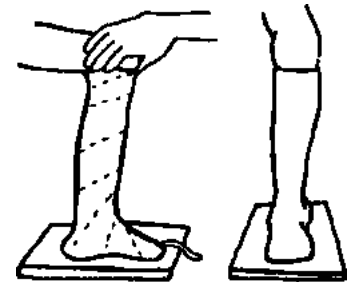

Figure

8. Draw some lines over the front of the cast.

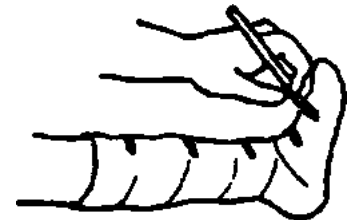

Figure

9. When the cast is almost firm but still damp (usually in 5 to 10 minutes), carefully cut through the plaster over the rope. Take care not to cut the child.



Figure

10. Then gently remove the cast without changing its shape.

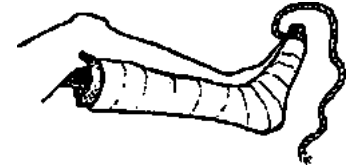

Figure

11. Quickly (before it is fully hard) close the cast, line up the lines you drew, and tie it shut with cloth or string

12. Tie a cloth tightly over the opening of the toes.



Figure

B. Making the solid plaster mold

1. Put a bent piece of rod into the hollow cast.

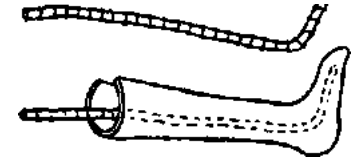
**Figure**

2 Hold the cast in a standing position - perhaps in a box of sand.

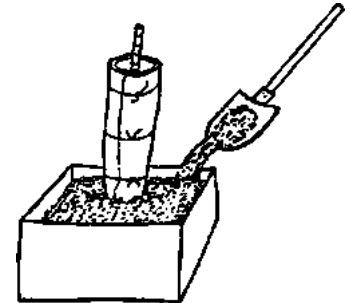
**Figure**

3. Mix the plaster Put water in a container, enough to fill the cast While stirring, sprinkle dry plaster into the water. Keep adding until the mix is just thick enough that wrinkles stay a moment on the surface.

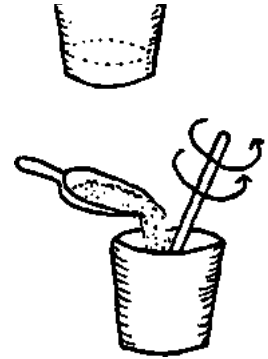

**Figure**

4. Quickly pour the mix into the cast. Jiggle the rod and tap the cast to be sure the mix fills all spaces.

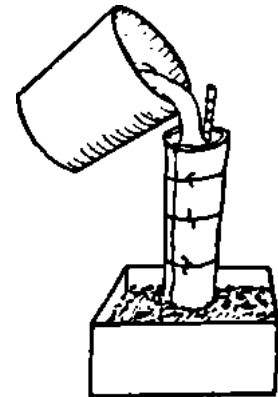
**Figure**

5. Hold the rod in the middle until the plaster is firm.





Figure

6. After plaster hardens fully (about one hour) remove the solid mold.

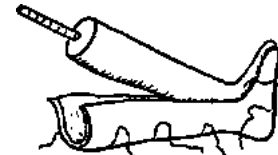

Figure

7. Being careful not to change the shape or size of the mold, use fresh plaster to fill in any holes or pits that are not caused by the shape of the foot. Add a little fresh plaster over bony places (so final brace will not rub).



Figure

8. Smooth the surface (with a file, piece of wire screen, or piece of broken glass). Do **not** reduce any of the bumps caused by the bones.



Figure

C. Heat-molding the plastic-bucket brace

1. Mark on the child's leg the shape of the brace.

2. Take measurements as shown for the width and length of the brace.

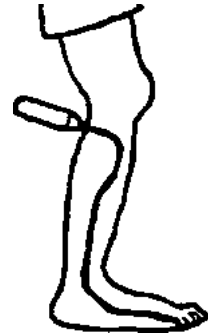

Figure

3. Draw an outline on paper, according to the measurements and cut out the pattern.

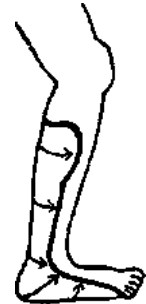

Figure

4. Mark the pattern on the plastic.



Figure



**Figure**

5. Cut out the pattern with a saw or strong scissors.

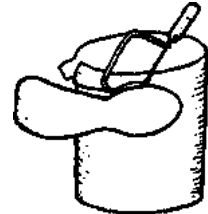
**Figure**

6. Make V-shaped cuts here to help bend the hot plastic around heel.

**Figure**

7. Heat the oven to at least 450° F(230° C) If you cannot measure or control heat, put a small piece of plastic into the oven and heat it until the plastic becomes soft and gooey.

**Figure**

8. Heat the plaster leg cast in the hot oven for 15 to 20 minutes.

**Figure**

9. Put the hot mold on the rack.

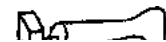

10. Lightly sprinkle dry plaster or talc on a metal sheet or tray

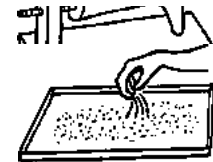

Figure

11. Put the plastic form on tray and put the tray into the hot oven.



Figure

12. Leave it in oven only until plastic becomes somewhat flexible.*

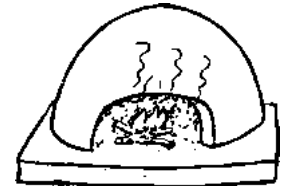

Figure

13. Take hot plastic out of oven with gloves. Bend it over the hot mold.



Figure

14. With strips of rubber, wrap plastic tightly to force it against the mold.

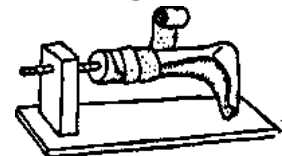

Figure

15. And put it back into oven until plastic gets softer*

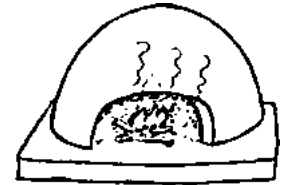

Figure

16. Remove from hot oven and press forcefully (with gloves) to fuse overlapped plastic at heels.

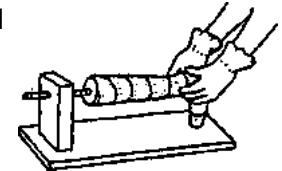

Figure

17. Also press in any hollows around bones and on bottom of foot. Keep pressing until plastic begins to cool and stiffen.



Figure

18. While brace is cooling, heat soldering iron. Heat to moderate heat - nor red hot.

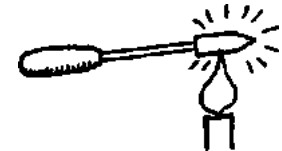

Figure

19 Unwrap cloth from brace while still warm and use soldering iron to smooth and weld heel joint.



20. When cool, trim and smooth the edges of the brace.

21. Glue or rivet a strap near the top of the brace.

For night splints, add 1 or 2 more straps at the ankle and foot (1).

For easier fastening, use **Velcro** straps

For day use, or use with sandals or shoes, only the upper strap is needed.



Figure



Figure



Figure





Note: Braces made from plastic buckets or containers tend to break fairly easily if a larger child uses them for walking. It is better to use polypropylene plastic (see next page).

* Take care not to overheat the plastic, because the plastic used for many buckets and containers tends to wrinkle like bacon when it gets too hot.

Method 2: Polypropylene braces

Polypropylene is a special plastic available in large sheets from orthopedic supply stores and some plastic factories. For most braces, sheets 30 cm. by 60 cm. (1 foot by 2 feet) are large enough. Thickness should be 3 mm. (1/8 inch) for thinner, more flexible braces and 4 mm. to 5 mm. (3/16 inch) for stronger, less flexible braces.

Polypropylene, where available, is usually the best plastic for braces. It is flexible but strong. It is easy to stretch and mold when hot. Cost is US \$1.00 to \$2.00 per brace. **Polyethylene** can also be used but is more likely to wrinkle like bacon if it gets too hot. You can experiment with whatever plastic you find. A program in Pakistan uses **plastic bus windows**, although this hard clear plastic (*Plexiglas*) is more difficult to stretch and shape when hot.

This method is the one used by professional brace makers. Here we simplify it as much as

possible. Equipment and materials needed are mostly the same as in Method 1. However, high-quality braces can be made more easily with a few extra pieces of equipment (they are not absolutely necessary). This extra equipment includes:

- **special oven***

*** Some brace makers in Pakistan use no oven, but simply hold the plastic sheet over a 'chula' (earth pot) of hot coals.**

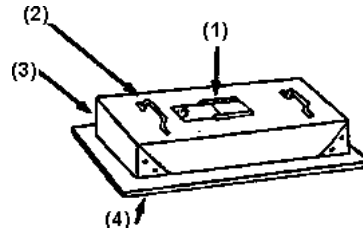

SIMPLE SHEET-METAL BOX OVEN (riveted or soldered together)

(1) window for looking at plastic when it is in healing with sliding or hinged color.

(2) handles

(3) Box should be at least 70 cm. (28 in.) long, 40 cm (16 in.) wide and 10 cm (4 in.) high

(4) sheet of metal (preferably aluminium, because it spreads heat best) at least 6 mm (1/4 to 1/2 in.) thick.

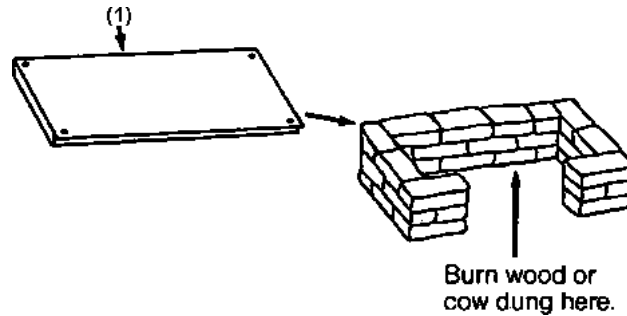

Figure

If you can get it, rivet a piece of "Teflon" cloth over the metal sheet (1). This will help keep the hot plastic from sticking to the metal. Or you can use a *Teflon* spray.

The "oven" can be placed over any source of heat. Use the cooking fire, or if you want to build a simple fireplace to support it.

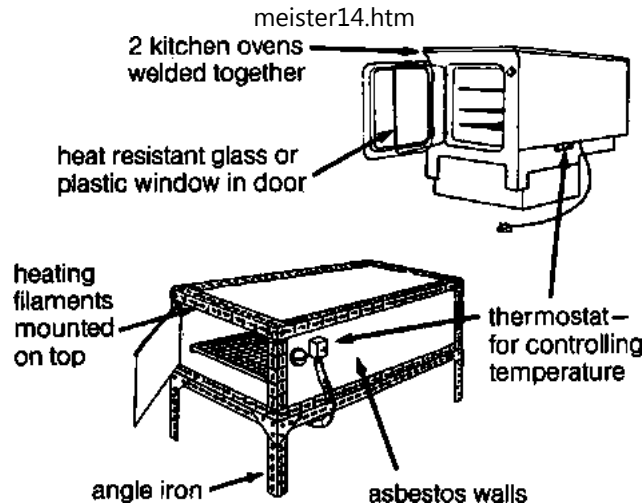

COMPLEX GAS OR ELECTRIC OVENS (designs from Huckstep's Poliomyelitis.)

- vacuum sweeper

(if electricity is available) or other form of suction. (The suction pulls the hot plastic tightly against the cast until it cools. However, this is not absolutely necessary.)

- metal pipe



Figure

Tape it to the end of the vacuum sweeper hose.

The pipe should be a little bigger than the rod used in the leg cast. By bending the rod

slightly, it will fit very tightly into the pipe.

Figure out some way to clamp or bolt the pipe firmly to a strong bench or table.

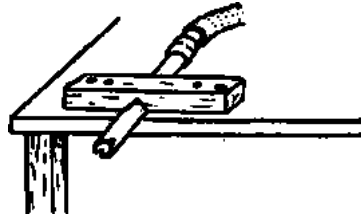

Figure



Figure

Put 2 notches in the pipe (1) so it will breathe when pushed up against the plaster.

• **electric cast-cutter**

These are *very* expensive but a great help if you are making a lot of plastic braces.

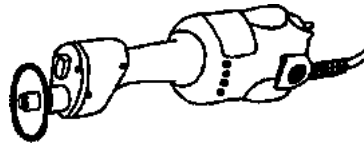

Figure

If you do not have a cast-cutter you may have to use a hammer and chisel to cut the plastic. You can heat the chisel so that it will melt the plastic.

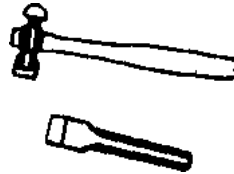

Figure

Making the polypropylene (or polyethylene) brace

Steps A and B are the same as described for Method 1.

Step C. Heat-molding the plastic brace

1 Put the rod of the plaster mold into the vacuum pipe. Be sure it is very tight (If not, take it out and bend the rod a bit more)



Figure

2 Stretch stockinette or stocking tightly over the cast and tape it to the pipe



Figure

3 Sprinkle dry plaster powder or talc over the entire foot and smooth it with your fingers



4 Preheat the oven and sprinkle plaster powder or talc evenly over the hot metal sheet

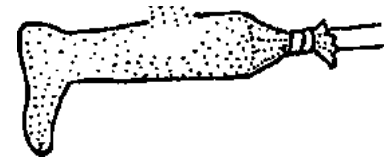

Figure

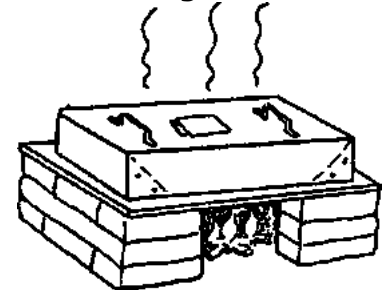

Figure

5 Cut a piece of polypropylene plastic large enough to stretch around the entire foot, and put it into the oven to heat

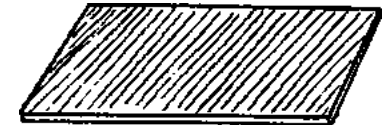

Figure

6 As the plastic gets hot enough to mold, it will turn clear so you can easily see through it. It often gets clear in the middle first

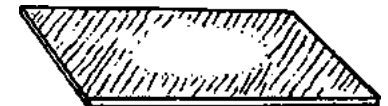

Figure

7 To move the hot plastic, 2 persons must wear thick gloves. Sprinkle dry plaster powder, lime, or talc on them



8 As the plastic is getting hot, turn on the suction (vacuum cleaner) and listen for a hissing sound where the pipe joins the cast (This means the suction is working)

9 When the plastic is hot enough (clear and limp), remove the oven lid, lift the hot plastic by its 4 corners and quickly stretch it over the whole cast

10 Quickly pinch the edges of the plastic together along the bottom side of the leg and around the pipe. Squeeze together all edges to form a seal. You **must work quickly** to complete the seal before the plastic gets too cool

As soon as the seal is complete the suction should pull the hot plastic close against the cast. But if necessary help by pushing it into the hollows *

11 While the plastic is still hot and soft cut off the extra with a sharp



Figure

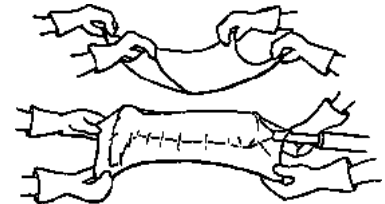

Figure



Figure



11 While the plastic is still hot and soft cut off the extra with a sharp knife or strong scissors

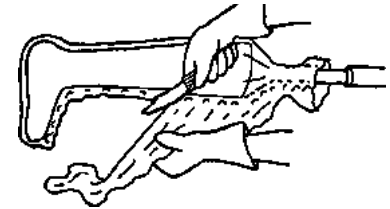

Figure

12 After it cools, draw the form of the brace on the plastic,

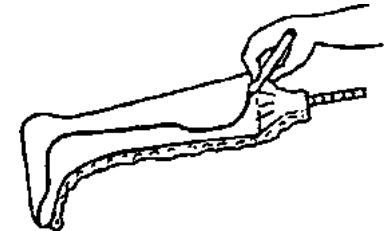

Figure

13 and cut it out either with a cast cutter,

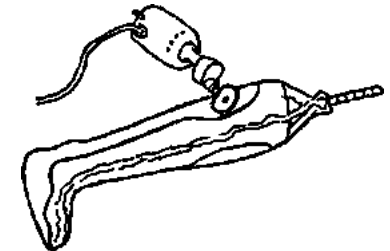

Figure

or a hammer and chisel,

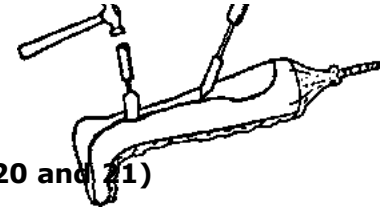

or a red hot soldering iron, or however you can

Finish the brace in the way described under Method 1 (steps 20 and 21)

*** If no suction equipment is available, you can heat mold the plastic by stretching it over the cast and pushing in the hollows until it cools. With practice, this gives almost as good results, and you only need about half as much plastic.**

Making sure plastic braces fit well and are comfortable

The most common problem with plastic braces is that they press on bony bumps. To avoid this,

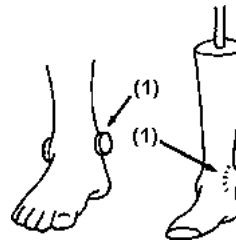

Figure

put small pads over bony bumps before casting foot. Or, put the pads on the mold, and add a little fresh plaster to the bony bumps before molding the plastic (1).

Soft padding inside the brace can make it more comfortable. Places that may need to be padded are:

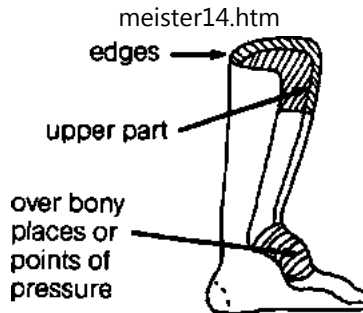

Figure

When the child wears the plastic brace, if it presses too much on bony places, or elsewhere, heat a small area over the spot where the bone presses, and with a smooth, rounded stick push the hollow deeper. (Use a heat gun if you have one.)

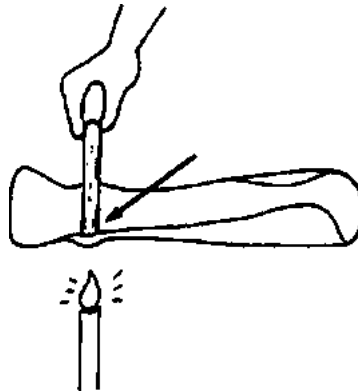

Figure

For padding you can use a product called 'moleskin', or a special foam plastic material

available from orthopedic supply stores. Or you can glue in pieces of cotton blanket or car inner tube (but make sure the child wears cotton stockings to avoid skin problems).

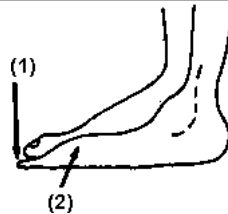

Figure

The sole (1) of the brace can end at the ends of the toes (or slightly beyond to allow the growth)

The side (2) of the brace at the foot can extend to the toes if necessary for support.

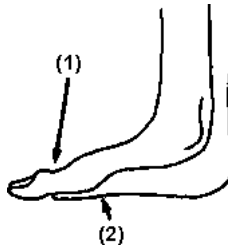

Figure

Or the sole can end at the base of the toes (1).

For better comfort and shoe fit, the side can dip down around the base of the big toe (2).

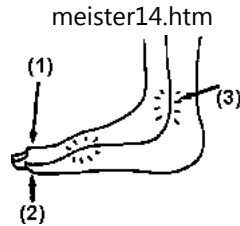
**Figure**

AVOID brace edges that stop at middle of toes (1).

Avoid an edge that curves in (better to heat it and bend it out a time) (2).

AVOID brace edges that pass across the middle of bony bumps. The edge should be either behind or in front of the bump (3).

Deciding how wide or narrow to make the sides of the brace at different points will depend on the needs of the particular child.

A child whose ankle or foot is floppy or deformed, or who needs a stiff ankle brace to push back a weak knee may need a brace with wide sides at the ankle and foot.

**Figure**

A child who needs only the ankle stabilized may walk better with a brace that lets the

front of the foot bend up and down a little.

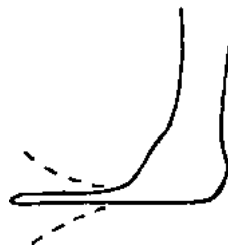

Figure

Many children benefit by a brace that allows some up and down ankle movement but prevents sideways movement.

This can be done by cutting back the sides of the brace here.

This will be the weak point in the brace. So , the plastic must be extra thick here.



Figure

Or you can strengthen it by putting extra strips of hot plastic on the back of the plaster mold *before* stretching the whole plastic over it.



Figure

Different plastic brace models for different needs

In various places in this book we have shown different brace models and how they meet the particular needs of a child. Here are a few more ideas for different plastic braces:

Below-knee brace that gives knee support

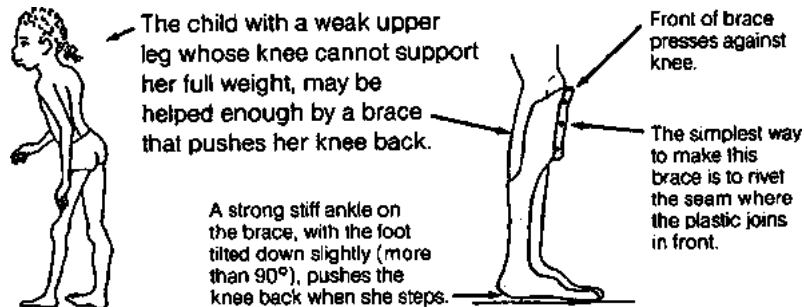

Figure

CAUTION: The shoe or sandal may affect the angle of the foot. Allow for this when deciding the angle for the foot of the brace.



Figure

A similar brace can be made in 2 parts

1. Make the lower part, and place it back on the plaster mold



Figure

2. Place the mold like this and form the top part of the brace over the lower part

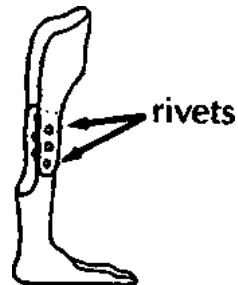

Figure

When the child grows, this brace can be made longer by removing the rivets and separating the 2 ends more

Side-support knee brace

A brace that supports the knee may help a child that has a sideways bend or partial dislocation of the knee

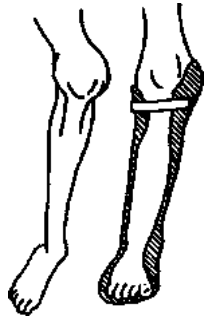

Make the brace higher on the side that needs more support

Figure

Also make the brace higher on the side of the ankle that needs more support



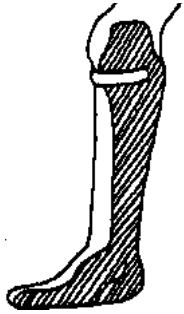

Figure

Also, in an above-knee brace, you can put extra support on the side of the knee that needs it.

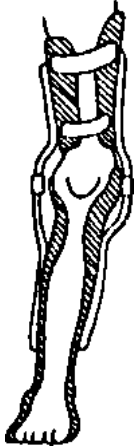

Figure

Above-knee plastic braces

The simplest kind of above-knee plastic brace is a single piece without a knee hinge. You

can make it in the same way as a below-knee brace, with or without a footpiece. These braces are useful on small children

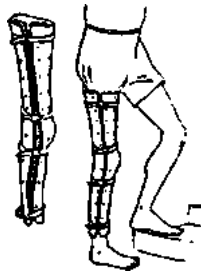

Figure

To make a jointed above-knee brace:

- 1 Draw the shape of the child's leg on paper
- 2 Mark the height of the



Figure

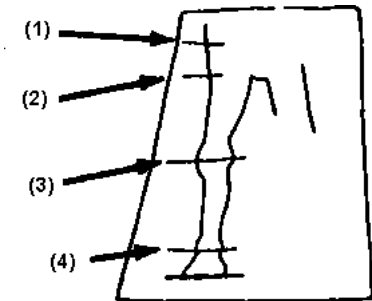

Figure

hip bone (1)

- crotch (2)
- mid-knee (3)
- ankle bone (4)

3 After forming the plastic pieces on plaster molds, bend metal joint pieces so they fit the shape of the leg

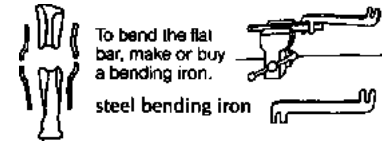

4 Temporarily pin or bolt the plastic pieces to the metal pieces. Then you can adjust the front-to-back angles with the brace on the child

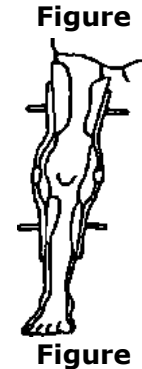

5 When the angles are right, mark the position, and after checking all aspects of fit, rivet the pieces together and add straps and knee supports

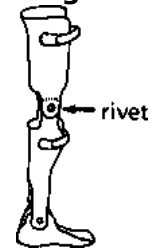

Hinged braces can also be made using the plastic itself for knee hinges.
And even ankle hinges
However, these hinges may not last long with heavy use.

**Figure****Figure**

BODY SUPPORTS

**Figure**

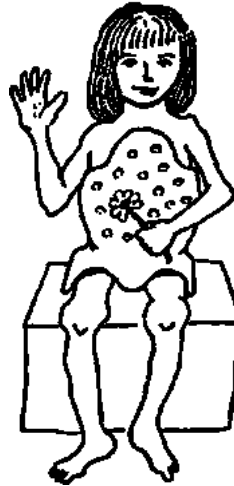

Figure

In most cases, a body brace or body jacket probably does little or nothing to correct or prevent further curving of the spine. However, a child with a 'flail' spine that curves so much that it makes sitting difficult or awkward, may sit more comfortably and have more use of her arms if she has a body brace

Making a plastic body brace

- 1 Put small pads over upper outer corners of hip bone



Figure

2 Put a stockinette or old tight-fitting shirt on the child



3 Cast the child's body with plaster bandage while holding her in a sitting position*. While the plaster dries hold the child as straight as you can. Bring plaster down to the level of the seat.

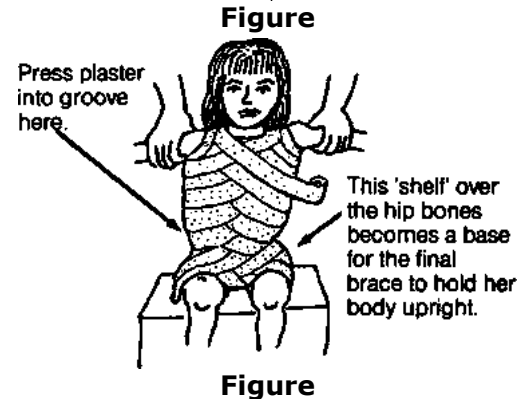

4 Cut the cast into 2 halves and remove



5 Tape or tie the 2 halves of the cast together and put it into a plastic bag



Figure

6 Make a solid plaster mold inside the cast



7 Remove the plaster mold and smooth it carefully to keep its shape especially the waist and hip curves. You can make it lighter and save plaster by mixing sawdust or bits of plastic foam into the plaster

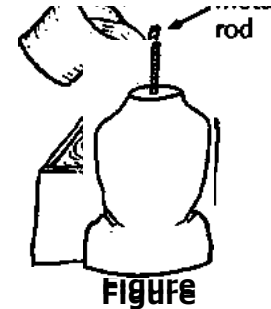

8 Stretch hot plastic over the mold as described. If your oven or sheets of plastic are not big enough you may have to mold it in 2 halves front and back

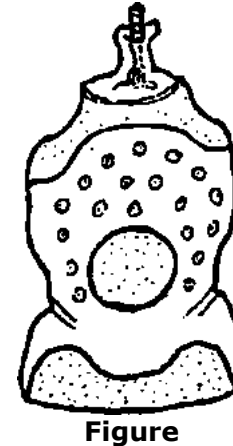

9 Mark and cut the plastic. Leave a little room under arms. Cut breathing holes and perhaps a large central hole over the stomach

10 Try it on the child. Make adjustments. Smooth edges. Add padding and straps. The bottom of the brace should just touch the seat when the child seats.



Figure

A body brace attached to leg braces may be needed by a child whose body is weak from the chest down





*** Casting can also be done with the child lying lengthwise over a wide strip of cloth stretched between two points**

Figure

Chapter 59: Correcting Joint Contractures

In this chapter we discuss different aids used for gradually straightening limbs that have joint *contractures*.

Information on contractures, their causes and prevention is in Chapter 8. Exercises to prevent and correct contractures are in Chapter 42.

Joint contractures can often be gradually straightened with casts or braces that gently but firmly hold the joint in a stretched position for a long time. We stress gently because unless great care is taken it is very easy to cause injuries.

To straighten a limb, 3 areas of pressure are needed

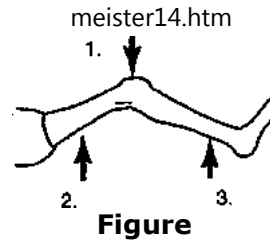

In theory, the leg could be straightened like this

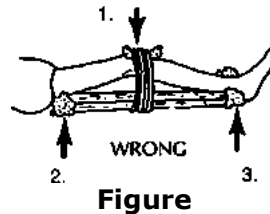

In fact, this would cause pressure sores on the small areas where the splint presses (1).

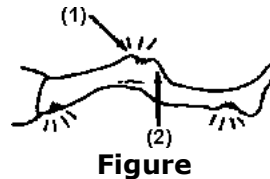

Also, the knee (2) could be *dislocated* if the calf is not supported while stretching.

Always use wide areas of pressure. Avoid pressure on the knee, behind the heel, and over bony areas.

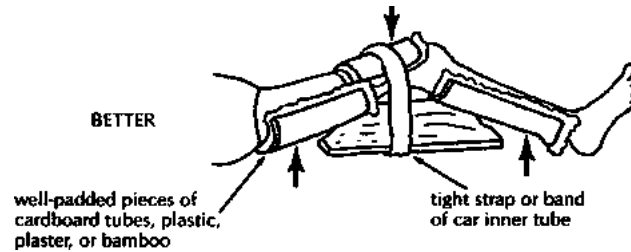

Figure

If a child stays in bed, a stretching aid like one of these might work. (But try to keep the hip straight, so that the aid does not cause a hip contracture while it straightens the knee.)

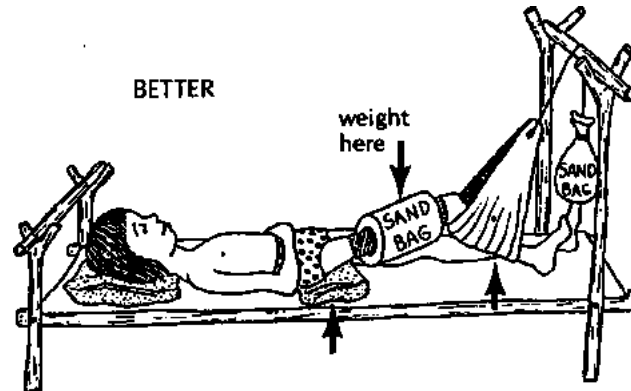

Figure

There are several ways to straighten contractures that let the child continue to move about. These include:

1. a series of plaster casts

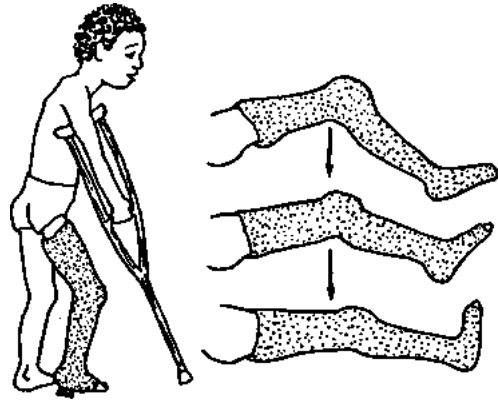

Figure

2. adjustable braces

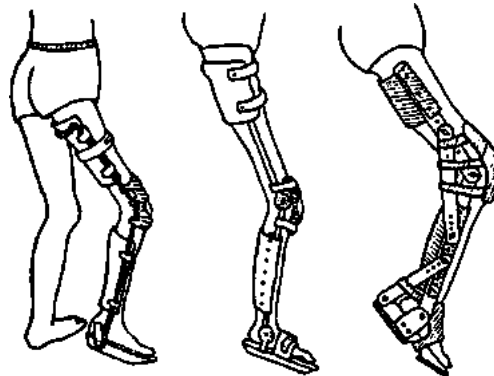

Figure

3. elastic stretching aids of bamboo or inner tube

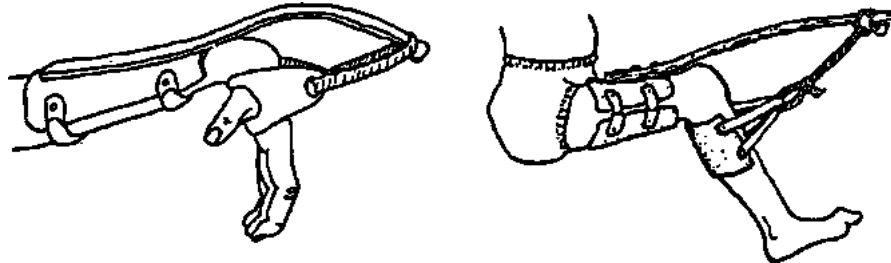

Figure

4. adhesive strapping

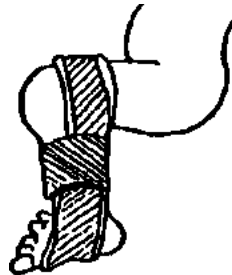

Figure

The advantages and disadvantages of the first 3 ways are discussed. It is important that you read this before deciding which one to use for a particular child. The 4th method (strapping) is used mostly on clubbed feet of newborn babies.

HOW TO CORRECT CONTRACTURES USING PLASTER CASTS

The example we give here is for the knee, but the basic methods are the same for contractures in ankles, feet, elbows, and wrists.



Correcting contractures with casts. (PROJIMO)

Casting the leg

FIRST WEEK

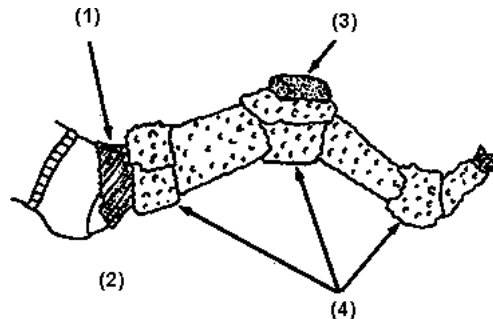

Figure

- (1) Put stockinette or a close fitting cotton on the leg. Avoid wrinkles**
- (2) Put cast padding or cotton roll (or wild kapok) evenly around the leg.**
- (3) To protect the knee, it helps to put a soft sponge or piece of sponge rubber over the knee.**
- (4) Put extra padding around the thigh, the knee and the ankle**

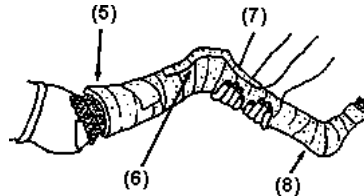

Figure

- (5) Put a plaster cast on the leg. Be sure it reaches high up the thigh.**
- (6) Put lengthwise strips of plaster for reinforcement over the knee.**
- (7) Holding the calf below the knee, gently straighten the leg as far as it will go, without using force.**
- (8) Position the foot at a right angle (or as near to it as you can without using force).**

STRAIGHTENING THE CAST WITH WEDGES

The cast is straightened a little every few days. In a small child or a person with recent contractures it can be done every 2 or 3 days. In persons with old contractures progress

will be slower. To save on costs change the cast every week or 10 days

SECOND WEEK

1. Cut through the plaster behind the knee.

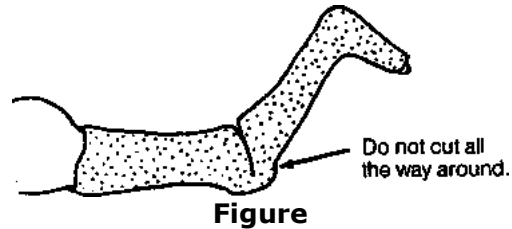

2 Use steady gentle pressure so that the leg straightens a little and the cut opens.

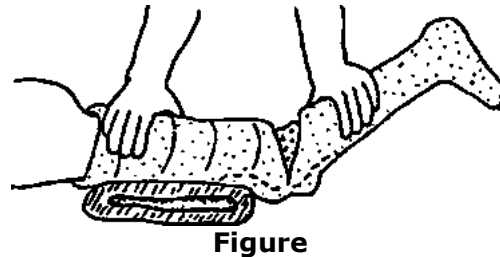

3 Hold the cut open with a small wedge of wood

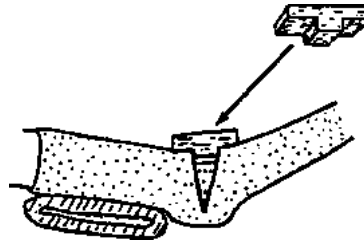

Figure

4 Wrap a piece of cloth around the knee

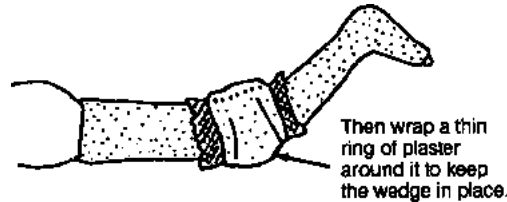

Figure

Then wrap a thin ring of plaster around it to keep the wedge in place.

CAUTION: When stretching the leg use gentle steady pressure until **it begins to hurt a little**. Do not try to advance too fast as you may cause permanent damage to *nerves, tendons*, or the joint

For a day or so after stretching the child may have some discomfort behind the knee. This is normal unless it hurts too much. You can give aspirin. If the child complains of pain over pressure points or bony bumps remove the cast or cut open a window in the cast to check if a sore is forming

WARNING: When casting a child who does not feel in his limbs take great caution to avoid pressure sores and use very little pressure

THIRD WEEK

1 Cut and remove the ring of plaster

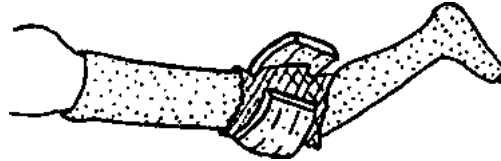

Figure

2 Gently stretch the joint and put in a wider wedge

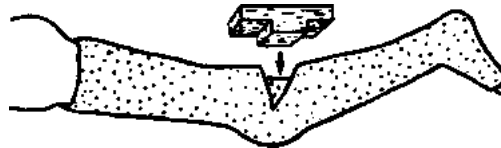

Figure

3 And cover it with a new ring of plaster

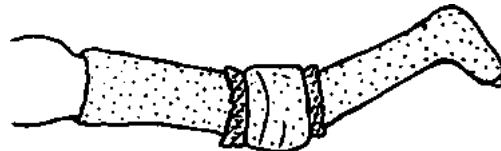

Figure

FOURTH WEEK

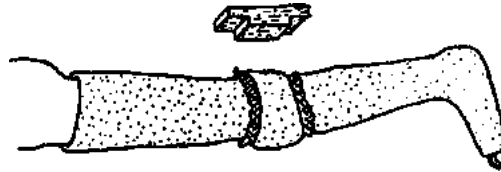

Each time you change the ring put in a bigger wedge

FIFTH WEEK

Continue casting until the knee is completely straight or bends backward just a little. Then use a brace for at least a few weeks (day and night) to keep it straight

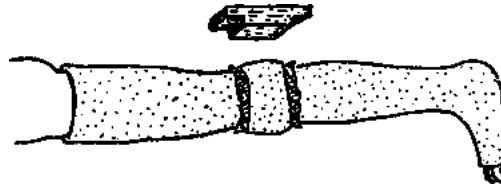

Figure

SIXTH WEEK

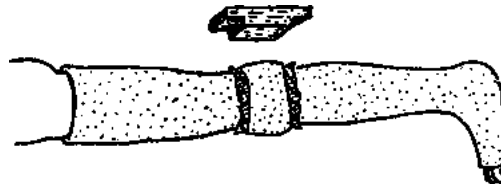

Figure

The time to straighten a contracture may vary between 2 weeks and 6 months - or more.

If the leg stops straightening for 3 or more cast changes stop casting and try to arrange surgery

Straightening a leg that is hard to stretch

In an older child who has a knee contracture with strong *muscles* that bend the knee, it may be hard to straighten the knee more with each cast change



STRONG MUSCLE HERE

If the leg does not move when you pull it ask the child to



Figure

When he relaxes keep pulling and the leg should straighten a little

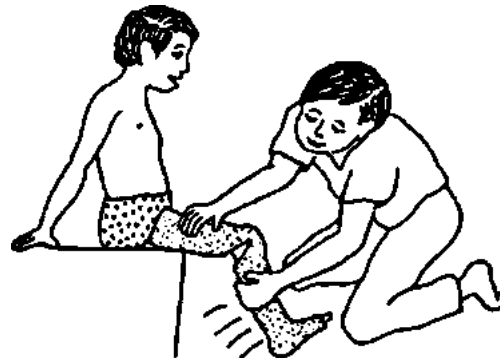

Figure

Repeat this several times while you steadily pull the leg. Each time the knee should straighten a little more.

Straightening a tiptoe contracture

A foot with a contracture like this,

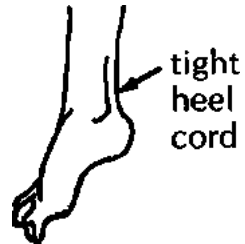

Figure

can sometimes be straightened with casts and wedges

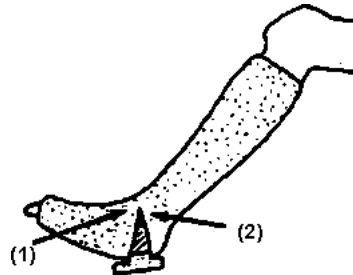

Figure

Put lots of padding under the on top of the ankle(1).

Be sure the cut reaches (2) fairly high up the ankle (not across the top of the foot.)

Try to overcorrect the contracture so that it will rest easily at a (90°) right angle when the cast is removed

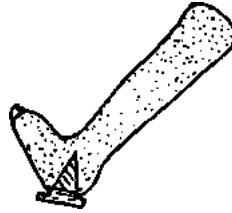

Figure

Do not let the child walk on the cast until the day after it is put on-and then only if you put a walking heel on it. Otherwise the sole of the cast will become floppy and will not help. Active children need very thick plaster on the bottom of the foot.

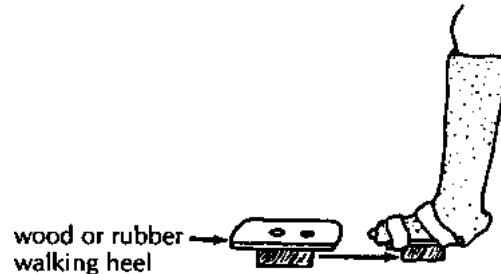

Figure

CAUTION The above method of correcting tiptoe contractures

To prevent pressure sores it often works

For more precautions

sometimes causes pressure sores here

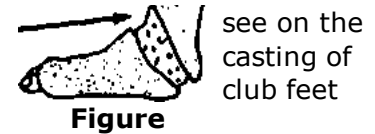
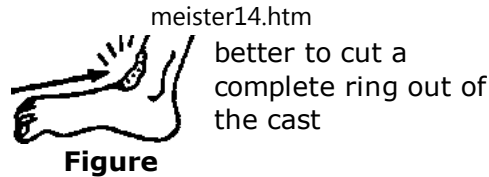

For the child who lives too far away to have her cast changed every few days, you can try to make an aid that will gradually pull the foot up without needing frequent cast changes. Here is one idea

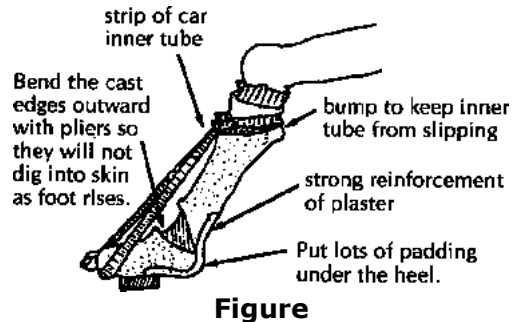

CAUTION: If the child is sent home with a cast **be sure the family knows the danger signs.** If any of these appear have them quickly bring the child back or remove the cast themselves

Danger signs:

- constant severe pain - especially in areas where pressure sores can occur
- a darkening or change of color in the toes
- numbness or burning
- a smell like rotting meat (a late very serious sign)

To take off the cast without tools, in an emergency soak it in warm water and unwrap or tear it apart

Note: This cast is not as strong as a fully covered one and will not last on a very active child. It will usually only work on a child without much sideways deformity of the foot or ankle. The cast may need to be changed 2 or 3 times as the foot straightens

HOW TO CORRECT CONTRACTURES USING ADJUSTABLE BRACES

The advantage of these braces is that children do not have to visit the *rehabilitation* center so often to have them adjusted. The family can adjust them at home.

Orthopedic suppliers in some countries sell special knee and ankle joints that can be locked in different positions. But these are very expensive. However, a skilled village craftsman can put together something similar:

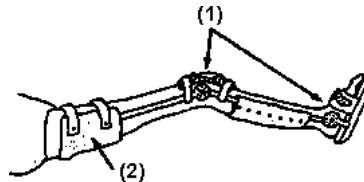

Figure

Knee and ankle joints can be adjusted every few days to gradually straighten the joints (1).

(2) leather or plastic cuffs.

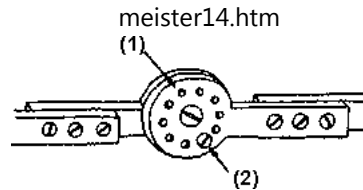

Figure

Space the holes on the 2 pieces differently (1) so that lining them up allows a range of small adjustments.

(2) adjustment screw or pin

A much simpler low-cost model can be made of round or flat metal bar.

Round metal rod (re-bar)

Bend rod just a little less than knee will straighten

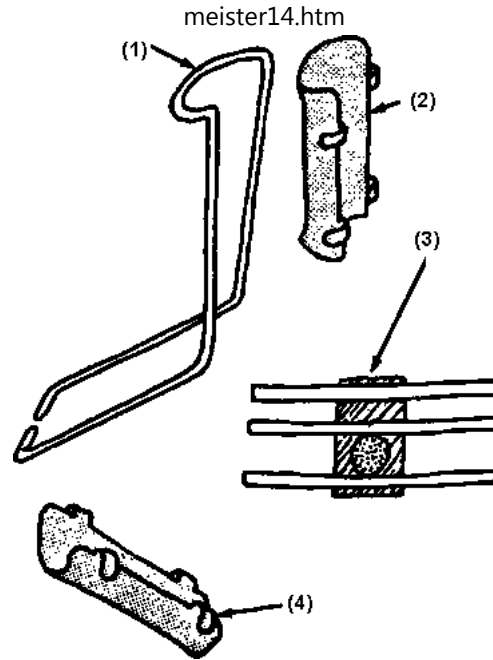

Figure

- (1) rod about 80 mm (1/4 inch) thick (depends on the size of child)
- (2) plastic heat-molded to fit leg, or simply bent with heat (or use leather)
- (4) knee pad with extra width above knee
- (5) tabs bent back with heat to grip bar

These metal bar braces are used in a way similar to a standard above-knee brace. Every 2 or 3 days, bend the bar a little straighter at the knee. The brace can be made cheaply, and can be removed for walking and exercise, and to check for sores. As the leg becomes straighter, any of

these braces can be used as a regular walking brace with a **clog**.



Figure

Flat metal bar

Use flat steel bar that is strong enough to hold leg firmly.



Figure

Twist the middle part of the bar in a vise so that it can be bent for easy adjustments



Figure

Two designs for adjustable braces to correct ankle contractures

1.

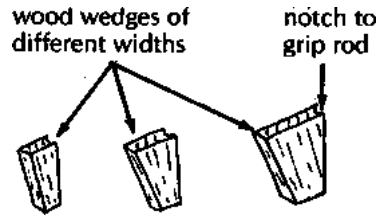

Figure

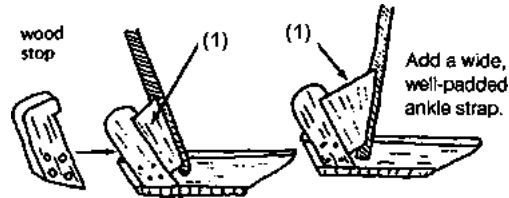

Figure

(1) Fit different wedges between stop and rod to change adjustment.

Note: This design is complicated to make but can be adjusted while the brace is on the child

2.

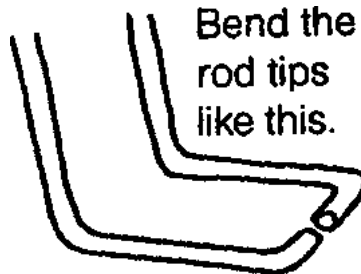

Figure

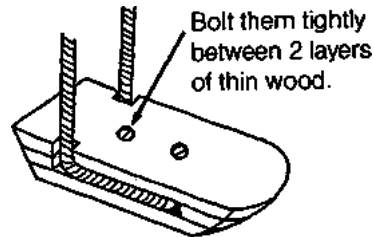

Figure

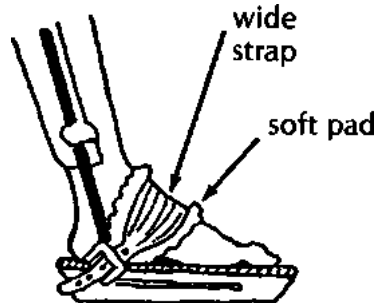

Figure

Bend rods up a little more every few days.

An adjustable wood brace for knee and ankle contractures

The positions of these 2 cross pieces can be changed to adjust the angle of the knee and foot

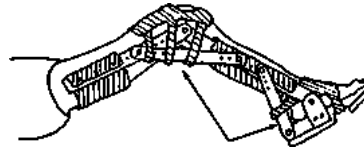

Figure

Using "wing nuts" makes it easier to remove the bolts for clamping the position of the cross pieces.



Figure

Use thin pieces of hard wood about 2 cm wide and 6 to 8 mm thick

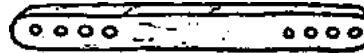

Figure

WARNING:

If a knee looks like this, it is probably dislocated. Trying to straighten it could make the dislocation worse. Take great care to put pressure only on the leg just below and behind the knee, not at the foot. Gradually try to correct the dislocation (bring the lower leg forward) before trying to straighten. If possible, get advice or help from an experienced health worker or specialist



Figure

Chapter 60: Correcting Club Feet

***Note:* In Chapter 11 we discussed club feet. We suggest you read before trying to correct a club foot.**

The younger a child is when you begin, the more easily and quickly her foot can be straightened. For best results, begin 2 days after the baby is born. If the child is over 1 year old, usually a good correction is only possible with surgery. Ways to predict how easy or difficult correction may be for a particular child are listed.



club foot

Method 1: STRAPPING

This method works well in a baby with mild to moderate clubbing, especially when the foot can be put into a nearly normal position. The method is easier and cheaper than casting, and sometimes gives better results. You will need:

- **tincture of benzoin (to paint on the skin to help the adhesive felt stick firmly. Zinc oxide in the tincture will help protect the skin.)**
- **cotton wool**
- **adhesive surgical felt (padding) 8 mm. thick and at least 2.5 cm (1 inch) wide**
- **adhesive tape (sticking plaster) or zinc oxide strapping 2.5 cm. wide**

1. Paint tincture of benzoin on the skin areas to be covered by the tape.

2. Hold the baby's foot like this and gently straighten it as far as you can without forcing.



Figure

3. With the knee bent as far as possible, stick strips of felt around the foot and over the knee and leg as shown

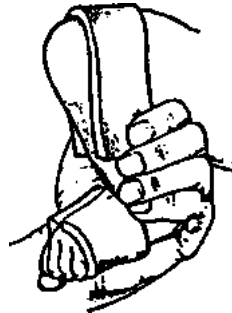

SIDE VIEW

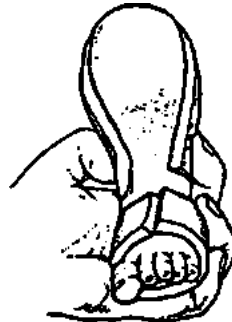

FRONT VIEW

4. Stretch adhesive tape over the felt. Start on the outer side of the foot, go around the foot, up over the knee, and down the other side. Use the tape to pull the foot into a better position.

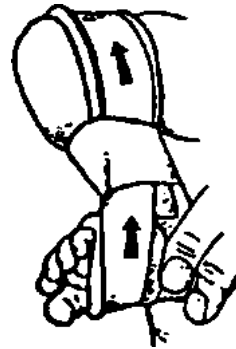

SIDE VIEW



FRONT VIEW

5. Put a second piece of tape around the leg twice here to hold the first tape.

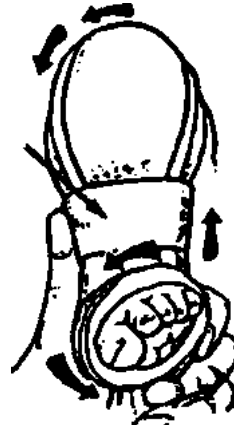

FRONT VIEW

CAUTION: 10 minutes after putting on the tape, check to see if any part of the foot has turned dark. If so, look for the trouble spot and try to adjust the strapping. If it stays dark, take everything off and start again

Every 2 or 3 days, tighten the correction by stretching new tape over the old, in the same way. On the 7th day, remove everything and leave the leg free until the next day. On the 8th day, apply new felt and tape.

Exercises during strapping

While the baby's foot is strapped, someone in the family should do stretching exercises on his foot every time he is fed or changed (at least 8 times a day).

1. Hold the baby's leg like this and turn his whole foot UP and OUT.

Hold and count to 10. Repeat 10 times.



Figure

2. Turn it as if you were trying to touch the little toe to the outer side of the knee.

The strapping and exercises should be continued until the foot is oval-corrected (bends outward a little).

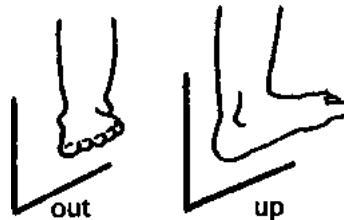

Figure

3. If the foot is shaped like a bean, also do an exercise to stretch the foot in the opposite direction of the deformity, like this.



Figure

4. After stretching the baby's foot this way, help the baby to stretch it himself by tickling the outer edge of his foot.

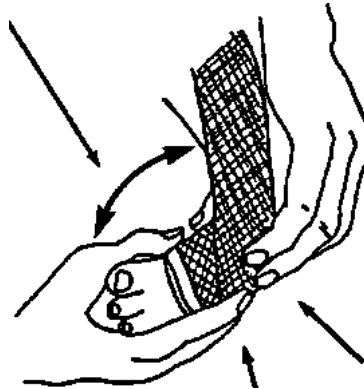

Figure

If the foot is not straightened completely within about 3 months of strapping and

exercises, surgery is probably needed.

Method 2: PLASTER CASTS

This method uses a casting technique similar to the one for correcting contractures (see Chapter 59). A club foot is gradually straightened in 3 stages:

Stage A →

Straighten the inward bend so that the foot points **down**. Do not yet begin to lift the foot.

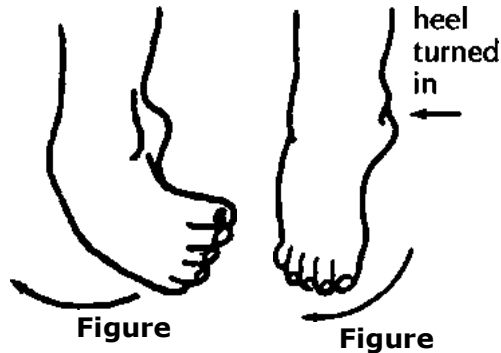

Stage B →

Overcorrect so that the foot points **down** and **out**. Keep the foot in this position **until the heel no longer turns** in but is straight or turns out just a little.

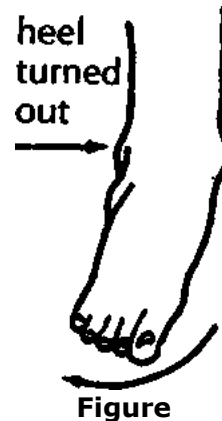

Stage C

Now bring the foot **up**, making sure that the outside of the foot is higher than the inside. **Overcorrect**.

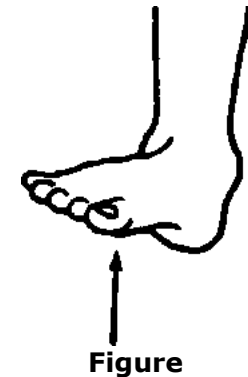

Stage A

1. In a young baby it is often necessary to **cast the whole leg with the knee bent** to keep the cast from slipping down. First, wrap cotton padding evenly around the whole leg.

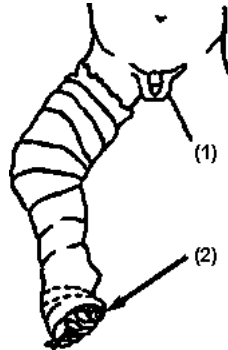

Figure

Put extra thick padding over bony spots (1).

Put bits of cotton between the toes (2) (Take them out after the foot has been cast).

2. Cast the leg and foot. Make the cast especially thick around the knee and heel, where he is more likely to bump it.

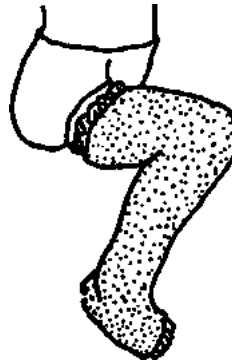

Figure

3. After the plaster is dry, cut out a wide ring from heel to mid-foot.

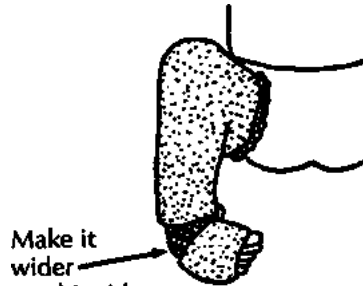

Figure

4. Gently and slowly begin to stretch the foot OUT and DOWN. (Do not try to bring it up yet.)

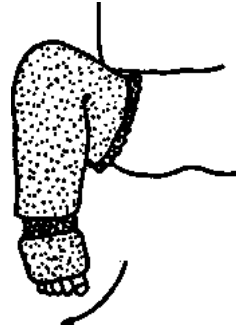

Figure

5. To keep edges of cast from hurting the skin, bend - them out with pliers.

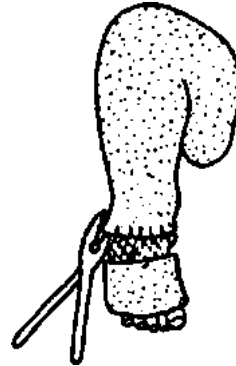

Figure

6. Put a ring of cotton or soft gauze over the foot and cover with new plaster bandage.

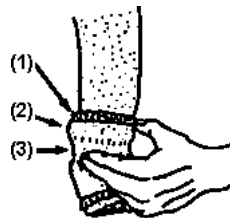

Figure

(1) gauze

(2) new plaster

(3) Press the soft plaster into groove and smooth with fingers.

Hold the foot in the new position until the plaster hardens.

7. Once or twice a week take off the outer ring of plaster, bend the foot down and out a little more, and cover with a new ring of plaster.



Figure

Repeat Step 7 until the foot bends outward a little. This usually takes several weeks.

Stage B

1. Remove the whole cast and check the position of the heel.



Figure

Often the heel still bends in even after the bend of the foot has been corrected.



Figure

2. If so, keep casting the foot in a **down** and **out** position until the heel is straighter.

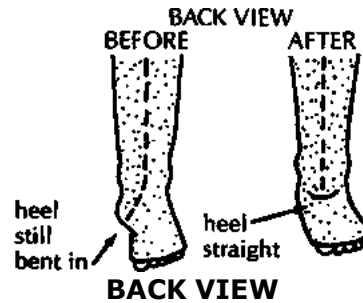

Stage C

1. After the sideways twist of the foot and heel is corrected, begin to raise the foot, using casts.
2. As you wrap the foot with plaster bandage, hold it in a raised position with 2 fingers.

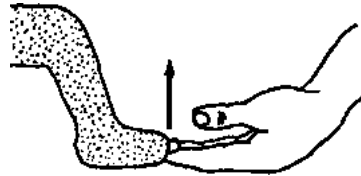
**Figure**

3. Hold the foot up as the plaster dries.

**Figure**

As you hold the foot, keep it turned outward so that the little toe is always higher than the big toe.



Figure

Take care to keep the toes straight.



Figure

4. Keep raising the foot little by little using the same casting method as before.

Bend up cast edges with pliers.



Figure

(CAUTION: Be very careful cast does not pinch or dig into skin here.)



Figure

5. Raise the foot a little in this way once or twice a week until it is as high as this. or until it stops raising for 3 or 4 cast changes.

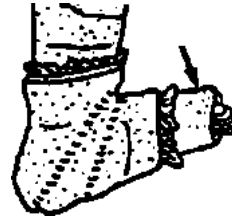

Figure

This child was born with a club foot. Village *rehabilitation* workers used a series of casts to straighten it. First they corrected the inner bend of the foot.



Figure



Figure

Then they gradually lifted her foot by cutting out rings on the cast, closing the space, and holding it closed with a new strip of plaster.

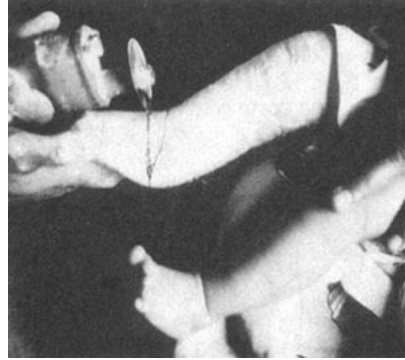

Figure



Figure



Figures

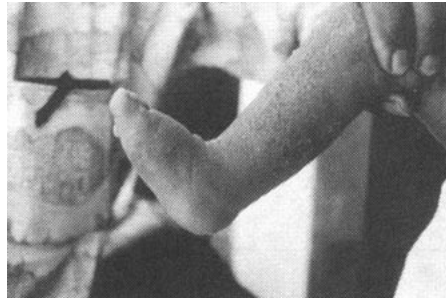

After 4 months of casting, the foot was in a good position.

IMPORTANT

After a club foot has been corrected, great care is needed to prevent it from coming back.

Both exercises and braces are essential. After strapping or casts have been removed,

continue the recommended stretching exercises twice a day.

Many children need to wear braces until they stop growing (age 13 to 18). If the problem keeps returning, surgery is probably needed.



Figure

This child who had club feet needs to use braces day and night, at least until he begins to walk, and still at night after that.

Check his feet regularly, for years, for any sign that the foot is beginning to turn in again. Improved bracing may be required.

Chapter 61: Homemade Casting Materials

Plaster bandages

Although commercial plaster bandages work best, they are very expensive. You can make homemade plaster bandages for as little as one tenth the cost. Or some of the disabled children can learn to make them. You will need:

- **plaster of Paris. If possible, a high-quality type such as dental plaster of Paris. Keep it in a tightly closed moisture-proof container.**

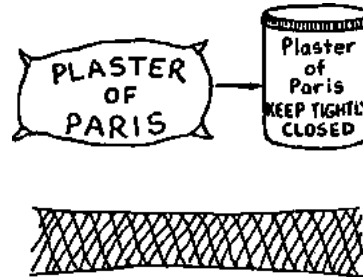

Figure

- **gauze cloth or crinoline. Crinoline, which is a high-quality open mesh cloth, works best. Good quality gauze can also be used. Holes should be about 8 to 10 per cm. (20 per inch). Cheesecloth also works, but not as well.**

HOW TO PREPARE:

- **If you use gauze or cheesecloth, first dip it into a weak solution of laundry starch and let it dry. This helps the bandage keep its shape.**

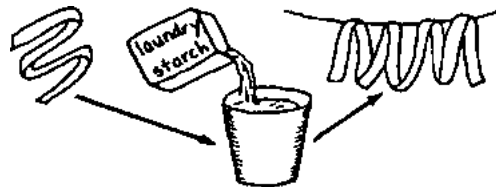

Figure

- **Cut the cloth into strips of the width you want.**



Figure

- **Rub plaster powder into the cloth and roll or fold it loosely. Do not roll it tightly or the inner part will not get wet when dipped for use.**

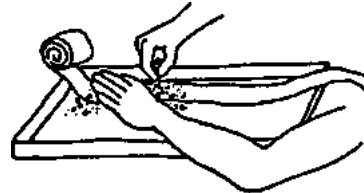

Figure

The most common problem is that the gauze does not hold enough of the plaster powder. Even if you put on a lot, some powder always falls out. The test is when you apply the wet bandage. As you rub each layer into the next, the threads of cloth should disappear into the smooth, wet, plaster surface. If not, there is not enough plaster and it will not set hard.

Suggestion: Have some dry plaster powder ready when you are casting. If needed, sprinkle a little powder over each layer of bandage and rub it smooth with wet hands. Add more to the final layer and rub it in to form a polished surface.

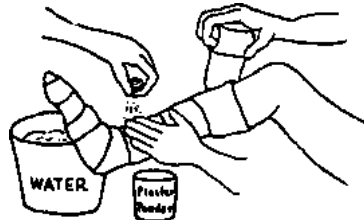

Figure

Storage: Wrap the plaster bandages in old newspaper or plastic bags and store in an airtight container. Do not prepare too many at a time. They can absorb moisture and spoil.

CAUTION: When wetting for use, up to a third of the plaster may be lost in the water. To reduce loss, put bandage gently into water and then let it drip. If you squeeze it, hold the ends of the roll and gently squeeze toward the center.

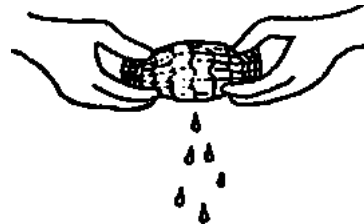

Figure

Homemade plaster takes longer to get hard than commercial fast-setting' plaster. To speed up hardening, heat the water or add a little salt to it.

Casts made of wax

To prepare a mold of a leg for making plastic braces, the first (hollow) cast can be made of

wax instead of plaster. Use either candle wax (paraffin) or beeswax. Wax can be much cheaper than plaster bandage, especially if the wax is re-used. To make a wax cast:

1 Melt the wax in a can placed in hot water

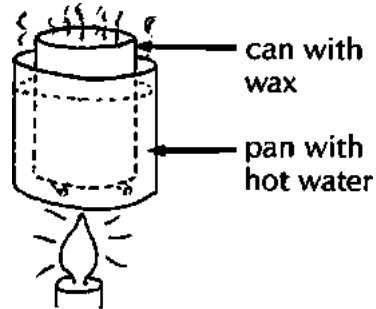

Figure

2 Cut several strips of soft absorbent cloth



Figure

3 Soak the cloth in hot wax

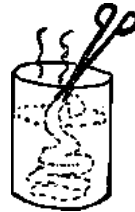

Figure

4 When it has cooled enough not to burn wrap the waxed cloths around the foot

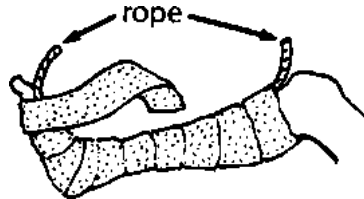

Figure

Note: Before putting on the wax you can cover the foot with stockinette. Also place a rope or strip of plastic along the top of the leg to make cutting the cast easier.

5 While the wax is still warm and soft rub and press it against the leg



Figure

6 Hold the foot in the desired position until the wax hardens (To speed hardening you can put the foot in cold water)

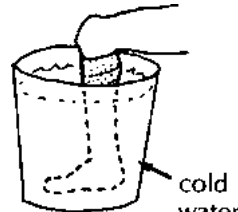

Figure

7 Cut the wet cast along the rope and carefully remove it. Go on with the other steps as described.

Re-using the wax: After the positive plaster mold has been made from the wax cast, the wax can be re-used. Heat up the pieces of waxed cloth and use them to form a new cast. Or boil the waxed cloth in water, holding the cloth under the surface with rocks or metal. The hot wax will rise to the surface. When it cools, lift it off and re-use it.

OTHER POSSIBLE MATERIALS FOR CASTING OR MOLDING

Many materials can be used for casts. Most have the disadvantage that they take a long time to harden. Possibilities include

1 Papier mch. Very slow hardening. Careful use of a heat lamp or 'hairdryer' speeds drying

2 Traditional cast materials. For example

- **In Mexico, the juices of certain plants, boiled into a thick syrup and soaked into a cloth, will harden into a cast (see *Where There Is No Doctor*)**
- **In India, traditional bone setters make casts using cloth covered with egg white mixed with flour**

3 Flour made from cassava (manioc) is also used in India to make casts

To make the solid (positive) mold of a limb, 'building plaster' works well (Wax cannot be used because it melts when hot plastic is placed over it) Clay also works, but takes several days to dry

Chapter 62: Developmental Aids

In this chapter we look at the design details of aids for lying, sitting, standing, balance, use of hands, and communication. Aids for walking are in Chapter 63

Whether or not a particular child needs an aid, and what kind of aid she needs, must always be carefully and repeatedly evaluated. An aid that helps a child at one level of development may actually hold her back at another. When considering aids, we suggest you first read the chapters on child development, those covering the particular *disability* of the child, and Chapter 56

Note. Many developmental aids have already been shown in PART 1 of this book especially in Chapter 9 (cerebral palsy), and in Section C on child development. Aids and equipment for play and exercise are in PART 2 Chapter 46 (Playgrounds) Wheelboards and wheelchairs are in Chapters 64, 65 and 66.

Lying aids

Lying face down is a good position for a child to begin to develop control of the head, shoulders, arms, and hands, and also to stretch *muscles* in the hips, knees, and shoulders. However, some children have difficulty in this position. For example

CP



Figure

Rosa cannot lift her shoulders. She has to bend her neck far back to lift her head



Figure

Juan does not have enough control and balance to reach out his arms



Figure

A firm pillow under the chest may help both these children to lift their heads better and to reach out

A 'wedge' or slanting support is often helpful. The height depends on the needs of the particular child



Letting feet hang down helps prevent



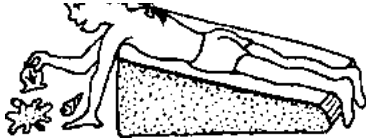

Figure

Diana manages best on a wedge high enough so that she can lift herself up a little at arms length (Height is the length from wrist to armpit)



Figure

Cassio does better on a lower Carmen and others with little or no wedge so he can lift up on his arm or hand control do best when elbows (Height is slightly less their arms can dangle. She can see than length from elbow to armpit) them moving when she moves her shoulders



Figure

Wedges can be made with:



Figure



Figure



Figure

stiff foam plastic or layers of cardboard a log and a board with a soft foam cover a stick frame

CP

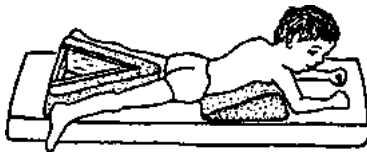

Figure

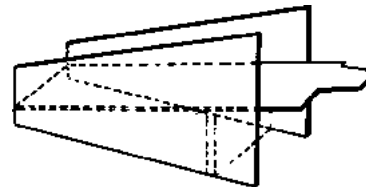

Figure

If necessary, a leg separator can be added.

Or sides can be included for the child who needs to be *positioned* with supports or cushions.

Design from *Functional Aids for the Multiply Handicapped*.

Some children are able to control their shoulders, arms, and hands better when lying on one side.

CP

A side-lying frame may be helpful for some children with severe cerebral palsy. Try cushions or padded blocks of different shapes until you find what works best. Use straps only if clearly needed to keep a good position.

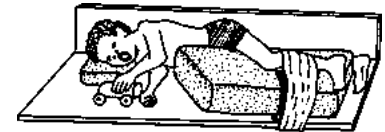

Figure

Also see lying frames for straightening hip flexion contractures and lying frames with wheels.

ADJUSTABLE BEDS

This design from the Centre for the Rehabilitation of the Paralysed in Bangladesh adjusts easily from an upper position to a lower position.

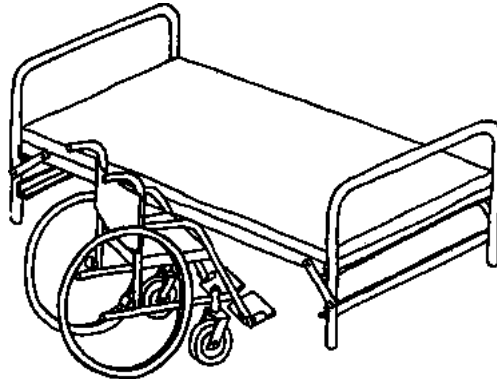

The upper position is right for moving to and from a regular wheelchair.

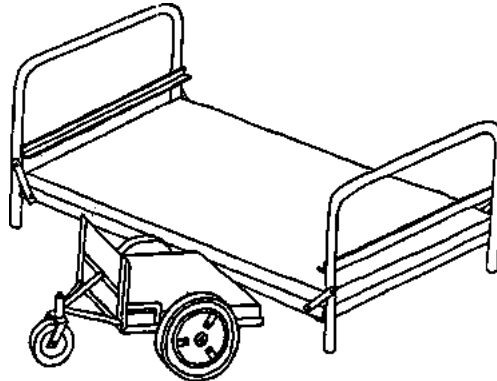

The lower position is right for moving to and from a low-level wheelchair or 'trolley', which many people use in their houses in Bangladesh.

These metal beds and wheelchairs are welded together by paraplegic workers.

ADJUSTABLE BACK SUPPORT CLAMP

Supporting a severely *paralyzed* person so he lies on his side can be difficult. Pillows easily move or slip. This simple clamp helps solve the problem. It was designed and made by disabled workers at the Centre for the Rehabilitation of the Paralyzed, Dacca, Bangladesh.

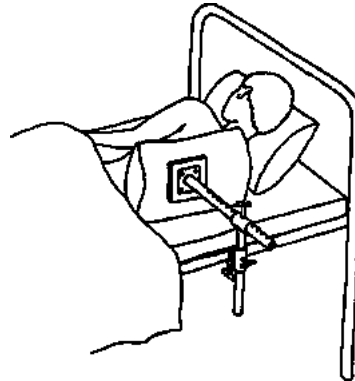

Figure

CAUTION: To prevent pressure sores, be sure the child changes position often (see Chapter 24).

Sitting Aids

CP

A wide variety of early sitting aids are included in the chapter on cerebral palsy. Special seating *adaptations* for chairs and wheelchairs are in Chapter 65. Here we include a few

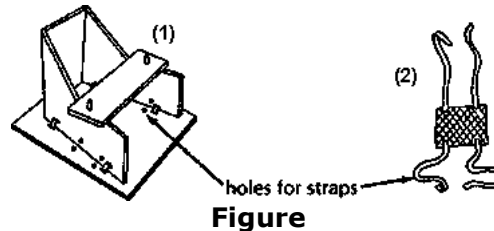
more ideas:

(1) seat for child with spasticity who has knock-knee contractures (one of many possibilities)

(2) strap for keeping legs apart (one around each leg and tied through holes in sides of seat)

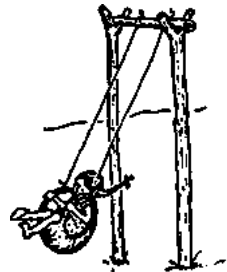

Tire seat or swing bends head, body, and shoulders forward to help control spasticity

A log or roll seat helps the child with spasticity or poor balance sit more securely with legs spread. Log should be as high as the knees. Leave a little room between the cut-out circle in the table and the child's belly

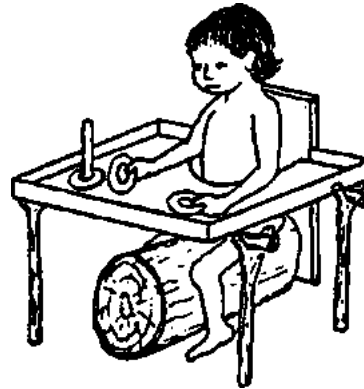

Figure

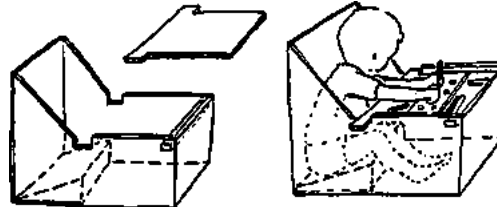

seat for a child with spasticity whose body stiffens backward

Design from *Handling the Young Cerebral Palsied Child at Home.*

OTHER IDEAS FOR HOLDING LEGS APART from Don Caston and AHRTAG



A seat and table like this. In the form of a fish on the ocean makes sitting in a special seat fun. So do the village-made toys (PROJIMO, seat design by Don Caston).



The seat can be used for straight leg sitting, or put on top of the table for bent-knee sitting. Other designs include 'squirrel' seats on 'tree' tables.

from other parts of this book

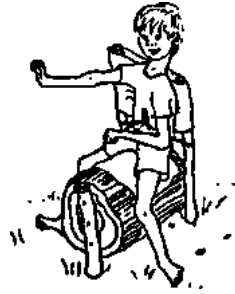

Figure

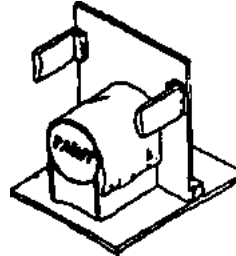

Figure

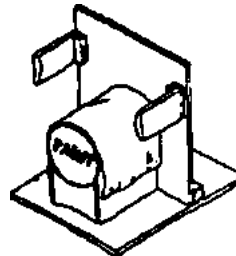

Figure

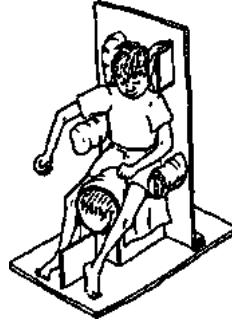

Figure

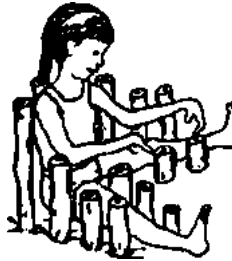

Figure



Figure



Figure



Figure



Figure



Figure

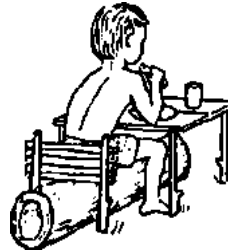

Figure

For more ideas on adapted seating, see Chapters 9, 35, and 65. Also, see scooters and walkers with roll seats.

Standing aids



Many children who have problems with balance or control for standing may benefit from standing or playing in a 'standing aid'. Even for the child who may never stand or walk on her own, being held in a standing position with weight on her legs helps *circulation* and *bone growth and strength*.

STANDING BOARD

Sometimes a child who does not have enough control or strength to hold his head up when lying,



Figure

can hold his head up better when sitting or standing

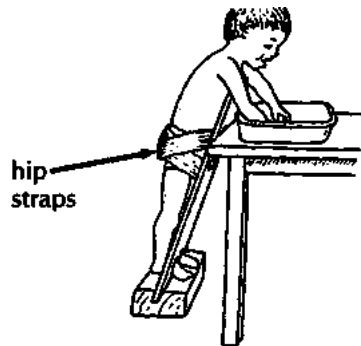

Figure

A simple standing board can help hold the child in a stable position. This one leans against a table

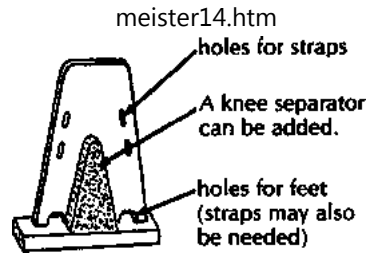

Figure

LEANING BOARD from Don Caston and AHRTAG

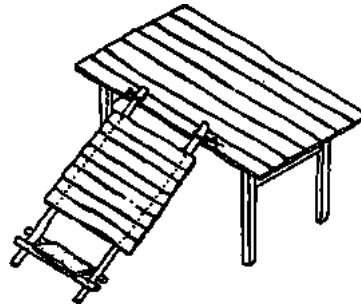

from Don Caston and AHRTAG.

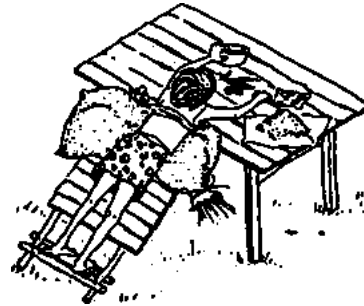

Figure

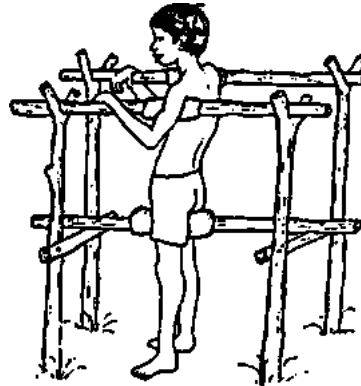

Figure

BACK-BOARD

This can be used to gradually bring a child to a standing position. It is especially useful for older children who get dizzy if stood up straight too quickly. This can happen after a spinal cord injury or a long, severe illness. The child can be stood up gradually and for longer

each day

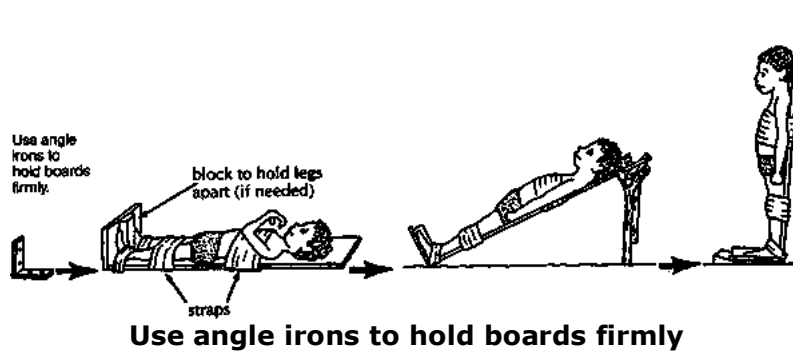

STAND-IN TABLE

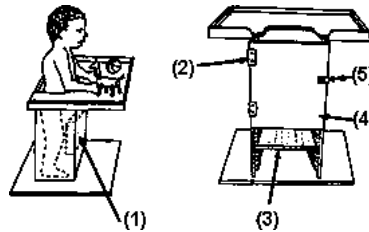

Figure

- (1) padded knee block
- (2) hinges (cloth or leather)
- (3) adjustable foot board for children of different heights
- (4) door
- (5) clasp

OTHER IDEAS



large tile or cement pipe



hollow log (like people use for bee hives)

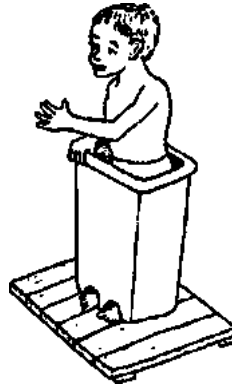

plastic garbage container (Fasten it to a wide base to keep it from tipping over.)

STANDING FRAMES

These are mainly for a child with contractures or painful joints who has difficulty standing straight. The child can gradually be straightened up.

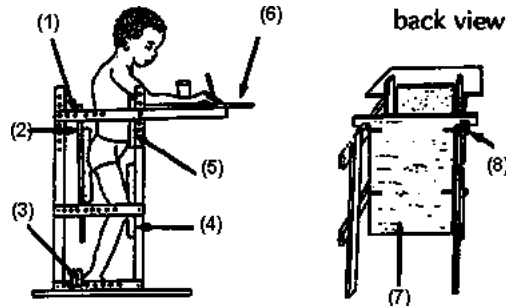

ADJUSTABLE MODEL

- (1) bolt or pin for adjustment**
- (2) adjustable padded hip support**
- (3) adjustable padded ankle foot support**
- (4) knee pad**
- (5) chest pad**
- (6) table**
- (7) Remove backboard to stand child in frame**
- (8) bolts or pins for adjustment**

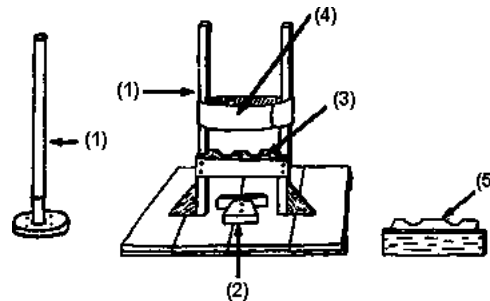

MOVABLE MODEL

- (1) Uprights can be made of wood or metal tubing.**
- (2) adjustable foot support**
- (3) adjustable board with padded notches for knees**
- (4) wide belt of thick cloth with *Velcro* or strap adjustment**



SIMPLE FIXED MODEL

For some children, a chest belt will also be needed.

STANDING-AND-WALKING FRAME

This is a useful aid to begin standing and walking, for children paralyzed or severely affected below the waist (paraplegia, spina bifida, diplegic cerebral palsy).

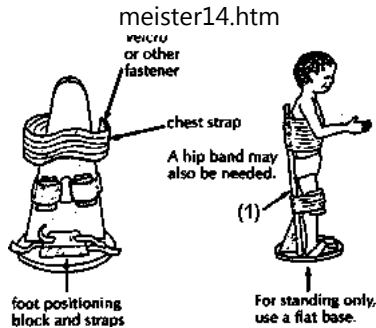

Figure

The back-board should tilt back slightly to let the child stand straight up (1).

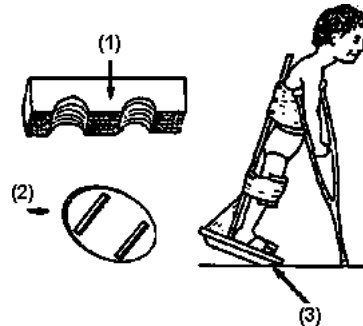

Figure

Instead of kneepads, you can hold the knees better using a firm knee support molded from stiff-foam plastic or many layers of cardboard glued together (1).

The base is oval (2) with the longer dimension sideways.

For walking, add runners with a curved front (3). This makes it easier for the child to tilt forward and lift off.

STANDING-WALKING BRACE

This has the same use as the standing-walking frame above, but is especially useful for children who need to learn how to walk before they are fitted for braces with a hip band or body brace.

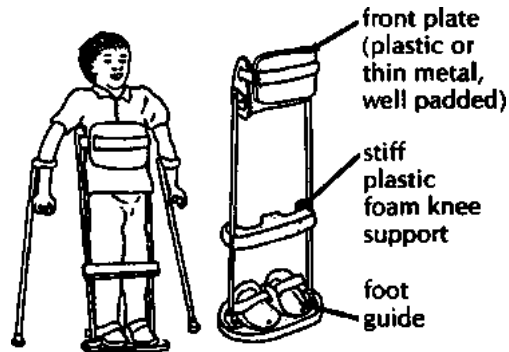

DESIGN THAT DOES NOT ALLOW SITTING

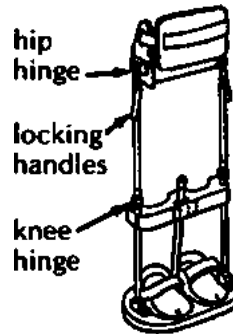

DESIGN WITH HIP AND KNEE HINGES TO ALLOW SITTING

(From *Physically Handicapped Children - A Medical Atlas For Teachers.*)

Aids for balancing and body control



Activities for improving balance are discussed. Here we bring together a few of the aids for balancing that are shown in different parts of this book, together with a few new ones.

BALANCE BOARDS



An old drum or barrel makes a good 'roll' for exercise and positioning.

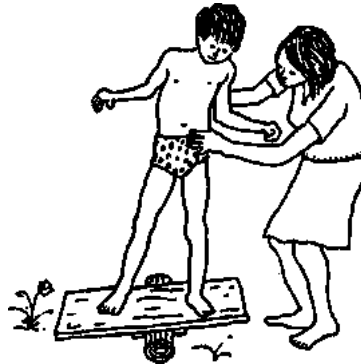

A balance board like this rocks less smoothly because the center rocker is so narrow.



A wider rocker works better.



An upright stick can be used at first to help her keep her balance

BALANCE BEAMS

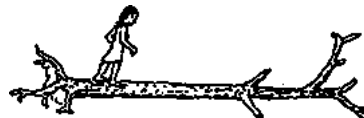

fallen tree



logs

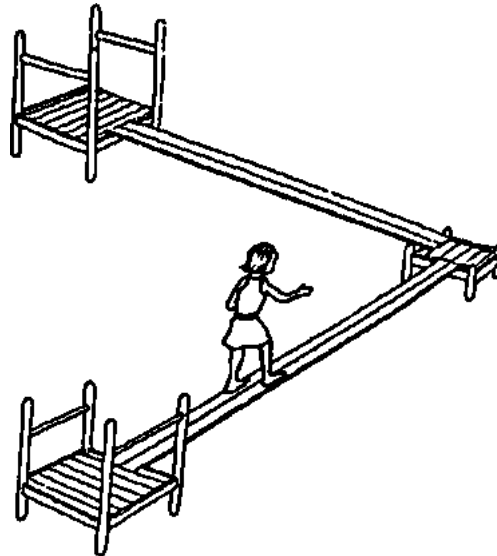

Figure

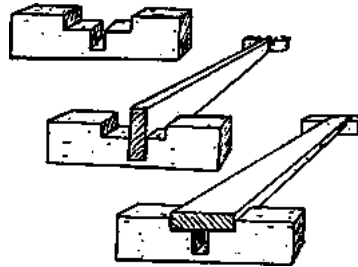

adjustable wide or narrow balance beam

Design from *UPKARAN Manual*.



For the child whose ankles bend in,

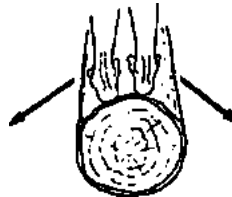

walking on a log helps bend the ankles outward

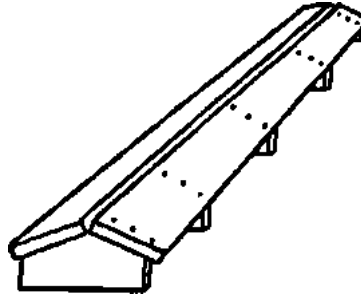

Or the child can walk on slanting boards, like this



For the child whose ankles bend outward,



walking on boards like this helps bend the ankles inward

To improve balance also see swings, rocking horses and merry-go-rounds.

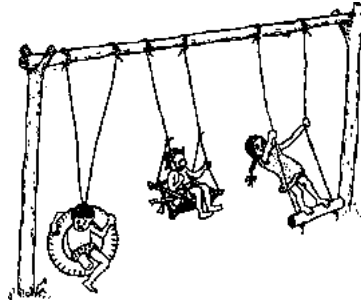

Figure

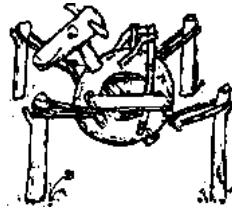

Figure



Figure

Other aids

Many aids not yet described in PART 3 have been described in other parts of this book. Here is a brief summary of some of these to give you basic ideas and tell you where to look. We also give a few ideas of aids not shown before.



EATING AND DRINKING AIDS



TOILETING AIDS



key holder



wash cloth mitten
for washing dishes
(or self)



button
fastener



aids for working with feet

HOLDING AND REACHING AIDS

SPIRAL HOLDING AID



Cut a piece of heavy rubber tube like this



Bolt it to a piece of plastic pipe or bamboo.



Use it like this.

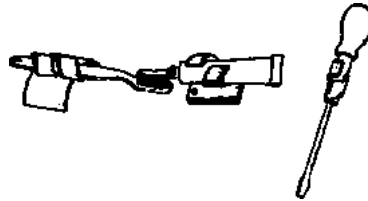

spiral attached to washstand

Note: For larger objects such as a knife or ruler, the spiral can be made of garden hose.

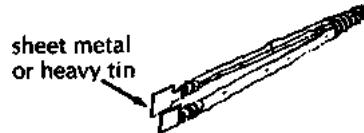

REACHING TOOL

From Don Caston and Joan Thompson.

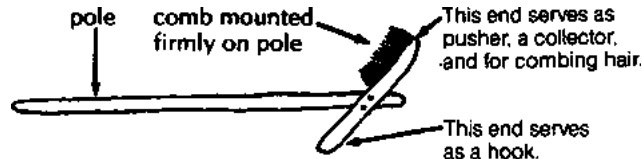

ALL-PURPOSE TOOL

WRITING AIDS



pencil in a large gum eraser



loop of car inner tube

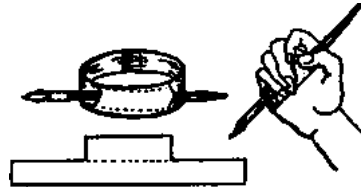

leather or thick cloth



Velcro



bamboo or tube or hose



rubber or plastic tubing

COMMUNICATION AIDS



page turner

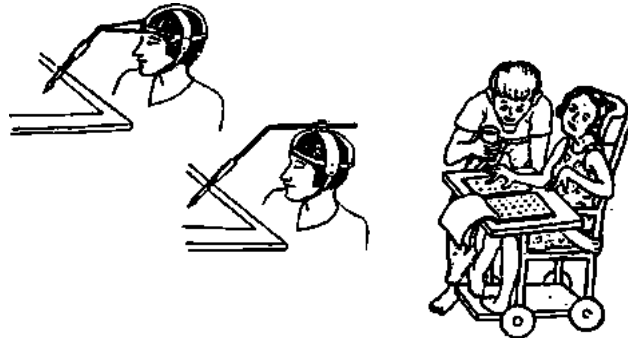

aids for painting, writing, or pointing

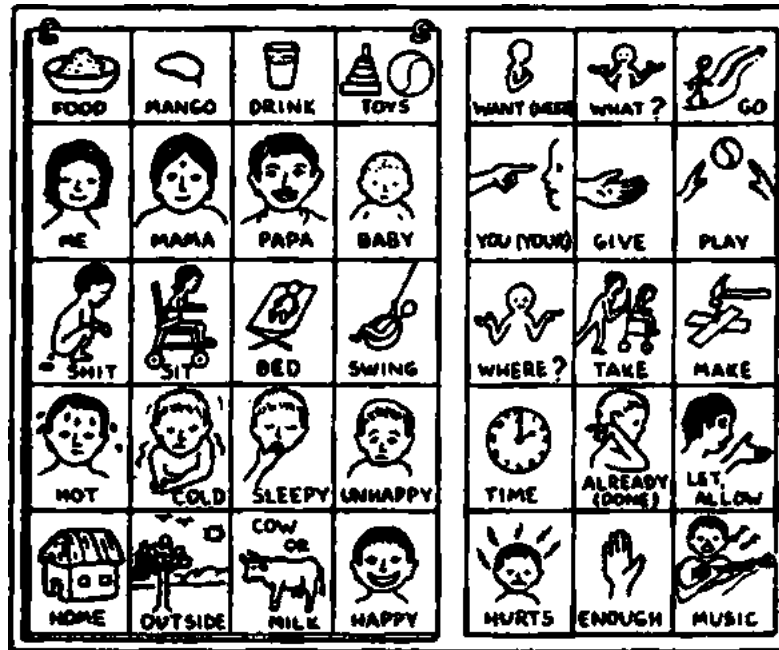

communication board

From Art and Disabilities.

PHYSICAL EXAMINATION, MEASURING AND RECORDING AIDS

INSTRUMENT FOR LEVELING HIPS

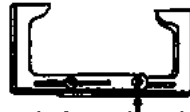
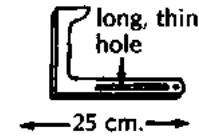

nut, bolt, and washer

Cut 2 pieces of thin plywood like this. Fasten them together so that they slide back and forth.



To use, close instrument around child's waist and push down against hip bones. Then raise or lower shorter leg until the instrument is level

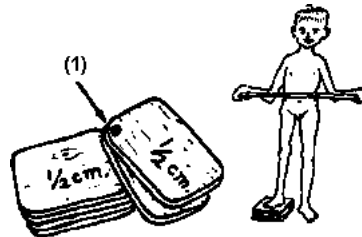

aid for measuring leg length difference

(1) Cut rectangles of 1/4 inch thick boards and bolt them loosely together at one corner.

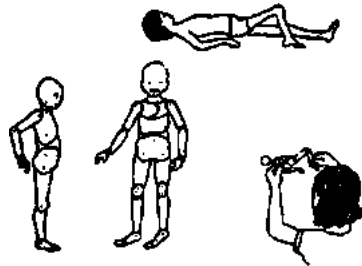

'flexikins' for measuring contractures and deformities

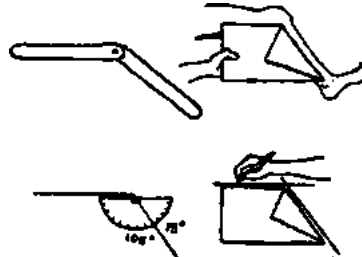

other methods for measuring contractures



rib-hump angle measurer



aids for hearing examination

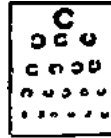

aids for seeing examination

FOOT CONTRACTURE PREVENTION AIDS



Figure

Also see Chapter 59, "Correcting Joint Contractures," and Chapter 58, "Braces."

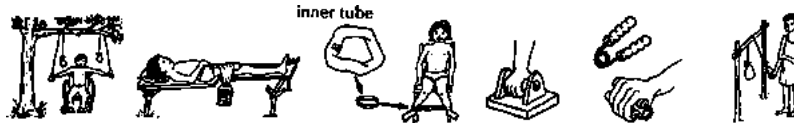
EXERCISE AIDS**Figure****Figure****Chapter 63: Walking Aids**

In designing aids for a child, we need to think not only about her type and amount of *disability*, but also the stage of progress she is at. For learning to walk, she may progress through a series of stages and aids. Here is an example:

1. Parallel bars

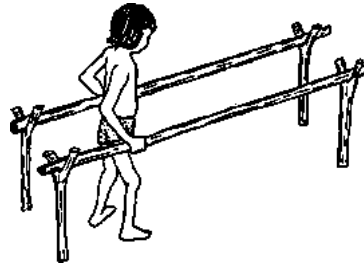
**Figure**

2. Wheeled walker





Figure

3. Crutches modified to form walker

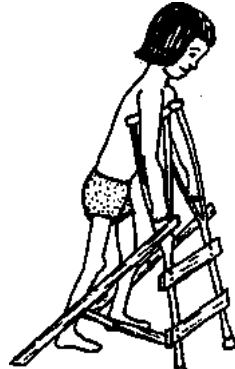

Figure

4. Underarm crutches



5. Below elbow crutches

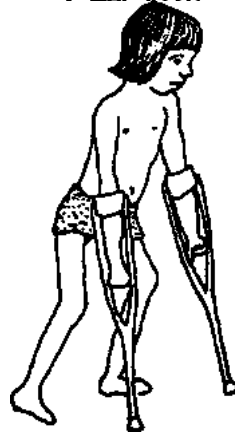

Figure

6. Cane with wide base



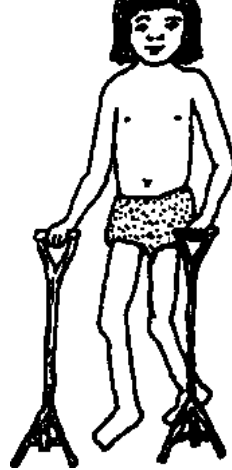

Figure

7. Walking stick (cane)



8. If possible, no aids at all



Figure

In this chapter we show a variety of aids for walking. Most can be made easily out of tree branches or wood. Some can be made from building construction bars (reinforcing rod) or metal tubing, and may require welding.

We include these ideas not to ask you to copy them, but with the hope that they will 'trigger' your imagination. Take ideas from these designs, and use the materials you have at hand. When possible, make your aids to meet the needs of the individual child.

At a village *rehabilitation center*, it helps to have a wide selection of aids on hand, so that you can try different ones on a particular child to find out what works and what she likes best.

Parallel bars

Simple designs for outdoor parallel bars, both adjustable and non-adjustable, are included in Chapter 46 on playgrounds. We also give suggestions for adjusting the bar height to meet the needs of the individual child. The designs shown are:

OUTDOOR BARS

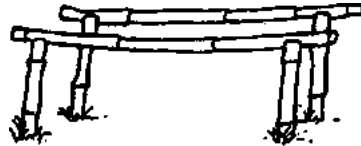

simple, non-adjustable bars (bamboo, wood, or metal)



bars with a leg separator for a child whose knees pull together

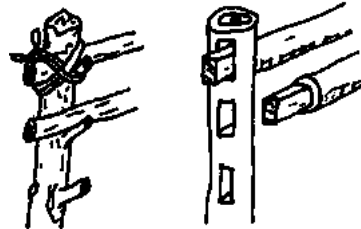

2 designs for bars with adjustable height

INDOOR BARS (design details for two of several models)

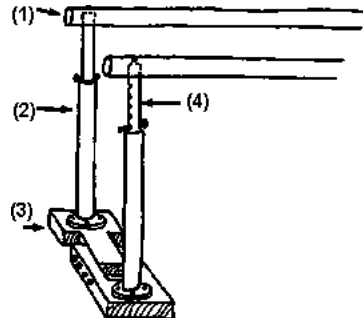

ADJUSTABLE MODEL

- (1) wood or metal pole**
- (2) metal pipe (or try bamboo)**
- (3) Adjust width by sliding the 2 blocks of wood in and out, then bolting.**
- (4) tube metal or wood pole.**

Adjust height by putting bolts through different holes.

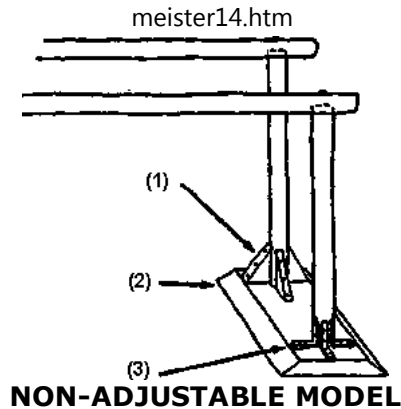

NON-ADJUSTABLE MODEL

- (1) triangular wood supports (best if bolted)**
- (2) slanted edge to help prevent tripping**
- (3) angle irons**

IRON PIPE BARS

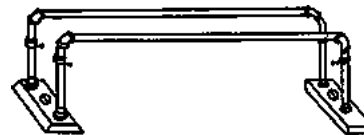

NON-ADJUSTABLE BARS



WITH FOOT DIVIDER

Design from *Functional Aids for the Multiply Handicapped.*

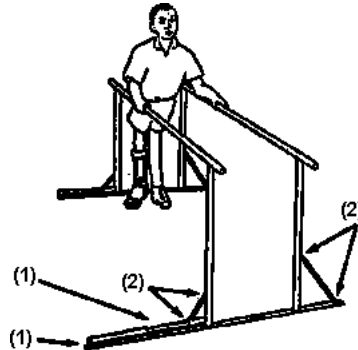

METAL CONDUIT TUBING - ADJUSTABLE WIDTH BARS

- (1) This pipe slides in and out of this one.**
- (2) welds**

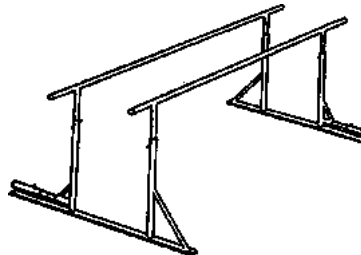

ADJUSTABLE WIDTH AND HEIGHT

Designs from *Poliomyelitis, Huckstep.*

Walkers

There are many ways to make walkers or walking frames. Here we show a range from very simple to more complex. Choose the design and height depending on the child's needs and size.

Julio has strong arms and good body control. He can use a simple low walker



Figure

Lico has weak elbows and poor balance or body control. He needs a higher walker with armrests



Figure

Anna has weak legs and poor balance. She does best with underarm crutches built into the walker

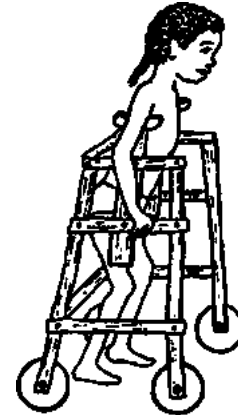

Figure

The above walkers can be made with 2 cm × 4 cm boards (such as those used on roofs to hold tiles), or thin trees or branches. The wood or plywood wheels roll easily when little weight is on them (when child pushes walker) but have a braking action when child puts full weight on them (when taking a step).



Figure

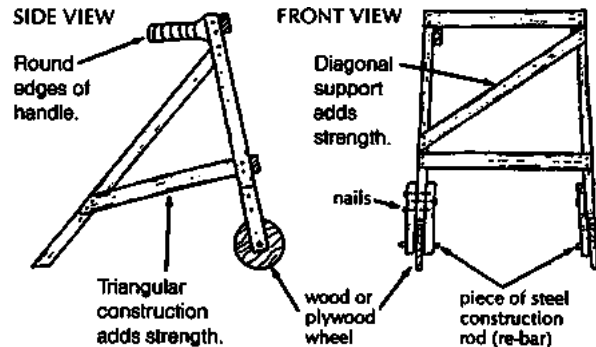

Figure

Finding the design that works best for a particular child often involves experimenting and changing different features.

For example, Carlota has poor body and hip control and tends to fall through the space between her arms when the handgrips are upright

A higher walker with a bar as the handgrip works better for her



Figure



Figure

These walkers can be made out of welded or bolted metal tubing



This walker with slanting bars lets a child hold it at the height that he finds works best
Other walker designs

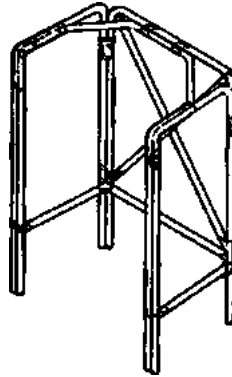

WALKER MADE FROM CANE, RATTAN, OR BAMBOO

Design from *Rattan and Bamboo Equipment For Handicapped Children*, J. K. Hutt.

Joints can be tied with cane, ribbon, nylon string, strips of car inner tube or whatever.



WOOD WALKER

Design by Don Caston.

Wood walker for a child whose legs need to be held apart.

Note: A walker with no wheels is very stable but harder to move.

A walker with 2 wheels and 2 posts is fairly stable but easy to move.

A walker with 3 or 4 wheels is very easy to move but can easily roll out from under the child (unless the child is seated).



Figure



Figure

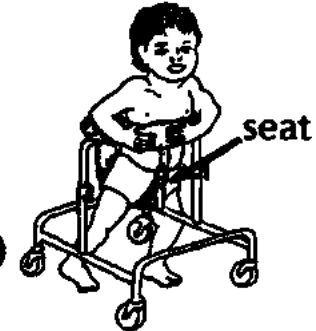
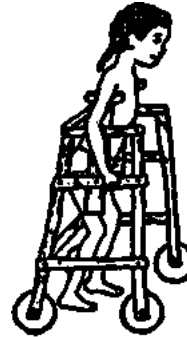

Figure

WALKER MADE FROM SOLID IRON ROD (RE-BAR) WITH ARMRESTS-WELDING REQUIRED

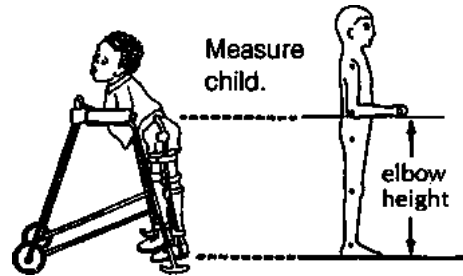

Figure

Design from *Simple Orthopaedic Aids*, Chris Dartnell.

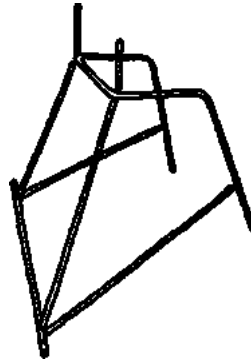

Cut and bend rod.

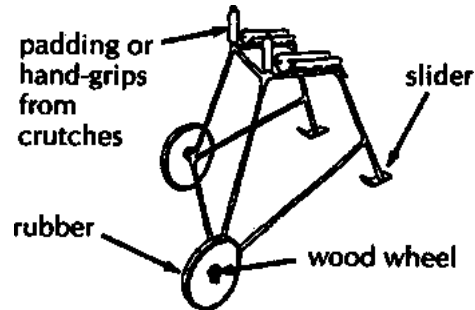

Assemble walker.

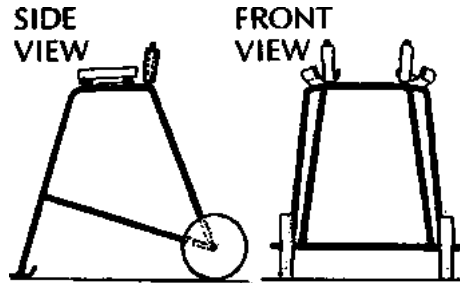

Figure

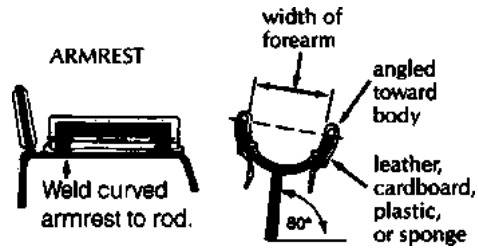

Figure

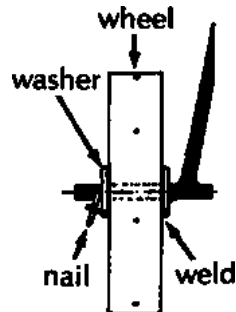

Figure

SIMPLE WALKER MADE FROM SOLID IRON ROD (RE-BAR)-WELDING REQUIRED

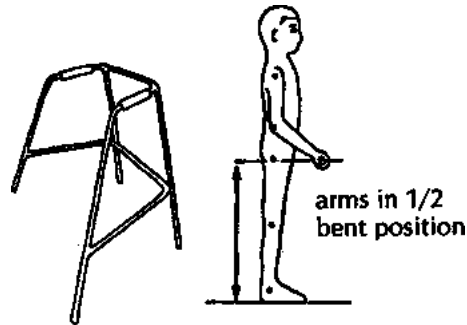

Figure

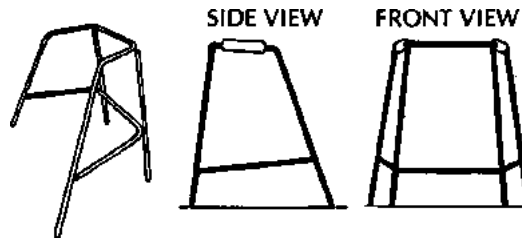

Cut and weld rod.

Design from *Simple Orthopaedic Aids*, Chris Dartnell.

CART WALKERS

The added weight in the cart can help the child stand firmly - and makes learning to walk

more fun.

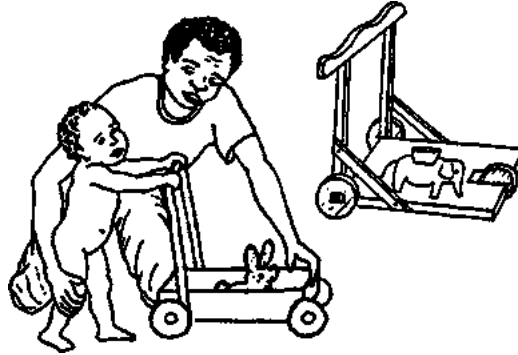

Figure

As the child progresses, he can change his grip from the front bar to the side bars.

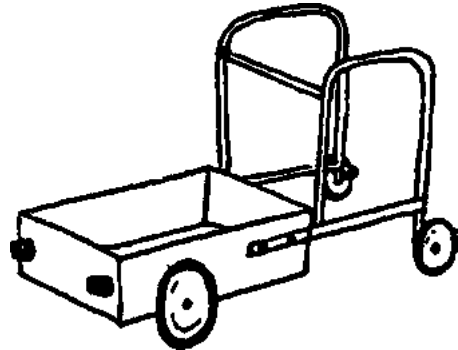

Figure

Design from *Handling the Young Cerebral Palsied Child at Home*, Finnie.

CP

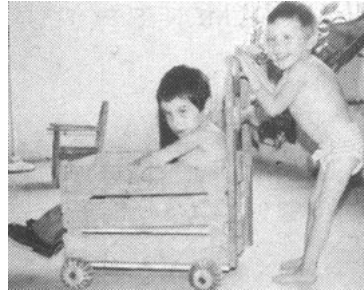

Wheels on this cart walker are made from the round seed pods of a tree in Mexico, called Hava de San Ignacio.

ROLLER SEAT AND TRICYCLE WALKERS



Figure

Useful for a child with cerebral palsy who 'bunny hops' (crawls pulling both legs forward)

together). Seat holds legs apart. The 'chimney' helps child keep his arms up and apart.

Design from *Handling the Young Cerebral Palsied Child at Home*, Finnie.

CP

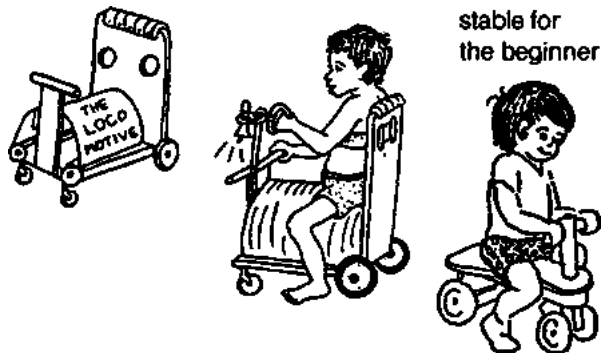

Figure

WALKERS FOR SITTING AND STANDING

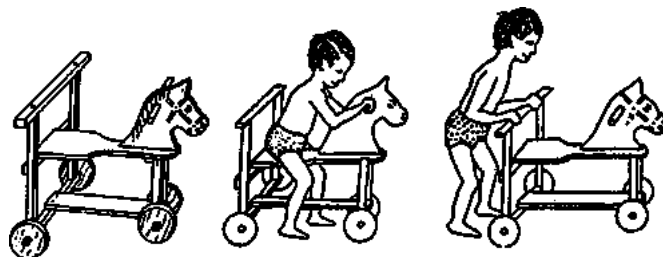

Figure

SPIDER WALKER

CP

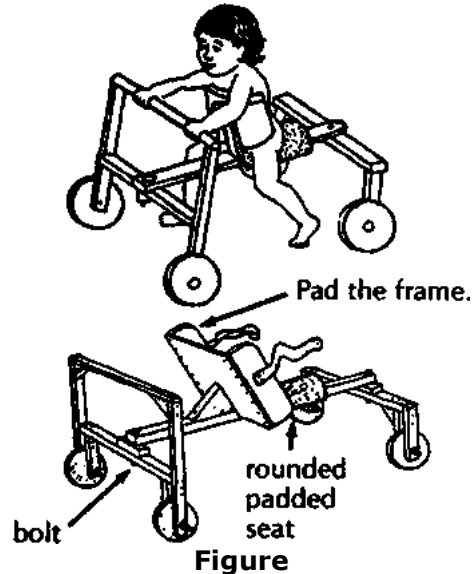

Useful for the small child severely affected by cerebral palsy.

SADDLE-TYPE WALKER

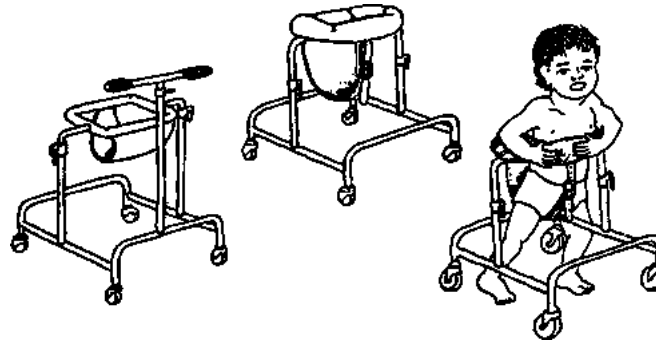

Figure

Design from *UPKARAN Manual*.

CAUTION: Sitting walkers should usually be used, if at all, as an early and temporary step toward walking. With them, the child does not learn to balance well and the hips are often at an angle which can form *contractures* (see Chapter 8).

Crutches

MEASUREMENTS FOR UNDERARM CRUTCH

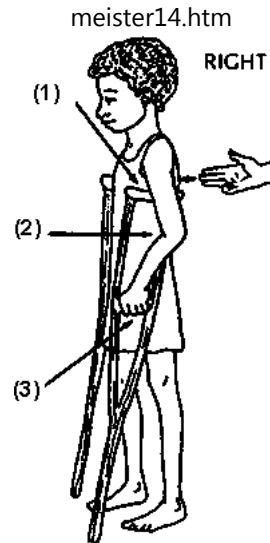

Figure

Top of crutch should be 3 fingers' width below armpit (1) so it does not press under the arms.

Elbow should be bent a little (2) so that arms can lift body when walking.

Handgrip (3) should be placed for comfort - usually about 1/3 of the way down crutch.



wrist drop from crutch pressure

WRONG



Figure

WARNING: Bearing weight under the arms like this (4) can cause nerve damage that in time can lead to numbness and even paralysis of the hands.

Teach the child to put weight on her hands, not on her armpits.

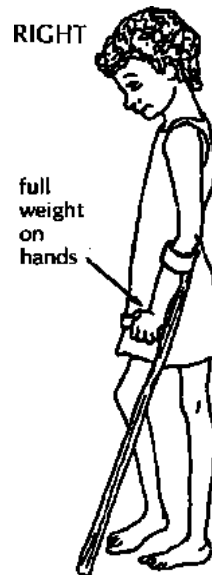

Figure

One good way to make sure the child does not hang on the crutches with her armpits is to use elbow crutches like this.

There are many designs for underarm crutches. Here we show a few.

CRUTCHES FROM TREE BRANCHES, padded with wild kapok

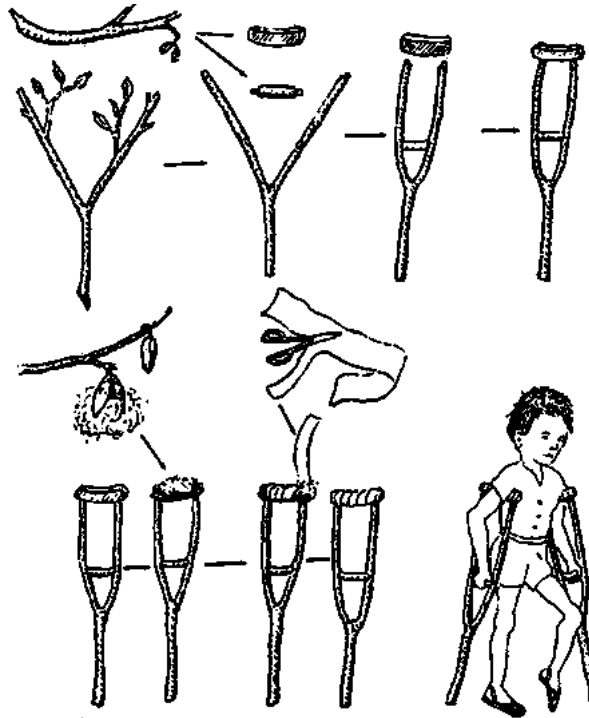

Figure

These single support designs using tree branches are not as strong as the double support design shown at left.

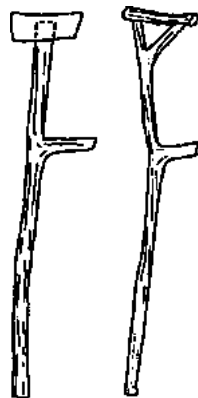

Figure

WOODEN CRUTCHES

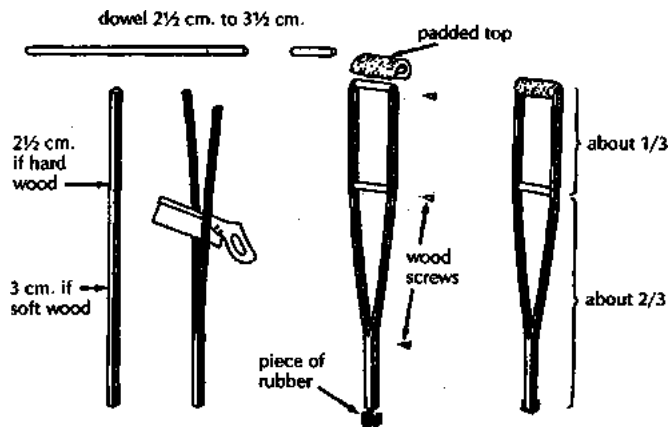

Figure

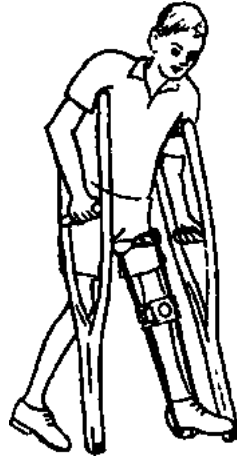

Figure

Design from Poliomyelitis, Huckstep.

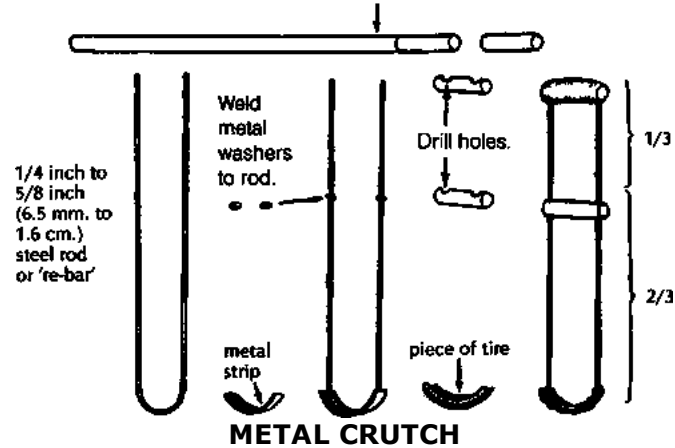

Figure

From Poliomyelitis, Huckstep.

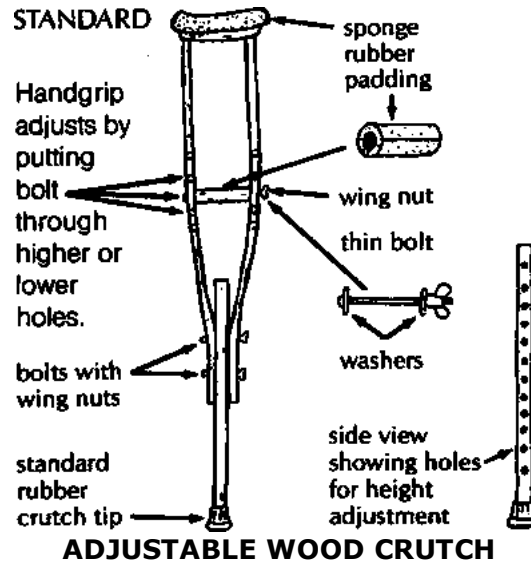

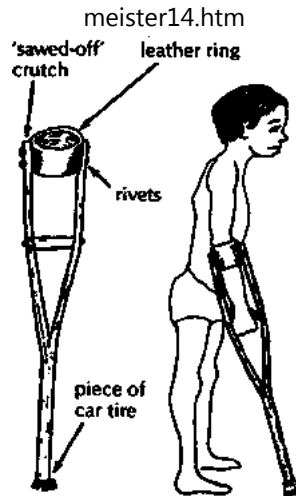

LEATHER RING ELBOW CRUTCH

These crutches are easy to make and work well for children who have strong arms and hands.

A disadvantage is that if a child falls he may have trouble getting his arms out quickly.

OTHER ELBOW CRUTCHES

With these open elbow-ring crutches, the child can easily get his arms out if he falls.

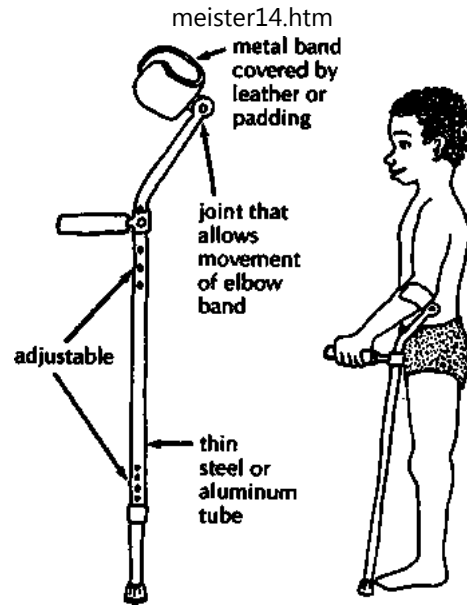

STANDARD ADJUSTABLE

USING LOCAL RESOURCES

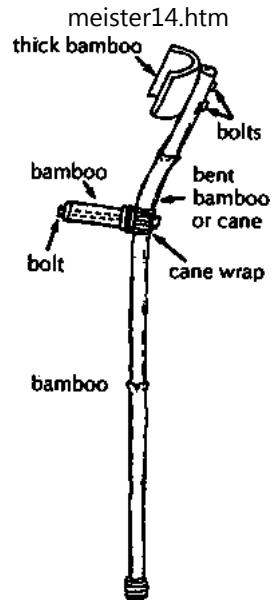

Figure

Design from Philippines.

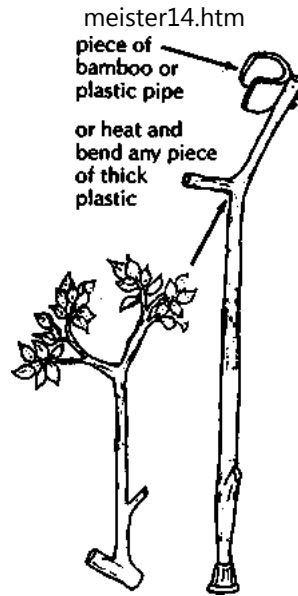

Figure

Design from PROJIMO

Gutter crutch ('arthritis crutch') For children who, due to elbow pain or stiffness, cannot use straight-arm crutches.

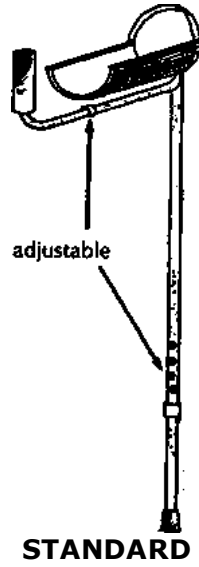

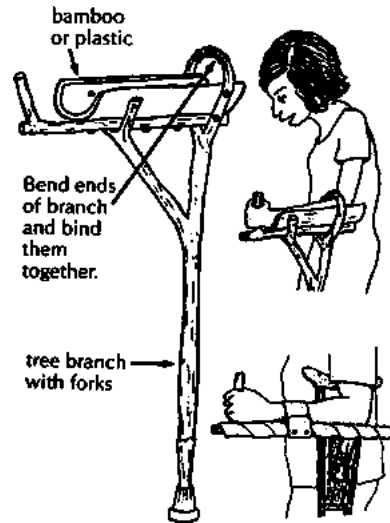

USING LOCAL RESOURCES

Crutch for a child with weak elbow-straightening muscles.

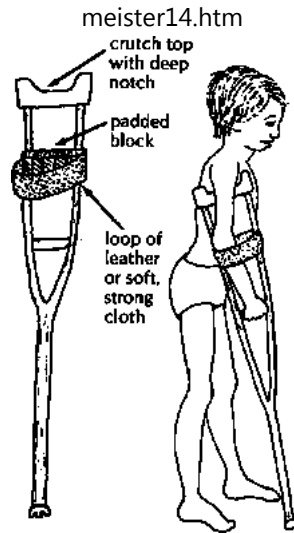

Figure

These are only examples. Once you get the idea, you can invent your own. A lot of experimentation is often needed to adapt crutches for children with severe arthritis.

Canes and walking sticks

Straight poles can help a child with balance problems

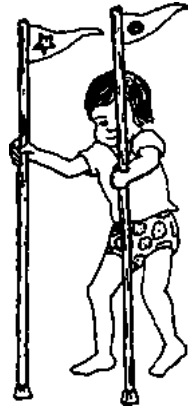

Figure

Canes. Simple canes provide some balance and support but the child has to use the walking muscles in both legs



Figure

CAUTION: Use poles that are taller than child so if she falls they will not poke her eyes.

For the child who needs to strengthen a weak or painful leg, a cane makes him use his leg. A crutch lets him avoid using his leg so the muscles that bend his leg get stronger, rather than the ones that straighten it

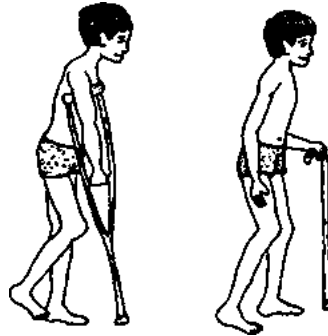

Figure

CANES CUT FROM FOREST PLANTS

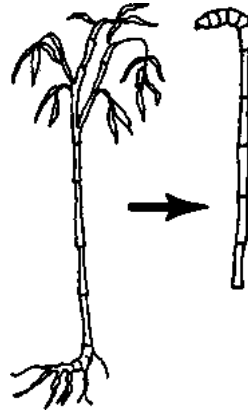

Figure

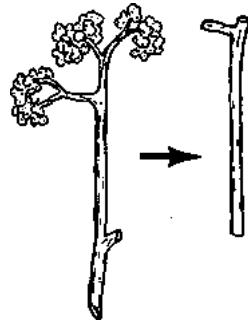

Figure

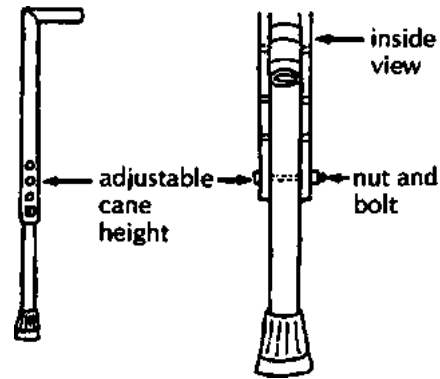

ADJUSTABLE METAL TUBE CANE

3 OR 4 FOOTED CANE-FOR GREATER STABILITY

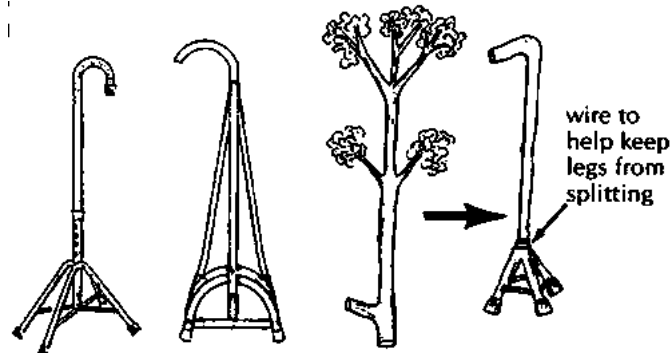

STANDARD METAL TUBE

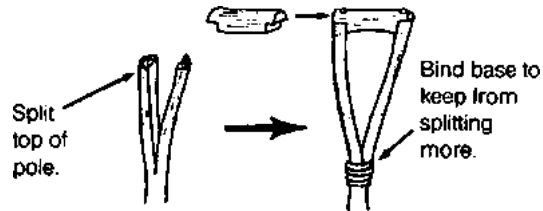

ALTERNATIVE HANDGRIP

Rubber tip made from car tire for metal tube or bamboo crutch or cane

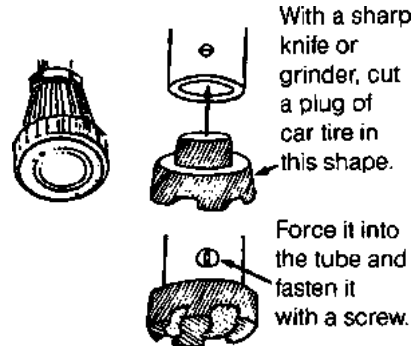

STANDARD CRUTCH AND CANE TIP

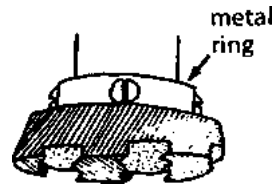

Figure

For walking in sandy places make crutch and cane tips extra wide.

Adaptations of walking aids for carrying things and for work

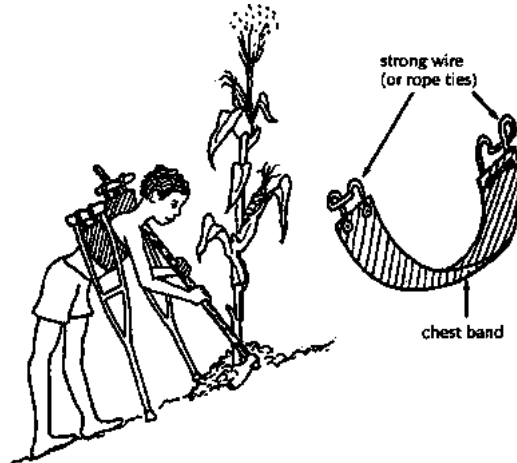

CRUTCH SLING to free hands for work



LEATHER OR CLOTH POUCH

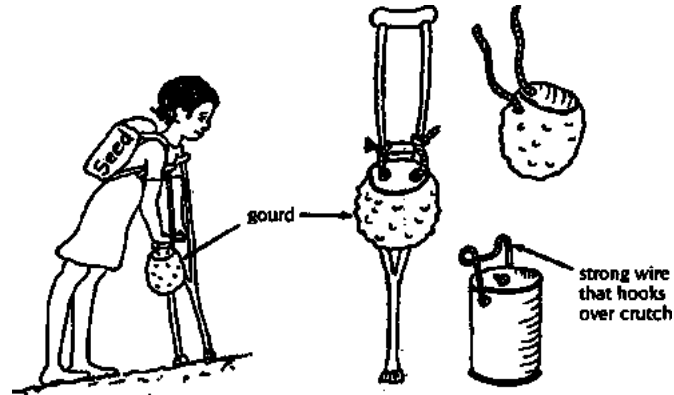

BACKPACK

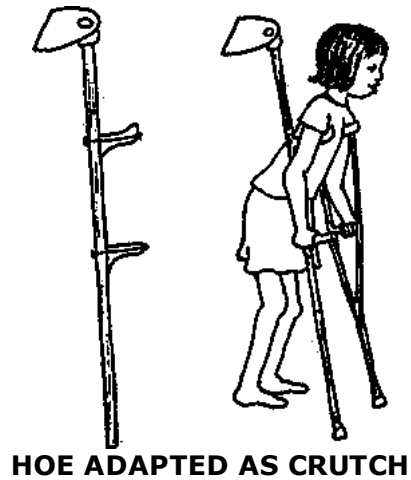

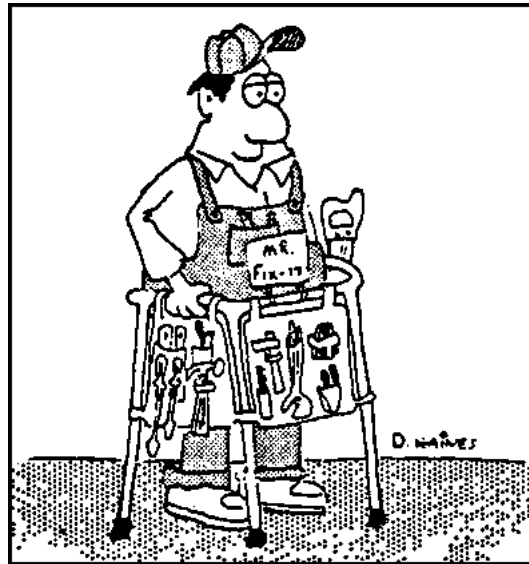

Reprinted from Accent on Living, 1984

Chapter 64: Decisions about Special Seats and Wheelchairs

In this chapter we look at the things you will need to consider when buying or building a special seat or wheelchair, to best meet the needs of a child. *Adaptations* of seats and wheelchairs for special *positioning* needs are discussed in Chapter 65. Designs for building 6 basic wheelchairs are in Chapter 66.

Meeting the needs of the individual child, family, and community

Most children who need a wheelchair or special seat have severe weakness in parts of their bodies, or *muscles* that pull them into awkward or deforming positions. Seating

should, as much as possible, keep these children in healthy and useful positions. It must provide support, but also allow them enough freedom to move, explore, and develop greater control of their bodies. For example:

CP

1. A child who is 'floppy' and slow to develop ability to sit,
2. may at first need a seat with straps and supports to hold her up.



Figure



Figure

3. As she develops better head control and then body control, the supports can be removed little by little,

4. until finally-if possible-she is able to sit anywhere, with little or no special supports. Now low back support is all she needs.



Figure

CAUTION: If a child needs to be supported as much as the one in the second picture, **do not keep her strapped in her seat for long.** She also needs periods of free movement and exercise to

develop more independent head and body control. Keeping her strapped in for too long, or providing too much support after she has begun to gain more control, may actually slow down her progress. **Seating needs to be changed and supports reduced as the child develops.**

Also, children who do not feel in their *butts* need frequent position changes and 'lifting', and special cushions.

Special seats and wheelchairs need to be adapted not only to the individual child, but also to the particular family, local customs, and community situation. For example:

A 'high chair' lets the child join the family that eats at a table.



Figure

A 'low chair' lets the child fit in where the family eats at ground level.



Figure

Also, a 'high' wheelchair may be helpful where cooking and other activities are done high up.



Figure

But a low 'wheelboard' or 'trolley' may be better where cooking and other activities are done at ground level.



Figure

It is also important to consider the type of ground surface on which a wheelchair will be used.

Where land is flat and fairly smooth, and entrance into houses is level, a chair with a small wheel at the rear may work well and be less costly to make.



Figure

But where there are curbs, steps, rocks, or other obstacles, a chair with small wheels at the front works better.

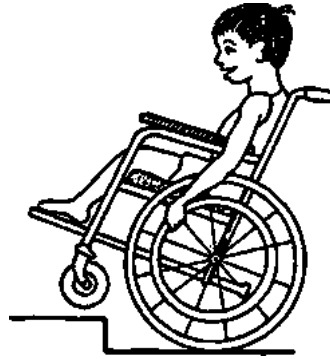

Figure

Narrow back tires and small front wheels allow for faster travel on hard smooth roads but are useless on rough, sandy roads.

To jump over obstacles, the child can learn to do a 'wheely' (tilt the chair back with the front wheels in the air).

On rough, sandy surfaces wide back tires and relatively large, wide front casters make moving about much easier.



Figure

Wide tires, like the wide feet of a camel, help in sandy places.

Having the right wheelchair for the local situation frees the child to move about more easily in the community.

Healthy, comfortable, and functional positions

Whether or not a chair has wheels, the position in which it allows a child to sit is very important. (See Chapter 65.)

For most children, the chair should help them to sit more or less like this:

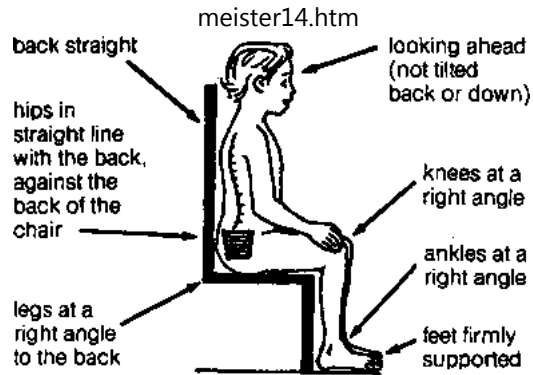

Figure

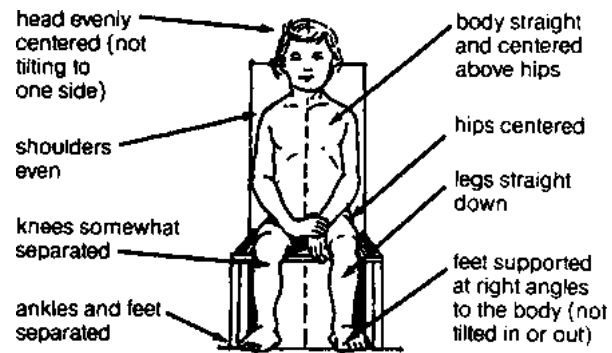

Figure

CAUTION: The seat should be wide enough to allow some free movement and narrow enough to give needed support (see Measurements).

Common seating problems and possible solutions

Problem: Hips tilt back

CP

In children with spastic cerebral palsy the hips often stiffen backward. This triggers spasms that straighten the legs and cause other muscle tightness with loss of control.

**Figure**

Also, children with weak hips or back, from *spinal cord* injury, spina bifida, or severe polio, often sit slumped with their hips tilted back and the back severely curved. This can lead to permanent deformity.

One of the most common causes of backward tilting hips is a chair like this one that is too big for the child.



Figure

Other causes of backward tilt and bad position are:

a chair back that tilts far back

and a cloth back that sags.



Figure

These let the child lean back and cause the hips to slip forward.

Also, footrests that are far forward so that knees do not bend enough can increase *spasticity* that tilts hips back.

A good position can often be gained through:

a fairly stiff, upright back at a right angle to the seat,

a chair that fits the child so that his hips reach the chair back,

the knees at right angles, and feet firmly supported.



Figure



Figure

Most children, and especially a child who tends to fall forward in his seat, will sit better and more comfortably if the whole chair tilts back a little. But be sure to keep right angles at hips, knees, and ankles.

To tilt the chair back, the rear wheel mount can be moved higher **up**. You may also need to move the wheel mount **back** farther to keep the chair from falling backward with going uphill. Be si re the front caster barrel is still straight up or making turns will be harder.

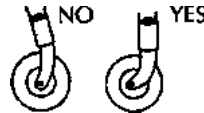

Figure

Keeping cost down and quality up

For many families, a wheelchair can be a great or even impossible expense. There are many ways to keep costs down. But be careful. Some low-cost choices may make the chair too clumsy weak, or unsafe. Other low-cost choices may actually increase the chair's usefulness and life. For example, a very useful, long-lasting wheelchair can be made of wood - or from a cheap wooden chair. Even wheels made of wood (if made well) may work well and last a long time. But, making the hubs or bearings of wood usually leads to trouble. Standard wheelchair wheel bearings are very expensive. However, you can often get strong, high-quality used metal bearings free or very cheap at electrical appliance repair shops or auto repair shops.

Factory-made or homemade wheelchairs?

Often you can save money by making your own wheelchair or by asking a local craftsman to make one. Also, a homemade chair design can be more easily adapted to

your child's particular needs.

On the next pages we give information that may help you decide about different wheelchairs and effective low-cost ways to make them.

You can make a fairly effective low-cost wheelchair by attaching bicycle wheels or wooden wheels to an ordinary wooden chair. Also, it is easier to attach special aids or supports to a wooden chair than to a metal chair. This design is adapted from AHRTAG's booklet, "Personal Transport for Disabled People".

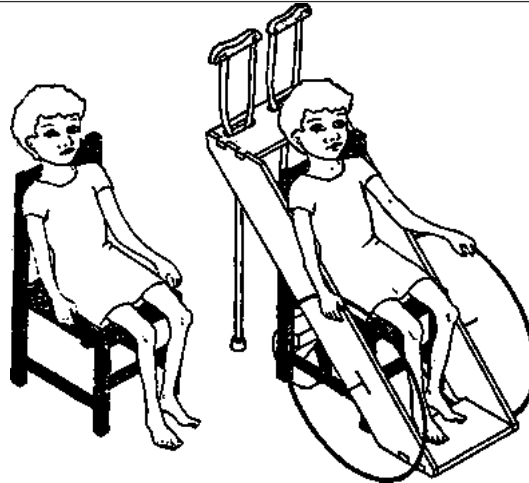

Figure

Any wheelchair is better than none-but sometimes not much better. Look for low-cost alternatives that make a chair better - not worse.

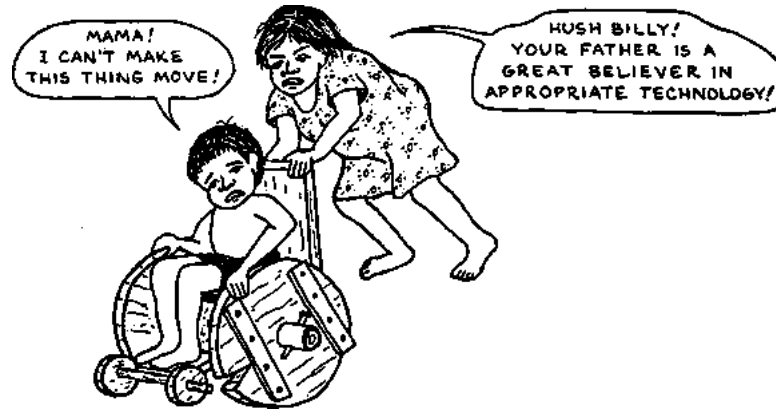

Figure

REMEMBER: A wheelchair needs to satisfy the rider - not just the maker. Before (and after) buying or making a chair, think carefully about the different features that will help it best meet the needs of the particular child and family.

When buying or making a wheelchair (or any other aids), consider:

- **Cost.** Keep cost low but quality high enough to meet the child's needs.





Figure

- **How long will the chair last? The longer the better, unless it is only for temporary use.**
- **How easy and quick is it to make? The easier and quicker the better, as long as it meets your needs.**
- **Availability of materials. Make use of local low-cost, good-quality resources (local wood, cheap metal, used bearings, bike parts, etc.).**
- **What tools and skills are needed to make it? If welding equipment or skills are not locally available, a wooden chair may be a more practical choice.**
- **How easy will it be to adjust or repair? Wood chairs that are bolted together are often the easiest to adjust or add special supports to.**
- **Weight. The lighter the better, while making sure it is strong enough.**
- **Strength. Heavier persons need stronger chairs and stronger axles. (A small child's chair may be supported by a bicycle axle attached on one side only. A bigger child needs the axle to be supported on both sides, or a stronger axle.)**
- **Width and length. The narrower and shorter the better while meeting the child's needs (but not so short that it tips over easily).**
- **How easily can it be moved-by the child sitting in it or by someone behind? How easily can it be tilted back to go over rough spots? Lifted up stairs? Transported? (Does it need to fold to take up less space?)**
- **How well is it adapted to the particular child's wants and needs? Is it comfortable? Does it allow the child to sit in a healthy position?**

- **Fit and growth factor.** How well does it fit the child now? How long will it continue to fit her? Can it be adjusted to fit her as she grows?
- **How well is it adapted to living situations, the home, local customs, width of doorways, surface of floors and roads, curbs and other barriers?**
- **Appearance.** Is the chair attractive? Does the child take pride in it? Do other children want to ride it?

In considering choices for the design, building materials, and special features of a wheelchair, be sure to carefully consider the above questions.

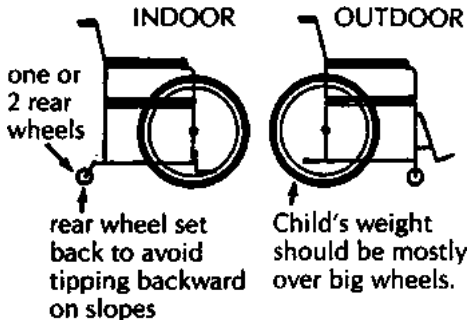
Design choices for wheelchairs

FEATURE	DESIGN DETAILS	ADVANTAGES
<p>WHEEL SIZE AND POSITION</p> <p>2 big wheels with 1 or 2 small caster wheels</p>  <p>INDOOR</p> <p>OUTDOOR</p> <p>one or 2 rear wheels</p> <p>rear wheel set back to avoid tipping backward on slopes</p> <p>Child's weight should be mostly over big wheels.</p>	<ul style="list-style-type: none"> • Large wheels let rider push herself. • Small caster wheels allow easy turns (on cement, not sand). • For leg amputees, rear wheels must be moved back to prevent tipping over backward 	<ul style="list-style-type: none"> • Child can move it herself if she has hand and arm control. • Large wheels go over rough surfaces easier.

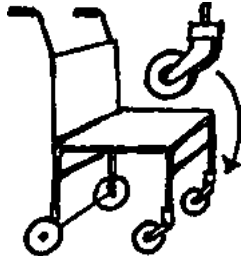
Figure**Figure****4 small wheels****casters for easier turning**

Very simple temporary chairs can be made by putting 4 wheels on an ordinary wood chair.

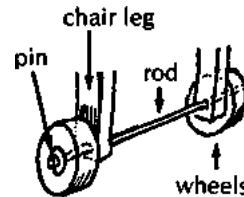
**Figure**

- good only on smooth floors for a child who cannot push or help push his own chair

- cheaper

- takes up less space

- easier to move child in and out of

3 big wheels

- You can use 3 bicycle wheels.

- Some models have removable front wheel so that chair can be easily changed to have small front wheels for use inside the home.

- excellent for long distance and rough road travel

- can be used by a person with strength in one hand only

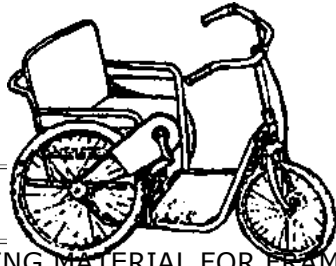

**BUILDING MATERIAL FOR FRAME
hand crank and steering
steel tube**

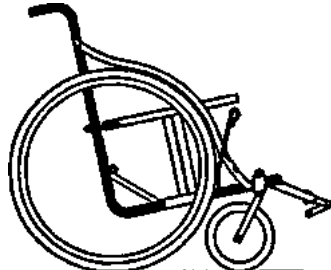

Whirlwind wheelchair



AHRTAG design

- Thin-walled electrical conduit tubing can be used - 5/8 inch to 1 inch diameter.

Some riders have 2 chairs for travel, and a smaller one for home use.

A strong, long-lasting, fairly light chair can be made better and cheaper than most commercial chairs.

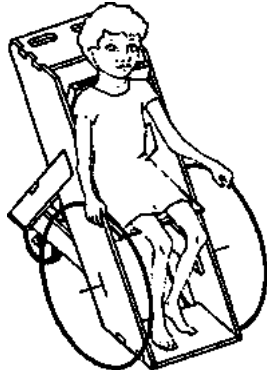
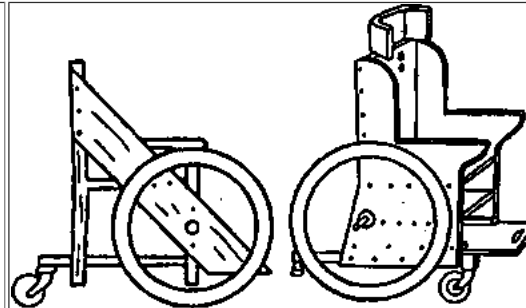
Wood**AHRTAG model****wood chair model design**

- relatively cheap and easy to make-mostly wood, few or no welds
- easy to adapt and to add special supports or tray tables

Re-bar (metal reinforcing rod used to strengthen cement)

Design can be the same as for metal tube chairs but it is easier to adapt because the re-bar is easy to bend

- relatively cheap
- easier to bend and weld than steel tubing

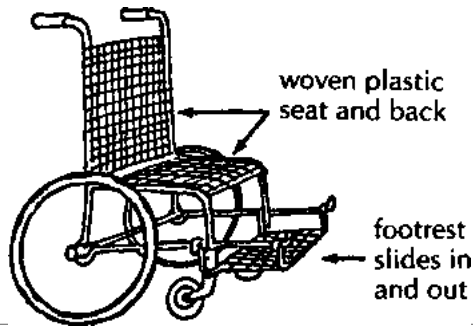

- can have plastic woven seat and back (easy to clean)
- especially good for small chairs

PVC pipe (plastic water pipe)

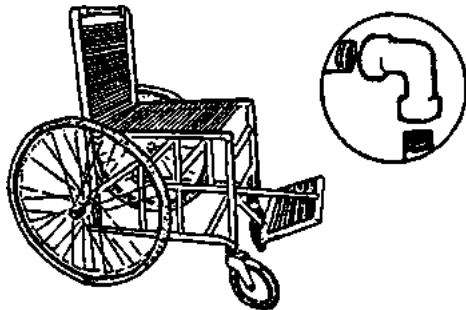

Figure

- Use 15 mm PVC pipe
- comes with joints so that it can be fitted together with a special glue
- For details see reference.

- lightweight
- can be built mostly by glueing pieces together

SEATS AND BACKS

Soft canvas or leather stretched between supports

- For child who is likely to pee or shit in the chair use a cloth that is easy to wash
- Plastic-coated canvas makes cleaning easy but is hot and may irritate child's

- easiest seating and back design for folding wheelchairs
- Adjustment to shape of butt gives comfort

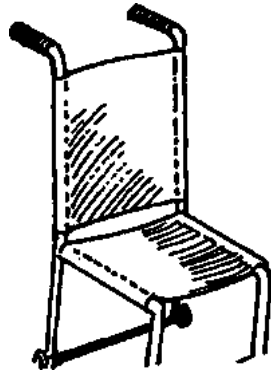

Figure

bottom. Best to use an absorbent washable pad over it

(but cushion is needed to protect against pressure sores)

- Curving back may help keep child from falling sideways

Firm (but padded) back and seat

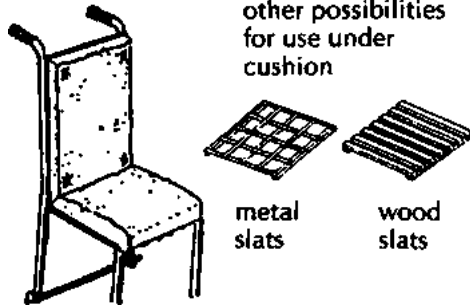

Figure

- Use wood or thin plywood
- Special designs allow a wood seat to swing up for folding



Figure

- Wood seat and back allow easy addition of supports and adaptations
- Firm wood back and seat help child sit with

back straight and knees apart (especially important for children with spasticity)

Woven seat and back

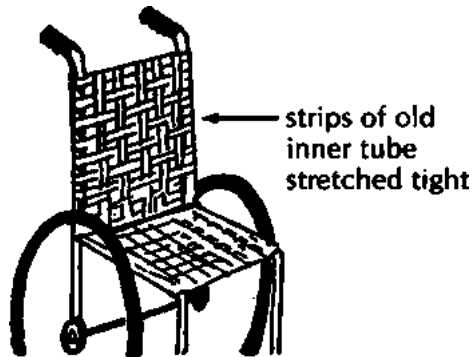

Figure

- Use natural basket fibers reeds, or rattan
- or use plastic webbing
- or use tightly stretched strips of car inner tube

- An open weave is cooler in hot weather
- Plastic or rubber woven seats can be easily washed. Can be used as a chair to bathe in

TIRES

Pump-up with air 'balloon' tires

Figure

- Bicycle tires and tubes work well for the large wheels-20 inch (51 cm) 24 inch (61 cm) or 26 inch (66 cm) **wide or narrow.**

Puncture-proof inner liners may be available

- **softer ride**
- easy to replace
- **wide** tires good for sand and rough ground
- **narrow** tires better on smooth paved roads

Solid tires (standard wheelchair wheels)

Figure

Buy from wheelchair supply center to fit diameter and width of rim

- no flat tires
- good for speed on very smooth surfaces

Rubber hose inside bicycle tire

Figure

- Overlap ends and cut at 45° angle
- Fill those into tire

- no flat tires
- softer ride than with solid tire
- cheap

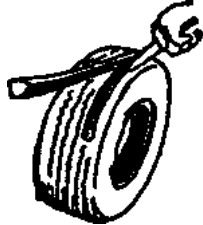
Thin strip of old car tire

Figure

- Cut strip in wedge shape to fit rim
- Wire ends together



Figure



Figure

- no cost
- long-lasting

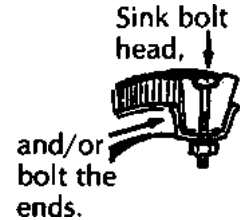

Figure

Large machinery fanbelt (discarded)

Figure

- Use old power belts or fan belts from industrial machinery or tractors. Cut to fit and wire ends together

- no cost
- long-lasting
- wedged to fit wedge rim

Piece of old bicycle or scooter tire

- used for middle-sized or small **wood wheels**
- Notch edges, glue, and nail to wheel

- cheap
- If heavy tire is used it may last a long lime
- Protects edge of wood wheel



Figure

BIG WHEELS**Standard factory-made wheelchair wheels**

Figure

Bicycle wheels (rims and spokes)

Figure

- Buy to fit chair
- available from wheelchair dealers
- 24 inch (61 cm) or 26 inch (66 cm) rims for adults
- 20 inch (51 cm) rims for small children (may be hard to find)

- little work needed (if they are bought to fit standard hubs)
- May come fitted with hand push rim

- For children, standard thickness spokes may be enough
- For large persons, heavy-duty spokes may be needed

- less costly than standard wheelchair wheels
- available in different sizes and widths

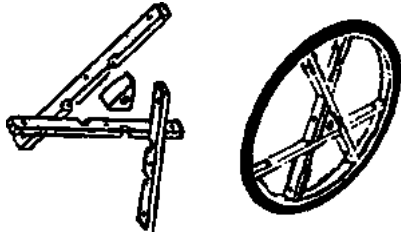
Bicycle rims with wooden spokes**Figure**

- notched wood cross-pieces on a triangular wood base can be greased and used as the hub

- no need to know how to fit spokes
- works with wood hub

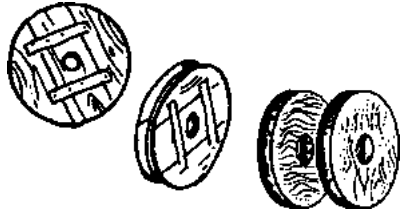
Wood wheels - big or small**Figure**

- Use boards or plywood
- To avoid splitting screw and glue 2 layers together with grain running in opposite directions
- Cut notch in rim to hold solid tire

- relatively cheap
- little skill required- mostly carpentry
- works with wood axles
- heavy-duty bearing can be added

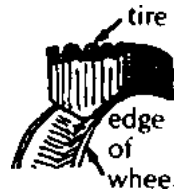
**Figure****CASTERS AND WHEELS**

(**Caster** means that the wheel can swing in different directions for making turns)

- Casters come with hard or balloon tires in many sizes weights styles and prices

- little work to attach- especially if standard mount and bearings are used

If possible, get (or make) casters with

Standard wheelchair caster wheels

ball bearings



Figure

Casters from other (non-wheelchair) equipment (used or new)

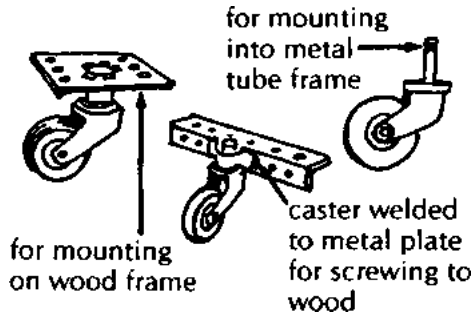

Figure

- Use 3 inch to 6 inch wheels
- larger, wider wheels for rough ground
- Be sure bearings are strong enough and in good condition
- Drill holes in rubber wheels to make them weigh less

- less costly (especially if not new)
- often full wheel and caster bearings come with them

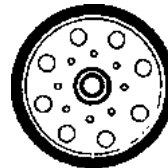

Figure

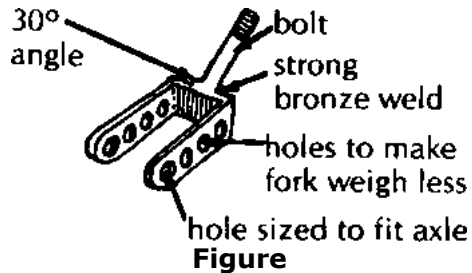
Bent and welded steel caster forks

- Choose bolt width to fit bearings
- A bent steel tube can be used instead of a metal band

- less costly than factory-made casters
- strong (if well made)

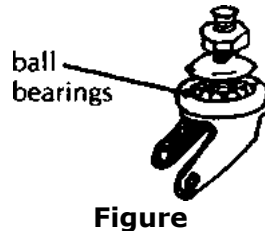
HUBS, BEARINGS, AND AXLES**Standard wheelchair bearings**

- A standard wheelchair uses 12 bearings 2 for each wheel axle and 2 for each upright caster bearing
- How a ball bearing works

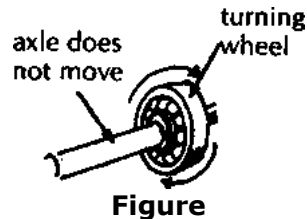

- These bearings come as part of standard wheelchair hubs and wheels
- Most factory-built wheelchairs have unusual sized axles and therefore must be fit with special wheelchair bearings

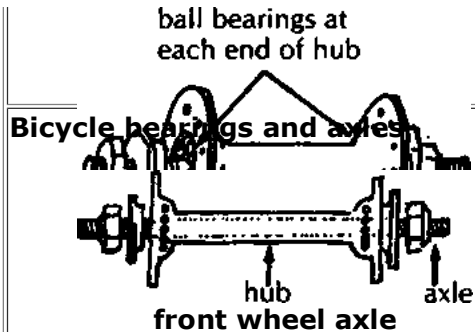

For mounting alternatives see wheelchair designs. Also see the AHRTAG Manual

- cheap-especially if old bicycles are used
- easy to get
- can be used with complete bicycle wheels

Rear bicycle wheel axle and bearings

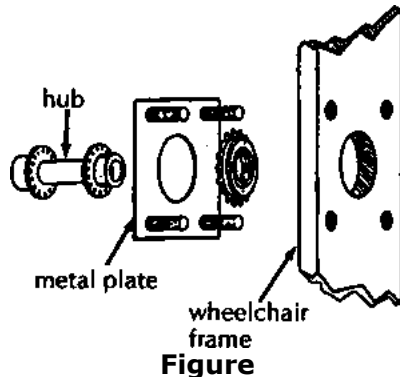

- First take free-wheel mechanism apart and remove ratchets (1)
- Then attach hub to a metal plate as shown and spot weld it.
- Other methods for one-end axle support are in the AHRTAG Manual

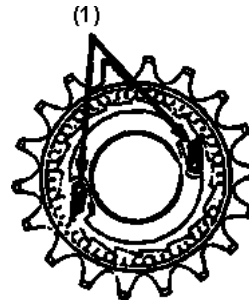

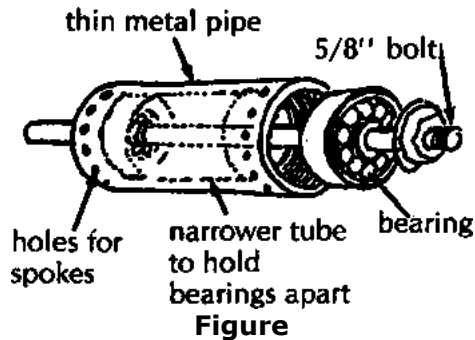
Figure**Used machinery bearings**

- Find used high-speed bearings of the size shown (or near the size). *Volkswagen* alternator bearings and certain power tool bearings work well.
- Use 5/8 inch steel bolts for axle.

- no need to adjust, grease, or clean
- usually free or vary cheap
- In wheelchairs they will last a very long time.
- If done well, results are better than with commercial hubs and bearings.

Wood bearing

- Use a hard wood that will not split.
- Soak wood in old motor oil.
- For more ideas and details on wood bearings, see AHRTAG Manual

- cheap and fairly easy to make

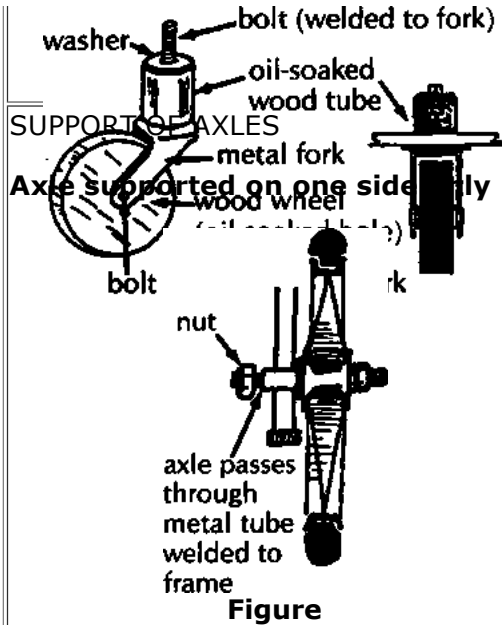

This is the standard mount for factory-built chairs.

- Strong steel axles are needed for support at one side only. Axle should be at least 5/8 inch thick for a large person.
- For a very small child bicycle axles can be supported by one side only. One way is to weld bicycle axles to a thin metal pipe. (1)

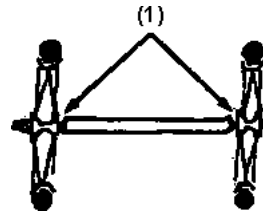

Figure

- Not as wide or heavy as the chair with 2-side support.
- easier for user to get a full-length push with hands and arms
- narrow size important for doorways and transporting

Pass pipe through a wood frame,

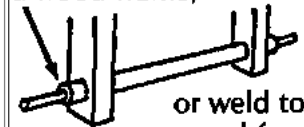

or weld to metal frame.
Figure

Axle supported on both sides

This can be done in several ways:

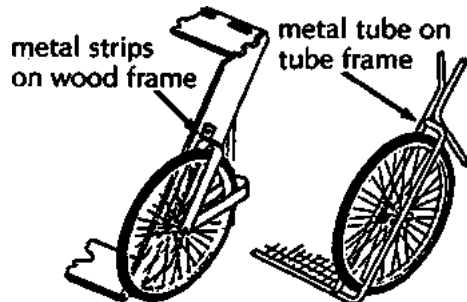

Figure

- Place outer bar of axle support so that it allows as much room for hand pushing by the rider as possible.

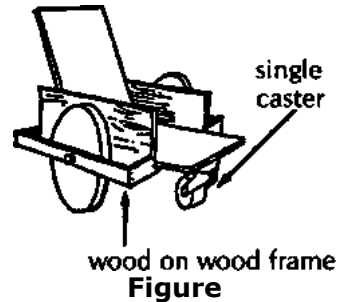

Figure

- 2-sided support allows use of standard bicycle wheels and axles.

- easy to build and replace

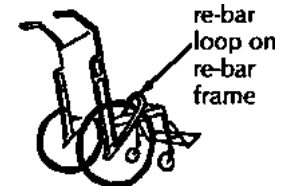

Figure

TO FOLD OR NOT TO FOLD

A typical folding chair

- folding mechanism usually with 2 scissoring flexible cross pieces and cloth or leather seat

Folding:

- narrow when folded for easier

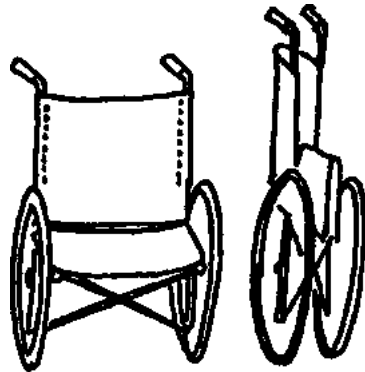

Figure

- For details of a make-it-yourself model

transport or storage

- smoother ride due to flexibility

Non-folding:

- cheaper and lighter
- easier to make
- more adaptable

- often stronger

ARMRESTS

No armrests

Note: Many chairs are built so that armrests are part of the main structure and strength of the chair. The armrests cannot be easily removed, even though this might benefit the child. Carefully consider the child's need for armrests **before** buying or making a chair.

- Many children with strong arms and trunk control prefer a chair with no armrests and a very low back support
- Moving by pushing the wheels is easier
- less weight
- Getting off and on from the side is easier- especially important when legs are

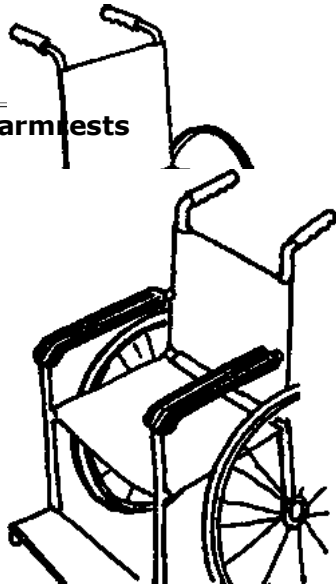
Fixed armrests**Figure**

The so-called 'desk arm' lets front of chair fit under a table (1) - but is often too high or too short.

completely *paralyzed* and when arms are also weak

- Armrest height and length should be determined for each child and her needs

- especially helpful if child cannot use legs to get out of chair

- They can help child to sit in a better position and be more comfortable

- They can sometimes be used for attaching a removable table (2)

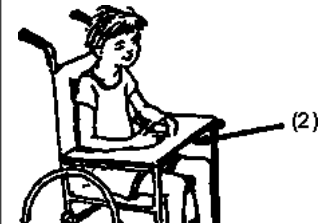
**Figure**

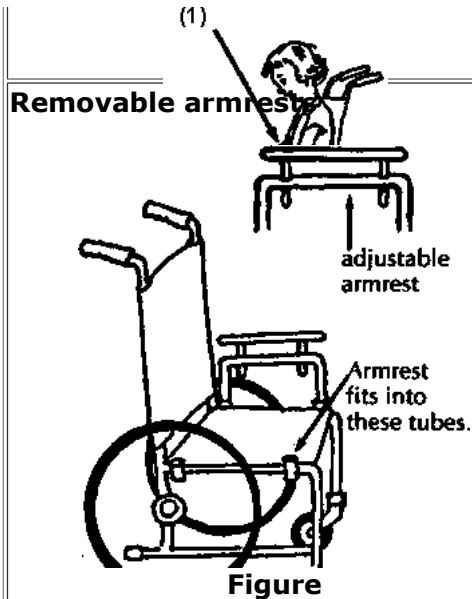

- In folding chairs, armrest attachments must be placed so they do not get in the way of folding



child transferring from a chair on a board - one armrest removed

- Provides arm support when needed, yet can easily be removed for travel and transfer

FOOTRESTS

Positions

- Footrest should keep the knees and ankles at right angles and the legs slightly separated.

- Good positioning and support of the feet help the whole body to stay in a better position.

In adult chairs, footrests often angle legs forward to leave room for casters.



Figure

For a small child, often footrests can position legs straight down. This is important in many cases.



Figure

A larger child may need to sit on cushions so that his feet are above the casters.



Figure

- It should usually not twist them or force them together.



Figure

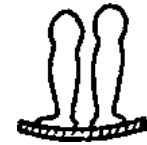

A footrest like this.



may help feet like these.

Fixed position footrests

The height of the rests should be carefully measured to fit the child who will use them.



Figure

REMEMBER: Cushions or seating adaptations will change the height needed for the footrests.

- If the footrest is too low, blocks can be 'placed on it to make it higher. They can be removed as the child grows. (1)

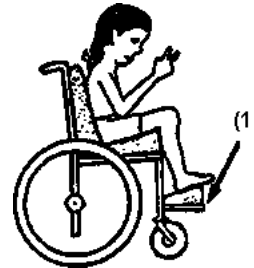

Figure

- However, fixed footrests that are too high are more difficult to correct. So it is better if they are too low.

- easiest to build
- For a small child who can easily be lifted in and out of the chair, they are fine.
- If footrests are screwed or bolted onto a wooden wheelchair, their position can easily be changed as the child grows. (2)

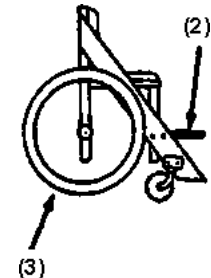

Figure

Removable or swing-away

There are many designs. Here we

- They make it easier to

footrests

wood chair swing-away footrest

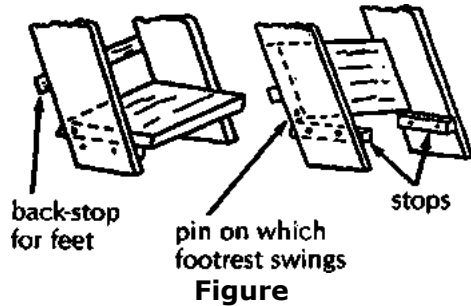

show one for the wood chair shown above and one designed for a metal chair. (3)

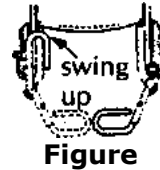

get in and out of chair.

- The best footrests are those the child can easily move out of the way herself.



Adjustable footrests

There are many designs. Here is one of the simplest, for a plywood chair.

- very adaptable
- easy to make
- can support a casted leg

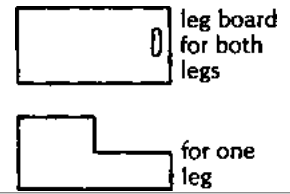
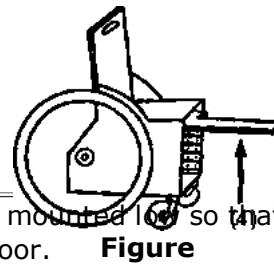
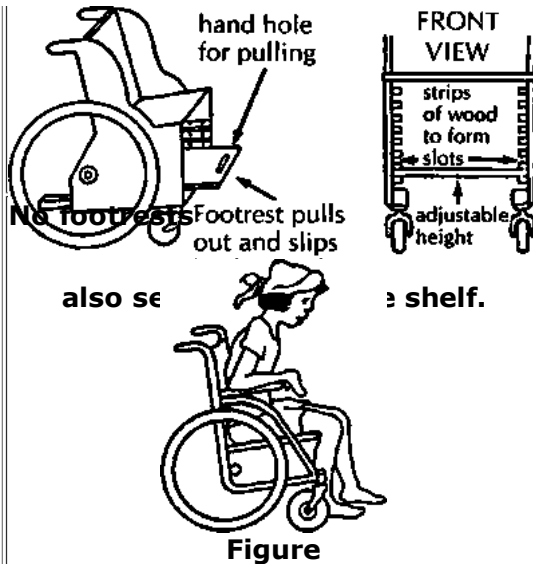

• Seat is mounted 16" so that feet rest flat on floor. **Figure**

For straight leg sitting, a longer board (4) fits into high slots.

Figure

• useful for persons who can pull their chair along with their legs and feet-especially when one or both arms or hands are too weak to push the wheels

PARKING BRAKES

Lever brakes

Brake for wooden chair

There are many brake designs. This one is from AHRTAG.

- takes little space
- fairly easy to use if made right (which often they are not)

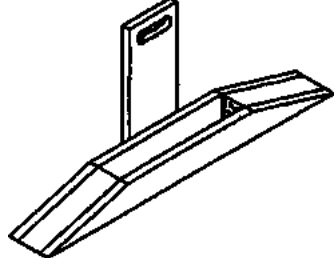
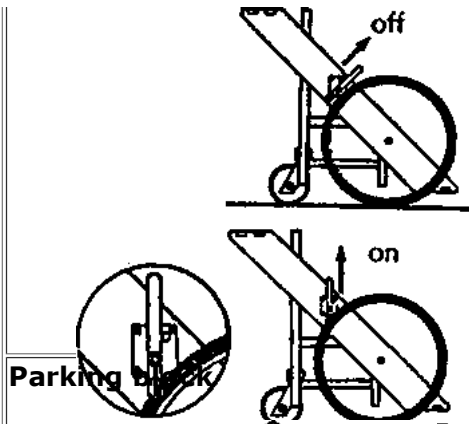

Figure

SIDE VIEW

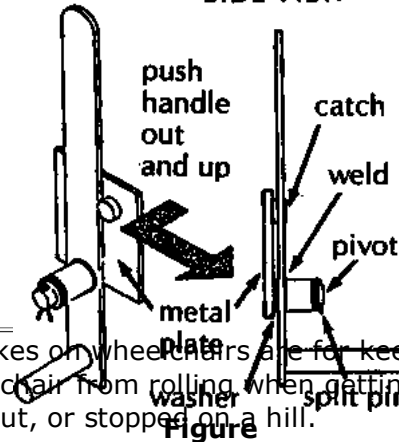

Brakes on wheelchairs are for keeping the chair from rolling when getting in or out, or stopped on a hill.

The simplest form of brake is a parking block that keeps the wheel from turning.

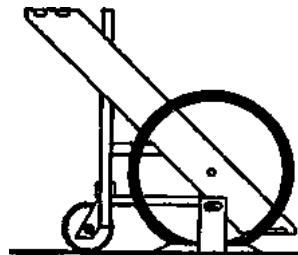

Figure

To 'brake', roll wheel up ramp and into

- easy to make, requires no welding, and is cheap

- If the child usually gets in and out of the chair in one or two places in the home, blocks in these places may be all that is needed.

HANDRIMS FOR PUSHING

using thin metal tubing

(cane or wood have also been used)

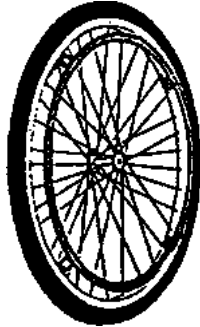

Figure

Designs taken from ARHTAG.

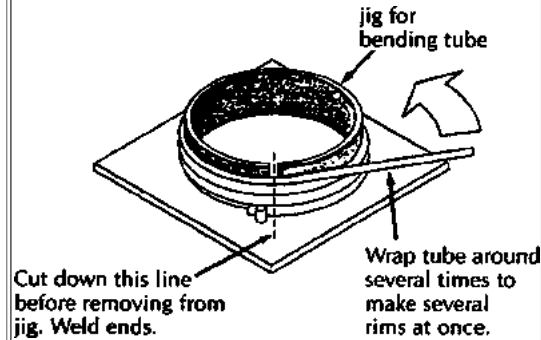

Figure

- Handrims help keep hands clean. (Otherwise child has to push on tire.)

- especially important where there are very dirty paths and roads

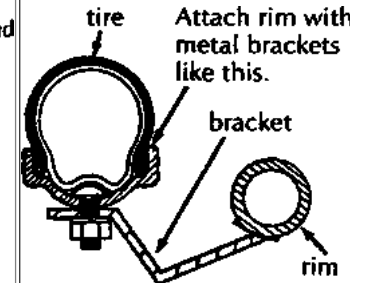

Figure

Handrim grip improvers

Cut a piece of rubber hose lengthwise and tape it onto rim.

- For child with weak or paralyzed hands, a smooth rim can be hard to grip - especially if it is chromed or galvanized

- Putting rough cloth tape a rubber hose or many small handles on

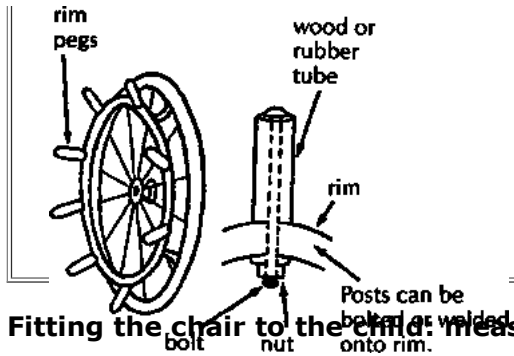

Fitting the chair to the child: measurements

Figure

These measurements are for wheelchairs, and for special seating without wheels.

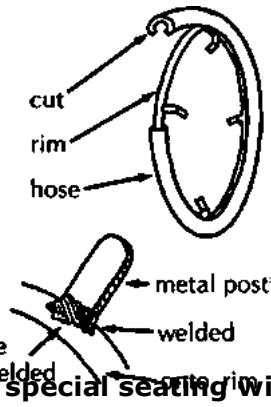

Figure

the rim will make pushing easier.

- Or you can wrap the rim with a long thin strip of car tire inner tube. (1)

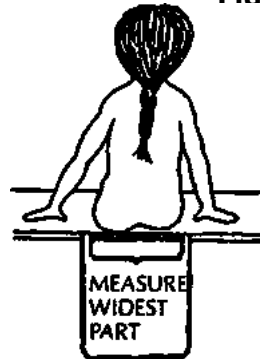

SEAT WIDTH

Measure across hips or thighs - whichever is wider.

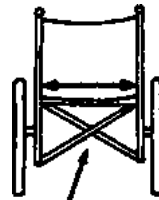

(1)
Figure

(1) Add 1 cm. (1/2 inch) to both sides for seat width.

Note: Some specialists recommend wider seats. But the child gets a better arm position for pushing the wheels if only 1 cm. is added on either side. However, you may want to leave a little more room to allow for the child's growth.

SEAT DEPTH



Figure

CAUTION: When measuring, be sure to allow for cushions or backboards that will be added.

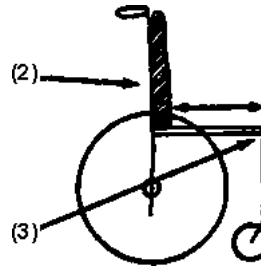

Figure

Note: You may want to add 2 cm. or 3 cm. to allow for growth - and use a backboard or firm cushion to fill in the extra space (2).

Subtract about 1 cm. for depth of seat to leave a little space behind the knees (3).

SEAT HEIGHT

CAUTION: Be sure to include cushion when measuring height for chair seat.

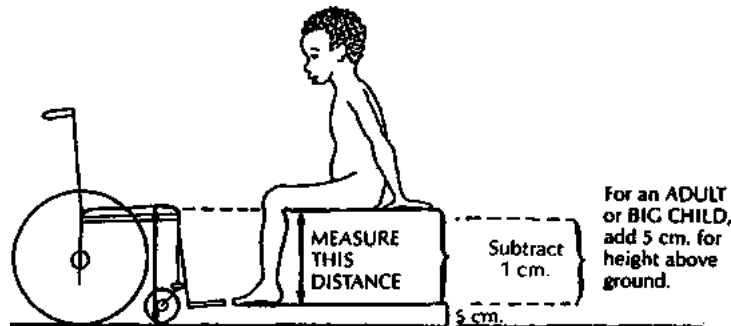

Figure

Note: Raising the seat of a small child higher lets his feet rest above the casters and therefore directly below the knees. The higher seat also helps for eating at the table with the family. Sideways transfers are also easier. Sometimes seats are placed even higher than shown, but this makes pushing wheels with hands more difficult.

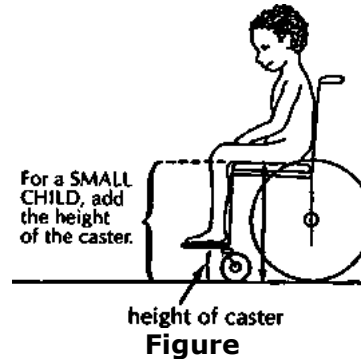

ARMREST HEIGHT

MEASURE FROM BOTTOM OF BUTT TO BEND OF ELBOW.

Before measuring, be sure child is sitting as straight as possible.

Put armrest height a little higher than his elbow so that the elbow will be positioned away from the body.

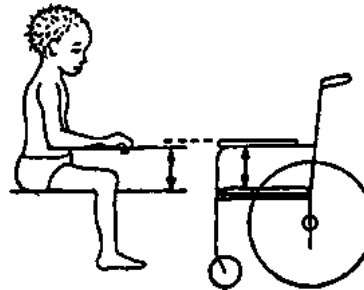

Figure

Note: This measurement is standard, but some children need arm support at a higher level. Experiment.

BACK HEIGHT

MEASURE FROM BOTTOM OF BUTT TO ARMPIT.

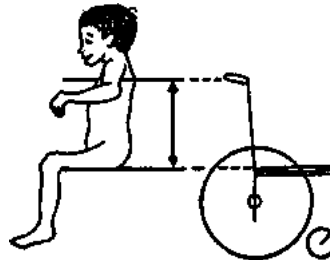

Figure

Note: This measurement is standard, but some children need a higher back, and sometimes head support. Others prefer a back that supports only the hips.

IMPORTANT: Also check how much hips and knees bend, as this may affect position of footrests and casters.

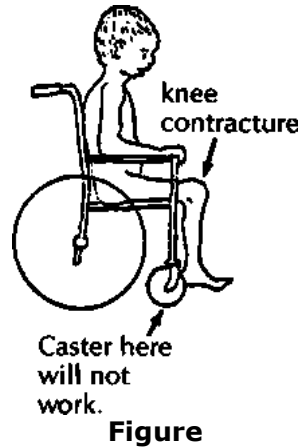

Wheelchair production as a small 'village-industry'



A disabled worker from PROJIMO paints a wheelchair frame.

In several countries small groups of disabled persons have started to produce low-cost, good-quality wheelchairs adapted to local needs. Usually this is in places where standard factory-made wheelchairs are very high-priced and are not suited for use on rough or sandy ground.

Some of these 'little factories' try to be self-sufficient. A few have even succeeded in making a modest profit, while keeping prices low.

Sometimes, a small-scale wheelchair making and repair shop is set up as part of a community rehabilitation program. Self-sufficiency (selling the chairs for a little more than it costs to make them) is often a goal. But because families with the greatest need are often least able to pay, the chairs must often be sold below cost.

WHAT KIND OF WHEELCHAIRS TO MAKE

This depends on many factors: cost, skills or training available, tools and equipment needed, amount of money available to start, building materials available, the possible market, the local economy and needs of the wheelchair user and family

For example, folding tube-metal chairs are relatively expensive to make and require more skill, training, and equipment. However, they often work smoother, last longer, and are easier to transport than are many other models. These high-quality good-looking chairs - painted or even chrome plated - may sell the best, even if expensive, and may compete with factory-made chairs.

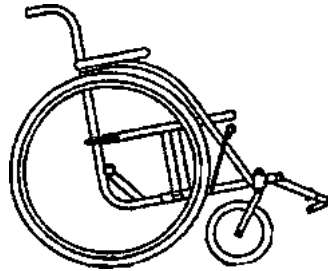

Figure

If the wheelchair users will be mostly children and poor families, low-cost wooden chairs may be more appropriate. These can be easily built to size and adapted to the needs of the individual child. The chair may not last as long. But the child is growing and her needs may change. Simple wood chairs also require fewer skills to build-mainly carpentry. They are easier for the family to build, repair, or add changes to at home.

Ideally a village shop would make a variety of chairs out of different materials and at different prices. Chairs of all models, sizes, and adaptations should be kept on hand to give the child and family a chance to know and try different possibilities. Be sure to make child-sized chairs. And make chair inserts so that adult-sized chairs can be adapted for children.

Look for every opportunity to keep costs low. Providing repair services for used and broken chairs are good ways to keep children on wheels. Also use as much 'waste', and used and free materials as you can: old bicycle wheels, old machinery bearings, scrap metal, and bolts from junk yards. For basic building materials, check prices of different sellers. Once you are sure of what you need, try to buy large amounts at lower cost. If you explain to the sellers the purpose of your purchase, they may lower prices or give you useful scraps.

How-to-do-it. Reference Materials for Wheelchairs, Wheelboards, and Other Seating

It is impossible, in a book such as this, to give detailed building plans for more than a few wheelchairs, scooters, wheelboards (trolleys), and special seats. The following reference materials have more detailed plans. You can send for them at the addresses shown. Some may also be available from TALC, P.O. Box 49, St. Albans, Herts, AL1 4AX, England. With each reference we give one or more drawings of key designs and a few comments about their usefulness and cost.

Personal Transport for Disabled People - Design and Manufacture

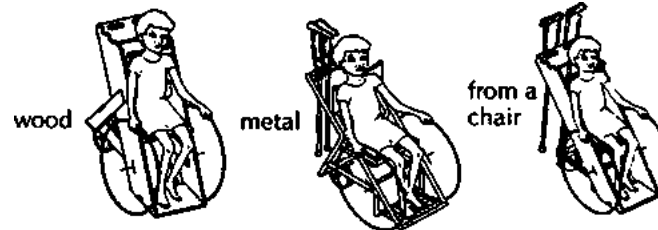

WHEELCHAIRS

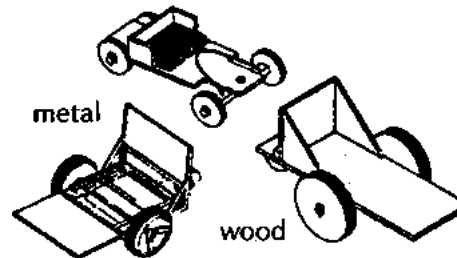

TROLLEYS



TWO-HAND DRIVEN TRICYCLE

AHRTAG

**Farringdon Point
29-35 Farringdon Road
London EC 1M 3JB
ENGLAND**

Also available through TALC

- many good designs and plans for low-cost aids
- does not compare strengths and weaknesses or describe limitations of different designs
- no design for wheelchairs with casters in front (which are needed for many areas)

Independence through Mobility: A Guide to the Manufacture of the ATI-Hotchkiss Wheelchair by Ralf Hotchkiss

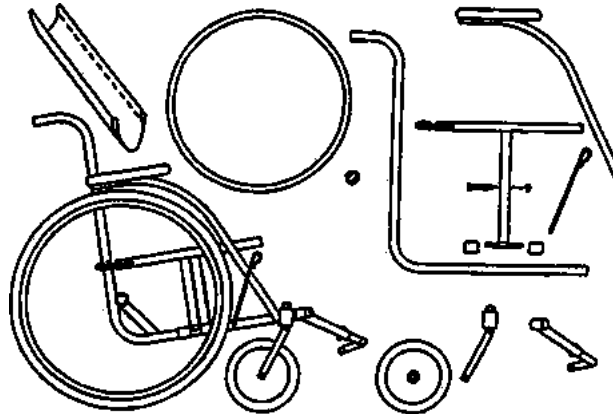

Figure

**c/o Wheeled Mobility Center
Dept. of Engineering SFSU
San Francisco, CA 94132, USA**

- **design for the 'whirlwind', a high-quality middle-cost steel tube wheelchair that can be built by disabled craftsmen as a village industry**
- **short training usually needed to build it effectively; welding skills and simple math required**
- **cost of materials about US \$100**

Local Village-made Wheelchairs and Trolleys by Don Caston

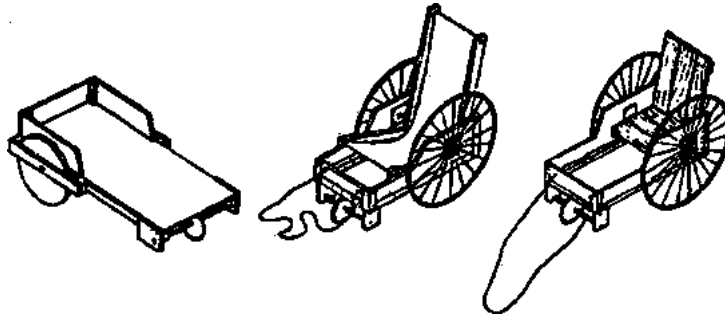

TROLLEYS

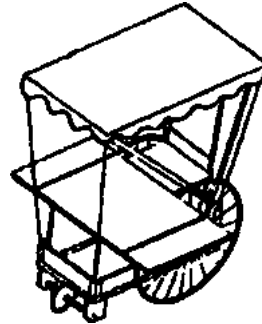

SALES CART

piece of inner tube
to center wheel
after turning

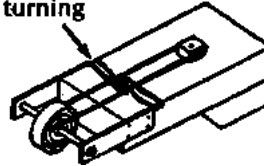

Figure

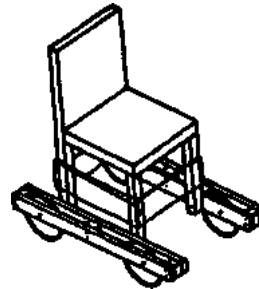

WHEELCHAIRS

Available upon request.

**DON CASTON
202 Cheesman Terrace
London W14 9XD
ENGLAND**

- **simple, very low-cost aids, made mostly out of wood, using bicycle or wood wheels**

- all models are based on one 3-wheel trolley design
- Instead of a standard caster, the front slides on its axle and is pushed back to center by a choice of simple methods. (This method is cheap and clever, but unstable and does not turn as well as designs with casters.)

Asia-Pacific Disability Aids and Appliances Handbook, Part 1: Mobility Aids, 1982



TROLLEYS

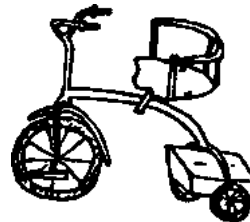

ADAPTED TRICYCLE

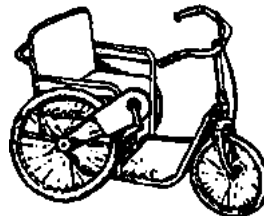

ONE-HAND POWERED TRICYCLE

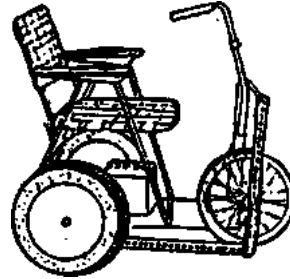

'HOMEMADE' ELECTRIC WHEELCHAIR USING CAR FAN MOTOR AND BICYCLE PARTS

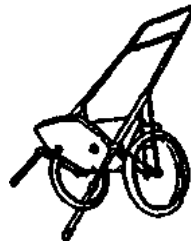

WHEELCHAIR TO BE PULLED OVER ROUGH GROUND

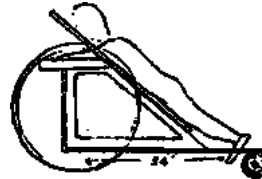

TILT CART

ICTA

BOX 510 S-162-15
Villingby, SWEDEN

- **brief descriptions and non-technical drawings and addresses for information on many aids**

An Accent Guide to Wheelchairs and Accessories



LAP TRAYS

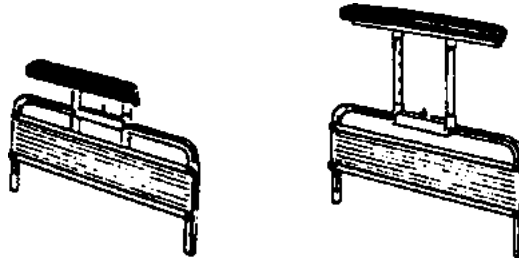

REMOVABLE ARMRESTS

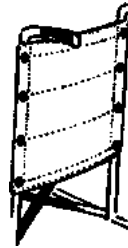

BACKS

ACCENT

P.O. Box 700

Bloomington, IL 61702

USA

- **information about different aids, features, and accessories of factory-made chairs**
- **basic information on cleaning and repairing**
- **design and building information limited to a few accessories**

UPKARAN-A Manual of Aids for the Multiply Handicapped

adjustable

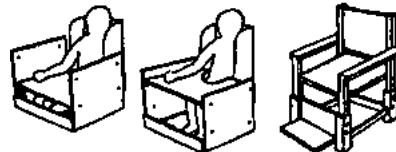

SEATS

toilet adaptation



WHEELCHAIRS

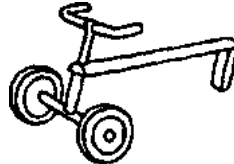

PUSH-ALONG

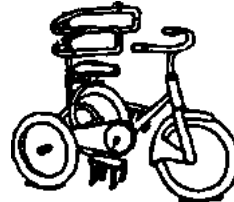

TRICYCLE WITH SUPPORT

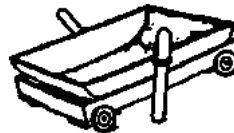

WALKER-RIDER



**The Spastics Society of India
Upper Colaba Road
Near Afghan Church
Bombay 400 005
India**

- an excellent resource
- many simple, practical designs for seating, wheelchairs, crawlers, slanders, walkers, therapy aids, and toys

How to Make Basic Hospital Equipment by Roger England and Will Eaves

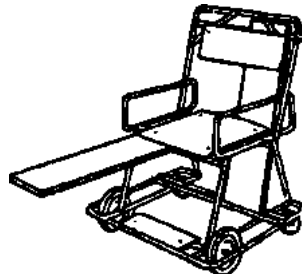

HOSPITAL WHEELCHAIR



OUT-OF-HOSPITAL WHEELCHAIR (2 wheels only)

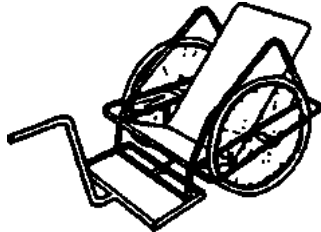

BICYCLE AMBULANCE

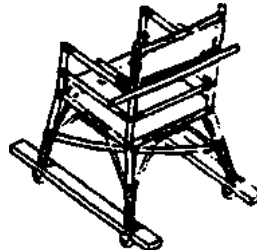

CHAIR MADE WITH WHEELS OF RATTAN (also works as a walker)

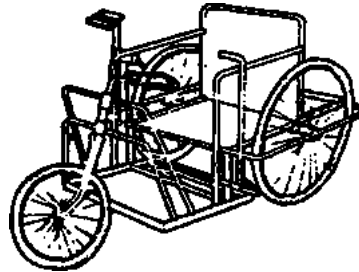

ONE-HAND DRIVEN TRICYCLE

**Intermediate Technology Publications
103-105 Southampton Row
London WC 1B 4HH
ENGLAND**

Also available through TALC and AHRTAG

- **simple, attractive designs using tube steel**
- **welding skill required, fairly costly to make**
- **no designs for casters-in-front chairs**

**Poliomyelitis - A Guide for Developing Countries
by R.L. Huckstep**

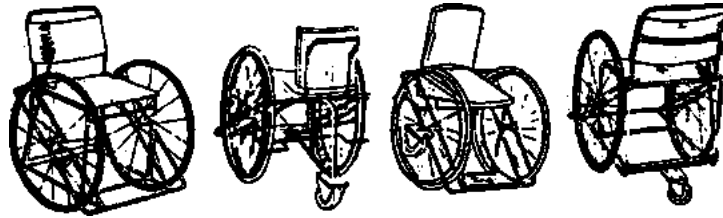

WHEELCHAIRS

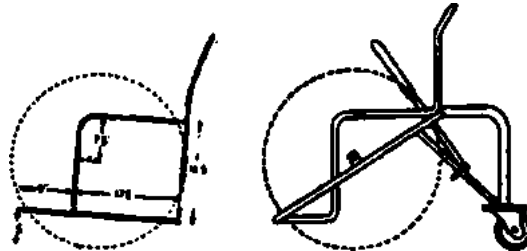

basic frame

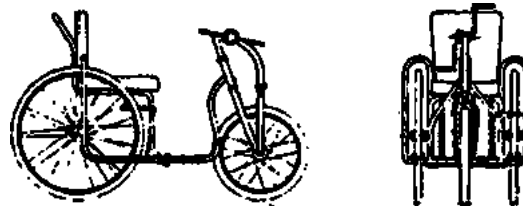

2-HAND POWERED TRICYCLE

**Churchill Livingstone
55 Fontenac Road
Naperville, IL 60563 USA**

- detailed designs for 3 models of wheelchairs commonly used in Africa
- only casters-at-rear designs (which often may not be the most appropriate design)

Positioning the Client with Central Nervous System Deficits: The Wheelchair and Other Adapted Equipment

by Adrienne Falk Bergen and Cheryl Colangelo

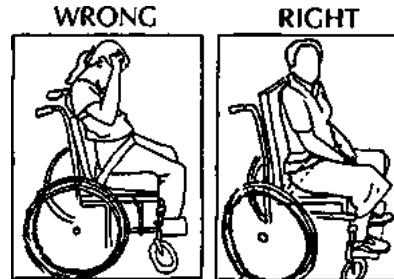

SEAT BELTS - This child, whose hips tilt forward, needs a higher belt.

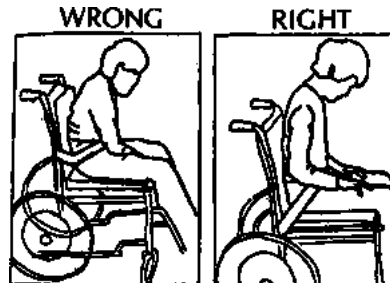

SEAT BELTS - This child, whose hips tilt back, needs a low belt.

Valhalla Rehabilitation Publications, Ltd.

**P.O. Box 195
Valhalla, NY 10595
USA**

- **excellent detailed discussion of specific needs of children with cerebral palsy**
- **many well-illustrated examples**
- **written for developed countries but many aids and designs are simple and can be made anywhere at low cost**

'Build Yourself' Plastic Wheelchair

Directions for assembly available from:

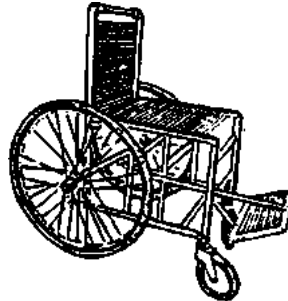

Figure

**Spinal Research Unit
Royal North Shore Hospital of Sydney
St. Leonards, NSW 2065
Australia**

- **relatively expensive (materials about US \$100)**
- **plastic frame made of 9 m. of 15 mm. PVC pressure pipe; plastic set of 8 mm. soft PVC tubing; 2 rear 24 inch bicycle wheels; 2 front casters (15 mm.)**
- **relatively expensive (materials about US \$100)**
- **Plastic will sag with continued use,**
- **uses standard bicycle axles - which will bend with the weight of an adult or large child**
- **relatively lightweight**
- **does not fold**
- **design plan complicated and difficult to follow**

Measuring the Patient

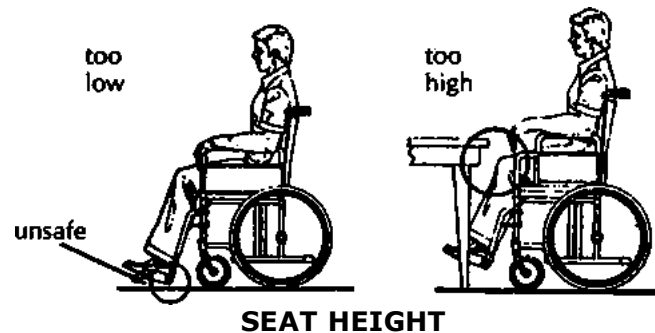

Everest and Jennings, Inc.

Available through Everest and Jennings wheelchair dealers or:

**Everest and Jennings
4203 Earth City Expressway
Earth City, MO 63045 USA**

- **good information on measurements for standard chairs**
- **illustrated discussion of problems with chairs that do not meet a person's specific needs**

**Functional Aids for the Multiply Handicapped
by Isabel Robinault**

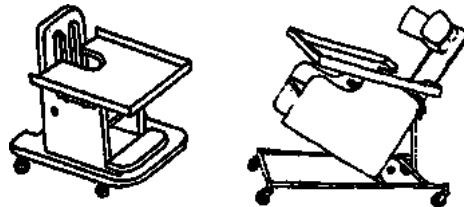

SMALL-WHEELED ADJUSTABLE WALKERS



CHILD'S TRICYCLE WITH BODY SUPPORT BOLTED TO FRAME

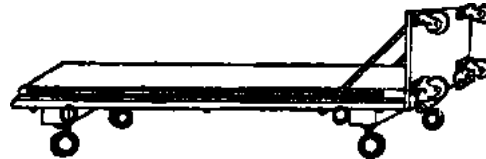

SCOOTER THAT IS ALSO A WHEELED STANDER

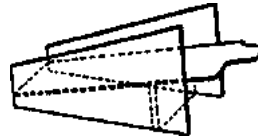

SUPPORT FRAME

**Harper and Collins Sales
10 East 53rd Street
NYC, NY 10022 USA**

- **mostly factory-built examples but some are simple and well-illustrated enough to serve as design guides**
- **many good wood special seats**
- **also support frames, standers, walkers, toys, and eating aids**

Chapter 65: Adaptations for Wheelchairs and Other Sitting Aids



Many children need more support or special *positioning* than is usually provided by a regular chair or ordinary wheelchair. So we should try to get or make a chair designed to

fit the individual child. Unfortunately, many children get wheelchairs that are much too big. Often no others are available. Here are 3 ways to adapt them.

1. If a folding chair is too wide, make the cloth seat and back narrower The chair will not open as wide (but may be too high)

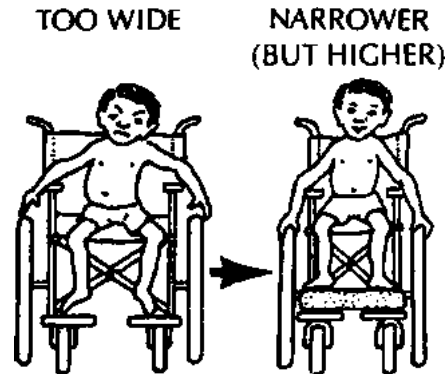

Figure

Be sure to check how well the child can reach to turn the wheels

2. If the chair is too big from front to back, or if the child needs a better position, try a wedged cushion (1) and padded backboard (2).

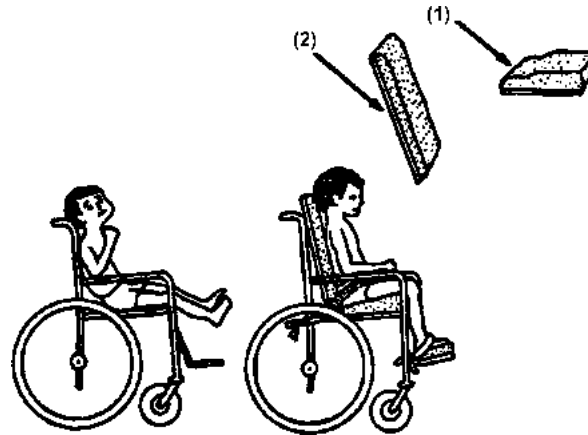

Figure

Some children need straps across their hips or ankles to keep a good position (See the precaution)

3. If still more help is needed for positioning the child, make a sitting frame designed to meet her needs Here is an example

CAUTION: Not all children will need all the special features shown here. Some will need still other features. Adapt special features to the needs of the particular child, and **test them before making them permanent.**

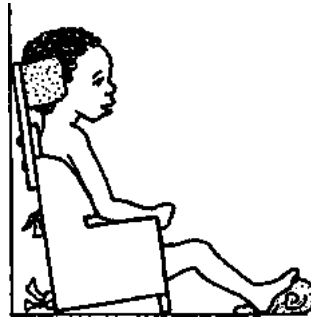
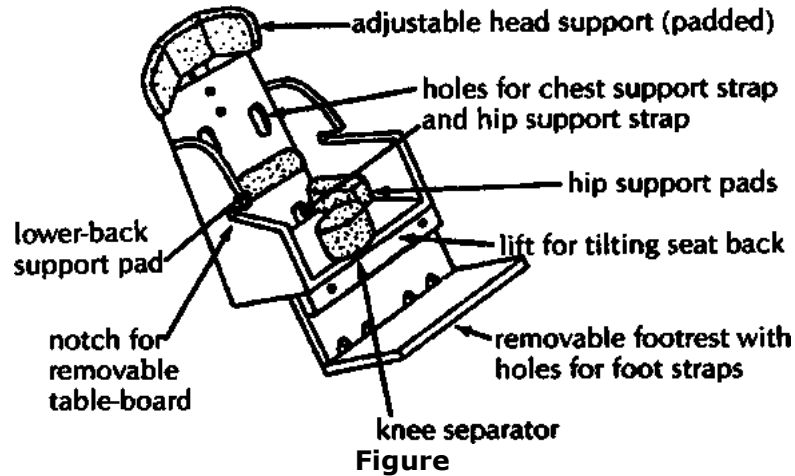

The sitting frame can be used on the ground



It can be placed in a chair (or strapped into the seat of a car)

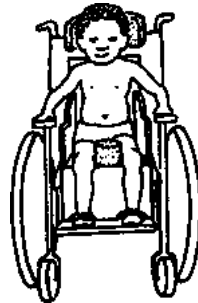

It can be fitted into a wheelchair



Or make a simple wood wheelchair with all the features of the sitting frame.

CP Seating adaptations for specific children

The various *adaptations* discussed here are designed to meet specific needs of individual children, especially children with cerebral palsy. Remember that each child's needs are different, and adaptations that are not carefully fitted to the needs of the child may do more harm than good.

- 1. Carefully consider the child's specific needs before including any adaptation or special seating.**
- 2. After making an adaptation, evaluate how the child uses it.**
- 3. Check often to see if it continues to help the child. An adaptation for a growing child may help her progress at one stage of development but hold her back a few weeks or months later.**

General position

We have talked about this a lot, but it is worth repeating:

Most children who require special seating sit best with their hips, knees, and ankles at right angles.

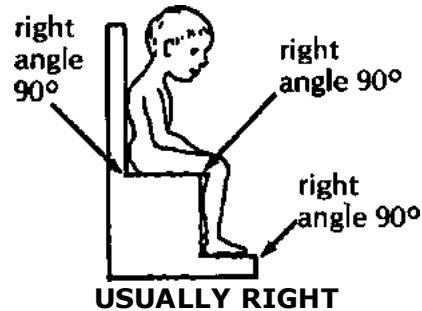

A chair shaped like this may cause a child with *spasticity* to stiffen and straighten, or cause a, severely *paralyzed* child to slip forward and slump.

ANGLE OF BODY AND HEAD



A slight backward tilt helps most children sit in a better, more relaxed position.

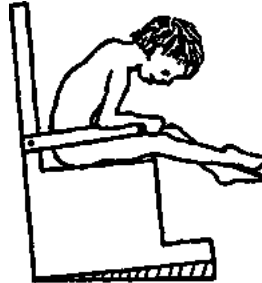

If the child still falls or stiffens forward,



it may help to tip the chair back even more.

However, this may cause his head to lean back so his eyes look upward.

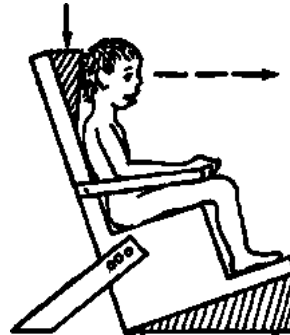

Figure

A head pad may help position him to look forward, and may decrease some spasticity. It can also reduce spasticity in the eye muscles.

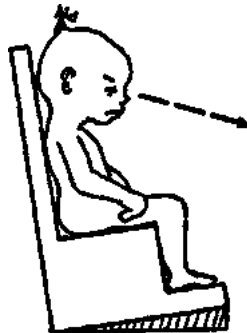

The heads of babies and small children may be so big that the headrest tilts them forward

so their eyes look down.

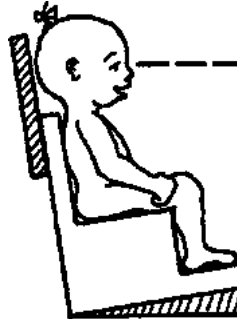

Putting the headrest behind the level of the backboard lets the child hold her head in a better position.

REMEMBER:

All the seating ideas shown on these pages apply to wheelchairs, and also to special seats without wheels.



Figure

CP Other ways to help keep hips at a right angle

HIP STRAPS

If the hips tilt back like this (1)



**WRONG
Figure**

a high hip strap will not help much

A low hip strap helps keep the hips at a good angle

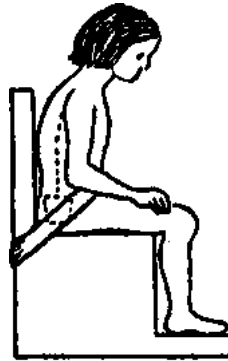

**RIGHT
Figure**

But if the hips tilt forward like this (1).



Figure

a low hip strap will not help much

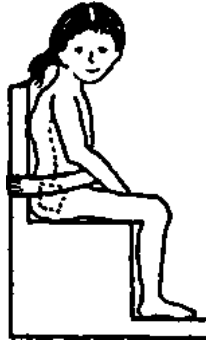

A high hip strap helps keep the hips at a better angle

Notice that in both of these children with cerebral palsy, supporting the hips in a better position helps the whole body take a more normal position.

SPECIAL CUSHIONS



WITHOUT CUSHIONS

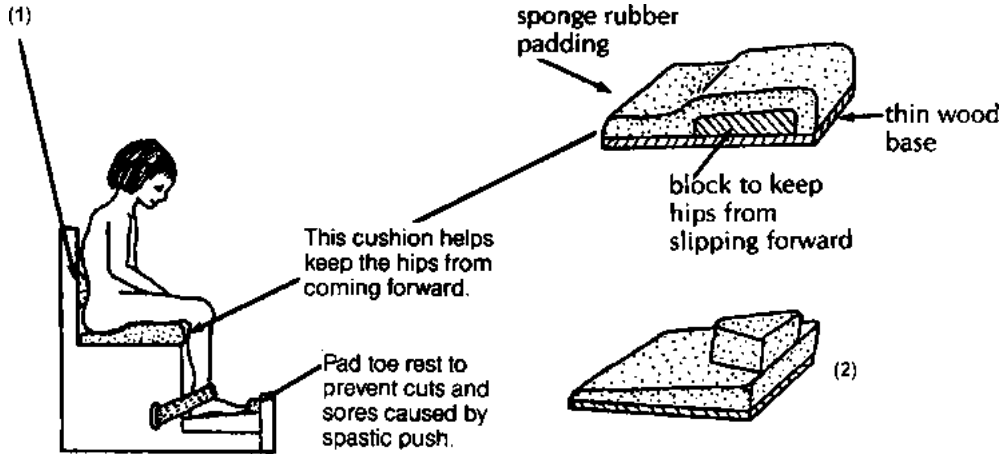

WITH CUSHIONS

For the child whose hips tilt back, or whose upper body is 'floppy, a padded support

across the lower part of the back may help her keep a good position (1).

A padded post may also help to keep hips back and legs apart (2).

A footstrap or block that keeps knees bent may help keep the child from straightening stiffly

Good cushions sometimes make straps unnecessary

Keeping the body straight from side to side

Even with a firm board seat this boy's body sags to one side. This can lead to increasing curve of the spine (scoliosis)

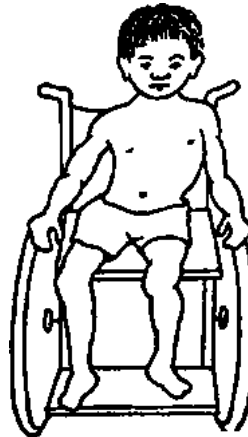

Figure

Hip guides may help him sit straighter

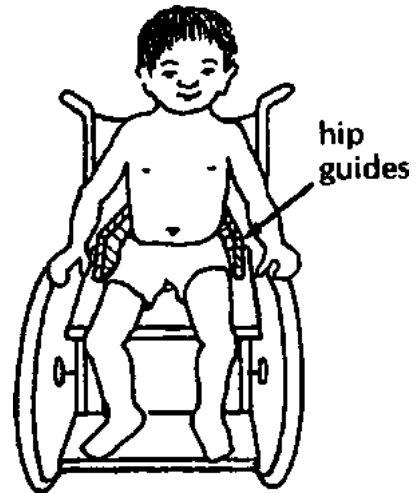

Figure

Sometimes hip guides alone are not enough



Figure

He may also need carefully placed body guides to help keep his body in a straighter position

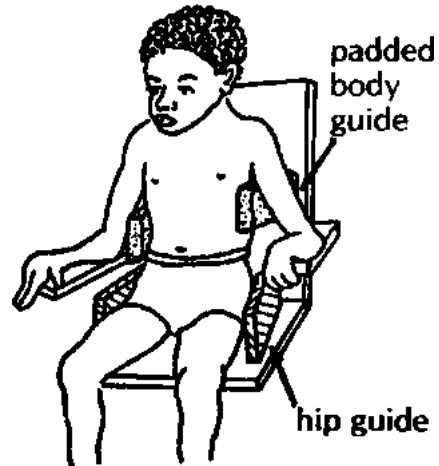

Figure

CP Deciding where to place body guides

- 1. Look carefully at how the child sits.**

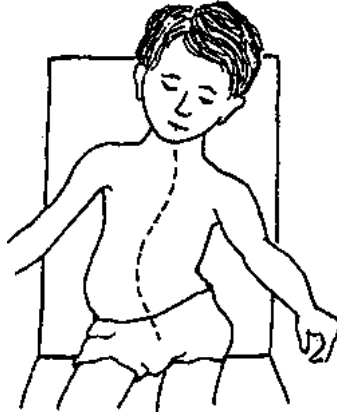

Figure

2. Draw a sketch of how he sits. Then draw arrows where you would need to push to help him sit straighten

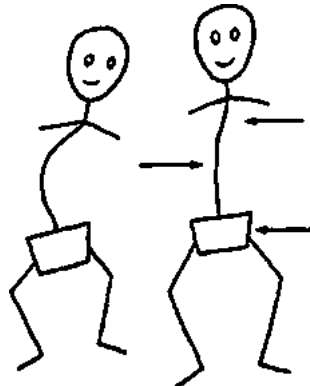

Figure

3. While someone holds the child in his best position, mark where you think the guides ` should be placed.

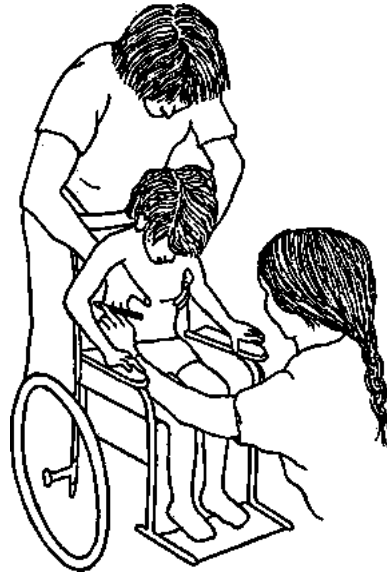

Figure

4. First, build in the guides in a temporary way.

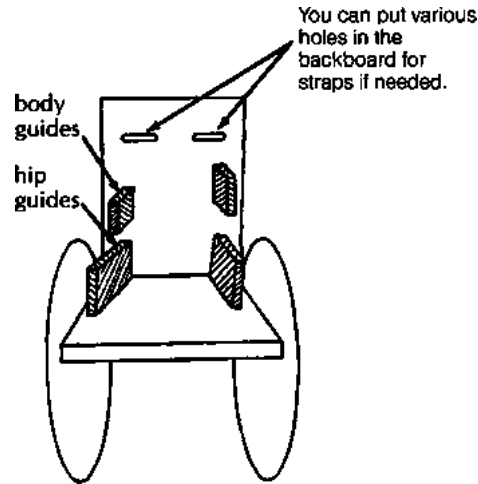

Figure

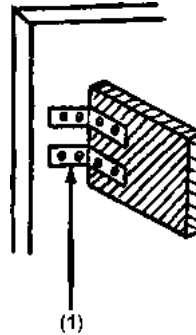

Figure

The guides (1) under the child's arms should be thin. To hold their position you can use

angle irons.

5. See how well the child sits in the adapted seat. When you cannot improve it more, fasten the guides firmly and pad them so they do not hurt him.

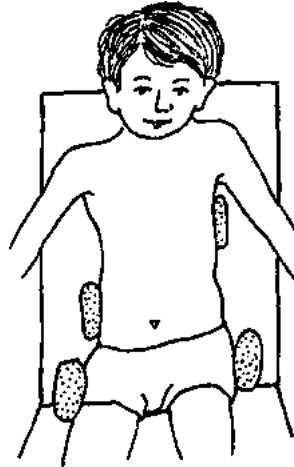

Figure

An 'H' harness, with straps that pass through slots in the backboard, is another way to help hold steady the body of a severely disabled child.

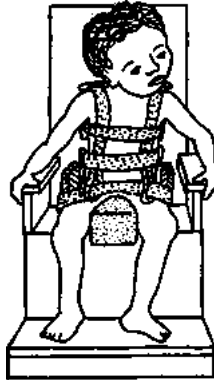

Figure

CP Carefully evaluate what kinds of support each child needs.

Maria's legs straighten, press together, and turn inward. Her whole body position is affected.

A hip strap holds her hips back some but does not help her overall position much.

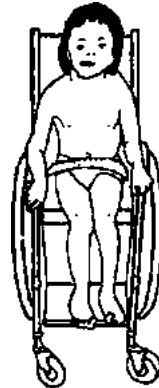

Figure

However, a backboard that bends her hips more, plus a knee post, help improve her whole body position-without straps!

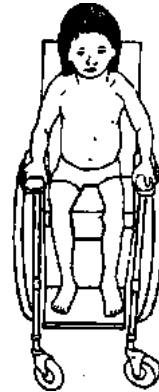

Figure

Pedro is a heavy child whose body stiffens and his knees push open.

A combination of a backboard with guides, a special cushion and a knee block does not help him.

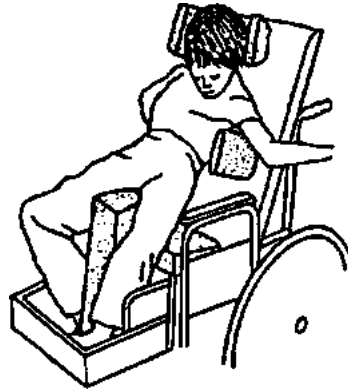

Figure

However, a hip strap together with blocks outside his knees gives him a much better position, (He may also need foot, straps.)



Figure

SHOULDER-BLADE WINGS

Pablito's spastic muscles pull his shoulders back and make it hard for him to bring his hands together in front of him. The village team had an idea.

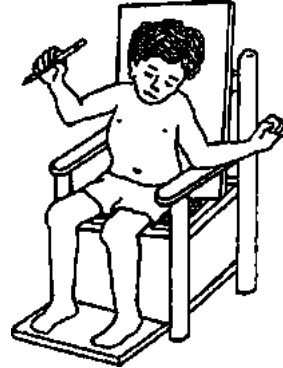

Figure

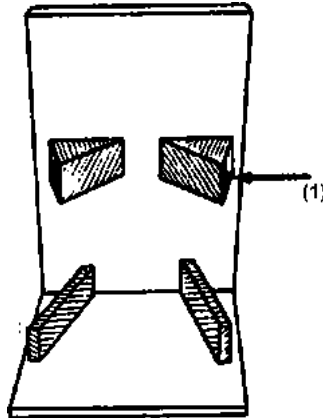

Figure



Figure

They put “wings” behind his shoulder blades (1), to help keep his shoulders forward.

Now Pablito can bring his hands together and play more easily

LAP BOARDS

These can be made from thin wood, plywood, or fiberboard. They should be easy to take off, but grip firmly when in place.

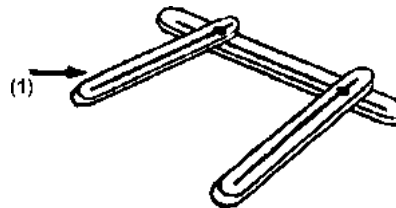

Figure

You can make a simple instrument out of cardboard or stiff paper to measure the child’s body for cutting out the lap board (1).

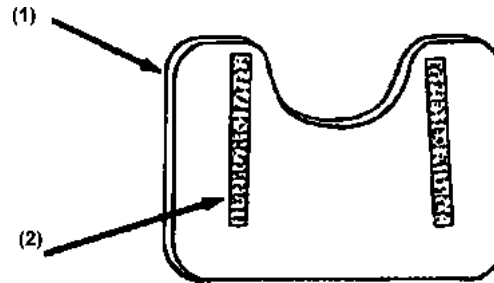

Figure

A lap board (1) can help keep shoulders, arms, and body in a better position, especially if it has a part cut out measured to fit around the child.

'Velcro' (stick-to-itself tape) (2) can be used to fix the board to the chair for easy removal - and to adjust it forward or backward.

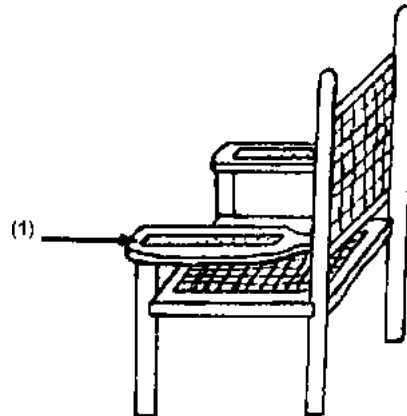

Figure

Be sure to put the softer part of *Velcro* on the chair arms (1). The rough parts could scratch the child when the boards is not used.



Figure

(1) Extra holes for changing peg position.

(2) Raised edges help keep toys from falling.

(3) Two pegs to hold onto may help him sit, or move into a better position. They also help him develop hand control (games with rings, etc.)

Height of the lapboard is usually the same as for armrests. Experiment to find out what works best.

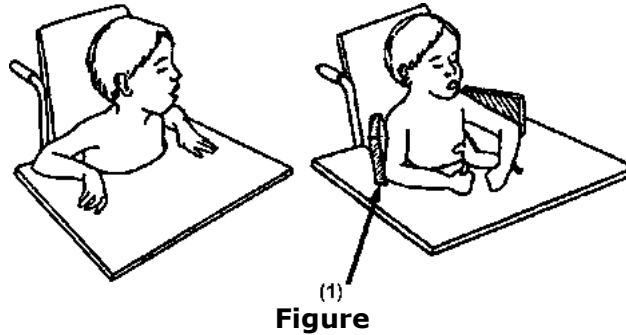

Figure

If needed, arm guides (1) can be used with a lap board to keep a child's shoulders forward and his arms in a better position to use his hands.

CP DESIGN FOR A WHEELCHAIR INSERT

This insert, from *Positioning the Client with Central Nervous System Deficits*, provides a lot of control, and is especially useful for some children with spasticity. Although it was designed as an insert for a wheelchair, you can use it as the frame of a wooden wheelchair, or chair without wheels built for a specific child.

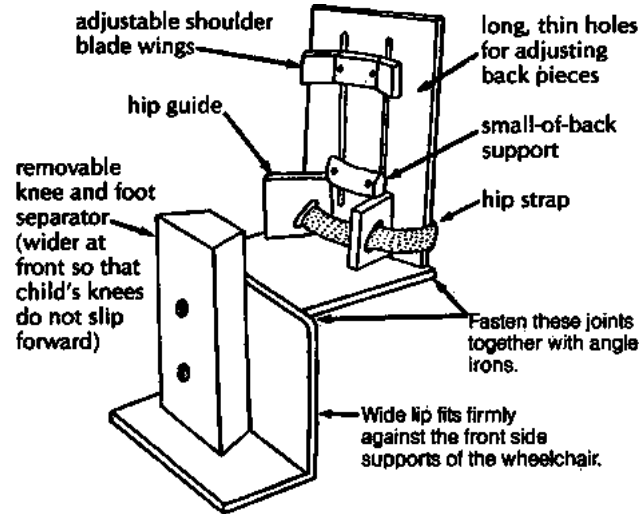

Figure

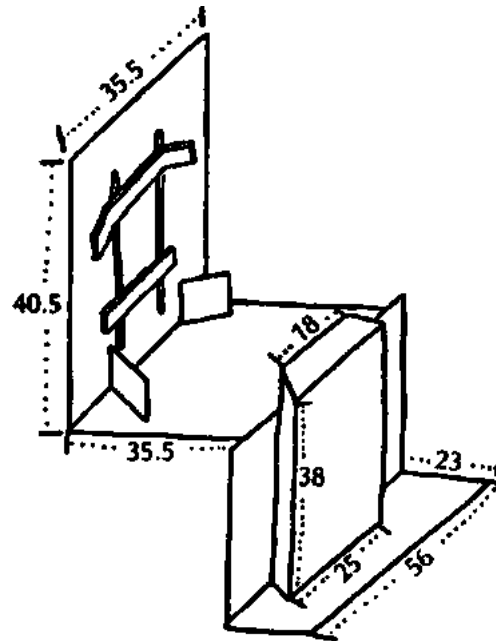

Figure

measurements of an insert to fit a standard "junior growing wheelchair".

The height and depth measurements must be adapted to the individual child.

Measurements are given in centimeters (cm.). To change to inches, divide by 2.5.

DESIGN FOR A STRAIGHT-LEG SITTING FRAME (mostly for very young children)

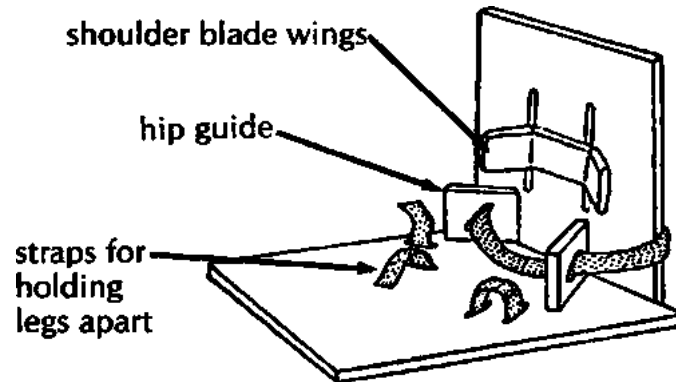

Figure

To seat the child, the frame can be put on the ground, a table, a chair, or into a wheelchair.



Figure

DESIGN FOR AN ADAPTED CASTER CART (WHEEL BOARD)

Use the same suggestions for supports, guides, and straps.

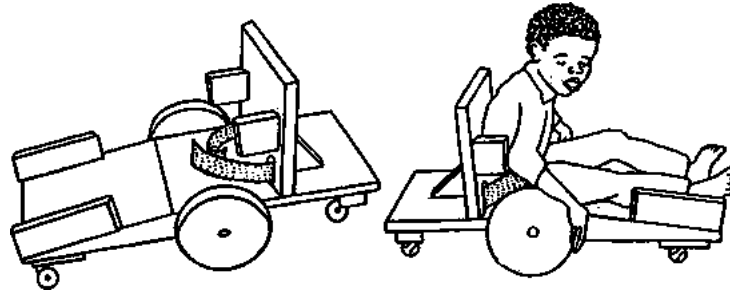

Figure

Note: The child's weight is over the large wheels. He can rock from one caster to the other. For travel over rough ground, he will learn to balance on the center wheel and barely touch down with the others.

CAUTION: Be sure to add cushions or adequate padding to all seating designs. Children whose bodies push in uncontrolled ways can very easily develop pressure sores (see Chapter 24).

Chapter 66: Designs for 6 Basic Wheelchairs

There are dozens of designs for low-cost, 'appropriate technology' wheelchairs. Some are lower cost and more generally useful than others. In PROJIMO, we have built many different wheelchairs. In this chapter we give designs for 6 of the ones that we have found most useful. Each has advantages and disadvantages.

AHRTAG wood wheelchair made from a child's chair, bicycle wheels and axles at front, one rear caster



Figure

Advantages: the simplest and one of the cheapest chairs to make, easy to modify or adapt, very little welding needed, can be built in one day by someone with some carpentry skill, low cost

Disadvantages: Single, small rear wheel makes it difficult for either the child or helper to push over rough ground or up curbs. Fixed footrest makes it hard for child to climb in and out without tipping chair forward when weight is on footrest. Sideboard makes *transfers* to side and lifting child from behind difficult

Re-bar and woven plastic wheelchair steel construction rod frame with woven plastic seat, back, and footrest

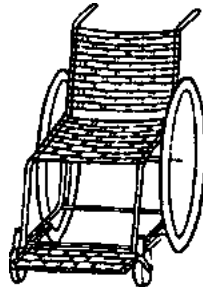

Figure

Advantages: simple design fairly low-cost re-bar is easy to bend, plastic woven seat is comfortable and easy to clean slide-away footrest makes getting in and out easier

Disadvantages: Builder needs welding skills, relatively heavy and not as strong as tubing chairs. Big bumps may bend the chair out of shape

Square metal tube wheelchair frame bolted together

Advantages: strong, stable metal chair that can be built with nuts and bolts (welding needed only to attach front wheels) Flat surfaces make it easier to put on wood *adaptations*; fairly low cost

Wheelchair with lying board made of steel tubing, with removable wood lying board

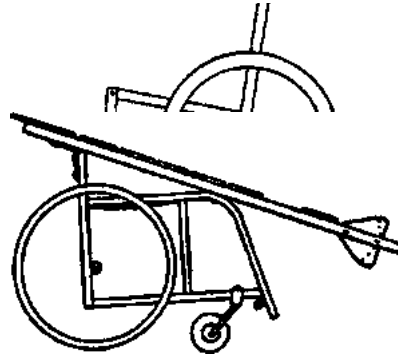

Figure

Disadvantages: more work and skill needed than for above chairs design more complex, slightly higher cost than wood chairs

Advantages: useful for active child who must lie face down to heal sores or stretch *contractures*. When board is removed, it is a regular wheelchair, low cost very adaptable

Disadvantages: requires welding (but a simpler model can be made of wood) does not fold board takes up a lot of space stiff ride

Plywood frame wheelchair with 20 inch bicycle wheels and axles, and 2 front casters

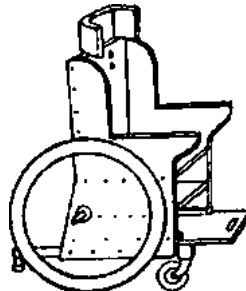

Figure

Advantages: attractive, lightweight, low cost, easy to make and adapt. Caster wheels in front (not in back) make it easier to go over rough ground and curbs. Adjustable push-away footrest makes *positioning* and getting in and out easy

Disadvantages: Plywood and double casters increase cost (although it is still a cheap chair) Plywood (if not marine grade) may come apart in wet weather. Bicycle axles may bend or break with a heavy child or

Metal tube folding wheelchair made from thin-wall steel tubing, strong axles with machinery bearings

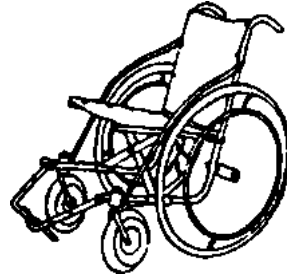

Figure

rough use

Advantages: Chair folds for transporting or storage, very tough, flexible design good for uneven surfaces good for side transfers a very high-quality chair if well-made

Disadvantages: needs more skill (tube bending, welding exact fittings, wheel spoking, etc) to build, relatively costly, hard to adapt

Tools needed for making wheelchairs

Ideas for setting up a workshop for *disabled* workers are discussed in Chapter 57 and Chapter 64. How you equip your workshop for making wheelchairs will depend on (1) how much money you have (or can borrow) to do it, (2) the kinds of chairs you hope to build (metal or wood), (3) the skills, *physical* and *mental* abilities, learning potential, and responsibility (regarding safety) of the workers, (4) the availability of electricity and power tools, (5) how many persons will be working, and (6) how many chairs you hope to produce.

Here we list the basic equipment you will need for making the 6 wheelchairs described in this chapter. Many choices are possible. More specialized parts of the work can be done by

outside crafts persons. For example, in a wheelchair production center in Belize, axles must be machine tooled on a metal lathe. Local machine shops cooperate by doing this free.

CODE AN - Absolutely necessary N - A big help, but you might do without it (N) - Necessary only for axles ? - Depends on model	TYPE OF CHAIR					
	wood chair	re-bar and woven plastic	square metal tubes with wood seat and back	wheelchair with lying board	plywood	round metal tube
TOOLS REQUIRED						
bench vise	N	AN	N	AN	(N)	AN
tubing bender				AN		AN
welding (brazing) equipment	(N)	AN	N	AN	(N)	AN
metal saw	(N)	AN	AN	AN	(N)	AN
wood saw	AN			AN	AN	
hammer	AN	AN	AN	AN	AN	AN
wrench (set or adjustable)	N	N	AN	AN	N	AN
metal file and/or grinder	(N)	AN	AN	AN	(N)	AN
screwdriver	AN	AN	AN	AN	AN	AN

SCREWDRIVER	AN	AN	AN	AN	AN	AN
sewing equipment (hand or machine)			?	N?		N?
drill (hand or electric)	N	?	AN	AN	N	AN
drill bits for metal			AN	AN		AN
drill bits for wood	AN		AN		AN	
spoke wrench	?	?	N	N	?	N
bicycle pump	?	?	?	?	?	?
center punch	N	N	N	N	N	N
tape measure	N	N	N	N	N	N
carpenter's square	N	N	N	N	N	N

Terms for metal tube or bar used to build wheelchairs

- ***Thin-wall*** refers to thin steel tubing often used for electrical wiring work and sometimes for lightweight metal furniture.
- ***Thick-wall*** refers to heavy weight pipe such as the one used in plumbing.
- ***Re-bar*** refers to solid metal rod, usually used to reinforce cement.

Jigs or guides for more exact welding

For making the metal tube chairs and the welded wheel mounts and hand rims of any of the chairs, your work will be easier and more exact if you make or purchase certain 'jigs' or guides to hold parts in the right place while you weld them. For example, to weld the front caster fork you can make a 'jig' like this. Details on 'jigs' and other techniques for making different wheelchair parts are well described in Ralf Hotchkiss's book ***Independence Through Mobility***. We strongly recommend it to any group planning to make

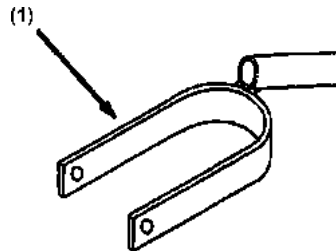
wheelchairs. (1)**Figure****Notes on measurements**

For some of the wheelchair designs in this chapter, we give the measurements for a standard child's or adult's model. **Be sure to adapt the measurements to the size and needs of the particular child.**

In many countries inches (") are used for measurements of certain things, and centimeters (cm.) for others. We therefore also use both. **Centimeters** is abbreviated **cm.** and **inches** is abbreviated ". Two inches is written 2". 1" equals 2.54 cm. You can use the scale on the edge of this page (and on the inside back cover) to change inches to cm.

AHRTAG WOOD WHEELCHAIR (Somewhat modified from AHRTAG manual)

The AHRTAG wheelchair is built onto an ordinary child's wood chair. Measurements should be adjusted to the child's needs.



Figure

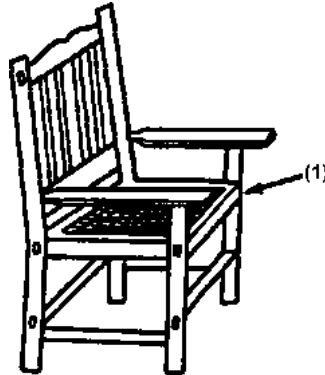

Figure

(1) A webbed plastic seat lets air move through it and can be easily cleaned.

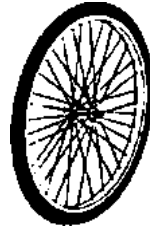

It uses standard 20" × 1 3/4" bicycle wheels and axles.

Basic carpentry tools are needed to build this wheelchair. It can be made in one day by someone with basic carpentry skills. The local blacksmith may be able to help weld together the wheel supports if you cannot. It is easy to add positioning aids or make other adaptations. The cost in Mexico using new materials is about US \$40.00.

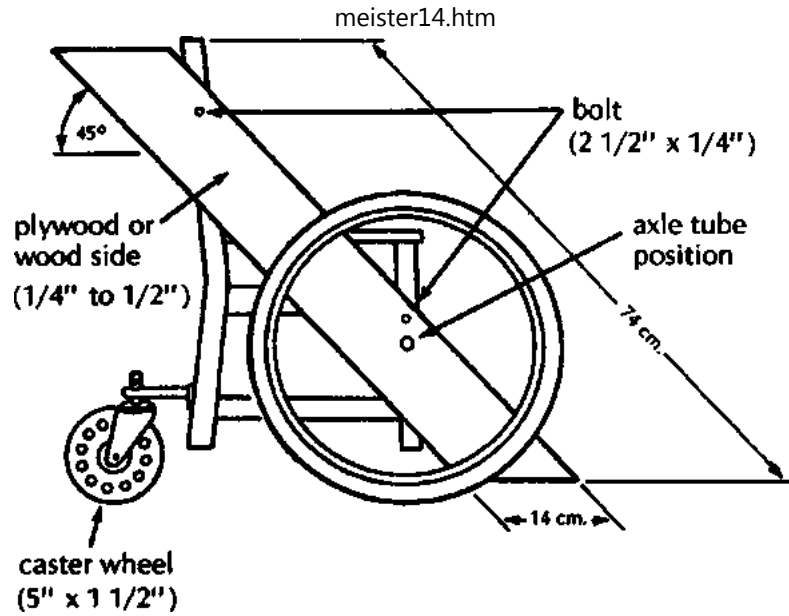

SIDE VIEW

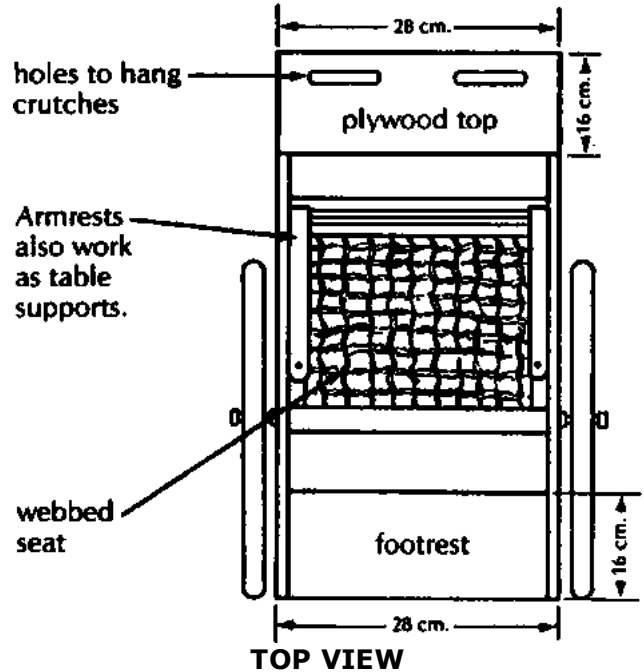

AXLES

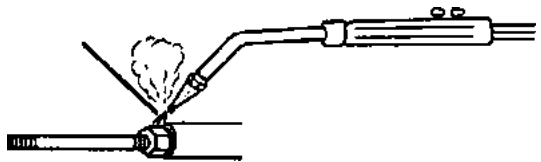

Weld axles to ends of a steel tube 2 cm. longer than the chair is wide.

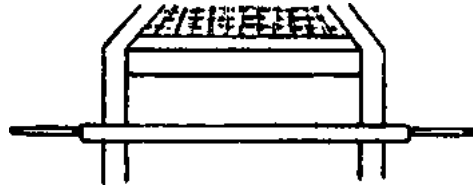

Figure



Weld axle perfect straight.

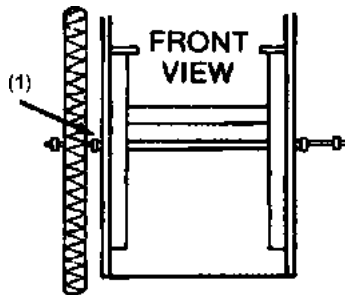

Figure

(1) pass axle tube through holes drilled through sideboards and front chair legs.

WARNING: Use standard bicycle axles this way only for children under 20 kg (50 lbs.). A heavier child, or rough use, will bend or break the axle.



Figure

(1) For children over 20 kg., use a stronger axle. Or support the bicycle axle from both sides.

CASTERS

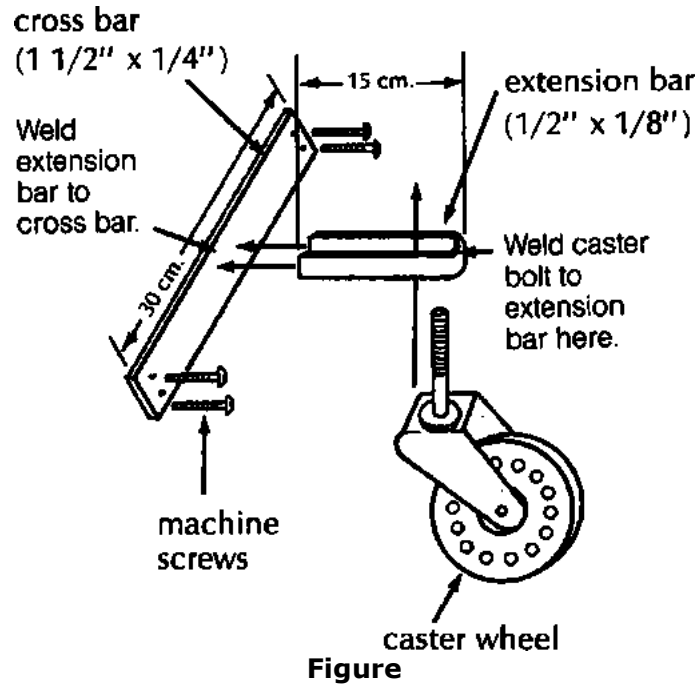

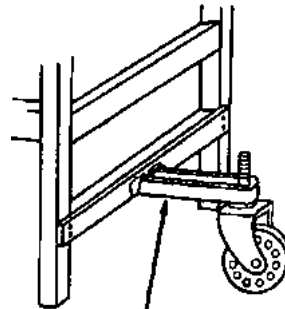

(1)
BACK VIEW

This backward extension (1) distributes weight better and keeps chair from tipping backward on hills.

Two back casters are more stable and make it easier for the wheelchair to go up curbs.

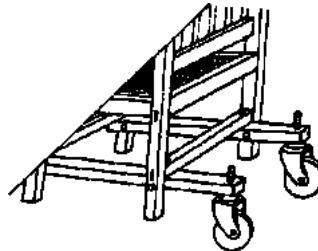

Figure

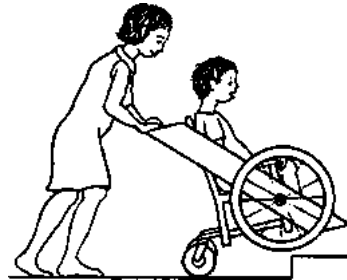

Figure

RE-BAR AND WOVEN PLASTIC WHEELCHAIR

Total cost using new parts is about US \$40.00.

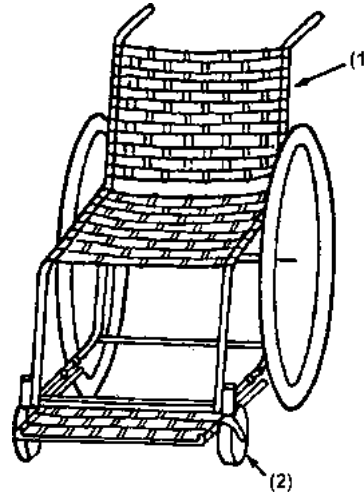

Figure

Weave back, seat, and footrest with ribbon, (1) local wicker, cane, rattan or polyethylene plastic.

For front fork and casters (2), use factory made casters or make your own (see above).

Or use thin, tightly stretched strips of car inner tube, or canvas webbing.

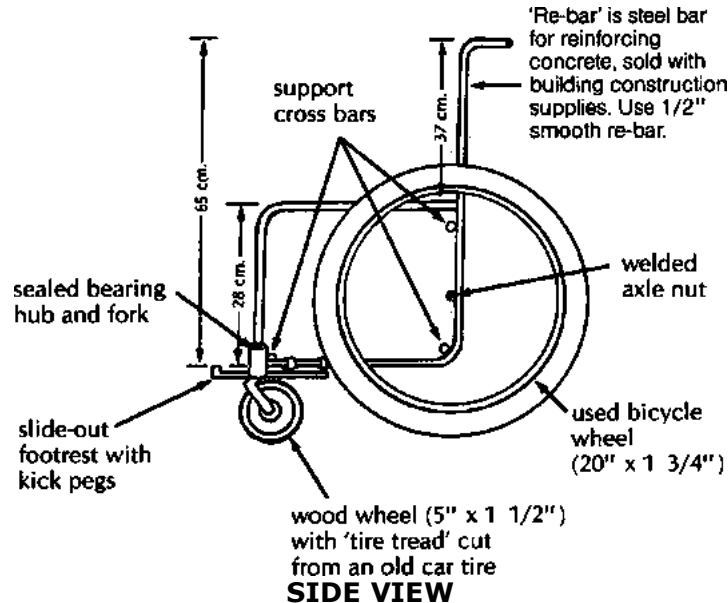
**SLIDE-OUT FOOTREST**

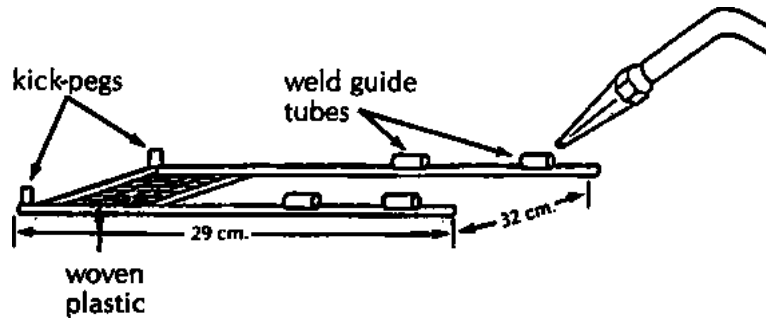

Figure

MATERIALS NEEDED

- 1/2" re-bar (4 1/2 meters)
 - inner tube strips
 - bicycle wheels (2)
 - front casters (2)
-
- webbing for seat

SQUARE TUBE WHEELCHAIR

This wheelchair, like other steel tube chairs, should use only thin-wall tubing. Total cost in Mexico using new parts is about US \$40.00. To keep costs down, check with various sources of materials and ask at small fix-it shops for advice and possibly even some free scrap material. Metal scrap heaps are great for materials.

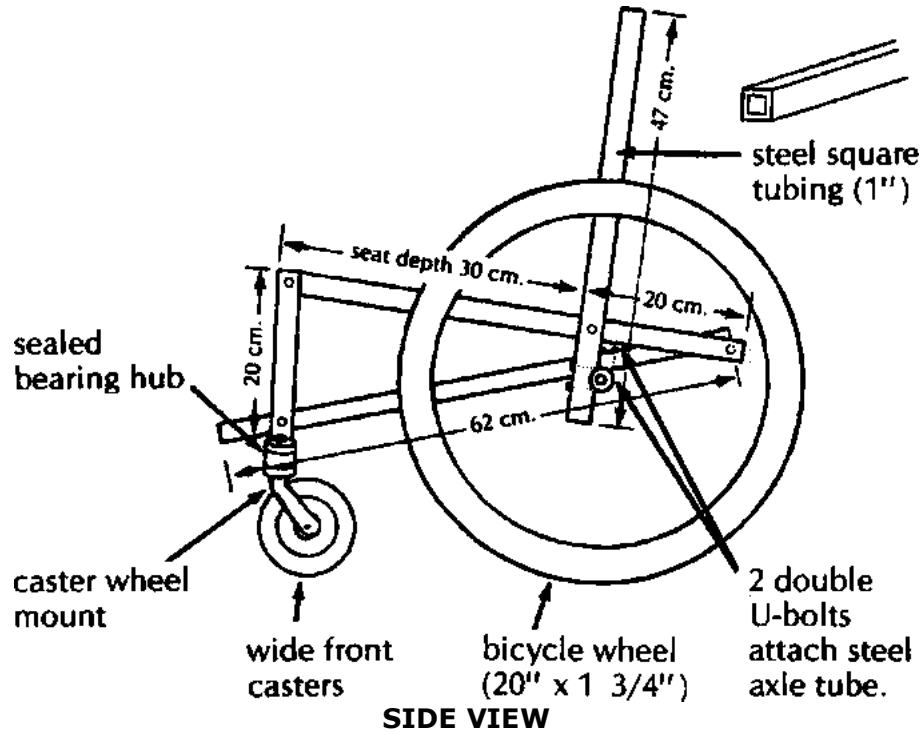

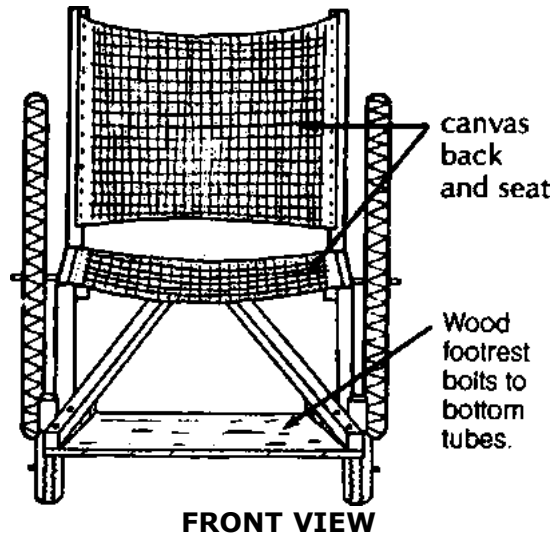

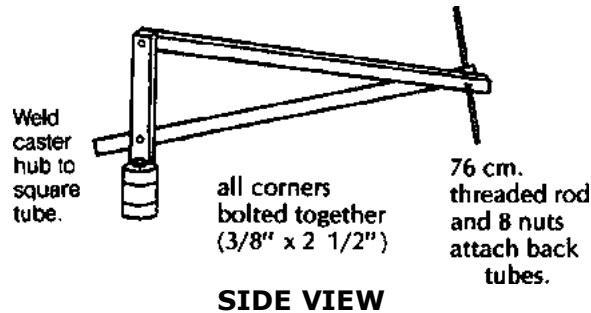
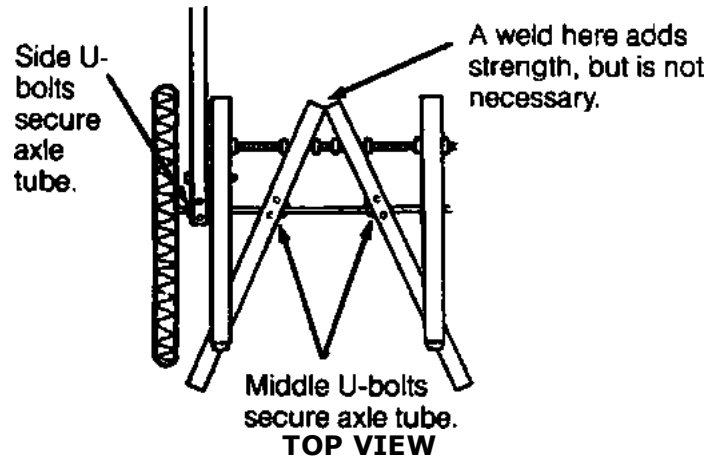

MATERIALS NEEDED

- thin-wall square tubing (1" x 3.64 meters)
- thick canvas cloth (1 square meter)

- galvanized steel tube (1/2" × 66 cm.)
 - bicycle wheels (2) (20" × 1.75") caster wheels (2) (wood or rubber)
 - threaded rod (3/8" × 38") (Use extra 20" to bend 4 U-bolts.)
 - 2 front casters
-
- 21 3/8" nuts and 12 screws for seat and back supports

HOW TO MAKE YOUR CHAIR

1. Review drawings. Adjust measurements to fit child.
2. Cut all sections of square tubing. Make sure that matching tubes are equal in length.
3. Drill holes in bottom tubes and pass the threaded rod through them. Adjust nuts until a 'V is formed. (Weld tip of 'V for extra strength.)
4. Drill all holes in seat tubes. Pass threaded bolt through seat holes.
5. Drill holes in back support tubes and front caster tubes. Bolt to frame.
6. Weld axle nuts to ends of axle tube. Drill holes for U-bolts and bolt axle tube to frame.
7. Weld front caster forks to front tubes.
8. Sew cloth back and seat supports. Screw into place.
9. Cut out and bolt wood footrest to frame. (Use wedges to get the angle right.)
10. Attach axle tube with U-bolts and put on the wheels.

11. Paint frame to help keep tubes from rusting (if not galvanized).



The same design can be made of wood.

WHEELCHAIR WITH LYING BOARD

This is useful for an active child who must lie face down to heal pressure sores or to stretch hip and knee contractures.

The board is sloped so that the child can play, look ahead, and move about more easily. If necessary, you can make the lying board adjustable so that the child can rest lying flat. This helps to improve *circulation* and to prevent swelling of the feet.

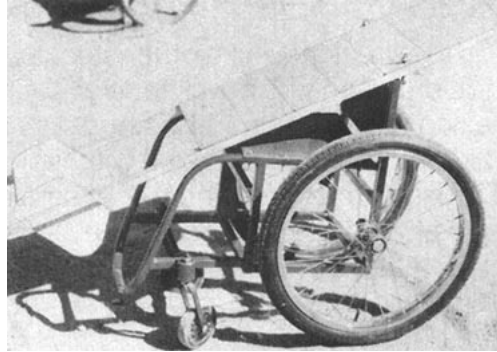

Figure

After the pressure sores heal, the lying board can be removed and the frame is easily adapted to form a lightweight wheelchair. The cost for materials in Mexico is about US \$40.00.

The design we show uses a simple, non-folding steel tube wheelchair frame with a wooden lying board mounted on top. However, many other designs are possible. (See, for example, the photo of a lying and standing wood wheelchair.)

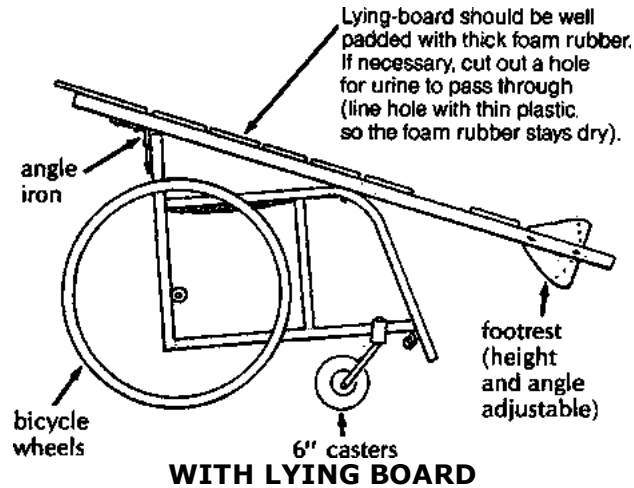

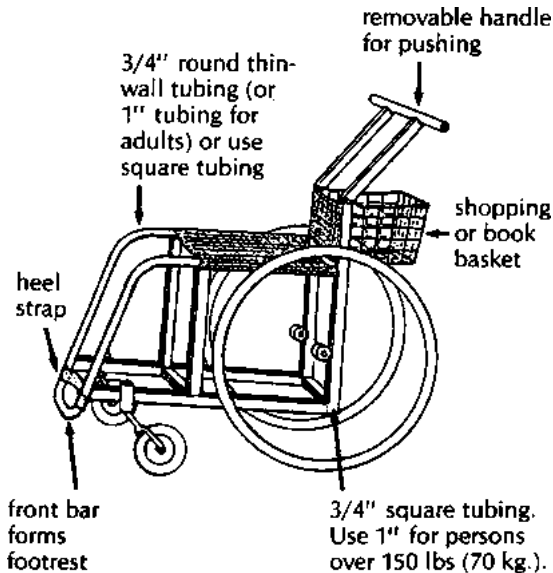

WITHOUT LYING BOARD and with other additions

**For tall persons, place the casters farther from the big wheels to help prevent tipping
THE LYING BOARD**

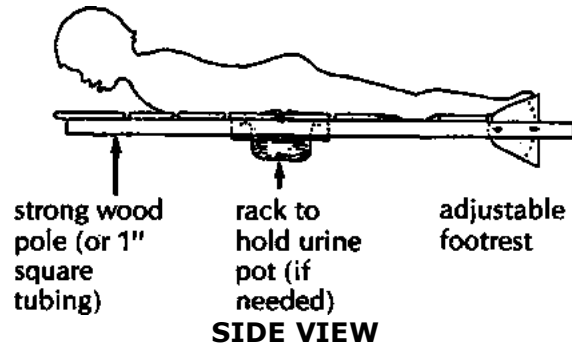

Attach thin wood or plywood boards with small screws so that they can be easily adjusted to leave open spaces under bony parts or sores

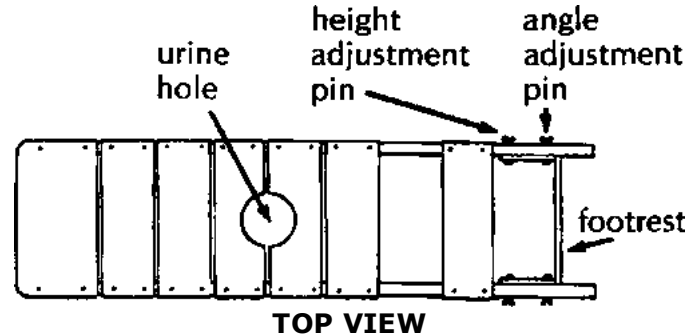

Make the board and wheelchair just a little wider than the child's hips.

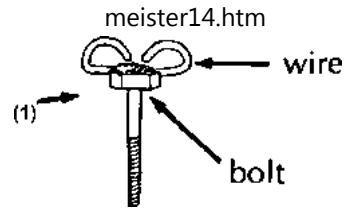

Figure

The board attaches to the chair with angle irons or wing bolts (1). You can make wing bolts by brazing a stiff bent wire to a bolt.

FOOTREST

Use thin wood or plywood. (Pad sides and bottom well to prevent sores. Examine feet daily.)

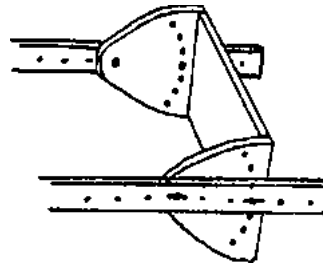

Figure

REMOVABLE HANDLE

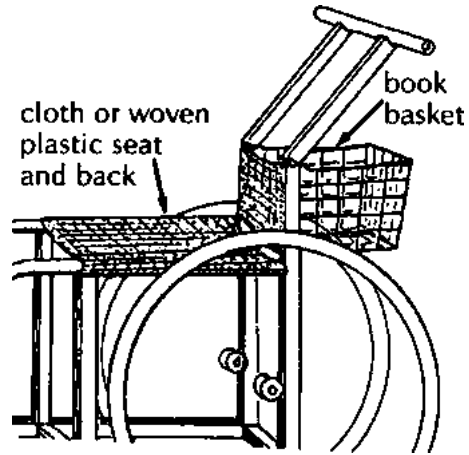

Figure

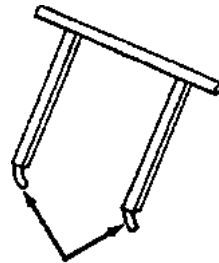

pieces that
fit into
side tubes
Figure

FRONT CASTER WHEEL

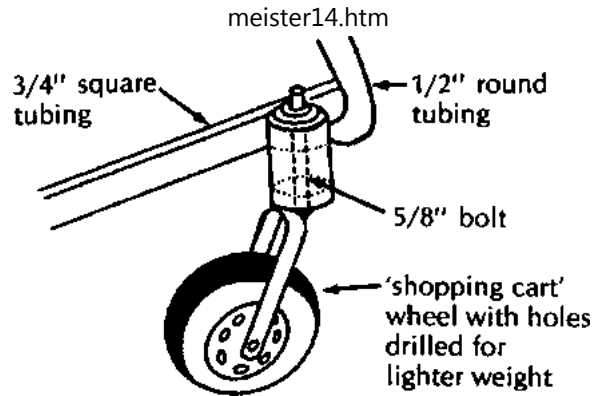

Figure

You should now have enough information to make a wheelchair with a lying board without step-by-step instructions. Adapt it, and make it the size to fit the child that needs it.

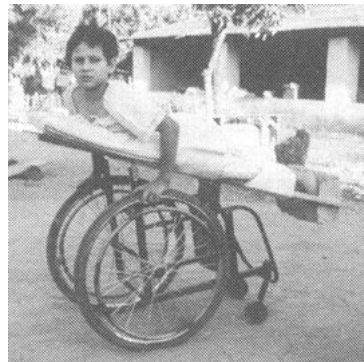

Wheelchair with lying board. A wide strap holds the child in place (but take care it does not press on sores).



Wheelchair without lying board.

A variation of the wheelchair with lying board adapted for a paraplegic child with both contractures and pressure sores of his hips and knees. Urine is collected in a plastic container. The wheelchair seat has been converted into a basket.

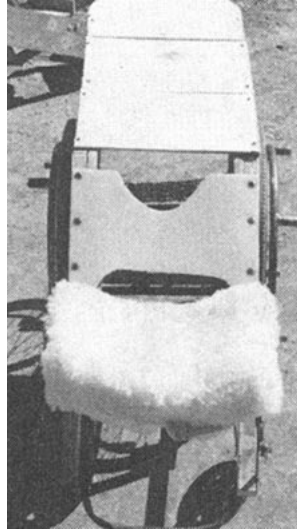

Figure



Figure



Figure

CAUTION: Remember that a child who has some pressure sores can easily get new ones. Be sure the child lies and sits so that there is little or no pressure over bony places. **Examine her whole body at least once a day and try to keep her dry.**

CP PLYWOOD FRAME WHEELCHAIR

This can be easily built by someone with basic carpentry and welding skills. (Cost in Mexico using new materials is about US \$40.00.) Positioning aids (head rest, hip pads, etc.) can be easily added. The chair can be designed to meet a child's particular needs. For example, if the child sits well without extra support, the tops of the side pieces can be removed to allow more freedom of movement.

A plywood frame is a low-cost alternative to metal. However, if not made well, or if left out in the rain, the chair may weaken and the plywood can split. As with any wheelchair, it must be protected from misuse, periodically examined for weaknesses, and promptly repaired.



Figure

For active children the wheelchair can be strengthened by reinforcing all joints and by adding strong hubs and axles.

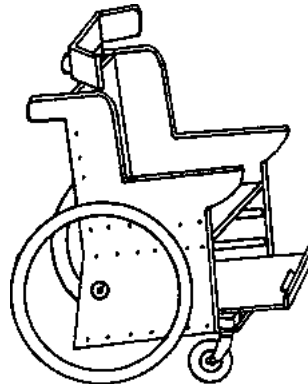

SIMPLE MODEL

HOW TO MAKE YOUR CHAIR

1. Review drawings of chair and adaptive equipment.
2. Cut out the two side pieces to the same shape; sand with sandpaper.
3. Cut out back support, seat, and bottom piece of chair; sand with sandpaper.
4. Screw or nail seat and bottom piece to back piece.
5. Screw or nail side pieces to seat, bottom, and back.
6. Check that all pieces are lined up straight. Then add glue and more screws or nails for strength.
7. Cut out footrest and guide brackets for footrest.
8. Screw or nail guide brackets to side pieces under seat.
9. Bolt front casters to chair and assemble rear axle tube.
10. Drill holes in side pieces for axle tube; mount tube and rear wheel.
11. Let glue dry 1 to 2 days; check for strength of all wood joints.

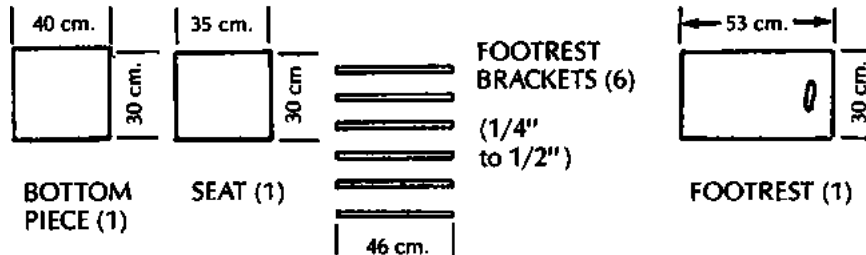
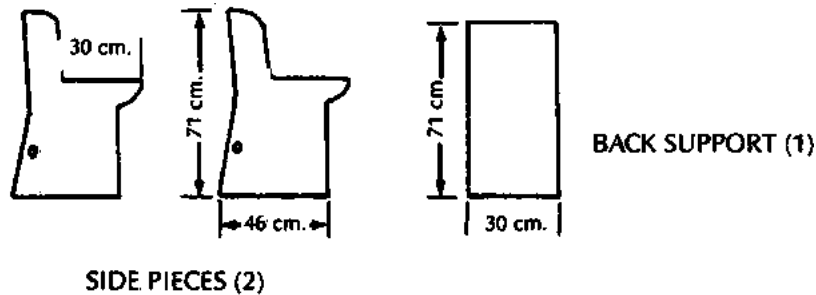

These measurements are for a 4-to-8-year-old child.

MATERIALS NEEDED

- 3/8" plywood (1 sheet)
- 20" bicycle wheels (2)
- small caster wheels (2)
- 1/2 steel tube (66 cm. long)
- wood glue
- sandpaper
- screws

- nails
- 1/2" by 1/4" wood strips (6 x 46 cm. long)

A plywood wheelchair with many adaptations

This wheelchair has a variety of additions sometimes needed for a small child who has poor body control, head control, and urine or bowel control. The head support and armrests fit into wooden holders and can be easily removed. A lap table can be easily added. Holes can be cut out for chest and hip straps for extra support.

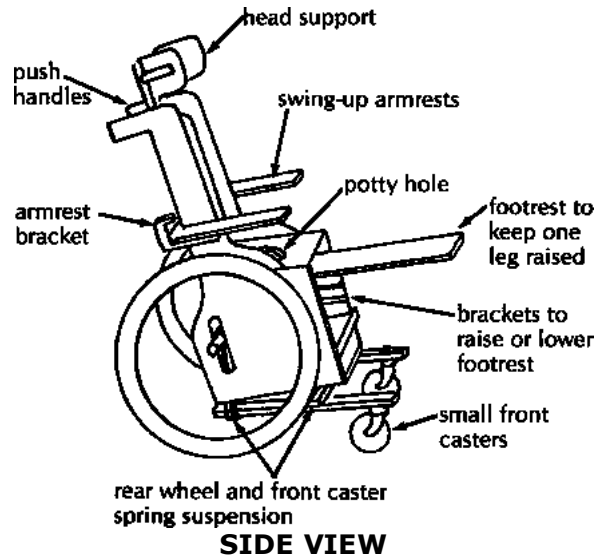

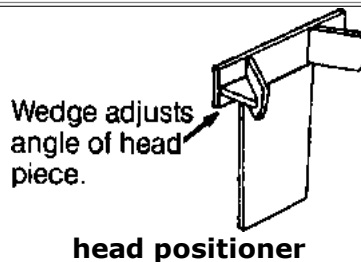
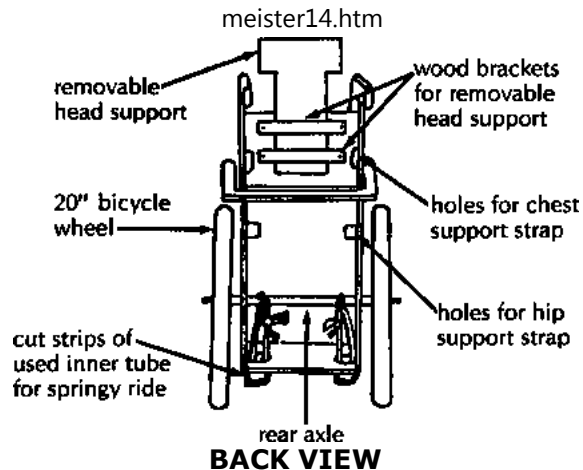

Important: Pad it well
Bottom slides into slot on rear of chair

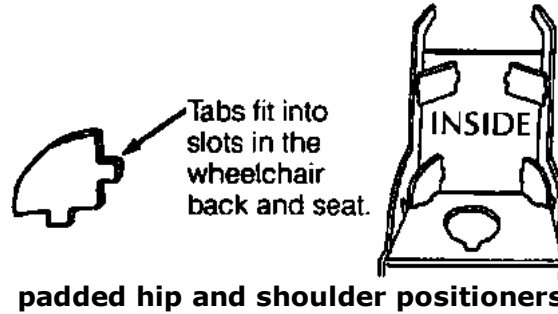
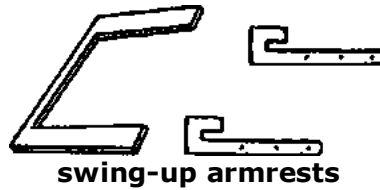

Tree branch holds stiff legs apart.

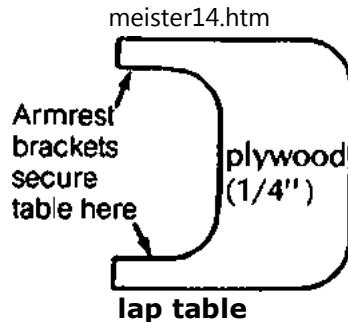

The lap table should be cut to fit closely around the wheelchair sides. The same wooden brackets for the armrests keep this table in place. If the table wobbles, you can use small slats to strengthen the table. If the knee separator is made a bit higher, the table can rest on top of it and prevent any dips.

SPRINGS FOR ALL 4 WHEELS

This plywood wheelchair has a springy ride. Old inner tube rubber strips connect the rear wheel axle to the wood strips holding the front caster wheels. These wooden strips should be strong enough to withstand the springy motion of the front casters.

Special cut-away slots allow the rear axle to move up and down freely. Other cut-away slots in the bottom of the wheelchair allow for the inner tube strips to be wrapped around the wooden caster strips. The tighter the inner tube strips are wrapped, the less bouncy the ride becomes.

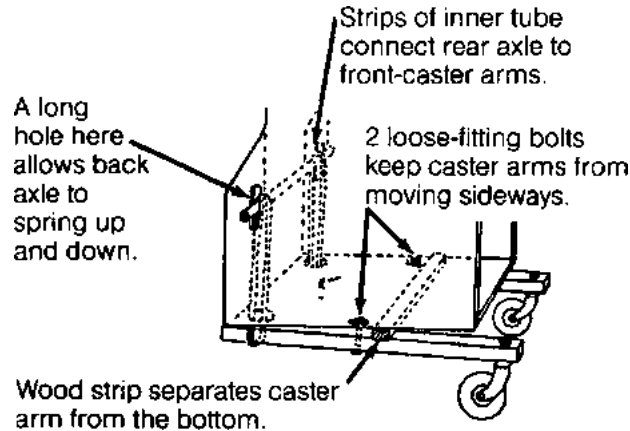

Figure

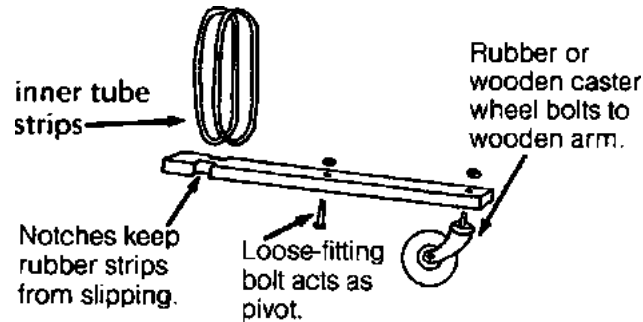

Figure

WHIRLWIND STEEL TUBE WHEELCHAIR

The whirlwind (ATI-Hotchkiss) wheelchair is a very strong lightweight folding chair. On

rough ground it rides more easily and lasts longer than more costly factory-made chairs. If it breaks, it can be fixed by the neighborhood metalworker. It is narrow and helps the rider to move about crowded rooms.

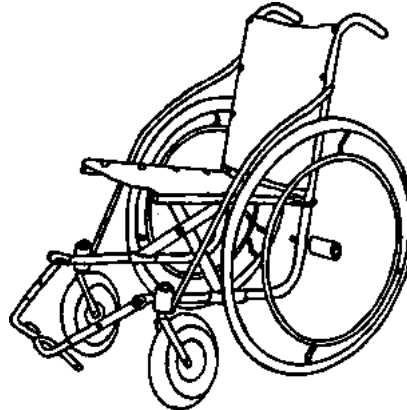

Figure

The frame of this chair is made of thin-wall steel tubing that is easy to shape by someone with basic mechanical and welding skills. It can be built in about 4 days in a small metalworking shop. More than 10 groups of disabled mechanics throughout Latin America are building this wheelchair - often at less than a quarter the cost of imported wheelchairs.

Most materials for this chair can be obtained locally. It uses standard 24" (or 26") bicycle wheels. The extra strong hubs use standard small machinery bearings (which can often be obtained used for free or at low cost from electric machinery repair shops). The axles are 5/8" (1.6 cm.) steel bolts. Seating is canvas (heavy cloth). If the small front wheels are not available, you can make them out of wood.

The curved fender bar that follows the shape of the tire makes transfers easier. The lightweight folding footrests are narrow at the front, for moving more easily in crowded spaces.

Plans for making hubs, casters, and brakes are on the next page. Complete plans for making this wheelchair are in the book *Independence Through Mobility*. The book is essential for anyone planning to build this chair.



Model with wooden front wheels

MATERIALS NEEDED

- thin-wall tubing (from 1/2" to 1 1/4")
- thick-wall tubing (5/8" inside diameter)
- thick canvas or nylon cloth (2 meters)
- square tubing (thin-wall)
- bicycle rims and spokes (24" or 26" diameter)
- caster wheels (2)
- used sealed bearings (8)

- re-bar steel (3/8" round)
 - flat bar steel (1/16" × 3/8")
 - axle bolts (4) (5/8" × 5")
 - washers (4) (1" diameter, 16 upholstery)
 - screws (8 upholstery)
 - machine screws (8) (1/4" × 1 1/2")
 - paint or chroming chemicals
 - bronze welding rod, flux
- bicycle tires and inner tubes (24")

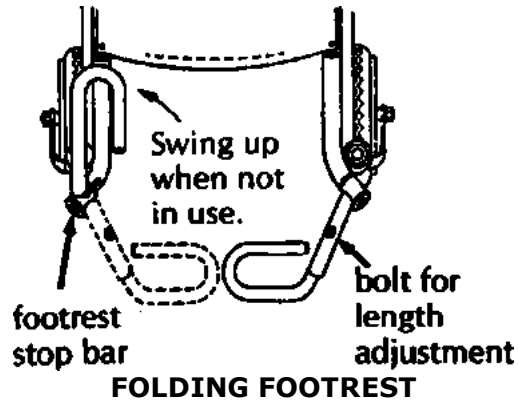

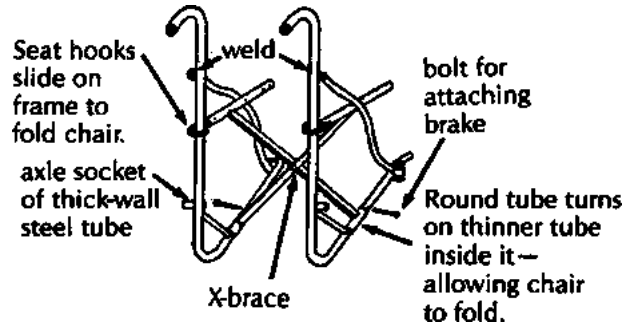

X-BRACE

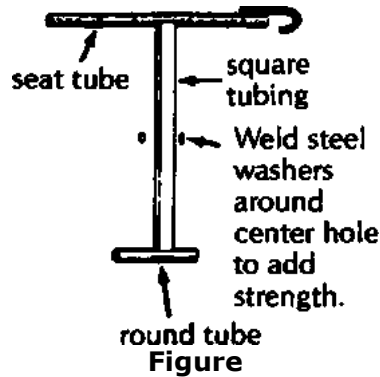

Figure

DETAILS OF HOW TO MAKE WHEELCHAIR PARTS (can be used with many wheelchair designs)



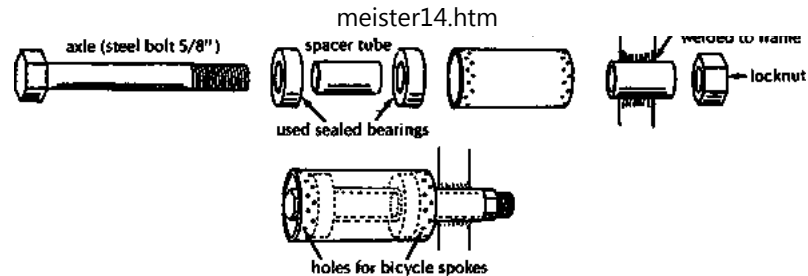

HEAVY-DUTY WHEEL HUBS

- A thick bolt should fit tightly inside bearing.
- Bearings should fit tightly inside outer steel tube.
- Carefully mark and drill the outer steel tube for spoke holes.
- Spacer tube fits over axle bolt and holds bearings against spoke heads.

Note: Used sealed bearings with a 5/8" inner diameter can often be obtained free or at low cost from electrical tool and appliance repair shops. These used bearings often last longer than standard wheelchair bearings.

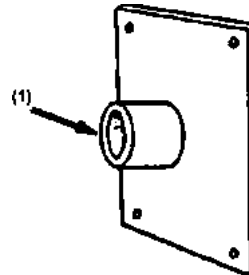

Figure

To attach the heavy-duty hub to a wood chair, you can weld the thick-wall tube to a metal plate

(1).

The bigger the plate is the stronger the mount.

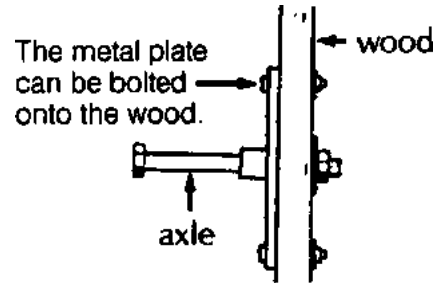

Figure

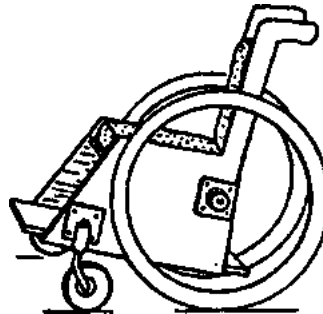

Figure

CASTER FORK AND HUBS

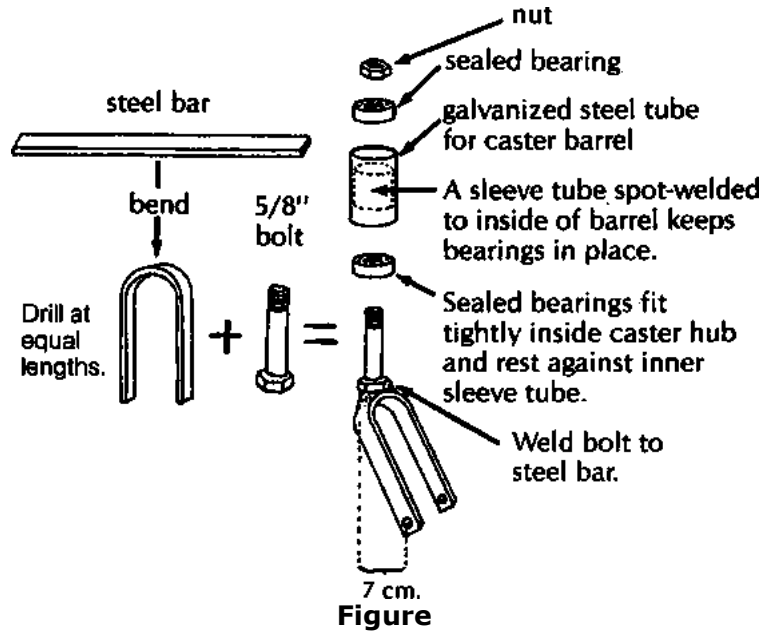

Mount the castor axle at least 7 cm. behind bolt. This help prevent "flutter" at higher speeds.

BRAKES

Castor axle fits tightly inside bearings.

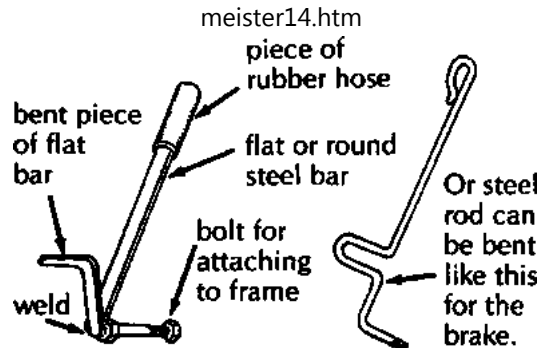

Figure

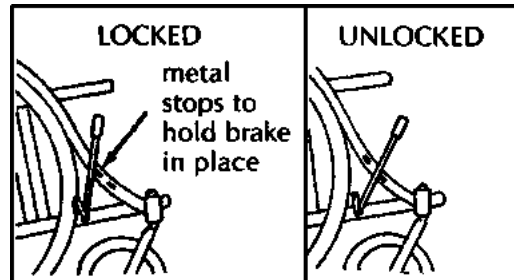

Figure

SEAT AND BACK MADE OF CANVAS (strong cloth)

Cut canvas twice as wide as seat or back, allowing 4 cm. extra on sides (for seams) and at least 20 cm. longer on length.

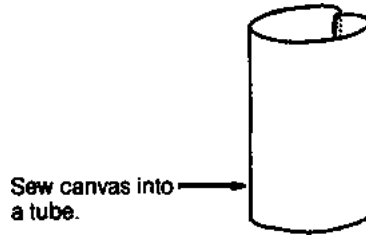

Figure

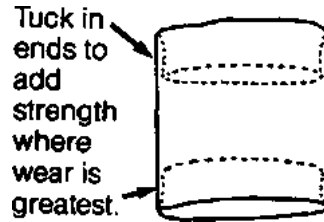

Figure

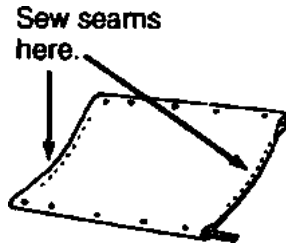

Figure

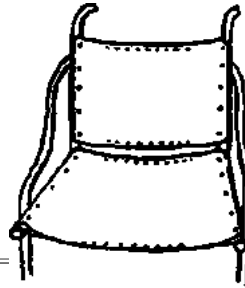

Examples of locally made wheelchairs **Figure**

CP Drill holes and screw rods to frame.

CAUTION: Measure carefully. On a folding chair, the width of the seat and back control the width of the chair. **File the plywood wheelchair, with the armrest in place (1) and swung back (2).**



Figure

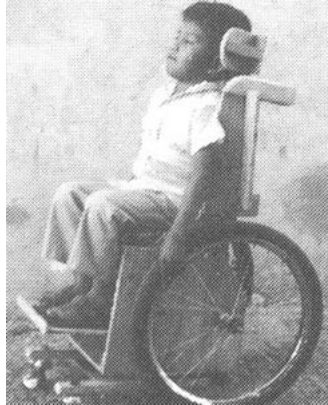

Figure

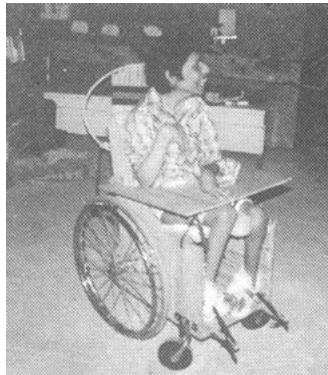

A plywood wheelchair for a child with cerebral palsy with inner tube stretching aids to gently pull his feet and straighten his severe knee contractures.



A bamboo hand-powered tricycle made at Viklang Kendra (People's Village), Allahabad, India.



A wheelchair made completely of paper, including the wheels. Paper is glued together using rice flour in water (Zimbabwe).



A wood design of the wheelchair, two AHRTAG wheelchairs, and a 'trolley' made from half of a plastic bucket and wood wheels.

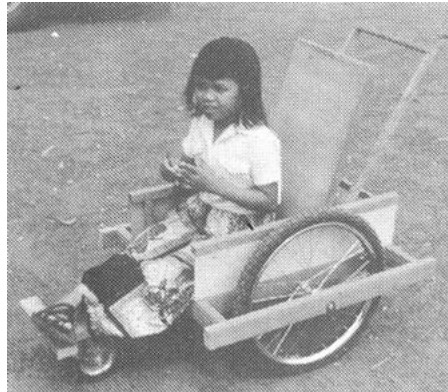

A wood wheelchair in Thailand. The bicycle wheel axles are supported on both sides to keep them from bending.

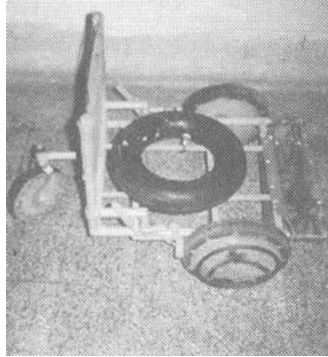

A metal frame, wood wheel 'trolley' in Bangladesh. The rubber tube serves as a cushion and also as a toilet seat.



This trolley, also from Bangladesh, uses a cushion made of coconut fiber covered with rubber.

Chapter 67: Artificial Legs

Artificial legs can be (and often are) made at home or in village shops. How well they

work and how natural they look depend on many things, including costs, skills, and materials available.

BELOW THE KNEE

The most common leg amputation is below the knee, A leg that has been amputated halfway between the knee and ankle works best for walking with an artificial *limb*. Here are some examples of artificial limbs, from simple to more complex.

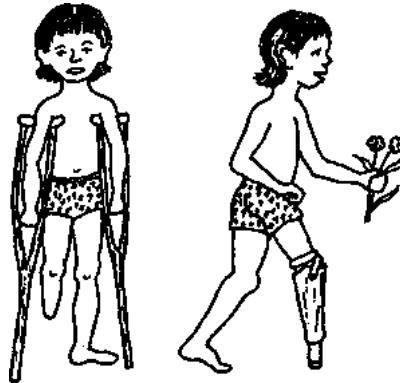

Even a simple artificial limb can make a big difference.

WITH THE KNEE BENT

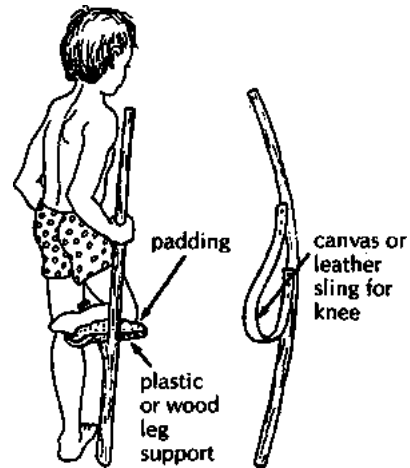

HAND-HELD POLE LEGS

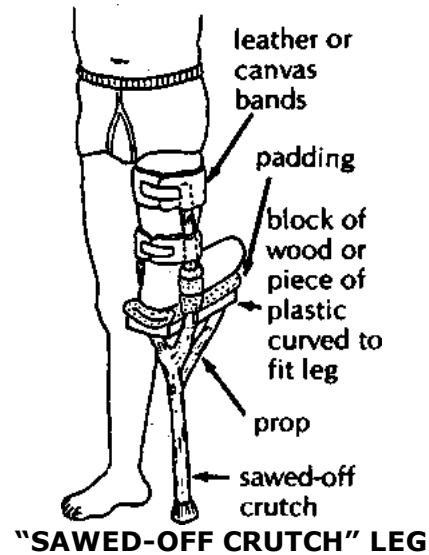

CAUTION: Limbs like these 3 are quick and easy to make, but **they cause knee contractures. As a result, the knee cannot be easily straightened** to fit a better, more useful limb. **Bent-knee limbs should only be for temporary or emergency use. Do exercises every day** to keep the knee straight and strong.

WITH THE KNEE STRAIGHT

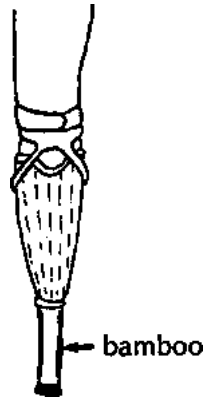

BAMBOO AND PLASTER LEG

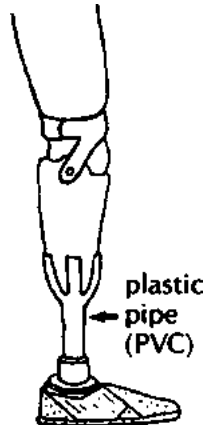

PLASTIC PIPE LEG WITH FOOT

POSITIONS FOR FITTING A LIMB



BAD will only work with a bent-knee limb



DIFFICULT knee does not straighten fully



GOOD knee straightens completely

Exercises to strengthen and straighten the leg

From the time a leg has been amputated until a limb is fitted, daily exercises are needed to keep the hip and knee *muscles* strong and to avoid contractures. If weakness and contractures already exist, these should be corrected as much as possible before a limb is fitted. Exercises are discussed.

AVOID CONTRACTURES



Contractures here and here (1) need to be straightened before a standard limb can be fitted.

How soon can an artificial limb be fitted?

Children born without a foot or part of a leg (or legs) can be fitted with an artificial limb as early as 10 or 12 months of age.

A child whose foot has been cut off can and should be fitted with a temporary limb as soon as the wound has healed. However, be very careful not to injure or put any pressure on

the new scars or end of the stump.



Figure

Note: On a very young or fat child, it may be difficult to fasten the limb firmly to the knee (the bones may not stick out enough). Straps to a waistband and even over the shoulder may be needed.

Temporary limbs - when to use them and why

Because a stump usually shrinks and changes shape in the first weeks after a limb is fitted, it is often wise first to fit a low-cost, temporary limb. This is especially true if the amputation is new or the stump is swollen. A better-looking, more permanent limb can be made after 4 to 6 weeks, or when swelling is gone.

Preparing the stump

In the first weeks or months after an amputation, the stump tends to swell up. The

swelling may in time lead to a club-shaped, deformed stump, which is difficult to fit with an artificial limb. For this reason, it is important to wrap the stump with elastic bandage from the time the leg is cut off until a limb is fitted, or at least until there is no more sign of swelling of swelling.

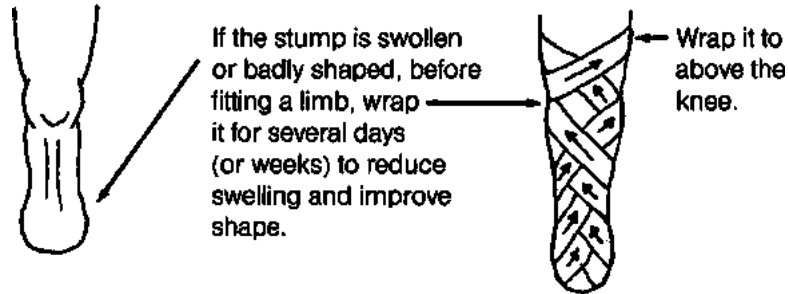

BAD SHAPE



GOOD SHAPE

NOTE: When the person is not wearing the artificial leg, he should also wear an elastic

bandage to control the stump shape

The art of limb making

Making artificial limbs that fit and work well is both a science and an art. If possible, try to learn from a skilled limb maker. 'On-the-job' training for even a few days can make a big difference.

Before starting to make an artificial limb, **STUDY THE PERSON'S LEG.**

A good fit of the socket on the stump and at the knee is one of the most important-and difficult - parts of limb making. It helps to have an understanding of the bones and muscles in the leg.

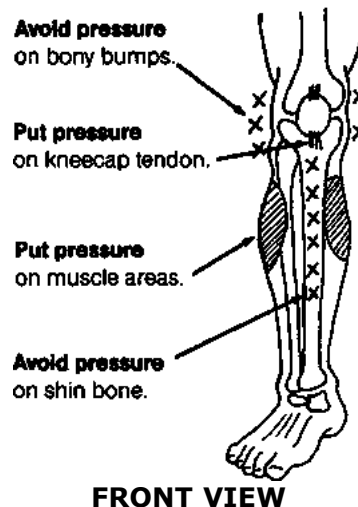

A GOOD SOCKET,

- 
- **does not press** on bony bumps just under the skin.
 - **presses** against muscles.
 - **presses** in firmly just below the kneecap. (The main weight bearing is here.)
 - **does not press** over shin bone.
 - **leaves enough space** at stump tip so that tip will not be injured if the stump settles a little deeper into the socket.

SIDE VIEW

Before beginning, study the person's knee and stump carefully. Note the positions of the kneecap, the bony bumps on the sides of the knee, and the shin bone.

MEASUREMENTS YOU MAY NEED FOR A BELOW-KNEE LIMB

(Copy this chart and use it to record your measurements.)

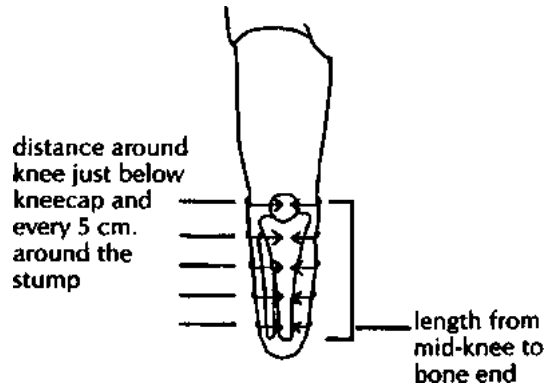

Figure

Note: For the plaster and bamboo limb, only lengthwise measurements are needed.

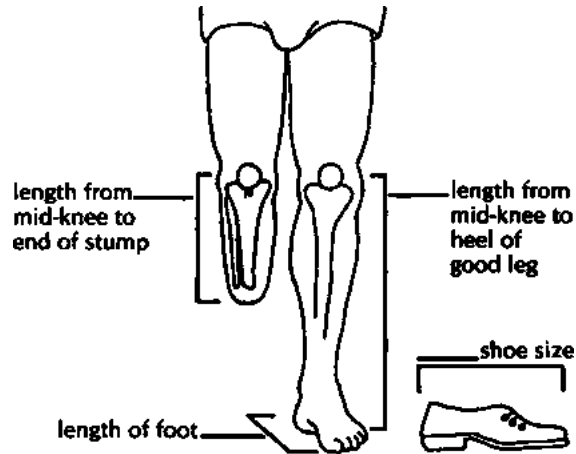

Figure

Note: The artificial limb should be the same length or just a little shorter than the other leg.

PLASTER AND BAMBOO BELOW-KNEE ARTIFICIAL LEG

This simple, low-cost leg was developed for refugee amputees in Thailand by Operation Handicap Internationale. It is most useful as a temporary limb for learning to walk. However, if the inner (plaster) part of the socket is made with waterproof glue, or is protected from getting wet, the leg can last for a long time.



A village rehabilitation worker fits a young man with a bamboo limb. (PROJIMO)

Steps for making the plaster socket

1. Make a thick 'cup' or 'cap' of sponge or folded cloth and tape it over the end of the stump (to give it a little extra length).



Figure

2. Put a thick, tight-fitting stocking-without seams if possible - over the stump and knee. (Several thin layers of stocking can be used instead of a thick one.)



Pull tight
to avoid
wrinkles.

Figure

Putting holes near the top of the stocking makes it easy for the child to pull it up tight against the skin while the cast is put on.



Figure

3. Put a thin plastic bag over the stocking.

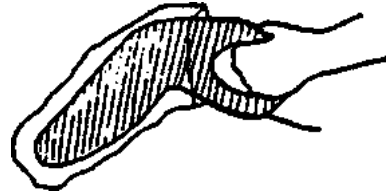

Figure

4. Put a thin cotton stocking or stockinette over the plastic bag and also pull tight to avoid wrinkles.

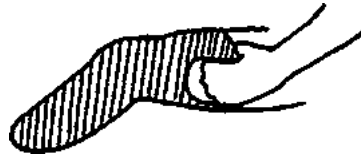

Figure



Figure

Note: If you do not have a stocking, you can mold the socket directly on the stump. Shave any hair off the stump and cover it with vegetable oil (for example, coconut or palm oil).

5. With the stocking stretched tight, mark the important places with a 'grease pencil'. The pencil marks will 'print' onto the inside of the plaster cast when it is removed.

Mark all these places:

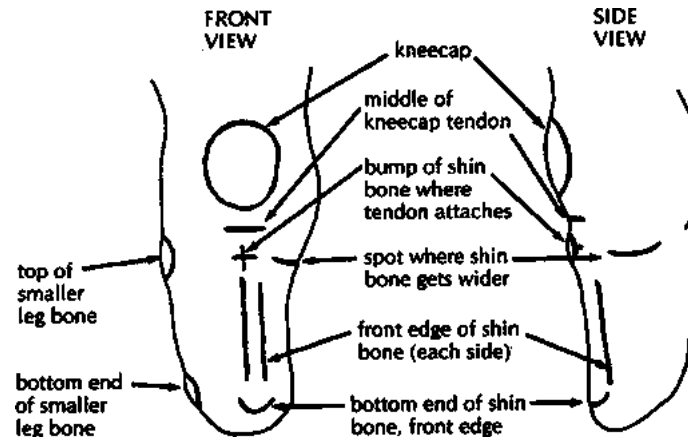

Figure

6. Wrap the stump and knee with plaster bandage. Be very careful to put the bandage on evenly and smoothly. (Elastic plaster bandage works best, but is very costly. To reduce costs you can make your own plaster bandages for casting).

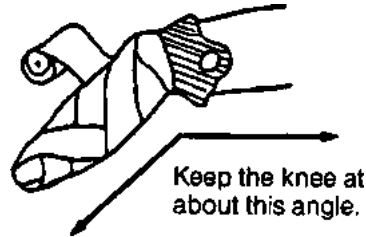

Cast the knee with the stump slightly bent

MAKING THE PLASTER WATER-RESISTANT

The plaster cast of the stump will become the inner layer of the socket of the bamboo limb. So it should be strong and waterproof. To make the cast stronger and water-resistant, wet the plaster bandage with glue instead of water

Use a water-base glue that is water-resistant when it dries



Figure

Note: If the plaster cast is to be used only as a mold for making a leather or resin socket, use water, not glue.

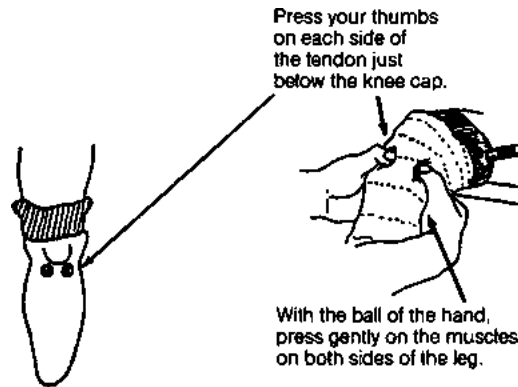
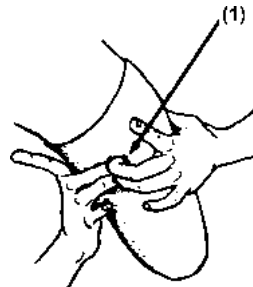
7. As the plaster dries, hold the stump firmly below the knee.**FRONT VIEW****BACK VIEW**

With the 2 middle fingers of each hand (1), press into the hollow behind the knee.

Hold the stump like this until the plaster is hard enough hold the shape.

8. When the cast becomes hard, mark where to cut the top edge (see below).

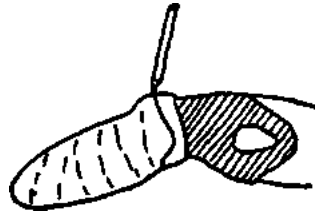

SIDE VIEW



BACK VIEW

9. To remove the cast, roll the stocking over it. Put your hands over the pressure points (as shown above). Have the child wiggle the stump as you gently pull off the cast.

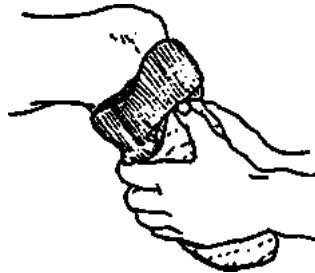

Figure

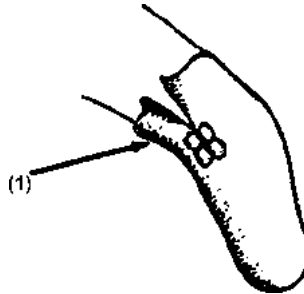

Figure

It may be necessary to cut the cast behind the knee, like this (1), to get it off.

10. Cut the cast along the line you drew.

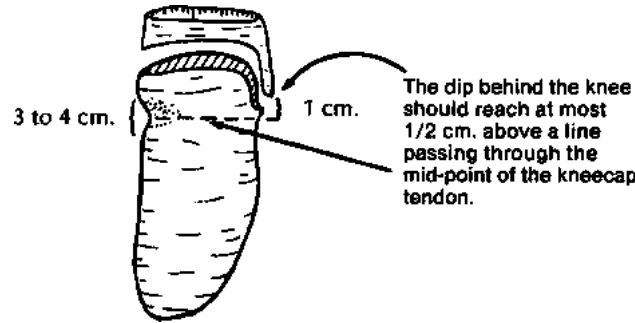

Figure

Preparing the bamboo post

1. Select a piece of strong, green bamboo a little longer than the good leg from the knee to heel.

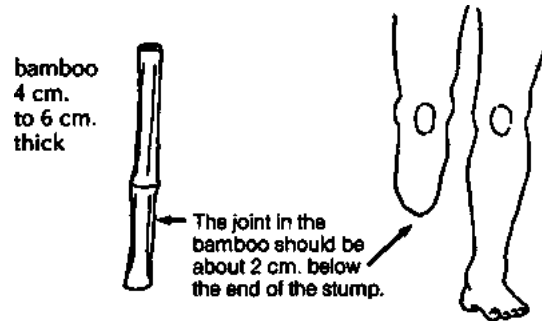

Figure

2. Split the bamboo to a little below the level of the stump end. Split into thin strips-each

about 3/4 cm. wide.

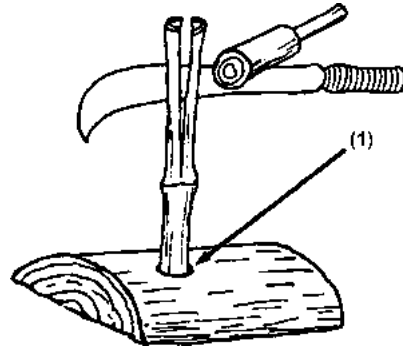

Figure

Hold the post up firmly (1) in a vise or a log with a hole in it - or however you can.

3. Remove the softer inner layer from each of the thin strips.



Figure

4. Spread the bamboo, strips around the plaster socket.

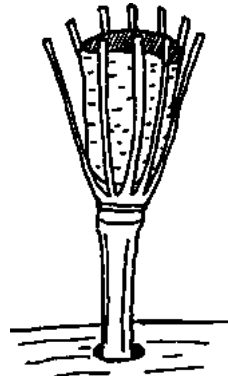

Figure

5. Position the socket as correctly as you can. Then, with a thin wire, wrap the bamboo tightly against the socket.

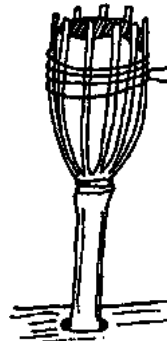

Figure

6. Put the limb on the stump and have the child stand on it. Check the length. If necessary,

cut some off the post.

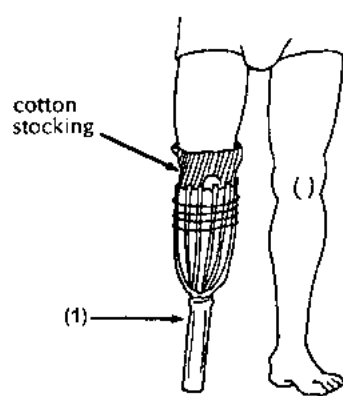

Figure

Make sure the post is straight or at the same angle as the other leg (1). If not, loosen the wire and re-adjust until you get it right.

Note: If child uses a shoe or sandal, be sure to have her wear it when measuring the height of the limb.

7. After trimming the tops of the bamboo strips, cover the outside of the socket with several layers of glue, sawdust, and gauze bandage:

- **Brush on one layer of glue.**
- **Press sawdust on the glue (with gloves).**
- **Wrap tightly with gauze bandage. Let it dry.**
- **Repeat 5 or 6 times.**

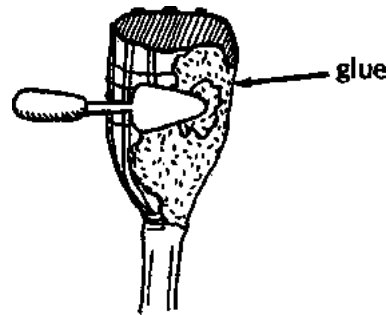

Figure

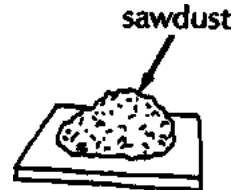

Figure

8. Smooth the outside of the socket with sandpaper. Also smooth and round the inner edges at the top.

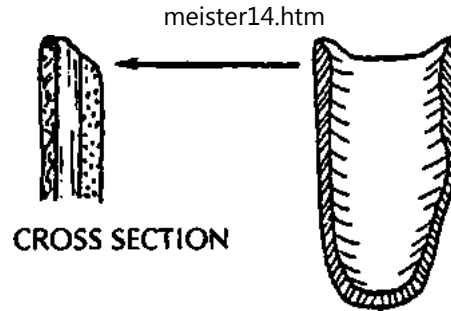

Figure

9. Make a 'cuff' to hold the limb on. (If attached correctly, it should also help keep the knee from over-straightening.)

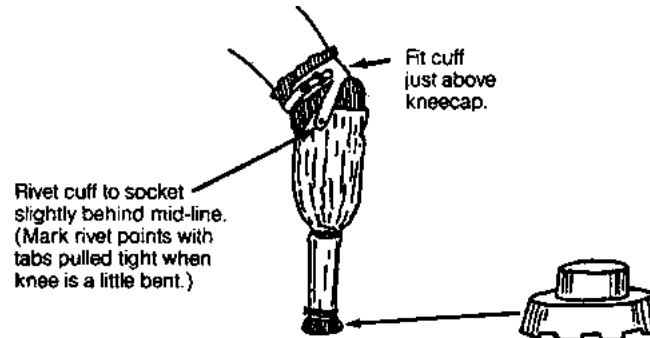

Figure

10. Make a rubber 'heel' - a piece of thick truck tire works well. If you can, cut the tire so that a 'plug' fits inside the bamboo. Cut off bamboo as much as the heel is thick. (Be sure to allow for height of sandal or shoe on other foot.)

Design for the knee cuff

Use strong leather and line it on inside with soft smooth leather. It should be a few cm. longer than the distance around the knee.

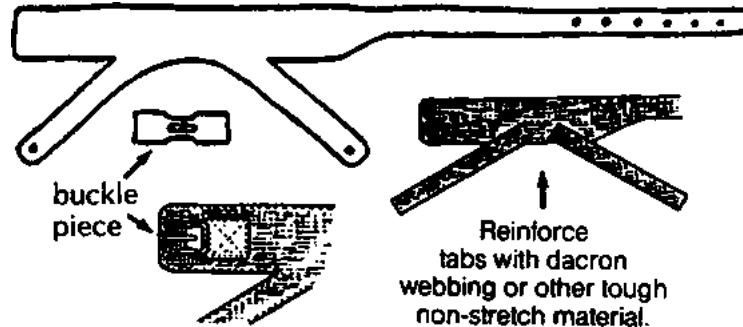

Figure

Glue layers of leather and webbing together with rubber cement and sew at edges.

11. Have the child stand and walk on the limb for several minutes. Then remove it and look for sore spots on the child's skin, or signs of too much pressure. Check especially over bony spots. An area that looks pale when the limb is removed and then turns red or dark, is a sign of too much pressure.



Figure

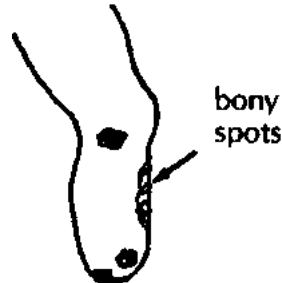

Figure

12. Scrape shallow pits into the socket from the inside, at the points where it presses over bones. You may also need to build up around the area where pressure occurs.

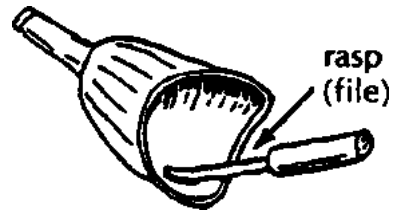

Figure

(To help you find the right points, it helps to have marked 'bony spots' before casting. They will then be 'printed' inside the socket.)

If stump presses on bottom of socket, you may need to build up

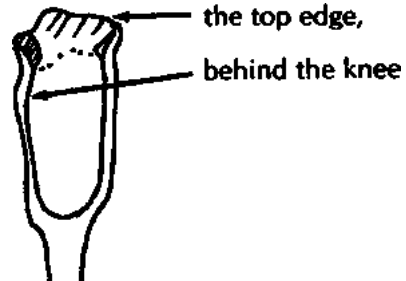

SIDE VIEW CROSS SECTION

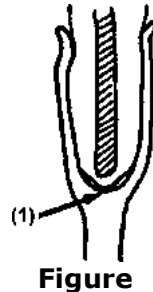
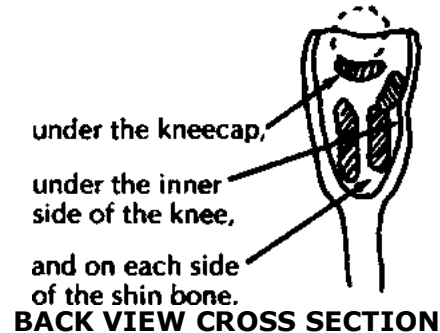

If socket presses on the end of the bone, scrape out a hollow here (1).

To build up these spots, dig a few pits into the socket surface so new material will grip better. Fill with a paste of fresh plaster mixed with glue.

During the first few weeks of using an artificial limb, the stump becomes smaller, and several changes in limb size may be needed. To save time, use a shorter bamboo post so that the plaster socket can be replaced several times with new, smaller ones.

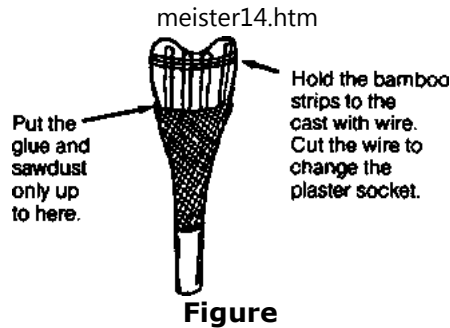

Artificial leg using PVC plastic pipe instead of bamboo

Where plastic PVC water pipe is available, it can be used instead of bamboo. Use a 3 cm. (1% inch) thick-walled PVC.

1. Measure the tube the same as bamboo, and cut it to form 4 strips.

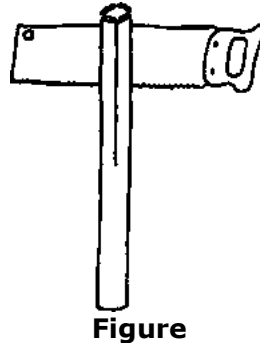

2. Heat the PVC in an oven until it gets a little soft.

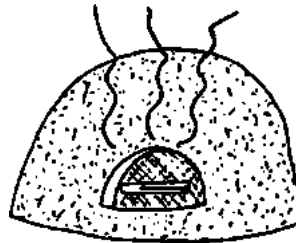

Figure

3. Fit the hot PCV around the socket piece and wrap it tightly with a long strip of cloth or rubber until it cools.

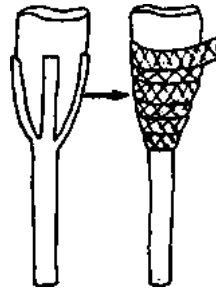

Figure

4. Fasten PVC firmly to socket with wire or rivets (or both). It is best to attach it temporarily with wire and to have the child try it before you fix it permanently



Figure

5. Cover with sawdust and glue, or with resin-base casting bandage (very expensive) or with fiberglass and resin (also expensive).



Figure

Note: For a stronger, water-resistant limb, the socket can also be made with resin-based casting bandage. But this is also expensive.

Adjusting the PVC leg

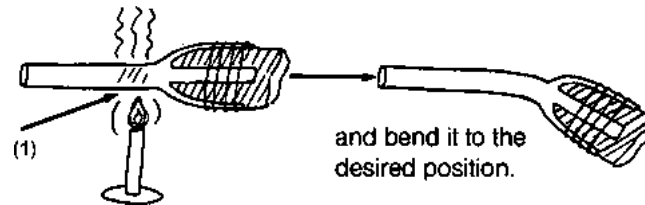
**Figure**

After the child tries on the leg. If the angle seems wrong, you can gently heat the PVC near the stump (1).

Lengthening the PVC leg to allow for growth of the child

1. Cut through PVC pipe.

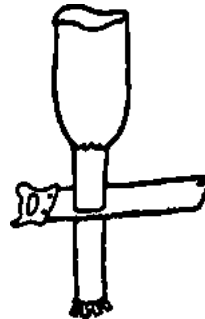
**Figure**

2. Cut a strong hardwood rod or plastic tube that just fits inside the PVC. (1)

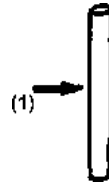
**Figure**

3. Cut a ring of PVC pipe as long as the additional leg length needed. (Make it a little extra long to allow for more growth). (1)
4. Put the wood rod inside the PVC with the new ring of PVC. (2)
5. Drill holes and screw or bolt leg together tightly. (3)

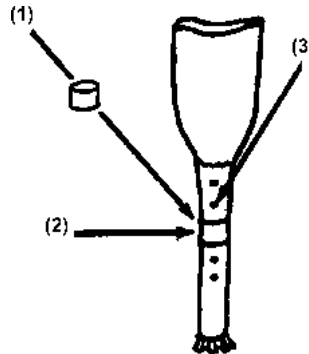
**Figure**

6. When an even longer limb is needed, replace the short ring with a longer one. (1)



Figure

7. If necessary, to make the joint stronger, cut a piece of PVC lengthwise, heat it, put it over the leg tube, and attach it tightly. (1)

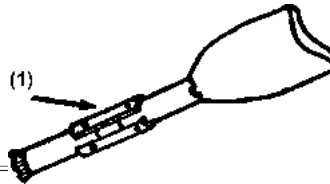

Figure

IMPORTANT: For both below-knee and above-knee limbs, try to line up the limb as well as possible so that its angle is similar to the other leg and 'feels right' when the child stands and steps. Often this requires repeated tries and adjustments. Getting the limb to line up right is the key to successful limb fitting. It helps to learn this from someone skilled at fitting limbs.

ABOVE-KNEE ARTIFICIAL LIMBS

Children who are growing quickly need a low-cost limb that can be easily replaced or lengthened. Small children usually learn to walk well with a straight leg limb that does not have a knee joint.

1. A bamboo or PVC plastic tube above-knee limb can be made in much the same way as for the below-knee limb.

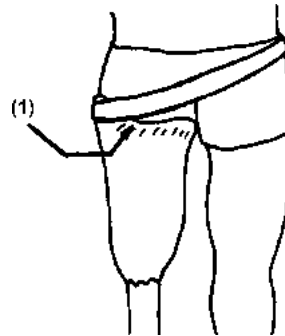

BACK VIEW

The top edge of the socket should be rounded to form a wide lip on the back, where the butt can sit (1). Weight bearing should be on the butt bone and over the entire stump-and not just on the end of the stump.

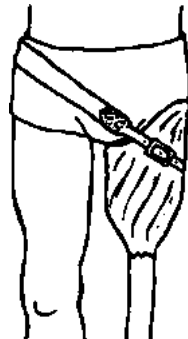

FRONT VIEW



**Figure**

Note: In some countries, thin plastic cuffs the right shape for socket tops can be purchased in different sizes from *orthopedic* suppliers. They can be placed around the leg before casting and can be re-used. Ask for 'prefabricated ischial weight-bearing cuffs'.

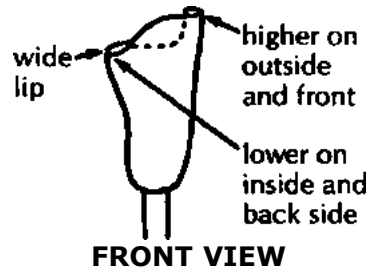
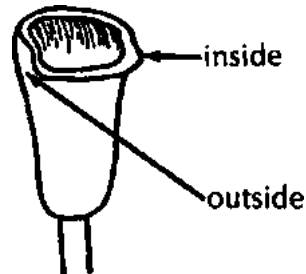
Best shape for top of socket:**FRONT VIEW**

BACK VIEW

square here to allow room for
cord in groin

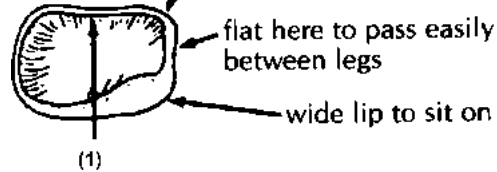

flat here to pass easily
between legs

wide lip to sit on

(1)

TOP VIEW

Make the top of the socket (1) somewhat **square**. You can reshape the wet plaster a little while it is still on the stump, or just after you take it off.

2. A leather and metal rod limb (adapted from *Simple Orthopaedic Aids*).

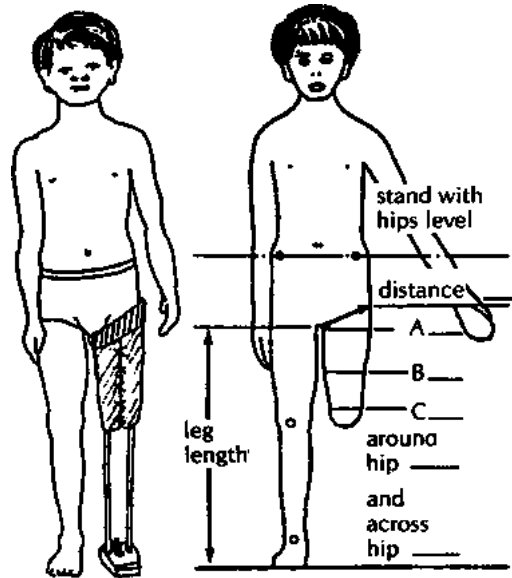

MEASUREMENTS

Note: The socket is open at the bottom of the stump. This makes it cooler than the one above, and also allows for growth.

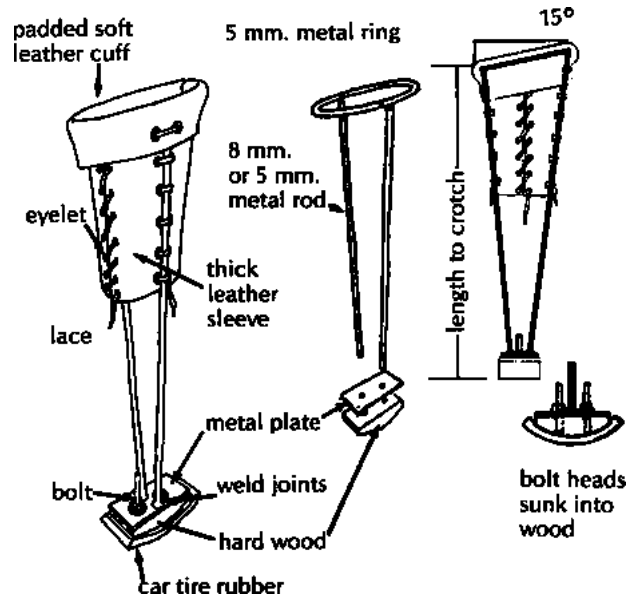

Figure

To make sleeve, draw on paper a design like this based on A, B, and C stump measurements. Then copy onto leather and cut it out.

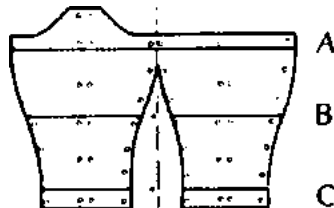

Figure**Above-knee limb with knee joint (for older children and adults)**

Adapted from the OHI Manual: *Simple Above-knee Prosthesis Manufacture*. (Write for the complete manual.)

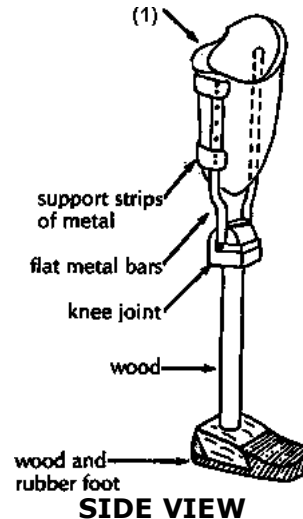

Socket piece of leather (1) (it can also be made of plaster resin, or wood.)

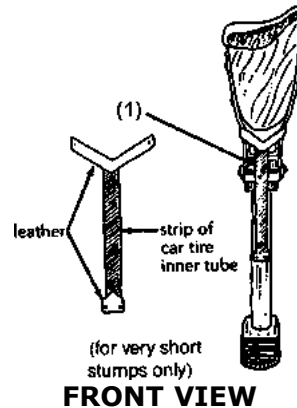

To help keep knee from bending when weight is on it, stretch a piece of rubber across front of knee (1).

Note: This is a simple design for a knee joint. Knee joints that work well are hard to make and you may need to experiment a lot. Perhaps you can re-use a joint from an old limb that is not being used.



Making the knee joint:

1. Mark and round the top of the post.

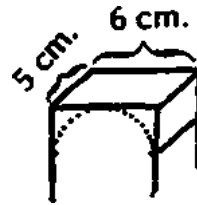

Figure

2. Drill hole at exact center of circle.

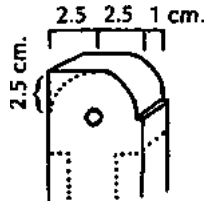

Figure

3. Weld or rivet angle piece at right angle. (Use flat metal bar.)

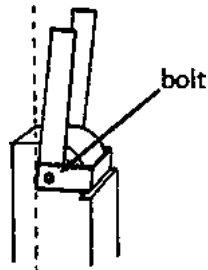

Figure

4. Round back of post.



Figure

5. Drill hole in post and attach bolt with wire (to lock knee straight, when necessary).

6. Ledge prevents knee from bending backward. Small strip of y car tire acts as cushions

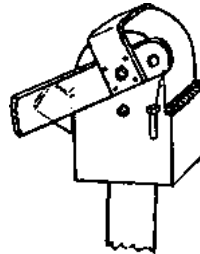

Figure

7. Add an angled piece to allow joint to stop in a squatting position.

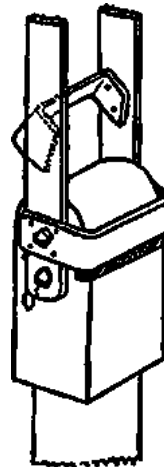

Figure

FEET

Putting feet on artificial legs makes them look better (with shoes, sandals, or boots). Also, the wide base helps prevent the leg from sinking into mud or sand. A well-made, flexible foot can make walking easier. Here are 2 possibilities.

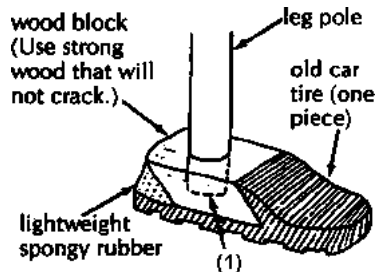

Figure

Note: By putting the pole through the foot (1), if the foot breaks off the person can keep walking.

**Figure**

The sponge rubber over the heel and toe (1) lets the foot bend for smoother walking .

To mount a foot on a plastic PVC tube, use a metal pipe base like this.

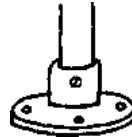
**Figure**

A foot can also be made for a metal-rod leg. Here is one possibility.

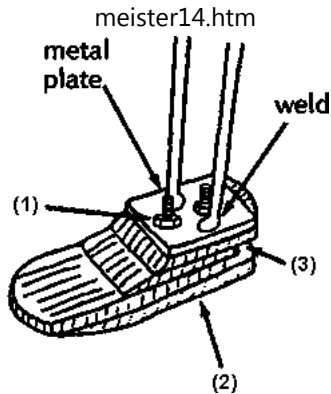

Figure

Bolts should pass through all but last layer of rubber (1).

3 or 4 layers of car tire (2), cut to allow flexibility of toes and heel.

Leave open space above bottom sole (3) for flexible heel.

OTHER WAYS OF MAKING ARTIFICIAL LIMBS

Wooden legs

The oldest, traditional way of making artificial limbs is to make the socket out of wood.

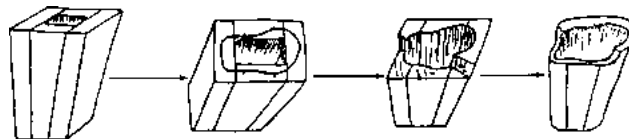

Figure

This is best learned from a skilled craftsperson. Unfortunately, this is a skill that is difficult to learn from a book. A book that describes the method step-by-step is *Manual of Above-Knee Wood Socket Prosthetics* by Miles Anderson, John Bray, and Charles Hennesey. It has gone out of print, but you may still be able to find it. Unfortunately, the methods described are complex and require a lot of special equipment. However, perhaps they could be simplified. (We have not tried this method.)

Leather socket: Self-adjusting prosthesis

This method uses flat metal bars, a wood post, and a thick, firm leather socket. To form the socket, wet leather is stretched over a plaster mold of the stump. Methods are clearly and simply described in *Simple Below-knee Prosthesis Manufacture*.

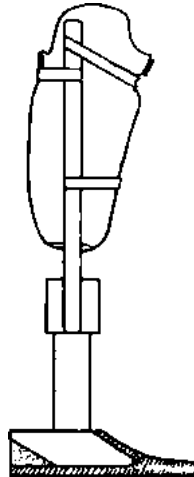

Figure



Figure

A leather socket has several advantages. Leather is available almost everywhere, is more comfortable in hot weather, and can easily be adjusted to the stump as it becomes smaller. Also, leather is soft and easily takes the shape of the stump, and therefore self-corrects molding mistakes.

Stump protectors from old tires

For a child with both legs amputated above the knee, short artificial limbs or even simple 'stump protectors' may allow her to move about easier than long leg limbs.

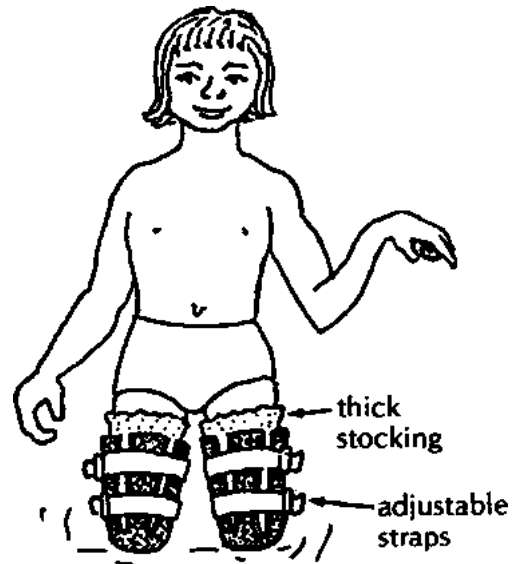

Figure

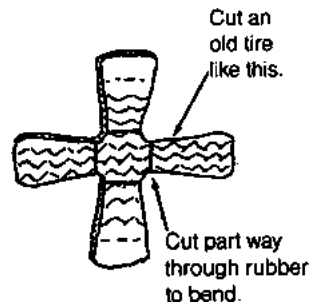

Figure

Jaipur limb

The 'Jaipur limb' was developed in Jaipur, India to meet the need for a limb that would (1) allow working 'barefoot' in rice paddies, (2) look like a real bare foot, (3) bend at the foot in all directions enough so the person can squat easily and walk firmly on uneven ground, and (4) be low cost and quick to make.

The foot is made of wood and sponge rubber and then 'vulcanized' (heat molded) with rubber, using a metal mold. The rubber gives the foot its life-like form and color and makes it strong and waterproof.

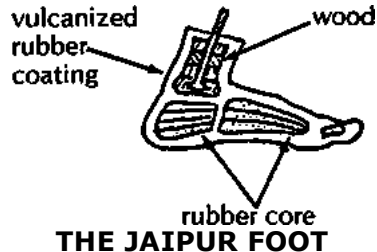

Figure



squatting

The limb is made of SHEET ALUMINUM.

1. Take measurements of normal leg.

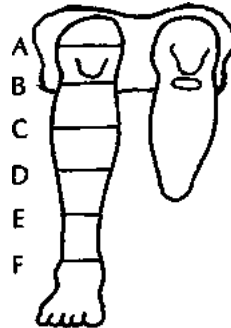

Figure

2. Mark a sheet of aluminum and cut out leg form.

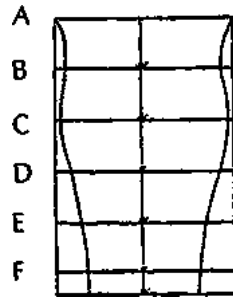

Figure

3. Bend into tube.

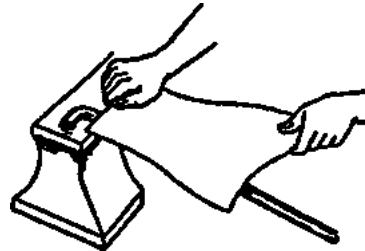

Figure

4. Weld the seam.

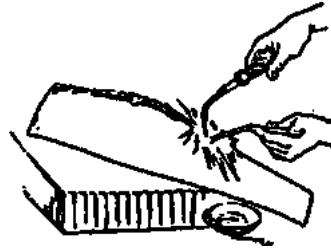

Figure

5. Hammer tube into shape of leg. With repeated tests, fit it to the knee just right.



Figure

6. Attach knee strap and foot.

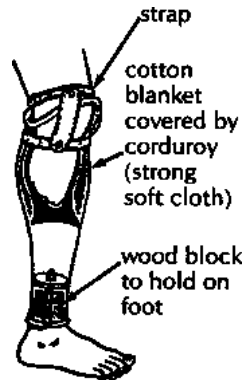

Figure

(Total cost for the below-knee limb can be less than US \$20.)

To make the Jaipur limb requires a lot of skill as well as special equipment. But once a shop is set up and persons trained, the limb can be made at very low cost, and fitted very quickly (one hour from the first measurements until the person walks away on his new limb). For instructions, contact Rehab Centre, SMS Medical College, Jaipur 302004, India.

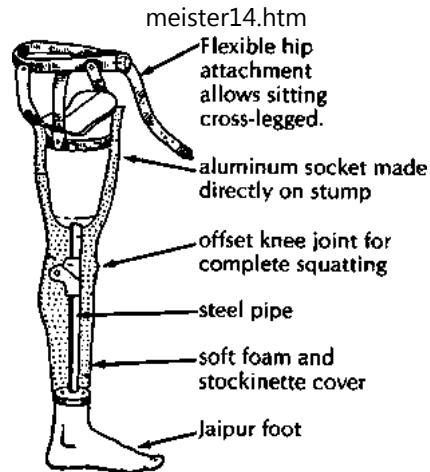

JAIPUR ABOVE-KNEE DESIGN

Ideas for a limb-making shop. Earlier on this book there is a description of the OHI prosthetics shop in Thailand, where amputee workers make the bamboo and above-knee adjustable limbs shown in this chapter.

