

➔ **Nutrition Guidelines (MSF, 1995, 191 p.)**

 **(introduction...)**

 **Preface**

 **Part I: Nutrition Strategies in Emergency Situations**

 **1. Food crises**

 **2. Assessment of the nutritional situation**

 **3. Interventions: ensuring adequate general food availability and accessibility**

 **4. Interventions: selective feeding programmes**

 **5. Evaluation**

 **Part II: Rapid Nutrition Surveys**

 **1. Introduction to anthropometric surveys**

 **2. Anthropometric measurements and indices**

 **3. Sampling methods**

 **4. Analysis, interpretation and recommendations**

 **5. Conclusions**

 **Part III Selective feeding programmes**











 **1. Justification for selective programmes**

 **2. Criteria for admission and discharge to selective feeding programmes**

 **3. Screening and selection**

-  **4. Treatment in a therapeutic feeding centre**
-  **5. Treatment in supplementary feeding programmes**
-  **6. Implementation and management of a feeding centre**
-  **7. Registration and monitoring**
-  **8. Evaluation of feeding programmes**
-  **9. Food management**



 **Annexes**

-  **Annex 1: Rapid assessment of the state of health of displaced populations or refugees (A. Moren - Medical News, No. 1)**
-  **Annex 2: Mid - Upper Arm Circumference (MUAC)**
-  **Annex 3: Nutritional status assessment in adults and adolescents**
-  **Annex 4: Agencies involved in food relief**
-  **Annex 5: Food composition table**
-  **Annex 6: GENERAL RATION: How to calculate the energetic value**
-  **Annex 7: Micronutrient deficiencies**
-  **Annex 8: Food basket monitoring methodology**
-  **Annex 9: Analyzing nutritional survey data**
-  **Annex 10: Drawing of a random number**
-  **Annex 11: Standardization of anthropometric measuring techniques**



-  **Annex 13: Data collection forms**
-  **Annex 14: Selection of food items for selective feeding programmes**
-  **Annex 15: Oral rehydration for severely malnourished children**
-  **Annex 16a: Preparation of High Energy Milk**
-  **Annex 16b: Recipes for porridge for use in therapeutic and wet supplementary feeding programmes**







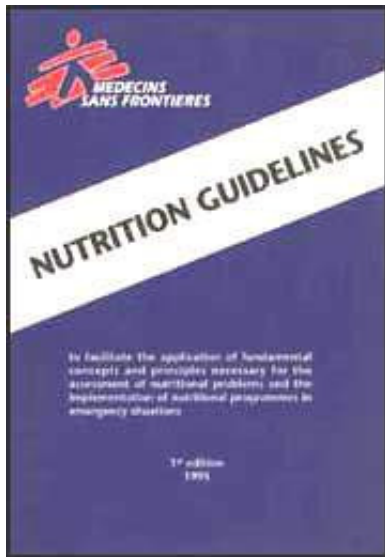

-  **Annex 16c: Recipes for premix for dry ration supplementary feeding programmes**
-  **Annex 17a: Example of a Therapeutic feeding centre**
-  **Annex 17b: example of layout of a <<wet>> supplementary feeding centre**
-  **Annex 17c: Example of a DRY SFP**
-  **Annex 18a: Example of an Attendance register (tfp or SFP)**
-  **Annex 18b: Example of a Nutritional Status Monitoring (SFP)**
-  **Annex 19a: TFP individual monitoring card**
-  **Annex 19b: SFP individual monitoring card**
-  **Annex 19c: Individual card for Supplementary feeding centre**
-  **Annex 19d: Example of an individual card for dry**

-  **blanket SFC**
-  **Annex 20: Feeding programme indicator graphs**
-  **Annex 22: MSF nutrition kits**

Bibliography

[Home](#) > [ar](#).[cn](#).[de](#).[en](#).[es](#).[fr](#).[id](#).[it](#).[ph](#).[po](#).[ru](#).[sw](#)



-  **Nutrition Guidelines (MSF, 1995, 191 p.)**
-  **(introduction...)**
-  **Preface**
-  **Part I: Nutrition Strategies in Emergency Situations**
-  **Part II: Rapid Nutrition Surveys**
-  **Part III Selective feeding programmes**
-  **Annexes**
-  **Bibliography**

To facilitate the application of fundamental concepts and principles necessary for the assessment of nutritional problems and the implementation of nutritional programmer in emergency situation

(c) Mdecins Sans Frontieres - Paris - February 1995

All rights reserved for all countries. No reproduction, translation and adaptation may be done without the prior permission of the Copyright owner.

Nutrition Guidelines

COORDINATED BY (in alphabetic order):

Marleen BOELAERT

Austen DAVIS

Brigitte LE LIN

Marie-Jo MICHELET

Koert RITMEDER

Saskia VAN DER RAM

Fabienne VAUTIER

WITH THE CONTRIBUTION OF (in alphabetic order)

**D. COULOMBIER, M. DUCOS, M. HENKENS, B. PECOUL, M. PHILIPS, J. RIGAL,
E. SONDORP, M-P. SPIELMAN, H. VAN DORPE, R. ZACCHARIAS.**

We would like to thank for their advice and suggestions:

**R. BHATIA, P. BEQUET, D. BITAR, A. BRAND, V. BROWN, M. DEGUERRY, A.
DEVAUX,**

**T. DUSAUCHOIT, F. FERMON, V. GENAILLE, V. GENTIEN, M. GOLDEN, C. GUILLET,
P. HAKEWILL, K. HILDERBRAND, A. HOOGENDOON, P. HUMBLET, N. ISOUDARD,
A. MOREN, H. RITTER B. SHIFFER J. SHOHAM, R. TECK, M. TOOLE, H. YOUNG.**

Editing:

Annie ARBELOT

1st EDITION

[Home](#) > [ar](#).[cn](#).[de](#).[en](#).[es](#).[fr](#).[id](#).[it](#).[ph](#).[po](#).[ru](#).[sw](#)

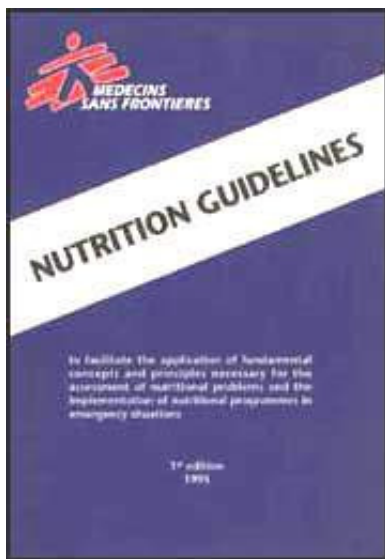
**📖 Nutrition Guidelines (MSF, 1995, 191 p.)**

📄 *(introduction...)*

➔ 📄 **Preface**

📁 **Part I: Nutrition Strategies in Emergency Situations**

📁 **Part II: Rapid Nutrition Surveys**

📁 **Part III Selective feeding programmes**

📁 **Annexes**

📄 **Bibliography**

Preface

This guideline is presented in 3 parts:

- **Nutrition Strategies in Emergency Situations**
- **Rapid Nutrition Surveys**
- **Selective Feeding Programmes**

The purpose of this book is to facilitate the application of fundamental concepts and principles necessary for the assessment of nutritional problems and the

implementation of nutritional programmes to assist populations in emergency situations.

Emergency nutrition interventions are among the most vital components of an emergency relief response. It is an extremely complex subject and the form of response depends on many factors. This guideline is not supposed to be another academic work on nutrition; there are already various excellent reference works available. Nor is it meant to promote a <<recipe book>> approach to the definition of nutrition problems and the implementation/promotion of adequate responses. Every programme in each country or region has its own particularities according to the context (when in doubt, please contact your medical department at headquarters).

All MSF sections collaborated in the production of this work to help standardize nutritional emergency approaches, to allow greater comparison between programmes and over time; and to improve the impact of external reporting. Nevertheless, this guideline leaves enough room for adaption to the local context.

Nutrition should be considered as an integral part of health related issues in emergencies. Nutrition has its place in need assessment, monitoring, information systems, preventive and curative services and public health measures.

We invite field workers working in nutritional programmes to send us their comments on these guidelines. Their comments and suggestions have been essential in the formation of these guidelines and are required for the continuing development of methods and approaches to the problems faced in the field.

Please send your remarks to:

Mdecins Sans Frontieres Belgium / Dpartement Mdical

Rue du Pre, 94- 1090 Brussels

Tel.: (32) 2- 47 47 474 -

Telex: (046) 63607 MSF B -

Fax: (32) 2- 47 47 575

Mdecins Sans Frontieres France / Dpartement Mdical

8, rue Saint-Sabin, 75544 Paris Cedex 11

Tel.: (33) 1- 40 21 29 29 -

Telex: 214630 F -

Fax: (33) 1- 48 06 68 68

Mdecins Sans Frontieres Holland / Medical Dept.

Max Euweplein 40, PO Box 10014 - 1001 EA Amsterdam

Tel.: (31) 20- 520 87 00 -

Telex: (044) 10773 MSF NL -

Fax: (31) 20- 620 51 70



[Home](#) > [ar](#).[cn](#).[de](#).[en](#).[es](#).[fr](#).[id](#).[it](#).[ph](#).[po](#).[ru](#).[sw](#)



Nutrition Guidelines (MSF, 1995, 191 p.)



Part I: Nutrition Strategies in Emergency Situations



1. Food crises

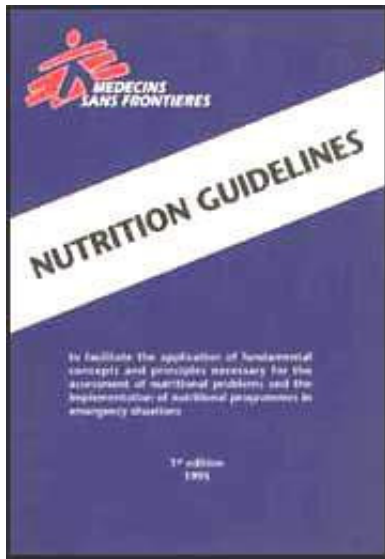

2. **Assessment of the nutritional situation**
3. **Interventions: ensuring adequate general food availability and accessibility**
4. **Interventions: selective feeding programmes**
5. **Evaluation**

Nutrition Guidelines (MSF, 1995, 191 p.)

Part I: Nutrition Strategies in Emergency Situations

1. Food crises

Introduction

In emergency situations, food security is often severely threatened causing increased risk of malnutrition, disease and death.

Emergency health workers/organizations have the responsibility to try to cure the malnourished, prevent malnutrition amongst the vulnerable and promote adequate distribution of food to allow a healthy existence.

The complexity of food and nutrition as an issue means that the best response to a

situation depends on the context.

Part I attempts to define emergency nutrition needs (Chapter 1), to outline the information needs critical for decision making (Chapter 2), and some of the essential tools for assessing nutrition problems (Chapter 3). A range of potential interventions for alleviation of nutritional emergencies is then discussed (Chapters 4 and 5). The final Chapter deals with the necessity of evaluation as a means to manage programmes, monitor population needs and adapt programmes over time (Chapter 6).

Malnutrition, food insecurity and famine

Household <<food security>> is a concept that refers to the ability of a household to feed its members, enabling them to live full and active lives.

Inadequate household food security for a population, on short or long term basis may lead to different forms of chronic and or acute malnutrition.

While malnutrition is a disease of the individual, the causes of malnutrition are often complex and multi-sectoral, and are linked to different social and economic factors (see Figure 1).

Action to improve household food security (improve availability and access to food) may need to cover a broad range of sectors (agricultural, land ownership, price supports, inflation, taxation, etc.).

In emergency contexts, there is often a sudden and massive reduction in food availability (drought, conflict, isolation, siege, transport problems) or reduction in

food accessibility to some sections of the community (displacement, reduced purchasing power, increased prices). The result is often acute and severe food insecurity, which may lead to high levels of malnutrition and mortality.

In acute food crises the extent of global acute malnutrition means that nutrition becomes an emergency health issue.

However, even in emergencies, nutrition and food accessibility is a complex social issue and population groups may involve complex coping strategies to deal with reduced availability/access to food.

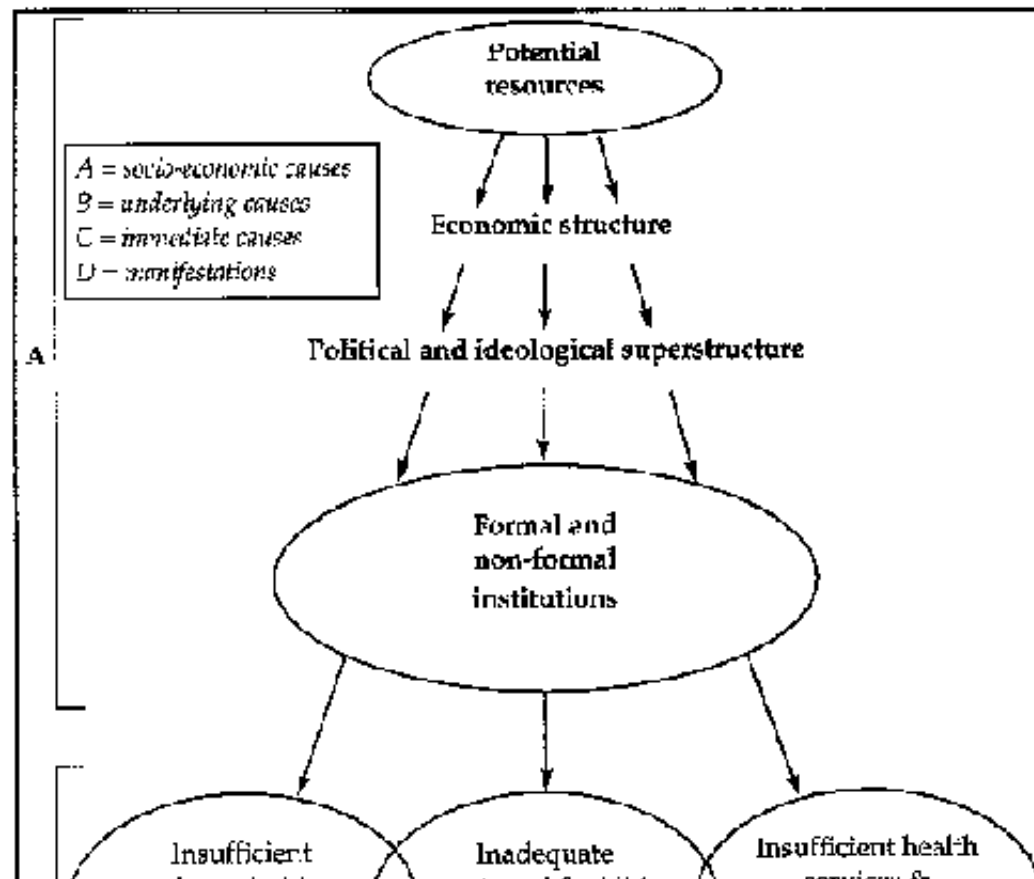

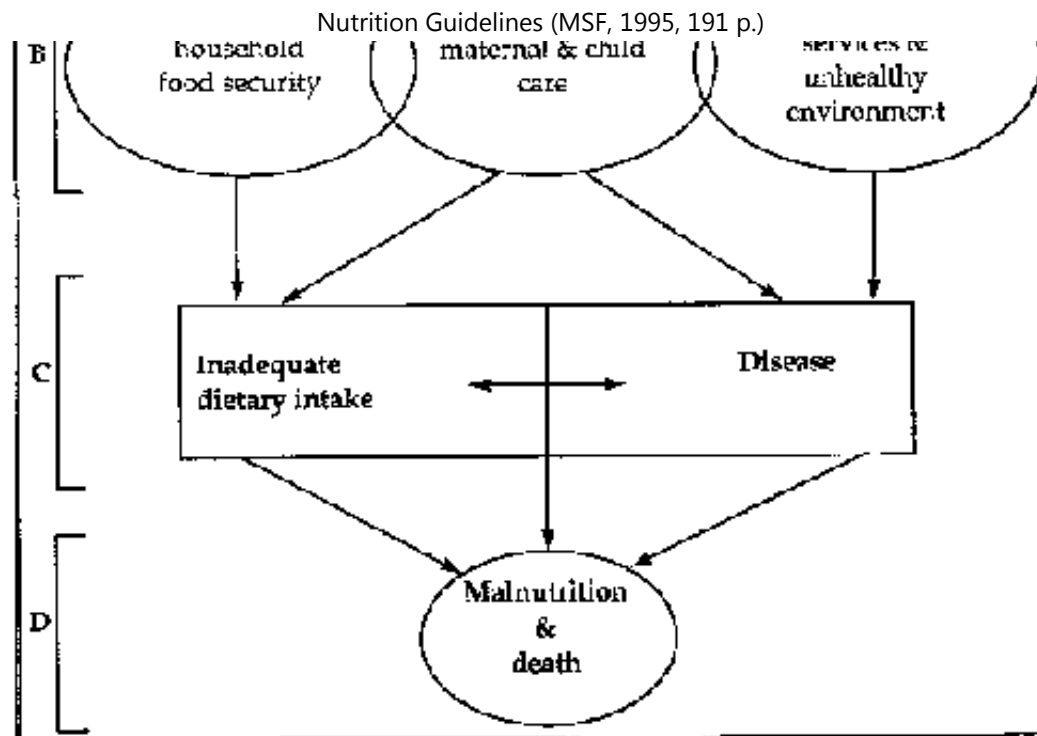

FIGURE

A complete breakdown in food security systems leads to acute food shortages which may lead to famine (a time of destitution and increased mortality).

The process of food shortage leading to famine has been described in different phases:

- 1. Change of behavior to cope with hard times (rationing of food, sale of excess cattle, etc.).**
- 2. Sale of capital and income earning assets - which means future prospects are damaged (loans, sale of essential tools, land or cattle).**

3. Break down of established life patterns and destitution (distress migrations, reliance on aid, etc.).

4. Starvation and death - famine.

Emergency food interventions

Under emergency conditions, General Food Distributions (GFD) aim to bring the nutritional value of the diet, for the whole population, up to a "sufficient" level for survival.

GFDs are often insufficient to meet the needs of all members of the population and/or distribution of food is unfair, so that certain vulnerable groups (growing children, pregnant and lactating women, elderly, handicapped) are at particular risk of becoming malnourished.

Different types of selective feeding programmes aim to cover special needs of certain vulnerable groups:

- Blanket supplementary feeding provides a quality or energy supplement in addition to the normal ration which is distributed to all members of identified vulnerable groups to reduce risk (preventive).**
- Targeted supplementary feeding provides energy or quality dietary supplements and basic health screening to those that are already moderately malnourished to prevent them from becoming severely malnourished and improve their nutritional status (curative).**

· Therapeutic feeding provides a carefully balanced and intensively managed dietary regimen with intensive medical attention, to rehabilitate the severely malnourished (curative) and reduce excess mortality.

Thus, the range of nutritional interventions vary from population based GFD to intensive, highly managed, curative, individual level interventions (intensive therapeutic feeding).

Health organizations working in food crisis situations have an obvious responsibility towards the curative rehabilitation of acutely malnourished individuals. However, the rehabilitation of malnourished individuals can become a pointless and frustrating task in a situation where the population simply cannot get sufficient quantities or quality of food.

Thus, emergency health workers also have a very great responsibility to promote the nutritional welfare of populations by advocating adequate GFD and other complementary interventions (see Figure 2).

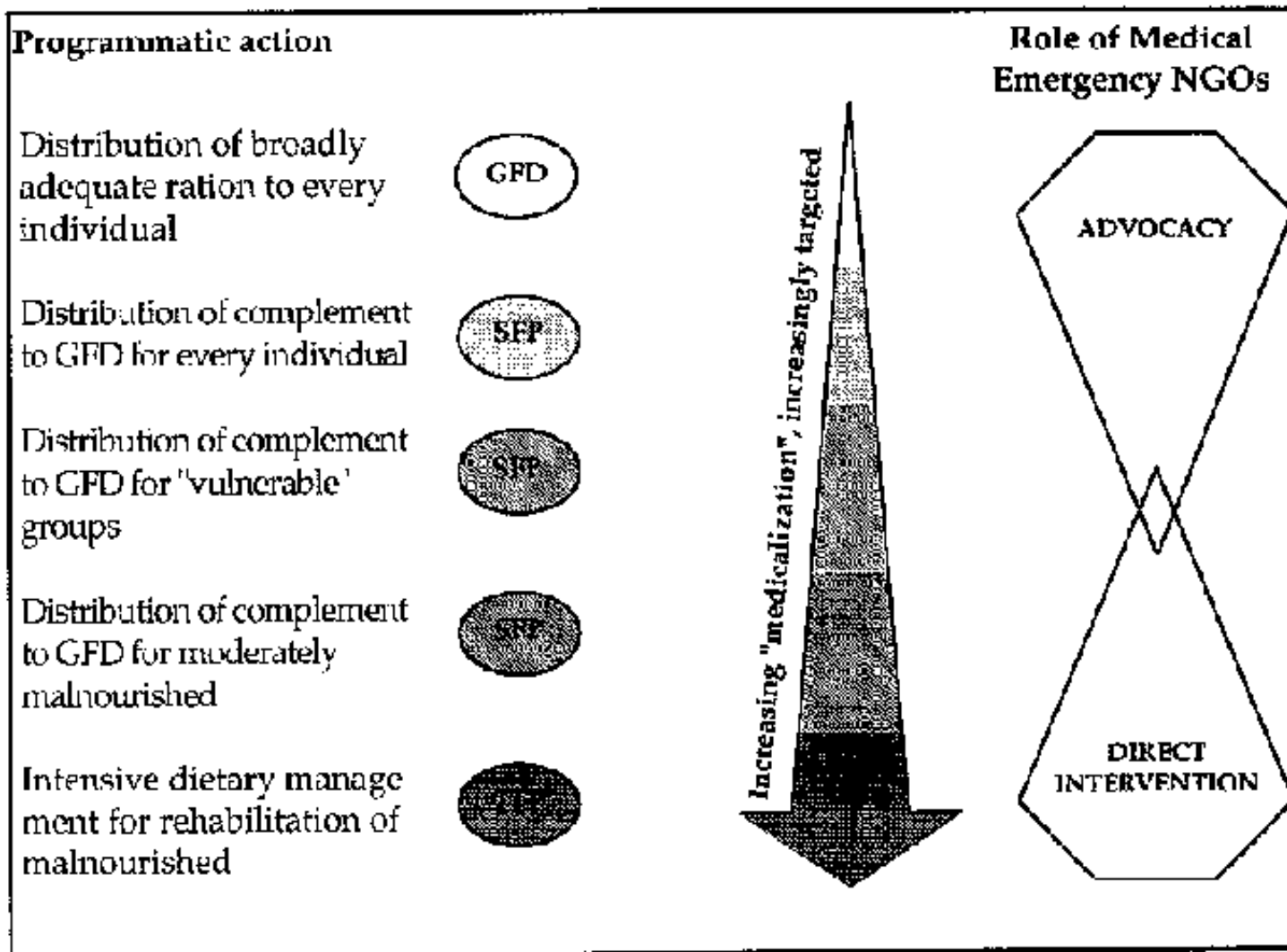

Figure 2 : *Nutritional Interventions in Emergencies and the Role of Medical Emergency NGOs*

FIGURE

2. Assessment of the nutritional situation

What do we need to know?

Information collected in order to take a decision, and to implement, alter, or stop programmes must be as clear and precise as possible.

· General information:

- Identify the origin of the problem (harvest failure, increased prices, population movements).**
- Identify the population that is effected (number, ethnic groups, displaced, villages, camps).**
- Identify other factors that may alter needs for intervention (other organizations, timing of harvests, national strategies).**
- Realise the logistic constraints.**

· Basic health information to be gathered must include (see Ref. 12, Annex 1):

- Mortality rates (crude and under five mortality rates);**
- Major infectious diseases (measles, diarrhoea);**
- Nutritional status of the people;**
- Water availability (number of litres/person/day);**
- Number of persons per latrine;**
- Shelter;**
- Amount of food available (Kcal/person/day).**

Where do we find the information? (see Ref. 10 and 13)

· Capital Level Visit

- **To collect all available information on relevant health, population and food/agriculture issues.**
- **To contact other organizations and find out their knowledge and plans to work in the affected area.**
- **To establish a realistic understanding with the authorities.**

- **Visits to the Field**
- **Talk to representatives of the population, or those with special knowledge (chiefs, health workers, agricultural extension agents, spiritual leaders, etc.).**
- **Talk to the affected people, in order to assess their ability to cope with the situation and their prioritization of needs.**
- **Observation (geographical area, water resources, shelter, adequacy of the food system).**

The initial evaluation is extremely important and needs to be global, brief, concise and fast in order to allow an appropriate intervention as quickly as possible (see Annex 1). However, if a high level of precision is required for decision making, it is necessary to use a structured survey methodology.

The feasibility and usefulness of the information will depend on if the situation is <<simple>> or <<complex>>. A <<simple>> situation (like a well established camp) is where the population is:

- **almost totally dependent on external food aid,**
- **population figures are well known,**

- the population is easily accessible.

A more "complex" situation (like an open area) has many different food sources and the population is very spread out and inaccessible.

Measuring Malnutrition

There are 3 major clinical forms of severe protein energy malnutrition - marasmus, kwashiorkor and marasmic kwashiorkor. There are various clinical signs useful for diagnosis, but most obviously a marasmic child is extremely emaciated and a child with kwashiorkor has bilateral oedema (see Ref. 1 and 3). However, clinical assessment is not practical for managing nutritional programmes and monitoring and comparing large scale food crises.

Most standardized indicators of malnutrition in children are based on measurements of the body to see if growth has been adequate (anthropometry; see Ref. 14, 15, 18, 20).

- Height for age (H/A), is an indicator of chronic malnutrition. A child exposed to inadequate nutrition for a long period of time will have a reduced growth - and therefore a lower height- compared to other children of the same age (stunting).**
- Weight for age (W/A), is a composite indicator of both long-term malnutrition (deficit in height/"stunting") and current malnutrition (deficit in weight/"wasting").**
- Weight for height (W/H), is an indicator of acute malnutrition that tells us if a child is too thin for a given height (wasting).**

For all 3 indicators (W/H, W/A, H/A), we compare individual measurements to international reference values for a healthy population (NCHS/WHO/CDC reference values).(Annex 13).

In emergencies, W/H is the best indicator as:

- it reflects the present situation;**
 - it is sensitive to rapid changes (problems and recovery);**
 - it is a good predictor of immediate mortality risk;**
 - it can be used to monitor the evolution of the nutritional status of the population.**
- Bilateral oedema is an indicator of Kwashiorkor. All children with oedema are regarded as being severely acutely malnourished, irrespective of their W/H.**

Therefore, it is essential to assess W/H and the presence of bilateral oedema to define acute malnutrition.

- Middle upper arm circumference (MUAC), is another anthropometric indicator. MUAC is simple, fast and is a good predictor of immediate risk of death, and can be used to measure acute malnutrition from 6 months to 59 months (although it overestimates rates in the 6-12 month age groups).**

However, the risk of measurement error is very high, therefore MUAC is only used for quick screening and rapid assessments of the nutritional situation of the population to determine the need for a proper W/H random survey (see Annex 2).

(For the assessment of adult and adolescent malnutrition, see Annex 3.)

Measuring the Nutritional Status of a Population

Anthropometric surveys allow us to quantify the severity of the nutritional situation at one point in time, which is essential to help plan and initiate an appropriate response.

The prevalence of malnutrition in the 6 - 59 month age group is used as an indicator for nutritional status of the entire population, because:

- this sub-group is more sensitive to nutritional stress,**
- interventions are usually targeted to this group.**

In order to ensure that the estimate will be representative of the whole population, random, systematic or cluster sampling procedures must be used (see Part II).

During the survey, the nutritional status of individual children is assessed, prevalence of malnutrition is then expressed as the percentage of children moderately and severely acutely malnourished. It is very important to mention:

- the indicator (W/H, OEDEMA, MUAC),**
- the method of statistical description (% of the Median, Z-Score),**
- the cut-off points used.**

Results should always be expressed as the percentage of children < -2 Z- Scores and < -3 Z Scores and/or oedema, to allow international comparisons as well as for statistical reasons.

However, it might also be necessary to express the results using a different classification system, if that is the method generally used in the area that you are working in.

The cut-off points most often used to define acute malnutrition for the different indicators during nutritional emergencies are:

NUTRITIONAL STATUS	W/H Z SCORE	W/H % of MEDIAN	MUAC
Moderate Acute Malnutrition	between -3 and < -2	between 70% and < 80%	between 110mm and < 125mm
Severe Acute Malnutrition	< -3 or oedema	< 70% or oedema	< 110mm or oedema
GLOBAL ACUTE MALNUTRITION	< -2 or oedema	< 80% or oedema	< 125mm or oedema

* Results expressed by different methods are not directly comparable.

FIGURE

WHEN TO CONDUCT A NUTRITION SURVEY

Ideally, an anthropometric survey should be part of the initial assessment in every emergency situation. The malnutrition rate can be used:

- to establish the degree of emergency for the delivery of food aid;
- to plan complementary interventions;
- as baseline information to monitor the progression of the situation over time.

Survey information might be useful under certain circumstances. For example:

- **Camp formation is usually sufficient evidence of problems with food supply, and an anthropometric survey is an essential part of the initial needs assessment.**
- **Health information systems or famine early warning systems indicate a deteriorating nutritional situation.**
- **Health organizations often have a good field presence and close contact with the population. When secondary information or field experience (from contact with health workers, local chiefs, extension workers, other NGO/government workers) indicates a major nutritional problem, an anthropometric survey should also be considered. Nevertheless, conducting a survey is expensive and consumes time and energy. You must consider the following aspects before actually starting a survey:**

1) Will results of the survey be crucial to decision making?

If the needs are obvious, a survey may not be needed to mobilize full scale action and will only waste time.

Secondly, one should be prepared to act after identifying a problem, directly or indirectly. If this is not possible and the information will not affect anyone's decision, do not do a survey.

2) Is a survey feasible?

Risks from insecurity, and logistic and team capacity should be considered.

3) Is an anthropometric survey the only option?

In stable environments, it may be better to establish a system of data collection that helps track trends in the nutritional status of a population over time. Only when there are dramatic changes (i.e. deterioration of the nutrition situation, influx of people, natural disaster, epidemics) might there be a need for further anthropometric surveys to determine the absolute levels of acute malnutrition.

4) Are you able to get access to all of your population of interest?

It is essential to make a clear definition of the population of interest (political/administrative boundaries, geographical regions, etc.), from which to draw a representative sample. If all sections of the population of interest are not reachable, * may not be worth doing a survey.

WHEN TO REPEAT A SURVEY

There are no hard and fast rules about the required frequency of anthropometric surveys.

In a simple situation:

In the emergency phase, surveys should be repeated quite often (i.e. every 3 months) as food supply systems are often weak, there may be considerable influxes of people, a greater risk of epidemics and elevated mortality rates.

Once the situation has stabilized and mortality rates have declined, the frequency of anthropometric surveys can be decreased.

In complex situations:

Organizing a survey in insecure regions or where the population is spread out is logistically more difficult and results are harder to interpret. A good anthropometric survey may provide critical information, but the frequency and regularity with which they are conducted should depend on priorities and the capacity of the team to implement the surveys.

A compromise may be to do an initial survey, then collect other data in order to monitor the situation (i.e. OPD data, hospital admissions, food availability and prices). Extreme caution is needed in interpreting this kind of non-representative data over time. If the groups measured are well known and the data shows consistent trends over time, then they may be a very useful source of information.

When trends indicate a rapidly worsening situation and there is a need for more precise estimation of the severity of the problem, then another survey should be conducted.

- An anthropometric survey should be part of the initial assessment of an emergency situation. Discuss beforehand how the results of the survey will influence decision making.**
- When feasible and useful, anthropometric surveys should be repeated regularly.**
- In more volatile situations, repetition of surveys may not be possible on a regular and frequent basis. An initial survey can be complemented with the collection of other data to monitor trends over time - a deterioration in the situation can prompt another survey.**

HOW TO INTERPRET THE SURVEY

There are crucial survey figures, that will be used for decision making and reporting:

- **global acute malnutrition rate**
- **severe acute malnutrition rate**

In addition to describing and quantifying the severity of the situation, one must also have information on:

- **Factors that might bias the estimate of severity.**
- **The distribution of malnutrition in the population.**
- **Context factors that will influence interpretation.**

Factors that might bias the estimation of rates of malnutrition

- **Excess mortality of the most vulnerable might result in an underestimation of the true malnutrition problem (see Annex 9: <<gaps>> in the sample's age/height groups may show an under-representation of an age group or a sex group which might indicate elevated mortality).**
- **Timing or seasonality might make comparison of results from different periods hard to interpret.**
- **When malnutrition is mainly a problem in age groups other than the under 5 years (rare), survey results might underestimate the problem.**
- **Migration or absence of the worst effected families will tend to reduce the significance of malnutrition rates.**

- **Inadequate population data or access to certain segments of the population may mean that certain groups are left out of the estimation of malnutrition rates.**

Distribution of Malnutrition within the population

The identification of population groups most affected can help target programmes more effectively. Sub-analyses of the anthropometric data may help suggest target groups:

- **Malnutrition rates per age/sex group (Annex 9).**
- **Malnutrition rates by population group (displaced/residents, ethnic groups, etc.).**
- **Malnutrition rates per geographic area.**

Contextual factors in the interpretation of anthropometric surveys

The interpretation of anthropometric surveys must take into account the context.

a) Interpretation in simple situations

Interpretation of anthropometric survey results should take into account 3 main aggravating factors:

- **Mortality figures (see Annex 1 for <<acceptable>> mortality figures);**
- **General food rations (Chapter 3);**
- **Major epidemic outbreaks (measles, Shigella and other diarrhoeal diseases,...).**

b) Interpretation in complex situations

In complex situations, both food availability and accessibility can be at the base of the nutritional problem.

Figure 3 outlines various factors that can influence food availability and/or accessibility and therefore may have an impact on nutritional status.

In complex situations, an anthropometric survey may not provide sufficient information with which to make informed decisions. In these conditions, other information (existing, information collected by rapid assessments or additional information collected during the anthropometric survey) will be needed to characterize the situation.

Figure 3 : Different Factors Effecting Individual Nutritional Status at Different Levels in a National Resource Field
(From Mason, Habicht, Tahara and Velazquez, WPN 1994)

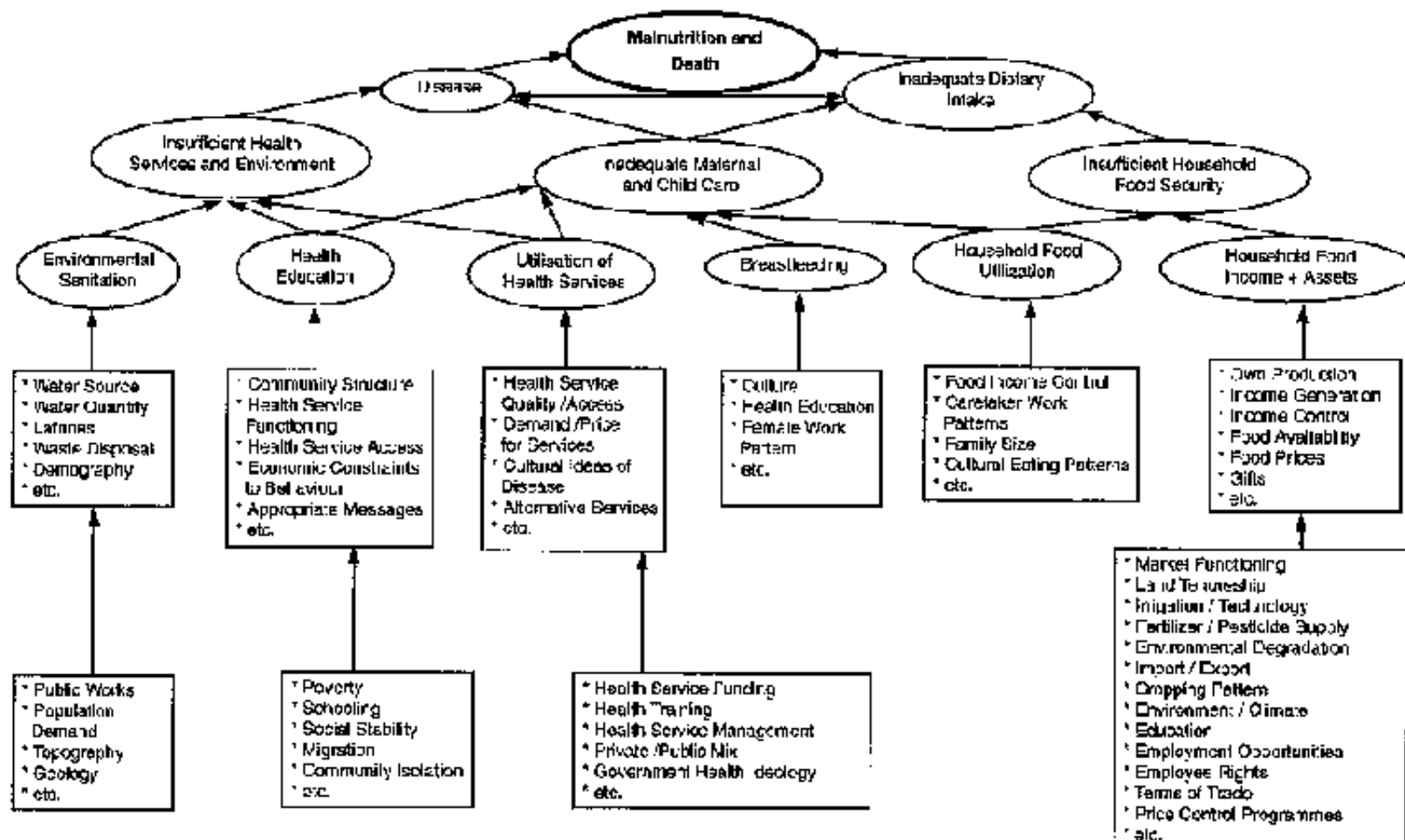

FIGURE

The survey data may therefore need to be complemented with the following additional information:

- * **Market prices of important cereals and livestock**
- * **Information on access and availability of food**

- * **Price and availability of seeds and tools**
- * **Rainfall, pests and other agricultural information**
- * **Major events with respect to mortality and morbidity**
- * **Specific nutritional deficiencies (e.g. scurvy, pellagra,...)**
- * **Food intoxication cases (rare)**
- * **Information from health centres or clinics.**

The interpretation of these data types will depend on an understanding of the normal circumstances, and what a change in the indicator actually means.

Often an important factor to consider is seasonality. The timing of harvests and hunger periods explains much of the yearly variation in the nutritional status of some populations. Some communities live constantly on the edge, due to poverty and seasonal food shortage.

HOW TO USE SURVEY RESULTS

· Context

In simple situations it is possible to use survey results to make straight forward decisions and implement standard programmes. In more complex situations it is important not to encourage camp formation through our nutritional interventions. In complex situations, it is essential to adapt standard strategies to support local coping strategies and reflect social and demographic patterns in the population.

· Survey timeliness

As stressed earlier, nutrition surveys are only useful if they inform decision

making. Surveys should be conducted so that the results are ready in time for important decisions that need to be made. Survey results should also be shared with other organizations, to help them make more informed decisions.

- **Causes**

The causes of the nutritional problem may greatly effect the choices to be made in designing a nutritional programme. You may have an idea of the causes, as this knowledge may have prompted the survey (i.e. inadequate food rations for an extended period of time, crop failure). However, it may be necessary to investigate causes by asking community leaders about the problems or by asking the mothers of the malnourished.

- **Logistics survey**

Survey results may imply a certain intervention strategy, but programmes must be designed to reflect the logistical realities and the team capacities.

When conducting a nutrition survey, the various teams will travel extensively through the area of interest, they will have opportunities to talk to representatives of many communities and observe some of the constraints faced by the population.

The survey team should take advantage of the field experience to collect information useful for interventions:

- **Teams can be asked to map out their paths to villages and report on broken bridges, impassable rivers, etc.**

- **Teams can report on the spread of the population in various areas.**
- **Teams can report on the availability of water and cooking fuel for the population.**
- **Surveys are expensive and time consuming so one should take full advantage of the opportunity to collect relevant information when conducting a survey.**
- **One should never ask too many questions.**
- **However, key information can help make the analysis of the nutritional situation and associated factors much stronger.**

SUCH INFORMATION MUST BE IDENTIFIED BEFORE THE SURVEY - it is impossible to go back and ask the questions later.

- **It is useful to consider more than just the traditional rates of malnutrition for decision making.**
- **Additional information collected and special sub-analyses of the data will allow speculation about causes and identification of most effected groups - thus enabling better design and targeting of the programme.**
- **The experience gained while conducting the survey can provide important additional information for practical considerations in programme planning.**

The feasibility, reliability and usefulness of an anthropometric survey depends on the resources of the organization and the level of complexity of the situation.

In "simple" situations where food systems are controlled, the population is well monitored, anthropometric surveys are relatively easy to plan, conduct and interpret - interpretation must take into account the adequacy of food rations, mortality and epidemics.

· In more "complex" situations, anthropometric surveys are difficult to perform adequately and results are often insufficient to characterize a situation and make decisions - other critical information must also be collected to help interpretation.

3. Interventions: ensuring adequate general food availability and accessibility

Meeting basic food needs for all

In certain emergency situations the self-reliance of the population is reduced to such an extent that they may become totally dependent on the international community for their livelihood.

The classical intervention to meet basic food needs of refugees, the displaced and destitute is a General Food Distribution (GFD). Emergency health organizations prefer to concentrate on their areas of expertise and leave GFD to organizations with more specific experience. Nevertheless, the emergency health organizations have a tremendous responsibility to monitor the quality, quantity and equity of distribution.

In international refugee camps, UNHCR and WFP will agree on their responsibilities to ensure the food supply to the affected population. WFP will supply the basic commodities of the general food ration and the funds for transport and handling of these commodities. UNHCR should provide refugees

with complementary food items where necessary: fresh vegetables, fish or meat, spices. UNHCR also coordinates the transport and distribution of the food, which may be sub-contracted to other agencies. UNHCR will also often take responsibility for the supply of food items to supplementary feeding programs (see Annex 4).

QUANTITY OF GENERAL FOOD RATIONS

It is impossible to tailor the food basket to individual needs - so an average general ration has been proposed, designed to meet minimum nutritional needs.

Different guidelines exist between different agencies defining what level of ration is "adequate":

WFP: minimum of 1900 Kcal/person/day.

ICRC: 2,400 Kcal/person/day.

MSF: 2,100 Kcal/person/day.

Although WFP and UNHCR are currently working on new guidelines for a more accurate assessment of population food needs and will not work with a set target ration in the future.

The overall ration (average N^o Kcals) received is not the only factor of importance

- food must be provided regularly to ensure a constant flow of food to families to avoid hunger and must be of sufficient quality (protein, fats, minerals and

vitamins) to promote a healthy existence.

Most health organizations believe that the 1900 Kcal/person/day ration is insufficient (when there are no other sources of food).

Generally speaking, the minimum ration should aim to provide 2100 Kcal/person/day (of which, at least 10% of energy should be from protein and 10% from fat. See Annex 6 and 7). The provision of an adequate food ration has been clearly shown to have a critically important effect on the recovery and maintenance of a satisfactory health status in camp populations (Ref. 4 and 2)

The classic full food basket contains 6 basic commodities; a cereal, a pulse, oil/fat, possibly a fortified cereal blend, sugar and salt and occasionally may include some canned fish or meat.

Example of a recommended ration

Commodity	Recommended ration (g/person/day)
Cereal : maize	400
Pulse : beans	60
Oil/Fat : vegetable oil	25
Fortified Cereal Blend : corn soya blend	100
Sugar	15
Salt	5
Kcals	2261 Kcals
Protein (* = g, ** = % Kcals)	* 71.2g, **12.6%
Fat (* = g, ** = % Kcals)	* 47.9g, **19.1%

(See Annexes 5 & 6 for guidelines on the calculation of the caloric content of alternative food baskets).

FIGURE

(See Annexes 5 & 6 for guidelines on the calculation of the caloric content of alternative food baskets).

Factors that require an increase in the general ration:

- Age and sex composition of the population: an excess of male adults or pregnant women calls for higher rations per capita.**
- Bad general health and nutrition status: widespread illness, epidemics, general undernutrition or a crude mortality rate >1/10,000/day, implies the need for an**

increased ration.

- **Activity level: during periods of increased activity (intense agricultural labour, specific infrastructure works or other labour intensive activities - pounding/milling cereals supplied, fetching water and firewood from great distances), the energy component of the ration should be increased.**
- **Low temperatures: a drop in temperature will increase metabolic energy expenditure and thus dietary needs. The cold or wet season (cold nights), lack of shelter, blankets and clothing should be taken into account when calculating ration levels. An additional 100 Kcal/person/day should be added to the ration for every 5°C that the environment temperature drops below an average of 20°C.**

Factors that might alter the need for food aid:

- **Activities that provide a direct (i.e. farming, foraging) or indirect (income generating) supply of food to the household. When income generation and other coping strategies are inhibited for large segments of the population, the general ration should cover all of the nutritional requirements. If the population is still able to participate in some (but insufficient) economic and food producing activities, general rations may only need to cover some of the nutritional needs.**
- **Those severely affected by emergencies have many needs other than their dietary requirements. If other requirements (i.e. shelter, fuel or firewood, water, transport costs, health services and social functions) are not met by other agencies or individual income, part of the general ration will be bartered or sold in exchange for these commodities or services.**

- **Acceptability and familiarity of the food items: it is a misconception that people will eat anything if <<really>> hungry. Some taboos, impala/ability or lack of knowledge/tools for food preparation might reduce the real intake of the food supplied - implying the need for other commodities to be distributed.**
- **The diet provided is very monotonous and may be culturally unacceptable. If there are preferred food items available through market systems, part of the general ration will be bartered or sold in order to buy preferred goods (tea, herbs, local staples, vegetables). Bartering distributed food items on the market is often an essential survival technique and should not be regarded as an indicator that the population gets too much food and no longer requires the same levels of GFD.**
- **Processing, storage of food and other wastage in the chain, from household receipt of food to consumption: through specific milling, storage and cooking procedures, food can lose part of its nutritional value; the micronutrients are especially vulnerable to destruction or deactivation.**

Distribution system losses

- **Losses in the transportation, storage, processing and distribution of food from the donor to the individual can often account for a large proportion of the food aid.**
- **Losses, due to bad management or corruption, can hide food needs, as overall food input to a country/region may seem adequate to meet calculated theoretical food needs, without reaching many of the needy. Thus, the calculated theoretical ration is often different from that actually received by individuals.**

QUALITY OF THE GENERAL FOOD RATION

Ration composition is often calculated with insufficient attention paid to the nutrient content. Consequently, refugees and displaced often suffer from micronutrient deficiencies.

Complementary food items, supplied with the basic ration, may not contribute significantly to overall energy intake, but are often crucial for increasing the acceptability, palatability and quality of the food ration (i.e. protein, micronutrients). Unfortunately, food basket commodities and ration levels are often determined by what surpluses donor governments wish to dispose of. Due to the donor driven supply of food aid and the logistical difficulties with food distributions, food baskets seldom contain 6 items and are rarely upto standards in terms of energy content, micronutrient content or acceptability.

The risk of specific nutrient deficiencies can be estimated from the composition of the general food ration. The following table gives you some clues as to which deficiencies might be expected according to the composition of the food ration.

COMMODITY	RISK	POSSIBLE SOLUTIONS
Maize	Pellagra (Vitamin B3 (Niacin) or a low protein diet with no tryptophan)	<ul style="list-style-type: none"> - Nuts, beans, wholegrain cereals - Meat, fish, eggs, milk - Fortification
Polished rice	Beri-beri (Vitamin B1 (Thiamine) deficiency)	<ul style="list-style-type: none"> - Parboiled rice/whole grains - Groundnut, legumes - Meat, fish, milk, eggs - Fortification
No fresh fruits or vegetables	<p>Scurvy (Vitamin C deficiency)</p> <p>Night blindness and xerophthalmia (Vitamin A deficiency)</p> <p>Anaemia (Iron deficiency)</p>	<ul style="list-style-type: none"> - Onions, cabbage, peppers - Canned tomato paste - Vitamin C tablets - Green leaves and bright coloured vegetables/fruits - Butter or red palm oil - Vitamin A capsules - Greens - Meat/fish - Iron/folic acid supplementation - Fortification

(A description of the major clinical symptoms of micronutrient deficiencies is given in Annex 7).

FIGURE

(A description of the major clinical symptoms of micronutrient deficiencies is given in Annex 7).

The role of health organizations

In the absence of an adequate general ration, selective feeding programs and other dietary supplementation will have limited or zero impact.

The relevance and effectiveness of specific feeding programmes should always be evaluated as complementary to an adequate general food ration.

It is the duty and responsibility of emergency health organizations to monitor the regularity and adequacy of the general food ration supplied to the beneficiaries. As emergency health organizations are often the only operatives with a full time field presence, they may be the only witnesses available. The general health and nutrition status of the population in need and the impact of selective feeding programmes depend on it.

Monitoring implies an active collection of relevant data, and targeted reporting of information to the authorities and agencies concerned to influence distribution activities as needed (see Annex 8).

Advocacy can be cooperative or adversarial, it is always better to try and cooperate with food distributing bodies. However, sometimes the political aspects or corruption involved in food distribution become overwhelming and distributors are unwilling to try to alter practices. In these instances, advocacy becomes adversarial and media and political channels must be used to expose distributors and hold them accountable.

FOOD SYSTEM MONITORING

It is crucial to have information on the actual amount and quality of food that reaches the family or beneficiary. There can be substantial differences between what is actually received per capita and the theoretical general food ration (GFR). Furthermore, there may be considerable variation in the levels of access to food rations by individuals between/within populations.

It is useful to discern several levels within the food distribution system (see Figure 4).

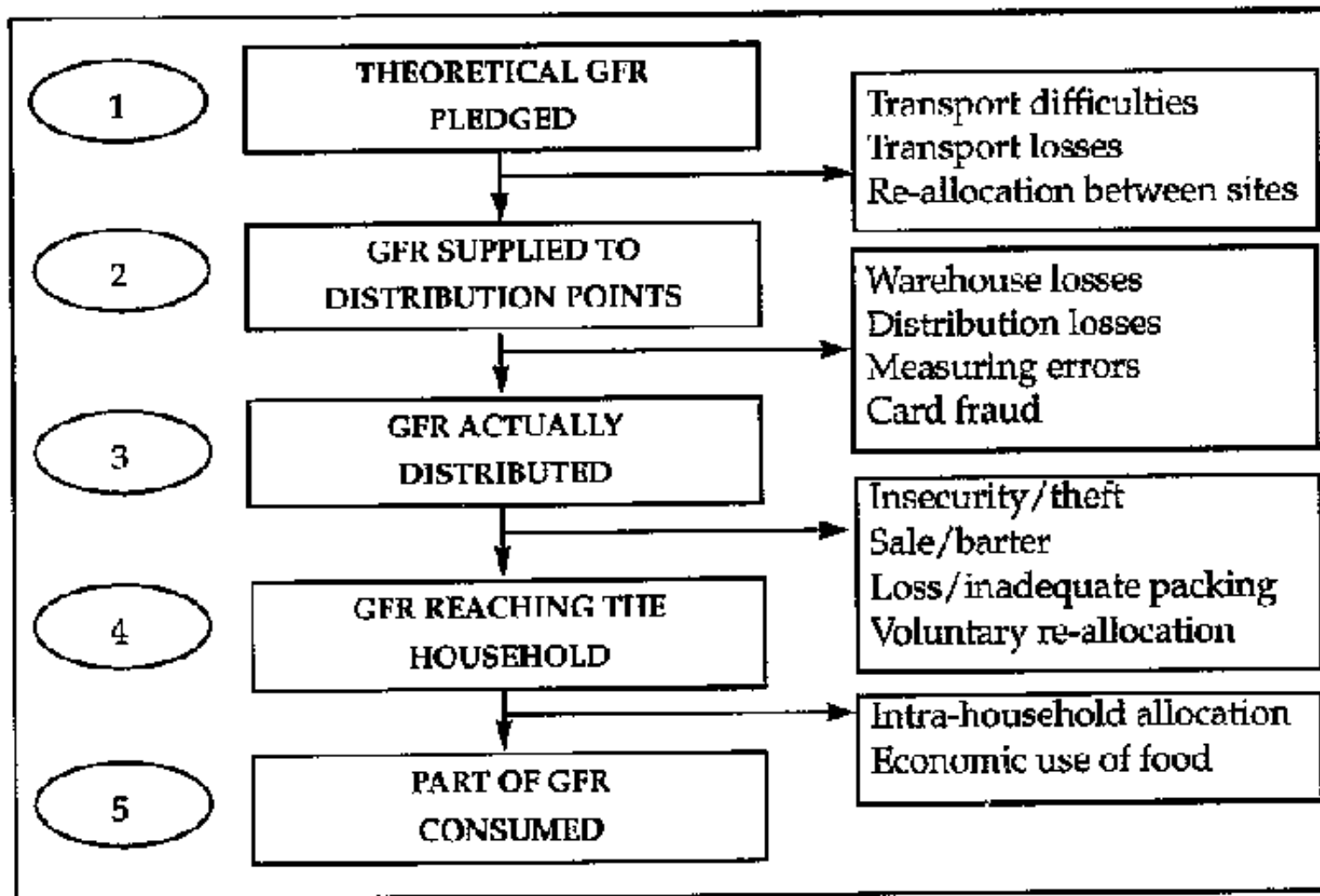

Figure 4 : Food flow from the donor to the beneficiary

FIGURE

Between steps 1 and 3 there may be several organizations involved, with different constraints and capacities. It is necessary to understand the chain of responsibilities and locate where responsibilities are not being met. Information

from various sources should be collected and investigated, to get as close as possible to the real situation:

- Theoretical GFR:

- **Relief coordinating agency (UNHCR, government department, etc.)**
- **Donor agency (WFP, EEC, USAID, etc.)**

- Generalfood ration reaching the distribution spot:

Implementing agency (Red Cross/Crescent, Care, relief committee, etc.). There may be several implementing agencies for different steps in the chain or covering different geographic areas - it is necessary to delineate their individual responsibilities and follow their individual actions to establish where changes need to be made.

Information can be collected from stock management reports, distribution reports, presentations at coordination meetings or personal contacts.

- Generalfood distribution actually distributed:

- **Implementing agency**
- **Beneficiary or community representatives**
- **Independent observers**

Information can be collected and compiled from distribution reports, feed-back

from beneficiaries and observation near distribution points. At the distribution point, a more formal investigation is possible (i.e. food basket monitoring - the regular weighing of allocated rations to randomly selected beneficiaries just after distribution).

Food basket monitoring implies the regular investigation of the quantity and quality of food items which are received at the household level. UNHCR is now actively seeking partners in the field, to monitor distributions it is responsible for, in order to increase accountability to donors and improve management of food distribution systems and refugee crisis situations (see Annex 8).

- Food ration reaching the home:

- Beneficiary and community representatives**
- Independent observers**

Information can be collected and compiled from talks with families and household food availability surveys (i.e. formal weighing of available items in chosen shelters, to calculate the food availability per person till the next planned distribution).

- Food actually consumed:

- Household food consumption surveys (difficult and time consuming - consult headquarters before considering this option).**

Alternatives to general food distribution

In certain rare situations, the mass preparation of cooked meals is the only way to ensure access to food for the population, due to insecurity (Somalia 1992) or lack of ability to prepare foods (i.e. lack of firewood in Ethiopia in 1985). It is important not to under-estimate the logistical requirements of preparing food for large numbers of people. More importantly, these programmes should only be a temporary last resort, as the negative psychosocial consequences of mass feeding compound the distress of the affected population.

In some cases in which financial access to basic food items is the main problem, subsidy of food items or even cash distribution can alleviate the problems. These kinds of interventions require a thorough analysis of the situation and the legal/ administrative implications require specialised advice.

In camp situations or areas of high population concentration (displaced settlement zones), there may be programmes to promote income generation and to grow certain nutrient rich foodstuffs (i.e. vegetables). Well implemented vegetable gardens have proven to be a valuable contribution to dietary balance and a means for income generation.

For a population group dependent on external aid, a general food ration should:

- provide an average minimum ration of 2,100 Kcal/person/day; 10% of the energy should be in the form of protein and 10% in the form of fat; provide a balanced and sufficient intake of essential vitamins and minerals;**
- contain items that are acceptable/familiar to the beneficiaries;**
- be adapted to the particular circumstances that alter individual nutrition and food requirements. Emergency health organizations do not usually participate in GFD,**

but they should assume responsibility for:

- **food basket monitoring (overall quantities, quality, regularity and equality of access);**
- **attentiveness towards other, varied information on the circumstances and the impact of GFD;**
- **advocacy to specific targeted decision makers;**
- **coordination with other agencies responsible for supply and logistics of food aid.**

4. Interventions: selective feeding programmes

Even if the overall food needs of a population are adequately met there may be inequities in the distribution system, disease and other social factors causing degrees of malnutrition in certain vulnerable groups

Vulnerable groups may be targeted to receive a food supplement in order to upgrade their diet to a level that responds to their increased needs.

Those that are already acutely malnourished must receive medical and nutritional attention in order to rehabilitate them to a healthy state.

The following decision tree can be used to help interpret the seriousness of the situation but should not be interpreted as a set of rules.

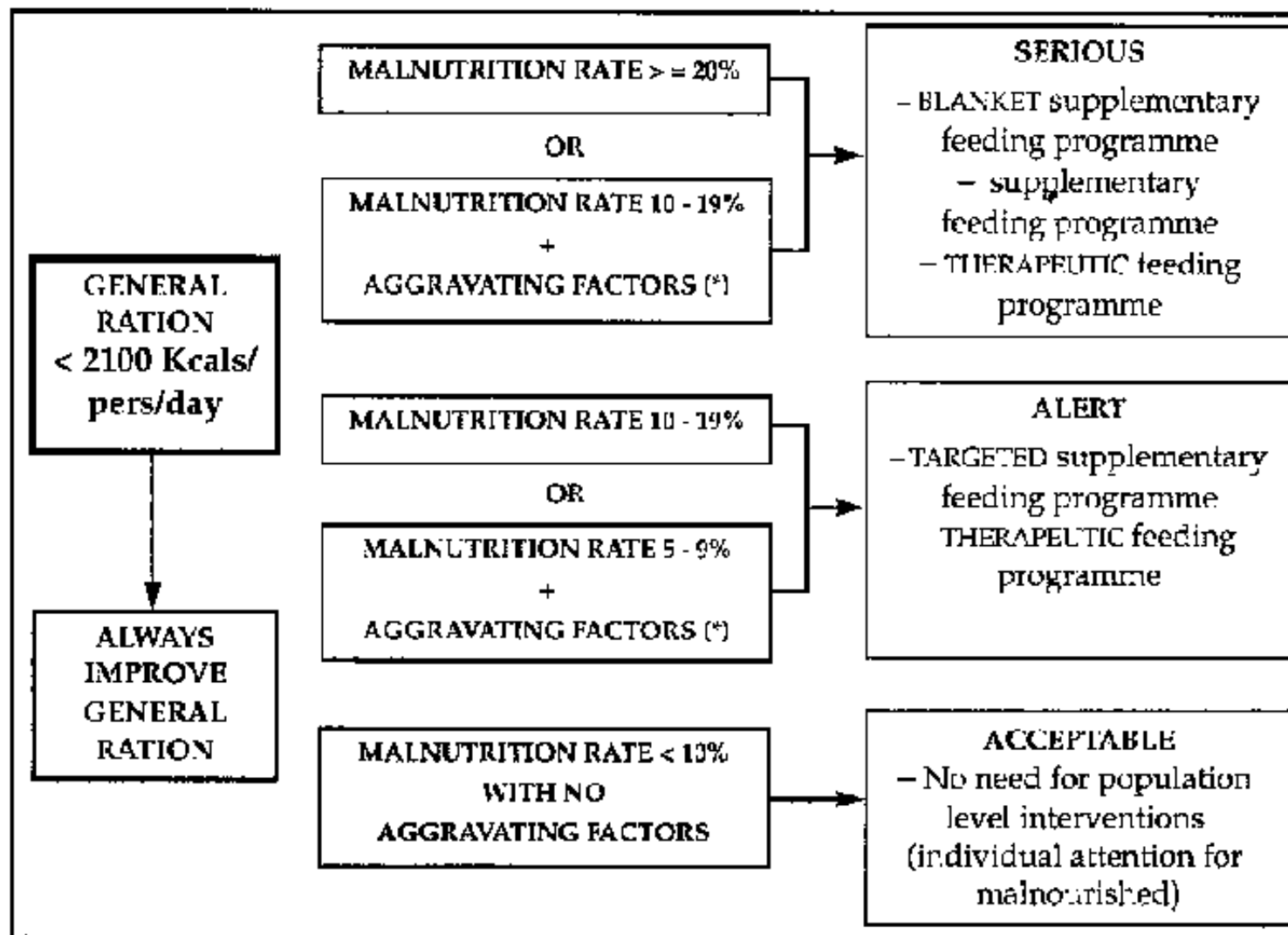

Figure 5 : General guidelines to assist in decisions to implement nutrition programmes

FIGURE

Figure 5: General guidelines to assist in decisions to implement nutrition programmes

(*) Aggravating factors to consider are:

- **Mortality: Crude Mortality Rate (CMR) > 1 / 10.000/day;**
- **Inadequate general food ration**
- **Epidemic of measles, shigella or other important communicable diseases**
- **Severe cold and inadequate shelter**

Objectives of selective feeding programmes

The general objective of a therapeutic feeding programme (TFP) is to reduce mortality by taking care of those vulnerable groups at greatest risk of dying from causes related to malnutrition. Generally the target group is children less than 5 years with severe acute malnutrition.

The general objective of a targeted supplementary feeding programme (SFP) is to prevent the moderately malnourished becoming severely malnourished and thereby reduce the prevalence of severe acute malnutrition and associated mortality.

In a situation of a grossly inadequate general food supply, it may be necessary to organise a Blanket Supplementary Feeding Programme for all members of the vulnerable groups (for a short period of time). The objectives of this programme are to prevent widespread malnutrition and mortality. In this case the programme may include up to 40% of the total population ! In such a situation, however, first priority should be given to restoring the general food supply.

PROGRAMME	OBJECTIVES	TARGET GROUP
TFP	<ul style="list-style-type: none"> • Reduction of under 5 mortality rates 	<ul style="list-style-type: none"> • < 70% or < -3 Z-Scores W/H (severely malnourished children under 5 years) +/or • oedema
Targeted SFP	<ul style="list-style-type: none"> • Reduction of % of severe acute malnutrition in under 5s • Reduction of under 5 mortality rates 	<ul style="list-style-type: none"> • 70% - < 80% or -3 to - < - 2 Z-Scores W/H (moderately malnourished children under 5 years) • Malnourished individuals above 5 years • Children discharged from a TFP
Blanket SFP	<ul style="list-style-type: none"> • Prevention of further deterioration in the nutritional situation • Reduction of under 5 mortality rates 	<ul style="list-style-type: none"> • Children under 5 years in general • Pregnant and lactating women • Socially and/or medically needy individual cases • Elderly persons

FIGURE

Other factors like general food supply, water and sanitation and general health services also have a major impact on the pattern of mortality, disease and malnutrition.

Objectives of feeding programmes should be specified to be realistic and feasible,

and must therefore take into account the local conditions and project capacity.

Example 1:

In a displaced population, a nutrition survey among 6 - 59 month old children indicates 15% acute malnutrition (Confidence Interval 15 + 3%) (<-2 Z-Scores W/H and/or oedema) and 3-5% acute severe malnutrition (<-3 Z-Scores W/H and/or oedema). Mortality surveillance shows a crude mortality rate of 2/10,000/day and an under-five mortality rate of 4/10,000/day.

It is necessary to implement a TFP, targeting the severely acutely malnourished and a targeted SFP for the moderately acutely malnourished.

The target population (50,000) is settled in two camps, with well established health services in each camp, which are easily accessible for the entire population.

Therefore, it seems realistic to set the objectives of the TFP and SFP to: - a coverage of 90% of severely malnourished children,

- a coverage of 80% of moderately malnourished children,**
- a recovery of 80% of children admitted to the TFP and 70% to SFP,**
- a reduction of the mortality among severely malnourished children admitted to the TFP to below 5% and the reduction of the under 5 mortality rate to < 2/10,000/day,**
- a reduction in the prevalence of severe acute malnutrition to < 2% (<-3 Z-Scores W/H +/or oedema).**

All objectives should be reached within 3 months.

Example 2:

In another, newly displaced population, a nutrition survey also indicates 15% global acute malnutrition and 3% severe acute malnutrition in under-fives. As the accessibility of the feeding programme will be limited, because the people live in scattered small settlements and often at large distances (> 2 hours walking) from the health services, the programme objective of a reduction of the severe malnutrition rate to below 2% has been set for within 6 months, and coverage objectives are re-set.

Example 3:

Because of a crop failure last year, there is a severe food shortage in a rural population, while the next harvest (which is expected to be normal) is still 3 months away. The global acute malnutrition rate among under-fives, which at this moment is 9%, will increase rapidly if nothing is done.

A blanket supplementary feeding programme will be implemented for all children under 5 years, for a period of 4 months (until after the next harvest) with the objective of stopping any further deterioration in nutritional status until the harvest.

5. Evaluation

The collection of information for monitoring and evaluation should be an integral part of all nutrition programmes. Evaluation is a learning process involving continuous collection of information to monitor the progress in achieving set goals and to suggest adaptations to the programme, or closure with time.

Monitoring and evaluation will involve the planned and regular collection and analysis of:

- PROCESS INDICATORS to evaluate the progress in implementation and the trends in programme needs over time (i.e. attendance rates, coverage, recovery rates).**
- IMPACT INDICATORS to evaluate the effect the programme is having/had on the population, and to summarize the total efficacy of the programme (malnutrition prevalence, mortality figures, numbers served).**

Assessment of impact is extremely difficult as analysis of trends in health indicators does not prove that the programme has caused the change. However, a well collected data set can be used to argue for an association of the programme with the change in overall health status.

It makes little sense to only look at indicators of IMPACT for evaluating a nutritional programme. First it is necessary to know that the programme serves a useful purpose and is running well. PROCESS information will allow you to see how well the programme is functioning and adapt programme emphasis and design over time. PROCESS Indicators should be thoroughly analyzed and Interpreted (see Chapter 8, Part III).

The collection of information for evaluation needs to be planned during initial programme design. If information is not collected in a regular and systematic fashion, quality and relevance of the programme cannot be assessed while giving services.

It is the responsibility of coordinators and the team to implement the collection of process evaluation data systems and compile and analyze the data. Coordinators and their teams should be prepared to act to change programme design and management procedures based on feedback received through regular evaluation (see Chapter 8, Part III).



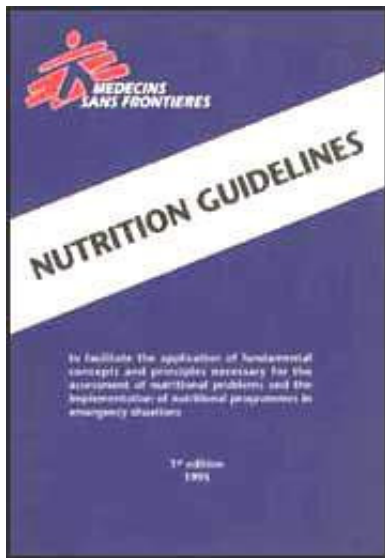

In camps, IMPACT indicators may be collected along with malnutrition prevalence rates, mortality rates, etc., and interpreted as a function of nutritional programme efficacy in conjunction with other relief activities.

[Home](#) > [ar](#).[cn](#).[de](#).[en](#).[es](#).[fr](#).[id](#).[it](#).[ph](#).[po](#).[ru](#).[sw](#)



Nutrition Guidelines (MSF, 1995, 191 p.)

Part II: Rapid Nutrition Surveys

-  1. Introduction to anthropometric surveys
-  2. Anthropometric measurements and indices
-  3. Sampling methods
-  4. Analysis, interpretation and recommendations
-  5. Conclusions

Nutrition Guidelines (MSF, 1995, 191 p.)

Part II: Rapid Nutrition Surveys

1. Introduction to anthropometric surveys

Introduction

When dealing with populations in emergency situations (refugees or displaced people), planners, health officers and officers in charge need to evaluate the nutrition situation quickly and precisely. This evaluation is based on surveillance data, demographic indicators, direct observation, advice from experts and in some cases rapid anthropometric surveys. The quick anthropometric assessment survey (measuring the prevalence of malnutrition) is one of the many tools for evaluation of the nutrition situation, allowing the quantification of malnutrition in the population.

ANTHROPOMETRIC SURVEYS: WHY AND WHEN?

- In the initial phase of an emergency, to assess the situation and take short term relief action.**
- In the course of a programme, to assess the evolution of nutritional status, to redirect nutritional programmes and to assess their coverage and impact. The survey may also help in assessing the impact of the programme: was the prevalence of malnutrition reduced? Was the target population covered?**
- In the course of a programme, when deterioration or amelioration of nutritional status is suggested by various sources of information: clinics, food availability.**

However, an anthropometric survey is not always a priority in emergency situations. A rapid screening of children presenting a high risk of mortality may be needed urgently in order to take immediate life saving action. An anthropometric survey only becomes a priority when there is an urgent need for intervention in order to take decisions to implement actions.

OBJECTIVES FOR SURVEYS

The objectives should include notions of time, place and persons.

The objectives of anthropometric surveys may be:

- to quantify malnutrition in a specified population, at a given time, using indicators of malnutrition;**
- to identify higher risk groups. These may be a certain age group, newly arrived refugees, nomads as compared to sedentary people, etc...;**
- to estimate the number of children who may benefit from a nutrition programme, e.g. how many children should be expected to need treatment in an intensive feeding care unit with an entry criteria based on a given nutrition index value? How many children could be eligible for supplementary rations?**
- to assess trends in nutrition status based on repeated surveys;**
- to evaluate a programme in comparison with a target objective;**
- to compare the nutrition status of refugees and the local population.**

Preparing to do a survey

MEET THE PEOPLE IN CHARGE

Most of the time a survey is carried out in response to the needs for information expressed by the people in charge. The objectives have to be precisely specified with them at this point. They need to understand the methodology used, its constraints, the means required and the limitations of the expected results. People in charge may provide a map of the camp or of the region, and a list or a register of the refugees if available.

GATHER AVAILABLE INFORMATION

Before starting the anthropometric survey, all locally available information should be gathered. Have there been any previous surveys? What were the findings and recommendations? Is there a reliable mortality surveillance system? What information related to food resources is available?...

Collecting demographic information prior to the survey is essential when this information is not readily available or reliable.

DEFINE DATA TO BE COLLECTED, THE PLAN OF ANALYSIS AND THE QUESTIONNAIRE

Data to be collected

During an anthropometric survey, the following basic data needs to be collected:

- **weight**
- **height**
- **age**
- **sex**
- **oedema**

and possibly, according to the specific objectives of the survey:

- **measles immunization status**
- **date of arrival in the camp**
- **availability of cooking equipment/fuel at the household level.**
- **availability of food**
- **etc.**

The additional questions that could be included should be limited in number. Data collectors and families should not be overwhelmed by the number of questions asked. Only variables with direct relation to nutritional status should be considered. A variable must be easy to measure, and its value should be precisely coded: has this child been correctly immunized against measles (Yes or No)? What is the month of arrival of this child in the camp? Only factors for which action can be taken should be included, such as the number of cooking pots per household.

Variables which are not precisely definable or easy to measure should not be included. For example, the presence of anaemia, because clinical assessment is not reliable and will vary from one data collector to another. Vitamin A or C deficiency assessment can only be included if all data collectors have been well trained in detection

Plan of analysis

Once the objectives have been clearly defined, a plan of analysis should be drawn up. The method of expression should be pre-determined for each indicator. The format for presentation of results can be pre-defined, and tables of results should be constructed without filling in the values. Doing this guarantees that appropriate measurements will be taken, appropriate questions asked and hence, that the objectives of the survey will be met.

The plan of analysis is composed of two parts:

- **Descriptive analysis**

In this first part, distributions according to the different variable data are constructed: how many boys and girls are there in the sample? Are all age groups represented? What is the proportion of oedema in the sample? This allows verification of sample representativeness and orientation of the analysis (see Annex 9).

- **Interpretive analysis**

Selected variable data is cross tabulated, in order to compare different groups of the sample according to certain characteristics: are younger children more malnourished than older children? Are the newly arrived refugees more malnourished than those currently in the camp?...

The number of cross tabulations should be kept to a minimum, concentrating on relevant information in order to take action for particular sub-groups of the

population. (For an example of a plan of analysis, see Annex 9.)

Questionnaire and information collecting form:

The plan of analysis helps to realize what information must be collected. The questionnaire must be designed to clearly collect all the necessary information (see Annex 12). The questionnaire is used in conjunction with a "surveyor manual" which summarizes the questions as they should be asked and answers most of the questions that a data collector will come across during the course of the survey. Age criteria (6 - 59 month), as well as definitions used in coding the variable data should be included in the surveyor manual (e.g. a correct vaccination against measles is a vaccination reported by card and administered after 9 month of age).

THE SCHEDULE

The date of the survey will be chosen with the help of community leaders and administrators. Special dates, such as a local celebration or a food distribution day, should be avoided because most of the people will not be found at home on such a day. The schedule of the survey should allow time for preparation, training, community mobilization, collection of data, analysis and writing of the report.

MEET THE COMMUNITY LEADERS

The community should fully understand the objectives of the survey and be included in the planning of the survey - community members should also be encouraged to participate during data collection. Important points, such as why children should be visited in their households and not in the clinics or feeding

centres, should be stressed.

EQUIPMENT

A list of the required equipment should be drawn up, including transport, fuel, measuring equipment, paper and pens, per diem, etc... (Annex 22).

SELECTION AND TRAINING OF THE DATA COLLECTORS. PRE-SURVEY

Data collectors currently involved in delivering health services to the population can be selected if their participation in the survey does not disturb health care delivery to the population. Data collectors do not need to be health professionals, anyone from the community can be selected and trained as long as they are able to read and write. In some cultures, women might be needed in order to deal with young children.

A survey team is composed of 3 people: 2 measurers and a supervisor. Two to four teams may be needed according to the size of the area to be covered.

The training of the data collectors is the corner stone in the course of an anthropometric survey. Each and every data collector should undergo the same training whatever his former experience.

The training takes 2 to 3 days, according to the number of people to be trained and the availability of trainers.

- The objectives of the surveys are explained.

- The sampling method and its rationale are detailed, stressing the importance of a representative sample.

- Height and weight measures are demonstrated. At least 20 height and weight measures should be performed by each enumerator. A test of standardization of anthropometric measurement is used in order to assess the performance of each data collector (the procedure for the test can be found in Annex 11). This test evaluates the precision and exactitude of the data collectors and allows misunderstanding of measurement techniques to be detected prior to the survey.

An on-site visit should be a part of the training, to see that all team members understand the sampling procedure, select the right children and correctly measure and question the respondents. The questionnaire should also be assessed for ease of use and suitability. This may mean having to do additional training or alter the questionnaire after the trial. Data collected during this pre-survey should not be included in the actual survey results.

- Define the survey objectives.**
- Collect available information.**
- Meet the people in charge.**
- Define a plan of analysis.**
- Draw up the questionnaire.**
- Inform the community.**
- Draw up a schedule.**
- Gather the necessary equipment.**
- Select and train the data collectors.**

2. Anthropometric measurements and indices

Anthropometry is the measurement of the human body. Body parameters such as weight and height are used to assess nutritional status.

The various anthropometric indicators and the method of measurement

Many body parameters can be used to assess individual nutritional status. The weight, the height and the mid upper arm circumference are the most commonly used, but skin-fold thickness and various other measurements are sometimes used.

Weight

A 25 kg hanging spring scale, graduated by 0.100 kg, is used. The scale is hooked to a tree, a tripod or a stick held by two people.

The weighing pants are suspended from the lower hook of the scale, and the scale is readjusted to zero. The child's clothes are removed and the child is placed in the weighing pants. The pants then hang freely from the hook. In cold countries or in certain cultures it might be impossible to undress a child. The average weight of the clothes should be evaluated and deducted from the measure. When the child is steady, the weight is recorded to Adapted from How to weigh and measure children, UN, 1986 the nearest 100 grams - the scale should be read at eye-level.



Figure 6 : *Weight assessment*

FIGURE

Figure 6: Weight assessment

If the child is moving and the needle does not stabilize, the weight should be estimated by recording the value situated at the mid-point of the range of oscillations. The measurer announces the value read from the scale, the assistant

repeats it for verification and records it on the questionnaire.

Every morning the scale should be checked against a known 10 kg weight. If the measure does not match the weight, the scale should be discarded or the springs must be changed.

Height

Children aged more than 2 years old are measured standing up. Children less than 2 years old are measured lying down. If the age is difficult to assess, children of more than 85 centimetres are measured standing, those less than or equal to 85 centimetres, lying down.

· For children of more than 2 years, the measuring board is set up in a place where there is room for movement. The child's shoes are removed. The child is placed on the measuring board, standing upright in the middle of the board. The child's ankles and knees should be firmly pressed against the board by the assistant while the measurer positions the head and the cursor.

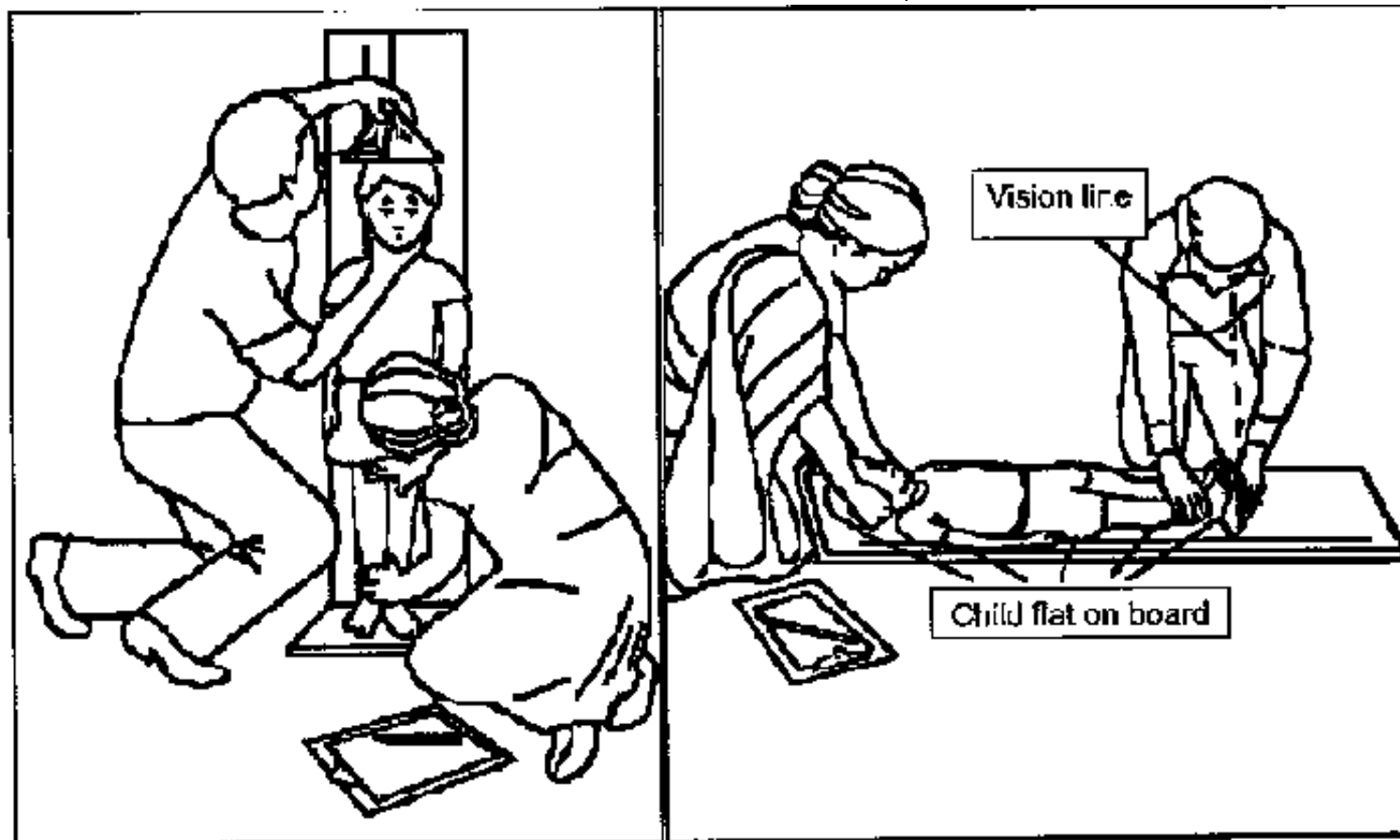

Figure 7 : Height assessment in standing position

Figure 8 : Height assessment in lying position

FIGURE height assesment

- The child's head, shoulders, buttocks, knees and heels should be touching the board. The measurer reads the measure to the nearest 0.1 centimetre. The assistant writes down the measurement and repeats it to the measurers to make sure it has been correctly heard and recorded.
- For children of less than 2 years old, the measuring board is placed on the ground. The child is gently placed, lying down the middle of the board. The

assistant holds the sides of the child's head and positions the head until touching the foot board. The measurer places his hands on the child's ankles or knees. While positioning the child's legs, he positions the cursor up against the bottom of the child's feet, which should be at right angles. He reads the measure. The remaining procedures are the same as for standing children.

Age

If birth dates have been recorded on a health card or immunization card, determination of age is simple. In such cases, the date of birth is directly recorded onto the questionnaire in order to avoid mistakes in calculating the age. If birth dates are not recorded, a local calendar of events is used. The mother is asked whether the child was born before or after certain major events until a fairly accurate age is pinpointed. If that is not possible, children are selected on the basis of height. Only children more than 65 centimetres and less than 110 centimetres tall should be included in the sample.

Oedema

In order to determine the presence of oedema, normal thumb pressure is applied to the foot or the leg for three seconds (3 seconds is approximately the time necessary to say one thousand and one, one thousand and two, one thousand and three). If a shallow print or pit remains when the thumb is lifted, then the child has oedema. Nutritional oedema should be found on both feet or legs. Only children with oedema on both feet or legs are classified as having nutritional oedema.

Mid upper arm circumference (MUAC) (see Ref. 14, 15,18, 20)

Mid upper arm circumference is measured on the left arm, at the mid-point between the elbow and the shoulder.

The arm should be relaxed. A special measuring tape is placed around the arm. The measurement is read from the window of the tape without pinching the arm or leaving the tape loose. The mid upper arm circumference is recorded to the nearest 0.1 centimetre (see Annex 2).

Various indices and their meaning

None of these parameters, except mid upper arm circumference, give information about nutritional status when taken alone. They should be related to each other in order to define indices. The weight is related to age: weight/age index; the weight with the height: weight/height index; the height with the age: height/age index.

THE CONCEPT OF A REFERENCE POPULATION

The indices are compared to values for a reference population to see if they are worse than expected from the reference. For the same age, the height or the weight of a child from the sample is compared to the height or weight of the children of the reference population. For the same height, the weight of a child from the sample is compared to the weight of the children from the reference population. Reference tables have been drawn up for both sexes. For field use, sex combined tables have also been drawn up (see Annex 13).

These reference values for the various indices have been calculated from data

collected by the National Centre for Health Statistics (NCHS) in the United States of America. This reference population, composed of young Americans, should not be considered as reflecting an <<ideal>> nutritional status, but should be used as a tool which allows comparison of data sets against a standard. It is then possible to compare the nutrition status from samples from two different countries, or the nutritional status of one population over a certain time period. Local reference curves exist in some countries. They can be used locally, but results should also be presented using international NCHS curves in order to allow international comparisons.

MODIFICATION OF THE WEIGHT AND THE HEIGHT

The weight of a child can change substantially in a short period of time. Hence, a child exposed to nutritional stress may lose up to 20% of his body weight within a few weeks. In contrast, height cannot change to the same degree. The height of a child cannot be reduced, but the speed of growth may be slowed down. In the same way, a decrease in weight can be corrected rapidly if the nutritional situation improves, whilst the effected height can only be corrected in a small proportion of children. These are the reasons why each index has a different meaning.

MEANING OF THE INDICES

The weight / age index

The weight for age index expresses the weight of a child in relation to his age. However this index does not allow differentiation between two children of the same age and weight, one being tall and thin (wasted), the other shorter but not

wasted. This index is mainly used during Maternal and Child Health clinic visits, since it is a good way of assessing the nutritional evolution of a child over time.

The height / age index

The height/age index expresses the height of a child in relation to his age. It reveals stunting at a given age, but does not allow discrimination between 2 children of the same age and height, one being thin (wasted) the other one being heavier. This index reflects the past nutritional history of a child rather than his current nutritional status. It is mainly used to identify chronic malnutrition.

The weight / height index

The weight/height index expresses the weight of a child in relation to his height. It reveals whether a child is thin or not but does not discriminate between 2 children of the same height and weight, one being older than the other, and possibly stunted. It is the index used to measure acute malnutrition called "wasting", meaning current or acute malnutrition at the time of the survey.

Mid upper arm circumference

The mid-arm circumference is almost stable from 6 to 59 month and hence does not need to be related to the age. But it is less reliable to measure and so it is only used for the rapid screening of populations to get an idea of the situation and for entry to nutrition programmes. We will not consider MUAC as a tool to assess nutritional status in this part.

In emergency situations where acute forms of malnutrition are the predominant

pattern, the weight for height index (W/H) is the most appropriate index to quantify levels of current acute malnutrition in the population with an assessment of oedema. Furthermore, weight for height does not require the determination of age which is often difficult in these situations. (Ref. 15,18, 20).

Calculation and expression of the indices

Indices can be calculated by using reference tables or by using appropriate computer software.

NORMAL DISTRIBUTION CURVE

For a given height, one can draw the distribution curve of the children according to their weight. This bell shaped curve is called Gauss's curve or the normal distribution. It has some specific characteristics. The curve is symmetrical around the mean weight, the mean weight being the sum of all weights divided by the number of observations. The mean weight is equal to the median) weight, the median weight being the weight which splits the sample in two parts of equal size according to weight. This curve can be defined by its mean weight and its standard deviation.

The standard deviation is the square root of the sum of the squares of the differences between each weight and the mean weight, divided by the number of observations minus one.

Standard deviation = $\sqrt{\text{sum (observed weight - mean weight)}^2 / (n-1)}$

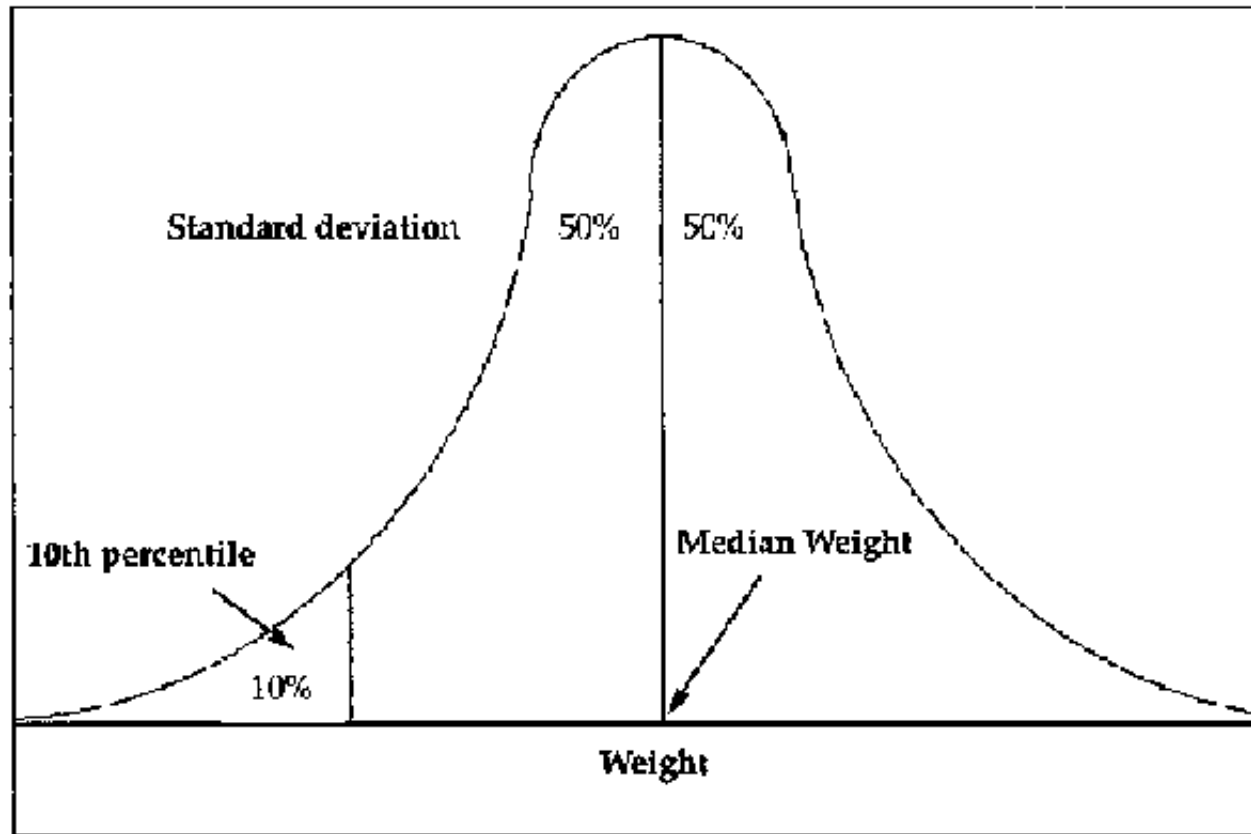

Figure 9: Normal distribution curve

FIGURE

In fact, it is not exactly the case for a distribution according to weight for a given height. The distribution is slightly asymmetrical, because weight variations are greater in the upper part of the distribution. This is the reason why we will deal with the median rather than the mean, since it is a better indication of the distribution for weight for height.

Expression in percentage of the median

This mode of expression requires knowing the median weight of the children of the reference population of the same length/height. The value of the median weight can be found in reference tables for each height by 0.5 cm. Calculation is simple: the observed weight is divided by the median weight and multiplied by 100 in order to be expressed as a percentage of the median.

Weight / height index = Observed weight / Median weight x 100

For example, for a child of 80.5 cm weighing 9.6 kg, reference tables give a median weight of 10.9 Kg. The weight/height index expressed in percentage of median is:

$$9.6 / 10.9 \times 100 = 88.1\%$$

Expression in percentiles

In the reference population, for a given height/length, the weight of children aged between 6 to 59 months is normally distributed. The 50th percentile is the weight which divides the distribution into two equal parts, 50% above, 50% below. It coincides with the median weight. In a similar way one can define the 10th percentile as being the weight under which 10% of the children of the reference population lie (90% being above). In the survey sample, for a given height/length, one can express the weight of a child according to its position in the reference distribution. The various weights corresponding to the various percentiles are shown by the reference tables.

For example, for a child weighing 9.6 kg and measuring 80.5 cm, the tables show weight values corresponding to the 5th percentile, the 3rd percentile as well as

the deciles in the reference population. By reading the table, the weight of the child can be expressed as corresponding to the 5th percentile.

For the whole sample, one can determine the number and thus the proportion of children situated below a given percentile. When one says that in the sample 12% of the children were found to have an index below the 3rd percentile, it means that where 3% of the children from the reference population are found below this weight, 12% are found in the sample.

Expression in Z-Scores

The expression in Z-Scores uses the standard deviation of the reference distribution for a given height/length as a unit. The weight/height index expressed in Z-Scores represents the difference between the observed weight and the median weight of the reference population expressed in standard deviation units:

Weight/height index = (Observed weight - Median weight) / Standard deviation

Reference tables give the standard deviation and the median weight for each given height/length. This allows us to calculate, for each child in the sample, the value of his index expressed in Z-Scores. For example, for a child 80.5 cm and 9.6 kg, reference tables show a median weight of 10.9 Kg and a standard deviation of 0.870 kg². Hence, his index expressed in Z-Scores is:

WHICH MODE OF EXPRESSION SHOULD BE USED?

(9.6 - 11.0) / 0.870 = -1.61 Z-Scores

Expressions in percentiles and Z-Scores have a true statistical meaning, which percentage of the median does not have. A child is more malnourished if the weight/height index is 80% at 6 months than at 59 months. The expression in percentiles does not allow the identification of severely malnourished children since percentiles corresponding to severely malnourished children do not exist in the reference population. Expression in Z-Scores is recommended. However, if people in charge of the refugees or people going to use the information are used to another mode of expression, this should also be used in order to deliver meaningful information.

CALCULATION OF THE INDICES

Calculations do not need to be carried out in the field when collecting the measurements. The main aim of the survey is not to locate malnourished children (screening) but to gather information on the whole population. The major preoccupation is not individuals but rather the condition of the population. If a child is found to be obviously malnourished during the course of the survey, he has to be referred to an intensive nutrition unit in order to seek treatment, but this is not the objective of the survey.

If computer equipment is available, one of the existing anthropometric software packages maybe used for calculation and analysis of the results (see Ref. 21). Data is directly entered into these software packages and nutrition indices are calculated by the programme, thus avoiding mistakes in reading the tables. Computerization of the nutrition indices is more accurate than manual calculation and takes into account the sex of the children.

If computer equipment is not locally available, reference tables can be used (see Annex 13). They are derived from the NCHS reference curves and are valid for both sexes. The height/length is rounded to the nearest 0.5 cm, as shown in the next table.

Measured height	Rounded height
80.8	
80.9	
81.0	81.0
81.1	
81.2	
81.3	
81.4	
81.5	81.5
81.6	
81.7	
81.8	
81.9	82.0
82.0	
82.1	
82.2	

FIGURE

Weight values corresponding to the different cut off values are read from the table, enabling us to classify a child as belonging to an interval of the percentage of the median. For example a child 80.5 cm tall and weighing 8.6 kg will qualify for the interval of 75% to 80% of the median. Similar tables exist for Z-Score

classification (see Annex 13).

We will only focus on the weight/height index in this part, since it is the most appropriate for assessing acute malnutrition and thus in meeting the objectives of a nutrition survey in emergency situations.

3. Sampling methods

Principles of sampling

If all individuals in a given population were surveyed, we would get a precise picture of the nutritional status of this population. An exhaustive survey of this type would be long, costly and difficult to carry out. This is why measurements are only recorded for a sub-group of the population, called a sample, which "represents" the whole population. In fact, only children aged 6 to 59 months (65 -110 cm) are included in the target population, since it is this group which will best reflect the nutritional status of the population. Children in this age group are in a growing period, hence a modification in the availability of food will affect them first. It is from this sub-group that the sample is selected.

If the main objective of the survey is to compare two groups according to their nutritional status, two different surveys, one for each group, are required.

REPRESENTATIVENESS OF THE SAMPLE

The representativeness of a sample is essential. It is the prerequisite for extrapolation of results observed for the sample to the entire population. In order for a sample to be representative of the population, two criteria should be met:

each individual should have an equal chance of being selected for the sample, and the selection of one individual should be independent of the selection of another individual.

PROBABILITY

Whenever a sample is drawn, a probability of error exists, meaning that there is a risk that the sample may not be truly representative of the population. In nutrition surveys, we accept an error risk of 5%. This means that we accept that in 5% of the surveys, results observed for the sample will not reflect the true nutritional status of the population. In other words, whenever an organization carries out 100 nutrition surveys, 5 of them will give a result not reflecting the true situation.

PRECISION, THE CONFIDENCE INTERVAL

By carrying out measures on a sample of the population, we only get an estimation of what the results would be if they were carried out on the entire population. If a second sample is drawn out of the same population, slightly different results may be obtained just because of the variation of the children selected for the samples.

The actual percentage of malnutrition in the entire population lies in a range around the observed value. The upper and lower limit of this range determines the confidence interval of the estimation. For example results will be expressed as follows: malnutrition rate = 13% + 5%, meaning the confidence interval ranges from 8% to 18%. The size of the confidence interval is related to the error risk and the size of the sample.

SAMPLE SIZE

The sample size is related to three factors:

The expected precision: the greater the precision desired, the more people needed in the sample.

The probability of error chosen: the smaller the probability, the more people needed in the sample. If the whole population is surveyed, the probability is zero. In nutrition surveys, an error risk of 5% is accepted.

The expected prevalence: the nearer the expected proportion of children presenting malnutrition is to 50%, the greater the size of the sample required, for the same absolute precision.

Furthermore, a fourth factor should be taken into consideration:

The available means: the ideal objective in determining the sample size is to have the highest precision for the smallest error risk. The limiting factor is the available means. How many children can reasonably be surveyed in a day? How many data collectors are available?...

In conclusion, measuring malnutrition in a sample gives values affected by a known and accepted margin of error. On the other hand, sampling reduces the workload and allows surveys to be carried out in a short period of time.

Calculation of the sample size

When calculating the size of the sample the three factors previously defined should be taken into consideration. The formula used is the following *:

$$n = t^2 * (p * q) / d^2$$

n = sample size

t = parameter related to the error risk, equals 1.96 or 2 for an error risk of 5%

p = expected prevalence of malnutrition in the population, expressed as a fraction of 1

q = 1 - p, expected proportion of children not presenting malnutrition, expressed as a fraction of 1.

d = absolute precision, expressed as a fraction of 1.

Practically:

<<t>> is fixed 1.96 (or 2) in this type of survey (corresponding to an error risk of 5% 3).

<<p>> and thus <<q>> (q = 1-p) are estimated from previous surveys. The expected prevalence is always chosen to be closer to 0.5 (50%) than truly expected order to get a bigger sample size. If we have a larger sample size than needed, we are sure of getting at least the desired precision even if the measured prevalence is larger than expected. A short survey of 30 households can give an idea of the expected prevalence if no information is available prior lo the survey

<<d>> is a parameter that can be modified (<<t>> is constant, <<p>> is estimated The factors which are considered in determining <<d>> are: the

objectives of the survey the expected prevalence and the available means.

If the main objective of the survey is to demonstrate a moderate difference in the nutritional status between two groups, or over a certain period of time, the precision will have to be high (and therefore, <<d>> very small).

Usually, in nutrition surveys, the expected prevalence ranges from 5% to 20%.

The precision should be proportional to the expected prevalence. For example, 10% precise for an expected prevalence of malnutrition of 10% will give a confidence interval from 0% to 20%. No conclusion can be reached from such results. Refer to the next table in order to see how the precision affects the sample size for digit levels of expected malnutrition.

**Sample size according to the expected prevalence and the precision
in a random or systematic sampling with a 5% error risk**

Prevalence	Precision				
	1%	2%	3%	4%	5%
5%	1825	456	203	-	-
6%	2167	542	241	135	-
7%	2501	625	278	156	100
8%	2827	707	314	177	113
9%	3146	787	350	197	126
10%	3457	864	384	216	138
11%	3761	940	418	235	150
12%	4057	1014	451	254	162
13%	4345	1086	483	272	174
14%	4625	1156	514	289	185
15%	4898	1225	544	306	196
16%	5163	1291	574	323	207
17%	5420	1355	602	339	217
18%	5670	1418	630	354	227
19%	5912	1478	657	370	236
20%	6147	1537	683	384	246

FIGURE

For example, in a survey where the expected malnutrition rate is 15% (12% from a previous survey), and with a desired precision of 3%, the sample size is:

$$n = 1.96^2 * 0.15 * 0.85 / 0.03^2 = 544$$

The size of the target population does not usually effect the required size of the sample. This is true when the size of the population is much larger than the size of the sample. However, if the sample size approaches the size of the population, a correction factor can be applied to the formula. It reduces the required sample size needed to get the chosen precision. This correction factor is used whenever the sample size is more than one tenth of the total population. The revised sample size is given by the following formula:

$$\text{Revised } n = n / (1 + (n/N))$$

In our example, if the total population of children aged 6 to 59 months was 5000, the revised sample size would be:

$$\text{Revised } n = 544 / (1 + 544/5000) = 490$$

Sampling methods

Three main sampling methods are available: random sampling, systematic sampling d cluster sampling.

RANDOM SAMPLING

Random sampling is the best method, when it can be used, since it is the only one meeting the two criteria for representativeness as previously defined. A sampling base should be available which lists every individual in the population and allows you to locate them. The list must be kept up to date with regard to the ages and

location of each individual and include all new births. Individuals are randomly drawn from the list using a random number table (see Annex 10). Most of the time, such a list is not available or reliable.

SYSTEMATIC SAMPLING

Systematic sampling is a method in which the geographical organization of the area to be surveyed is used. Every household should have the same chance of being surveyed by a team going across the whole area. Then one household out of X is visited. This technique can often be used in well organized refugee camps where houses are arranged in blocks and lines. In the same manner, if houses are enumerated, it is possible to survey one household out of X number, going across the camp from one extremity to the other.

TWO STAGE CLUSTER SAMPLING

This method is used when the two previous ones are not possible: no register is available and the geographical organization of the area does not permit a visit to all houses. The population is grouped in smaller units for which the population sizes can be estimated. The smallest unit for which the population can be estimated should be chosen as the sampling base. These units may be villages, city blocks or sections of a camp. Thirty clusters are randomly drawn (first level of sampling), in each cluster a certain number of children will be selected and surveyed (second level of sampling). The chance for each unit to be selected is proportional to its population size.

This sampling technique does not meet the second criteria for representativeness.

The fact that several children are selected within a cluster by proximity means that the choice of a child is not independent from the choice of other children. Within each cluster children will have a tendency to be more similar, as far as nutritional status is concerned. This phenomenon is called the <<Design effect>>. The design effect is taken to account when calculating the sample size by multiplying the result obtained through the formula by 2. It means that when cluster sampling is used, the survey should use a sample size twice as large as for the other two sampling methods to reach the same level of precision.

WHICH METHOD TO CHOOSE?

Whenever a reliable register is available, random sampling is preferred. When populations are living in small, well defined geographical areas, systematic sampling should be chosen. In other instances, a two stage cluster sampling strategy should be applied.

Realization of the sampling

RANDOM SAMPLING

Random sampling implies the existence of a sampling base, such as a register. The steps are as follows:

- calculation of the sample size:**

The following information is required:

- expected prevalence of malnutrition: for example $p = 0.15$ (15%)**

- **error risk: 5%, meaning $t = 1.96$**
- **precision wanted: $p = 0.03$ (3%)**

The sample size is:

$$n = 1.96^2 * 0.15 * 0.85 / 0.03^2 = 544$$

- **a serial number is given to each child. For example, in a population of 12,481 children, a serial number between 00001 and 12,481 is attributed to each child.**

Refugees Register book			
Children from 6 to 59 months			
1	Gonzalo B.	21	Adriana V.
2	Alberto T.	22	Angel P.
3	Sonia X.	23	Mercedes S.
4	Isabel Z.	24	Atahualpa Y.
5	Anthon G.	25	Victor N.M.
6	Amanda J.	26	Yoav C.
7	Roberto A.	27	Dantel V.
8	Eljanan C.	28	Horacio G.
9	Denis B.	29	Claudia O.
10	Javier K.	30	Maria D.F.
11	Jennifer A.	31	Josep N.
12	Barnabé F.	32	Mario A.
13	Francisco J.	33	Bernardo P.
14	Pedro M.	34	Rosina M.
15	Martin L.	35	Luis L.
16	Monica U.	36	Joao P.
17	Juan X.	37	Vinicius M.
18	Alvaro T.	38	Toquinho G.
19	Gabriel P.	39	Esteban R.
20	Jorge L.	40	José Maria P.
		41	Rosario A.N.
		42	Graciela M.

Figure 10 : Random sampling

FIGURE

- draw numbers from the list using a random number table until the required number of children is selected. For example, the table may generate the following

random numbers: 00002, 00006, 00013, 00017, 00023, ..., 11,872, ...

Children corresponding to these numbers are included in the sample.

SYSTEMATIC SAMPLING

Systematic sampling is used in relatively small geographical areas. The draw is based on a register of families or on the spatial arrangement of households. The organization of the site should allow one to comprehensively cover all houses. This technique is particularly adapted to well organized refugee camps. The steps for systematic sampling are as follows:

- Determine the number of inhabitants and the number of households: For example let's consider a camp of 50,000 refugees and 11,000 households.**
- Determine the number of children between 6 and 59 months of age**

The proportion of children between 6 and 59 months is quite stable, usually around 20%. However in certain situations, when a high infanto-juvenile mortality is suspected, this proportion can be smaller. The proportion of children has to be estimated from a rapid survey covering about 30 households selected at random.

In our example we have an estimate of 10,000 children (20% of 50,000).

- Calculation of the sample size**

The same calculation as for random sampling is used: $n = 544$.

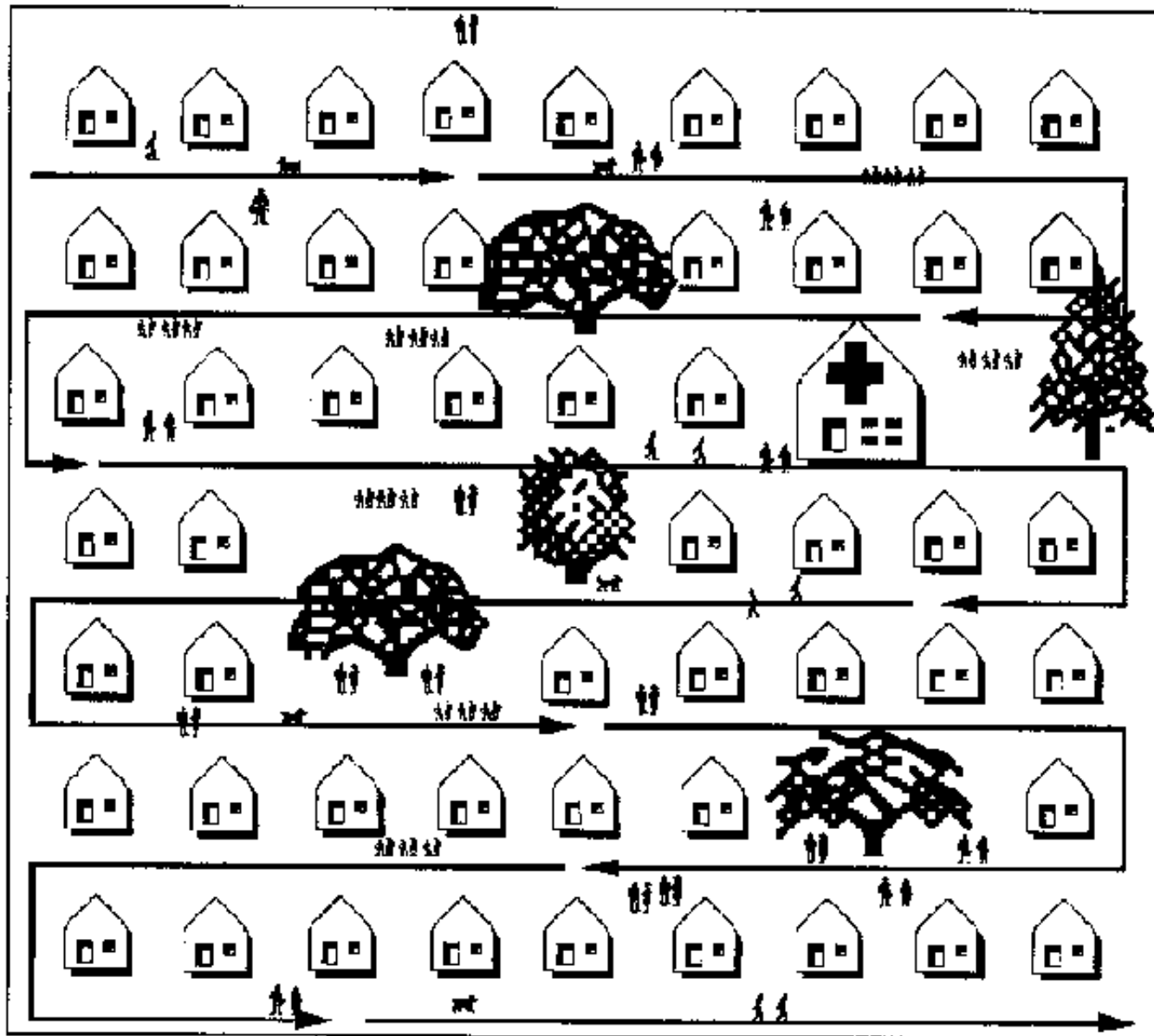

Figure 11 : Systematic sampling, example of drawing 1 household every 7 households, starting with household N°4.

FIGURE

- **Determine the required number of households**

The first step is to calculate the average number of children by household. It is equal to the total number of children divided by the number of households: $10,000/11,000 = 0.9$. Therefore, 604 households ($544/0.9$) will have to be visited in order to complete the sample.

- **Determine the sampling interval**

This is calculated by dividing the number of households by the number of households required in the sample. In our example: $11,000 / 604 = 18.2$. One household every 18 households will be visited and all children (between 6 and 59 months) found in these households are included in the sample.

- **Determine the first household to visit**

The first household is randomly selected in the first interval, 01 to 18, using a random number, 05 for example.

- **Selection of the households**

One household is then selected, starting with the fifth one, then the twenty-third ($18 + 5$), the forty-first, etc.....

If two eligible children are found in a household, both are included in the sample. If no children are found in one household, the closest household (or as found using the sampling interval) is visited. If a child is not present at the time of the visit, the data collectors will have to come back to this very household in order to

measure the child.

It is important not to overestimate the proportion of children aged 6 to 59 month when calculating the sampling interval. If this were the case, the sampling interval would be too large and the sample would not reach the desired size.

CLUSTER SAMPLING

The steps for 2 stage cluster sampling are as follows:

- Determine the geographical units and their population**

Cluster sampling requires the grouping of the population in smaller geographical units. The smallest available geographical unit is always chosen as long as its population can be estimated. For each of these units the population of children 6 to 59 months is estimated.

These units can be villages, sections of the camp, or naturally defined geographical areas (river, road,...). In the rest of our example we will refer to these geographical units as sections.

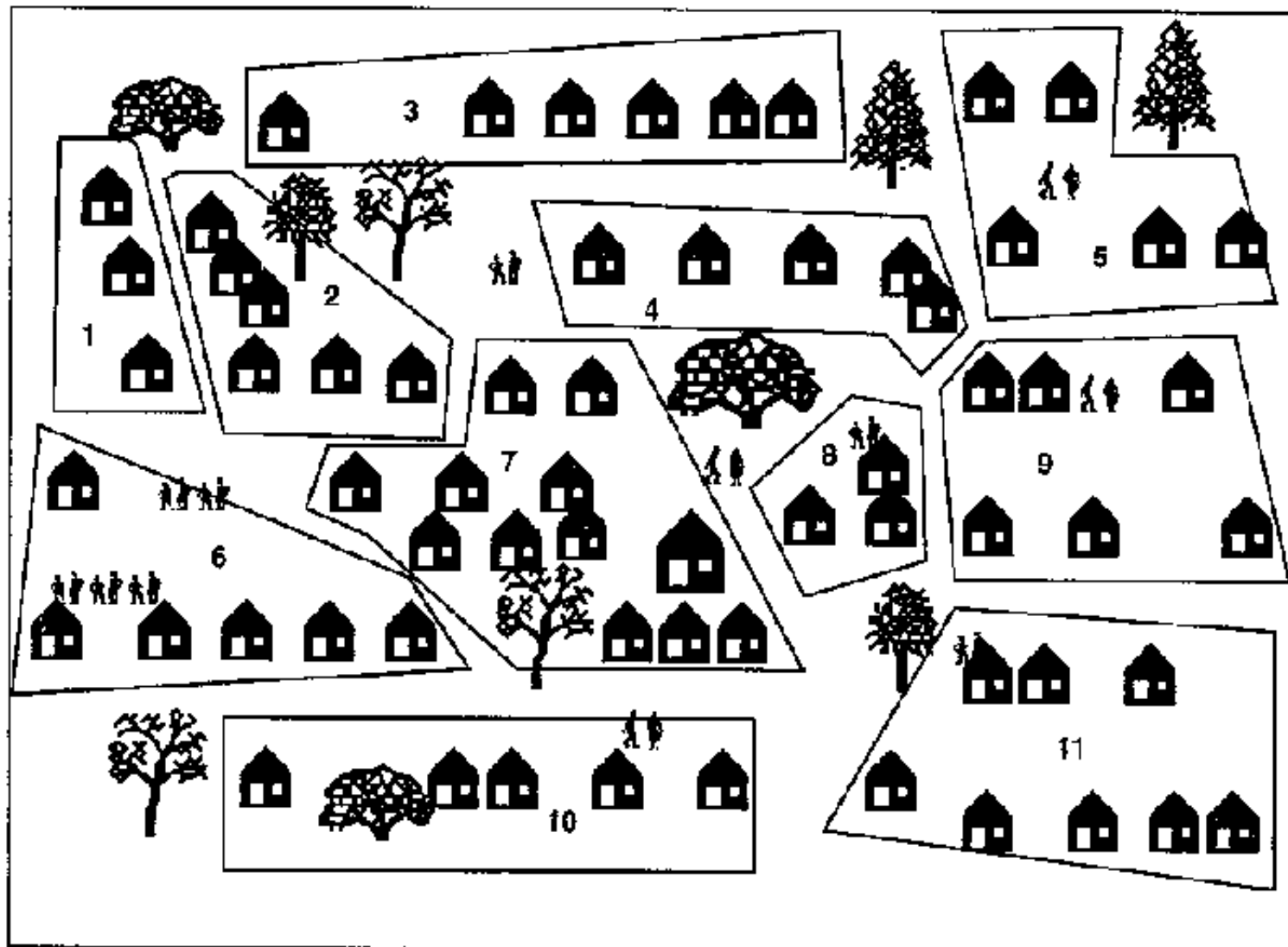

Figure 12 : Cluster sampling, regrouping of the area into smaller zones.

FIGURE

• Calculation of the sample size

The calculation of the sample size uses the same formula as for random or

systematic sampling. However, the size of the calculated sample should be doubled to take into account the design effect. A minimum of 30 clusters is always required. In each of these clusters, the number of children to be selected is the sample size divided by the number of clusters. For example, in a survey where the expected prevalence of malnutrition is 20%, the required precision 4%, 2 times $384 = 768$ children are required. Hence, in each cluster, $768/30 = 26$ children will be included.

· Calculation of the cumulative population

Sections	Estimated total population	Estimated 6-59 month population	Cumulative population	Attributed numbers	N° Clusters per section
Section N°1	2,500	500	500	1 - 500	1
Section N°2	2,000	200	700	501 - 700	1
Section N°3	800	160	860	701 - 860	0
Section N°4	3,250	670	1,610	861 - 1,510	2
• •	• •	• •	• 10,000	• - 10,000	
Total	50,000	10,000			

FIGURE

A list of the sections is established, as well as their respective population. In a third column, the cumulative total is calculated by adding the population of each unit to the sum of the population of the preceding sections. In other words, it is as

if each section was given a certain amount of points, proportional to its population size.

- **Calculation of the sampling interval**

The sampling interval, in cluster sampling, is the total population divided by the number of clusters, usually 30. The thirty clusters are selected using the sampling interval. In our example, the sampling interval is: $10,000 / 30 = 333$.

- **Determination of the location of the first cluster**

The location of the first section to appear in the sample is randomly selected within the first sampling interval. If the drawing of the first cluster was done from the beginning of the list, the first section would always appear in the sample, which would not give each section the same chance of being selected. A random number is used (Annex 10), in our example, between 001 and 333. Let's say the random number drawn is 256.

- **Selection of the clusters**

The sampling interval is added to this random number and the first cluster is selected in the section which includes this number. In our case, section No 1 includes 256, and so is the first section to be included, followed by section No 2: 589 (333+256), section No 4: 922 (589 + 333), section No 4 again: 1,255, etc...

A large section may appear twice - two clusters should be drawn in section No 4. In the same way, a small section (smaller than the sampling interval) may not be selected - section No 3 in our example.

· **Selection of children in the clusters**

Having identified the thirty clusters, a team of data collectors goes to the centre of the selected section. A random direction is picked by spinning a bottle. The bottleneck indicates the direction. A surveyor goes in that direction, from the centre to the border of the section, while counting the number of households he encounters. The first household to be visited is randomly selected from among these households by drawing a random number. A sketch of these households can be used.

The subsequent households are chosen by proximity. The next nearest household available is selected until the required number of children has been measured.

All eligible children are included and thus should be measured and weighed. If a child is not present when the team passes, he has to be found, or the team must come back later to measure this child. If a child has been admitted to an intensive feeding centre, the team must go to the centre and measure him there.

4. Analysis, interpretation and recommendations

The analysis is composed of two parts:

- **A descriptive analysis, which consists of building distributions according to the variables.**
- **An interpretive analysis where cross tabulations are used to make comparisons between groups.**

The analysis uses the weight/height index values. There are two approaches when analysing and presenting results:

- the first approach estimates the proportion of children with W/H index falling below a cut off value.**
- the second approach describes the whole distribution of children according to index values (= standard prevalence).**

These two approaches are complementary. If the survey's objectives are to quantify the number of children who may benefit from an intensive feeding programme or from supplementary rations based on a cut-off value of the index, the first approach is the most appropriate.

However, if the objective is to assess the overall impact of a programme on the whole population of children, the second approach is preferred.

In this Part, we will only develop the first approach.

Description of the sample

The first step in the analysis is to describe the sample, by describing the distribution of characteristic variables. This will indicate if the sample is made up from eligible children. For example, a distribution according to age will give the proportion of children less than 6 months or more than 59 months, which should not have been included in the sample. An age pyramid can demonstrate an under-representation of an age group in the sample (see Annex 9).

An under-representation of an age group, such as the 6-17 months group, in the sample may reflect a higher mortality in this subgroup, but may also reflect the fact that these children were not present on the day of the survey.

In the same way, a distribution according to sex allows us to verify that both sexes are equally represented, and hence, that no selection bias has occurred.

A cluster sample survey has been carried out. The expected prevalence was 12%, the desired precision was 4%. The required sample size was $254 \times 2 = 508$ children, implying 30 clusters of 17 children (510 children). The following distribution according to age and sex was observed.

Expression of results with their confidence intervals

The age classes proposed here are centred around the months representing full years: 12 months (6 - 17 months), 24 (18 - 29), 36 (30 - 41) and 48 (42 - 32) months. Many ages are mis - reported and age biasing is toward the full years (i.e. the child is 1 year if it is really 10 months). Making age classes around the full year months is meant to evenly distribute peaks of distribution usually seen around these values

In our example the distribution by sex is not statistically different from an even distribution.

In our example, W/H and oedema were distributed as follows:

Definition of nutrition indicators

The two main signs of acute malnutrition described in the chapter concerning the antropometric measures are: a decrease in the value of the W/H index and the presence of oedema. The combination of these two signs and a cut off value for the index are used to define 2 classes of malnutrition:

Global acute malnutrition: proportion of children with a weight / height index <- 2 Z-Scores or oedema

Severe acute malnutrition: proportion of children with a weight / height index <- 3 Z-Scores or oedema

Calculation of malnutrition indicators

To start with, the number of children presenting with oedema is calculated (2 in our example). Then the number of children presenting with a weight / height index <- 3 Z-Scores and not presenting oedema is calculated. These two numbers are added in order to determine the total number of children with severe acute malnutrition (5 in our example). This number is then expressed as a proportion of the total number of children ($5/510 = 10\%$)

Then these steps are repeated using - 2 Z-Scores as the cut off, in order to determine the number of the children who are defined as globally acutely malnourished (39 in our example). Again this result is expressed as a proportion of the whole sample ($39 / 510 = 7.6\%$).

In our example, the following figures are obtained:

Oedema	2	Oedema	2
--------	---	--------	---

Index <- 3 Z-Scores	3	Index <- 2 Z-Scores	37
Numerator	5	Numerator	39
Denominator:	510	Denominator:	510
Severe acute malnutrition:	1.0%	Severe acute malnutrition	7.6%
Oedema + index <-3 Z-Scores		Oedema + index <-2 Z-Scores	

	Weight/height index	
	< -2 Z-Scores	≥ -2 Z-Scores
yes	Marasmus/Kwashiorkor 1 0.2%	Kwashiorkor 1 0.2%
no	Marasmus 38 7.3%	Normal 470 90.4%

FIGURE

When calculating the sample size, the notion of precision was introduced. This is the reason why the proportion of children presenting with malnutrition should be expressed with a corresponding precision which determines the 95% confidence interval. The confidence interval is the prevalence found plus or minus the precision achieved. Calculation of the precision uses the formula already used for determining the sample size but in another way. As a matter of fact, when

calculating the sample size (n), an expected prevalence (p) was estimated and a desired precision (d) was used. Now that the survey has been carried out, the approach is reversed: the sample size is known, and the prevalence has been measured, what is going to vary is the precision achieved. If the observed prevalence is closer to 50% than the predicted one, the precision will be worse than expected. If the observed prevalence is less than expected, the precision will be better than expected. This highlights the importance of overestimating the expected prevalence when calculating the sample size, in order to be on the safe side when the survey is completed. Formula for calculation of random/ systematic survey precision:

$$d = t * \text{sqrt}(p * q/n)$$

The above formula concerns random sample or systematic sample surveys. In a cluster sample survey, the exact formula for the precision uses the prevalence observed in each of the clusters in order to take into account the design effect.

Formula for calculation of cluster survey precision:

$$d = 1.96 * \text{sqrt}(\text{sum}(p_i - p) ^ 2 / ((k * (k - 1))))$$

d: precision

p_i: proportion observed in the cluster i

p: proportion observed in the whole sample

k: number of clusters

In fact, unless a computer is available, a more simplified formula is used in estimating precision for cluster surveys, assuming a design effect of 2. Simplified formula for calculation of cluster survey precision:

$$d = t * \text{sqrt}(2 * p * q/n)$$

The confidence interval for the estimation of malnutrition is the observed prevalence plus or minus the precision as calculated above. The confidence interval has a 95% of chance of including the actual proportion of malnutrition in the whole population.

In our example, calculation of the precision gives the following:

$$d = 1.96 * \text{sqrt}(2 * 0.076 * 0.924/510) = 0.033$$

Therefore, a 95% confidence interval is:

$$\text{C.I.} = p + d$$

Results would be presented as follows:

510 CHILDREN AGED 6 - 59 MONTHS

Proportion of children with oedema = 0.4%

Global acute malnutrition defined by an index < -2 Z-Scores or presence of oedema: 7.6%

95% confidence interval of this estimation: 4.8% to 10.9% (7.6 + 3.3%).

Severe acute malnutrition defined by an index < -3 Z-Scores or presence of oedema: 1.0%

95% confidence interval of this estimation (corrected): 0.2% to 3.4%.

From these two proportions, we can estimate the actual number of malnourished children in the population. The proportions can be applied to the number of children in the population. In our example we estimate the total number of globally acutely malnourished children in the population to be between 430 (4.3% of 10,000) and 1090 (10.9% of 10,000); and between 20 (0.2% of 10,000) and 340 (3.4% of 10,000) children are severely acutely malnourished.

These results can also be expressed for a sub-group of the children, based on age, in order to avoid masking malnutrition in this group by including them in a broader group.

252 CHILDREN AGED 6 - 29 MONTHS

Global acute malnutrition defined by an index < -2 Z-Scores or presence of oedema:10.7%

95% confidence interval of this estimation: 5.3% to 16.1%

Severe acute malnutrition defined by an index < -3 Z-Scores or presence of oedema: 0.8%

95% confidence interval of this estimation (corrected): 0.0% to 5.2%.

Expression of results with their confidence intervals

NOTE 1:

If a correction was used for calculating the sample size because the sample was more than 10% of the size of the total population, the value of n appearing in the above formulae should be the one before the correction in order to calculate the precision.

NOTE 2:

A corrected formula exists (quadratic method) which should be used for proportions close to 0% or 100%:

$$\text{Lower limit} = ((2 np + t^2 - 1(t^2 - (2 + 1/n) + 4p(np + 1))^{1/2})/2(n + t^2)$$

$$\text{Upper limit} = ((2 np + t^2 + 1) + t(t^2 + (2 - 1/n) + 4 p (np - 1))^{1/2})/2(n + t^2)$$

t: error risk = 1.96

n: sample size

p: proportion of children with malnutrition

q = 1 - p: proportion of children without malnutrition

INTERPRETIVE ANALYSIS

Some variables can be cross-tabulated. For example, nutritional status (defined according to a cut off value of the weight/height index) and the date of arrival in the camp.

Nutritional status according to the date of arrival

Children 6 - 59 months, Region X, Period Y

Nutritional status according to the date of arrival
Children 6-59 months, Region X, Period Y

	Malnourished	Not malnourished	Total
Last arrived	25 (10.2%)	220 (79.8%)	245
First arrived	14 (5.3%)	251 (94.7%)	265

FIGURE

Such a table only gives an indication of the trend. The sample size will often not allow a stratified analysis.

Interpretation of the results in context

NOTION OF A <<SNAPSHOT>>

Figures obtained through a single cross-sectional nutrition survey only reflect the nutritional status of the population at the moment of the survey, in a certain region. Taken alone, these figures do not give any indication of the trend, whether the nutritional status is improving or deteriorating. Additional information, collected at the preparatory phase, will allow the interpretation of the results in context.

In a cluster sample survey, figures should not be analyzed for each cluster. Malnutrition observed in one cluster is never representative of the section in which the cluster was drawn, but it is representative of many similar clusters that could be drawn in different sections. As a matter of fact, it is the whole sample which is representative of the population. Practically, in order to avoid misinterpretation by people not acquainted with the cluster sampling method, results should not be presented by cluster.

INTERPRETATION IN CONTEXT

The proportion of malnutrition observed in the sample can be compared to malnutrition rates observed in a previous survey. If there is information from different surveys, some idea of the trend in nutritional status can be inferred. One can only conclude that there was a statistically significant difference between two surveys if confidence intervals do not overlap. Hence, in our example a previous survey had shown a rate of malnutrition of 15.4% + 4.4% (11.0% to 19.8%). The current situation is significantly better, since the lower limit of the first survey (11.0%) is greater than the upper limit of the current one (10.9%).

Information about infanto-juvenile mortality may suggest that a number of malnourished children have died in the past few months. The significance of the survey figures will depend on context factors such as the level of mortality and the timing of the harvest. Complementary information will help in interpreting the results. A stable nutritional situation with moderate levels of malnutrition may deteriorate rapidly if there is an outbreak of measles or a high seasonal transmission of malaria.

REFERENCE VALUES

A <<Standard recipe>> does not exist for interpreting nutrition survey results. Interpretations and recommendations cannot be based on observed figures only.

However, when the level of malnutrition reaches certain values, emergency actions have to be taken. These actions focus on the children who are classed as malnourished by anthropometric indicators as these indicators are associated to high risk of mortality. In a population where more than 2% of children present oedema, action directed towards these children should be taken without delay. In the same way, a lower limit of the confidence interval of the proportion of children presenting an index value $< - 2$ Z-Scores of more than 10% depicts an alarming situation.

INFERRING CAUSALITY

Survey results may be used to assess the current nutritional situation, to see if nutrition programme objectives have been reached and rates of malnutrition have been reduced. However, this measure of the impact of a programme does not allow us to assess the reasons for success or failure in reaching the objective. The anthropometric survey is just a tool which is part of a more global approach.

Writing of the report / recommendations

A report on the survey should be written as soon as preliminary results are available. Such a report should indicate the procedure used in defining the survey.

SUMMARY

The first page should include a short summary (1 page), covering the objectives of the survey, the methodology used, the main results and recommendations. It is meant for the use of people in charge of the population in order to make appropriate decisions guided by the findings of the survey.

INTRODUCTION

In the introduction, the context in which the survey was carried out should be described. What population was surveyed, at which period, in which geographic area.

Furthermore, any relevant information concerning the status of the population should also be reviewed. Nutrition programmes, surveillance data, morbidity and mortality information are included.

OBJECTIVES OF THE SURVEY

The objectives of the survey should be clearly stated. What was measured, in which population and why?

METHODOLOGY

- Survey methodology and sampling frame**

The choice of a cross-sectional survey is justified by the necessity for getting information in a short period of time. The sampling frame must be indicated as well as all parameters used, such as error risk, expected prevalence and expected precision.

· **Variables measured and recording information**

The type of measuring instruments used should be noted. For example, the weight was assessed using a Salter spring scale, to the nearest 100 grams.

· **Training of the data collectors**

The schedule of the training and its duration should be mentioned, including the realization of a standardization test, if it was possible.

RESULTS

Distribution of the sample, according to age and sex is the first stage of the analysis. The mode of expression of indices should be recorded as well as the definition of grades of malnutrition used. Distribution according to the indices is presented.

INTERPRETATION OF THE RESULTS, DISCUSSION

The discussion puts the results back into the context. Comparison can be made with previous surveys, or surveys from a similar situation. Tentative explanations may be suggested at this stage.

RECOMMENDATIONS

A report should always include recommendations. A nutrition survey is meant to promote rational decision making. As an example, an intensive feeding centre might be recommended in the area if the proportion of children with severe acute

malnutrition is high. On the other hand, an active screening programme through home visits can be proposed if the number of malnourished children found during the survey is much higher than the number of children currently seen in an ongoing feeding programme. A global approach might be recommended if the whole population is suffering from malnutrition. However, if the situation is demonstrated to have improved, one can recommend the interruption of a "vertical supplementary programme" and the integration of the nutrition programme in the daily MCH activities of the health system.

5. Conclusions

- Among displaced populations or refugees, evaluation of the nutritional status is essential in planning a relief programme. The measure of the prevalence of malnutrition, through a quick cross-sectional anthropometric survey gives valuable information when making decisions. The results of such a survey often have vital consequences for the community. That is the reason why these results must be reliable.**
- The reliability of the results is related to compliance with the protocol. Each step is essential.**
- The objectives should be clearly defined from the start, as should the plan of analysis.**
- The sample should be representative of the population from which it was drawn. Systematic sampling when possible gives the same precision with half the sample size required for cluster sampling.**





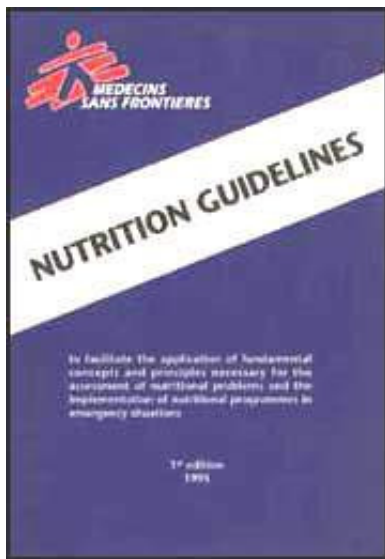

- **Measures should be reliable. Training of data collectors and assessment of their performance through standardization tests is a corner stone of the survey.**
- **The report should include a summary mentioning the main findings and the recommendations made. Confidence intervals should be indicated whenever a proportion is given.**
- **The realization of a survey in the field is an excellent occasion for health workers to appreciate the living conditions of the population. On top of the actual proportion of malnourished children given by the survey, valuable additional information maybe observed. This additional information will be of great help in appreciating a situation.**

[Home](#) > [ar](#).[cn](#).[de](#).[en](#).[es](#).[fr](#).[id](#).[it](#).[ph](#).[po](#).[ru](#).[sw](#)



Nutrition Guidelines (MSF, 1995, 191 p.)

Part III Selective feeding programmes

-  1. Justification for selective programmes
-  2. Criteria for admission and discharge to selective feeding programmes
-  3. Screening and selection
-  4. Treatment in a therapeutic feeding centre
-  5. Treatment in supplementary feeding programmes
-  6. Implementation and management of a feeding centre

-  **7. Registration and monitoring**
-  **8. Evaluation of feeding programmes**
-  **9. Food management**

Nutrition Guidelines (MSF, 1995, 191 p.)

Part III Selective feeding programmes

1. Justification for selective programmes

Proper treatment of a patient with severe Protein-Energy Malnutrition (PEM) is crucial in order to avoid death. A review of hospital treatment provided to cases with severe malnutrition demonstrated that 20 - 30% of malnourished patients die in the hospital and a further one-third die after having left the hospital (after discharge or drop-out).

Some children reach the hospital too late and die almost immediately upon arrival. However, the great majority of deaths occur after the first days of hospitalization (usually 60 -70% of deaths) and should be preventable. Home based treatment of children with severe P EM has also proved to be largely unsuccessful, with high mortality rates, high rates of non-compliance and slow recovery.

During food crises, health services risk becoming overwhelmed by large numbers of severely malnourished: a specialized nutrition rehabilitation unit or Therapeutic Feeding Centre (TFC), attached to a hospital or health centre has proven to be the most effective means of managing such situations.

Adequate treatment of severe PEM is an intensive task. A combination of good

quality medical care and a specialized feeding protocol is required.

A TFC comprises of an intensive care unit, where medical complications are treated, and where nutritional treatment is started. While in the intensive care unit, the child will receive 8 - 10 meals per 24 hours, day and night. When the child has passed the critical phase, he will be transferred to the day-care unit, which is open 8 - 9 hours a day, and where the child will receive 4 - 6 meals and medical care.

However, it is not always possible to organize a TFC in this way. Security problems, lack of competent staff or large numbers of severely malnourished children may mean that it is only possible to open day-care centres. Under these conditions, even though the intensive care of a 24-hour unit is lacking, the impact on mortality of daycare centres alone may still justify running a Therapeutic Feeding Programme (TFP).

In addition, Supplementary Feeding Programmes (SFPs) may be required to prevent moderately malnourished children becoming severely malnourished (targeted SFP) and to reduce the further deterioration of the nutritional situation (blanket SFP).

The planning and implementation of TFPs and SFPs is a step-by-step process. Although every situation has its own characteristics and requires a specific tailor-made approach, these guidelines attempt to help the reader in making decisions to design and implement different types of feeding programmes.

2. Criteria for admission and discharge to selective feeding programmes

In contrast to <<normal>> situations, where the decision to admit an acutely malnourished child to a regular hospital may be based on subjective clinical criteria, the large numbers of malnourished children needing attention during emergency situations means that admission to TFPs and targeted SFPs must be based on clearly defined objective criteria (anthropometric).

The <<cut-off points>> to be used have to be set in agreement with national relief policies, taking into consideration the capacity of the programme and the possibilities for follow-up.

Blanket SFPs must serve clearly defined vulnerable groups - the members of which must be registered in a fair and systematic way. This chapter will not deal with registration of vulnerable groups but will focus on specific individual criteria for entry to targeted feeding programmes.

Admission Criteria

Admission criteria depend on the objectives of the programme and available resources. If programme resources are not certain or limited, it is necessary to employ more restricted admission criteria. In the course of a programme, admission criteria can be changed to reflect changing circumstances like increased general food availability. Admission criteria reflect characteristics of the individual child and are based on age and nutritional status.

Children are admitted along with an attendant, who should also receive food. If more than one severely malnourished child is found in a family, make sure that all other young children of that family are fed.

a. Age

- **Under 5 years or, if age is unknown, height below 110 cm.**
- **In the case of malnourished infants below 6 months of age, the mother should be admitted to the targeted feeding programme together with the infant, because the nutritional status of young infants mainly depends on the nutritional status of the mother, and rehabilitation of the infant should take place through improved breast feeding.**
- **Malnourished older persons (children above 5 years, adults, elderly) may also be admitted depending on the situation and available resources.**

b. Nutritional status

- **Weight-for-Height < 70% of the median (or <-3 Z-Scores below the median reference value) = TFP**

70 - < 80% of the median (or - 3 to < - 2 Z-Scores below the median reference value) = SFP

- **Nutritional oedema: bilateral oedema on the lower legs and/or feet = TFP.**

- **If malnourished persons above 5 years of age are also admitted, nutritional status may be assessed clinically, since clear, unambiguous anthropometric criteria do not exist.**

Treatment in TFCs is usually divided into 2 phases. All newly admitted severely

malnourished children with associated pathology should start their treatment in a 24-hour intensive care unit (Phase I) according to the treatment schedule. Those without complications can usually start in day-care (Phase II).

Severely malnourished children usually die from complications. If the capacity of 24-hour intensive care units is limited, complications should be considered as a priority for admission. Suggested guidelines are listed below. However, use of clinical criteria requires more skilled staff.

Criteria for the selection of cases to be admitted to 24-hour intensive care units in TFCs

Less than 70% (or - 3 Z-Scores) weight-for-height in combination with one or more of the following complications:

- marasmic kwashiorkor**
- severe dehydration**
- persistent diarrhoea and/or vomiting**
- extreme pallor, hypothermia, or <<shock>>**
- signs of systemic, lower respiratory tract or other localized infection**
- severe anaemia**
- jaundice**
- persistent loss of appetite**
- severe lethargy**
- age less than 12 months**
- young children are particularly at risk from the adverse effects of malnutrition.**

Children aged 5 years or more who are clinically assessed as suffering from malnutrition are usually admitted to SFPs, unless they also show signs of the more serious associated pathologies.

Criteria for transfer from 24-hour intensive care units (Phase I) to the day-care programme (Phase II) are given in Chapter 4, Part III.

Discharge Criteria

During food crises, it is important to keep a logical coherence in entry and exit criteria between SFPs and TFPs. This is necessary in order to define which children will receive which level of treatment and to set firm conditions for referral.

It is usual to discharge a child from the TFP to the SFP after he has reached $> 80\%$ W/H (or > -2 Z-Scores) over 2 consecutive weighings. If there is no SFP, children should only be discharged once they have reached $> 85\%$ W/H (or > -1.5 Z-Scores) over 2 consecutive weeks. The most important criteria, however, is that the child shows a clearly ascending growth curve and is in a good general condition when he leaves the programme.

Discharge criteria from targeted SFPs are based on a W/H which is not associated with an unacceptable risk of morbidity or death under conditions prevailing in the community. The discharge criterium is usually $2 \times 85\%$ W/H (or 2×-1.5 Z-Score) during two - four consecutive weeks. If resources are limited, it may be decided to discharge children as soon as they reach 85% W/H.

In situations where general food rations are grossly inadequate (<1500

Kcal/person/day) and/or malnutrition prevalence is 2 20%, it is preferable not to discharge children from a SFP (blanket or targeted), until general food availability has improved. Centres should be organized so as to give maximum attention to the moderately malnourished children.

An example of a logical structure for criteria allowing integration of selective feeding programmes is given below:

Figure 13. *Criteria for entry and exit from supplementary and therapeutic feeding programmes*

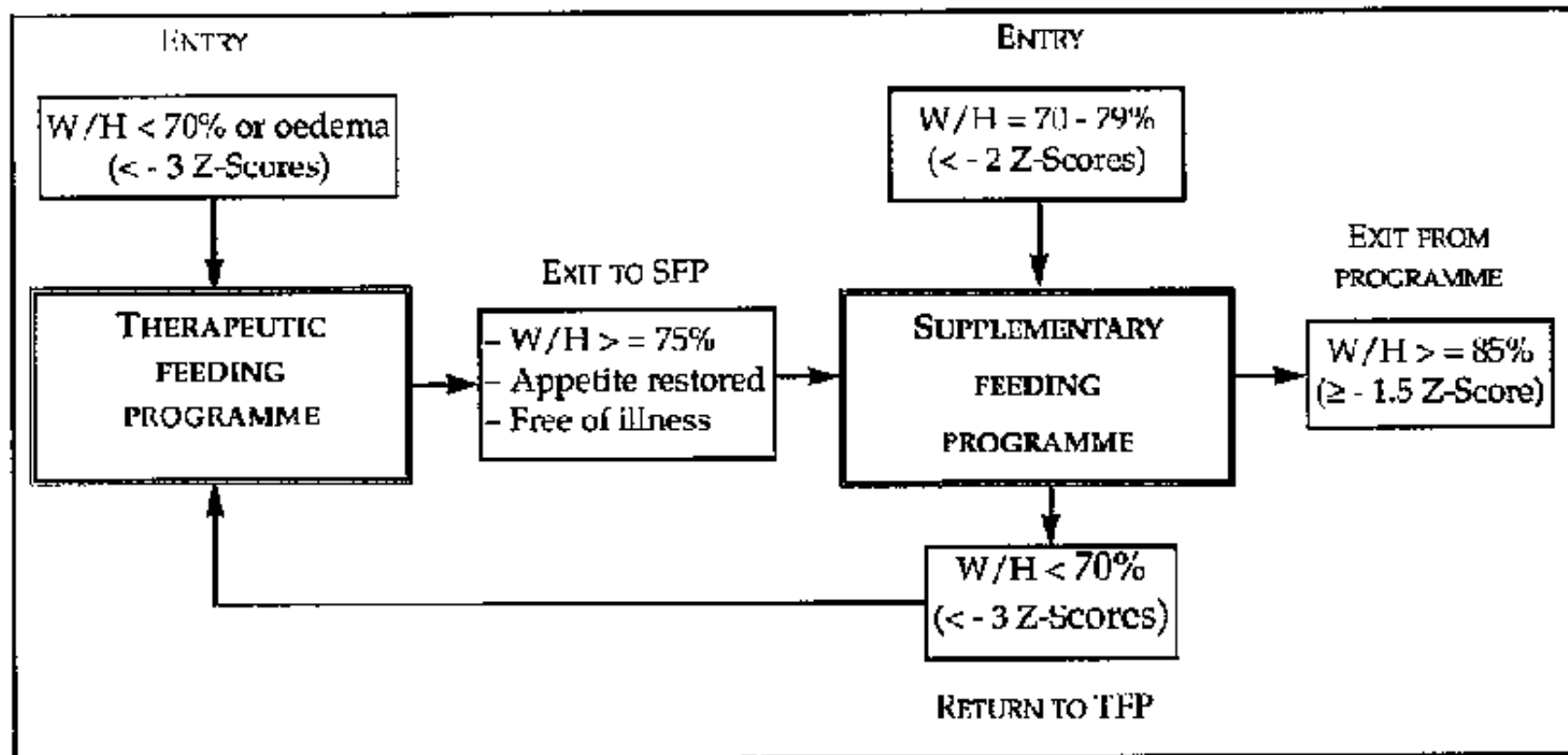

FIGURE

Figure 13. Criteria for entry and exit from supplementary and therapeutic feeding programmes

Targeted feeding programmes prioritize malnourished children under 5, because of their greater vulnerability and because of their increased risk of dying. Nevertheless malnourished children exceeding this age limit or adolescents/adults may also be admitted as individual cases.

Only when the numbers of adolescents/adults needing treatment becomes of public health significance is it necessary to consider their treatment in a separate unit (see Annex 3).

If there is significant malnutrition in other age groups, this must to be taken into account in planning.

3. Screening and selection

Once a nutrition survey (using weight-for-height) has justified the opening of targeted feeding programmes, the quickest way to identify all eligible children is by means of a population screening of mid-upper arm circumference (MUAC):

1. Execute a MUAC screening of all children between 6 months and 5 years (or height < 110 cm) in the population (Instructions in Annex 2.).

2. All children whose MUAC is < 13.5 cm and/or oedema will be selected to have their weight and height measured.

3. Children whose W/H is 70% - 79% (< - 2 Z-Scores) will be selected for supplementary feeding.

4. Children with W/H < 70% (< - 3 Z-Scores) and/or oedema, and/or those with MUAC < 110 mm will be selected for therapeutic feeding.

MUAC is a suitable tool for initial screening but admission to the feeding programmes should be based on W/H (see Fig. 14). However, because presence of bilateral oedema or a MUAC < 110 mm indicate an increased risk of death and acute malnutrition, these attributes also justify admission to a TFP, regardless of W/H.

- In a settled population, all households should be informed to bring their children below 5 years to the feeding centre for screening,**
- or house mass screening can be organized,**
- or regular screening can be performed through household visits of community health workers,**
- or new arrivals in a refugee camp should be screened during their registration.**

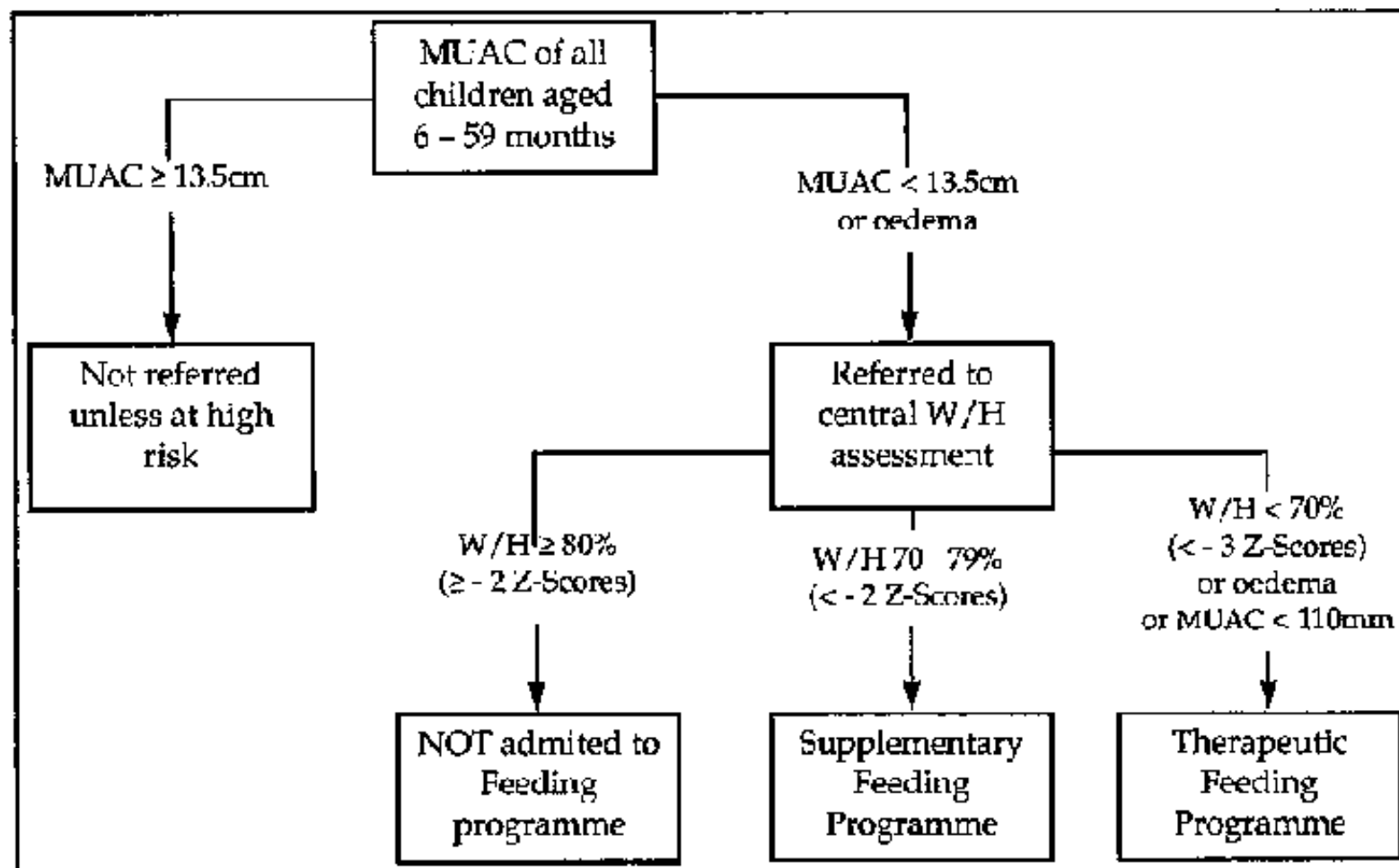
Figure 14 : Rapid screening method for feeding programmes**FIGURE**

4. Treatment in a therapeutic feeding centre

First phase

Treatment of severe PEM involves intensive medical and nutritional treatment.

Care must be taken to choose suitable sites for the shelter of the participants (both and their carers), which need to be accessible to the population and near a health facility. Treatment of severe PEM is divided into two phases:

- In the 24-hour care unit medical treatment, including rehydration, is started to control infection and reduce risk of mortality. At the same time the careful introduction of a sustenance level diet will prevent nutritional deterioration and allow normalization of disturbed metabolic functions and to prepare them to manage the large amounts of food given later during the rehabilitation phase.**

Children admitted without medical complications can be admitted directly to the second phase if resources are limited.

Treatment Phases of Severe Malnutrition

CARE	ACTIONS	COMMENTS
FIRST PHASE: 24-Hour Care	1 - 7 Days*	
- Rehydration	Special Formulation	All children day 1, then as required
- Start Medical Treatment	Systematic + Prescribed	To standard protocol
Initiation Nutritional Treatment	8 - 10 feeds/day 100Kcals/kg/day	Gradual Vol. Increase
SECOND PHASE: Day-Care	~ 14 days*	
- Continuation Medical Treatment	Systematic + Prescribed	To Standard Protocols
- Nutritional Rehabilitation	4 - 6 feeds/day to > 200Kcals/kg/day	Gradual Vol. Increase
- Transition to Social Environment	Vary diet, psychosocial stimulation	Local foods, singing and playing

FIGURE**Medical Treatment**

Treatment and surveillance is focused on the main causes of death and towards correcting metabolic imbalances and vitamin deficiencies.

Main Causes of Death in Severe PEM.

- **Dehydration**
- **Infection**

- **Hypothermia**
- **Hypoglycaemia**
- **Cardiac failure**
- **Severe anaemia**

DEHYDRATION

Severe malnutrition is almost always accompanied by diarrhoea, resulting in severe dehydration and malabsorption. Dehydration is the most important cause of death in severely malnourished children. The diagnosis of dehydration in children with PEM is difficult, especially for those with kwashiorkor.

Signs of severe dehydration in children with PEM

- **Child limp, apathetic or unconscious**
- **Rapid weak pulse**
- **Skin pale and cold, with decreased turgor**
- **Sunken eyes and fontanelle**
- **Dry mouth**
- **Absence of tears when crying**
- **Urine volume decreased**

Give oral rehydration whenever possible and if necessary by a navel-gastric tube. Intravenous fluids are not recommended for use in treating severely malnourished children because there is serious danger of overloading the circulatory system, leading to pulmonary oedema and death. It is only in cases of very severe shock that one can give Ringer's lactate (Hartmann solution) or isotonic saline

(10ml/kg/hr for the first 2 hours), with extreme caution. The respiratory rate should be monitored every 30 minutes, because faster breathing is the earliest sign of cardiac overload (see Ref. 7).

Malnourished children tend to have an electrolyte imbalance with a major excess of sodium. Oral rehydration solutions should be reduced in sodium content in order to prevent sudden death from cardiac failure. Therefore, severely malnourished children need a different ORS formula than the one generally used (WHO ORS) for well-fed and moderately malnourished children.

The classical WHO ORS should be diluted to half-strength (i.e. 1 sachet diluted in 2 litres rather than 1 litre), and sugar (25g/litre) and potassium (2g/litre) added. Due to the potential danger of potassium overloading, potassium supplementation requires strict supervision.

Children with severe PEM are deficient in both potassium and magnesium, as well as other minerals (zinc, copper, selenium, iodine). A well balanced mix of different minerals is therefore necessary to restore deficiencies and electrolyte imbalances. Pre-formed sachets of a special ORS are now available for the treatment of severely malnourished and dehydrated children (see Annex 15).

INFECTION

Almost all severely malnourished children are suffering from infection (Ref. 19). The most frequent problems are:

- Respiratory tract infections**
- Urinary tract infections**

- **Measles**
- **Gastrointestinal infections**
- **Malaria**
- **Skin infections**
- **Septicaemia**

Respiratory, urinary and other infections are not easy to diagnose in severely malnourished children because the classical signs of infections (fever, pain, inflammation etc.) can be masked. Due to malnutrition, the immune systems are inhibited and the child does not have the normal defense mechanisms. A severely malnourished child can develop septicaemia without fever.

It is crucial to examine each child carefully on admission, and to keep examining them each day during the first phase of treatment. In the majority of cases, antibiotic treatment will be required (see Ref. 7 and 8).

The severe complications with measles for malnourished children leads to a very high case fatality rate (30%). Common complications with measles: bronchopneumonia, diarrhoea, stomatitis, otitis, laryngitis, vitamin A deficiency. As measles is so contagious, admission procedures should include systematic measles immunization for those who were not previously immunised. Severe malnutrition is NOT a contra-indication for measles immunization.

Malaria prophylaxis is not routinely given. However, in malaria endemic areas, during peak season, routine treatment for malaria for all children may be given. The choice of treatment will depend on the local pattern of drug resistance and national policy (see Ref. 7 and 8).

Persistent diarrhoea, which frequently accompanies severe malnutrition, is caused by atrophy of the intestinal mucosa and can only be treated by intensive nutritional rehabilitation itself.

HYPOTHERMIA

Hypothermia is a frequent cause of death, especially early in the morning. Severely malnourished children cannot regulate their body temperatures adequately and they <<cool>> very quickly when there is a drop in external temperature. Even in tropical climates, temperatures at night can fall very low in an open ward. Body temperature should be measured once or twice daily and the child should be kept warm: let the mother keep the child close and provide adequate supplies of blankets. Never wash a hypothermic child, not even with warm water.

HYPOGLYCAEMIA

Death by hypoglycaemia occurs frequently and most often at night. For this reason it is essential that there is regular feeding during day and night (at least 1 - 2 meals).

CARDIAC FAILURE

Cardiac failure can result from electrolyte disturbances, overload of fluids or severe anaemia.

The first two causes should not occur when a proper oral rehydration and nutritional rehabilitation scheme is followed. For the treatment of severe decompensated anaemia, see below.

SEVERE ANAEMIA

Malnourished children seem to tolerate anaemia remarkably well. Blood transfusions should not be given, because of the danger of over-loading the heart and transmission of HIV and other infections. Transfusion is only required in exceptional cases, when the child presents with symptoms of decompensation (see Ref. 7 and 16).

Folic acid (5 mg/day) should be given from the day of admission. Iron, however, should NOT be given during the first two weeks after admission. Iron repletion has an adverse effect on the course of some infections (by promoting bacterial growth and free radical formation). Iron overload carries a serious risk of death, especially in young children.

INTESTINAL PARASITES

Mebendazole should be given routinely, since most severely malnourished children suffer from worms. Do not give mebendazole to children younger than 12 months.

VITAMIN DEFICIENCIES

· Vitamin A:

Vitamin A deficiency is clearly associated with increased mortality. PEM is usually associated with low vitamin A body stores and often with frank vitamin A deficiency. Furthermore, vitamin A requirements are greatly increased during nutritional rehabilitation.

An oral therapeutic dose should be given (see Ref. 8). Children younger than 6 months should not be given vitamin A because of possible toxicity; supplements should also be given to mothers within 1 month of delivery and for those breastfeeding.

Be aware of possible excess (toxic) doses given to children who recently received a mass-dose of vitamin A: re-admissions, children referred from a SFP or children admitted shortly after a mass measles immunization campaign where vitamin A was distributed (see Ref. 17).

· Vitamin C:

In areas where the diet is limited in Vitamin C, or wherever cases of scurvy are reported, a curative dose of Vitamin C should be given on admission to each child followed by regular prophylaxis (see Ref. 7).

· Other Vitamin and micronutrient deficiencies:

Other vitamin and micronutrient deficiencies are common in some areas:

- Vitamin B1 (beriberi)**
- Vitamin B6/PP (pellagra)**
- Vitamin D (rickets)**
- Iodine (goitre and cretinism)**

If you face these kinds of deficiencies in the feeding centre they should be treated in accordance with MSF Clinical Guidelines (Ref. 7). In addition, a real control strategy should be formulated: active surveillance, treatment of cases, prevention

through supplementation with tablets or food fortification and advocacy.

The specific pattern of medication for a child entering the TFC will depend on the locally defined essential drugs and any other medication prescribed after clinical examination.

Initiation of Nutritional Therapy

It takes time for the metabolic mechanisms of a severely malnourished child to readjust to food intake. Therefore, do not give too much protein and energy too early: because of its osmotic value, absorbed food increases body water, and therefore can cause cardiac failure and sudden death.

Feeds must be given in small amounts and frequently. Children should never be force fed: use the child's appetite as a guide.

FEEDING: COMPOSITION AND FREQUENCY

To allow readjustment of metabolic mechanisms, the child should stay in Phase I for a maximum of one week on a diet providing just enough energy and protein for maintenance: 100 kcal/kg/day and not more than 3g protein/kg/day.

During Phase I, food requirements have to be calculated individually, according to bodyweight and required meal frequency, and marked on the child's individual patient card. However, a ration providing 100 kcal/kg/day is not enough to allow weight gain and therefore should not be given for more than one week.

For practical purposes, use high energy milk (HEM) formula with an energy

density of 1 kcal/ml. Aim to give 100 ml HEM/kg bodyweight/day; this is equivalent to providing 100 kcal and 2.9g protein/kg/day.

The total amount of 100 ml/kg/day should be provided through a high number of small feeds. An ideal distribution is:

- **day 1 - 2: 12 feeds of 8 ml/kg (every 2 hours)**
- **day 3 - 7: 8 feeds of 12 - 15 ml/kg (every 3 hours)**

If these frequencies are not possible, an absolute minimum is 6 feeds/day, of which at least 1 must be during the night.

Psychological stimulation of the child by its mother and by personnel is crucial in getting the child to eat again.

High Energy Milk (HEM) for therapeutic feeding

	grams per litre	protein (g)	kcal
Dried Skim Milk	80	28.8	285
Vegetable oil	60	—	530
Sugar	50	—	200
Total (*)	1 litre	28.8	1,015

** Water is added to the ingredients to make a total volume of 1 litre (about 500ml water).*

FIGURE

Guidelines for preparation of HEM are given in Annex 16.

NASO-GASTRIC FEEDING

Indications for naso-gastric feeding are:

- Complete anorexia**
- Severe dehydration**
- Child cannot drink (too weak)**
- Repeated vomiting**

Try to breastfeed or feed by spoon each time before resorting to feeding through the tube. If possible, try not to tube-feed for more than 3-4 days. The tube should be changed every 24 - 48 hours by trained health staff.

It is vital to take time to explain the necessity of tube feeding to the mother so that she accepts the feeding and does not take the child away.

MINERALS

A limitation of the HEM formula is that it does not contain sufficient potassium and other minerals which the malnourished child is depleted of. HEM should be supplemented with a sachet of the <<Mineral Mix>> (in development) (see Annex 15).

Until these mineral sachets are available, only potassium should be added to the

HEM (2g KCL per 1000 ml HEM). The addition of potassium should be strictly controlled, because of the possible danger of potassium overloading. If fortification cannot be controlled, bananas should be added to the diet as a source of potassium.

FEEDING OF CHILDREN WITH DIARRHOEA

The idea that <<resting the gut>> is the best treatment for diarrhoea is not true. Milk in small frequent feeds stimulates the re-generation of the gut epithelium.

True lactose intolerance is rare, and only a small minority of children with true lactase deficiency will need to be given a lactose-free formula (K-Mix-II or fermented milk products).

DISCHARGE TO THE NEXT PHASE

Until medical complications (dehydration, systemic infections, risk of hypothermia or hypoglycaemia) are under control, the child will stay in the 24-hour intensive care unit for treatment and observation.

Once the medical complications are under control (which may even be within one day), the child can be transferred from the intensive care unit to day-care.

The indications for moving to the Second Phase of the TFP are recovery of appetite and a change of attitude/expression (i.e. the child loses his lethargy and becomes interested in the environment and may start to smile). (There does not have to be loss of oedema before movement to the Phase II).

Children should never stay in the First Phase for more than 7 days, since the 100 kcal/kg/day ration does not allow weight gain.

Second Phase

Once the child's appetite is recovering and medical complications are brought under control, he can be moved from the first to the second phase of treatment, which is a day-care treatment. Children arrive in the feeding centre early in the morning and return home in the late afternoon.

Nutritional Rehabilitations

QUANTITY

Children, when entering the second phase, have had acute infections treated and metabolic and electrolyte imbalances brought under control. They are now able to tolerate larger quantities of food and begin nutritional rehabilitation.

Whereas food intake is limited in the first phase (the objective being to restore metabolic functioning and control infections), the objective of treatment in the second phase is to restore normal weight-for-height as quickly as possible. Consequently, medical treatment is continued and larger quantities of food are provided to promote nutritional rehabilitation.

These children, if properly treated, can gain weight very quickly (up to about 20g/kg/day) which is 20 times the normal rate of weight gain at the age of one year. Almost all energy consumed above maintenance level (+ 90 kcal/kg/day) is used for building new body tissue (i.e. weight gain).

To achieve maximum weight gain, the recovery diet should provide a minimum of 200 kcal and 5g protein/kg bodyweight/day (= 10% protein calories). The increase in food intake should be smooth and progressive. Never force children to eat, children should be fed on demand and may consume up to 300 kcal/kg/day. Practically speaking, it may be impossible to calculate individual requirements based on body weight for each child, therefore one often distributes a standard large ration (i.e. 350 ml) for each meal to all children. Older/larger children, or those with a very good appetite, will need more than 350 ml per feed: therefore, always make a round for those who may want a second serving.

An important limitation to the amount eaten, is the capacity of the stomach, which puts an upper limit to the size of the feeds. Stomach volume has been estimated to be 3% of the total body weight. Thus, in a child weighing 6kg, the stomach capacity is approximately 180 ml. Therefore, the smaller the child, and the more malnourished, the smaller and more frequent the feeds should be.

COMPOSITION OF FEEDS

The aim is to devise a mixture, which, if fed in amounts which the children can take, will provide at least 200 kcal and 5g protein/kg bodyweight/day.

High energy milk (HEM) has suitable nutritional properties, providing 100 kcal and 2.9g protein per 100 ml.

HEM feeds can be alternated with porridge feeds, which are based on a blended food (e.g. CSM, WSB). A porridge should provide 100 - 150 kcal and 3 - 4g protein per

100 ml (10-12% protein calories). In order to prepare a semi-liquid porridge with required energy and protein density, DSM and oil should be added, as well as sugar for taste (recipe given in Annex 10). High-energy and -protein biscuits are also sometimes used as an easy (take home) meal.

Good weight gains have also been achieved on diets composed of local foods: local staples (cereal plus pulse) with meat/fish, vegetables and oil. These local meals will then replace the porridge meals. Experience has shown that local meals are very much appreciated by the children. A mixed diet is particularly preferred for older children from the second week on. A limitation to local meals is the energy density, which should provide enough energy to allow rapid growth, but should also be (semi)-liquid. Therefore, oil may be added to local foods to improve the characteristics.

All children should be able to eat a family-type diet when they leave the feeding centre. Transition to a family diet and meal frequency are therefore important aspects of nutritional rehabilitation. As the child improves, the diet should be replaced by local foods and meal frequency should be changed to come into line with family meal times.

A good diet will be composed of alternate HEM and porridge/local meal feeds.

Example of meal schedule in day-care

Time	Meal
8.00	HEM + banana
10.00	HEM
12.00	Porridge
14.00	HEM
16.00	Porridge
17.00	Return home with package of biscuits

FIGURE**Medical Treatment, Minerals and Vitamins**

During the second phase, daily monitoring of the medical state is still necessary. Standard treatments and prophylaxis should continue to be given.

A supply of Iron is necessary to provide for an increase in red cell mass and may be given safely after the second week of treatment (ferrous sulphate 100 mg/day from day 15). Folic acid treatment (5 mg daily or the ferrous/folic complex) should be continued.

Other Vitamin supplements should preferably be supplied through a diet containing fresh vegetables and fruits, but may also be given by multivitamin tablets. If fresh vegetables and fruits cannot be given, supplementation with vitamin C tablets is necessary (125 mg per day).

In addition, if vitamin deficiencies are routinely found in new entrants, a real control strategy should be formulated: active surveillance, treatment of cases, prevention through supplementation with tablets or food fortification and advocacy.

Psychosocial Treatment

It is recommended to include psycho-social stimulation sessions in conjunction with the medical and nutritional therapy. Psychosocial stimulation improves the prognosis for recovery. While it may be difficult in emergencies, group play and singing/music/story sessions should be introduced and carers should be encouraged to play with and stimulate children.

Infant feeding in a TFP

It should be clear that breast feeding should be promoted and continued during the whole treatment course. If it is possible, breastfeeding should even be continued over the first critical phase when the child is ill and being fed by navel-gastric tube. Breast feeding has a proven protective role against dehydration during diarrhoea and facilitates rapid recovery of digestive and absorption capacities of the gut. Even in the early phases of treatment, breastmilk is absorbed well.

In infants, breast milk should be the main (and best) source of energy and protein during rehabilitation, only supplemented with HEM if necessary.

Breast milk production of the mother should therefore be stimulated by:

- **sufficient feeding and liquid intake by the mother, as well as sufficient rest,**
- **HEM-milk formula feeds should be given ad libitum after each session on the breast.**

Do not use artificial infant feeding formulas except for rare cases in which the mother is not able to breast feed (mother seriously ill or dead). Always try to look for a wet nurse. If the infant is given artificial milk, besides breastmilk, he is less motivated to suckle and therefore breastmilk production is decreased.

To inhibit the dangers of artificial feeding (diarrhoea, malnutrition), one has to strictly control the hygienic conditions and preparation (i.e. dilution) of the infant formula milk.

The young infant needs approximately 105 kcal and 2.8g protein/kg bodyweight/day. Energy content of the infant formula milk should be 70 kcal/100 ml milk. Therefore, the infant needs 150 ml/kg/day, divided over 5 - 6 meals given throughout the day.

An example for reconstituted and enriched milk formula for newborns (0 - 5 months) is given below.

Reconstituted milk for young infants (0-5 months)

	per litre	per 200ml
DSM	50g	10g
Sugar	75g	15g
Oil	25g	5g
Add boiled water to the mix until the volume equals 1 litre or 200ml		
Approximate nutritional value per 100ml		
Energy	70kcal	
Protein	1.8g	
Vitamin A	(see specifications on packing)	

FIGURE

- **Be sure that the DSM is vitamin A fortified.**
- **Reconstituted milk cannot be kept for more than 1 - 2 hours.**
- **Do not feed by bottle - bottles are forbidden in feeding centres. Feed children using a small spoon or syringe and teach the mother how to use a spoon.**

5. Treatment in supplementary feeding programmes**Types of SFPs**

Blanket and targeted supplementary feeding can take two forms:

1. Wet rations are prepared/cooked once or twice daily in the kitchen of a feeding centre and consumed "on - site". The child has to be brought to the

feeding centre every day by the mother.

2. Dry rations are distributed (usually weekly) to "take home" for preparation and consumption. Rations will be collected once a week.

WHEN TO DISTRIBUTE DRY OR WET RATIONS

In emergency situations, resources (staff, materials) are often limited, so the possibility of a dry feeding programme should always be considered first, or may even be the only feasible option.

There is no clear evidence to be found from the literature on which type of feeding programme is more effective in combatting malnutrition.

Some strengths of dry feeding are:

- When resources (staff, materials) are limited, dry feeding is easier to organize than a wet feeding programme (fewer staff needed per child served).**
- A dry feeding programme can serve more children than a wet feeding programme.**
- The risk of transmission of communicable diseases among highly vulnerable malnourished children in dry feeding programmes is far less than in wet feeding programmes.**
- The time cost to mothers for participating in the programme is much less in a dry feeding programme.**

- **Improved accessibility and capacity usually means that there is better coverage of malnourished children in a dry feeding programme than in a wet feeding programme.**
- **The improved access of dry feeding programmes is particularly important when dealing with a dispersed population.**
- **In famine situations where people are still living in their homes, dry feeding helps to prevent displacement.**
- **Dry distribution keeps responsibility for feeding the child with the mother.**

A wet feeding programme is justified in the following situations:

- **When there is no other source of food, dry rations will disappear into the family pot or be diverted to the <<stronger>> household members.**
- **Firewood supply is a major problem.**
- **People have no cooking utensils.**
- **Security reasons: when it is feared that the women carrying their dry ration will be robbed on their way home.**

Ration Size in SFPs

The ration provided in a SFP is meant as an addition, necessary to supplement the defective family diet, and to allow for catch - up growth. The supplement

consumed should be at least 500Kcal (and 15 grams of protein) per day.

Often the child will not consume all of the distributed food: the distributed food will be shared with other household members (dry), or the food will (partly) substitute a regular meal at home (wet). Therefore, in order to make sure that the child actually consumes the required amount of food, the rations distributed should be well above the target amount.

Wet feeding

In wet feeding part of the ration is sometimes consumed in the feeding centre by accompanying siblings, or the meal at the feeding centre may be considered by the family as a substitute for a family meal - therefore the child is given less at home.

Therefore, in wet feeding programmes, rations should provide a target amount of 500 - 700 Kcal and 15 - 25g of protein/day. The quantity of protein is high: 10 - 15% of the energy is provided by protein. This is because it is assumed that the family meal is poor in protein supply (see Annex 16).

A young child (< 12 months of age) is unable to consume much more than 250 ml (300 Kcal) in one meal, because of his limited stomach size. Therefore, wet supplements should be given by at least 2 meals daily, and at times that do not coincide with family meals.

Children should be allowed to eat as much as they want if food is available. Food should also be provided to carers, especially if they are siblings, as they are also likely to be at risk.

Dry ration distribution

In dry ration distribution programmes, part of the ration will very likely be shared with siblings or other family members, or the meal prepared from the ration at home may not be a supplement but will substitute a normal family meal.

In dry ration distributions the intended ration should therefore be doubled or tripled to provide 1000 - 1200 Kcal and 35 - 45g of protein/day, in order to compensate for sharing and substitution (see Annex 16).

Ration Composition

- A supplementary meal should provide a balanced, high concentration of energy and protein: at least 1 kcal/ml and 10 - 15% of the energy provided by proteins. In addition the supplement should provide a balanced mix of essential micronutrients (vitamins and minerals).

A ration should contain a cereal or a blended food as a base (table below), providing the main source of energy and protein. The resulting porridge must be diluted to be (semi -)liquid, to be palatable for young and/or malnourished children, and yet retain a high energy and protein density. Therefore, the energy and protein density of the porridge must be increased by adding a high - protein source and a high - energy source (oil) in balanced amounts. The additional commodities should also provide the essential vitamins and minerals that are lacking in the cereal base. Sugar is usually added to increase energy density, but mainly to improve the taste. (The nutritional value of different food commodities is given in Annex 5).

The actual composition of the ration will depend on the availability (from donors and local markets) and acceptability (local food habits) of the commodities.

Commodities commonly used in supplementary feeding programmes

A. Blended food (*) :	
- Corn-Soya-Blend (CSB)	- Wheat-Soya-Blend (WSB)
- Corn-Soya-Milk (CSM)	- Wheat Soya-Milk (WSM)
B. Locally Produced Mixes :	
1. Base : Cereal	
- Rice	
- Maize	
- Sorghum	
2. High-protein source :	
- Beans	- Groundnuts
- Lentils	- Soya beans
- Dried skim milk (DSM)	- Oil seeds
3. High-energy source :	
- Vegetable oil	- Oil seeds
- Butter oil	
- Groundnuts	- Sugar

FIGURE

(*) Blended foods may be available through WFP or directly from donors. They are nutritionally valuable (fortified with vitamins and minerals), easy to transport and store, and can be very useful to initiate a SFP when appropriate local foods are lacking.

Examples of recipes for wet feeding and dry rations are given in Annex 16.

Whole - grain commodities (cereals, beans) must be ground before utilisation. Beans and groundnuts can be roasted before grinding to reduce necessary cooking time (firewood is often scarce in emergency situations).

Sometimes special high - energy/high - protein biscuits will be available from donors. Although their nutritional value is considerable, be aware that they can be rather popular with other family members and raise a good price on the market. Therefore, if a dry ration is offered, do not include the biscuits in the calculation of the ration size. These special biscuits are particularly useful for the initiation of wet SFPs in situations where other commodities are not immediately available and cooking is difficult.

Dry ration foods can be distributed either as separate ingredients, or as a mixture (premix). There are two reasons NOT to distribute the supplementary ration ingredients separately:

- During preparation at home, some of the separate ingredients may not be added to the porridge for the child, but may be consumed or traded by other family members, (especially sugar, oil and milk powder). The remaining ingredients do not make up a nutritionally balanced porridge allowing for rapid catch - up growth.**
- Milk powder, given separately, may be diluted by the family with unboiled, contaminated water, which can be harmful. However, milk powder may be distributed in a premix, which also contains a cereal, as long as the milk powder is**

not the major component. The premix has to be boiled to be edible (because of the cereal), thereby minimising the risk of diarrhoea (see Annex 14).

A premix for dry ration distribution will include a cereal base, a high energy source and a high protein source. The premix can be stored at home for about 1 week if milk powder is included, otherwise premixes can usually be kept for 2 weeks. The porridge, once prepared, should not be kept for more than two hours. See Annex 14 for details about the premix preparation and expiry.

Wet meals should be timed so that they don't coincide with family meals, otherwise the meal at the centre will not supplement the child's family intake. Try to arrange meal times to fit in with the kitchen capacity (i.e. same meal times as TFPs with 2 shifts of children) and yet provide children with meals that suit the community meal and activity pattern.

Medical Care in Supplementary Feeding Programmes

Children can only recover effectively from malnutrition if proper care is taken of additional medical complications. Infections may often be an underlying cause of malnutrition. A feeding centre should be able to provide basic treatment on health post level or, if not, be attached to, or located near a health centre. A clinical investigation of all new admissions should be part of the standard procedures. Additionally, a nurse should make daily rounds in the feeding centre to identify sick children.

Mothers often have first contact with a health centre when their child is malnourished (often for another reason). Health centre staff should be able to

recognize acute malnutrition and refer the child to a nearby feeding centre.

INDIVIDUAL MEDICAL TREATMENT

- Proper treatment of infections is essential for effective nutritional rehabilitation. The possibility of treating infections with antibiotics in SFPs depends on the level of the staff, otherwise children should be referred to local health facilities for treatment. Malaria should also be treated within the programme if staffing allows and severe cases of malaria referred if necessary. (For treatment protocols, see Ref. 7.)**
- Children with diarrhoea and/or dehydration should be given oral rehydration therapy. Sometimes a special ORT - corner may be established in the feeding centre.(see Ref. 9)**
- Treat vitamin deficiencies (vitamin A, C, B's) in the centres according to MSF Clinical Guidelines (Ref. 7). In addition, if vitamin deficiencies are routinely found in new entrants, a real control strategy should be formulated: active surveillance, treatment of cases, prevention through supplementation with tablets or food fortification and advocacy.**
- For malnourished children suffering from anaemia, iron and folic acid should be prescribed as necessary (see Ref. 7).**

ROUTINE TREATMENT AND PROPHYLAXIS

Admission procedures should include a systematic check - up for measles immunization status (from immunization cards) and children should be immunized

if they have not been immunized or if their status is uncertain (if the child is > 9 months).

Most malnourished children have low body stores of vitamin A, so an oral prophylactic dose of 200,000 IU oil - based vitamin A should be given routinely on admission, and repeated doses given every three months. Children < 6 months should not be given vitamin A if they are being breast fed. When infants less than 6 months old are not being breast fed, a supplementation with 50,000 IU of Vitamin A should be considered before they reach 6 months. Supplements should be given to the mother (as long as she is not pregnant) (See Ref. 1.) Children < 8 kg should receive doses of 100,000 IU (3 drops from an opened capsule of 200,000 IU).

Be aware of possible excess (toxic) doses given to children who recently received a mass - dose of vitamin A: children discharged from therapeutic feeding, readmissions, or children admitted shortly after a mass immunization campaign where vitamin A was distributed, or in populations where a lot of red palm oil is consumed.

Mebendazole (not for children < 1 year) should be given routinely on admission. (see Ref. 8).

OPTIONAL ROUTINE TREATMENT AND PROPHYLAXIS

In malaria endemic areas, where there is no resistance to chloroquine, chloroquine prophylaxis may be given routinely according to the prevailing protocol for that area. If there is a high degree of chloroquine resistance, other

drugs may have to be used according to clinical guidelines or national protocols (See Ref. 7 for protocols).

If scurvy is a risk (high prevalence in the population or in the area), and no fresh foods are provided by the programme, vitamin C should be given routinely (125 mg per day or 500 mg/week).

In some circumstances, referral to a health centre may not be possible. In such cases a more extensive pharmacy will have to be kept in order to allow in - programme treatment - depending on level of staff and supervision.

Pregnant and lactating women

INCREASED NEEDS

Pregnant women have increased physiological needs and so are vulnerable to nutritional stress. Anaemia is the most important nutritional risk associated with pregnancy, but in emergency situations there is also a risk of PEM and vitamin and mineral deficiencies: iodine, vitamin A, B. C.

The possible consequences are:

- complications during pregnancy and delivery, associated with an increased maternal mortality risk,**
- prematurity and low - birth weight, associated with increased morbidity and mortality risk for the child,**
- low body stores of vitamins and minerals in the infant associated with a higher risk of nutritional deficiency diseases and impaired immunity in the child.**

Lactating women need extra energy, fluids and nutrients to support breast milk production, which is in the order of 0.5 - 1.5 litres per day.

Although many women feel uncertain about their breast milk quantity and quality in any community, under normal circumstances production will be sufficient. Even when the mother has an insufficient energy intake, her own body reserves will be used for the production of breast milk. Only after prolonged insufficient energy intake will the production of breast milk be reduced or even cease. Stress (refugee situations, war) is another important factor reducing the quantity of breast - milk. It is possible, however, to restore breast feeding, even if it has been stopped, through good nutritional support, stimulation and sufficient rest.

WHEN TO OPEN AND CLOSE A SFP FOR PREGNANT AND LACTATING WOMEN

In case the three following criteria are met, a supplementary feeding programme for pregnant and lactating women would be justified:

- General food supply to the population is inadequate: food availability is < 2,100K cal/person/day,**
- A nutrition survey indicates a malnutrition rate among children 6 - 59 months of age of 10% or more being <-2 Z-Scores (or < 80% of Median) Weight - for - Height, and/or having oedema,**
- If all the malnourished children are covered and there is sufficient capacity to include pregnant and lactating women as beneficiaries.**

A SFP for pregnant and lactating women can be closed when the general food

supply is sufficient.

ADMISSION OF PREGNANT AND LACTATING WOMEN

Selection criteria

All pregnant women in their third trimester should be included in the programme. Evidence suggests that nutritional supplementation will have a positive effect on the birth weight of the child only in the third trimester of pregnancy.

Lactating women up to 6 months after delivery (the period when the infant is entirely dependent on breast feeding) should also be eligible for the feeding programme.

The admission of pregnant and lactating women should be coordinated with antenatal services.

Size of the programme

The number of eligible women will rarely be known, but can be estimated indirectly, based on an estimation of the number of infants (< 12 months of age) in the population.

In a <<normal>> third - world population approximately 4.5% of the population will be younger than 12 months. Those infants, born during the past 12 months, have mothers who are, or have been eligible for the SFP for a period of 9 months (last trimester of pregnancy + first 6 months of lactation). Assuming no big changes in fertility/birth rates, the number of pregnant and lactating women

eligible for supplementary feeding can be estimated at 5% (allowing for miscarriages, etc.) x 9/12 = 3.75% of the population.

Example: In a refugee population of 20.000, 5% x 20,000 X 9/12 = 750 women are eligible for supplementary feeding.

Targeting

If the capacity of the programme is limited and cannot accommodate all 3rd trimester pregnant and lactating women, it may be necessary to target priority groups:

- 1. Lactating mothers of malnourished infants younger than six months.**
- 2. Lactating mothers with young infants whose breast - milk production has stopped, or is reduced.**
- 3. Pregnant and lactating mothers of malnourished children under 5 years.**
- 4. All lactating mothers up to six months after delivery.**
- 5. All pregnant mothers in the third trimester of pregnancy.**

SUPPLEMENTARY RATIONS

Ration Size

The extra energy requirement for normal healthy pregnant women is 350 Kcal/day in the third trimester of pregnancy, and 550 Kcal/day for lactating women in the first 6 months after delivery. The supplementary ration should cover these extra requirements, and allow for rehabilitation of nutritional status of mother and child as well.

The recommended energy supplement is approximately 1,000 Kcal/day. This recommendation covers both pregnant and lactating women for practical reasons.

Ration composition

The supplementary ration should be a high - energy and high - protein food. Protein should provide about 15% of the total energy to allow for compensation of a protein deficient family diet. Extra supplementation of micro - nutrients (iron, folic acid, vitamin A and C) should be included in the ration.

The type of feeding (dry take home rations or wet on - site meals), should follow the decisions made for feeding programmes for young children. Keep in mind that dry take home rations, meant to supplement the mothers diet, may be shared with other household members or sold.

It is not necessary to offer women the same foods used to supplement the diets of children; the women may not like baby - porridge. If possible, use local foods, including tasty ingredients (like onions, green vegetables) to make the meal more acceptable to the women. Be aware of special food habits and taboos of pregnant and lactating women in the local community.

MEDICAL CARE AND MICRO - NUTRIENT DEFICIENCIES

In coordination with antenatal services, pregnant women should be checked by a nurse, midwife or doctor on admission to the feeding programme.

Always check if pregnant women are completely immunized against tetanus. If the tetanus immunization status is national guidelines (see Ref. 7).

Take the opportunity to check the young children, who usually accompany their mother, for measles immunization and other EPI immunizations.

All pregnant and lactating women should receive an iron/folic supplement (prophylactic dose), in both wet and dry feeding programmes. Women showing clinical signs of anaemia should receive a therapeutic dose (see Ref. 8).

Be aware of compliance problems in dry feeding programmes. Women with signs of severe anaemia (see Ref. 7) should be referred to medical services.

In endemic areas, routine Malaria prophylaxis may be provided to pregnant women in accordance with national protocols (see Ref. 7).

Pregnant and lactating women are among the highest risk groups in populations where scurvy is prevalent. Most GFD rations contain little or no vitamin C and there may be very limited alternative sources. If scurvy is prevalent in the community, provide vitamin C to pregnant and lactating women: 500 mg/day during their attendance in the programme.

A pregnant woman with depleted or low body stores of vitamin A will deliver a baby with even lower vitamin A reserves, and the amount of vitamin A provided in breast milk will be reduced. These newborns are at high risk of vitamin A deficiency.

However, during pregnancy (especially the first trimester) large doses of vitamin A can have teratogenic effects, possibly leading to fetal malformations. Vitamin A supplementation of pregnant women should only be initiated if any of the following criteria are met (indicating a high risk of vitamin deficiency in the

population):

- **Frank xerophthalmia (including night blindness) is present in the population,**
 - **The population originates from a known or presumed vitamin A deficient area,**
 - **The population is subsisting on relief food supplies deficient in vitamin A.**
- uncertain or incomplete, re - immunize according to**

Pregnant women (without signs of vitamin A deficiency) are best supplemented through their diet or with small daily doses (< 10,000 IU). If this is not practically feasible, a large - dose (200,000 IU) supplement can be given immediately postpartum.

Pregnant women with clinical signs of Vitamin A deficiency should be referred to the local health facility.

Lactating women provide a major source of vitamin A for their infants through breast - feeding, but many women are themselves at high risk of deficiency. Consequently, lactating women should receive a large - dose supplement (200,000 IU) within 1 month of delivery.

It may be necessary to give specific prophylaxis for deficiency diseases in endemic areas or in specific circumstances (vitamin B. iodine).

6. Implementation and management of a feeding centre

Calculating the number of beneficiaries (See Chapter 3, Part III on Screening)

If exact numbers of malnourished children in a population are not known on

nutrition survey (see Chapter 4, Part I and II).

Based on a nutrition survey, the target population of the different feeding programmes can be estimated:

- Total population under five = Total population x 20%**
- Total population under five x Prevalence of severe acute malnutrition = Total number of severely malnourished children eligible for the TFP**
- Total population under - five x Prevalence of moderate acute malnutrition = Total number of children eligible for the targeted SFP.**
- Numbers eligible for blanket SFPs depend on which vulnerable groups are being targeted.**

Calculating the number of facilities

In order for wet feeding centres to be run efficiently (cooking, feeding, medical and nutritional supervision of the children), feeding centres should not be too big (TFP: maximum 60 - 100 children; SFP: 250 children). The maximum capacity will depend on staff levels and skills and the number of children in intensive care. Above these numbers the programme loses efficiency. With larger numbers of children it is better to increase the number of centres. Moreover, increased numbers of centres allows better geographic accessibility and therefore improved coverage of severely malnourished children.

From this number, the programme needs can be calculated:

- No. of feeding centres: TFP = 1 for every 60 - 100 malnourished children
Wet SFP = 1 for every 250 malnourished children
Dry SFP = 150/200 beneficiaries per day of distribution (750 - 1000 children/week)
- Food needs: daily rations x number of children

- Personnel

- Materials & equipment

Example:

Food availability is very low and is expected to get worse over the next few months.

A nutrition survey has shown high rates of severe and moderate acute malnutrition. Therefore, it is decided to implement a TFP, a targeted wet SFP for malnourished under 5 years and a blanket dry SFP for all children under 5 and pregnant and lactating women.

Total camp population	50,000
Population under - five (20%)	10,000
Population of Preg. + Lact. women (5%)	2,500
Prevalence of severe acute malnutrition (<-3 Z-Scores W/H and/or oedema)	3 ± 1,5%
Number of severely malnourished children (for TFP)	10 000 x 3% = 300

Number of severely malnourished children (for TFP)

10,000 x 3% = 300

Prevalence of moderate acute malnutrition (- 3Z -- < - 2Z W/H)

15%

Number of moderately malnourished children (for targeted SFP)

10,000 x 15% = 1,500

Number eligible for blanket SFP

12,500

300 children are eligible for the TFP

3 - 5 centres

1,500 children are eligible for targeted SFP

6 wet centres

12,500 people are eligible for the blanket SFP

15 - 20 distribution centres

The actual number of children attending the programme will depend on the accessibility.

Inform the population

Inform the population on the objectives of the programme by organizing meetings with community representatives and during mass screening sessions in the population. A good network of CHWs can also help promote community cooperation.

Construction and location

LOCATION

Feeding centres should be located near a health centre or hospital structure if possible. If there is need for more than 1 feeding centre, their location should be planned to improve accessibility of the programme to the population. Therapeutic and supplementary wet feeding centres need to be within 30 - 45 minutes walk of

all the population to be served; dry ration distribution centres should be within a 2 hour walk of all the population to be served.

When several centres for dry feeding are established, it is necessary to choose distribution days carefully and properly identify eligible recipients to avoid double registration.

CONSTRUCTION

· Wet feeding programmes require tents or shelters made out of local materials and plastic sheeting. Buildings should be adapted to climate and the number of people expected to stay during the days and nights. (In refugee populations, the site

should allow for a sudden influx of new refugees). Big tents suffice in emergency situations (25 m² for 12 persons). The whole area has to be fenced off and properly drained (see Annex 17 for lay - out plan).

- A special area for 'intensive care' should be organised in TFPs, where up to twenty children can stay during the early days and nights of their treatment (special areas may also be organized in wet SFPs for treatment of diarrhoea).

- Pharmacy, consultation room.**
- Store - room for food commodities.**
- Kitchen.**
- Dry distribution centres need to ensure a logical flow of people so all registration and monitoring data is collected and food distributed in an efficient way,**

maximizing patient flow and minimizing food loss (see Annex 17).

WATER AND SANITATION

- **Water sources should be protected and chlorinated.**
- **For wet feeding programmes, a supply of 30 litres of safe water/child/day is recommended, with an absolute minimum of 10 litres/child/day (cleaning centre, cleaning pots and pans, washing hands and children, preparing food, drinking water).**
- **For dry programmes 0.5 litre/person/day is required for hand washing and drinking - if water sources are not available make sure water is transported to the distribution site.**
- **A washing area within the wet feeding compound is necessary.**
- **Latrines can be built at thirty metres distance from the water supply, one for every 50 persons in a wet feeding programme (patients and carers). Bed - pots may be provided in the feeding centre for the smaller children. (Toilet facilities may also be necessary in dry feeding programmes).**

Materials and Equipment

FEEDING AND REGISTRATION MATERIALS (See the content of the kits - Annex 22)

If the necessary cooking utensils are not available locally or if the time is limited,

pecially formulated nutrition kits are available from MSF or OXFAM.

OTHER MATERIAL

- **Beds/mats, blankets, bed - nets,**
- **bed pots,**
- **lamps, torches,**
- **waste buckets, etc.,**
- **fuel (average quantity: 1 m³ firewood to boil 1000 litres water), - precision weighing scale for KCl (or standard weighing cups).**

Staff

Clear job - descriptions, responsibilities and working guidelines for both medical and non - medical personnel are crucial. If job - descriptions and tasks are not clear to the personnel, problems will inevitably arise.

Proper training of both medical and non - medical personnel is essential, before starting the programme. It is better to delay the opening of the centre for some days, until personnel are properly prepared. Continuous on - the - job training and regular formal training sessions for upgrading skills is necessary (see Ref. 11). It is essential to have a good supervision system. This will ensure that, on one hand, trained personnel will keep an adequate level of performance and, on the other hand, it will allow the identification of training needs.

When planning for personnel requirements, do not forget to schedule rest days.

Pharmacy (basic drugs)

Pharmacy requirements are for TFPs:

- **Ringer's lactate or Hartmann solution**
- **ORS (sachet per 1000 ml)***
- **Antibiotics (ampicillin, cotrimoxazole) (see Essential Drugs Guidelines, Ref. 8)**
- **Mebendazole (100 mg tab)***
- **Metronidazole (250 mg tab)**
- **Chloroquine (100 mg tab or 150 mg tab, depending on the national protocol)***
- **Vitamin A (200,000 IU cap)***
- **Ferrous sulphate (200 mg tab) + folic acid (0,25 mg)***
- **Folic acid (5 mg tab)***
- **Mineral and vitamin <<cocktails>>**
- **Potassium chloride (powder) (If no mineral mix available.)**
- **Vitamin C, B. and multivitamins***
- **Measles immunization materials: vaccines, cold chain (fridge in hospital and coolboxes)***
- **Aspirin* (300 mg or 500 mg)**
- **Paracetamol* (100 mg)**
- **Nystatin (250,000 IU)**
- **Quinine (200 or 300 mg, depending on the national protocol)**
- **Benzyl Benzoate* (25%)**
- **Tetracycline eye ointment* (1%)**
- **Chlorexydine / Cetrimide***
- **Zinc Oxide cream**

*** may also be required for SFPs**

Follow-up of defaulters

Through careful registration in the attendance register, and a clear definition of a defaulter (absence during two consecutive days), defaulters can be detected immediately. Home - visits by the nutrition outreach workers should be scheduled to follow up defaulters.

- Do not reprimand mothers: try to find out the reason for drop - out; they may have very good reasons (work, other sick family members). Or mothers may not attend because their children fall sick in which case it is essential to convince the mother of the importance to come to the feeding centre with the child. Sometimes a solution can be found with the help of the community.**
- A frequent reason for drop - out is because mothers do not feel comfortable in the feeding centre and lose motivation to attend. Proper accommodation (i.e. shelter from the sun and rain, clean latrines with adequate privacy and adequate food and water), a friendly atmosphere and continuous explanation to the mother on the course of treatment are essential in preventing drop - outs.**
- Another reason for drop - out from the programme may be that the mothers do not like the food offered to them in the centre (HEM, porridge). The provision of food, cooking materials and fuel to mothers to prepare their own meals might make daily attendance to the programme more attractive. Moreover, provision of foods can provide an opportunity for nutrition education.**
- If the reason for drop - out is the death of the child, it is important to include that child in mortality surveillance figures.**

7. Registration and monitoring

Registration

Proper registration should allow close monitoring and management of individual case progress (changes in nutritional and health status, treatment phase and diet, etc.), but should also easily provide information necessary to monitor the functioning of the programme at feeding centre level.

Examples of a registration book and an individual patient chart are given in Annexes 18, 19. Children are weighed and examined daily in TFPs and all this information should be recorded over time. Children are not weighed and measured every day in SFPs, but they do need to attend daily for food distribution (wet SFP) - therefore 2 registration books may be required for attendance and individual monitoring of health status.

ATTENDANCE REGISTER BOOK

Based on the register book, the statistics for overall attendance, admission, discharge and average child performance can be followed. A good registration system can rapidly detect defaulters, who can then be followed up by a home visit. Registration includes:

Identification: Bracelet number, name, age, sex, name of parents, address/section of camp.

Health indicators:

Admission weight, height, W/H%, clinical signs of malnutrition (oedema, vitamin deficiencies, etc.), other medical remarks.

Attendance indicators: Admission, present, absent, defaulter, discharged, death, transfer.

Definitions:

- **Admission: all new entries, including children who relapse after being successfully discharged from the programme. It does not include defaulters who were only absent for some days.**
- Present: TFP - physical presence for at least four meals during the day.
SFP - physical attendance for at least one meal during the day.
Dry SFP - physical presence for ration distribution
- WET - absent for 2 consecutive days; on the third day of absence the defaulter
Defaulter: will be visited at home by the outreach worker.
DRY - absent for 2 consecutive distributions, after the second distribution the child will be followed up.
Defaulters readmitted in the month are not included in end of month defaulter statistics.
- Death: any child who died while participating in the programme. It is important to follow up defaulters to see if the reason for not attending is death and include them in the mortality statistics.
- TFP - to hospital, or intensive care feeding centre.

Transfer: SFP - to hospital or TFP Blanket SFP - to hospital, targetted SFP or TFP.

Targetted:

- any child who was discharged from the programme after having reached the Discharge: official discharge criteria (may have been discharged to another programme i.e. TFP-> SFP).

INDIVIDUAL PATIENT CHART - TFP

The patient chart (Annex 19) gives a clear overview of the changes in nutritional status of each child (weight, height, and clinical signs: oedema, vitamin deficiencies etc.), health status (medical consultations, treatments, immunization), as well as the treatment phase and calculated food requirements.

Weights should be graphed on the chart, enabling regular monitoring of weight gain or loss. Weight gain together with the registered clinical observations (both positive and negative) enables prompt action in case of failure to respond to treatment. The chart also makes it easier to decide when to discharge the child.

INDIVIDUAL PATIENT CHART - SFP

In an SFP, the monitoring data can all be entered in a registration book as there is far less information that needs recording (Annex 18). Individual cards may be used (Annex 19)

Nutritional status monitoring:

- Weight assessment: every 1 - 2 weeks

- **Height assessment: every 4 weeks**
- **W/H% calculation: every 1 - 2 weeks**

Remarks: medical treatments, prophylaxis, special circumstances.

· Informations recorded on the individual card:

- **Identification:**
- **Bracelet number, name, address, admission date.**
- **Health indicators:**

Age, sex, weight, height, target weight, Weight - for - Height category, oedema, medical diagnosis & treatment.

- Food distribution:

Date, quantity.

Main Child Surveillance Procedures

There are 3 main procedures:

Correct application of admission and discharge criteria

The different treatment phases and transition criteria

Surveillance of the individual child

For a TFP the surveillance of each individual child is particularly crucial and should include:

*** During the First phase, close medical and nutritional surveillance of the child should be daily. Surveillance should consist of:**

- **daily weight measurement,**
- **growth curve,**
- **oedema assessment,**
- **clinical examination,**
- **temperature,**
- **treatment scheme (medical and nutritional).**

Food needs and meal frequency have to be calculated individually and marked on the child's individual chart.

*** During the Second phase, nutritional and medical surveillance is given every 2 days. A nurse should make daily rounds to identify any children that may be ill. Surveillance should consist of:**

- **weight measurement every 2 days,**
- **growth curve,**
- **monthly height measurement,**
- **oedema assessment,**
- **clinical examination,**
- **treatment scheme (medical and nutritional).**

Food needs (minimum requirements) should also be calculated and registered individually, although feeding is ad libitum.

Depending on the child's age and degree of malnutrition, a severely malnourished

child should gain 10 - 20g/kg/day during the Second Phase. At this growth rate the discharge criterium of 85% W/H should be achieved after about 1 month. A moderately malnourished child should gain 5 - 10g/kg/day. At this growth rate 85% W/H should be achieved within 4 - 6 weeks, and discharge after 6 - 10 weeks.

Failure of children to gain weight may be attributed to:

- irregular attendance to the feeding programme,**
- poor organization and supervision of the feeding programme, leading to inadequate supplementary rations, or incorrect recipes,**
- unequal distribution of food within the family (substitution or sharing),**
- specific nutrient deficiency,**
- acute infection,**
- undiagnosed psychological problem,**
- TB or AIDS.**

Any child who fails to gain weight should be investigated for all possible causes.

- If the child has not gained weight for 3 or more weeks, while receiving correct medical and nutritional care (including 2 full courses of antibiotics),**
- If all other causes of failure to gain weight have been excluded, AIDS or TB may be the causes.**

These cases should be seen by a medical doctor.

- If AIDS is the suspected diagnosis, this does not alter the treatment strategy: the**

child should be treated as any other child on the programme.

· If tuberculosis is suspected, the decision to initiate treatment should be taken by a doctor and only if there is a fully functioning and well supervised TB programme. Diagnosis of TB in children is difficult (see Ref. 22).

8. Evaluation of feeding programmes

Feeding centres can be evaluated during their operation to see how efficiently they function and to determine which aspects of the programme require the most attention at any time (PROCESS evaluation).

Monitoring the Functioning of a Feeding Centre

MONTHLY ATTENDANCE REPORT

Monitoring the functioning of the feeding centre is based on the monthly collection of clear data on the activities in the feeding centre, including admission and discharge criteria, kcal/person/day distributed, number of meals per day and the attendance pattern of the children.

The attendance book is the basis for the following attendance report:

Attendance report

	< 5 years ($< 110\text{cm}$)	≥ 5 years ($\geq 110\text{cm}$)	Preg. + Lact. Women (SFP)	Total
Total Last Month (A)				
New Admissions (B)				
Readmissions (C)				
- Discharge (D)				
- Death (E)				
- Default (F)				
- Transfer (G)				
Total Exits (H)				
Total End Month (I)				

FIGURE

Total Last Month (A): copy Row I of last month

Total Exits (H): Row D + E + F + G

Total End Month (V: Row A + B + C - H

INDICATORS AS A PROPORTION OF EXITS

Changes in the functioning of the feeding centre can be quickly detected through monthly calculation of several indicators. Most of these indicators can be obtained directly from the attendance report.

In order to facilitate comparison between months and between feeding centres, indicators should be calculated for children under 5 and above 5 years of age

separately (and if other vulnerable groups are included included in the SFP, these should also be graphed separately i.e. pregnant and lactating women).

Function indicators should be expressed as proportions of the total number of children leaving the programme during the reporting month for any reason.

The proportions of the number of exits that each indicator reflects are not real population <<rates>>. For example, the proportion of deaths is not a mortality rate and does not reflect the risk of dying in the population, it indicates the severity of malnutrition in the programme participants and the quality of programme functioning.

- Proportion of Recovered (%): No. of children successfully discharged / No. of exits Row (D) / (H) x 100%**
- Proportion of Deaths (%): No. of deaths in the centre / No. of exits Row (E) / (H) x 100%**
- Proportion of Defaulters (%): No. of defaulters / No. of exits Row (F) / (H) x 100%**
- Proportion of Transferred (%): No. of transferred / No. of exits Row (G) / (H) x 100%**

Absolute Figures from the attendance report can be graphed over time, to help interpretation of trends in programme functioning (see the example in Annex 20).

Interpretation

Analysis of the different function indicators should be done in the field, because proper interpretation can only be made within the specific context. Furthermore,

the information is vital for programme management, allowing appropriate and prompt adaptations, if necessary.

The main advantage of calculating proportions as a function of the number of exits is that these indicators are independent of the number of new admissions, which may greatly vary over time for different reasons (for example as a result of population movements).

The function indicators, as given above, are highly inter-related and should therefore always be interpreted in relation to each other.

For example: an increase in the number of defaulters during the month will result in a decrease in the proportion of recovered and deaths. This does not mean that the functioning of the programme has improved; on the contrary, the increase in defaulting is worrying, and demands attention.

Another example: a decrease in the number of defaulters will result in a increase in the proportion of recovered and deaths. This should not be interpreted as bad functioning of the centre, but as improved functioning; the proportion of successful recoveries will also have increased. In general it can be said that the proportion of recovered is the most important indicator, as it reflects the ultimate objective of the feeding programme.

The table below provides provisional targets and reference figures are given to provide benchmarks against which to interpret the functioning of individual programmes. The target figures should not be considered as rigid objectives for every programme as the feasibility of reaching targets depends on the local

circumstances and the stage in programme development. However, target figures may give an indication of what might be considered <<good>> and <<bad>> functioning under <<average>> conditions.

The proportion of those transferred is usually left out of the analysis as it is usually a minor proportion and only confuses interpretation.

Reference values of proportions of exits

Proportion of exits	TFP Objective	TFP Alarming	SFP Objective	SFP Alarming
Recovered	> 80%	< 50%	> 70%	< 50%
Deaths	< 5%	> 25%	< 3%	> 10%
Defaulters	< 10%	> 25%	< 15%	> 30%

FIGURE

OTHER INDICATORS

· Attendance rate

WET - Average daily attendance over the month / Average No. of children registered over the month = Average daily attendance / Row $\{[(A)+(I)]/2\}$

DRY - Average weekly attendance over the month / Average No. of children registered over the month = Average weekly attendance / Row $\{[(A)+(I)]/2\}$

Objective: > 80%

It is sufficient to only calculate the average attendance rate for a few randomly chosen days during the month. Make sure that a record of attendance in the attendance book corresponds with actual physical presence of the child during meals - to be checked by physical counting of recipients during the meals.

Example. Average attendance rate:

· There are 90 children registered in a TFP:

Attendance on 6 randomly chosen days during the previous month: day 3: 76; day 9: 83; day 11: 79; day 18: 69; day 25: 74; day 28: 81.

- Average attendance = 77

- Attendance rate = $77/90 \times 100 = 86\%$

· There are 1,600 children registered for dry feeding. Attendance over the last month: week 1: 1,250; week 2: 1,116; week 3: 1,120; week 4: 1,050. - Average monthly attendance = 1,134 - Attendance rate = $1,134/1,600 \times 100 = 71\%$ The average child will come 3 out of every 4 distribution days.

· Coverage:

Total No of children < 5 years registered at the end of the month/Total No of malnourished children < 5 years estimated by the last survey. Objective: > 50% in rural populations, > 75% in urban / camp populations

Example of coverage:

- **Total population: 20,000 people**
- **The proportion of children under 5 years is estimated at 20% = 4,000 children**
- **Nutritional survey: 4% of children under 5 years are severely malnourished (c 2 Z-Scores W/H and/or oedema) = 160**
- **17% of children 6-59 months are moderately malnourished**

(W/H- 3 - <-2 Z-Scores): 680 children

- Registered in the TFP: 90
- Coverage: $90/160 \times 100\% = 56\%$
- Registered in the SFP: 430
- Coverage: $430 / 680 \times 100 = 63\%$

Note: The coverage calculated this way will become less accurate over time since the survey was performed, as the prevalence of malnutrition will change. However, there is no alternative until another survey is conducted.

- **Mean length of stay on discharge**

To be calculated monthly or every 3 months, from all recovered children or a random sample of 30 recovered children: total number of days of admission of all (30) recovered children added/No of recovered children (30). Objective: < 30 days for TFP and < 60 days for SFP.

- **Average weight gain: (every 3 months - OPTIONAL):**

The average weight gain of the children in a TFP is a very good indicator of the quality of the programme (it is rarely used for SFPs). It can be calculated every

three months on a sample of 30 children, chosen randomly from the record files.

The weight gain is calculated over the entire period for marasmic children after entry into the Phase II. For kwashiorkor cases, the indicator is calculated in Phase II after complete loss of oedema.

Objective: 10 - 20 g/kg/day

Daily Weight Gain = $W2 - W1$ (g/kg/day) / ($W \times (T2 - T1)$)

W1 = Weight on entry of Second Phase in grams

W2 = Weight at day 15 or on exit of Second Phase (in grams)

W = Weight on entry of Second Phase in kg

(T2 - T1) = Number of days between W1 and W2

Average Daily Weight Gain = Total of daily weight gains of children (g/kg/day) / Total number of children

· Case Fatality

No. of deaths in the centre / Average No. of children registered during the month.

Objective: < 10%

This rate expresses the risk of death for a child attending the programme.

· Percentage of children vaccinated against measles

Objective: 100%

A brief overview of indicators often used for monthly reporting on SFPs and TFPs is presented below:

A brief overview of indicators often used for monthly reporting on SFPs and TFPs is presented below :

REPORTING FORM	STANDARD INDICATORS	COMMENTS/INTERPRETATION
Attendance Report	Total No. last month Total No. this month Total No. admissions Total No. exits	Reflects size and expansion rate of programme (trends in attendance rates need to be graphed over time)
Attendance Rate	% of those children enrolled who actually attend	Reflects the acceptability/ value and accessibility of the programme
Coverage	% of those children enrolled/attending out of estimated number* of the target group	Reflects acceptability/ value and accessibility of the programme
Mean Length of Stay	1. For recovering children 2. For those that die 3. For defaulters	1 + 2 reflect the quality of services. 3 reflects acceptability/accessibility
Weight Gain (optional)	mean weight gain g/kg body wt./month	Reflects the quality of the programme (on a sample of records)
Reasons for Exiting	1. % Recovered 2. % Died 3. % Defaulted 4. % Transferred	1, 2 + 4 reflect programme quality. 3 reflects acceptability/accessibility and quality

(*) : N^o of children expected derived from anthropometric surveys

FIGURE

(*): No of children expected derived from anthropometric surveys**OBSERVATIONS****· Consumption:**

Do the consumption of food, firewood and water correspond with the attendance figures.

· Food quality:

The quality of the food commodities should be checked when received and regularly during storage (expiry date, damaged packing, moisture, mould, vermin). This is especially important for milk - powder. For quality control procedures of dried skim milk see Annex 14.

Hygiene during preparation and distribution of food should be carefully controlled.

· Ration:

Recipe of the HEM/porridge/dry ration:

- Are the quantities of each ingredient correct?**
- Is the volume of the rations per child correct?**
- Are taste and palatability and consistency of the HEM/porridge correct (the HEM/porridge should be tasted regularly)?**

· Staff:

The level of job performance of the staff should match their job descriptions, motivation, loyalty.

Annex 21 is a check list of tasks for the supervision of TFPs. It should be clear to the supervisor which points from this list should be accomplished in the programme.

Monitoring the Effectiveness (Impact) of the Programme (every 3 - 6 months)

The influence of a particular nutritional programme on the health status of a population is not easy to ascertain as other vital sectors (water, shelter, health care, etc.) contribute to well being. Secondly, one needs fairly accurate knowledge of the <<denominator>> or real population size for an impact indicator based on routinely collected data to be correct.

Mortality figures, malnutrition rates and basic morbidity data (routine and epidemic events) are valuable indicators that need to be monitored in emergency situations in order to appreciate needs and adapt programmes. Information can be collected through cross - sectional surveys, but trends in the data can also be used to help follow the impact of the programme.

By regularly monitoring mortality and prevalence of severe malnutrition, the initial objectives/design of the programme can be evaluated and adapted when necessary.

· Mortality rate among children under five:

Of children in the community: through monthly/weekly (under - five) mortality

surveillance (see Annex 1) or a mortality survey.

- Prevalence of severe malnutrition among children under 5 years in the population:**

To be measured by regular nutrition surveys and comparison with results from previous surveys.

Trends in health and nutrition indicators can be related to various and multiple factors. Thus, one might be able to demonstrate a positive trend in improved rates of malnutrition and mortality over the programme period, but it is impossible to prove that the selective feeding programme caused this trend.

However, with well collected information from multiple sources, one can show a very strong association and argue for a reasonable interpretation of the impact of the feeding programme.

When to Close Down Feeding Programmes

When the number of patients is too low to make it efficient to run separate feeding centres, feeding centres should be closed down (< 20 for a TFP and < 30 for an SFP). New cases should then be referred to the nearby hospital or health centre (supply these services with the necessary food, equipment, and technical support, if not available).

Low numbers of participants may not reflect an improved situation but poor accessibility or acceptability of the programme. Therefore, the decision to close down selective feeding programmes should only be made after a nutrition survey

has clearly shown a significant decrease of global acute malnutrition in the population.

Prevalence of global acute malnutrition (<-2 Z-Scores W/H and/or oedema) among children under - five years old should be below 10%.

The following conditions should also be met:

- General food distributions are reliable and adequate,**
- Effective public health and disease control measures are in place,**
- No seasonal deterioration of nutritional status is anticipated,**
- Mortality Rate is low (see Annex 1),**
- The population is stable - no major influx is expected. (See Ref. 12)**

Follow-up nutrition surveys must be planned to detect any deterioration of the situation, even after closure of selective feeding programmes. This is especially important if the overall situation remains unstable.

9. Food management

Food needs

The composition of rations and exact make-up of recipes depends on availability (from donors and local markets) and local acceptability (local food habits) of foods. See Annex 14 and 16 for suitable ration sizes, food commodities used and recipes.

Try to obtain the foods from donors with in - country food stocks:

- **International organizations**
- **Bilateral donations**
- **NGO's (see Annex 4)**

If donors are unable to supply adequate quantities of food or supply essential items rapidly enough, essential commodities (cereals, pulses, oil, sugar) may be bought locally/regionally.

In order to prevent serious disruptions in the programme, due to irregular food supply, each feeding centre/programme should always have its own buffer stock, sufficient to cover needs for one to three months, depending on local storage and supply conditions.

Transport capacity is critical in the planning and location of feeding centres - a normal 4x4 pick-up can carry 1,000 kg, if roads are not too bad.

Calculations of monthly food needs for wet feeding centres should be based on the needs of a child with an average weight of 9 kg:

200 kcal/kg/day x 9 = 1.81/child/day - TFP Depends on food used in wet SFP.

Example:

If the initial survey estimated the number of severely malnourished children at 245, the food to be ordered for one month will be:

DSM: $80g \times 1.81 \times 245 \text{ children} \times 30 = 1058 \text{ kg} = 1.058 \text{ Mt}$ Oil: $60g \times 1.81 \times 245 \times 30 = 794 \text{ kg} = 0.794 \text{ Mt}$ Sugar: $50g \times 1.81 \times 245 \times 30 = 662 \text{ kg} = 0.662 \text{ Mt}$

Estimates are increased by 10% to allow for losses during transport and preparation, so the total amount to be ordered in this example will be: DSM: 1.164 Mt, Oil: 0.875 Mt. Sugar: 0. 728 Mt, Total: 2. 767 Mt. This amount of food will require at least 3 trips by pick-up.

In addition, local foods need to be purchased for meals for carers.

For calculating food needs for one month for dry ration distribution programmes: average attendance: 150 children per week, dry ration for one child per day:

- 270 gram dry premix containing:**
- WSB 140g**
- DSM 50g**
- 1250Kcal + 46g protein sugar 30g oil 50g food needs for one month for 150 children, including an addition of 10% for losses:**

WSB $(140 \times 30 \times 150) + 10\% = 693 \text{ kg}$

DSM $(50 \times 30 \times 150) + 10\% = 248 \text{ kg}$

sugar $(30 \times 30 \times 150) + 10\% = 149 \text{ kg}$

oil $(50 \times 30 \times 150) + 10\% = 248 \text{ kg}$

Total = 1,338 kg

this amount of food can be transported in 2 pick-up loads.

Actual consumption

The actual consumption of the commodities has to be checked in order to:

- **adapt the theoretical calculation of the food needs to the actual needs,**
- **compare the consumption with the number of beneficiaries to control preparation of meals and unexplained losses of food.**

Example of check on the actual consumption:

No. of children registered at the end of the month: 150

Calculated needs for this month (including 10% losses)

WSB	$140 \times 30 \times 150 + 10\%$	= 693 kg
DSM	$50 \times 30 \times 150 + 10\%$	= 248 kg
Sugar	$30 \times 30 \times 150 + 10\%$	= 149 kg
Oil	$50 \times 30 \times 150 + 10\%$	= 248 kg

Actual consumption:

WSB	700 kg	Corresponds
DSM	300 kg	20% Overconsumption
Sugar	200 kg	> 30% Overconsumption
Oil	200 kg	20% Underconsumption

Stock management

Good management of the food stock is essential for the successful performance of a selective feeding programme. The store must be properly locked, foods carefully

stacked and good ventilation ensured. Food stock management should be systematized so that there is stock rotation (old foods used before the new) and there are always sufficient quantities of ALL commodities in the buffer stock.

Only one person should be responsible for the store, and only with his approval can commodities be released from the storehouse; all commodities going in and out of the store must be systematically registered.

The supply and use of the different commodities must be summarized in a monthly stock balance.

Example of a monthly stock balance sheet

Commodity	DSM (kg)	Oil (kg)	Sugar (kg)	WSB (kg)	... (kg)	... (Pcs)
Opening stock						
Supply (In)						
Borrowed (In)						
Loaned (Out)						
Monthly use (Out)						
Losses/Damages (Out)						
Closing stock						

FIGURE

At the end of each month, a physical count (stockcount) of the stocks should be made to cross - check the stock balance. The stockcount should equal the closing stock of the stock balance. If this is not the case, and differences are unacceptable, try to find out reasons and change the food management system

accordingly.

The end - of - the - month stockcount should be taken as the opening stock for the next month.

Food Orders

The required food stock at the beginning of the month will depend on the extent of the predicted consumption as well as the size of the required buffer stock. The frequency and stability of the food supply determines the amount of food needed as a buffer stock. If a stable monthly supply can be guaranteed, a buffer of one month is sufficient (although 2 - 3 may be preferred). Large stocks should be avoided, because the management is more difficult, food has a limited shelf life, and for security reasons.

The quantity of food to be ordered each month, allowing for a one month buffer stock, can be calculated as follows:

Monthly Order = (2 x Monthly Consumption) - Stock Count

Example:

A feeding centre consumes 0.625 MT of sugar every month. There are 0.25 MT in stock at the end of the month. The next order will be: (2 x 0.625) - 0.25 = 1 MT.





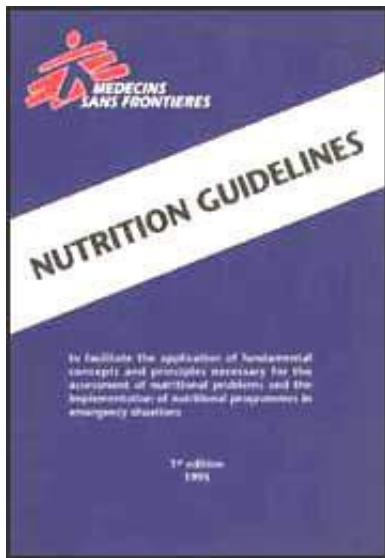





(All food orders should be made in Metric Tonnes = 1000 kg)























Nutrition Guidelines (MSF, 1995, 191 p.)

Annexes

-  **Annex 1: Rapid assessment of the state of health of displaced populations or refugees (A.Moren - Medical News, No. 1)**
-  **Annex 2: Mid - Upper Arm Circumference (MUAC)**
-  **Annex 3: Nutritional status assessment in adults and adolescents**
-  **Annex 4: Agencies involved in food relief**
-  **Annex 5: Food composition table**
-  **Annex 6: GENERAL RATION: How to calculate the energetic value**
-  **Annex 7: Micronutrient deficiencies**
-  **Annex 8: Food basket monitoring methodology**
-  **Annex 9: Analyzing nutritional survey data**
-  **Annex 10: Drawing of a random number**
-  **Annex 11: Standardization of anthropometric measuring techniques**

-  **Annex 12: Data collection forms**
-  **Annex 13: W/H Reference tables**
-  **Annex 14: Selection of food items for selective feeding**

- programmes**
-  **Annex 15: Oral rehydration for severely malnourished children**
 -  **Annex 16a: Preparation of High Energy Milk**
 -  **Annex 16b: Recipes for porridge for use in therapeutic and wet supplementary feeding programmes**
 -  **Annex 16c: Recipes for premix for dry ration supplementary feeding programmes**
 -  **Annex 17a: Example of a Therapeutic feeding centre**
 -  **Annex 17b: example of layout of a <<wet>> supplementary feeding centre**
 -  **Annex 17c: Example of a DRY SFP**
 -  **Annex 18a: Example of an Attendance register (tfp or SFP)**
 -  **Annex 18b: Example of a Nutritional Status Monitoring (SFP)**

 -  **Annex 19a: TFP individual monitoring card**
 -  **Annex 19b: SFP individual monitoring card**
 -  **Annex 19c: Individual card for Supplementary feeding centre**
 -  **Annex 19d: Example of an individual card for dry blanket SFC**
 -  **Annex 20: Feeding programme indicator graphs**
 -  **Annex 22: MSF nutrition kits**

Nutrition Guidelines (MSF, 1995, 191 p.)

Annexes

Annex 1: Rapid assessment of the state of health of displaced populations or refugees (A.Moren - Medical News, No. 1)

GENERAL

The main objective when assisting displaced populations or refugees is quickly to reduce excess mortality ever present in these situations(10). During the first few weeks or the first few months following population displacement (Figure 1a), the death rate observed is often high. It rapidly goes down when intervention becomes organized and coordinated.

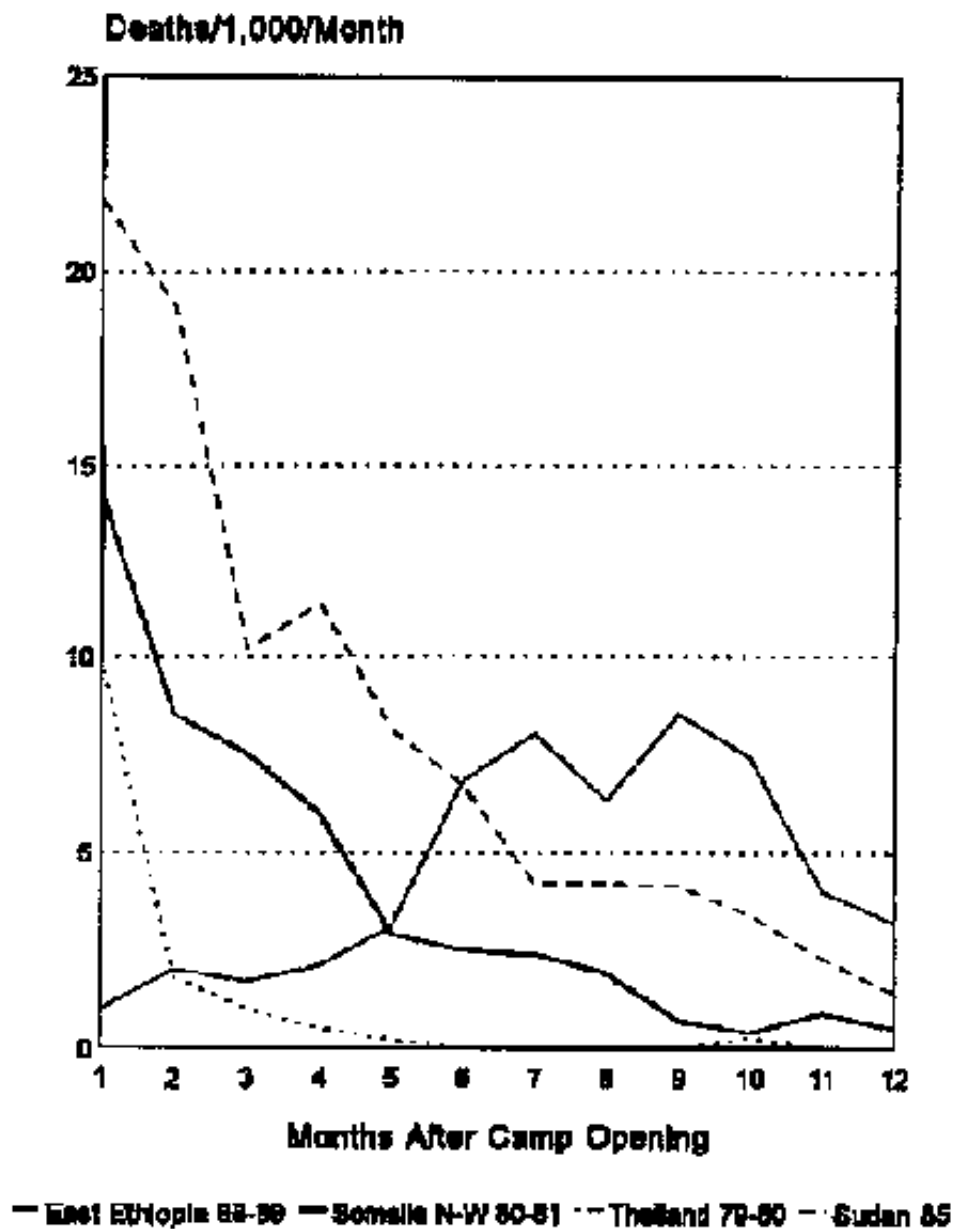

Figure 1a : Crude death rate per month in four refugee situations, 1980-1989 (CDC)

FIG1a:

- East Ethiopia 88 - 89 - Somalia N - W 80 - 81 - Thailand 79-80 - Sudan 85.

Intervention priorities have long since been properly defined and procedures standardized. They may be summarized in ten points:

- 1) Mass immunization against measles**
- 2) A rapid initial evaluation**
- 3) Water supply**
- 4) Food supply**
- 5) Shelter**
- 6) Organize a programme to control diarrhoeal diseases**
- 7) Setting up an epidemiological surveillance system**
- 8) Training community health workers**
- 9) Setting up a curative care unit based on a list of essential drugs and the application of standardized therapeutic protocols**
- 10) Coordinating the various operational partners.**

The first four interventions can, and must, be carried out simultaneously (6). This is all the more easy as such activities are conducted by groups of different specialists (health care staff, epidemiologists and logistics experts).

METHOD

If an intervention is to be fast, effective and properly suited to the situation, it must be based on an initial evaluation which has to be conducted in the early days after the displaced populations have arrived or are taken charge of. The preliminary results from such an evaluation have to be available in the week

following the start of the evaluation.

The data to be collected relate to: the background to the displacement, security conditions, site mapping, demography, mortality, nutrition, priority pathologies, water and food resources, housing, sanitation, climate, the road network and available resources.

There are three ways in which these data may be gathered:

- Mapping It is important to count the number of people quickly and ascertain the structure of the population. A rough map of the site can be drawn rapidly by squaring out the camp and making measurements on foot or in a car. Using squared paper, the sections or zones making up the camp may be drawn (Fig. 1b).**

Once the map has been produced, a 100m - by - 100m grid is superimposed. Each of the squares is then classified as a low - medium - or high density population square. Then two or three squares are drawn by lots from each category of zone density. Each of the selected squares is then visited to make a population count. This gives an average number of refugees per low, medium and high density population zone of refugees. The number of people in the low density squares is multiplied by the number of such low density squares. The same operation is repeated for each of the other density categories (Fig. 1b). This method makes it possible to produce an estimate of the aggregate number of refugees on the site.

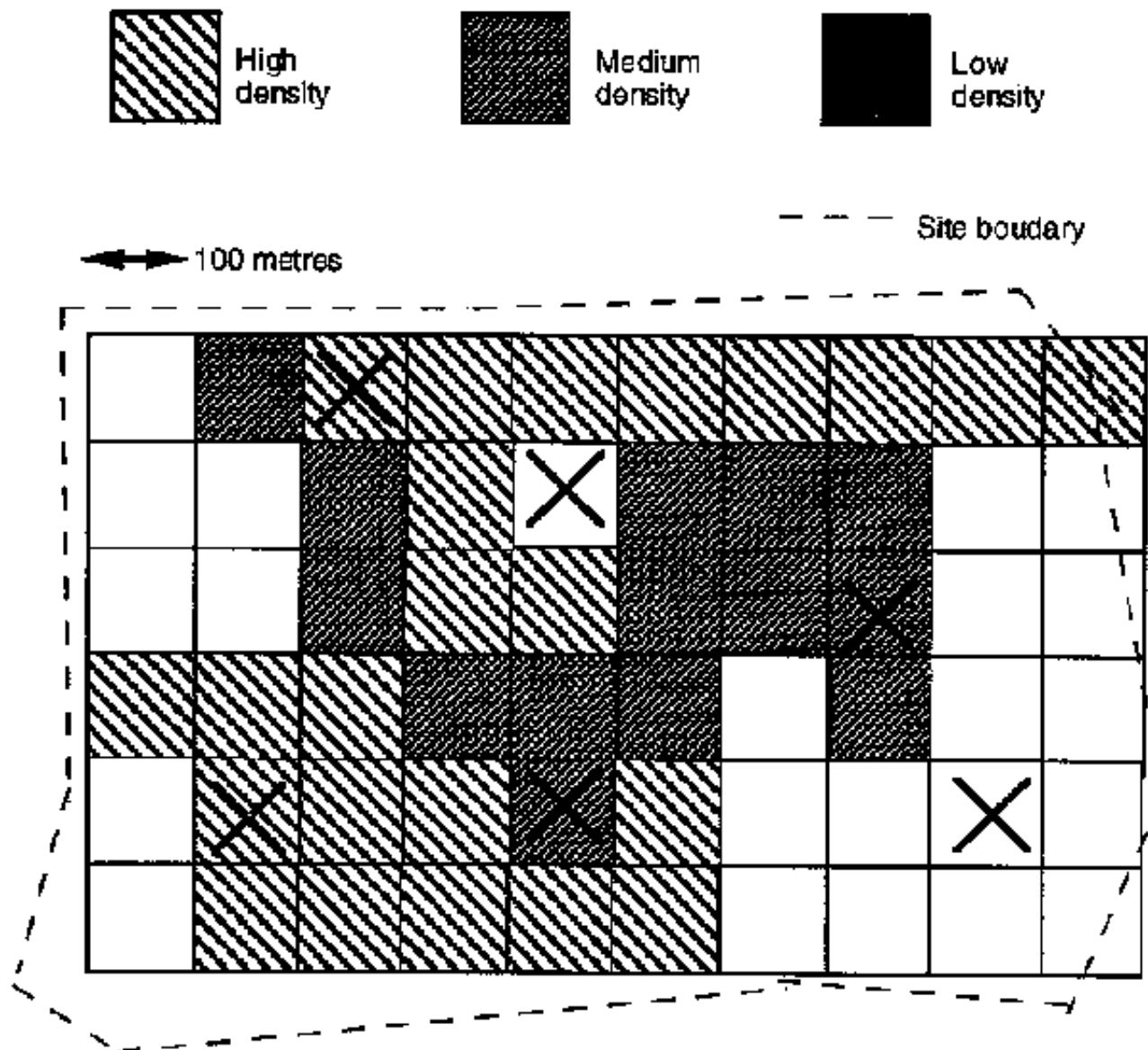

Figure 1b : Mapping out a population

FIG. 1b:

The number of litres of water available per person and per day can be assessed on the basis of the number of watersupply points and measurements of their respective capacities(3). This is an operation that can be carried out as the map is being drawn.

· Sample survey

The following information may then be obtained using a sampling technique within the population. A simple random type of sampling can be used if the households are numbered (drawing lots); the systematic type if the households are organized into rows or properly ordered geographical zones; or the two stage cluster sampling survey type if the site is not organized geographically (2). The size of the sample is a compromise between the urgency of the expected result and the desired accuracy. It is advisable to take at least 200 households.

In each household selected, the number of individuals is recorded, together with the age and sex of each one. For children aged 6 to 59 months old, their weight, height and mid - upper - arm circumference are measured(2). Each head of household is questioned about the number of deaths in the household over the previous months. Using a verbal autopsy questionnaire, the causes of death are determined(9).

The type of dwelling (huts, tents, permanent housing, open air) is noted. Food stores are estimated by weighing the food available on the day of the enquiry. The food intake of the previous day may be measured by using a 24 hour food intake summary (the quantity of food eaten the previous day by the individuals in the sample is estimated for each type of food and the calorie intake is established

using food tables - Annex 5).

The date of the last food distribution operation is also noted. The existence of latrines, the distance to the nearest water supply point and its type will be noted (3).

· Interviews with the leaders of organizations present and those of the various communities

Human resources are to be determined (numbers of doctors, nurses, water, hygiene, sanitation specialists, logisticians and available community health care workers).

The total number is expressed as a ratio of the aggregate population and is compared to advocated staff levels (6, 10).

Interviews with the host country authorities provide information on the background to the displacement and security conditions. In the same way, information is gathered on the date(s) of the rainy season(s), the possibility of roads and expected temperatures (6).

Once these data have been collected, they are summarized in a preliminary report in the form of a table showing the main indicators (computed from the data as above) and the comparison thresholds. One page suffices to summarize the data. The purpose here is to be convincing by using the figures and to trigger the rapid adjustment of any assets made available.

Often the list of relevant information proves impossible to complete within a

week. If a choice has to be made, priority is given to the collection of data on the number of refugees, the daily mortality, the food ration distributed and water supply.

This initial evaluation also serves to set up an epidemiological surveillance system (5). The most important indicator to be monitored is the daily mortality, expressed as a number of deaths per day per 10,000 people. The number of deaths may be obtained by making a daily count of the new graves on the site and by regularly questioning the community leaders.

The system may also be based on the work carried out by the community health care workers in each section in the camp as they record the number of deaths occurring in their section each day or each week. A simple weekly data collection sheet is used. A simple daily or weekly mortality graph also has to be filled in (Annex I c).

Figure 1c: Daily mortality rate

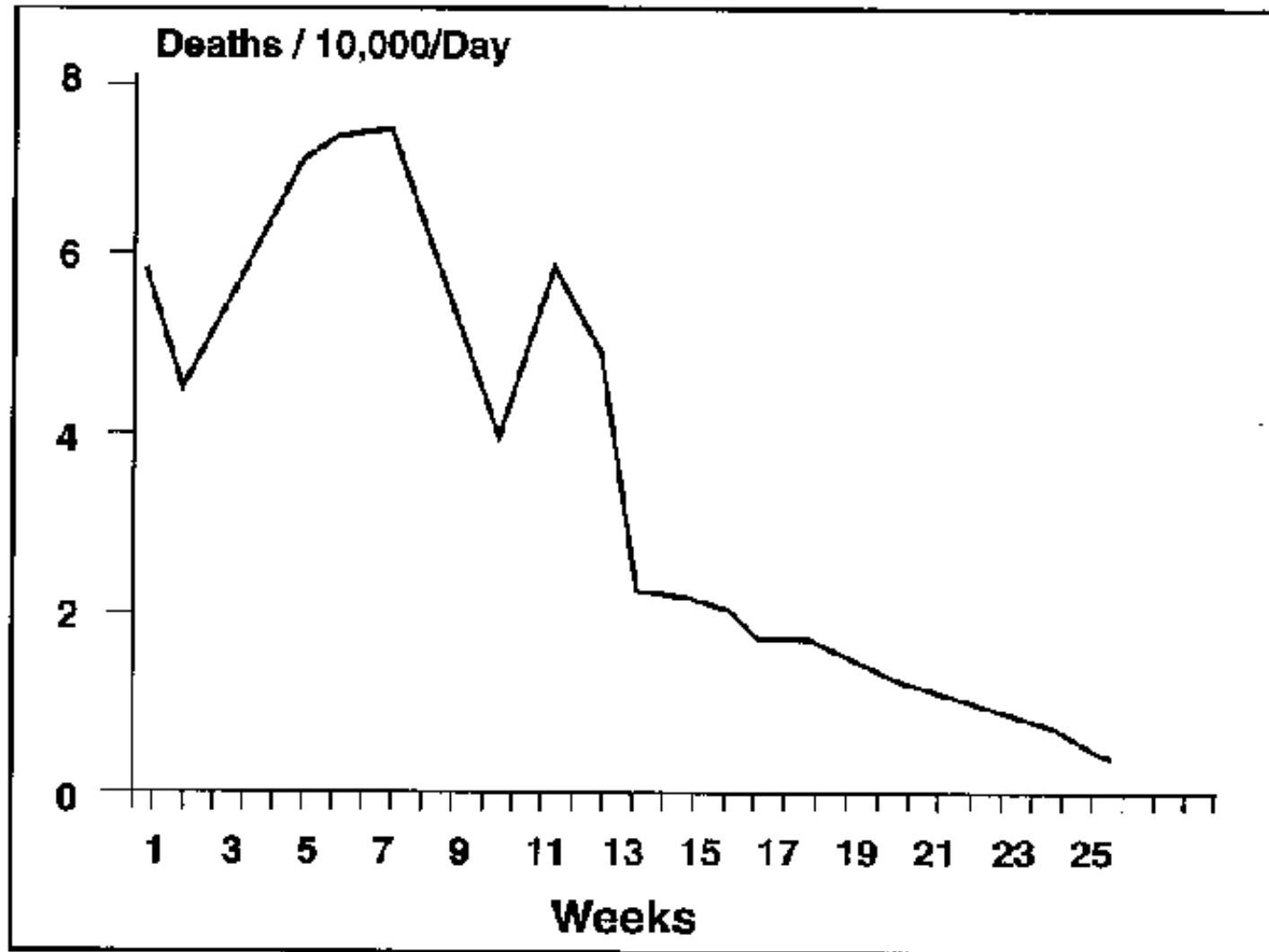

FIG. 1c:

Example of a of rapid assessment report:

Place: XXXX

Dates: 12110192 - 19110192

Person responsible: XX**Method:****1) Mapping/grid****2) Sampling (clusters), 200 households, N = 900****3) Other sources of information: WFP, UNHCR.****Results:**

	Observed	Theoretical
Total number of refugees	55,423	-
% of children under the age of 5 years (if need be, age pyramid)	14.5%	20%
% 6 - 59 months with a MUAC < 12cm	15.5%	7%
Number of deaths per 10,000 people per day computed for the previous month.	6	< 1/0,000

Breakdown of causes of death

Measles	35%	-
Diarrhoea	25%	-
Malnutrition	22%	-
Acute respiratory infections	5%	-
Malaria	0%	-

Epidemic pathologies present

Cholera	NO	
Meningitis	NO	
Measles	YES	
Available daily food ration	1500	2100 Kcal
Average number of litres of water available per person and per day	45	>20L
Number of people per latrine	50%	<20
% of people with a protected dwelling	100%	
Number of doctors/10,000 persons	0.5	1
Number of nurses/10,000	1	2
Number of logisticians	0.2	1
Number of sanitation workers/10,000	0.2	1
Number of city health workers/10,000	5	10

CONCLUSION

The purpose of a rapid evaluation is to provide guidance for setting up emergency operations in the shortest possible time. Methods will often be approximate and results will have to be corroborated with remote in depth studies. The initial evaluation report is an item of paramount importance. It needs to be brief, concise, precise, fast and it should provide only figures.

Alain Moren, Epicentre, October 1992

References

- 1. Famine Affected, refugee, and displaced populations: recommendations for public health issues. CDC. MMWR 1992; 41(No.RR13).**
- 2. Enquetes anthropometriques au sein de populations en situation precare., Coulombier D. EPICENTRE/MSF, 1991.**
- 3. Technicien Sanitaire en Situation Precare, MSF, 1992, Courvalet M., Delmas G.**
- 4. Public health consequences of the civil war in Somalia, Manoncourt et al. LANCET (letter), 1992; 340:176177.**
- 5. Epidemiological surveillance among Mozambican refugees in Malawi, Moren A. and al. DISASTER**
- 6. Populations refugiees: Priorites et conduites a tenir. Cahiers Sante, Moren A, Rigal J. 1992; 2:13 - 21.**
- 7. Public health consequences of acute displacement of Iraqi citizen, Pecoul B., Malfait Ph. Toole MJ, Waldman RJ. - March - May 1991. MMWR 1991; 40:4436**
- 8. Refugee Community Health Care., Simonds S.et al. Oxford Medical Publication, 1983.**
- 9. Methods For Field Trials Of Interventions Against Tropical Diseases, Smith PG, Morrow RH, Oxford Medical Publications. 1991; Ch 8:169175.**

10. Prevention of excess mortality in refugee and displaced populations in developing countries, Toole MJ, Waldman RJ. JAMA 1990; 263: 3296302. Tableau I.

Note : Benchmarks for the Interpretation of Mortality Rates

Crude Mortality Rate (# deaths/10.000/Day)	Interpretation
0.5	Normal Rate : developing countries*
< 1	Relief Programme : under control
1 - 2	Relief Programme : very serious situation
> 2	Relief Programme : out of control
> 5	Relief Programme : major catastrophe

* Most Sub-Saharan African countries have a CMR of 15/1000/Year which is a rate of 0.4/10.000/Day.

TABLE:

CUT - OFF POINTS FOR THE INTERPRETATION OF UNDER 5 MORTALITY RATES ARE APPROXIMATELY DOUBLE THOSE OF CMR CUT - OFFS.

Annex 2: Mid - Upper Arm Circumference (MUAC)

1. Taking the measurement

MUAC should be measured on the left arm, while the arm is hanging down the side of the body and is relaxed. The MUAC should be measured at the midpoint between the shoulder and the tip of the elbow.

The end of the tape is fed down through the first window and up through the third window, and the measurement is read from the middle (second) window.

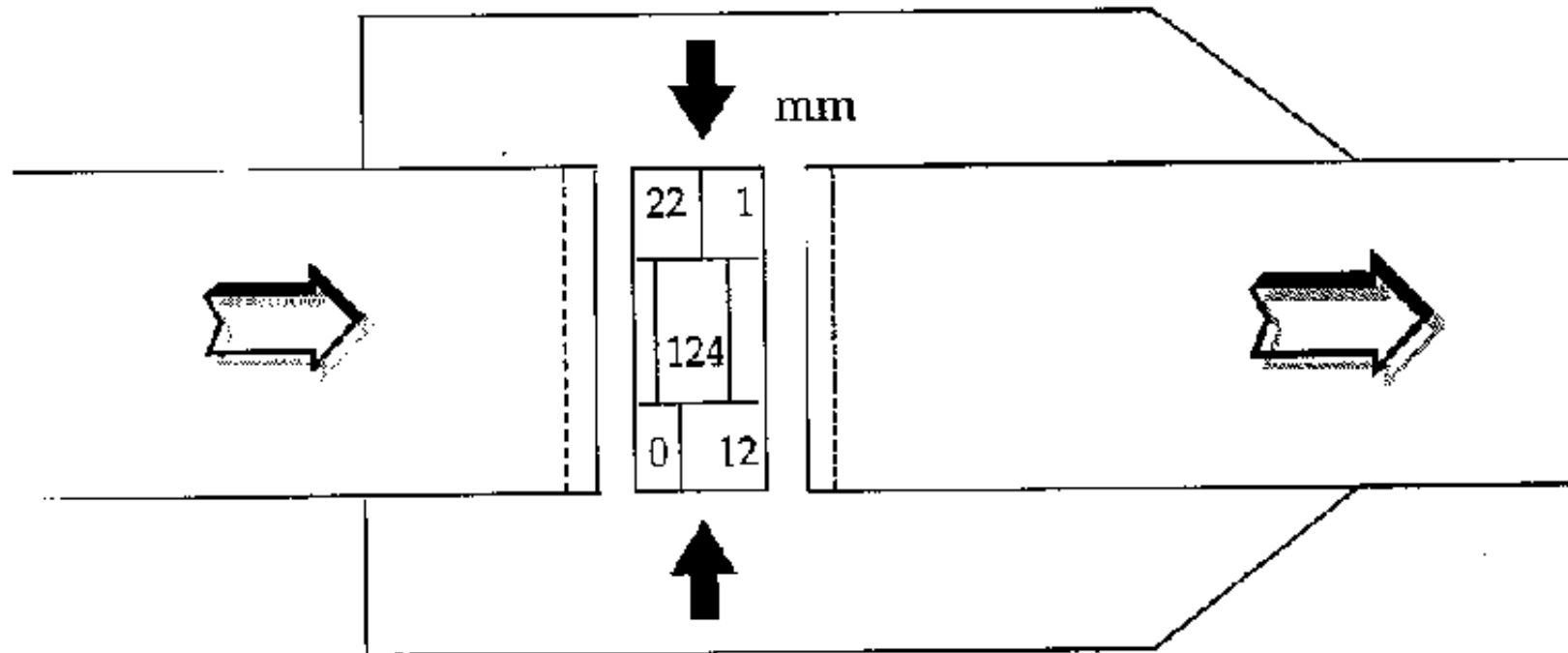

FIGURE

2. Reading the measurement

MUAC can be recorded with a precision of 1 millimetre. Read the number in the box which is completely visible in the middle window.

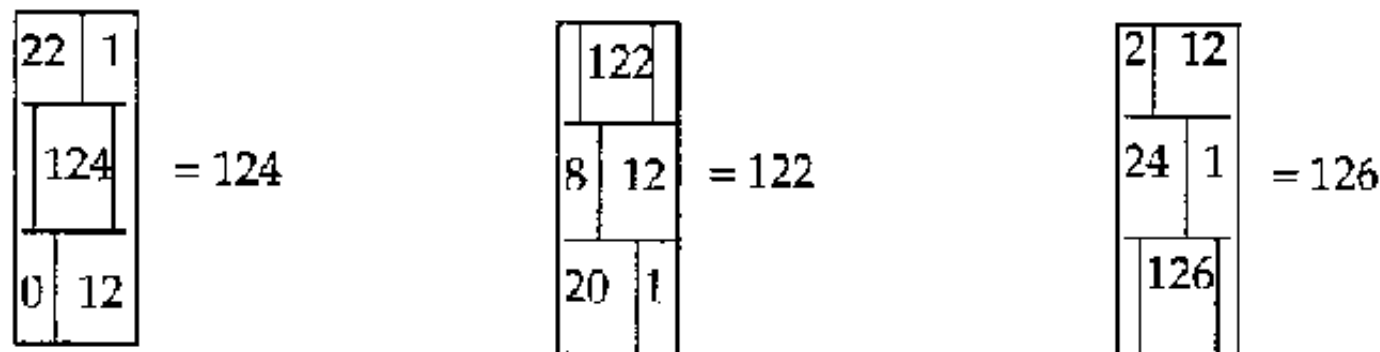
**FIGURE**

3. Interpretation

Contrary to the weight for height indicator, there is not 1 set of universal cut - off points for interpreting MUAC. There is agreement between the different MSF sections and Epicentre to use the following cut - off points:

< 110 mm = Severe acute malnutrition

110 to 124 mm = Moderate acute malnutrition

At the population level, these cut - offs give broadly similar results to the estimate of the prevalence of acute malnutrition as accepted weight - for - height cut - off points. At the individual level MUAC and W/H are not comparable. For entry to nutrition programmes we use W/H, but as MUAC is faster to perform we can measure all children with MUAC and only refer those children

< 135 mm

to the second stage where they are measured for W/H to see if they can enter the

programme.

4. Interpretation with colours

Colour bands are included on the tapes so that illiterate workers may use the tapes to classify children's nutritional status.

RED = Severely acutely malnourished

ORANGE = Moderately acutely malnourished

YELLOW = To be referred for weighing and measuring

GREEN = Normal

For mass screenings as long as the reading window is completely green, the children are not referred for further assessment (W/H).

For quick surveys, it is necessary to note down the proportion of children falling in the ORANGE and RED bands (but for a survey it is better to record actual measurements if possible).

Annex 3: Nutritional status assessment in adults and adolescents

The weight - for - height indicator can only be used to 137 cm (+/- 10 years). Furthermore, adults are less prone to malnutrition and the effects of malnutrition are less harmful in the short and longer term. Nevertheless, in severe nutritional emergencies adult malnutrition can be an important problem.

Body Mass Index (BMI) is used as an indicator for adult nutritional status. BMI is

an indicator that is supposed to reflect thinness, by measuring weight and controlling for height. BMI is calculated as weight / height²

WHO proposes the following BMI cut - off points:

16 - 18.5: AT RISK

<16: MALNOURISHED

These cut - off points were based on European populations and there are difficulties in using one set of cut - off points universally. Due to genetic and environmental factors, many African populations have, on average, a lower BMI than European populations, even during optimal nutritional status. This is mainly due to the fact that many African populations have a smaller body frame size and a longer relative leg - length.

More appropriate reference figures have been proposed, taking into account sex and frame size, but the BMI still depends on factors other than the nutritional status, such as height and relative leg - length. Therefore, BMI is usually used as a relative indicator, to indicate progress or deterioration in the population's nutritional status, over time.

For individual follow-up, weight gain or loss is the preferred indicator.

BMI can only be used in adults, having reached full maturity. The age of onset of maturity may be later in developing countries, so BMI must be used with caution when dealing with younger adults and avoided for use with adolescents.

The lack of clearly defined standards for assessing adult malnutrition is a cause of great concern. Of even greater difficulty is the assessment of adolescent malnutrition. Intervention in war situations inevitably leads to contact with broadly malnourished populations. Intervening in situations of mass adolescent and adult malnutrition is a major responsibility for which we are not well equipped.

Nutritional oedema in adults is rare and will only occur in severe famines. It should always be interpreted with caution, as other causes of oedema may occur.

Body mass index (Adults) (- W/H²)
Body weight corresponding to specified BMI, for given height

Height (cm)	BMI			Height (cm)	BMI		
	18.5	17.0	16.0		18.5	17.0	16.0
	Minimum normal	Mod. underwt.	Severe underwt.		Minimum normal	Mod. underwt.	Severe underwt.
	Body weight in Kg				Body weight in Kg		
140	35.2	33.3	31.4	165	49.8	46.3	43.6
141	35.8	33.8	31.8	166	51.0	46.8	44.1
142	37.3	34.3	32.3	167	51.6	47.4	44.6
143	37.8	34.8	32.7	168	52.2	48.0	45.2
144	39.4	35.3	33.2	169	52.8	48.6	45.7
145	39.9	35.7	33.6	170	53.5	49.1	46.2
146	39.4	36.2	34.1	171	54.1	49.7	46.8
147	40.0	36.7	34.6	172	54.7	50.3	47.3
148	40.5	37.2	35.0	173	55.4	50.9	47.9
149	41.1	37.7	35.5	174	56.0	51.5	48.4
150	41.6	38.2	36.0	175	56.7	52.1	49.0
151	42.2	38.8	36.5	176	57.3	52.7	49.5
152	42.7	39.3	37.0	177	58.0	53.3	50.1
153	43.3	39.8	37.5	178	58.6	53.9	50.7
154	43.9	40.3	37.9	179	59.3	54.5	51.3

155	44.4	40.8	38.4	180	59.9	55.1	51.8	
156	45.0	41.4	38.9	181	60.6	55.7	52.4	
157	45.6	41.9	39.4	182	61.3	56.3	52.0	
158	46.2	42.4	39.9	183	62.0	57.0	53.6	
159	46.8	43.0	40.4	184	62.6	57.6	54.2	
160	47.4	43.5	41.0	185	63.3	58.2	54.8	
161	48.0	44.1	41.5	186	64.0	58.8	55.5	
162	48.5	44.6	42.0	187	64.7	59.5	56.0	
163	49.2	45.2	42.5	188	65.4	60.1	56.6	
164	49.8	45.7	43.0	189	66.1	60.7	57.2	
				190	66.8	61.4	57.8	
	A	B	C	D	A	B	C	D

Interpretation :

BMI < 16.0 (interval D) signifies severe leanness

BMI 16.0 - 16.9 (interval C) signifies moderate leanness

BMI 17.0 - 18.4 (interval B) signifies marginal leanness

BMI 18.5 - 24.9 (interval A) is the normal range for an individual.

Source : WHO (1994)

FIGURE**Annex 4: Agencies involved in food relief**

Although there are various agencies involved in relief food assistance, the U.N. agencies are most often present and have a constant mandate:

I / UNITED NATIONS AGENCIES:**1. World Food Programme (WFP/PAM)**

The main agency concerned with food aid among the UN family - WFP has various sources under which it operates, depending on the situation:

- **Special fund for food assistance to refugees and displaced persons.**
- **Fund for emergency operations: natural and man - made catastrophes, drought and harvest failure.**
- **Management of the International Emergency Food Reserve (IEFR).**

WFP will donate food to NGOs for a variety of reasons. Food items that are a part of the general ration will be available to NGOs for feeding of in - patients at hospitals, feeding mothers accompanying children in the feeding centre and Food For Work (FFW) for staff. Other supplies (i.e. oil, sugar, CSB) can also be received for feeding programmes.

In some circumstances, WFP will pay an internal transport, storage and handling allowance. Check with the WFP country - office for available options.

WFP also has a large presence in development assistance.

2. United Nations High Commission for Refugees (UNHCR)

UNHCR is responsible for the coordination of relief assistance to international refugees and the protection of their rights.

The degree to which UNHCR is responsible for the actual food supply to the refugees depends on the situation - UNHCR is dependent on other organizations for supply of food aid (usually WFP) and brokers agency responsibilities in each different situation.

WFP usually has the responsibility for the supply of the general food ration and UNHCR might complement the food basket with additional food items (i.e. fish, meat, spices). The actual delivery of the food aid will be coordinated by one of the agencies, but its distribution is often subcontracted to other agencies (Care, Red Cross/Crescent, Oxfam, SCF, CARITAS, CRS, etc.). The supply and delivery of supplementary and therapeutic foods will usually be under the responsibility of UNHCR.

UNHCR also has a mandate to assist the displaced, but its resources and legal powers are limited and UNHCR does not play a lead role in this respect. For nonrefugees (e.g. displaced persons), WFP will often provide food assistance through other UN agencies (e.g. UNICEF) or even NGOs.

3. United Nations Children's Fund (UNICEF)

UNICEF focuses on the welfare of children. UNICEF is the UN agency with the greatest amount of autonomous resources and will often become involved with funding or coordinating special programmes to meet needs unmet by the other agencies.

Unicef can be requested to provide blended food (i.e. UNIMIX), material for feeding centres (balances, cooking utensils, essential drugs, etc.). The response will depend on the level of autonomy and the local policy of the country UNICEF office however, a well presented proposal has a good chance of funding. UNICEF also occasionally has funds for local purchase of food items and transport costs.

Investigate the current national policy on food assistance (sometimes agreements

with WFP or other agencies) and what delays to expect.

II. OTHER AGENCIES:

· Bilateral donors, such as the EEC, USAID and others often provide food assistance of various kinds to developing countries.

The EEC food aid is essentially divided into two categories: - Fund for Food Aid (FAA) - Fund for Emergency Aid (FAU/ECHO)

FFA food destined for NGOs is channelled through Euronaid.

· Some NGOs also have special access to sources of food aid which they import independently, either received from bilateral donors, or purchased with their own funds (particularly CARITAS, CARE, CRS, ADRA, SCF, OXFAM, LWF, ICRC).

Annex 5: Food composition table

Annex 5: Food composition table

CEREALS	KCal	Protein (g)	Fat (g)
Wheat	330	12.3	1.5
Wheat flour	350	11.5	1.5
Bulgur wheat	350	11.0	1.5
Maize	350	10.0	4.0
Maize meal	360	9.0	3.5
Sorghum	335	11.0	3.0
Rice	360	7.0	0.5
Roller oats	380	13.0	7.0
BLENDED FOODS			
Corn soya Blend CSB	380	18.0	6.0
Corn soya milk CSM	380	20.0	6.0
Instant corn soya blend	365	12.2	4.0
Wheat soya blend WSB	370	20.0	6.0
Soy fortified bulgur wheat	350	17.0	1.5
Soy fortified corn meal	360	13.0	1.5

Soy fortified rolled oats	375	21.0	6.0
Soy fortified wheat flour	560	16.0	1.3
PULSES			
Dried peas and Beans	335	22.0	1.5
Dry Groundnuts	590	27.0	45.0
Fresh Groundnuts	350	15.0	25.0
MILK, CHEESE, EGGS			
Dried Skim milk (DSM)	360	36.0	1.0
Dried Whole Milk (FCM)	500	26.0	27.0
Cheese	305	22.5	28.0
Dried Eggs	575	45.5	43.5
MEAT AND FISH			
Canned meat	220	21.0	15.0
Dried salted fish	270	47.0	7.5
Canned fish in oil	305	22.0	24.0
Fish protein concentrate	350	75.0	10.0
OIL AND FATS			
Vegetable oil	885	0	100
Butter oil	860	0	98.0
Margarine	735	0	82.0
Red Palm oil	891	0	100
Edible fat	900	0	100
FRUIT AND BEVERAGE			
Dried fruit	270	4.0	0.5
Dates	245	2.0	0.5
Juice	265	0	0
Tea	0	0	0
Coffee	0	0	0
BISCUITS AND MISCELLANEOUS			
BP 5	452	16.7	13.5
Sugar	400	0	0
Iodized salt	0	0	0
Pasta	365	12.5	1.2
Freeze-dried meat	480	55.0	25.0
Muesli	500	22.5	27.0
Protein enriched ration	450	15.7	15.5

Approximate nutritional values of commodities per 100g of edible portion
Source: LONGHURST, 1992.

FIGURE

Annex 6: GENERAL RATION: How to calculate the energetic value

1. List the different items with Weir caloric value, fat and protein content.

2. Calculate the total number of calories and the protein content of the ration.
3. Calculate the relative percentage of calories provided by each item.

In order to make these calculations, we need information on the average caloric value and protein content of some common relief foods (see the food composition table in Annex 5).

Example : A general food ration may consist of :

FOOD	QUANTITY (g/day)	Kcals	PROTEIN (g)	FAT (g)
Sorghum	400	1340	44	12
Oil	40	354	0	40
Groundnuts (Fresh)	100	330	15	25
TOTAL	540	2024	59	77

FIGURE

1 GRAM OF PROTEIN = 4 Kcals

1 GRAM OF FAT = 9 Kcals

Proportion of Kcal provided by protein:

- **Number of KCal: $59 \times 4 = 236$ KCal**
- **Proportion: $(236/2024) \times 100 = 11.7\%$**

Proportion of Kcal provided by fat:

- **Number of KCal: $77 \times 9 = 693$ KCal**
- **Proportion: $(693/2024) \times 100 = 34.2\%$**

Annex 7: Micronutrient deficiencies

Protein-Energy Malnutrition is not the only form of malnutrition. Deficiencies in micronutrients can occur without signs of acute PEM, with important functional consequences and increased risk for the morbidity and even mortality of the population affected.

From an analysis of the composition of the food ration, it is possible to predict the presence of micronutrient deficiencies. One should not wait for clinical manifestations of micronutrient deficiencies to advocate more adequate food rations.

Certain food storage and preparation techniques may destroy or diminish the micronutrient content of food items. The treatment of food should also be considered when assessing micronutrient content of rations.

Before embarking on prevalence surveys of micronutrient diseases, consult the medical department at head quarters. There are many methodological problems with estimating prevalence of micronutrient deficiencies:

- **A standard case definition is imperative.**
- **Estimation cannot be combined with anthropometric surveys.**
- **There is a need for a large sample size.**

WHAT TO DO ABOUT MTCRONUTRIENT DEFICIENCIES?

- **Provide individual treatment and secondary prevention for the identified cases.**
- **If deficiency diseases are prevalent on a large scale, use the population approach:**

- **advocate changes in general ration composition and quantities;**
- **consider technical possibilities and costs of food fortification;**
- **stimulate garden projects etc.;**
- **mass supplementation of the population with vitamin tablets;**
- **vitamin supplementation outreach campaigns through health service activities (feeding centres, OPD, vaccination campaigns);**
- **it is important to monitor the extent and trends in the disease.**

We list here the most important and most frequent deficiencies that occur in emergency situations. Most are concerned with a lack of vitamins, some with a lack of essential minerals. Full details on biochemical mechanisms and clinical pictures can be found in reference works.

1. Vitamin A deficiency:

Xerophthalmia and night blindness are the main identifiable symptoms of severe vitamin A deficiency; look for so - called <<Bitot - spots>> (dry patches on the conjunctive). Adequate supply of vitamin A is essential as recent studies have

shown that subclinical vitamin A deficiency leads to increased risk of death.

2. Vitamin B1 (thiamine) deficiency:

Beri - beri is the full clinical picture of a deficiency of Vitamin B1. There are two different clinical pictures of beri - beri:

*** <<dry>> beri - beri: bilateral peripheral polyneuritis, with evolution to flaccid paralysis.**

*** <<wet>> beri - beri: cardio - vascular syndrome with oedema and heart failure.**

Early deficiency symptoms are less specific: fatigue, anorexia, abdominal discomfort.

3. Vitamin C (ascorbic acid) deficiency: Scurvy: typical signs are painful joints and swollen, bleeding gums and possible petechia or haemorrhages. A trial treatment with high doses of Vitamin C should rapidly alleviate the symptoms.

4. Vitamin B3/PP (Niacin) deficiency:

Pellagra is recognized by the "3 Ds": Dermatitis, Dementia, Diarrhoea. The typical skin lesions (dark and dry) are on sun - exposed parts (neck, face and arms).

5. Vitamin B2 (riboflavin) deficiency: The most characteristic finding is angular stomatitis. Other mucocutaneous symptoms may be accompanying symptoms.

In the table below an outline of the approximate needs and treatments are given (average values for adults; for children adaption is needed):

Micronutrient	Recommended Daily Allowance (RDA)	Preventive Treatment	Curative Treatment
Vitamin A	1g or 3333 IU per day	200.000 I.U. every 4-6 months (*), and through diet	200.000 I.U. day 1, 2, 7 (*)
Vitamin B1 (Thiamine)	1.2-1.5 mg/d	Provide through diet (fortified foods)	200mg/d IM 3days, then 250mg/d p.o.
Vitamin C	30-60mg/d (min.10 mg/d)	50- 100 mg/day or 500 mg/week, and through diet	0.5-1g/day for 2 weeks, then 2 wks. preventive dose
Vitamin B3 (PP, Niacin)	18mg/d	Provide through the diet (fortified foods)	Niacinamide 300-1000mg/d
Zinc	15mg/d	Provide through the diet (fortified foods)	FeSO ₄ + Folic acid
Iodine	0.1mg/d		
Vitamin D	300-400 IU/d		
Iron	10mg/d		

(*) Vitamin A : if 6 months to 1 year or < 8kg bodyweight : 100.000 IU only.

FIGURE

Annex 8: Food basket monitoring methodology

The objective of FBM is to regularly check food distributions in order to advocate better quantity and quality of rations if required and provide information regarding

the quality of distribution activities. As the issue is highly sensitive, we must be sure of the validity of our information and be careful how we use it to promote the rights of the populations with whom we work.

The method we describe below aims to check if families have received what they are entitled to receive - this does not mean that they will consume all the food (they can sell part of it), or that the food will be fairly distributed among family members.

This method is only applicable if distribution is done to the head of the household at central distribution points, which is not always the case !

IN PRACTICE:

- 1. Choose a point at a <<strategic distance>> from the distribution point, where you post two monitors and one supervisor, with a 50 kgs and a 5 kgs balance. Have two monitors present at the distribution point itself, to select the families.**
- 2. A random systematic sample of 30 families is drawn from all families receiving food at the distribution point. The selected family receives a ticket and is accompanied to the point where the ration will be weighed. (e.g. If 500 families have to attend today, you will measure the ration of every $500/30 = 16$ th family. It is always better to have 3 or 4 families more than the 30 requested.)**
- 3. Get accurate information on the time elapsed since the last distribution.**
- 4. Determine the number of people in the family.**

- 5. Weigh all food items separately and note their weights on the survey form (see below).**
- 6. Afterwards, calculate the energetic value and the protein content of the <<average>> ration. Use a list of nutritional values for different food commodities as in Annex 5.**
- 7. Report the result as an average general food ration in Kcals/Person/day. Calculate the confidence interval.**

$$\text{C.I.} = 1.96 \times S/n^{1/2}$$

where S is the standard deviation of the sample and n is the number of families in the sample.

Incorporate this information with other food distribution information obtained from other sources in a << food basket monitoring report >> (results can be illustrated graphically).

- 8. Repeat FBM on a regular basis and plot the results on a graph to monitor trends in food distribution.**

INTERPRETATION

- Food rations may not be equally distributed throughout the day. Commodities may run out, meaning some families get less towards the end of the day (this should be noted and reported).

- **Different population groups may receive different levels of rations. Poorly serviced population segments must be identified and reported.**
- **The periodicity of distribution may be irregular, making it hard to calculate a daily ration. Different commodities may be distributed on different days. Regularity of distribution is as important as overall quantity, and irregularity is important to be reported.**
- **The most important bias to exclude is that by doing FBM, you influence the behavior of the distributors (i.e. because they know they are being <<controlled>>, they might give more to the families who will be checked). A way of avoiding this would be to give tickets to be measured to 150 families instead of 30, and at the measuring point you take only one in five families.**

Example of FBM survey form

FOOD BASKET MONITORING at site		*****			
On date	:	DATE / YEAR / YEAR			
Date of previous distribution	:	DATE / YEAR / YEAR			

Number	Family Size	Wheat Flour (kg)	Lentils (kg)	Sugar (kg)	Oil (l)
1					
2					
3					
4					
...					
30					
...					
TOTAL					
g/Pers./Day					

FIGURE**Annex 9: Analyzing nutritional survey data***Annex 9: Analyzing nutritional survey data*

Survey data should be analysed according to a pre-defined and standard plan.

1. Interpretative analysis

- Distributions

**Distributions according to age and sex
6-59 month old children, region X, period Y**

	Boys		Girls		Total	
	n	%	n	%	n	%
6 - 17 months						
18 - 29 months						
30 - 41 months						
42 - 53 months						
54 - 59 months						
Total						

Distribution according to weight/ height index in Z-Score or presence of oedema, by age 6-59 month old children, region X, period Y

	< -3 Z Scores		≥-3 & <-2 Z Scores		≥-2 Z-Scores		Oedema	
	n	%	n	%	n	%	n	%
6 - 17 months								
18 - 29 months								
30 - 41 months								
42 - 53 months								
54 - 59 months								
Total								

Similar tables should be used to describe the distribution of any other variables investigated.

– Indicators

- Proportion of children presenting oedema : %
- Acute global malnutrition (defined by an index < -2 Z-Scores or presence of oedema) : % with a 95% confidence range for this estimate : % to %.
- Acute severe malnutrition (defined by an index < -3 Z-Scores or presence of oedema) : % with a 95% confidence range for this estimation (corrected) : % to %

2. Interpretative analysis

**Distribution according to nutritional status and age
6-59 month old children, region X, period Y**

	Global acute malnutrition		
	Prop.	from	Confidence interval to
6-29 month children	%	from% to ...%
30-59 month children	%	from% to ...%

FIGURE

**Distribution according to nutritional status and date of arrival
6-59 month old children, region X, period Y**

	Global acute malnutrition		
	Prop.	Confidence interval	
Last arrived	%	from	... % to ... %
First arrived	%	from	... % to ... %

FIGURE

Similar tables should be used to present analyses that show different rates of malnutrition by other important variables (i.e. ethnic groups, refugees compared to residents).

While interpretive analyses can help to define priority groups or areas for intervention one can also look further into the pattern of the descriptive analysis. One can look at the distribution of variables that should follow a normal pattern discrepancies can be used to indicate bias in selection procedures or abnormal circumstances.

The division and graphing of the sample measured into different age groups forms a so - called age - pyramid; usually these age groups are further divided by sex. A comparison of the age - pyramid of the sample and the expected age - pyramid may show differences. These differences can be due to bias in the selection procedure when choosing a sample, or they can be real, indicating excess mortality in certain vulnerable age - groups.

Often, information on age is not available; height/length can then be used as a

proxy for age. Plotting the distribution of height by sex will give the same kind of information as an age pyramid, but its shape will be different because the growth speed decreases in older children. Furthermore, height distribution is more difficult to interpret as stunting affects the proportion of children in height classes as well as age.

To determine the degree of excess mortality, we must make a comparison of the distribution of age or height with the distribution of a reference population of children under five. The <<gaps>> in certain age or height classes indicate an under representation of certain corresponding age groups in the sample.

This may imply a bias in the survey procedure. If the survey methodology was strictly adhered to, this gives an indication of excess mortality in vulnerable age groups in the past. Excess mortality leads to an underestimation of the true malnutrition rate as determined by the survey results.

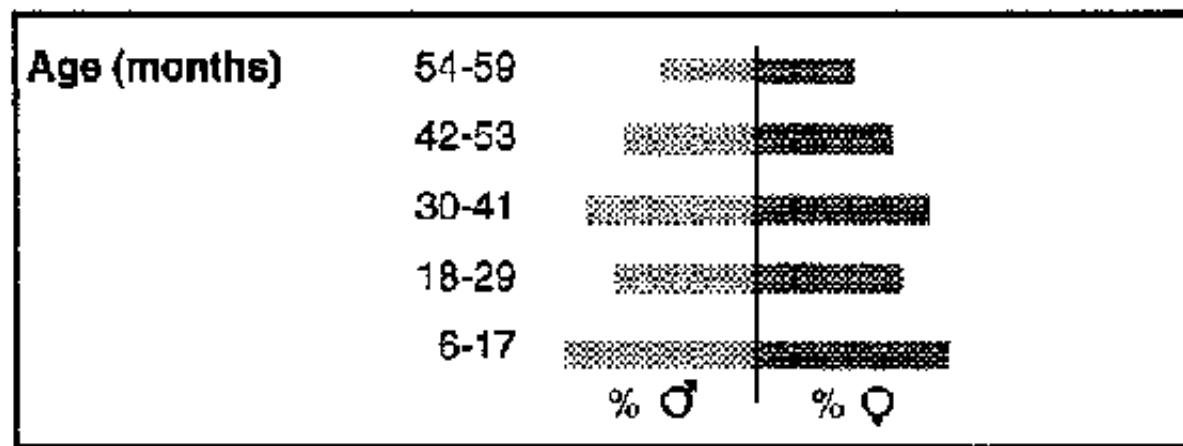

Age + Sex pyramid for Survey sample

FIGURE

- **There are expected to be more children in the younger classes as some children inevitably die over time - therefore we get a slight pyramid shape.**
- **The 54 - 60 month age group has far fewer members than the other age groups however the age group only represents a period of 6 months, whereas all the other groups are for 12 months.**
- **Doubling the number of children in the 54 60 month age group would provide roughly expected numbers.**
- **There is also a lower than expected number of children in the 18 - 29 month age group.**

The survey was implemented well, and there is no reason why we would have selected fewer children in this age group, so we conclude that there has been some excess mortality in this age group. It is then necessary to try and investigate why this age group would have suffered greater mortality than other age groups and devise interventions to focus on the identified problems.

Annex 10: Drawing of a random number

A random number is a number chosen from a list of numbers in a way which gives the same chance to each number being selected.

To start with, the interval in which the number should fall is determined. For example, a random number is required to choose the first cluster in a range 0001 to 1342.

This means that a 4 digit number is always required, and must be less than 1342. Several draws may be necessary in order to get a random number to fall in the interval.

RANDOM NUMBER TABLE

A table as shown on the next page can be used.

- 1st step: the direction for reading the table must be chosen first. A random number table can be read in any direction: from top to bottom, from bottom to top, from left to right or from right to left.
- 2nd step: the required number of digits is determined according to the range of the required value. Hence in order to draw a random number falling into a 0001 - 1342 range, 4 digits are necessary.
- 3rd step: a pen is randomly pointed anywhere on the table. The pen is then moved according to the reading direction chosen to read the first 4 digit number. If it falls within the set interval, this number is kept.
- 4th step: if the number falls outside the interval, the first 3 steps are

4th step.

repeated until an eligible number is drawn.

BANK NOTE TECHNIQUE

If a random number table is not available, the serial number written on a bank note can be used.

1st step: a direction for reading the number is chosen. From left to right or from right to left.

2nd step: the number of digits requested is determined according to the range needed. For example to draw a number falling in the range 01 - 13 a 2 digit number is required.

3rd step: the necessary number of digits is read on the bank note in the chosen direction. If this number falls outside the interval, another bank note should be used for a new draw.

RANDOM NUMBER TABLE

64612	77930	16137	12927	89071	72799	41537	36124	90640	31518	04234
69066	19304	42047	17246	97332	86300	39716	03893	06408	32722	95956
50198	35604	77895	61965	51935	08141	33438	78595	04092	75339	94273
76696	11509	43552	41494	83724	01956	73796	15758	45947	94634	35234
73812	52071	43503	62873	53324	11284	43196	06348	30008	62652	96747
42295	74036	20944	62432	59331	89684	88553	32377	93850	12728	88238

14980	35863	08297	96342	19765	47025	29892	81190	68117	08072	25200
76350	78339	37630	99947	43448	98453	50938	75554	04195	85207	46888
01581	46405	52673	46305	08896	33547	39933	18768	14469	73646	64526
67238	13884	20162	00006	62569	22205	30546	26072	44837	49459	77149
66570	33762	21469	00192	27172	15397	82047	61497	07638	97270	97467
16557	21230	49179	29167	91844	51602	71808	46604	47827	87184	60373
09219	97504	01797	55465	99417	95123	17753	98301	97544	56741	67069
32243	64753	03363	75921	19893	88730	18290	20197	01643	60201	93416
05689	43380	65162	24128	11352	45001	03769	89504	99057	83249	71827
03807	83301	79068	65814	83865	19277	65548	97374	68215	52775	86357
28225	32562	80331	30146	61413	91111	43080	28520	49848	82813	82698
99646	08072	73891	72968	00857	38170	31209	05309	49248	05801	46112
26756	07050	27234	13452	53824	42573	53428	95469	10667	17704	61872
25235	65105	57132	92464	29317	60554	05727	88036	74389	67967	84032
25686	67440	05561	71819	49575	64287	03165	16939	41780	66882	98455
93590	91113	08489	81654	16286	46749	73217	41065	19390	67245	76632
43592	37138	00819	15070	20945	25408	57957	71599	16271	57901	62239
13093	92291	60465	90318	37897	66912	90283	37008	36988	78760	72384
66398	01315	02014	70305	34941	76583	61435	54541	97455	39820	19615
31762	31972	63353	36644	33992	44364	85710	21443	77930	38707	05182
30127	40804	64291	59007	77904	18339	75234	65215	67092	58440	63631
32105	53327	84967	52173	65105	88585	56590	57180	25674	84454	27915
57981	21947	84104	02266	33572	35803	16381	96110	52509	16649	30468
56126	25952	92400	94553	86271	66806	89957	86934	47075	94908	48846
13086	34316	09176	78732	95563	29286	02657	82883	18857	37822	77486
71463	03840	20296	13460	48767	72046	59749	77656	34051	18836	20336
85318	60674	67335	63363	48527	63227	35832	12923	73892	07336	97539
86510	93235	41827	12682	46588	41684	97946	93028	39020	15613	25316
00429	08471	73469	59309	02463	11443	64722	09558	33674	77649	97972
44234	35790	05005	84160	49944	75396	91726	15803	71185	62484	12823
68214	61165	18316	53169	34626	95181	66040	94358	24165	29731	42510
67481	04603	09947	54714	92137	40843	55749	29288	02595	75059	81300
28517	51704	63433	27444	31297	79344	37425	11817	02456	67834	74526
26333	98900	63415	89408	35714	66024	51997	81400	63751	62700	78373
99423	51007	18950	26065	09718	48619	72845	00315	76284	67907	62181

FIGURE

Annex 11: Standardization of anthropometric measuring techniques

It is essential during the training of enumerators to test that they measure children in a standard and accurate way. The test can be used for assessing the quality of any measurements: weight, height as well as mid - upper arm circumference.

1. Definitions

Accuracy: ability to obtain a measurement which will duplicate as closely as possible the reference value.

Precision: ability to repeat a measurement on the same subject with a minimum variation.

These two abilities are complementary. An enumerator may be precise but not accurate: he finds a wrong value for the measure, but he <<precisely>> finds the same wrong value every time. In the same way, an enumerator may be accurate but not precise, meaning the mean measure on a number of measures is close to the reference measure, but wide variation between measures exists.

2. Principle

The standardization test consists of repeating a measure twice on 10 different children, with a time interval between measures on the same child. The amplitude of the variation between repeated measures is calculated to assess precision, and the mean measure is calculated to assess accuracy. Each enumerator is then given some sort of a score of competence in performing measures. Misunderstanding and measuring errors can then be corrected during the training process.

3. Practical organization of the test

The test is carried out during the training process. Ten children aged 6 to 59 months are gathered in a room where the test will be performed. For example, if the measure of height/length is assessed, each enumerator performs the measure and records it for each child on a form. A second series of measures is performed and the enumerators once again record their measures, but on a different form. The supervisor performs the measure as well in order to obtain the reference measures, assuming he is the most precise and accurate measurer available.

4. Analysis

For each enumerator and for the supervisor, the following steps are followed:

Step 1: results of the two measures for each child are entered in column a and b. In order to facilitate the calculations, the height and mid - upper arm circumference are entered in millimeters and the weight in 100 grams.

Step 2: column d is the difference between the two measures: $d = a - b$.

Step 3: in the column labelled d^2 the value of d is squared: $d^2 = (a - b)^2$.

Step 4: in the column labelled <<sign>>, the number of occurrence of the most frequent sign in column <<d>> is entered. For example 7 is entered if there are 7 + signs and 3 - signs.

Step 5: column <<s>> is the sum of column a + column b: $s = a + b$.

These first 5 steps are common to the supervisor and the enumerators. The following 4 steps are only carried out for the enumerators since the test is meant to compare measures of the enumerators to those of the supervisor.

Collecting form for the supervisor

Child N ^o	Supervisor		d (A-B)	d ² (A-B) ²	Sign	S (A+B)
	A 1 st measure	B 2 nd measure				
1	828	822	+ 6	36	+	1650
2	838	846	- 8	64	-	1684
3	860	856	+ 4	16	+	1716
4	862	860	+ 2	4	+	1722
5	820	820	0	0		1640
6	856	854	+ 2	4	+	1710
7	823	824	- 1	1	-	1647
8	876	876	0	0		1752
9	801	806	- 5	25	-	1607
10	853	865	- 12	144	-	1718
			-12	$\Sigma d^2 = 294$	4/8	

FIGURE

Step 6: the column S of the supervisor is added to each of the enumerator's forms.

Step 7: the difference between the s of the enumerators and the S of the supervisor is entered in column D.

Step 8: this difference is squared and entered in the column labelled D². D² =

$$(s - S)^2.$$

Step 9: the greatest number of identical signs (+ or - but the largest) is entered in the column labelled sign.

Collecting forms for the enumerators

Child N ^o	Enumerator X		d (a-b)	d ² (a-b) ²	Sign	Enumerator		Supervisor		Sign
	a 1 st measure	b 2 nd measure				s (a+b)	S (A+B)	D (s-S)	D ² (s-S) ²	
1	842	837	+ 5	25	+	1679	1650	+29	841	+
2	861	854	+ 7	49	+	1715	1681	+34	1156	+
3	862	858	+ 4	16	+	1720	1716	+ 4	16	+
4	875	855	+10	100	+	1740	1722	-18	324	+
5	826	827	- 1	1	-	1653	1640	-13	169	+
6	864	860	+ 4	16	+	1724	1710	-14	196	+
7	820	835	-15	225	-	1655	1647	- 8	64	+
8	884	832	+ 2	4	+	1766	1752	-14	196	+
9	820	815	+ 5	25	+	1635	1607	-28	784	+
10	866	870	- 4	16	-	1735	1718	-18	324	+
+17 $\sum d^2 = 477$ 7/10						+177 $\sum D^2 = 3875$ 10/10				

FIGURE

5. Interpretation

A summary form is established. In this form, the sum of the column d² and D² is calculated: sum(d²) and sum(D²).

sum(d^2) reflects the precision. It represents the sum of the squares of difference between 2 measures on the same child. The acceptable value for the sum(d^2) of an enumerator is equal to twice the value of the sum(d^2) of the supervisor. The sum(d^2) of the supervisor is not zero. One component of the lack of precision is related to the equipment used to perform the measures, and that is why the reference value is calculated from the <<performance>> of the supervisor.

sum(D^2) measures the accuracy. It is the sum of the squares of difference between the sum of the 2 measures on the same child between the supervisor and the enumerator. The acceptable value for the sum(D^2) is fixed at three times the sum(d^2) of the supervisor.

Analysis of the signs allows us to assess whether the lack of precision or accuracy is always in the same direction. For example, an enumerator overestimating the height of a child will have most of the signs for precision as positive (i.e. case of the enumerator No 5 in our example). Such a systematic error can be quantified. Its value is sum($/20$) (2 times 10 measures = 20 measures), being 8.9 millimeters in our example.

Summary sheet, for assessing the measure of the height

Enumerators	Σd^2	Signs	ΣD^2	Signs	Observations
Supervisor	294	4/8			Σd^2 the smallest. Best precision
Limit values	588		882		
Enum. N°1	324	6/9	524	7/10	$\Sigma d^2 < 588$. Satisfactory precision $\Sigma D^2 < 882$. Satisfactory accuracy
Enum. N°2	431	6/10	1,195	8/9	$\Sigma d^2 < 588$. Satisfactory precision $\Sigma D^2 > 882$. Lack of accuracy
Enum. N°3	774	5/10	1,024	7/10	Lack of precision and accuracy
Enum. N°4	893	5/9	3,655	9/10	Lack of precision and accuracy
Enum. N°5	477	7/10	3,875	10/10	Satisfactory precision. Lack of accuracy. Systematic error, 10/10 for the signs
Enum. N°6	1,278	7/10	1 040	6/10	Lack of precision and accuracy

These standardization tests allow an objective evaluation of the performance of the enumerators.

FIGURE

Annex 12: Data collection forms

Annex 12: Data collection forms

INDIVIDUAL DATA FORM

Cluster N° : Village/Section :

Name of block : Household number :

Team number : Supervisor name :

Child's number in the cluster :

Name of the child :

Father's name :

Date of the first visit : ... / ... / ... Time of the visit : ... : ...

Child : Present :

Absent :

Refusing :

reason :

Date of the second visit : ... / ... / ... Time of the visit : ... : ...

Child : Present :

Absent :

Refusing :

reason :

Birth date : ^D / ^M / ^Y

or

Age in months : months

Sex : M / F

Weight : , Kg

Height : , Cm Measured : lying

standing

Oedema : Y/N

The definition of variables can be found in the «surveyor manual»
attached to the cluster collecting form.

FIGURE

CLUSTER DATA FORM

Cluster N° :

Village/section :

Date of the survey : ... / ... / ...

Team number :

First birth date to be included : ... / ... / ...

Last birth date to be included : ... / ... / ... *

Birth date before which children should be measured standing : ... / ... / ...

N°	Birth date	Age in month **	Sex 1 = M 2 = F	Weight in KG and g	Height in cm and mm	Oedema 1=yes 2=no	Var 1 ***	Var 2	Var 3	Var 4	Var 5
1	//			.	.						
2	//			.	.						
3	//			.	.						
4	//			.	.						
5	//			.	.						
6	//			.	.						
7	//			.	.						
8	//			.	.						
9	//			.	.						
10	//			.	.						
11	//			.	.						
12	//			.	.						
13	//			.	.						
14	//			.	.						
15	//			.	.						
16	//			.	.						
17	//			.	.						
18	//			.	.						
19	//			.	.						
20	//			.	.						
21	//			.	.						
22	//			.	.						

23	///								
24	///								

* Only children born between these dates are included in the survey.

** Estimate the age if birth date is unknown

*** Enter any additional variables.

FIGURE

SURVEYOR MANUAL

An individual data form is filled in for each child surveyed. When a cluster has been completed, and before leaving the section, the supervisor and the enumerators fill in the cluster data form. At this stage it is still possible to correct any mistakes and check validity criteria. Any mistake should be corrected by going back to the child.

The cluster data form is attached to the surveyor manual, on which all questions to be asked are written in the local tongue. Such a manual can be designed for systematic sample surveys as well.

HOW TO FILL IN THE CLUSTER DATA FORM

A sheet mentioning all instructions is attached to the cluster data form. It is the reference for the enumerators when performing the measurements in the field.

- Cluster number / Allege / section**

A list of all the clusters with their names and numbers is distributed. This cluster

number is the one entered on the collecting form.

- **Date of the survey**

The date of the day when the data was collected is recorded.

- **First birth date included in the survey**

This box is filled in on the day of the survey by the team supervisor. This date is the date of the day after the survey, but 5 years before. For a survey taking place on the 30/01/1991, the first birth date for inclusion in the survey is the 31/01/1986.

- **Last birth date of inclusion in the survey**

This date is the date of the survey minus 6 months. For example if the survey takes place on the 30/01/1991, the last birth date of inclusion in the survey will be the 30/07/1990.

- **Birth date before which children are measured standing**

This is the date of the survey minus two years. For a survey taking place on the 30/01/1991, the first birth date before which children should be measured standing would be the 30/01/1989.

Annex 13: W/H Reference tables

Annex 13: W/H Reference tables

1 2 3 4 5 6 7 8 9 10 11 12 13 14 15 16 17 18 19 20 21 22 23 24 25 26 27 28 29 30 31 32 33 34 35 36 37 38 39 40 41 42 43 44 45 46 47 48 49 50 51 52 53 54 55 56 57 58 59 60 61 62 63 64 65 66 67 68 69 70 71 72 73 74 75 76 77 78 79 80 81 82 83 84 85 86 87 88 89 90 91 92 93 94 95 96 97 98 99 100

**I. NCHS/CDC/WHO sex combined references (1982), Expressed as Percentage of
the Median
Length assessed lying up to 84.5cm**

Length cm.	Median kg	85% kg	80% kg	75% kg	70% kg	60% kg	Length cm.	Median kg	85% kg	80% kg	75% kg	70% kg	60% kg
49.0	3.2	2.7	2.6	2.4	2.3	1.92	67.0	7.5	6.5	6.1	5.7	5.3	4.56
49.5	3.3	2.8	2.6	2.5	2.3		67.5	7.8	6.6	6.2	5.8	5.4	
50.0	3.4	2.9	2.7	2.5	2.4	2.04	68.0	7.9	6.7	6.3	5.9	5.5	4.74
50.5	3.4	2.9	2.7	2.6	2.4		68.5	8.0	6.8	6.4	6.0	5.6	
51.0	3.5	3.0	2.8	2.6	2.5	2.1	69.0	8.2	7.0	6.6	6.1	5.7	4.92
51.5	3.6	3.1	2.9	2.7	2.5		69.5	8.3	7.1	6.7	6.2	5.8	
52.0	3.7	3.1	3.0	2.8	2.6	2.22	70.0	8.5	7.2	6.8	6.3	5.9	5.1
52.5	3.8	3.2	3.0	2.8	2.6		70.5	8.6	7.3	6.9	6.4	6.0	
53.0	3.9	3.3	3.1	2.9	2.7	2.34	71.0	8.7	7.4	7.0	6.5	6.1	5.22
53.5	4.0	3.4	3.2	3.0	2.8		71.5	8.9	7.5	7.1	6.6	6.2	
54.0	4.1	3.5	3.3	3.1	2.9	2.46	72.0	9.0	7.6	7.2	6.7	6.3	5.4
54.5	4.2	3.6	3.4	3.2	2.9		72.5	9.1	7.7	7.3	6.8	6.4	
55.0	4.3	3.7	3.5	3.2	3.0	2.58	73.0	9.2	7.9	7.4	6.9	6.5	5.52
55.5	4.4	3.8	3.5	3.3	3.1		73.5	9.4	8.0	7.5	7.0	6.5	
56.0	4.6	3.9	3.6	3.4	3.2	2.76	74.0	9.5	8.1	7.6	7.1	6.6	5.7
56.5	4.7	4.0	3.7	3.5	3.3		74.5	9.6	8.2	7.7	7.2	6.7	
57.0	4.8	4.1	3.8	3.6	3.4	2.88	75.0	9.7	8.2	7.8	7.3	6.8	5.82
57.5	4.9	4.2	3.9	3.7	3.4		75.5	9.8	8.3	7.9	7.4	6.9	
58.0	5.1	4.3	4.0	3.8	3.5	3.06	76.0	9.9	8.4	7.9	7.4	6.9	5.94
58.5	5.2	4.4	4.2	3.9	3.6		76.5	10.0	8.5	8.0	7.5	7.0	
59.0	5.3	4.5	4.3	4.0	3.7	3.18	77.0	10.1	8.6	8.1	7.6	7.1	6.06
59.5	5.5	4.6	4.4	4.1	3.8		77.5	10.2	8.7	8.2	7.7	7.2	
60.0	5.6	4.8	4.5	4.2	3.9	3.36	78.0	10.4	8.8	8.3	7.8	7.2	6.24
60.5	5.7	4.9	4.6	4.3	4.0		78.5	10.5	8.9	8.4	7.8	7.3	
61.0	5.9	5.0	4.7	4.4	4.1	3.54	79.0	10.6	9.0	8.4	7.9	7.4	6.36
61.5	6.0	5.1	4.8	4.5	4.2		79.5	10.7	9.1	8.5	8.0	7.5	
62.0	6.2	5.2	4.9	4.6	4.3	3.72	80.0	10.8	9.1	8.6	8.1	7.5	6.48
62.5	6.3	5.4	5.0	4.7	4.4		80.5	10.9	9.2	8.7	8.1	7.6	
63.0	6.5	5.5	5.2	4.8	4.5	3.9	81.0	11.0	9.3	8.8	8.2	7.7	6.6
63.5	6.6	5.5	5.3	5.0	4.6		81.5	11.1	9.4	8.8	8.3	7.7	
64.0	6.7	5.7	5.4	5.1	4.7	4.14	82.0	11.2	9.5	8.9	8.4	7.8	6.72
64.5	6.9	5.9	5.5	5.2	4.8		82.5	11.3	9.5	9.0	8.4	7.9	
65.0	7.0	6.0	5.6	5.3	4.9	4.2	83.0	11.4	9.6	9.1	8.5	7.9	6.84
65.5	7.2	6.1	5.7	5.4	5.0		83.5	11.5	9.7	9.2	8.6	8.0	
66.0	7.3	6.2	5.9	5.5	5.1	4.38	84.0	11.5	9.8	9.2	8.7	8.1	6.9
66.5	7.5	6.4	6.0	5.6	5.2		84.5	11.6	9.9	9.3	8.7	8.2	

FIGURE

Height assessed standing from 85.0cm

Length cm.	Median kg	85% kg	80% kg	75% kg	70% kg	60% kg	Length cm.	Median kg	85% kg	80% kg	75% kg	70% kg	60% kg
85.0	17.0	11.2	9.5	9.0	8.4	7.2	107.5	17.7	15.0	14.1	13.3	12.4	10.6
85.5	12.1	11.3	9.7	9.1	8.5	7.3	108.0	17.8	15.2	14.3	13.4	12.5	10.7
86.0	12.2	11.4	9.8	9.2	8.6	7.3	108.5	18.0	15.3	14.4	13.5	12.6	10.8
86.5	12.3	11.5	9.8	9.2	8.6	7.4	109.0	18.1	15.4	14.5	13.6	12.7	10.9
87.0	12.4	11.6	9.9	9.3	8.7	7.4	109.5	18.3	15.5	14.6	13.7	12.8	11.0
87.5	12.5	11.6	10.0	9.4	8.8	7.5	110.0	18.4	15.7	14.8	13.8	12.9	11.0
88.0	12.6	11.7	10.1	9.5	8.9	7.6	110.5	18.6	15.8	14.9	14.0	13.0	11.2
88.5	12.8	11.8	10.2	9.6	9.0	7.7	111.0	18.8	16.0	15.0	14.1	13.1	11.3
89.0	12.9	11.9	10.3	9.7	9.0	7.7	111.5	18.9	16.1	15.1	14.2	13.3	11.3
89.5	13.0	11.0	10.4	9.7	9.1	7.8	112.0	19.1	16.2	15.3	14.3	13.4	11.5
90.0	13.1	11.1	10.5	9.8	9.2	7.9	112.5	19.3	16.4	15.4	14.4	13.5	11.6
90.5	13.2	11.2	10.6	9.9	9.2	7.9	113.0	19.4	16.5	15.5	14.6	13.6	11.6
91.0	13.3	11.3	10.7	10.0	9.3	8.0	113.5	19.6	16.7	15.7	14.7	13.7	11.8
91.5	13.4	11.4	10.8	10.1	9.4	8.0	114.0	19.8	16.8	15.8	14.8	13.8	11.9
92.0	13.6	11.5	10.8	10.2	9.5	8.2	114.5	19.9	16.9	16.0	15.0	14.0	11.9
92.5	13.7	11.6	10.9	10.3	9.6	8.2	115.0	20.1	17.1	16.1	15.1	14.1	12.1
93.0	13.8	11.7	11.0	10.3	9.7	8.3	115.5	20.3	17.3	16.2	15.2	14.2	12.2
93.5	13.9	11.8	11.1	10.4	9.7	8.3	116.0	20.5	17.4	16.4	15.4	14.3	12.3
94.0	14.0	11.9	11.2	10.5	9.8	8.4	116.5	20.7	17.5	16.5	15.5	14.5	12.4
94.5	14.2	12.0	11.3	10.5	9.9	8.5	117.0	20.8	17.7	16.7	15.6	14.6	12.5
95.0	14.3	12.1	11.4	10.7	10.0	8.6	117.5	21.0	17.9	16.8	15.8	14.7	12.6
95.5	14.4	12.2	11.5	10.8	10.1	8.6	118.0	21.2	18.0	17.0	15.9	14.9	12.7
96.0	14.5	12.4	11.6	10.9	10.2	8.7	118.5	21.4	18.2	17.1	16.1	15.0	12.8
96.5	14.7	12.5	11.7	11.0	10.3	8.8	119.0	21.6	18.4	17.3	16.2	15.1	13.0
97.0	14.8	12.5	11.8	11.1	10.3	8.9	119.5	21.8	18.5	17.4	16.4	15.3	13.1
97.5	14.9	12.7	11.9	11.2	10.4	8.9	120.0	22.0	18.7	17.6	16.5	15.4	13.2
98.0	15.0	12.8	12.0	11.3	10.5	9.0	120.5	22.2	18.9	17.8	16.7	15.5	13.3
98.5	15.2	12.9	12.1	11.4	10.6	9.1	121.0	22.4	19.1	17.9	16.8	15.7	13.4
99.0	15.3	13.0	12.2	11.5	10.7	9.2	121.5	22.6	19.2	18.1	17.0	15.8	13.6
99.5	15.4	13.1	12.3	11.6	10.8	9.2	122.0	22.8	19.4	18.3	17.1	16.0	13.7
100.0	15.6	13.2	12.4	11.7	10.9	9.4	122.5	23.1	19.6	18.4	17.3	16.1	13.9
100.5	15.7	13.3	12.6	11.8	11.0	9.4	123.0	23.3	19.8	18.6	17.5	16.3	14.0
101.0	15.8	13.5	12.7	11.9	11.1	9.5	123.5	23.5	20.0	18.8	17.6	16.5	14.1
101.5	16.0	13.6	12.8	12.0	11.2	9.5	124.0	23.7	20.2	19.0	17.8	16.6	14.2
102.0	16.1	13.7	12.9	12.1	11.3	9.7	124.5	24.0	20.4	19.2	18.0	16.9	14.4
102.5	16.2	13.8	13.0	12.2	11.4	9.7	125.0	24.2	20.6	19.4	18.2	16.9	14.5
103.0	16.4	13.9	13.1	12.3	11.5	9.8	125.5	24.4	20.8	19.6	18.3	17.1	14.6
103.5	16.5	14.0	13.2	12.4	11.6	9.9	126.0	24.7	21.0	19.7	18.5	17.3	14.8
104.0	16.7	14.2	13.3	12.5	11.7	10.0	126.5	24.9	21.2	19.9	18.7	17.5	14.9
104.5	16.8	14.3	13.4	12.6	11.8	10.1	127.0	25.2	21.4	20.1	18.9	17.6	15.1

Nutrition Guidelines (MSF, 1995, 191 p.)

105.0	16.9	14.4	13.6	12.7	11.9	10.1	127.5	25.4	21.6	20.4	19.1	17.8	15.2
105.5	17.1	14.5	13.7	12.8	12.0	10.2	128.0	25.7	21.8	20.6	19.3	18.0	15.4
106.0	17.7	14.6	13.8	12.9	12.1	10.3	128.5	26.0	22.1	20.8	19.5	18.2	15.6
106.5	17.4	14.8	13.9	13.0	12.2	10.4	129.0	26.2	22.3	21.0	19.7	18.4	15.7
107.0	17.5	14.9	14.0	13.1	12.3	10.5	129.5	26.5	22.5	21.2	19.9	18.6	15.9
							130.0	26.5	22.6	21.4	20.1	18.7	16.0

FIGURE

NCHS/CDC sex combined references (1982), expressed as Z-Scores
Length assessed lying up to 84.5cm

Length cm	Median kg	-1.5 Z- Score	-2 Z- Scores	3 Z Scores	4 Z Scores	Length cm	Median kg	-1.5 Z- Score	-2 Z- Scores	3 Z- Scores	4 Z- Scores
50.0	3.4	2.8	2.5	2.2	1.8	68.0	7.0	6.8	6.4	5.7	4.9
50.5	3.4	2.8	2.5	2.2	1.8	68.5	8.0	6.9	6.5	5.8	5.0
51.0	3.5	2.9	2.7	2.3	1.9	69.0	8.2	7.1	6.7	5.9	5.1
51.5	3.5	3.0	2.7	2.3	1.9	69.5	8.3	7.2	6.8	6.0	5.2
52.0	3.7	3.1	2.8	2.4	1.9	70.0	8.5	7.3	6.9	6.1	5.4
52.5	3.8	3.1	2.9	2.4	2.0	70.5	8.6	7.5	7.0	6.3	5.5
53.0	3.9	3.2	2.9	2.5	2.0	71.0	8.7	7.6	7.2	6.4	5.6
53.5	4.0	3.3	3.0	2.5	2.1	71.5	8.9	7.7	7.3	6.5	5.7
54.0	4.1	3.4	3.1	2.6	2.1	72.0	9.0	7.8	7.4	6.6	5.8
54.5	4.2	3.5	3.2	2.7	2.2	72.5	9.1	7.9	7.5	6.7	5.9
55.0	4.3	3.6	3.3	2.8	2.2	73.0	9.2	8.0	7.6	6.8	6.0
55.5	4.4	3.6	3.4	2.8	2.3	73.5	9.4	8.2	7.7	6.9	6.4
56.0	4.6	3.8	3.5	2.9	2.4	74.0	9.5	8.3	7.8	7.0	6.2
56.5	4.7	3.9	3.6	3.0	2.5	74.5	9.6	8.4	7.9	7.1	6.3
57.0	4.8	4.0	3.7	3.1	2.5	75.0	9.7	8.5	8.1	7.2	6.4
57.5	4.9	4.1	3.8	3.2	2.6	75.5	9.8	8.6	8.2	7.3	6.5
58.0	5.1	4.2	3.9	3.3	2.7	76.0	9.9	8.7	8.3	7.4	6.6
58.5	5.2	4.3	4.0	3.4	2.8	76.5	10.0	8.8	8.4	7.5	6.7
59.0	5.3	4.4	4.1	3.5	2.9	77.0	10.1	8.9	8.5	7.6	6.8
59.5	5.5	4.6	4.2	3.6	3.0	77.5	10.2	9.0	8.6	7.7	6.9
60.0	5.6	4.7	4.3	3.7	3.1	78.0	10.4	9.1	8.6	7.8	6.9

Nutrition Guidelines (MSF, 1995, 191 p.)

60.5	5.7	4.8	4.5	3.8	3.2	78.5	10.5	9.2	8.7	7.9	7.0
61.0	5.9	4.9	4.6	3.9	3.3	79.0	10.6	9.3	8.8	8.0	7.1
61.5	6.0	5.1	4.7	4.1	3.4	79.5	10.7	9.4	8.9	8.1	7.2
62.0	6.2	5.2	4.8	4.2	3.5	80.0	10.8	9.5	9.0	8.1	7.3
62.5	6.3	5.3	5.0	4.3	3.6	80.5	10.9	9.6	9.1	8.2	7.4
63.0	6.5	5.5	5.1	4.4	3.7	81.0	11.0	9.7	9.2	8.3	7.4
63.5	6.6	5.6	5.2	4.5	3.9	81.5	11.1	9.8	9.3	8.4	7.5
64.0	6.7	5.7	5.4	4.7	4.0	82.0	11.2	9.9	9.4	8.5	7.6
64.5	6.9	5.9	5.5	4.8	4.1	82.5	11.3	10.0	9.5	8.6	7.7
65.0	7.0	6.0	5.6	4.9	4.2	83.0	11.4	10.1	9.6	8.7	7.8
65.5	7.2	6.1	5.8	5.0	4.3	83.5	11.5	10.1	9.6	8.7	7.8
66.0	7.3	6.3	5.9	5.2	4.4	84.0	11.5	10.2	9.7	8.8	7.9
66.5	7.5	6.4	6.0	5.3	4.6	84.5	11.6	10.3	9.8	8.9	8.0
67.0	7.6	6.5	6.1	5.4	4.7						
67.5	7.8	6.7	6.3	5.5	4.8						

FIGURE

Height assessed standing from 85.0cm

Length cm	Median kg	-1.5 Z- Score	-2 Z- Scores	-3 Z- Scores	-4 Z- Scores	Length cm	Median kg	-1.5 Z- Score	-2 Z- Scores	-3 Z- Scores	-4 Z- Scores
85.0	12.0	10.4	9.8	9.7	7.7	106.0	17.8	15.5	14.7	13.2	11.6
85.5	12.1	10.5	9.9	9.8	7.7	106.5	18.0	15.7	14.8	13.3	11.7
86.0	12.2	10.6	10.0	9.9	7.8	107.0	18.1	15.8	15.0	13.4	11.8
86.5	12.3	10.7	10.1	10.0	7.9	107.5	18.3	15.9	15.1	13.5	11.9
87.0	12.4	10.8	10.2	10.1	8.0	110.0	18.4	16.0	15.2	13.6	12.0
87.5	12.5	10.9	10.3	10.2	8.1	110.5	18.6	16.2	15.4	13.8	12.2
88.0	12.6	11.0	10.4	10.3	8.2	111.0	18.8	16.4	15.5	13.9	12.3
88.5	12.8	11.1	10.5	10.4	8.2	111.5	18.9	16.5	15.7	14.0	12.4
89.0	12.9	11.2	10.6	10.5	8.3	112.0	19.1	16.7	15.8	14.2	12.5
89.5	13.0	11.3	10.7	10.6	8.4	112.5	19.3	16.8	15.9	14.3	12.6
90.0	13.1	11.4	10.8	10.7	8.5	113.0	19.4	16.9	16.1	14.4	12.8
90.5	13.2	11.5	10.9	10.8	8.6	113.5	19.6	17.1	16.2	14.6	12.9
91.0	13.3	11.6	11.0	10.9	8.6	114.0	19.8	17.3	16.4	14.7	13.0
91.5	13.4	11.7	11.1	11.0	8.7	114.5	19.9	17.4	16.5	14.8	13.1
92.0	13.6	11.8	11.2	11.0	8.8	115.0	20.1	17.6	16.7	15.0	13.3
92.5	13.7	11.9	11.3	11.1	8.9	115.5	20.3	17.7	16.8	15.1	13.4
93.0	13.8	12.0	11.4	11.2	9.0	116.0	20.5	17.9	17.0	15.3	13.5
93.5	13.9	12.1	11.5	11.3	9.0	116.5	20.7	18.1	17.2	15.4	13.7
94.0	14.0	12.2	11.6	11.4	9.1	117.0	20.8	18.2	17.3	15.6	13.8
94.5	14.2	12.3	11.7	11.5	9.2	117.5	21.0	18.4	17.5	15.7	13.9
95.0	14.3	12.4	11.8	11.6	9.3	118.0	21.2	18.5	17.6	15.8	14.1

Nutrition Guidelines (MSF, 1995, 191 p.)

95.5	14.4	12.5	11.9	10.6	9.1	118.5	21.4	18.7	17.8	16.0	14.2
96.0	14.5	12.6	12.0	10.7	9.4	119.0	21.6	18.9	18.0	16.2	14.3
96.5	14.7	12.8	12.1	10.8	9.5	119.5	21.8	19.1	18.1	16.3	14.5
97.0	14.8	12.9	12.2	10.9	9.6	120.0	22.0	19.3	18.3	16.5	14.6
97.5	14.9	13.0	12.3	11.0	9.7	120.5	22.2	19.4	18.5	16.6	14.8
98.0	15.0	13.1	12.4	11.1	9.8	121.0	22.4	19.6	18.7	16.8	14.9
98.5	15.2	13.2	12.5	11.2	9.8	121.5	22.6	19.8	18.8	16.9	15.0
99.0	15.3	13.3	12.6	11.3	9.9	122.0	22.8	20.0	19.0	17.1	15.2
99.5	15.4	13.4	12.7	11.4	10.0	122.5	23.1	20.2	19.2	17.3	15.3
100.0	15.6	13.6	12.8	11.5	10.1	123.0	23.3	20.4	19.4	17.4	15.5
100.5	15.7	13.7	12.9	11.6	10.2	123.5	23.5	20.5	19.6	17.6	15.6
101.0	15.8	13.8	13.0	11.7	10.3	124.0	23.7	20.7	19.7	17.7	15.7
101.5	16.0	13.9	13.2	11.8	10.4	124.5	24.0	21.0	19.9	17.9	15.9
102.0	16.1	14.0	13.3	11.9	10.4	125.0	24.2	21.2	20.1	18.1	16.0
102.5	16.2	14.1	13.4	12.0	10.5	125.5	24.4	21.3	20.3	18.2	16.2
103.0	16.4	14.3	13.5	12.1	10.6	126.0	24.7	21.6	20.5	18.4	16.3
103.5	16.5	14.4	13.6	12.2	10.5	126.5	24.9	21.8	20.7	18.5	16.4
104.0	16.7	14.5	13.7	12.3	10.8	127.0	25.2	22.0	20.9	18.7	16.6
104.5	16.8	14.6	13.8	12.4	10.9	127.5	25.4	22.2	21.1	18.9	16.7
105.0	16.9	14.7	14.0	12.5	11.0	128.0	25.7	22.4	21.3	19.1	16.9
105.5	17.1	14.8	14.1	12.6	11.1	128.5	26.0	22.6	21.5	19.2	17.0
106.0	17.2	15.0	14.2	12.7	11.2	129.0	26.2	22.8	21.7	19.4	17.1
106.5	17.4	15.1	14.3	12.8	11.3	129.5	26.5	23.1	21.9	19.6	17.3
107.0	17.5	15.2	14.5	12.9	11.4	130.0	26.8	23.3	22.1	19.7	17.4
107.5	17.7	15.4	14.6	13.0	11.5						

FIGURE

Annex 14: Selection of food items for selective feeding programmes

There might be a need to purchase food items from own funds. If time allows it, consult head quarters and ask for a quotation. If buying locally, be prepared to check on quality specifications.

1. Blended foods Check for:

- nutritional value (energy minimum 350 Kcal/100g; fat min. 20% of energy, protein around 15g per 100g, micronutrients)

- **bacterial safety and hygiene;**
- **necessary cooking time (pre - cooked or not) and other utilization information;**
- **shelf - life/Expiry date;**
- **packaging and labelling.**

The digestibility, taste, energy density and the shelf - life will depend on the heat treatment type that has been used; extrusion cooking is to be preferred over roasting.

Food items for feeding programmes have to fulfil certain specific criteria. One should not accept food donations indiscriminately. The use of poor quality or inappropriate food stuffs for the treatment of acutely malnourished children and/or adults can be dangerous.

Dependency on several donors might result in the supply/use of a variety of food items over time. This can be very confusing for the staff or mothers, who have to change recipes and to adapt to new diet. Try to classify these different items in similar categories. Take into account: energy density (Kcal/100g), fat and protein content, palatability and acceptability, digestibility.

2. Dried Milk: quality control

Check for:

a. Consistency: if the milk powder forms lumps, the humidity is too high and storage conditions must be checked. We can not be sure that the milk powder has not developed bacterial or fungal infection. The milk powder may no longer be safe and it may be necessary to discard it.

b. Colour: Dried milk is normally light yellow. If it is brownish, there has been a chemical reaction of the sugar and protein. The milk powder must be discarded, because the quality of the protein has been affected.

c. Smell: If the milk smells rancid, the milk must be discarded.

Dried Skimmed milk is preferred over full milk; the higher fat content of full milk makes it less digestible, can provoke diarrhoea, and its shelf - life is limited.

Dried Skim Milk should be fortified with vitamin A (5,000 to 10,000 IU/100g and, D3, 500 to 1,000 IU /100g). If it is not indicated on the bag, consider the milk powder not fortified. Furthermore, the vitamin A is broken down on storage: after 6 months, vitamin A content can be considered negligible. In these cases milk powder can only be used in combination with prophylactic vitamin A distributions.

Policy of the UNHCR related to the acceptance, distribution and use of milk products in feeding programmes in refugees settings

1. UNHCR will accept, supply and distribute donations of milk products only if they can be used under strict control and in hygienic conditions, e.g. in a supervised environment for on - the - spot consumption.

2. UNHCR will accept, supply and distribute milk products only when received in a dry form. UNHCR will not accept liquid or semi - liquid products including evaporated or condensed milk.

3. UNHCR will accept, supply and distribute dried skim milk (DSM) only if it has been fortified with vitamin A.

- 4. UNHCR supports the principle that in general ration programmes protein sources such as pulses, meat or fish are preferred to dried skim milk. UNHCR notes that DSM pre - mixed centrally with cereal flour and sugar is useful for feeding young children especially if prepared with oil.**
- 5. UNHCR will advocate the distribution of dried skimmed milk in a take - away form, only if it has been previously mixed with a suitable cereal flour, and only when culturally acceptable. The sole exception to this may be where milk forms an essential part of the traditional diet (e.g. nomadic population) and can be used safely.**
- 6. UNHCR will support the policy of the World Health Organization concerning safe and appropriate infant and young child feeding, in particular by protecting, promoting and supporting breast - feeding and encouraging the timely and correct use of complementary foods in refugee settings.**
- 7. UNHCR will discourage the distribution and use of breast - milk substitutes in refugee settings. When such substitutes are absolutely necessary, they will be provided together with clear instructions for safe mixing, and for feeding with a cup and a spoon.**
- 8. UNHCR will take all possible steps to actively discourage the distribution and use of infant - feeding bottles and artificial teats in refugee settings.**
- 9. UNHCR will advocate that when donations of DSM are supplied to refugee programmes, the specific donors will be approached for cash contributions to be specially earmarked for operational costs of projects to ensure the safe use of this**

commodity.

Paper prepared by UNHCR, 17/8/93: Programme coordination and Budget section, Food and Statistical Unit.

Annex 15: Oral rehydration for severely malnourished children

Normal ORS treatment, as recommended by the WHO, should be used for the treatment of dehydration in mildly and moderately malnourished children. Severely malnourished children suffer from an imbalance of electrolytes that makes the use of normal ORS dangerous for treating dehydrated children with severe malnutrition, except from when they suffer from cholera or severe diarrhoea when normal ORS should also be used.

In the treatment of dehydration for severely malnourished children, it is necessary to reduce the sodium content of the traditional ORS formula and increase the potassium content.

Special ORS sachets are currently available (from Nutriset) for the treatment of dehydration in severely malnourished children. These sachets have a re - adjusted formula. If the special ORS sachets are not available in the field it is necessary to dilute normal ORS to half strength and add 25g of sugar per litre and 2g of potassium (KCl) per litre.

Water	10 litres
ORS (1 litre sachets)	5 packets
Sugar	250g
KCl	20g

FIGURE

Unlike the use of normal ORS, we do not give a malnourished child a large initial dose of ORS to begin treatment, as this can overload the circulatory system. Thus, we give the required amount (5 - 15 ml/Kg/hour) slowly over the whole treatment period until signs of dehydration have disappeared.

Only treat dehydration intravenously in cases of severe shock and with great caution.

Annex 16a: Preparation of High Energy Milk

High energy milk is prepared in order to provide 100 Kcal/100 ml with 2.8g of protein/100 ml.

Average ration per child per day:1.8 litre of HEM.

1. Recipe based on DSM (Dried Skimmed Milk)

1. Recipe based on DSM (Dried Skimmed Milk)

Preparation for 1 litre of HEM

ITEM	Weight (g)	Kcal	Protein (g)
DSM	80	286	28.8
OIL	60	531	0
SUGAR	50	200	0
WATER	add water to make 1 litre	0	0
TOTAL	1 LITRE	1019	28.8

2. Recipe based on FCM (Full cream milk)

Preparation for 1 litre of HEM

ITEM	Weight (g)	Kcal	Protein (g)
FCM	110	550	28.6
OIL	30	266	0
SUGAR	50	200	0
WATER	add water to make 1 litre	0	0
TOTAL	1 LITRE	1016	28.6

FIGURE

The premix (milk powder, sugar and oil) should be prepared in advance. Always weigh the ingredients, do not use quantities measured by volume. The premix can be kept for about one week, provided that it is stored in a dry place.

The milk should be made up just before distribution. The water used should be boiled cold water. Once made up, the high energy milk should not be kept for more

than 2 hours and should be protected from flies.

Annex 16b: Recipes for porridge for use in therapeutic and wet supplementary feeding programmes

The porridge can be prepared for children in Therapeutic feeding as well for children in wet Supplementary feeding centres.

Usually, a porridge will provide around 150 Kcal/100 ml and around 4g of protein/100 ml.

1. Recipe one: Maize flour + DSM based porridge

1. Recipe one : Maize flour + DSM based porridge*Preparation for 1 meal for 1 child.*

ITEM	Weight (g)	Kcal	Protein (g)
MAIZE	60	215	6
DSM	45	160	16
OIL	30	265	0
SUGAR	15	60	0
WATER	± 400	0	0
TOTAL	550	700	22

2. Recipe two : CSB based porridge*Preparation for 1 meal for 1 child*

ITEM	Weight (g)	Kcal	Protein (g)
CSB	100	580	18
OIL	30	265	0
SUGAR	20	80	0
WATER	± 300	0	0
TOTAL	450	725	18

FIGURE**PREPARATION:**

Always prepare a sample and taste the porridge before distribution. The porridge should be semi - liquid.

Generally the preparation is:

Add 1 volume of premix to 2 - 3 volumes of water

Boil for 10 - 15 minutes

Cooked porridge should not be kept for more than 2 hours.

Annex 16c: Recipes for premix for dry ration supplementary feeding programmes

Each ration should provide at least 1000 Kcal per child per day and 30 - 45g of protein.

Examples of recipes of premix for a week for one child

FOOD ITEMS	Weekly quantity (g)	Kcals/day	Protein g/day
WSB	980	518	28
DSM	350	180	18
OIL	350	450	0
SUGAR	210	120	0
TOTAL	1,900	1,268	46
CSB	1,600	869	41
OIL	200	257	0
SUGAR	200	114	0
TOTAL	2,000	1,240	41
MAIZE	720	360	10
DSM	540	277	27
OIL	360	469	0
SUGAR	180	103	0
TOTAL	1,800	1,209	37
SORGHUM	1,100	526	17
LENTILS	500	239	16
OIL	300	386	0
SUGAR	100	57	0
TOTAL	2,000	1,208	33

FIGURE

The premix should be prepared before distribution. Always prepare a sample and

taste the porridge before distribution. The porridge should be semi - liquid when prepared.

The premix can be kept at home for about one week, it is recommended to keep it covered and in a dry and clean place.

Preparation of dry rations at home:

- **Add 1 volume of premix to 2 - 3 volumes of water.**
- **Boil for 10 - 15 minutes (more for receipes 3 and 4).**

Cooked porridge should not be kept for more than 2 hours.

Annex 16d : Indicative table for the preparation of Premix and reconstitution of High Energy Milk (HEM)

100ml of HEM – 100KCal and 2.9g of proteins

DSM (kg)	Sugar (kg)	Oil (kg)	Premix (kg)	Approximative Quantity of Water (kg or litre)	Final Volume of HEM (litres)
0.08	0.05	0.06	0.190	± 0.800	1
0.4	0.25	0.3	0.950	4.05	5
0.8	0.5	0.6	1.9	8.1	10
1.6	1	1.2	3.8	16.2	20
2.4	1.5	1.8	5.7	24.3	30
3.2	2	2.4	7.6	32.4	40

Nutrition Guidelines (MSF, 1995, 191 p.)

4	2.5	3	9.5	40.5	50
4.8	3	3.6	11.4	48.6	60
5.6	3.5	4.2	13.3	56.7	70
6.4	4	4.8	15.8	64.8	80
7.2	4.5	5.4	17.1	72.9	90
8	5	6	19	81	100
16	10	12	38	162	200
24	15	18	57	243	300
32	20	24	76	324	400
40	25	30	95	405	500

BE CAREFUL :
 Always check the quantity of water in order to obtain the exact final volume indicated.

FIGURE

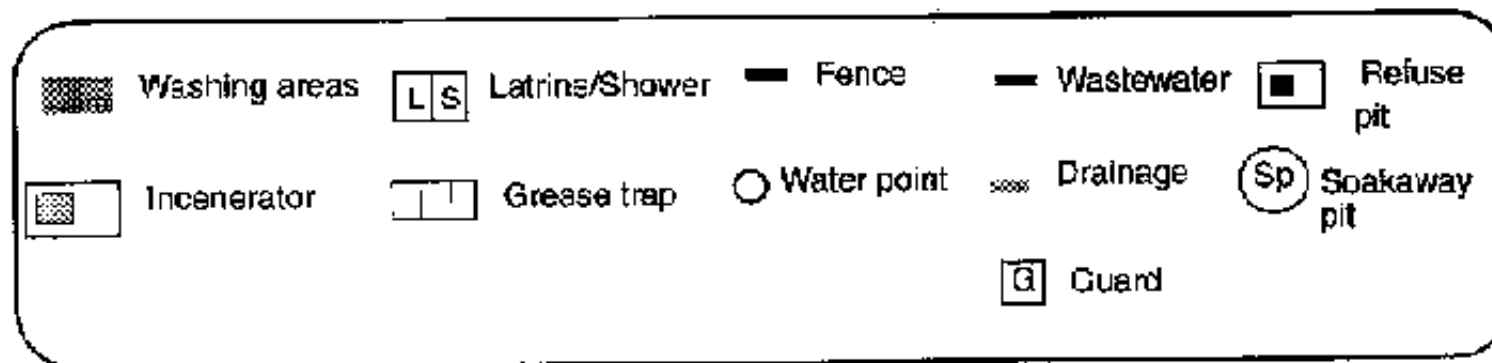

FIGURE

Annex 17a: Example of a Therapeutic feeding centre

Annex 17a : Example of a Therapeutic feeding centre

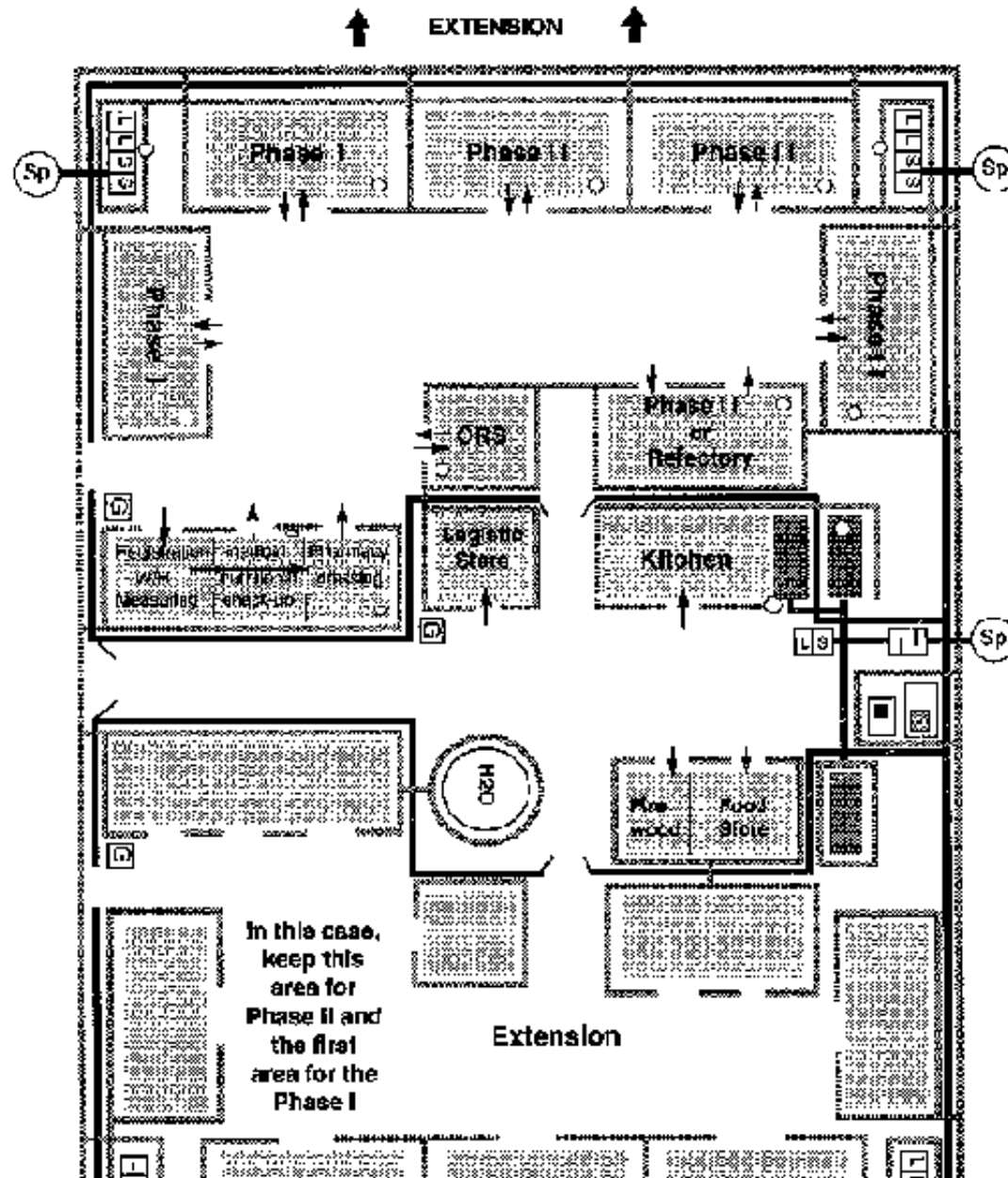

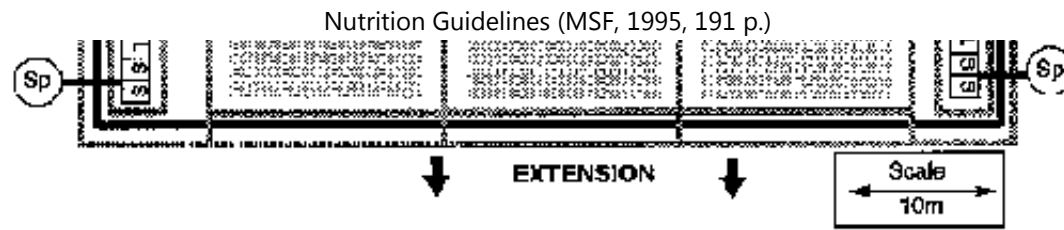

FIGURE

Annex 17b: example of layout of a <<wet>> supplementary feeding centre

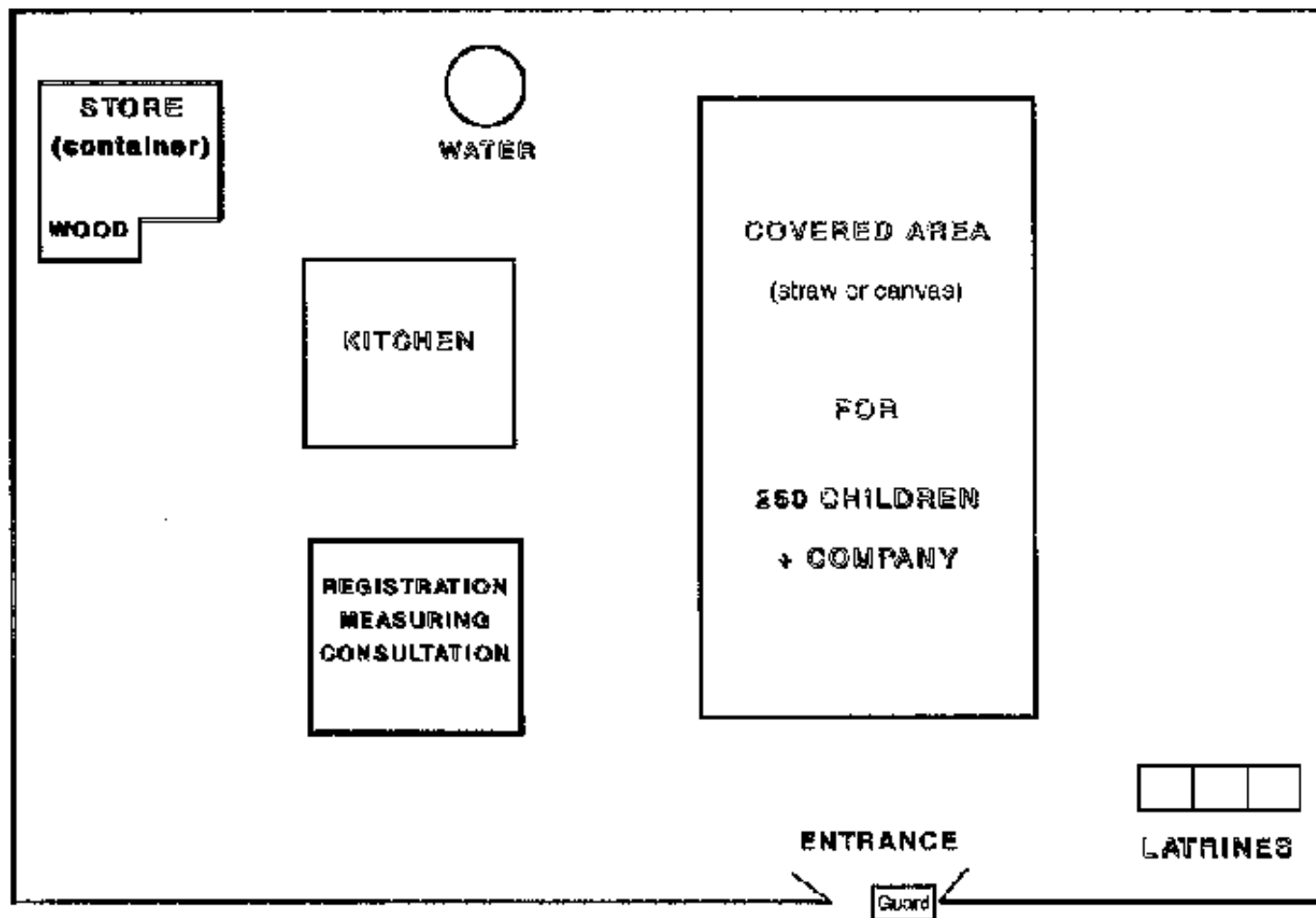

Annex 17b : Example of layout of a supplementary feeding centre

FIGURE

Annex 17c: Example of a DRY SFP

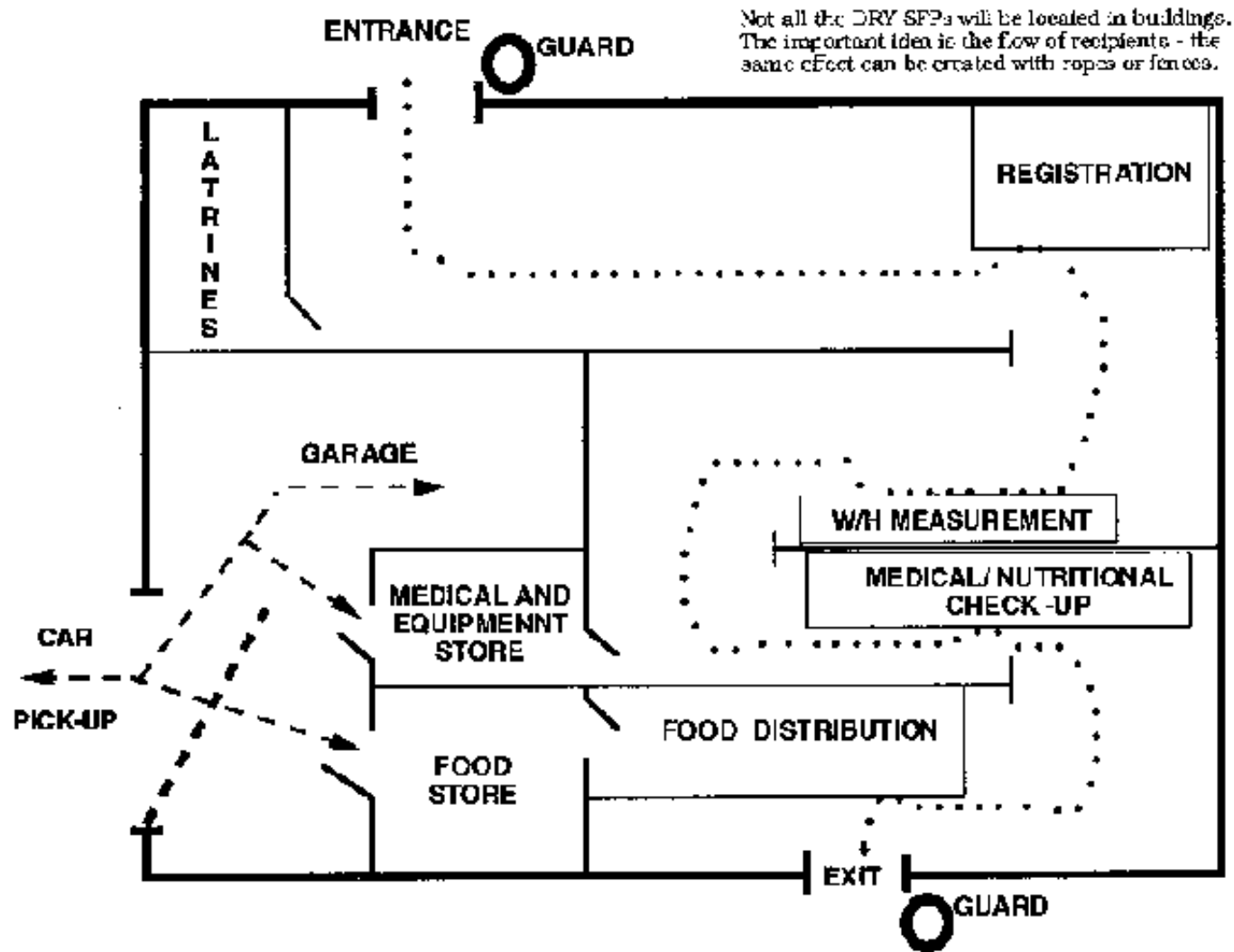

Annex 17c : Example of a DRY SFP

FIGURE

Annex 18a: Example of an Attendance register (tfp or SFP)

1/21

Annex 18a: Example of an Attendance Register (TFP or SFP)

Bracelet I.D.N°	Name	Entry date 24/10/94						Week 1				Week 2				Week 3																				
		Age	Sex	Weight	Height	% W/H	Oedema	24/10/94	25/10/94	26/10/94	27/10/94	28/10/94	29/10/94	30/10/94																						
		023	Fernando X.	16	M	+	-	+	-	-	-	-	-	-	-																	
024	Paquita M.	5	F																																	

+ = present - = absent D = defaulter R = re-admission C = recovered M = death T = transfer

FIGURE

Annex 18b: Example of a Nutritional Status Monitoring (SFP)

Annex 18b: Example of a Nutritional Status Monitoring Register (SFP)

Entry Date	Bracelet I.D. N°	Name	Age	Sex	Weight	Height	% W/H	Target	Medical Care	Date	Date	Date	Date			Date	Date	Date	Date			
										W	W	W	W	H	% W/H	W	W	W	W	H	% W/H	
10/2/82	023	Nando X.	16	M		Vit.A													
12/2/82	024	Magrita M.	5	F		Vit.C													

FIGURE

Annex 19a: TFP individual monitoring card

HISTOIRE										
HISTORY										

VACCINATIONS (dates)				
	1	2	3	4
BCG				
POLIO	naissance/ce birth			
ROUGEOLE MEASLES	6 mois 6 months	6 mois 6 months	9 mois 9 months	9 mois 9 months

ALIMENTATION										
Nouriture / Food						Kcal/jour / Jcal/day				

EXAMEN CLINIQUE CLINICAL CHECKUP										
Anémie/ Anemia										
Déshydratation/Dehydration										
Diarrhée/Diarrhoea										
Température										
Infection respiratoire Respiratory infection										
Vomissements/Vomiting										

OBSERVATIONS

FIGURE

OBSERVATIONS	
---------------------	--

FIGURE

Annex 19b: SFP individual monitoring card

Annex 19b : SFP individual monitoring card

CENTRE DE NUTRITION / FEEDING CENTER* SUPPLEMENTAIRE / Centre de jour / SUPPLEMENTARY/Day care*

TRAITEMENT / TREATMENT

Médicaments / Drugs	Dosages	Voie d'administration / Administration mode	Durée/Duration
Aliments / Type of food	Kcal /Jls day	Nombre de repas / Number of meals	
TOTAL			

EXAMEN CLINIQUE/CLINICAL EXAMINATION

	+	-
Oedème péribotal / Peribotal edema		
Dermatoses / Dermatoses		
Cheveux décolorés / Hypopigmentation of hair		
anémie / Anemia		
Ascite / Ascites		
Hépatomégalie / Enlarged liver		
Splénomégalie / Enlarged spleen		
Déshydratation / Dehydration		
Dialtée / Diarrhoea		
+ Sang / + Blood		
Poumons clairs / Clear chest		
Fièvre / Fever		
Vomissements / Vomiting		
Conscience vitaminique (voir observation)		
Vizimár deüteleny (see observation)		

Informations personnelles :
 N° : Age :
 Nom de l'enfant :
 Child's name :
 Sexe : homme / femme
 / man / female
 Mère / Mother :
 Père / Father :
 Adresse :
 Address :
 Centre sanitaire :
 Health centre :
 Date d'enregistrement :
 Date of registration :
 Date de sortie :
 Date of discharge :

MÉDECINS SANS FRONTIÈRES

* Payer la mention inedit. Mark off the cases mention.

FIGURE

Annex 19c: Individual card for Supplementary feeding centre

Annex 19c: Individual card for Supplementary feeding centre

CENTRE I.D. N° DAY

--	--	--

SUPPLEMENTARY FEEDING

NAME : _____ SURNAME : _____ AGE : _____ SEX : _____
 CAMP : _____ SECTION : _____ BRACELET I.D.N° : _____
 DATE MEASLES VACCINATION : _____

WEEK	DATE	WEIGHT	HEIGHT	CEDEMA	TARGETED WEIGHT
1					
2					
3					
4					
5					
6					
7					
8					
9					
10					
11					
12					

OBSERVATION AND TREATMENT

OBSERVATION	TREATMENT

DATE OF EXIT : _____

CURED

DEFAULTED:

TRANSFERED

DEAD

FIGURE

Annex 19d: Example of an individual card for dry blanket SFC

Annex 19d : Example of an individual card for dry blanket SFC

Distribution card

Child's name : Nr :		
Age : Sex : F / M		
Father's name :		
Mother's name :		
Date Measles Vaccination :		
Date Vitamin A Supplements (*) 1 st :		
2 nd :		
Month :	Month :	Month :
Dates :		
Month :	Month :	Month :

Month :	Month :	Month :

One 200,000 IU caps. Vitamin A every 3 months.
For children below 8kgs : 100,000 IU every 3 months.
Never give large doses of Vitamin A to pregnant women during the first and second trimester.
(see guidelines for Vitamin A supplementation of pregnant and lactating women).

FIGURE

Annex 20: Feeding programme indicator graphs

It is necessary to follow various indicators to allow an appreciation of how well the programme is functioning - Indicators can be graphed to help interpret trends and interpret different indicators together.

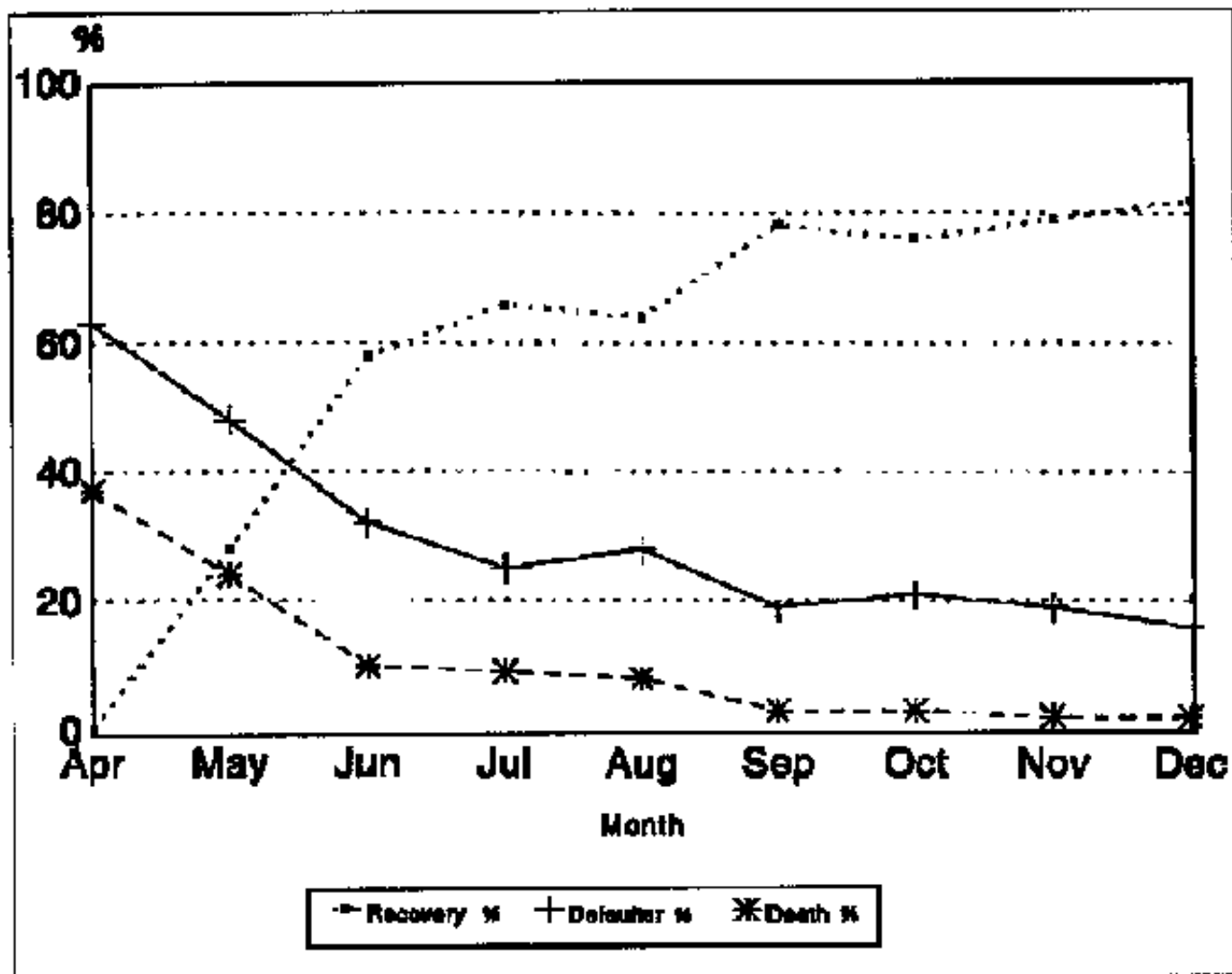

Figure 20a : TFP Outcome Indicators

FIGURE

It is very important to follow the percentages of discharge, defaulting and death. These three indicators can be graphed together to help interpret the three

indicators together and see if the programme is improving or if extra effort is required.

Figure 20a shows an example from a TFP. At the start of the programme, there are very few recoveries as it takes some time to rehabilitate severely malnourished children. Consequently, the proportion of children defaulting and dying is high.

As the programme proceeds, the proportion of children recovering improves as more children are rehabilitated and as the management of the programme improves.

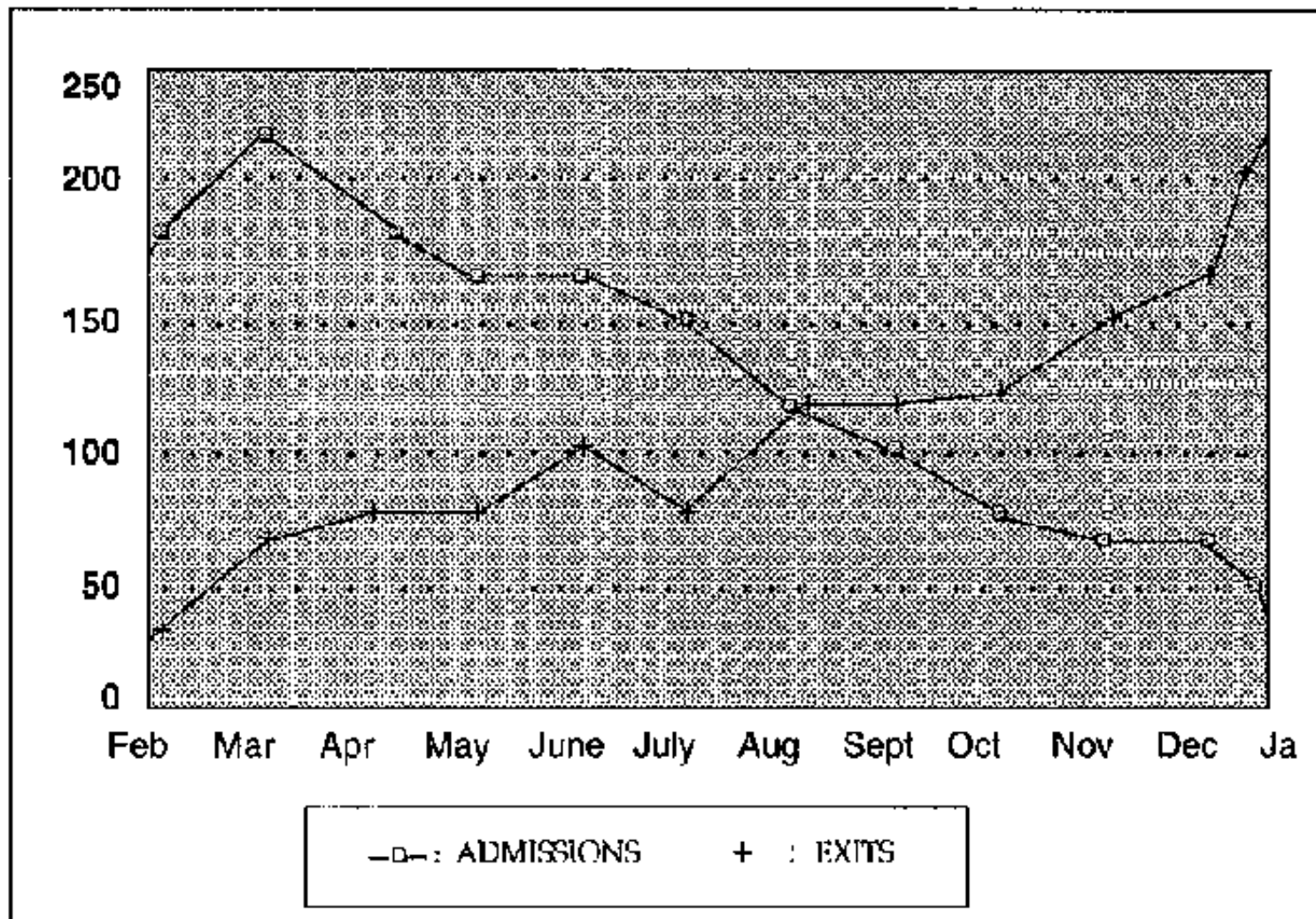

Figure 20b : TFP Admissions and Exits

FIGURE

This graph should be interpreted with an appreciation of the absolute numbers.

Figure 20b shows a graph with the total number of admissions and exits. It shows

how, at the beginning, there is a high rate of admissions and low numbers of exits. Over the course of the programme, admissions decrease and the numbers exiting increase.

CHECK LIST FOR FEEDING CENTRES

CAMP: NAME OF THE SUPERVISOR.

I. STAFF

- 1) Clear job description for each member of the staff**
- 2) Appropriate number of staff (*)**
- 3) A training course has been organized for the staff**
- 4) The planning of the training is respected**

II. FEEDING CENTRE STRUCTURE

- 1) Sufficient space for the present children**
- 2) The different phases of the centre are separated**
- 3) Appropriate number of latrines (*)**
- 4) Appropriate number of showers (*)**

III. FUNCTIONING

· Admission (supervisor or assistant)

- 1) Explanations given to the mother at child's admission**
- 2) The mother receives blankets, matting, a cup, a chamber pot, soap, etc..., for**

her installation

- 3) Criteria for admission respected**
- 4) Medical checking on the day of the admission**
- 5) Good transcription of medical checking on child's record**
- 6) Measles vaccination checked and updated on the record**
- 7) Adequate diet prescribed**
- 8) Diet written down on child's record**
- 9) Systematic treatments correctly prescribed and given**

· Surveillance

- 1) Weight correctly checked**
- 2) Weight regularly checked (*)**
- 3) Weight graph correctly rayed out**
- 4) Daily check-up of children in Phase I**
- 5) Good medical reference system**
- 6) ORS is available and given if necessary**
- 7) Correct medication (hour, prescription respected)**
- 8) Prescribed diets respect the protocol of dietetic care**
- 9) Control by staff of good food intake**
- 10) Duration of stay in Phase I is < 1 week**
- 11) Follow-up of absent children (identification, report)**
- 12) Problems are reported to supervisor (*)**
- 13) Transmission book of staff daily updated**

· Discharge

- 1) Discharge criteria respected**
- 2) Measles immunization up - to - date**
- 3) Transfer form correctly filled (*)**

IV. DATA COLLECTION AND ANALYSIS

- Register book**

- 1) Feeding Centre register book correctly filled**

- Feeding Centre card**

- 1) Feeding Centre cards correctly and fully filled**

- Weekly statistics**

- 1) Weekly summaries correctly filled**
- 2) Graphs regularly done (semester, month)**
- 3) Regular meetings with the Centre's staff**
- 4) Active follow - up of defaulters**

V. WATER - HYGIENE

- 1) Sufficient quantity of water/No of children (*)**
- 2) Drinking water available (*)**
- 3) Sufficient quantity of drinking water /each building**
- 4) Feeding Centre's floor daily washed with chlorine**
- 5) Latrines clean**

6) Dustbin available

VI. KITCHEN

· Kitchen

- 1) The kitchen is big enough for the Centre's capacity**
- 2) Adequate quantity of stoves / children admitted (*)**
- 3) Absence of scraps on floor and shelves**
- 4) Enough material (*)**
- 5) Premix is stocked in a clean and dry place**

· Dish washing area

- 1) Washing area is big enough**
- 2) Washing is properly done (*)**
- 3) The dishes are put away in a clean place**

VII. STORAGE

- 1) Store is big enough**
 - 2) Store is in good condition and the aeration is good**
 - 3) The damaged goods are stocked apart**
- The goods stocking respects the following rules:**
- 4) Store is clean**
 - 5) The rotation rules of the stocks are respected**
 - 6) In and out stock properly recorded**
 - 7) The expiration dates of the goods are controlled**

VII. OTHER POINTS

- 1) Mothers participate in the Centre's running**
- 2) Health meetings are organized in the Centre**

Annex 22: MSF nutrition kits

The MSF Nutrition kit was designed to contain all the elements necessary to start a feeding programme quickly. Many of the materials should be available locally and so if there is time it is often preferable to chose your own materials.

The kit lists are also useful for helping decide what you need to run a nutrition programme.

The kits are arranged in modules for different components of a nutrition programme. The kit lists are being updated. Refer to the MSF kit guide for latest kit specifications. MODULE 1: Nutrition Surveys/Surveilliance

MODULE 1 and 2: Screening and Registration to Nutrition Programmes

MODULE 3: Therapeutic Feeding Programmes for 100 Children

MODULE 4: Supplementary Feeding Programmes for 250 Children

All modules will contain the MSF nutrition guidelines - other nutrition books are available through headquarters.

MODULE 1 Nutrition surveys/Screening

- 1 Salter scales (25 kg) and hanging pants**
 - 50 MUAC armbands**
 - 4 Clipboards - folding double for protection of sheets**
 - 4 Exercise books (notebooks)**
 - 8 Pens**
 - 8 Pencils**
 - 4 Rubbers**
 - 4 Sharpeners**
 - 4 Rulers**
 - 4 Indelible marker pens (permanent markers)**
 - 4 Scissors**
 - 1 Calculator - solar**
 - 4 Plasticized W/H tables - in Z-Scores and % of the median**
 - 1 Height boards - MSF plastic or wooden pieces for field construction = to be reviewed.**
 - 2 Rolls of OXFAM sticky measuring tape**
 - 4 Nylon light weight backpacks**
 - 1 Set of instructions for training survey staff**
 - 1 Roll of strong nylon rope (15m)**
 - 1 MSF nutrition guidelines**
 - 1 Manual counter**
 - 1 Expatriate nutritionist**
 - 1 Standard 1 kg weights (to check scales)**
- * Extra salter scale and height board could be ordered separately.**

MODULE 2 Registration (to be used in conjunction with Module 1 for screening and

registering for nutrition programmes - 350 people)**400 I.D. Bracelets - clear + red popper****1000 I.D. bracelets - clear + green popper****4 Register books - hard back A4****400 MSF individual monitoring cards - TFP****1000 MSF individual monitoring cards - wet SFP****4 Card boxes - plastic (size for card A4)****2 Pocket calculator - solar****10 Indelible marker pens****10 Pens****10 Pencils****10 Rubbers****10 Pencil sharpeners****10 Rulers****4 Plasticized W/H tables - in Z-Scores and % of the median****1 Graph paper (packet)****MODULE 3 Therapeutic feeding kit (100 children)****1 100 litres cooking pot with lid****2 50L cooking pots with lids****2 Wooden paddles****120 Mastic cups - 400 ml****120 Plastic bowls****10 Metal teaspoons****500 Mastic teaspoons**

- 4 Measuring jugs - 1 litre**
- 4 Scoops marked for sugar, oil, cam, etc.**
- 4 Ladles - 250 ml capacity**
- 4 Whisks**
- 2 Tin openers**
- 1 Salter scale (25 Kg) and weighing pants**
- 1 Salter scale (50 Kg)**
- 4 Measuring spoons calibrated for measuring 2g and 10g of Potassium chloride**
- 2 Alarm clocks + batteries**
- 4 Scrubbing brushes - floor**
- 4 Scrubbing brushes - pots/pans**
- 4 Plastic water containers (20L)**
- 12 Plastic buckets + lids (10L)**
- 6 Torches + batteries**
- 5 Indelible marker pens**
- 25 Plastic potties**
- 4 Large food mixing bowls/washing up bowls - wide rimmed**
- 1 Adult bathroom scale**

- 500 Water purifying tablets (chloramine)**
- 10 Bars of soap**
- 4 Clipboards**
- 30 Candles + matches**
- 30 Naso - gastric tubes (CH No. 8 Luer)**
- 30 Naso - gastric tubes (CH No. 10 Luer)**
- 60 Syringe (60ml Luer)**
- 1 Pestle and mortar**

200 Milk cards**1 MSP nutrition guidelines****5 Syringe of 20ml (Luer)****2 Water filter****MODULE 4 Supplementary feeding kit (250 children)*****1 Cooking pot - 100L****2 Cooking pot - 50L****3 Wooden Paddles****500 Plastic cups - 400 ml****500 Plastic bowls****500 Plastic teaspoons****10 Metal spoons****4 Scoops****4 Measuring jugs (5L)****1 Measuring jug (1L)****6 Ladles (250 ml)****3 Wisks****2 Tin openers****4 Scrubbing brushes - floor****4 Scrubbing brushes - pots/pans****10 Graduate plastic buckets + lids****8 Plastic water containers (20l)****500 Water purifying tabs****2 Alarm clocks + batteries**

1 Salter scale (50 kg)

1 Salter scale (25 Kg) and weighing pants

1 Measuring spoon calibrated for 2g and 10g of Potassium chloride

5 Indelible marker pens

4 Large food mixing bowls

20 Bars of soap

1 MSF nutrition guidelines

*** This Module is designed for wet supplementary feeding - it can be used for dry supplementary feeding programmes as well but there will be a lot of wasted material. It is advised that dry supplementary feeding programme materials be purchased locally.**

Instructions for the construction of a height measuring board

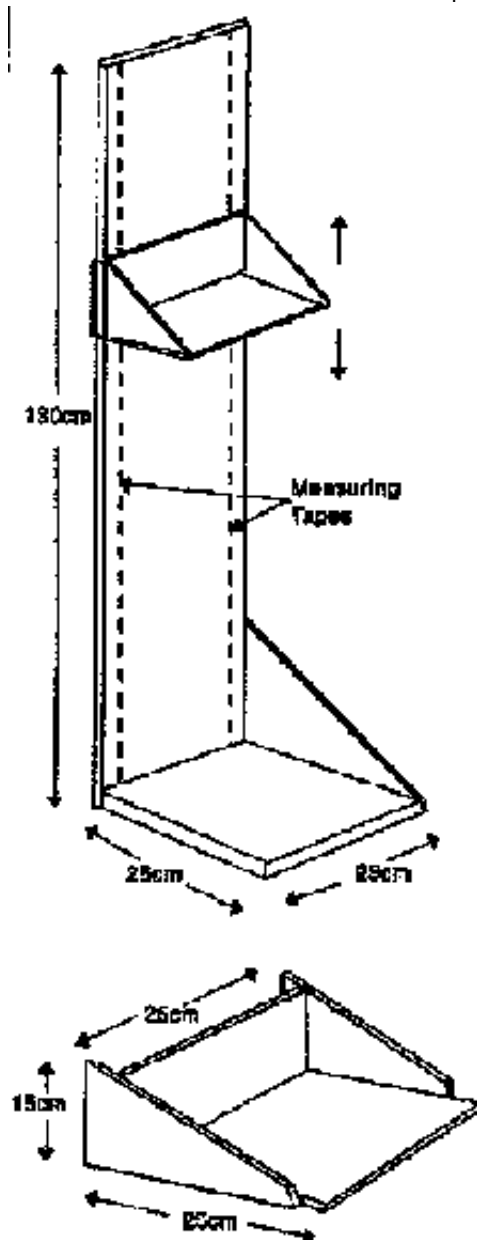
**FIGURE**

The board should be made of strong, but light wood (1 - 2 cm thick). Wood should

be polished to avoid splinters and pieces should be fixed together with screws rather than nails.

Measuring tape should be fixed down either side of the board to make reading the measurement easier when the child stands along the middle of the board.

The tape should be fixed in place by the supervisor of the survey and should be fixed along a ruled line to ensure it is straight and not at an angle. We preferably use OXFAM sticky measuring tape which is designed to minimize errors in reading the measurement. Do not stretch the tape when securing it to the board and make sure that the tape starts at zero at the bottom of the board, flush with the foot piece.

65 cm should be clearly marked children below this should not be measured (too young) unless their age is known.

85 cm should be clearly marked children below this should be measured lying down unless their age is known.

110 cm should be clearly marked children above this should not be measured (too old) unless their age is known.

The sliding head board should be made so that it slides easily up and down the board.

The head piece sides should overlap the height board so that they guide the headpiece up and down the board and minimize sideways movement but the fit should not be so tight that it is difficult to slide the head piece.

[Home](#) > [ar](#).[cn](#).[de](#).[en](#).[es](#).[fr](#).[id](#).[it](#).[ph](#).[po](#).[ru](#).[sw](#)

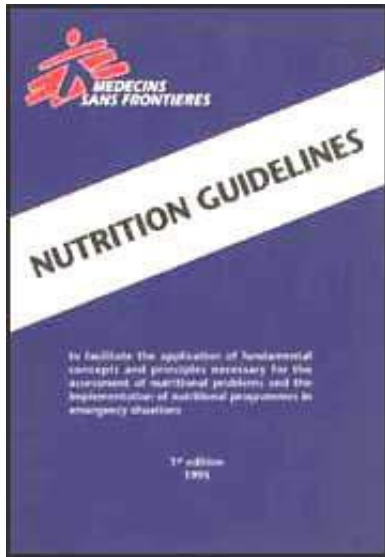

Nutrition Guidelines (MSF, 1995, 191 p.)

 ***(introduction...)***

 **Preface**

 **Part I: Nutrition Strategies in Emergency Situations**

 **Part II: Rapid Nutrition Surveys**

 **Part III Selective feeding programmes**

 **Annexes**

  **Bibliography**

Bibliography

(References, recommended reading)

1 Manual on feeding infants and young children, Cameron M. and Hofvander Y., Oxford University Press, 1983.

2 Nutrition in Times of Disaster, United Nations Administrative Committee for Coordination, Subcommittee on Nutrition, and the International Nutrition Planners Forum. Presented as a report on an international conference; Geneva, September 27 - 30, 1988.

3 Protein - Energy Malnutrition, Waterlow J.C. Eduard Arnold, London, 1992.

4 Prevention of excess mortality in refugee and displaced populations in developing countries, Toole, M. J. and Waldman, R. J. J. Am. Med. Assoc. 263(1990), 3296 - 3302.

5 Selective feeding programmes, Lusty T. and Diskett P., OXFAM Practical Guide No. 1, OXFAM Health Unit, 1984.

6 UNHCR Handbook for emergencies, Part one: Field Operations, UNHCR, Geneva, 1982.

7 Clinical Guidelines, Diagnostic and Treatment Manual, Mdecins Sans Frontires, MSF, Paris, 1990.

8 Essential Drugs, Practical Guidelines, Mdecins Sans Frontires, MSF, Paris, 1993.

9 A Manual for the treatment of diarrhoea, WHO, WHO/CDD/SER/80.2 Rev. 2 1990.

10 Food scarcity and famine; Assessment and Response, Young H., OXFAM Practical Guide No. 7, OXFAM 1992.

11 Guidelines for training community health workers in nutrition, WHO 1986; module 3 and 5.

12 Surveillance in Emergency Situations, Hausman B. and Ritmeijer K., MSF, Amsterdam, 1992.

13 Rapid Assessment Procedures for Nutrition and Primary Health Care, Scrimshaw S. and Hurtado E., United Nations University, Tokyo.

14 How to weigh and measure children, United Nations, Department of Technical Cooperation for Development and Statistical Office, New York, 1986.

15 Use and Interpretation of anthropometric indicators of nutritional status, Bulletin of the WHO, 64(6): 929 - 941 (1986).

16 Controlling Iron Deficiency, United Nations Administrative Committee for Coordination, Subcommittee on Nutrition. A state of the art review. No. 9. ACC/SCN, Geneva, February 1991.

17 Delivery of Oral Doses of Vitamin A to Prevent Vitamin A Deficiency and Nutritional Blindness, West K.P., Sommer A. A state of the art review. No. 2. ACC/SCN, Geneva, June 1987 (reprinted June 1993).

18 Appropriate uses of anthropometric indices in children, Beaton G., Kelly A., Kevany J., Martorell R. and Mason J. A state of the art review. No. 7. ACC/SCN, Geneva, June 1990.

19 Malnutrition and Infection, Tomkins A. and Watson F. A state of the art review. No. 5. ACC/SCN, Geneva, June 1989 (reprinted June 1993).

20 Issues in the assessment of nutritional status using anthropometry, Gorstein J., Sullivan K., Yip R., de Onis M., Trowbridge F., Fagans P. and Clugstone G. Bulletin of the World Health Organization, 1994, 72 (2): 273 - 283.

