


➔  **Operation and Maintenance of Water and Sewerage Systems (Ministry of Water - Tanzania - Rwegarulila Water Resources Institute, 1999, 90 p.)**

 **(introduction...)**

**A. Maintenance of Water Supply Units Principles and General Procedures**

 **1. Introduction**

 **2. Operation and maintenance**

 **3. Inspections**

 **4. Inspections made before putting the unit into operation for first time**

 **5. Periodic inspections made normally without interrupting the operation**

 **6. Periodic inspections made by interrupting the operations**

 **7. Remedial measures**

















 **8. Records**





 **9. Maintenance programmes**

**B. Operation and Maintenance in Tanzania**

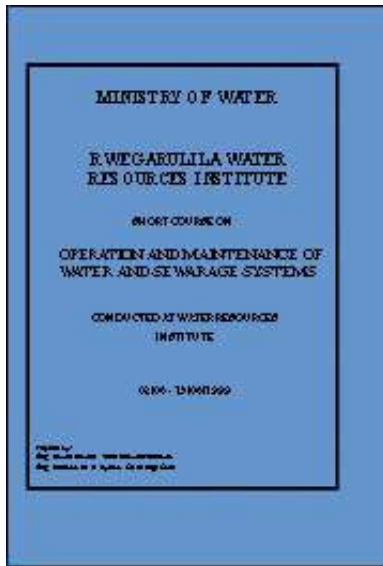
 **1. What is operation and maintenance**


 **2. Constraints of operation and maintenance**

-  **3. Strategies for operation and maintenance on sustainable basis**
-  **4. Operational problems**
- C. General Guide Lines in Construction of Water Structure**
  -  **1. Intake structures**
  -  **2. Pumping stations**
  -  **3. Rising main**
  -  **4. Water treatment**
  -  **5. Gravity main**
  -  **6. Water tanks**
  -  **7. Distribution system**
  -  **8. The design of the sewerage system**
- D. Operation and Maintenance Tasks and Their Frequencies**
  -  **1. Water Supply**
  -  **2. Sanitation**
- ANNEXES**
  -  **1. Class Test (in Swahili)**
  -  **2. Evaluation Form (in Swahili)**
- 3. Group work - Operation and Maintenance of the following:**
  -  **- Intake structure**
  -  **- Pumping station**

-  - **Water treatment unit**
-  - **Water mains**
-  - **Water tanks**
-  - **Sewerage systems**

[Home](#) > [ar](#).[cn](#).[de](#).[en](#).[es](#).[fr](#).[id](#).[it](#).[ph](#).[po](#).[ru](#).[sw](#)



 **Operation and Maintenance of Water and Sewerage Systems (Ministry of Water - Tanzania - Rwegarulila Water Resources Institute, 1999, 90 p.)**

  **(introduction...)**

- A. Maintenance of Water Supply Units Principles and General Procedures**
- B. Operation and Maintenance in Tanzania**
- C. General Guide Lines in Construction of Water Structure**
- D. Operation and Maintenance Tasks and Their Frequencies**
- ANNEXES**

**MINISTRY OF WATER**

**RWEGARULILA WATER  
RESOURCES INSTITUTE**

**SHORT COURSE ON**

# OPERATION AND MAINTENANCE OF WATER AND SEWAGE SYSTEMS

CONDUCTED AT WATER RESOURCES  
INSTITUTE

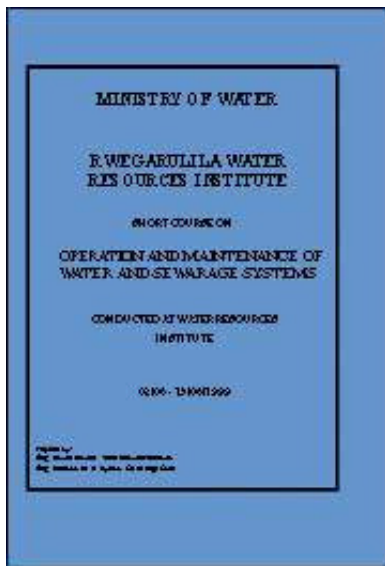
02/08 -13/08/1999


Prepared by:

Eng. Novati Karwani - Water Resources Institute

Eng. Katembo M. K. Nyanza - O&M Maji Coast

[Home](#) > [ar.cn.de.en.es.fr.id.it.ph.po.ru.sw](#)



 **Operation and Maintenance of Water and Sewerage Systems (Ministry of Water - Tanzania - Rwegarulila Water Resources Institute, 1999, 90 p.)**






  **A. Maintenance of Water Supply Units Principles and General Procedures**

 **1. Introduction**

 **2. Operation and maintenance**

 **3. Inspections**

 **4. Inspections made before putting the unit into operation for first time**

-  **5. Periodic inspections made normally without interrupting the operation**
-  **6. Periodic inspections made by interrupting the operations**
-  **7. Remedial measures**
-  **8. Records**
-  **9. Maintenance programmes**

**Operation and Maintenance of Water and Sewerage Systems (Ministry of Water - Tanzania - Rwegarulila Water Resources Institute, 1999, 90 p.)**

## **A. Maintenance of Water Supply Units Principles and General Procedures**

### **1. Introduction**

**The problems of planning, design, and construction of water supply systems are usually slight when compared with the problems of operation and maintenance of the systems, after they have been constructed.**

**The situation is aggravated by the glamour attached to new construction and the greater importance given to expenditures for new construction in contrast to expenditures which are necessary for operation and maintenance.**

**Once the units have been constructed, it is necessary to ensure that they have lasting reliability and will continue to function as intended.**

**The basic requirements for this are that the units have been constructed properly**

**and that they are kept in a state of good maintenance.**

## **1.1 The Problem**

**Cracks in masonry or concrete, leaky covers, damaged or defective pipes, vents, screens, etc., facilitate the entry of ground water and/or surface water and small animals which will contaminate the water and cause health hazards. Water will be lost as a result of cracks, leaky pipes, untight pipes passages through walls, etc. and joints. Metal parts rust. Corrosion leads to loss of water and contamination. Sediment can cause blockages, and affects the yields of wells and springs.**

**Valves not functioning properly will impede operation and cause loss and contamination of water. Clogged intakes, sand traps and screens do not only affect the proper functioning of the units and equipment, but they can also lead to contamination of the water and damages to equipment.**

**The water tight backfill can be damaged by excavations or by deep cracks in the soil; thereby allowing surface water to enter into the system and to cause health hazards. In the long-run the safety of the structure itself can be endangered because of cracks in itself and/or the adjacent ground and as a result of ground water and/or surface water entering through the cracks.**

**Inadequate operation and maintenance leads to breakdowns involving water loses and interruptions. Water supply interruptions and water loses do not only affect the consumers, but they will also reduce the revenue. Reduction in revenue means less funds for operation and maintenance. This in turn results in inadequate operation and maintenance thereby completing and repeating the cycle of the**

**vicious circle. If money has been borrowed for the construction of the water supply system loan repayment will be in areas; aggravating the situation.**

## **1.2 The Solution**

**The solution is the execution of a maintenance programme which works.**

**Maintenance of a water supply unit is based on three considerations.**

- 1. structural;**
- 2. operational; and**
- 3. hygienic.**

**Maintenance work must be carried out in time in order to prevent or at least minimize the possibilities of structural damages, interruption of service, contamination of the water and increases in the cost of repairs.**

## **2. Operation and maintenance**

**A water supply system is designed and constructed for the purpose of providing an uninterrupted supply of adequate and safe water.**

**Proper design and construction will ensure that the unit or system will function as intended provided it is operated and maintained properly.**

**After the construction is completed the system is handed over to people who are responsible for running it. Their work includes operation and maintenance which attempts to ensure that the various components of the system do function as**

**intended and render the desired service.**

## **2.1 Operation**

**Operation refers to the performance of activities and use of resources for making a structure, a machine, an equipment, or a system of production do the work it is intended to do. To operate satisfactorily the system and its parts must be in a condition to do their intended work when given the necessary complementary inputs of labour, energy and raw materials.**

## **2.2 Maintenance**

**All types of structures, machinery, or equipment, units, or system of production tend not to do the work that they are intended to do; or not to function at all, unless special efforts are made to maintain them and restore their capacity.**

**Maintenance mean making periodic inspections which are necessary to determine the extent of this negative tendency, carrying out appropriate remedial measure, and keeping records of the observed deficiencies and the works carried out.**

**The word maintenance is normally used to describe one of two distinct types of activities: preventive maintenance. The other type is corrective (curative) maintenance.**

**Preventive maintenance is that which is conducted to minimise malfunctioning, failures or breakdowns; corrective maintenance is that which is carried out after the damage or break down has occurred. A preventive maintenance programme cannot hope to prevent all failures or breakdowns, thus some corrective**



**maintenance will have to be carried out from time to time. A successful preventive maintenance programme will result in less frequent failures and shorter interruptions of service.**

**The discussion on preventive maintenance in this Module concerns itself with the technical aspects of water supply units.**

## **2.3 Curative Maintenance**

**Cases of emergency are examples of curative (corrective) maintenance and have to be dealt with as they occur.**

**The main cause of breakdown or malfunctioning of the unit may or may not be obvious at once. In any case the most obvious measures shall have to be taken immediately followed by systematic inspections in order to make a reliable job. At such inspections representatives of authorities who are concerned with the safety and stability of the structure, the operation of the units, and the quality of the water, should be present if possible.**

## **3. Inspections**

**Inspection consists of checking the physical conditions of a structure and its surroundings.**

**Inspections are made in order to find out what is missing, gone wrong, or about to go wrong and to decide on the remedial actions that have to be taken.**

### **3.1 Scope of Inspections**

**The inspections shall be made in order to assess the conditions of the units and determine the steps to be taken to remedy the deficiencies. Thereby, equal emphasis should be placed on the**

- structural;**
- operational, and**
- hygienic**

**aspects.**

**The conditions will show whether and to what extent the deficiencies adversely affect**

- the safety and stability of the structure;**
- the proper operation of the unit; and**
- the quality of the water.**

### **3.2 Extent of Inspections.**

**A record should be made of the observed deficiencies.**

**Water samples should be taken. Notes should be made on the accumulation of sediments, the presence of small animals and the origins of small animals.**

**The inspection must look out for**

- rock pockets (porous, mortar deficient portions of hardened concrete consisting primarily of coarse aggregate and open voids; caused by leakage**

**from formwork, or separation during placement of concrete or insufficient consolidation, or both);**

- cracks;**
- insufficient bond of screeds and plaster;**
- cavities under screeds and plaster;**
- roots (these are an indication for cracks and harmful connection with the exterior);**
- roofs and covers which are not watertight; porous parts; holes; insufficient cover of the reinforcement steel;**
- defective inlet, outlet, overflow, and wash-out pipes;**
- defective measuring facilities; and**
- blocked vents.**

### **3.3 Types of Inspections**

**Inspections can be classified according to the times when they are made. It is necessary to distinguish between three types of inspections.**

- 1. Inspections made before putting the unit into operation for the first time;**
- 2. Periodic inspections made normally without interrupting the operation;**

**and**

**3. Periodic inspection made by interrupting the operations as necessary.**

**4. Inspections made before putting the unit into operation for first time**

**It should be pointed out that even a newly constructed water supply system has to be checked before it is commissioned in order to ensure that it is properly constructed and that it works as intended. This first type of inspection is usually a part of the construction phase.**

**The more painstaking the construction work, and the more thorough the first inspection and the ensuing corrective work the less will be the trouble in the life of the structure as far as the structural condition is concerned.**

#### **4.1 Inspections**

**This first and most important inspection is the inspection which is made after the "completion" of the construction work and before the unit is put into operation for the first time. This inspection and the remedial work which follows it are the basis for a sound structure which will function provided it is properly maintained and operated in the future.**

**The team which was involved in the construction should not make the inspection by itself. The most appropriate members of the inspection team ought to be persons who would be responsible for the operation and maintenance of the unit or system.**

**The team which was involved in the construction would itself have made an**

**inspection of the work and carried out improvement works as necessary before announcing that it is ready to hand over the unit which has been completed.**

**The structures will be inspected by a team whose members represent at least the group which is responsible for the construction on the one hand and the future operation and maintenance on the other hand.**

**In order to facilitate the work the inspection should follow a systematic pattern using a check list.**

**A record is made of the inspection and agreement reached regarding the works (if any) which have to be carried out before the unit is put into operation.**

**The second inspection will verify whether all works agreed upon during the first inspection have been carried out properly.**

## **4.2 Tests**

**Tests are made to check the performance of the completed unit.**

**Water retaining structures including passages of all pipework and fittings which are built - in have to be tested for watertightness.**

**A record is made of the tests and their results.**

## **4.3 Disinfection and putting into operation**

**After the successful completion of the works and the satisfactory results of the**

**tests, the units will be cleaned thoroughly and disinfected. Then the units are put into operation.**

## **5. Periodic inspections made normally without interrupting the operation**

**Structures can be damaged as a result of acts of nature and/or human beings. Damages, caused by human beings can be due to ignorance, carelessness, or abuse.**

**The physical conditions of the units have to be checked frequently. The frequency depends on local conditions. The type and location of the unit and the available manpower are some of the major factors which govern this frequency.**

**This is the essential part of preventive maintenance. Inspection of each unit by at regular intervals is necessary for the detection of structural defects and other faults which may develop from time to time either from fair wear and tear or through external conditions such as ground subsidence or abnormal weather. The roadways, pathways, fences and any buildings should also be inspected regularly with the aim of noting defects for repair. Painwork, particularly of steel water tanks should be well maintained throughout the waterworks.**

**For some of the visual inspections it is not necessary to interrupt the operation. The aim of the inspection is to find any changes or developments in the structure and the surroundings which would adversely affect the safety or stability of the structure, the operation of the unit, and the quality of the water. Basically the inspection concerning the physical conditions is similar to the inspection which is made before the unit was put into operation for the first time. The main difference**

**is that the inspection and the ensuing remedy for the correction of the defects are now the sole responsibility of the maintenance team. However, in cases where major repairs or reconstruction works are necessary a construction team or group can be assigned to carry out the work.**

**Components of units such as valves, vents, overflow pipes, etc., can be inspected without interfering with the operation of the unit in question.**

## **6. Periodic inspections made by interrupting the operations**

**The periodic inspections may sometimes also require the interruption of the service. They are concerned with the inspection of the interior of all water retaining structures. The interruptions have to be made because the chambers shall have to be emptied in order to carry out the inspections and the ensuing necessary works.**

**Such an inspection will be made once a year, once in two or three years depending on the size of the system, the nature of the unit and the source and quality of the water.**

**Such maintenance should be made at times when the water consumption is low. Local conditions and experience will indicate the most suitable month of the year or even the day(s) of the week in that month. Even then preparatory work is necessary. All tools and equipment as well as materials and labour should be organised before the chambers are emptied and the maintenance works (= inspection + remedial action + records) started.**

**When the necessary maintenance does not require a long time, the impact of the**

**interruption of service (if any) will not be too hard on the consumers. In any case the consumers ought to be informed in advance. They shall then be able to reserve some water and to programme their domestic activities. This also minimizes any inconvenience due to repairs which might take time in excess of the average.**

## **7. Remedial measures**

**Remedial activities of maintenance include**

- 1. Repair, replacement, etc., of parts which are damaged, worn or become obsolete;**
- 2. Removal of unwanted external and internal waste build-up;**
- 3. Application of protective paint;**
- 4. Cleaning;**
- 5. Disinfection; and**
- 6. Public relations and education.**

**The details of the remedial measures should be laid down in writing. Some persons may be able to carry out the job without such written guidelines. What should be strived at is the cultivation of positive habits both during the training and the actual performance of duties. Only thus it will be possible to ensure that the maintenance work is carried out in a systematic manner.**

## **8. Records**

**Records are required to provide information on which future actions can be based.**

### **8.1 Records of the system and extensions**



**These would include records (such as as-built drawings) of the various units of the waterworks. Instances are not uncommon, where the position of some valve or pipe is known only by one or two persons, usually the oldest employees. Such situations must be corrected.**

**Each water supply plant should have an up-to-date layout plan of the waterworks. Or units of which the line of every pipe and the location of every valve are clearly marked. Each valve on the plan should be numbered and the number painted on or near the actual valve. Such a plan is particularly useful whenever there is a change of attendant or in cases of emergency. Any extension work is done to the system it should be recorded, preferably with a sketch. These records, if kept in a systematic manner, will provide ease of reference to any portion of the system. Alterations to all works should be recorded also.**

## **8.2 Records of Maintenance**

**Records of maintenance are very important. They should clearly describe the deficiencies and the remedial measures that have been carried out. Whenever possible, the written descriptions ought to be supplemented with clear sketches.**

**All happenings affecting the works; actual works carried out, routine or unusual, (occasioned by accidents, breakdowns or other conditions), should be recorded as they occur. Copies of log sheets should be forwarded to the head office.**

**At least a simple log book or log sheet should be kept at even the smallest works. Any troubles that occur and the date when they are put right should be recorded also. Any sign of wear or damage should be noted in a diary and reported so that**

**spare parts may be obtained on time. Records should also be kept of repairs that are required. The maintenance jobs that must be done at infrequent intervals should be marked in a diary in advance so that they are not forgotten.**

**From these records isolated and frequent troubles can be pinpointed, an efficient schedule for personnel planned, and estimates for operation and maintenance made with reasonable accuracy.**

**Further maintenance records will facilitate evaluation and monitoring as well as planned maintenance including the improvement of future design and construction.**

### **8.3 Recording of Information**

**Any modification, change or improvement in the system, unit, etc., is to be incorporated in the records as it occurs. Information should be recorded as soon as it is obtained and should not be allowed to accumulate. Such accumulation will deter a start. And when a start is made at last, it will prevent a good progress; as there will always be something which is more important or more urgent. Experience shows that recording of accumulated data is doomed to contain mistakes.**

### **8.4 Keeping of Records**

**An annual report summarizes the records for each water supply system. It helps to assess future maintenance requirements, warns of possible extensions that may be required.**

**It is also most important to prepare certain special reports which are then distributed to those concerned.**

## **9. Maintenance programmes**

**It should be appreciated that it will not be possible to design and implement a maintenance programme which will satisfy all conditions everywhere. An individual schedule must be worked out for each individual system taking into consideration the local conditions. It should be remembered that such a schedule is dynamic and ought to be modified and improved all the time. The reports and records on the system and its maintenance will greatly help in the elaboration of the details for the modification and improvement of the maintenance schedule. A systematic maintenance programme based on records and realistic schedules and provided with the necessary logistics will ensure a reliable service with less frequent breakdowns and shorter interruptions.**

### **9.1 Components of Maintenance Programme**

**In order to be effective a maintenance programme must have sound**

- administrative;**
- financial; and**
- technical**

**components.**

**The discussion in this Module deals with the technical aspects only. It should be pointed out, however, that the technical measures cannot be fully realized without**

## **the necessary administrative and financial support.**

### **9.2 Inventory**

**In preparing a maintenance schedule for the first time one should start with a survey of the water supply systems and make an inventory of all components and units of the systems. Details of each unit should be recorded separately on suitable simple forms which could eventually provide a complete history of the unit and thus of the system of which it is a part. In case there are no previous records, the second thing to do will be to complete the records as appropriate where possible.**

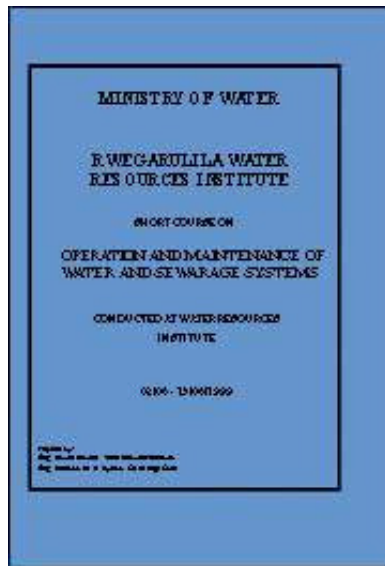
### **9.3 Tasks**


**After the completion of the inventory, the tasks to be carried out and their frequency shall be determined taking into account local conditions and experience. Presentation should be best in tabular form.**

### **9.4 Schedules**





**The work schedule which may be tabulated should show the work to be done at the prescribed frequency at every location. The individual items can be given reference numbers and the frequencies figures or signs to show whether the tasks are weekly, monthly, quarterly, six monthly, yearly, etc., in order to make the tabulated summaries handy.**





 **Operation and Maintenance of Water and Sewerage Systems (Ministry of Water - Tanzania - Rwegarulila Water Resources Institute, 1999, 90 p.)**

  **B. Operation and Maintenance in Tanzania**

-  **1. What is operation and maintenance**
-  **2. Constraints of operation and maintenance**
-  **3. Strategies for operation and maintenance on sustainable basis**
-  **4. Operational problems**

**Operation and Maintenance of Water and Sewerage Systems (Ministry of Water - Tanzania - Rwegarulila Water Resources Institute, 1999, 90 p.)**

**B. Operation and Maintenance in Tanzania**

**1. What is operation and maintenance**

**As soon as construction of a water supply or sanitation project has been completed, operation and maintenance of the project begins. Operation means the making of a project to deliver the intended benefits in terms of water services to the beneficiaries. In order to make the water project to continue to deliver the optimum service over a considerable time, components of the project must be properly operated and properly maintained.**

**Operation and Maintenance is crucial to the successful management and sustainability of water supply and sanitation systems, whatever the level of technology, infrastructure and institutional framework.**

## **2. Constraints of operation and maintenance**

**In our country, for the past many years most of the water supply schemes have been initiated and constructed by donors, be it the government or non governmental organizations. Operation and Maintenance of the schemes had taken separate scenarios in rural areas and in urban areas. In rural areas, Operation and maintenance used to be taken up by the government, from the supplying of fuel, spare parts, pipes, tools and paying of salaries of skilled and unskilled personnel attending the schemes. The beneficiaries practically paid nothing. Water supply used to be free service to the people who managed to get it.**

**In urban areas, on the other hand, at least people acquiring water service were registered and asked to pay some cost that could cover part of the operation and maintenance cost.**

**In both the cases, the operation and maintenance procedures of the schemes were inadequate. Many of the schemes failed to deliver the service to the expected level and ultimately total collapse of the schemes. Among the many factors that have been found to contribute to inadequate operation and maintenance procedures are:-**

- Low profile of operation and maintenance and the lack of priority given by the policy makers;**

- **Lack of clear policies, appropriate legal framework and a well defined division of responsibilities to support operation and maintenance;**
- **Too much political interference, i.e. provision of free water service, which makes sustainability of the schemes too difficult to achieve;**
- **Government and external support agencies neglect the maintenance of the existing water supply and sanitation schemes in favour of construction and expansion;**
- **Poor management and overlapping responsibilities within projects and agencies, diverting funds away from Operation and Maintenance**
- **Inappropriate design and technology choice, often caused by a lack of community involvement in project development;**
- **Inadequate access to data and field experiences about operation and maintenance for use in planning operation and maintenance strategies;**
- **Insufficient funds and misuse of funds earmarked for operation and maintenance, restricting availability of spare parts, tools, recruitment and training of competent staff.**
- **Inappropriate management at community level.**

### **3. Strategies for operation and maintenance on sustainable basis**

**These days Government and external support agencies, as well as communities**

**are increasingly concerned about the importance of integrating operation and maintenance components in the planning, implementation, management and monitoring of project activities.**

**It has been realised that operation and maintenance is not just a technical issue. Operation and maintenance encompasses social, gender, economic, institutional, political, managerial and environmental aspects. Water must be looked at as an economic good and therefore the communities or the water users must pay for the water they use.**

**For the increasing demand of potable water and sanitary services; the increasing population, town and municipalities, it is not possible for the Government alone to meet all costs of operation and maintenance. Many water service systems which had entirely depend on government to operate and maintain have stopped to give the service and the structures have remained as white elephants. The Government and other donors have gradually changed their role as provider of services to that of a facilitator of the process. Communities who are the water users must be involved in selecting the type of service they want and can afford and must take the responsibilities, not only in Operation and maintenance of their water supply systems, but also in the financial management of there systems.**

**Private entrepreneurs from both formal and informal sectors must be welcomed to participate in the operation and maintenance. The move to privatize DAWASA in Dar es Salaam Water Supply system, the formation of water users boards in municipalities and towns and the rural areas are some of the strategies for operation and maintenance being undertaken in our country. At all levels more integrated operation and maintenance strategies must be initiated and developed,**



**in which the concerns of safe water environmental sanitation and hygiene education are simultaneously tackled.**

**In rural areas involvement of women in Operation and Maintenance of water supply is very crucial. This is because Women are the principal users of water supplies and must be given prominent role in management and maintenance activities. Women are major motivators for repair in case the system breakdown. Another important strategy in Operation and Maintenance is management. Community management emphasizes the communities own decision making power over those water supplies and sanitation components for which they hold or share responsibility.**

**Payment of recurrent cost is often the greatest problem a community water board faces. The basis for successful community financing of Operation and Maintenance, recurrent cost is already formed during planning; the choice of technology and the service level must be within the technical, financial and managerial resources of the community. The community water board must choose a financing system which matches its situation, be it a communal fund, flat rates, graded rates, mixed system, water metering, coin operated or vending.**

**The finances must be well managed. This requires a wisely chosen community water organization, practical training of member of the committee in budgeting and financial administration, and strong measures for financial control e.g. auditing and regular accounting to water users.**

**Financing of sanitary facilities is probably even more difficult than of water supply facilities. The financing mainly refers to capital cost. The recurring costs are**

**generally considered to be a household responsibility.**

## **4. Operational problems**

### **4.1. Quality of Water**

- **Turbidity**
- **Bacterial contamination**
- **Odour**
- **Conductivity**
- **Hardness**
- **Algae, etc.**

### **Turbidity of Water May come from**

- **Pumping station**
- **Pipe material (especially Cast Iron)**
- **Network fouling**

### **Quality measurement Methods**

- **Single samples**
- **Continuously monitoring**

### **Prevention of Contamination**

- **Always/pressure on the system (DAWASA!)**
- **Water pipe not close to servers or pit latrines (KIBINDU incidence)**

- **Avoid penetration of ground water during pipe laying/repair.**
- **Cover pipe ends during storage, transport to prevent infection by rain, dust, soil, animals.**
- **Brush pipe ends and joints**
- **After pipe laying/repair:**

**For  $\varnothing < 100\text{mm}$  - clean pipe by flusting before putting into use**

**For  $\varnothing > 100\text{mm}$  - clean pipeline by flusting, swabbing (use of pigs)**

**- If possible disinfect by filling with 20 mg/L active C/2 for 12-24 hours, followed by bacteriological sampling before putting pipe into use.**

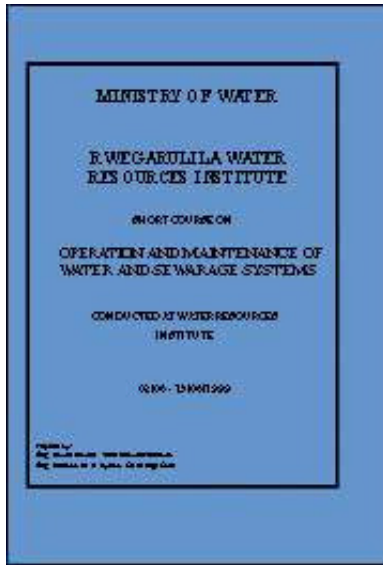
## **4.2 Quantity of Water**


- **Source not sufficient**
- **Population growth/migration**
- **Rapid industrial development**
- **Excessive leakages**
- **High peak factor**

## **4.3 Administrative problems**









- **Quality control**
- **Leakage control**
- **Tariffs and revenue**
- **Crossing roads in new connection**
- **None Revenue Water etc.**

[Home](#) > [ar](#).[cn](#).[de](#).[en](#).[es](#).[fr](#).[id](#).[it](#).[ph](#).[po](#).[ru](#).[sw](#)



 **Operation and Maintenance of Water and Sewerage Systems (Ministry of Water - Tanzania - Rwegarulila Water Resources Institute, 1999, 90 p.)**

  **C. General Guide Lines in Construction of Water Structure**

-  **1. Intake structures**
-  **2. Pumping stations**
-  **3. Rising main**
-  **4. Water treatment**
-  **5. Gravity main**
-  **6. Water tanks**
-  **7. Distribution system**
-  **8. The design of the sewerage system**

**Operation and Maintenance of Water and Sewerage Systems (Ministry of Water - Tanzania - Rwegarulila Water Resources Institute, 1999, 90 p.)**

**C. General Guide Lines in Construction of Water Structure**

**1. Intake structures**

**1.1 Outline of Intake Structures**

**Intake is a well type masonry or concrete structure, whose function is provide clam and still water, free from floating matter for water supply schemes. Its main purpose is to provide calms and still water conditions so that comparatively pure water may be conveniently collected from the source. While selecting site for locating the intake, the below mentioned points should be carefully attended to:-**

**(i) Intake work should provide purer water so that its treatment may become less exhaustive.**

**(ii) Heavy water currents should not strike the intake directly. This aspect can be achieved by suitably shifting the proposed intake.**

**(iii) Intake should be located at such a situation where sufficient quantity of water remains available under all the circumstances.**

**(iv) Site should be well connected by good type of roads.**

**(v) Site should be such that intake should be in a position to provide more water if required to do so.**

**(vi) It should not be located in navigation channels, because water of such channels is generally polluted.**

**(vii) During floods in rivers, flood waters should not be concentrated towards the intake.**

**(viii) It should not be located on the curve of the river. If there is no alternative then intake should be located on the outer bank and not on the**

**inner bank.**

**(ix) Intake should be located on up stream side of the town. Water will not be contaminated on this side due to sewage disposal of the city.**

**In spite of all the effort and precautions, problems may still be there due to natural causes. Temperature, seasonal variations in quantity and quality, wind currents etc. may affect the stability and safety of the intake works.**

## **1.2 Design of Intake**

**Intake should be designed on the basis of the following considerations:-**

**(i) Intake should be sufficiently heavy so that it may not start floating due to upthrust of water. Also a heavy intake will not be washed away by heavy water currents.**

**(ii) All the forces which are expected to work on intake should be carefully analysed and intake should be designed to withstand all these forces.**

**(iii) The foundation of the intake should be taken sufficiently deep. This will avoid overturning of the structure.**

**(iv) Intake should not be constructed in a navigation channel as possible. If it has to be constructed it should be protected by cluster of piles all round from forces caused by moving ships and steamers.**

**(v) Strainers in the form of wire mesh should be provided on all the intake**

**inlets. This will avoid entry of large floating objects and fishes into the intake.**

**(vi) Intake should be of such size and so located that sufficient quantity of water can be obtained from the intake in all circumstances.**

### **1.3 Types of Intake**

- (i) River intake**
- (ii) Canal intake**
- (iii) Reservoir intake**
- (iv) Lake intake**

### **Intake constructions**

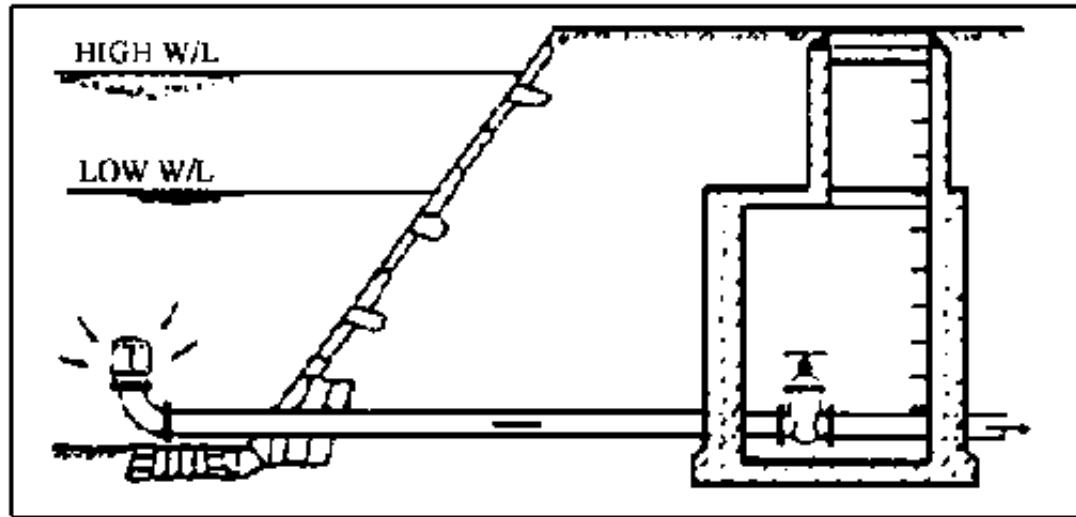
**Intake work = inlet (+pump for suction and transport)**

**Requirements inlet constructions:**

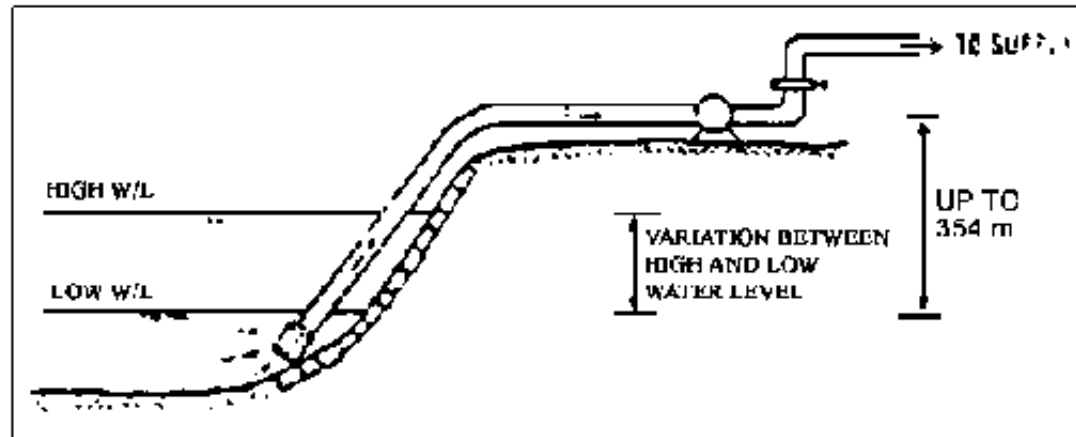
- \* protection inlet against damages (navigation, floods)**
  - \* raw water quality considerations**
    - avoid coarse floating materials and fish**
    - quality at various depth**
- (swing pipe, closeable openings etc.)**

### **Some intake works**

# Intake from a river:

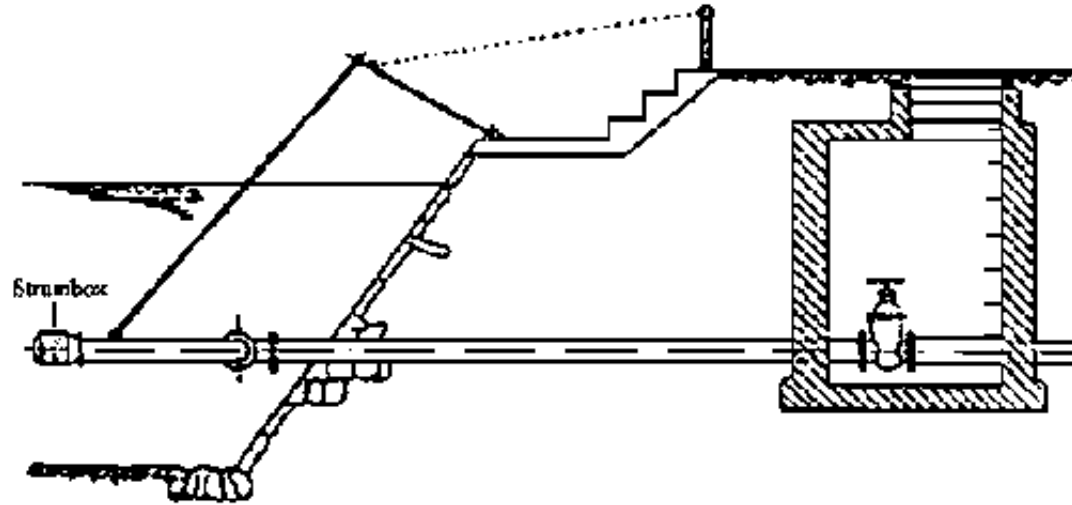


**Unprotected river intake**

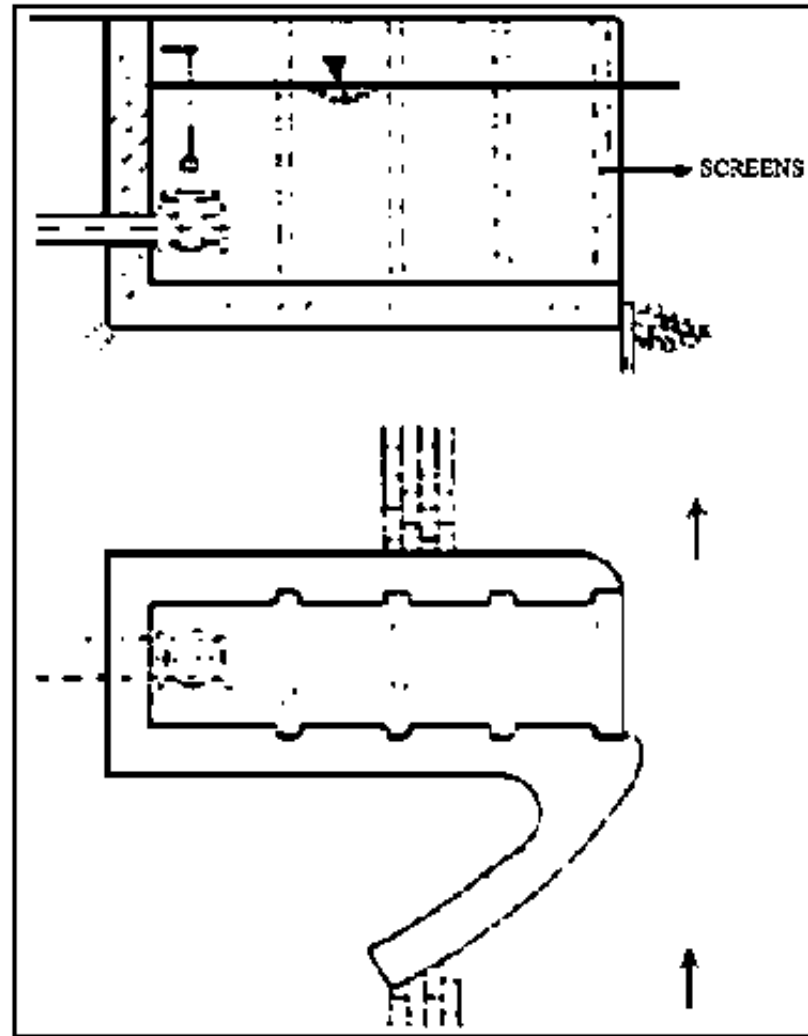


**Pumped river water intake**

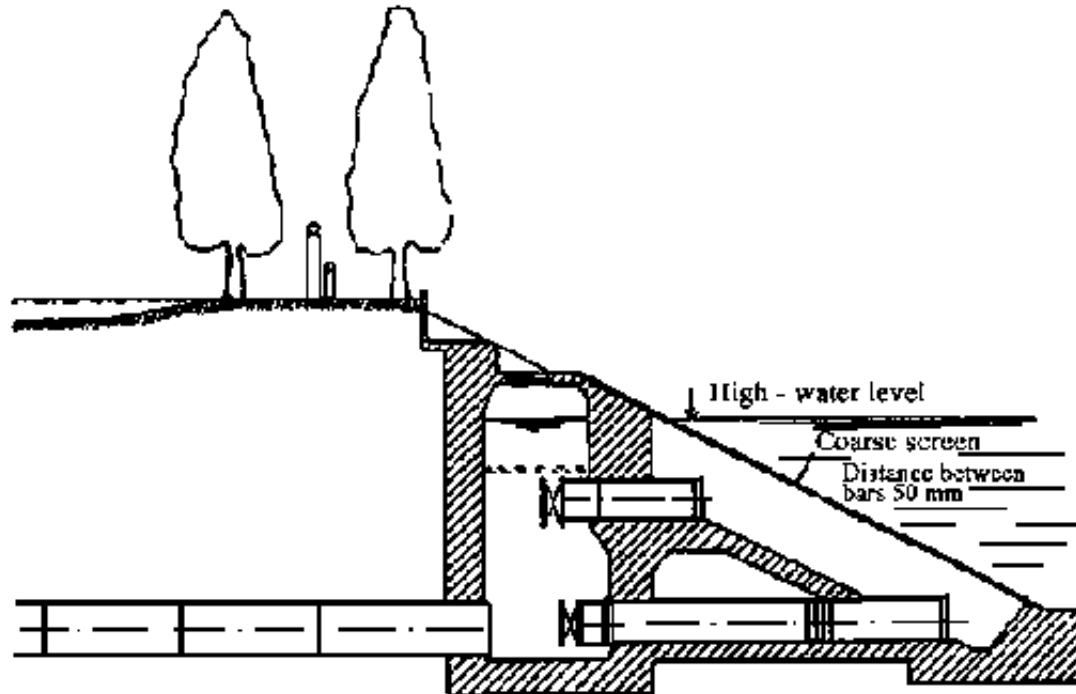




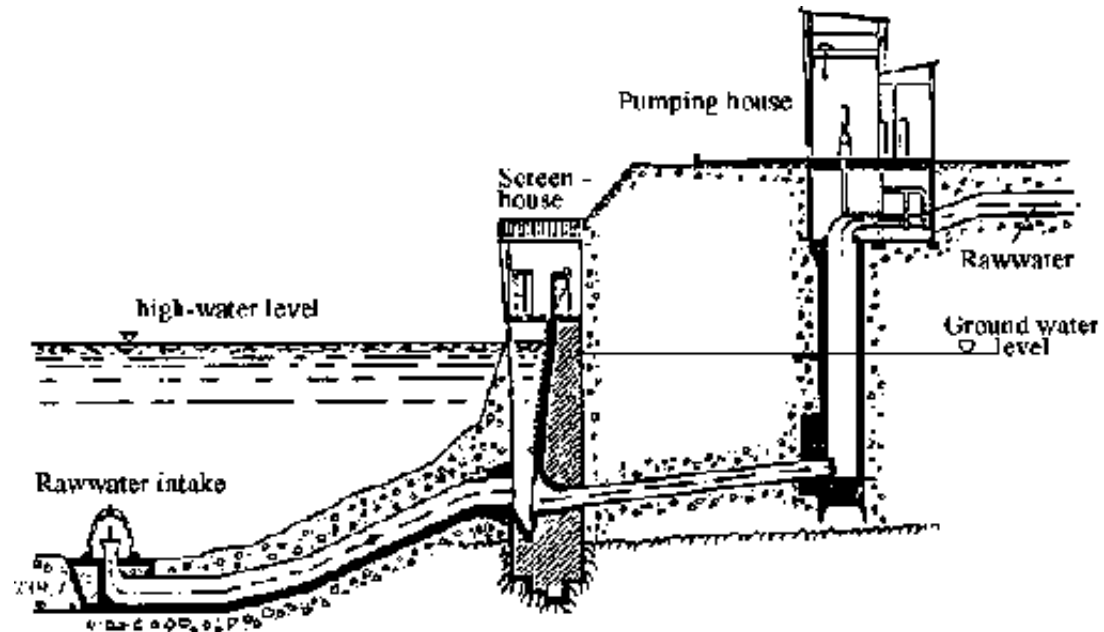
***Movable intake***



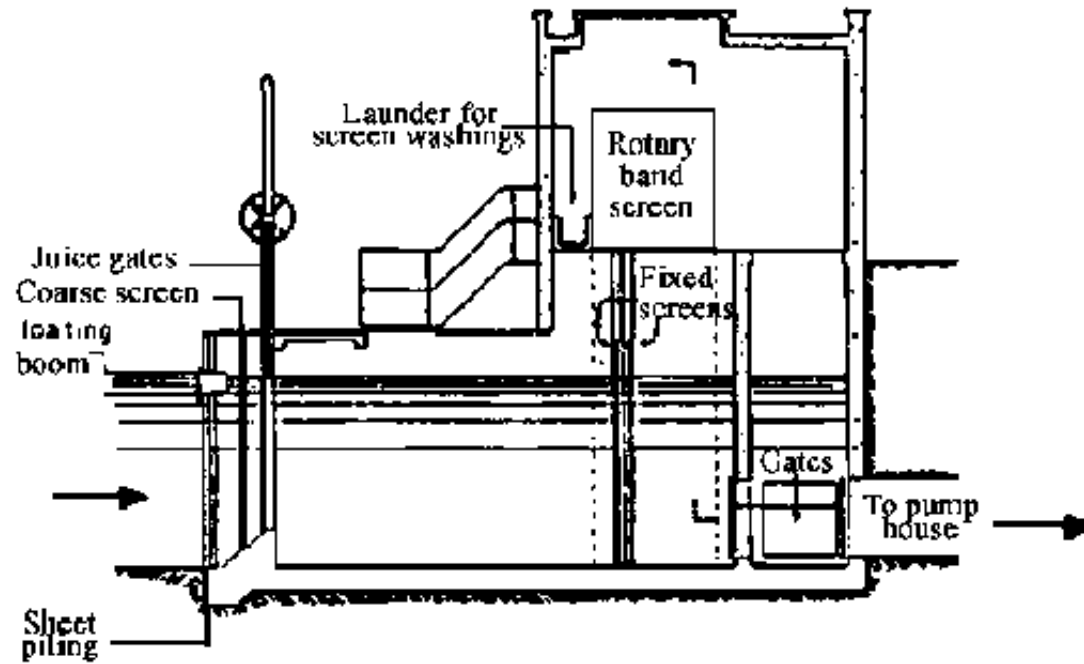
***River intake station***



Figure

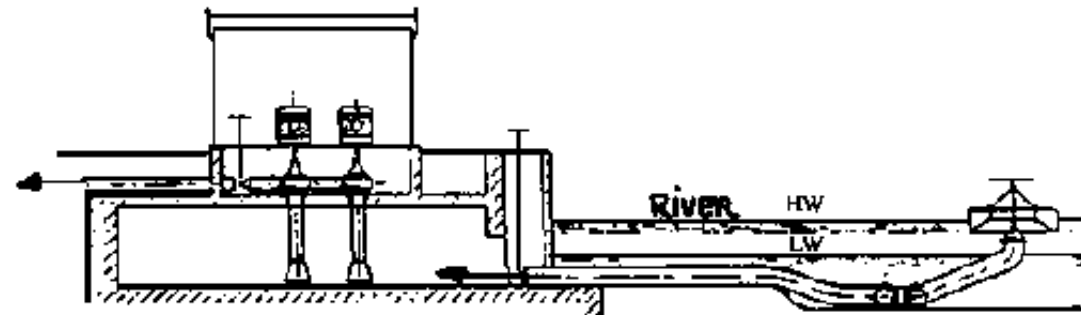


**Figure**

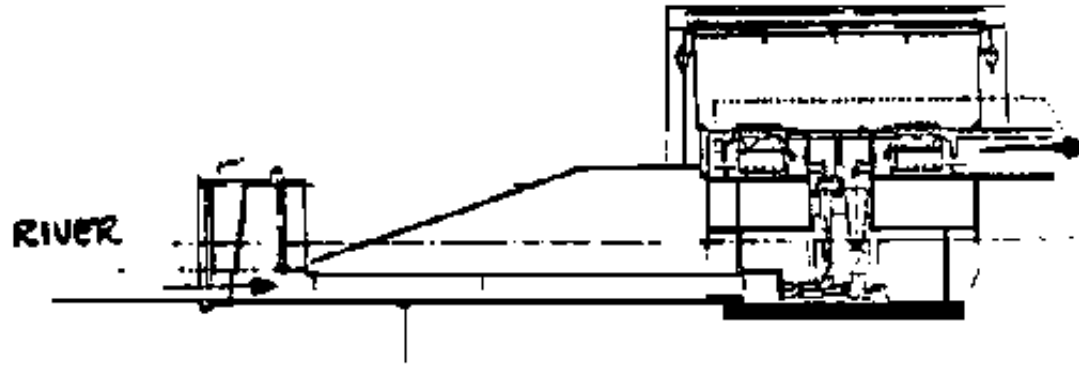


**Figure**

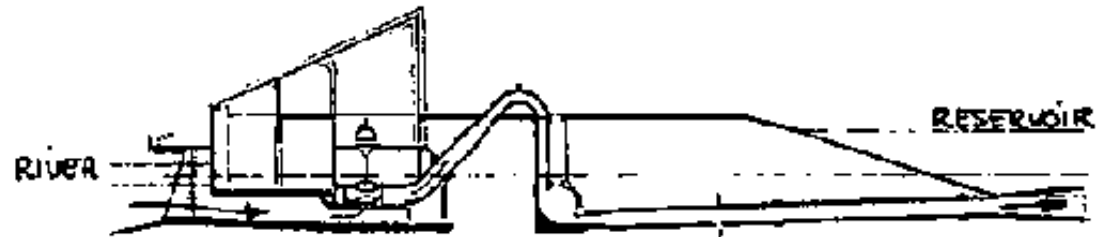
**Intake from a impounded reservoir or lake**



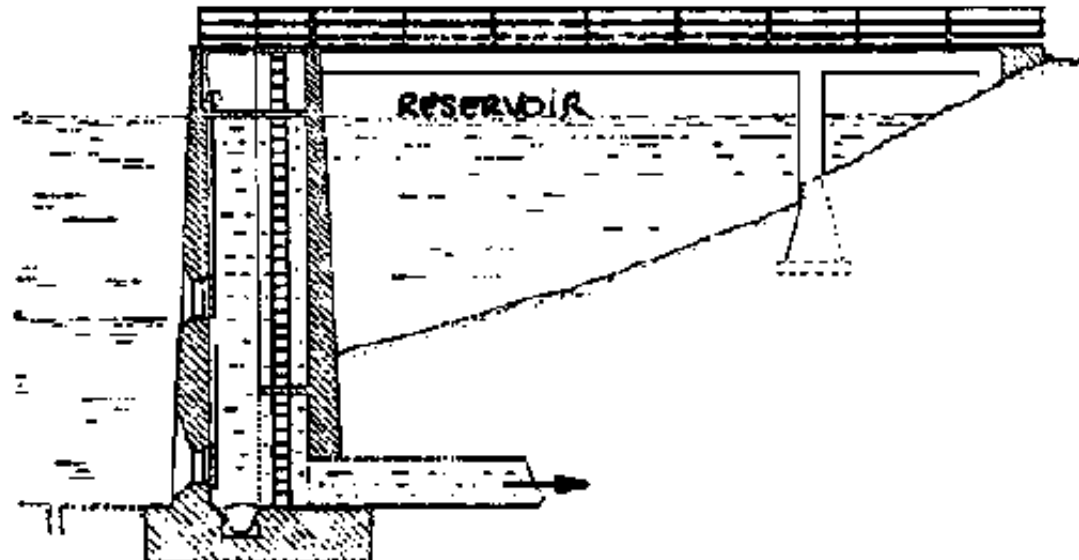
**Figure**



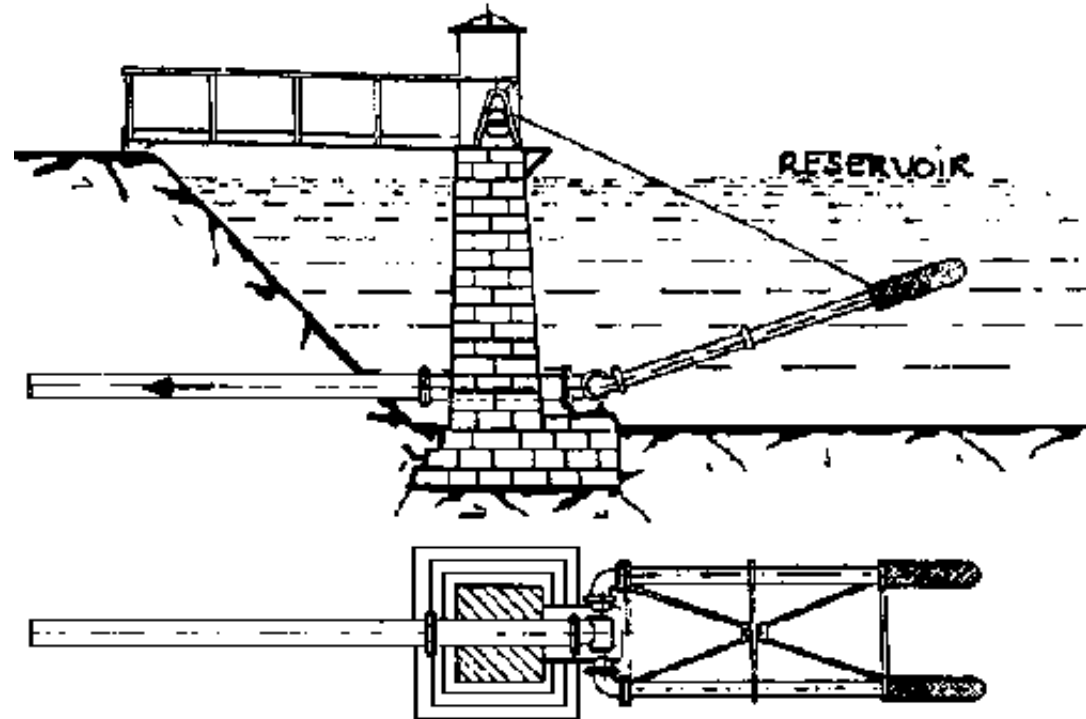
Figure



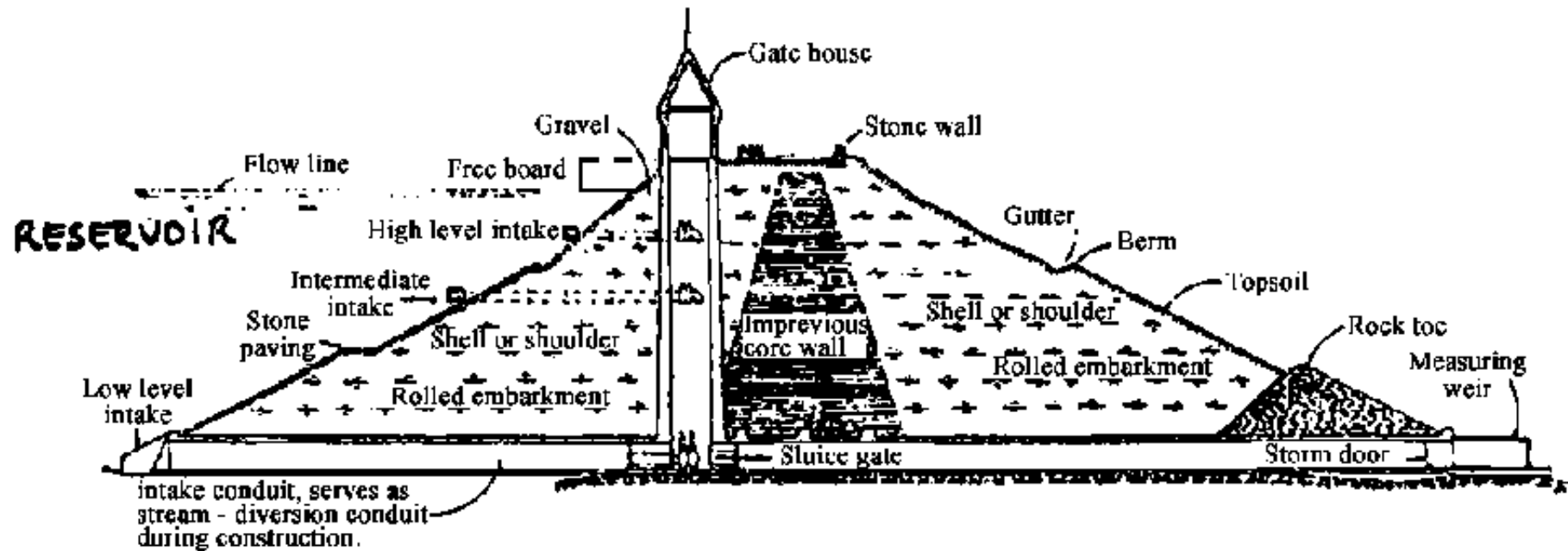
Figure



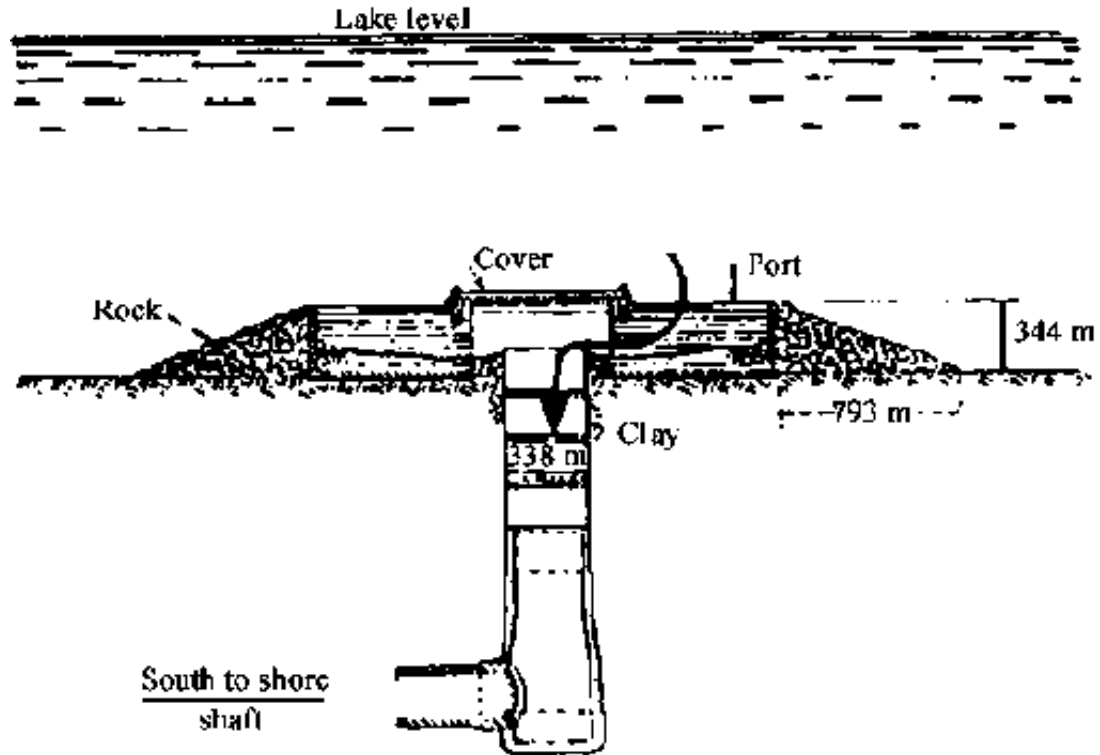
Intake tower.



**Water intake from reservoirs through hinged tubes.**

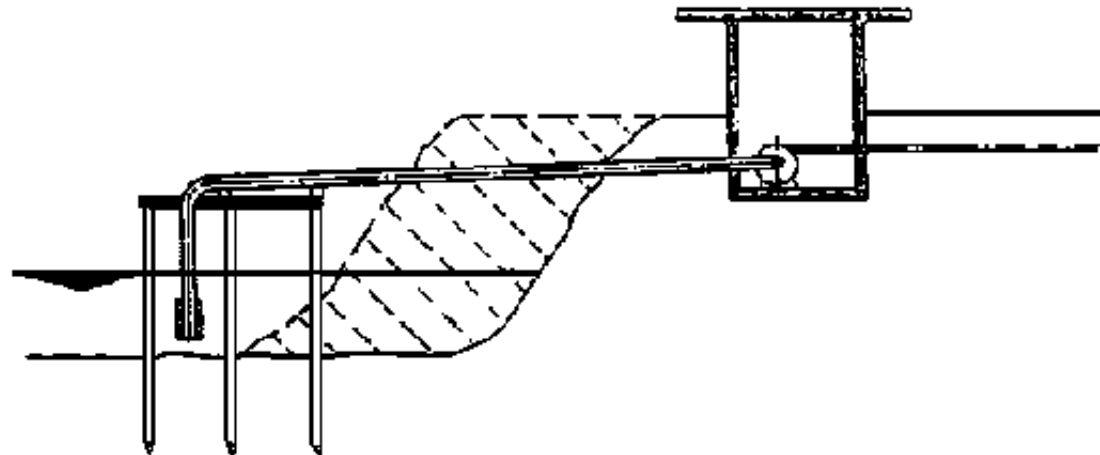


**Dam and intake tower for an impounded surface-water supply.**



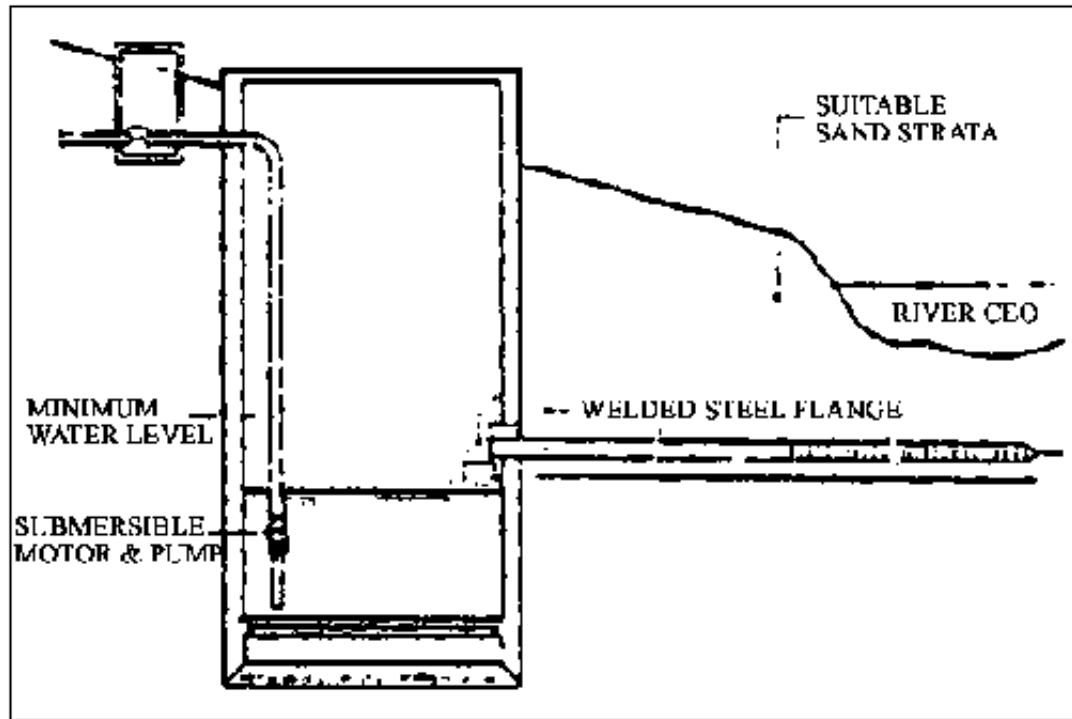
Figure

**Intake by means of river bed infiltration:**

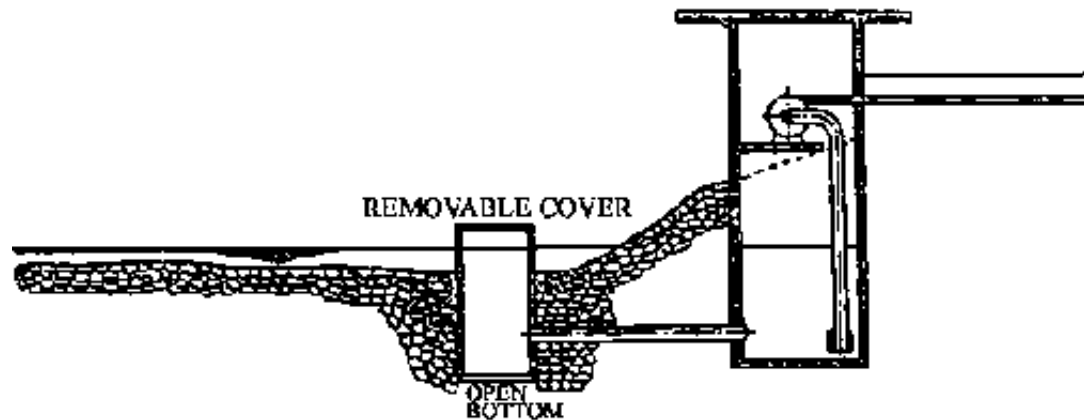




# Erosion of the embankment damaging the suction pipes.



**Bank river intake using infiltration drains.**



**Pumping station in embankment water abstraction in the river bed.**

## **2. Pumping stations**

### **2.1 Lay-out of pumping stations**

**For the lay-out of pumping stations no overall criteria can be formulated, as local conditions will be of great influence. Generally the lay-out will be the result of a design process in which all the foregoing design factors will be taken into account.**

**In general it can be said that the lay-out of a pumping station is a logic fit of all functions of the stations, with sufficient room to move between machinery for erection and maintenance purposes, but without unnecessary empty spaces nor in a horizontal plane, nor in vertical direction.**

**In principles, flow lines should be as short as possible and no unnecessary bends should be present in the piping.**

**Spaces that may be required are:**

- pump hall/engine room;**
- transformer station including high voltage switch gear;**
- low voltage switch gear, switch board, control desk, often combined and stores;**
- workshop and stores;**
- office, toilet (including water supply);**
- (central) heating and/or ventilation**
- generator room**

**All spaces should be well lighted. Also outside lighting may be required. Whether**

**a pumping station will include all these facilities will clearly depend on the importance of the plant and on its location.**

**The layout should be made in such a way the free movement of travelling cranes and crabs is not hampered by the presence of delivery pipelines or exhaust pipes of diesel engines. In principle the crane should be able to reach every part of the equipment, both for installation and maintenance or overhauling. The equipment will have to be moved to the workshop floor and/or to the entrance doors of the building.**

**Proper railings are required along stairs or on platform (catwalks) overlooking the engine room.**

**Flooring of the station should be such that it will not become slippery by oil leaks from equipment or by/grease lost during maintenance work.**

**Drainage openings should be provided for scrubbing.**

**The site lay-out of the grounds around the station should take care of sufficient access to the station, both for the erection and possibly removal!) of the mechanical equipment. Supply of fuel should be possible. Proper fencing will be required, especially in the case of automated stations.**

**If appropriate, sufficient space should be available for future extension of the station.**

## **2.2 Design procedure**

**In a normal design procedure several steps have to be taken in succession.**

**In the first step all relevant design criteria should be gathered. In the second step preliminary choices will have to be made as to the number and type of pumps to be used, the types of drives and transmissions and auxiliary equipment. Several of these possibilities will warrant further elaboration and sketches for a building will be made.**

**After a first evaluation of these first set-ups, one or more solutions will be worked out in more detail, resulting in one or more preliminary designs. These preliminary designs will have to be compared both on technical and on economical merits.**

**After a final choice has been made, in which also other factors may play a role, the definite design will be made.**

**On the basis of the definite design specifications can be written. Generally this will be done separately for the mechanical installations and the civil engineering constructions. In larger installations also the mechanical installations can be split up; e.g. separate specifications for electrical installations or specific items like mechanical trash-racks raking equipment, generator sets, etc.**

**On the basis of the specifications tenders can be invited from manufacturers and contractors. Especially for the mechanical installations specifications will have to be very clear in specifying required quality standards and performance requirements.**

**Of course, it will be possible to ask for offers on the basis of the design alone, without specifications. However, the great disadvantage of this procedure will be**

**that offers will be received that cannot be compared with respect to quality and performance. This procedure should therefore be discouraged.**

**After all tenders have been compared, contracts can be made between manufacturers, contractors and the commissioner, purchaser or principal.**

**After agreement on the contract has been reached (and under the assumption that financing has been arranged) manufacture of pumps can start and construction on the site can be initiated.**

**During manufacture and construction sufficient supervision will be required on the part of the principal. This supervision will not only deal with the actual construction of the station and the installation of the equipment, but it will often be necessary also to check the production of the mechanical equipment in the various factories.**

**Detailed drawings of the equipment will also have to be checked on behalf of the principal, before the actual production has started.**

**Finally, when the station becomes operational tests will have to be performed in order to check the performance of pumps, etc.**

**In the meantime the organization for the future operation and maintenance of the station must be created, sometime with the aid of the pump manufacturer, and/or a consultant.**

**The fore-mentioned procedure may be simplified for small pumping stations and/or when standard pumps plus drives are used from a reliable manufacturer.**

**However, also in this case the contract will have to be specific about quality standards, required performances, etc.**

**During all these design stages a good co-ordination is required between all disciplines involved in the design process. In principle this should be done by - or on behalf of - the commissioning agency or principal for the project. The coordination involves the timely preparation of drawings, production and shipment of equipment, the construction of the station and the installation of equipment on the site. In this respect the preparation of a time schedule - to which all participants in the construction (including the principal!) - will have to be bound is part of the co-ordination task.**

## **2.3 PUMPS**

**A pump is a mechanical device or machine and is used for lifting the water or any fluid to higher elevations or at higher pressure. The operation of lifting water or any fluid is called "pumping". Pumping may be adopted for the following purposes in the water supply scheme.**

- 1. To increase the water pressure at certain points in the distribution system**
- 2. To lift treated water to elevated storage tanks so that it may flow automatically under gravity into distribution system.**
- 3. To lift raw river or lake water to carry it to treatment plant**
- 4. To lift well water to elevated storage tanks.**

## **Classification of pumps**

### **Based on Principle of operation**

- (a) Air lift pumps**
- (b) Centrifugal pumps**
- (c) Displacement pumps**
- (d) Miscellaneous pumps**

### **Based on type of power required:**

- (a) Steam engine pumps**
- (b) Diesel engine pumps**
- (c) Electrically driven pumps**
- (d) Atomic power and other sources of power drive pump**

### **Based on type of service or on function**

- (a) Low lift pumps**
- (b) High lift pumps**
- (c) Deep well pumps**
- (d) Booster pumps**
- (e) Stand - by pumps**

**The most importance classification is in which mechanical principles of their working are involved and it is this classification which gives different types of pumps.**

## **Air lift Pumps**

**In this type of pumps compressed air is used to lift water. These pumps are used principally in well pumping, but they are also used for handling thin sludges in sewage treatment processes.**

## **Centrifugal pumps**

**If a vessel having liquid in it, is rotated about a point centrifugal force will cause the liquid level to rise to a point by  $h = \frac{v^2}{2g}$ . The open impeller type is better, suited to pumping liquid which carry solids such as sewage or muddy water, but the enclosed impeller is generally more efficient in operations and is therefore, more after used in water supply.**

## **Displacement pump**

### **(a) Reciprocating pumps**

**Because the discharge through the pump is not continuous reciprocating pumps may be used only where heads are very high and where the capacity required is great enough to justify the more expansive types.**

### **(b) Rotary pumps**

**In this type of pump there are two cams or gears which mesh together and rotate in opposite direction. Its capacity depends upon the size and shape of the cams or gears.**



## **Miscellaneous pumps**

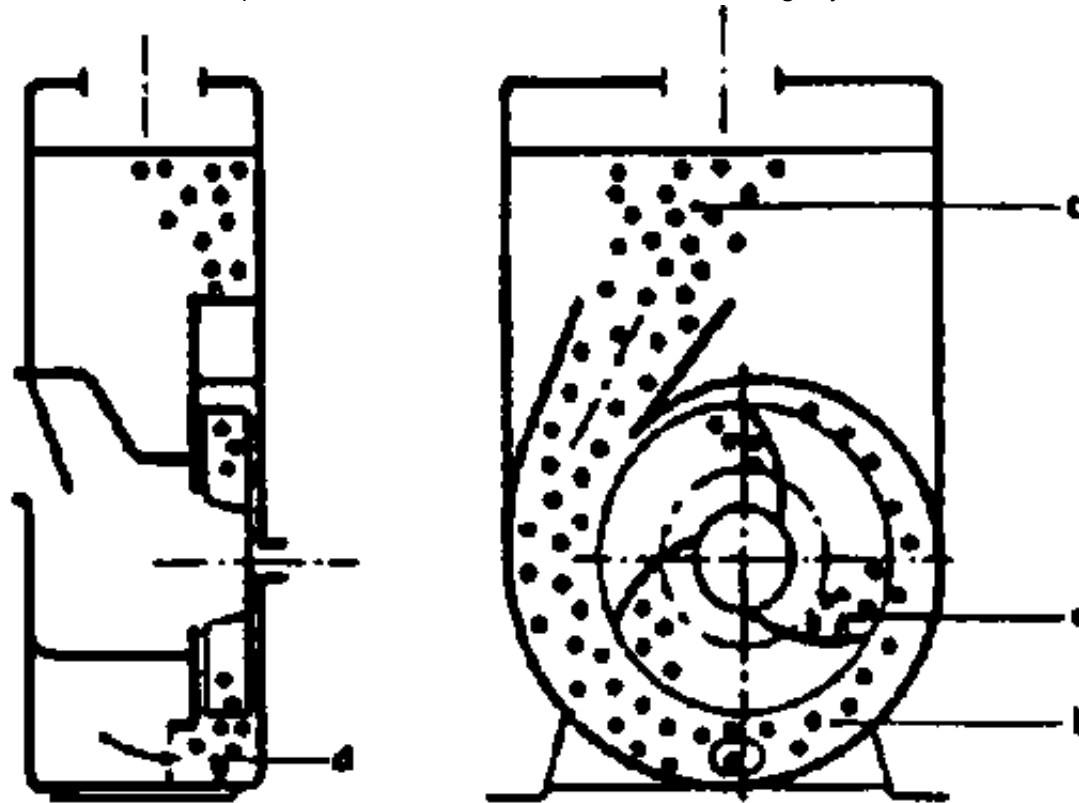
**(i) Hydraulic ram**

**(ii) Jet pump**

**This pump is a centrifugal pump with the driving motor in the well which is fitted just below the impellers.**

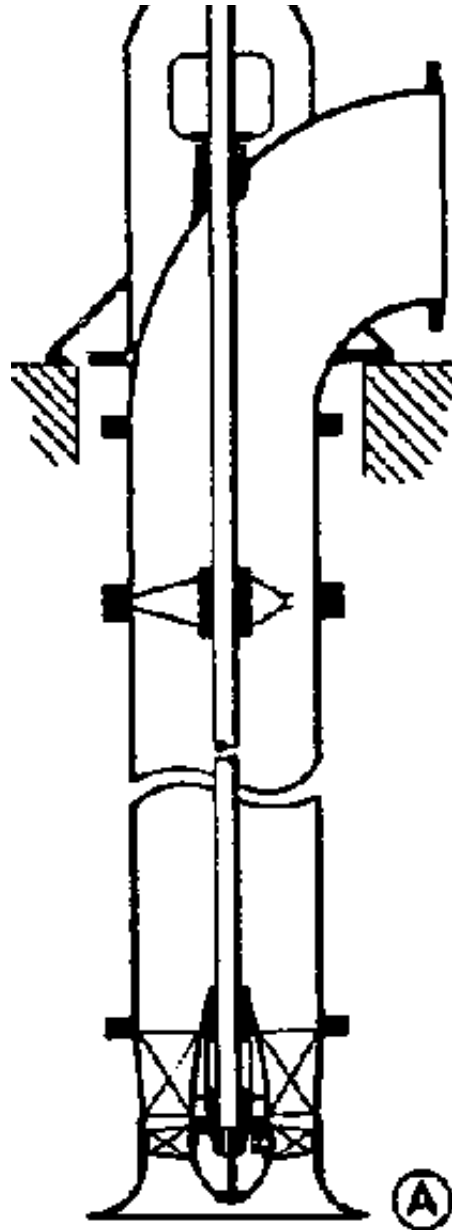
### **Hand Pump**

**These are the pumps which can be installed to lift water from shallow wells in small quantities required only for household uses.**

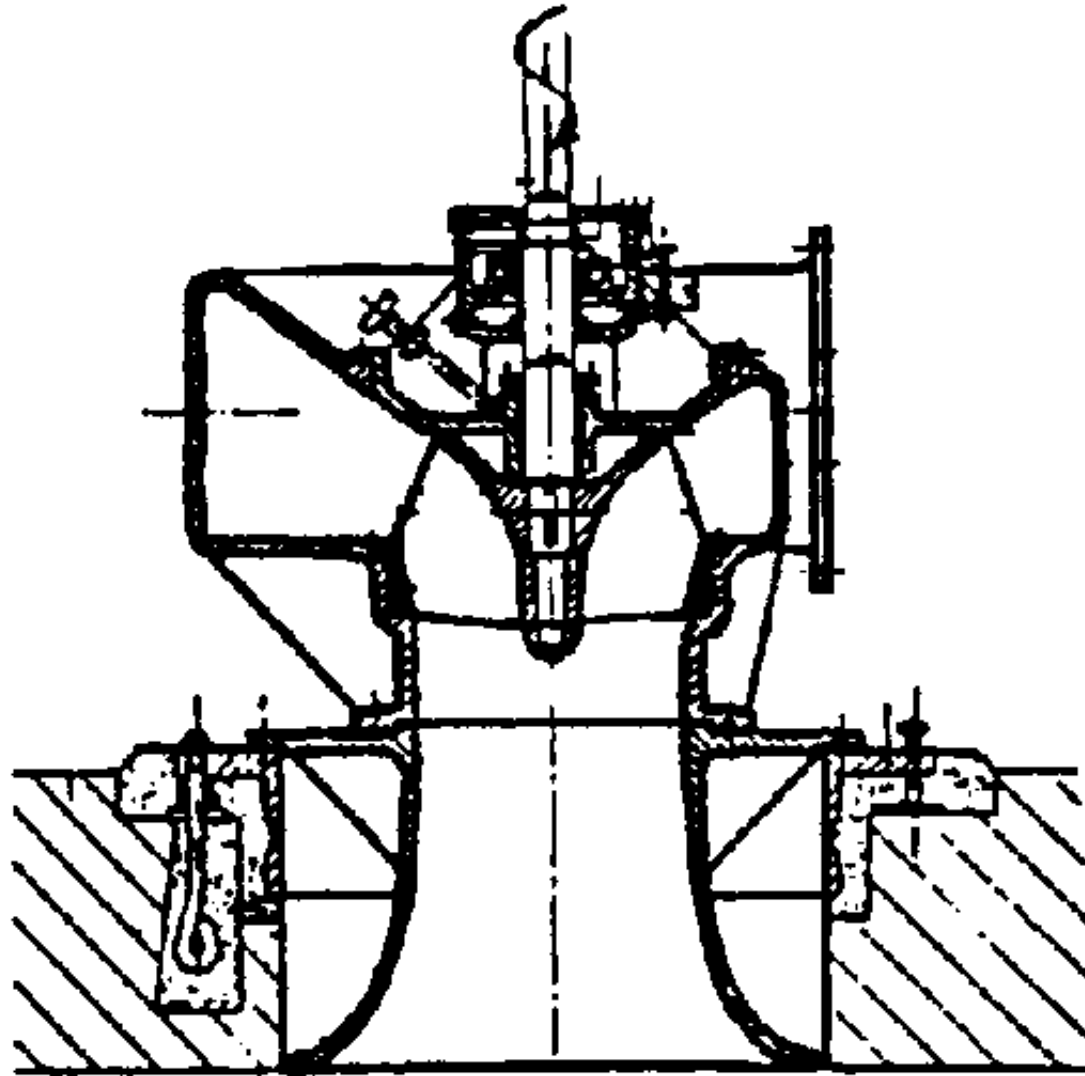


**Fig. 21a - Selfpriming centrifugal pump**

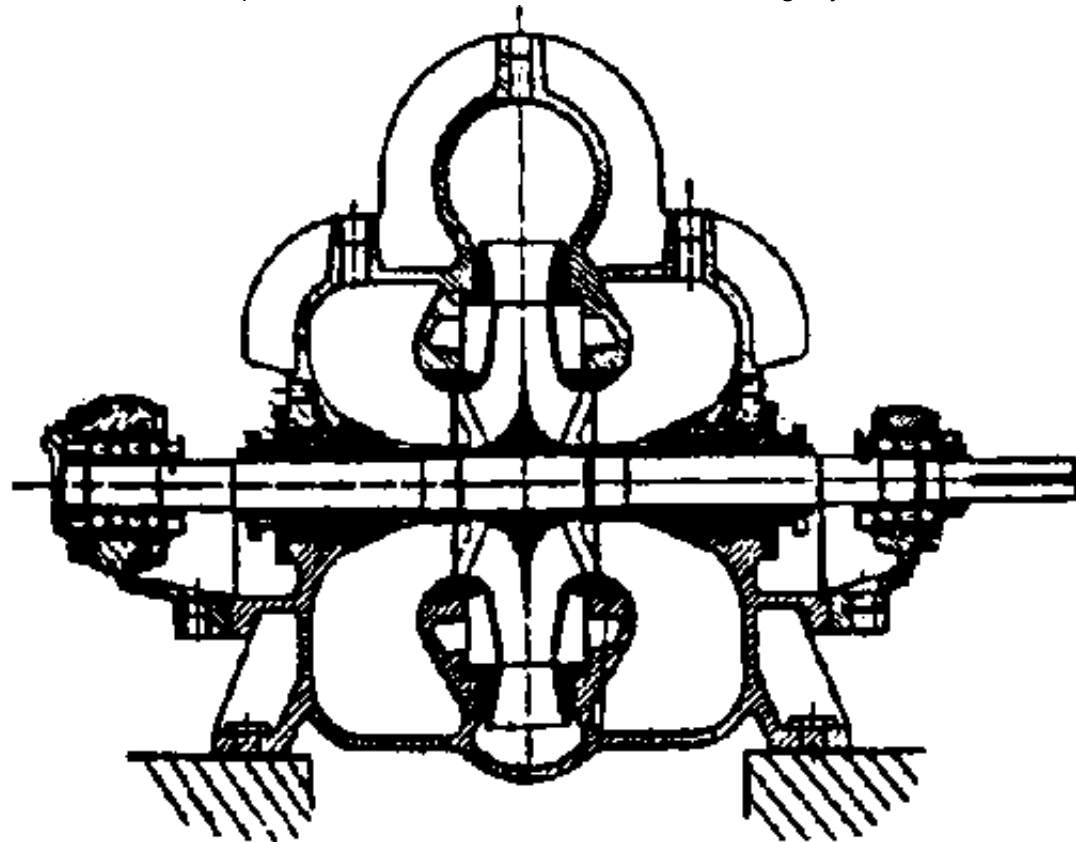




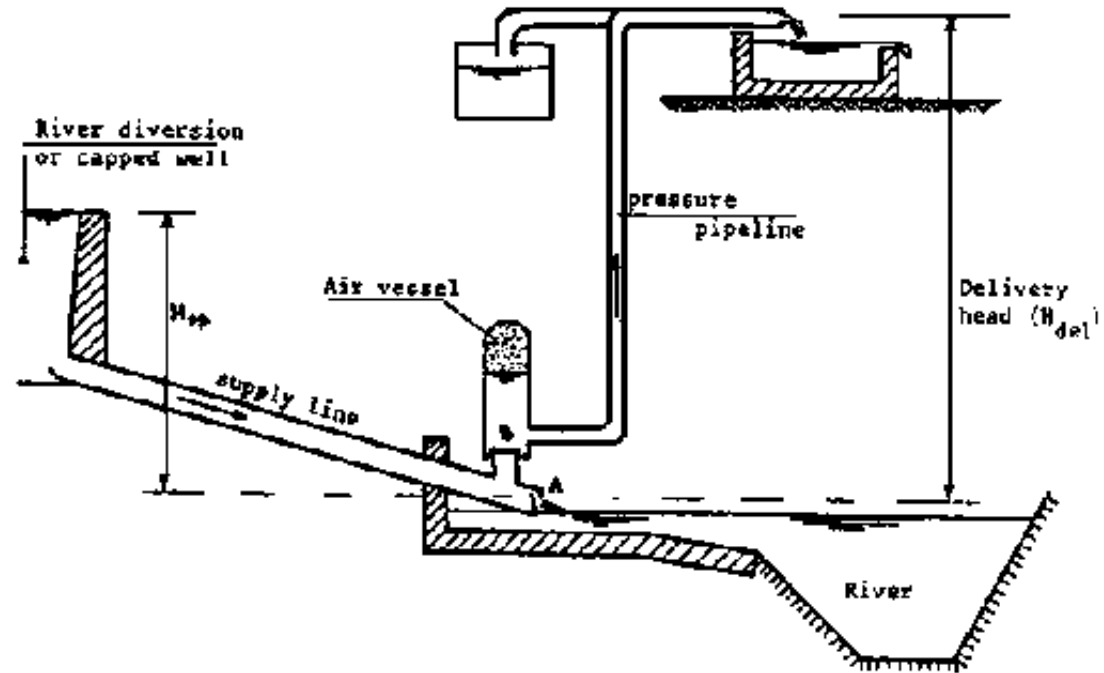
**Fig. 22 - Propellor pump**



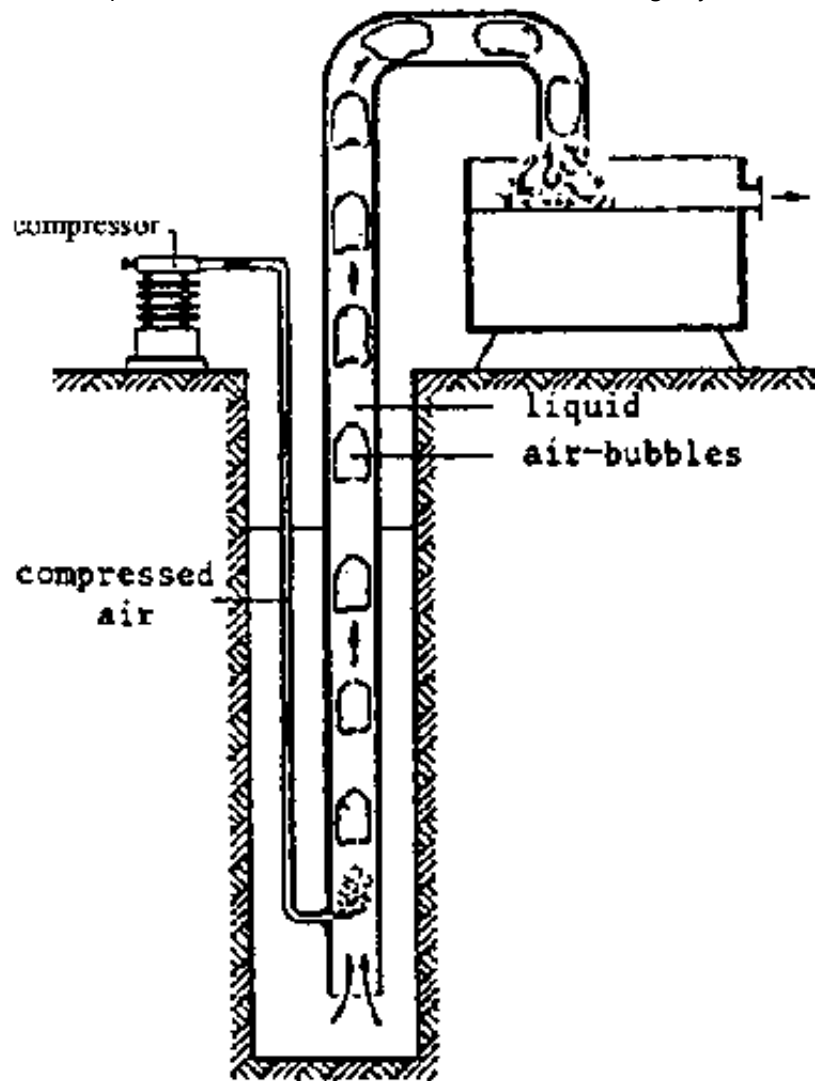
**Fig. 23 - Mixed-flow pump**



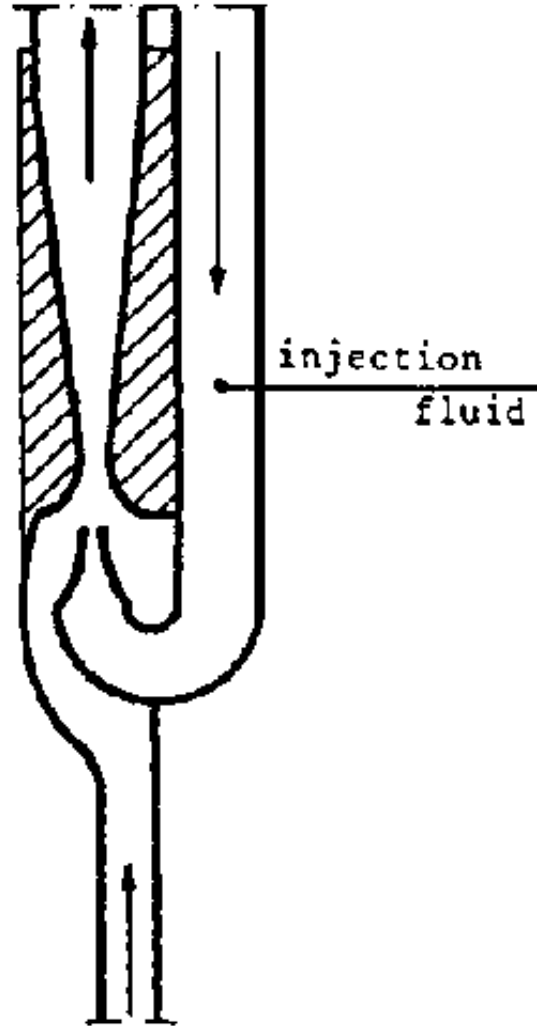
**Fig. 24 - Centrifugal pump with double inflow**



**Fig. 16 - Hydraulic ram**

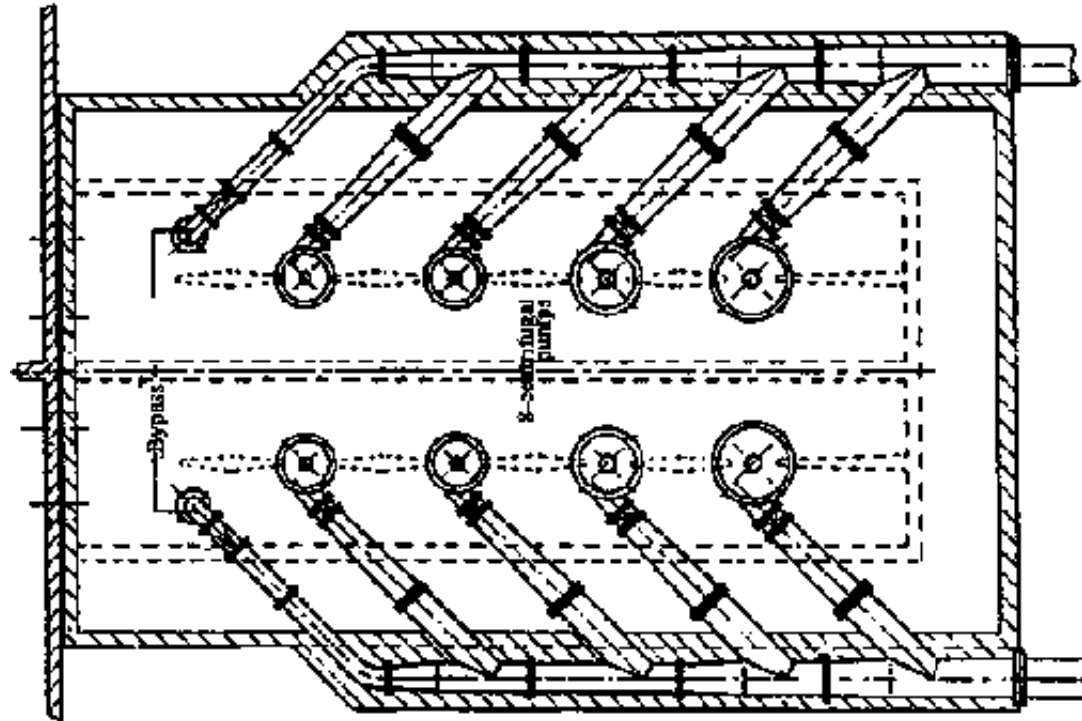


**Fig. 17 - Air lift**

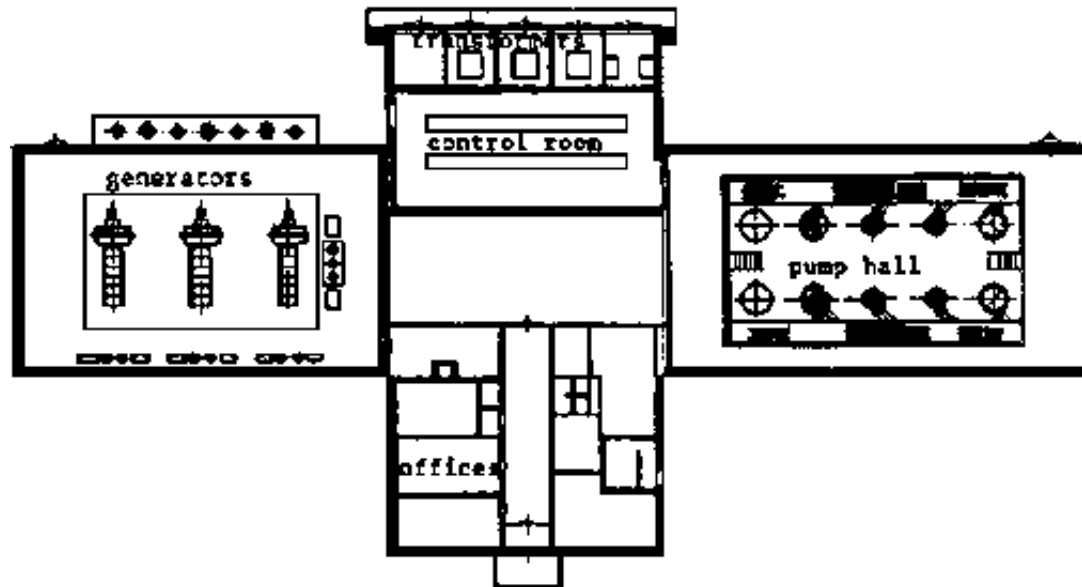


**Fig. 18 - Injection pump (Jet pump)**





**Fig. 107 - Lay-out of water distribution station**



## **Fig. 108 - Electrically driven distribution station including emergency/peakload generators**

### **3. Rising main**

#### **General guide lines**

**The rising main should be as far as possible be laid with an even gradient with a minimum of sharp bends and curves. It should be laid in a trench with a minimum of 0.6m of earth cover, and if brought above ground for any reason should be held firmly by clamps to concrete blocks. It may be necessary, where pressures are high to anchor the pipe at bends' even if under the ground, and again this is usually done by means of concrete blocks.**

**In the trench the pipe should be supported along its barrel and not on its joints. This means deeper excavation at every joint, sufficient only to have the bottom of the joint not resting on the trench bottom. In rocky trench it is advisable to lay the pipe on prepared bed of sand.**

**A wash-out valve is inserted in the rising main immediately outside the pump house with a stop valve or non-return valve immediately downstream of it, to prevent the wash water flowing back to the pump. A non-return valve or reflux valve is better than a stop valve as it cannot be inadvertently left closed when the pump starts up again. Unless the rising main is a long one, it will seldom be necessary to incorporate an air-valve and only in exceptional conditions should this be done for a short rising main.**

**It is also bad practice to take off connections direct from the rising main, and**

**generally the rising main should convey the water direct from the pump to the high-level storage tank without being tapped or having water drawn off in any way. It may be necessary in certain circumstances e.g. where the rising main passes close to an isolated house which is a long distance from the storage tank and which would require a every expensive gravity pipe back from the tank to supply it. In these cases care should be taken that the connection feeds a storage tank with a ball valve and doesn't discharge freely at the end.**

**The diameter of the rising main should be such as to keep the velocity of the water fairly low, and consequently the head lost in friction. A speed of up to 1.5 m/sec. should not be exceeded, and if it is, a thought should be given to installing a larger diameter pipe, balancing this against lower friction head and small pumping units.**

#### **4. Water treatment**

##### **General guide lines**

**Water treatment involves physical, chemical, bacteriological and biological transformation of raw water into potable quality. The quality of water for use is controlled by world Health Organisations standards or Tanzania temporary standards.**

**Design of water treatment plant requires the information given below:**

- the water demand: the treatment works should be designed for the peak day demand.**
- The raw water quality: It is required to decide the type of treatment.**

## **The following methods of water treatment are considered to be suitable for Tanzania.**

- Screening or straining**
- Plain sedimentation**
- Chemical coagulation, flocculation and settling**
- Filtration**
- Disinfection**
- Control of algae**
- Taste and odour control**
- Softening**
- Removal of iron and manganese**
- Defluoridation of water**

**Based on the life span of the different structures the following recommendations are made:-**

- Pumps, steel tanks, mechanical and electrical equipment and internal piping have to be designed for the future demand of 15 years.**
- All other structures have to be designed for the future demand of 20 years ahead.**

## **Water Quality Standards used in Tanzania**

**Domestic water supplied to the community should be free from particles and pathogens hazardous to human being and livestock lives, taste, colour and odour should be kept at low limits; to attain the quality; two notable set of standards are**

## used in Tanzania.

**The standards are mostly applied to Urban Water Supplies and large rural water supplies. The temporary water quality standards for domestic water supply in Tanzania are applied to small rural water supply.**

No	Name of Constituent	Symbol	Unit	International Standards WHO 1963	Tanzania Standards for Rural W/S-1974
1	Fluoride	F	Mg/l	1.50	8.00
2	Colour		Mg/l	50.00	50.00
3	Turbidity		Mg/l	25.00	30.00
4	pH			6.5 - 9.2	6.5 - 9.2
5	Calcium	Ca	Mg/l	200	Not mentioned
6	Magnesium	mg	Mg/l	150	Not mentioned
7	Chloride	Cl	Mg/l	600	800
8	PV	02	Mg/l	10.00	20.00

**The International Standards of Quality of Domestic water has to types of criteria, these being acceptable and allowable. In the table, only allowable values are shown. The international standards apply to water distributed through water sources or systems serving cities, municipalities and townships - water supplies. Furthermore, they apply to those water systems serving rural population of more than 5000 people - large scale rural water supplies; and lastly all those water systems which have treatment system more complex than simple sedimentation and or rapid filtration appliances.**

## **5. Gravity main**

**A gravity main is of course the most preferable in respect of economy in construction, operation and maintenance. The main shall always be of such a size that the total quantity required for the future projected peak day demand is able to flow through the pipe in 24 hours.**

**The gravity main should be as far as possible on a constant falling gradient, avoiding high points and low valleys. Where the static pressure exceeds the allowable pipe pressures a break pressure tank with ball valve should be installed. Excessive high points should be avoided and at no account should the pipeline be laid higher than the hydraulic gradient (negative pressure).**

**Where it is unavoidable, for the pipeline to be laid above ground the pipe need to be fixed freely on concrete supports and held in place by metal ring brackets which are set into the concrete support. The pipe need to have free movement within the ring bracket. Pipes above ground can only be of galvanized steel or ductile iron. The pillars should be placed at length of the pipe.**

**Concrete anchors should be constructed at every 200m on all gradients and at much lesser distances in steep gradients and still lesser distances in steeper gradients. Also anchors should be provided at all horizontal and vertical changes of direction, at all equal tees and at all valves. The concrete should be formed so that it follows the curvature of the pipe. Suitable air valves should be located at all high points fitted with stop valves. Even in flat areas an air valve at every 1000m. is preferable. At all low points wash out arrangements should be positioned. These did not to be the same diameter as the main.**

**Non return or reflux valves can be located at distance of 3 to 5km. to facilitate maintenance and repair and in addition will help in reducing water hammer. For the purpose of inspection, maintenance and replacements unions or flanged joints should be provided every 350 to 500m in all pipelines.**

**Pipe should be prepared in well prepared trenches, 0.6m wide by 0.75m. deep, for pipes up to 100mm; and 0.8m wide by 1.0m deep for bigger pipes. The pipe should be laid on a prepared level bed cushion of sand or soil, free of stones under the pipe. Also all the back fill material should be free of stones around the pipe.**

**Special case should be taken to where mains are crossing roads and tracks, where a minimum of 1m. cover should be provided. It is an advantage when the pipes can be laid inside a bigger diameter steel, D1 or C1 pipe. These covers and protections should be extend 3m. beyond the width of the road at either sides.**

**The gravity mains are so designed that the available pressure head is just lost in overcoming the frictional resistance to the flow of water. The velocity to be generated are therefore so maintained that they are, neither too small to require a large size diameter pipe; nor too high to cause excessive loss of pressure and head.**

## **6. Water tanks**

**Water tanks are provided for the purpose of balancing the constant supply rate from the water source or treatment plant with the fluctuating water demand in the distribution area. The storage volume should be large enough to accommodate the cummulative differences between water supply and demand and in case of**

**breakdowns between source and tanks. If there would be no storage of water in the distribution areas, the source of supply and the treatment plant would have to be able to follow all fluctuations of the water demand of the community served. This is generally not economical and sometimes not even technically feasible. For that purpose, a water tank is provided. It also helps to maintain adequate pressure in the distribution.**

**Storage tanks may be classified in the following way:-**

**(i) classification based on the position of the tank. Under this category of classification the tanks may be;**

- (a) surface storage tanks**
- (b) elevated storage tanks**

**(ii) Classification based upon the material of construction.**

- (a) R.C.C. tanks**
- (b) Masonry tanks**
- (c) Concrete tanks**
- (d) Steel tanks**

**(iii) Classification based on the shape of the tank.**

- (a) Circular tanks**
- (b) Rectangular tanks**
- (c) Intze tanks**



## **Calculating capacity of the reservoir or tanks.**

**The total capacity of the reservoir can be divided into three categories. The total of all the three categories determines the storage capacity of the reservoir.**

### **(a) Balancing reserve**

**Demand of water always keeps on varying hour to hour but, treated water always comes out of treatment plants at a constant rate. Balancing reserve is that quantity of water required to be stored for balancing the variable demand in the distribution system. It is mostly calculated by means of mass curve or hydrographs.**

### **(b) Break-down reserve.**

**This storage is estimated to be 1½ to 2 hours of average daily supply.**

### **(c) Fire reserve = (F C) T**

**Where:**

**F = Fire demand**

**C = Reserve for pumping capacity**

**T = fire duration (10 hours) and (2-5) hour**

## **7. Distribution system**

**After having treated the raw water in water treatment plants, to the required**

**standards, the last and final stage of water supply schemes comprises distribution of water to the consumers. The main purpose of the distribution systems is to develop adequate water pressure at various points i.e. depends upon the topography of the area of distribution and its elevation with respect to the location of the water treatment plants. The distribution system may be classified into three categories.**

- (i) Gravity system**
- (ii) Pumping system without storage**
- (iii) Dual system with storage**

**Water from storage tanks can be distributed to consumers by arranging pipelines in two ways.**

**(i) Dead-end System (Branches system)**

**In this system water is fed into secondary pipes from one side**

**Advantages**

- (a) It is possible to calculate accurately the discharge and pressure at any point in the distribution system. Calculations are simple and easy to do.**
- (b) This method requires comparatively less number of cut off valves, hence cheap.**
- (c) Pipe lines can be laid in the street of any pattern which may not be standardised.**

**(d) The diameter of mains are to be designed for the population they have to serve. This fact may make the system cheap and economical.**

### **Disadvantages**

**(a) During break downs and repairs large areas which are served by this pipe, go without water and thus cause great inconvenience to the public.**

**(b) In this system there are large number of dead ends, where water does not circulate but remains static, which may get contaminated due to stagnation.**

**(c) Water available for fire fighting will be limited is being supplied by only one water main.**

### **(ii) Grid-iron System (looped system)**

**In this system, water is fed into secondary pipes from two sides.**

#### **Advantages:**

**(a) At the time of repair or breakdown only small portion of the distribution layout is affected.**

**(b) As there are no dead ends and water circulation is free throughout, it is not liable to contamination.**

**(c) Water reaches all the points with minimum loss of head.**

**(d) At the time of fires, by manipulating the cut off valve, plenty of water supply may be diverted and concentrated for fire fighting.**

### **Disadvantages**

**(a) Cost of pipe laying is more because relatively more length of pipe is required.**

**(b) It is difficult to calculate pressures and discharges at various points of distribution systems**

**(c) More number of valves are required.**

## **8. The design of the sewerage system**

### **8.1 Energy concept**

**Before starting the design, consideration should be given to the energy concept of a sewerage. The aim of our system is to transport sewage from any part of the town, or area to be seweraged, to a predetermined point where it is going to be treated or discharged into the surface water. To transport water from one point to another, energy is needed. This energy is available in the form of potential energy, provided the point the water enters the system is higher in level than the point where it is discharged. The lost potential energy is equal to the wall friction in the sewer, multiplied by the distance the sewage has traveled. Knowing that the friction is proportional to the square of the velocity, we see that in flat areas we have to be thrifty with energy and design our sewers to operate with the minimum allowable velocity. Nevertheless, if insufficient energy is available, an additional supply could be provided by means of pumping. When more than the minimum**

**requirement of energy is available, we can allow a higher flow velocity. If it occurs that the maximum allowable flow velocity does not utilize all of the available energy, then the surplus has to be dissipated, for instance, by adopting drop manholes. According to these considerations, it can be concluded that, especially in flat areas, the utmost care must be taken not to lose energy unnecessarily. This means that turbulence and considerable fluctuations of flow velocities in the sewer system have to be avoided, manholes and bends have to be streamlined, no application of drop manholes, overflows have to be designed with a minimum of energy loss for DWF and transitions have to be designed properly.**

## **8.2 Layout**

**The first step is to design the layout. It is not possible to follow a fixed procedure. In general, an attempt should be made to follow the natural drainage pattern. It is advisable to work from the overall plan to the details. First, the border lines of the area to be sewered (catchment area), the watersheds and the main valleys have to be marked on a map. Afterwards the sewer lines have to be arranged tentatively to fit the most economical flow pattern and the main sewer line in the area has to be determined. It has to be kept in mind that the shortest way always has to be chosen. Figures 6 give some examples of flow patterns.**

**Some general rules to follow during the design of the layout are:**

- (a) No sewer should pass underneath a building**
- (b) Avoid crossings with railroads, canals, rivers etc.**
- (c) Manholes have to be plotted at all junctions and changes of slope or**

**direction. The maximum manhole distance should be 35 to 50 meters. Between manholes a sewer has to be straight. From these manholes, the sewer can be inspected to locate obstructions and cleansing device with buckets and steel cable can be passed through them. This is not possible in the case of curved sewers. These have to be used sometimes in winding and narrow streets.**

**(d) Big accessible sewers may be curved and have manholes at 100 to 200 meter intervals.**

**(e) The locations of the sewer depends on the type of sewer and the width of the street.**

**Now, on the layout, the sites for the pumping stations, the storm water overflows and the treatment plants can be indicated.**

### **8.3 Calculations**

**By having this complete layout, and by knowing the population at the end of the design period, the sewage production and storm water flow and by the whole system can be calculated. Normally this is done with the aid of a computation list. The procedure is as follows:**

**(a) Mark the border lines of the community or the catchment area of the main sewer in that area, including future extension areas to be connected;**

**(b) Mark the internal border lines of the tributary areas for every computation section of the sewer lines. This includes the partial tributary**

**areas along the main sewer as well as the tributary areas which are connected through secondary sewers to the main sewer. These areas form the flow pattern for the domestic and industrial waste water as well as the storm water.**

**Find the surface of each area by planimetry and multiply this value with the runoff coefficient of that particular area (average reduction factor at the end of the design period) to find the surface of the reduced tributary area;**

**(c) Compute the tributary population by multiplying the surface of the area with the population density;**

**(d) Find the total average and total maximum dry weather flow (DWF) - domestic flow, industrial flow, including infiltration water;**

**(e) Estimate the concentration time at the section under consideration, and compute the total storm flow (RWF);**

**(f) Find the maximum combined flow in case of a combined sewerage system;**

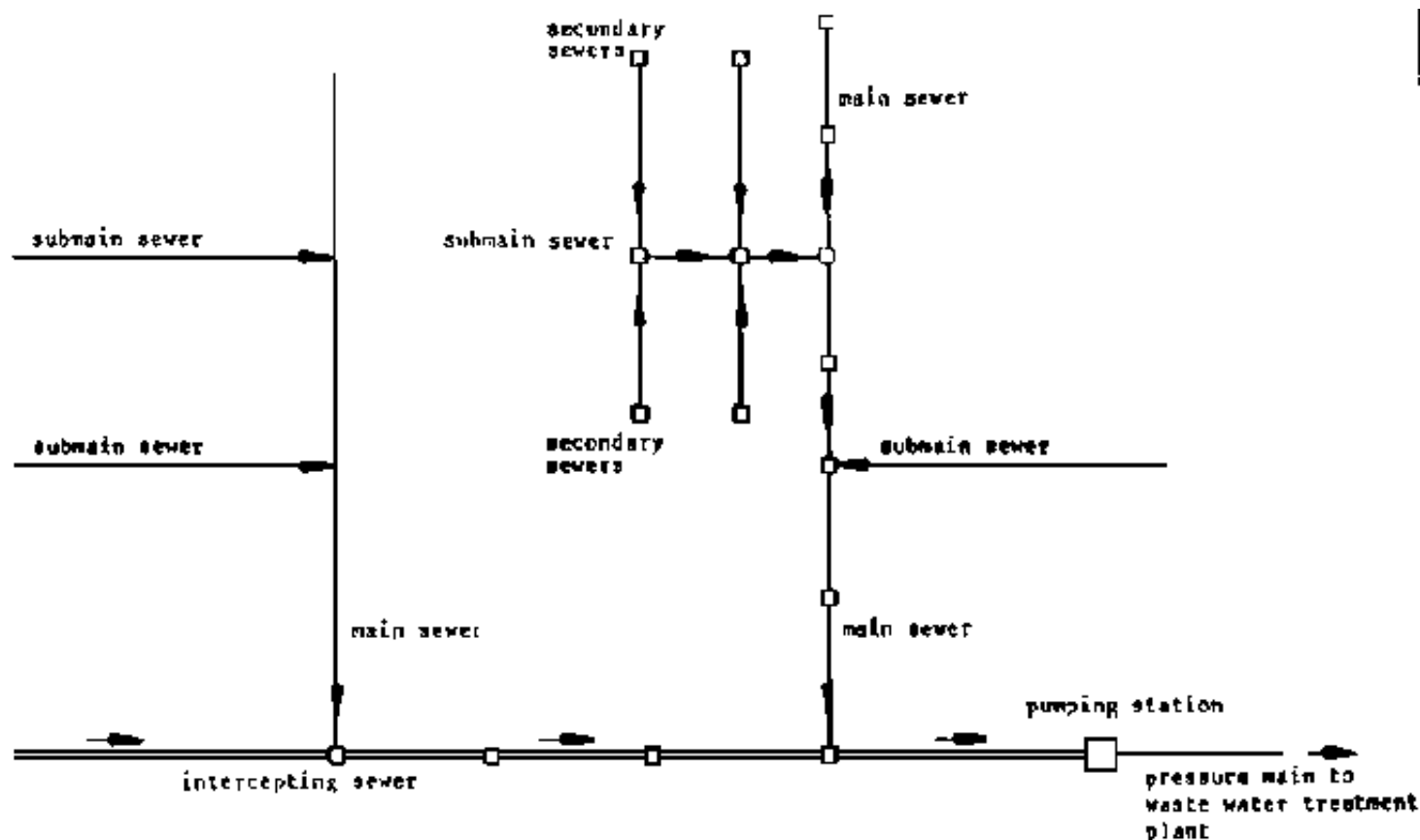
**(g) Determine the elevation and slope of the invert; choose diameter of sewer and find capacity and flow velocity when flowing full. Minimum sewer sizes are: 0.15m for house connection; 0.20m. for sanitary sewers, 0.30m for storm sewers.**

**(h) Compute flow data for actual sewage flow and storm flow or sewage flow and combined flow (combined system). Check estimated flow time**

**with actual flow time; correct if necessary.**

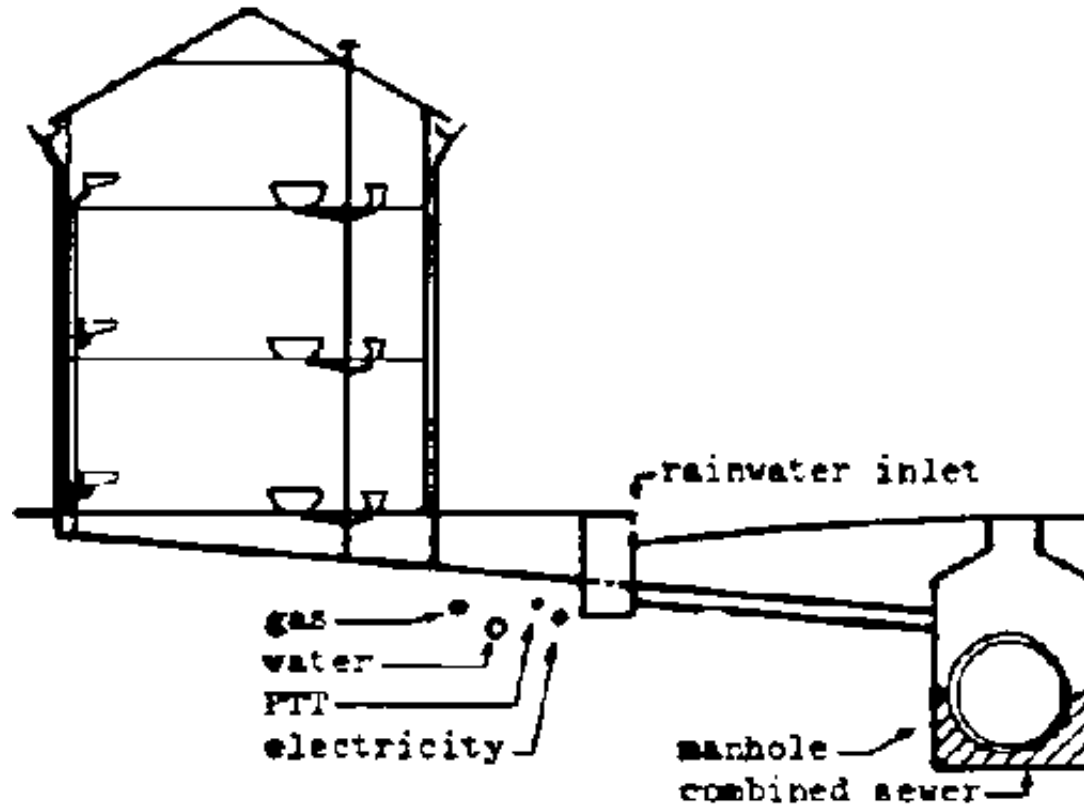
**(i) Design and calculate structures such as overflows, pumping stations, retention basins etc.**

**In case of a sanitary sewer or a storm sewer has to be designed the same computation list can be employed, by merely deleting the redundant columns. As an example a typical layout schemes of a waste water collection system has been attached below**

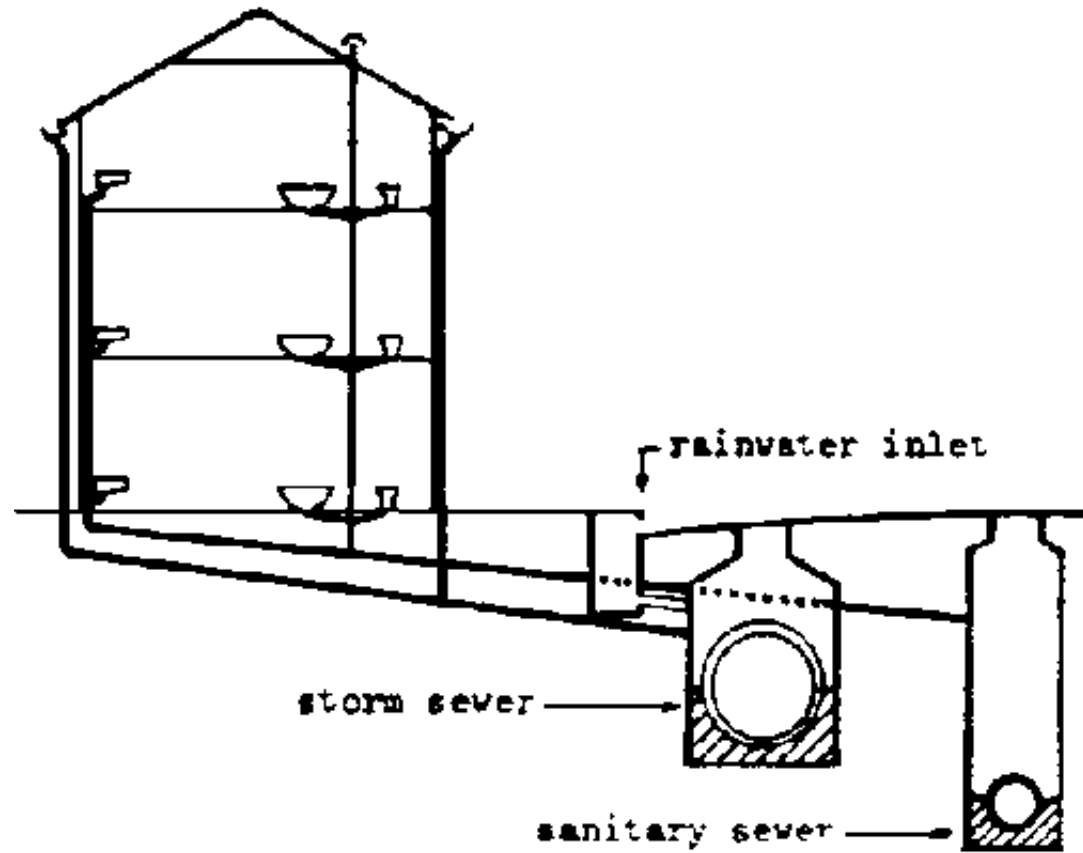


**Fig. 1. Typical lay-out scheme of a waste water collection system**

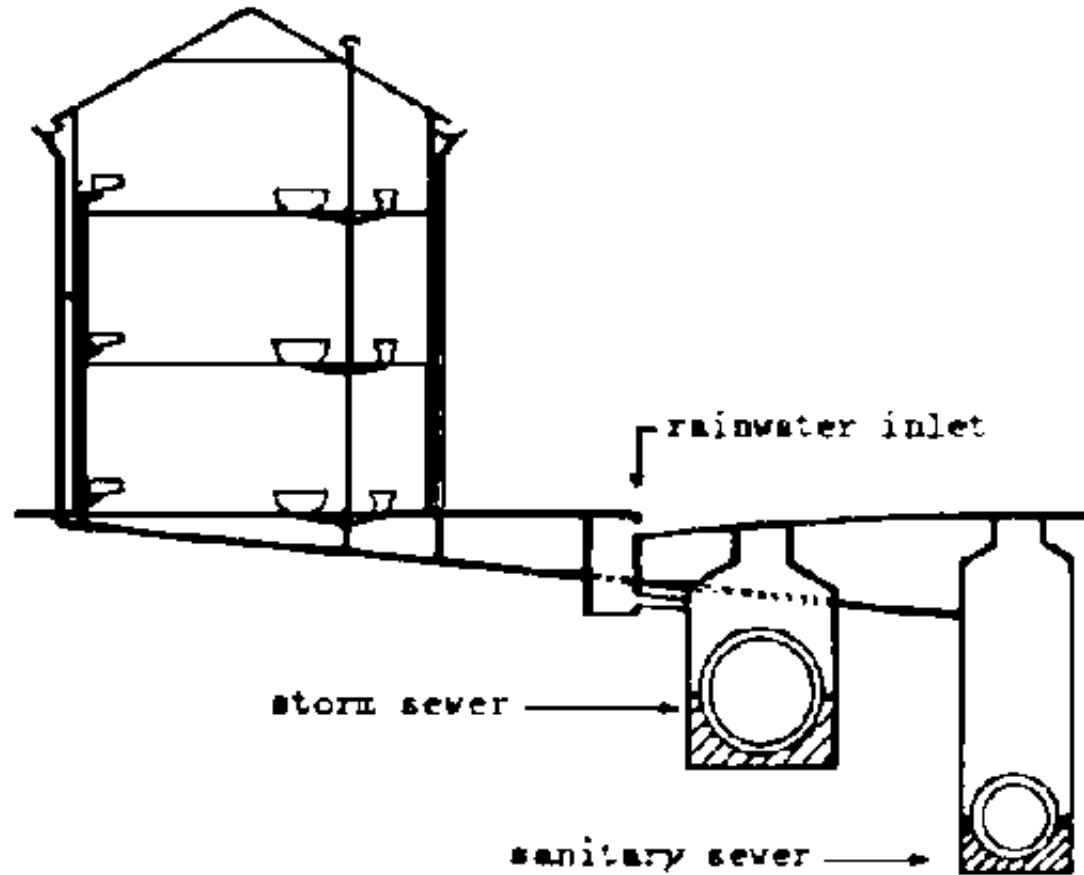




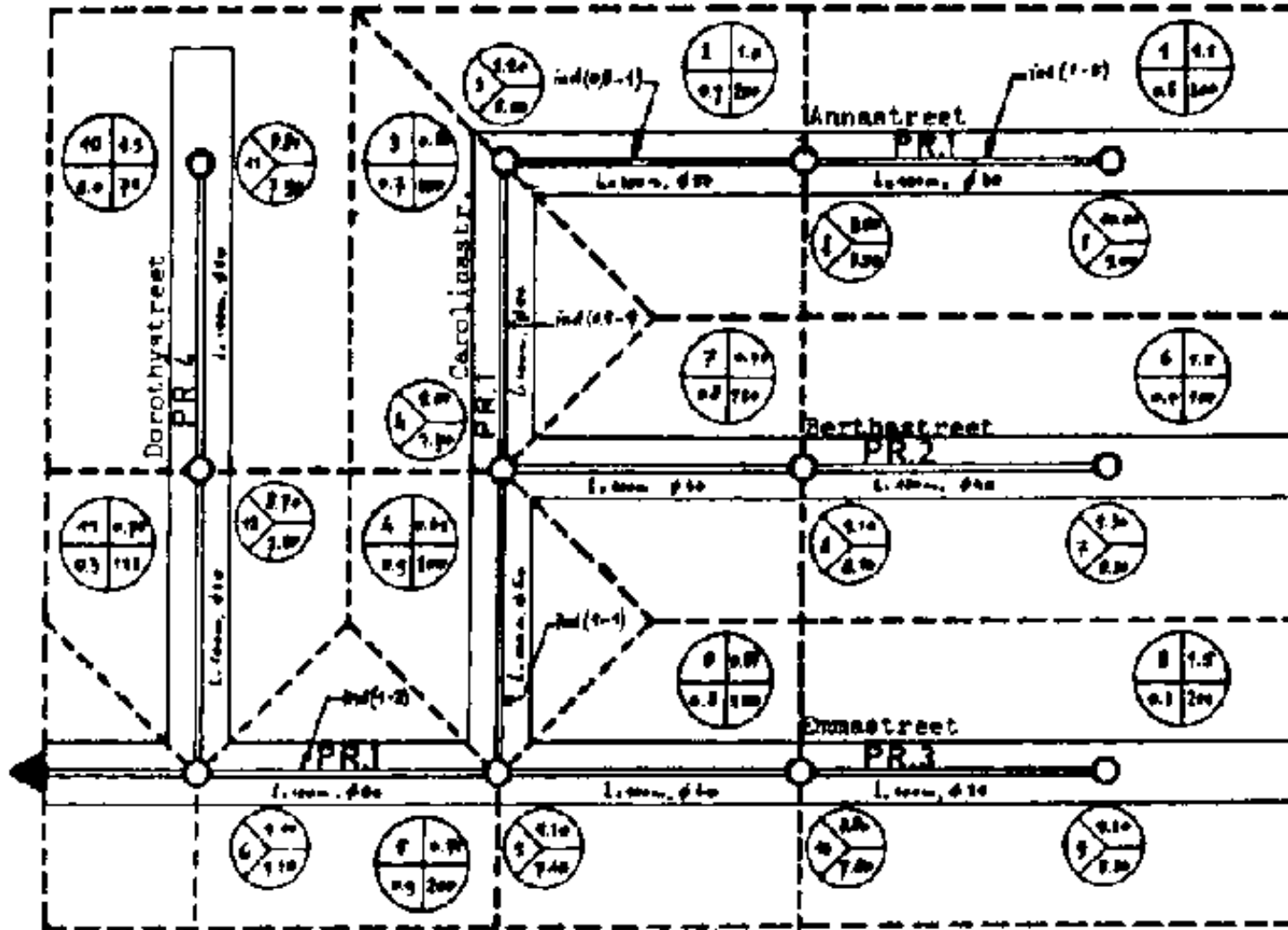
**Fig. 2. Combined system**



**Fig. 3. Separate system**



**Fig. 4. Pseudo separate or partially separate system**



TOWN A, Extension B

ind(a-b) = industrial water  
 a = average flow  
 b = peak flow



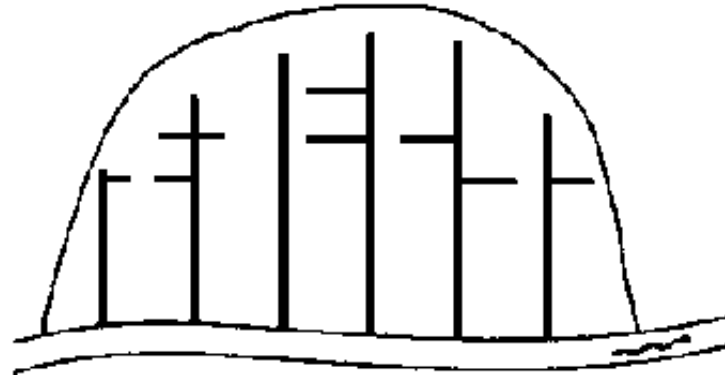
A = nr. of area  
 B = surface of area  
 C = runoff coefficient  
 D = population density



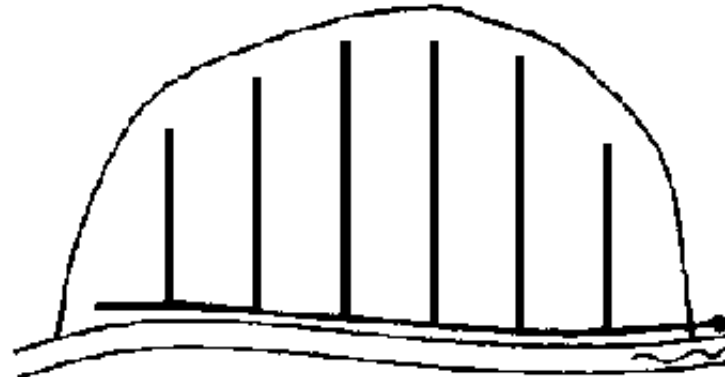
E = nr. of manhole  
 F = ground level  
 G = invert level

Fig 5. Layout

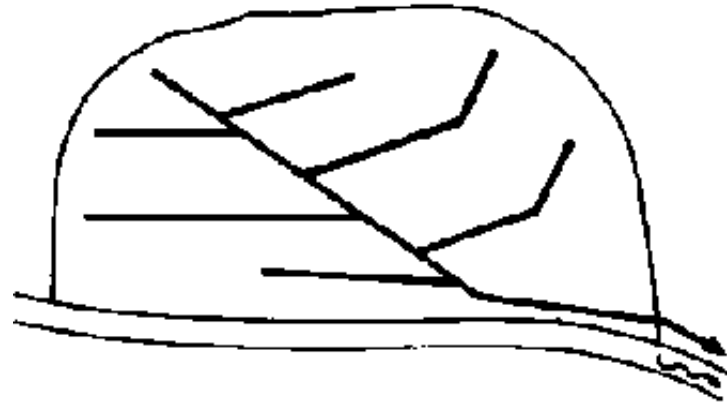
### Fig.6. Patterns of sewerage systems



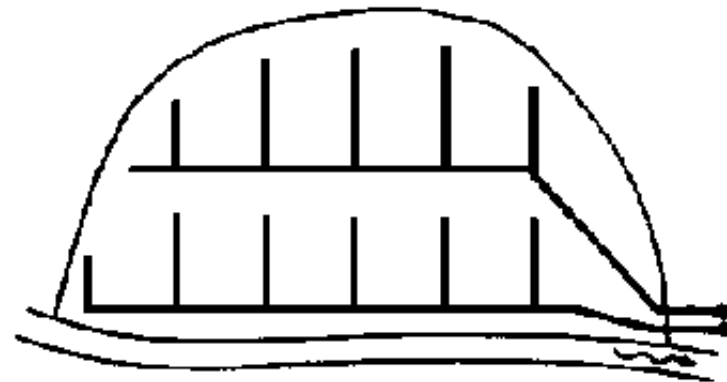
**Perpendicular pattern for storm sewer combined system**



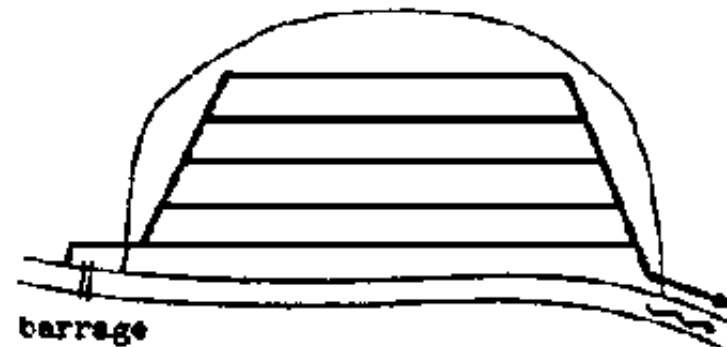
**Perpendicular pattern with interceptor for combined system**



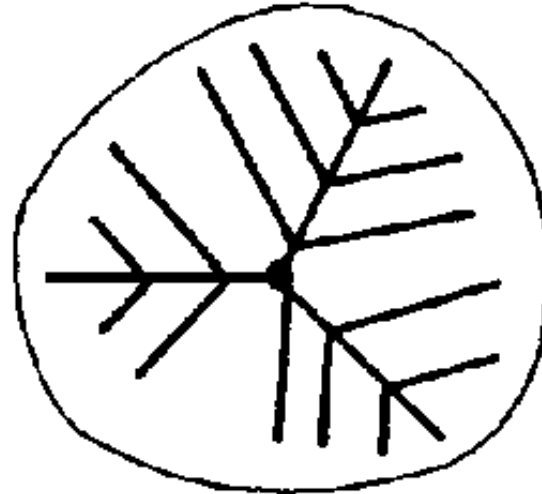
**Pattern with transversal main for sanitary system**



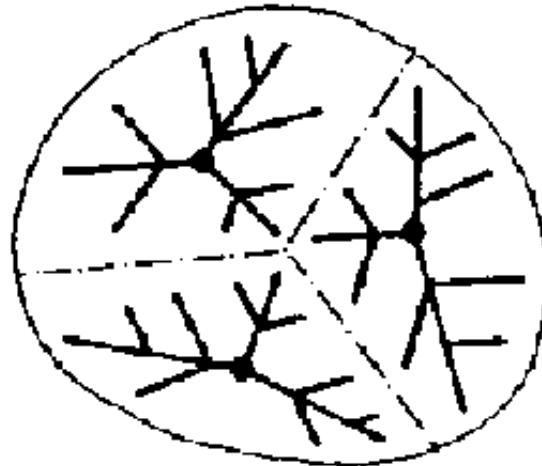
**Pattern for different levels for combined system**



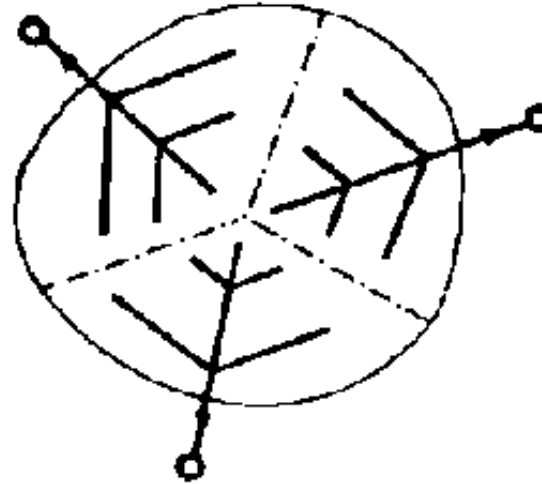
**Parallel pattern for combined system, possible to flush the system with river water**



**Fan pattern for sanitary system**



**Multiple fan pattern (sanitary)**



**Radial system (sanitary or combined)**

## **8.4 Responsibility for Operation and maintenance**

**RESPONSIBILITY FOR OPERATION and maintenance is usually divided between the household and one or more institutions. The most important point is that all concerned should know unambiguously their responsibilities and duties as early in the project as possible. It is better for responsibilities to be spelled out in formal documents, signed by all interested parties, than to rely on the spoken work.**

### **Property owners**

**Under normal circumstances, the householder is responsible for the operation and maintenance of all infrastructure within the plot boundary and possibly up to the junction of the house sewer and collector sewer.**

### **Institutions**

**Institutions are usually responsible for the entire communal network. Where more**



**than one institution is involved (for example where one is responsible for sewage collection and the other for sewage treatment) the most important need is to demarcate clearly areas of responsibility.**

**There is usually very little choice in the selection of which institutions will be involved, but it is necessary to review them to ensure that they have sufficient skills, equipment and funds to carry out their duties correctly. There may be need for institutional strengthening prior to or during the project. Institutional responsibilities need not be carried out by the institution itself; they can be subcontracted to private companies. Such an approach has the advantage of reducing the size of institution and reducing the cost of maintenance. This approach has worked successfully on large schemes such as Orangi in Pakistan, where the demand for routine maintenance is sufficient to support a number of private companies who compete with each other for business. On schemes where the volume of work is small, privatizing maintenance is unlikely to produce significant benefits.**

**There may be circumstances where institutions should be responsible for maintenance of components on private property. An obvious example would be the emptying of interceptor tanks.**

### **Community groups**

**There are a number of examples of communities being responsible for the maintenance of collector sewers, particularly where they run across household plots. Such responsibilities can be household basis where the plot owner is responsible for the length of sewer crossing or adjacent to his/her plot.**

**Alternatively, a group of plot-owners may work together to maintain the collector sewer that they jointly use. It appears that joint responsibility is more appropriate to systems where the collector sewer runs under public land and individual responsibility works better where the sewer crosses the users' plots.**

**Attempts to make communities responsible for trunk sewers have met with little success. Most communities still feel that the removal of waste from large groups of people should remain the responsibility of institutions.**

**The stability of the community has a bearing on the level of responsibility it can support. It is more difficult to enforce responsibility for maintenance in a changing population or where the sewers are installed before properties are occupied. In such areas it is more appropriate to keep consumer responsibility to within the plot boundary.**

### **The private sector**

**The use of the private sector for operation and, particularly, maintenance is often overlooked but has a number of advantages. Competition for work between companies tends to reduce unit costs. The drive for larger profits speeds up work, getting jobs completed faster. The implementing agency may be able to reduce an over-inflated and under-utilized labour force resulting in savings in salaries and management. Contractors are usually less affected by political interference and union demarcations, producing a flexible and swift response of problems.**

**However, the use of contractors has its draw backs as the drive for profits can lead to the use of untrained staff and the taking of short cuts, both of which can**

**produce unsatisfactory standards of work. Contractors can use their wealth to corrupt the selection process. Contributions to politicians' re-election funds and under-paid government officials are not unknown.**

**Operation and maintenance using contractors must therefore be properly managed. Minimum standards of performance must be laid down and monitored. Contractor selection processes must be open to public scrutiny and seen to be fair and reasonable.**

## **8.5 Supervision Operation and maintenance**

**All operation and maintenance activities must be supervised to ensure that they are carried out safely, to an approved standard, at a fair cost and within an acceptable time. Good supervision is based on knowledge of what work must be done, why it is necessary, who is responsible for doing it and what measurable standards must be achieved. This requires the supervisors to be well-educated and trained.**

**Responsibility for supervision usually lies with the implementing agency, which is often a government agency. It is common for day activities to be contracted out to private companies. Whilst this can be much cheaper than using in-house staff, it is important that the responsible agency retains overall management control. It should set and monitor standards and take responsibility for introducing new working practices when required.**

**Supervision of sewerage that has been implemented, community groups often disband and leave day-to-day maintenance to individual residents. This may be**

**satisfactory for minor problems such as local blockages, but dealing with major problems is difficult. Problems affecting a large number of properties require residents to regroup, collect funds and implement repairs. This all takes time and can create considerable social tensions. Localized maintenance by residents with no overall supervision can produce variable standards of workmanship. Residents with minimal funds available for emergencies will spend as little as possible on sewerage repair. This can lead to the long-term deterioration of the network.**

**In general, supervision by staff with local knowledge is an advantage. It allows for continuous contact between supervisors, the network and its users. Any problems that occur can be dealt with quickly and without the need for extensive bureaucracy. However, supervision of on-plot construction is one area where the use of local staff can be disadvantage. Personal knowledge of the families constructing the sewers, and community pressure, may cause the supervisor to accept a standard of construction lower than that, which would normally be acceptable.**

**Inadequate operation and maintenance is the commonest reason for sewerage schemes to fail, and persistent attention is needed to achieve long-term success. Whoever is responsible for carrying out the operation and maintenance of a scheme must be managed by an organization with the skills and legal duty to ensure that it is carried out effectively.**

## **ACHIEVING SUSTAINABLE MAINTENANCE**



***Photograph 9: Cast iron squatting plate with integral drop pipe, fitted in a toilet block with interceptor tank below. The squatting plate is removed to empty the tank***



***Photograph 10: A well-stocked plumbing and drainage store in Pakistan, promoting private sector maintenance of the sewer network.***



**Photograph 11: A low-income housing area in Pakistan with a community constructed collection sewer. The concrete access point covers are poorly fitted, allowing silt and garbage to enter the sewer to cause maintenance problems.**



**Photograph 12: Specially shaped concrete blocks have been manufactured in Brazil**

***to allow the construction of small diameter access chambers.***

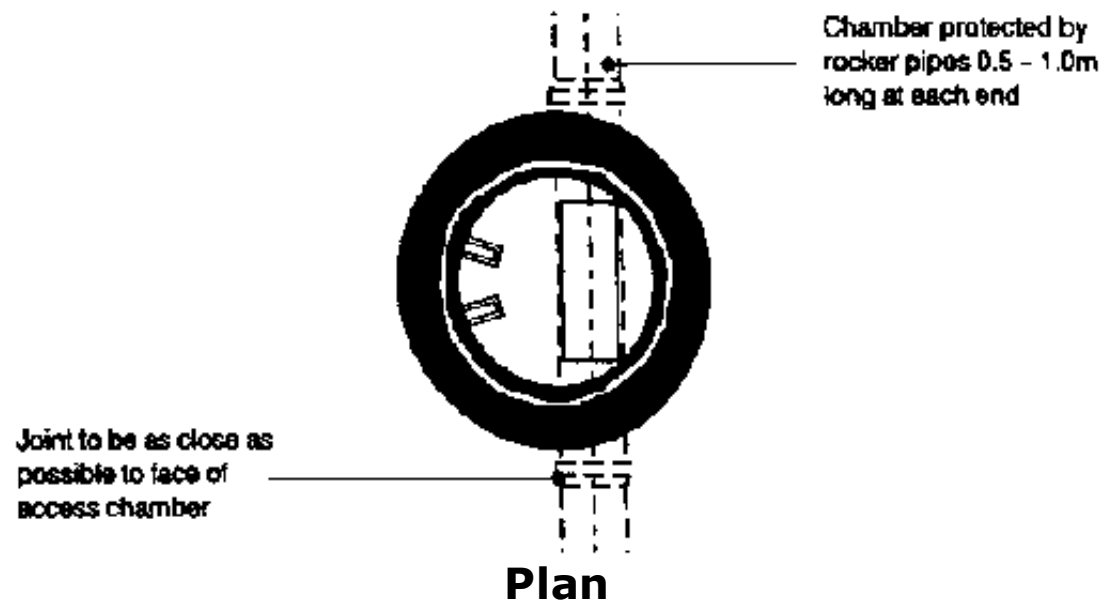
## 8.6 Glossary of terms

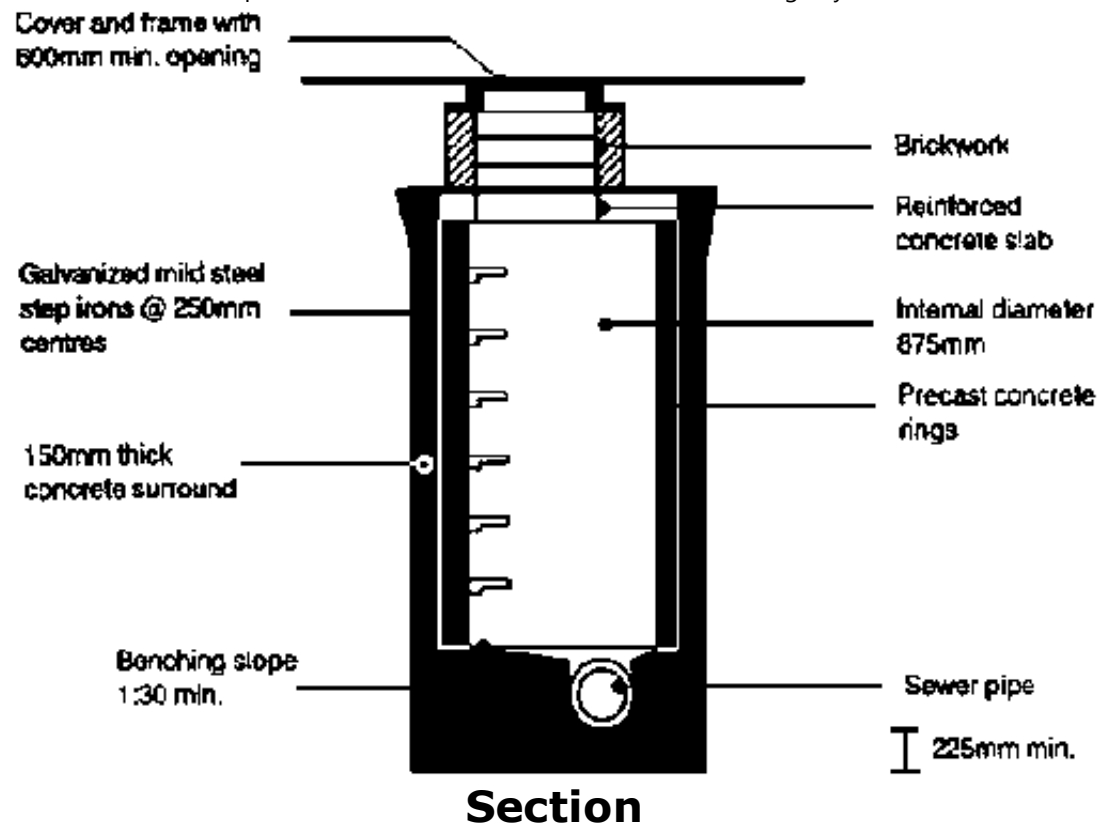
### Access points

**Points of entry into the sewer network for observation and maintenance. They are usually large enough to allow the entry of a person or persons (figure A 1.1). They are located at sewer intersections, changes in sewer direction, gradient or size and at spacing dictated by the methods of sewer cleaning being used.**

### SUSTAINABLE SEWERAGE

**Figure A 1.1 *Detail of a typical access chamber for a sewer 1.35 - 3.0m deep***  
**Source: *Adapted from WAA (1989)***





## Access point on the highway boundary

The same as any other property access point located on the property and adjacent to the highway boundary. It is used for observation and maintenance of the sewer and also marks the change of responsibility. Upstream it is the responsibility of the property-owner whilst downstream it is the responsibility of the authority in charge of maintenance of the communal sewerage network.

## Branch drains

**Pipes connected to the waste outlet to water-using appliances such as WCs and**



**wash-basins after the water-trap. As such they usually run above ground.**

## **Collector sewer**

**Collects effluent from properties and other waste-producing sources (such as industries) and carries them by gravity and in increasing volume to the discharge point. They are commonly constructed under public highways so as to be accessible to properties on both sides of the road and easy to reach for maintenance.**

## **Grease trap**

**A small underground tank attached to a house sewer. It is designed to collect excess grease and/or sand and prevents them precipitating in the nearby sewer network and causing blockages. (Sand is used for washing pots pans.)**

## **Gully trap**

**Gully traps are installed where branch drains enter house sewers. They allow the entry of sullage into the house sewers whilst preventing the escape of foul sewer gases.**

## **House sewer (for house drain)**

**Collect wastes discharged from individual or groups of sanitary fittings via the branch drains inside a building. The house sewer is nearly always below ground.**

## **Interceptor tanks**

**Underground storage tanks set in the line of the house sewer, usually near the highway boundary, designed to reduce the amount of solids in the sewer network. Small tanks have a liquid volume of around 250 litres and provide 4 to 6 hours' retention, while large tanks provide approximately 24 hours' storage.**

### **Property access point**

**A hole over the house sewer which gives access for observation and maintenance. Access points are commonly provided wherever the house sewer changes directions, slope or size and at sewer intersections.**

### **Trunk sewer**

**A sewer receiving effluent from a number of collector sewers and carrying sewage in bulk from one point to another. It usually receives very little effluent directly from individual properties.**

### **Ventilation pipe**

**A vertical pipe extending from the house sewer to a point above the highest opening in the property. The pipe is open at the top and allows the escape of the foul gases produced in the sewer system to be discharged into the atmosphere without causing annoyance to residents.**

**The ventilation pipe also conveys wastes from upper floors to the house sewer.**

### **Sewage**

## **Liquid waste of community - waste water.**

### **Sewer**

**A pipe or conduit that carries waste water or rainwater.**

### **Sewerage**

**Process of removing sewage.**

### **Sewerage system**

**The entire waste water collection system (pipes appurtenances, pumping stations, etc.**

### **Domestic sewage**

**Sanitary sewage, or house sewage or foul waste water.**

### **Industrial waste water**

### **Trade waste water**

### **Storm run-off**

**Storm water, rainwater or drainage water.**

### **Sanitary sewer**

## **Sewer for domestic sewage.**

### **Storm Sewer**

### **Rainwater sewer or sewer for storm water**

### **Combined sewer**

### **Sewer for domestic sewage and rainwater**


**D.W.F.** = Dry Weather Flow-Flow in combined sewer during dry weather periods. (no rain) - domestic industrial waste water + infiltration water (leak).

**R.W.F.** = Rain Water Flow - Flow in storm sewer during rainstorms

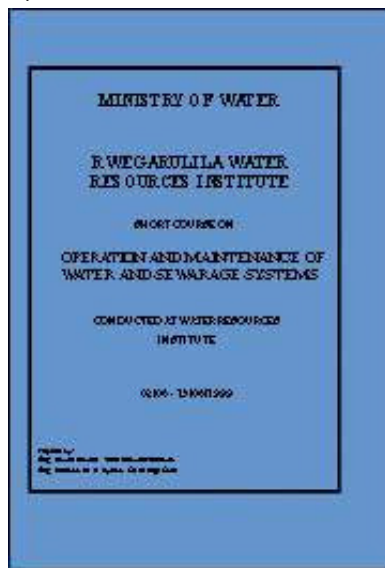
**Combined D.W.F. + R. W. F.  
flow =**



[Home](#) > [ar](#).[cn](#).[de](#).[en](#).[es](#).[fr](#).[id](#).[it](#).[ph](#).[po](#).[ru](#).[sw](#)

 **Operation and Maintenance of Water and Sewerage Systems  
(Ministry of Water - Tanzania - Rwegarulila Water  
Resources Institute, 1999, 90 p.)**

  **D. Operation and Maintenance Tasks and Their  
Frequencies**



# 1. Water Supply

## 2. Sanitation

### Operation and Maintenance of Water and Sewerage Systems (Ministry of Water - Tanzania - Rwegarulila Water Resources Institute, 1999, 90 p.)

#### D. Operation and Maintenance Tasks and Their Frequencies

##### 1. Water Supply

##### 1.1 Operational Tasks

Work Item	Operational to be carried out			
	Day	Month	3 Months	6 Months
Diversion drains				Clean out gravel before on set of rains.
Overflow	Measure and	Inspect.	Clean and	

chamber	record flow.		disinfect with 50ppm chlorine solution.	
Fencing		Inspect.		
Storage reservoir		Cut grass around check water level indicator.	Check operation of all valves inspect ventilator if insect proof.	Check fence drain and clean with disinfectant of 50ppm chlorine solution. (paint metal work every three years)
Water mains	Investigate and report on leakage. Repair and check public supply points.	Inspect routes & flush dead ends.	Check air valves and wash out valves.	Carry out waste checks as necessary.
Pump house	Clean p/h floor and remove grease oil deposits.	Clean bush around p/h. Clean drain.		
Pump/Engine/motor	Wipe and clean dirt record time of running, fuel consumption or power consumption.	Replace oil filter check couplings, water seals and foundation bolts.	Replace lubricating oil, check bolts, nuts, check foot valve.	Make overhaul engine and pump as specified number of hours by the manufacturer.
Intake	clean			

screens

## 1.2 Maintenance tasks and responsibilities

Item description	Maintenance task	Frequency
Spring collecting chamber	<ul style="list-style-type: none"> <li>- record flow to supply</li> <li>- inspect collecting chamber</li> <li>- inspect fencing</li> <li>- clean adjacent area</li> <li>- clean and disinfect collection chamber</li> <li>- surface water drains</li> <li>- outflow</li> </ul>	Daily Monthly Monthly Three Months Three Months
Water mains	<ul style="list-style-type: none"> <li>- repair and replace defective taps</li> <li>- repair and replaces defective pipes</li> </ul>	When needed When needed
Area around the public taps	<ul style="list-style-type: none"> <li>- to clean the surrounding area</li> <li>- to help with the mason to repair floor</li> </ul>	Weekly When needed
Pump house	<ul style="list-style-type: none"> <li>- clean and sweep floors, walls, pies, windows, etc.</li> <li>- clean drains</li> <li>- paint wall door and windows</li> </ul>	Daily Monthly Yearly
Pump/Engine/Motor	<ul style="list-style-type: none"> <li>- clean oil and dirt</li> <li>- record running time and fuel consumption</li> <li>- replace oil/diesel</li> <li>- overhaul engine and pump</li> </ul>	Daily Daily Monthly Specified by manufacturer

River intake	<ul style="list-style-type: none"> <li>- clean screens</li> <li>- record river level</li> <li>- record quantity abstracted</li> <li>- clean adjacent area drain intake chamber and</li> <li>- chlorinate</li> </ul>	<ul style="list-style-type: none"> <li>Daily</li> <li>Daily</li> <li>Daily</li> <li>1 month</li> <li>3 months</li> </ul>
--------------	---	--

## 2. Sanitation

### a. VIP Latrine

#### Cleaning

- **Individual Household: Regular cleaning is undertaken by the owner.**
- **Communal/:Regular cleaning is shared by all the people who use the public latrine, working on rotation basis; or Regular cleaning is undertaken by the people paid to do it.**

#### Maintenance

- **Regular emptying of the latrine**
- **Regular inspection and repair or replacement of fly screen, vent pipe, floors, walls, door and roof, if necessary.**

### b. Septic Tank



## **Cleaning**

- **Periodic cleaning of toilet facility**
- **Periodic disinfection of toilet by hand-spraying with "Lysol".**

## **Maintenance and Repairs**

- **Emptying of the pit by vacuum truck.**
- **Replacement of broken squatting pan**
- **Repair and maintenance of toilet tank and superstructure.**

### **c. Septic tank**

#### **Cleaning**

- **Flushing after use.**
- **Regular cleaning of toilet facility.**

#### **Maintenance and repairs**

- **Emptying the sludge tank by vacuum truck**
- **Regular checking of drainage pipe for effluent disposal**

### **d. Sewerage**

#### **Cleaning**

- **Regular cleaning of sewer line and appurtenances is undertaken by the sewerage authority.**
- **Regular cleaning is done at manholes, rain inlets, grease traps and spillways.**

## **Maintenance and Repairs**

- **Cleaning of clogged sewer line**
- **Repair/replacement of broken sewer, manholes and other appurtenances.**
- **Maintenance of wastewater treatment plant if sewage water is treated prior to disposal.**

## **e. Waste Stabilization Pond**

### **Operation**

- **It is generally desirable to fill it to a small depth with dilute sewage and allow a spontaneous growth of algae to establish itself in the pond within a short time.**
- **Operate and pond with full flow**
- **Periodic visit by an operator for satisfactory operation.**
- **Periodic reading of flow in the measuring weir**

### **Maintenance**

- **Regular weed and grass trimming and other usual measures to prevent mosquito breeding**
- **Regular removal of floating scums and mats**
- **Desluddging once every few years.**

### OPERATION AND MAINTENANCE TASKS

NO.	WORK ITEM	OPERATIONAL TASKS TO BE CARRIED OUT				ANNUAL
		DAILY	MONTHLY	3 MONTHS	6 MONTHS	
1	INTAKE STRUCTURE	<ul style="list-style-type: none"> <li>- clean screens</li> <li>- inspect all valves</li> <li>- measure and record flow or level of water source.</li> <li>- Record qty of water extracted.</li> </ul>	<ul style="list-style-type: none"> <li>- Inspect and remove deposits at intake chamber</li> <li>- Clean for valves</li> <li>- Clear bush around intake</li> </ul>	<ul style="list-style-type: none"> <li>- clean intake chamber and disinfect with 50ppm c/2 soln.</li> </ul>		
2	PUMPING STATION	<ul style="list-style-type: none"> <li>- inspect all valves</li> <li>- priming process</li> </ul>	<ul style="list-style-type: none"> <li>- Inspect packing</li> <li>- Inspect performance</li> </ul>	<ul style="list-style-type: none"> <li>- inspect roof flow and walls</li> <li>- replace lubricating oil,</li> </ul>		<ul style="list-style-type: none"> <li>- overhaul engine + pump as per specified</li> </ul>

		<ul style="list-style-type: none"> <li>- clean pump house</li> <li>- remove dirty from pumping units</li> <li>- record flow of water in pipe main</li> <li>- record power or fuel used</li> <li>- record pressure gauges.</li> </ul>	<ul style="list-style-type: none"> <li>of valves meters and tanks</li> <li>- Lubrication of machine parts</li> <li>- Tighten foundation bolts</li> <li>- Replace oil filters and waterseals.</li> </ul>	<ul style="list-style-type: none"> <li>and filters as per manufacture instructions.</li> </ul>		<ul style="list-style-type: none"> <li>numbers of running hours by manufacturer.</li> </ul>
3	TREATMENT PLANT	<ul style="list-style-type: none"> <li>- record and maintain flows in the treatment units.</li> <li>- Remove of sludge in sedimentation tank if mechanical devices used.</li> <li>- Dosing</li> </ul>	<ul style="list-style-type: none"> <li>- removal of sludge if manual</li> <li>- back washing of R.S.F.</li> <li>- inspect valves and wall</li> </ul>	<ul style="list-style-type: none"> <li>- scraping of top 3cm thick, clean the sand dry and store in slow sand filters.</li> </ul>	<ul style="list-style-type: none"> <li>- clean gravel in roughing filters.</li> <li>- apply plain or white wash walls of chambers.</li> </ul>	

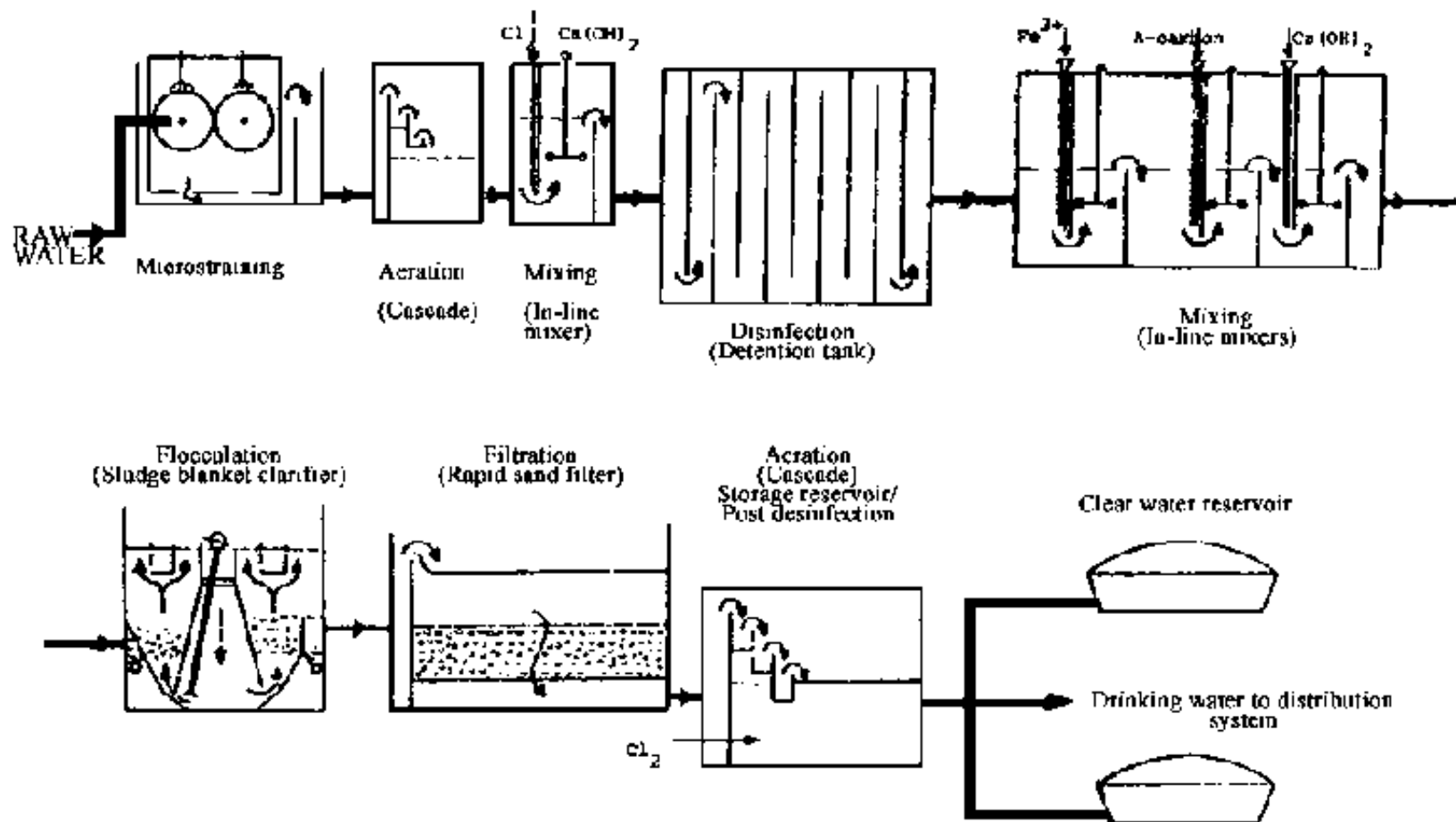
		<p>respective chemicals required for treatment</p> <ul style="list-style-type: none"> <li>- Record inflows and outflows</li> <li>- General cleanliness</li> <li>- Check position of all valves</li> <li>- Check leakages.</li> </ul>				
4	WATER MAINS	<ul style="list-style-type: none"> <li>- inspect routes of mains</li> <li>- inspect leakages</li> <li>- inspect washouts and air valves.</li> </ul>	<ul style="list-style-type: none"> <li>- Inspect air valves washouts</li> <li>- Inspect sluice valves.</li> </ul>			
5	STORAGE TANKS	<ul style="list-style-type: none"> <li>- check the operating valves</li> </ul>	<ul style="list-style-type: none"> <li>- clear bush around tank</li> <li>- cleaning of inside of tank</li> <li>- flust sludge</li> </ul>	<ul style="list-style-type: none"> <li>- inspect cracks in walls and chambers.</li> </ul>		<ul style="list-style-type: none"> <li>- white wash or any colour application to tank walls.</li> </ul>

			through washout valve.			
6	DISTRIBUTION NETWORK	<ul style="list-style-type: none"> <li>- Investigate and report on leakages</li> <li>- Sampling for water quality analysis</li> <li>- Attend customer problems</li> <li>- Inspect misuse of water by the customers</li> <li>- New connections</li> </ul>	<ul style="list-style-type: none"> <li>- inspect routes and flush dead end and wash outs.</li> <li>- Inspect hydrants</li> </ul>	<ul style="list-style-type: none"> <li>- check air valves,</li> <li>- inspect washouts and chambers.</li> <li>- Inspect illegal connections</li> <li>- Check both domestic and public stand pipes.</li> <li>- Re-connection of disconnected customers.</li> </ul>		
7	SEWARAGE SYSTEM	<ul style="list-style-type: none"> <li>- check overflows and spillage of sewage in streets.</li> </ul>	<ul style="list-style-type: none"> <li>- cleaning of sewer line and appurtenances</li> </ul>	<ul style="list-style-type: none"> <li>- cleaning of manholes, rain inlets, grease traps and spillways.</li> </ul>	<ul style="list-style-type: none"> <li>- remove sediments with high pressure pipes.</li> </ul>	

<b>No.</b>	<b>ITEM DESCRIPTION</b>	<b>MAINTENANCE TASKS</b>	<b>FREQUENCY</b>
1	INTAKE STRUCTURE	<ul style="list-style-type: none"> <li>- Repair or replacement of screens and strainers</li> <li>- Remove of depositions in intake chamber and disinfect</li> <li>- Repair of crack in wing walls and floor of intake</li> </ul>	Water needed Weekly or twice per month depending on season. - when occurs
2	PUMPING STATION	<ul style="list-style-type: none"> <li>- cleans and sweep floors and walls</li> <li>- clean drains and disinfect</li> <li>- clean dirt, oil in pumping units</li> <li>- repair pump and engine</li> <li>- overhaul engine and pumps</li> </ul>	<ul style="list-style-type: none"> <li>- Daily</li> <li>- Monthly</li> <li>- Daily</li> <li>- When required</li> <li>- As specified by manufacturer</li> </ul>
3	TREATMENT PLANT	<ul style="list-style-type: none"> <li>- repair of the operating valves</li> <li>- removal and disposal of sludge from sedimentation tanks</li> <li>- replacement of filter media to designed depth inspection and repair</li> <li>- the underdrainage system of filter units</li> <li>- inspection and repair of cracks in walls of filter units, raw water and clear water reservoirs</li> </ul>	<ul style="list-style-type: none"> <li>- when needed</li> <li>- Daily/weekly</li> <li>- when needed</li> <li>- annually</li> <li>- monthly</li> </ul>
4	WATER MAINS	<ul style="list-style-type: none"> <li>- inspect and repair leakages</li> <li>- inspect and repair valves e.g. air valves</li> </ul>	<ul style="list-style-type: none"> <li>- when occurs</li> <li>- every 3 months</li> </ul>


		washout gate valves - repair of valve chambers and covers	- every 6 months - seasonal
5	STORAGE TANKS	- <del>cut bush and trees in the line</del> - Remove of sludge in tank floor & chambers - Repair valves - Paint tank wall and ladders	- weekly - as needed - annual
6	DISTRIBUTION NETWORK	- Inspection and repair of pipe bursts - Inspection and repair leakages - To repair valves and other fittings	- As occurs - As occurs - As needed.

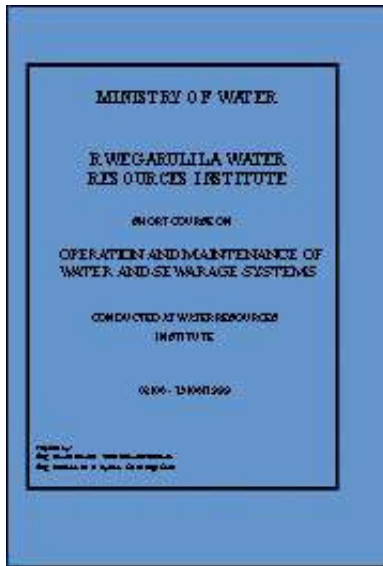




**Water treatment plant "Berenplaat" (Rotterdam)**

[Home](#) > [ar](#).[cn](#).[de](#).[en](#).[es](#).[fr](#).[id](#).[it](#).[ph](#).[po](#).[ru](#).[sw](#)

 **Operation and Maintenance of Water and Sewerage Systems  
(Ministry of Water - Tanzania - Rwegarulila Water  
Resources Institute, 1999, 90 p.)**



- **ANNEXES**
- 1. Class Test (in Swahili)
  - 2. Evaluation Form (in Swahili)
  - 3. Group work - Operation and Maintenance of the following:
    - Intake structure
    - Pumping station
    - Water treatment unit
    - Water mains
    - Water tanks
    - Sewerage systems

**Operation and Maintenance of Water and Sewerage Systems (Ministry of Water - Tanzania - Rwegarulila Water Resources Institute, 1999, 90 p.)**

## **ANNEXES**

### **1. Class Test (in Swahili)**

**KOZI FUPI YA O&M YA MAMLAKA ZA MAJI SAFI NA MAJI TAKA**

**MTIHANI (13/08/1999)**

### **Maelekezo**

**Chagua jibu sahihi na andika herufi yake kwenye karatasi iliyo ambatanishwa. Andika namba yako utakayopewa, kwenye karatasi hiyo.**

1. Ukifungua tapu ya maji iliyo kavu utasikia sauti ya shiiiiiii. Ukigusa kwenye mdomo wa tapu hiyo kutakuwa na msukumo:
  - (a) Unaovuta kwa ndani
  - (b) Unaosukuma kwa nje
  - (c) Unaosukuma ndani na nje
  - (d) Hakuna msukumo wowote.
  
2. Ni kitu gani muhimu kinachozingatiwa katika uteuzi wa Chanzo cha Maji.
  - (a) Ubora wa maji
  - (b) Wingi wa maji
  - (c) Utegemezi wa Chanzo
  - (d) Mwinuko wa maji kwa kulinganisha na eneo linalohitaji maji
  
3. Viwango vya ubora wa maji katika nchi zinazoendelea uko chini, nini kwa sababu:
  - (a) kutojua umuhimu wa maji safi
  - (b) kutokuwa na fedha za kigeni
  - (c) Kutokuwa na watalamu wa kutosha
  - (d) kutokuwa na fedha za kutosha.
  
4. Kazi ambayo huwa na matatizo makubwa katika miradi ya maji ni:
  - (a) upangaji
  - (b) Usanifu
  - (c) Ujenzi
  - (d) O&M.

5. Ukarabati wa miradi ya maji, unalenga katika vitu vitatu muhimu:-

- (a) Usalama wa majengo, uendeshaji, na afya za walaji.
- (b) Uimara na usalama wa majengo, uendesjaji bora, na usafi wa maji.
- (c) Usalama wa majengo, uendeshaji bora na ongezeko la mapato.
- (d) Usalama wa majengo ya maji, uendeshaji bora wa afya z za wateja.

6. Ukaguzi muhimu wa miradi ya maji ni wakati mradi

- (a) Haujaanza kuzalisha maji
- (b) Wakati mradi unazalisha maji
- (c) Baada ya muda mrefu wa kuzalisha
- (d) Unapokuwa umesimamishwa.

7. Umuhimu wa kumbukumbu ni:-

- (a) Kutoa taarifa za vipuri vitakavyo hitajika wakati wa matengenezo.
- (b) Kutoa taarifa ambazo zinaweza kusaidia katika mipango ya baadae.
- (c) Kutoa taarifa za mapato na matumizi
- (d) kusaidia katika kupanga ratiba ya ukarabati.

8. Makusanyo yanayopatikana kutokuwa na kuuza maji, yanatakiwa

- (a) Kulipa mishahara ya wafanyakazi
- (b) Kulipia malipo yote ya O&M.
- (c) Kununulia mafuta na vipuri vyote vya mitambo
- (d) Kuweka benki

9. Mara nyingi wana siasa wetu huwa wanapendelea

- (a) Kukamilisha miradi iliyokwisha anzishwa
- (b) Kufuatilia O&M.
- (c) Kubuni mikakati ya kufanikisha O&M
- (d) Kuanzisha miradi mipya

10. Maana ya neno "Sewerage" ni:-

- (a) Taratibu za kuondoa maji mchafu
- (b) Bomba la kubebea maji machafu
- (c) Maji machafu kutoka kwenye makazi ya watu
- (d) Maji machafu kutoka kwenye makazi ya watu pamoja na maji ya mvua.

## **2. Evaluation Form (in Swahili)**

### **FOMU YA TATHMINI YA KOZI YA O&M**

**Fomu hii imeandaliwa ili kupata maoni ya washiriki kwa kozi. Tathmini inaanza na namba 5, ambayo ndiyo kubwa kuliko zote, na kutelemka mpaka 1 ambayo ndiyo ndogo kuliko zote.**

- 5 - Nzuri sana**
- 4 - Nzuri**
- 3 - Inaridhisha**
- 2 - Hafifu**
- 1 - Hafifu Sana**

**Andika namba inayo stahili, ndani ya sanduku, kila baaada ya maelezo yaliyotajwa hapo chini.**

## 1. SOMO

- Ubora wa Somo
- Kiasi ulichifaidika
- Mafanikio ya mategemeo
- Majadiliano darasani
- Matembezi ya ruvu Juu
- Muda wa wiki 2 wa somo
- Tathmini ya wastani wa Somo
- Picha na maelezo ya "video"

## 2. MWALIMU

- Uwezo wa kujieleza
- Upeo wake katika somo
- Uzoefu
- Mtiririko wa maelezo
- Kueleweka
- Uchangamfu

### **3. Group work - Operation and Maintenance of the following:**

#### **- Intake structure**

#### **GROUP WORK 1 (03/08/1999)**

**Explain how operation and maintenance is being carried out at your work places for the intake structures. Express your answer as follows:**

**(a) Operational Tasks and at what frequencies they being done.**

**(b) Maintenance Tasks and at what frequencies they are being conducted.**

#### **- Pumping station**

#### **GROUP WORK 04/08/1999**

**Express your answer as follows:**

- (a) Operational Tasks and at what frequencies they are being done**
- (b) Maintenance Tasks and at what frequencies they are being conducted**

**- Water treatment unit**

**GROUP WORK 05/08/1999**

**Express your answer as follows**

- (a) Operational Tasks and at what frequencies they are being done.**
- (b) Maintenance Tasks and at what frequencies they are being conducted**

**- Water mains**

**GROUP WORK 06/08/1999**

**Express your answer as follows:**

- (a) Operational Tasks and at what frequencies they are being done.**
- (b) Maintenance tasks and at what frequencies they are being conducted**

**- Water tanks**

**GROUP WORK 09/08/1999**

**Express your answer as follows:**

- (a) Operational Tasks and at what frequencies they are being done.**
- (b) Maintenance tasks and at what frequencies they are being conducted**



## **- Sewerage systems**

### **GROUP WORK 12/08/1999**

**Express your answer as follows:**

- (a) Operational Tasks and at what frequencies they are being done.**
- (b) Maintenance tasks and at what frequencies they are being conducted**

