

such spillage from community wells is used to water vegetable gardens or community nurseries.

If the well platform is too big and smooth, there is a great temptation on the part of the villagers to do their laundry and other washing around the well.

This should be discouraged. In villages where animals run loose it is necessary to build a small fence around the well to keep out animals, especially poultry and pigs, which are very eager to get water, but tend to mess up the surroundings.

Sources:

Koegel, Richard G. Report. Ban Me Thuot, Vietnam: International Voluntary Services, 1959. (Mimeographed.)

Mott, Wendell. Explanatory Notes on Tubewells. Philadelphia: American Friends Service Committee, 1956. (Mimeographed.)

Hand-Operated Drilling Equipment

Two methods of drilling a shallow tubewell with hand-operated equipment are described here: Method A, which was used by an American Friends Service Committee (AFSC) team in India, operates by turning an earth-boring auger. Method B, developed by an International Voluntary Services (IVS) team in Vietnam, uses a ramming action.

Earth Boring Auger

This simple hand-drilling rig can be used to dig wells 15 to 20cm (6" to 8") in diameter up to 15 meters (50') deep.

Tools and Materials

Earth auger, with coupling to attach to 2.5cm (1") drill line (see entry on tubewell earth augers)

Standard weight galvanized steel pipe:

For Drill Line:

4 pieces: 2.5cm (1") in diameter and 3 meters (10') long (2 pieces have threads on one end only; others need no threads.)

2 pieces: 2.5cm (1") in diameter and 107cm (3 1/2") long

For Turning Handle:

2 pieces: 2.5cm (1") in diameter and 61cm (2') long

2.5cm (1") T coupling

For Joint A:

4 pieces: 32mm (1 1/4") in diameter and 30cm (1') long

Sections and Couplings for Joint B:

23cm (9") Section of 32mm (1 1/4") diameter (threaded at one end only)

35.5cm (14") Section of 38mm (1 1/2") diameter (threaded at one end only)

Reducer coupling: 32mm to 25mm (1 1/4" to 1")

Reducer coupling: 38mm to 25mm (1 1/2" to 1")

8 10mm (3/8") diameter hexagonal head machine steel bolts 45mm (1 3/4") long, with nuts

2 10mm (3/8") diameter hexagonal head machine steel bolts 5cm (2") long, with nuts

9 10mm (3/8") steel hexagonal nuts

For Toggle Bolt:

1 3mm (1/8") diameter countersink head iron rivet, 12.5mm (1/2") long

1 1.5mm (1/16") sheet steel, 10mm (3/8") x 25mm (1")

Drills: 3mm (1/8"), 17.5mm (13/16"), 8.75mm (13/32")

Countersink

Thread cutting dies, unless pipe is already threaded

Small Tools: wrenches, hammer, hacksaw, files

For platform: wood, nails, rope, ladder

Basically the method consists of rotating an ordinary earth auger. As the auger penetrates the earth, it fills with soil. When full it is pulled out of the hole and

emptied. As the hole gets deeper, more sections of drilling line are added to extend the shaft. Joint A (Figures 1 and 2) is a simple method for attaching new

fig1x200.gif (600x600)

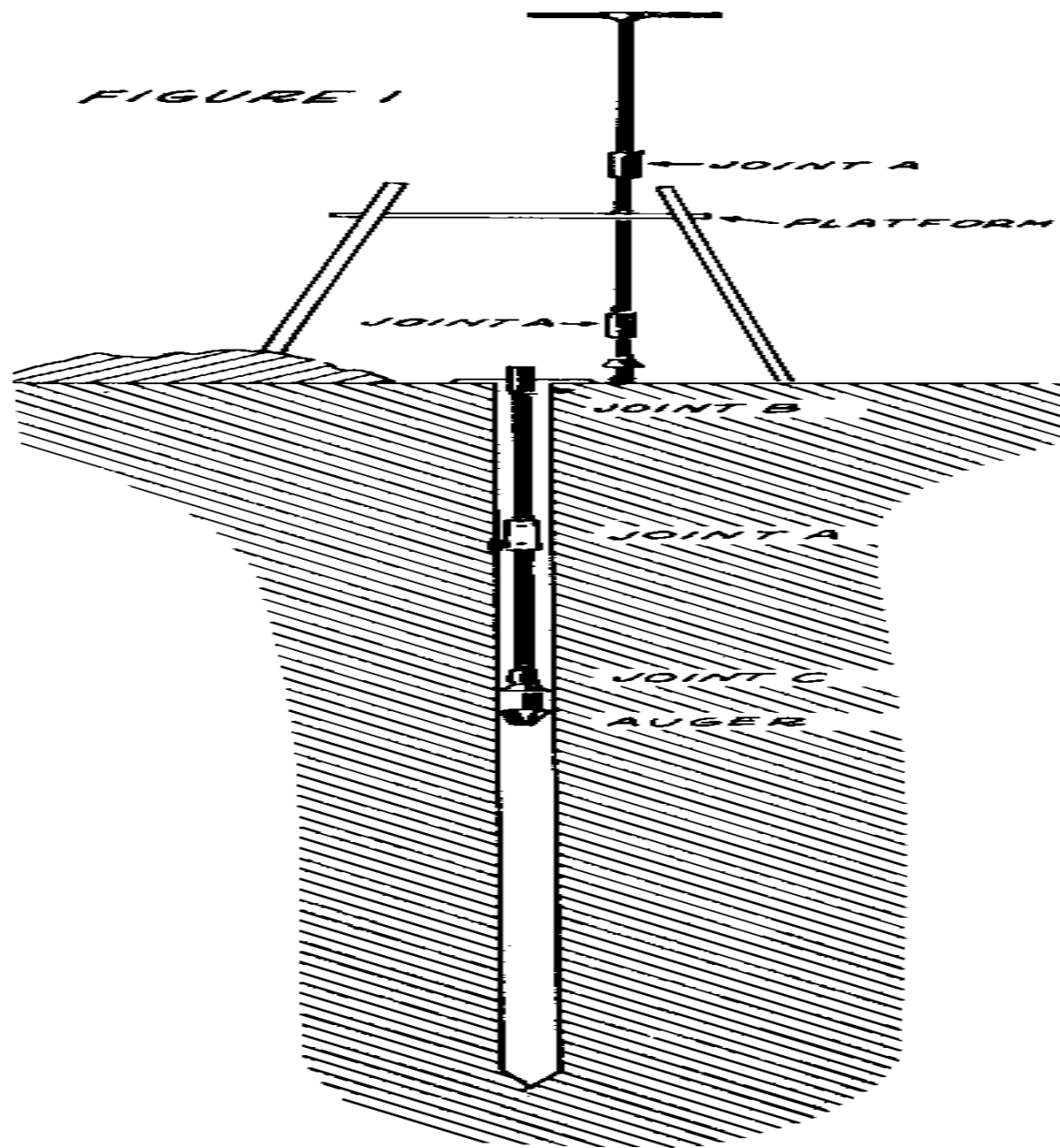

sections.

By building an elevated platform 3 to 3.7 meters (10 to 12 feet) from the

ground,

a 7.6-meter (25 foot) long section of drill line can be balanced upright. Longer lengths are too difficult to handle. Therefore, when the hole gets deeper than 7.6

meters (25 feet), the drill line must be taken apart each time the auger is removed for emptying. Joint B makes this operation easier. See Figures 1 and 3.

fig3x200.gif (600x600)

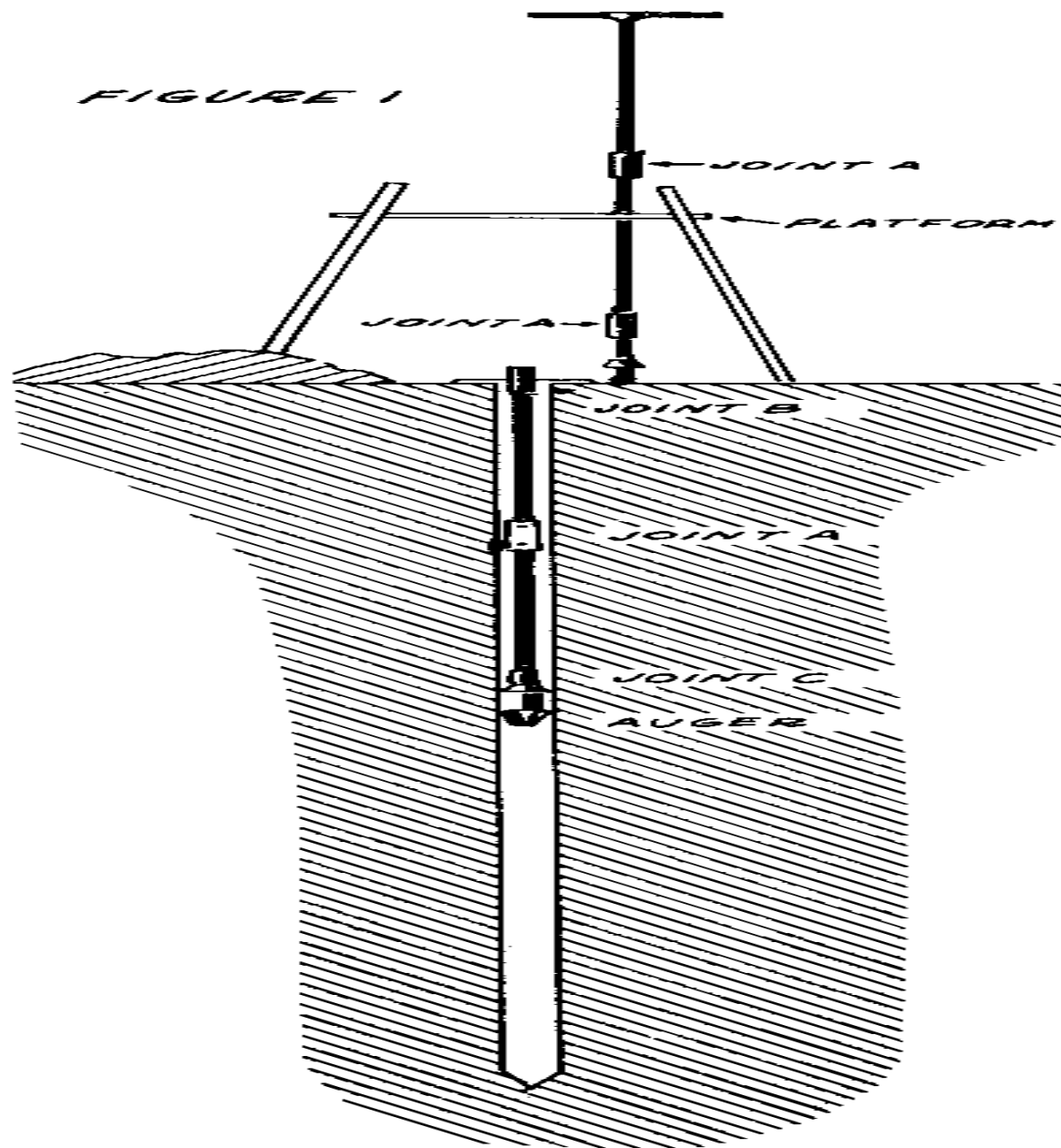

Joint C (see construction details for Tubewell Earth Auger) is proposed to allow rapid emptying of the auger. Some soils respond well to drilling with an auger

that has two sides open. These are very easy to empty, and would not require Joint C. Find out what kinds of augers are successfully used in your area, and do a bit of experimenting to find the one best suited to your soil. See the entries on augers.

Joint A has been found to be faster to use and more durable than pipe threaded connectors. The pipe threads become damaged and dirty and are difficult to start.

Heavy, expensive pipe wrenches get accidentally dropped into the well and are hard to get out. These troubles can be avoided by using a sleeve pipe fastened with two 10mm (3/8") bolts. Neither a small bicycle wrench nor the inexpensive bolts will obstruct drilling if dropped in. Be sure the 32mm (1 1/4") pipe will fit over your 25mm (1") pipe drill line before purchase. See Figure 2.

fig2x20.gif (600x600)

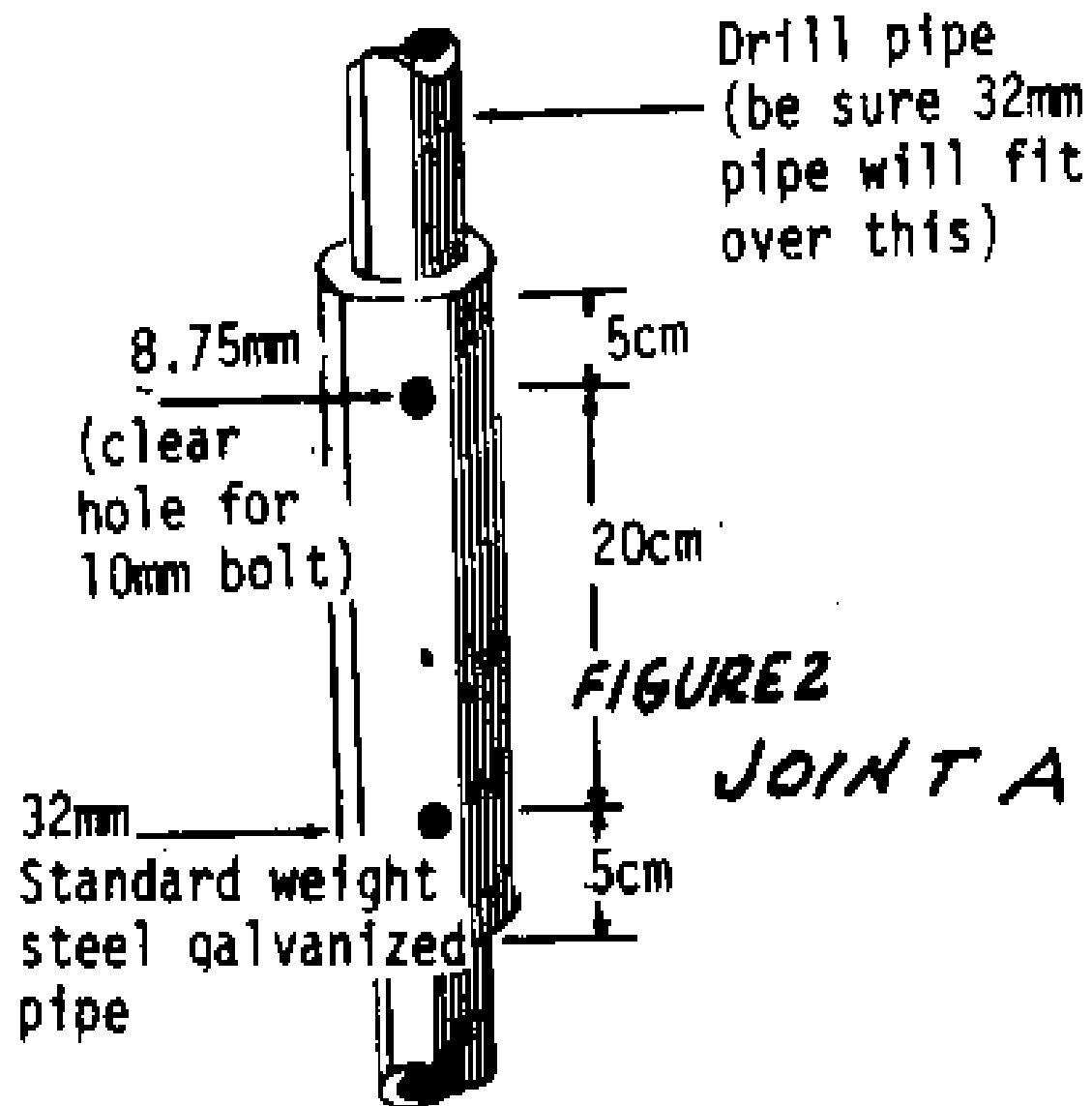

Four 3-meter (10') sections and two 107cm (3 1/2') sections of pipe are the most convenient lengths for drilling a 15-meter (50') well. Drill an 8.75mm (13/32")

diameter hole through each end of all sections of drill line except those attaching to Joint B and the turning handle, which must be threaded joints. The holes should be 5cm (2") from the end.

When the well is deeper than 7.6 meters (25'), several features facilitate the emptying of the auger, as shown in Figures 3 and 4. First, pull up the full auger

fig4x200.gif (600x600)

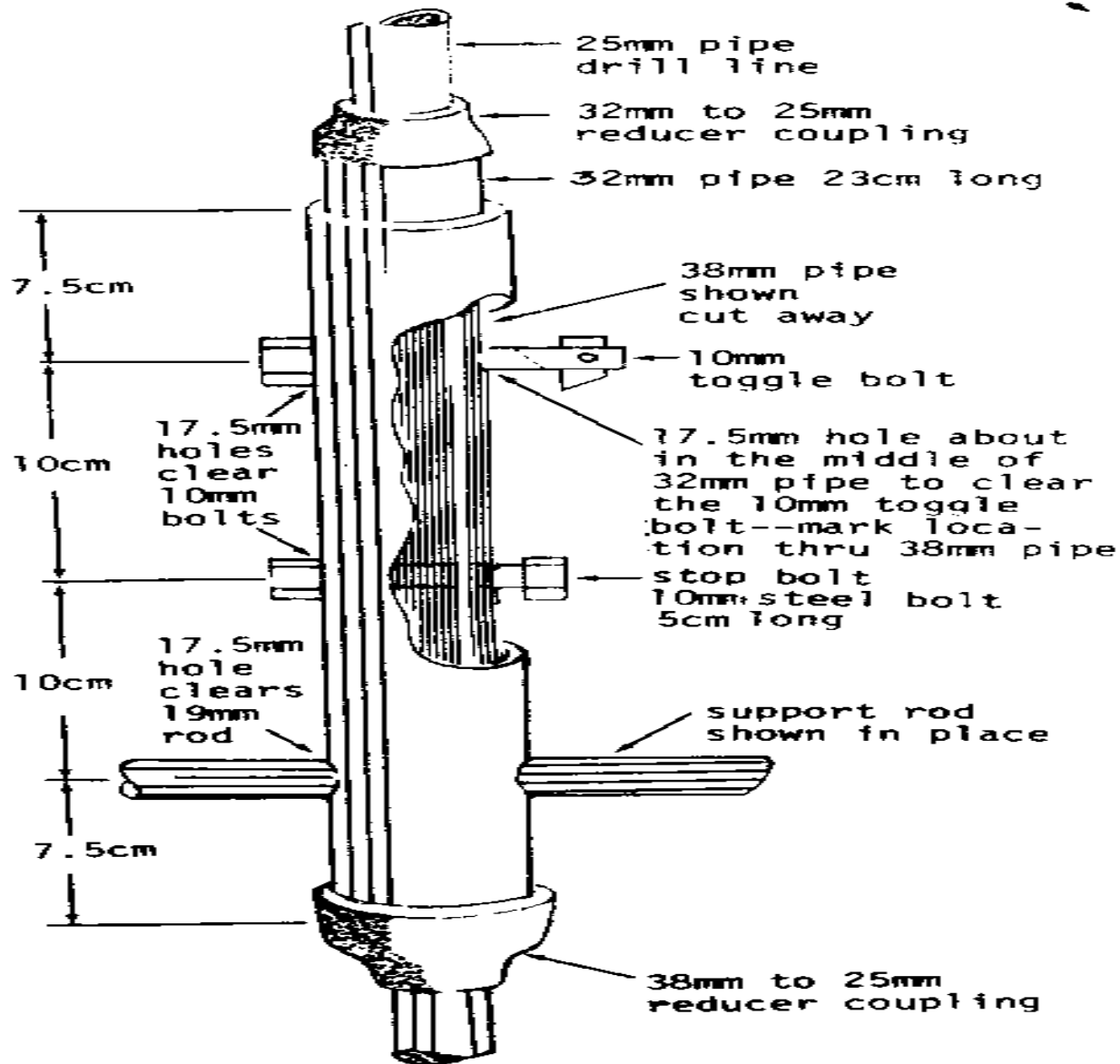

FIG. 3 JOINT B

until Joint B appears at the surface. See Figure 4A. Then put a 19mm (3/4")

fig4x21.gif (600x600)

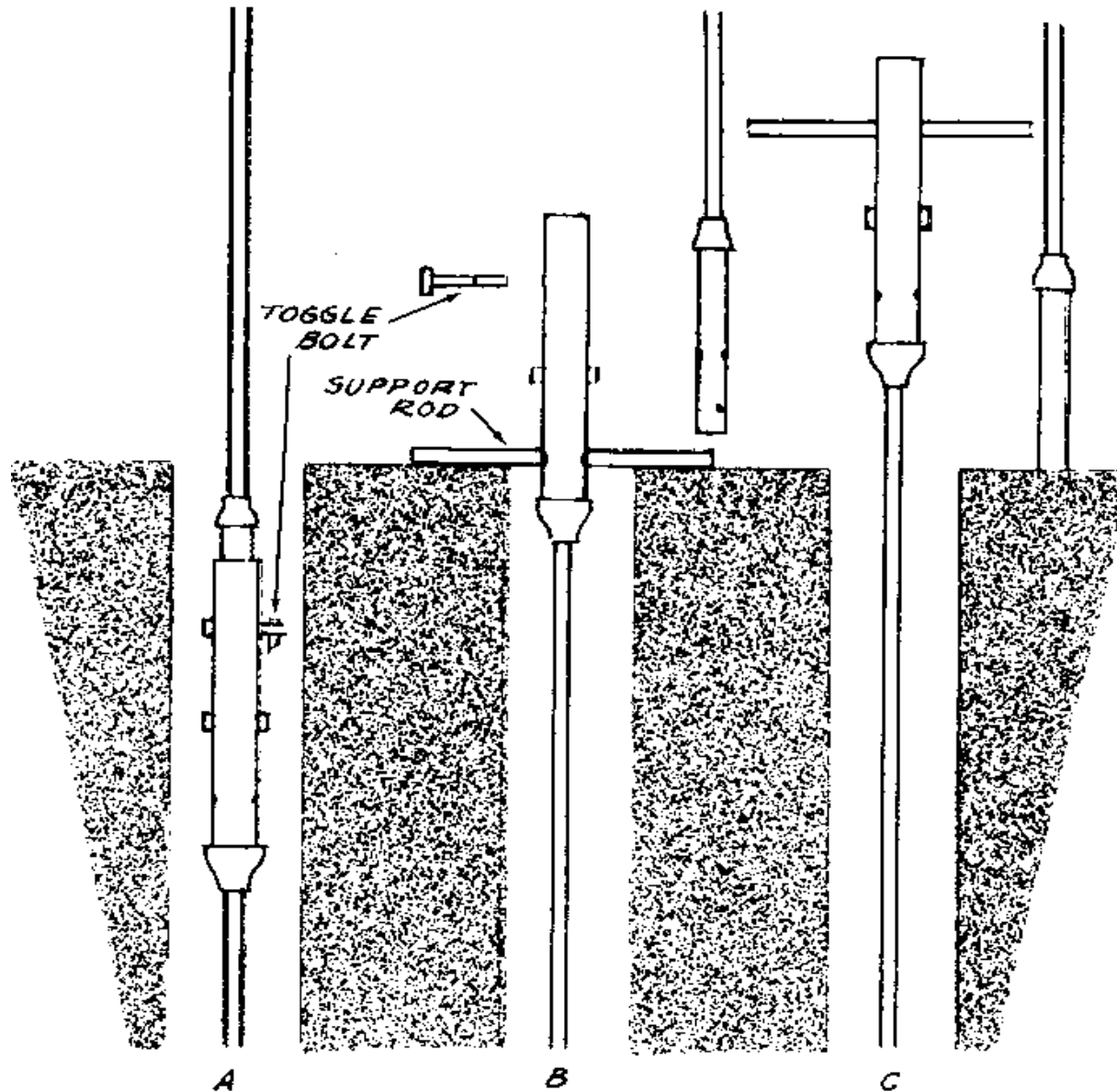

FIGURE 4 JOINT B IN OPERATION

diameter rod through the hole. This allows the whole drill line to rest on it making it impossible for the part still in the well to fall in. Next remove the

toggle bolt, lift out the top section of line and balance it beside the hole.

See

Figure 4B. Pull up the auger, empty it, and replace the section in the hole where

it will be held by the 19mm (3/4") rod. See Figure 4C. Next replace the upper section of drill line. The 10mm (3/8") bolt acts as a stop that allows the holes to

be easily lined up for reinsertion of the toggle bolt. Finally withdraw the rod and

lower the auger for the next drilling. Mark the location for drilling the 8.75mm (13/32") diameter hole in the 32mm (1 1/4") pipe through the toggle bolt hole in the 38mm (1 1/2") pipe. If the hole is located with the 32mm (1 1/4") pipe resting

on the stop bolt, the holes are bound to line up.

Sometimes a special tool is needed to penetrate a water-bearing sand layer, because the wet sand caves in as soon as the auger is removed. If this happens a perforated casing is lowered into the well, and drilling is accomplished with an auger that fits inside the casing. A percussion type with a flap, or a rotary type

with solid walls and a flap are good possibilities. See the entries describing these

devices. The casing will settle deeper into the sand as sand is dug from beneath it. Other sections of casing must be added as drilling proceeds. Try to penetrate

the water bearing sand layer as far as possible (at least three feet-one meter). Ten feet (three meters) of perforated casing embedded in such a sandy layer will provide a very good flow of water.

Tubewell Earth Auger

This earth auger (Figure 5), which is similar to designs used with power drilling

fig5x22.gif (600x600)

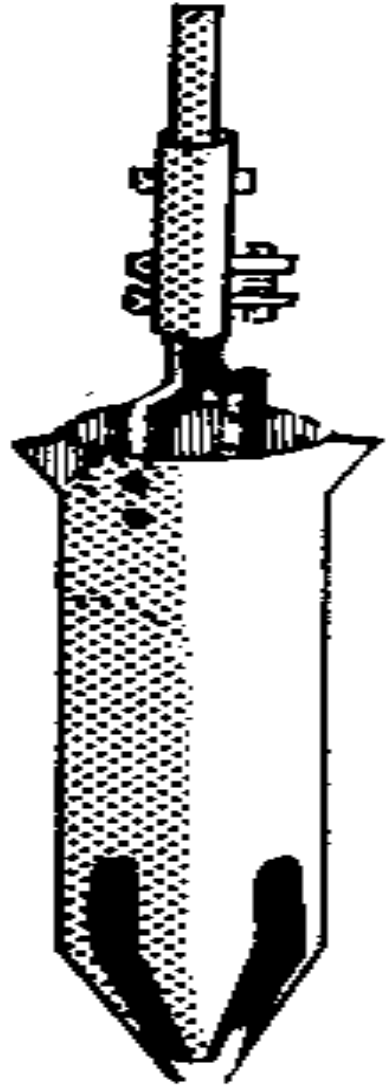

FIGURE 5
TUBEWELL EARTH AUGER

equipment, is made from a 15cm (6") steel tube.

The auger can be made without welding equipment, but some of the bends in the pipe and the bar can be made much more easily when the metal is hot (see Figure 6).

fig6x23.gif (600x600)

FIGURE 6

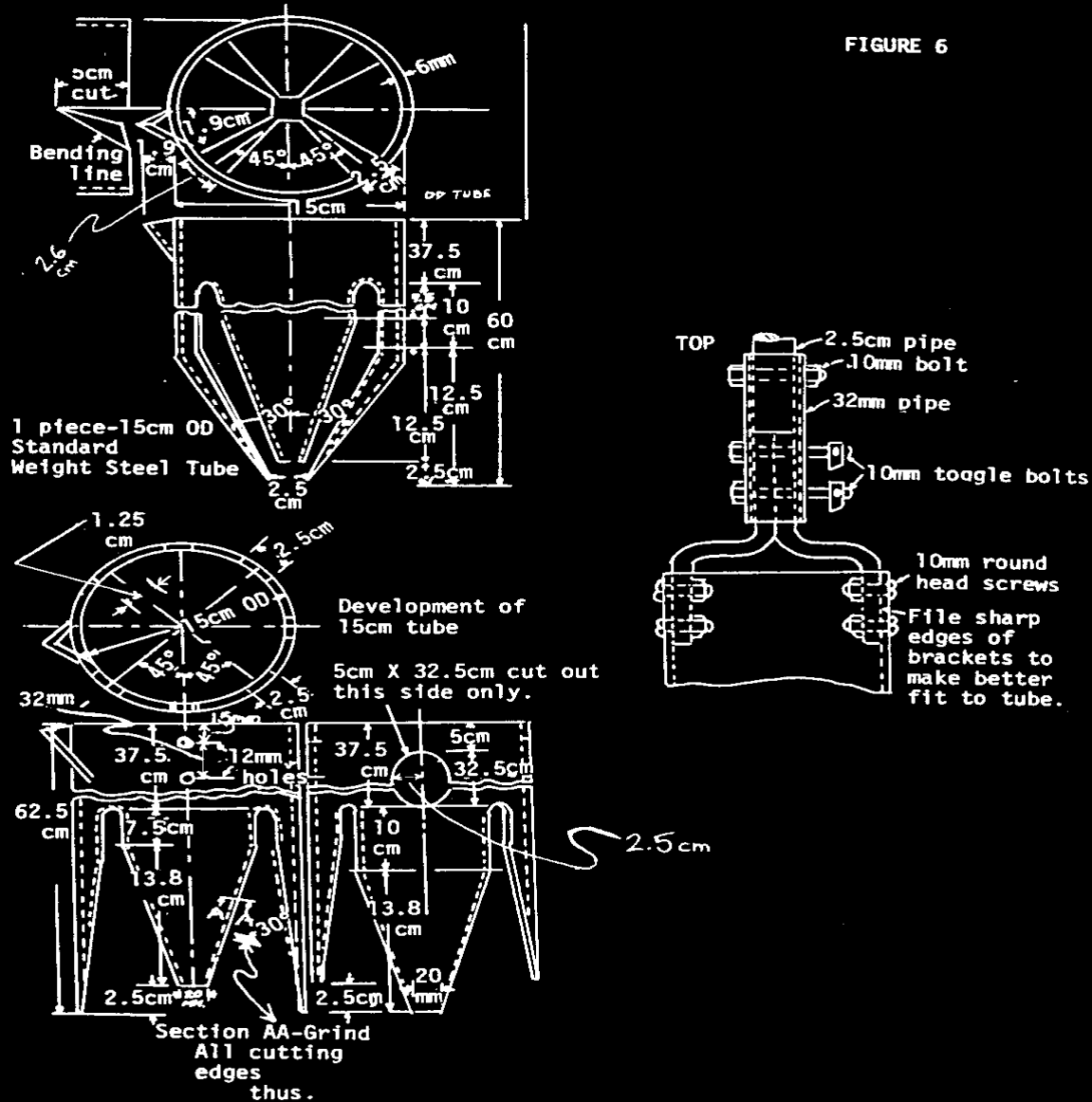

An open earth auger, which is easier to empty than this one, is

better suited for some soils. This auger cuts faster than the Tubewell Sand Auger.

Tools and Materials

Galvanized pipe: 32mm (1 1/4") in diameter and 21.5cm (8 1/2") long
Hexagonal head steel bolt: 10mm (3/8") in diameter and 5cm (2") long, with nut
2 hexagonal head steel bolts: 10mm (3/8") in diameter and 9.5cm (3 3/4") long
2 Steel bars: 1.25cm x 32mm x 236.5mm (1/2" x 1 1/4" x 9 5/16")
4 Round head machine screws: 10mm (3/8") in diameter and 32mm (1 1/4") long
2 Flat head iron rivets: 3mm (1/8") in diameter and 12.5mm (1/2") long
Steel strip: 10mm x 1.5mm x 2.5cm (3/8" x 1/16" x 1")
Steel tube: 15cm (6") outside diameter, 62.5cm (24 5/8") long
Hand tools

Source:

U.S. Army and Air Force. Wells. Technical Manual 5-297, AFM 85-23. Washington, D.C.: U.S. Government Printing Office, 1957.

Tubewell Sand Auger

This sand auger can be used to drill in loose soil or wet sand, where an earth auger is not effective. The simple cutting head requires less force to turn than the Tubewell Earth Auger, but it is more difficult to empty.

A smaller version of the sand auger made to fit inside the casing pipe can be used to