



# Treadle Pump

Human-powered low-cost pump designed to lift shallow water sources for irrigation.







**What is Treadle Pump**



**Treadle Pump in Action**



**Benefits of Treadle Pumps**



**Components and Materials**



**Treadle Pump Installation**

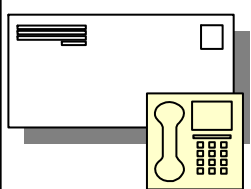

**Contact Us**



**Technical Brief**



## What Is a Treadle Pump

A treadle is a lever device pressed by the foot to drive a machine, in this case a pump. The treadle pump can do most of the work of a motorized pump, but costs considerably less to purchase. Because it needs no fossil fuel (it is driven by the operator's body weight and leg muscles), it can also cost less to operate than a motorized pump. Because leg muscles tire less than arm muscles, it can also be used by the farmers for longer. The treadle pump can greatly increase the income that farmers generate from their land, both by extending the traditional growing season and by expanding the types of crops that can be cultivated.





# Treadle Pump in Action

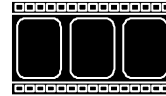





## Benefits of the technology

### Main Highlights

- High water output
- Easy to operate
- Affordable
- Appropriate and attractive to smallholders
- Zero fuel cost for operation
- Can be installed locally
- One year warranty





# Components and Materials Required

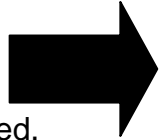

For a typical installation of treadle pump using hand-sludge drilling methods the following materials are required.

S No	Description	Quantity / Unit	Remarks
A: Commercial Materials			
1	Pump head Set (Pump head, Piston, Axle Rod and Plunger pin)	1 Set	
2	1.5" Dia. HDPE or PVC Pipe	40 - 80 ft	Depends on the depth of aquifer
3	1.5" Dia. GI Pipe	2 - 4 ft	
4	Filter net	6 x 3 ft	
5	Plastic ropes	20 ft	
6	½" shoe nails	100 gm	
7	Thread tape	1 Roll	
8	Solvent cement	100 ml	For PVC pipe case
B: Local Materials			
1	Bamboo / Wood	2 pcs	If wood is used: 4 pc 7 ft long log (3" x 4")
2	Anchor Plank	1 ft x 1 ft	
3	¼" size gravel	2 ft <sup>2</sup>	For gravel pack
4	Brick or flat stone	2 pcs	
6	Rope (1 cm dia)	10 ft	
7	Water	500 –1000 Litres	



# Treadle Pump Components

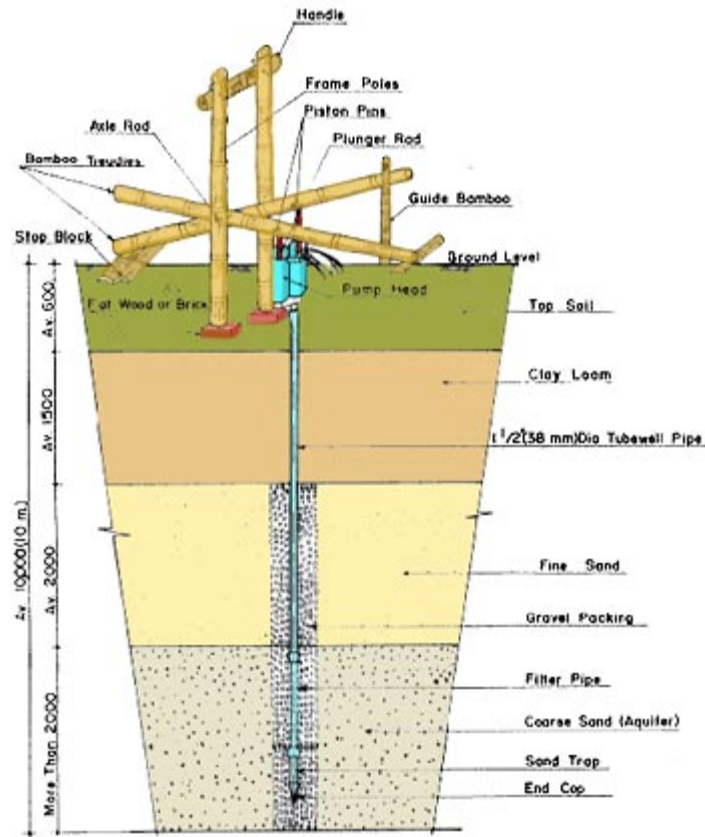



## Contact Us

This technical brief was created in 2010 based on documents produced by Practical Action Nepal.

### **Practical Action Bangladesh**

House 12/B, Road 4

Dhanmondi

Dhaka- 1205, Bangladesh

Tel: +880 (0) 2-8650439, 9675236, 9675243

Fax: +880 2 9674340

Email: [practicalaction@practicalaction.org.bd](mailto:practicalaction@practicalaction.org.bd)

Practical Action is a development charity with a difference. We know the simplest ideas can have the most profound, life-changing effect on poor people across the world. For over 40 years, we have been working closely with some of the world's poorest people - using simple technology to fight poverty and transform their lives for the better. We currently work in 15 countries in Africa, South Asia and Latin America.



## TREADLE PUMPS

A treadle pump is a human-powered low-cost pump designed to lift shallow water sources for irrigation.

A treadle is a lever device pressed by the foot to drive a machine, in this case a pump. The treadle pump can do most of the work of a motorized pump, but costs considerably less to purchase. Because it needs no fossil fuel (it is driven by the operator's body weight and leg muscles), it can also cost less to operate than a motorized pump. Because leg muscles tire less than arm muscles, it can also be used by the farmers for longer. The treadle pump can greatly increase the income that farmers generate from their land, both by extending the traditional growing season and by expanding the types of crops that can be cultivated.

The treadle pump can draw water from up to 7.5m below the surface and has a maximum flow rate of 18m<sup>3</sup> per hour. These are very approximate, and should only be taken as a rough guide. As the lift height increases, flow rate falls so at a maximum lift, the actual flow rate will be much less than the maximum flow rate.

Low-cost treadle pumps have been developed in Nepal, under the guidance of Practical Action. Most of the parts are manufactured locally, so it also brings much needed income to the local economy. The equipment is basically developed for irrigation of small land area (2000-3000m<sup>2</sup>.) where home labour is easily available.

The pump mechanism has two cylinders with piston and check valve assemblies. The treadle action creates alternate strokes in the two pistons that lift the water in pulses. Using twin cylinders means that the water output is semi-continuous, making the treadle pump more efficient than a single cylinder pump such as a hand pump.

The superstructure is erected by using bamboo or wooden poles. It consists of two horizontal treadles and two vertical poles. A short guide pole is installed between the treadles to prevent collision.



Figure 1: Bamboo treadle pumps are used for irrigation in Nepal.  
Photo: Practical Action / Sandra Gibson.

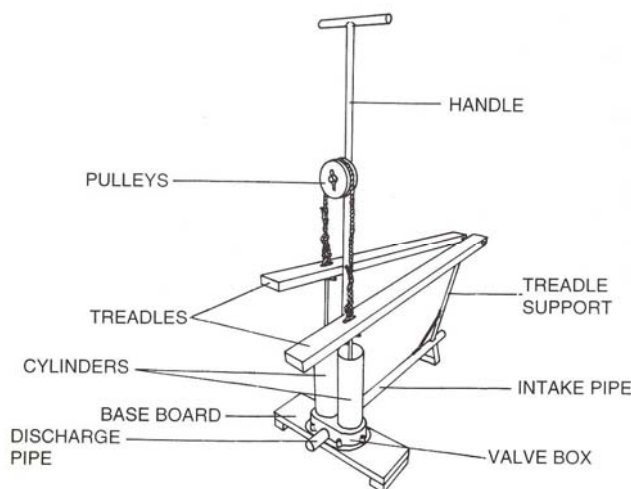

Figure 2: Image from How to Make and Use the Treadle Irrigation Pump. Illustration: Practical Action Publishing.

technical brief



In Nepal, the field tests showed an average flow rate of 3.3m<sup>3</sup> from a depth of 4-5m.

Standard treadle pumps are suction pumps. Most treadle pumps manufactured in Africa are pressure treadle pumps, a modification to the original design that means water is forced out of the pump under pressure. Pressure treadle pumps are more versatile, as they allow farmers to pump water uphill, over long distances, or to elevated tanks.

The treadle pump was originally researched and developed in Bangladesh in the early 80s. In a period of 15 years nearly 2 million pumps were disseminated in Bangladesh, India, Nepal and other countries of Asia and Africa. In Nepal, the treadle pump was introduced by International Development Enterprises (IDE) during the early 90s. By 2005 more than 95000 farmers had adopted treadle pumps. Various studies have shown that treadle pumps generate \$100-\$500 additional household income for rural farmers.

The treadle pump is a low investment technology making it affordable to larger numbers of rural farmers.



Video 1: Using the bamboo treadle pump in Kapilvastu, Nepal. Video: Practical Action Nepal.

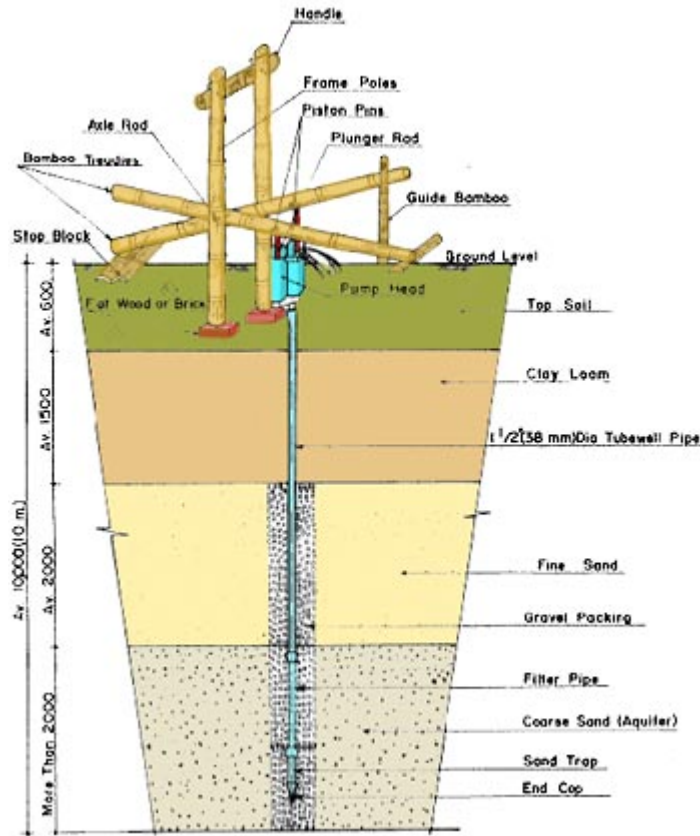

Figure 3: Sectional view of an installed treadle pump.

IDE has an approach to create market for the technology and benefit rural poor through their participation in the market systems.

More than 4 types of treadle pump have been developed. The most popular, simple and low cost version is the 3.5" cylinder diameter bamboo treadle pump, which Practical Action adopted for its work in Nepal. Details of which are described below.

# technical brief

## Main Highlights

- High water output
- Easy to operate
- Affordable
- Appropriate and attractive to smallholders
- Zero fuel cost for operation
- Can be installed locally
- One year warranty

**Suitability and Cost for Installation**

- Recommended depth of pumping: up to 22 ft (exceptionally up to 25 ft)
- Water Discharge: 0.8 - 1.0 litres per second (depends on the depth of water and power of the operator)
- Irrigable Land by one pump: 2000-3000m<sup>2</sup> (depends on soil type and aquifer type)
- Size of the tube well: 1.5 Inch
- Cost of Installation under sludger drilling at a depth of 40 ft
  - Pump head: \$9
  - Pipe & Filter: \$20
  - Installer's Service fee: \$ 8
  - Local materials / labour: \$ 6

Total: \$43

- Operation and Maintenance cost: \$ 0.8 per year.

**Technical Components**

The completely installed treadle pump has essentially three parts.

- Pump head with Piston set
- Superstructure and
- Tube-well pipe with filters

The pump head consists of a twin barrel connected by a junction box in one end. The barrels are made of a 16BG mild steel sheet metal. A check valve is housed at the bottom of the cylinder. The piston set is made of 10mm diameter mild steel rod which has two round discs at one end kept 10mm apart by a PVC bucket washer which is housed between the discs. The other end of the rod is connected with the treadle.

The superstructure is erected by using bamboo or wooden poles. It consists of two horizontal pedals and two vertical poles as shown in the picture. A dwarf pole (Guide) is installed between the pedals to prevent the collision of pedals. For tubewell the most commonly used material is 1.5" plastic pipe. Under hard sub surface conditions GI pipes may be required. Bamboo tube-wells are also used occasionally.

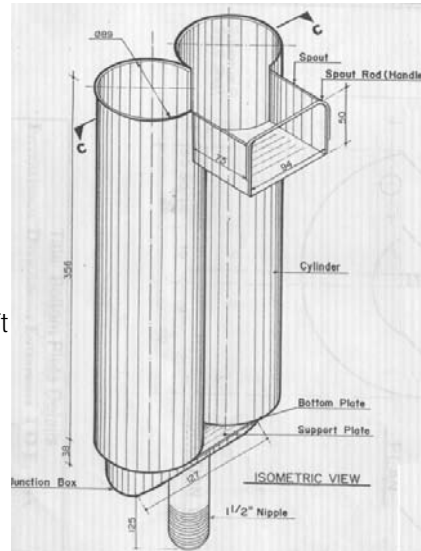

Figure 4: The piston design.



Figure 5: The fabricated cylinder.



Figure 6: Farmers, from Mainhiya Village Development Committee, installing a treadle pump for irrigation. Video: Practical Action Nepal.

technical brief

### Materials required for a Treadle Pump Installation

For a typical installation of treadle pump using hand-sludge drilling methods the following materials are required.

S No	Description	Quantity / Unit	Remarks
A: Commercial Materials			
1	Pump head Set (Pump head, Piston, Axle Rod and Plunger pin)	1 Set	
2	1.5" Dia. HDPE or PVC Pipe	40 - 80 ft	Depends on the depth of aquifer
3	1.5" Dia. GI Pipe	2 - 4 ft	
4	Filter net	6 x 3 ft	
5	Plastic ropes	20 ft	
6	½" shoe nails	100 gm	
7	Thread tape	1 Roll	
8	Solvent cement	100 ml	For PVC pipe case
B: Local Materials			
1	Bamboo / Wood	2 pcs	If wood is used: 4 pc 7 ft long log (3" x 4")
2	Anchor Plank	1 ft x 1 ft	
3	¼" size gravel	2 ft <sup>2</sup>	For gravel pack
4	Brick or flat stone	2 pcs	
6	Rope (1 cm dia)	10 ft	
7	Water	500 - 1000 Litres	

### References and Further Reading

- Case studies: [the impact of treadle pumps in Nepal](#)
- Video: [the story of Phool Kumari](#)
- *Treadle Pumps Transform Rural Life in Nepal Terai* Appropriate Technology, Vol. 31, No 4, Dec 2004, Research Information Ltd, UK, 2004, ISBN: 0305 0920
- *Treadle Pumps – The Cambodian Experience* Breen, M., Waterlines Vol. 14 No 4, April 1996, ISBN 0262 8104(ed)
- *Treadle Pumps for Irrigation in Africa* Knowledge Synthesis Report No 1 - October 2000, Kay M, Brabben T., Food and Agriculture Organization (FAO) - International Programme for Technology and Research in Irrigation and Drainage, Italy, 2000, ISBN 1607-6613  
[http://www.fao.org/documents/show\\_cdr.asp?url\\_file=/DOCREP/005/X8293E/X8293E00.HTM](http://www.fao.org/documents/show_cdr.asp?url_file=/DOCREP/005/X8293E/X8293E00.HTM)
- *Creating Markets with the Poor: Selling Treadle Pumps In India* IIED Gatekeeper Series No 107, van Steenberg F W, International Institute for Environment and Development (IIED), UK, 2003, ISBN 1357-9258  
[http://www.iied.org/sarl/gatekeepers/gk\\_abs/abs101\\_110.html#103](http://www.iied.org/sarl/gatekeepers/gk_abs/abs101_110.html#103)
- *How to Make and Use the Treadle Irrigation Pump* by Carl Bielenberg and Hugh Allen, ISBN 9781853393129
- [http://www.studio-international.co.uk/studio-images/design\\_for\\_change/bamboo\\_b.asp](http://www.studio-international.co.uk/studio-images/design_for_change/bamboo_b.asp)
- [http://www.akvo.org/wiki/index.php/Treadle\\_pump](http://www.akvo.org/wiki/index.php/Treadle_pump)
- <http://treadle.pump.googlepages.com/buildyourowntreadlepump>

### Others involved in treadle pump technology

#### International Development Enterprises (IDE)

10403 West Colfax  
Suite 500  
Lakewood, Colorado 80215  
Tel: 303-232-4336  
Fax: 303-232-8346  
Email: [ide@ideorg.org](mailto:ide@ideorg.org)

Previously known as Appropriate Technology International who developed a treadle pump design which was described in the publication produced by Practical Action Publishing.

*How to Make and Use the Treadle Irrigation Pump* by Carl Bielenberg and Hugh Allen, ISBN

1 85339 312 6, 1995.

IDE introduced low-cost irrigation pumps to South Asia.

<http://www.ideorg.org/OurTechnologies/TreadlePump.aspx>

[Click here to know about IDEI Treadle Pump Programme](#)

#### Treadle Pumps

Features of 3.5 inch treadle pump (metal barrels) with metal treadles

- It has a 3.5-inch barrel diameter.
- Made of sheet metal, the pump weighs approximately 14 kg.
- It is ideal for lifting water from water table depth ranging from 15 feet to 20 feet (maximum lift 25 feet).
- Water output is approximately 0.8 to 1.25 litres per second.

[3.5 inch metal treadle pump \(metal barrels\)](#)

[5 inch metal treadle pump \(metal barrels\)](#)

[3.5 inch bamboo treadle pump \(metal barrels\)](#)

[5 inch concrete treadle pump \(PVC Sleeves\) with wooden pedals](#)

[3.5 inch Surface Treadle Pump \(STP\)](#)

[Rope & Washer Pump](#)

Features of the [Pressure Pump](#)

- The Pressure Treadle Pump is a variation on the standard treadle pump that allows water to be lifted above the level of the pump itself. This greatly increases the versatility of the pump:
- water can be lifted to elevated plots of land
- It can be pumped through hoses over long distances (up to 500 m)
- It works with total head 55feet with maximum 20feet suction lift.
- It can be used to fill the elevated tanks of drip and sprinkler irrigation systems.
- The discharge output is 3000-5000 liters per hour depending upon the depth.

The Pressure Treadle pump retains the advantages of the standard Treadle Pump, including low cost (albeit slightly more expensive than the standard version), efficient foot-powered operation, locally manufactured, easily maintained, and the ability to generate significant additional income for smallholders.

- It is a double cylinder and double acting model, both downward stroke and upward stroke delivers water and optimum utilization of energy spent is achieved.
- A portable self-contained unit sits at ground level.
- Flexibility in installation, it can be moved from one location to another, without any permanent installation on a single well.

# technical brief

**Kickstart**

P.O. Box 64142

Nairobi 00620

Kenya

Tel/Fax: +254-20 3740175

E-mail: [kickstart@kickstart.org](mailto:kickstart@kickstart.org)Website: <http://www.kickstart.org/>

Kickstart is an International NGO that designs, develops and promotes technologies for the use in small-scale enterprises in East Africa. Kickstart was formally called ApproTEC - Appropriate Technologies for Enterprise Creation.

The Super MoneyMaker Pressure Pump was launched in response to a demand by farmers for a pump that can push water uphill as well as pulling it up from the source. This means it is suitable for use on steeply sloping land where the water source may be at the bottom. This pump can draw water from 23 feet (7m) and has a total pumping head of 46 feet (14m). It can be used to irrigate up to 2 acres of land.

**Haiti Fund Inc.**

P.O. Box 1075

New Bern, NC 28563-1075

USA

[jvw.haitifund@gmail.com](mailto:jvw.haitifund@gmail.com)[http://haitifundinc.org/news/articles/treadle\\_pump/treadle\\_pump\\_design.html](http://haitifundinc.org/news/articles/treadle_pump/treadle_pump_design.html)

Haiti Fund, Inc., is the parent organization for the COMPREHENSIVE DEVELOPMENT PROJECT (CODEP). Haiti Fund Inc. was formed as a non-profit corporation under the laws of the State of North Carolina in 1990.

<http://treadlepump.blogspot.com/> A means of documenting and communicating the steps towards development of a treadle pump for use in Haiti.

<http://sites.google.com/site/treadlepump/buildyourowntreadlepump> For those interested in building their own treadle pump there is a site called *Build Your Own Treadle Pump*, offering free plans and instructions for the CODEP treadle pump.

This technical brief was created in 2010 based on documents produced by Practical Action Nepal.

**Practical Action Bangladesh**

House 12/B, Road 4

Dhanmondi

Dhaka- 1205, Bangladesh

Tel: +880 (0) 2-8650439, 9675236, 9675243

Fax: +880 2 9674340

Email: [practicalaction@practicalaction.org.bd](mailto:practicalaction@practicalaction.org.bd)

Practical Action is a development charity with a difference. We know the simplest ideas can have the most profound, life-changing effect on poor people across the world. For over 40 years, we have been working closely with some of the world's poorest people - using simple technology to fight poverty and transform their lives for the better. We currently work in 15 countries in Africa, South Asia and Latin America

# technical brief