

TECHNICAL
43
RELEASE



Animal Cart Programme

Wheel Spanner for Animal Carts

Development Technology Unit, Department of Engineering, University of Warwick, Coventry, CV4 7AL UK, tel: +44 (0)203 523523 extn 2339, fax: +44 (0)203 418922, email: esceo@eng.warwick.ac.uk
KENDAT, PO Box 61441, Nairobi, Kenya, tel/fax: +254 2 766939, email: kendat@africaonline.co.ke

Figure 1: spanner for wheel nuts made from round and flat steel bar and welding.

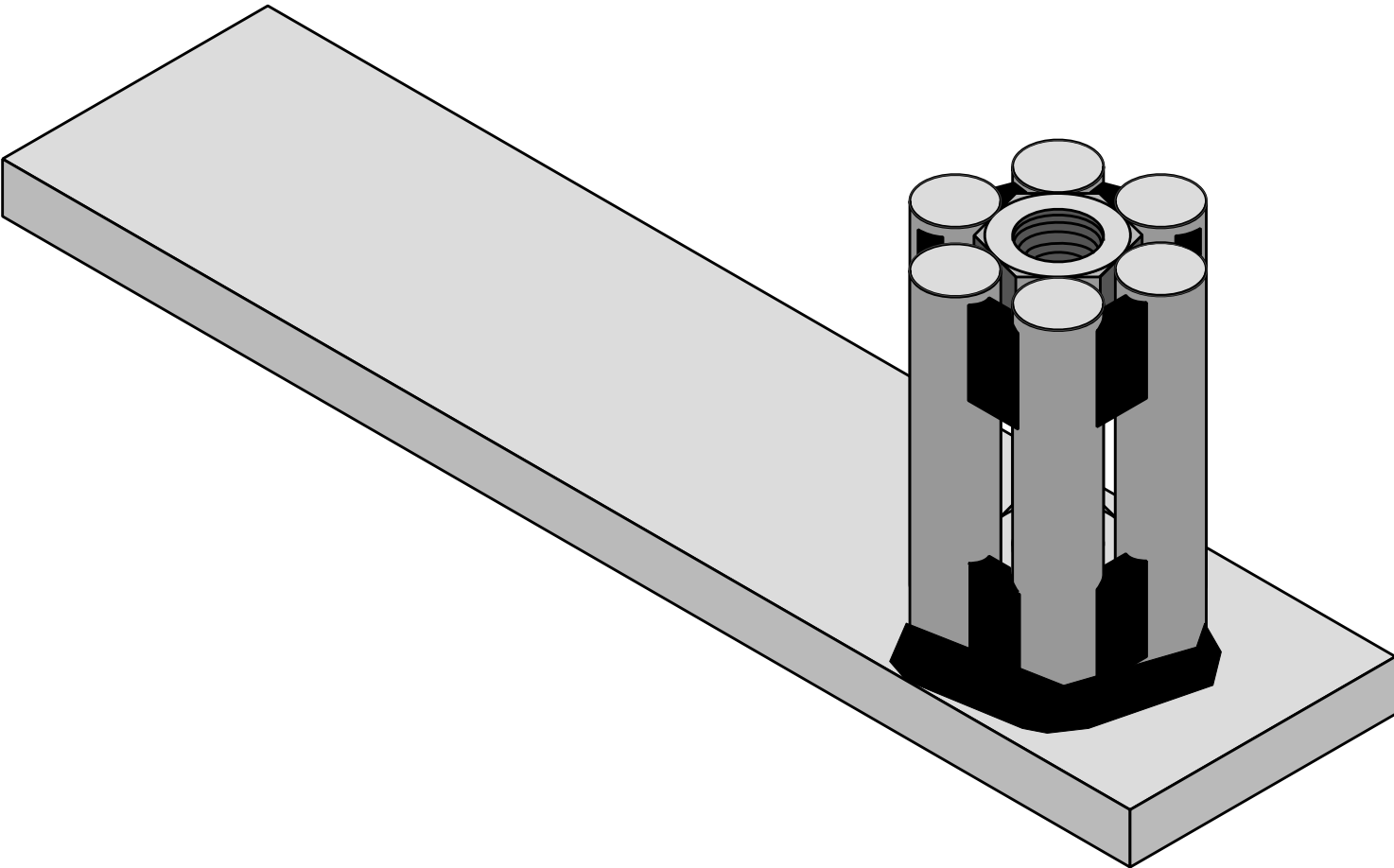

Wheel Nut Spanner for Animal Carts.

Introduction

In this booklet we tell you how to make a spanner for M12 wheel nuts from round bar and a bit of welding.

You should find that you can make a spanner for less than £1 and you can do it in only an hour or less.

The only tools which you must have are a simple welder, a hacksaw, and a hammer.

Cutting list and costs

Table 1 shows a cutting list for a wheel - recent prices of materials in Kenya are shown converted into £UK.

Construction step by step

- 1) Cut the round bar into six 50 mm lengths. File the ends square if you are not good at sawing accurately.
- 2) Cut some strips of thin steel from a tin or drinks can. The strips should be about 65 mm long and 10 mm wide. You will need at least two of them.
- 3) Wrap one of the strips of thin steel around the six sides of an M12 nut. Bend the steel so that it stays in place without

being held.

- 4) Put the nut and steel strip on a flat surface and arrange the round bars around it as shown in Figure 2.
- 5) Put a pipe clip around the six rods outside the nut and tighten the clip so that it grips the nut and steel strip tightly inside the rods. You cannot easily get a pipe clip use a piece of wire to bind the rods together.
- 6) Bend a second steel strip around a nut and put it and the nut inside the rods at the other end. Put another pipe clip around them. Check that all is square and straight.
- 7) Carefully weld the six rods together using small (tack/ spot) welds. When you have it all joined together you can remove the nuts and steel strip and weld heavily to join it all together strongly. You do not need to weld all the way along the rods, a good weld at each end and on in the middle is all that is needed.

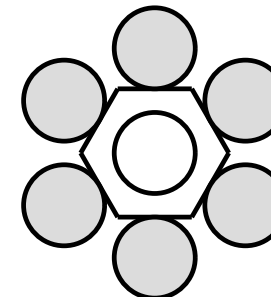

Figure 2: arranging round bars around nut.

- 8) Make a handle from a piece of flat bar or square pipe and weld it onto one end of the spanner to make a handle.
- 9) You've finished it!

DTU cart developments

The DTU has been working on new designs of carts and all their components to bring down their costs and make things more locally manufacturable. It has designs for bodies, wheels, hubs, bearings and animal harness all available from DTU as Technical Releases.

Drawing

You will find a drawing of the wheel on the next page.

TABLE 1: materials for wheel spanner.

| component | material | # lengths reqd [#*mm] | total material for two wheels [mm] | cost [UK£] |
|-----------------------|------------------------------|--------------------------|--|---------------|
| wheel studs | 50xM12 nuts and bolts | 8 | 8 | 2.08 |
| wheel stud struts | 6 x 40 flat bar | 8 x150 | 1200.00 | 0.90 |
| axles | 1-½" BSP malleable iron pipe | 2 x 1500 | 3000.00 | 8.23 |
| small timber discs | 150x25mm timber | 8 x 360 + 8 x 200 | 4480.00 | 1.47 |
| large timber discs | 150x25mm timber | 8 x 580 + 8 x 400 | 7840.00 | 2.57 |
| scrap rubber car tyre | size 185x14 | 2 reqd | 2 reqd | 4.00 |
| | TOTAL | | | 19.26 |

Acknowledgements

The DTU is grateful to the DFID (British Government) for the financial support necessary to carry out the research and development project under which this product was developed.

The DTU would also like to thank Dr Pascal Kaumbutho of KENDAT in Kenya and Mr Joseph Mugaga of TOCIDA in Tororo, Uganda for their very considerable help with this project. A large number of other people and organisations have contributed to the success of the project, most notably Mr Anthony Ndungu in Kajiado Kenya, Mr JD Kimani in Kikuyu Kenya and Mr Joseph Gitari in Wanguru Kenya in whose workshops most of the development work of this project was performed. Thanks are due also to Mr Stanley Lameria in Kajaido, Mr Patrick Gitari in Wanguru and Mr Mathew Masai in Machakos for their assistance.

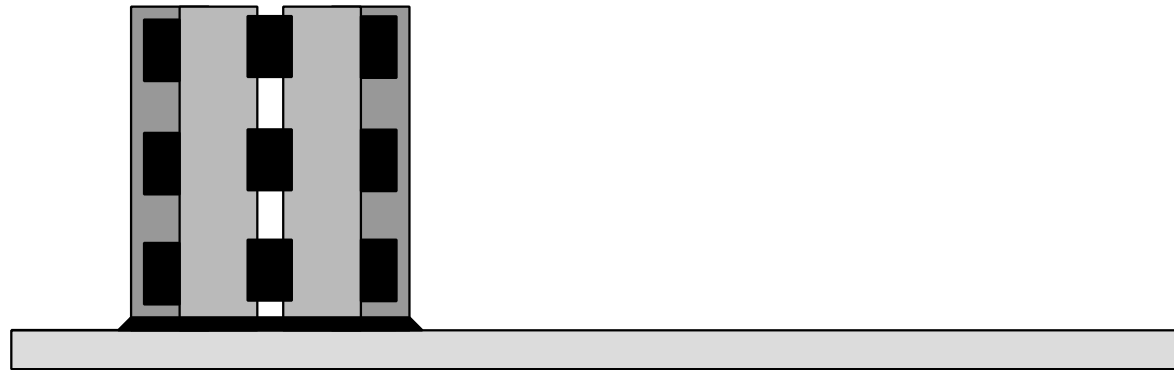

Line of nut (remove from spanner)

General Arrangement

| | | | | |
|-------|---------|------------------------------------|----------|-----|
| Scale | 20mm | Title SPANNER FOR WHEEL NUTS | Drawn by | CEO |
| Date | 16-4-99 | | Dwg No. | 1/1 |