

➔ **Village Electrification (SKAT, 1992, 128 p.)**

(introduction...)

The foreword

Acknowledgment

Introduction

Part 1: Determined entrepreneurs, sustainable development

(introduction...)

1. Planning for private sector involvement

2. A very brief history of electrification

3. A look at current events

4. Aspects of successful rural electrification

Part 2: Generators

1. Synchronous generator

2. IMAG, using induction motors as asynchronous generators

Part 3: Electrical control systems

(introduction...)

1. Fundamental principles of electrical control systems





















2. A concept for standardized electrical control systems

3. Specific problems with isolated, rural electrification schemes

Part 4: Power factor correction

(introduction...)



-  **1. Phasor diagram**
-  **2. The power factor in isolated grids**
-  **2. Power factor in isolated grids**
-  **3. Power factor correction**
-  **4. Measurement of the pf**
-  **5. Calculation examples for the compensation capacitance**
-  **6. Summary, rules, recommendations:**
- Part 5: Earthing**
 -  *(introduction...)*
 -  **1. Current flow in the ground**
 -  **2. The specific electrical resistance of the ground**
 -  **3. Measurement of the earth resistance**
 -  **4. The Influence of the dig-in depth**
 -  **5. Earth contacts**
 -  **6. The influence of current on the earth resistance**
- Part 6: Distribution systems**
 -  *(introduction...)*
 -  **1. Swer, a low cost rural distribution system using single wire earth return.**
 -  **2. Three phase low voltage lines in small isolated grids**
- Part 7: Commercial engineering**
 -  *(introduction...)*
 -  **1. The initial enquiry**
 -  **2. Terms and conditions for specification, orders and contracts**
 - 

 **3. Limits of responsibility** **4. Tender mechanism** **Part 8: Tariffs & financial evaluation** **(introduction...)** **1. Determine tariffs** **2. Financial evaluation** **3. Example** **Part 9: Connection policy** **(introduction...)** **1. General terms** **2. Application and subscription** **3. Connection fee and cost participation** **4. Level change** **5. Meters and distribution boxes** **6. Meter reading, billing and payment** **7. Sub-supply and sub metering** **8. House installations and wiring** **9. Extraordinary services** **10. Legal terms** **Part 10: Typical application examples** **(introduction...)** **1. Introduction** **2. Namche bazar (category a)** **3. Chame (category b)**

- **4. Syangja (category c)**
- **Part 11: The salleri chialsa venture**
- **(introduction...)**
- **1 Introduction**
- **2. Energy and hydro power**
- **3. The small hydro power sector**
- **4. The history of the salleri chialsa small hydro power project**
- **5. The setting**
- **6. Construction and features of plant and grid**
- **7. Design and technical data**
- **8. Operation**
- **9. Management by a shareholder company**
- **10. Conclusions**



[Home](#) > [ar.cn.de.en.es.fr.id.it.ph.po.ru.sw](#)

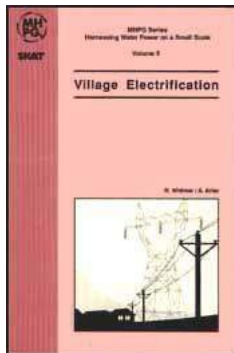

- **Village Electrification (SKAT, 1992, 128 p.)**
- ➔ **(introduction...)**
- **The foreword**
- **Acknowledgment**
- **Introduction**
- **Part 1: Determined entrepreneurs, sustainable development**
- **Part 2: Generators**
- **Part 3: Electrical control systems**
- **Part 4: Power factor correction**
- **Part 5: Earthing**

- Part 6: Distribution systems**
- Part 7: Commercial engineering**
- Part 8: Tariffs & financial evaluation**
- Part 9: Connection policy**
- Part 10: Typical application examples**
- Part 11: The salleri chialsa venture**

Volume 1: Local experience with micro-hydro technology

Volume 2: Hydraulics engineering manual

Volume 3: Cross flow turbine design and equipment engineering

Volume 4: Cross flow turbine fabrication

Volume 5: Village electrification

Volume 6: The heat generator

Volume 7: MHP information package

Volume 8: Governor product information

Volume 9: Micro pelton turbines

Volume 10: Manual on induction motors used as generators

Volume 11: Manual on pumps used as turbines



[Home](#) > [ar](#).[cn](#).[de](#).[en](#).[es](#).[fr](#).[id](#).[it](#).[ph](#).[po](#).[ru](#).[sw](#)

 **Village Electrification (SKAT, 1992, 128 p.)**

➔ **Part 6: Distribution systems**

 *(introduction...)*

 **1. Swer, a low cost rural distribution system using single wire earth return.**

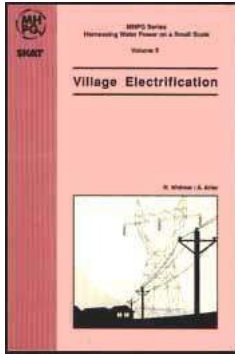

2. Three phase low voltage lines in small isolated grids

Village Electrification (SKAT, 1992, 128 p.)

Part 6: Distribution systems

The first part originates from an article of Mr. Bryan Leyland, Leyland Consultants Ltd, 100 Anzac Ave, Auckland, New Zealand. The second is a contribution of Mr. Hanspeter Prinz, Wadenswil, Switzerland.

1. Swer, a low cost rural distribution system using single wire earth return.

What is called a standard distribution system, is often based on designs for urban areas or national grids. They exceed by far the requirements of a stand alone village electrification scheme. Below the description of an adequate low cost system, developed by the New Zealand engineer Lloyd Mandeno in the 1920s and still today widely used in New Zealand and Australian rural areas.

It is basically a single phase supply (as it is the norm in rural USA) with only one wire and using the earth as the return conductor. This system is commonly known as the Single

Wire Earth Return, SWER, system.

The essential elements of the system are shown in Fig 1. All the voltages are shown for a 22 kV main distribution (and in brackets an 11 kV).

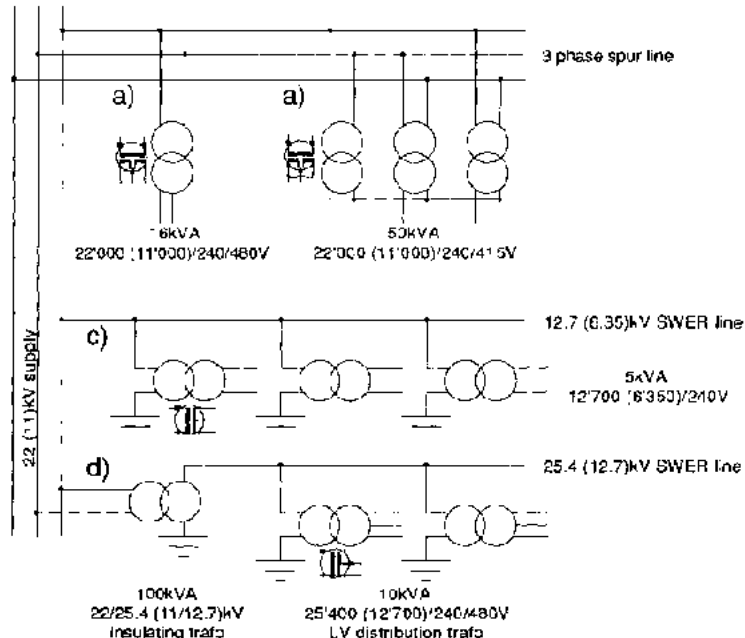

Fig 1 Comparison between several distribution concepts 3 phase system a) single phase (16 kVA) b) three phase (50 kVA) SWER system c) directly tapping the HV line(5 kVA) d) with single phase insulating trafo (100 kVA) - > SWER line (10 kVA)

1.1. High Voltage Lines

1.1.1. Conductors

Conductors for the three phase lines would be either all aluminium or aluminium alloy such as "Silmalec".

For the three phase spur lines either 3/12" galvanized steel wire or 10 or 16 mm² copper equivalent wire would be used.

For main lines (supplying several villages) 16, 35 or 50 mm² would be used .

Conductors for the single wire spurs would be either "Silmalec" or 3/12" galvanized steel wire.

1.1 .2. Poles

Poles can be either of steel or wood. For SWER lines local timber poles should be used if available. Alternatively where transport is difficult and porters are used, poles made from conical sections, nested for transport and fitted together on site, would be very suitable.

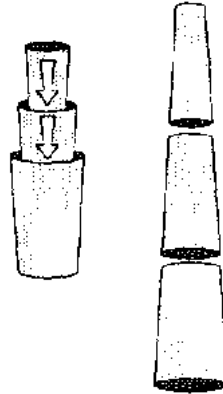

Fig 2 Nestable pole structure

Pole spacing should be as wide as possible, hence wherever possible they should be placed on rises (hills, ridges etc.); for SWER lines, spacing of 150 to 200m is possible.

1.1.3. SWER Spur Lines

Short or lightly loaded SWER spurs would be tapped directly off the three phase line and operate at 1 2.7(6.35)kV to earth (see Fig I c).

Long SWER spurs with loadings in excess of 5070 kVA could be supplied via a 22/25.4 (11/1 2.7) kV insulating transformer (see Fig 1d). This has two advantages: it increases the voltage, consequently reducing the current and the losses, and it limits the extent of the earth return current to the spur line and insulating transformer only.

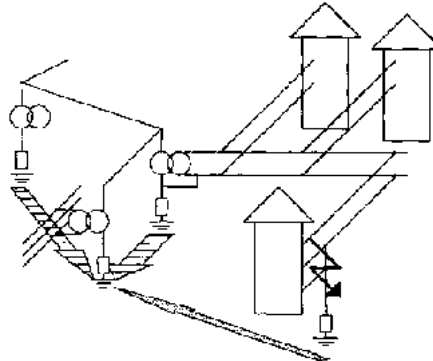

Fig 3 Arrangement of configuration d) (see Fig 1)

It shows the limited extent of the earth return current between the insulation and the LV distribution transformer. In case of a short to earth, earth currents flow of course close to consumers.

SWER spurs would not be designed for a later upgrading to three phase, the shorter spans and stronger poles needed would double the cost of the line. Experience has shown, however, that by the time a three phase supply is needed, the low cost SWER line has more than paid for itself.

1.2. Transformers

1.2.3. Type

Transformers would follow US rather than European practice. They could be rated at 16 kVA for single phase 22 (11)kV (concept a & b in Fig 1). For SWER lines it would be convenient to use ratings of 5 kVA for 12.7 (6.35)kV and 10 kVA for 25.4 (12.7)kV (concept c & d in Fig 1) with one standard dual voltage transformer with only one high

tension bushing. The high voltage winding can be connected to either 25.4 (12.7) or 12.7 (6.35)kV. The dual secondary winding can be connected in series for 240 & 480V at 25.4 (12.7)kV. At 12.7 (6.35)kV, however, only the 480V winding is used (see Fig 4a), which will produce 240V.

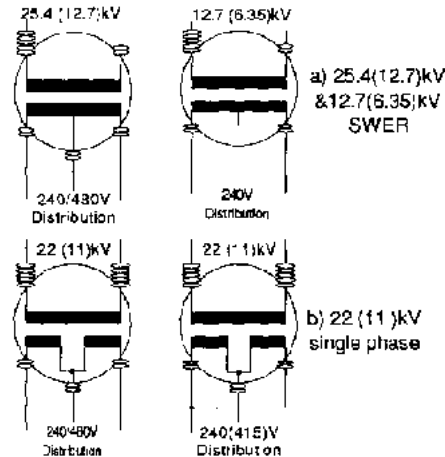

Fig 4 Dual Voltage Transformers.

1.2.2. Construction and Mounting

The SWER transformer would be totally sealed. A surge diverter (arrestor) would be secured to the tank. There would be one HV bushing and three LV bushings; no other tapings! The no load voltage ratio would be 25'400:255/510V.

For installations in remote areas, accessible only with porters (as for instance in the Himalayas) the weight must be kept below 50kg. This might require a rating as low as

10kVA.

Mounting arrangement would follow US practice. The transformers would be secured to a clamp fitted to the pole or simply to a bolt through the pole.

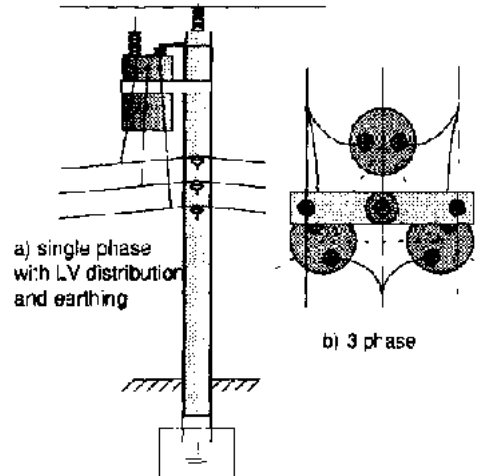

Fig 5 a) Pole mounting of a single phase transformer. b) Symmetrical arrangement of three identical transformers around a pole for a three phase system .

The 22 (11)kV single phase transformer would be similar except that it would have two HV bushings. It would be possible to use three such transformers to give a three phase supply. The secondary winding would be paralleled in this case (refer to Fig 4a). Three transformers can be mounted on a single pole by spacing them equally around it.

1.3. Protection

Every spur line is protected by drop-out fuses. Each transformer would also be protected by fuse and by a tank-mounted surge diverter. Auto reclosers and sectionalizers should be used in areas where lightning is a problem. With the SWER lines, only a single phase unit is needed, so the cost is much reduced.

1.4. Earth Return Currents and Earthing

Injecting currents into the earth is a complex phenomena (see also part: Earthing). In the case of a uniformly conducting soil, the current disperses radially, generating circular equipotential lines. The voltage drops quickly, forming a "potential funnel", and a few meters from the earthing point, the voltage is not elevated anymore. The steep voltage gradient guarantees a short range of disturbance but poses also the risk of considerable voltages between objects within a person's reach. This might be amplified by a good conducting object entering the "potential funnel" (for instance a water pipe). It is advisable to maintain a distributed earthing system with several earthing points on the LV side.

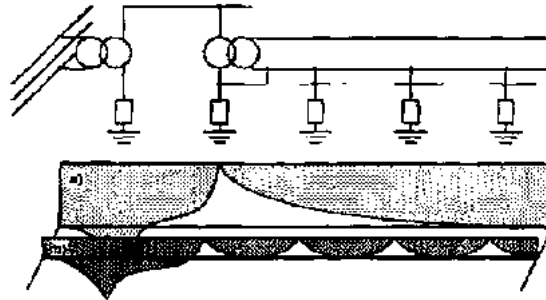

Fig 6 Improvement of the earth potential using several earthing systems. a) 'steep' and 'deep' potential funnel for a single earth at the transformers . b) the obvious betterment using

several earthing systems (for instance at each important consumer's connection).

Where 12.7 (6.35)kV connections are used, the earth currents return to the supply transformer neutral (distribution concept Fig 1 c). To minimize the neutral current the loads must be evenly balanced between the phases. In perfect balance the supply transformer neutral carries no current at all (not so the SWER LV distribution transformers!). If the 12.7 (6.35)kV load were, say, 100 kVA, and the out of balance is 20%, then the current at the supply neutral would still only be 1.5 (3.0)A. This would not cause problems with losses or neutral displacement even if a 60 Ohm neutral resistor were used.

Using a single phase insulating transformer, however, its neutral current will be substantial. For 25.4 (12.7) kV end a rating of 100 kVA the maximum earth return current is 4 (8)A. To keep the earth electrode's voltage at less than 20V the earth resistance mustn't exceed 5 (2.5) Ohm. This voltage is accepted as safe in Australia and New Zealand. It might be a major obstacle to reach earth resistances lower than 10 Ohm. This is, however, essential for a proper SWER system functioning and must be achieved.

At a 10/SkVA distribution transformer, the earth current will be 0.4 (0.8)A. Here the earth resistance mustn't exceed 50 (25) Ohm, which is much less stringent.

In keeping New Zealand practice, the LV neutral earth should be connected to the same electrode as the HV earth. This allows to keep the neutral potential close to the earth potential. But it also adds a substantial risk: if the earth connection is interrupted, the whole LV wiring is on high potential!

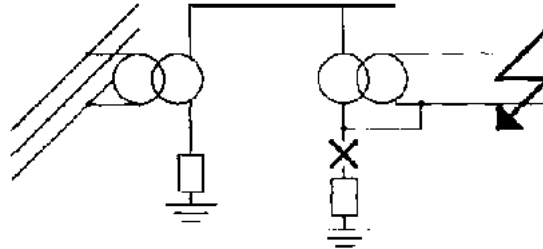

Fig 7 Risk of high tension on the LV distribution.

If the only earthing point is the LV distribution transformer and this connection is interrupted, high tension appears on the low tension side. This risk is reduced when several earthing systems are used.

To minimize this risk, the earth wires down the pole should be duplicated and protected. If steel poles are used, they too should be connected to the earth electrode.

1.5. Insulators

In both Australia and New Zealand, standard 11kV insulators have been used on 11kV SWER lines with complete success. This is probably a result of the clean atmosphere in rural locations combined with the high impulse insulation of wooden crossarms and poles. Where steel poles and crossarms are used, a higher level of insulation might be necessary for 12.7kV SWER lines, so insulators rated for 22kV should be used.

1.6. Electric Motors

US rural distribution is primarily single phase 120/ 240V, and they do not hesitate to use quite large single phase motors (3kW and more). In New Zealand, 2.2kW single phase motors are often used and, in some cases, three phase motors have been connected to a

single phase system by using capacitors to create a third phase. If there is a need to supply a load with large three phase motors, then the revenue it generates should pay for the cost of the light 11kV three phase line needed to supply it. If it doesn't, the consumer can be offered the choice of paying to have the line upgraded or to use diesel engines to drive his equipment.

1.7. Example: Cost Comparison

To show the possibilities of cost reduction by engineering, the following example for a 10 km HV line, 3 km LV distribution for three kampong in rural Malaysia is shown. The costs are based on '87 prices and might have changed considerably, but in this context the relative reduction is important, not its absolute value.

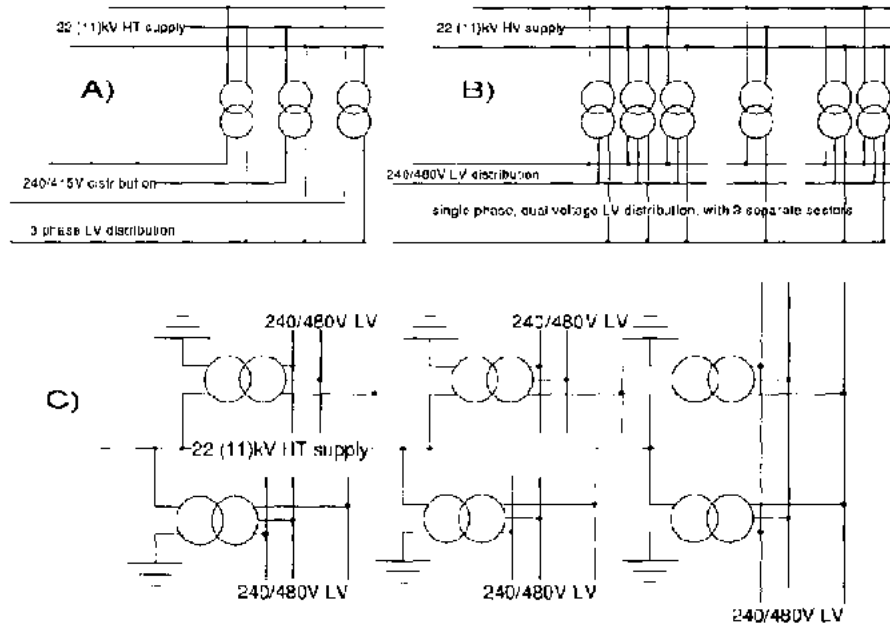

Fig 8 Principle diagram for system A, B and C (corresponds to distribution concept b), a) and c) respectively in fig 1)

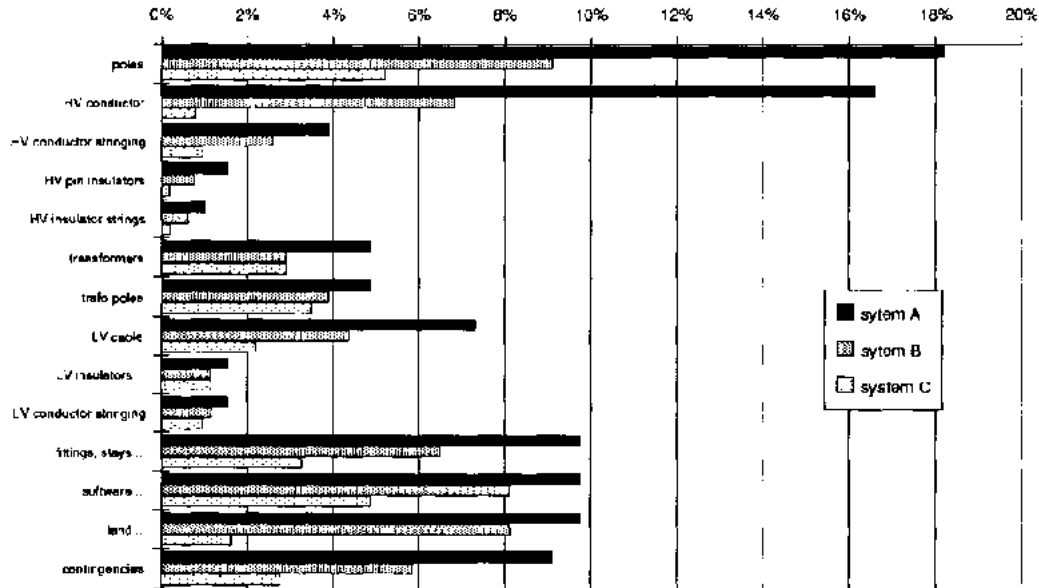

Fig 9 Cost comparison of the three concepts A, B and C. All categories are displayed in percent of System's A total costs.

200 pcs	poles, erected	@ MS	280	56'000
30'000 m	of 100mm2 HV conductor	@ MS/m	1.70	51'000
10 km	HV conductor stringing	@ MS/km	1'200	12'000
600 pcs	HV pin insulators	@ MS	8	4'800
100 pcs	HV tension Insulator strings	@ MS	32	3'200
3 pcs	100 kVA transformers	@ MS	5'000	15'000
3 pcs	2 pole trafo structures	@ MS	5'000	15'000
9'000 m	4 x 150mm2 LV cable	@ MS/m	2.50	22'500

3	km	LV insulators etc	@ M\$/km	1'500	4'800
3	km	LV conductor stringing	@ M\$/km	1'500	4'800
10	km	misc. fittings, stays etc	@ M\$/km	3'000	30'000
1		engineering, surveying, drawing etc.		30'000	30'000
1		land compensation etc		30'000	30'000
		contingencies			28'000
SEB Standard System, 300kVA, 3 phase				total	307'100
				total/km	31'000

100	pcs	poles, erected	@ M\$	280	28'000
30'000	m	of 3x16mm ² HV conductor	@ M\$/m	0.70	21'000
10	km	HV conductor stringing	@ M\$/km	800	8'000
300	pcs	HV pin insulators	@ M\$	8	2'400
60	pcs	HV tension insulator strings	@ M\$	32	1'920
6	pcs	16 kVA transformers	@ M\$	1'500	9'000
6	pcs	1 pole trallo structures	@ M\$	2'000	12'000
9'000	m	3 x 100/50mm ² LV cable	@ M\$/m	1.50	13'500
3	km	LV insulators etc	@ M\$/km	1'200	3'600
3	km	LV conductor stringing	@ M\$/km	1'200	3'600
10	km	misc. fittings, stays etc	@ M\$/km	2'000	20'000
1		engineering, surveying, drawing etc.		25'000	25'000
1		land compensation etc		25'000	25'000
		contingencies			18'000
Low Cost Three Phase System, 96kVA single phase				total	191'020
				total/km	19'000

80	pcs	poles, erected	@ M\$	200	16'000
10'000	m	3/12" steel HV conductor	@ M\$/m	0.25	2'500
10	km	HV conductor stringing	@ M\$/km	300	3'000
80	pcs	HV pin insulators	@ M\$	8	640
20	pcs	HV tension insulator strings	@ M\$	32	640
6	pcs	16 kVA transformers	@ M\$	1'500	9'000

0	pcs	10 kVA transformers	@ MS	1000	9000
6	pcs	1 pole trafo structures	@ MS	1800	10800
9000	m	3 x 50/25mm ² LV cable	@ MS/m	0.75	6750
3	km	LV insulators etc	@ MS/km	1200	3600
3	km	LV conductor stringing	@ MS/km	1000	3000
10	km	misc. fittings, stays etc	@ MS/km	1000	10000
1		engineering, surveying, drawing etc.		15000	15000
1		land compensation etc		5000	5000
		contingencies			8500
SWER, 60kVA, without insulating trafo, concept c)				total	94430
				total/km	9500

Table 1 Costs listed for the three systems AB and C

2. Three phase low voltage lines in small isolated grids

2.1 Three or Four Wire Systems

A three wire system uses only the 3 phase wires (L1, L2, L3). Therefore, only the phase voltages (voltage between two phases) are available. Is the generator delta-connected, the phase voltage is 220V and normal single phase appliances can be connected between any two phase conductors. Three phase motors, however, are not readily available for a 220V phase voltage and would have to be specially wound. This might be the main reason why three wire systems are rarely used in low voltage (LV) systems. Though in high voltage (HV) distribution they are often found because of the obvious benefit: one wire less reduces the conductor costs by 25%.

A four wire system uses three phase wires (L1, L2, L3) and one neutral wire (N or if earthed PEN). There are two different voltages in this system: 380V between the phase wires (L1L2, L1L3 and L2L3) and 220V between any phase and neutral wire (L1N, L2N and L3N). Both 3 phase and single phase appliances can be connected.

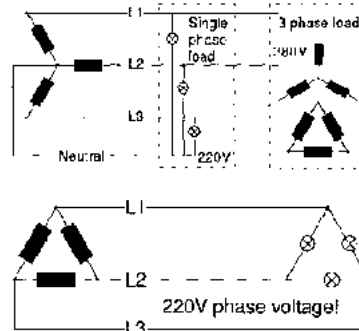

Fig 1 Three and four wire system

2.2 Racks, Poles & Protection

Because of power losses LV overhead distributions are not suitable for long distances. The example at the end of this chapter predicts losses in the distribution line of 6% of the produced energy. This might be 6% of the revenues! If the investments for higher efficiency (HV distribution) cannot be paid with these savings, however, a LV distribution (link power house to village for instance) becomes feasible. For short distances even cables (3 or 4 wires) should be considered. Although expensive, their use avoids any additional costs for poles, insulators, mounting gear... when laid under ground.

An easy and suitable way to mount the LV conductors is a construction called 'rack' mounting. Racks are widely used in Latin-America. One rack is containing (four) equally spaced insulators fixed in a line on a steel frame. Racks can be fixed to poles, walls and ceilings. For instance to avoid costs for additional poles, they can be mounted together with high tension lines, double using the poles.

For an overland distribution without a topping HV line, the top wire in the rack should be

the neutral cum earth wire (PEN conductor) to provide an adequate lightning protection. In populated areas, however, the PEN conductor is the bottom wire to reduce the risk of accidents.

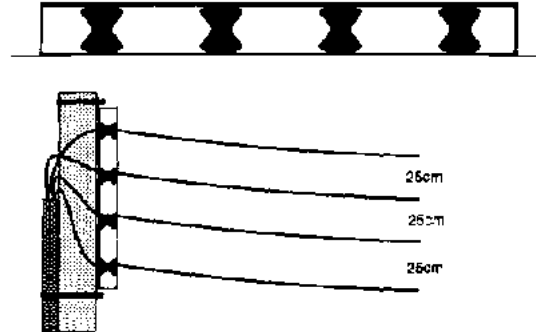

Fig. 2 Rack mounting.

2.2.1 Pole Height and Spacing

The pole height is given by safety regulations and/or considerations. People, animals and vehicles shouldn't get close to wires or any energized structure. Special attention is paid to distributions close to houses (roofs, windows), crossing of streets or footpaths and pasture land.

The average pole spacing is between 40-60m. The conductors are strained until the required sag is achieved. Often this is solely based on the experience of the fitter/lineman. Calculations are not very simple. They are based on a curve called 'catenary' since any perfectly flexible material of uniform mass will hang in the shape of a catenary when suspended between two supporters. For short spans this curve can be approximated with a parabola which simplifies the calculations. A brief collection of the formulas is given

below, details are in the references.

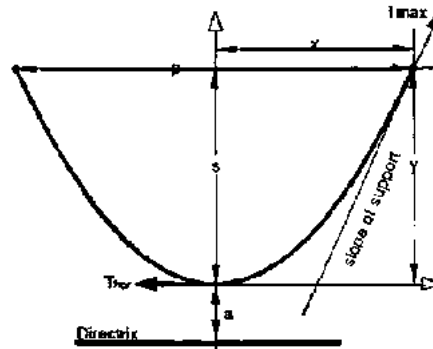

$$\text{Parabola } y = \frac{x^2}{4a}$$

w force per unit length of cable and load

$$L = p + \frac{8s^2}{3p} \quad \text{length of cable}$$

$$T_{hor} = 2 \cdot a \cdot w = \frac{w \cdot p^2}{8s} \quad \text{horizontal tension}$$

$$T_{ver} = \frac{w(3p^2 + 8s^2)}{6p} \quad \text{vertical tension}$$

$$T_{max} = \frac{w \cdot p}{8s} \sqrt{p^2 + 16s^2} \quad \text{maximum tension}$$

$$S(x) = \frac{w \cdot x^2}{2H} \quad \text{sag as a function of } x$$

$$S_{max} = \frac{w \cdot p^2}{8H} \quad \text{maximum sag}$$

Fig 3 Parabolic curve equations

Note: In climates with wide temperature changes, the sag has to be increased to avoid

ripping of the conductors due to thermic contraction.

2.2.2 Surge Arrestors

Atmospheric and switching surge voltages must be neutralized before they can reach and destroy transformers, generators and switch gear. Surge arrestors (absorbers, dischargers) are installed at least at the beginning and at the end of the transmission line. They are designed for 0.8 of the nominal line Voltage U_n .

2.3 Cross Section Calculation for Overhead Conductors

Commonly copper and aluminium conductors are used. Here aluminium ropes (conductors) are emphasized: for the same current the per length weight is only half and aluminum is cheaper. Furthermore, aluminium ropes with a steel core, ACSR (Aluminum Conductor, Steel Reinforced), have approximately the same tensile strength as copper wires.

Some important dates are listed in Tables 1 and 2.

Material	at 20°C	at 40°C	at 60°C	at 80°C	
Al/St	30.0	27.8	25.9	24.2	$m/\Omega mm^2$
Al	35.4	32.8	30.5	28.5	$m/\Omega mm^2$
Cu	56.3	52.1	48.5	45.4	$m/\Omega mm^2$

Table 2 Conductivity for different temperatures

2.3.1 Equivalent Circuit of Overhead Lines

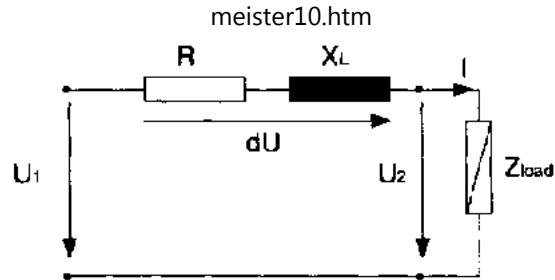

Fig. 4 Simplified equivalent circuit of overhead lines up to 60 kV

The line is described in the equivalent circuit by a resistor and an inductance. Above 60 kV the capacitance between the wires as well as between wires and ground have to be considered. With a current I along the line a voltage drop occurs. At the line's end only a reduced voltage $U_2 = U_1 - DU$ is available. The phase shift φ between U_1 and U_2 is small for short lines and the exact complex calculations can be avoided. A calculation using real values is introduced.

The (real) impedance per length is defined as:

$$f = R_L + X_L \cdot \tan \varphi \quad [\text{W/km}]$$

with:

R_L [W/km] ohmic part of the line impedance

X_L [W/km] reactance of inductive part of the line impedance

φ [rad] phase angle between current and voltage at the load ($\cos \varphi = \text{power factor}$)

2.3.2 Cross Section Calculation

Generally it can be assumed that an overhead line correctly designed for nominal voltage drops, will not overheat. This should be checked, however, because in short cabled distribution systems (typical for LV systems) the cable cross section might be determined by the current capacity. For LV house wiring this is always true.

Size AWG	Total Cross sectional area (mm ²)	# of wires Al/St	diameter of each wire (mm)	Electrical resistance (Ω/km) at 20°C	at 40°C	at 60°C	at 80°C
8	9.77	6'	1.33	3.43	3.70	3.98	4.25
7	12.32	6'1	1.50	2.72	2.94	3.16	3.37
6	15.51	6'1	1.58	2.15	2.32	2.49	2.67
5	19.57	6*	1.89	1.71	1.85	1.98	2.12
4	24.68	6'1	2.12	1.35	1.47	1.58	1.69
3	31.12	6'1	2.38	1.07	1.16	1.24	1.33
2	39.24	6*	2.67	0.85	0.92	0.99	1.05
1	49.48	6'1	3.00	0.68	0.73	0.79	0.84
1/0	62.42	6'1	3.37	0.54	0.58	0.63	0.67
2/0	78.66	6'1	3.78	0.43	0.46	0.50	0.53
3/0	99.20	6'1	4.25	0.34	0.37	0.39	0.42
4/0	125.09	6'1	4.77	0.28	0.30	0.32	0.35

Calculation of the resistance R_T for arbitrary temperatures T : $R_T = R_{20} [1 + \alpha_{20}(T - 20^\circ\text{C})]$
 α_{20} for Al, Al/St and Cu = 0.004 1/K

Table 1 Most important data for Aluminium/Steel ropes (Source: bare aluminium wires & cables, data-sheet, Furakawa, Sao Paulo, Brazil)

Neglecting the Inductivity

$$A = \frac{P \cdot l}{g \cdot \Delta U_n \cdot U_n} \text{ oder } \frac{1}{g \cdot R_L} [\text{mm}^2] \quad (2)$$

with

P [kW] assumed max. Power

l [km] line length

ΔU_n [kV] voltage drop along one phase conductor

U_n [kV] nominal phase voltage

g [m/ Ω mm²] conductivity

R_L [Ω /m] resistance per length

This calculation is correct if:

- the load has a power factor of 1 (ohmic load)
- the supply is DC
- the conductor's cross section is small; $R_L \gg X_L$
(see Table 3)

An approximate calculation for the cross section A .

Including Inductivity

$$X_L = \omega \cdot k \cdot \left[\ln \left(\frac{d}{\sqrt{\frac{A}{\pi}}}} \right) + 0.25 \right] \left[\frac{\Omega}{\text{km}} \right] \quad (3)$$

$$\text{and } d = \sqrt[3]{d_1 \cdot d_2 \cdot d_3}$$

with

$k = 0.0002 \text{ [H/m]}$ a constant

$\omega = 2\pi f \text{ [1/s]}$ angular frequency

$d \text{ [m]}$ geometrical mean of conductor spacings

$A \text{ [m}^2\text{]}$ conductor's cross section

The inductivity reactance X_L can approximately be calculated as.

The cross section A is difficult to calculate if X_L is not zero and is therefore tabulated. Table 3 shows vertically arranged ('racked') wires equally spaced at a distance of 0.25 m.

cabel No	cross section (mm ²)	inductivity (Ω/km)
8	9.77	0.33
7	12.32	0.32
6	15.51	0.31
5	19.57	0.30
4	24.68	0.30
3	31.12	0.29
2	39.24	0.28
1	49.48	0.28
1/0	62.42	0.27
2/0	78.66	0.26
3/0	99.20	0.25
4/0	125.09	0.25

Table 3 Inductivity for rack mounted lines ($d = 0.31 \text{ m}, f = 50 \text{ Hz}$)

2.3.3 Dependence of the Transmittable Power on the Cross Section

Fig 4 is a tool to estimate the cross section A. An exact determination includes the line length. The graph is based on formula (4):

$$P = DU_n \cdot U_n) / l \cdot f \{4a\}$$

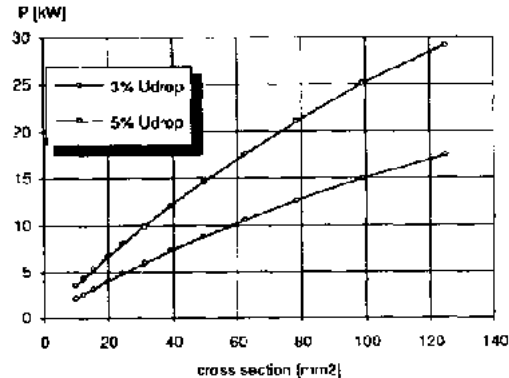

Fig 4 Cross section A as a function of P for 380V and 500m line length

2.3.4 Voltage Drop

The circuit in Fig 3 holds true for balanced 3 phase lines (star connection).

$$\Delta U_n = \frac{P \cdot l \cdot \phi}{U_n} \approx \frac{P \cdot l \cdot \phi}{U_n} [\text{V}] \quad (4)$$

P [kW] assumed max. Power

l [km] line length

U_n [kV] nominal phase voltage

φ [Ω/km] resistance per length

The voltage drop for each phase.

2.3.5 Power Losses

$$\Delta U_n = l \cdot R_L \left[\frac{\Omega}{\text{m}} \right] = \frac{l}{g \cdot A} [\Omega] \quad (5)$$

with

l [km] line length

R_L [Ω/m] resistance per length

g [m/Ωmm²] conductivity

A [mm²] conductor's cross section

For the power losses only the resistive part of the line impedance counts.

$$\Delta P = 3 \cdot R \cdot I^2 \text{ [W]}$$

$$\text{with } I = \frac{P}{\sqrt{3} \cdot U_n \cdot \cos \varphi} \text{ [A]}$$

$$\Delta P = \frac{l}{g \cdot A} \cdot \left[\frac{P}{U_n \cdot \cos \varphi} \right]^2 \text{ [W]}$$

$$\text{or with } P \cdot \frac{R}{U_n} = \Delta U_n \quad (6)$$

$$\Delta P = \frac{l}{\cos^2 \varphi} \cdot \frac{\Delta U_n}{U_n} \cdot P \text{ [W]}$$

The power dissipation DP for a balanced three phase overheadline

2.4 Example: Determine Cross Section

For a 3 phase transmission line between power house and village the conductor's cross section has to be calculated. The line length is 500m the line voltage 380V. The maximum power is 7kW and the voltage drop DU shall not exceed 5% of the nominal voltage U_n . Aluminium/steel ropes are used. They are rack mounted (vertically arranged, spacing 0.25m). The load has a power factor of 0.8.

$$\begin{aligned} \varphi &= \frac{0.05 \cdot U_n \text{ [V]} \cdot U_n \text{ [kV]}}{P \cdot l} \\ &= \frac{0.05 \cdot 380 \text{ [V]} \cdot 0.38 \text{ [kV]}}{7 \text{ [kW]} \cdot 0.5 \text{ [km]}} = 2.06 \left[\frac{\Omega}{\text{km}} \right] \quad (xI) \end{aligned}$$

In order to keep DU below 5% of U_n , has to be less than .

$$\begin{aligned}
 R_L &= \phi - X_L \cdot \tan \varphi \\
 &= 2.06 - 0.3 \cdot 0.75 \left[\frac{\Omega}{\text{km}} \right] = 1.84 \left[\frac{\Omega}{\text{km}} \right] \\
 &= 0.00184 \left[\frac{\Omega}{\text{m}} \right] \\
 A &= \frac{1}{\rho \cdot R_L} = \frac{1}{26 \left[\frac{\text{m}}{\Omega \text{mm}^2} \right] \cdot 0.00184 \left[\frac{\Omega}{\text{m}} \right]} \\
 &= 20.9 \left[\text{mm}^2 \right] \quad (x2)
 \end{aligned}$$

The reactance X_L is approximately (see Table 3) 0.30 [W/km] so with formula 1 and knowing X_L , both R_L , and D can be estimated

The next thicker conductor in Table I is AWG4 ACSR with $A = 24.68 \text{ mm}^2$, $R_L = 1.36 \text{ W/km}$ and $X_L 0.3 \text{ W/km}$.

$$\begin{aligned}
 \Delta U_n &= \frac{P \cdot l \cdot \phi}{U_n} = \frac{7 \text{ [kW]} \cdot 0.5 \text{ [km]} \cdot 1.81 \left[\frac{\Omega}{\text{km}} \right]}{0.38 \text{ [km]}} \\
 &= 16.7 \text{ [V]} (= 4.4\%) \quad (x3)
 \end{aligned}$$

Check voltage drop for the selected conductor (temperature = 60°C).

If ΔU would exceed the tolerance of 5%, the next thicker conductor would have to be selected.

Power Loss

$$\begin{aligned}
 \Delta P &= \frac{l}{g \cdot A} \cdot \left[\frac{P}{U_n \cdot \cos \varphi} \right]^2 \\
 &= \frac{500}{26 \cdot 24.7} \cdot \left[\frac{7}{0.38 \cdot 0.8} \right]^2 \text{ [W]} \\
 &= 413 \text{ [W]} \quad (\approx 6\%) \quad (x4)
 \end{aligned}$$

It is interesting to know the power loss in the line for a plant running 8000 hours a year, the production is 56 MWh and the losses 3.36 MWh. At 10 cents per kWh this might be a financial loss of 336\$ per year!

[Home](#) > [ar.cn.de.en.es.fr.id.it.ph.po.ru.sw](#)

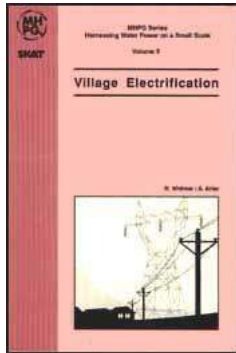

Village Electrification (SKAT, 1992, 128 p.)

Part 7: Commercial engineering

(introduction...)

1. The initial enquiry

2. Terms and conditions for specification, orders and contracts

3. Limits of responsibility

4. Tender mechanism

Village Electrification (SKAT, 1992, 128 p.)

Part 7: Commercial engineering

Enquires, Tendering & Contracts

This part was originally written by the Dept. of Mechanical Engineering, Edingburgh University and then edited by Adam Harvey and Andy Brown for the 'Micro Hydro Power Training Course, Design Guide' for IT (Intermediate Technology) and CEB (Ceylon Electricity Board).

The purchase of equipment and service involves large sums of money and therefore considerable financial risk. The risks are reduced and managed by the "commercial engineering" aspects of the project, which are just as important as its technical and economic co-ordination.

1. The initial enquiry

The purchasing engineer first prepares the initial specification, as shown in table 1.

This is sent to various potential suppliers, with a note attached to say that a more detailed specification will be negotiated later. Each supplier replies by proposing a system and quoting its cost. Following this, it is essential that all technical matters are clarified. A checklist is given in Table 2.

Some of the items on the list are specified by the supplier, and some by the purchaser. If you are the purchasing engineer, you can use this list as a basis for a letter sent to the supplier in response to the supplier's initial quote, inserting the items as questions where appropriate.

When both parties are satisfied with the specification, it can be considered alongside other finalized quotations, perhaps in a formal tendering procedure as described in section 4.

How tight should this detailed specification be? The supplier will prefer it to be quite

general and flexible. This approach leads usually to a greater follow-on cost, because sorting out difficulties with performance and operation becomes very time consuming. If the specification is detailed and the correct paperwork is in order, it is relatively cheap and quick to sort out responsibilities. It is also much easier to monitor the performance of the equipment and evaluate the scheme's viability.

It is not necessary or advisable for the purchasing engineer to attempt to define exactly the equipment supplied by the turbine manufacturer. But it is necessary for the turbine manufacturer to define the equipment in detail in the request of the purchaser, so that the purchaser has a clear and comprehensive specification to refer to.

Note that when specifying an alternator "kVA" is listed as well as "kW". This is because electrical current is a critical design parameter with respect to alternator operation.

In setting specifications, do not underestimate the ability of the seller to identify attractive alternative ways of implementing the scheme. For example, the seller may be able to supply and utilize a reconditioned alternator, with slight modifications to the rest of the scheme. The use of second-hand or available cheaper equipment can significantly improve the return on capital investment. Modifications to a specification in order to accommodate such alternatives can be difficult to assess but may prove worthwhile.

The initial request is made by providing the following information

- 1. Gross head available.**
- 2. Maximum or Design Flow available.**
- 3. Net Head available at design flow.**
- 4. Minimum Power at the shaft or at the alternator terminals under full flow conditions.**

5. Part Flow Efficiency. This can be initially indicated by a single design point. Specify a part flow with corresponding net head and, if necessary, specify a minimum power at this flow. If necessary supply penstock flow & head curves and request turbine performance curves for the complete flow range.

6. Preferred Governor. Specify if a particular method (load or flow control) is preferred or required. Power Demand Characteristic. Describe the loads to be driven and their power factors.

Table I Initial specifications sent to various potential suppliers.

... Items 1-7 in the initial request (table 1) must be included in expanded form.

8. Water Quality Specify whether chemical characteristics of the water are normal or whether it is corrosive.

9. Silt Particle Size Ask the supplier to specify the particle size, which can be accommodated by the turbine and inform the supplier what particle size is achievable by the silt basins.

10. Connection, Water End Specify type and dimensions of joints on penstock end, where the turbine is to be connected.

11 Isolating Valve Clarify whether turbine is fitted with an isolating valve shutting off water supply; type of valve, closing time.

12. Drawings Both schematic sketches and detailed drawings of equipment must be supplied, with dimensions and weights.

13. Drive System Ask supplier:

*** whether drive direct or geared - if geared, provide information on all components, working life, and maintenance procedures;**

*** the characteristics of the bearings supplied with the turbine: whether they are capable of taking side loads (radial loads) and their working life for expected loads and similarly for the alternator if supplied;**

*** which spares are advisable.**

14. Instrumentation Specify a pressure gauge on turbine inlet manifold. If the turbine is the Francis type, request a pressure gauge also on the draught tube. List other instruments required.

15. Spare Parts Request supply of spare parts on short-life components. Examples given here include alternator parts, drive system parts.

16. Tools And Manuals Maintenance procedures must be clearly described in written manuals. Suitable special tools must be provided. One important special tool is a rifling hoist for turbine installation and maintenance.

17. Governor

*** If a governor is supplied, take special care in the case of mechanical governors to procure service support.**

*** If no governor is supplied, it is likely that you are planning to buy an ELC independently. If so send the same alternator specification to both the ELC manufacturer and alternator supplier (or the turbine supplier if this is the source of the alternator as well). Both sources should approve the specification; ask the alternator supplier to check suitability of**

the thyristor load of the ELC, the type of AVR, and so on.

18. Alternator

*** If the turbine manufacturer is supplying the alternator, provide the alternator specification and protection requirements.**

*** If the turbine manufacturer is not supplying the alternator, specify the radial load on turbine shaft. Request drawings showing positions of turbine bearings, position of pulley mount.**

19. Draught Tube If a reaction turbine is to be supplied, specify suction head for "draught" required.

Request range of suction heads allowed for efficient turbine performance, and power output curves for this range. This allows planning of civil works in the installation of the turbine.

Table 2 Detailed technical specifications.

Our reference: MH003

GENERAL SUPPLIES LTD

For the attention of the Sales Department

We would be pleased if you would tender us for the generator detailed below by Friday 28th February 1999.

Type of turbine Pelton wheel

Drive system belt drive

# of units	one
Turbine input power	35 kW
Generator rating	50 kVA
Duty	Maximum continuous rated
Speed	500rev/min
Overspeed	180% continuously
Voltage, phases	415V, 3-phase
Frequency	50Hz
Power factor	0.8 lagging
Mounting	Vertical shaft, skirt mounted
Type	Salient pole, synchronous "
Bearings	Grease lubricated, suitable for radial thrust of 400kg continuously
Excitation	Shunt with forcing current transformers (CTs)
AVR	Mounted internally, voltage regulation = +-2.5% with under/over-voltage and under -lover-frequency protection
Electronic switching	ELC; thyristor action; how many switches/secs?
Ambient temperature	40°C
Altitude	500 metres asl
Humidity	90%
Loading	Electronic load control (thyristor load)

The generator should be designed and rated in accordance with BS4999/BS5000, or equivalent, and should be provided with a class F insulation system. Please advise the weight of your proposed generator, and provide an outline drawing with your tender. The following accessories should be included in the price of the generator: slide rails, holding down bolts. Spares should include rectifier sets, diodes, bearings and AVR. Please show additional prices for: anti-condensation heaters; winding temperature detectors; tropical paint finish; shaft-mounted speed switch.

Your tender should be submitted subject to the following commercial conditions.

CONDITIONS OF SALE: Your tender should be based on 1 Mech E/IKE Model form B2 conditions of contract.

PRICES: Your prices should be firm and fixed for the validity period stated and include works testing, packing for shipment, and delivery CIF Colombo.

Your prices should be quoted in US\$ or UK£.

VALIDITY: 120 days from the date of tender.

DELIVERY: Your delivery time CIF Colombo should be quoted from receipt of order.

Our estimated delivery time is 15 weeks.

TERMS OF PAYMENT: 100% of contract value on delivery CIF Colombo.

PENALTY CLAUSE: A penalty would apply at a rate of 0.5% of the contract value per week of delay up to a maximum of 5.0% of the contract value. Please do not hesitate to contact us if you require any further assistance.

CUSTOMS & IMPORT DUTIES: All duties and taxes to be paid by the supplier.

GUARANTEE: All items to be covered by a two-year guarantee to include parts and labour; the guarantee to operate from the date of delivery.

DOCUMENTATION: Supply to include full installation, operation end maintenance manual in triplicate and in English language.

Yours faithfully Purchasing manager

Table 3 Request for tendering for an electrical generator - an example

2. Terms and conditions for specification, orders and contracts

2.1 Standard Conditions of Sale

Standard conditions of sale, correctly defined and applied, are an effective safeguard against the commercial problems which may occur in a project involving the purchase of engineering equipment. Both the purchaser and the seller should understand, accept and agree to work with the same set of "rules" controlling the contract. In case the purchaser and the seller disagree on a commercial or technical matter, affecting the commercial conditions, they must follow the instructions in the conditions of contract, and may finally have to accept the decision of an external arbitrator nominated in the conditions of contract.

Typical UK conditions of contract that are often applied and accepted throughout the world are listed below:

BEAMA "AK" Conditions of Sale - for the sale of individual items of electrical and in some cases mechanical equipment, exclusive of full delivery to site, or erection. These are published by The British Electrical and Allied Manufacturers Association, of 8 Leicester Street, Leicester Square, London.

IMech. E/IKE Conditions of Contract model form: B1 - for the supply of electromechanical plant

(excluding delivery to site, or erection)

B2 - for the supply of electromechanical plant (excluding delivery to site, but with supervision of erection)

B3 - for the supply of electromechanical plant (excluding delivery to site, but including erection of equipment at site)

These are widely accepted and govern the supply and delivery FOB, but not delivery to site, of equipment. The choice of these is based on the extent of the seller's involvement at site.

Many major sellers seek to apply their own conditions of contract, which puts the responsibility for accepting these conditions on the purchaser. The disadvantage to the purchaser is that the conditions will almost certainly favour the seller, but the advantage is that the price should be slightly lower as the seller should accept his own conditions.

It is best for the purchaser to apply the same commercial conditions to all sellers, as this reduces the variety of contract management required. This may have the effect of increasing the prices slightly as sellers may have to accept commercial conditions they might consider unfavourable to them. There is a balance to be made between commercial rigidity and obtaining minimal prices.

There are many other acceptable conditions of contract, operated by EC, North American, Australian and Asian sellers. A good standard they might be compared with is the equivalent UK set of conditions.

2.2 Limits to the Scope of Supply

To avoid any errors and, even more important, the omission of any item of equipment, it is important to state the limits of the scope of supply of equipment at the beginning. Enquiry documents should state in words (and on drawings if possible) a precise list and brief description of every major item of plant that is to be included in the contract. Where an auxiliary plant is required to be an item of the plant work, it should be stated that the auxiliary plant is also to be provided. A good way of defining the limits of supply is to describe all of the interface points for each major item of plant.

Example: Generator Coupling to water turbine Main terminal box Auxiliary terminal box Mounting feet and bolts

Having detailed the full scope of supply the job of tendering is easier as the seller can decide easily which equipment he has to include. Also, the purchaser can more easily decide whether or not a tender is the same as the enquiry document.

2.3 Prices

Where estimates of prices are required for budgeting purposes, a purchaser may request budget prices from sellers. This type of price is not contractual and is usually accurate within 10% of the actual price of the equipment.

Where a purchaser asks for prices against which to place an order, these are said to be firm prices. These prices are contractually binding if the offer is accepted and would not change unless there are contract variations which are dealt within the conditions of contract.

Firm prices can be given in two different ways: as fixed or with Contract Price Adjustment (CPA). A fixed price is one which does not vary at any time, for example due to the effects

of inflation during the period of the contract.

Example: Fixed price

Tender Price: \$1000 on 1st January Order Date: 1st April

Despatch Date: 1st July

Inflation: 5% from 1st Jan to 1st July

Payment: \$1000

CPA (Contract Price Adjustment) takes into account any increases (or decreases) in the costs for the seller (for example materials and labour). A CPA price is declared at the time of tender and given a reference date. The amount paid for the plant is changed by a formula which has a material, a labor and a fixed element. It is important to agree at the enquiry stage on both, the formula and the indices to be used for materials and labor.

Example: CPA price

Tender Price: \$1000 on 1st January

Order Date: 1st April

Dispatch Date: 1st July

Assumed Rise: 5% from 1st Jan to 1st July

Payment: \$1050

2.4 Validity

The validity of a tender is the period of time in which the purchaser can place the order with the seller. The validity may be defined as a number of days/months from the issue date of the tender or from another specific date. Once a tender has passed its validity (expiry) date, it is no longer contractually binding for the seller and any extension in the validity period may increase the prices.

When specifying a validity period, the purchaser should indicate a sufficient time required

for checking the received tenders and placing the order.

2.5 Despatch, Delivery and Completion Times

Aspects such as the weather, availability of transport or labour may dictate the programme dates. If you are a purchaser with a specific construction programme, you may wish to indicate in the enquiry the despatch, delivery and completion dates which have to be observed. Where possible, plant despatch periods should be estimated in advance through discussion with the sellers.

Important dates, such as despatch or completion, may be subject to financial penalty if they are not met by the seller. Seeking to impose large penalties for failure to meet these dates may result in fewer tenders being submitted and higher prices from those who do tender.

Estimated despatch and completion dates should always be stated in tenders.

The tender document can encourage better planning by requesting detailed bar charts to show activities and time scales. The tender document should also ask for supervision to be budgeted for in detail.

2.6 Penalties

A penalty clause in a contract is a specific attempt to persuade the seller to complete the contract satisfactorily. Failure to do so would result in the seller paying a specific sum to the purchaser. This sum may not be related to the contract value and may not be in proportion to the actual loss suffered by the purchaser. Note that the seller would receive full payment for the contract.

It is vital to include realistic penalty clauses. Penalty clauses are typically based on

potentially lost earnings. A final date should be set for when penalty payments are no longer acceptable and the seller loses the contract. In practice it is very inconvenient to terminate a contract at an intermediate stage as the purchaser would have difficulty in finding someone prepared to finish the job within the required time.

An exception clause should be included for events out of control of seller and purchaser, such as natural desalters, civil unrest or changes in the political setup.

2.7 Contingency

Where the purchaser is bound by complex rules on payments e.g. government body, it is often convenient to include a contingency (say 10%) to cover unforeseen costs. These save expensive delays by allowing the seller to file small claims without lengthy procedures.

2.8 Terms of Payment

The terms of payment decide the dates on which the seller will receive payment. The dates chosen for progress payments usually relate to specific events during or on completion of manufacture. Purchasers should remember that sellers have to buy materials before assembly and, in the case of a small firm, may require part payment either on order or shortly afterwards to finance their purchases.

Care should be taken not to overpay since the contractor loses the incentive to complete. It is necessary to hold back about 10% of the contract value for at least a period of three months after the completion of the work. This gives the purchaser some hold on the seller for unfinished work.

Payments for stock items or low-cost items are usually made 100% on despatch or delivery.

The conditions of contract will make allowances for variations to the payment dates due to delays in the running of the contract.

2.9 Letters of Credit

The purchaser may often find that overseas sellers require that payments are made against Confirmed Irrevocable Letters of Credit. Compliance with this would require the purchaser to instruct his or her bank to issue a credit in favour of the seller; this in turn is confirmed by a bank in the country of the seller. The effect of this is to provide security to the seller that payment will be made and failure to provide a letter of credit may result in the seller withdrawing from the contract. Provision for the costs associated with this should be made by the purchaser and, when implementing a Letter of Credit, the expiry date should make allowance for the issue and transfer of documentation, otherwise the credit may expire before the goods are shipped.

2.10 Currency and Exchange Rates

Sellers, particularly small firms, will prefer to tender in, and receive payment in their own currency. Whenever possible, the purchaser should attempt to make payments in that currency. If this proves difficult, some sellers may accept payment in a currency of a third country, provided that it is a "strong" currency, such as US dollars.

2.11 Taxation

Purchasers should investigate and make allowance for all local taxes which will arise from the installation. Any such taxes which will apply to the seller (and personnel during erection/commissioning) should be made known at the enquiry stage.

Sellers should take account of any taxes for which they are liable in their own country. Any taxes or duties arising through the export of the plant should be identified and the

purchaser should be made aware of the resultant additional costs.

2.12 Customs and Import Duties

Where these are applicable, the method of payment and whether they are to be paid by the purchaser or the seller should be stated at the enquiry stage. A seller who is to be responsible for these, may overestimate them at the tender stage thus increasing these and may as well pay the precise sum known at the time of shipping rather than an estimate, which will possibly be high.

The seller must make an effort to establish in advance the cost of customs and import duties.

2.13 Guarantees

As a minimum, the purchaser should obtain from the seller a 12 months guarantee period covering the satisfactory operation of the plant supplied.

Of particular importance is the information given by the purchaser to the seller at the enquiry stage. Equipment can only be designed and manufactured on the basis of the data given at this stage, and it will be on this information that the guarantee will be based. In the event that the equipment is operated under different conditions to that for which it was designed, the guarantee will not be valid. Similar constraints will be placed on the maintenance of the plant to keep the guarantee valid.

Another important point to cover in the pre-contract correspondence is the date from which the guarantee operates; for example, from date of manufacture, date of dispatch or date of completion of erection. Most sellers will limit the final date of expiry in relation to the manufacture date in case there are delays in shipping and installation which are beyond their control.

Equipment is normally guaranteed for a period of 12 months from commissioning but no longer than a period of 18 months from the completion of manufacture.

2.14 Documentation

Most sellers will issue a limited number of copies of arrangement drawings and Operation and Maintenance Manuals. Any particular requirements which the purchaser has in respect to documentation should be made clear in the enquiry document. Requests for large amounts of documentation will probably lead to higher tendered prices and may result in a delay in the completion of the contract.

2.16 Spares

Very often, the raising of money to purchase equipment is a difficult task. It is thus important to make provision for spares to cover commissioning and the first few years of operational life of the plant in the original order. The purchaser may ask the seller to provide the recommended spares for say, two years' operation. If possible, the purchaser should investigate the experiences of similar installations in the region and draw up detailed list of the components which are likely to require replacement.

2.17 Training

The provision of spares cannot guarantee to cover every possible fault which may occur. In order to run the equipment satisfactorily the be trained to operate and maintain the equipment in accordance with the seller's instructions. The operation within the design rating of the plant along with regular routine maintenance should increase the lifetime of the equipment.

The most suitable time for training is usually during or just after commissioning the plant by the seller's skilled engineers. If training is required as a part of the contract, then this

should be indicated in the enquiry document.

3. Limits of responsibility

The completion of a contract is said to be the point where the seller is no longer responsible for the equipment which has been supplied other than under the terms of the guarantee. At this time the purchaser thus directly assumes full responsibility for the equipment.

The most common limits of responsibility are as listed below.

3.1 Ex-Works

"Ex-works" means that the seller's' only responsibility is to make the goods available at their premises (i.e. works at factory). The purchaser bears the full cost and risk involved in bringing the goods from here to the desired destination. This term thus represents the minimum obligation for the seller.

3.2 FOB

FOB means "free on board". The goods are placed by the seller, free of cost to the purchaser, on board a ship at a port of shipment named in the sales contract.

3.3 FOR

FOR and FOT means "free on rail" and "free on truck". These terms are synonymous since the word truck relates to the railway wagons. They should only be used when the goods are to be transported by rail.

3.4 C&F

C&F means "cost and freight". The seller must pay the costs and freight necessary to bring the goods to the named destination.

3.5 CIF

CIF means "cost, insurance and freight". This term is basically the same as C&F but with the addition that the seller has to produce insurance against the risk of loss or damage to the goods during carriage. The seller contracts with the insurer and pays the insurance premiums.

3.6 C&F to Site

While C&F is used for goods which are to be carried by sea, the term "freight or carriage paid to. . ." is used for land transport only, including national and international transport by road, rail and inland waterways. The above limits are indicated in Fig 1.

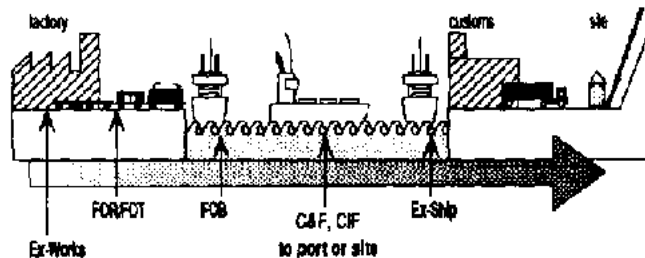

Fig 1 Limits of responsibility

Purchasers must take responsibility for the equipment beyond the limit provided for by the seller and must make provision for the completion of the transport of the equipment to the site. In general, the purchaser will know the transport conditions, route and haulage contractor better than an overseas seller, thus the costs of transport within the

purchaser's country will probably be lower if arranged by the purchaser rather than the seller.

The purchaser must also decide how the equipment is to be erected and commissioned once it arrives at site. This will depend on the level of skills of the purchaser's own staff and of the skill and availability of local skilled personnel. If there is a requirement for skilled erection and commissioning engineers from the seller, this should be decided early in the contract period. Normally, sellers can provide erection and commissioning engineers who will supervise labor provided by the purchaser. Alternatively, there may be a local firm with the necessary skills that would be able to perform the installation in accordance with the seller's drawings and manuals.

4. Tender mechanism

The purchaser must include those items considered important in the previous sections into an enquiry document, which supplements the schedule of equipment and specifications of equipment required for the project. The letter sent with the enquiry, and the enquiry document, should state the correct receiving address for tenders, and the closing date by which tenders are to be received (beyond the closing date, the purchaser has the right to return tenders to the sellers unopened and without consideration). The enquiry should then be sent to as many sellers of equipment as possible (see example in table 3).

It is a good idea to ask sellers to confirm receipt of the enquiry, and their intention to submit their offer by the specified closing date.



During the tendering period it is possible that there will be sellers who will require clarification of the specification or commercial conditions, and who will contact the purchaser to obtain this information. Such questions should be treated professionally and confidentially. There will always be sellers who wish to tender standard equipment, which may not exactly meet the specification. Provided they are prepared to state in their tender

where they do not comply with the specification, and that there is commercial or technical advantage in offering other equipment, there is no reason why a seller should be prevented from doing this. Such deviations should be treated confidentially, as they may represent a commercial advantage to both the seller and the purchaser. It is good practice to state in the enquiry and afterwards to assume that "unless clearly stated by the tenderer, the offer will be deemed to be technically and commercially compliant with the specifications and commercial conditions in the enquiry document ". On receipt of all tenders for equipment, the offers must be assessed for technical and commercial compliance. A quick check will establish an order of merit from the most to the least expensive. Those which are clearly too expensive may be set aside at an early stage, provided that this leaves enough cheaper bids from otherwise respectable companies. It is crucial that all of these exchanges of information be kept confidential, in telex or written form. Different sellers should not be able to gain access to detailed information from other tenders. Otherwise, they are able to lower the prices on offer and they will in the longer term simply discourage companies from tendering. There is no harm in going back to all sellers, or those whose bids are otherwise attractive and seeking reductions in price, if it assists the project to proceed. Subject to money being available, the purchaser is then in a position to place an order for the equipment.



[Home](#) > [ar](#) [cn](#) [de](#) [en](#) [es](#) [fr](#) [id](#) [it](#) [ph](#) [po](#) [ru](#) [sw](#)

 **Village Electrification (SKAT, 1992, 128 p.)**

  **Part 8: Tariffs & financial evaluation**

 *(introduction...)*

 **1. Determine tariffs**



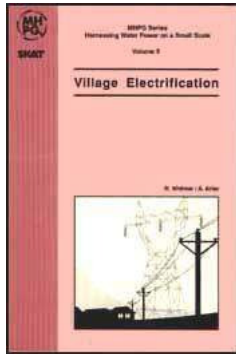

3: Example

Village Electrification (SKAT, 1992, 128 p.)

Part 8: Tariffs & financial evaluation

Tariffs are a crucial point in any electrification scheme. Often they are economically not viable and lead to the project's failure. Pricing is on one hand pure economy on the other pure politics and they often counteract. Is for instance a national grid close by, it will be very difficult to have another pricing than 'they' have, unless you are cheaper. Very often the national supply is highly subsidized and economically hard to beat.

The lever to really get low prices is the load factor: the closer generation reaches 100% of the rated energy production, the more competitive your tariffs are. Besides rising the load factor from let's say 40% to 80% almost nothing else counts. But also this is true; the load factor is a vicious circle. If it decreases, your prices will rise, you will lose customers, lose more load ... many MHP electrification projects vanished through this mechanism.

It is difficult to give comprehensive strategies for a successful pricing but we present some methods and calculations to estimate tariffs and some criterias to establish a tariff

structure.**1. Determine tariffs**

A traditional approach would start with a stocktaking and evaluation of all assets from which, after applying certain depreciation rules, the annual capacity related or kilowatt-related costs are derived. Then there is an evaluation of the various running costs, like fuel, which leads to the energy-related or kilowatt-hour-related costs. For an electrification based on renewable energies like MHP, this heading might become almost negligible. Some costs, like maintenance, have both fixed and variable components and are allocated accordingly. Finally there are some costs, like meter reading, which are consumer-related and not related with either capacity or energy demands.

All these costs have now to be charged to the consumers as fairly as possible through an appropriate tariff structure. With some research in the consumer demand pattern (load research), the supplier is able to identify each consumer class' contribution to the peak consumption, thus, to the capacity-related costs. To these the energy- and customer-related costs are added and a 'cost-based' tariff is formulated for each consumer class.

On a typical bill therefore several elements may appear: for instance a fixed or minimum charge to cover customer costs; a kilowatt charge to reeover the capacity costs and, of course, a kilowatt hour charge.

Often some simplification is needed. For instance metering might be too expensive, at least for some consumer classes. In this case, a fixed maximum power distribution (through current limitation with a fuse (see part 11: The Salleri Chialsa Venture) might be used, to determine an average energy consumption and define a consumer class. This allows for instance to drop kilowatt-hour-charges altogether and include kW-charges (as they are fixed) into the fixed charges. The consumers' monthly bill would include only one constant figure.

This traditional approach, as simple as it is, has its drawbacks:

- **It is backward-looking, adjusting tariffs based on 'old' data. But to steer the consumption would need a forward-looking approach.**
- **It generates tariffs based on averages rather than marginal costs.**

Simplifying bills, as discussed before, 'blinds' the consumer. He can't influence the bill directly with his consumption behavior. Especially when peak energy is scarce, one would like to steer the customers behaviour, so they divert some consumption to the off-peak hours (or even off-peak season). It needs the application of different tariffs during day (or season), inviting consumers to benefit from cheaper energy during off-peak. Unfortunately this involves costly (time) meters. This also shows a general relation: to keep the customer informed about the energy costs and influence his consumption pattern, you need to know the details about the consumption of individuals which inevitably involves additional costs.

2. Financial evaluation

To determine the tariffs, partly the same calculation tools can be applied as for the financial analysis of investments. Therefore a very brief introduction to those methods might be helpful. The following is a rather mathematical collection of evaluation methods presented in 'A Guide to the Financial Evaluation of Investment Projects in Energy Supply' (see references). Additional reading could be necessary. In the example presented at the end of this part only annual costs are of interest, so only formulae {6}, {10} and {16b} are actually used. You may skip the rest.

2.1 Interest and Inflation Rates

Depending on the kind of financing an appropriate interest rate has to be chosen:

- **For external financing of the investment costs it should be fixed at an effective rate of interest for debt during an equal loan period.**
- **For internal financing of the investment costs it should be fixed at an effective rate of interest on capital deposits during an equal period.**
- **For mixed financing a weighted mean value can be used as interest rate.**

In case of high price stability a constant interest rate i can be assumed and the market interest rate p is used for calculations. For many countries, however, high inflation rates must be included to ensure accurate calculations. In this case an actual interest rate i^* is used. It can be determined as follows:

with inflation rate a (inflation factor $e = 1+a$) and market interest rate p (market interest factor $r = 1 + p$) and actual interest rate i^* (actual interest factor $q = 1+i^*$) and

$$q = r/e \{1\}$$

we get

$$i^* = \frac{1+p}{1+a} - 1 = \frac{p-a}{1+a}$$

example: with $p = 32\%$ and $a = 22\%$

$$i^* = \frac{0.32 - 0.22}{1 + 0.22} = 0.082 = 8.2\%$$

{2}

Especially for projects in energy supply it might be necessary to assume different inflation rates. Prices for fuel for instance may vary more than the rest.

2.2 Investment Costs

To calculate the economics of an electrification and establish tariffs, the used and required investment is an important factor. It is necessary to collect and quantify all cost components, indexed according to their time of occurrence. The following table (see Table 1) could be used for that. It is necessary to predict the service life of such an installation as accurately as possible, both to determine the depreciation and the residual value.

investment costs	period	0	1	2	3	...
Planning						
land acquisition						
civil works						
buildings and structures						
connection to infrastructure (road...)						
machinery & equipment (ex-works):						
- power plant						
- main distribution						
- consumer connection						
- workshop equipment						
transport & insurances						
assembly & commissioning						
customs, taxes, duties, fees...						
contingencies						
TOTAL of investment costs						

Table 1 Investments stocktaking along the project's life span.

The first decreases with the service (depreciation) life time, the latter with residual value = investment(1-servicelife/techn life) {3}

is zero if service and technical life are equal and increases if the plant or parts are able to operate longer than the service life time. Often in a power plant, technical life spans of

machinery and buildings are very different and residual values (book value) might be high for premises and zero for the equipment.

2.3 Operating or Running Costs

This term includes all foreseeable costs to operate the project. It does not include investment costs like capital interest and depreciation. Following a list of possible operating costs:

manpower costs Administrative and operating staff may form a considerable part of the total operating costs. They must be estimated carefully and exactly, including number, qualifications and employment periods of required staff and market usual wages, salaries, associated (social security contributions...) and any other standard (holiday pay, bonuses...) personnel costs. Inflation has to be taken into account!

repair & maintenance costs This term is very difficult to estimate accurately and one has normally to rely on manufacturers' information about their experiences. These estimates, however, tend to be optimistic and it is advisable to adjust them upwards.

energy related costs They are nil for renewable energies like solar, wind, hydro and thermal energy.

auxiliary material costs They include lubricants (grease, oil...) etc. and could be included under maintenance.

administration costs (excluding manpower) This includes office rents and supplies, communications etc.

taxes and duties They may be imposed on water utilisation, energy generation, land property etc. and have to be according to local tax laws and duty regulations. other costs

Whatever cannot be included above.

2.4 Income

Income is generated by: a) revenues from energy sales b) savings on commercial energy c) increased/ improved production of goods Fairly simple to estimate is case b). a) and c) might be extremely difficult, but very important to know the plant's profitability. Imperative is an investigation on the power demand = > see example at the end of this chapter. d) Services: Connection fees, electrical installations, selling of electrical appliances and consultancies could be services offered to the consumers and charged individually. Basic services like the consumers' connection to the distribution line, might partly be paid by increased kWh charges. e) Subsidies: They are often the only way to have an electrification scheme started. Governments or foreign donors may grant substantial amounts to electrification programs. However, subsidies always distort the real generation costs. It has to be carefully considered which costs of the program should be subsidised. In the long run subsidies should be avoided!

2.5 Returns & Profit

**The annual returns are the difference of the total incomes and the total operating costs.
return = total income - operating costs**

The profit is the return minus the depreciation (the periodic reduction in the value of the plant and grid).

The depreciation does not influence the periodic returns but the periodic profit! profit = income- operating costs- investment costs

2.6 Static Procedures for Financial Evaluations

2.6.1 Basic Cost Comparison Calculation

We include in the total costs two major headings: the operating costs OC (for which we will use an annual average $\langle OC \rangle$ in the beginning) and the invested capital costs which have two components, a depreciation and a (compound) interest part. To start with we will simplify the capital costs with:

I_0/T linear depreciation

$(I_0/2) \cdot i^*$ interest {4}

linear depreciation: amortisation of the bound capital per time period in equal chunks. T is the number of periods.

Interest: interest payments per time period at an actual interest rate i^* , which is applied to the average bound capital (initially invested) for the duration of the project. In the beginning the bound capital is I_0 , at the end 0, so we get the average $(I_0-0)/2$.

$$C_T = (OQ + I_0/T + I_0/2 \cdot i^*)$$

C_T total costs per time period (including depreciation and interest)

$\langle OC \rangle$ average operating costs per time period

I_0 initial investment costs

i^* actual (assumed) interest rate {5}

If the plant and distribution system are not completely written off at the end of the service life (residual value > 0), a positive liquidation yield L has to be deducted from the

investment costs and CT is recalculated as follows: (with $\langle I \rangle$ = average invested capital per time period)

$$\langle I \rangle = (I_0 - L)/2 + L = (I_0 + L)/2$$

$$C_T = \langle OC \rangle + (I_0 - L)/T + (I_0 - L)/2 \cdot i^* + L \cdot i^* = \langle OC \rangle + (I_0 - L)/T + \langle I \rangle \cdot i^*$$

In the last term we have to consider the interest of the tight-up capital L , which adds a constant interest.

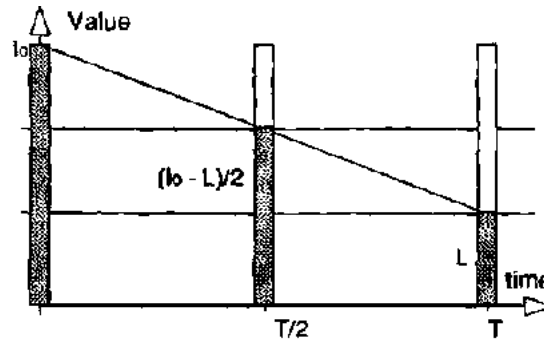

Fig 1 Depreciation of an initial investment.

2.6.2 Static Cost Annuity Comparison

(annuities = equal annual payments) Before we present this method, we will introduce two important factors, the Present Value factor $PV(q,t)$:

$$PV(q,t) = \sum_{r=0}^{t-1} q^{-r} = (q^t - 1)/q^t(q - 1) = (1 - q^t)/(q - 1) \quad \{7\}$$

The present value factor is a function of time and interest rate; it takes compound interest into account. Multiplied with the periodical, constant payment, it gives the present value of the total investment. If we need to know the present value of some value in the future (for instance the liquidation yield L in T periods), we simply skip the summation E

and get $PV(q, T) = q^{-t} \cdot b$

example: a monthly payment of \$200 terminates after 7 years. What is a) the present value of this investment if the interest rate is 8%? And what is b) the present value of a liquidation yield of \$5'000 (value in 7 years from now)? $q = 1 + 0.08/12 = 1.00667$ (interest per month!) $t = 7 \cdot 12 = 84$ (number of payments) $PV(1.00667, 84) = 64.159$ (use formula $\{7\}$) $q^{-T} = 1.08^{-7} = 0.583$ (hr L)

a) PV of investment = $\$200 \cdot 64.159 = \$12'832$

b) PV of liquidation yield = $\$5'000 \cdot 0.583 = \$2'917$.

and the Recovery factor $R(q,t)$:

$$R(q,t) = 1/(P \cdot V(q,t)) = (q^t \cdot (q-1))/(q^t - 1)$$

The recovery factor is a function of time and interest rate and is the inverse of the present value factor; it takes compound interest into account. Multiplied by the present value of an investment, it gives the periodical, constant payment to recover this investment (depreciation and interest). exemple: an initial investment of \$15'000 must be recovered after 7 years. What is the constant, monthly payment, if the interest rate is 8%? $q = 1 + 0.08/12 = 1.00667$, $t = 7 \cdot 12 = 84$,

$R = 0.0156$ $PV(1.0067,84) 64.159$

monthly payment = $\$15'000 \cdot 0.0156 = \234

Now the static cost annuity comparison method. The difference to the method above is the inclusion of compound interest on the investment (exact calculation) instead of using a simple average.

$$C_a = C_0 + (I_0 - L) \cdot R(q, t) + L \cdot i^* \quad \{10\}$$

C_a total annual Costs

example: (see also example at the end of this pad)

<OC> = \$6'500 (for 1-25 years of operation)

$I_0 = \$70'000$ (initial investment)

$L = 10'000$ (yield after 25 years)

$I^* = 8\%$ (actual interest rate)

$R(1.08, 25) = 0.0937$ (use formula {9})

$C_a = \$6'500 + (\$70'000) \cdot 0.0937 + \$10'000 \cdot 0.08 = \$12'921$

2.6.3 Static Pay-Back Period

It is used to determine the time when the invested capital is paid back. There are two methods: a) cumulative method find k so that

$$-I_0 + \text{return}_1 + \text{return}_2 + \dots + \text{return}_k \geq 0 \quad \{11a\}$$

b) averaging method $\text{cpttal invested } k = \text{annual return}$

$$k = \text{capital_invested} / \text{anual_return}$$

example:

$$k = 70000 / (12100 - 5600) = 11 \text{ years}$$

2.6.4 Calculation of Profitability

If an investment produces a profit, the ratio of this profit and the average capital invested measures the profitability. This ratio is expressed in % and called the Return On Investment (ROI).

$$\text{ROI} = (\text{NPT} / \text{I}) [\% \text{ per time period}] \{12\}$$

NPT net profit per time period

$$\text{ROI} = 8000 / 40000 = 20\% \text{ per year}$$

Including a net profit can be seen as an increase in the annual costs and needs more income.

This calculation can also be used to select the most attractive between two (or more) options.

2.7 Dynamic Procedures for Financial Evaluations

Hereunder we repeat more or less the calculations made before with the difference that future values (running costs, investments...) are reduced to present values.

2.7.1 Net Present Value (NPV)

$$NPV = (R_0 - I_0) \cdot q^{-0} + (R_1 - I_1) \cdot q^{-1} + \dots \\ \dots + (R_T - I_T) \cdot q^{-T} + L \cdot q^{-T} \quad \{13\}$$

and with net cash flow at time t

$$NCF_t = (R_t - I_t) \cdot q^{-t}$$

$$a) NPV = \sum_{t=0}^T NCF_t + L \cdot q^{-T} \quad \{13a\}$$

This method gives the exact present value of all cash flows and the liquidation yield. For each period it considers the net cash flow, which is the return R minus the investment I in this period. It includes investment costs (depreciation & interest)

$$b) NPV = -I_0 + \left(\sum_{t=0}^T R_t \cdot q^{-t} \right) + L \cdot q^{-T} \quad \{13b\}$$

and if all returns are equal R, this simplifies again to

$$c) NPV = -I_0 + R \cdot PV(q, T) + L \cdot q^{-T} \quad \{13c\}$$

If all investments are done at the beginning, this is simplified to ...

2.7.2 Internal Rate of Return (IRR)

Determine the interest rate (IRR) at which NPV = 0. It must then be IRR > i. This is in any case a complicated calculation and has to be solved with a programmable calculator or computer.

$$NPV = 0 = -I_0 + \left(\sum_{t=0}^T R_t \cdot x^{-t} \right) + L \cdot x^{-T} \quad \{14b\}$$

or formula {13c})

$$NPV = 0 = -I_0 + R \cdot PV(x, T) + L \cdot x^{-T} \quad \{14c\}$$

For instance with $x = 1 + \text{IRR}$ and using formula {13b}

To find the solution for {14c} for instance is to find x by searching the roots of this equation (Newton algorithm...).

$$- I_0 + R \cdot \left(\frac{1 - x^{-T}}{x - 1} \right) + L \cdot x^{-T}$$

2.7.3. Annuity Method

It converts the net present value of the project into annual payments of equal amounts.

$$A = NPV \cdot R(q, T) \quad \{15A\}$$

A = annual payments; it must be $A > 0$

$$A_I = I_0 \cdot R(q, T)$$

$$A_R = \left(\sum_{t=0}^T R_t \cdot q^{-t} \right) \cdot R(q, T)$$

($A_R = R$ if annual return R is constant) (15b)

$$A_L = L \cdot q^{-T} \cdot R(q, T)$$

$$\Rightarrow A = A_R + A_L - A_I$$

A_I = annuity of investment costs

A_R = annuity of return

A_L = annuity of liquidation yield

example: $T = 25$ years, $I_0 = \$70'000$
 $R = \$11'000$ (constant), $L = \$10'000$, $i^* = 8\%$.
 $\rightarrow R(q, T) = 0.0937$
 $\rightarrow q^{-T} = 0.146$

$$A = 11'000 + 137 \cdot 6'558 = 4'579 > 0$$

without knowing NPV, A can be found by stepwise calculating (for b)

2.7.4 Dynamic Cost Annuity Comparison

$$a) C_a = \left(\left(\sum_{t=0}^T R_t \cdot q^{-t} \right) + (I_0 - L) + L \cdot q^{-T} \right) \cdot R(q, T)$$

$$b) C_a = \left(\left(\sum_{t=0}^T (R_t - I_t) \cdot q^{-t} \right) + L \cdot q^{-T} \right) \cdot R(q, T) \quad [16]$$

$$C_a = NPV \cdot R(q, T)$$

This is similar to the above method, but instead of using the net cash flows, it works only with the expenses (no income). It is necessary to replace in the static method the constant, average operating costs by its dynamic counterpart:

The liquidation yield is also adjusted and is the same as AL before.

In {1 6a}the annual costs are based on only an initial investment I_0 , otherwise they would have to be adjusted to the second equation {16b}.

2.7.5 Dynamic Pay-Back Period

It is the static method but the returns of each period have to be taken as present values (dynamic). Therefore the dynamic payback period is longer than the static one because here not only the invested capital has to be recovered but also the interests on it. find k so that:

$$- I_0 + \text{return}_1 \cdot q^{-1} + \dots + \text{return}_k \cdot q^{-k} > = 0 \quad \{17\}$$

3. Example

This example shall explain how to determine tariffs and where to use the preceding formulas. It is based on the small grid already described in the chapter 'power factor correction'. There are three consumer groups, the households, the mill and the workshop. We try to follow step by step different strategies to determine tariffs for these groups.

First we establish the load curve during one day (24 hours). Table 3 and Figure 2 (see at the end of this part) show the result. It is assumed that this load curve is valid throughout the year, but mill and workshop run only 80% of the year. In this way we find the total daily and yearly energy consumption, shown in Table 3a.

[kWh/day]	use	[kWh/yea ^r]	
191	100%	69'715	houses
169	80%	49'406	mill
148	80%	43'128	workshop
508		162'250	total

Table 3a Example: the daily and annual energy consumption

This value (together with others like investment, service life etc.) is included in the key data of this electrification, shown in Table 4.

initial investment	0 [\$]	70'000
service life	T [yr]	25
actual interest rate	r [%]	8%
actual interest factor	q [1]	1.08
Liquidation yield	L [%]	10'000
average Running Costs	<RC> [\$]	6'500
Installed Power (consumer)	P_{inst} [kW]	51
Produced Energy	E_p [kWh]	178'000
Consumed Energy (sold)	E_c [kWh]	162'250
Energy losses & internal	E_l [kWh]	15'750

Table 4 Example: electrical and financial key data for this electrification scheme.

Table 5 shows the results of three different cost calculation methods, all described above: basic cost calculation, static and dynamic cost annuity comparison. The annual costs are different as each method handles the depreciation and interest payment differently. As none of this calculation includes profit, the results are just covering the expenses. The costs (and so the tariffs) could be increased by some % to have a certain buffer for contingencies.

The following calculations work with the concept of keys to distribute the annual costs among the consumers. It ensures that the revenues recover the annual costs. We will use two different keys: one to set the distribution of the annual costs among the consumer groups (-> key 1) and the other to set the distribution for the consumers' bill headings (-> key 2).

Table 6 proposes four alternatives for key 1 (a-d). The legend describes their definition and use. Any other key I could be defined and used!

Table 7 displays four alternatives (variant 14) to determine each connection's electricity bill (key 2). Basically three headings are assumed: a fixed charge, a kW charge and a kWh charge, but these are not always used in order to simplify the billing procedure.

The calculation is rather simple once the keys are set: An 'exclusive' price, which is the price each connection would have to pay, if its group would be alone (no other consumer groups on the grid), is calculated. The total on the bill is found by multiplying this 'exclusive' amount with key 1 and key 2 (and to sum the results if more than one bill heading is used).

Cost Calculation Method 1				remarks
average invested capital	ci	[\$/yr]	40'000	
Total Annual Costs 1	C1	[\$/yr]	12'100	formula (6)
Energy Costs	EC	[\$/kWh]	0.075	
installed Power Costs	PC	[\$/kW]	2'745	$T \cdot (C1 - EC)$

Cost Calculation Method 2				
Present Value factor	PV(e,T)	[]	10.67	
Total Annual Costs 2	C2	[\$/yr]	12'921	formula (10)
Energy Costs	EC	[\$/kWh]	0.080	
installed Power Costs	PC	[\$/kW]	3'147	$T \cdot (C2 - EC)$

Cost Calculation Method 3				
initial Running Costs	RC ₀	[\$/yr]	5'000	
Annual Increase of RC ₀	c	[%]	5%	
Present Value factor	PV(q/(1+c),T)	[]	17.69	PV running costs
Total Annual Costs 3	C3	[\$/yr]	14'382	formula (16b)
Energy Costs	EC	[\$/kWh]	0.092	
installed Power Costs	PC	[\$/kW]	3'147	same as in method 2

Table 5 Example: results of cost calculations based on the methods explained at the beginning of this chapter.

key 1		User groups				total	remarks
		25 houses	1 mill	1 workshop			
	weight	1	3	4	32	weight per connection	
a) running costs	€	50%	5078 78.1%	539 9.4%	813 12.5%	6'500 100.0%	simplify by using mean running cost
b) installed power	[kW]	40%	20 39.2%	10 25.5%	18 35.3%	51 100.0%	the consumer installed power
c) consumed energy	[kWh]	10%	69'715 43.0%	49'406 30.5%	43'128 26.5%	162'250 100.0%	the sold energy
d) weighted average			59.0%	17.9%	23.0%	100.0%	weighted average of a, b & c

Table 6 Example: four proposals for key 1.

(all houses/mill/workshop = x% / y% / z%).

a) based on running costs: this key is assuming that the running costs are unevenly distributed among the connections. Therefore connections are weighted (here arbitrarily chosen 1 house counts as 1 connection, 1 mill as 3 connections and 1 workshop as 4 connections) = > key 1a = 78.1%/19.4%/12.5%.

b) based on the installed power (load side): key1b = 39.2%/125.5%/35.3%

c) based on the consumed energy: key1c = 43%/135.5%/26.6%

d) based on a weighted average between a, b & c: it is assumed that none of the above keys is appropriate, but some average would distribute the costs fairer. A weight based on the annual total costs is used (about 50% are operating costs (manpower, repair), 40% are kW costs (depreciation and interest) and 10% are kWh costs) to average keyl a-c = > keyld = 59%/17.9%/23.0%.

We could of course figure out any other keys and understandable and accepted by all. However, as combination to produce tariff structures. Using the shown in this part economics should come first to shown methods all will ensure enough income to make electrification viable. As a thumb rule we recover the expenses. How to select the right one? might base a tariff structure on: first cost analyses Finally we need one which appeals to all. To achieve (done), second revenue requirements (done) and this, perceived fairness is required. Fairness which is third fairness (which could be applied to select the tariff structure). If we decide to use for instance alternative four (Variant 4), we get the following tariff structure which obviously distributes the costs unevenly among the consumer groups. Is it fair? will they pay?:

Table 8 Example: Tariffs if Variant 4 is selected.

		house	mill	workshop
fixed charge	[\$]	23.82	90.39	116.09
kW charge	[\$]	-	-	-
kWh charge	[\$/kWh]	-	0.0220	0.0323

electricity bill	exclusiv	Variant 1 use key 1c				Variant 2 use key 1b				Variant 3 use key 1c				Variant 4 use key 1c			
		key1	key2	\$/m		key 1	key 2			key 1	key 2			key 1	key 2		
Household [\$ /mt /house]	40.33				17.33				15.82				17.33				23.82
fixed charge			100.0%	17.33				0.00			50.0%	8.67		59.0%	100.0%	23.82	
kW charge				0.00		39.2%	100.0%	15.82			40.0%	6.93				0.00	
kWh charge		43.0%		0.00				0.00		43.0%	10.0%	1.73				0.00	
Mill [\$ /mt]	1008.33				307.05				257.03				307.05				180.78
fixed charge			100.0%	307.05				0.00			50.0%	153.52		17.9%	50.0%	90.39	
kW charge				0.00		28.5%	100.0%	257.03			40.0%	122.82				0.00	
kWh charge		30.5%		0.00				0.00		30.5%	10.0%	30.70			50.0%	90.39	
Workshop [\$ /mt]	1008.33				288.03				355.68				288.03				232.18
fixed charge			100.0%	288.03				0.00			50.0%	134.01		23.0%	50.0%	118.09	
kW charge				0.00		35.3%	100.0%	355.68			40.0%	107.21				0.00	
kWh charge		26.6%		0.00				0.00		26.6%	10.0%	26.80			50.0%	116.09	
check revenues					12100				12100				12100				12100

Table 7 Example: four alternatives for electricity bills.

Each using one of the above defined key1 (a-d) and an arbitrarily fixed key2.

variant 1: energy consumption determines key1 (-> key1 c) and the bill is including one

fixed charge for all consumer groups (no meters needed).

variant 2: installed power determines key1 (-> key1 b) and the bill includes one kW charge for all consumer groups (no meters needed, but a group can influence its share by changing its installed power).

variant 3: the energy consumption determines key 1 (-> key 1 c) and the bill includes three charges, distributing the bill's total the same as the annum total costs (about 50% are operating costs (man power, repair) ->fixed charge, 40% are kW costs (depreciation and interest) -> kW charge and 10% are kWh costs ->kWh charge) . This is applied for all consumer groups. Meters are necessary for all connections and allow the customer to influence his bill by controlling the consumption.

variant 4: the average of key1 a-c is used to determine key1 (-> key1 d). For the household the bill shows a fixed charge (no meters needed). For the mill and the workshop half of the bill is a fixed charge and half of the bill is consumption-related (meters are needed).

No	consumer	No	description	rating power		power consumption in % of installed capacity during																one day					
				[V]	[kW]	P [kW]	1	2	3	4	5	6	7	8	9	10	11	12	13	14	15	16	17	18	19	20	
		1	cool&heat&light	240	0.80	0.80	10%	10%	10%	15%	30%	70%	80%	40%	20%	20%	20%	40%	60%	40%	20%	20%	20%	70%	100%	100%	8
	25 houses		subtotal			20.00	2.0	2.0	2.0	3.0	6.0	14.0	16.0	8.0	4.0	4.0	4.0	8.0	12.0	8.0	4.0	4.0	4.0	14.0	20.0	20.0	1
		1	heat & light	240	2.00	2.00	10%	10%	10%	10%	10%	10%	40%	100%	100%	100%	100%	100%	100%	100%	100%	100%	100%	100%	100%	10	
		1	motor	480	5.00	5.00	0%	0%	0%	0%	0%	0%	0%	90%	80%	90%	90%	90%	90%	90%	90%	90%	90%	90%	9		
		2	motors	480	3.00	6.00	0%	0%	0%	0%	0%	0%	0%	90%	90%	90%	90%	90%	90%	90%	90%	90%	90%	90%	9		
	1 mill		subtotal			13.00	0.2	0.2	0.2	0.2	0.2	0.2	0.8	11.9	11.9	11.9	11.9	11.9	11.9	11.9	11.9	11.9	11.9	11.9	11.9	1	
		25	tubelights	240	0.04	1.00	20%	20%	20%	20%	20%	20%	20%	100%	100%	100%	100%	100%	20%	100%	100%	100%	100%	50%	20%	20%	2
		2	motors	240	2.00	4.00	0%	0%	0%	0%	0%	0%	50%	80%	80%	80%	80%	80%	0%	80%	80%	80%	80%	50%	0%	0%	2
		1	motor	480	5.00	5.00	0%	0%	0%	0%	0%	0%	50%	80%	80%	80%	80%	80%	0%	80%	80%	80%	80%	50%	0%	0%	2
		1	el. welding	480	8.00	8.00	0%	0%	0%	0%	0%	0%	50%	70%	70%	70%	70%	70%	0%	80%	80%	80%	80%	50%	0%	0%	2
	1 workshop		subtotal			18.00	0.2	0.2	0.2	0.2	0.2	0.2	8.7	13.8	13.6	13.6	13.6	13.6	0.2	14.6	14.6	14.6	14.6	9.0	0.2	0.2	2
	supply		total	480		51.00	2.4	2.4	2.4	3.4	8.4	14.4	25.5	33.7	29.7	29.7	29.7	33.7	24.1	34.5	30.5	30.5	30.5	34.9	32.1	32.1	2

Table 3 Example: consumption during one day (24 hours)

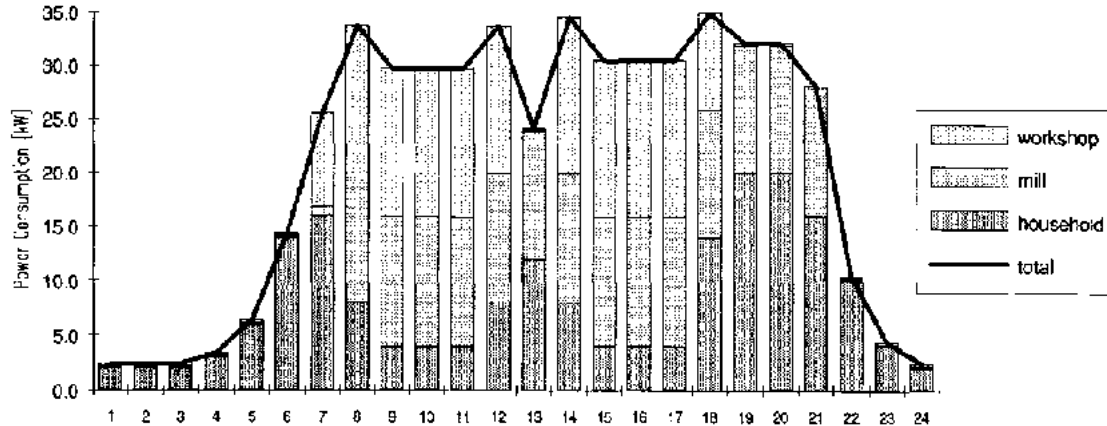

Fig 2 Example: hypothetical load curve during one day (24 hours)

[Home](#) > [ar](#) [cn](#) [de](#) [en](#) [es](#) [fr](#) [id](#) [it](#) [ph](#) [po](#) [ru](#) [sw](#)

Village Electrification (SKAT, 1992, 128 p.)

➔ **Part 9: Connection policy**

(introduction...)

1. General terms

2. Application and subscription

3. Connection fee and cost participation

4. Level change

5. Meters and distribution boxes

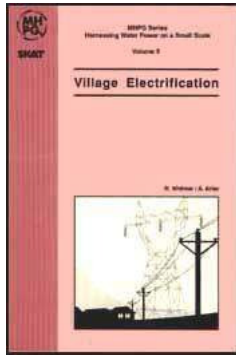

- 6. Meter reading, billing and payment
- 7. Sub-supply and sub metering
- 8. House installations and wiring
- 9. Extraordinary services
- 10. Legal terms

Village Electrification (SKAT, 1992, 128 p.)

Part 9: Connection policy

Terms of Electricity Distribution

This part is part of the ITECO article written for SKAT and used in this book as part 11: The Salleri Chialsa Venture. To improve the structure of the book it is extracted into this part 9.

Experiences show that the success of electrification also depends on the image of the supplier. The consumer's willingness to pay for the services depends on his perception of the energy supplier. Is he considered as fair, rule-based and trustworthy, difficulties like pilferage are largely reduced. In the Salleri Chialsa venture in Nepal the setting-up of an electricity company with the consumers as shareholders was an essential step. Part of this organization are the terms of electricity distribution, which shall be displayed here as an example. They are not meant to be copied, as they are the result of a process which is maybe more important than the terms of distribution. The perception of fairness needs the

participation of and acceptance by the consumer.

These rules, under the name of SCECO CONNECTION POLICY, are issued by the Board of Directors of Salleri Chialsa Electricity Company Ltd. (SCECO). They shall govern the connections and relations between the company and the customers and/or the consumers in the day-to-day business.

The legal frame of the Company is constituted in the 'Memorandum of Association' and the 'Articles of Association' of the Salleri Chialsa Electricity Company Ltd. from time to time.

1. General terms

- SCECO is a Public Company limited by Shares, incorporated on 6th Falgun 2047 under the Laws of Nepal;**
- SCECO shall distribute electricity of nominal 220/380 Volts (+-10%) and a frequency of 50 Hertz (cycles per second);**
- SCECO shall prosecute as per the Laws of Nepal, all harms and damages done to its properties;**
- SCECO is the legal owner and takes care of its generating, transmission and distribution system and the Service Drop Lines down to the entrance border of the Service Drop Cable into the customer's compound;**
- SCECO, after notice to the concerned parties, shall be entitled to access and to carry out works and to use private owned land for HT and LT poles and/or posses, for stays and brackets without any compensation;**
- SCECO shall be authorized to ask the land owners and responsible persons respectively**

to clear the HT and LT alignments and other sites of the electricity supply from trees and other obstacles which might disturb power distribution;

- SCECO may interrupt the power supply partly or totally for maintenance and repair. In other than emergency cases, SCECO shall inform the customers/consumers as soon as possible in an appropriate form (as a general rule notice will be given 24 hours in advance);

- SCECO declines all liabilities for danger and damages to third parties, caused by the existence of the electricity supply, by interruption of the electricity supply, by the use of electricity or by improper installations, house wiring, appliances, etc.;

- SCECO shall accept house installations and house wiring only according to the SCECO Technical Standards and pertinent rules. Before giving line, SCECO shall check the installations and the wiring and issue a so called attest to the customer,

- SCECO shall not accept any interferences with the supply system by third parties due to inappropriate behavior, house installations, wiring, appliances, etc., and shall suspend/ interrupt immediately the electricity supply without any notice;

- SCECO shall be entitled to check the power factor at the Service Connection. The power factor (of consumers >100 W) shall be >0.8. SCECO shall charge the customer/ consumer for all necessary remedies.

Tariffs

The SCECO Tariff is divided into 3 categories and 5 levels which are defined by the possible power consumption during peak and off-peak periods;

The categories and levels shall be defined as:

Category	Level	Particulars
Domestic	Level 1	light
	Level 2	light, radio, "bijuli dekchi"
	Level 3	light, radio, cooking/heating
Services	Level 4	govt. offices, business & services, restaurants & lodges, cottage industries etc. with considerable power consumption during off-peak and peak hours
Industry	Level 5	with high 3 phase power consumption (8kW <P <20kW) during off peak hours

Table 1 description of the different connection categories and levels.

The SCECO Tariff structure is mainly built on the fact that the majority of the connections is not metered and that the power consumption at the consumer's service connection is limited by technical means (MCCB located in the sub distribution box of SCECO). They automatically cut out when the admitted power is exceeded. For reconnection the consumer has to pay a reconnection fee;

- Every Tariff level has a fixed rate, which partly reflects the cost of the admitted power and partly is due to the fixed investment costs inherent in every Service Connection;
- Level 1 and 2 pay a fixed rate only and are not equipped with meters. Level 3, 4 and 5 are metered and have to pay a fixed rate as well as differentiated prices perconsumed unit (kWh);
- A special industrial level (level 5) is designed to promote the daily consumption, whereas during peak hours (evening and maybe morning) the possible power consumption is compulsorily reduced to I 00 Watts, 500 Watts or 2000 Watts, according

to level 5/1, level 5/ 2 and level 5/3.

2. Application and subscription

In any matter related to the supply of electricity the Company shall deal with the house owner or the authorized representative or such other person(s) deemed appropriate by the management. The pertinent power of attorney shall be submitted to the Company;

SCECO shall be informed on sales of electrified buildings and hand-over of such buildings by copy of the pertinent deeds of the "land revenue office". An application (SCECO Form) for name endorsement shall be duly filled in and signed by the parties;

The application form will be made available upon payment of NRs 10/- each at the SCECO office;

People desirous to electrify their compound, premises or house have to submit to SCECO a written application for a connection as per application form (SCECO Form) with the implication that they shall be governed by the rules and regulations of SCECO;

The application form will be made available upon payment of NRs 10/- each at the SCECO office;

As per rules and principle, the Company shall erect the Service Connection to each domestic house and/or condominium apartment (property) only;

The Company may exceptionally decide to give two separate lines to a same and only house, if deemed necessary. This applies specially to the industrial level in living houses; The Tariff category and level shall be fixed by the Company and will be checked and down/upgraded from time to time as per actual level criteria ("Domestic", "Services" or "Industry"). Houses with different level categories of the several adopters shall be

granted in principle the level of the "highest" applicant;

At the initial application the level for "Domestic" connections within the levels I, 2 and 3 is optional;

With the application for level 4 "Services" and 5 "Industry" evidence of the intended business and estimate of power consumption must be submitted to the company. Level 4 and level 5 will be granted only by the Company, if the conditions (technical feasibility, economic aspects and category criteria) are fulfilled;

The initially agreed level, as a general rule, shall not be changed;

The connection fee falls due and shall not be reimbursed to the customer under any circumstances;

The notice period is three months (see legal terms).

3. Connection fee and cost participation

- SCECO, on receiving a duly signed application form for a connection, shall conduct a survey and establish a cost estimate for the connection. If the connection proves technically and economically feasible, the applicant shall be informed about his/her (compulsory) cost participation as per the Company's rules and rates. The Board of Directors of the Company, from time to time, shall fix the cost participation modalities and rates;

- The cost of the Service Connection have to be paid in full and in advance by the customer. Nevertheless, if the applicant is a 'domiciled house holder' and the connection is a first electrification (and not an upgrading of an already existing connection), the applicant has to pay only a cost participation, which is calculated as follows:

Length of the connection from Sub-Distribution Box to the house, minus 65 meters, multiplied by the rate as per SCECO rules (SCECO Cost Participation Form)

- As the connection at the time of application is not yet erected, the connection length is determined on the basis of the geographical plan view (map), multiplied by 1.2 (i.e. additional 20% to avoid topographical hazards).

Additional materials delivered by SCECO for the Service Connection (connection boxes, connectors, etc.) and the earthing equipment as per SCECO Technical Standards) shall be billed separately;

With the payment of the connection fee the applicant gets (the right to be) connected to the supply grid of the company and to draw electric power as per Tariff level:

Level max Power [kW]

- 1 0.1
- 2 0.5
- 3 2.0
- 4 up to 8.0
- 5 more than 8*)

Table 2 Maximum power per level

***) to tee fixed by the Company; peak hours reduced to levee I, 2 or 3 (see Tariff)**

In any ease the tap-off power shall be allotted according to the technical possibilities and to the already existing cable capacity (e.g. 1.5 kW instead of 2 kW in level 3, monthly billing as per level 3 or 4 kW instead of 8 kW in level 4, monthly billing as per level 4);

If the request for a new connection is granted by the Company, the applicant has to pay in advance within 20 days from the date of application:

The cost participation as per application form

The connection fee:

Level NRs

1	250/-
2	500/-
3	1000/-
4	1500/-
5	1500/-

Table 3 connection fees for the different levels.

If an applicant is a "domiciled house holder", his/her connection fee shall be converted into ordinary shares of NRs 10/- each. If he/she is not a "domiciled house holder", he/she is not entitled to shares but, as long as he/she is connected to the supply grid of the company, has a claim on electric power as per level. (Regarding share holding see Memorandum and Articles of Association of the Company.)

4. Level change

Customers desirous to change the connection level have to follow the Company's application procedure similar to the application for a new connection;

The application form will be made available upon payment of NRs 10/- for each at the SCECO office:

During the application procedure and period the existing level shall be maintained. Change of level occurs at the end of a month;

- Applications for downward change of level will be granted only after 3 months from the application date. Shares will be possibly and accordingly reduced and refunded at face value. The Company shall take care of the shares;

- If the application goes for a higher level within the domestic category, the Company will check whether power generation, grid and Service Drop Cable capacity are sufficient. If the investigations show a positive result, the upward change of level will be authorized by the Company. In any case, the applicant has to pay the difference of the connection fee;

- If the bottle neck is located in the Service Drop Cable of the individual house connection only, the power supply shall be restricted to the technically possible limits (e.g. 1.5 kW instead of 2 kW in level 3 (monthly billing as per level 3) or 4 kW instead of 8 kW in level 4 (monthly billing as per level 4);

- Exchange of a Service Drop Cable for higher power is possible in principle if:

- The applicant is entitled as per definition of the "category"

- The technical conditions are favorable

- The applicant is willing to pay the full costs of new connection (cable, trench, accessories, labour, house wiring, etc.)

Nevertheless applications for upgrading domestic, levels to level 4 and 5 will be investigated thoroughly, not only technically but also economically No such application shall be granted unless the conditions of the level categories are fulfilled.

5. Meters and distribution boxes

- Meters shall be property of the Company and shall be installed free of charge. If the meter is lost, stolen or damaged, the customer will be disconnected and shall have to pay the damage. Consequently, in case of supply of electricity again, the customer shall have to pay the reconnection fees;**
- The meter shall be sealed by the Company's seal. Any impairment of a meter or a seal shall be charged with a fine of NRs 300/- and the Service Connection might be disconnected;**
- Meters shall be periodically tested and hand calibrated by the Company;**
- Sub Distribution Boxes are property of the Company and shall be installed free of charges. Forceful damages shall be indemnified by the customers connected through the concerned Sub Distribution Box. The connection shall not be switched on until and unless the customers acknowledge in writing the damage and the indemnity.**

6. Meter reading, billing and payment

Consumers shall have individual SCECO Customer Cards with the records of the monthly meter readings (level 3, 4 and 5), the monthly amount due and the signature of receipt of the Company. This card shall be available on the meter reading date at the customer's premises as well as on the payment day at the SCECO Head Office;

Lost Customer Cards shall be replaced against a deposit of NRs 10/- with SCECO,

Meter reading date shall be the 1 st and 2nd day of the month, if not a Saturday;

On the meter reading date the meter must be accessible and the Customer Card must be

available for the SCECO staff in charge. Otherwise a lump sum shall be billed as per the last bill and the estimated consumption of the consumer;

The customer/consumer has to pay the electricity bill as per Customer Card and surcharges as per possible additional bills within the period of the first 15 days following the billing month. Otherwise SCECO shall charge a late payment fee of NRs 51- per half month for each bill:

Table 4 Surcharges in case of delayed electricity bill payment.

max. delay [days] surcharge [NRs]

15	0/
30	5/
45	10/
60	15/
75	20/
90	25/

If the bills are not paid within three months (from the billing date), SCECO shall disconnect the line and the customer shall have to pay the reconnection fee;

The fixed rate of the tariff is due independent on the electricity consumption and supply.

7. Sub-supply and sub metering

- The customer/consumer is not allowed in any case to extend Service Connections to other buildings and consequently neither to supply nor to sell electricity to other houses and premises. If any bad intention is proved, the supply of electricity to the respective

customer/consumer shall be terminated. Reconnection is only possible after a thorough investigation of the facts. Reconnection will be charged;

SCECO tolerates sub-metering with privately owned meters between several parties in a house, sharing one and the same connection. The wiring and installation have to be made according to the SCECO Technical Standards. Nevertheless, it is understood that the reading of the sub-meter is not relevant and in no way an argument to the Company.

8. House installations and wiring

Loose and inappropriate wiring shall be rejected by the Company;

Service Connections supplying one or more power sockets for electrical appliances (level 2, 3, 4, 5) must be compulsorily provided with earthing facilities as per SCECO Technical Standards;

SCECO shall check the house installations and the wiring and issue a so called Attest to the customer duly signed by the SCECO General Manager,

The recommendation goes to the customers to call for such wiring work "wire-men" certified by SCECO;

The connection will not be switched on until and unless the house wiring is proved safe and according to the "SCECO Technical Standards";

SCECO shall check periodically the house installations and wiring for safety;

The connection may be disconnected until and unless the house wiring is proved safe and according to the SCECO Technical Standards; The right of connection will be permanently or temporarily withdrawn, should wiring become unsafe or abuse occur. Payments

(connection fee, possible cost participations and others) are in no case refunded.

9. Extraordinary services

Extra services, e.g. for temporary connections, temporary upgrading, etc. may be offered by the Company at full costs paid in advance if the SCECO Safety Standards are fulfilled. The Tariff applied for such extras will be fixed from time to time by the SCECO management in the pertinent rules.

10. Legal terms

- The Notice Period for all changes in the relation between the customer and the Company (level change, request for temporary disconnection, temporary level upgrading, etc.) shall be three months beginning with the submission of a written, duly signed notice (and receipt) to the concerned party;

The prescription period for all litigations regarding electricity supply and/or related matters shall be 1 year from the time of the written notice;

SCECO shall not be liable in whatever way for any injury or casualty caused by electricity.



[Home](#)"" """"""> [ar.cn.de.en.es.fr.id.it.ph.po.ru.sw](#)

 **Village Electrification (SKAT, 1992, 128 p.)**

  **Part 10: Typical application examples**

 **(introduction...)**

 **1. Introduction**

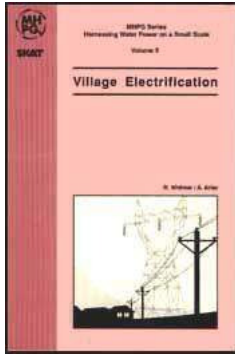

- 2. Namche bazar (category a)
- 3. Chame (category b)
- 4. Syangja (category c)

Village Electrification (SKAT, 1992, 128 p.)

Part 10: Typical application examples

from Nepal

1. Introduction

Hereunder some case studies of the electrical control system for three MHP schemes in Nepal will be presented.

The equipment of all three plants has been designed, supplied and set into operation by BYS. The electrical control systems have basically been designed in line with the concept outlined in chapter 1.2, though a few additional options regarding protection have been incorporated.

2. Namche bazar (category a)

The Namche MHP scheme was executed by BYS on a turn key basis.

2.1 Operating Conditions:

net head: 75 m max turbine discharge: 651/s

plant capacity: 27 kW_e

altitude: 3500 m a. s .1.

load type: lighting and heating (mostly resistive)

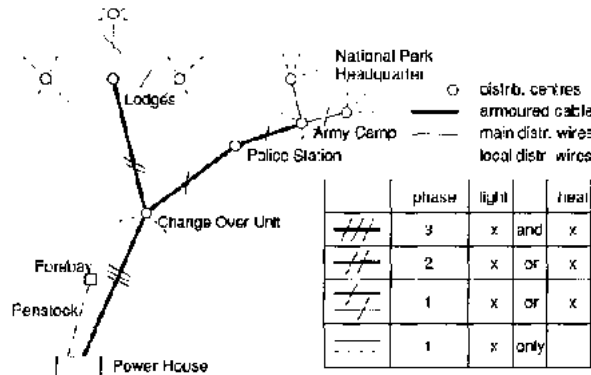

Figure 1 Schematic transmission and distribution system.

2.2 Generating Equipment:

turbine: BYS splitflow

generator: Markon (U.K.), synchronous 3F, brushless type, 37.5 kVA, 230/400 V, 50 Hz

speed control: manual flow regulator

speed transmission: not required

penstock valve: gate valve

control panel: BYS standard control, protection and instrumentation cubicle category A, see below for details

2.3 Electrical Design Considerations,

Components and Wiring Details

As the site is located 3500 m a.s.l. where the air density is low, a deration factor of approx. 0.85 needs to be considered to keep the generator from getting overheated. Required rated power of the generator kW =

$$\frac{\text{plant rating}}{\text{deration factor}} = \frac{27\text{kWe}}{0.85} = 31.76\text{kW}$$

As the loads are mostly lighting, heating and cooking with very low overall inductance, the power factor may be assumed close to unity. To be on the safer side, assuming a lagging pf = 0.9, requires a kVA rating of the generator of

$$\frac{\text{generator kW rating}}{\text{power factor}} = \frac{31.76\text{kWe}}{0.9} = 35.3\text{ kVA}$$

The nearest, higher-rated, standard size generator used at site is 37.5 kVA, which with 6% above the estimated value, is safe enough. The generator selected is of brushless-type with an electronical automatic voltage regulator, which has resulted in a constant generator voltage. Even at varying speeds (as the equipment is manually governed) down to 90 % of the rated speed the voltage is stable, below that the generator voltage falls proportionally to the speed. Both features also result in low maintenance requirements and are best suited to the site's remoteness.

The total load actually exceeds the plant's installed capacity, therefore, manual load management is practised to keep the generator from overloading and, at the same time, to

maximize the load factor. The load centres are several 100 m away from the powerhouse and are connected through an underground cable network. As Namche Bazar is a touristic centre this solution was also chosen considering esthetics. Most of the lodges, requiring much heating and cooking power, are connected by two different lines to the distribution centre, one line for lighting only and the other for cooking and heating. Load management is done by switching these lines remotely from the power house by remote controlled air break contactors. They are housed in a sheet metal enclosure at the distribution centre.

The main control, protection and instrumentation features of the equipment in the power house include: heating/lighting line on/off selector switches, circuit breaker back-up fuses, over voltage relay, excitation/ de-excitation system, time totalizer, energy meter, kW meter, ammeter, voltage meter, frequency meter, instrument current transformers and indicating lamps. A phase selector switch is added to connect the power house load (lighting and cooking for the operator) to the least loaded phase, to improve the phase balance.

3. Chame (category b)

BYS scope of work was limited to the design, supply and installation of the generating equipment only.

3.1 Operating Conditions:

net head: 65 m

max turbine discharge: 130 Vs

plant capacity: 45 kKWe

altitude: 3000 m a.s.l.

load type: lighting, heating, radio, tape recorders etc.

3.2 Generating Equipment:

turbine: BYS crossflow T6

generator: Leroy Somer (France), 230/400 V, 50 Hz

speed control: automatic oil hydraulic, mechanical governor

speed transmission: not required

penstock valve: gate valve

control panel: BYS standard control, protection and instrumentation cubicle category B, see below for details.

3.3 Electrical Design Considerations, Components and Wiring Details

The site is located at approximately 3000 m a.s.l., therefore, a deration factor of 0.88 is to be applied. Although most of the loads are resistive, a power factor of 0.8 is considered.

The required generator kVA is therefore:

generator rating kVA =

$$\frac{\text{plant rating}}{(\text{deration factor})(\text{power factor})} = \frac{40\text{kWe}}{(0.88)(0.8)} = 57\text{kVA}$$

The generator used at this site is a 100kVA frame, which is actually much too big. The reason for using this generator was that it was originally selected for another site, which turned out to be not feasible. As there was no way to return the generator and no other, more adequate site, it was selected. The generator is a brush less type with electronic automatic voltage regulator.

The automatic flow controlling governor with the generator AVR keeps the voltage and frequency within internationally accepted limits at all operating conditions.

The main control, protection and instrumentation features of the control panel are excitation/de- excitation system, over and under voltage relays, solid state over current relay (inverse time characteristics), circuit breakers, earth fault relay (RCCB type),

Voltmeter, Ampmeter, KW meter, energy meter, time totalizer, frequency meter, instrument current transformers, and status indicating lamps.

Photographs, circuit diagram and component list of the control cubicle are given in the next page.

4. Syangja (category c)

BYS' scope of work was limited to the design, supply and installation of the generating equipment only.

4.1 Operating Conditions:

net head: 13.3 m max turbine discharge (unit) 4251/s plant capacity: 2 x 40 kWe altitude: below 1000 m load type: lighting, heating and motor loads

4.2 Generating Equipment:

turbines: BYS crossflow T7

generators: Markon (UK), Brushless 230/400 V, 50 Hz

speed controls: automatic water hydrau lic, mechanical governor

speed transmission: V-belt drive

penstock valves: gate valve

control & synch. panel: BYS standard control, protection, instrumentation and synchronisation

cubicles category C, see below for details.

4.3 Electrical Design Considerations, Components and Wiring Details

The site is located below 1000 m.s.l., therefore, no aeration factor needs to be applied to

**the generator rating. Load types are such that the worst case power factor at full load is better than 0.8 lagging. The required generator kVA rating is therefore:
generator rating kVA =**

$$\frac{\text{generator rating kW}}{\text{power factor}} = \frac{40\text{kW}}{0.8} = 50\text{kVA}$$

The nearest standard size generator used at site is 62.5 kVA, which is on the safer side (+12%). The two generators used are both brushless with an electronic automatic voltage regulator. Droop kit for reactive load sharing and short circuit maintenance unit are installed in the generator terminal box itself. There are in total 3 control cubicles, namely generator control panel 1, generator control panel 2 and synchronisation panel. The main control, protection, synchronising and instrumentation features of the equipment comprise of excitation and de-excitation control system, air break contactor control system, overvoltage relay, under voltage relay, switch-fuses unit, solid state over current relays, earth fault relay (RCCB type), voltmeter ampmeter instrument, transformers, power relay, time totalizer, frequency meter, kW-meter, energy meter, auto/manual synchronising system, status indicating lamps and feeder circuit breaker.

The design of the synchronisation control circuit allows for both synchronising of the two units and paralleling with the grid.



[Home](#)''' '''> [ar.cn.de.en.es.fr.id.it.ph.po.ru.sw](#)

 **Village Electrification (SKAT, 1992, 128 p.)**

  **Part 11: The salleri chialsa venture**

 **(introduction...)**

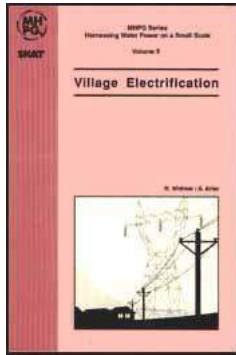

1. Introduction
2. Energy and hydro power
3. The small hydro power sector
4. The history of the salleri chialsa small hydro power project
5. The setting
6. Construction and features of plant and grid
7. Design and technical data
8. Operation
9. Management by a shareholder company
10. Conclusions

Village Electrification (SKAT, 1992, 128 p.)

Part 11: The salleri chialsa venture

This article has been written by the Company for International Technical Cooperation and Development of Switzerland, ITECO, for this SKAT publication.

1 Introduction

At present about 94% of Nepal's population resides in rural areas and only two percent of the rural population has access to electricity. A serious energy and power deficit exists in most of Nepal's rural areas, but especially in remote areas which are not linked to the national electricity grid and have only limited access to commercial fuels. Nepal's vaste hydropower potential has Ied planners and engineers to exploit this resource since long. Already many small hydropower plants exist, but most lack any possibility to increase their capacity or additional investments are not feasible. So new schemes need to be constructed.

Operation, maintenance and socioeconomic implementation of new energy structures (like electricity generation and distribution) in the cultural environment of Nepal seem to be difficult and their success doubtful. Simple rules, based on long term experiences, are not available. Knowhow and experience transfer from one area to another has not yet proved feasible.

It is commonly said that small hydropower plants are uneconomic because of their poor station (or load) factor (i.e. low utilization of investment), high engineering and overhead costs, inconsistent equipment and lack of spare parts. Obviously the cost of electric energy generated in isolated small hydropower plants must be higher than urban supply.

As a matter of fact a Ten Year Rural Electrification Strategy and Plan Study has shown that even for a minimum service, the unit rates (price for one kWh) will compulsorily be higher than the present official tariff of the Nepal Electricity Authority (NEA). But rural Nepalese in most parts of the country are so impoverished that the majority may not be able to bear the actual costs of electricity. That is the reason why development of small hydropower plants should not be seen and promoted independently from the development of other infrastructural, economic and social aspects.

2. Energy and hydro power

The two principal indigenous energy resources in Nepal are forests and extensive river systems. Table 1 below shows that roughly 94% of the primary energy originates from Nepal, but unfortunately almost four fifth are firewood.

The present area of forest is estimated at some 30'000 km². Population pressure and the increasing demand for arable land and forest products have reduced forest cover by half in the last 20 years since 1970. At present annual firewood consumption is of some 10 million tons. Under the assumption of a "moderate afforestation program " of yearly 500 km², projections of the UNDP/World Bank anticipate the virtual disappearance of Nepal's

forests by the year 2010. The greatest scope for increasing firewood supplies, in the short and medium term, will be through improved management of the existing forests, including forest protection, i.e. elimination of misuse. Improvements in the transformation process into final energy and substitution of other energy resources where and whenever possible will also support to reduce deforestation.

Nepal has a considerable hydropower potential of about 83'000 MW. 27'000 MW have been investigated for development. But many of the considered plants are of a dimension that would require joint ventures and export of electricity to the Indian power market to be economically justified.

The currently installed hydro power capacity in Nepal is about 240 MW, including the recently inaugurated Marshyangdi power plant. To date most of the hydropower development has focused on projects shaped to meet domestic requirements which have resulted in low specific utilization and high unit costs.

Table 1 Primary Energy Statistics of Nepal: estimated and updated structure of primary energy consumption in 1988/89.

Particulars	in billion kWh [TWh]	[%]
Indigenous:		
Firewood	37.6	73.7
Dung/Residues	9.5	18.6
Hydro Electricity	0.8	1.6
Imports:		
Electricity	0.2	0.4
Petrol	2.3	4.5
Coal/Lignite	0.6	1.2

Total	51.0	100.0

Table 1 for instance shows that the available average annual primary energy demand per capita is in the range of 2500 to 3000 kWh, compared to 30'000 to 40'000 kWh, typical figures for Western countries. In this context the total efficiency of the energy transformation process to the end use is of great importance. The probable figure in Nepal (with many open fire places) is less than 10%, whereas in western countries it is between 40 to 50% (45% in Switzerland)!

3. The small hydro power sector

Small Hydro Power Schemes are defined to be of a capacity of more than 100 kW and less or equal to 5 MW.

In the last years the small hydro power sector in Nepal has made good progress, although the result is far below the necessity and the initial expectations of the early sixties. Potential promoters have been discouraged to replicate the few successful examples on a wider scale. The reasons are many: insufficient analyses of potential sites, lack of appropriate hydrological data, bureaucratic delays, extremely high specific investment costs (typical US\$ 3 000 to 5 000 or more per kW), institutional shortcomings, lack of clearly defined goals, inadequate tariff and connection policy, overstaffing, untrained administrative and technical staff...

At present the overall installed capacity in small hydropower plants is almost 12 MW, less than 5% of the installed national generating capacity.

	under construction	in operation
Number	7	34

Capacity [kW]	7 650	11 239
---------------	-------	--------

Table 2 Present situation Small Hydro Power Plants (up to 5 000 kW) according to SHPD Nepal.

Most of these stations are or will be operated by NEA and its Small Hydro Power Department (SHPD).

4. The history of the salleri chialsa small hydro power project

The relevant history of the Salleri Chialsa Project began in the late fifties, after the people's revolt in Tibet and its suppression by the Chinese. At that time thousands of Tibetan refugees moved into eastern Nepal and settled among the TibetoBurmese ethnic groups (Gurung, Limbu, Magar, Rai, Sherpa, Tamang) in the district of Solukhumbu. With the aid from various international organizations, His Majesty's Government of Nepal started a programme in 1960 to help resettle the refugees and founded (among others) the Tibetan Community of Chialsa. Most of the Tibetan families in the community economically depend on handicraft. The handicraft center with its carpet factory, where the raw wool is prepared, washed, spun, dyed and where the carpets are woven is still today the most important source of income for these Tibetans.

Dying of wool is a very energy intensive procedure and the heating has always been done with firewood. The efficiency of the open fire method is deplorably bad and the firewood consumption high. The total primary energy consumption during the period 1960 to 1987 is an estimated 2500 tons of firewood representing some 10 million kWh. To avoid such an ecologically and socially unacceptable use of firewood the Swiss Government through its Swiss Development Cooperation (SDC Nepal), consequently decided to electrify the Chialsa handicraft center by construction of a small hydel in the vicinity. This was the

Salleri-Chialsa Small Hydel. The first investigations were made by the Swiss Association for Technical Assistance (SATA) in 1960. By 1962 SATA was ready to install a hydro power station. Survey and design had been carried out and a water gauge erected. In 1964 the decision making authorities postponed the project by 5 years! They claimed that the available data were not reliable enough to economically justify the plant's construction.

Due to this and other setbacks during the initial construction phase of the small hydro plant, the first electrically dyed wool left the newly built dye house in March 1987 only. Since that time two electrical dye vats, proposed and installed by the consultant, have been operated with a remarkably high availability. Electricity (hydro) is obviously cheaper, cleaner and ecologically harmless.

5. The setting

The Salleri Chialsa power station is situated in Salleri Village Panchayat of Solukhumbu District, eastern Nepal. Like most other mountainous districts in Nepal, Solukhumbu District suffers from a severe lack of essential infrastructure such as roads, bridges, drinking water supply, telecommunication facilities and health services.

The economy is based on agriculture, forestry, trade, handicraft, and a little tourism. The climate is rough (down to minus 10°C in winter) and often humid. Agricultural production is insufficient to cover the basic needs of the district so that imports from the southern part of the country (Terse) and India are necessary.

6. Construction and features of plant and grid

A first project was initiated in 1976 and construction activities took place in the following years. But several times landslides tore away part of the almost completed head race canal. For technical as well as for political reasons it was then decided to close down the first phase of construction.

In 1984, after site preparation, slope stabilization and afforestation in 1983, the Swiss Development Cooperation and His Majesty's Government of Nepal agreed to reanimate the works and to construct a 400 kW Hydel on the Solukhola in Salleri, designed for two generating groups of a rated capacity of 200 kW each. As the load estimates for the first years were rather low, the promoters decided to install only one generating group initially. The engineering work was entrusted to ITECO. The power station began to produce electricity in February 1986. The 11 kV lines, with a length of roughly 10km, supply a distribution grid which was built up step by step from 1987 to 1990.

Up to now more than 400 houses are connected to the supply grid and about 2500 to 3000 people are directly benefitting from electricity. In the present supply area there are three significant industries, the

Chialsa Handicraft Center (as mentioned before), the Sagarmatha Water Turbine, a small enterprise for woodwork, paper production and cereal milling, and a recently inaugurated Bakery. The monthly consumption in the industrial tariff level is about 4'000 to 4'500 kWh. The annual total in the Fiscal Year 1990/1991 was of 42 872 kWh, i.e. roughly 9% of the total electricity sales.

The distribution system, when fully developed in 1993, will cover parts of Salleri Panchayat and Garma Panchayat, with 4000 to 5000 people as potential end users. This implies the installation of a second generating unit and the extension of the 11 kV lines of today 10 to about 20 km.

The target number for the project is 750 to 800 connections with about 7 to 10 new or newly electrified industries and about 20 cottage industries. The industries will increase the day load and also create new income sources and jobs for the area.

7. Design and technical data

The power plant is a 'classical' run-of-the river scheme, designed for 400 (maximum 500) kW hydraulic gross capacity and two generating units.

At present it is equipped with only one turbine! alternator group of 180 kW nominal output capacity. The hydraulic layout is such that it can be run at full capacity the whole year. The possible electricity generation is in the range of 1.5 million kWh per year; this figure will increase to 3 million kWh after the implementation of the second generating group during the second phase of the Salleri-Chialsa Electrification and Utilisation Project (SELUP).

The grid consists of 3 phase I I kV transmission lines, a 3 phase main low tension grid with peripheral sub-distribution boxes and the three or single phase service drop cables to the houses. This system can easily provide a supply in three or single phase to small and cottage industries.

8. Operation

Key figures are presented in the Table 3 below. Some more details are displayed at the end of this part.

The consumer distribution substantially increased in the last two years since a clear and firm connection policy and sales promotion were implemented and the small business and industry promotion effectively supported by the SELUP.



Fig 1a Area map of the power plant.

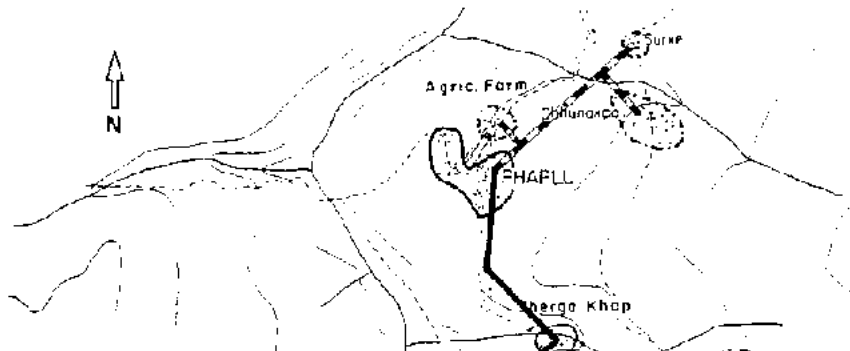

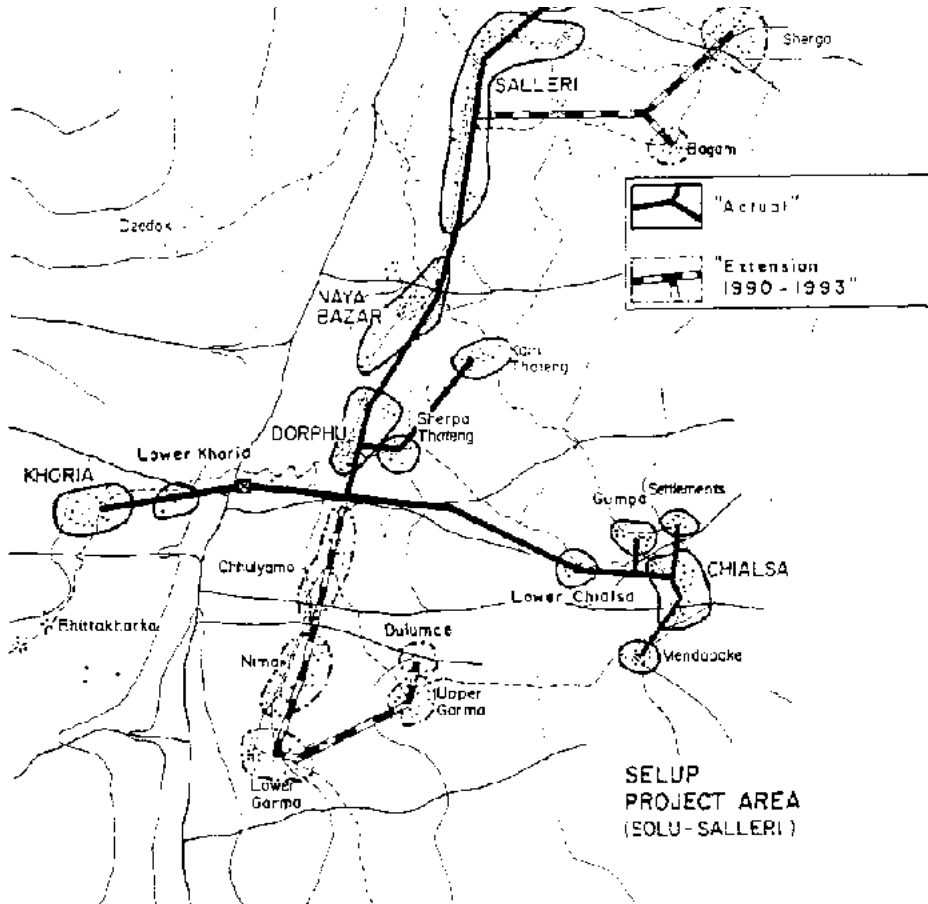

Fig 1b Situation map of the power plant

Fiscal Year (12 month)	1990/91	1989/90	Growth [%]
Total consumer distribution [kWh]	485'003	367'701	22
Internal Consumption [kWh]	25396	31'289	
System Losses and street lighting [kWh]	34807	29477	
Total Generation [kWh]	545'207	458'467	18
Peak Load [kW]	156	144	8
Utilization Time of Peak [hrs] (%):	3'495 (24)	3'184 (37)	
Running Time of Plant	98%	97%	
Station Factor	34%	29%	18

Table 3 Key Figures of Plant Operation

The Station Factor of the Salleri Plant is in the Nepali Context remarkably high. Annual average figures of nearly 35% are rather seldom for an isolated rural power plant. In Dec 90/Jan 91 the Station Factor was even slightly more than 40 %!

9. Management by a shareholder company

A Conceptual Input Study in 1987 found that the preferred organizational form for the Utility was the Joint Ownership/Share Company. The Share Company structure was considered to be more suitable than the "cooperative" to achieve the intended goals since it offers financial stimulus to the partners and permits differentiated economic activities (reinvestment, diversification, etc) if wished by the share holders.

Preparatory work was done by a small group in Nepal (one member was an expatriate). This cooperation in legal matters and the experiences gained on both sides were extremely fruitful and stimulating.

In autumn 1989, after the basic legal papers of the Company (the Memorandum of Association and the Articles of Association) were signed by the promoters, His Majesty's Government of Nepal and SDC/N, the documents were submitted to the Ministry of

Industries for registration of the Salleri Chialsa Electricity Company (SCECO), public limited by shares.

In many respects SCECO is a pioneer project. Since the constitution of Nepal allocates the authority for electricity generation and distribution to the Nepal Electricity Authority exclusively, SCECO is the one and only exception of a private electricity utility. At present there is no similar case in Nepal.

In February 1991, after a long period of discussions about legal aspects of the venture within His Majesty's Government, the Company was finally registered and established.

Based on the legal papers of the Company, 'internal' and 'external' rules and regulations were drafted.

The 'internal' rules are known as the Service Rules of SCECO. They are designed to define the structure of the Company and the conditions of service, employment, recruitment, promotion and discipline of the staff of the Company.

The 'external' rules are known as the Tariff and connection Policy of SCECO. They define the mutual rights and obligations of the SCECO and its customers/ consumers respectively.

9.2 Summary of the "TARIFF and CONNECTION POLICY" of SCECO

In 1989 the need for an appropriate, coherent tariff and connection policy became urgent. The frame work of such a policy, designed in the Conceptual Input Study, was not comprehensive enough to avoid "bad exceptions", "unacceptable privileges" and "spontaneous rules" which later could lead to unforeseen problems. So, frequent up and

downgrading of tariff levels, late payment, extremely short notice periods (e.g. one day), extensive and costly service drop installations without any cost participation by the customer were the rule. All this kept the SCECO team too busy to attend to the policy development, needed to break the vicious circle.

The following paragraphs give a summary of the 'Tariff and Connection Policy' of SCECO:

The SCECO tariff is mainly based on the fact that a greater part of the connections are not metered and that individual Load Control Switches limit the off take of power as per tariff levels. These Load Control Switches automatically cut out when the permitted power off-take is exceeded. Reconnection can only be done by the SCECO staff.

The tariff is divided into 5 levels defined by the permissible power off-take during peak and off-peak times. A special industrial level was designed to promote day and off-peak consumption.

Every tariff level has to pay a fixed rate which reflects partly the cost of the allowed power taking and partly is due to the fixed costs related to every connection. Levels 1 and 2 pay a fixed rate only and are not equipped with meters. Levels 3, 4 and 5 are metered and have to pay a fixed rate as well as a differentiated, degressive price per consumed unit (kWh).

Levels 1, 2 and 3 are grouped in the 'Domestic' category with maximum power consumptions of 0. 1, 0.5 and 2 kW respectively; level 4, known as the 'Service' category, covers connections of schools, hospitals, hotels and lodges, governmental offices and cottage industries with a maximum power consumption of 8 kW; level 5, the 'Industry' category, is specially designed to promote day consumption by low unit prices. It allows an off-peak power consumption of 10 kW or more and is drastically curtailed during the peak hours by a clock relay device.

The consumer has to pay his electricity bill and any other charges (e.g. reconnection fees

and late payment surcharges, etc.) during the first 15 days of the next month. Otherwise SCECO will charge a late payment fee.

People wishing to have an electrical connection on to their house or premises have to submit a written application to SCECO. The company allows only one connection to each domestic house, condominium or apartment (property).

If the request for a new connection is granted by the company, the applicant has to advance payment for: - The cost participation as per application form or bill

- The connection fee

Level NRs

1	250/
2	500/
3	1 000/
4	1 500/
5	1500/

Table 4 Connection fees for the different consumption levels

With the payment of the connection fee the applicant is entitled to be connected to the supply grid of the company and to claim electrical power as per tariff level (and according to the technical possibilities at the tap off point).

Table 5 Maximum power consumption for the different levels

Level max Power 1kW

- 1 0.1
- 2 0.5
- 3 2.0
- 4 4.0 to 8.0
- 5 to be fixed by the company;

If an applicant is a "domiciled house holder", the eonnection fee is automatically converted into ordinary shares of NRs 10/- eaeh. If not, the applicant is not entitled to shares but, as long as connected to the supply grid of the company, he has a claim to electrical power at the designated level. Note: 'domiciled house holder's are either people who normally reside or companies whose registered offices or places of work are within the supply area and who are connected (or on the way to) to the electric grid of the company.

The period of notice of the connection by the customer is 3 months. This period applies to all changes required by the customer (disconnection, change of level, ...).

Exchange of a service drop cable for higher power is possible in principle if:

- The applicant is entitled to a higher level. - The technical conditions are favorable.**
- The applicant is willing to pay the full costs of a new connection (cable, trench, accessories, labour, house wiring, etc).**

The connection will not be switched on until the house wiring has been checked for safety by the company. The right of connection will be permanently or temporarily withdrawn, if the wiring becomes dangerous or abuse occurs.

The meters are the property of the company and shall be installed and maintained free of

charge.

9.2.1 Meter Calibration, Pilferage

Meter calibration is done by the staff periodically with a standard Watt hour meter.

Pilferage, so far, is not a problem, since the majority of the connections is not metered at all and the low tension distribution system consists of underground cables.

9.2.2 Administration

The management of an electricity utility and share holder company with only 8 staff (only two of them are administratives) is a challenging task and, by necessity, strengthens all administrative procedures.

The offices at Naya Bazar/Salleri are provided with recent and modem office equipment including PCs. Otherwise it would be impossible to maintain accounts, billing, monitoring and share holder, customer and consumer services, etc. efficiently.

Meter reading and billing are usually time consuming. The project has simplified the procedure as much as possible. With the meterless levels I & 2 (fixed rates) the time spent on meter reading has been minimized. Two operators are able to read the remaining one hundred metered connections (level 3 to 5) within one day.

The operator fills in the meter reading in the customer card as well as in his own log book. The customer confirms the reading with his signature. The customer card is the bill and has to be presented for the payment. The monthly bills have to be paid within the first half of the following month at the payment counter of the company.

Once this procedure had been implemented, timely payment of due bills increased and is

now acceptable.

Reading and billing data are directly entered in the statistical records. This record is an important management tool for the company.

9.2.3 Revenue

As decided by the board of directors of the company, tariffs shall recover the full running costs of the company as well as the depreciation, whereas provisions for the Emergency Fund and Renewal Fund may only be made when the target connection number of 750 connections is realized.

9.3 People's Participation

As already mentioned, SCECO is set up as a public share company. Ad hoc committees have been nominated, representing every "supply area". Contacts, discussions and exchange of ideas are encouraged.

The relations between the company and its customers are very close and open.

Tariff revisions are discussed prior to the decision of the Board and the budget and accounts are accessible to the shareholders. The experiences gained in the tight cooperation with the shareholders show that people do understand that the Salleri Chialsa power plant is 'their own' electricity utility.

10. Conclusions

The installation of small hydro power plants in the geologically and topographically difficult areas of the Himalayas is financially, technically and logistically challenging and feasible; Prior to the transfer of experiences and know how from outside, an assessment

of the local cultural, ethnic and socioeconomic environment must be made;

A close contact to the local population and its representatives avoids m any serious problems; To manage and operate an electricity utility, conceivable regulatory frameworks and guide lines must be strictly applied in day-to-day business. All staff must strictly follow the regulations to create the basis of good cooperation between the customers and the company. Every decision is based on a clear and understandable policy.

Tariff structures must be as simple and transparent as possible and closely related to the real costs and Asks (equipment: reliability, availability..., operation: load management, maintenance... and administrative procedures: meter reading, billing...).

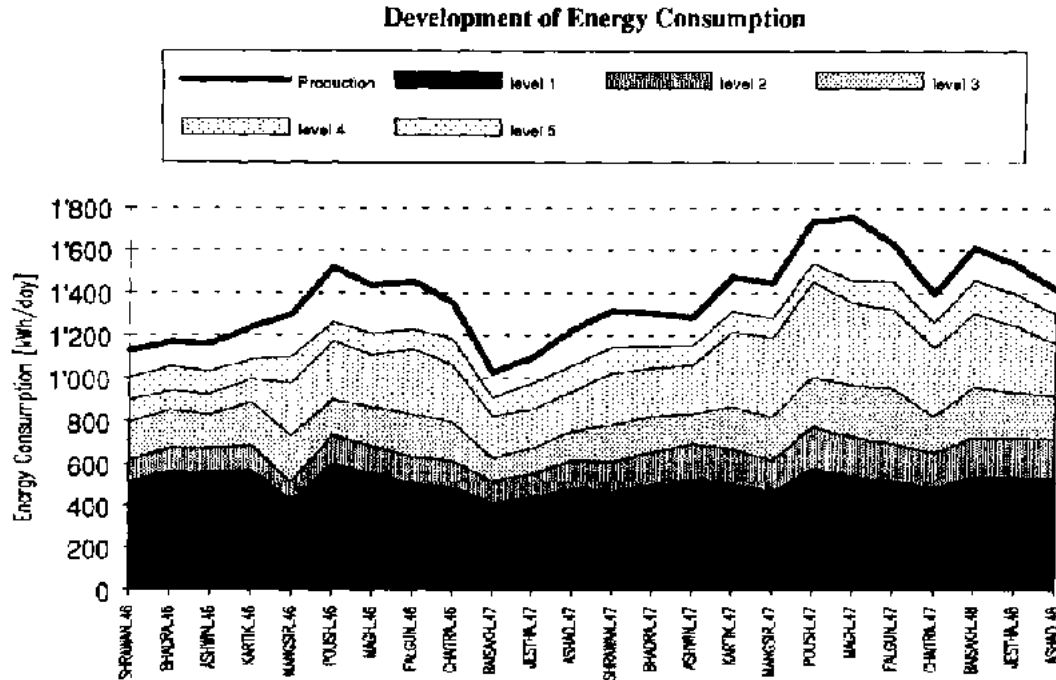

Fig 2 Development of the energy consumption for the different levels 1-5 (Nepal) years mid 2046-48)

Generation Report Salleri Chialsa Electricity Company

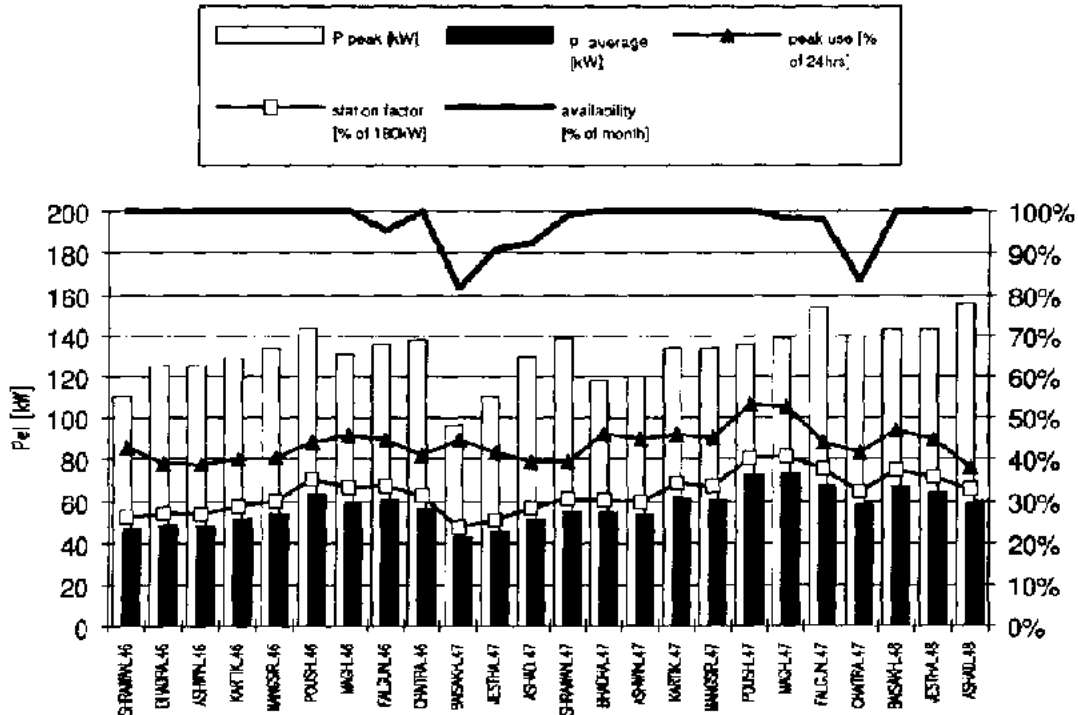

Fig 3 Production figures (Nepal) years mid 2046-48)

MONTH	DAYS	TIME (2)	PRDD	LOSS	INTRA	STR	DISTR	L3 (metered, 2kW)	L4 (metered, 8kW)	L5 (meter, varkW)	L1 (no meter, 100W)	L2 (no meter, 500W)	REV

		[MSE]	[KWH]	[KWH]	[KWH]	[KWH]	[KWH]	#	[KWH]	[MSE]	#	[KWH]	[MSE]	#	[KWH]	[MSE]	#	[KWH]	[MSE]	#	[KWH]	[MSE]	
SHRAWAN_46	32	768	36076	2165	1731	152	32028	37	5541	10124	17	3266	5843	4	3328	2662	115	3306	2727	126	16467	10000	31'
BHADRA_46	31	744	36203	2179	1242	147	32641	38	5341	9808	18	2748	5084	4	3580	2908	116	3532	2711	126	17440	9840	30'
ASHWIN_46	30	720	34850	2090	1600	143	31017	38	4602	8311	18	2921	5622	4	3245	2629	115	3342	2650	128	16907	10080	30'
KARTIK_46	30	720	37169	2230	2243	178	32518	43	6045	10717	18	3204	5159	5	2667	2276	115	3491	2600	124	17111	9500	30'
MANGSIR_46	30	720	38985	2339	3428	178	33040	40	6510	10876	22	7271	10285	5	3787	3635	116	2641	3235	124	12831	14520	42'
POUSH_46	29	696	44052	2643	4604	172	36633	40	4756	9106	25	7668	11276	5	2674	2603	123	3980	3534	118	17355	13920	40'
MAGH_46	29	696	41592	2495	3657	172	35068	41	5256	9767	25	7117	10617	5	2958	2957	128	3775	3596	117	16060	13800	40'
FALGUN_46	30	720	43570	2614	3895	178	36883	41	5871	10109	25	9153	12500	5	2601	2912	131	3846	3813	114	15212	13440	42'
CHAITRA_46	31	744	41979	2519	2635	184	36641	42	5565	10068	26	8260	12086	5	3692	3523	131	3914	3675	112	15210	13320	42'
BAISAKH_47	31	744	31845	1911	1668	147	28119	41	3360	7591	29	6060	10144	5	2624	2769	130	3270	3782	112	12805	13320	37'
JESTHA_47	31	744	34046	2043	1538	158	30307	43	3769	8152	31	5560	9791	5	3763	3682	130	3527	3720	111	13688	13080	38'
ASHAD_47	31	744	38100	2266	2648	158	32808	45	4158	8642	33	5631	10368	5	3778	3693	152	4305	4402	116	14935	13800	40'
SHRAWAN_47	32	768	42183	2531	2781	163	36708	46	5472	10221	33	7621	12328	5	3946	3829	168	4661	4836	119	15003	14040	45'
BHADRA_47	31	744	40456	2427	2257	158	35614	47	5051	9983	33	6965	11700	5	3155	3148	176	4860	5094	124	15563	14640	44'
ASHWIN_47	31	744	39866	2392	1555	158	35761	49	4362	9281	33	6909	11487	5	2946	2970	180	5249	5239	123	16305	14520	43'
KARTIK_47	30	720	44248	2655	1869	191	39513	51	5823	11223	35	10501	15239	5	3020	3021	180	4912	5270	123	15257	14640	49'
MANGSIR_47	29	696	42006	2521	2097	185	37203	53	5936	11404	36	10661	15650	5	2727	2787	183	4511	5394	120	13446	14280	49'
POUSH_47	30	720	52022	3121	2541	191	46169	53	6925	12455	36	13409	18113	5	2580	2630	186	5877	5425	121	17379	14280	52'
MAGH_47	29	696	50847	3051	5352	185	42359	55	6890	12601	36	11225	16014	6	2988	3168	187	5441	5425	119	15737	14040	51'
FALGUN_47	30	720	48820	2929	2102	191	43598	55	7743	13293	36	11141	15990	6	3862	3864	189	5333	5318	121	15519	14280	52'
CHAITRA_47	30	720	41812	2509	1226	191	37887	54	5056	10596	37	9590	14633	6	3614	3764	190	5040	5580	121	14588	14280	48'
BAISAKH_48	31	744	49304	2964	1517	158	45235	55	7200	13117	37	10733	15879	7	4782	4890	191	5905	5549	121	16715	14280	53'
JESTHA_48	31	744	47651	2859	1260	158	43374	57	6516	12282	37	9632	14949	7	4738	4822	190	5810	5487	120	16678	14160	51'
ASHAD_48	32	768	45392	2724	820	163	41685	57	6396	12120	37	7828	13213	7	4476	4594	191	5961	5518	120	17024	14160	49'

Year 48/47	395	8760	458467	27508	31289	1967	397703	41	60877	112871	24	69079	109755	5	38797	36549	125	42929	40596	119	136021	148720	449
Year 47/48	356	8784	545207	32713	25396	2092	485006	53	73261	138576	36	116235	175195	6	42812	43505	184	63460	64325	121	189218	171600	593
total/average	731	17544	1003674	60221	56685	4059	882709	47	134138	251447	30	185334	284950	5	81609	80054	155	106389	105021	120	375239	320320	1041
change			19%	19%	19%	6%	22%	29%	20%	23%	48%	68%	60%	21%	10%	18%	47%	48%	58%	2%	2%	15%	

Month, Days, Time Nepali Month, # of days, # of hours total/average average where applicable
 Proc total generation change relative change between 47/48 and 48/47
 Loss system losses varkW max power consumption is negotiable
 Intr internal consumption
 Str street lights
 Distr total consumer distribution
 L1-5 level 1 - level 5

Table 6 Development of the number of connections, power consumption and energy prices for the different levels 1-5 (Nepal) years mid 204648)

Development of # of Connections

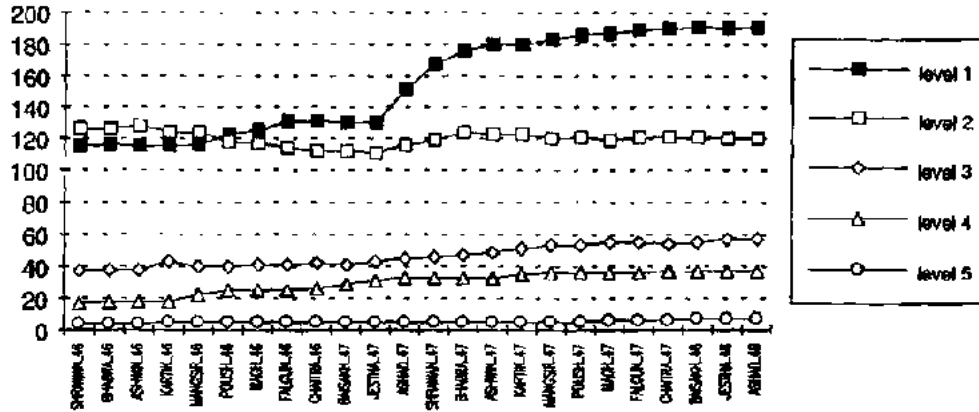

Development of Power Consumption

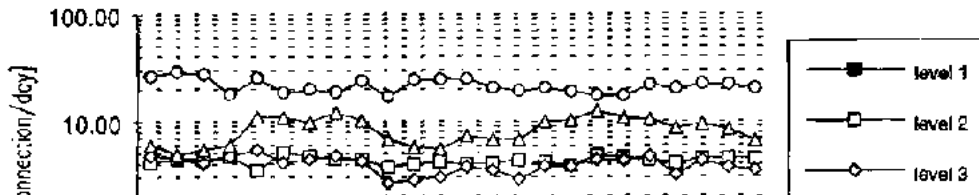

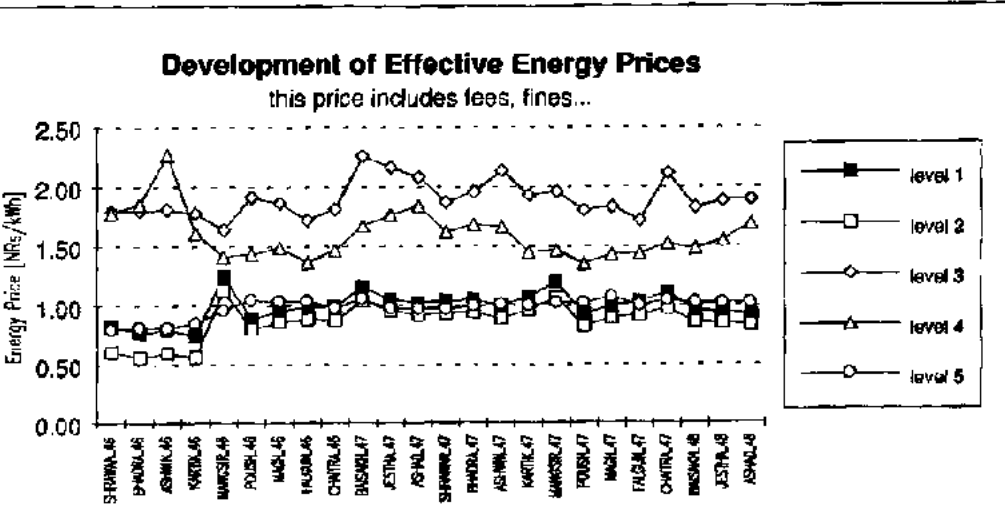
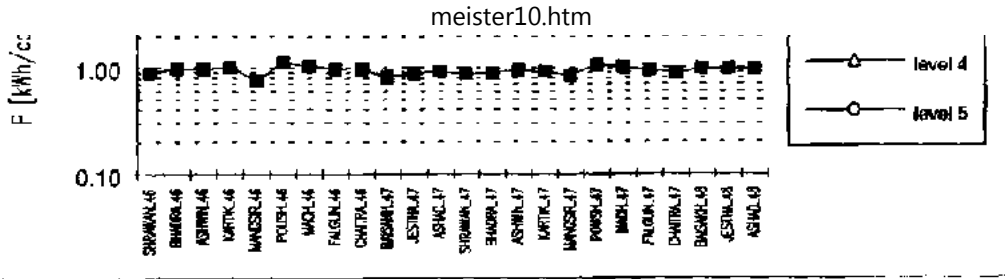

Table 7 Detailed figures for the energy production/consumption (Nepal) years mid 2046-48)

Part 1

BRIDGER, Gordon and J.T. Winpenny

Planning Development Projects: A Practical guide to the Choice and Appraisal of Public Sector Investments, ODA, 1983

**DUNSHEATH,
Percy A History of Electrical Engineering, Faber Editions, 1962**

ELSENHANS, Hartmut and Harald Fuhr International and National Development Administrations, Development Theories, and Small Enterprise in LDC's: An Overview of Current Research, in Administrations and Industrial Development, Elsenhans and Fuhr, eds., National Book Organization, 1991

**KIGGUNDU, Moses N.
Managing Organizations in Developing Countries, Kumanan Press**

**KORTEN, David C.
International Assistance: A Problem Posing as a Solution, IRED-Forum, No. 41, Oct-Dec 1991, p. 71**

**PANOS
Towards Sustainable Development, The Panos Institutc, 1987**

**RONDINELLI, Dennis A.
Development Projects as Policy Experiments: An Adaptive Approach to Development Administration, Methuen, 1983**

**SALAM, Muhammed Abdus
Science, Technology and Science Education in the Development of the South, The Third World Academy of Sciences, May, 1991**

SCOTT, Andrew

Power and People: Aspects of Micro-Hydro in WATERLINES, V10 N2, October, 1991

**SHRESTA, Ram Shrestha and Kiran Man Singh
Improved Ghattas in Nepal in Appropriate Technology, V16 N3 December, 1989**

**SMILLIE, Ian
Mastering the Machine, IT Publications, 1991**

**STARKEY
Perfected Yet Rejected, GTZ/GATE, 1988**

**TURVEY, Ralph, and Dennis Anderson
Electricity Economics: Essays and Case Studies, Johns Hopkins University Press, 1977**

**UNDP/ESCAP/FAO
A New Approach to Energy Planning for Sustainable Rural Development, FAO Environment
and Energy Paper No. 12, FAO, 1990**

**WALTHAM, Mark
Micro-hydro for Rural Energy in Nepal in Appropriate Technology, V 18 N3, Dec. 1991**

Part 2

**BRAZIL, J.,
Dublin Institute of Technology
Development of a stand alone induction generator for low cost micro hydro systems in
Small Hydro 1990, 4th International Conference on Small Hydro, published by Water
Power & Dam Construction**

CHAPALLAZ, J-M.,

Dos Ghali 1., Eichenberger P., Fischer G. Manual on Induction Motors used as Generators, GTZ/GATE, 1992

WIDMER, R.

Product Informahon - Electrical Machines (< 100 kVA), SKAT, 1992

Part 3

SHRESTHA, R.B., Pradham P.M.S.

State of the Art of Small Hydropower Development in Nepal, WEC energy workshop, Kathmandu, Nepal, 1985

EYSBERG, P.

A Feasibility Study on Load Controlfor Micro Hydro Power in Nepal, University of Turente, Netherlands, 1985

EBNER, P.

Electrical Equipment of Mini Hydro Power Plants, UNIDO Workshop on mini hydro power development, Vienna, Austria, 1987

Parts

WILD, J., Peyer Corporalion

Erdungsvademecurn, Dimensionierung und Messen von Erdungsanlagen, Peyer Corporation, Switzerland

Part 6

HOLLAND, H. Farr

Transmission Line Design Manual, A Water Resources Technical Publication, United States Department of the Interior, Water and Power Resources Service Denver, Colorado, 1980

Design Standards, Transmission Structures No. 10, Chapter 3, Distribution and Transmission Line Standard Drawings (2 Volumes), United States Department of the Interior, Bureau of Reclamation, Engineering and Research Centre Denver, Colorado

LEYLAND, B., Leyland Consultants Ltd

A Low Cost Rural Distribution System Using Single Wire Earth Return, Leyland Consultants Ltd, 100 Anzac Ave., Box 1859, Auckland, New Zealand

Part 7

ITDG & Ceylon Electricity Board

MICRO-HYDRO POWER Training Course, Design Guide Part 1, written by the Dept. of Mechanical Engineering, Edinburgh University, edited by Harvey A. and Brown A. for ITDG, Sri Lanka, 1991

Part 8

FINCK, H., Oelen G., GTZ

A Guide to the Financial Evaluation of Investment Projects in Energy Supply, GTZ Eschborn BRD 1985, Schrirenreihe GTZ, No. 163

GOWEN, Marcia M., Wade Herben A.

Renewable Energy Assessments, An Energy Planner's Manual, Pacific Island Program/ Resource Systems Institute, East West Centre, Honolulu, Hawaii, USA 1985,

Part 9

ITECO

SELUP 11, Salleri Electricity Utilization Project. The Salleri Chialsa venture in Nepal, an article for SKAT by ITECO AG Affoltern, Switzerland, 1991

Part 10

VAIDYA, S.L., BYS

Governing/Electrical Control, Protection and Instrumentation, Report for SKAT, 1989

OETTLI, B., BYS

Namche Bazar MHP, the Supplier's Final Report, BYS, Kathmandu

OETTLI, B., BYS

Establishing BYS in the Small Hydro Business, BYS, Kathmandu

BYS Syangja MHP, Manual for Operation, Maintenance & Trouble Shooting, BYS, Kathmandu

BYS Chame MHP, Manual for Operation, Maintenance & Trouble Shooting, BYS, Kathmandu

Part 11

ITECO

SELUP 11, Salleri Electricity Utilization Project. The Salleri Chialsa venture in Nepal, an article for SKAT by ITECO AG, Affoltem, Switzerland, 1991

ABBREVIATIONS AND GLOSSARY

AC

Altemating Current

ACSR
Aluminum Conductor, Steel Reinforced

Al
Aluminum

APFC
Automatic Power Factor Correction

BYS
Balaju Yantra Shala (p) Ltd, mechanical workshop, Kathmandu, Nepal

C
Capacitor
Cu
Copper

DC
Direct Current depreciation

In accounting: an allowance for the fact that fixed assets (plant and machinery) wear out or become obsolete

discounting reduction in the value of a future payment calculated at a given interest (discount) rate to establish its present value discounting factor

factor for calculating the present value of a single future payment accounting for the time and a given interest (discount) rate

FAO

United Nations Food and Agricultural Organization

HBC

(fuse) High Breaking Capacity

HMG

His Majesty's Government

HV, HT

High Voltage, High Tension

internal; external financing provision of finance within a company to permit the adoption of an investment ;securing of financial resources from outside a company to meet capital requirements

ITDG

Intermediate Technology Development Group

ITECO

Company for International Technical Cooperation and Dcvelopment of Switzerland

L

Inductance

LV, LT

Low Voltage, Low Tension market interest rate the commercial interest rate prevailing in capital markets

MHPG

Mini Hydro Power Group

pf
Power Factor

PLC
Programmable Logic Controller

SATA
Swiss Association for Technical Assistance, today SDC/ Helvetas

SCECO
Salleri Chialsa Electricity Company Ltd.

SDC
Swiss Development Cooperation

SELUP
Salleri-Chialsa Electrification and Utilisation Project service life period during which an investment facility will be used up economically. The service life can be shorter than the technical life, however, they are usually assumed to be equal.

SHDP
Small Hydel Development Board, Ministry of Water Resources & Power

SHP, MHP, PHP
small, micro and pico hydro power which is defined by the power (approx. 100-1 000, 10-100 and 1-10 kW respectively).

SKAT
Swiss Centre for Development Cooperation in Technology and Management
technical life maximum period during which plants or components can be technically

operational**Unesco****United Nations Educational Scientific and Cultural Organisation.****X****Reactance****Z****Impedance**

Electrification is no longer an engineering or technical problem. This part of the job has been solved all over the world a thousand times throughout the last hundred years and can now be adapted as needed. Electrification is a development of a society/community; using electricity is a way of life and needs adjustments of the people. They must be ready and open to learn and participate, have confidence and commitment.

Available electrical energy offers potentials for growth. For instance rural electrification can complement and transform rural economies. Successful rural electrification, however, is more likely in areas with at least moderate economic activity, there is little evidence to suggest that rural electrification in itself can initiate economic activity.

This book, although rather technical, tries to keep this in mind. In its first part it identifies the 'Energy Entrepreneurs' and 'Machine Makers' as the key to using market mechanisms to promote rural electrification in developing countries.

The following parts list in different articles some technical aspects of electrification. The technical descriptions follow the energy flow through the electrification scheme, starting with the generator and ending with the distribution system at the consumers' connection. It is assumed that the energy source and the primemover are chosen. This might be a MHP

(Micro Hydro Power) system, and we will mostly refer to this option, but also a diesel engine or a solar or wind "farm" or simply a link to an already existing power grid is possible.

The next parts discuss commercial, financial and legal aspects emphasizing order and tender procedures, developing tariff structures and defining legal terms for a connection policy respectively.

Finally some weight is given to experiences gained in Nepal with electrification projects. The 'Salleri Chialsa Venture' is described detailed with emphasis on the legal setup of the SCECO, the Salleri Chialsa Electricity Company.



[Home](#) > [ar](#) [cn](#) [de](#) [en](#) [es](#) [fr](#) [id](#) [it](#) [ph](#) [po](#) [ru](#) [sw](#)

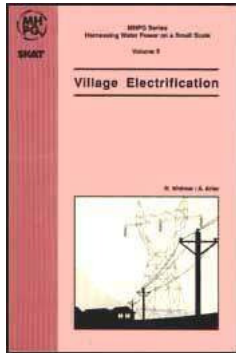

Village Electrification (SKAT, 1992, 128 p.)

 [\(introduction...\)](#)

  [The foreword](#)

 [Acknowledgment](#)

 [Introduction](#)

[Part 1: Determined entrepreneurs, sustainable development](#)

[Part 2: Generators](#)

[Part 3: Electrical control systems](#)

[Part 4: Power factor correction](#)

[Part 5: Earthing](#)

[Part 6: Distribution systems](#)

- Part 7: Commercial engineering**
- Part 8: Tariffs & financial evaluation**
- Part 9: Connection policy**
- Part 10: Typical application examples**
- Part 11: The salleri chialsa venture**

The foreword

It is hardly necessary to stress the important role electricity can play in a society. The matter of deciding on what ground electricity should be made available to areas not yet electrified has been argued at great length - mainly by people who enjoy a regular supply of affordable electricity already.

Reasons to furnish remotely located villages, lacking any sign of a bustling economy, with electricity can be found - the same holds true for the opposite.

Village electrification, the topic of this book, is basically a political issue, even though the problems may seem essentially technical.

As a result, there would be little justification for another book on the subject were it not for the fact that many of the works that have appeared in recent years have been overdeveloped along certain lines and have not been generally useful to those involved in the implementation of village electrification programs.

However, the true merit of this book may be that the authors have experienced countless candle light dinners attempting to contribute to village electrification.



[Home](#)"" """"> [ar.cn.de.en.es.fr.id.it.ph.po.ru.sw](#)



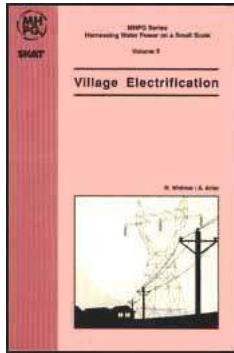

Village Electrification (SKAT, 1992, 128 p.)

 **(introduction...)**

 **The foreword**

  **Acknowledgment**

 **Introduction**

Part 1: Determined entrepreneurs, sustainable development

Part 2: Generators

Part 3: Electrical control systems

Part 4: Power factor correction

Part 5: Earthing

Part 6: Distribution systems

Part 7: Commercial engineering

Part 8: Tariffs & financial evaluation

Part 9: Connection policy

Part 10: Typical application examples

Part 11: The salleri chialsa venture

Acknowledgment

This book is the result of the collaboration and contributions of several authors and organizations. Publication has been financed by the Directorate for Development Cooperation and Humanitarian Aid of the Government of Switzerland (DEH/ SDC). Our sincere thanks go to J. Grierson, B. Leyland, B. Oettli, H.P. Prinz, J. Senn, S.L. Vaidya, N. Neuhaus, A. Harvey, A. Brown who have contributed articles, to S. Ndiaye for the proofreading and to W. Fuchs who made the final layout and was responsible for having the book printed.

First edition: 1992 by SKAT, Swiss Centre for Development Cooperation in Technology and Management

Authors: Rolf Widmer and Alex Arter, SKAT

Published by: SKAT, Swiss Centre for Development Cooperation in Technology and Management

Layout: Rolf Widrner Wemer Fuchs, SKAT

Cover: F. Hartmann, ASG, St. Gallen, Switzerland

Copyright: SKAT

**Comments: Please send any comments concerning this publication to: SKAT
Tigerbergstrasse 2 CH-9000 St. Gallen, Switzerland**

Printed by: Niedermann AG, St.Gallen, Switzerland

ISBN: 3-90XOOI - 1 5-3

MHPG, the Mini Hydro Power Group is an international network constituted by GTZ-GATE, Germany, FAKT, Germany, IT, U.K., PPL, Germany, Projekt-Consult, Germany, and SKAT, Switzerland.

The MHPG is one of the most expert and experienced group concerned with hydro work. It can give advice in the field of both small and large projects. The member organizations have a long-term experience in fruitful collaboration in the field of micro and mini-hydro projects.

Further information is available at SKAT or one of the other members of the group.



[Home](#) > [ar.cn.de.en.es.fr.id.it.ph.po.ru.sw](#)

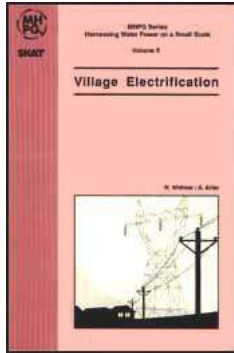

Village Electrification (SKAT, 1992, 128 p.)

 [\(introduction...\)](#)

 [The foreword](#)

 [Acknowledgment](#)

  [Introduction](#)

[Part 1: Determined entrepreneurs, sustainable development](#)

[Part 2: Generators](#)

[Part 3: Electrical control systems](#)

[Part 4: Power factor correction](#)

[Part 5: Earthing](#)

[Part 6: Distribution systems](#)

[Part 7: Commercial engineering](#)

[Part 8: Tariffs & financial evaluation](#)

[Part 9: Connection policy](#)

[Part 10: Typical application examples](#)

[Part 11: The salleri chialsa venture](#)

Introduction

Electrification is no longer an engineering or technical problem. This part of the job has been solved all over the world a thousand times throughout the last hundred years and can be adapted as needed. Electrification is a development of a society/community; using

electricity is a way of life and needs adjustments of the people. They must be ready and open to learn and participate, have confidence and commitment.

Available electrical energy offers potentials for growth. For instance rural electrification can complement and transform rural economies. Successful rural electrification, however, is more likely in areas with at least moderate economic activity, there is little evidence to suggest that rural electrification in itself can initiate economic activity.

Besides the potentials for improvement and growth there are also risks, for instance electricity is not readily available for everybody. It needs considerable infrastructure, know how, technology... also planning, finances and political will. This energy is concentrated and accessible only in a well organized manner. What a difference compared to, say, gathering fire wood!

Being based on such a large necessity for control, electrical energy might stabilize hierarchies and confirm political power structures, as it needs authority to protect installations, to enforce rules and regulations (the law) and it needs elites and specialists (politicians, technicians, investors etc.). In many developing countries electricity is a privilege and often for the cities only.

The introduction of electricity in the energy variety of a village is the decision to tap a versatile energy resource driven by or to drive the social and economic evolution of the village society.

This book, although rather technical, tries to keep this in mind. In its first part it identifies the 'Energy Entrepreneurs' and 'Machine Makers' as the key to using market mechanisms to promote rural electrification in developing countries. They need to be supported and encouraged. In practice this means using planning models and regulatory frameworks that coopt their development potential and direct assistance to enhancing their local technological capacities. They need local technological capacity to make informed

decisions about demand, investment, and technology selection and adaptation, and to manage the implementation of these decisions. Developing sustainable village electrification ultimately means developing these capacities.

The following parts (part 2: to 6:) list in different articles some technical aspects of an electrification. The technical descriptions follow the energy flow through the electrification scheme, starting with the generator and ending with the distribution system at the consumers' connection. It is assumed that the energy source and the primemover are chosen. This might be a MHP (Micro Hydro Power) system, and we will mostly refer to this option, but also a diesel engine or a solar or wind "farm" or simply a link to an already existing power grid is possible. There are standard solutions like synchronous generator with automatic voltage control, hydraulic governor, transformation for three phase high tension distribution and step-down transformers at the consumers, all this is readily available. We will discuss in some more details alternatives (using for instance asynchronous generators and single wire distributions) to show, how costs could be reduced by engineering and at what risks.

The next three parts (part 7: to 9:) discuss commercial, financial and legal aspects emphasizing order and tender procedures, developing tariff structures and defining legal terms for a connection policy respectively.

Finally some weight is given to experiences gained in Nepal with electrification projects. The last two parts (part 10: to 11:) are electrification examples in remote areas of the Himalayas. Briefly the key data of the powerplants installed in the villages of Namche Bazar, Chame and Syangja are given. The 'Salleri Chialsa Venture' is described detailed with emphasis in the legal setup of the SCECO, the Salleri Chialsa Electricity Company.



[Home](#)"" """"> [ar.cn.de.en.es.fr.id.it.ph.po.ru.sw](#)

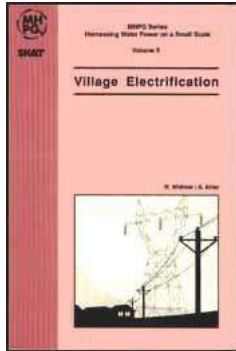

Village Electrification (SKAT, 1992, 128 p.)

➔ Part 1: Determined entrepreneurs, sustainable development

 (introduction...)

 1. Planning for private sector involvement

 2. A very brief history of electrification

 3. A look at current events

 4. Aspects of successful rural electrification

Village Electrification (SKAT, 1992, 128 p.)

Part 1: Determined entrepreneurs, sustainable development

John P. GRIERSON, Swiss Centre for Development Cooperation in Technology and Management (SKAT), St. Gallen, Switzerland

1. Planning for private sector involvement

The challenge of planning for and providing village electrification has not been satisfactorily met. In developing countries all aspects of rural life from food processing to factories, from enterprise to entertainment, suffer from the lack of available, reliable electricity. Though modest progress has been made there is but little evidence of well established, sustainable systems serving rural areas. All too often 'successful' village electrification is based upon political priorities that justify subsidies - and provide exemptions from the demanding economic, ecological and social criteria of sustainable development.

Even in these cases 'successful' has seldom meant long term, much less sustainable. Following the normal pattern most rural electrification schemes have ceased operations within a few years of handover. Far from demonstrating sustainable development most have failed to demonstrate even institutional and operational sustainability much beyond the period of official sponsorship and technical assistance. Subsequent analysis reveals the following causes:

- 1) Mismatch between plant capacity and energy demand;**
- 2) Inappropriate equipment;**
- 3) Lack of trained personnel;**
- 4) No provision for repair and maintenance;**
- 5) Failure to identify the local energy market; and**
- 6) Limited private sector involvement.**

The response of the development community and national electricity authorities has been to: 1) Emphasize plant rehabilitation; 2) Address rural electrification needs by expanding the national high tension grid; and 3) Encourage private sector involvement in all aspects of generation, transmission and delivery. These trends have evolved within a larger context of increasing environmental concern, emphasis on sustainable development, and pressure to use renewable energy resources. Thus, while the role of the market is increasingly recognized, this is often accompanied by pressure to use economically less viable renewable energy options, and by the need to operate within the complex parameters of "sustainable rural development". There has been, on the one hand, a shift in thinking away from addressing the challenge of village electrification with centrally planned, and state supplied and selected technologies and towards that of bringing market forces to bear on the problem. However, there is a counterbalancing trend towards elaborate interventionist planning models, ostensibly in the interests of ensuring sustainable development.

Paradoxically, the sustainable development concept which should logically encourage the development of local capacity, local contribution and local accountability may result in the reverse. The sustainable development concept is in danger of becoming a new justification for centrally administered and directed comprehensive energy planning. There is an emerging approach to sustainable energy planning being mooted which offers much rhetoric in favour of "decentralization" and "micro-level" while in reality retaining all the classic elements of central administration and control. This approach is exemplified by the new 1990 United Nations Food and Agricultural Organization's (FAO) "Environment and Energy Paper".

'The central feature of the new approach is the preparation and implementation of area-based decentralized energy plans for meeting energy needs for subsistence and development at the least cost to the economy and the environment, and linking the micro-level plans with national economic planning and development programmes, including those for the energy, agriculture and rural development sectors.'

**'A New Approach to Energy Planning for Sustainable Rural Development',p. 5,
FAO/ESCAP/UNDP, 1990**

The 'newness' is for the most part reflected in the proposed concentration of bureaucratic resources on the demand determination and regulatory roles, and on the degree of attention (and resources) given to 'comprehensive integrated rural energy planning'. While in principal supporting a greater role for market mechanisms the FAO proposal dismisses previous attempts to reach the 'market potential in rural areas' as 'dismal failures' due to 'lack of proper local assessment and planning and linkages with rural development programmes'. The FAO finds that the market's weakness - and implied unsuitability - results from its lack of bureaucratic guidance and linkages. The remedy proposed is to expand the plan formulation and intervention processes. Sustainable development is offered as the new

justification for this old and ailing practice.

The view that all-pervasive integrated planning is a development requisite will surely be faced with many challenges from the ranks of the development administrators. It is no less important for rural energy planners and practitioners to add their voice to the chorus if rural electrification is not to lose another development decade.

Certainly there is a need for rural energy evolution within the context of local, national, even regional planning. Just as certainly the massive - and scarce - manpower, organizational and software resources consumed during a comprehensive planning process, cannot be justified if replicability and sustainability are among the evaluation criteria. There is certainly some question whether a comprehensive needs-determination approach would be effective even if the planning resources were commonly and economically available. There are many voices arguing against overly ambitious planning models. To cite but one summary of views:

'This trend towards more sophisticated analysis and detailed planning for rural development ... "leads away from reality, from what is feasible, ... and encourages the design of ideal models which are not only unattainable but also liable to impair rather than improve performance".

This tendency on the part of planners to be unrealistic and impractical is further compounded, in the case of electricity planning, by a frequent tendency to be wrong: 'Major difficulties arise in the extension of service to low income areas in villages ... on account of low economies of scale and low density of demand. There is, however, a tendency to understate the extent and growth of demand ... '. The argument made here is not against the planning process. On the contrary, the argument is in favour of planning models that recognize market realities and incorporate market strengths.

Electrification planning, and particularly the regulatory framework which follows and which gives authority to plans, has all too often served to obstruct rather than promote progress. This is not a new phenomena, but one that is becoming more visible and important as the responsibility for aspects of delivery is increasingly passed to the market. The challenge facing rural electrification practitioners and planners - is to structure the planning process to encourage market participation. To do otherwise is to squander a sustainable local resource, and to ignore the lessons of 100 years of electrification history.

2. A very brief history of electrification

The early history of successful electrification is largely one of determined entrepreneurs identifying local needs (often in urban areas) and creating or adapting technology to supply those needs. Electricity supply to the public started in 1858 in the United Kingdom, and thereafter spread quickly throughout Europe and to the United States. The early history is the story of entrepreneurs famous and obscure: Gramme, Wallace, Edison, Siemens, Ferranti, and a host of others. All were designing and adapting technology - machines - all were responding to a perceived, if not comprehensively analyzed, demand. All were supported by readily available local light engineering capacity. Still famous manufacturers such as Siemens supplied the basic machinery which was subsequently modified and adapted by many obscure and unsung engineers - and non-engineers in small garages and dingy workshops.

In 1883 an enterprise was started in the West End of London which, though originally intended as a local private lighting installation, ultimately developed into a public electricity supply of great technical and engineering interest. The Grosvenor Gallery Company gave such satisfaction that requests for supply increased dramatically. Soon demand exceeded technical capacity to supply and a young engineer, Ferranti, was called in. His modifications and additions to the existing Siemens technology soon resulted in a rapidly expanding and technically manageable supply of wide public interest. The

entrepreneurs, hand-in-hand with the engineers, soon expanded on the Grosvenor Gallery success story. Arc lamps in series followed; Edison refined and marketed the transmission technology for 'feeders' and 'mains'; gas lighting came under increasing pressure due to innovations in electricity supply; the Holbom Viaduct became the first public steam power station in the world; Messrs. Siemens Bros & Co. achieved another first with a hydro-electric station at Godalming on the River Wey.

The early evolution of electrification was driven by determined, if often thought irrational, entrepreneurs. Their demand-analysis was far from comprehensive and often, as today, no doubt wrong. It did, however, prove sufficient to inspire their determination and to identify the eventual direction of success, and it did prove flexible. The early energy entrepreneurs were often engineers and even when not they always had engineering support - local technological capacity - available. They were not, at the outset, guided by plans nor obstructed by regulations. They did not have to bear the administrative costs and bureaucratic burdens that inevitably follow the planning process. They had many advantages that the budding energy entrepreneurs of today would envy.

To be sure the early energy entrepreneurs did not long enjoy the unfettered freedom to follow markets with innovative, adaptive technology. The imposition of restrictive legislation, followed by an immediate reduction in investment in the electricity industry, appears early in the history of electrification. In the United Kingdom a Parliamentary Select Committee began deliberations in 1879 'and heard evidence from many eminent scientists and engineers (who) expressed the hope that there would be no restrictive legislation which would in any way interfere with development.'. The Select Committee agreed and made their recommendations accordingly, but 'in 1882, just when large sums were being poured into the newly formed companies ... the first Electric Lighting Act was passed which proved to be a serious deterrent to development. Two years after passing the Act a hundred and twenty applications had been made and seventy three granted, but not one case existed of the supply of electricity having been commenced. A well-

intentioned plan brought progress to a halt. Soon, to be sure, the influence of science and enterprise was brought to bear, the act was eventually amended, and private investors, innovative engineers and determined entrepreneurs once again got on with the process of electrification. And this process has been repeated in endless cycles in every country since.

3. A look at current events

In spite of an incremental shift in favour of markets, entrepreneurs and innovation the current phase of the innovation-regulation cycle still finds the engineers and entrepreneurs on the defensive. In developing countries they do not yet have a firm enterprise base nor strong technical capacity. The early electricity engineering firms and enterprises had established a foothold; had tested modified and refined technologies; and had found and responded to market niches, before they faced the challenges of bureaucracy. Their struggle was to keep the market viable. Today's entrepreneurs are struggling just to be allowed to test the markets' viability. The challenge 100 years ago was to prevent barriers being erected. The challenge today is to bring them down and to replace them with structures meant to incorporate not constrain market forces. Small victories are much celebrated. The current energy development literature awards accolades for the most modest progress:

'In Nepal ... improved mills are being used to generate electricity ... at 27 percent per installed kilowatt of the capital cost of government-run larger hydro plants. The government has greatly assisted the spread of mill innovation by licensing the private sale of electricity ... '.

Ganesh Ram Shrestha and Kiran Man Singh, 'Improved Ghattas in Nepal', Appropriate Technology, December, 1989

Licensing- which is to say allowing, permitting. Permitting, under still restrictive

conditions, a practice forbidden in law and fact prior to this celebrated 'new' approach to energy planning. In a country with a GNP of perhaps \$150.00, where the national grid reaches perhaps 5% of the rural population, and with one of lowest life expectancies in the world it is thought to be significant progress that national planning authorities now present only a considerable bureaucratic barrier-to-entry (with all the attendance costs, informal and formal that this implies in south Asia) rather than an outright ban. This, to emphasize the obvious, is a barrier-to-entry restraining private initiative from attempting to bring to some of the worlds' remotest, poorest, most environmentally stressed and disease burdened areas a renewable energy resource that might:

'Save the cost of traditional sources of heating and light, such as firewood, dung and kerosene help the development of local industry ... revolutionize social life in the evenings, and has even been invoked as a means of population control ... its effects on education are potentially very strong. Certainly the advantages of electrification are easily seen by comparing those villages with, and those without, power,'

G. A. Bridger and J. T. Winpenny, Planning Development Projects, p. 79, ODA, 1983

Progress to date notwithstanding the pendulum still has far to swing in favour of innovation and enterprise if the market is to offer even a small portion of its potential contribution. Progress is evident; in entrepreneurial innovation and evolution as well as in bureaucratic barrier reduction. Shresta and Singh go on to note that the government of Nepal offered private licensees 'subsidies and credit'. And in the years since, that approach, though not without its criticisms, is thought to have worked. Surprisingly, the criticisms do little to question the wisdom of a poverty stricken nation erecting expensive barriers to entry and then, again expensively, subsidizing those who manage to penetrate them. Notwithstanding this oddity, there are success stories. In Nepal there are now at least ten schemes that supply electricity full time and dozens of schemes producing electricity in the evenings. Privatization seems to be working; the government increased

its level of subsidy fourfold in 1991 to acknowledge this, and there is talk of expanding private licensing as part of a massive planned project to achieve national village electrification. There are now nine independent Nepali companies specializing in building and installing micro-hydro plants. Local technological capacity has been enhanced to the point where it can respond to current levels of local demand. There is evidence of development in that much of the local demand for rural electricity is being supplied by local enterprise, itself underpinned by local technological capacity. The market, though much manipulated, is at least keeping up with innovation in rural electrification technology. The signs of sustainability are encouraging.

At least they were until recently. Planning enthusiasm is threatening to arrest the swing of the pendulum. All too predictably there is a proposal being considered to expand 'privatized' electricity on a massive scale. The means proposed for this are donor funded subsidies and externally supplied development projects - a comprehensively planned 'private sector' electrification project. There is more than a little concern about the effect this will have on rural energy development and local energy entrepreneurs:

'Instead of being a business opportunity to the nine Nepali companies ... this project threatens to destroy them ... by importing equipment offered as "aid". This poisoned pill may ... lead to disaster. Being unable to compete with "free" foreign machines the Nepali micro-hydro industry will wither away taking with it the expertise needed to maintain and repair the equipment. Only if NGOs and donor governments act responsibly will Nepal's micro-hydro industry grow, build up a skilled work force, and offer a sustainable solution to the energy shortage (emphasis added).'

Mark Waltham, 'Micro-hydro for Rural Energy in Nepal', Intermediate Technology, December, 1991

A planning success that for all its defects can be credited with creating a 'local

technological capacity' in rural electrification is now feared, within a very short cycle of two years, to become the instrument of that technological capacity's extinction.

The mistake is not so much the planning process itself, but in the almost inevitable tendency of such processes to constrain rather than encourage markets and entrepreneurs. In Nepal, as in many other places, the planning approach is demonstrating sadly little comprehension of the workings of the market mechanisms they so fervently pledge to support.

In an era of increasing concern for sustainable development the inevitability of 'plans' must be accepted. Yet, it does not follow from this that plans must inevitably fail to stimulate and encourage the local technological capacity and local entrepreneurs that offer the best hope for rural energy sustainability. A good plan can and should provide a development framework that co-opts market efficiencies and allocates resources to enhancing market based local capacity. This can extend to allowing the market to function largely unfettered - to remove barriers to entry and direct scarce administrative resources to more productive tasks. Successful examples abound; one need look no further than Alaska, the largest and one of the richest of the 50 American States, to find rural electricity being supplied commercially by small local entrepreneurs. The capacity to create, virtually cost free, such possibilities is an opportunity developing countries have largely declined to exploit.

The history of electrification, from early European events to current Asian, African and even Alaskan anecdotes, offers many lessons that can be applied to planning for sustainable village electrification.

4. Aspects of successful rural electrification

4.1 Sustainability

The first and foremost lesson is a modern one: that rural electrification is very much a matter of sustainable rural development. There can be little argument that sustainable village electrification belongs well within the parameters of the sustainable development concept. Accepting this means accepting that village electrification must take place within, and largely subject to, a complicated process of planning and regulation. This will certainly constrain the ability of the market to respond, much to the chagrin of those who maintain that the market is always the best answer. More to the point it challenges those involved in village electrification to use the planning process to identify and enhance market strengths and recognize market weaknesses while planning for both within the larger context of sustainable development.

4.2 Growth or Development?

The second lesson is that development is the goal and that growth alone is not an acceptable substitute.

'Growth alone can be achieved with other people's money, labour, management and technology. Development of a nation's capacity to use its own resources to meet its own needs is another matter. This reality is illustrated by the oil producing countries of the Middle East that have achieved spectacular growth by selling off a non-renewable resource, but depend on others for everything, from managers and engineers to labourers. Only by the most narrow definition could one maintain that they are "developed"'

David C. Korten, 'International Assistance: A Problem Posing as a Solution', IRED-Forum, No. 41, Oct-Dec 1991, p. 71

Development, summarizing Korten is 'a nation's capacity to use its own resources to meet its own needs'. The process of development necessarily means enhancing this capacity.

4.3 Local Technological Capacity

A national energy policy which includes village electrification will need to be supported by efforts to enhance the 'local technological capacity' in demand assessment, power generation and transmission, tariff determination, and management. Often, and especially in the case of off-grid rural facilities, the energy plan should allow for, and if necessary help develop, the required local technological capacities of local entrepreneurs. Those charged with supply responsibilities, utilities as well energy entrepreneurs, need the local technological capacity to continuously assess demand and respond accordingly. However, while planning and management capacities are important, local engineering capacity is paramount.

Enhancing critical local technological capacities is the key to village electrification within the context of sustainable development. The most important is the capacity to assess, select, absorb, modify and eventually create technology - to be masters of the necessary machines. Technology cannot merely be 'consumed' in the interests of growth, it must be absorbed locally and mastered in the interests of development. It is this capacity to absorb, to manipulate, modify, and eventually replace with local innovation that no nation can hope to develop without. The process cannot be substituted for in critical technologies, nor can it be sub-divided and delegated. Half-a-loaf will never be enough. Assessment and selection cannot be delegated to a foreign agency or a national planning authority with absorption being left to local manufacturers and users. This lesson is not unique to rural electrification. Paul Starkey, in assessing agricultural implement development, found that one of the 'fundamental lessons' was: 'the dangers of aid agencies, international centres and national programmes using their considerable influence and resources to promote ...inadequately evaluated technologies.' Inadequately evaluated by the users, those who must absorb them; in this case the manufacturers, maintenance agencies, utilities and energy entrepreneurs involved in rural electrification.

'Experience from many organizations has led to the conclusion that, if an organization or country does not have the capacity to operate, maintain, and service a new technology

package, it should not acquire it no matter how attractive it might be.' These is precisely the danger threatening the micro-hydro industry in Nepal. The planners, responsible for selection, have found a new technology package that the users can neither absorb nor compete with. A mistake such as this cannot be made if the planning process placed technology assessment, selection and absorption decision responsibility much closer to where it belongs, with the mill owners and manufacturers who must absorb the technology. Sustainable village electrification means, in the first instance, that local industrial markets and manufacturers machine makers - must have the collective skills for technology absorption and creation. No planning model can substitute for parts of this process. A good planning model will upgrade system capability by directing assistance to enhancing the local technological capacity of the entrepreneurs struggling to master the machinery of rural electrification.

4.4 Mastering the Machine

Mastering the Machine is the title of Ian Smillie's lively history of Appropriate Technology. The title itself, in three short words, describes the only possible short-cut to sustainable national development in any hard technology. Mastering the machine means developing the engineering ability to modify and create technology, to go beyond producing parts and to begin producing machines. And to build machines based not on trial-and-error or luck but on an understanding of technology and science. 'Very late starters' is one of many terms used to describe those nations who have yet to make much progress in self-sustaining industrialization. Most are in Africa, and unlike Asia and Latin America, most have an extremely weak light engineering sector. Few countries in Africa have even adequate local technological capacity in machine engineering. Few developing countries have any expectation of reaching most villages with the national grid. Local technological capacity must be able to address problems such as this. But what precisely are the Local Technological Capacities that must be enhanced if machines are to mastered?

No less a figure than the Nobel Prize winner, Muhammed Abdus Salam has pondered the problem.

'One should say it clearly and emphatically that classical Low Technology is like Basic Sciences it must be developed by any nation wishing to industrialize - particularly the design and fabrication part of it.' There are five sub-areas of 'Classic Low Technology: (1) Bulk Chemicals; (2) Iron, Steel and Other Metals Fabrication; (3) Design and Fabrication in Indigenous Industries; (4) Petroleum Technologies; and (5) Power Generation and Transmission ... Here no new scientific principles remain to be discovered.

However, developmental work relating to design adaptation and modification is important. Thoroughness (in all aspects in manufacture and after-services) ... design ... quality ... cost ... competitiveness ... are all-important. These are just the areas where developing countries should NOT be deficient - though, unfortunately, they are.

They are the principal areas of Local Technological Capacity that should be enhanced if energy entrepreneurs are to master the machines of village electrification.

4.5 Machine Makers: The Role of Engineering Enterprise

Clearly, a problem that has in the very recent past been overwhelmingly addressed by plan-led solutions is struggling to come to terms with alternative or modified approaches. While not being encouraged by some sense that the state-of-the-art has progressed no further than the FAO proposal, there are encouraging signs emerging elsewhere. Moses Kiggundu, looking at the organizational ownership aspects of the technology transfer process and the extent to which they facilitate or prohibit the development of local technological capacities and effective utilization of technology assessed several studies from Africa and elsewhere. He found that the 'results seem to suggest that the indigenous private sector may have a more important role to play in promoting effective transfer of technology and developing the local technological capacity than has been realized by most

developing countries. ""

The lesson for rural energy planning is that the private sector and very specifically the private machine manufacturing light engineering sector, is a key actor in the complex process of rural electrification. Learning this lesson involves no more than rediscovering the past. Early electrification was certainly a local, community based phenomena - one almost exclusively dependent upon determined private machine modifiers and manufacturers. Local entrepreneurs underpinned by local engineering enterprises were, collectively, the growth engine of early electrification. This lesson needs to be coopted a thousandfold into village electrification projects world-wide.

The goal is not merely to incorporate the economic efficiency of locally based resources, skills and initiative in the interests of growth. The goal is development - mastering machines, creating, along with rural electrical facilities, local technological capacity to search for, choose, modify and eventually develop locally appropriate technologies. The recognition of the importance of this is part and parcel of recognizing the necessary contribution of the machine makers - and understanding the contribution of the market to sustainability.

'The short-term advantage of being able to produce with imported technology may turn out to be a long term disadvantage due to continuing incapacity to create one's own equipment. There is no doubt that the capacity to repair, copy, improve and redesign a machine is greatly increased if there are mechanical workshops. The most efficient training centre is a machinery producing factory, even if its products are not yet as sophisticated as the imported machinery.

Again, the stress is on developing local technological capacity, very specifically that local technological capacity found in the light engineering machine making sector.

Collectively these lessons identify a specific focus for the needed capacities, and indicate

the nature of the needed capacities themselves. The focus is energy entrepreneurs - the machine manufacturers. The capacities include demand determination, machine making skills and the managerial skills to combine these capacities profitably.

The overlapping modern histories of appropriate technology and enterprise promotion reveal the need for a cautionary word. Technology evolution is a complicated and challenging process as is enterprise creation. Ian Smillie wisely warns that 'great caution must be exercised in mixing enterprise creation and new technologies ... fragile vehicles can carry only so much freight ... a project that is overloaded with too many objectives is more likely to fail than one with limited objectives.' The danger is much greater when technology is being transferred in rather than evolved locally. Established light engineering firms are more likely to successfully absorb the ability to assess, select and modify technology, and to make new machines, than newly created enterprises. Energy utilities and entrepreneurs supported by established local engineering capacity in energy equipment manufacture and maintenance are more likely to succeed than those simply 'consuming' imported technologies that are unsupported locally. This caution reinforces the essential lesson: local energy utilities and entrepreneurs are best supported by established local technological capacity in machine manufacture. Certainly, it is a slower process than technology importation, but it is a more certain process of development.

4.6 Profits: The Price of Progress

Rural electrification is widely deemed to have exceptional social value and considerable environmental benefit. While these warrant considerable efforts to expand rural facilities, and may justify the external subsidies or internal cross-subsidies needed to accommodate the special economic problems of such investments, they are not of themselves sufficient to motivate rural energy entrepreneurs. Rural energy entrepreneurs are seeking commercially viable investments. If, as we have accepted, the market is to play a major role in rural energy delivery it must also be accepted that the essential motivation of the

market is commercial profit. Successful rural energy planning must accommodate and consolidate many interests. The energy entrepreneurs must accept that social goals help create their markets, and that environmental goals can compel the use of less economically viable technologies. Correspondingly, and no less importantly, those with social and environmental responsibilities must accept that the power of the market comes with a price - and the price is profits for the entrepreneurs and economic viability for the utilities. Compromises, even sacrifices, may be necessary to find a balanced formula for rural electrification.

An early area of compromise and sacrifice is certain to be in determining target localities for village electrification. Having determined the direction and nature of support needed the question immediately arises: which villages have priority? Peri-urban bedroom communities?; rural market centres?; sites well suited for the available technology?; disadvantaged communities? The debate will be endless, and never satisfactorily resolved. The danger is that the energy entrepreneurs will be marginalized during the debate. If so, and if the compromise choice offers neither engineering possibility nor profit potential, they will simply exercise their option not to participate. The plan will have precluded the potential to bring to bear the power of the market, and at best settled for growth in lieu of development.

While the social development potential of rural electrification is accepted as given the economic development potential is less well understood. This is particularly important for both private energy entrepreneurs seeking profits and planners seeking economic development. Rural electrification does not appear to create economic activity: 'The experience of micro-hydro tends to lend support to the conclusion that "rather than rural electrification programmes causing increased wealth, economic dynamism, improved literacy, and other aspects of development, it may be that it is precisely in areas with such characteristics (already) that programmes are likely to succeed".'

The cumulative evidence suggests two lessons: (1) rural electrification localities must be selected based on a minimum availability of commercial consumers; and (2) rural electrification can complement and transform rural economic activity but probably cannot initiate it.

This implies that the eve customers, those consuming an output volume and load factor sufficient to justify the investment, are likely to be productive sector clients paying commercial rates. While debate is most certainly not closed there is ample evidence to suggest that rural electrification should not be targeted below 'areas of low income and productivity ... generally the larger villages ... with farms, irrigation, and agro-industries ... where there is generally a strong response from both households and businesses. Where electricity serves productive purposes, and where enough domestic consumers are in the "less poor" category, prices can be set to reflect costs ...'. Having said that, however, Turvey concludes by noting that 'with the exception of extremely poor areas ... consumer willingness to pay is an adequate monetary measure of economic benefits, and a good basis for pricing and investment decision'. It is logical to begin with the assumption that, in developing countries, villages with some productive activity will prove most viable. It is considered a rule-of-thumb for hydro-based schemes, with their relatively high capital investment and correspondingly high investment pay-back burden, to require a 'core' of commercial rate consumers. Ultimately, the decision to test these assumptions must be made by the rural energy entrepreneurs themselves; planners and practitioners both will learn from their experiences.



[Home](#) > [ar](#) [cn](#) [de](#) [en](#) [es](#) [fr](#) [id](#) [it](#) [ph](#) [po](#) [ru](#) [sw](#)



Village Electrification (SKAT, 1992, 128 p.)



Part 2: Generators

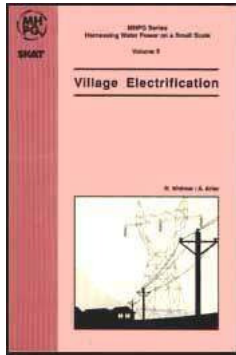

1. Synchronous generator
2. IMAG, using induction motors as asynchronous generators

Village Electrification (SKAT, 1992, 128 p.)

Part 2: Generators

1. Synchronous generator

The generation of electrical power is mostly done by a synchronous generator. This machine is robust, simple to control and almost maintenance free in a brushless (rotating rectifier) version. It generates electrical power with a frequency proportional to the speed of the rotor, so the electrical frequency and mechanical speed are synchronous, which explains the machine's name.

1.1 Working principles

The machine generates electrical power in the stator coils by a rotating magnetical field which is generally produced by a DC magnet. The DC power for this magnet can be supplied externally, but it is convenient to integrate a small generator, the exciter, on the same shaft within the same housing. In any case to feed this magnet, the DC current has

to be supplied to the rotor. A simple way is through two slip-rings, but this involves wear and regular maintenance. A more sophisticated, but maintenance free solution is to integrate a small AC generator (exciter) on the rotor, rectify the current and supply it to the rotor coil, all on the same shaft, avoiding any slipping contacts (therefore rotating rectifier). The excitation current for the exciter is provided by a DC current to the exciter stator which is generated by the output power of the main generator.

This method allows to design a clever system, integrating even a simple but efficient voltage control. Since the voltage of the main generator drops with an increasing load, its excitation has to be increased to compensate. This requires more current from the exciter, which is achieved by increasing its excitation. So the DC supply for the exciter stator can be used to control the main generator's voltage. Such a control is done electronically by an automatic voltage regulator (AVR). A certain output voltage is preset and the control adjusts the excitation to keep the output voltage under all loads close to the preset value. Today's brushless, synchronous generators include an AVR.

The machine is able to self-start by its residual magnetism: as soon as the machine rotates, a small output voltage is generated starting to feed a small current through the AVR to the exciter, which in turn increases the output voltage. This control loop develops the nominal output voltage within a few machine sums. It is possible that the residual magnetism was lost. In this case it has to be rebuilt. The same method as for asynchronous machines can be used and is described in the next chapter.

The frequency, however, has to be regulated, as an increased load will decrease the rotor speed. Such a speed control could be most simply done by hand or automatically by an automatic governor.

At least two important design/selection considerations for generators related to the control of MHP sets shall be pointed out here:

- the generator must be equipped with special bindings able to withstand the runaway speed of the turbine (in case of crossflow-turbines approx. 1.8 times the rated speed).
- if possible use standard generators. BYS Nepal for instance uses wherever possible 4-pole, brushless-type generators, equipped with an electronic automatic voltage regulator (AVR). These provide fairly constant voltage over a wide speed range which is important for manual or simple governor-based flow controls. Moreover they require virtually no maintenance.

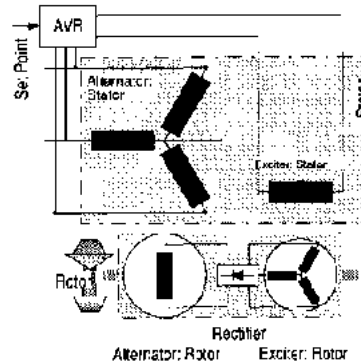

Fig 1 Principle diagram of a synchronous generator.

2. IMAG, using induction motors as asynchronous generators

As described in the previous chapter, the conventional generator for MHP (or PHP) is the synchronous generator. Specially for isolated grids it is often thought to be the simplest and adequate solution. There are, however, some situations where an asynchronous generator offers the same or even better possibilities, despite its well known disadvantages described below. Two such cases are:

- **the system is (even if not immediately, but in some near future) to be connected to a larger grid (e.g. regional, national supply...)**
- **investment capital is scarce and the planned system must be simple.**

This chapter shall introduce the reader to the basics of asynchronous generation and help to make decisions.

2.1 The Asynchronous Generator: an Induction Machine

The induction machine is very simple in construction, but tricky to understand and control. To get a feeling for this machine a short comparison with its competitor, the synchronous generator is given here.

advantages:

- **easily available in all power categories.**
- **cheap (compared with a synchronous generator at the same power rating). simple and robust construction.**
- **does not need DC excitation. does not need synchronization when paralleled to a grid. needs little maintenance (no slipping electrical contacts).**
- **self-protecting. In case of a short circuit or overload, it de-excites automatically and remains de-excited.**
- **simple operation. wide spread. Almost every electro workshop can handle it.**

disadvantages:

- **needs external magnetization energy -> additional equipment is needed for isolated operation.**
- **less efficient, especially below nominal power.**
- **less rotating mass -> less inertia, riskier to over speed.**
- **power characteristics are highly sensitive on the load -> complicated electronic control is needed in case the load is not constant.**
- **loss of residual magnetism in a short circuit or overload -> loss of self-start capacity.**

Talking about an asynchronous generator in this chapter, we will actually always refer to an asynchronous motor (same as induction motor) run as a asynchronous generator (IMAG = Induction Motor used as Asynchronous Generator). Almost any induction motor can be used as a generator, as seen by studying its symmetric torque/slip diagram. Note: the slip is the difference of the electrical frequency and the mechanical frequency (speed) normed with (divided by) the electrical frequency.

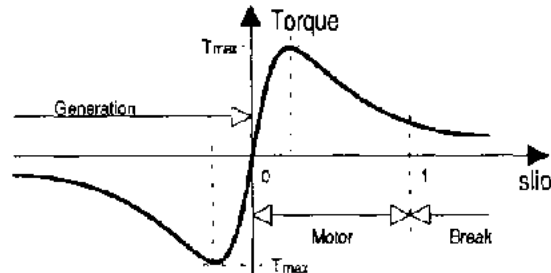

Fig 2 Torque slip (speed) diagram of an asynchronous machine.

slip < 0 over-synchronous speed -> rotor is forced to turn faster than the magnetic field,

mechanical power is transformed into electrical power. GENERATOR range. slip = 0 synchronous speed -> rotor is running idle, no power transfer, no torque.

0 < slip < 1 under-synchronous speed -> rotor is driven by the faster rotating magnetic field, electrical power is transformed into mechanical power. MOTOR range.

slip = 1 standstill -> rotor is blocked, no power transfer.

slip > 1 reverse speed -> rotor is forced to turn against the magnetic field. BREAK range.

The slip is a relative value and characteristic for asynchronous machines. The generated power (mechanical or electrical) depends on the difference between the electrical frequency (rotation of the internal magnetic field) and the mechanical frequency (rotation of the rotor). Hence the electro mechanical coupling of such a machine resembles a mechanical clutch, where the torque is transmitted over to slipping surfaces. A difference is that an asynchronous machine does not couple without slip. The power transfer is zero if both the electrical and mechanical frequency are equal (at $s = 0$ or synchronous speed). The clutch on the other hand couples best at synchronous speed! This behavior makes the asynchronous machine difficult to imagine.

To work as a generator the following main conditions must be fulfilled:

- the prime mover (turbine, motor ...) must speed up higher than the synchronous speed in order to produce slip and torque.

- the IMAG is not able to produce the energy for magnetizing its coils. It must be supplied the required reactive power from an external source (like a grid or a capacitor bank).

The torque/slip relation shows a pronounced maximum torque. As a motor this means loading the machine with a torque higher than this maximum will stop it; as a generator this means the break down of the power generation.

2.2 Working Principles

Induction machines are often called 'rotating transformers'. The shorted (secondary) winding on the rotor, the 'squirrel cache', is excited by the (primary) stator winding, which in turn is excited by the rotor. That is a transformer and in fact, with a blocked rotor, the asynchronous machine is a normal transformer with a shorted secondary winding.

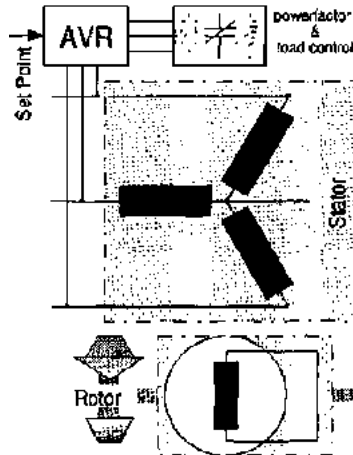

Fig 3 Principle diagram of a asynchronous generator.

We see (Fig 3) that the trick to use the shorted rotor 'coil' to produce the excitation current results in an amazingly simple construction (compare with Fig 1). Besides the stator and the rotor coil nothing else is needed. The rotor coil degenerates to some aluminum or copper bars embedded in the rotor iron, shorted at the ends with Cu or Al rings (therefore squirrel cache). This simplicity of construction is unique but also disables

a direct influence on the generated voltage (via excitation current) and moreover there is no simple relation between speed and frequency.

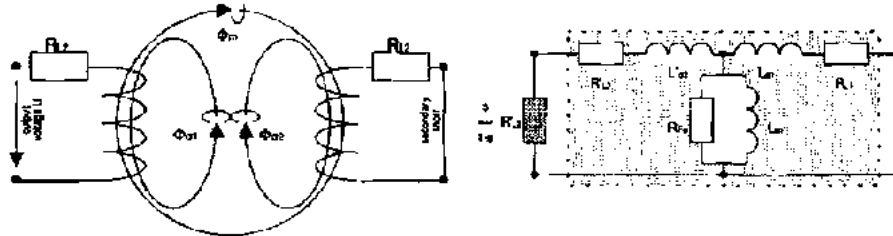

Fig 4 A simplified physical representation of a transformer. is the magnetic flux separated in a coupling component (index m) and two stray components (index a). This flux is modelled in a lumped circuit as inductance. Resistive losses are indicated as resistors (index L for coils, index Fe for iron)

To describe the behavior of the IMAG a simple electrical circuit is used. The machine is modelled by a transformer T-circuit (because it resembles a T see Fig 4), including coil losses (R_L) and stray losses (L) as well as iron losses (R_{Fe}) and the machine's inductance (L_m)

Working as a motor, the mechanical load is indicated as a resistor R which is a function of the slip s . Working as a generator s and hence R becomes negative, which means it becomes a power source (a negative resistor produces power = generator).

But a real, negative load cannot produce reactive power, therefore in generating mode the IMAG needs an external source for reactive power.

In case of a parallel operation to a larger grid, the reactive power can be drawn from it and there is no need for additional care (besides normal power factor correction). For an

isolated operation, however, we need to look at the machine a bit closer:

In the part 'power factor correction' we see that the reactive power of an inductance can be supplied (compensated) with a corresponding capacitor C. For a complete compensation, we would need an exact value of C in order to have identical U/I lines (both are straight lines) in the current/voltage diagram (see part 'power factor correction' Fig 6). Fortunately, in

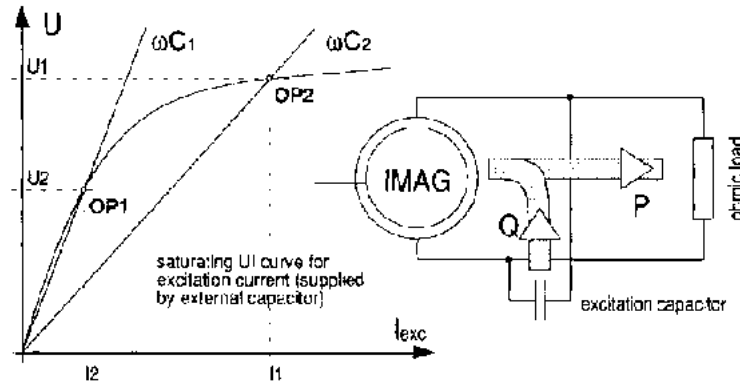

Fig 5 UI curve for the saturating excitation current and U_1 lines for two different capacitors at constant frequency. The resulting two stable operating points (OPT and OP2) are reached at very different output voltages U_1 and U_2 . The circuit besides shows the pow of power. The required magnetization power (reactive Q) is supplied by the excitation capacitor.

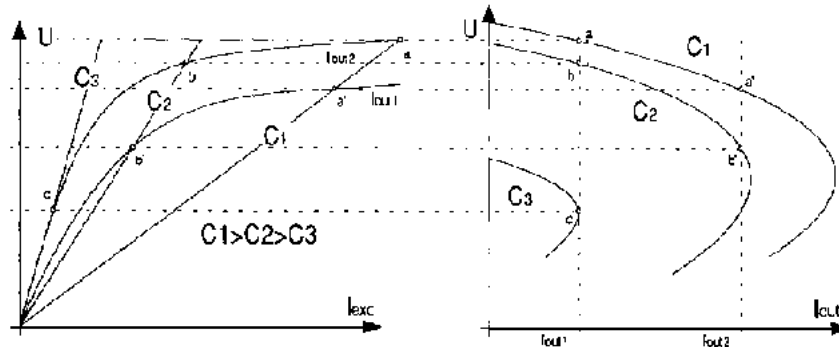

Fig 6 Relations of UI curves for varying excitation currents at constant $I_{0,}$ and the corresponding UI curves for the output currents at constant C . For a constant capacitor value the voltage varies with the output current along the C -lines (a-a', b-b'). the point c indicates that for C_3 the maximum output current is reached. All curves at constant frequency.

induction machines the reactive power need depends on the load and hence on the excitation current. This is due to the magnetic saturation effect of the iron. If we draw both the UI line of the excitation (bent line) and a capacitor (stright line), we see that a stable operation point, namely the point where the two lines cross, is possible (see Fig 5).

Unfortunately, as soon as a (variable) load is added and an additional current flows, two things happen: the generator voltage drops (see Fig 6).

- the frequency drops too (as it is proportional to the difference of rotor speed and slip, and the slip increases with the load (increased torque). Is the reactive power supplied by a fixed capacitance, the output voltage U varies widely with the output current I and there is a maximum current I_{max} . Each chosen C will produce another curve, with a higher I for

greater C.

Under load the IMAG changes voltage and frequency and shuts off at a certain current I_{max} (= a certain load). For almost all situations a control of U and I is needed. Only where the load is not varying (e.g. a single, permanent load...) or the generator is parallel to a large, rigid grid, we will not need any.

2.3 Voltage & Frequency Control for IMAGs

A control would measure at least the following values: voltage, current, phase, frequency and speed to determine the values for C, speed, dump load... to prevent the voltage U and the frequency f from exceeding nominal values (see Fig 7).

We actually need two controls: one for the frequency and one for the voltage, but both are interlinked which needs some care. Changing for instance the speed to adjust the frequency will also change the output voltage and vice versa. To avoid instabilities the control system has to be designed carefully. Here we will only mention some strategies to control the output voltage.

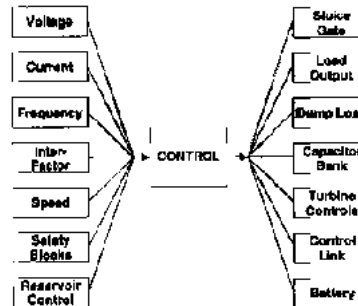

Fig 7 Control scheme for an IMAG in a MHP.

The following table (see Table 2) shall indicate some of the possibilities for a voltage control, which are described in some details afterwards. This will deepen the understanding of an IMAG and might allow to select a adequate control system:

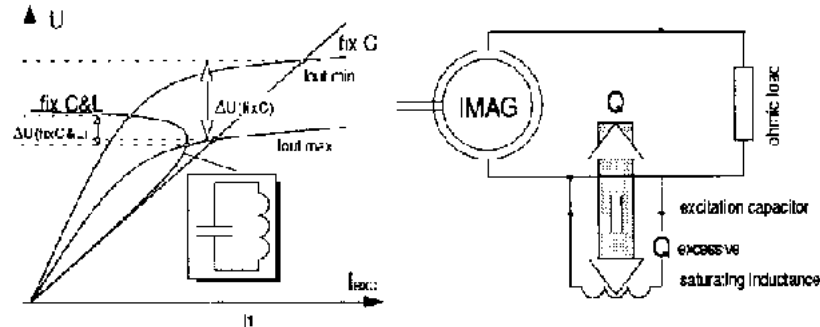

Fig 8 Reduce the output voltage swing by adding a saturating inductance.

Table I Possibilities to control the output voltage for a supply system with IMAG. The sequence corresponds to the paragraphs below.

a) Passive regulation with saturating inductance

The inconvenience with a constant capacitor is its excess reactive current at no load, when it is correctly dimensioned for nominal load. This excessive current overexcites the generator and results in high overvoltages.

By adding an inductance, which saturates at the nominal output voltage, some of the excess reactive current will be absorbed and the voltage stabilized. The capacitor has to be increased to compensate the decreased excitation current at the rated output. Besides the costly coil and moderate efficiency, this compensation ('control') is very simple not needing any further active control elements.

b) Voltage control by regulating solely the speed Ω_r

	adjust	fix	variable	remarks
a)		$I, C, L(l)$	Ω_r	no R
b)	Ω_r	C	r	no L, R
c)	C ω	r	Ω_r	no L, R
d)	C ω	I, L	Ω_r	no R
e)	R_{dump}	I, C, Ω_r		no L
f)	C, R_{dump}	r		

Table

Is the frequency of interest (for instance in DC applications like battery loader, lighting with bulbs...), the voltage can be adjusted by solely changing the rotor speed. The capacity is prefixed for no load.

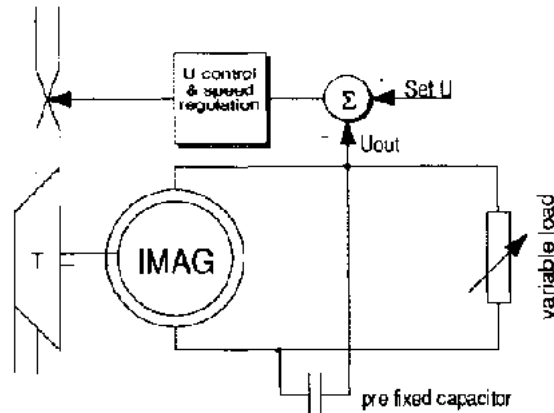

Fig 9 Controlling solely the voltage by regulating the speed. The frequency doesn't matter.

The control senses the voltage error ΔU and corrects the speed. In a simple setup this can be done by hand.

c) Voltage control by regulating C

In most cases we need also a good enough frequency stability (for instance $50\text{Hz} \pm 1\%$). Besides the rotor speed we need to control another parameter, conveniently the exciting current by varying C. If we tolerate voltage 'jumps', the control may be discrete, this means C could be switched to lower and higher values at certain currents (see Table 2), ensuring that the voltage remains within a defined range.

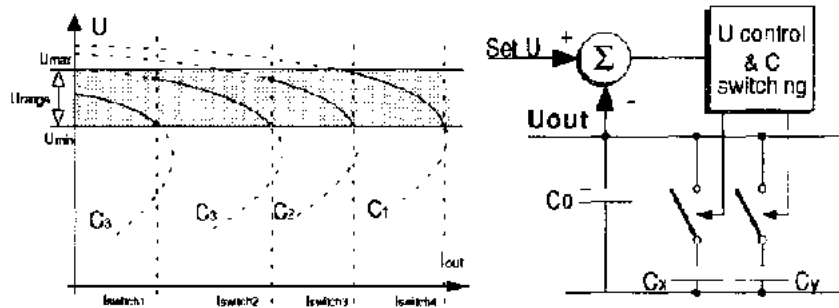

Fig 10 Switching between four combinations of excitation capacitor values to reduce the voltage swing.

The values for C are selected to keep U-range in acceptable limits.

A possibility to switch between four different C's is shown in Fig 10.

C_0 , C_x and C_y have to be determined experimentally. The switching to new C's will change the frequency and so the rotor speed has to be readjusted (which changes the voltage again, which is adjusted by a change of C, which changes again the frequency, which...

see the risk for instability?).

This system is relatively simple, even though using some control electronics. Such kinds of controls are widely used in voltage stabilizers ('fridge guards'...) and readily available.

d) Reducing the voltage 'jumps' in c) by combining a) and c)

We have seen in a) that the voltage variation for different loads can be reduced with a saturated inductance. Combining this solution with e) results in a smoother voltage regulation (see Fig 11).

e) Voltage and frequency control by load regulation

If the primary energy is abundant, the system could always be run at nominal power, avoiding any adjustment of C or Ω (similar to b). If the load varies, we could add dump loads to make up for the difference.

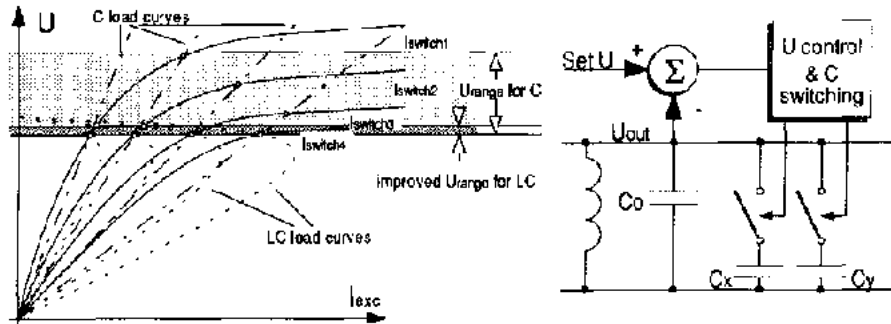

Fig 11 Reducing voltage variation by combining switchable C's with a saturating inductance.

yx	C	I_{out}
00	$C_4 = C_0$	$I_{switch1}$
01	$C_3 = C_0 + C_x$	$I_{switch2}$
10	$C_2 = C_0 + C_y$	$I_{switch3}$
11	$C_1 = C_0 + C_x + C_y$	$I_{switch4}$

Table 2 Capacitor bank switching: status of switches and the corresponding total values for C.

The control triggers at the prefixed output currents I_{switch} . Two switches x and y ; position 0 = off 1 = on.

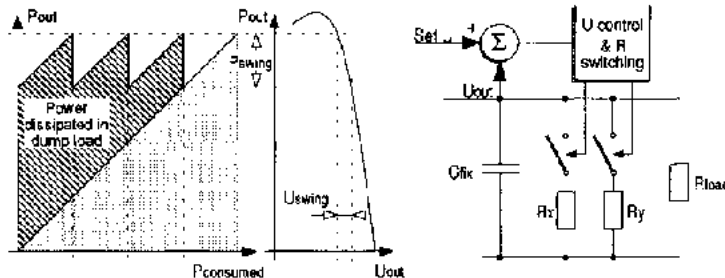

Fig 12 Stabilizing the voltage and frequency by keeping the load constant. By adding dump loads the power output swing is reduced. The number of resistors determines the swing amplitude.

Table 3 Dump load switching: status of switches and the corresponding total values for R.

Yx	R
00	R_0
01	$R_0 \setminus R_v$

10 $R_0 \setminus R_y$ 11 $R_0 \setminus R_x \setminus R_y$

Two switches x and y; position 0 = Off 1 = on;

yx	P	C
00	$\frac{1}{4}P_{max}$	C_0
01	$\frac{1}{2}P_{max}$	$C_0 + C_x$
10	$\frac{3}{4}P_{max}$	$C_0 + C_y$
11	P_{max}	$C_0 + C_x + C_y$

Table 4 Jet switching: status of switches and the corresponding input power and total values for C.

The control system is very much the same as in c) except we switch resistors instead of capacitors.

This dump resistors can of course be for any kind of non-time critical use (for instance heat or freeze water in a storage tank, storage cooker...) provided the average dump power is sufficient for this purpose.

This control system is cheap and convenient in most cases. It eliminates the need for a speed control system. The dump loads can also be connected anywhere on the grid, they don't add reactive power to the distribution lines.

f) Voltage and frequency control by load and input power regulation

If prime energy is scarce, the control system e) is not feasible. In some situations, however, it is easily possible to regulate the input power discretely. Suppose we use a pelton turbine with four jets. We could vary the power by simply switching the jets on or off in the range from $1/4P_{max}$ to P_{max} (see Fig 12). Each of this input power level is

chosen to produce a certain amount of electrical power. Each will need its particular, prefixed C, which could be switched together with the valves in the same way as in c).

The varying power demand within one input power level could be compensated by switched load resistors as described in e).

We would use two nested control circuits: the first selects the number of jets (and the appropriate C), the second control (not displayed here) makes the fine adjustment by varying dump loads. A particular disadvantage of this solution is the poor efficiency of IMAGs at low power output.

2.4 Particulars & Operation of IMAG

IMAGs are competitive as long as generation does not exceed some 10-100kW and the control circuitry remains cheap, simple and reliable (or omittable). The machine itself is about 50% cheaper than synchronous generators in this power range.

IMAGs can be wired for single or three phase.

Starting after loss of remanence

It is possible to lose the permanent magnetic field (remanence of the iron), which disables the machine from self-starting. This happens for new machines or after overloading the running machine (break down of current). In this case it is sufficient to supply some excitation current by a battery to the connectors of the running generator. A short pulse is required. The quickly growing generator voltage will burn the battery if it remains connected!

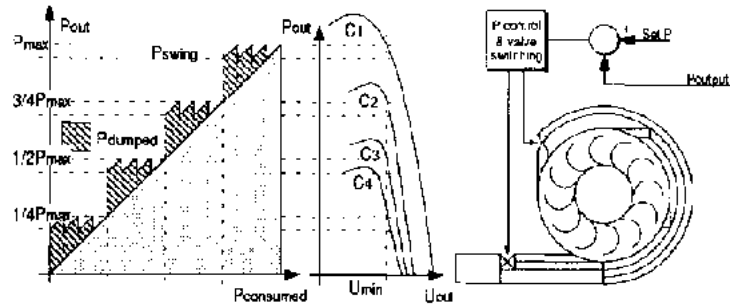

Fig 13 Reduce power loss by varying P_{mech} , and combine it with a load controller.

Less risky is the build up of a residual magnetic field in the machine by connecting a battery for a short moment to the machine at stand still. The DC current will produce a magnetic field, which will partly remain after switching the battery off.

IMAGs will not start under load!

Connecting an IMAG to a rigid grid is very simple and represents the most economic way of using it.

-neither voltage nor frequency control is necessary, both are maintained by the grid.

-no synchronization is needed. Speed up the generator to approximately synchronous speed, switch it to the grid, increase the speed to full power, that's all.

-no reactive power source is needed for the magnetization. the grid supplies it. To improve the power factor, however, a compensation capacitor should be connected (the same as for any other motor. Its value is optimized for the nominal conditions). Careful: the capacitor must not be connected before switching the generator to the grid. The

generator would excite end tee damaged,ifswitched on unsynchronized !



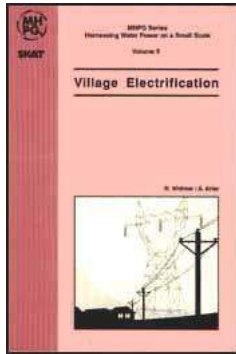

[Home](#) > [ar.cn.de.en.es.fr.id.it.ph.po.ru.sw](#)



Village Electrification (SKAT, 1992, 128 p.)

Part 3: Electrical control systems

 (introduction...)

-  1. Fundamental principles of electrical control systems
-  2. A concept for standardized electrical control systems
-  3. Specific problems with isolated, rural electrification schemes

Village Electrification (SKAT, 1992, 128 p.)

Part 3: Electrical control systems

This part is based on a manuscript prepared by S.L. Vaidya and B. Oettli. (S.L. Vaidya is the successor of B. Oettli as Head of Hydropower Department at BYS. Nepal)

This part concentrates on the design of the electrical control, protection & instrumentation systems for an isolated or small grid.

In addition, a few important facts concerning auxiliary equipment like cables and components for lightning protection will be briefly discussed.

Finally, with a special view to installation and operation of the equipment, a few crucial points like transportation of equipment, load management or capacitive load factors in cable networks will be highlighted.

The objective is to provide some specific tools in a narrow field which are practical and well proven and can be applied fairly straight forward.

1. Fundamental principles of electrical control systems

We need first to specify what the term control means in our context. For a small grid with a single generator and a simple power distribution, controlling mainly includes the stabilization of the line voltage and the frequency within certain given limits. This is normally done by measuring these values and then adjusting either the generating gear or the load.

Besides this the control must ensure the safety of people and equipment, shutting down the plant or set off an alarm if any danger occurs.

To control the electrical and mechanical system at least the control sub-systems shown in Table I are required.

Although references will be made at various points to the others, this section is basically dealing with the system control.

The electrical control system generally provides not only the 'control', but also 'protection' and 'instrumentation'. These three sub-systems have to provide a number of functions, the most important of which shall be outlined in the following paragraphs.

1.1 System Control

Electrical control signals enable and trigger essential electrical functions like voltage build-up, load control and management, normal and emergency deexcitation of the generator or shut down of the plant.

In basic electrical control systems like the designs shown in section 3) control is done manually through push buttons and switches. In schemes that are designed for a higher degree of automation, electronic, programmable logic controllers (PLCs) can provide fully automatic start-up and shutdown procedures.

1.2 Protection

While electricity is probably the most convenient form of energy presently available, its use involves certain risks. reduce danger to a minimum, national rules and international standards form a base for electrical safety. Protection systems have to be designed accordingly to fulfil the specified requirements which can basically be categorized into two groups: the protection of human beings (operators, consumers...), and the protection of property (generating equipment, appliances...).

1.2.1 Protection of Human Beings

Touching live parts is extremely dangerous and often even causes loss of life.

The effects of various intensities of earth fault currents through a human body are indicated in Table 2

control sub-system	governs the	controls the
speed control	turbine	turbine speed, frequency
voltage control	generator (or C see part: Generators)	line voltage
load control (see part: Generators)	dump load	voltage / frequency
system control	main switch, exciter	safety limits

Table 1 Control Sub-Systems

Earth Fault Current Range	Effect
Up to 10mA	- None
About 15mA - 30mA	- Can cause shock, suffocation, burns or cramps
Above 30mA	- Shock, suffocation, burns, can cause death
Above 500mA	- Can ignite a fire

Table 2 Damaging effects of electrical currents on human bodies

Protective measures are normally divided into three categories: basic, direct and indirect protection.

a) Basic Protection

Is ensured by the insulation of all life parts to prevent from a direct contact.

b) Direct Protection

Is ensured by simply placing electrical circuits and installations out of reach and by prevention of direct contact through enclosures, barriers or covers and housing. The degree of protection is best indicated with reference to the international IP classification. The IP-code consists of two figures: the first one indicates the degree of protection of persons from contact (or the penetration of solids), the second specifies protection

against penetration of water. Widely adopted IP classes are summarized in Table 3. In spite of providing basic protection, enclosures and barriers, accidents still may occur for instance in case of an insulation failure. In view of these cases direct protection can be enhanced by the use of residual current operated circuit breakers (RCCB) or earth leakage breakers/relays (ELB/R).

c) Indirect Protection

Is provided by a number of measures briefly mentioned hereunder. Earthing: electrical connection of all accessible, conducting parts like covers, frames or housings together and to earth (neutral potential see also chapter earthing). Also provide effective, automatic disconnection of the supply before a shock is likely to prove fatal. Use of Class 11 Equipment: appliances with double insulation, which have no exposed conductive parts. Electrical Separation: usually provided by isolating transformers with the secondary side floating (non-earthed). This is, however, limited to certain circuits and appliances only. The first method is mostly applied.

1.2.2 Protection of Property

This term generally covers the protection of generating equipment, including generator, electrical control system and power cables inside of the plant, the protection of transformers and the distribution system outside of the plant and the protection of consumer appliances.

Code BSS	Degree of Protection ... of Persons against Contact with Live Parts	1st Numeral ... of Equipment against Ingress of Solid Foreign Bodies and Dust	2nd Numeral ... of Equipment against Ingress of Liquid
IP 00	no protection	no protection	no protection
IP 20	protection against finger contact	protection against particles >12mm	no protection
IP 41	protection against tool contact etc.	protection against particles >1mm	drops of condensed water are not harmful'
IP 43	protection against tool contact etc.	protection against particles >1mm	neither rain nor sprayed water (30 - 90° from horizontal) is harmful.
IP 54	complete protection	no harmful deposits of dust in the interior	splashing water from any direction does no harm
IP 55	complete protection	no harmful deposits of dust in the interior	hosed water does no harm
IP 65	complete protection	complete dust protection	hosed water does no harm
IP 67	complete protection	complete dust protection	immersed in water does no harm

Table 3 Standards of Protection of el. Apparatus against Contact of Persons and Water

Most of these subjects are covered by standard text books or manufacturers' data sheets. Specific aspects to which some attention is paid here are: The dimensions of copper wires, the aerating factors for cables, the coordination of current breaking devices and conductors, the breaking capacities and time/ current characteristics of breaking devices and lightning protection.

a) Capacity and Derating Factors for Cables

The permissible current rating of any current carrying device (e.g. generator, cable...) is of course dependent on the actual layout (e.g. the effective cabling used. Table 4a shows correct cross sections for Copper wires) but also on ambient/atmospheric conditions.

section	diameter		max. current density			
			stationary		moving	
	wire	cable	A	A/mm ²	A	A/mm ²
mm ²	mm	mm				
0.75	0.98				5	5.00
1	1.13		6	6.00	10	10.00
1.5	1.38		10	6.67	15	10.00
2.5	1.78		15	6.00	20	8.00
4	2.28		20	5.00	30	7.50
6	2.76		25	4.17	40	6.67
10	3.57	4.01	40	4.00	60	5.00
16	4.51	5.08	60	3.75	80	5.00
25	5.64	6.35	80	3.20	100	4.00
35	6.68	7.51	100	2.96		
50	7.90	8.68	125	2.50		
70	9.44	10.62	150	2.14		
95	11.00	12.37	200	2.11		

Table 4a Copper wire diameters for different currents and installations.

While designing protection for an electrical system, the operating conditions need therefore to be taken into account. Of particular importance are aerating factors for power cables and generators.

Elevated temperatures considerably reduce the rated currents. Correction factors for different ambient temperatures are given in Table 4.

Bundled cables do not dissipate heat very well therefore, their rated current drops (or for a given current the cross-section must increase).

Ambient Temperature [°C]	Correction Factor
25	1.06
35	0.94
40	0.87
45	0.79
50	0.71
55	0.61
60	0.50
65	0.38

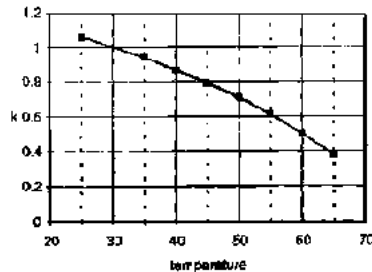

Table 4 Correction factors k for cable ratings at different ambient temperatures

Some correction factors for grouping single and multicore cables are shown in Table 5.

b) Coordination of Current Breaking Devices and Conductors

As a general rule, conductors in isolated or small grids should be designed for the maximum power that can be generated.

Still, overload conditions can be created for instance by load imbalance in a three phase system. Such overload or short-circuit currents must be interrupted before they cause temperature rises harmful to insulations, joints, terminations and surroundings of the

conductor. There must be proper coordination between the protective device and the rating of the conductor.

Notes: These factors are applicable to groups of cables all of the same size and equally loaded, including groups bunched in more than one plane. Where spacing between adjacent cables exceeds twice their overall diameter, no reduction factor needs to be applied Example: a group with 10 single core cables protected by a 60 A fuse. The minimum rating for each cable is $60 \text{ A} / 0.59 = 101.7 \text{ A}$.

Type of cable and installation condition	number of loaded cables											
	4	6	8	10	12	16	20	24	28	32	36	40
single core cables #												
factor per cable	0.80	0.69	0.62	0.59	0.55	0.51	0.48	0.47	0.41	0.39	0.36	0.35
multi core cables #	2	3	4	5	6	8	10	12	14	16	18	20
factor per cable	0.80	0.70	0.65	0.60	0.57	0.52	0.48	0.45	0.43	0.41	0.39	0.38

Table 5 Correction Factors for Groups of More than Three Single Core Cables or More than One Multicore Cable

As a rule of thumb the following coordination guidelines can be applied:

factor	Subject
1.00	designed full load current.
1.25	rated breaking current of any protective device.
1.50	(corrected) rating of current carrying conductor (see Table 4.8.5).

Table 6 Correction factor for rated currents

It is understood that such design practice might lead to slightly overdimensioned, but safe!, power cables. On the other hand, this practice takes into account tolerances of fuses and other breaking devices that do not necessarily operate at their rated value.

c) Breaking Capacity and Time/Current Characteristics of Current Breaking Devices

Special attention has to be paid to ensure that a protective device is in fact capable of breaking a short circuit current in due time. The designer therefore has to assure that the breaking capacity is higher than the possible maximum current, a value that should be ascertained by the generator manufacturer.

Effectiveness of short circuit protection can be checked by applying the adiabatic equation.

$$t = \frac{k^2 \cdot A^2}{I_2}$$

where t = duration of short circuit [s]

A = conductor cross section [mm²]

I = fault current [A]

k = factor for conductors & insulating material {13}

For	k
Copper conductor insulated with pvc	115
Copper conductors insulated with 60°C rubber, 85°C rubber	134
Copper conductors with 90°C thermosetting insulation	143
Copper conductors insulated with impregnated paper	108
Mineral-insulated cables with copper conductors	135
Minimum conductors insulated with pvc	76
Minimum conductors insulated with 60°C rubber, 85°C rubber	89
Minimum conductors 90°C thermosetting insulation	84
Minimum conductors insulated with impregnated paper	71
Mineral-insulated cables with aluminium conductors	87

Table 7 k values to be used in the adiabatic equation for short circuits up to 5 second duration (source: Kempe Engineer's Yearbook)

The calculated time t must be equal or greater than the time taken by the protective device to clear the fault. As a basis for such comparisons, exact time/current characteristics of fuses or breakers used are indispensable. As an example a characteristic curve for fuses is shown in Fig 1.

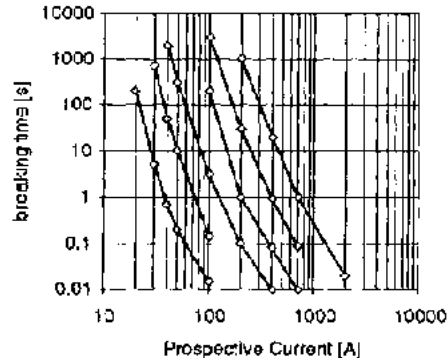

Fig 1 Time/current characteristic for fuses - a sample

d) Lightning Protection

In lightning-prone areas, persons and equipment need to be protected against atmospheric overvoltage. The basic measure for lightning protection is the use of lightning arrestors that divert the surge to the ground.

For high tension transmission systems, it is common practice to place a set of suitably sized surge arrestors at the outgoing lines of a power station and further sets every

kilometer of a transmission line. For small low tension systems, 500 V arrestors should be installed close to the equipment.

Adequate earthing must be provided for every arrestor (see part 'Earthing').

1.3 Instrumentation

The instruments incorporated in the control panel shall basically enable the operator to monitor simple electrical system parameters like voltage, currents, frequency and to record load and energy generation! supply-curves. Furthermore they should indicate abnormal conditions and facilitate operation (e.g. load prediction and management).

Instruments should be easily readable and ergonomically installed. They should be grouped logically to avoid confusion. Is an instrument part of the control (for instance speed), and any action has to be taken by the operator, she shouldn't have to move at all. All elements of a control system have to be within reach. The degree of instrumentation will mainly depend on the requirements of the owner and on the complexity of the scheme.

2. A concept for standardized electrical control systems

Electrical control systems for small hydro schemes have been standardized worldwide to a large extent. However, those standards are designed for plant capacities above 1 MW. For schemes with capacities below 100 kW these standards cannot be applied directly, but have to be simplified and optimized with respect to the specific technical and economical requirements.

Category	Type of Operation	Number of units	Type of governing
A	isolated mode	1	manual flow control
B	isolated mode	1	hydraulic governor
C	isolated mode	2 or more	hydraulic governors
	isolated mode and grid operation	1 or more	hydraulic governors

Table 8 Definition of categories of complexity for MHP schemes

Remarks: Instead of hydraulic governors electronic load controllers could be used without changing the complexity table.

The major reason BYS have not installed any load controllers to date is simply because all concerned schemes suffer from a lack of water - most plants have daily storage ponds - and minimization of discharge is therefore a must.

The common factor of the two sub-classes of category C is synchronisation (either of the two units or of one single unit to the grid). As there are only minor differences between these two cases they shall further on no longer be distinguished.

Even within the MHP range, the degree of control, protection and instrumentation can vary considerably. Determining factors for the degree of automation are:

- **type of operation (isolated mode or connection to a grid)**
- **number of units**
- **type of speed governing system (manual or automatic control)**
- **capacity of plant**
- **category of operator (state-owned or private) - main consumers (domestic or industrial load)**
- **particular wishes of owners**
- **cost of electrical components**

The optimal electrical system tends to provide high reliability, safety and user friendliness at competitive prices through equipment and design that is standardized and kept as simple and cheap as possible (but neither simpler nor cheaper than that!).

In connection with MHP schemes a concept that supports achieving these goals is based on the following elements:

- split of schemes into three categories of complexity**
- a standardized design for each of the three respective electrical systems**
- criteria for the selection of adequate components**

2.1 Categories of Complexity

As a basis for the determination of the appropriate electrical system, BYS have divided its hydro power projects within Nepal into three categories of complexity.

2.2 Standardized Designs

In accordance with the above defined categories of complexity, BYS has worked out three standardized electrical systems. These will be outlined based on the corresponding single line diagrams on the following pages. For symbols, abbreviations of components and a summary refer to Table 9 and 10.

Apart from the automatic speed and voltage control of the generating set, the electrical control functions for run-up, voltage build-up, load control etc. are of manual type (push buttons) for all categories.

Electrical control systems based on a programmable logic controller (PLC), providing fully automatic control would form another category, characterized by a much higher level of automation. These systems are of limited relevance in this context and shall not be

included here.

2.2.1 Standard Electrical Control System Category A

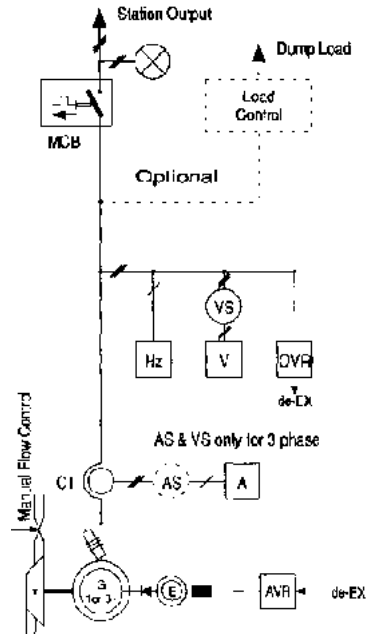

Fig 2 Single line diagram for the control circuit of category A. The load control is optional.

This system (see Fig 2) represents the basic level of automation and may well represent the absolute minimum requirements for an isolated electrification scheme. Besides a fuse/circuit breaker to limit the output current and an over voltage relay, which deexcites the generator to limit the line voltage, this system has to be manipulated completely manually

by an operator. Instrumentation is marginal, only three values are displayed: The (line) voltage, current and frequency. An hour meter is, however, highly recommended. The operation hours not only determine energy and power output but also the cycle of equipment servicing.

In case the load is simple e.g. does not vary, this might prove an adequate and very economic solution. In case of varying loads, which will be the case in even very simple distributions with several customers, the stability of this system will very soon reach its limits. It is not feasible either to keep a skilled operator all day long on the controls to regulate even moderate fluctuations. An automatic load controller can improve this situation (see part generators, IMAG).

As this system has no synchronisation gear, it cannot run parallel to a grid if a synchronous generator is used.

2.2.2 Standard Electrical Control System Category B

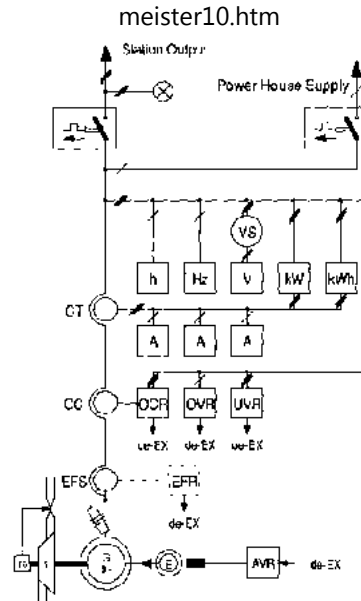

Fig 3 Single line diagram for the control circuit of category B. The earth fault relay is optional.

This category (see Fig 3) represents the majority of the realized rural electrification projects. Compared to category A it provides first of all an automatic speed regulation through a hydraulic governor. It is equipped with additional automatic safety controls like over current, under voltage and (optional) earth fault relay which all de-excite the generator.

Besides this all operations are manual and a skilled operator is needed.

This system is equipped with a substantially improved instrumentation: power, energy and

operation time are displayed. This allows a simple recording of production/consumption, which is the base for any efficient energy management (water management), consumption prediction and tariff structures.

Still no synchronisation gear is added limiting this system's use to isolated operation.

G	=	Generator
T	=	Turbine
TG	=	Turbine Governor
E	=	Excitor
AVR	=	Automatic Voltage Regulator
MSFU	=	Main Switch Fuse Unit
FSU	=	Fuse Switch Unit
MCCB	=	Moulded Case Circuit Breaker
MCB	=	Miniature Circuit Breaker
ABC	=	Air Break Contactor
OVR	=	OverVoltage Relay
UVR	=	UnderVoltage Relay
OCR	=	OverCurrent Relay
OFR	=	OverFrequency Relay
RPR	=	Reverse Power Relay
EFR	=	Earth Fault Relay
EFS	=	Earth Fault Sensor
kWh	=	Kilowatt hour Meter
KW	=	Kilowatt Meter
Hz	=	Frequency Meter
Hz/Hz	=	Double Frequency Meter
PF	=	Power Factor Meter
h	=	hour meter (time totalizer)
V	=	Volt Meter
V/V	=	Double Volt Meter
VS	=	Volt Selector
A	=	Amp Meter
AS	=	Amp Selector
CT	=	Current Transformer (also CS, CC)
S	=	Automatic Synchronizer
Syn	=	Synchroscope

Table 9 Abbreviation for the electrical symbols in the circuit diagrams (Fig 2, 3 & 4)

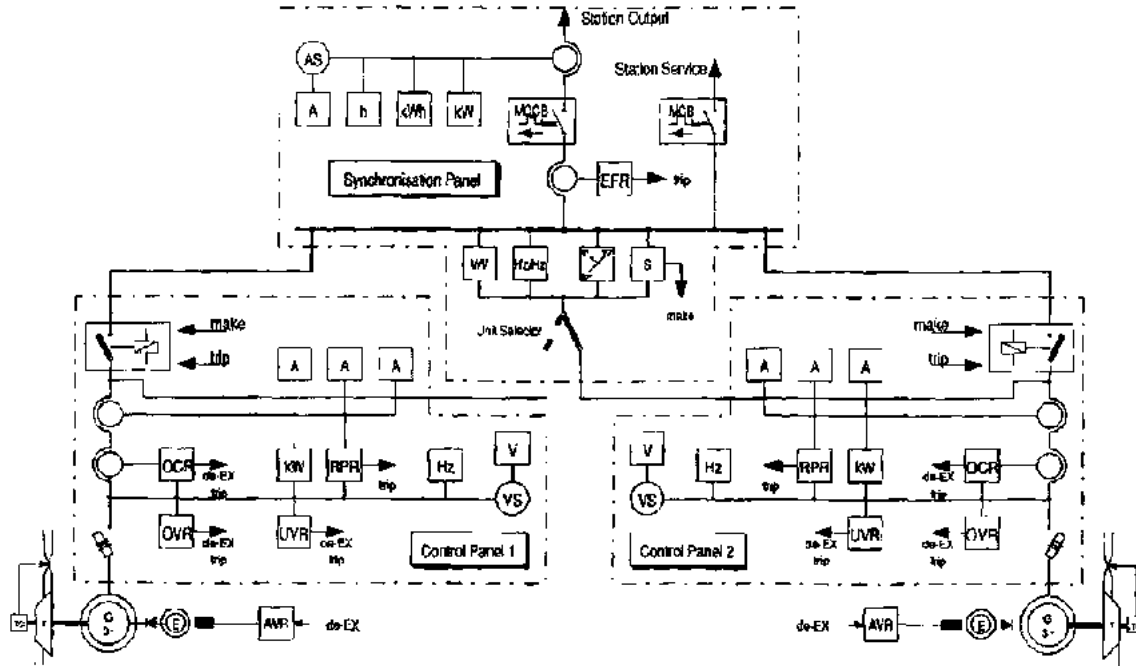

Fig 4 single line diagram for the control circuit of category C. Control panel I and 2 are identical.

		A	B	C
SCHEME	rated output	< 25 KW	< 30 KW	< 100 KW
	running hours/day	18	18-24	24
	mode	isolated	isolated	grid
	# units	single	single	two
	station supply	locne	yes	yes

SYSTEM CONTROL	flaw	manually	hydraulic governor	hydraulic governor
	generator/exciter	AVR push buttons for run-up & emergency shutdown	same	same
	load	on/off	on/off	on/off
	generator breakers	none	none	yes controlled by synchronizing unit
PROTECTION	overvoltage (OV)	OV relay	OV relay	OV relays
	undervoltage (UV)	none	UV relay	UV relays
	overcurrent (OC)	circuit breaker or fuse, thermal overload relay	same as A add OC relay	same as B
	reverse power (RP)	none	none	RP relays preventing the two sets from motoring
	earth fault (EF)	none	optional	EF relays
INSTRUMENTATION	volt meter	yes selection switch	yes selection switch	yes selection switch
	ammeter	yes selection switch	yes	yes
	frequency meter	yes	yes	yes
	kW meter	none	yes	yes
	kWh meter	none	yes	yes
	time totalizer	none	yes	yes
	synchronization panel	none	none	yes synchroscope, dual V- & A-meter
PANEL CONSTRUCTION		compact design can be wall- or directly alternator- mounted	single housing, foot- mounted	type separate panels, foot- mounted
SPECIFIC REQUIREMENTS & BENEFITS		tolerates only moderate load changes	suitable for normally varying loads, increased safety, better support for operators than A	increased availability and easier maintenance (always 50% power from the other unit), better part load efficiency (switch off second unit)
OPTIONS		Time totalizer, electronic load controller for better regulation and/or to	earth fault relay (has often been requested by the customer), for run-off-the	load controller(s)

		reduce operating cost	diver activities: load control instead of hydraulic governor	
--	--	-----------------------	--	--

Table 10 Summary of the three categories AB&C

2.2.3 Standard Electrical Control System Category C

The design of this electrical system (see Fig 4) is fairly complete regarding protection and instrumentation. Still, it is a manual control system with a semiautomatic paralleling procedure, without any provision for fully automatic control through a PLC.

2.3 Components

2.3.1 Components for Standard Systems

Some more details on components that are either of importance for control or that have been neglected so far.

Breakers / Over Current Protection:

To switch off the generator and disconnect it from the grid, there are two suitable alternatives:

* **Moulded Case Circuit Breakers (MCCB)**. They are remote controllable (for category C systems).

Air Break (power) Contactor (ABC) in combination with thermal overload relays and HBC-fuses or with OCRs.

For very small, normally single phase systems (A), miniature circuit breakers (MCBs) will also serve for this purpose.

Control push buttons should be fitted to provide manual overriding signals for remote controlled breakers in category C systems.

Over-/ Undervoltage Protection:

Protective relays are normally available in different versions:

- * single-phase or three-phase**
- * under- and overvoltage separate or combined**

The best solution will mainly be determined by price and availability.

Instrumentation Transformers:

Ampmeters should never be used with the full load current flowing through. Instead use always current transformers (CT) and standard 5A ammeters. In rare cases (e.g. synchronisation equipment) PTs might be required.

Synchronizers:

Today's synchronizers are mostly fully automatic, switching the incoming breaker. Still, some simpler non-automatic versions are available which prevent only from manual closing of the breaker under invalid conditions. As operators of rural electrification schemes are mostly not very experienced, strict use

*** of automatic synchronizers is certainly the best solution. It could provide manual control for speed and voltage instead of the fully automatic adjustment through the synchronizers control signals. BYS has always followed this semi-automatic approach with its twin unit schemes.**

2.3.2 Additional Equipment

The standard designs are fairly basic and cost-effective solutions (at least categories A and B). Additional components that aim to improve safety and reliability can, however, be incorporated at extra cost. Also the option to operate the station at least part-time unattended is provided. Especially in state run rural electrification schemes, there is a clear tendency towards a higher level of automation.

Typical additional features are:

Speed Monitoring Systems: with at least two independent subsystems for emergency overspeed triggering (e.g. first stage: electro mechanical sensor with speed-indicator and over speed relay; second stage: mechanical overspeed-switch).

Pressure Monitoring Systems: normally simple pressure gauges for penstock/turbine inlet and governor pressure.

- Shutdown-Solenoids: for automatic /emergency shutdown of governor or inlet valve.**
- DC-Supply System: to provide an uninterruptible supply for the (DC) control system. It is based on lead acid or alkaline batteries.**
- Status & Fault-Indicator Panels: together with DC control systems.**

2.3.3 Sources of Origin

In most developing countries one will have to distinguish between two groups of components: components that are locally available and components that have to be imported.

Components that generally fall into the first group are: instruments, switches, push-

buttons, auxiliary relays, fuses, CTs, terminals, cables, glands...

Imported components are typically: protective relays, synchronisers, PLCs...

There are some components, which can fall in one group or the other group (medium-technology): MCCBs, ABCs... It is advisable, however, to avoid experiments with locally produced protective relays.

2.4 Summary and Recommendations

A set of standardized electrical control systems has been described above. In practice, however, it might not always be easy to relate a given project clearly to one of the categories specified and to choose the respective standard system, mainly for three reasons: * the classification does take into account neither the type/skill of consumer nor operator. * individual requirements/ requests of the customers might force a redesign to a non-standard system. components might not be available at all or only at prohibitive costs.

To provide assistance for cases where either none of the proposed standardised designs seems to fit properly or simply to visualize the design and selection process, a list of design/ selection criteria shall be given hereunder.

3. Specific problems with isolated, rural electrification schemes

The foregoing chapters have all focused on the initial design of the electrical control system for a small hydro scheme.

This chapter aims to summarize a few other important aspects that are related rather to installation and operation of a plant. Experience has shown that, if these points are not taken into account during design or the operator is not prepared for when taking up

regular operation, serious problems might arise. Most of them are very particular to isolated, rural electrification schemes and are, therefore, seldom tackled in standard textbooks.

Criteria	Subject	Recommendations
1	General / Cost	The electrical system should be as simple and cost effective as possible, but neither more simple nor cheaper than that!
2	Operation procedures	Should be easily understandable by the operators, not only by the designer!
3	Operating conditions	Have to be carefully studied in order to select the adequate equipment. Of particular importance are: <ul style="list-style-type: none"> * ambient temperature, altitude, humidity (impact on generator, cabling, housings) * type of load: lighting only, heating, motors... (impact on governing, control, protection...)
4	Protection	To provide safety for human beings, animals, equipment and plant is the most crucial aspect while designing electrical control systems. First priority must, therefore, be given to select adequate protective devices.
5	Control / Emergency-Shutdown	At least one manually operable (emergency) shutdown device should be incorporated in the system. This can be a mechanical device (pencillock or turbine-valve) or an electrical system (generator de-excitation, shutdown solenoid for governor or inlet valve) or both. With increased levels of protection such a device should be automatically triggered
5	Instrumentation	Should enable the operator not only to monitor electrical parameters (like V, A, Hz) but also to observe abnormalities and to support load management / forecast (kW, kWh meter) and periodical maintenance (time total zero). All instruments and control elements are placed logically and ergonomically to avoid 'human mistakes'.

Table 11 Design Criteria and Recommendations

3.1 Transportation of the Equipment to the Site

Since many rural electrification schemes are located in very remote areas and have no access by motorable roads, transportation of the equipment may pose a major problem. The two alternatives are their transportation by helicopter or porting by man or animals.

Air lifts for small hydro equipment are only considered if no other option seems to be feasible, as the high cost can hardly be afforded.

In Nepal, the well adopted weight rate for a porter is 40 kg, however, there are specialised "heavy duty" porters carrying up to 100 kg. If the path allows it, a group of porters, equipped with bamboo-sticks or the like, might even be able to carry loads up to 400 kg.

Whenever equipment has to be ported to the site, this has to be kept in mind during the design of the whole system. Mechanical components (in particular to the turbine) are normally designed in a way that they can easily be taken apart for transportation.

For generators and control panels, however, this might pose some problems. Generators, for instance, have either to be carried by a group of men or the rotor has to be dismantled. The latter procedure requires qualified, experienced people to disassemble the generator, supervise porting and reassemble the rotor at site. Furthermore, the risk of damaging the generator windings during transportation has to be considered.

The electrical control system for a category C scheme is designed to be splitted into 3 panels (twin units with 2 generators and 1 synchronizing panel).

Typical weights for these components are given in Table 12.

	Power Output	Weight of	
		Generator	Control Panel
A	25 kW	290 - 260 kg	40 - 70 kg
B	40 kW	340 - 380 kg	60 - 90 kg
C	2 x 50 kW	2x 360 - 420 kg	3x 80 - 100 kg

Table 12 Typical weights of generator and control panel for the categories A, B and C.

For smaller sets (about 5 kW output power), generators and control panels can be carried by a single porter.

3.2 Load Management

This general term covers three subjects that are all bound to the load of a plant and often pose problems: - (low) load factors

- (part time) overload - phase imbalance

As the following paragraphs will show, almost every rural electrification scheme has to fight with at least one or all of these constraints. Both design and operation have to be optimizing procedures in order to maximize the use of electricity, but not to exceed the limits.

3.2.1 Improving Load Factors

With regard to the revenue of a scheme, operation at a high load factor is of highest importance. At low load factors the consumers will not be able to afford the electrical energy and consequently operation of the plant will fully depend on subsidies.

If electricity is predominantly used for domestic lighting in the morning and evening hours only, low load factors are inevitable. As an example, the initial load factors of average state-run micro hydro schemes in Nepal are in the range of 10% to 25% only. With the

resulting revenue, none of these plants can cover more than 50% of the regular operation and maintenance cost.

Improvement by additional use of electrical energy can mainly be achieved in the area of: cooking: change from cooking on open fire to electric stoves (or even better: heat storage cookers) cooling: power for commercially used electrical refrigerators, cottage industry, operation of flower-mills sawmills, etc., either newly set-up or having been driven by diesel engines before.

Even though this might not be the job of the designer of the electrical control system, every assistance should be provided to enable the operating agency to promote non-lighting appliances. Especially in small scale industries the consumption might quickly be relatively large in regard to the plant's output. For critical equipment like large electrical motors, the potential user as well as the operator might be in need of support. Such may vary from design, selection and supply of star-delta-starters to modifications of the speed governing system of the scheme.

3.2.2 Handling of Overload

Despite of very poor load factors, the (peak) load demand is most often heavily underestimated. The pace of load development is difficult to predict, but in practice frequently leads to an uncomfortable situation: during peak demand hours, a generating set is getting overloaded within a few weeks from starting regular operation of the plant.

Once the total consumer load is higher than the generating capacity, load scheduling is required.

Keeping in view the load factor the plant should thereby always be as close to its maximum capacity as possible.

With manually governed plants, manually operated cut-off or change-over switches will serve to do this job. Much easier and more elegant is the use of modern electronic load controllers for this purpose. Advanced models on today's market incorporate load management features that cut off non-essential loads, but maintain the supply of power to priority loads in case of system overload.

3.2.3 Coping with Phase Imbalance

Before the problem of peak time overload arises, most rural electrification schemes have to face difficulties due to imbalanced load in three phase systems. With the steady increase of the consumers demand, one of the phases might soon be overloaded. Phase loads must roughly be equalized then. Depending on the system and the characteristics of the load demand, one of the following measures has to be taken: rewiring and reconnection of consumers

- load switching by hand.**
- load balancing as a feature of modern load controllers**

3.3 Capacitive Power Factors

This phenomena is bound to transmission and distribution systems based on multicore cables. Such cables are capacitive and the longer they are the higher becomes the capacitive load to the generator (see part 'power factor correction'). If no inductive loads like motors are connected, the system is consequently operating at a capacitive power factor with the ultimate effect on increased generator currents and possible instabilities.

Since generators are normally designed to operate at inductive power factors from 1.0 to 0.8, it is advisable to consult the manufacturer if capacitive load conditions can be foreseen.

3.4 Line Distortions

The use of thyristor based load controllers produces non-sinusoidal voltage and current waveforms. If these effects are not cured (with proper filters for instance) they will distort the whole electrical system, impairing all installations from the generator to consumers appliances. In the worst case, this effect might damage sensitive, electronic appliances. It influences rating and disturbs the voltage regulation of the generator.

If in doubt, both the generator and the appliance manufacturer should be consulted.



[Home](#) > [ar](#) [cn](#) [de](#) [en](#) [es](#) [fr](#) [id](#) [it](#) [ph](#) [po](#) [ru](#) [sw](#)

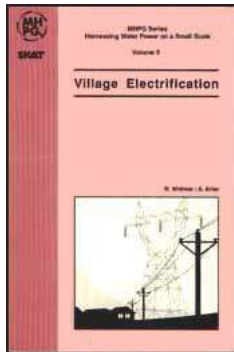

Village Electrification (SKAT, 1992, 128 p.)

Part 4: Power factor correction

 (*introduction...*)

 1. Phasor diagram

 2. The power factor in isolated grids

 2. Power factor in isolated grids

 3. Power factor correction

 4. Measurement of the pf

 5. Calculation examples for the compensation capacitance

 6. Summary, rules, recommendations:

Village Electrification (SKAT, 1992, 128 p.)

Part 4: Power factor correction

To understand the power factor and its importance, we need an understanding of the energy transmission in electrical systems. Analogue to mechanical systems, electrical energy can be dissipated by 'friction' (like a break) or, if we use AC, periodically stored and released (like a pendulum). Electrical energy is therefore 'moving' in three ways: unidirectionally, oscillating or in a combination of both. This depends solely on the impedances, the kind of loads in the system. Is there only active load (real impedance e.g. resistors like bulbs, heaters...), energy flows unidirectionally. Is there only reactive load (imaginary impedance like coils, condensators...), energy purely oscillates on the line. Under mixed conditions (complex impedances) the unidirectional and oscillating energy flows will superimpose.

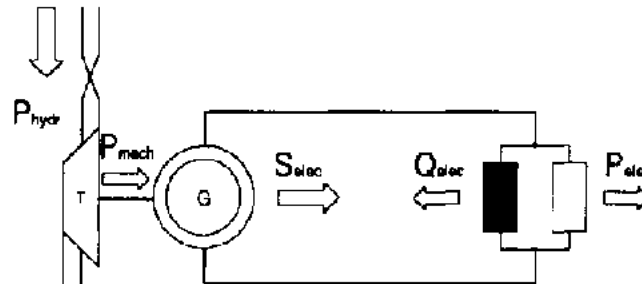

Fig 1 Power flow in the setup: (MHP) turbine generator - inductive/ resistive load.

The hydraulic power is transformed in mechanical power by the turbine, then to electrical power by the generator. The load partly dissipates, partly reflects this power. The generator apparently produces the power S_{elec} , but only the real component P_{elec} is supplied by the turbine and consumed by the load. The rest, Q_{elec} , is oscillating on the line.

What does this mean in terms of currents and voltages? In the unidirectional flow, the current and the voltage are exactly in phase, in oscillating flow the current and voltage are exactly a quarter of a period out of phase, either the current is leading or the voltage is leading (for a 50 Hz signal this is a time lead (or lag) of 5 ms). Leading or lagging depends on the type of the impedance: is it inductive (coils etc.), the current will lag, is it capacitive the current will lead the voltage.

In mixed flow, the phase is somewhere between zero and a quarter a period. Commonly, the 'out of phase' of current and voltage is used as a measure for the 'quality' of the load and is closely related to the power factor.

1. Phasor diagram

A simple way to display this behaviour is the phasor diagram. We draw (see Fig 24) two orthogonal axes. The horizontal is the real axis and the scale for real values (or active components like resistors). The vertical axis is the scale for imaginary values (or purely reactive components like inductances). A phasor is a vector ('arrow') drawn in this plain representing a quantity like an electrical current, voltage or power. The length (in units of the scale) indicates the strength, the direction (in degrees clockwise from the real axis) indicates the phase of this quantity.

The voltage U for instance in Fig 2 is drawn with no phase angle (e.g. in direction of the positive real axis to the right). This is an arbitrary selection. The current I_{active} in a resistor R due to U 's voltage is in phase with the voltage, so it points in the same direction as U . The current I_{reactive} in the inductance L (coil) lags the voltage by 90° , so it points vertically down. It is purely reactive as it is parallel to the imaginary axis. And now the clue of the phasor diagram: the total current I_{apparent} is the vector sum of the two current vectors. A vector sum is drawn (or calculated) by adding at each end of a vector the beginning of the next. The vector drawn between the beginning of the first and the end

of the last is the vector sum. In case of only two vectors which are perpendicular the resulting figure is a rectangular triangle, for which the calculations are very simple (Pythagoras). This case applies to all parallel circuits (R//L, R//C and R//L//C)

2. The power factor in isolated grids

2.1. Single Phase with a Single Load

The impedance shall be mixed inductive parallel to resistive (L//R). The voltage is U for both. The total current, I_{apparent} , is the vector sum of I_{activ} and I_{reactive} (90° lagging).

Or {1}

which says the current triangle is rectangular. The phase between I_{apparent} and the voltage U is

$$\cos \varphi = \frac{I_{\text{reactive}}}{I_{\text{apparent}}}$$

$$\text{OR } \sin \varphi = \frac{I_{\text{reactive}}}{I_{\text{apparent}}}$$

[2]

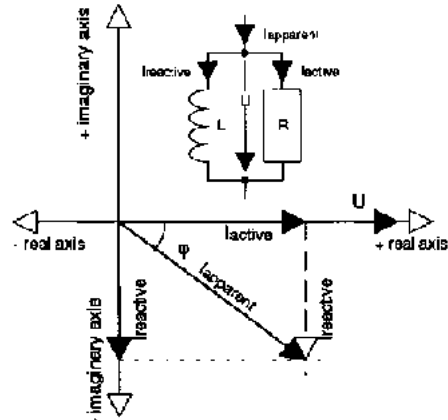

Fig 2 Phasor diagram for currents and voltage in a parallel circuit (inductance II resistor).

Multiplying each of this currents by the voltage U, we get the similar vector triangle (scaled with U) for the three powers. If not mentioned differently I means from now on I_{apparent}

Power supplied by the generator:

$$\mathbf{S = U \cdot I ; Apparent Power [kVA] \{3a\}}$$

Power which is consumed:

$$P = U \cdot I \cos \varphi = S \cdot \cos \varphi ; \text{Active Power [kW]} \{3b\}$$

Power which oscillates:

$$Q = U \cdot I \sin \varphi = S \cdot \sin \varphi ; \text{Reactive Power [kVAr]} \{3c\}$$

The power factor pf is defined as

$$\cos \varphi \quad P/S = P/(U \cdot I) \{4\}$$

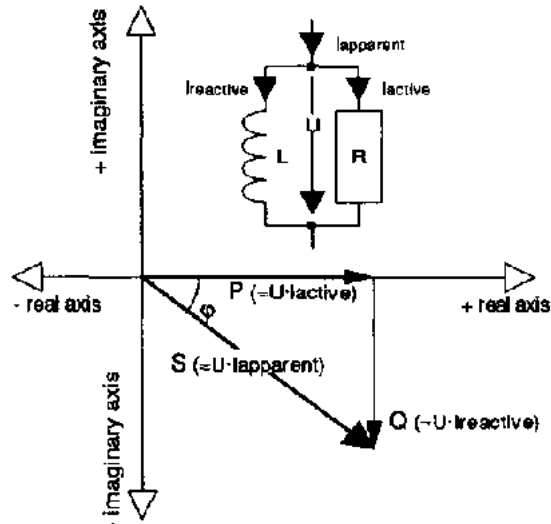

Fig 3 Phasor diagram for the electrical power in a parallel circuit (inductance II resistor).

The phase angle φ is the same as for the currents (formula 4), so in a setup as described, it could also be derived by the currents. Sometimes the formulas in Table I are useful.

		P	Q	φ	pf
S=	P	-	$\sqrt{P^2 - Q^2}$	$\frac{P}{S \cos \varphi}$	$\frac{P}{P_f}$
	Q	-	-	$\frac{Q}{S \sin \varphi}$	$\frac{Q}{\sqrt{1 - pf^2}}$
P=	S	-	$\sqrt{S^2 - Q^2}$	$S \cdot \cos \varphi$	$S \cdot pf$
	Q	-	-	$Q \cdot \cot \varphi$	$Q \cdot \frac{pf}{\sqrt{1 - pf^2}}$
Q=	S	$\sqrt{S^2 - P^2}$	-	$S \cdot \sin \varphi$	$S \sqrt{1 - pf^2}$
	P	-	-	$P \cdot \tan \varphi$	$P \sqrt{\frac{1}{pf^2} - 1}$
$\varphi=$	S	$\arccos\left(\frac{P}{S}\right)$	$\arcsin\left(\frac{Q}{S}\right)$	-	-
	P	-	$\arctan\left(\frac{Q}{P}\right)$	-	-
pf=	S	$\frac{P}{S}$	$\sqrt{1 - \left(\frac{Q}{S}\right)^2}$	-	-
	P	-	$\frac{1}{\sqrt{\left(\frac{Q}{P}\right)^2 - 1}}$	-	-

Table 1 A compilation of important conversion formulas.

Each formula is expressing the unknown (first column) as a function of two variables (first row & second column).

In a purely reactive load, there is no energy absorbed in the time average, hence no power consumed. Energy-meters (kWh meters) do not count reactive energy and so reactive power is not sold. But still there is an apparent current flowing, although partly oscillating (reactive energy), which produces losses on the transmission lines. To run a distribution system efficiently means minimizing these blind currents (reactive currents) by minimizing the phase angle j . Ideally j would become zero and the power factor one.

$\cos j = \text{pf} = 1$ and $\sin j = 0$ for $j = 0$ {5a}

In this case the apparent power equals the active power and the reactive power becomes zero

$S = P$ and $Q = 0$ {5b}

2. Power factor in isolated grids

2.2. Single Phase with Several Different and Parallel Loads

$$S^2 = \left(\sum_i P_i \right)^2 + \left(\sum_i Q_i \right)^2$$

$$\cos \varphi = \frac{\left(\sum_i P_i \right)^2}{\left(\sum_i P_i \right)^2 + \left(\sum_i Q_i \right)^2} \quad (6)$$

In the case of several parallel loads, the powers are summed differently. The following formula is read like: " ...the square of the total S is the square of the sum of all P and the square of the sum of all Q..." It is important not to mix up the sequence of squaring and summation!

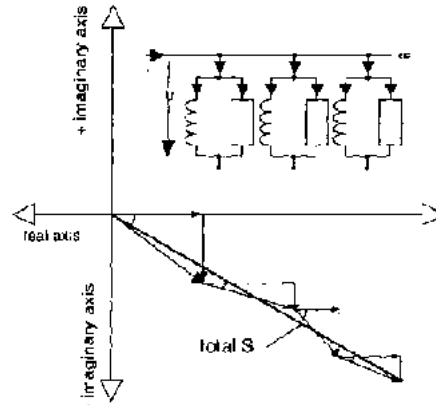

Fig 4 Phasor diagram to determine S in a parallel circuit of several inductances and resistors.

2.3. Three Phase with a Single, Balanced Load

In this special but frequent case, the calculation is the same as for the single phase, single load except a scaling up by the factor square root three, if U is the phase voltage U_{ph} and I is one (of three equal) phase current I_{ph} and S , P and Q are the total powers of the three phases.

$$S = \sqrt{3} \cdot I_{ph} \cdot U_{ph}$$

$$\text{from } 3 \cdot I_{ph} \cdot \frac{U_{ph}}{\sqrt{3}} \text{ or } 3 \cdot U_{ph} \cdot \frac{I_{ph}}{\sqrt{3}}$$

$$P = S \cdot \cos \varphi = \sqrt{3} \cdot I_{ph} \cdot U_{ph} \cdot \cos \varphi \quad \{5\}$$

$$Q = S \cdot \sin \varphi = \sqrt{3} \cdot I_{ph} \cdot U_{ph} \cdot \sin \varphi$$

FIGURE

The consumer is not directly concerned with the power factor as he does neither pay the reactive power nor get anything done by it. His power factor, however, is part of the overall system and contributes to an efficient (or poor) performance.

In most countries a control of the consumer's pf exists (or is on the way), in order to guarantee a satisfying system's performance. Normally, a minimum value for the pf is set (a value of $\cos \varphi = 0.8$ for example) and any consumer having a pf below this value is punished by a higher tariff or by paying a fine. He may be rewarded with lower tariffs or discounts if he reaches power factors close to one.

What was discussed before, leads to the following three conclusions for isolated grids:

1 Simple generators like asynchronous generators are unable to deliver reactive power Q without special measures. Their generation characteristics are also sensitive to varying pf = > keep pf = 1 and constant.

2 To minimize the costs for installations and losses, the grid should carry the minimum current which primarily means no reactive current. = >keep pf = 1 and compensate close to the inductivities.

3 Is the mechanical power of the prime mover the limiting factor (water flow, head...),

this power should be transformed in pure active power P by the generator. -> keep $\text{pf} = 1$

3. Power factor correction

We have seen that in real grids a degrading pf is unavoidable as soon as inductive loads are connected. Inductive loads are any kind of appliances using magnetic fields such as electric motors, generators, transformers, chokes etc. This leads to higher currents in the grid than necessary. For a given apparent power and voltage, the current varies with the pf as shown in Fig 5.

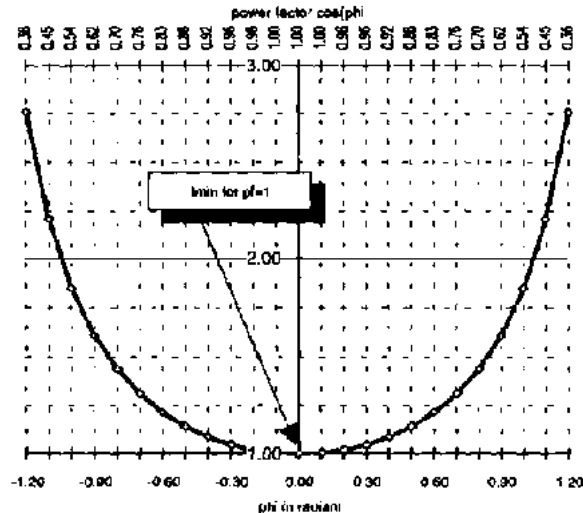

Fig 5 Ratio apparent to active current as a function of the power factor.

It is at a minimum (equal to I_{\min} if the reactive power Q disappears for a pf of one and

risers quickly as the pf diverts from one.

To compensate the power factor, it is easiest to add a device having the same but negative reactive current, parallel to the inductive load. So the two reactive currents will cancel each others. Such an element is the capacitor as we have already seen.

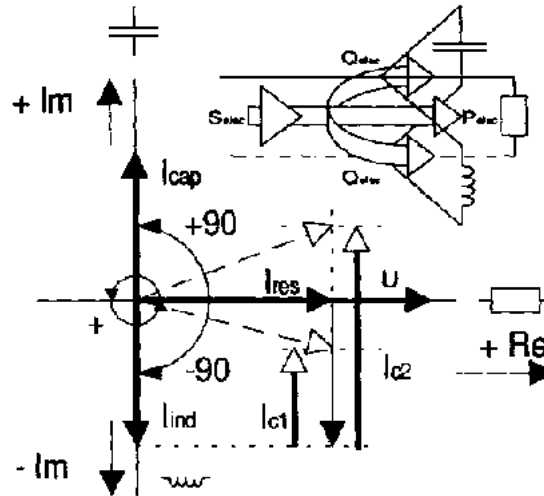

Fig 6 Compensating an inductive with a capacitive current.

Fig 6 displays the compensation of a reactive load /L) with a capacitor. The inductive current I_{ind} has to be compensated with the capacitive current I_{cap} . If I_{cap} is too small (I_{c1}), we still find an under compensated load (inductive type). If I_{cap} is too high (I_{c2}), we find an overcompensated load (capacitive type). To choose the correct capacitor we can use the following calculations (f is the line frequency):

$$I_L = U / (2 \cdot \text{pf} \cdot L) \text{ and } I_C = U \cdot 2 \cdot \text{pf} \cdot C \quad \{8a\}$$

for full compensation these two values must be equal:

$$I_L = I_C = > 1 / ((2 \cdot \text{pf} \cdot L)^2 \cdot L) \quad \{8b\}$$

It is convenient to use the value 'CRP = Capacitance per Reactive Power:

$$CRP = C / Q = 1 / (2 \cdot \text{pf} \cdot U^2) \quad (9)$$

For a given line voltage U and frequency f, CRP is constant and the compensation capacitor can simply be calculated as:

$$C = CRP \cdot Q \quad \{10\}$$

line	CRP [$\mu\text{F}/\text{kVAr}$]		
	1 Φ	3 Φ (per phase)	
		star	delta
110V/60Hz	220	-	-
220V/50Hz	66	-	-
190V/60Hz	73	73	24
380V/50Hz	22	22	7.5

Table 2 Capacitance per Reactive Power [$\mu\text{F}/\text{kVAr}$] for some important line voltages and frequencies.

$$\begin{aligned}
 C &= CRP \cdot (Q_{full} - Q_{part}) \\
 &= CRP \cdot (tg\phi_1 - tg\phi_2) \cdot P \\
 \text{or } C &= CRP \cdot \left[\sqrt{\frac{1}{pf_1^2} - 1} - \sqrt{\frac{1}{pf_2^2} - 1} \right] \cdot P \quad \{11\}
 \end{aligned}$$

Often, however, a full compensation is not wished and the load is kept slightly inductive (say pf = 0.9). In this case not the full reactive power has to be compensated (-> pf1), but the one reduced by the less stringent power factor (Pf2).

Tube lights use a built-in choke to ignite the tube and as an AC current limiter. The choke is a coil and responsible for the very low power factor (below 0.5) of this illumination. A single tube-light is often compensated by a series capacitance (see Fig 71 to avoid interference with centralized multiservice systems (line carriers). In small grids, however, tubelights can be compensated by a parallel capacitance. Several tube lights controlled by a single switch are centrally compensated with a single capacitance (see Fig 7).

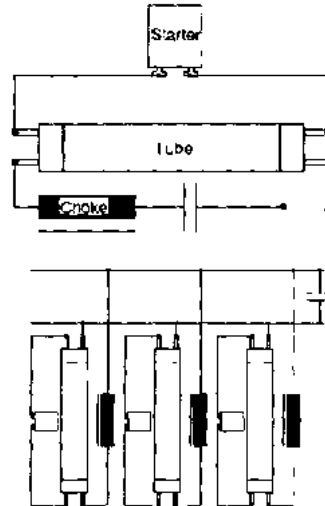

Fig 7 pf compensation of tubelights.

There are of course situations where the load is capacitive, for instance long cables tend to have rather high capacities. In this case, the load is compensated exactly in the same way just with inductivities (coils). We could of course let capacitive loads compensate inductive loads by a clever grouping strategy of the consumers, avoiding expensive pf compensation gear.

Fig 8 displays a geometrical interpretation of a pf correction. It shows that with the same installed power S I active power can be gained (P gain) by improving only the pf.

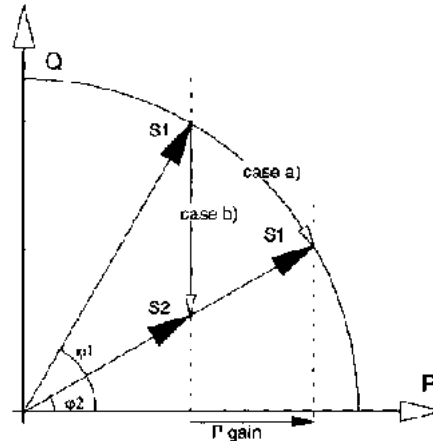
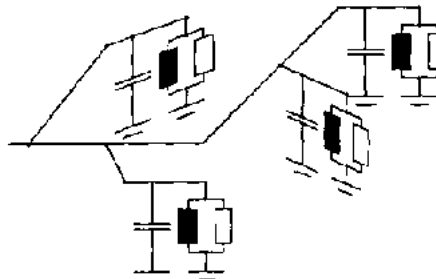

Fig 8 A geometrical interpretation of the influence of a power factor reduction (j_1 , to j_2) on the power (P, Q & S) in a load. a) S constant: 'move on the circle'->in creases P, decreases Q b) P constant: 'move straight down' >decreases S and Q

3.1. Individual Correction



FIGURE

The easiest way to ensure a good pf is to compensate each disturbance where it occurs e. g. to correct every inductivity on the spot, for instance by connecting the correct compensation capacitor to the same power switch, socket etc. Unfortunately this system depends fully on the awareness of the consumer or a tight control by the producer. It might also be costly and not compensating accurately enough. advantage: cheap (consumer pays), simple, minimum currents on the entire grid. disadvantage: producer has no immediate influence to improve pf. Additional pf correction might be necessary.

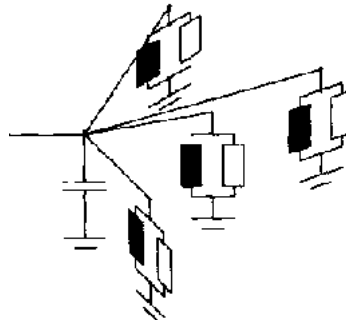
3.2. Sector Compensation**FIGURE**

Large grids are subdivided in sectors and each sector could be compensated at its feeder (for instance after the transformer). A sector might be an entire village or an industry. Certainly the pf of the sector will vary considerably with time. It is therefore necessary to connect a variable pf correction capacitor. This is usually a complete system which senses the phase and connects or disconnects capacitors from the supply. Such 'automatic power

factor correction' (APFC) systems are rather complicated and expensive. Sometimes a single capacitor, which is exchanged from time to time to adjust the pf, is sufficient. In this case the pf fluctuation should be small over short intervals. advantage: using APFC allows almost perfect, adjustable compensation of sectors. disadvantage: excess reactive currents in the sector, expensive with APFC; without adjustment procedure is difficult.

3.3. Global Compensation

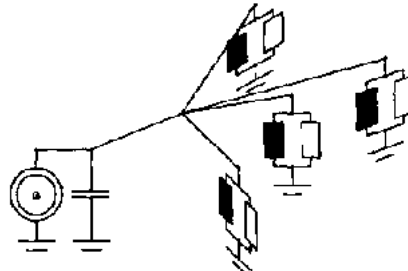

Figure

If the grid is small, it could be regarded as one single sector and compensated by a APFC system sited in the power house.

A capacitive load control as needed in an asynchronous generator might be combined with an APFC and reduce costs.

advantage: complete, immediate control at the generator, full compensation of the generator.

disadvantage: excess reactive currents on the entire grid.

A sophisticated, large scale system will combine all three strategies. For a small grid,

however, the first might be the most efficient for limited financial resources. pf compensation is never static and will change with time. A gradual investment in this issue is possible.

4. Measurement of the pf

The pf is easily measured by an instrument called "cos ϕ meter". But it can be determined by some simple measurements and calculations with a normal Volt, Amp and kWh meter:

The kWh meter is used to determine the active power P. On its name plate it is indicated how many revolutions correspond to a kWh (some constant k); hence counting the number of revolutions in a certain time, for instance rpm, reveals P.

$$p = (60 \cdot \text{rpm}) / k$$

example: rpm = 1, k = 2

$$P = 2 = 30 \text{ kW} \{12\}$$

With the amp meter and the volt meter the apparent current and the voltage are measured. The apparent power S is then:

$$S = U \cdot I$$

$$\text{and pf} = P/S = P/U \cdot I \{13\}$$

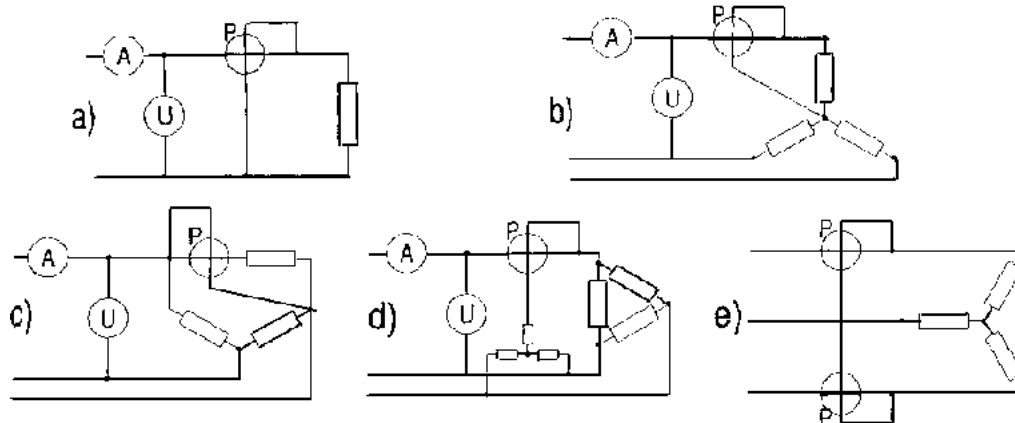

Fig 9 Measuring the power factor. a) single phase circuit b) circuit to measure a 'star' load c) circuit to measure a 'delta' load d) external star point circuit to measure a 'delta' load e) Aron circuit, which uses only two power meters to measure the total P in an unbalanced three phase system.

To measure a three phase load, this method is only applicable if the load is balanced. For a star connection the line-voltage and current and P are measured as shown in Fig 91;). Then using

$$S = \sqrt{3} U I$$

we find

$$\text{pf} = \cos \phi = \frac{P}{S} = \frac{P}{\sqrt{3} U I}$$

In a delta connection circuit c) would be used. Often the kWh meter cannot be inserted as

shown. In this case an external star point can be built (circuit d).

Is the load asymmetric, each phase has to be measured separately. There is the so called Aron circuit which allows to measure the total power with only two kW meters (circuit e). In a small grid, knowing all pf of the installed appliances, the total pf can be calculated instead of measuring (see example 3).

5. Calculation examples for the compensation capacitance

Example 1: Single Phase

This example will first supply us with all the necessary formulas (collected from above) for the subsequent examples and does not use any numerical values.

i) Compare two loads, one purely reactive, the other partly inductive, if the active power P and the line voltage U are the same.

ii) Let us consider a single phase motor at a rated voltage U with a power factor pf . Without compensation the current I and the active power P are measured. What is the apparent power S , the power factor pf and the reactive power Q ? What value must a capacitor have for full compensation and for a compensation up to a given pf_{min} ?

$$S = U \cdot I \quad \text{and} \quad pf = \cos \varphi = \frac{P}{U \cdot I}$$

$$\text{i) for } pf = 1 \rightarrow P = S \text{ and } Q = 0 \text{ and } I = \frac{P}{U}$$

$$\text{for } pf < 1 \rightarrow S = \frac{P}{pf}; \quad Q = \sqrt{S^2 - P^2} \text{ and } I = \frac{S}{U}$$

$$\text{ii) } C = CRP \cdot Q \quad \text{values for CRP in Table 2}$$

$$C = CRP \cdot \left[\sqrt{\frac{1}{pf_{min}^2} - 1} - \sqrt{\frac{1}{pf^2} - 1} \right] \cdot P$$

FIGURE

And now we do some calculations with these formulas

1a) A consumer needs 11 kW active power from a 220 V single phase supply:

i) if he doesn't use reactive power (only resistive load)

- the power factor pf is:

pf = $\cos \varphi = 1$ as $j = 0$ for $Q = 0$ the apparent current I: $I = P/U$ as $S = P = 11\text{kW}/220\text{V} = 50\text{A}$

- the apparent power S: $S = P = 11 \text{ kVA}$ the reactive power Q: $Q = 0 \text{ kVAr}$

ii) but if he uses reactive power and the power factor is only $\text{pf} = \cos \varphi = 0.5$, then we obtain the following:

- pf is: $\text{pf} = \cos \varphi = 0.5$

- I is: $I = \frac{P}{U \cdot \cos \varphi} = 100\text{A}$

- S is: $S = \frac{P}{\cos \varphi} = 22\text{kVA}$

- Q is: $Q = \sqrt{S^2 - P^2} = 19\text{kVAr}$

FIGURE

We see that for the same active power we now use twice as much current in ii), which means we would have to double the capacity of all electrical installations.

lb) A single phase motor shows on the nameplate: P: 2.2 kW; U: 220 V; cos j : 0.65; f: 50 Hz

$$C = CRP \cdot \left[\sqrt{\frac{1}{pf_1^2} - 1} - \sqrt{\frac{1}{pf_2^2} - 1} \right] \cdot P$$

$$C = 66 \cdot \left[\sqrt{\frac{1}{0.65^2} - 1} - \sqrt{\frac{1}{0.9^2} - 1} \right] \cdot 2.2 = 99 \mu\text{F}$$

The pf is to be corrected to the minimum allowed value cos j = 0.9 by adding adequate capacitors.

compensation	cosφ	P (kW)	Q (kVar)	S (kVA)	I (A)
no	0.65	2.2	2.57	3.38	15.38
yes	0.9	2.2	1.08	2.41	11.11

Table 3 Comparison of compensation in example lb

Example 2: Three Phase

Again at the beginning a list of the needed formulas. Suppose a balanced three phase supply and a balanced load is given.

$$S = \sqrt{3} \cdot I_{ph} \cdot U_{ph}, \quad P = S \cdot \cos \varphi \text{ and } Q = S \cdot \sin \varphi$$

$$\text{and } I = \frac{P}{\sqrt{3} \cdot pf \cdot U}$$

What is the difference to the single phase case?

Besides the square root three factor in the relations power to voltage and current nothing changes!

i) A three phase motor shows on the nameplate: P: 10 kW; U: 220/380 V; pf = 0.75; f: 50

Hz

$$C = CRP \cdot \left[\sqrt{\frac{1}{pf_1^2} - 1} - \sqrt{\frac{1}{pf_2^2} - 1} \right] \cdot P$$

$$C = 7.5 \cdot \left[\sqrt{\frac{1}{0.75^2} - 1} - \sqrt{\frac{1}{0.9^2} - 1} \right] \cdot 10 = 30 \mu F$$

The current is reduced from

$$I_1 = \frac{P}{\sqrt{3} \cdot pf \cdot U} = \frac{10'000 \text{ W}}{\sqrt{3} \cdot 0.75 \cdot 380 \text{ V}} = 20.25 \text{ A}$$

$$I_2 = \frac{10'000 \text{ W}}{\sqrt{3} \cdot 0.9 \cdot 380 \text{ V}} = 16.88 \text{ A}$$

and S and Q

$$S = \frac{P}{pf} \text{ and } Q = P \cdot \sqrt{\frac{1}{pf^2} - 1}$$

are reduced from 13.3 to 11.1 kVA and 8.8 to 4.8 kVAr respectively.

The power factor is to be improved from pf = 0.75 to pf = 0.9. Choose the correct capacitor for a delta connection

Table 4 Comparison of compensation in example 2

compensated	cos j	P [kW]	Q [kVAr]	S [kVA]	I [A]
no	0.75	10	8.8	13.3	20.25
yes	0.9	10	4.8	11.1	16.88

Sometimes compensation is also formulated as follows: 40% of the above motor's active power P has to be compensated (it is assumed that the motor's Q is more than 40% of P). The reactive power compensated by the capacitors is:

40% of 10 kW = 4 kVAr if the capacitors are delta connected, their capacity per phase is:

$$C = 4 \text{ kVAr} \cdot 7.5 \text{ mF/kVAr} = 88 \text{ mF}$$

Example 3: A Small Grid

Suppose we have to determine the compensation $\cos j$ for the small grid described in Table 5. It is a single phase, 240/480V system (see chapter SWER) with $S = 60 \text{ kVA}$ installed power. The big loads use the 480V line to reduce the currents and simplify the compensation.

No	consumer	No	description	rating		power uncompensated		compensation			
				(V)	(kW)	p.f.	P (kW)	Q (kVAr)	S (kVA)	Qc (kVAr)	@C (uF)
		1	heat & light	240	0.90	1.00	0.80		0.80		
25 houses			subtotal			1.00	20.00		20.00		
		1	heat & light	240	2.00	1.00	2.00		2.00		
		1	motor	480	5.00	0.65	5.00	5.85	7.69	4.59	63.45
		2	motors	480	3.00	0.65	6.00	7.01	9.23	5.51	38.07
1 mill			subtotal			0.71	13.00	12.86	16.29		
		25	tubelights	240	0.34	0.45	1.00	1.98	2.22	1.73	3.83
		2	motors	240	2.00	0.65	4.00	4.68	6.15	3.67	101.52
		1	motor	480	5.00	0.65	5.00	5.95	7.69	4.59	63.45
		1	welding	480	8.00	0.60	8.00	10.87	13.39	8.66	119.67
1 workshop			subtotal			0.61	18.00	23.17	29.34		
supply			total	480		0.82	51.00	36.03	62.45	23.25	321.24

Table 5 pf compensation for a small grid - an example.

Explanations: Each item shows its rated voltage and power, the total power for all connected items and the value for the compensation capacitor and the compensated reactive power Q_c to achieve an improved pf of 0.97. Under the subtotals the uncompensated powers P , Q and S for the respective heading are compiled and the resulting pf is shown. The generator voltage is assumed to be 480V so under 'supply

**total', the compensation capacitor is indicated for this voltage and a global compensation.
CRP(240V) = 55.26 1pF/kVAr, CRP(480V) = 13.82 [m/kVAr].**

A calculation shows that without a compensation the global pf is 0.82 and the load would exceed the installed capacity. The uncompensated total apparent power S is 62.5kVA (well above 60kVA). Although the pf is not too bad, a rigorous compensation can reduce S substantially. After correcting the pf to 0.97 (either by compensating each inductive load or globally at the generator) the apparent power has shrunk by 10 kVA to S = 52.5 kVA and is now well within the rated value. (Note: A pf of 0.97 might be rather high and normally not appreciated. In this case, however, the power gain justifies this compensation.)

Actually with this compensation we gain 9 kW of active power without adding any generation power! $P_1 = S \cdot pf_1 = 60 \text{ kVA} \cdot 0.97 = 58.2 \text{ kW}$ $P_2 = S \cdot pf_2 = 60 \text{ kVA} \cdot 0.82 = 49.0 \text{ kW}$

6. Summary, rules, recommendations:

it is often economically not justifiable to compensate 100% and reach an exact pf of one. A reasonable value is 0.8 - 0.9.

to compensate 1 kVAr in a single phase 220V/ 50 Hz network, the value of the capacitor has to be 66 mF (micro Farad).

to compensate 1 kVAr in a three phase 380V/ 50 Hz network, the value of the capacitor has to be 22 pF per phase.

to order or buy a capacitor it is normally enough to indicate the reactive power to be compensated as well as the supply voltage.

supplying institutions often set rules for the compensation of (induction) motors. For instance fixing the Q to be compensated to 40 45 % of the motor's nominal (active) power which determines the value of C.





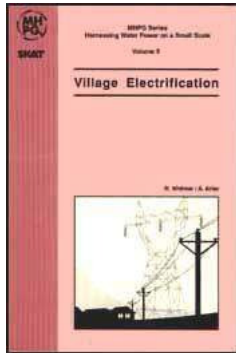



[Home](#) > [ar.cn.de.en.es.fr.id.it.ph.po.ru.sw](#)



Village Electrification (SKAT, 1992, 128 p.)

Part 5: Earthing

(introduction...)

-  1. Current flow in the ground
-  2. The specific electrical resistance of the ground
-  3. Measurement of the earth resistance
-  4. The Influence of the dig-in depth
-  5. Earth contacts
-  6. The influence of current on the earth resistance

Village Electrification (SKAT, 1992, 128 p.)

Part 5: Earthing

Earthing is a continuous headache in power distribution systems, especially in small or medium grids with considerable power, several consumer groups and transformers to distribute electrical energy at different voltages. If there are no exact rules, which are strictly applied, such grids tend to deteriorate. For instance electrical current starts to leak to the earth through defect insulations, fuses will not trip due to missing or inadequate earthing and three phase systems run out of balance. Not only can the power losses raise

to uneconomic heights (one third have been reported in Nepal), but also people, animals and equipment are exposed to danger by this uncontrolled current flow.

The soil is a conductor, not a very good one, but good enough to be both a cheap substitute for wires (see part Distribution Systems, SWER) and a dangerous source for electrical shocks. To understand the connections and find remedies, we need a basic insight in the conduction of current in the ground.

1. Current flow in the ground

Contrary to wires, current will spread out when injected in the ground, 'thinning out' quickly at a growing distance from the injection point. This 'thinning' of the current has the following effect: although the specific resistance of soil is generally rather high, the growing cross-section of the current flow reduces the resistance continuously.

It is important to understand the relation and differences between specific resistance p , the resistance R and the resistance distribution $R(r)$. The first two are proportional, where R is the specific resistance multiplied by a geometry factor, e.g. in case of a cubic conductor the length l divided by the cross-section A . R is determined by Ohms law ($R = U/I$), which is well defined for lumped circuits. In our case, however, the current spreads out, the resistor(the ground) has only one contact (the earth contact) so the voltage U is not simple to determine, and we need a more subtle way to define the earth resistance.

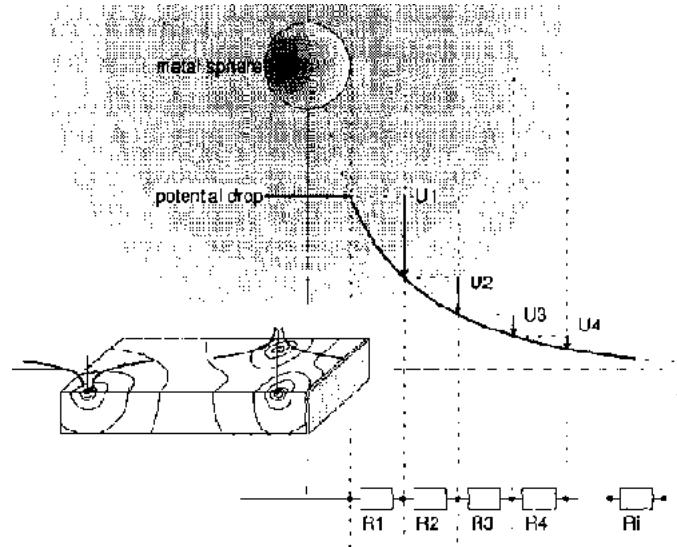

Fig 1 Current and Potential Distribution in a homogeneous material and an approximation of the earth resistance with lumped resistors.

The resistance distribution $it(r)$ is adequate. It is defined like Ohms law: $it(r) = U(r)II$, but takes into consideration that the resistance varies with the distance r from the earth contact.

Suppose a ground consists of some homogeneous material and has a constant specific resistance. The earth contact, a metallic sphere, is deeply dug in. Note: A spherical earth contact of course is not a practical form, but due to its perfect symmetric it is easy to derive some understanding and basic formulas. The current will enter this soil radially. The resistance distribution can be seen as made of a series of concentric spherical shells with constant thickness Dr . The surface A of these shells grows quickly with increasing

distance from the injection point. So the contribution of each following shell to the total resistance diminishes quickly. The resistance distribution will rise steeply and approaches a constant value at some distance away from the earth contact. This resistance to 'infinity' is defined as the earth resistance R_E .

The previous considerations can be expressed in mathematical terms.

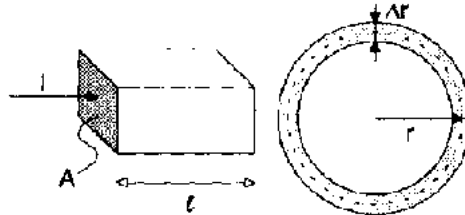

$$\begin{aligned} \text{a) } R &= \rho \cdot \frac{l}{A} & \text{b) } R &= \rho \cdot \frac{\Delta r}{4\pi r} \\ \text{with } l &= \Delta r \text{ and } A = 4\pi r^2 & & \quad (1) \end{aligned}$$

Fig 2 a) resistance of a cube; b) resistance of a sphere, this value is only exact for very small shell thicknesses Δr !

approximation with spherical shells

$$\Delta R_i = \frac{\rho}{4\pi} \cdot \frac{\Delta r}{r_i^2}$$

$$R(r_N) = \sum_{i=1}^N \Delta R_i = \frac{\rho}{4\pi} \sum_{i=1}^N \frac{\Delta r}{r_i^2}$$

$$\text{with } r_i = r_0 + i \cdot \Delta r$$

exact calculation

$$dR = \frac{\rho}{4\pi} \cdot \frac{dr}{r^2}$$

$$R(r) = \frac{\rho}{4\pi} \int_{r_0}^r \frac{dr'}{r'^2} = \frac{\rho}{4\pi} \left(\frac{1}{r_0} - \frac{1}{r} \right) \quad (2)$$

$$R(r)|_{r \rightarrow \infty} = \frac{\rho}{4 \cdot \pi} \cdot \frac{1}{r_0}$$

Formula 2 Calculations of the earth resistance (see also Fig 1&2) for a hypothetical spherical earth contact. Once calculated as an approximation (series resistance of thin

shells) and the exact calculation with an integral.

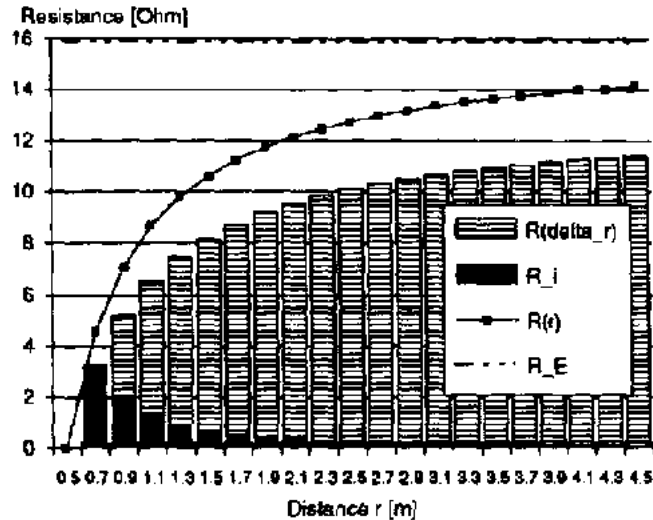
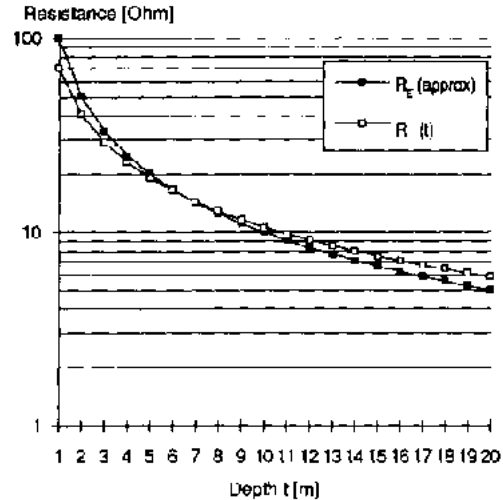

Fig 3 The development of the earth resistance R_E W with growing distance from the center of a metal sphere of 0.5m diameter. ($d = 100$ Wm). It shows a) the decreasing resistance of 20cm thick 'soil shells' (see fig1 and 2), b) the stabilizing earth resistance, c) the exact calculation and d) the value at infinity.

Another simple earth contact is a steel rod or stick (normally a galvanized pipe). Its theoretical earth resistance is given in formula 3, Fig 5. The major advantage is the simple installation (no digging is needed) and the possibility to reach better conducting soil strata in some depth.



$$R_E(t, d) = \frac{\rho}{2 \cdot \pi} \cdot \frac{1}{t} \cdot \ln\left(\frac{4t}{d}\right)$$

$$R_{E \text{ approx}}(t) = \frac{\rho}{t} \quad \{3\}$$

Fig 5 Earth resistance for a stick earth contact. Here t is the length of the stick and d its diameter.

We find two important conclusions:

**The earth resistance R_E grows to infinity if the earth contact surface becomes very small -
 > always maximize the earth contact surface and the injected current produces a voltage**

drop proportional to the resistance $i(r)$ around the earth contact, hence is a function of the distance from the earth contact -> the voltage changes (drops or rises) quickly close to the earth contact and stabilizes far away towards the neutral earth potential.

According to the shape of the relation 'voltage versus distance' this effect is called the potential funnel (or potential well, potential trough).

To transmit electrical energy through the ground, we are only interested in a small voltage drop at the earth contact (apply the first conclusion). For protection, however, we have to consider the shape of the potential funnel too.

Is the potential varying strongly at short ranges, it is possible to have dangerous voltages (this is the same as potential differences) over let's say one meter distance. These voltages are called step and contact voltage. Simply making a step or touching two things a short distance apart might cause death. For instance animals and people dying through lightning during thunderstorms are normally not directly struck, but get lethal voltages in the potential funnel of a nearby hitting lightning!

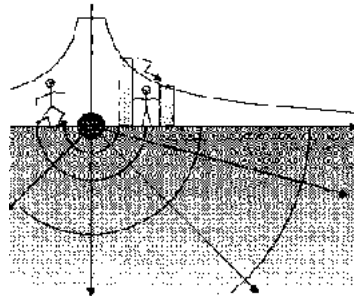

Fig 6 Step and contact voltage in a potential funnel

Besides reaching low earth resistances, it is needed to shape the potential funnel to avoid

accidents!

2. The specific electrical resistance of the ground

The specific resistance ρ of the soil is one of the key parameters for the resistance of an earth contact. It is a function of the chemical composition, the humidity and the temperature and may vary widely. The specific resistance is given in Ohm meter [Wm]. Extensive research in Switzerland has revealed the following relations:

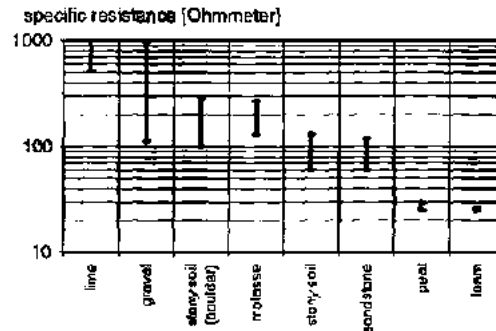

Fig 7 Specific resistance for different types of soil.

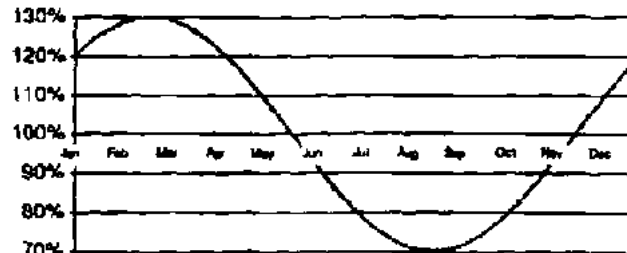

Fig 8 Relative variation of the specific resistance ρ as a function of season.

Soil has a negative temperature coefficient of about $\alpha = 0.023 - 0.037$, so the resistance inversely follows the temperature, showing a marked maximum in winter and minimum in summer (European climate!).

Also the water content of soil changes the specific resistivity. Generally the higher the content the lower the resistance, so any measurements to determine the earth resistance should take place only days after heavy rains, not during monsoon or at high ground water level. Frost increases the resistance considerably, so dig-in-the-earth contact is recommended for such zones.

3. Measurement of the earth resistance

To measure the specific earth resistance, special measurement tools are available. Their basic principle is to inject through two probes a current into the ground and to sense with another one (or two) probe(s) the potential at the surface.

This is very much the same approach as is used to determine the resistance distribution of the earth contact, so we will briefly explain this first.

The normal tool for the measurement is a bridge (see Fig 9). An AC current, produced by a hand-driven generator, is injected through the earth contact (1) and the auxiliary probe (2) (the distance between these two should not be less than 20 to 40m to ensure the auxiliary probe to be outside of the potential funnel). An identical current, produced with a 1:1 current transformer, is passing through the internal resistor R.

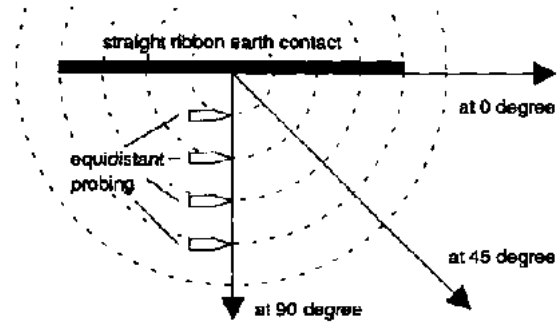
**FIGURE**

distance (m)	Resist. Distrib. $R(r)$	
	measured [Ω]	relative [%]
0.0	5.4	30%
0.5	5.8	32%
1.0	6.7	37%
1.5	8.1	45%
2.0	9.9	55%
3.0	13.1	73%
4.0	14.7	82%
6.0	16.3	91%
8.0	18.7	93%
∞	18.0	100%

TABLE

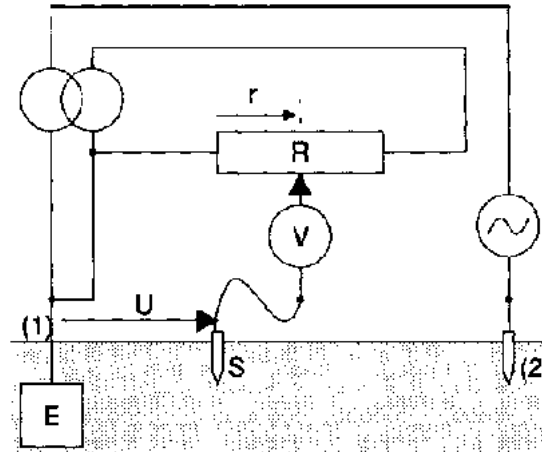

Fig 9 Bridge method to measure the resistance distribution in the ground and to determine the potential at the surface.

The sensing probe S is placed at the position where we need to know the voltage drop/resistance. The variable resistor r is adjusted until the bridge is balanced ($V = 0$). Now the variable resistor equals the resistance distribution at S and the Voltage U equals the voltage drop to the earth contact. One major advantage of this method is the currentless sensing probe. With no measuring current in (S) in the balanced bridge, no distortion of the results will happen.

To know the potential funnel around an earth contact, several measurements are made along straight lines at pre-fixed distances. It is convenient to indicate the relative resistance along the measuring direction (e.g. $it(r)$ relative to $R(\text{¥})$, the resistance very far away or the earth resistance R_E) The plot ' $R(r)$ [%] versus distance' is proportional to the earth potential U [%] and the step and contact voltage (U_s & U_c respectively) are easily

extracted.

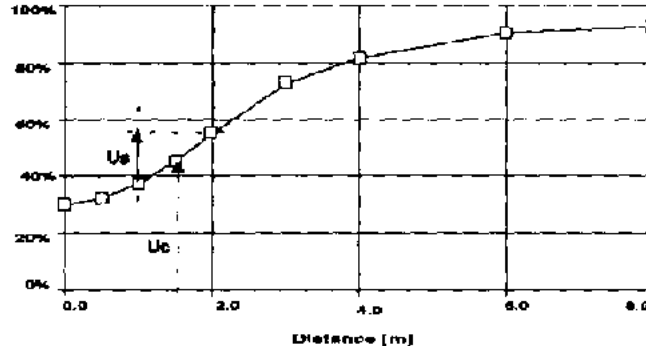

Fig 10 Measuring principle to collect a potential distribution at the surface for a ribbon earth contact (Cu 30/3mm x 4m; depth 0.2m).

U_c is the voltage between the earth contact and the ground surface (contact voltage). U_s is the step voltage between two neighboring points 1 m apart. The maximum of U_s is at the place where the resistance curve is at the steepest.

The specific resistance d of the soil is proportional to the resistance measured above. The proportionality factor depends on the geometry of the earth contact and the probes and is given in tables.

4. The Influence of the dig-in depth

The depth and earth contact is dug-in and influences the earth resistance. Norm ally the less it IS covered by soil the higher and steeper the potential funnel is.

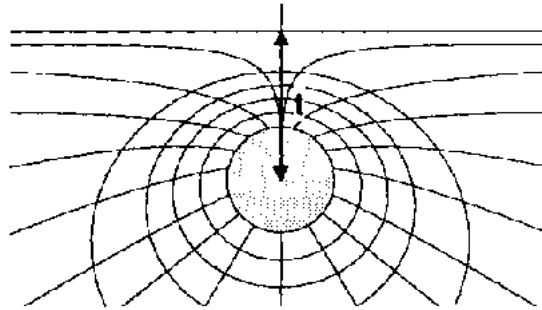

$$R_E(t) = \frac{\rho}{4 \cdot \pi} \cdot \frac{1}{r_0} \cdot \left(1 + \frac{r_0}{2t} \right) \quad (4)$$

Fig 11 Influence of the dig-in depth on the earth resistance.

The closer the surface, the higher the resistance. For $t = \frac{r_0}{2}$ the value is the same as in the previous formula.

A rod or stick earth contact is even more sensitive to the depth it is driven in.

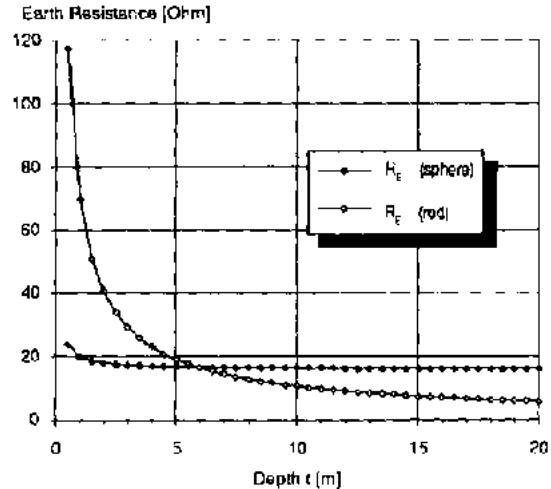

Fig 12 Comparison of the earth resistance of a sphere and stick earth contact as a function of the depth t .

The calculation is done according to the above formulas {3} and {4}. The sphere diameter r_0 is 0.5m, the rod diameter is 0.05m and p is 100 Qm.

By varying the dig-in depth, we can also widely vary the shape of the resistance curve and so shape the step and contact voltages of any earth contact.

If the earth contact reaches the surface, the contact voltage is very low, but the distribution is steep and consequently the step voltage high. Digging in the earth contact deeply smooths the distribution, lowers the step voltage, but increases the contact voltage.

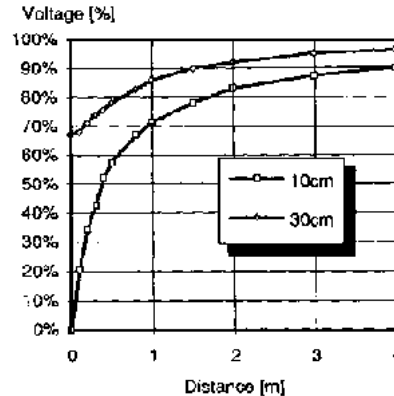

Fig 13 Resistance (voltage) distribution at the surface in case of a vertically dug-in plate t5(500/500mm) at two different depths.

To avoid distortions, the electrical connections are done with isolated cables.

5. Earth contacts

It is useful to distinguish between two types of earth contacts, the artificial and the natural earth contacts: the first is especially designed and installed, the latter is already existing, conducting structures like water supplies, cables and foundations.

5.1. Artificial Earth Contacts

Formerly metal sheets were used, but nowadays metal ribbons are standard. They are readily available, easy to transport and very flexible in installation.

There are three prominent forms to dig them in: straight, as a ring or a cross. Other forms are of course possible. The first might be the simplest and during construction any

adequate straight ditch could be used. With the second it is easily possible to adjust the shape of the potential funnel around the earth contact by digging in several different ribbon rings, varying their dimensions and dig-in depth and connect them in parallel. The last is adequate for high impulse voltages (lightning), as under this condition the earth resistance increases considerably due to high frequency components.

If there is a better conducting strata at some depth, stick earth contact can be used. They offer also under 'normal' conditions several advantages: no digging necessary stable resistance top pan is easy to insulate to decrease step voltage

Zinc coated steel tubes are simply driven in with a (motor driven) hammer. Several tubes can be connected in series to reach the necessary length.

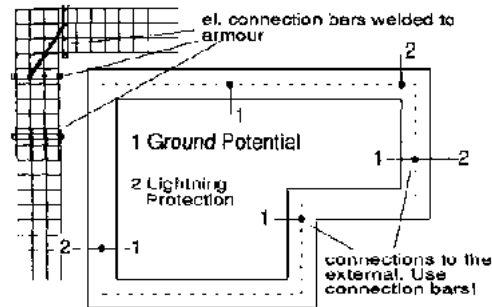

Fig 14 Using the reinforcement steel matt as earth contact.

5.2. Natural Earth Contacts

The most common natural earth contact is the water supply system, as soon as it reaches extensions of several hundred meters. The earth resistance might then be as low as 0.5 W. In modem water supply grids, however, the pipes or their connections might be made of

PE or similar plastic materials. In this case the water supply grid cannot be used. If available, the armour of any dug-in cable could be used as a substitute. It is important not to exceed current densities of 10A/mm² in lead armours for more than 0.5 seconds to avoid dangerous temperature increases. In modern earthing systems, the armour steel of reinforced concrete foundations is always used as earth contact. The steel needs a cross-section of at least 50 mm² per bar. Longitudinal bars are electrically connected as well as junctions, corners and dilatation gaps. Contacts for potential equalization and lightning protection have to be provided. Even if no reinforced concrete is used, the foundation can be used as an earth contact. In this case a steel wire (100 mm²) or a steel ribbon is integrated into the foundation.

5.3. Contact Materials

The chemical disintegration of the earth contact is a complicated process. The dug in material is corroding by itself. Then it is electrically connected to other materials, which together with some electrolyte (the soil) form a battery and destroy the earth contact. This effect can be accentuated by stray DC currents in the soil or DC components in the earth current. Tests have shown that materials like stainless steel and lead are not reliable. Galvanized (zinc coated) iron ribbons are useful except in connection with for instance copper, but also ungalvanized steel constructions, cast iron and concrete Armour can quickly destroy the zinc layer. Avoiding thicknesses below 2.5 mm still ascertains a life-span of several decades. Copper is an excellent but expensive alternative, however, it is aggressively corroding less precious metals in the same earth circuit.

6. The influence of current on the earth resistance

Any current injected into the soil will cause an increase of the temperature due to the earth resistance. Close to the earth contact this temperature might change considerably as the resistance peaks at the earth contact surface. As we have seen before, the temperature

coefficient of the earth resistance is negative, and in the first moment the resistance will drop (about 10-15%). If the heat produced is not able to dissipate into the soil, the earth might reach temperatures of 100°C and all water starts to evaporate. Soon the soil will be completely dry and the earth resistance will rise abruptly ten to twenty fold. To avoid any such problems it is advisable to keep the power dissipation below 5 kW per square meter earth contact surface.

