

# FAO ANIMAL PRODUCTION AND HEALTH PAPER 79

## Manual on simple methods of meat preservation

[Contents](#)

---

**The designations employed and the presentation of material in this publication do not imply the expression of any opinion whatsoever on the part of the Food and Agriculture Organization of the United Nations concerning the legal status of any country, territory, city or area or of its authorities, or concerning the delimitation of its frontiers or boundaries.**

**M-25**  
**ISBN 92-5-102744-7**

**All rights reserved. No part of this publication may be reproduced, stored in a retrieval system, or transmitted in any form or by any means, electronic, mechanical, photocopying or otherwise, without the prior permission of the copyright owner. Applications for such**

**permission, with a statement of the purpose and extent of the reproduction, should be addressed to the Director, Publications Division, Food and Agriculture Organization of the United Nations, Via delle Terme di Caracalla, 00100 Rome, Italy.**

**FOOD AND AGRICULTURE ORGANIZATION OF THE UNITED  
NATIONS Rome, 1990  
© FAO 1990**

---

**Hyperlinks to non-FAO Internet sites do not imply any official endorsement of or responsibility for the opinions, ideas, data or**

**products presented at these locations, or guarantee the validity of the information provided. The sole purpose of links to non-FAO sites is to indicate further information available on related topics.**

## **Contents**

### **Introduction**

### **1. Slaughtering and raw materials for meat preservation**

### **2. Simple techniques for production of dried meat**

### **3. Meat preservation by thermal treatment**

### **4. Impact of packaging methods on meat preservation**

### **5. Basic methods of quality control**

### **Table 1. Pistola system, primal cuts expressed in percentage of cold**

## **carcass weight**

**Table 2. F-values corresponding to various temperatures**

**Table 3. F-values in relation to temperature and time**

**Table 4. Decimal reduction rates during heat treatment**

**Table 5. Recommended thermal treatment for selected products**

## **Illustrations**

**Figure 1 Simple wooden structure to hoist slaughter animal after bleeding**

**Figure 2 Removal of skin from the hanging carcass**

**Figure 3 Layout of the FAO small-scale modular slaughterhouse**

**Figure 4 Beef carcass showing primal cuts according to pistola procedure**

**Figure 5 Hindquarter (top) and forequarter (bottom) separated behind the last rib. (Procedure recommended for meat for drying)**

**Figure 6 Dehydration process of a piece of meat suspended under drying conditions (schematic)**

**Figure 7 Trimming a beef carcass**

**Figure 8 Suspended anatomic cut from the hindquarters (“silverside”) (A) and splitting into individual muscles (B) which result in (C)**

**Figure 9 Cutting meat strips from the muscle on a chopping board**

**Figure 10 Cutting meat strips from a suspended muscle**

**Figure 11 Special cutting technique to obtain long meat strips**

**Figure 12 Meat strips are soaked in a 14-percent salt solution for five minutes**

**Figure 13 Draining the brine from the meat strips after soaking using a plastic sieve**

**Figure 14 Suspension of meat strips on hooks (A), loops (B) and by means of clips (C)**

**Figure 15 Preparing hooks from galvanized wire**

**Figure 16 Preparing loops from string or thread and fixing the meat strips**

**Figure 17 Simple wooden construction for meat drying using sticks (A) or wire/plastic rope (B) to suspend the meat strips**

**Figure 18 Simple metal construction for meat drying using sticks (A) or wire/plastic rope (B) to suspend the meat strips**

**Figure 19 Movable metal construction for meat drying**

**Figure 20 Suspending meat strips on the lower level of the dryer on**



**wooden sticks by means of metal hooks**

**Figure 21 Roofed meat dryer (corrugated aluminium)**

**Figure 22 Protecting the sides of a meat dryer with an insect screen**

**Figure 23 Arranging meat strips in the dryer along sticks or wires for suspension**

**Figure 24 Dried meat strips**

**Figure 25 Properly dried meat with a smooth surface and uniform cross-section**

**Figure 26 Dried meat strips packed in plastic bags with the opening heat sealed (above) or tied (below)**

**Figure 27 Dried meat in jute sacks for wholesale trade**

**Figure 28 Whole strips and flat pieces of dried meat and dried meat**

**comminuted to fragments of different sizes for preparing meals**

**Figure 29 Preparing a meal of dried meat. As a first step the dried meat is put into boiling water**

**Figure 30 Retort cooker**

**Figure 31 Principles of can-seaming operation**

**Figure 32 Vacuum chamber machine**

**Figure 33 Electrical thermometer with digital display and two sensors, for measuring air temperature (left) and the temperature of meat, liquids, etc. (right)**

**Figure 34 Electronic psychrometer (hygrometer) and sensor (right) for direct measurement of the relative air humidity**

**Figure 35 Mechanical instrument to prove airtight closure of cans**

**Figure 36 Portable electric pH-meter with sensor (glass electrode)**

**Figure 37 Trigger and sterile cellotape for microbiological sampling of the meat surface**

**Figure 38 Culture medium with various fields after incubation of different samples taken using the technique shown in Fig.37**

**Figure 39 Sampling microbial contamination on a defined surface area marked by sterile template with sterile swabs**

**Figure 40 Transfer of the sample taken with the swab on to the surface of the culture medium.**

**Figure 41 Bacterial colonies grown from one cell each on the culture medium after the incubation period.**

## **Introduction**

**Although the demand in developing countries for animal proteins**

**is increasing, animal production has failed to keep pace with the growth in demand and to make full use of its potential in developing countries.**

**The nutrition of resource-poor rural producers can be improved both directly by consumption of animal food products or indirectly by enabling the purchase of food with returns from animal product sales.**

**The average per caput supply of meat in developing countries is very low. In 1979 and 1986 it amounted to 12.7 and 15.4 kg/caput/year respectively as compared to the developed countries with 74.3 and 77.9 kg/caput/ year respectively. The average per caput supply in developing countries in Africa reached the average level of all developing countries in 1979 with 12.9 kg/caput/ year but in 1986 remained at 11.8 kg/caput/year, below the level of the developing countries combined and even below the 1979 level.**

**While efforts are increasing to support animal production in developing countries, they are not matched by similar efforts to use preservation to overcome seasonal variation in meat supply. In addition the existing conditions for slaughtering and meat handling in rural areas which cause quality deterioration and post-harvest losses of meat- and food-borne diseases in consumers must be improved.**

**In fact there is a lack of effort to provide knowledge and skills in adequate hygienic slaughtering, meat cutting and handling under rural conditions. Taking into account that an uninterrupted cold chain for meat cannot be expected in many developing countries in the near future, the absence of meat preservation techniques presents a serious constraint to the development of viable meat production by resource-poor rural livestock producers.**

**Adequate meat preservation complements a marketing system which by necessity has been adapted to a fast throughput of**

**fresh meat and which does not facilitate the use of surplus meat in periods of meat shortage.**

**While this publication is mainly intended to disseminate information on traditional methods of meat preservation in Africa for teachers and instructors, it also addresses aspects of hygienic slaughtering under rural conditions. Reference is also made to FAO's work on small-scale slaughterhouses, raw materials for preserved meat, principles of meat preservation by thermal treatment, packaging methods and basic methods of quality control.**



---

## **1. Slaughtering and raw materials for meat preservation**

**Product quality and shelf-life of preserved meat and meat**

**products depend on the microbiological and biochemical status of the carcass meat used for processing. In other words, the raw material must be as clean as possible and derived from slaughter animals in good and healthy condition.**

**Obviously the way of slaughtering animals plays an important role. Many irreversible quality losses, especially with regard to the hygienic quality, originate from improper slaughtering and carcass handling. Slaughter techniques, particularly under rural conditions, cannot and need not be sophisticated, but they must allow carcass meat which complies with basic hygienic requirements to be obtained whether slaughtering at the farm, or in slaughterlabs or slaughterhouses.**

**Careless slaughter and meat handling result in:**

- improper and insufficient bleeding of the animals, leaving a relatively high amount of blood in the muscle. As a**

**consequence the meat does not reach the necessary degree of acidity and its shelf-life is reduced;**

- **improper dehiding of the carcass, leading to heavy contamination of the meat surfaces by frequent contact with the personnel, polluted floors and dirty tools and equipment;**
- **improper evisceration through accidental opening of stomachs and tripes, leading to contamination spreading to internal and external surfaces of the carcass;**
- **contamination of the meat when carcasses are split on the ground;**
- **contamination of the meat during transport, when carcasses or parts of them make contact with unclean clothes, hooks, bars or containers;**
- **contamination of the meat stored under unhygienic conditions and because of faulty handling in meat markets, shops and processing plants.**

**It has to be borne in mind that faulty meat handling, apart from**



**affecting the quality and shelf-life of meat and processed products, may also endanger the health of consumers. Massive contamination will not only enhance meat deterioration caused by food-spoiling bacteria, but may also cause poisoning of consumers by toxin-producing micro-organisms. Toxin-producing micro-organisms find a favourable environment not only in fresh meat stored for a prolonged period at ambient temperatures, but also under certain circumstances in processed meat or even in preserved meat. Appropriate hygienic measures during slaughtering and meat handling are therefore indispensable.**

**A proper way of improving the slaughter hygiene is to carry out as much of the slaughter operations as possible with the carcass in a hanging position.**

## **RURAL SLAUGHTERING ON THE FARM**

**Slaughter operations of small animals can easily be performed with the carcass in a hanging position. Problems may arise when slaughtering large animals such as cattle. The bleeding of the animal and cutting off the hind feet is done on the ground and the opening of the skin of the belly and leg region may also have to be done in this position. To complete skinning, evisceration and splitting, simple wooden structures and ropes to gradually hoist up the carcass are strongly recommended (see Figs 1 and 2).**

**Remarkable improvements in slaughter hygiene can be achieved by this technique with much less visible contamination (dirt) and a lower degree of invisible contamination. The structure built for slaughtering can also be used for cutting and deboning the carcass.**

## **SLAUGHTERSLABS**

**Slaughterslabs are used in rural communities where the throughput of animals is very small, but where slaughtering in the field should be avoided.**

**Animals should be suspended from a wooden or metal frame using a gantry hoist to ensure that carcasses are kept off the floor.**

**The simplest slaughterslab consists of a concrete platform with gantryhoist facilities. The platform should be approximately 50 cm above the ground and sloped to a drain. A roof should be added as protection against adverse weather conditions.**

**Slaughterslabs should be fenced and roofed and have facilities for hygienic slaughtering and adequate disposal of effluents. If pigs are to be killed a scalding vat should be provided.**

## **FAO'S SMALL-SCALE MODULAR SLAUGHTERHOUSE**

**The Animal Production and Health Division of the Food and Agriculture Organization of the United Nations (FAO) has developed a model project for village meat industry in which one of the main components is a smallscale modular slaughterhouse. The design incorporates the use of locally available construction materials and unsophisticated equipment. The slaughterhouse can be built in modules, adding units to the central slaughterhall for operations such as by-product utilization, meat preservation, processing and butchering. Designs have also been prepared for the construction of a meat market in order to facilitate the integration of production, processing and marketing.**

**FIG. 1.**

**Simple wooden structure to hoist slaughter animal after bleeding.**



**FIG. 2.**  
**Removal of skin from the hanging carcass.**



**It is intended that from the basic nucleus a number of small-scale industries be developed consecutively, e.g. meat preservation by low-cost technologies, traditional tanning, handicrafts based on hides, skin, bone and horns, etc. The objective is to increase employment, in particular for rural women, create market outlets for livestock products and increase the income of small producers.**

**The project could become a focus for farmer organization and a centre of technical assistance for producers. The organization of small producers is indispensable to ensure their participation and for the success and continuity of the project.**

**FAO is promoting the establishment of slaughterhouses of this type in some rural areas because this would increase the availability and quality of meat, improve the utilization of by-products, avoid rural migration and increase employment. The slaughterhouses may, therefore, constitute a tool for rural**

**development, increasing the income level in the countryside and villages, thus improving the living conditions of the rural communities.**

**Rural slaughterhouses can also facilitate veterinary control of livestock (ante-mortem inspection) and carcass meat (post-mortem inspection). Slaughtering can be organized to follow a determined daily or weekly time schedule for which compulsory veterinary controls can be arranged. In addition, adequate technical facilities for efficient meat inspection can be provided, i.e. vertical position of the carcasses and special platforms for the personnel. Special hooks or inspection tables can be provided for the inspection of internal organs.**

**The detailed design for a small-scale modular slaughterhouse was developed by FAO. It includes designs, specifications, and schedule of quantities for a slaughterhouse and meat market suitable for small communities.**



**Provision is made for slaughter of all species: cattle (or buffalo), sheep, goats and pigs, though because of space limitations, concurrent slaughter of**

**different species is not possible. The abattoir capacity will be dependent on the mix of animals being slaughtered. Daily throughputs of approximately 10 large stock (e.g. cattle) or 50 small stock (sheep, goats or pigs) or a combination thereof could be achieved with this design.**

**The facilities are divided into modules which can be combined as required to suit a particular location.**

**The following modules are included:**

- **Lairage**
- **Slaughter floor**
- **Chiller**

- **Tripe room**
- **Meat cutting and processing room**
- **Solid waste and blood disposal**
- **Hides and skin processing**
- **Effluent disposal**
- **Electric light and power**
- **Water supply**
- **Meat market**

**A possible overall abattoir layout based on these modules is shown in Fig. 3. This layout shows a typical arrangement for a facility designed to handle beef, small ruminants and pigs. Modifications for a large beef kill and/or the elimination of pig slaughter (e.g. for Muslim communities) are possible.**

**It is evident that when establishing slaughterhouses each country or even separate localities must adopt a solution incorporating special local conditions, locally available materials**

**and manpower, etc.**

**The designs foresee procedures for slaughter of each species as follows:**

### **Cattle**

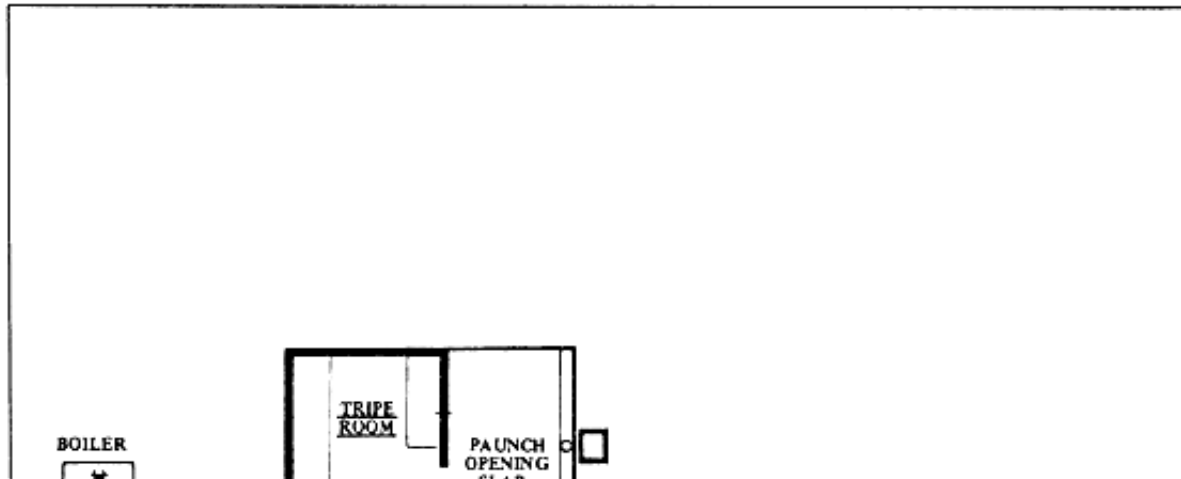
**The animal is led into the bleeding area where it is restrained by a tether through the floor ring prior to stunning (using a captive bolt pistol). After stunning the animal is shackled by one leg and hoisted with a rope pulley block. The animal is then stuck and allowed to bleed in this position and the blood collected in a drum for disposal.**

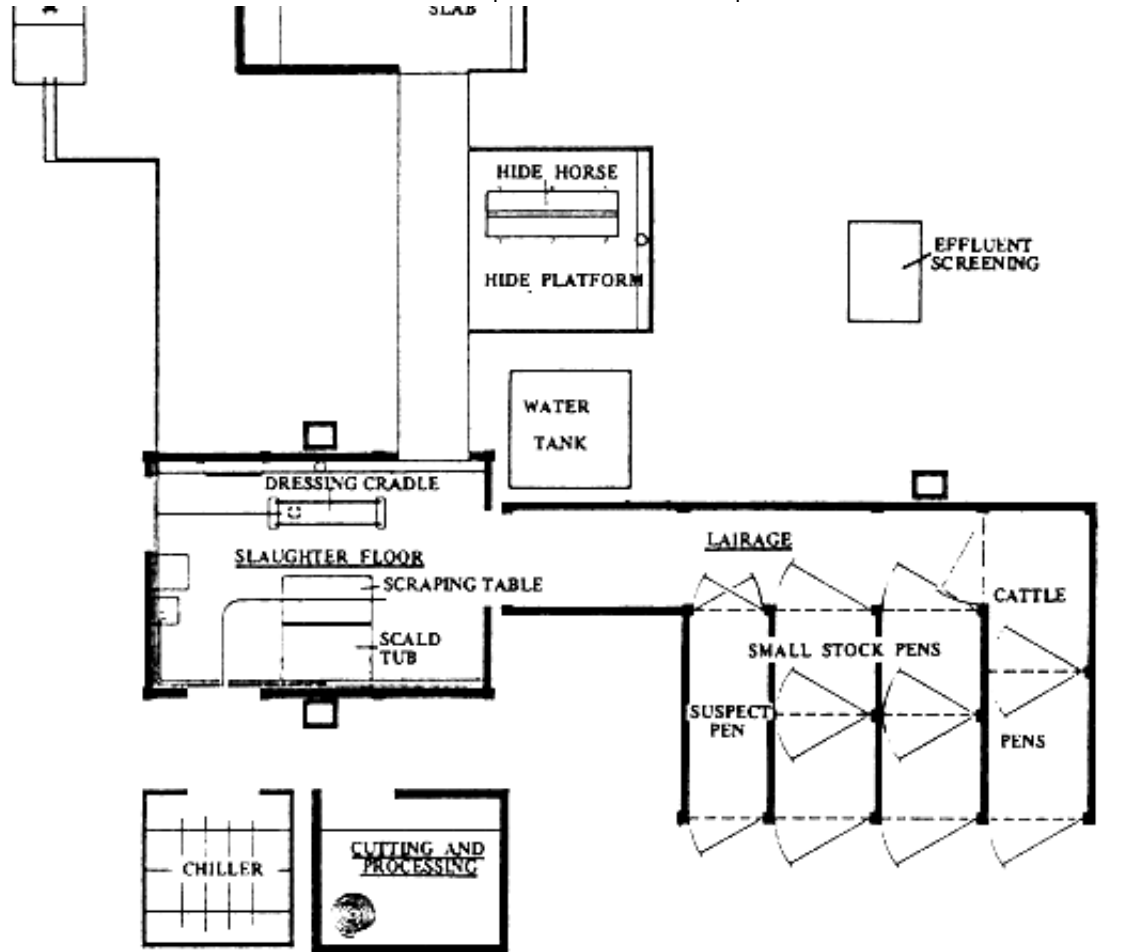
**Once bleeding is complete the head can be removed and the animal lowered on to the cradle for dressing. It is also possible to dress the hanging animal. The feet are then removed, the skin opened up along the breastbone and the hide partially flayed.**

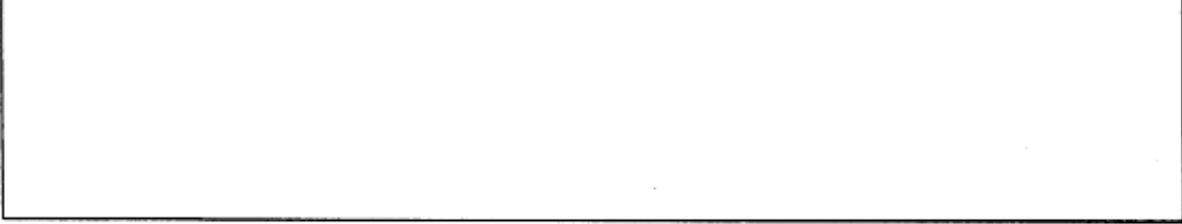
**Leg hooks are attached and the carcass raised to a half-hoist position on the spreader. Flaying can then be completed and the hide removed. The paunch can then be removed to the inspection buggy and the red offal (including lungs if treated as edible) placed on hooks or the inspection table for inspection.**

**FIG 3.**

**Layout of the FAO small-scale modular slaughterhouse.**







**After inspection the carcass can be split and quartered, the quarters being individually hung on the low rail.**

**Once the carcass has been partially flayed and half-hoisted a second animal can enter the bleeding area.**

## **Pigs**

**Pigs are first stunned in the stunning area then hoisted for sticking and bleeding and then transferred to the scald tank. After scalding for approximately five minutes at 60°C the carcass is removed to the scraping table. After scraping a gambrel can be inserted into the hind legs and the carcass transferred to the**

**overhead rail for final scraping and evisceration. Once a pig is clear of the scraping table the next pig can be placed in the scalding tub.**

## **Sheep and goats**

**These would be slaughtered and dressed on the rail in the pig area in a similar manner to pigs. The scraping table is removed to one side during processing of sheep and goats.**

## **CARCASS HANDLING**

**After slaughter carcasses should be chilled in chilling rooms. Chilled meat is a requirement for many methods of further processing. However, in rural areas of developing countries refrigeration facilities are generally lacking. Before cutting, carcasses should therefore be carefully examined for signs of taint caused by microbial spoilage.**

**Unchilled meat as a raw material is suitable for dried meat and certain meat products which undergo a heat treatment immediately after processing.**

**When dealing with hot carcasses, cuts and trimmings should be either consumed or processed (dried) on the day of slaughtering. It is obvious that under these conditions good hygiene during slaughtering and meat handling is of great importance for the quality of the final product. The higher the initial contamination, the faster the meat deterioration, especially under high ambiental temperatures.**

**In this context a new way of short-term meat preservation that could be especially beneficial for prolonged periods of handling of carcasses or meat cuts during transport, etc. should be mentioned. Meat surfaces are treated with organic acids such as acetic, lactic, citric, tartaric and ascorbic acid, as well as sodium sorbate. These compounds are from different natural foods and**



**not toxic and may be used alone or in combination as dipping solutions or sprays on the surface of meat and meat products. Treatment of carcasses with these products has proved to be successful under conditions in developing countries. With an aqueous solution of 20 percent sodium sorbate, 5 percent sodium acetate and 5 percent sodium chloride sprayed on warm beef carcasses, the shelf-life of meat at 25° to 35°C was doubled. However, more work is needed on the subject, especially for tropical conditions.**

## **CUTTING**

**As whole carcasses of beef or pork are too large to be easily transported in one piece, they are split into sides or cut into fore- and hindquarters. The development of meat processing introduced the need for cutting quarters, halves or whole carcasses into smaller pieces which, according to their quality and market value, are used for culinary purposes and processing**

**respectively.**

**The culinary meat in the form of primary cut is mostly sold to wholesale dealers who bone and cut it into sub-primals and finally into retail cut. The point at which wholesale cutting ends and retail cutting begins is not clearly defined. In the traditional, small, independent butchers' shops these operations may take place on a cutting table behind the counter in order to give the butcher the maximum opportunity to select the most suitable piece of meat and prepare it in a manner which is most likely to satisfy the consumer.**

**Meat for processing comprises parts of lower quality but also high-quality meat for the manufacture of special products like hams, smoked pork loins and dried meat. It can be divided into different classes according to the amount of fat and connective tissues.**

**There are several regional, country, and local differences in cutting the animal carcass into primary or retail cut and butchery practices vary depending on geographical location, tradition and habits, and demand for high-quality meat.**

**For the preparation of dried meat, two methods have been recommended. In both, carcasses are divided into two sides along the backbone. Each side is cut crosswise into two quarters which are divided into primal and retail cuts, and then boned and trimmed.**

**The pistola cutting system, with the side of beef quartered between the fifth and sixth ribs, allows the complete separation of all first-quality meat cuts in the hindquarters and loin regions. Fig. 4 illustrates primal cuts in the beef carcass.**

**After separation of the forequarters, the flank piece is removed by freeing the muscles of the abdomen from those of the**

**proximal pelvic limb. Separation is completed by extending the cut down the side, parallel to and at a distance of some 20 cm from the backbone.**

**The hindquarter piece, which contains all the first-quality muscles, may be separated into the hind leg, rump and loin cuts by cutting and sawing directly across the *Bicepsfemoris* at a point just below the exposed point of the pelvic bone. The forequarter is similarly divided into two by removing the foreleg and blade cut from the thorax and neck. Table 1 illustrates the distribution of primal cuts within the carcass.**

**According to the second method the carcass is split into sides, along the spinal column. After that, the sides are cut horizontally into two quarters: hindquarters and forequarters. The cut line runs immediately after the last rib, which excludes leaving any ribs on the hindquarters. The hindquarters are hooked by the Achilles tendon and the forequarters by the last two ribs (Fig. 5).**

**In both cutting systems further division into commercial or retail cuts is usually necessary in order to separate the muscles or groups of muscles most suitable for drying from those which, by nature of their characteristics and retail value, should be sold fresh or processed by other methods.**

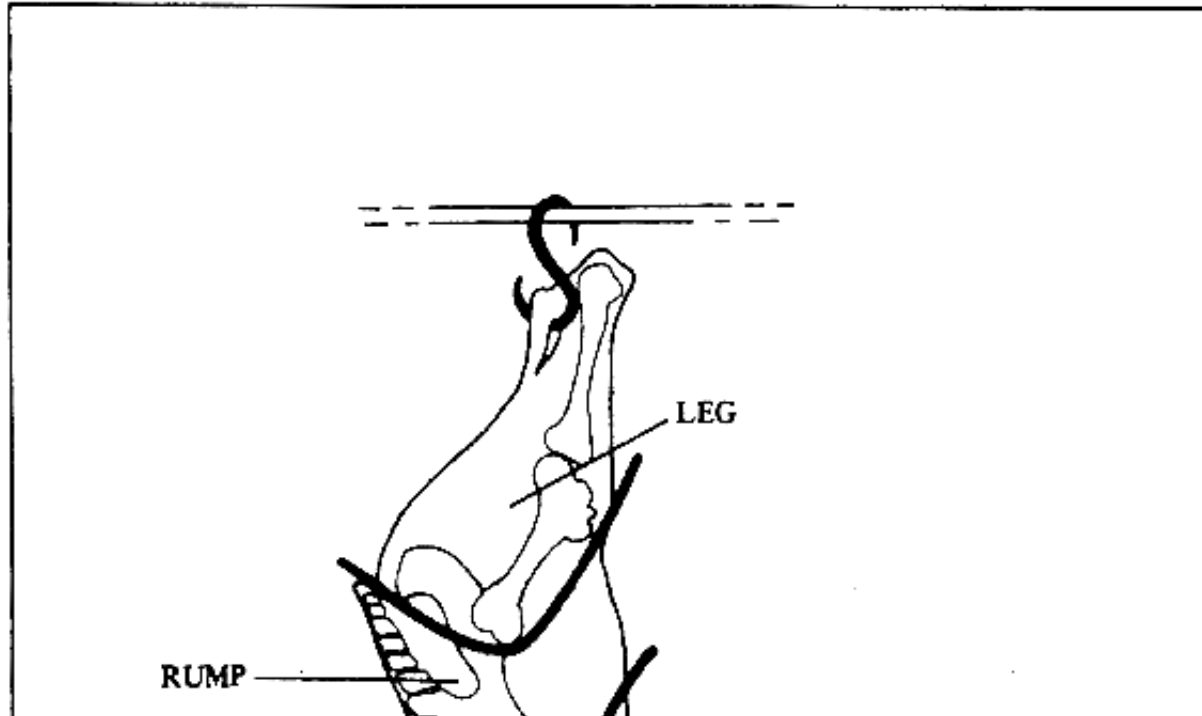
**Table 1**

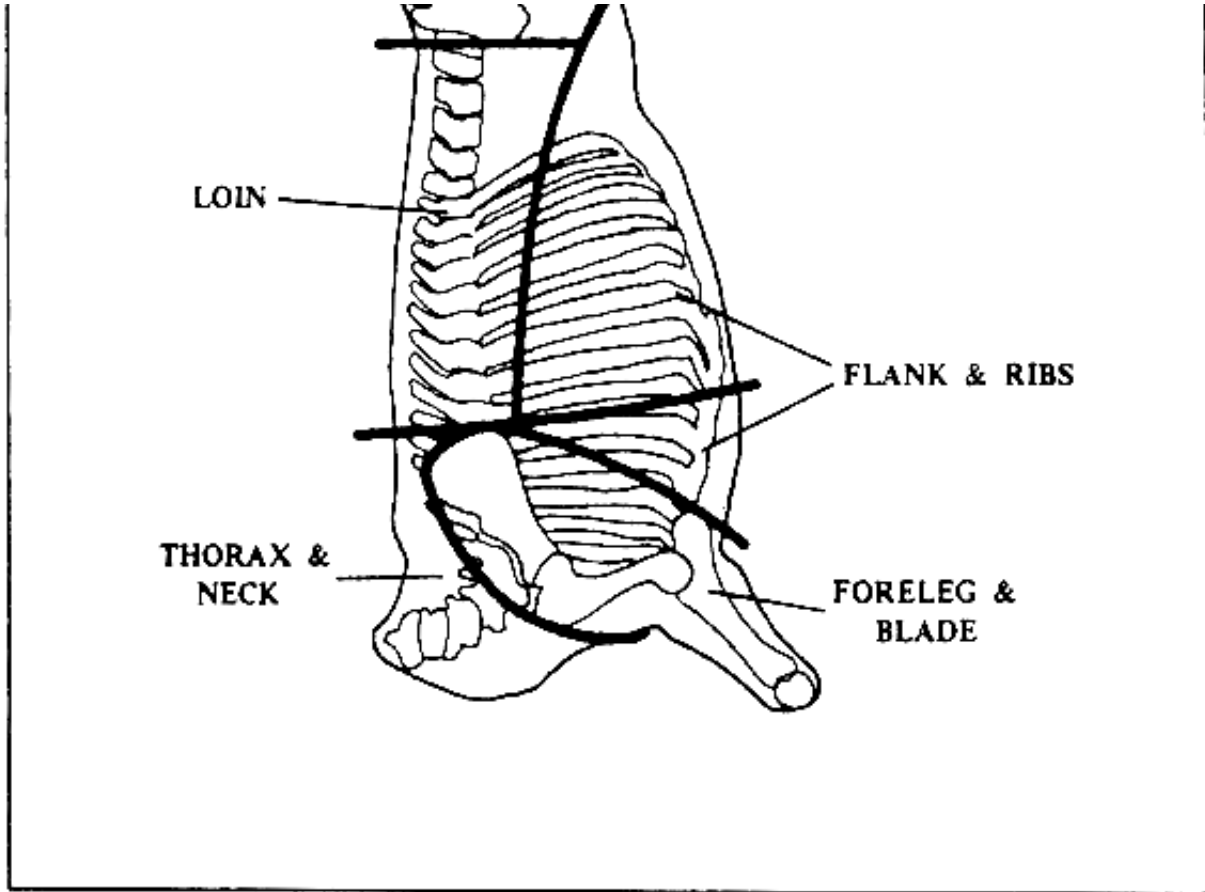
**Pistola system Primal cuts expressed in percentage of cold carcass weight**

<b>Primal cut</b>	<b>Percentage</b>
Flank and rib	14
Hind leg	29
Rump and loin	20
Foreleg and blade	15
Thorax and neck	22

**Source: ILO(1985)**

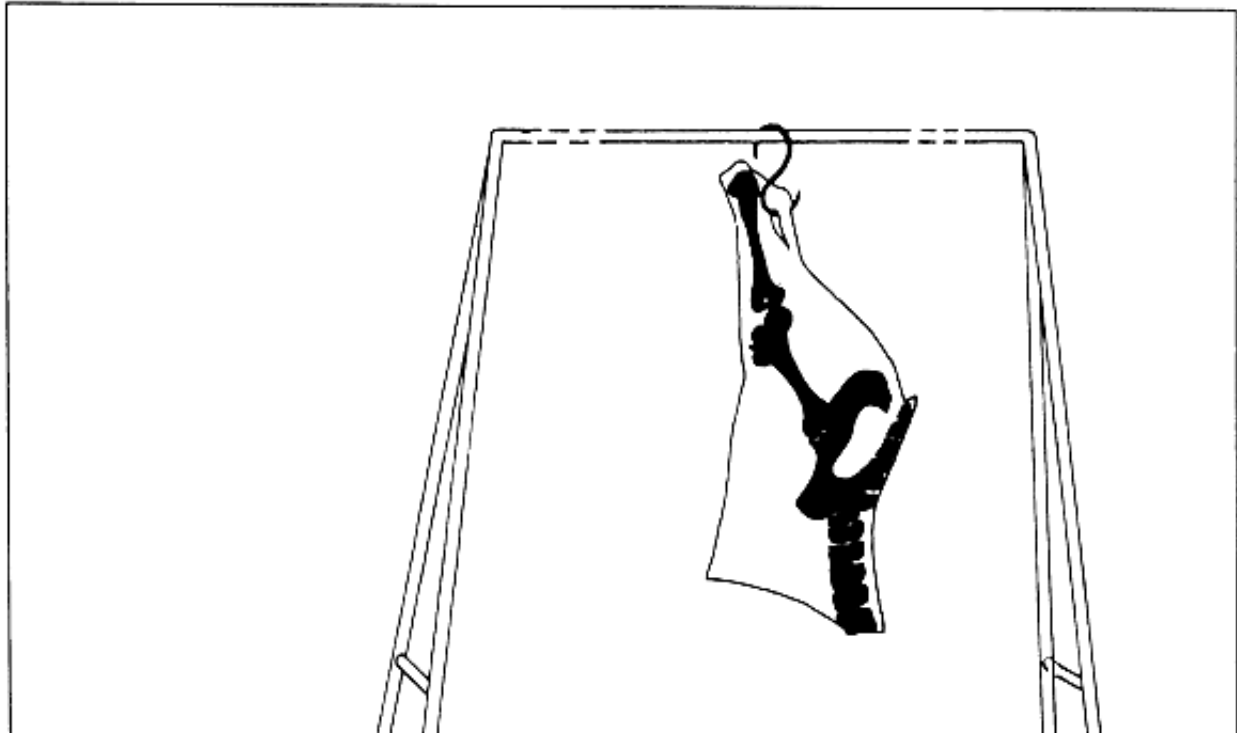
**FIG. 4.**  
**Beef carcass showing primal cuts according to pistola procedure.**





**FIG. 5.**

**Hindquarter (top) and the forequarter (bottom) separated behind the last rib. (Procedure recommended for meat for drying.)**







**After boning, the meat is trimmed to improve the quality of the finished product. Trimming consists of removing all or part of the extra fat layers, coarse tendons, fascia, nerves and blood vessels and, where necessary, bits of muscle which have been improperly cut or superficially damaged. Infiltrated fat, particularly melted fat, must also be removed to ensure a high-quality finished product which keeps well. Not only does this fat have a peculiar taste, it is sticky, unpleasant, easily becomes rancid and often forms a barrier which can interfere with the drying process.**

**The bones can be dried as well. They should be cut into smaller pieces on a clean clog. However, care should be taken to leave the connective tissue and ligaments intact, so that the pieces of the bones can be suspended for drying after having been dipped into a salt solution (see Chapter 2).**

## **SOME IMPORTANT NON-MEAT INGREDIENTS FOR MEAT PROCESSING**

***Salt*** is an important ingredient in the preparation of meat emulsions for imparting the typical flavour of processed meats and to contribute to keeping quality. The salt content of most processed meats ranges between 2.5 to 5.0 percent of the final product. A higher salt content would produce a salty taste. To function as a preservative, salt concentrations in the product of about 17 percent would be necessary, far too high for a palatable product.

***Nitrates and nitrites*** are curing ingredients. The development of the red or pink colour is their most obvious effect. In addition, nitrites:

- **affect the flavour of the products through their action as anti-oxidants; and**

- **have bacteriostatic properties, particularly in canned products (sodium nitrite is an effective inhibitor of the growth of the bacterium *Clostridium botulinum*).**

**Nitrate in itself is not effective in producing the curing reaction until it is first broken down into nitrite. This is a slow process which depends upon the presence of bacteria in brine and meat. Therefore nitrate has largely been replaced by nitrite.**

**Nitrite provides the ultimate source of the nitric oxide that reacts with the myoglobin pigment of the muscle tissue. Levels in excess of 200 parts per million of sodium nitrite should not be used. Since nitrate and nitrite are added in small amounts, it is recommended that they are first dissolved in water to ensure uniform distribution.**

***Extenders* in general are added to lower-quality products for economic reasons. Some of them improve binding properties,**

**cooking yields, slicing characteristics and flavour. The ones most often used are:**

- **dried skim milk and milk proteins;**
- **various cereal flours such as wheat, rice, oats, corn;**
- **soy products such as flours (containing about 50 percent protein), grits (which are similar to soy flour in composition but they are larger in particle size and more adaptable to meat products), textured soy protein (similar to grits except that the texture is changed to more closely resemble the texture of ground meat), soy protein concentrates (containing about 70 percent of protein, that is available either in a coarse granular form or as a flour), soy protein isolates (containing about 90 percent protein), useful both as binders and emulsifiers.**

**Various non-meat proteins are being developed for use in sausage and processed meats. These include protein from oil**

**seeds other than soya, such as cotton seed and peanuts, as well as from single-cell plant source such as torula yeast. Most extenders are usually limited to 3 percent in the dry state or to 10 percent after swelling.**

***Seasoning* is a comprehensive term for ingredients which improve the flavour of processed meats. Salt and pepper form the foundation upon which many seasoning formulae are built. Other ingredients such as spices, herbs and vegetables are supplementary, although necessary to obtain the distinctive flavour associated with various products.**

**Spices are aromatic substances of vegetable origin and include cinnamon, cassia, clove, ginger, mace, nutmeg, paprika, pepper, cardamom, coriander and mustard. They vary in composition. The aromatic and pungent components which render them valuable are present in volatile oils and resins. Some success has been achieved in extracting these components. Spice**

**extracts offer the advantage of being easier to dose and to store.**

**Condiment herbs include sage, savory, bay leaves, thyme and marjoram. The dried leaves of any of them can be used in the preparation of sausages and other meat products. Condiment vegetables are onion and garlic.**

**All spices and seasonings should be stored under dry conditions and possibly in sealed containers. They should not be exposed to direct sunlight and should only be ground or crushed on the day of manufacture.**

---



## **2. Simple techniques for production of dried meat**

### **PRINCIPLES OF MEAT DRYING**

**Drying meat under natural temperatures, humidity and circulation of the air, including direct influence of sun rays, is the oldest method of meat preservation. It consists of a gradual dehydration of pieces of meat cut to a specific uniform shape that permits the equal and simultaneous drying of whole batches of meat.**

**Warm, dry air of a low humidity of about 30 percent and relatively small temperature differences between day and night are optimal conditions for meat drying. However, meat drying can also be carried out with good results under less favourable circumstances when basic hygienic and technological rules are observed. Intensity and duration of the drying process depend on air temperature, humidity and air circulation. Drying will be**



**faster under high temperatures, low humidity and intensive air circulation.**

**Reducing the moisture content of the meat is achieved by evaporation of water from the peripheral zone of the meat to the surrounding air and the continuous migration of water from the deeper meat layers to the peripheral zone (Fig. 6).**

**There is a relatively high evaporation of water out of the meat during the first day of drying, after which it decreases continuously. After drying the meat for three or four days, weight losses of up to 60–70 percent can be observed, equivalent to the amount of water evaporated. Consequently, moisture losses can be monitored by controlling the weight of a batch during drying.**

**Continuous evaporation and weight losses during drying cause changes in the shape of the meat through shrinkage of the muscle and connective tissue. The meat pieces become smaller,**

**thinner and to some degree wrinkled. The consistency also changes from soft to firm to hard.**

**In addition to these physical changes, there are also certain specific biochemical reactions with a strong impact on the organoleptic characteristics of the product. Meat used for drying in developing countries is usually derived from unchilled carcasses, and rapid ripening processes occur during the first stage of drying as the meat temperature continues to remain relatively high. For that reason the specific flavour of dried meat is completely different from the characteristic flavour of fresh meat. Slight oxidation of the meat fats contributes to the typical flavour of dried meat.**

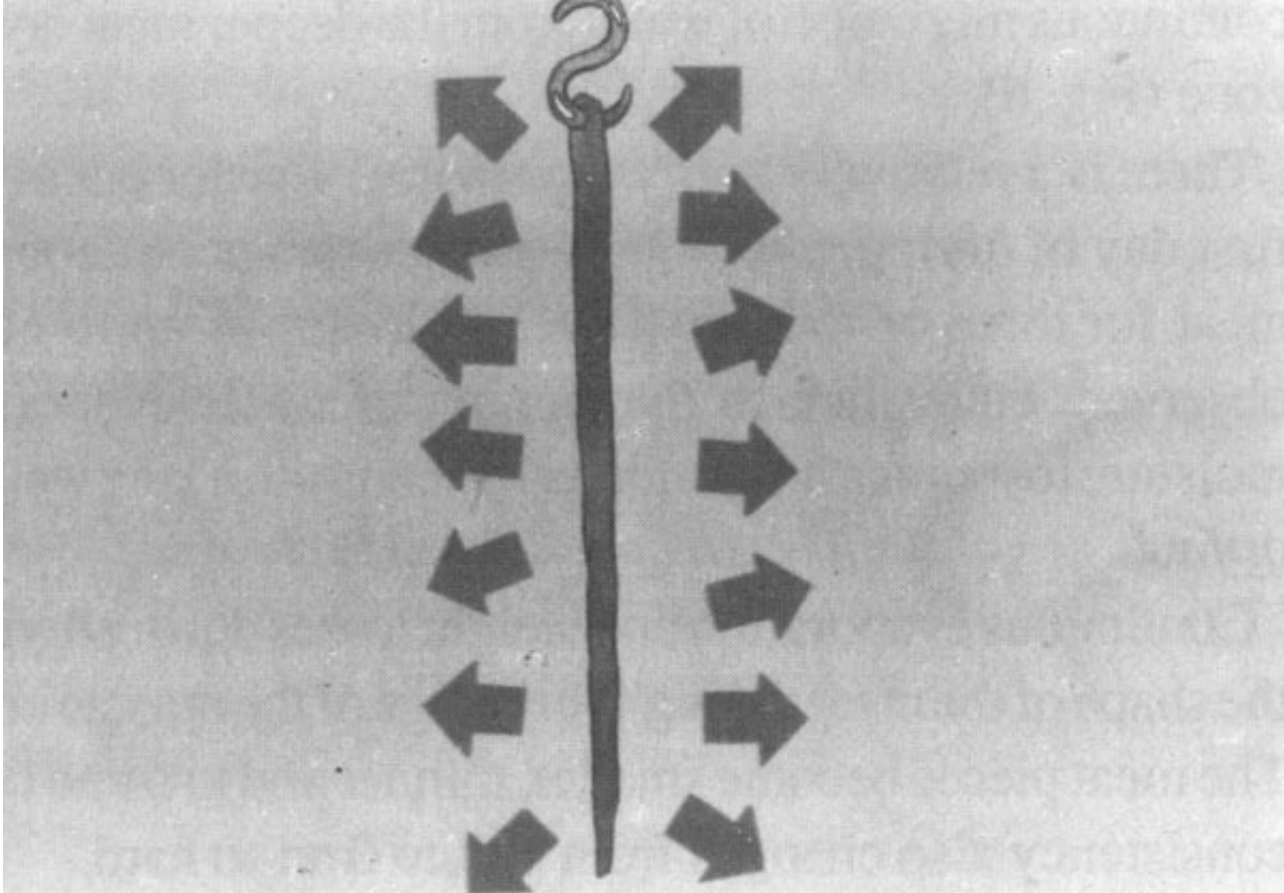
**Undesirable alterations may occur in dried meat when there is a high percentage of fatty tissue in the raw meat. The rather high temperatures during meat drying and storage cause intensive oxidation (rancidity) of the fat and an unpleasant rancid flavour**

**which strongly influences the palatability of the product.**

**Meat drying is a complex process with many important steps, starting from the slaughtering of the animal, carcass trimming, selection of the raw material, proper cutting and pre-treatment of the pieces to be dried and proper arrangement of drying facilities. In addition, the influence of unfavourable weather conditions must also be considered to avoid quality problems or production losses. The secret of correct meat drying lies in maintaining a balance between water evaporation on the meat surface and migration of water from the deeper layers.**

**FIG. 6.**

**Dehydration process of a piece of meat suspended under drying conditions (schematic).**



**In other words, care must be taken that meat surfaces do not become too dry while there is still a high moisture content inside the meat pieces. Dry surfaces inhibit the further evaporation of moisture, which may result in products not uniformly dried and in microbiological spoilage starting from the areas where the moisture content remains too high.**

**Adherence to the following meat-drying techniques should avoid failures in the production of dried meat and ensure obtaining products of good quality with a long shelf-life. The following description of the basic technology of meat drying includes the salting of the meat before drying. Presalting is not absolutely necessary, but has certain advantages, particularly for the drying of meat strips and large flat meat pieces and is therefore strongly recommended for this type of product.**

## **SELECTION OF MEAT FOR DRYING**

**As a general rule only lean meat is suitable for drying. Visible fatty tissues adhering to muscle tissue have a detrimental effect on the quality of the final product. Under processing and storage conditions for dry meat, rancidity quickly develops, resulting in flavour deterioration.**

**Dry meat is generally manufactured from bovine meat although meat from cameloids, sheep, goats and venison (e.g. antilopes, deer) is also used. The meat best suited for drying is the meat of a medium-aged animal, in good condition, but not fat. Meat from animals in less good nutritional condition can also be used for drying, but the higher amount of connective tissue is likely to increase toughness.**

**It is very important that raw material for the manufacture of dry meat is examined carefully for undersirable alterations such as discoloration, haemorrhagic spots, off-odours, manifestation of parasites, etc. Such defects must be trimmed off.**

**Carcasses have to be properly cut to obtain meat suitable for drying. Owing to their size, beef carcasses are more difficult to handle under rural conditions than carcasses of sheep, goats or game. In the absence of chilling facilities, beef carcasses must be cut and deboned immediately after slaughter.**

## **BEEF CARCASS CUTTING, TRIMMING AND DEBONING**

### **Carcass cutting**

**The carcass is first split into two sides along the spinal column and then cut into quarters. Fore- and hindquarters are separated after the last rib, thus leaving no ribs in the hindquarter. For suspension the hindquarter is hooked by the Achilles tendon and the forequarter by the last two ribs (see Fig. 5).**

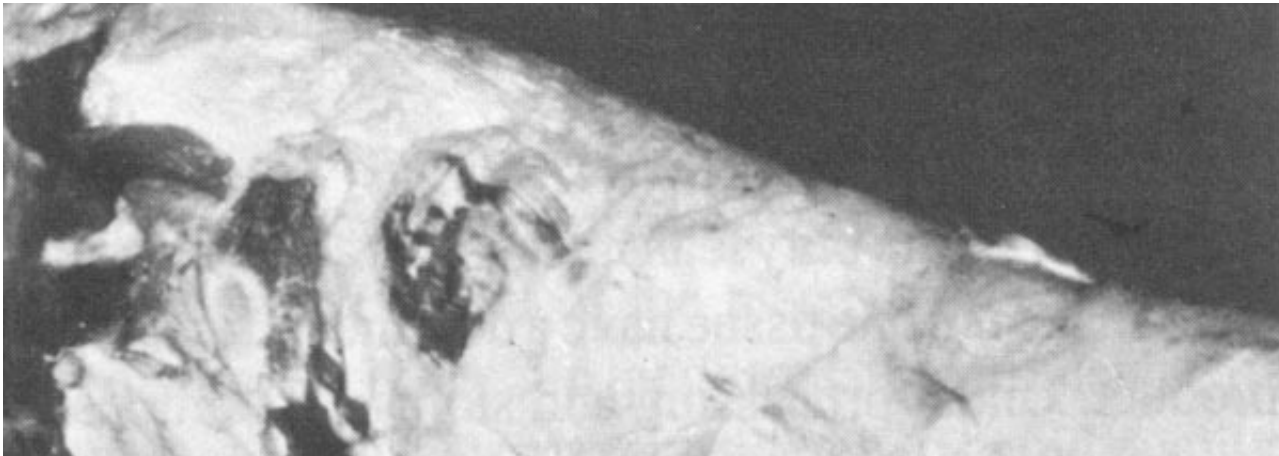
### **Trimming**

**After the quarters are suspended so that they do not touch the**

**floor or anything around them, they are trimmed. Careful trimming is very important for the quality and shelf-life of the final product. The first step is to remove with a knife all visible contamination and dirty spots. Washing these areas will spread bacterial contamination to other parts of the meat surface without cleaning the meat (Fig. 7).**

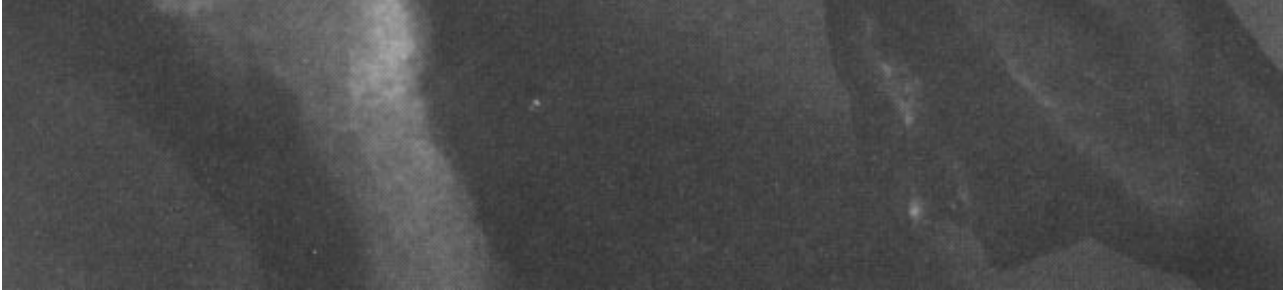
**FIG. 7.**

**Trimming a beefcarcass.**









**After completing the necessary cleaning of the meat surfaces, knives and hands of personnel must be washed thoroughly. Using a sharpened knife, the covering fat from the external and internal sides of the carcass and the visible connective tissue, such as the big tendons and superficial fasciae, are carefully trimmed off.**

## **Deboning**

**It is recommended that this operation should start with the hindquarters and follow with the forequarters. The aim is to remove the bones with the least possible damage to the muscles.**

**Incisions into the muscles are inevitable but only at spots where the bones adhere and have to be cut off.**

**Deboning of the suspended hindquarter should start from the leg and proceed to the rump and muscles along the vertebral column.**

**Deboning of the forequarter must start with cutting and deboning the shoulder separately, followed by cutting off the rib set, together with the intercostal muscles.**

**Deboning of the forequarter is completed by removing the meat from the neck and the breast region of the spinal column.**

## **TECHNIQUE OF CUTTING MEAT PIECES FOR DRYING**

**Anatomic cuts, which were separated from the carcass, are suspended again (Fig. 8) and the big individual muscles are carefully cut out, while the smaller muscles are left together. The**

**next step consists in cutting the muscles into thin strips. This operation is crucial for the appearance and quality of the final product. All strips to be dried in one batch must be cut to an identical shape. Care must also be taken to obtain rather long strips of meat.**

**There are two ways of cutting muscles or smaller muscle groups into strips:**

- **cutting the meat after placing it on an appropriate clean chopping board (Fig. 9); or**
- **cutting the muscle in the hanging position (Fig. 10).**

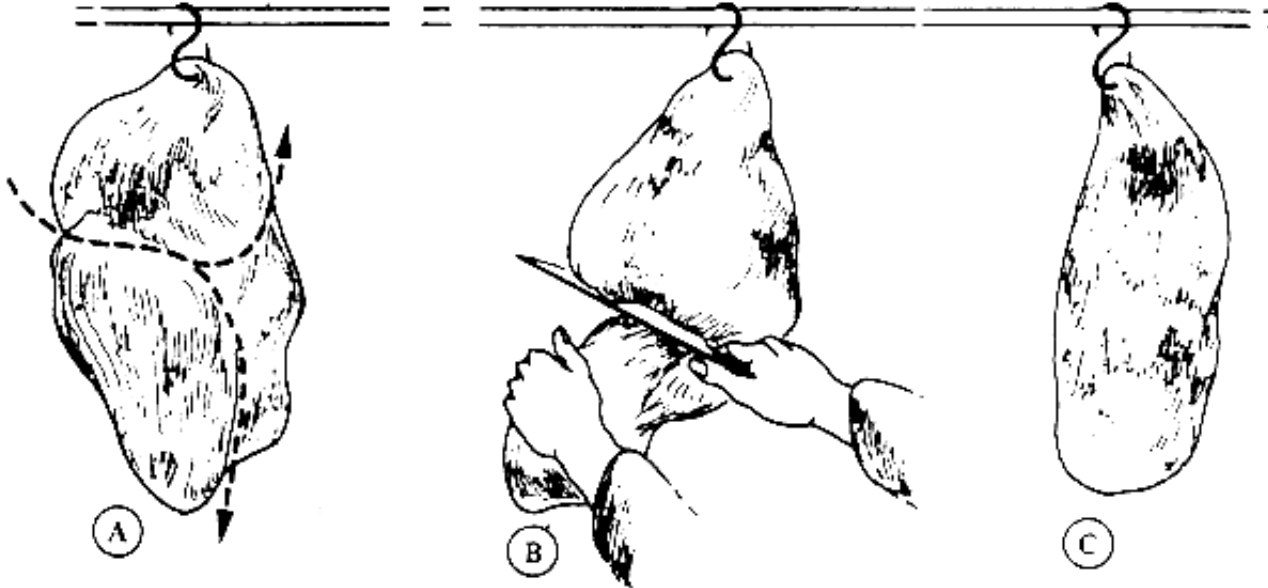
**In both cases the muscles have to be split exactly along the muscle fibres. The strips must be cut as uniformly and as smoothly as possible and the diameter of the strip must remain the same throughout the length.**

**The length of the strips may differ, though it should not be less than 20 cm and not more than 70 cm. Meat cut into shorter strips requires considerably more time for hooking than the same quantity cut into longer strips. However, strips which are too long may break because of their weight.**

**Beef muscles suitable for drying are usually no longer than 50 cm (except the sirloin strip attached to the spinal column). However, strips longer than 50 cm can be produced by cutting the muscle along the fibre in one direction, without cutting through the end of the muscle (Fig. 11). Using this technique long strips can be obtained, but their length should not exceed 70 cm for reasons of stability. The thickness of the strips determines the duration of the drying process. Since thick strips take considerably more time to dry than thin ones, it is important that strips to be placed in the same batch are of the same cross-section, with only the length differing. Insufficiently dried or overdried pieces will be the result if this rule is not followed.**

**FIG.8.**

**Suspended anatomic cut from the hindquarters (“silverside”)(A) and splitting into individual muscles (B) which result in (C).**

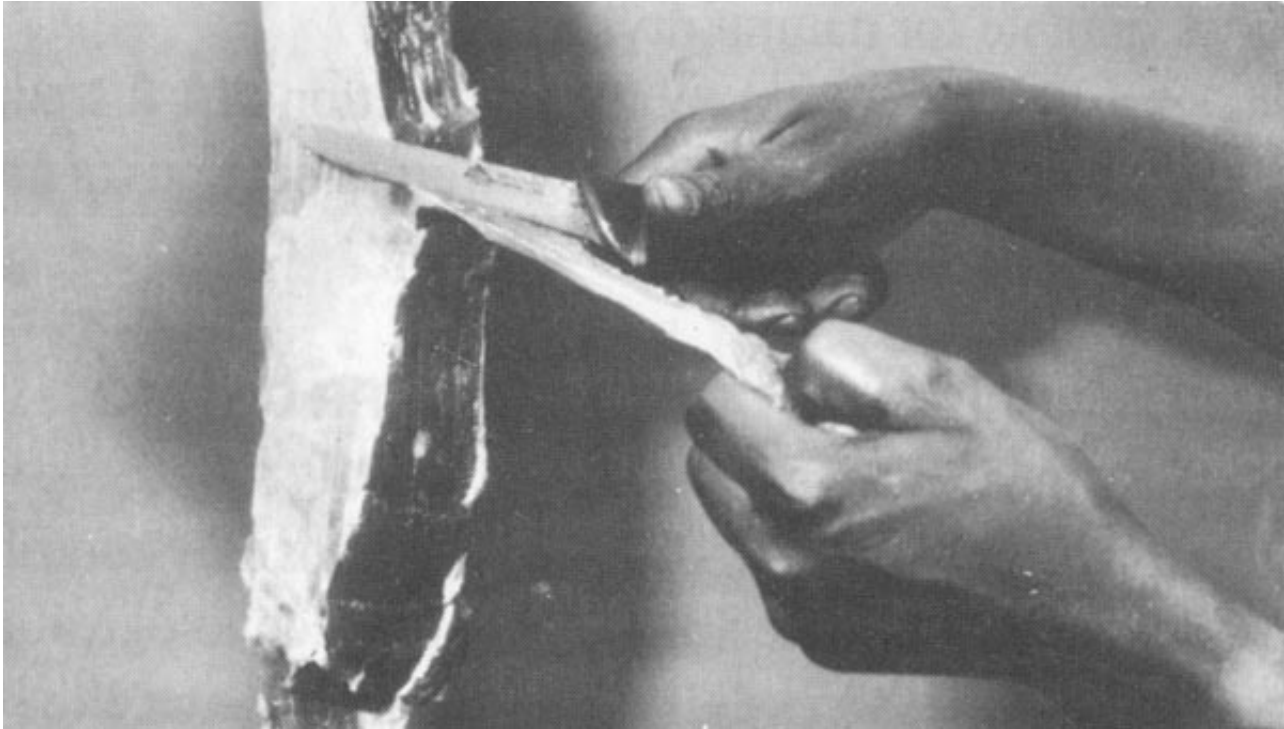
**FIG. 9**

## Cutting meat streeps from the muscle on a chopping board.



**FIG. 10**

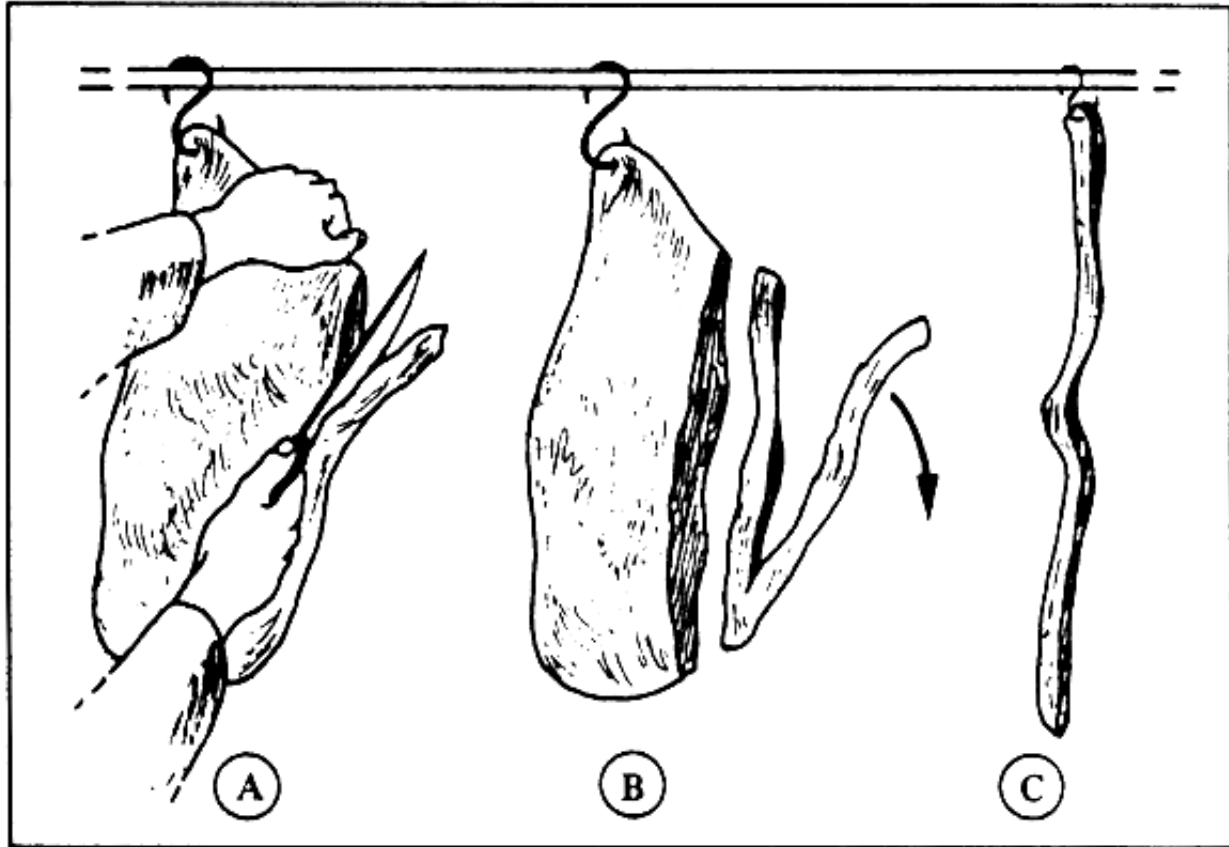
## Cutting meat streeps from a suspended muscle.



**FIG. 11**



## **Special cutting technique to obtain long meat streeps.**



**Cutting muscles into long, thin and uniformly shaped strips requires experience and skill. Knives with broad blades are best suited for this purpose.**

**Under dry climatic conditions two basic shapes of meat pieces proved to be the most suitable for natural drying:**

- **strips with a rectangular cross-section of 1 x 1 cm; and**
- **flat-or leaf-shaped pieces with cross-sections of max. 0.5 cm x approx. 3, 4 or 5 cm.**

## **RECOMMENDED TREATMENT BEFORE DRYING**

**Because meat is always consumed slightly salted, the raw material may be presalted before drying. This procedure not only contributes to a more tasty product, but is also desirable from the technological and hygienic standpoint. Pure common salt is used for this purpose, either dry or dissolved in water. In the**

**case of meat for drying cut into strips or flat pieces, the use of a 14-percent salt solution is preferred.**

**Dipping the meat into the salt solution serves first of all to inhibit microbiological growth on the meat surfaces. For that reason salting has to be carried out within five hours after slaughter, as after that period massive microbiological growth occurs which cannot be reduced by salt treatment. Secondly, presalting is a protection against insects during drying. The freshly cut meat surfaces are very attractive to various insects, in particular domestic flies, which feed on the moisture excreted from muscle fibres. These insects cause considerable contamination of the meat and may also deposit their eggs into it. Meat is no longer such an attractive environment for insects after it has been dipped into the salt solution. The salt concentration on the meat surfaces keeps them away.**

**Furthermore, a thin layer of crystalline salt is formed on the**

**surface of the meat during drying. The salt crystals are hygroscopic and absorb part of the water excreted from the meat, preserving the meat surfaces by keeping them dry. Dry meat surfaces inhibit the growth of bacteria and moulds which is one reason for the preservability of presalted and dried meat.**

**The salt solution is prepared by adding the necessary amount of edible common salt to water and dissolving it by intensive stirring. To obtain the recommended salt concentration of about 14 percent the amount of salt necessary for different volumes of water (expressed in litres) is indicated below:**

<b>Water</b>	<b>Salt</b>
(1)	(g)
5	810
6	975
7	1 140

8	1 300
9	1 460
10	1 630

**As soon as the salt is dissolved in the water, the meat strips are dipped into the solution (Fig. 12), soaked for about five minutes and then drained. Draining should be done by placing the strips into a plastic sieve in order to allow the brine to drop off for collection and re-use (Fig. 13).**

**The handling of the meat strips before drying has to be carried out under strictly clean conditions in order to avoid contamination and ensure a long shelf-life of the dried product. However, if accidental contamination of certain pieces occurs, further processing can only be undertaken with certain precautions. A special bucket with salt solution should be available in order to soak the contaminated pieces of meat, after having rinsed them previously in clean water. However, it must**

**be borne in mind that the original quality of contaminated pieces cannot be restored. For that reason such pieces should always be dried separately, and not stored for a long period, but should be used as soon as possible in the preparation of meals.**

## **METHODS OF SUSPENDING MEAT STRIPS FOR DRYING**

**The traditional way of suspending meat for drying by hanging strips over tree branches, wire or rope is not recommended because meat remains in contact with these supporting devices or may touch each other and thus not dry properly in these contact areas. Consequently, the chosen method should be to suspend the meat strips individually from one end, thus ensuring, through appropriate arrangement on the drying facility, free air circulation along the whole length of the pieces and fast and uniform drying. The contact of meat pieces with each other during drying must absolutely be avoided, since these areas will remain wet and humid for a prolonged period, thus making them**

**a favourable environment for spoilage, bacteria and flies.**

**FIG. 12.**

**Meat strips are soaked in a 14-percent salt solution for five minutes.**





**FIG. 13.**  
**Draining the brine from the meat strips after soaking using a plastic sieve.**



**The suspension of the meat strips can be done in different ways, either with hooks, loops or clips (Fig. 14).**

### **Suspension using metal hooks**

**This is a very simple but efficient way of suspending the meat strips. The meat strips are hooked at one end, always the thicker end for stability, and suspended on a horizontal wooden stick, tightrope or wire.**

**The metal hooks can easily be made, preferably from galvanized (non-corrosive) wire. Wire of 1 to 1.5 mm diameter is cut into pieces 15 cm long with a slanting cut so that the ends are sharp to allow piercing of the meat. In order to obtain an S-shaped hook, both ends of each piece are simply twisted around a circular stick (Fig. 15).**

### **Suspension using loops**

**For this purpose a thin string or a somewhat stronger thread is best suited (Fig. 16). The string is divided into pieces about 30 cm long with the ends knotted. The string is fixed to the stronger end of the meat strip by a double loop and pulled tight in order to prevent the meat from slipping out of the loop (Fig. 16D/E).**

### **Suspension using metal clips**

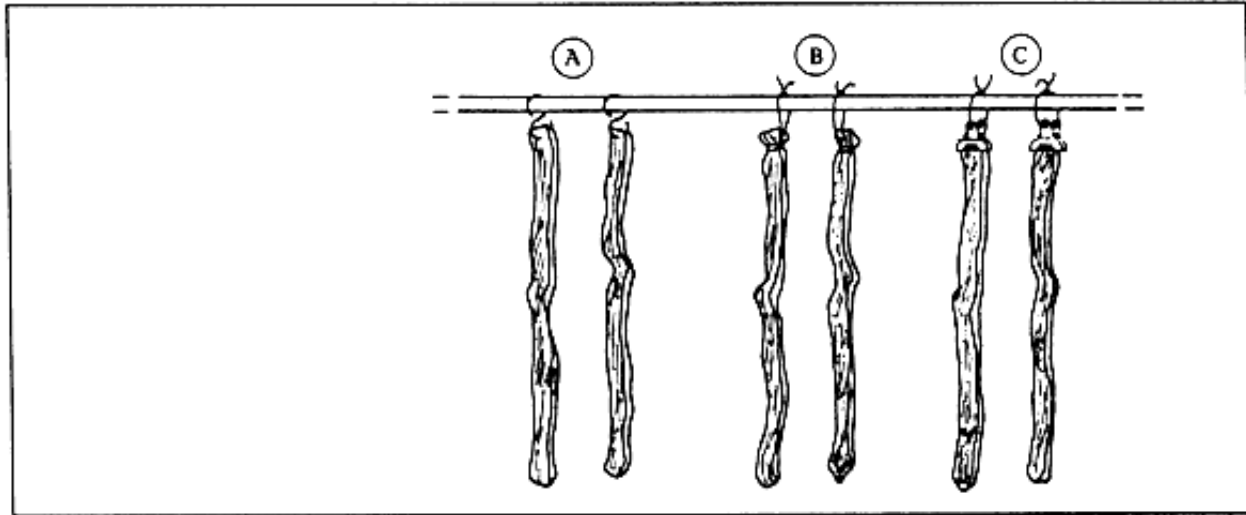
**Clips 4 to 7 cm wide are best suited. They are easily placed on the stronger end of the meat strips. Whereas metal hooks and rope loops can only be used for the suspension of rectangular or similar shaped strips, the metal clips are very practical for the suspension of flat, leaf-shaped pieces. The special advantage of hanging leaf-shaped pieces by means of a clip is that the edges of the meat do not fold in during drying.**

## **INSTALLATION FOR DRYING ENTIRE BATCHES OF MEAT**

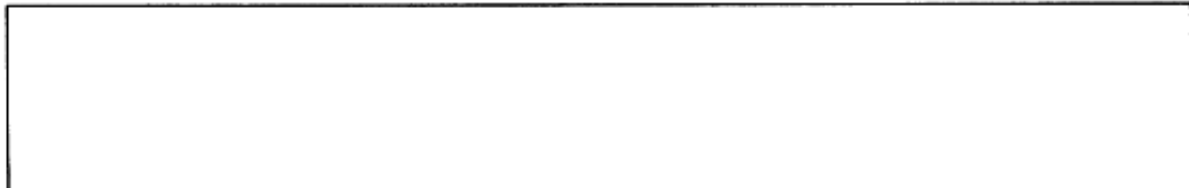
**It has already been pointed out that placing meat pieces for drying over wire, ropes or branches of trees is not recommended. Apart from problems of free air circulation under trees, some pieces may be intensively exposed to direct sun, whereas others are screened by the foliage. Furthermore, wind will transfer dust, twigs or leaves on to the meat and insects and birds will cause further damage. A general disadvantage of this very simple method of meat drying is that it is practically impossible to shelter the meat in case of storm or rain.**

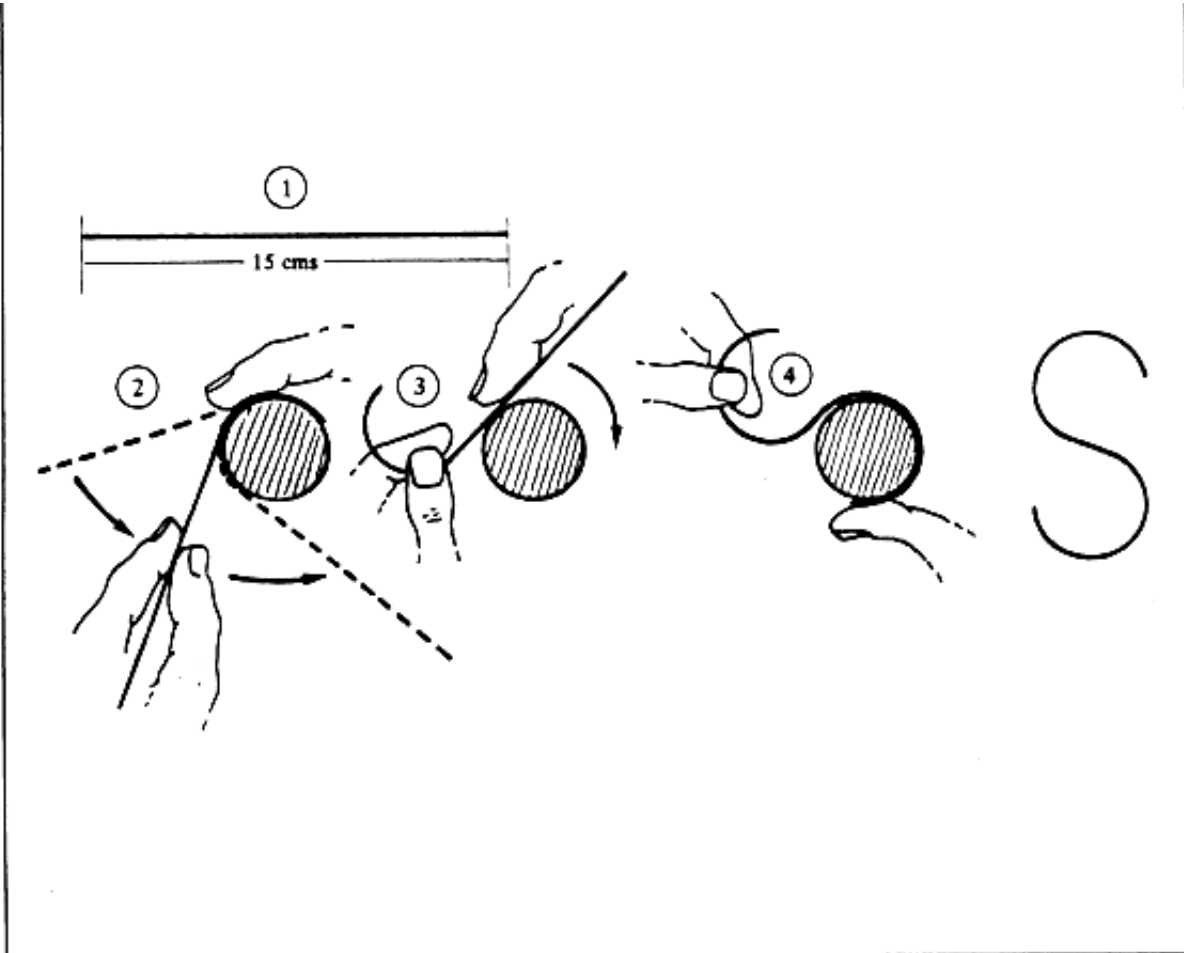
**FIG. 14.**

**Suspension of meat strips on hooks (A), loops (B), and by means of clips (C).**



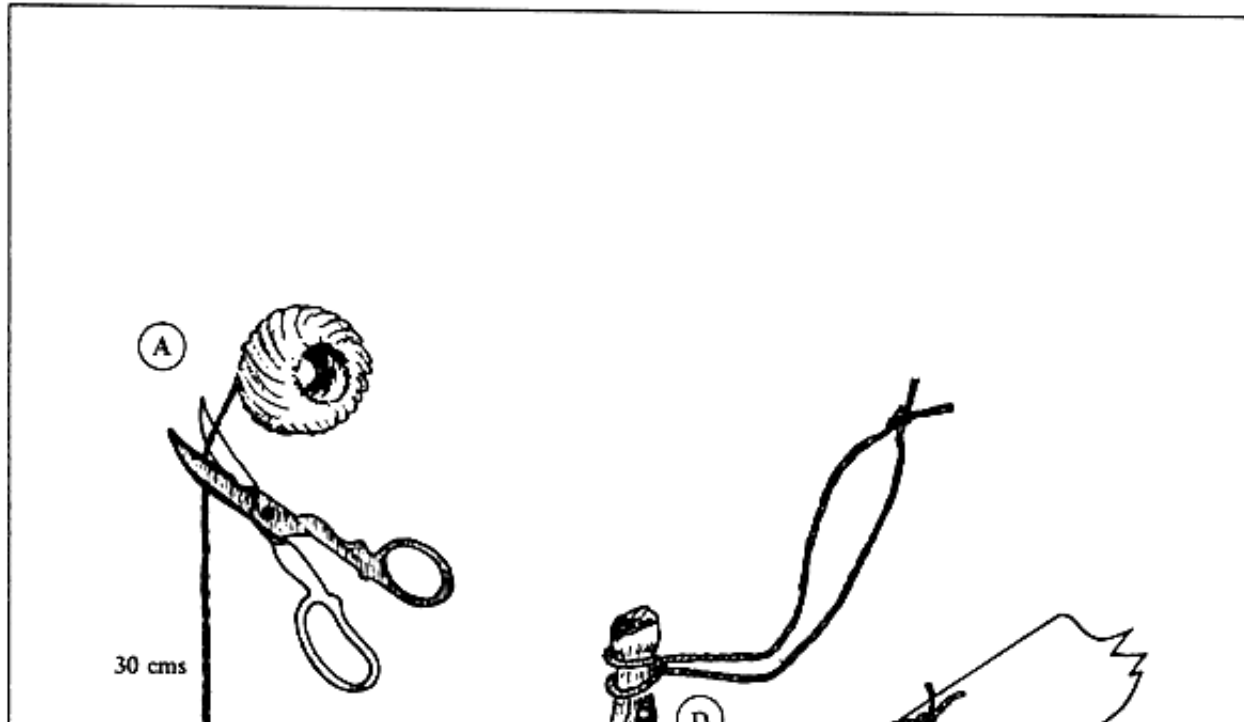
**FIG. 15.**  
**Preparing hooks from galvanized wire.**



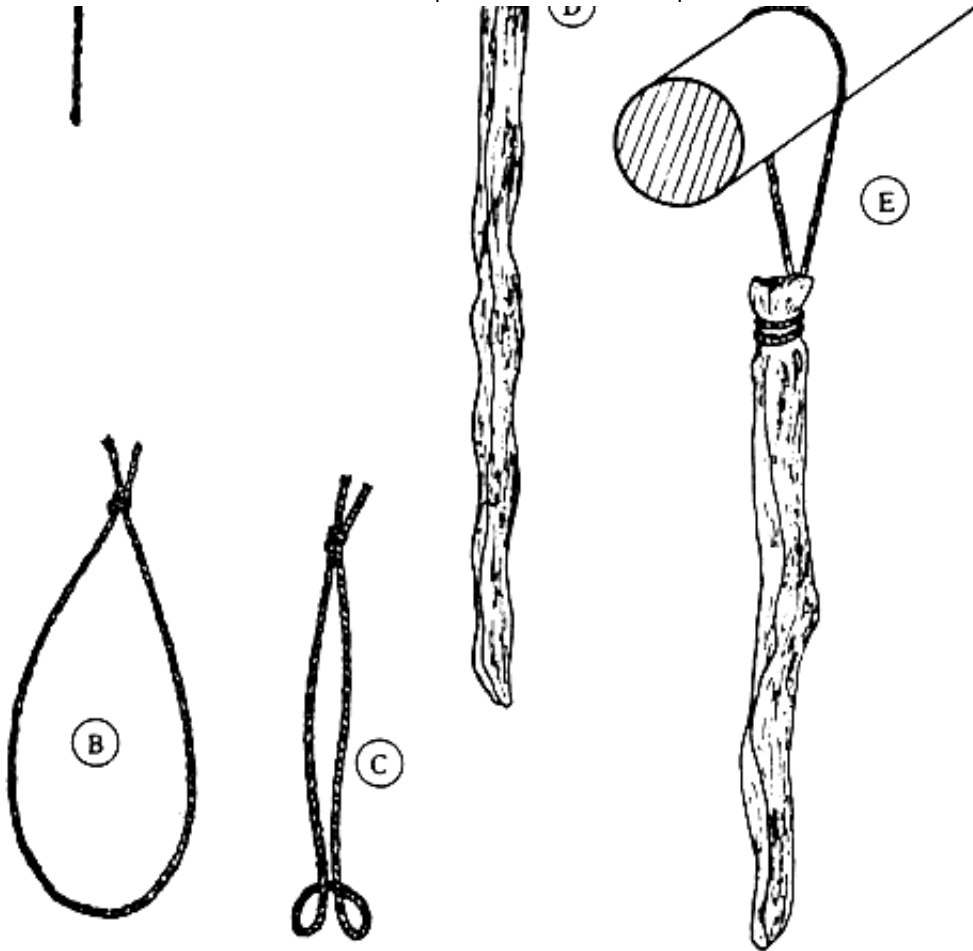


# FIG. 16

## Preparing loops from string or thread and fixing the meat strips.







**It is therefore recommended that natural meat drying be done by using simple premises and equipment, which can be made locally. The following descriptions give the different types of meat dryers.**

**These meat dryers are constructions of wood, metal and/or concrete, stationary or mobile, without or with a roof. For strips suspended by hooks or with a loop attached or fixed by clips, removable horizontal bars, either made of wood or metal or horizontal wire strings are needed.**

### **Sun meat dryer made of wood or metal**

**This dryer consists of four wooden forks planted into the ground which are connected with two longitudinal, wooden traverses of about 4 m. Wooden or metal sticks for hanging the meat streeps**

**are placed on the traverses at a distance of 15 cm from each other (Fig. 17A). If there are not sticks available, strong metal wire or plastic rope can be spanned between the two longitudinal traverses and two additional transversal traverses should be fitted for reinforcement (Fig. 17B). Similar constructions, but with iron parts and traverses instead of the wooden ones are suited for the more industrial type of meat drying (Fig. 18A/B). These constructions can also easily support a roof and meat drying can be done on two or more levels. However, care has to be taken that the traverses at the lowest level are not less than 1 m from the ground.**

### **Mobile meat dryer**

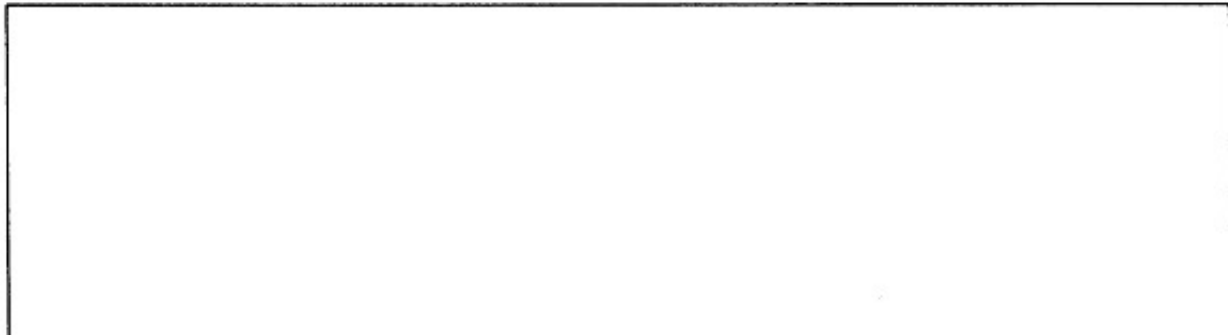
**This type of dryer, which can be easily assembled or dismantled, can be moved to places where the animals are slaughtered. Although wooden constructions can be used for this purpose, for easy assembly and for a firm base metal constructions using 40-**

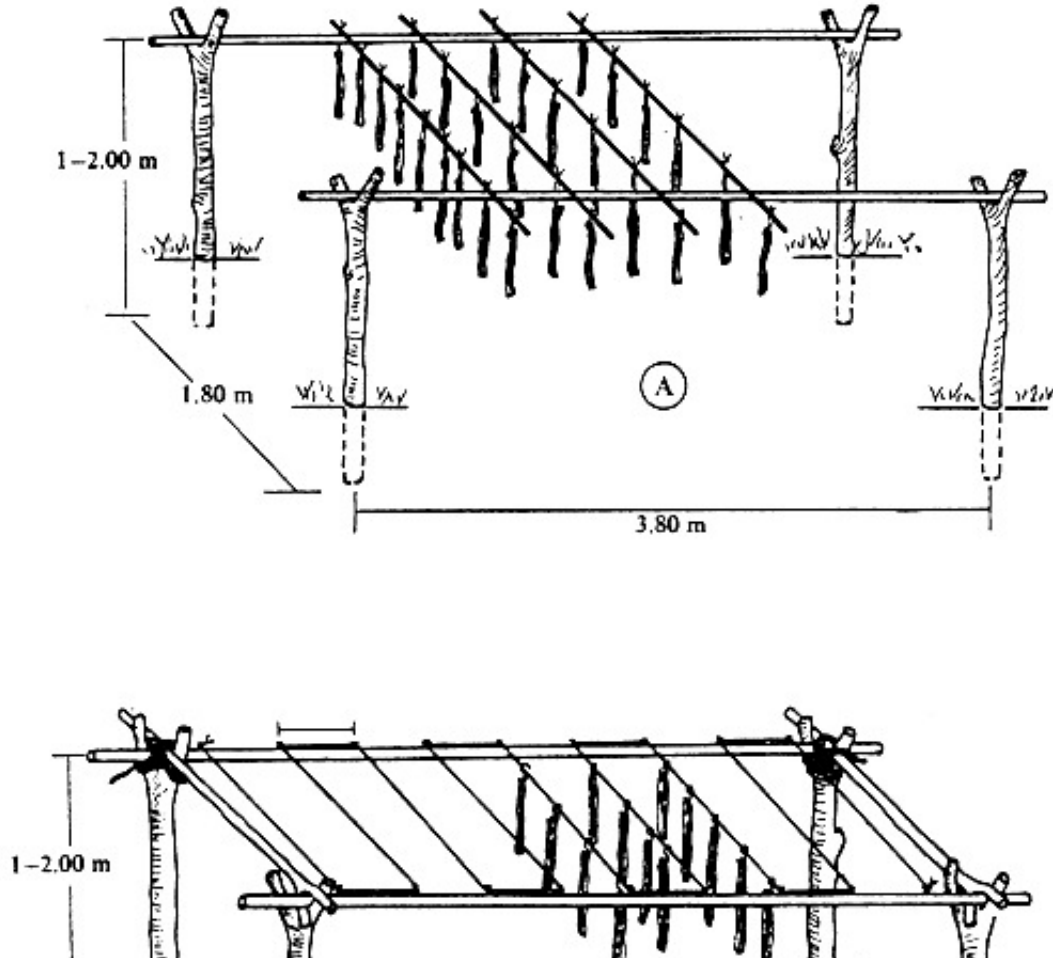
**mm tubular iron bars are more convenient (Fig. 19).**

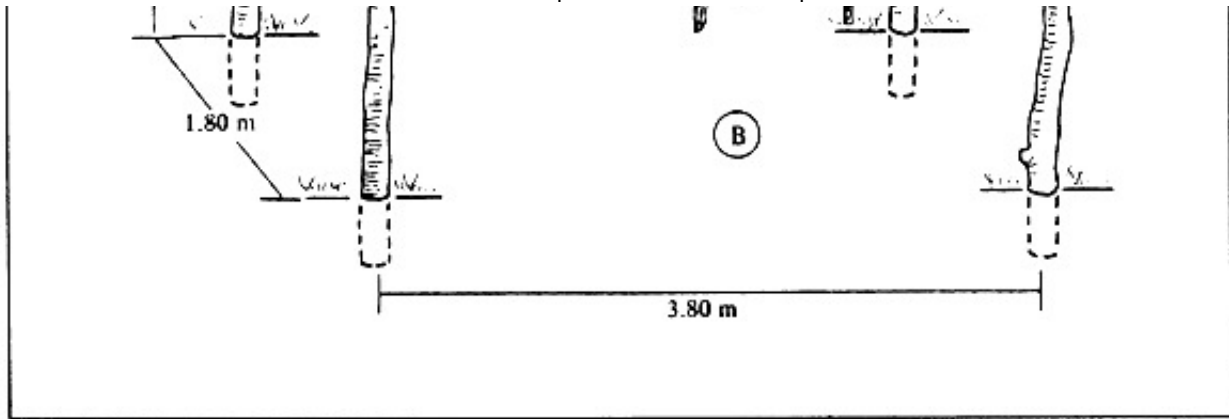
**This type of dryer consists of two rectangular frames (2 x 2 m) placed 4 m apart from each other. They are connected with four longitudinal and eight transversal metal traverses in two levels from the ground (approx. 1 m and 2 m), thus permitting meat drying on the two levels (Figs 19 and 20).**

**FIG. 17**

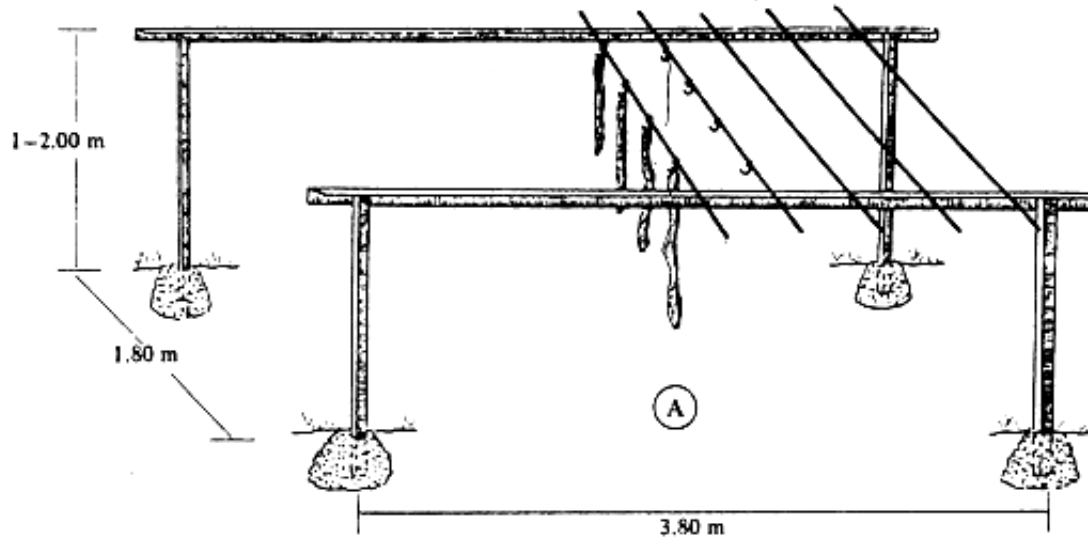
**Simple wooden construction for meat drying using sticks (A) or wire/plastic rope (B) to suspend the meat strips.**

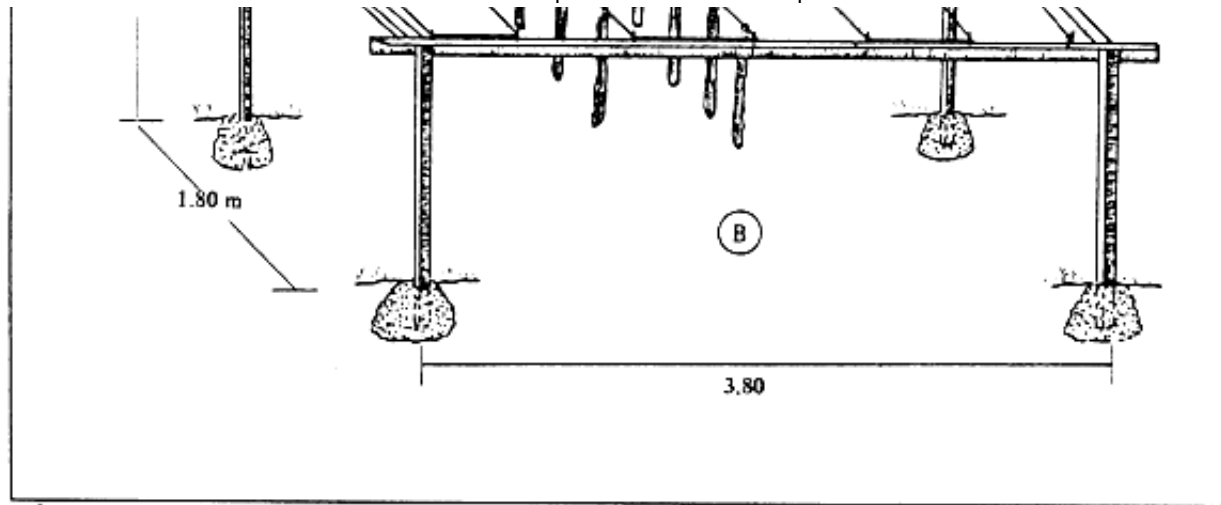




**FIG. 18**

**Simple metal construction for meat drying using sticks (A) or wire/plastic rope (B) to suspend the meat strips.**





**This dryer has the capacity for drying the meat of two beef carcasses at the same time. It is recommended that the upper level of the dryer be used for the suspension of meat from the hindquarters and the lower level for meat from the forequarters.**

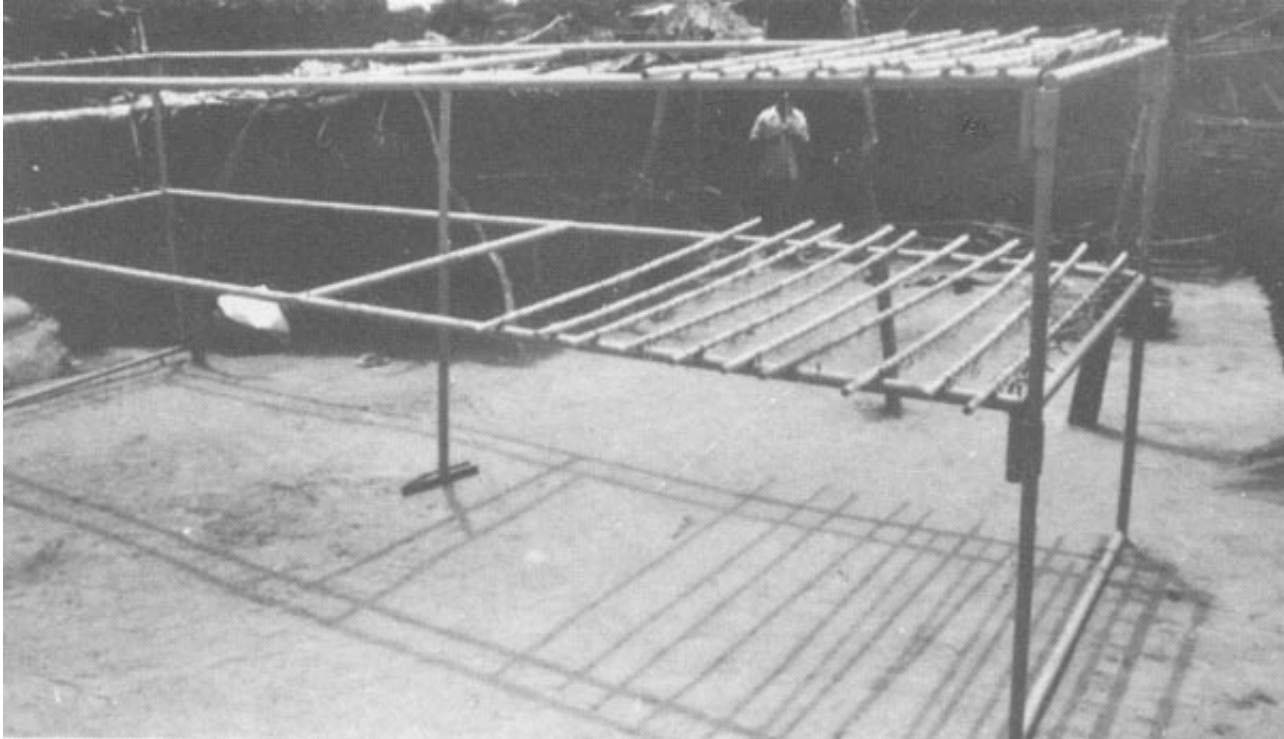
**Meat dryer with protection against external influences**



**In regions with strong and frequent winds, meat placed on the dryer must be protected from contamination by dirt, dust, sand, etc. In these cases it is recommended that the side walls of a roofed dryer (e.g. roof of corrugated aluminium, Fig. 21) be covered with plastic foil up to a height of 0.80 m to 1.20 m from the floor. It is important to ensure that the upper parts of the dryer remain open for air circulation. Protection against insects is provided by covering the sides of the dryer with insect screen (Fig. 22).**

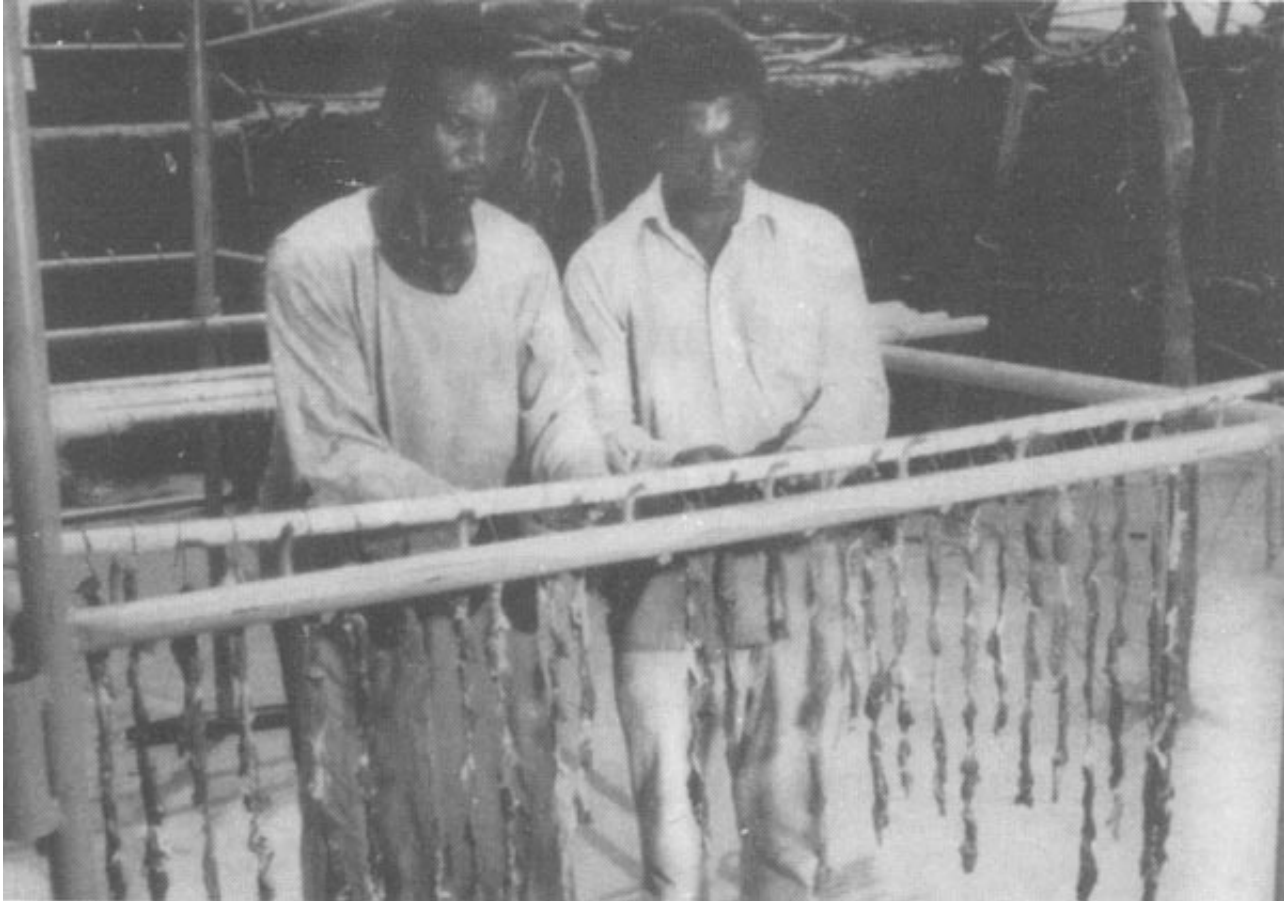
## **FIG. 19**

**Movable metal construction for meat drying.**



**FIG. 20**

**Suspending meat strips on the lower level of the dryer on wooden sticks by means of metal hooks.**



## **ARRANGEMENT OF THE MEAT STRIPS IN THE DRYER**

**In the dryer the meat strips are hung on horizontal plastic ropes, wires or sticks by means of hooks, loops or clips. As shown above, ropes and wires have often to be supported because of the heavy load of suspended meat, and they are not easily removable, which may cause difficulty in handling the meat to be dried.**

**Compared to flexible wires or ropes, firm wooden or metal sticks (Figs 15 and 16) have proved to be the better solution for the following reasons:**

- the sticks can be moved out of the dryer in order to suspend the meat pieces;**
- the suspended meat pieces maintain the correct distance from each other on the firm stick and there is no need for supports for the sticks;**

- **sticks with the suspended meat can easily be moved, for example to a smoke house or for shelter in case of a storm or heavy rain; and**
- **weight losses can easily be monitored during drying by weighing the stick plus the meat without being forced to remove the meat strips.**

**The round wooden sticks can be made locally; they are usually 2 m long and 2 cm in diameter. This size permits the suspension of 25 to 30 pieces of meat. Metal sticks are in two different shapes, one tubular, made of galvanized water-pipes, and the other T-shaped. They are more expensive than wooden sticks but they last much longer.**

**The following rules for the arrangement of the meat pieces apply to both wooden or metal sticks:**

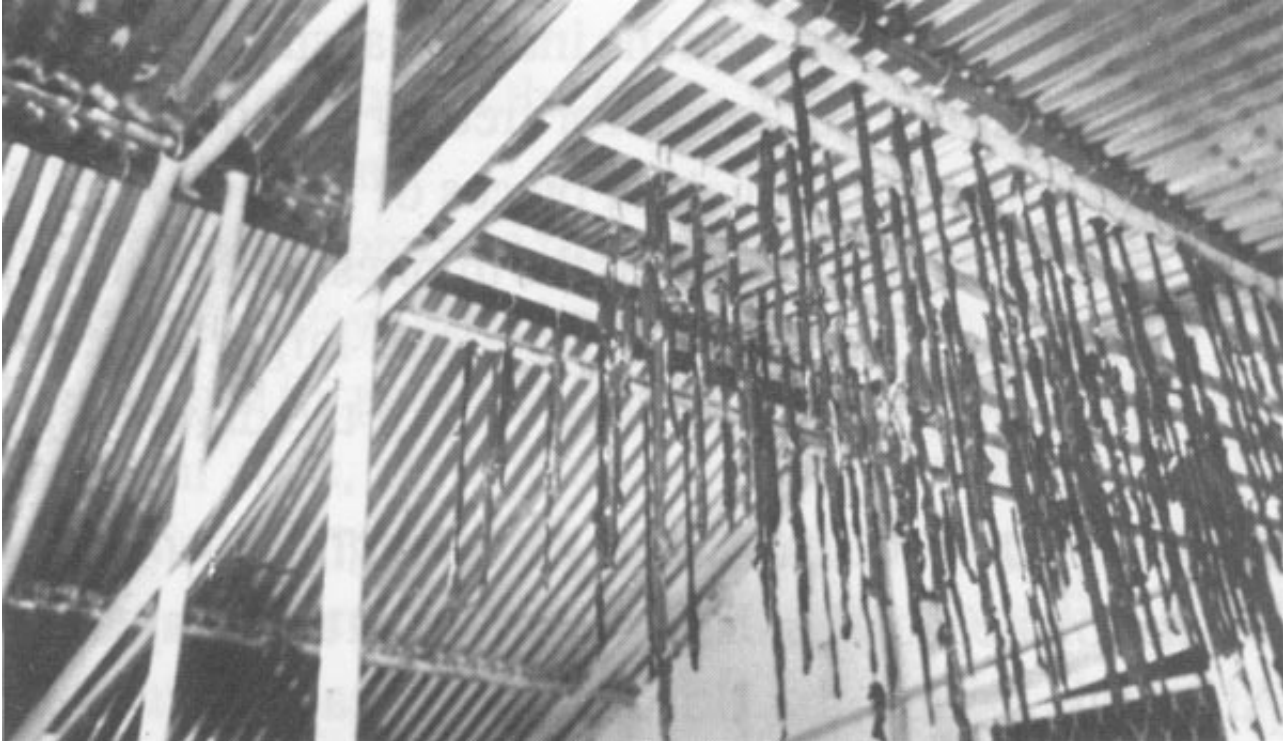
- **the number of meat pieces suspended must always remain**

**the same for all sticks in the dryer (for instance 30 per stick), for reasons of optimal air circulation and easy control of theft, etc.;**

- **the distance between the individual suspended pieces must remain the same and be sufficient for free air circulation; and**
- **the longest and thickest pieces of meat have to be placed toward the ends of the stick whereas the thinnest and shortest pieces are kept in the middle, in order to expose the larger pieces to the stronger air circulation on the external part of the dryer (Fig. 23).**

**FIG. 21**

**Roofed meat dryer (corrugated aluminium).**



**FIG. 22.**  
**Protecting the sides of a meat dryer with an insect screen.**



**FIG. 23.**

**Arranging meat strips in the dryer along sticks or wires for suspension.**





## **QUALITY OF THE FINISHED PRODUCT**

**Drying of meat of the shape described in this chapter takes four to five days. After this period the dried meat is ready for consumption and can be packaged, stored or transported (Fig. 24). At this stage the product should meet the following quality criteria.**

***The appearance* of the dried meat should be as uniform as possible (Fig. 25). The absence of large wrinkles and notches indicates the desired steady and uniform dehydration of meat.**

***The colour* of the surface, as well as of the cross-cut, should be uniform and dark red. A darker peripheral layer and bright red colour in the centre indicates incorrect, too fast drying, with the formation of hard rind which hinders evaporation from the deeper layers of the product. In this case the central parts have a brighter colour and softer consistency and are, because of the**

**higher water content, more susceptible to microbiological spoilage when packaged or otherwise stored. A softer consistency can also be recognized by pressing the meat with the fingers. These pieces should be kept for one more day in the dryer for finishing. The consistency of properly dried meat must be hard, similar to frozen meat.**

***Taste and flavour* are very important criteria for the acceptance of dried meat by the consumer. Dried meat should possess a mild salty taste which is characteristic for naturally dried meat with no added spices. Off-odours must not occur. However, a slightly rancid flavour which occurs because of chemical changes during drying and storage is commonly found in dried meat. Dried meat with a high fat content should not be stored for a long period but used as soon as possible in order to avoid intensive rancidity.**

**Dried meat must be continuously examined for spoilage-related**

**off-odour, which is the result of incorrect preparation and/or drying of the meat. Meat with signs of deterioration must be rigorously sorted out.**

## **PACKAGING AND STORAGE**

**After taking the dried meat strips out of the dryer, a selection of the pieces based on length can be undertaken.**

**Packaging serves to protect the product from contamination to which the meat might be exposed on its way from the producer to the consumer.**

**Numerous materials are used for packaging dry meat, such as paper, plastic foils (Fig. 26), aluminium foils, cellophane and textiles (Fig. 27). The longest shelf-life is obtained using vacuum-packaging. Transparent plastic material and cellophane are more appealing to the consumer. For details about packaging see**

## **Chapter 4.**

### **FIG. 24.**

### **Dried meat strips.**



**FIG. 25.**  
**Properly dried meat with a smooth surface and uniform cross-section.**



**Packaging is employed for both the retail and wholesale trade. The weight per package of dry meat for retail sale usually does not exceed 1 kg, whereas those for the wholesale trade weigh 5, 10, 25, or 50 kg.**

**If plastic bags are used for packaging, the pieces of dry meat should be cut to a certain length so that they can be best arranged in the bags. Cardboard boxes are very useful for additional packaging.**

**During storage special care has to be taken to prevent dried meat, which is not packaged in water-proof containers, from becoming wet, resulting in rapid growth of bacteria and moulds. For this reason the premises for storing dry meat have to be rain-proof. It is further advisable to cover the piles of packaged dry meat with plastic sheets, as additional protection against moisture and dust. Dry meat protected in this way can be stored for more than six months.**



**FIG. 26.**

**Dried meat strips packed in plastic bags with the opening heat sealed (above) or tied (below).**



**FIG. 27.**

**Dried meat in jute sacks for wholesale trade.**



**During storage individual packages must be opened at least once a month and the organoleptic quality of the goods examined. These controls enable the persons responsible to evaluate storage conditions and to assess the shelf-life of the dry meat.**

**For controlling temperature and air humidity, it is useful to have a thermometer and hygrometer installed on the premises (see also Chapter 5). A maximum-minimum thermometer is recommended to obtain the highest and lowest temperatures recorded between two readings. The temperature and relative air humidity should be carefully registered bearing in mind that dry meat is extremely sensitive to changes in environmental conditions, especially of the ambient temperature and relative humidity.**

## **PREPARATION OF DRIED MEAT FOR CONSUMPTION**

**Dried meat manufactured as described above has to be**

**rehydrated to resemble fresh meat again. Rehydrated dried meat has almost the same nutritive value as fresh meat.**

**Rehydration is in most cases combined with cooking. The procedure usually starts by putting the dried meat, which may be cut in smaller pieces, into a pot (Figs 28 and 29). The meat in the pot is then covered with water and boiled. The rehydrated and cooked meat and the broth are used, together with other additives which may vary according to local consumption habits, for the preparation of tasty dishes.**

**Other types of dried meat, which are manufactured by a combination of drying with special treatments, are consumed raw, without rehydration and cooking. Some examples of this group of products are given below.**

## **MEAT DRYING IN COMBINATION WITH ADDITIONAL TREATMENT**

**Meat drying after presalting, as described above, is the simplest and most efficient method of meat dehydration. Additional treatments used for some special dried meat products are curing, smoking and the utilization of spices and food additives.**

**Specific antimicrobial agents in smoke or spices or the antimicrobial properties of the curing substance, nitrite, may allow a less intensive dehydration of the meat. The resulting “semi-dry” products are in most cases consumed without rehydration, whereas rehydration is indispensable for common dried meat. In many countries, including developed countries, “semi-dry” products such as unsmoked and smoked raw hams (e.g. Parma ham, jamon serrano or smoked hams of the central European type), unsmoked or smoked dry sausages (e.g. salami, dry chorizo) or dried cured beef (Bündnerfleisch of Switzerland) are not only popular because of the products’ durability but particularly because they are delicious, high-quality meat specialities.**

**In developing countries, where the preservation aspect is even more important because of the lack of a cold chain, treatment carried out in addition to the drying of meat will be somewhat different and in some cases (e.g. intensive smoking over fire) the product quality is lowered rather than improved. The reasons for this additional treatment are in many cases adverse climatic or environmental conditions which do not allow the drying of meat without additional treatment. There are also of course other reasons for additional treatment, such as special flavours or special mixtures with non-meat ingredients, which may be preferred locally.**

### **Cured dried meat**

**Curing is the impact of nitrite on meat, in particular on the muscle pigment, myoglobin, which results in the formation of the pigment myochromogen and gives a stable red colour to muscle tissue. In addition, nitrite inhibits to some extent microbiological**

**growth in the meat, but does so efficiently only in combination with low temperatures and/or low water activity (see Chapter 4). These effects are of particular importance for the shelf-life of raw hams and dry sausages and may also be of importance for non-intensively dried biltong, the South African dried meat, which may also be manufactured with nitrite or nitrate.**

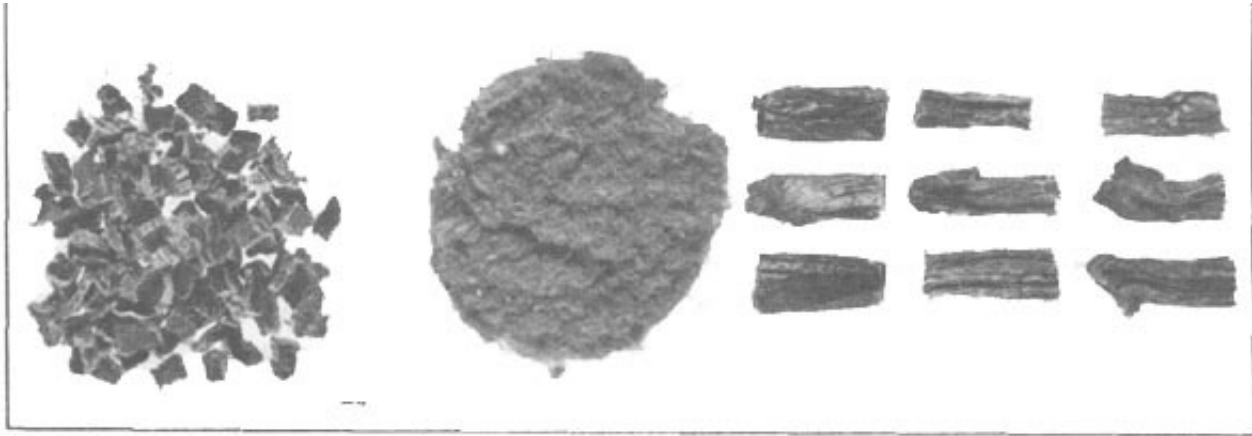
**Apart from occasional use in biltong, it can be concluded that curing is not important in the manufacture of traditional dried meat products. The reasons are that a bright red colour is not desired in dried meat (because it will be rehydrated and used for cooking meals) and drying is generally so intensive that the inhibiting effect on microbiological growth is unnecessary. Curing substances must be handled very carefully as they are toxic even in low concentrations. Very small dosages are sufficient for the curing effect, about 200 ppm, that is, 2 g or less in 10 kg meat.**



**FIG. 28.**

**Whole strips and flat pieces of dried meat and dried meat comminuted to fragments of different sizes for preparing meals.**



**FIG. 29.**

**Preparing a meal of dried meat. As a first step the dried meat is put into boiling water.**



## **Smoked dried meat**

**Smoking of meat is a technique in which meat is exposed directly**

**to wood smoke which may be generated by a variety of methods. In smoke produced from wood there are various substances which contribute to the flavour and the appearance of the smoked meat product and which have a certain preserving effect on the product.**

**However, the preserving effect of common smoking is not very significant when storing the product without a cold chain. On the other hand, intensive or prolonged smoking may considerably increase the shelf-life of the product, but it also has an unfavourable effect on flavour. Whereas a light smoke aroma generally enhances the organoleptic properties of the product, intensive smoking has a negative influence on the quality, especially in the case of prolonged storage in which concentrated smoke compounds develop increasingly unpleasant tarry flavours.**

**In view of the above, smoking in order to preserve meat can only**

**be considered as an emergency measure when no other preservation methods can be carried out. This may be the case during wet weather or generally under a humid climate, or when the preservation has to be completed as fast as possible because of the need of immediate transport, for instance after game-hunting.**

**Intensive meat smoking is always a combination of two effects, drying the meat by reducing its moisture content through hot air and the condensation of smoke particles on the meat surface together with their penetration into the inner layers of the product. Both have preservative effects and prolong the shelf-life of the product.**

**To smoke the meat, large strips and/or pieces, with and without bones, are dried by smoking in special drying/smoking places. The smoke is produced in these cases by glowing wood. Often, meat is prepared quickly by drying and smoking over a fire. In**

**this case, the meat is not only smoked, but “half-cooked” or roasted. Normally, meat from this treatment is not well prepared and has to be consumed soon after drying, otherwise it will spoil quickly.**

**The quality of traditionally smoke-dried meat is generally poor. This is not only owing to poor meat quality or inadequate smoking devices, but mainly because smoke-drying is a rather rough treatment for the meat. The process is fast and has a certain preserving effect, but at the cost of quality.**

**Quality losses are even more obvious when failures in preparing the raw material occur. When, for example, the thickness of the meat parts to be smoked ranges from about 3 cm to 15 cm, uniform drying will not be achieved. The smaller pieces will be overdried and the thicker ones may still remain with a high moisture content in the product centre. The results of faulty drying and smoking are a too strong smoke flavour, lack of**

**rehydration capacity of the smaller parts and fast spoilage of the thicker parts. For effective smoke-drying, the meat thickness should not exceed 7 cm to achieve products which are stable for a certain period without refrigeration.**

**Apart from primitive smoking places with just a fire below the meat, the construction of special smoking kilns has been suggested for smoke-drying of meat.**

**The effect of light smoking could be of interest for the production of dried meat. Light smoking is not suitable for meat preservation without a cold chain, but it adds a smoke flavour to the product and inhibits the growth of moulds and yeasts on the product's surface owing to the fungistatic smoke compounds. Thus light smoking may be used for the prevention of growth of moulds during the storage period of dried meat, especially under humid climatic conditions.**

## **Dried meat with spices and additives**

**Various methods, typical for different regions, exist to produce this type of product. General guidelines for manufacture cannot be given because of the great variety of preparations, but the idea behind all of them is to combine the necessary preservation of meat with a typical flavour. In some cases the additives act as an absorbent with the aim of faster drying, and some spices may also act against bacterial growth.**

### **TYPICAL DRIED-MEAT PRODUCTS WITH OR WITHOUT ADDITIONAL TREATMENT**

**Some examples of dried meat or dried and further processed meat manufactured in Africa, America and the Near East are described. No mention is made of the various dehydrated meat products well known in the Far East. These products are somewhat different owing to their sugar component. They will be**



**the subject of future FAO studies.**

## **Odka**

**(Somalia and other East African countries)**

**Odka is basically a sun-dried meat product made of lean beef and is of major importance to nomads in Somalia. In the face of perennial incidence of drought in the Horn of Africa, odka has become important since it is often prepared from drought-stricken livestock.**

**The production of odka is similar to the simple drying technique described earlier. However, the meat strips cut for drying are bigger and dry salting is usually applied instead of brine salting. After only four to six hours' sun-drying the large pieces of meat are cut into smaller strips and cooked in oil. After this heat treatment drying is continued and finally sauces and spices are added. For storage odka is again covered with oil and, when kept**

**in a tightly closed container, it has a shelf-life of more than 12 months.**

## **Qwanta**

**(Ethiopia and other East African countries)**

**Qwanta is manufactured from lean muscles of beef which are further sliced into long strips ranging from 20 to 40 cm and are hung over wire in the kitchen to dry for 24 to 36 hours. Prior to drying, the strips are coated with a sauce containing a mixture of salt (25 percent), hot pepper/chilli (50 percent) and aromatic seasoning substances (25 percent). After air drying the meat pieces may be further exposed to a light wood smoke and are then fried in butter fat and dried again to some extent. At this stage the product is ready for consumption or storage.**

## **Kilishi**

**(Nigeria and other arid or semi-arid zones of West Africa)**

**Kilishi is a product obtained from sliced lean muscles of beef, goat meat or lamb and is made on a large scale under the hot and dry weather conditions prevailing from February to May. It is produced by sun-drying thin slices of meat. However, recent experience indicates that kilishi can also be produced industrially using tray-drying in a warm air oven. Connective tissue and adhering fatty material are trimmed off the meat which is cut with a curved knife into thin slices of about 0.5 cm thickness, 15 cm length and as much as 6 cm width.**

**Traditionally, the slices of meat are spread on papyrus mats on elevated platforms or tables in the sun for drying. However, these papyrus mats may lead to hygienic problems, especially after repeated use. Therefore, easily washable corrosion-free wire nets or plastic nets are recommended for horizontal drying. The vertical drying method is also recommended in this case.**

**Sun-drying of kilishi could also be improved by the use of solar dryers as shown in Figs 19 and 20. These devices will increase the rate of drying of the product and keep insects and dust from the product.**

**In the first stage of drying, which takes two to six hours, the moisture of the meat slices has to be reduced to about 40 to 50 percent. The slices are then put into an infusion containing defatted wet groundnut cake paste or soybean flour as the main component (about 50 percent), and is further composed of water (30 percent), garlic (10 percent), bouillon cubes (5 percent), salt (2 percent) and spices such as pepper, ginger and onion. The “dried” slices of meat should absorb the infusion up to almost three times their weight.**

**After infusion, the wet product is again exposed to the sun to dry. Drying at this stage is much faster than at the first stage. When the moisture content of the slices has been reduced to 20**

**to 30 percent, a process which takes two to three hours depending on weather conditions and the dimensions of the product, the slices are finally roasted over a glowing fire for about five minutes. The roasting process helps to enhance desirable flavour development and to inactivate contaminating micro-organisms. Roasted kilishi is therefore superior in flavour to the unroasted version.**

**After roasting, the final moisture content ranges between 10 to 12 percent. It will decrease during storage at room temperature to as low a level as 7 percent. When packaged in hermetically sealed, low density plastic bags the product remains remarkably stable at room temperature for a period of about one year (see Chapter 4).**

## **Biltong**

**(Southern African countries)**

**Biltong is a well-known salted, dried meat prepared from beef or antelope meat. Most muscles in the carcass may be used but the largest are the most suitable. The finest biltong with the best flavour is made from the sirloin strip and the most tender is derived from the fillet.**

**The meat is cut into long strips (1 to 2 cm thick) and placed in brine, or dry-salted, which is actually the most popular method. Common salt, preferably coarse salt (1 to 2 kg for 50 kg of meat), or salt and pepper are the principal ingredients used, although other ingredients such as sugar, coriander, aniseed, garlic or other spices are included in some mixtures to improve flavour. In most cases nitrate or nitrite is added to achieve a red colour and the typical flavour of cured meat. The addition of 0.1 percent potassium sorbate to the raw meat is permitted in South Africa as a preservative. The salt/spice mixture is rubbed into the meat by hand and the salted strips are then transferred to a suitable container. It is recommended that a little vinegar be sprinkled on**

**each firmly packed layer in the container.**

**Biltong is left in the curing brine for several hours, but not longer than 12 hours (otherwise it will be too salty), and then dipped into a mixture of hot water and vinegar (approx. 10:1). The biltong is now ready for sun-drying for one day. Then the strips are moved into the shade for the rest of the drying period. The product is usually not smoked, but if it is smoked only light cold smoking is recommended, which takes one to two weeks under sufficient air circulation. The biltong is ready when the inside is soft, moist and red in colour, with a hard brown outer layer.**

**Biltong is sold in sticks or slices. The usual shelf-life is several months without refrigeration and packaging, but in airtight packages the product stores well for more than one year. Biltong is not heated during processing or before consumption. It is eaten raw and considered a delicacy.**

## **Pastirma**

**(Turkey, Egypt, Armenia)**

**Pastirma is salted and dried beef from not too young animals. In some areas camel meat is also used. The meat is taken from the hindquarters and is cut into 50 to 60 cm long strips with a diameter of not more than 5 cm. The strips are rubbed and covered with salt and nitrate. The dosage of the nitrate in relation to the meat is 0.02 percent, that means 2 g of nitrate for 10 kg of meat. Several incisions are made in the meat to facilitate salt penetration.**

**The salted meat strips are arranged in piles about 1 m high and kept for one day at room temperature. They are turned over, salted again, and stored in piles for another day. Thereafter the meat strips are washed and air-dried for two to three days in summer and for 15 to 20 days in winter. After drying the strips are piled up again to a height of 30 cm and pressed with heavy**



**weights (approx. 1 tonne) for 12 hours. After another drying period of two to three days the meat pieces are again pressed for 12 hours. Finally the meat is again air-dried for 5 to 10 days.**

**After the salting and drying process, the entire surface of the meat is covered with a layer (3 to 5 mm thick) of a paste called cemen, which consists of 35 percent freshly ground garlic, 20 percent helba (i.e. ground trefoil seed), 6 percent hot red paprika, 2 percent mustard, and 37 percent water. Helba is used as a binder of the paste; the other ingredients are spices, but garlic is the most important as it is antimycotic. The meat strips covered with cemen are stored in piles for one day, and thereafter are dried for 5 to 12 days in a room with good air ventilation, after which the pastirma is ready for sale. Thus, the production of pastirma requires several weeks. However, not much energy is required since most of the salting and drying is done at room temperature. The final product has an average water activity ( $a_w$ )**

**of 0.88 (see Chapter 5). The  $a_w$  should not fall below 0.85 or the meat will be too dry. The salt content should range between 4.5 and 6.0 percent. The product is mould-free for months at ambient temperature even in summer. Pastirma thus has a better microbiological stability than biltong.**

## **Charque**

**(Brazil and other South American countries)**

**Charque consists of flat pieces of beef preserved by salting and drying. The fresh, raw meat from the fore- and hindquarters is cut into large pieces of about 5 kg, which should not be more than 5 cm thick. The pieces are submerged in a saturated salt solution for about one hour in barrels or cement vats. On removal from the brine, the meat is laid on slats or racks above the brine tank to drain.**

**For dry-salting, the flat meat pieces are piled on a sloping,**

**grooved, concrete floor under a roof. To form a pile, salt is spread evenly over the floor about 1 cm high. Then a layer of meat is put on the salt. The meat is covered with another (1 cm) layer of salt followed by adding another layer of meat, and so on until the alternate layers of salt and meat reach a height of about 1 m. The pile is then covered with a few wooden planks and pressed with heavy stones.**

**After eight hours the pile is restacked so that the top meat goes to the bottom of the pile. The restacking process with fresh layers of salt is repeated every day for five days.**

**The salted meat is then ready for drying. Before initiating drying, the meat pieces are subjected to rapid washing to remove excess salt adhering to the surface. The meat pieces may also be passed through a pair of wooden rollers or a special press to squeeze out some surplus moisture and flatten the meat slabs. The meat is then spread out on bamboo slats or loosely woven**

**fibre mats in a shed or, in industrial production, exposed to the sun on wooden rails which are oriented north-south, thus permitting an even solar coverage.**

**Initial drying, directly in the sun, is limited to a maximum period of four to six hours. This period of exposure may be subsequently lengthened to a maximum eight hours. Temperatures in excess of 40°C on the meat surface should be avoided. To ensure even drying over the extended muscle pieces, the meat is placed on the rails during the morning and removed again in the afternoon. The meat pieces are exposed to the sun each day over a period of four to five days. After each period of exposure the pieces are collected, stacked in piles on concrete slabs and covered with an impermeable cloth to protect them against rain and wind and to hold the heat absorbed.**

**When sufficiently dry, the meat pieces are either sold without prior packaging or wrapped in jute sacks. Plastic sacks are not**

**suitable, because the product still contains a certain proportion of its original moisture content, and this moisture must be allowed to drain freely from the product. Charque keeps for months under ambient room conditions and is resistant to infestation by insects and growth of moulds.**

---



---

### **3. Meat preservation by thermal treatment**

## **CHARACTERISTICS OF HEAT-TREATED PRESERVED MEAT AND MEAT PRODUCTS**

**The prolonged shelf-life of heat-treated meat and meat products**

**is achieved through reducing growth of, or inactivating, micro-organisms by a thermal process. The principal steps of the heat preservation method are to:**

- **place the product in a container (can, glass jar, pouches of synthetic material or laminate with aluminium) which is hermetically sealed after filling and which is impermeable to any external substances; and**
- **submit the hermetically sealed product to thermal treatment with a defined temperature and time combination.**

## **EQUIPMENT FOR THERMAL TREATMENT**

**Thermal or heat treatment is done by submerging the products in cooking vats or pressure cookers which contain hot water or steam or a mixture of both. It can be performed under pressure in pressure cookers (retorts, autoclaves) in order to reach temperatures above 100°C (“sterilization”). Sterilization is the**

**most important and efficient type of heat treatment, since foods free from viable micro-organisms can be obtained and most of these products can then be stored without refrigeration. In contrast, temperatures up to 100°C can be achieved in simple cooking vats (“pasteurization”). A certain amount of micro-organisms resist this moderate heat treatment and the resulting pasteurized products must consequently be stored under controlled temperatures (see “Categories of heat-treated preserves”, p. 57.**

**In simple retort cookers (autoclaves) pressure is generated either by a direct steam injection, by heating water up to temperatures over 100° C or by combined steam and water heating. The retort must be fitted with a thermometer, a pressure gauge and a relief valve (Fig. 30). Modern autoclaves may also have revolving drums, speeding up the heating of the products.**

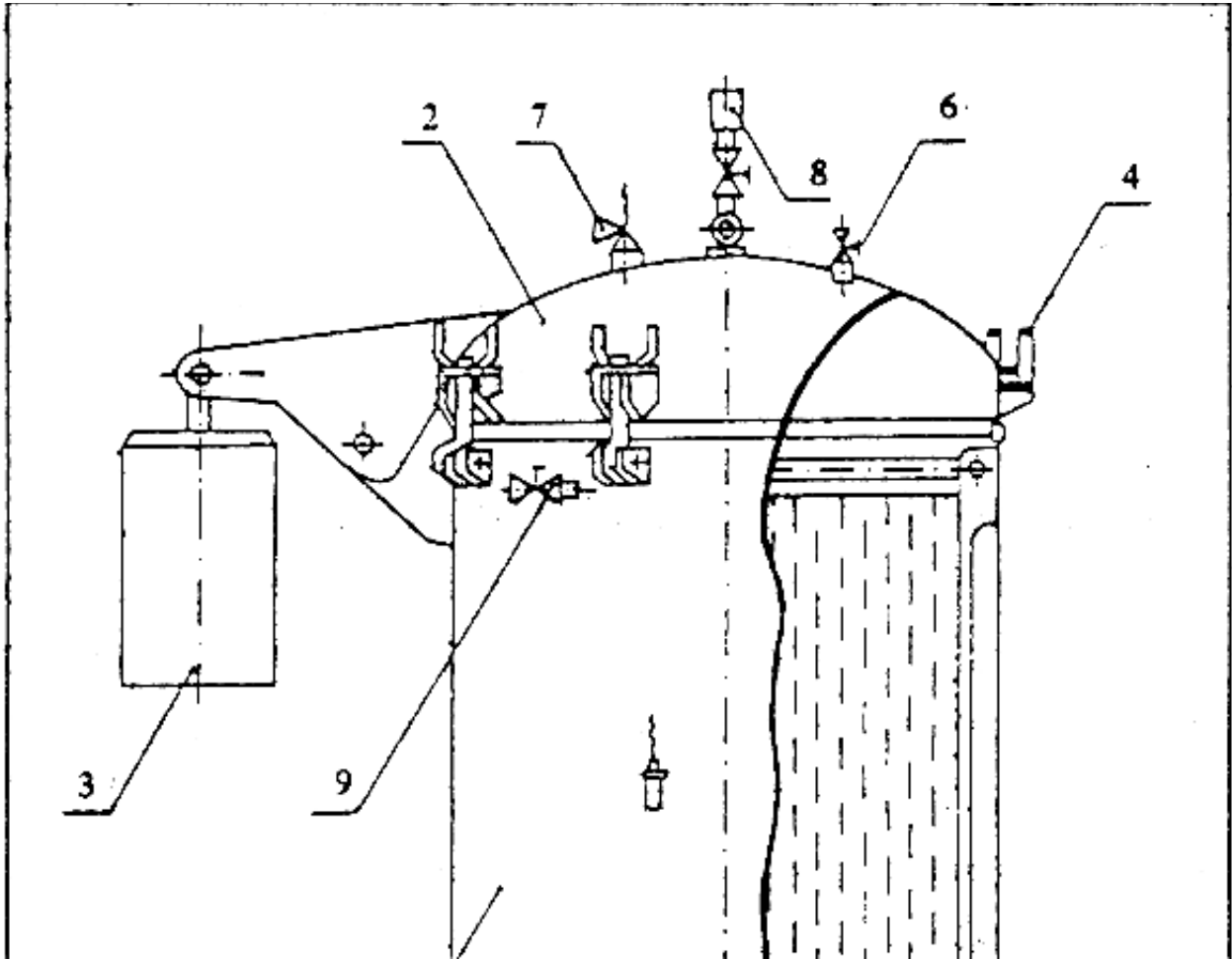
**After thermal treatment the product must be chilled as quickly as**

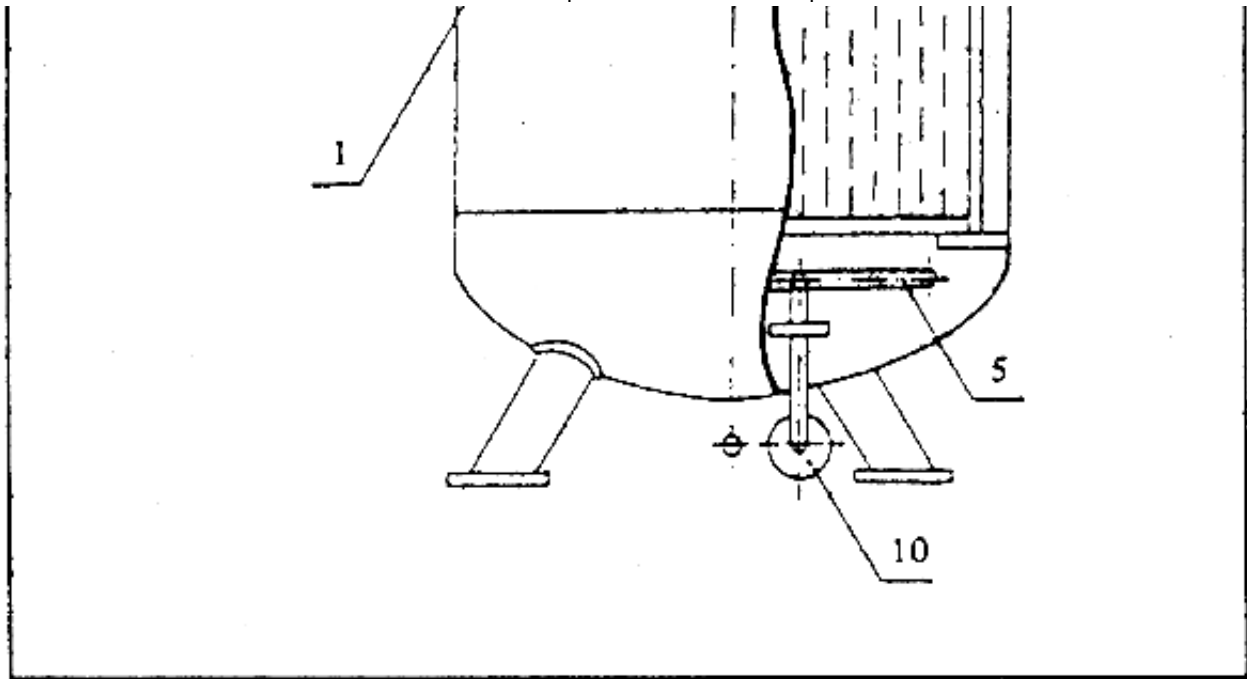
**possible, in order to avoid overcooking. Hence, this operation is done within the cooker by introducing cold water. The contact of cold water with steam causes the latter to condense with a rapid pressure drop in the retort. However, overpressure simultaneously built up during thermal treatment within the cans, jars or pouches remains for a certain period, and may induce permanent deformation or damage of these containers. Therefore, a high pressure difference between the cooker and the internal pressure in the containers must be avoided. This is generally achieved by a blast of compressed air into the retort or by sufficient hydrostatic pressure of the introduced chilling water.**

### **FIG. 30.**

**Retort cooker. 1. body, 2. lid, 3. counterbalance, 4. nuts, 5. heater, 6. vent, 7. relief valve, 8. pressure gauge, 9. water supplyvalve 10. steam supply valve.**







## CONTAINERS FOR THERMALLY TREATED PRESERVES

Containers for heat-preserved food must be airtight in order to avoid recontamination by environmental microflora. Moreover, no

**traces of undesirable substances which the packaging material may contain, such as heavy metals (lead, tin), should be permitted to migrate into the product. Currently, most of the thermally preserved products are in metal containers (cans), others are packed in glass jars or plastic or aluminium/plastic laminated pouches.**

**Metal containers are *cans* (tins) produced from *tinplate* or *tin-free* steel. They are usually cylindrical. However other shapes such as rectangular or pear-shaped cans are also encountered. Tinplate consists of steel plate, plated with tin on both sides. The steel body usually is 0.22 to 0.28 mm in thickness. The tin layer is from 0.385 to 3.08  $\mu\text{m}$ . Tin-free steel plates have other protective coatings such as chromium, aluminium, or nickel, which are generally even thinner than the tin layers of the tinplate.**

**The cans (tins) usually consist of three elements, i.e. the body and two ends. The seaming panel of the ends is fitted with a**

**synthetic lining. The ends are fastened to the body with seams made by a seaming (closing) machine. The principle of the seaming operation is illustrated in Fig. 31. Proper seaming is vital to the tightness of the can. Any leak causes recontamination, in particular during chilling. This will result in swelling of the cans during storage, and creates a risk of food poisoning.**

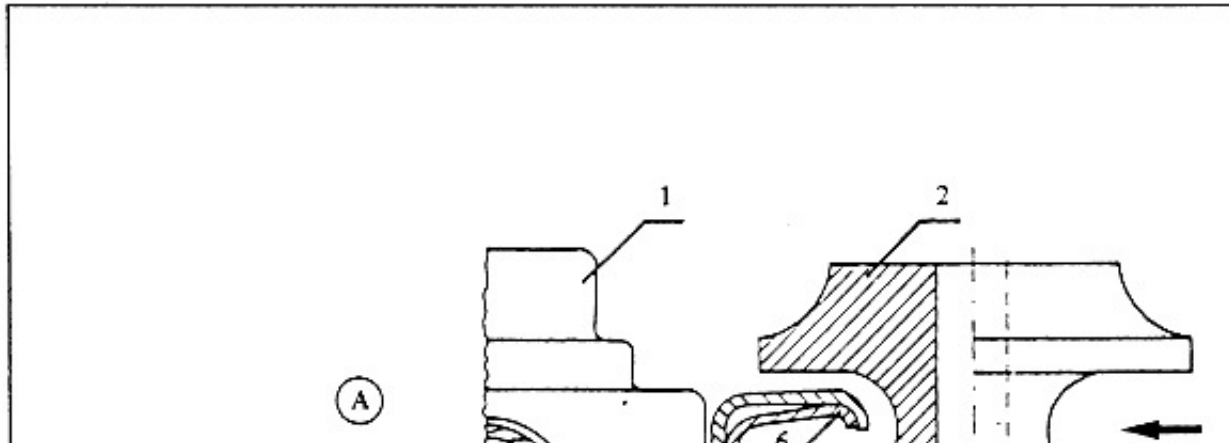
**For smaller and easy-to-open cans aluminium is frequently used. *Aluminium cans* are deep-drawn, i.e. the body and the bottom end are formed out of one piece and only the top end is seamed on after the filling operation. The advantages of aluminium cans are low weight, resistance to corrosion, good thermal conductivity and recyclability, but these cans cannot be soldered or welded. They are less rigid and more expensive than steel plate.**

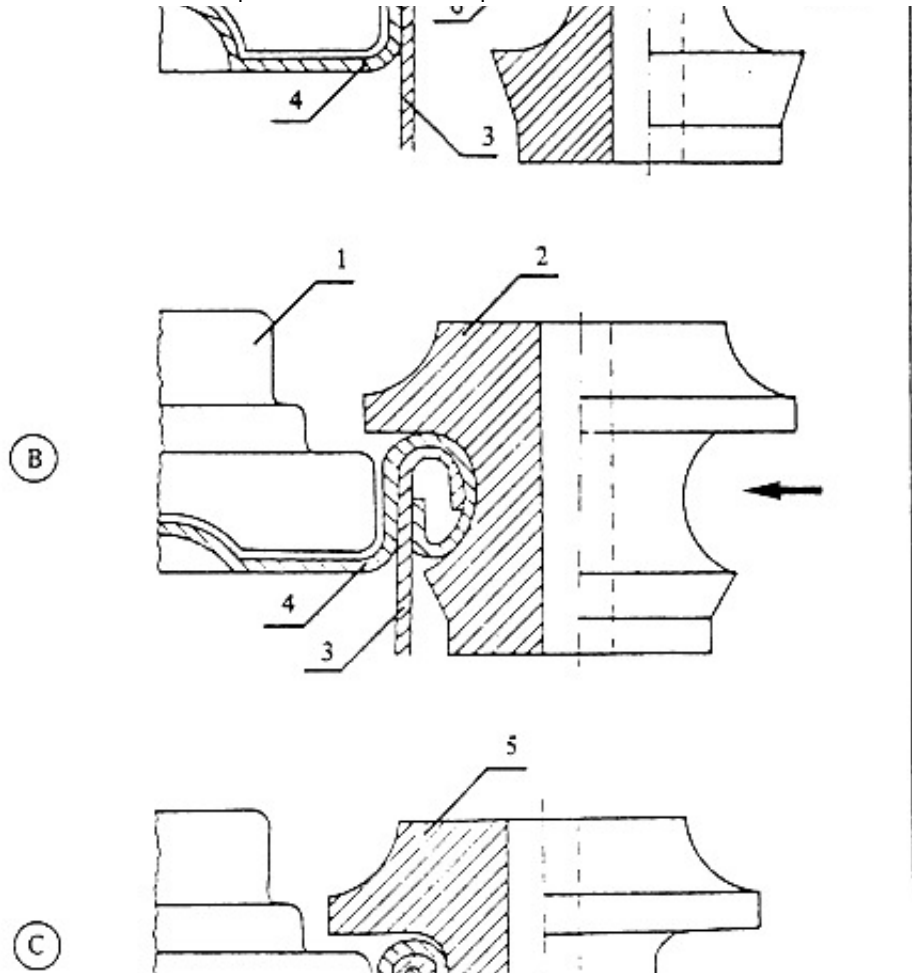
***Glass jars* are used less often for meat products because of their fragility. They consist of a glass body, and a metal lid. In**

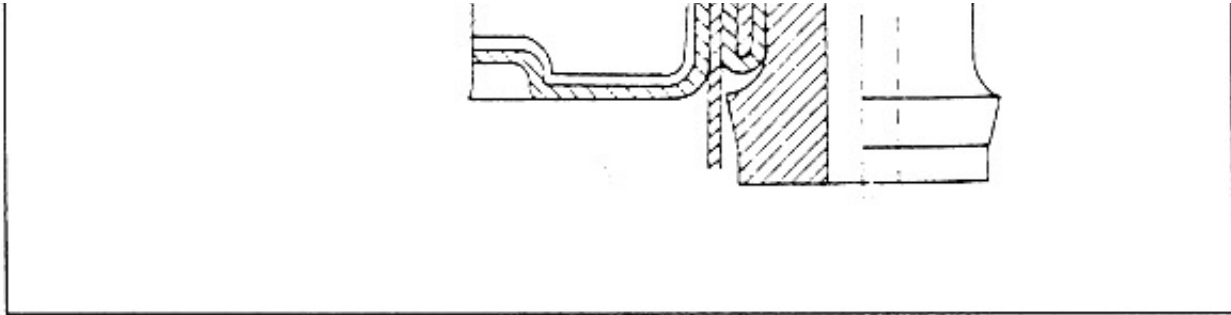
households, glass jars with glass lids are often used. The seaming panel of the metal lid has a lining of synthetic material. Glass lids are fitted by means of a rubber ring.

**FIG. 31.**

**Principles of canseaming operation. (A) initial stage of curling; (B) fully developed curling; (C) seam tightening. 1. seaming chuck, 2. seaming roll, 3. tin wall, 4. tin end, 5. seaming roll, 6. lining compound.**







**Containers made either of *synthetic material* or *laminates of aluminium foil with synthetic material* are of growing importance in thermal preservation. Heat-resistant plastic pouches, which are closed by clip, are usually made of polyester (PETP) and used for frankfurters in brine or ready-to-eat dishes. From laminated films, for instance, polyester/polyethylene (PETP/ PE) or polyamide/polyethylene (PA/PE), relatively rigid containers can be made, usually by deep drawing, which are used for filling with pieces of cured ham or other kinds of prepared meat. Widely used for small portions, particularly of sausage mix, are round containers formed out of a laminate of aluminium foil and**

**polyethylene (PE) or polypropylene (PP). PE or PP permit the heat-sealing of these containers, which can then even be subjected to intensive heat treatment.**

## **MEAT PRODUCTS SUITABLE FOR CANNING**

**Basically all meat products which require heat treatment to prepare them for consumption are also suitable for heat preservation. Only meat products which do not receive any form of heat treatment before being consumed, such as dried meat, raw hams or dry sausages, are naturally not suitable for canning. These products are conserved by a low pH value and/or low water activity.**

**The following groups of meat products, when not consumed freshly cooked, are frequently found as canned products:**

- **cooked ham**



- **sausages with brine of the frankfurter type**
- **sausage mix of the bologna or liver sausage type**
- **meat preparations such as corned beef, chopped pork, etc.**
- **ready-to-eat dishes with meat ingredients such as beef in gravy, chicken with rice, etc.**
- **soups with meat ingredients such as chicken soup, oxtail soup, etc.**

## **ORGANOLEPTIC, PHYSICAL AND MICROBIOLOGICAL ASPECTS OF THERMAL TREATMENT**

**The intensity of heat treatment has not only a decisive impact on the inactivation of micro-organisms, but also on the organoleptic quality of the product. There are products which undergo intensive temperature treatment without significant losses in quality. On the other hand, other products may deteriorate considerably in taste and consistency after sterilization. In these cases less intensive thermal treatment is required but, at the**

**same time, other hurdles, such as low pH value and/or water activity or a lower storage temperature, have to be built up in order to inhibit bacterial growth.**

**The intensity of thermal treatment can be defined in physical terms. The term widely used under practical conditions is the F-value, with which the lethal effect of heat on micro-organisms can be defined. The thermal death time for different micro-organisms calculated at 121°C and expressed in minutes, is used as the reference value.**

**The thermal death time for spores of *Clostridium botulinum* at 121°C is 2.45 minutes or in other words, an F-value of 2.45 is needed to inactivate all these spores in the product at 121°C. Spores of other micro-organisms are more or less heat resistant. Vegetative cells of micro-organisms are generally destroyed at temperatures of less than 100°C and therefore play no role in the F-value calculations (see also “Categories of heat-treated**

preserves”, p. 57). The definition of the F-value at 121°C is as follows:

**F = 1: lethal effect at 121°C on micro-organisms after 1 minute**

**F = 2(3, 4, etc.): lethal effect at 121°C on micro-organisms after 2(3, 4, etc.) minutes. In Tables 2 and 3 some examples are given for F-values obtained at different time/temperature combinations:**

**Table 2**  
**F-values corresponding to various temperatures**

95°C	per minute:	F = 0.003
100°C	per minute:	F = 0.008
105°C	per minute:	F = 0.025
110°C	per minute:	F = 0.079
115°C	per minute:	F = 0.251
121°C	per minute:	F = 1.0
125°C	per minute:	F = 2.51

130°C	per minute:	F = 7.94
-------	-------------	----------

**Table 3**  
**F-values in relation to temperature and time**

In order to reach F = 1, the following time-temperature combinations are required:	
110°C during 12.5 minutes	or
116°C during 3 minutes	or
121°C during 1 minute	or
130°C during 0.13 minutes	
In order to reach F = 4, the following parameters are required:	
110°C during 50 minutes	or
116°C during 12 minutes	or
121°C during 4 minutes	or
130°C during 0.5 minutes	

In order to reach  $F = 0.6$ , the following parameters are required:

110°C during 7.5 minutes	or
116°C during 2 minutes	or
121°C during 0.6 minutes	or
130°C during 0.08 minutes	

**The lethal effect can be shown in the reduction (in percentage) of the total number of micro-organisms present in the product. The destruction of micro-organisms is at an exponential rate, which means that the higher the initial bacterial load (using the same time-temperature combination), the higher the number of surviving bacteria.**

**Table 4**  
**Decimal reduction rates during heat treatment**

	<b>Remaining micro-organisms</b>
--	----------------------------------

<b>Initial bacterial load (micro-organisms/g)</b>	<b>Destruction rate 90%</b>	<b>Destruction rate 99%</b>	<b>Destruction rate 99.9%</b>
10 million	1 million	100 000	10 000
1 million	100 000	10 000	1 000
100 000	10 000	1 000	100
10 000	1 000	100	10
1 000	100	10	1

**The initial bacterial load and the destruction rate are shown in Table 4.**

**Table 4 demonstrates the importance of proper meat hygiene. Highly contaminated raw material with bacterial loads of 10 million per g will, even after intensive heat treatment, still give final products with a rather limited shelf-life because of the high remaining rate of contamination.**

**Since the heat treatments will in many cases not be intense enough to destroy all spores, it is important that cans be chilled as rapidly as possible after retorting and that storage temperatures generally not exceed 20 to 25°C.**

**The nature of the heat-preserved product, its pH, amount of salt and other curing agents, and the number of spores present, together with retorting time and temperature, determine the degree of commercial sterility and product safety. It has been shown that F-values of 4 in heat-preserved products will guarantee commercial sterility. Products with F-values below this level need additional measures such as lowering the pH or the  $a_w$  or refrigerated storage for their microbiological safety.**

**Micro-organisms have two adverse effects in improperly treated heat-preserved products:**

- organoleptic deterioration through protein degradation;**

- **food poisoning by bacteria and/or toxins.**

**The food-poisoning aspects require special care during production and storage of heat-treated preserves, bearing in mind that some heat-resistant micro-organisms are able to produce dangerous toxins, amongst them *Clostridium botulinum*, which may have fatal consequences.**

## **PRACTICAL APPLICATION OF F-VALUES**

**By measuring the temperature of the product periodically during thermal treatment, the final F-value can be determined. It is obvious that during thermal treatment the product temperature will rise constantly. The temperature taken in the centre of the container after each minute of heat treatment corresponds to a certain F-value (see Table 3). These partial F-values are added up (for example by using special tables containing F-values corresponding to temperatures from 90°C to 140°C) and the sum**



**is the overall F-value of the product.**

**The exact F-value is of special importance for the producer because:**

- **it ensures appropriate thermal treatment of the product, thus avoiding over-or undercooking;**
- **it enables the product's storage time to be determined.**

**In practice it is not necessary to calculate the F-value repeatedly for the same type of batch processed in the cannery. The F-value can be determined once for each batch according to the size of the containers and intensity and duration of thermal treatment. If these parameters remain unchanged, the F-values will not be subject to alteration.**

## **CATEGORIES OF HEAT-TREATED PRESERVES**

### **Pasteurized products**

**Only slight thermal treatment. Temperatures reached in the product centre are in the range of 82°C and below 100°C (“pasteurization”). The F-value cannot be determined, remaining almost at zero.**

**Inactivated: most vegetative micro-organisms**

**Not inactivated: spores of *Bacillus* and *Clostridium***

**Storage required: uninterrupted cold chain (2–4°C), up to six months**

## **Cooked preserves**

**Thermal treatment only with boiling water (no pressure cooker).**

**Temperature reached in the product centre is up to 100°C. Low F-value.**

**Inactivated: all vegetative micro-organisms**

**Not inactivated: spores of *Bacillus* and *Clostridium***

**Storage required: not higher than 10°C for one year. Spores will not grow under these conditions.**

### **“Three-quarter” preserves**

**Thermal treatment in pressure cooker. Temperatures reached in the product centre are between 108 and 112°C. F-value 0.6 to 0.8.**

**Inactivated: all vegetative micro-organisms, spores of *Bacillus***

**Not inactivated: spores of *Clostridium***

**Storage required: not higher than 15°C for one year. Spores of *Clostridium* will not grow under these conditions.**

### **“Full” preserves stable under temperate conditions**

**Intensive thermal treatment in pressure cooker. Temperature reached in the product centre is about 121°C. F-value 4 to 6 (“sterilized product”).**

**Inactivated: all micro-organisms except thermophilic spores**

**Storage required: ambient temperature (for one year), but not tropical conditions (40°C or more).**

**“Full” preserves stable under tropical conditions**

**Very intensive thermal treatment, with a long period of 121°C or higher in the product centre. F-value of 12 and more.**

**Inactivated: all micro-organisms including thermophilic spores**

**Storage required: ambient temperature even under tropical conditions (up to four years).**

**Shelf-stable preserves**

**This group of preserves is different from those mentioned previously, since preservation is achieved not only by thermal treatment, but also by utilizing other means to prevent microbiological growth such as nitrite, low water activity and/or**

**low pH. This combined effect has the advantage of a fully shelf-stable product under all ambient conditions without undergoing intensive thermal treatment (less than 100°C) and without major losses in organoleptic quality.**

**Shelf-stable preserves are a fairly new development in the food sector and will certainly gain special importance in countries without an uninterrupted cold chain.**

**Thermal treatment of different intensity for different products is used to avoid deterioration, which varies from product to product. The following table gives some examples on how thermal treatment should be conducted. It is a general rule in this context that products in smaller containers can undergo more intensive thermal treatment because of faster heat penetration.**

## **Table 5**

### **Recommended thermal treatment for selected products**

## (temperatures to be reached in the product centre)

<b>Pasteurized preserves (68–80°C)</b>	<b>F &lt; 0.6– 0.8 110– 115°C</b>	<b>F &gt; 4 121–140°C</b>
<p>Cooked ham or pork shoulders in large cans (up to 16 lb or 7.3 kg) or in large deep-drawn plastic bags (2–3 kg).</p> <p>Sausages in impermeable synthetic casings.</p> <p>Ready-to-eat dishes in plastic pouches.</p>	<p>Bologna-type sausage mix in cans or jars.</p> <p>Liver or blood sausage mix in cans or jars.</p>	<p>Frankfurters in brine (glasses, cans or plastic bags).</p> <p>Sausage mix, luncheon meat, cooked ham in small cans or small deep-drawn laminated aluminium containers.</p>

(These products are not considered commercially sterile. They receive only treatment sufficient to destroy vegetative cells. Therefore, refrigeration is required to prevent germination of spores.)	Meat mince such as lunch- meat in cans.	Corned beef (all sizes of containers).  Ready-to-eat dishes with gravy (all sizes of contain-heat ers).
--	---	---



## 4. Impact of packaging methods on meat preservation

In most developing countries meat carcasses are handled and stored either without or with only minimal refrigeration. A fast-

**turnover system is used, ensuring that meat slaughtered during the night and morning is sold and consumed the same day. This well-proven traditional method functions satisfactorily because in the short period between slaughtering and consumption, micro-organisms cannot increase to the extent of spoiling the meat and making it inedible. This system is eminently suitable for rural villages and small towns in many developing countries, particularly because local cooking habits do not call for ripened and tender meat.**

**This fast turnover of meat normally does not lead to meat spoilage, although massive contamination during slaughtering and meat handling frequently occurs. Fortunately, in most cases toxic micro-organisms do not develop to such an extent to threaten consumers' health, provided that the time between slaughter and meat cooking is short and cooking is done properly and with sufficiently high temperatures.**



**In traditional meat handling, fresh meat is generally not packaged at all or just wrapped in paper, leaves, etc. Meat, traditionally preserved by drying, is sometimes packaged in linen bags, baskets or pottery to facilitate storage and transport and to provide some kind of protection against dirt, insects, etc.**

**With higher concentrations of population, however, this traditional system now becomes outmoded in some places in developing countries because more time is needed between slaughtering and ultimate consumption. Meat frequently has to be stored, transported, prepared and distributed through a retailer or supermarket, all of which is considerably time-consuming. In order to safeguard fresh meat during this extended time, certain methods of preservation have to be applied. Refrigeration is the obvious solution, but this is expensive and therefore frequently not available in developing countries. Energy-saving storage methods are therefore particularly relevant in underdeveloped areas. For both methods,**

**either using the refrigeration technology or energy-saving methods to extend the shelf-life of meat and meat products, proper packaging has an important part to play.**

## **PURPOSE OF PACKAGING FRESH AND PROCESSED MEAT**

**The purpose of packaging is primarily to protect foodstuffs during the distribution process, including storage and transport, from contamination by dirt, micro-organisms, moulds, yeasts, parasites, toxic substances or those influences affecting smell and taste or causing loss of moisture. Packaging should help to prevent spoilage, weight losses and enhance customer acceptability.**

**Simple packaging without further treatments is less effective in prolonging the shelf-life of meat and meat products. Frequently full advantage of packaging can only be achieved in combination with preservation methods.**

## **FACTORS AFFECTING THE SHELF-LIFE OF MEAT AND MEAT PRODUCTS**

**Though meat handling, storage and consumption may differ from one place to another, the factors limiting the shelf-life of these products are the same.**

**There are *endogenous* factors, such as:**

- **pH-value or the degree of acidity of the product (see Ch. 5);**
- **$a_w$  value or the amount of moisture available in the product (see Ch. 5); and *exogenous* factors, such as:**
  - **oxygen (from the air);**
  - **micro-organisms;**
  - **temperature;**
  - **light; and**
  - **evaporation and desiccation.**

## **COMBINED EFFECT OF PH- AND $A_W$ -VALUE**

**Generally speaking the shelf-life of meat and meat products will be longer the lower the pH-value and/or  $a_W$ -value. Both factors (either pH or  $a_W$  alone or the two together) have a decisive influence on the growth of micro-organisms in food. However, there are limits for most meat products regarding decreased pH-value and  $a_W$ -value, particularly for organoleptic reasons. Except for some special products, consumers do not want meat products to be excessively acidic or dry.**

**Uncanned meat products can be classified into three storage groups according to their pH and  $a_W$ . Each group requires different storage conditions.**

***Highly perishable* meat products have a pH-value above 5.2 and an  $a_W$ -value above 0.95; refrigeration at or below +5°C is needed.**

**These are raw fresh meat (without additives), bologna-type sausages, cooked sausages and cooked ham.**

***Perishable* meat products have a pH-value below 5.2 or an  $a_W$ -value below 0.95. Refrigeration at or below +10°C is needed to keep them stable. Products such as meat or poultry pieces in vinegar jelly (acid) and semi-dry sausages or hams belong to this group.**

***Shelf-stable* products have a pH-value of or below 5.2 and an  $a_W$ -value of or below 0.95, or only a pH-value below 5.0, or only an  $a_W$ -value below 0.91. No refrigeration is required in these cases, the products remaining stable under ambient temperatures. The most common products in this group are the various kinds of dried meat.**

**Under the above conditions no microbial growth in meat and meat products will occur. However, this does not mean that the**

**products remain stable for an undetermined period. Their shelf-life will be limited by chemical or physical deterioration, by rancidity and discoloration. In this situation the product quality will benefit from the application of suitable packaging materials, which reduce the physical and chemical influences on the product or protect the product completely. The following noxious influences may occur.**

## **Oxygen**

**The oxygen content in the air is about 20 percent. If oxygen affects meat and meat products during prolonged storage periods, it will change the red colour into grey or green and cause oxidation and rancidity of fats with undesirable off-flavours.**

**The foils used for food packaging differ in their permeability to oxygen. The lower the oxygen permeability of the packaging**

**material, the more efficient will be the protection of product quality. The best protection will be achieved using oxygen-proof packaging films together with vacuum packaging of the product. This ensures that practically no oxygen is left in the package and no oxygen will penetrate from the air into the product.**

## **Light**

**The prolonged exposure of meat and meat products to daylight or artificial light accelerates oxidation and rancidity because light provides the energy for these processes.**

**Transparent packaging films give no protection against light influences. Therefore, for products under strong light exposure, coloured or opaque films should be preferred. Films laminated with aluminium foil are absolutely impermeable to light. Products in transparent packaging film are sufficiently protected when kept in the dark or under moderate illumination.**

## **Evaporation**

**Fresh foods with a relatively high moisture content such as meat, fresh sausages, cooked ham, etc. will have considerable losses of weight and quality by evaporation during storage if they are not packed. The packaging material must therefore be sufficiently vapour-proof. Most plastic films used for food packaging comply with this requirement.**

## **SECONDARY CONTAMINATION**

**During slaughtering, carcass dressing, meat cutting and/or processing, the contamination of meat to some extent cannot be avoided. The further growth of micro-organisms in meat and meat products cannot be stopped through packaging only. However, secondary contamination of these foods, for example by contact with dust, dirty surfaces and hands, can definitely be prevented through proper packaging, preferably with plastic films**



**which are absolutely impervious to agents causing secondary contamination.**

## **SUITABLE MATERIALS AND EQUIPMENT FOR PACKAGING MEAT AND MEAT PRODUCTS**

**Packaging films can be subdivided into *cellulose films*, *plastic films* and *aluminium foil*. They can either be used as monofilms or as two or more different films laminated together. These materials differ in:**

- **oxygen permeability;**
- **water vapour barrier;**
- **resistance to hot and cold temperatures; and**
- **mechanical strength.**

**Nearly all available films are of thermoplastic materials, and therefore *heat sealable*, resulting in hermetically sealed plastic**

## **pouches, bags, etc.**

**A high oxygen barrier is important in the application of films for packaging meat and meat products. Films made of polyvinylchloride (PVC), polyethylene (PE) or polypropylene (PP) have a relatively high oxygen permeability, whereas polyvinylidenechloride (PVDC), polyester (PETP), polyamide (PA) and cellulose film (ZG) are less or almost non-permeable to oxygen. The latter materials are therefore better suited for packaging meat and meat products. However, the materials of the first group are frequently used as laminates with materials of the second group in order to achieve special effects regarding mechanical strength, heat sealing properties or making the package practically impermeable to both oxygen and water vapour.**

**For the efficient utilization of these materials, air must be drawn out completely from the packages with the meat product**

**(“vacuum-packaging”) and the package should be hermetically closed by heat sealing or metal clip. Vacuum-packaging will inhibit the growth of yeasts, moulds, and most aerobic bacteria under refrigeration temperatures. However, facultative anaerobes such as acid-producing bacteria grow freely under adequate  $a_w$ -conditions. These micro-organisms do not threaten the health of consumers but may affect the quality of the products by negatively influencing colour and taste. Therefore efforts should be made to keep the initial number of bacteria low, which can be obtained by simple hygienic measures during cutting and packaging, such as frequent handwashing, clean tools and clean tables.**

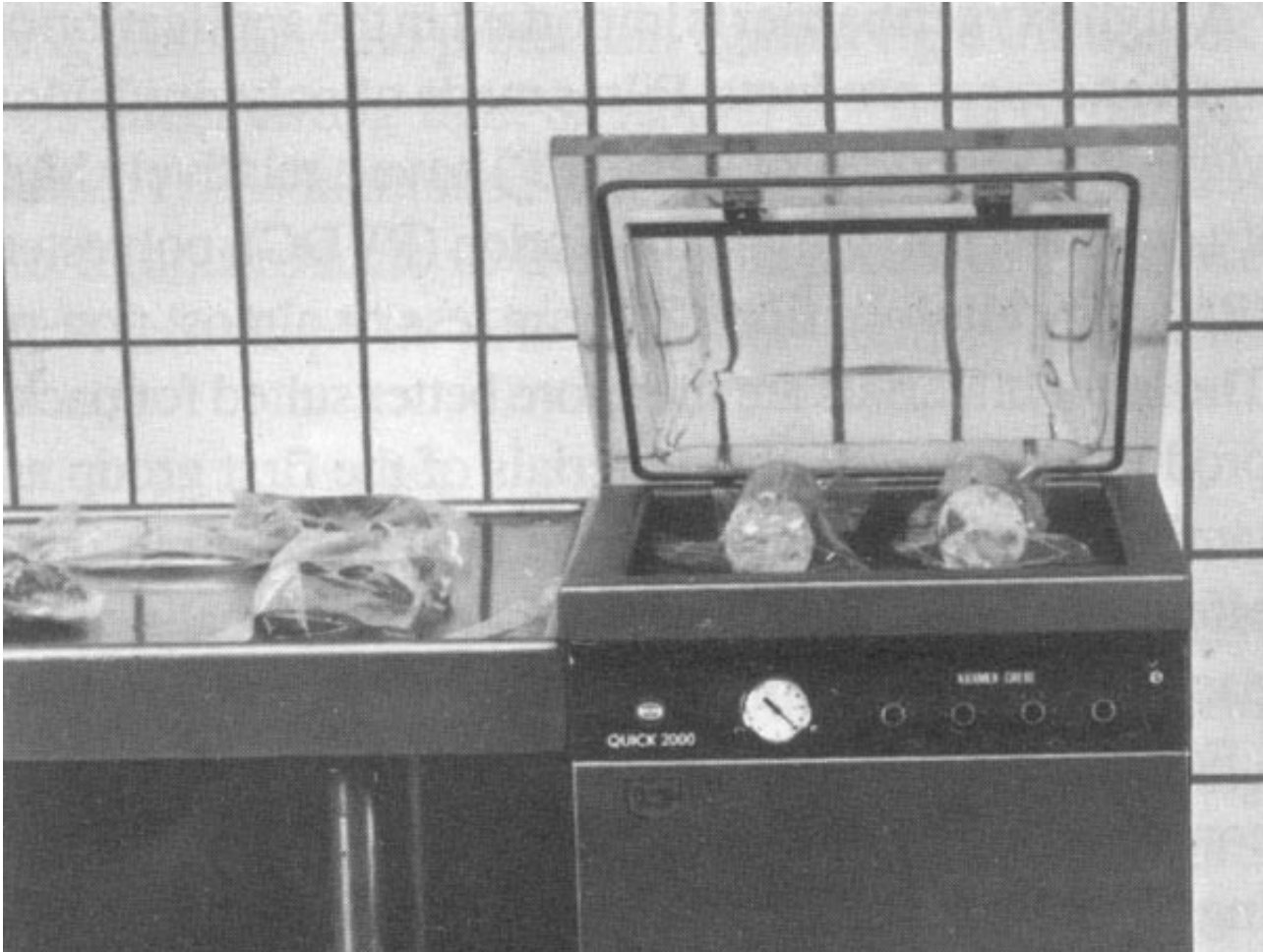
**The above general considerations refer to vacuum-packaged meat and meat products with a high moisture content. The situation is different for the traditionally preserved meat and meat products described in Chapter 2. All these products are shelf-stable because of their low water activity and therefore do**

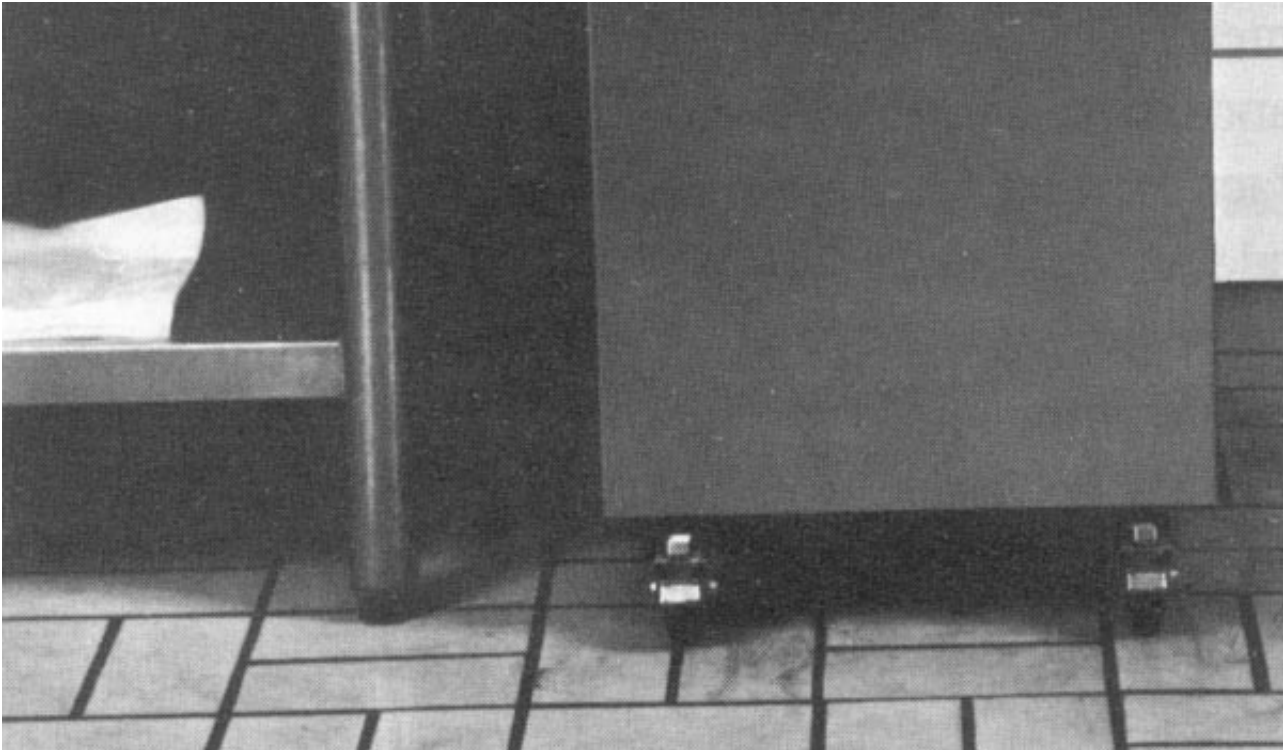
**not require refrigeration. They are partly dried in the sun, or others are dried and smoked over a wood fire.**

**These low-moisture products are hygroscopic and should be protected in the case of high air humidity. Traditional wrapping methods using paper, jute or linen will not inhibit the penetration of water vapour. However, a simple polyethylene bag is sufficient as a water vapour barrier, but care must be taken that the bag is tightly closed. If plastic bags are used for packing, then the pieces of dry meat should be cut to a certain length so that they can be better arranged in the bags. The bag should be bound with rope, rubber or cellotape. Bags stuffed with meat in this way are best stacked into a carton.**

### **FIG. 32.**

**Vacuum chamber machine. Lid is opened after evacuating and heat sealing of packages containing meat cuts and pieces of sausage.**





**Longer storage times for traditionally preserved dried meat can be achieved with vacuum-packaging in laminated films, which protect against humidity and oxidation by oxygen from the**

**atmosphere. Vacuum-packaging can also gain importance for traditionally preserved products. Although they are shelf-stable, exposure of these products to oxygen and the humidity of the surrounding atmosphere will cause unfavourable alterations (rancidity, loss of flavour, growth of certain micro-organisms) over the long term. Air and vapour-tight packaging will ensure a prolonged shelf-life.**

**Simple vacuum-packaging machines, suited to less developed regions, are available (Fig. 32). They consist of a chamber with a removable lid, so that the plastic pouch or bag containing the product can be placed inside the chamber, which is evacuated with an electrically driven vacuum pump. By closing the lid, air can be drawn out of the chamber and also out of the open bag. While still in the vacuum chamber, the bag is hermetically closed by heat sealing by means of a manual or automatic electrically heated sealing device. After being sealed the bag can be exposed to ambiental conditions without air penetrating the package.**



---

## 5. Basic methods of quality control

The quality of meat and meat products is defined by the following criteria:

- **palatability (typical texture and consistency, juiciness, good flavour);**
- **proportion of lean meat to fat;**
- **freshness and adequate conservability of the products;**
- **absence of harmful micro-organisms or substances; and**
- **appropriate (preferably minimal) use of additives and meat extenders.**



**The different criteria need different methods of quality control, such as:**

- **organoleptic evaluation**
- **physical test methods**
- **chemical analysis**
- **microbiological examination**

**According to the accuracy needed, the control method applied can be simple or more complicated and different auxiliary technical devices must be used.**

**In order to inform consumers and meat processors about the quality of meat and meat products, simple and fast control methods are best suited in many cases, although exact details on residues, toxins and special food components can only be obtained through specialized laboratories.**

**Basic methods for quality control must involve little or no equipment and obviously sensory evaluation will be most important. Some physical tests, however, can easily be performed using simple instruments such as thermometers, manometers, scales, etc.**

**By contrast, chemical and microbiological tests are more complicated. These methods not only require standard equipment but also skilled and experienced personnel to do the tests and to interpret the results.**

**The following mainly refers to the basic methods of quality control used in connection with the handling and processing of meat. These control methods can easily be applied for meat products processed with simple meat preservation techniques.**

## **ORGANOLEPTIC EVALUATION**

**Organoleptic evaluation consists in describing the attributes of food, in this special case of meat and meat products, that can be perceived by the sense organs. The attributes to be evaluated are appearance, colour, texture and consistency, smell and taste.**

## **Appearance**

**The way meat looks, either as a carcass or as boneless meat cuts, has an important impact on its objective or subjective evaluation. Grading is an objective evaluation method in this context. Traditional methods of carcass grading after slaughter involve the aspect of beef or pork sides, poultry carcasses, etc. Skilled graders are able to classify different carcasses by checking the size, the volume of muscular tissue, fat layers, etc. Although in modern grading procedures more and more technical equipment has been incorporated, visual methods are still in use. They can be of special value in most developing countries where no extremely sophisticated methods are needed.**

**The way the consumers or the processors check the appearance of meat is subjective. Differences will be registered in the relation of lean meat and fat including the degree of marbling or in the relation of bones and lean meat. Furthermore, unfavourable influences can be detected such as unclean meat surfaces, surfaces too wet or too dry, or unattractive blood splashes on muscle tissue.**

**Processed meat, on the other hand, can roughly be evaluated by its appearance according to the different raw materials of which the product is composed and where the use of some components is exaggerated (for instance too many particles of visible fat or connective tissue, etc.). Special product treatments (for instance chilling, freezing, cooking, curing, smoking, drying) or the kind and quality of portioning and packaging (casings, plastic bags, cans) will be recognized by evaluating the appearance.**

## **Colour**

**Under normal circumstances the colour of meat is in the range of red and may differ from dark red, bright red to slightly red; but also pink, grey and brown colours may occur. In many cases the colour indicates the type and stage of the treatment to which the meat has been subjected, as well as the stage of freshness.**

**In judging meat colour, some experience is needed to be able to distinguish between the colour which is typical for a specific treatment or which is typical for specific freshness. Furthermore, meat deriving from different species of animals may have rather different colours, as can easily be seen when comparing beef, pork and poultry meat.**

**The natural colour of fresh meat, except poultry meat, is dark red, caused by the muscle pigment, myoglobine. Fresh meat surfaces which have been in contact with the air for only a short**

**period turn into a bright red colour because of the influence of the oxygen in the air. Oxygen is easily aggregated to the myoglobine and drastically changes the colour of the meat surfaces exposed to it. On the other hand, in the absence of oxygen, for example in meat cuts packaged in impermeable plastic bags, meat surfaces remain or become dark red again. The same conditions generally prevail in the interior of meat cuts which are not reached by oxygen. Changes from dark red to bright red are therefore typical and are normal reactions of fresh meat.**

**Meat which is in the process of losing its freshness, however, no longer shows a bright red colour, even when intensively exposed to the air, because of the partial destruction of the red meat pigment which results in a grey, brown or greenish colour. Once these conditions occur the consumer has to decide, after carefully checking the appearance, together with testing smell and taste, whether the meat has to be discarded as a whole or**

**whether use can be made of some parts which so far have not been altered.**

**Remarkable changes in the meat colour occur when fresh meat has been boiled or cooked. It loses its red colour almost entirely and turns to grey or brown. The reason for this is the destruction of the myoglobine through heat treatment. On the other hand, it has long been known that after pickling (curing) fresh meat with curing ingredients (nitrite), the meat colour remains red during longer storage periods, after ripening, drying and even after intensive heat treatment. Obviously the original meat colour has not been conserved, but a chemical reaction has taken place during the curing process transforming the unstable pigment of the fresh meat into a stable red pigment. This is the typical colour shown in sausages of all types, raw and cooked hams, corned beef, etc.**

**It should also be noted that cured products have a longer shelf-**

**life than fresh meat because of the conserving effect of the curing salt. However, cured products will also deteriorate under unfavourable conditions, cooked cured products sooner than raw cured products. Cured products with a decreasing keeping quality can be recognized when the red colour becomes pale or changes to grey or green.**

### **Texture and consistency (tenderness and juiciness)**

**Meat prepared for the consumer should be tender and juicy. Meat tenderness depends on the animal species from which the meat originates. Lamb, pork and poultry meat are sufficiently tender after slaughter, but beef requires a certain period of maturation to achieve optimal eating quality.**

**Texture and consistency, including juiciness, are an important criterion, still neglected by many consumers, for the eating quality of meat. Often consumers do not know that the eating**



**quality of meat can be upgraded by ripening, especially in the case of beef and similar meats. There is also a great deal of consumer negligence in how to prepare meat. It should be cooked to become sufficiently tender, but cooking should not be too intense otherwise the meat becomes dry, hard and with no juiciness.**

**The simple way to check the consistency of foods is by chewing. Although this test seems easy, in practice it is rather complicated. Taste panelists need experience, particularly when the different samples have to be ranked, for example which sample is the toughest, the second toughest or the most tender.**

**The texture is of less importance in meat products, such as cured or canned products, sausages, etc., because they are either made of comminuted meat and/or meat which has undergone heat treatment or long maturation periods and will therefore generally be tender. On the other hand, inadequate**

**processing methods (too intensive cooking, curing, comminuting) may cause losses in the desired consistency and juiciness, and the best way to check this is by chewing.**

### **Smell and taste (aroma and flavour)**

**These characteristics are related to each other to a certain extent because they have to be evaluated together for the reliable determination of a product's flavour. The smell of fresh meat should be slightly acidic, increasing in relation to the duration of the ripening period because of the formation of acids such as lactic acid. On the other hand, meat in decomposition generates an increasingly unpleasant odour owing to substances originating from the bacterial degradation of the meat proteins, such as sulphur compounds, mercaptane, etc.**

**The freshness of meat is generally indicated by its smell together with its appearance and colour. Sorting out deteriorated meat is**

**mandatory from the point of view of the product's palatability. It is also important because of the fact that high bacterial contamination of meat in decomposition could be accompanied by food-poisoning bacteria(pathogens), which have a deleterious impact on consumers' health. On the other hand, the best fresh meat can also be heavily contaminated with food-poisoning bacteria because these micro-organisms do not cause organoleptic alterations by destruction of meat proteins. Food poisoning can therefore only be avoided by proper hygienic meat handling. The flavour of fresh meat can also be checked by putting small samples (approx. 10 pieces of 1 cm<sup>3</sup> each) in preheated water of 80°C for about five minutes (boiling test). The odour of the cooking broth and the taste of the warm meat samples will indicate whether the meat was fresh or in deterioration or subject to undesired influences, for instance rancidity of the meat fat, any a typical meat flavour due to the feed and the sex (boar taint) of the animal or treatment with**

## **veterinary drugs shortly before slaughter.**

**When processing the meat, the smell and taste of the meat products can differ a great deal owing to heat treatment and the use of salt, spices and food additives. Every meat product has its typical smell and taste, and the test person should know about it. Changes in these qualities indicate the use of improper raw materials or a deterioration of the meat product during storage.**

**Experience is required to become acquainted with the typical flavour (smell and taste) of foods. Only four basic taste components--sweet, sour, bitter and salty--will be perceived by the taste buds. These receptors are small papillae located in certain areas of the tongue. However, the overall flavour consists of smell and taste produced by the meat components and influenced and covered by spices and those compounds produced by ripening or heat treatment. Flavour test panelists should be aware of these special cases. Panelists should not**

**smoke or eat spicy meals before starting the test and should rinse their mouth frequently with warm water during the test.**

**Sensory evaluation plays an important role in the examination of meat and meat products. Not only does scientific sensory evaluation with skilled panelists using special test programmes and point systems give reliable results, but useful results can also be obtained in a simple way at the consumer level. For the average consumer sensory evaluation is the only way to decide whether or not he or she should buy or eat a certain product.**

**In developing countries consumers do not receive sufficient information and training on this point, although it is often the only means available for quality control. Sensory evaluation is easy to understand and to perform. What is needed is a basic knowledge of the composition of foods and their typical texture, colour and flavour.**

## **PHYSICAL TEST METHODS**

**Physical test methods focus either on the actual condition of meat and meat products, or on the conditions around the product, for example in storage rooms, packages, etc. Equipment will be needed for all these tests which is easily applicable and resistant to utilization under the conditions of practical meat handling and processing.**

### **Temperature**

**Storage of meat and meat products requires low temperatures to make sure that the growth of micro-organisms will be retarded (chilling between -1 to +4°C) or inhibited (freezing preferably in the range of -18 to -30°C).**

**Cooking of meat requires high temperatures (starting from a temperature of about 55°C needed for denaturation, but generally**

**higher temperatures are applied, up to 100°C).**

**Canning of meat requires temperatures above 100°C, and for sterilized products where all micro-organisms are inactivated, at least 121°C.**

**These examples demonstrate the importance of different temperatures for different purposes and the necessity of exact temperature measurements using thermometers or temperature recorders.**

**Glass thermometers should not be used in direct contact with meat because they may break, leaving undesired fragments in the meat, but they are useful when permanently fixed to walls of chillers or production rooms or to cooking equipment or autoclaves for easy checking of the relevant temperatures.**

**Mechanical bimetal-thermometers, utilizing the extension or**

**contraction of a bimetal spiral under various temperatures, are not very accurate and not sufficiently shock-resistant for practical work in meat industries. Nevertheless, they are widely used and can serve for rough estimates.**

**Electrical thermometers (Fig. 33), consisting of a sensor and a battery-powered electronic instrument, are well suited for meat industries. The sensor functions as a semiconductor. Under different temperatures, differences in the electric conductivity of the sensor are produced. The temperature which the sensor takes up by contact to the surrounding media (water, air, meat, etc.) produces a certain voltage in the electric system. This voltage is registered and displayed as a digital reading of the actual temperature on the instrument.**

**FIG. 33.**

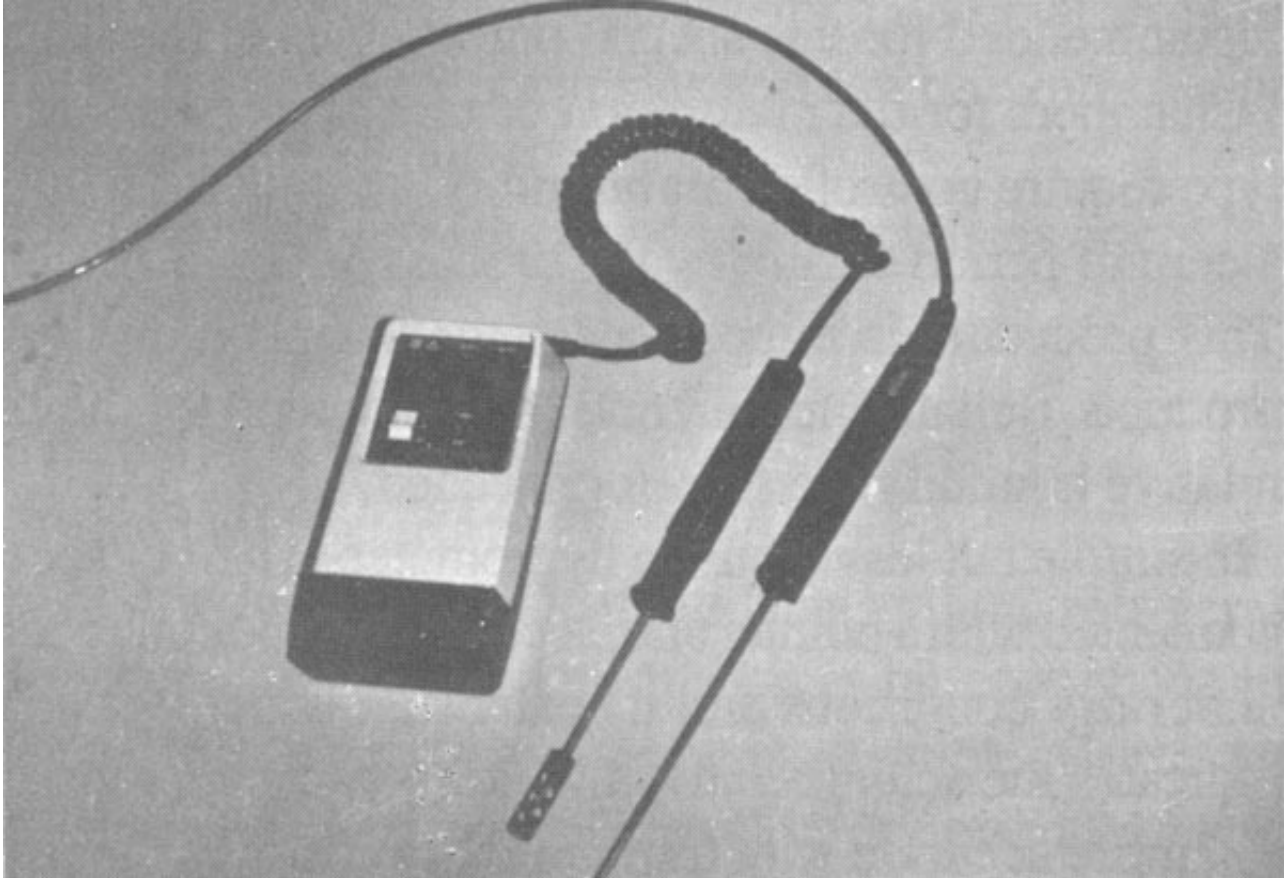
**Electrical thermometer with digital display and two sensors for measuring air temperature (left) and the temperature of meat,**



04/11/2011

Manual on simple methods of meat pr...

**liquids, etc. (right).**



## **Advantages of modern electronic thermometers are:**

- **no glass or other parts that can easily break;**
- **the sensor can be easily pushed deep into the meat, as well as into frozen meat, and is also heat-resistant under sterilization temperatures;**
- **display of the correct temperature within seconds;**
- **no frequent calibration necessary;**
- **a wide range of temperatures can be covered using one instrument (the temperature range of the instruments recommended for use in meat industries should be between +140°C and -40°C); and**
- **accurate temperature measurement, also in decimals.**

## **Humidity**

**In some special field of meat processing and storage, air humidity is of importance.**

**In cutting rooms the humidity of the air should be below the level which would cause vapour condensation on the surfaces of the meat being deboned and cut. Vapour condensation may enhance bacterial growth.**

**Storage chillers for fresh meat require a balanced air humidity that does not cause wet surfaces on the meat with resulting accelerated bacterial growth, but on the other hand keeps evaporation losses low. The relative humidity recommended for this special purpose lies in the range of 70 percent.**

**Chambers for the maturation of raw hams or dry sausages of the salami type require controlled air humidity, starting from 90–95 percent and after a certain period finalizing the process at 70–75 percent relative humidity. This procedure is important for the balanced drying and ripening of the products. Suitable instruments (hygrometers) for the exact measurement of relative humidity are therefore needed.**

**In simple but less accurate hygrometers a hair or special synthetic fibre is connected with a pointer and, according to the contraction of the hair or fibre under dry conditions and its extension under wet conditions, the pointer indicates the actual relative humidity on an appropriate scale.**

**A more accurate way for humidity control is the psychrometric system. These instruments use a dry and a wet sensor to define the ambiental temperature. The temperature indicated by the wet sensor will always be lower, in this case, because of evaporative cooling. The drier the air, the more intensive evaporative cooling will be. Using both temperature values (dry and wet temperature), the value of the relative humidity is determined in practical work using a table for easy calculation.**

**A modernized psychrometric system which uses electronic devices is available. In this case the humid sensor has not actually to be kept wet, but consists of hygroscopic material with**

**altering electrical resistance. The relative humidity calculated from the temperatures delivered by the sensors by means of a micro-processor is directly displayed on the instrument (Fig. 34).**

## **Water activity ( $a_w$ )**

**Water activity is the free water available for microbial growth in a food product. Free water is that part of the water content that can be eliminated from the product in the form of water vapour. Hence, the term “water activity” is defined as the ratio of the water vapour pressure measured in the product and the pressure of a saturated water vapour atmosphere at the same temperature. This physical definition is used in connection with a number of meat products whose keeping quality depends on their water content. Micro-organisms need a certain degree of moisture to be able to grow on foods. The minimum moisture content necessary for microbial growth varies with the single species of micro-organisms and can be expressed in terms of**

## **minimum water activity required.**

**The lowest  $a_w$ -values permitting growth of spoilage organisms are:**

- **normal bacteria 0.91**
- **normal yeasts 0.88**
- **normal moulds 0.80**
- **halophilic (NaCl-tolerant) bacteria 0.77.**

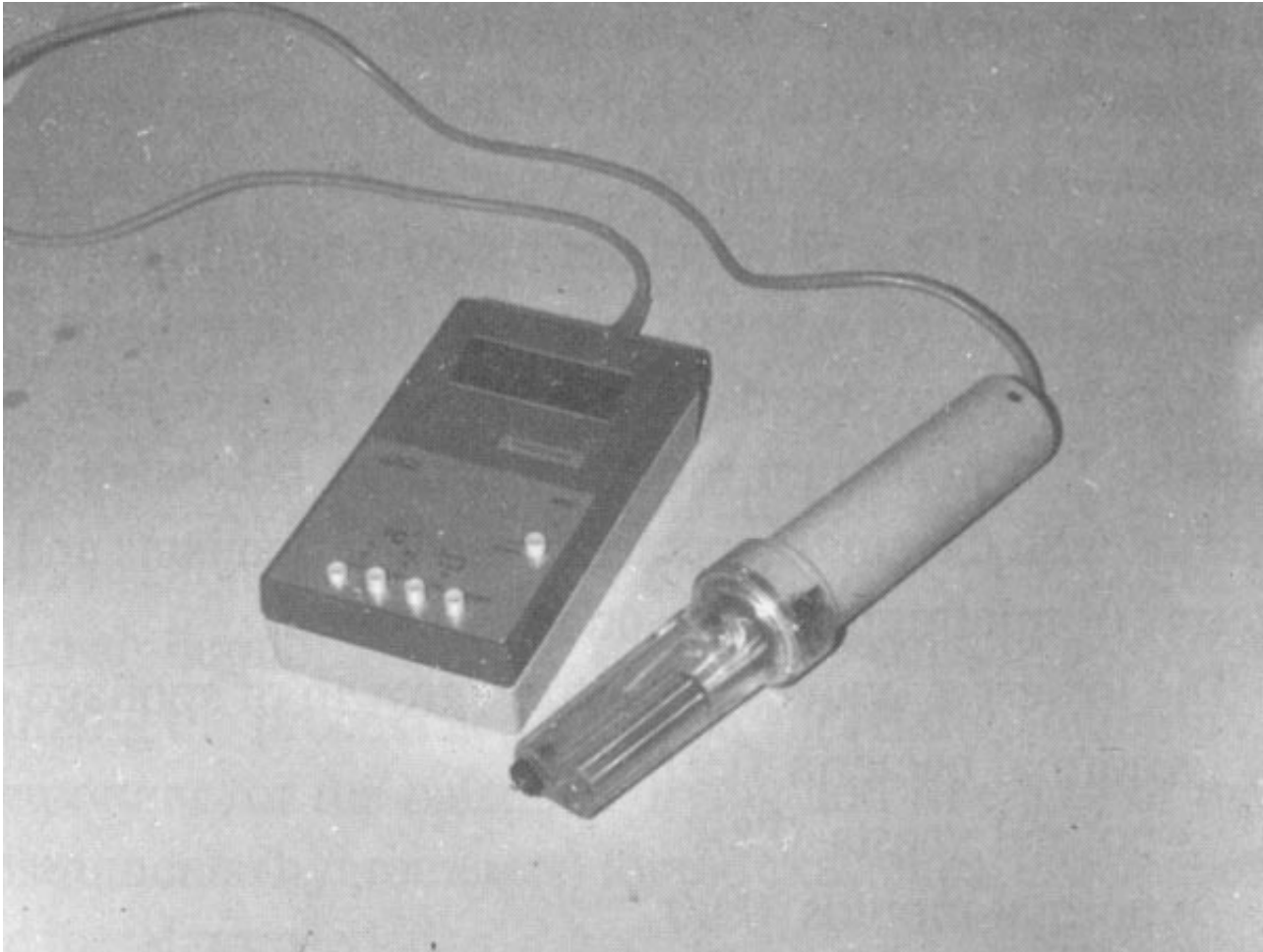
**The keeping quality of dried meats and meat products without refrigeration depends on their water activity. Dried meat such as biltong, charque, etc. reaches a sufficiently low water activity to be shelf-stable. However, water activity should decrease as fast as possible as slow drying could cause deterioration in a prolonged phase of the process with a still high water activity. The situation is more complicated in the case of products which cannot be dried too intensively such as dry sausages or raw**

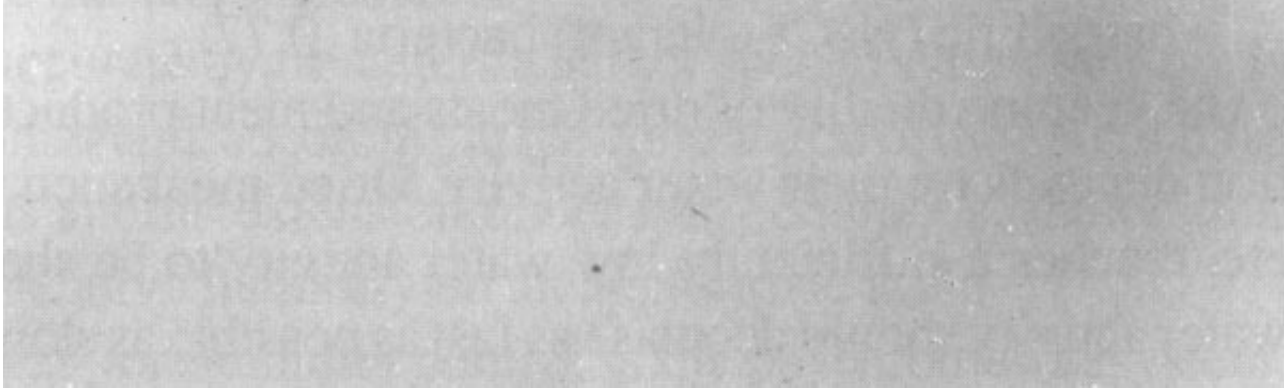
**hams. The water activity of these products is relatively low but would still allow the growth of some undesired micro-organisms. Under these circumstances an appropriate shelf-life has to be ensured by the combination of several inhibiting factors, i.e. water activity, content of salt and curing ingredients and the acidity of the product.**

**Information on the water activity of certain products can be important for further handling, packaging and storage. Simple methods for the determination of water activity are therefore useful.**







**FIG. 34.**

**Electronic psychrometer (hygrometer) and sensor (right) for direct measurement of the relative air humidity.**

**As water activity refers only to the water available for microbial growth in a product, the chemical analysis of the total moisture content is of limited value since it would also include the water bound by the proteins. The proper way to determine water activity is to measure the humidity of the remaining air in a hermetically closed small cabinet which is to a certain extent**

**filled with the product sample. After a short time a hygroscopic equilibrium between the sample and the surrounding air will be reached. Thus, the humidity determined in the air is equivalent to the humidity available in the product and water activity can be calculated.**

**For the measurement of air humidity under these conditions, the same principles apply as previously described. Simple devices utilize the extension or contraction of hairs or synthetic fibres, and more sophisticated and more expensive systems use electronic devices.**

**The sample is placed in the bottom part of the tin and then the lid of the tin that contains the device to measure the humidity is hermetically screwed on. After two hours, hygroscopic equilibrium is reached in the can and the reading of the instrument corresponds to the actual water activity of the product, provided the test has been carried out at a temperature**

**of exactly 25°C. If this temperature cannot be maintained, corrective calculations will be necessary.**

**Some examples for values of water activity ( $a_w$ ) of different products are shown:**

fresh raw meat	0.99–0.98
cooked ham	0.98–0.96
frankfurter-type sausages	0.98–0.93
liver sausage	0.97–0.95
raw cured ham	0.96–0.80
dry sausage (salami type)	0.96–0.70
dry meat	0.75–0.50

**A certain number of micro-organisms are inhibited at  $a_w$  0.95, but other species are still able to grow. At  $a_w$  0.92 all bacteria groups are inhibited, but the growth of moulds and yeasts is still**

**possible.**

## **Airtight closure of cans**

**For shelf-stable canned meat products two aspects are important from the microbiological standpoint. During sterilization, microorganisms and their spores have to be inactivated and the can must be hermetically sealed to avoid further contamination of the product after sterilization.**

**Invisible small perforations of the tinplate or small defects after the closure of the lid will inevitably lead to a *recontamination* by penetrating bacteria and after a short time spoilage of the canned product will occur. Cans should therefore be checked from time to time for these defects.**

**A simple method is available for this purpose. Using an air-pump with a special device to penetrate the tinplate, the air is pumped**

**into a closed but empty can (Fig. 35). The internal pressure built up in the can can be controlled by a manometer connected with the air pump. When dipping the inflated can into water it can easily be seen whether the can is hermetically sealed and if not where the cause for the permeability is, either in the prefabricated body (side wall and bottom) of the can or in the area of the lid seam. In the latter case the function of the can-closing equipment in the processing plant has to be thoroughly checked.**

## **Weight differences**

**The high water content of meat (approx. 70 percent) and meat products (which varies from 70 percent to 10 percent) causes weight differences owing to evaporation losses or drip losses that occur during handling, processing or storage.**

**Unpackaged meat and meat products are especially subject to**

**considerable evaporation losses. During chilling of warm carcasses evaporation losses of 1 to 2 percent cannot be avoided but further evaporation losses of chilled or frozen meat should not occur when suitable storage conditions (not too dry) or suitable packaging (plastic bags, containers, boxes) are employed. However, some drip losses of packaged meat cannot be avoided.**

**During meat processing weight losses of meat by cooking, frying or other heat treatment can be registered and reach high values (up to 30 to 35 percent). These losses are unavoidable.**

**On the other hand, some meat products require weight losses by evaporation to reach their specific keeping quality, for example raw hams, dry sausages or dried meat. In this case, water activity as previously described plays an important role.**

**Information on weight losses in meat handling and processing is**

**important from the economic and technological point of view. Weight losses can easily be determined using scales of different types, such as suspension scales for carcasses or batches of products and horizontal scales for packages or portions.**

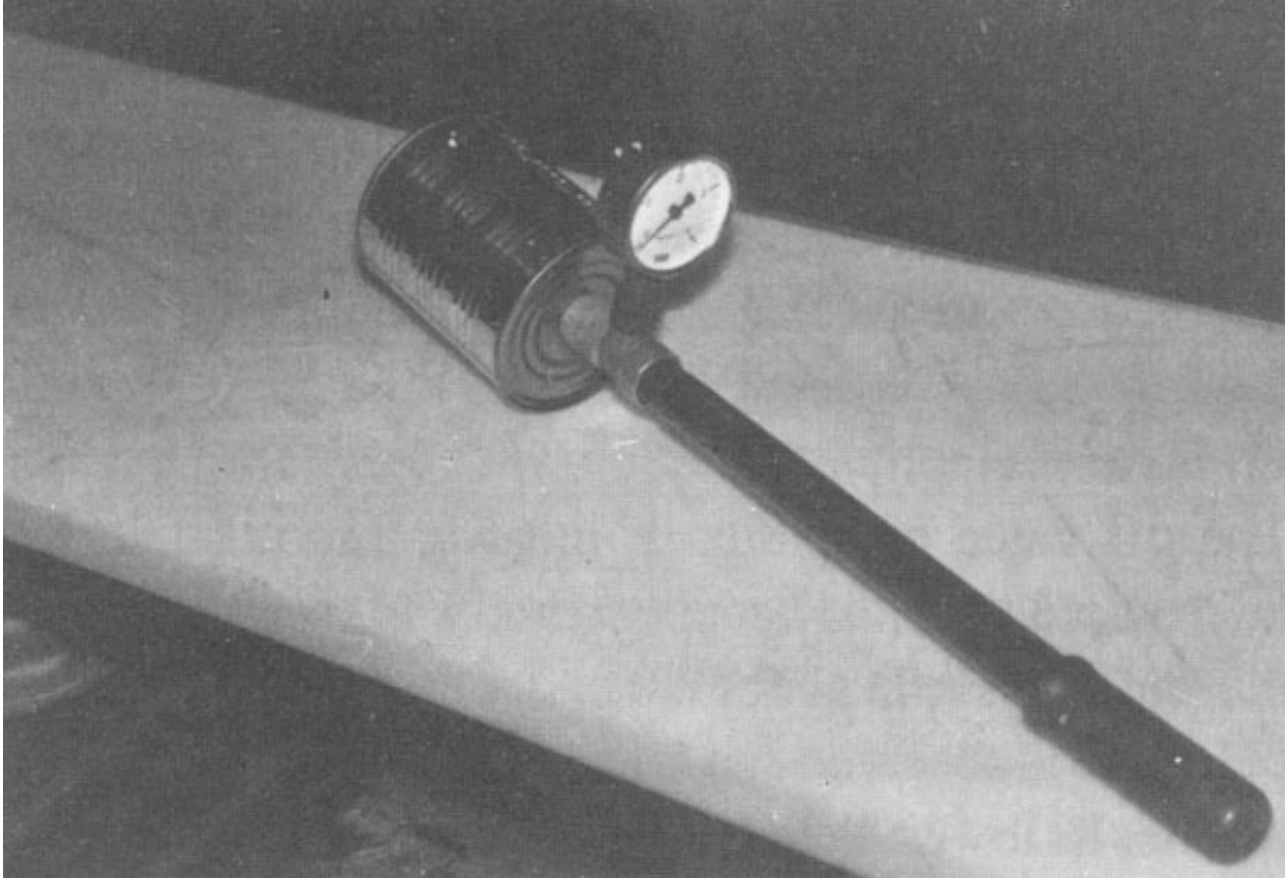
### **Salt concentration in brines**

**In addition to dry curing methods (dry salt and curing ingredients on the meat), brines are also used for pickling and curing the meat. Brines contain salt and in most cases also sugar and nitrite dissolved in water. With this curing process, meat is either immersed into a brine or the brine is injected into the meat with special devices. In both cases salt is a limiting factor for the sensory quality of the products; in other words salt is needed but should not exceed 2.5 to 3 percent in cooked cured products and 4.5 to 5 percent in raw cured and dried products.**

**To comply with these requirements, simple methods for testing**



**salt concentration in brines are necessary. For this purpose salimeters have proved to be a useful piece of equipment. Salimeters are densimeters, the graduation showing salt concentrations. Salimeters are dipped into the brine and according to a lower or higher salt content they sink deeper or less deep into the brine. The reading of the salimeters at surface level indicates the salt concentration of the brine. The various technologies of meat curing use brines with NaCl-concentrations in the range of 8 to 22 percent.**



**FIG. 35.****Mechanical instrument to prove airtight closure of cans.****OTHER PHYSICAL TEST METHODS**

The physical test methods which have been described can easily be performed since the use of the technical equipment necessary is not too complicated. Other physical test methods exist too, for example, light intensity measurement, colour measurement or texture and consistency measurements of meat and meat products. These tests require rather complicated and expensive instruments and skilled technical personnel. For routine work, criteria such as light, colour, texture and consistency can be evaluated in a satisfactory way by using the corresponding sensory test methods.

**Chemical analysis**

**Chemical characteristics of foods are related to the product itself and refer primarily to the content of specific substances, which are important from the point of view of keeping quality, flavour, nutritional value, etc., or which may also represent harmful residues.**

**The test methods necessary are generally complicated and need sophisticated equipment. However, there are also some simple and quick methods for chemical testing with sufficient accuracy which can be applied in the daily routine work such as pH-measurement, moisture/fat/protein determination and various screening methods utilizing test paper strips.**

### **pH-measurement**

**The pH-value or acidity of meat is important in relation to the meat's microbiological and keeping quality. In the live animal the pH-value of the muscular tissue is about 7.0 to 7.1. Very soon**

**after slaughter a drop in the pH-value is observed and after several hours (24 hours or less) the pH-value reaches its lowest level of about 5.6 to 5.8. The increasing acidity is because of the post-mortem formation of lactic acid from glycogen, a sugar-like substance stored in the live animal's muscles for energy supply.**

**In meat lactic acid causes a decrease in pH-value which is favourable for keeping quality (low pH inhibits bacterial growth) and for flavour (acidity is one of the components of meat flavour). However, the pH of meat is not uniform either in different carcasses or in different muscles of one carcass. Physiological oscillations do not greatly harm meat quality but abnormal reactions in meat are of great economic, hygienic and technological impact.**

**There are two types of abnormal reaction with regard to the pH in meat. First the pH-value may drop too fast and second it may not reach the normal low level several hours after slaughter, but**

**remain in the range of 7.**

**Both abnormalities can easily be detected by pH-measurement in the meat. A too fast pH-value decrease is evident, when one hour after slaughter low pH-values in the range of 5.6 to 5.8 are already reached. This phenomenon occurs only in pigs and the meat remains pale, soft and exudative (PSE). Because of its paleness and wetness (low water-holding capacity), this meat should *not* be used for ham and sausage manufacture (gives dry, tasteless products).**

**An insufficient decrease of the pH-value, which occurs both in pork and beef, is of hygienic significance because of the lack of building up a certain degree of acidity and suppressing microbiological growth. This meat also remains close to pH-value 7 after several hours, and is dark, firm and dry (DFD). It should not be used for meat and meat products which have to be stored over a longer period, such as vacuum-packed meat cuts, dry**

**sausages of the salami-type or cured raw hams. However, it is well suited for cooked meat products because of its extremely good water-holding capacity.**

**It can be seen from this that the pH-measurement is of particular importance for the selection of the raw material for meat processing purposes. Hence, portable electric pH-meters are widely distributed and utilized in the meat industry (Fig. 36).**

**The pH is measured on meat surfaces or in the meat itself, in the latter case by pushing the sensor into the muscle or by means of an incision using a knife. The sensor consists of a glass electrode filled with an electrolyte (solution of  $KCl$ ) and a sensitive glass membrane attached at the top.**

**Through the membrane the difference in the hydrogen-ion concentration, which corresponds to the acidity of the meat, is detected and digitally displayed on the attached instrument.**

**pH-measurement on meat can easily be performed but the following points must be considered:**

- **the electrode sensor must be completely filled with the electrolyte;**
- **the instrument must be adjusted daily (calibrated) using two buffer solutions with pH-values 4 and 7;**
- **after each measurement the electrode must be cleaned using distilled water;**
- **before each measurement the temperature of the meat, meat product, etc. must be checked and the instrument adjusted accordingly.**

## **Moisture/fat/protein determination**

**Information about the moisture, fat and protein content is essential for the evaluation of the quality of different meats and meat products. Determination methods have changed a great**

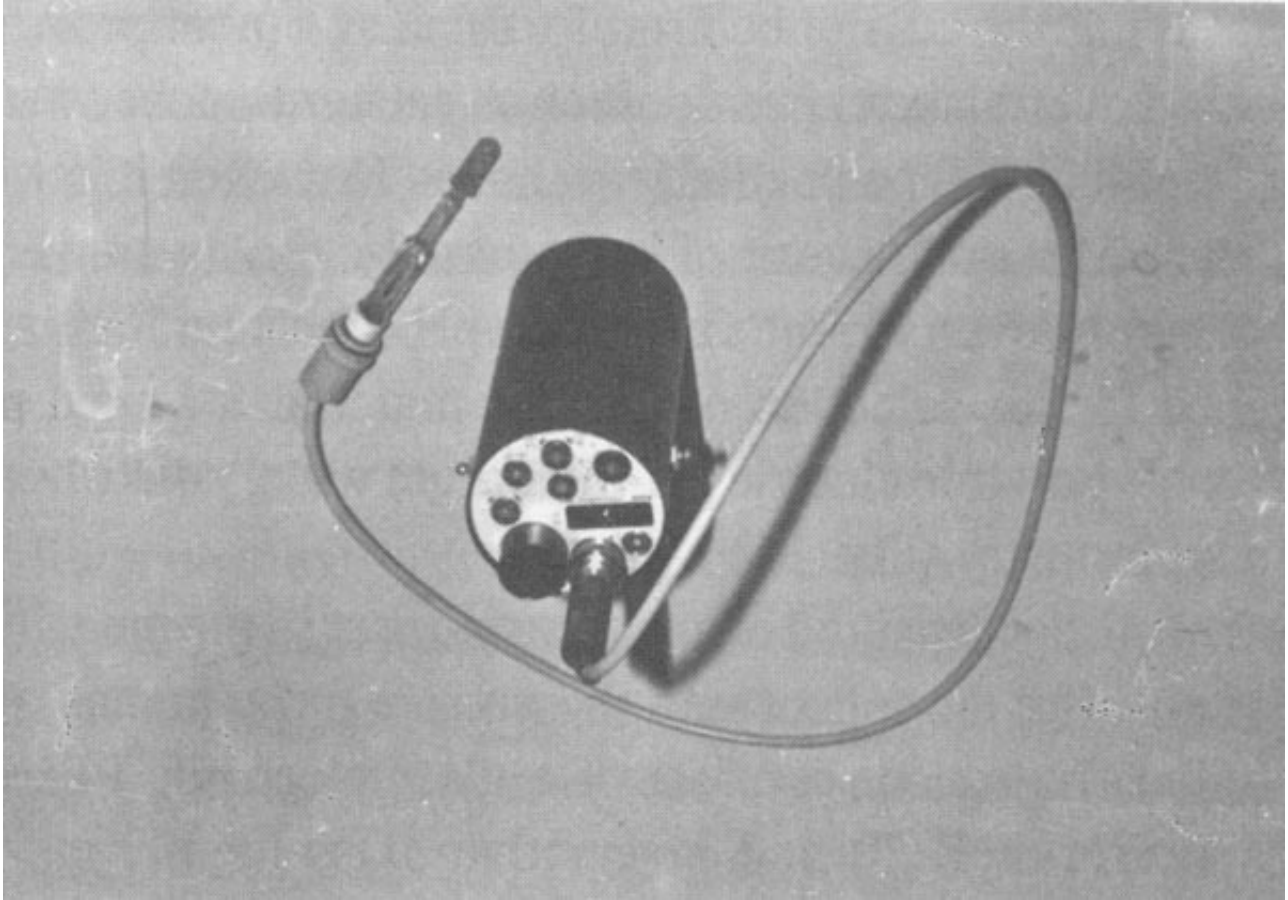


**deal in this field in recent years. Revolutionary techniques were introduced using X-rays, infra-red radiation or microwaves in automatic equipment for quick analyses of moisture, fat and protein. These modern methods are time-saving, the results are delivered within minutes or seconds and high numbers of samples can be tested. However, the equipment is expensive and therefore not suitable for small industries. For routine controls, where not necessarily highly accurate but reliable results on moisture, fat, protein and anorganic components (ash) are needed, cheaper and less complicated methods can be applied. A specially designed laboratory scale, together with some other devices, is required. After homogenizing and weighing the sample, it is fast dried using an infrared beam (or a microwave oven if available). The weight difference is equivalent to the product's water (moisture) content. The fat is then dissolved using a fat-extracting liquid and removed together with the liquid. The solvent is evaporated. The weight of the residue represents the fat content of the sample. Finally, the sample is charred in a**

**muffle furnace and the weight of the residue is the ash content. Since the sum of the percentages of moisture, fat, ash and protein must be 100, and since the percentage of moisture, fat and ash is known, the protein content in percent is calculated as follows: 100% minus the percent of moisture, fat and ash. This method is not precise, but it is fast, provides useful results about the composition of meat and meat products and can be applied without high costs.**

**FIG. 36.**

**Portable electric pH-meter with sensor (glass electrode). The glass electrode is protected by a removable cover of flexible synthetic material in order to avoid breakage and keep the diaphragm of the sensor humid.**



**For chemical evaluations a number of screening methods are also available using different test papers. The results are indicated by changes of the colour of certain areas on the paper strips. These test papers are used for pH-measurement, screening of the nitrite content and even for the screening of some harmful residues such as antibiotics. pH-measurements on meat with test strips are negatively influenced by the meat pigment making the colour determination often difficult and the pH-determination not very accurate.**

## **MICROBIOLOGICAL EXAMINATION**

**These control methods cannot be carried out without laboratory equipment, because they require sample preparation under sterile conditions, incubation of the samples under constant temperatures and sufficient microbiological knowledge on the part of the personnel involved to interpret the results. However, the application of microbiological methods is the only way to**

**obtain information about the hygienic status of places, equipment and foods. It is true that unclean conditions will always indicate high microbiological contamination and one could argue that a thorough cleaning-up rather than a further microbiological analysis would be needed in those cases. But there could also be the need of detecting the source of permanent contamination (for example through the water, movement of personnel, raw material delivered, etc.) or of food poisoning bacteria. Under these circumstances microbiological examinations can often be very helpful and solve immediate problems.**

**Some methods suitable for routine work should be mentioned.**

### **Trigger methods**

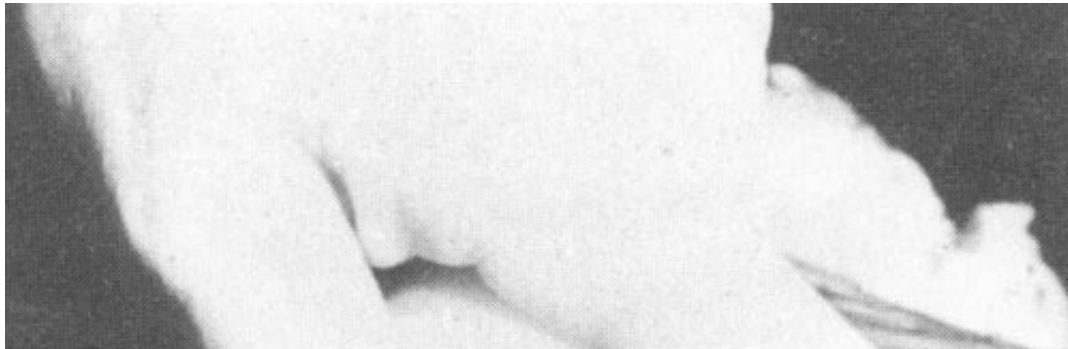
**Microbiological culture media in special small moulds are lightly pressed against walls, equipment (knives, machines), meat**

**surfaces or hands of personnel. The micro-organisms adherent to these objects are absorbed by the surface of the culture media, and after adequate incubation (one to two days at 30 to 37°C), microbial colonies can be identified and counted on the media. Each one of the colonies grown during incubation corresponds to one micro-organism which was on the object tested.**

**Instead of culture media a special sterile strip of cellotape together with a trigger can be used for taking samples from surfaces (Fig. 37). After that the cellotape is laid on a culture media for incubation. This procedure allows the utilization of one culture medium for the incubation of different samples at the same time (Fig. 38). However, there is one disadvantage with the trigger system. In the case of high bacterial contamination of the surfaces, tested bacterial colonies will grow very densely together and can no longer be counted.**

## Swab method

**Surface contamination related to a certain area can be sampled using a sterile swab. After rubbing the swab gently along the surface to be tested (Fig. 39), it is suspended on the surface of a culture media. In contrast with the trigger method, bacterial contamination can be spread over the whole surface (Fig. 40) which is important in the case of high contamination. Thus the samples can always be evaluated since the single colonies are not grown together (Fig. 41). However, the method lacks some accuracy since bacteria may remain in the swab.**



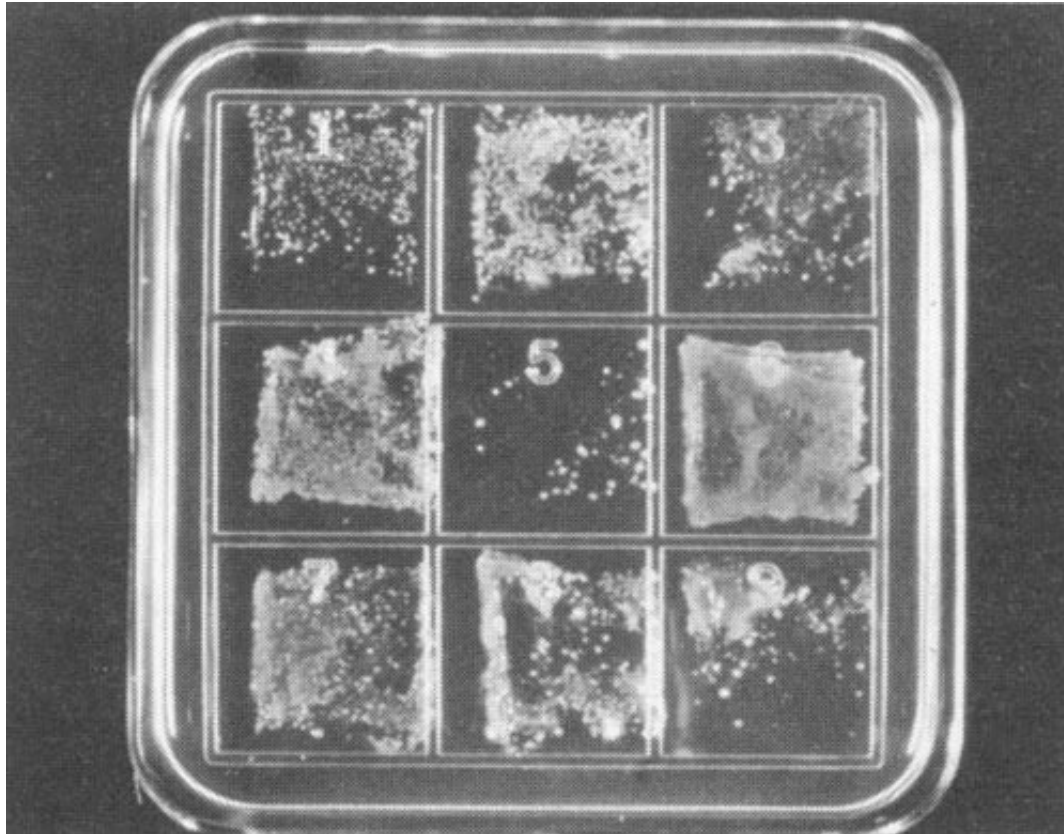


**FIG. 37.**

**Trigger and sterile cellotape for microbiological sampling of the**

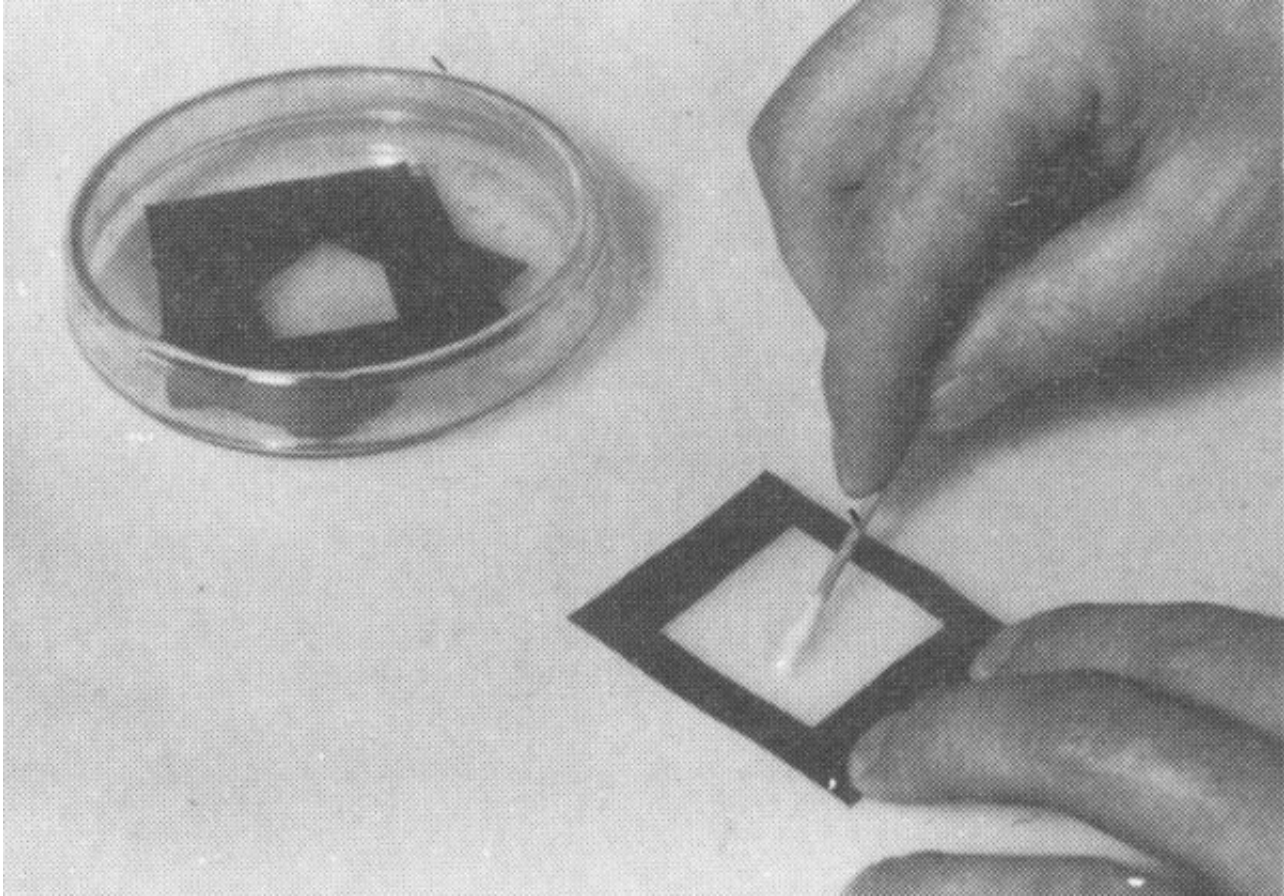


# meat surface.



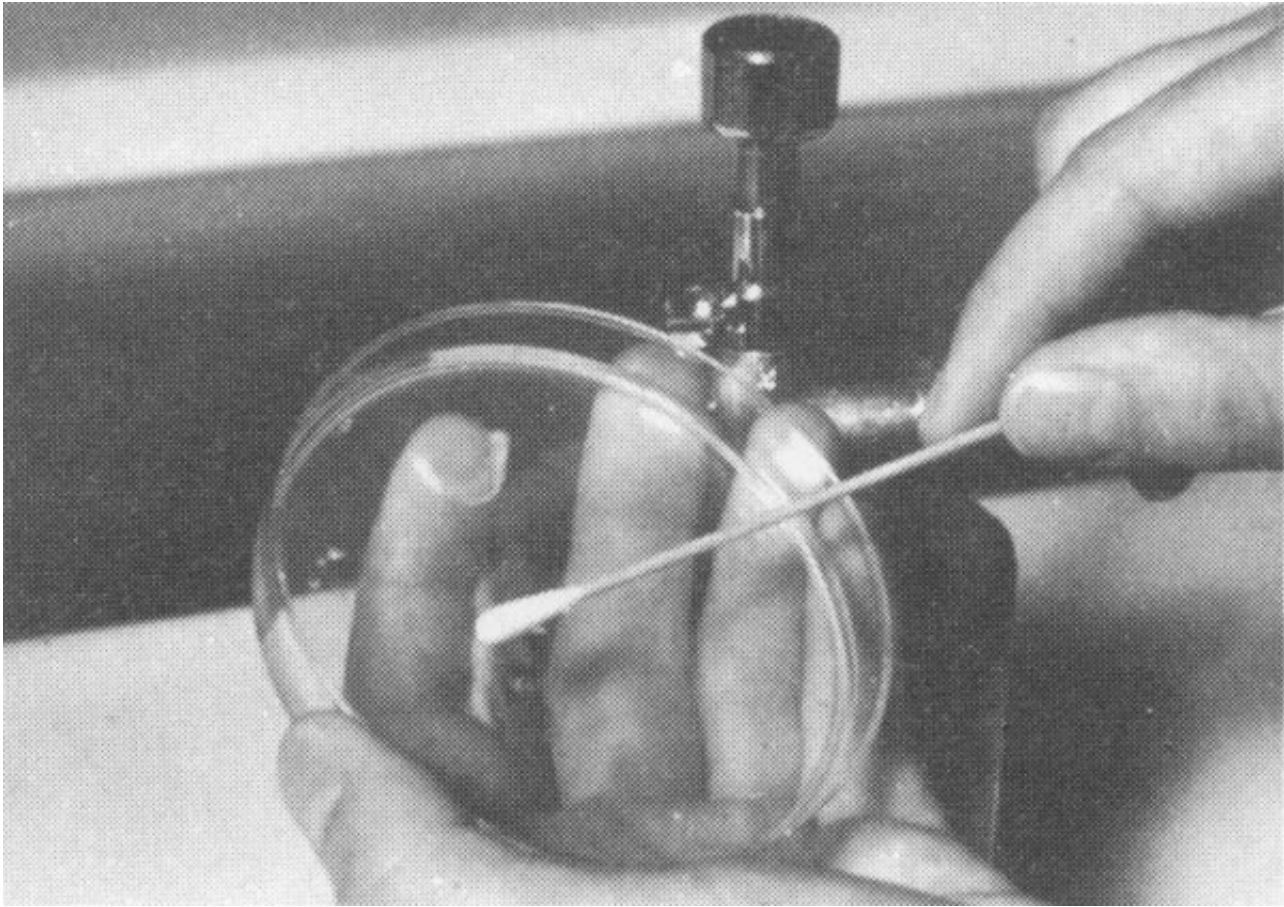
**FIG. 38.**

**Culture medium with various fields after incubation of different samples taken using the technique shown in Fig. 37.**



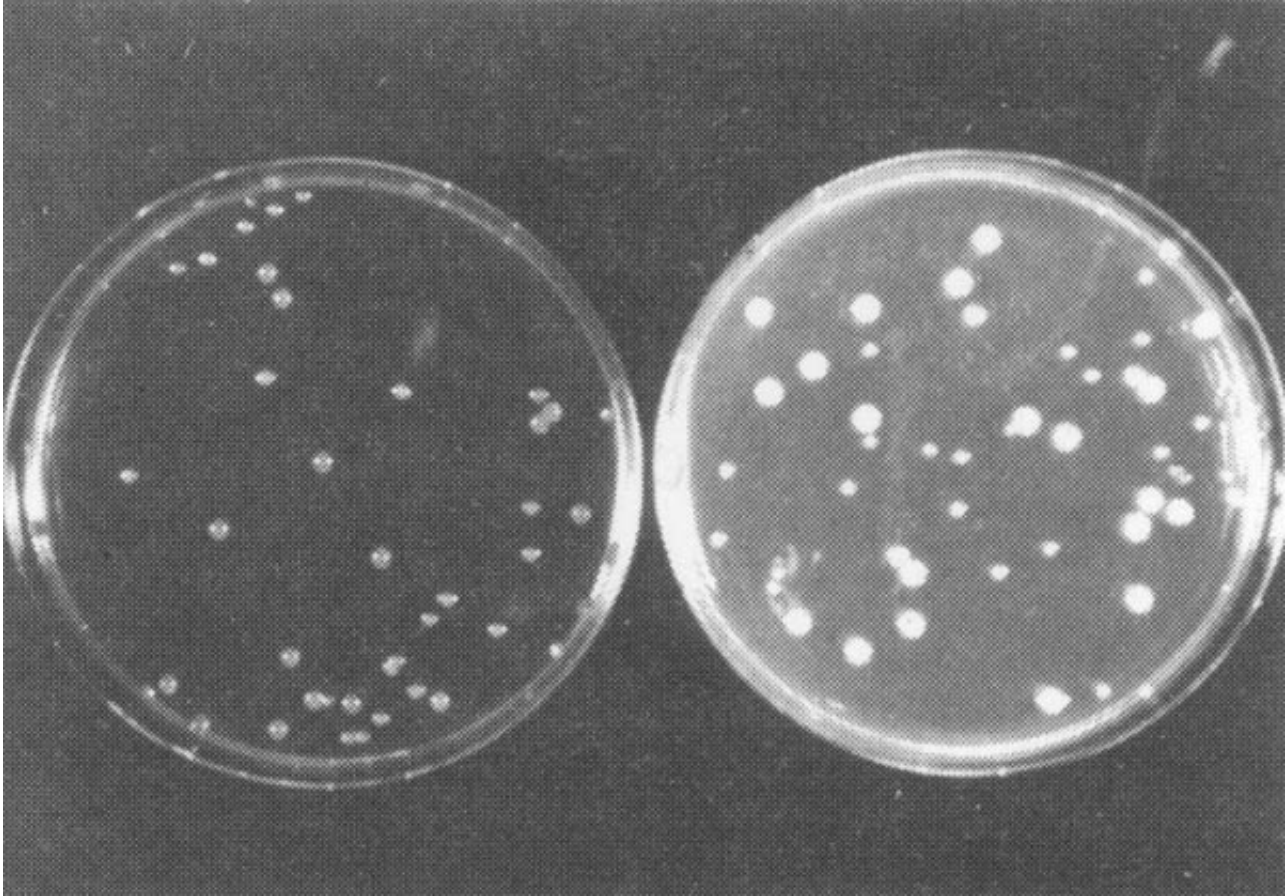
**FIG. 39.**

**Sampling microbial contamination on a defined surface area marked by sterile template with sterile swabs.**



**FIG. 40.**

**Transfer of the sample taken with swab on to the surface of the culture medium.**



**FIG. 41.**

**Bacterial colonies grown from one cell each on the culture medium after the incubation period.**

**FAO TECHNICAL PAPERS****FAO ANIMAL PRODUCTION AND HEALTH PAPERS:**

- 1. Animal breeding: selected articles from World Animal Review, 1977 (C\* E\*F\* S \*)**
- 2. Eradication of hog cholera and African swine fever, 1976 (E \* F \* \* S \*)**
- 3. Insecticides and application equipment for tsetse control, 1977 (E \* F \*)**
- 4. New feed resources, 1977 (E/F/S \*)**



5. Bibliography of the criollo cattle of the Americas, 1977 (**E/S \***)
6. Mediterranean cattle and sheep in crossbreeding, 1977 (**E \* F \***)
7. Environmental impact of tsetse chemical control, 1977 (**E \* F \***)
- 7 Rev. Environmental impact of tsetse chemical control, 1980 (**E \* F \***)
8. Declining breeds of Mediterranean sheep, 1978 (**E \* F \***)
9. Slaughterhouse and slaughterslab design and construction, 1978 (**E \* F \* S \***)
10. Treating straw for animal feeding, 1978 (**C \*, E \*, F \*, S \***)
11. Packaging, storage and distribution of processed milk, 1978 (**E \***)

**12. Ruminant nutrition: selected articles from World Animal Review, 1978 (C \* E \* F \* S \*)**

**13. Buffalo reproduction and artificial insemination, 1979 (E \*\*)**

**14. The African tripanosomiases, 1979 (E \* F \*)**

**15. Establishment of dairy training centres, 1979 (E \*)**

**16. Open yard housing for young cattle, 1981 (E \* F \* S)**

**17. Prolific tropical sheep, 1980 (E \* F \* S \*)**

**18. Feed from animal wastes: state of knowledge, 1980 (E \*)**

**19. East Coast fever and related tick-borne diseases, 1980 (E \* S \*)**

**20/1. Trypanotolerant livestock in West and Central Africa, 1980**

**Vol. 1 - General study (E \* F \*)****20/2. Trypanotolerant livestock in West and Central Africa, 1980****Vol. 2 - Country studies (E \* F \*)****20/3. Le bétail trypanotolérant en Afrique occidentale et centrale****Vol. 3 - Bilan d'une décennie, 1988 (F \*)****21. Guidelines for dairy accounting, 1980 (E \*)****22. Recursos genéticos animales en América Latina, 1981 (S \*)****23. Disease control in semen and embryos, 1982 (E \* F \* S \*)****24. Animal genetic resources - conservation and management, 1981 (E \*)****25. Reproductive efficiency in cattle, 1982 (E \* F \* S \*)**

- 26. Camels and camel milk, 1982 (E \*)**
- 27. Deer farming, 1982 (E \*)**
- 28. Feed from animal wastes: feeding manual, 1982 (E \*)**
- 29. Echinococcosis/hydatidosis surveillance, prevention and control: FAO/UNEP/WHO guidelines, 1982 (E \*)**
- 30. Sheep and goat breeds of India, 1982 (E \*)**
- 31. Hormones in animal production, 1982 (E \*)**
- 32. Crop residues and agro-industrial by-products in animal feeding, 1982 (E/F \*)**
- 33. Haemorrhagic septicaemia, 1982 (E \* F \*)**
- 34. Breeding plans for ruminant livestock in the tropics, 1982 (E \*)**

**F \* S \***)

**35. Off-tastes in raw and reconstituted milk, 1983 (E \* F \* S \*)**

**36. Ticks and tick-borne diseases: selected articles from World Animal Review, 1983 (E \* F \* S \*)**

**37. African animal trypanosomiasis: selected articles from World Animal Review, 1983 (E \* F \*)**

**38. Diagnosis and vaccination for the control of brucellosis in the Near East, 1983 (Ar \* E \*)**

**39. Solar energy in small-scale milk collection and processing, 1983 (E \* F \*)**

**40. Intensive sheep production in Near East, 1983 (E \* Ar \*)**

**41. Integrating crops and livestock in West Africa, 1983 (E \* F \*)**

**42. Animal energy in agriculture in Africa and Asia, 1984 (E/F \*)**

**43. Olive by-products for animal feed, 1985 (Ar \* E \* F \* S \*)**

**44/1. Animal genetic resources conservation by management, data banks and training, 1984 (E \*)**

**44/2. Animal genetic resources: cryogenic storage of germplasm and molecular engineering, 1984 (E \*)**

**45. Maintenance systems for the dairy plant, 1984 (E \*)**

**46. Livestock breeds of China, 1985 (E \*)**

**47. Réfrigération du lait à la ferme et organisation des transports, 1985 (F \*)**

**48. La fromagerie et les variétés de fromages du bassin méditerranéen, 1985 (F \*)**

**49. Manual for the slaughter of small ruminants in developing countries, 1985 (E \*)**

**50. Better utilization of crop residues and by-products in animal feeding: research guidelines - 1. State of knowledge, 1985 (E \*)**

**50/2. Better utilization of crop residues and by-products in animal feeding: research guidelines - 2. A practical manual for research workers, 1986 (E \*)**

**51. Dried salted meats: charque and carne-de-sol, 1985 (E \*)**

**52. Small-scale sausage production, 1985 (E \*)**

**53. Slaughterhouse cleaning and sanitation, 1985 (E \*)**

**54. Small ruminants in the Near East: Vol.I 1986 (E \*)**  
**Selected papers presented at Tunis Expert Consultation**

**55. Small ruminants in the Near East: Vol II 1986 (Ar \* E \*)**

**Selected papers from World Animal Review**

**56. Sheep and goats in Pakistan, 1985 (E \*)**

**57. Awassi sheep, 1985 (E \*)**

**58. Small ruminant production in the developing countries, 1986 (E \*)**

**59/1. Animal genetic resources data banks, 1986 (E \*)**

**1 - Computer systems study for regional data banks**

**59/2. Animal genetic resources data banks, 1986 (E \*)**

**2 - Descriptor lists for cattle, buffalo, pigs, sheep and goats**

**59/3. Animal genetic resources data banks, 1986 (E \*)**

**3 - Descriptor lists for poultry**



**60. Sheep and goats in Turkey, 1986 (E \*)**

**61. The Przewalski horse and restoration to its natural habitat in Mongolia, 1986 (E \*)**

**62. Milk and dairy products: production and processing costs, 1988 (E \* F \* S \*)**

**63. Proceedings of the FAO expert consultation on the substitution of imported concentrate feed in animal production systems in developing countries, 1987 (E \*)**

**64. Poultry management and diseases in the Near East, 1987 (Ar \*)**

**Availability January 1990**

**Ar - Arabic**

**C - Chinese**

**E - English**

**F - French**

**S - Spanish**

**\* Available**

**\*\* Out of print**

**\*\*\* In preparation**

***The FAO Technical Papers are available through the authorized  
FAO Sales Agents or directly from Distribution and Sales  
Section, FAO, Viale delle Terme di Caracalla, 00100 Rome, Italy.***

