

# A manual for the primary animal health care worker

---

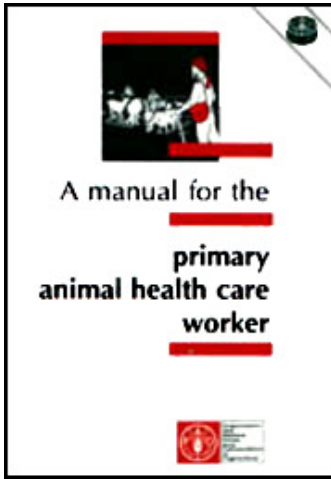

[Table of Contents](#)

---

**Working guide**

**Guidelines for training**

**Guidelines for adaptation**

**FOOD AND AGRICULTURE ORGANIZATION OF THE UNITED**

# **NATIONS**

## **Rome, 1994**

**The designations employed and the presentation of material in this publication do not imply the expression of any opinion whatsoever on the part of the Food and Agriculture Organization of the United Nations concerning the legal status of any country, territory, city or area or of its authorities, or concerning the delimitation of its frontiers or boundaries.**

**M-27**

**ISBN 92-5-103258-0**

**All rights reserved. No part of this publication may be reproduced, stored in a retrieval system, or transmitted in any form or by any means, electronic, mechanical, photocopying or otherwise, without the prior permission of the copyright owner. Applications for such permission, with a statement of the purpose and extent of the reproduction, should be addressed to the Director, Publications Division, Food and Agriculture Organization of the United Nations, Viale delle Terme di Caracalla,**

**00100 Rome, Italy.**

**© FAO 1994**

***This electronic document has been scanned using optical character recognition (OCR) software and careful manual recorection. Even if the quality of digitalisation is high, the FAO declines all responsibility for any discrepancies that may exist between the present document and its original printed version.***

---

## **Table of Contents**

---

### **Preface**

### **Introduction**

## **Part 1: Working guide**

### **Chapter 1: Animals and the community**

#### **Unit 1: Why do we keep animals?**

**Unit 2: Animals and the environment**

**Chapter 2: The animal body**

**Unit 3: Organs and systems of the body**

**Unit 4: Body temperature**

**Unit 5: Appearance of the healthy animal**

**Unit 6: Spread of disease**

**Chapter 3: Cattle, sheep, goats and buffalo**

**Unit 7: Ruminants**

**Unit 8: Bloat (tympany)**

**Unit 9: How to age sheep, goats, cattle and buffalo**

**Unit 10: Restraining cattle and buffalo**

**Unit 11: Foot (hoof) care**

**Unit 12: Shearing and dagging (crutching)**

**Unit 13: Dehorning calves, lambs and kids**

**Unit 14: Castration of ruminants**

**Unit 15: Internal parasites of ruminants**

**Unit 16: External parasites of ruminants**

**Unit 17: Signs of heat (oestrus) in ruminants**

**Unit 18: Pregnancy in ruminants**

**Unit 19: Calving (parturition)**

**Unit 20: Lambing and kidding (parturition)**

**Unit 21: Care of the newborn**

**Unit 22: Milk production and the udder**

**Unit 23: Feed and water for ruminants**

**Unit 24: Grazing management**

**Unit 25: Cattle plague (rinderpest) and foot and mouth disease**

## **Chapter 4: The pig**

**Unit 26: Handling and restraining pigs**

**Unit 27: Teeth clipping in young pigs**

**Unit 28: Internal parasites of pigs**

**Unit 29: Skin infections of pigs**

**Unit 30: Heat (oestrus) in the sow**

**Unit 31: Pregnancy and farrowing (giving birth)**

**Unit 32: Care of the sow and piglet**

[Unit 33: Castrating piglets](#)

[Unit 34: Feeding pigs](#)

[Unit 35: Housing for pigs](#)

[Unit 36: Ear tagging or notching \(identification\)](#)

## [Chapter 5: Horses, donkeys and mules](#)

[Unit 37: How to restrain horses, donkeys and mules](#)

[Unit 38: How to age horses](#)

[Unit 39: Hoof \(foot\) care, shoeing and lameness](#)

[Unit 40: Colic](#)

[Unit 41: Internal parasites of equines](#)

[Unit 42: Skin and coat disorders of equines](#)

[Unit 43: Heat \(oestrus\), mating and pregnancy](#)

[Unit 44: Foaling and caring for the young](#)

[Unit 45: Stabling and grazing](#)

[Unit 46: Feed and water for equines](#)

[Unit 47: Grooming and tackle \(tack\)](#)

[Unit 48: African horse sickness](#)

## **Chapter 6: Chickens and ducks**

**Unit 49: Keeping chickens and ducks**

**Unit 50: Housing for chickens and ducks**

**Unit 51: Feeding chickens and ducks**

**Unit 52: Problems caused by poor feed  
(deficiencies)**

**Unit 53: Incubators and brooders**

**Unit 54: Brooding**

**Unit 55: Internal parasites of chickens and ducks**

**Unit 56: External parasites of chickens and  
ducks**

## **Chapter 7: Camels, llamas and alpacas**

**Unit 57: Camels, llamas and alpaca**

**Unit 58: Ageing camels by the teeth**

**Unit 59: Breeding camels**

**Unit 60: Milk and care of the young camel**

**Unit 61: Feeding and watering of camels**

**Unit 62: Surra of camels (trypanosomiasis)**

**Unit 63: Internal parasites of camels**

**Unit 64: Skin diseases of camels**

**Unit 65: Foot problems in camels**

**Chapter 8: The rabbit**

**Unit 66: Breeding and feeding rabbits**

**Unit 67: Health problems of rabbits**

**Chapter 9: Treating sick animals in general**

**Unit 68: Diarrhoea and constipation**

**Unit 69: Salivation and mouth problems**

**Unit 70: Fever**

**Unit 71: Coughing and breathing problems**

**Unit 72: Eye problems**

**Unit 73: Wounds and bleeding**

**Unit 74: Fractures (broken bones)**

**Unit 75: Lumps under the skin**

**Unit 76: Poisoning**

**Chapter 10: Animal health and the community**



[Unit 77: Rabies \(mad dog disease\)](#)

[Unit 78: Tuberculosis \(TB\)](#)

[Unit 79: Hydatid disease](#)

[Unit 80: Screwworm](#)

[Unit 81: Ringworm](#)

[Unit 82: Disposal of dead animals](#)

[Unit 83: Disposal of dung](#)

[Unit 84: Health of the community](#)

## [Annexes](#)

[Annex 1: Medicines](#)

[Annex 2: Important veterinary tools  
\(instruments\)](#)

[Annex 3: Important techniques](#)

[1. Sterilisation of instruments](#)

[2. Injections](#)

[3. Vaccinations](#)

[4. Drenching](#)

- [5. Boluses \(tablets\)](#)
- [6. Stomach tubing](#)
- [7. Cleaning the udder](#)
- [8. Taking blood samples](#)
- [9. Making blood smears](#)
- [10. Collecting samples for the laboratory](#)
- [11. Collecting faecal samples](#)
- [12. Spraying](#)
- [13. Dipping](#)
- [14. Knots and tethering](#)

[Annex 4: Selection of animals for breeding](#)

[Annex 5: Record keeping](#)

[Annex 6: Weights and measures](#)

[Annex 7: Explanation of terms and index](#)

## [Part 2: Guidelines for trainers](#)

### [1. Creating conditions for learning](#)

**What the trainer must do**  
**The conditions of learning**

**2. Evaluating the trainee's progress**

**Simple and complex tasks**  
**Developing trainee's learning abilities**  
**Evaluating the performance of trainees and the success of the training programme**

**3. The units and learning modules**

**4. Examples of training plans**

**Part 3: Guidelines for adapting this manual**

**1. Introduction**

**2. The need for primary animal health care**

**3. The Primary Animal Health Care Worker (PAHCW) and the community.**

**4. The role of women in PAHC**

**5. Working group**

**6. Adapting the manual**

[7. Adaptation process](#)

[8. Health of the community](#)

[9. Who uses this manual?](#)

[10. Translation](#)



---

## Preface

**Information to help people improve their own well being and that of their environment is always welcome. This manual provides such information which relates to human health and animal health and production. The manual is written for those with the greatest need for healthy and productive animals - rural livestock raisers. These men and women have valuable skills and experience with food animals. The Primary Animal Health Care Worker (PAHCW) manual contains information for men and women at the grass roots level to provide basic animal health and production services in every community. With this manual, some training and minimal supervision, PAHCWs can fill gaps in the animal health care**

**system in developing countries. Such services will provide direct employment in rural areas; the services are simple, appropriate and sustainable.**

**The PAHCW manual is adapted from the Primary Health Worker manual published by the World Health Organization. Adaptation is an important theme throughout the manual. One book cannot contain specific information on animal health and production which applies throughout the world. Feed sources and grasses differ, diseases vary in frequency and importance and names of animal remedies are different. So the manual gives trainers guidance on ways to adapt information to different situations in different localities.**

**This manual is intended for heavy use; it is not a book to remain unopened on a shelf. Space is provided for writing notes and for writing names of locally available animal remedies. PAHCWs are encouraged to write in the manual - this adapts it to local conditions. PAHCWs should carry the manual with them during their visits. If they wear it out, good - they should receive another.**

**The problems, the text and the drawings should be adapted to the conditions of each country and each community in which PAHCWs work. We at FAO and the WHO/FAO Collaborating Centre for Research and Training in Veterinary Public Health fully expect that this manual will be well used, adapted, translated into different languages and found to be useful to improve human conditions at the grass roots level.**

**The contributions made by Dr. Talib M. Ali, veterinarian and training specialist, who compiled the material and authored the text, and Ms. G. Morosetti, biologist and illustrator, who prepared the numerous drawings, are gratefully acknowledged.**

---



---

## Introduction

**This manual is primarily a working guide (Part I) for diagnosing, treating and preventing common food animal diseases, for proper feeding of food animals and for useful husbandry practices for raising healthy and productive food animals. It also contains guidelines (Part II) addressed to primary animal health care worker's trainers and supervisors and Part III contains guidelines for adapting the manual to different conditions in various countries.**

### **Who is the Primary Animal Health Care Worker (PAHCW)?**

**The PAHCW is a man or woman who can read and write and is selected by the local community or with their agreement to deal with animal health and production in the community.**

### **Conditions of Work**

**The PAHCW will be responsible to both the local community authorities and the local government veterinary services. He or she will follow instructions from local government veterinary authorities and work as a team.**

**The PAHCW will be paid for his work, in cash or kind, by the local community; he or she may be full-time or part-time, depending on the requirements.**

### **What Training will the PAHCW Receive?**

**The PAHCW will receive initial training from government veterinary officials in the country. This training will be practical and given near his home. Preferably, the training should be given by local veterinary officials who will be responsible for continued on-the-spot or periodic training. A plan for further training should be worked out.**

### **What will the PAHCW do?**

**The work of the PAHCW will cover both animal health care and community development, as the health of animals and that of the community are very much influenced by any improvement in the environment.**

**The animal health and production work of the PAHCW will be restricted to what he or she has learned. The PAHCW must**



**realize his limitations and know that there is only a restricted number of things he can do. He or she will not be able to solve all the problems encountered, but should be able to deal with the most common and urgent problems.**

**The community development work of the PAHCW should serve to encourage the local authorities and the people to show initiative and take an interest in any activity likely to improve their living conditions. He should always consider what can be done locally with the community's own resources at the least possible cost.**

**The PAHCW's duties will depend on the problems met. These will vary from one country and location to another. It is not possible to draw up a list of problems valid throughout the world.**

**From the problems selected, which make up Part I of the manual, one can outline the functions of the PAHCW:**

- 1. Care for sick animals, protect the health of the people and look after community hygiene.**

- 2. Provide reliable information on animal feeding and husbandry methods to improve the productivity of food animals.**
- 3. Give advice to anyone who consults him, in accordance with the instructions contained in this manual or given by the veterinary services in the country.**
- 4. Refer sick animals to the nearest veterinary centre or contact local veterinary authorities to personally visit the community to examine and treat sick animals. The PAHCW should, therefore, confine his treatment and advice to those cases, conditions and situations described in the manual.**
- 5. With the authorization of the local authorities, visit all farmers and advise the people how to prevent diseases and increase food animal productivity.**
- 6. Make regular reports to the local authorities on the**

**health and productivity of food animals belonging to the community. Get from the local authorities and the people the support needed for his or her work.**

**7. Keep in as close contact as possible with the local veterinary authorities so as to be able to give of his best in his work and to obtain the equipment and supplies required.**

**8. Promote community development activities and play an active part in them.**

**To discharge these functions the PAHCW:**

**a) is available at all times to respond to any emergency calls;**

**b) acts in all circumstances with common sense and devotion to duty, and is aware of his limitations and responsibilities;**

**c) does not leave the community without first informing**

**the local authorities; and**

**d) takes part in the training organized by the veterinary services.**

**The PAHCW should spend some time with other social development workers concerned with improving agricultural practices, food protection, water supply, home economics, etc. He or she must know about services and opportunities for development available in the district and keep his community well informed.**

**It follows then that the PAHCW is the practical expression of a community's determination to be responsible for its own animal health care and production and make up for any deficiencies which might exist in the veterinary service coverage. The PAHCW should improve the community's participation in what will be part of a provincial/national health programme planned and run by the national veterinary service authorities with the active contribution of the people.**



---

## Chapter 1: Animals and the community

---

[Unit 1: Why do we keep animals?](#)

[Unit 2: Animals and the environment](#)

---

### Unit 1: Why do we keep animals?

***We keep animals to provide us with:***

- ***meat***
- ***milk***
- ***eggs***
- ***wool and hair for clothing, ropes and tents***
- ***hides and skin for leather***

- ***bones, hooves and horn for a variety of uses.***

***Some animals are used for transport, ploughing and work.  
We always benefit from the animals we keep.***

## **Learning objectives**

**After studying this unit you should:**

- 1 Know what animals are kept in your community.**
- 2 Know what the animals are used for.**
- 3 Find out if the animals in your community or village are good and healthy.**

**What animals are kept in your community?**

**If you want to be a good Primary Animal Health Care Worker (PAHCW) it is very important for you to know what animals are kept by the people in your community. You must know your community very well and discover who keeps animals and what type of animals they keep. You must work with all of the**

## **community's livestock.**

### **What are the animals used for?**

**What does your community keep its animals for? Are the animals kept for meat or for work? Do they provide you with milk? What other things do you get from the livestock you keep?**

**If you keep animals for meat do you kill the young or the old animal for meat? Does your community keep some animals only for work or for meat, to give milk, or for other reasons? Try to find out as much as you can about the use of animals in your community.**

### **How good are your animals?**

**Are your animals providing you with enough milk or meat? Are your livestock better than those of neighbouring communities or regions? How do your animals differ from those in neighbouring communities?**

**Communities in neighbouring regions can keep different types of**

**animals. For example cows in one region can produce more milk or give better meat than those in another region. You should consider your livestock and compare them to those of your neighbouring communities. Talk to people from other communities or to other Primary Animal Health Care Workers.**

**You may already know of some health problems in your community's livestock. If you talk to others in the community you may find out about other animal health problems. There may be particular problems related to certain breeds or types and not others. Some of the health problems you may discover are:**

- **Animals die suddenly.**
- **Young animals are born sick or dead.**
- **Leg and foot problems.**
- **Skin troubles.**
- **Animals do not increase in weight.**
- **Livestock suffer from worms, ticks or lice.**
- **The udders of milk animals become swollen and blood is found in the milk.**
- **Chickens stop laying eggs or die suddenly.**



**There can be very many health problems. You should talk to the people in your community to discover the various problems they have with the health of their animals, but also try to discover what are the problems in neighbouring communities. You may find that you have the same problems or you will gain knowledge which will help you prevent a health problem reaching your community's livestock.**

**You must keep good contacts with your nearest veterinarian and livestock specialist. Remember that these people are there to help you.**

**Keep an animal health record for your community**

**It will help you to succeed as a Primary Animal Health Care Worker if you keep a record of the health and other problems of your community's livestock.**

**Make a record of who keeps the various animals. Discover and make note of the problems that they have. Talk to the owner of the animals and discover if the problems are related to a**

**particular time of the year or season, changes in food or water supply, movement of livestock or the introduction of new animals to the herd (see Annex 5).**

**Keep an animal health record for your community**

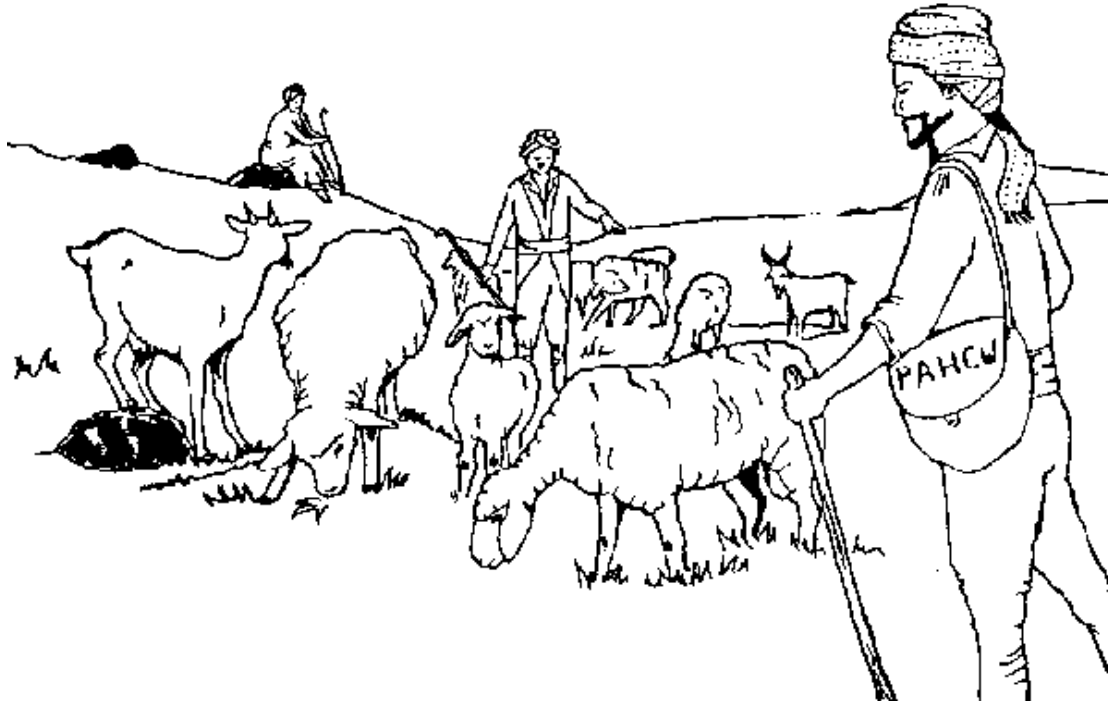

## Unit 2: Animals and the environment

***The environment is what you find around you. The plants, water, soil and climate are all part of your environment.***

***Man keeps animals which are suited to his needs and his environment.***

***There is a limit to the number of animals which we can keep in any area.***

***If we ignore these facts we can have management and health problems in our livestock and damage to the local environment.***

## **Learning objectives**

**After studying this unit you should know:**

- 1 The problems which can result from keeping too many animals.**
- 2 If the animals you keep are suited to your environment and your needs.**
- 3 The different breeds (types) of animals kept in your community.**
- 4 Any areas of the community's land which have been damaged by animals.**

## **Different breeds (types) of animal**

**Throughout the world man keeps animals which are suited to the local environment. Feed, water and climate are the main factors which determine what animals are in any one region. As a result of this we find a large variety of animal breeds throughout the world.**

- **In England sheep have thick woolly fleeces to protect them against cold winters. In Somalia, where the climate is very hot, the sheep have light, hairy coats**

### **Sheep (English - Somali)**

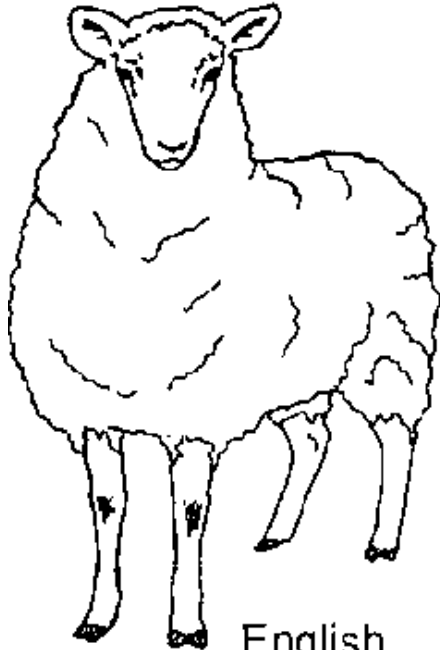

English

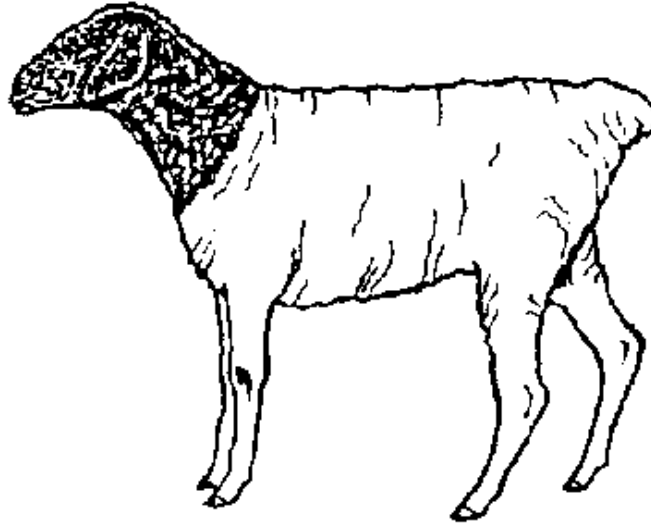

Somali

- **Friesian cows produce a lot of milk on the good grasslands in countries with cool weather conditions. In India the Sahiwal cattle are good milk producers in the hot tropics.**

### **Cows (Friesan - Sahiwal)**

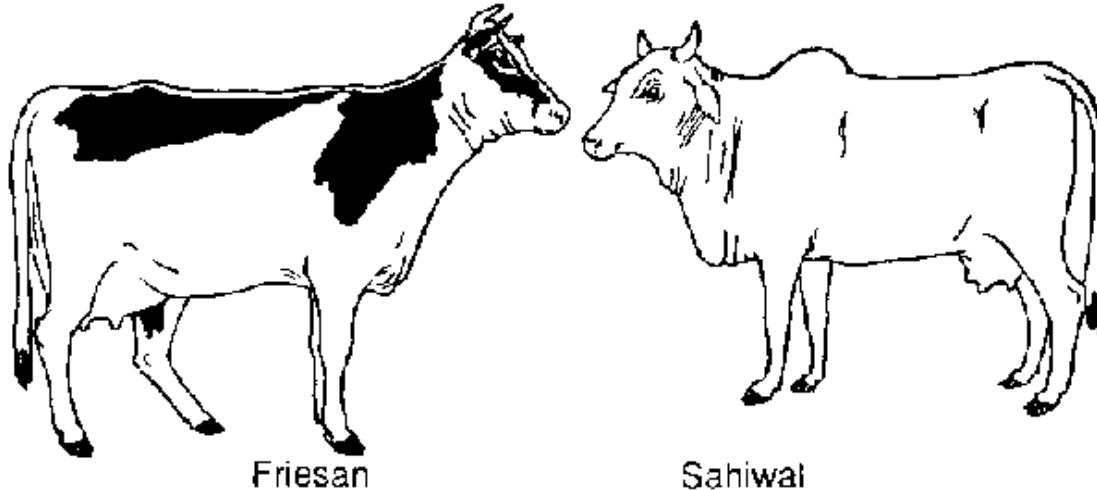

- In China pigs are fed on food which is mainly roughage and so developed a pot-belly to use this type of food. In Europe pigs are fed a lot of grain and have leaner bodies.

### [Chinese pot belly pig - European pig](#)

**Remember that the livestock in your community developed over a long time. They are accustomed to your environment.**

**Sometimes people want to introduce new breeds to an area. This must be carefully considered and advice taken from knowledgeable persons as the new breeds may not be suited to the new environment.**

**The number of animals kept in the community**

**We should not keep animals which are old or barren as they will eat the feed that could be better used for young animals.**

**You should consider the number of animals kept in your community. Is enough feed and water available for them all year? Discuss with your community elders and leaders any problems you may discover in the numbers of animals and the available feed and water. Controlling and planning livestock numbers and the availability of good feed and water is basic to primary animal health care.**

**Problems of overstocking (too many animals)**

**If we do not keep the numbers of livestock in relation to available feed and water then:**



- **Animals lose weight, become sick and disease spreads.**
- **Animals do not breed well and death of young occurs.**
- **Overgrazing and loss of pasture, bushes and trees occur.**
- **Loss of vegetation will result in erosion of soil and loss of good land.**

***Talk to the elders in your community and discover what changes there have been in the environment and what may have caused them. Can the situation be improved?***

---



---

## **Chapter 2: The animal body**

---

[Unit 3: Organs and systems of the body](#)

[Unit 4: Body temperature](#)

[Unit 5: Appearance of the healthy animal](#)

[Unit 6: Spread of disease](#)

---

## Unit 3: Organs and systems of the body

***The body is made up of many, many millions of cells which you can not see unless you use a microscope. Special cells come together to make an organ.***

***An organ is a complex structure within the body. It has a special job or jobs to do.***

***A body system consists of a number of organs which work together to carry out a special job.***

***The animal body is made of 9 systems:***

***Musculo-skeletal system***

***Digestive system***

***Circulatory system***  
***Respiratory system***  
***Urinary system***  
***Nervous system***  
***Sensory system***  
***Reproductive system***  
***Lympho-reticular system***

## **Learning objectives**

**After studying this unit you should know:**

- 1 The various organs of the body.**
- 2 The position of the main organs within the body.**
- 3 The structure of the body systems.**
- 4 How the systems work.**

## **The organs of the body**

**An organ is a complex structure with a special job or a number of jobs to do. For example:**

- **The eye is the organ of sight.**
- **The kidneys are organs which get rid of water and poisonous materials from the body as urine.**
- **The liver has many jobs and is involved in more than one system.**

***Various organs are grouped together to form a body system which carries out a special job.***

<b>System of the Body</b>	<b>Organs in the Body</b>	<b>Job or function</b>
<b>Musculo-skeletal</b>	<b>muscle (meat) bones</b>	<b>Support and move the body</b>
<b>Digestive</b>	<b>stomach, liver, intestine, pancreas</b>	<b>Digest and absorb feed</b>
<b>Circulatory</b>	<b>heart, blood vessels</b>	<b>The blood carries substances around the body</b>
<b>Respiratory</b>	<b>muzzle, windpipe, lungs</b>	<b>Breathing</b>
<b>Urinary</b>	<b>kidneys, bladder</b>	<b>Get rid of poisons and</b>

		<b>waste (urine)</b>
<b>Nervous</b>	<b>brain, nerves spinal cord</b>	<b>Pass messages around the body, control the body</b>
<b>Sensory</b>	<b>eyes, ears, nose skin</b>	<b>Sense and detect things outside the body</b>
<b>Reproductive</b>	<b>testes, penis ovaries, uterus, vagina, vulva, udder</b>	<b>To produce and feed young</b>
<b>Lympho-reticular</b>	<b>lymph nodes, spleen</b>	<b>Protect against infectious diseases, produce blood</b>

## **The musculo-skeletal system**

**This system consists of the bones and the muscles (meat).The bones form the skeleton which is the framework within the body. It carries weight and supports the body.**

**Bones are connected together so they can move. The places**

**where this happens are called joints. The bones are held together at the joints by elastic strands called ligaments. Between the bones is a softer material called cartilage (gristle) which cushions the bones at the joints when the body moves. Bones are very hard and contain minerals. Each bone has a name such as the scapula (shoulder blade) and skull (head). There are about 200 bones in the body.**

**Muscles are joined at both ends to the bones. The muscles are the meat of the body and when they contract (shorten) or relax (lengthen) they make the bones move.**

**If you bend your arm you can see and feel the muscles in your arm working.**

## **The digestive system**

**The digestive system consists of the teeth, mouth, gullet (oesophagus), stomach, liver, intestine, pancreas, and rectum.**

**Digestion begins in the mouth where food is broken down into small pieces by the teeth and mixed with saliva before being**

**swallowed.**

**In the stomach feed is mixed with the juices to form a soft paste. This then passes into the intestine where bile from the liver and juices from the pancreas are added. The action of these juices is to break down the feed and allow the nourishment it contains to be absorbed by the blood in the walls of the intestine. Waste matter collects in the rectum and passes out of the body through the anus (or cloaca in birds).**

### **[The digestive system](#)**

#### **The circulatory system and blood**

**The organs of the circulatory system are the heart and the blood vessels (tubes). The heart is found in the chest cavity. It is a muscular pump which sends blood around the body.**

**The blood vessels which carry blood away from the heart are called arteries. Blood returns to the heart in veins. Joining the arteries and veins is a fine network of small tubes called**

**capillaries. The capillaries pass through every part of the body.**

**When the heart beats its muscles contract and sends blood out through the arteries. When the heart relaxes blood flows into it from the veins.**

**Every time the heart beats it sends a pulse along the arteries. You can feel it at certain points on the body. By feeling the pulse we can count the rate at which the heart beats (see Unit 5). You can feel your pulse on your wrist.**

## **The respiratory system**

**Respiration (breathing) consists of inspiration (breathing in) and expiration (breathing out).**

**There are two lungs which are found in the chest protected by the bony cage of the ribs. The windpipe carries air from the nostrils to the lungs which are spongy because of air spaces in them. As the animal breathes, air moves in and out of the lungs. Inside the lungs oxygen needed by the body passes into the blood in the walls of the lungs and water and carbon dioxide pass**



**out of the blood into the air which is then breathed out.**

### **The respiratory system**

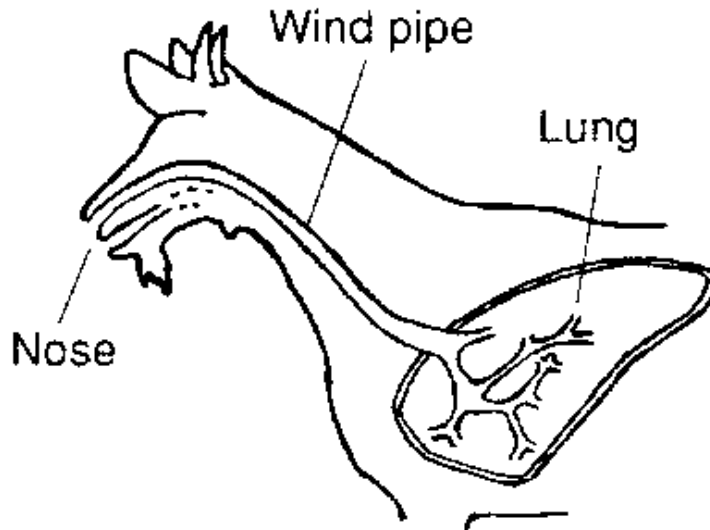

### **The urinary system**

**The main organs are the two kidneys, which lie against the backbone, and the bladder.**

**Waste materials and water are taken out of the blood in the kidneys. This forms urine. Urine collects in the bladder then passes out of the body.**

## **Nervous system and sensory system**

**The bones of the skull and backbone protect the soft brain and spinal cord. Fibres called nerves pass from the brain and spinal cord to all parts of the**

**Messages pass from the various parts of the body along the nerves to the brain. The brain sends a message back telling the different parts of the body what to do.**

**The brain controls the body.**

## **Nervous system**

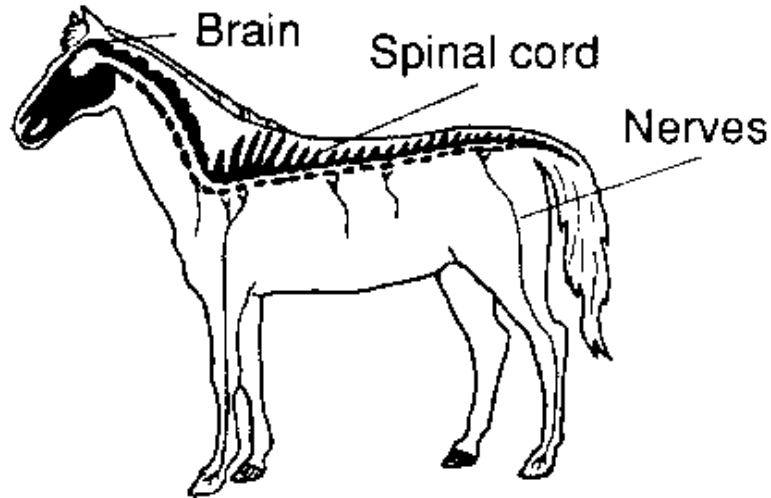

**The brain also controls the senses, the sense organs are:**

- **the eyes for sight**
- **the ears for hearing**
- **the nose for smell**
- **the tongue for taste**
- **the skin for touch**

**Reproductive system (breeding)**

**The male reproductive organs, the testicles, lie in the scrotum behind the penis. The testicles produce sperm which are contained in the fluid semen. A tube passes from each testicle and joins to form a tube which runs down the centre of the penis.**

**In the bird the testicles are inside the body.**

### **Reproductive and urinary organs of the male**

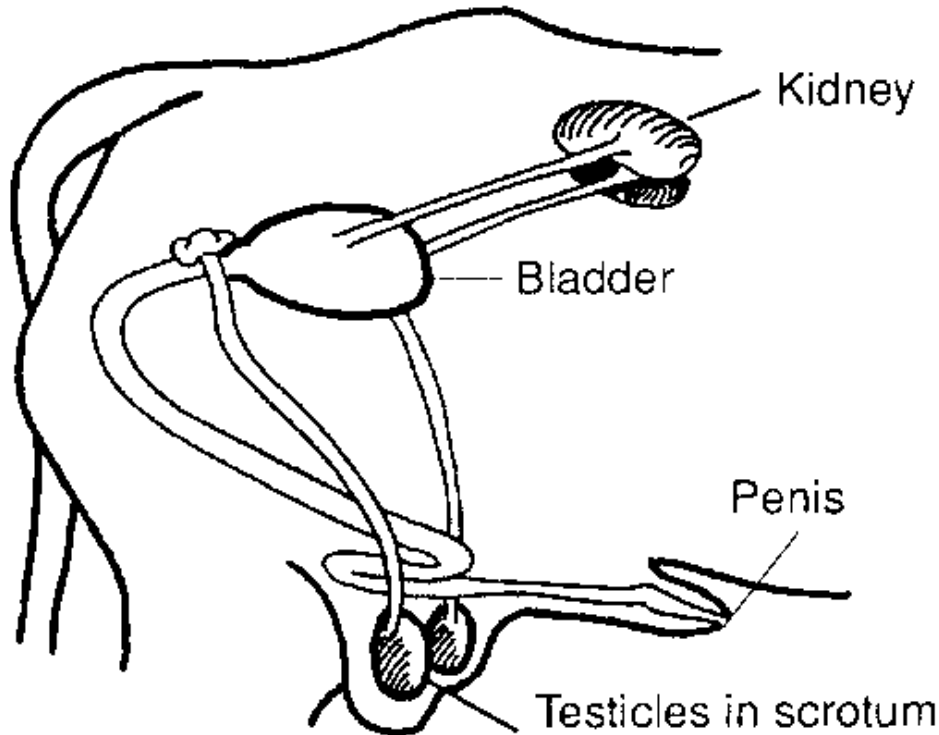

**The female reproductive organ consist of two ovaries, one in each side of the lower abdomen. The ovaries produce eggs which pass into the uterus (or womb). Below the uterus is the vagina which opens to the outside surrounded by the vulva. After birth**

**the young are fed on milk produced by the udder.**

## **Female reproductive and urinary system**

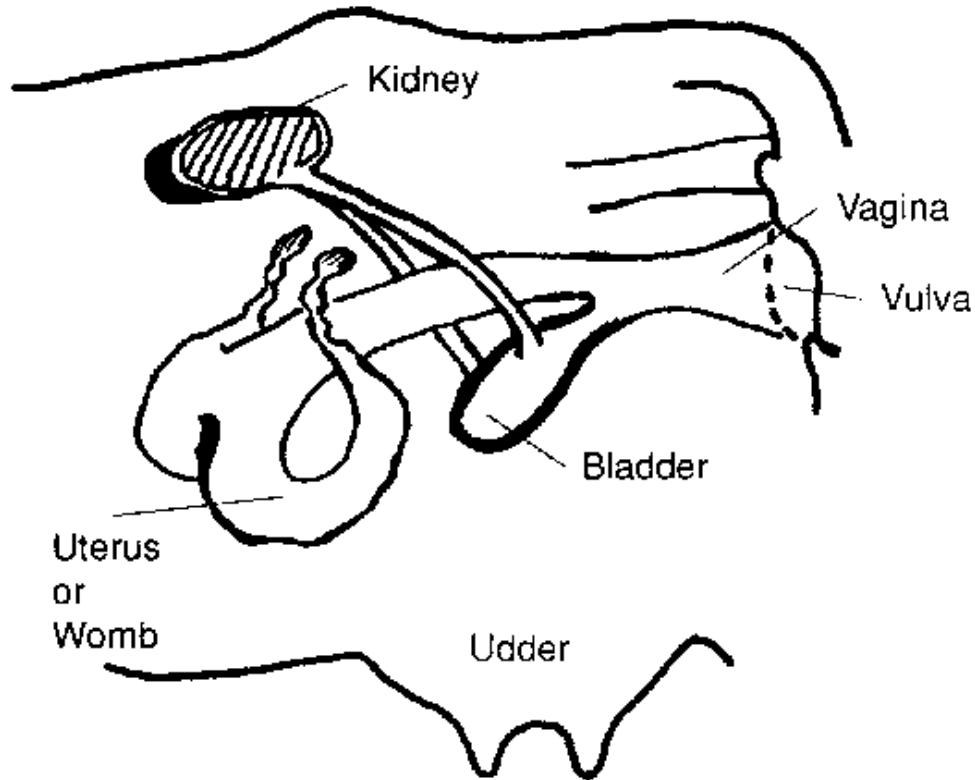

**During mating (mounting) sperm passes from the male into the uterus and joins with the eggs there. When the sperm joins the**

**egg it forms the embryo which develops into the young animal inside the uterus.**

**Reproduction is controlled by hormones (chemical messengers) which are carried in the blood to the different organs.**

**These hormones control:**

- **Puberty of the animal**
- **Production of eggs**
- **Birth**
- **Production of semen**
- **Development of the embryo**
- **Milk production**

## **Lympho-reticular system**

**Lymph is a colourless fluid which passes out of the blood into a network of fine tubes called the lymphatic system. It passes through the lymph nodes, where germs are filtered out and killed, before it is returned to the veins. The lymph nodes and spleen also produce special blood cells which protect the body against**



**disease. Sometimes when an animal is infected the lymph nodes become swollen and can be felt beneath the skin (see Unit 75).**

## **Unit 4: Body temperature**

*The body must be kept at a constant temperature, within a small range, in order for all of the systems to work properly. This is the normal body temperature.*

*A change in the temperature of the body is a sign of ill health.*

### **Learning objectives**

**After studying this unit you should understand what is meant by:**

- 1 The normal body temperature.**
- 2 High body temperature.**
- 3 Low body temperature.**
- 4 How to take the body temperature.**
- 5 What is the normal body temperature of different animals.**

## **The normal body temperature**

**The body can only work properly at a certain temperature. The animal body maintains itself at a constant temperature, within a small range, in order for the systems to work properly. This normal body temperature is different in different types of animals.**

**There are a number of ways by which animals control the temperature of the body:**

- **Hair, wool, walking, running, shivering and the burning of energy in feed keep the body warm.**
- **Sweating, panting, wallowing in mud, and lying in the shade cool the body.**

## **Measuring body temperature**

**We use a thermometer to measure the temperature of the body. The unit of measurement is degrees centigrade (°C). The normal temperature of your body is 37°C. We measure the body temperature of animals by placing a thermometer in the anus.**

## ***The thermometer***

- **Look at your thermometer. Notice the silver line of the mercury inside it and the scale with numbers marked along it.**
- **Before you use it you must make sure that the mercury level is below 35°C. If it is not, shake the thermometer to make the level go down.**
- **Every time you use the thermometer clean it with cold water and soap or disinfect it afterwards.**

***Do not wash the thermometer in hot water as this will burst it. Do not leave your thermometer in the sun as this may burst it. Carry the thermometer in a case in your pocket or bag. Do not use your veterinary thermometer for people.***

## **Thermometer**

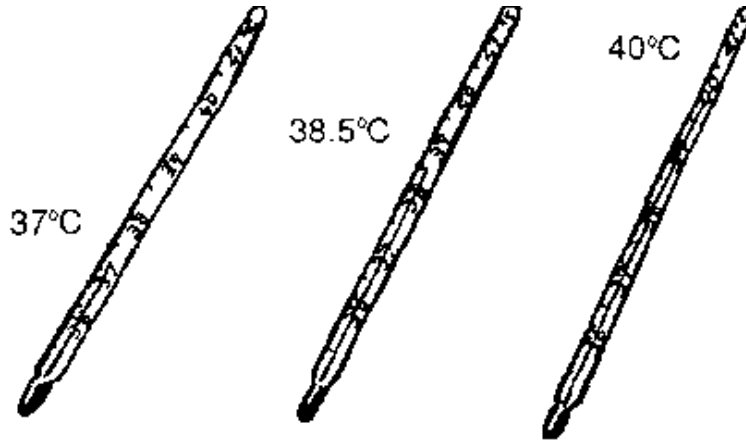

## How to take the body temperature of animals

- Control the animal.
- Move the tail to the side.
- Put the thermometer gently into the anus, as far as possible.
- Hold the thermometer at an angle so that it touches the wall of the rectum. Keep a firm grip on the thermometer,

**if the animal defecates or coughs the thermometer could come out or go into the rectum.**

- **Hold the thermometer in place for half a minute. If you do not have a watch count slowly up to 30 (one, two, three, ..... thirty).**
- **Remove the thermometer and wipe it if necessary and read it. Do not touch the bulb as this could change the reading.**

**How to take the body temperature of animals**



## Normal body temperatures

Animal	Normal Temperature °C	Normal Animal	Temperature °C
<b>Cattle</b>	38.5	<b>Calf</b>	39.5
<b>Buffalo</b>	38.2	<b>Goat</b>	39.5
<b>Sheep</b>	39.0	<b>Camel*</b>	34.5-41.0
<b>Llama, alpaca</b>	38.0	<b>Horse</b>	38.0
<b>Donkey</b>	38.0	<b>Pig</b>	39.0

<b>Donkey</b>	38.2	<b>Pig</b>	39.0
<b>Chicken</b>	42.0	<b>Piglet</b>	39.8

***Body temperatures may be 1°C above or below these temperatures.***

***\* The camel's body temperature will vary with the time of day and water availability. When a camel is watered daily its body temperature rises from 36.5°C in the morning to 39.5°C at noon, if the animal has no water, the temperature range is 34.5°C to 41°C.***

***If you suspect that the animal has a high temperature use your thermometer to check it. Remember that a high temperature is one sign of ill health. When an animal has a high temperature it has a fever.***

## **Unit 5: Appearance of the healthy animal**

***You should be able to distinguish between the sick and the healthy animal. Identifying the signs of ill health in livestock will***

***mean that you can:***

- ***Give first aid and treat ill animals quickly***
- ***Prevent the spread of disease to other animals***
- ***Recognise any problems in animals offered for sale***
- ***Recognise any signs of health problems in animals to be used for breeding***

**Learning objectives**

**After studying this unit you should know:**

- 1 The characteristics of the healthy animal.**
- 2 Recognise the signs of ill health.**

**Appearance of the animal**

**The healthy animal is alert and aware of its surroundings. It is active and holds its head up watching what is happening around it. It should stand on all of its feet. The separation of an animal from the others in its group is often a sign of a health problem.**



**An animal which is not interested in its surroundings and does not want to move has health problems.**

## **Movement (gait)**

**The healthy animal will walk easily and steadily with all of its feet taking its weight. Steps should be regular. Irregular movement results from pain in the feet or limbs.**

**Horses normally stand during the day. If you go near an animal that is lying down it should stand up quickly otherwise it has health problems.**

## **Eyes**

**The eyes should be bright and alert with no discharge at the corners.**

## **Ears**

**Most animals have erect ears which move in the direction of any sound. Ear movements will also be quick to get rid of flies, he**

**body temperature of the pig can be checked by touching the ear when an unusually high temperature will be noticed.**

## **Nose and Muzzle**

**The nose should be clean with no discharge. In cattle and buffalo the muzzle should be moist not dry. In sheep and goats the nose should be cool and dry. Healthy animals frequently lick their noses with their tongues.**

## **Nose and Muzzle**

# Muzzle

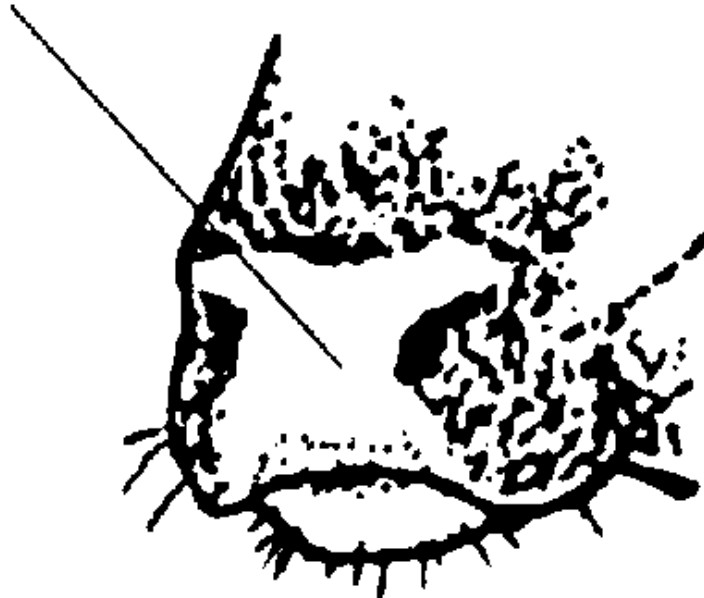

## Mouth

**There should be no saliva dripping from the mouth. If chewing is slow or incomplete there must be a problem with the teeth.**

## **The coat**

**In short-haired animals, e.g. goat and cattle, the hair or coat of the healthy animal will be smooth and shiny. Healthy cattle, buffalo and their calves lick their coat and the lick marks will show. Horses should not sweat when resting.**

## **The coat**

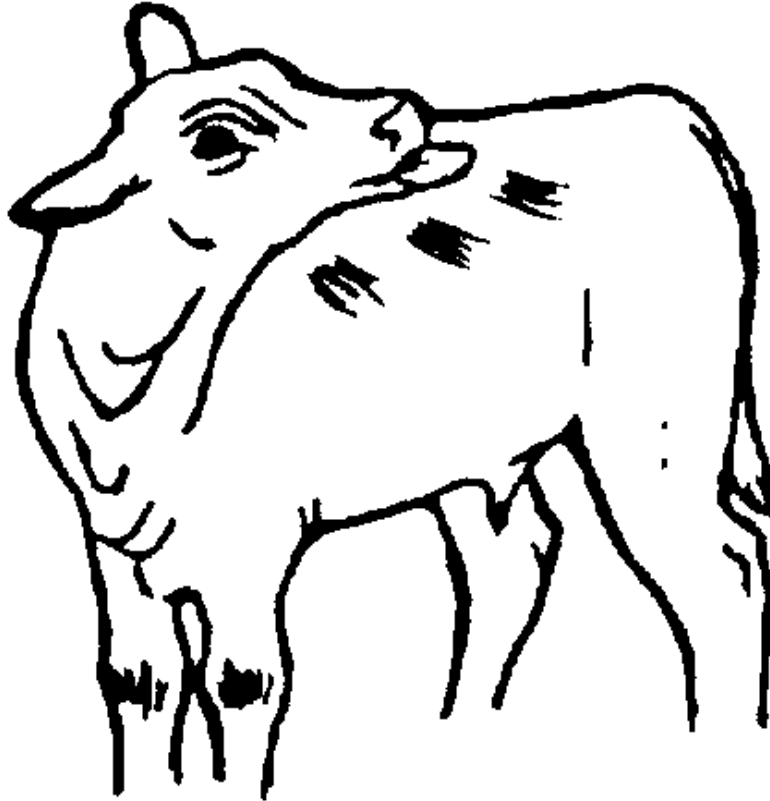

**In poultry the feathers should be smooth and glossy and not ruffled. In pigs a curly tail is a sign of good health while a scaly**

**skin points to health problems.**

## **Behaviour**

**If a horse, cow or buffalo keeps looking at its flanks or kicks at its belly it has a pain in the stomach.**

## **Breathing**

**Breathing should be smooth and regular at rest. Remember that movement and hot weather will increase the rate of breathing. If the animal is resting in the shade it should be difficult to notice the chest moving as it breathes.**

## **Pulse**

**Taking the pulse (see unit 3) is important when examining an animal. In man the pulse can be easily taken but in animals it is more difficult and requires practice.**

- **In sheep and goats you can feel the pulse on the inside of the top of the back leg. The rate of the pulse is 70 -**

## **130 per minute in the adult.**

- **The pulse of cattle is taken at a point on the underside of the base of the tail, the normal rate is 40 - 80 per minute in the adult. In buffalo the pulse rate is 40 - 60 per minute.**
- **The pulse of the horse is taken on the inside of the cheek. The normal rate is 35 - 40 per minute.**
- **The pulse of the camel is taken at a point on the underside of the root of the tail. The normal rate is 35 - 45 beats per minute.**

**Remember that the pulse will be higher in the young animal. To take the pulse you should feel for it with the first two fingers of the hand.**

**In the llama, alpaca and the pig there is no point at which the pulse can be taken. In these animals the beat of the heart itself must be felt for.**

## **Droppings or dung**

**The droppings of the healthy animal will be firm. Very soft droppings (diarrhoea) is a sign of ill health. If the animal has difficulty in defecating (constipation) this is also a bad health sign.**

## **Urine**

**The urine should be clear and the animal show no signs of pain or difficulty in urinating. Horses, mules and donkeys can have thick yellow urine which is normal.**

## **Appetite and rumination**

**The animal should eat and drink normally. Failure to eat is an obvious sign of ill health. If feed is available the healthy animal will have a full belly. Pigs will naturally rush at their feed, if they do not something is wrong. Sheep, goats, cattle, buffalo and camels chew the cud (ruminate) for 6 to 8 hours each day. It is a sign of ill health when these animals stop ruminating.**



## **Milk**

**In the milking animal a sudden change in the amount of milk produced can mean a health problem. Any sign of blood or other matter in the milk points to infection in the udder. There should be no swelling of the udder and no sign of pain when it is touched. There should be no injury to the teat.**

### **Body temperature**

**If you suspect that an animal is sick you should take its temperature (see Unit 4). Taking the temperature may show a higher than normal body temperature which is sign of an infection.**

**A good PAHCW learns to:**

- Carefully watch the normal animal at all times and learn how it behaves.**
- You will then recognise when something is not right.**

- **Question the person looking after the animals to discover if he or she has noticed anything different about them.**
- **Remember you must first watch the animals from a distance, talk to the person who looks after them, and then check the animals. You will then be able to decide what to do next.**

## **Unit 6: Spread of disease**

***Disease occurs when something goes wrong with the body or part of the, body.***

***Diseases can be caused by germs, bad feed, chemicals or injuries.***

***Diseases caused by germs are called infectious diseases.***

***An infectious disease can spread from one animal to another.***

### **Learning objectives**

**After studying this unit you should know:**

#### **1 How animals become ill.**

- 2 What is meant by the spread of disease.**
- 3 What is an infectious disease.**
- 4 What is a non-infectious disease.**
- 5 How to prevent the spread of disease.**

## **The main causes of disease**

**Disease can be classified as acute or chronic. An acute disease starts quickly and lasts for a short period when the animal either recovers or dies. A chronic disease lasts for a long time and weakens the animal. Diseases are said to be infectious (will spread from one animal to another) or noninfectious (will not spread from one animal to another).**

**Non-infectious diseases can be caused by poor feed and the lack of minerals, salts and vitamins that the body needs. Non-infectious disease can also be caused by poisoning with chemicals or plants, by cuts, burns and broken bones. Some diseases pass from the parent to the young (hereditary).**

**Many non-infectious diseases are chronic but they can be acute.**

**They can cause large losses of meat, milk and wool. Working (draught) animals do not work well and the rate of reproduction can be low with the young being born dead or dying before they are weaned. Chronic diseases are often thought to be "normal" but when the cause is known and eliminated production can be greatly increased.**

**Infectious diseases are caused when the body is attacked by tiny living germs.**

**The spread of disease**

**Infectious diseases can be spread by:**

- **Direct contact between animals.**
- **Germs in feed and water.**
- **By faeces and urine from sick animals.**
- **By flies, ticks, lice and fleas.**
- **By dirty housing or shelters.**
- **Young and old animals become infected more easily.**

## Preventing infectious diseases

- **Animals, like humans, must be clean in order to be healthy. The animal must be provided with clean feed, water, bedding and shelter.**
- **Sick animals should be kept separate from the others.**
- **Some diseases can be cured by drugs.**
- **Vaccination can protect animals against some diseases.**
- **Dead animals and waste should be disposed of.**

### ***Remember:***

- ***The spread of disease can be avoided by good livestock management. Keeping animals together increases the chance of disease spreading by contact. New livestock should be kept separate from the others for two weeks so they can be checked for signs of disease.***
- ***Avoid mixing herds. Try to keep herds separate at watering and feeding points.***

- ***You should separate and isolate any animal which shows signs of disease.***

## **Preventing non-infectious diseases**

**The chronic non-infectious disease may not be recognised as a disease. The affected animals may not die but will not produce as much milk, meat or wool, or work as well as could be expected.**

**If we continually look for ways of improving feed, water, mineral and vitamin supplies we will find the way to control the non-infectious diseases. This will lead to greater production of wool, meat and milk, draught animals will be stronger and more young will be produced. Poultry will produce more eggs and get fatter.**



## Chapter 3: Cattle, sheep, goats and buffalo

---

[Unit 7: Ruminants](#)

[Unit 8: Bloat \(tympany\)](#)

[Unit 9: How to age sheep, goats, cattle and buffalo](#)

[Unit 10: Restraining cattle and buffalo](#)

[Unit 11: Foot \(hoof\) care](#)

[Unit 12: Shearing and dagging \(crutching\)](#)

[Unit 13: Dehorning calves, lambs and kids](#)

[Unit 14: Castration of ruminants](#)

[Unit 15: Internal parasites of ruminants](#)

[Unit 16: External parasites of ruminants](#)

[Unit 17: Signs of heat \(oestrus\) in ruminants](#)

[Unit 18: Pregnancy in ruminants](#)

[Unit 19: Calving \(parturition\)](#)

[Unit 20: Lambing and kidding \(parturition\)](#)

[Unit 21: Care of the newborn](#)

[Unit 22: Milk production and the udder](#)

[Unit 23: Feed and water for ruminants](#)

[Unit 24: Grazing management](#)

## [Unit 25: Cattle plague \(rinderpest\) and foot and mouth disease](#)

---

### **Unit 7: Ruminants**

#### [Animals carnivore, omnivore and herbivores](#)

#### **Learning objective**

**After studying this unit you should know:**

- 1 What are the animal groups.**
- 2 What is the rumen.**
- 3 What makes the ruminant different.**
- 4 Why animals chew the cud (*ruminates*).**

#### **Who eats what**

**Animals are divided into three groups:**

• **Carnivores which eat meat.**

**e.g. dog, lion**



- **Omnivores which eat meat and plants, e.g. pig**
- **Herbivores which eat plants e.g. cow, horse**

**The digestive system of omnivores and carnivores is as described in Unit 3. In herbivores the digestive system is very large because they eat large amounts of grass.**

- **The horse, donkey and mule are herbivores but do not chew the cud. They are non-ruminants.**
- **Cattle, goats, sheep and buffalo chew the cud. They are ruminants.**

**The rumen (stomach)**

**The stomach of a ruminant has four chambers. The first chamber is very large and is called the rumen. The second chamber is the reticulum (honeycomb). The third is the omasum (book) and the fourth is the abomasum (the true stomach). The ruminant chews grass and swallows and it goes into the rumen.**

## **The rumen (stomach)**

**When the ruminant has finished eating, the food is brought back up and rechewed. This is called chewing the cud or rumination. If the animal stops ruminating this is a sign of ill health.**

**Ruminants make a lot of gas in their stomachs and belch once every minute, (unlike people they belch silently). If the belching stops the stomach swells with gas. We call this bloat or tympany (Unit 8).**

### **Rumen movement**

**The rumen moves regularly and contracts about once every minute. By putting your fist on the left flank (in the hollow behind the ribs) you will be able to detect the contractions. Regular contractions are a sign of good health.**

### **Rumen movement**

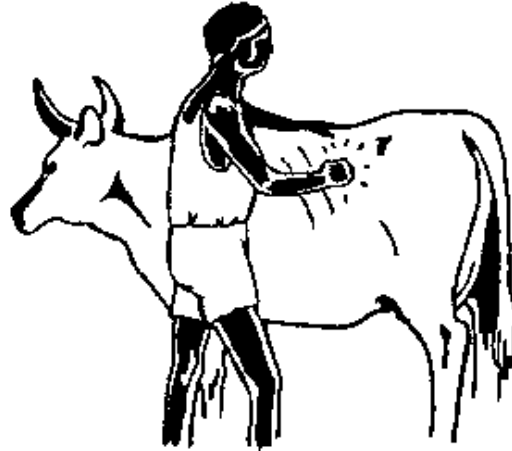

## **Nails and wires in the rumen**

**Because ruminants eat quickly they can swallow objects like nails and wires with their feed. These objects can damage the rumen and can pass through the wall of the rumen into the heart and kill the animal.**

***You should tell your community to keep nails, wires and similar objects away from animal feed and pasture.***

## **Unit 8: Bloat (tympany)**

***Bloat occurs when too much gas is produced in the rumen. The left flank becomes distended and breathing becomes difficult.***

***This may happen suddenly, especially when the animal is grazing on wet pasture in the morning.***

***It may cause sudden death.***

## **Learning objectives**

**After studying this unit you should know:**

- 1 What is bloat (tympany).**
- 2 What causes bloat in the ruminant.**
- 3 How to prevent bloat.**
- 4 How to treat the animal with bloat.**

**What is bloat (tympany)?**

**In Unit 7 you learned that the stomach of ruminant animals produces a lot of gas. The animals continually belch, once each minute, to get rid of the gas. Occasionally belching stops and gas**

**builds up in the rumen to cause bloat.**

**As the gas builds up the left flank balloons out. The pain from this causes the animal to try to kick its belly or it stands with its back legs wide apart. It has difficulty in breathing.**

### What is bloat

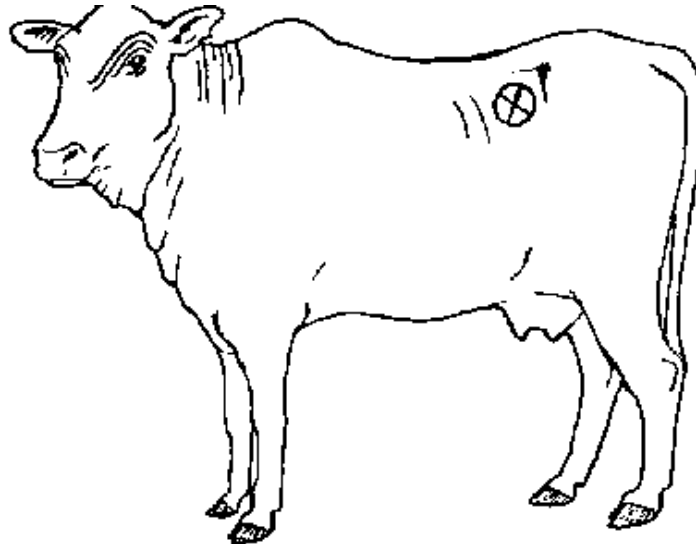

**The animal may be in distress for several hours but in bad cases**

**of bloat the animal will be found lying on its side and death can occur in a few hours.**

## **Causes of bloat**

**Bloat can occur when the animal grazes on lush young pasture, particularly if the pasture is wet. Some plants, e.g. clover, lucerne and alfalfa are especially dangerous in causing bloat but any fast growing plants can cause it.**

**Sometimes ruminants kept by the household and fed only feed such as dry bread can develop bloat.**

## **Preventing bloat**

- **Avoid moving animals to wet pasture, especially first thing in the morning.**
- **Do not allow very hungry animals to graze a pasture. Offer dry, cut grass first before turning out to graze.**
- **Keep a watch on animals at pasture.**

## **Treatment**

**Making the animal belch is one way of treating bloat. You can do this by:**

- **Massaging the distended rumen through the abdominal wall.**
- **Tying a stick in the mouth, crosswise like a horse's bit.**
- **Tickling the throat.**
- **Make the animal walk around for about half an hour.**

**If these methods fail then give a drench (drink) to the animal (see Drenching Annex 3). The drench used can be one of the following:**

- **Two large spoons of washing up liquid, e.g. Fairy, Lux.**
- **A solution of sodium bicarbonate (cooking or baking soda) and water.**
- **A small amount of kerosene (paraffin) in warm milk.**
- **A small bottle of peanut, soya or linseed oil.**
- **A very small amount of turpentine in either linseed oil,**

**soya oil or peanut oil.**

- **Use a commercially, available medicine (see R20, Annex 1).**

**In severe cases the animal may not belch and it will die. In such cases puncturing the left flank with a sharp knife or trocar and cannula to release the gas is necessary, it will be necessary for you to act quickly as any hesitation could lead to the death of the animal.**

## **Treatment**



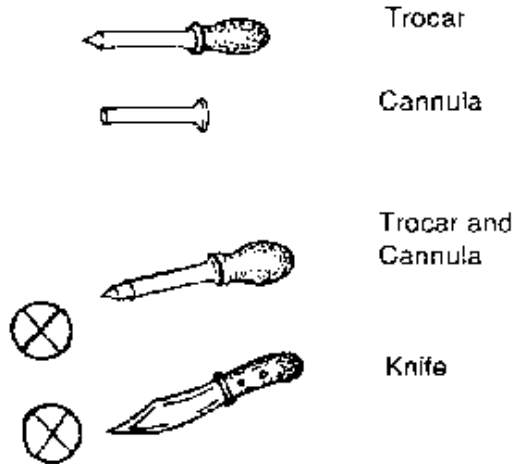
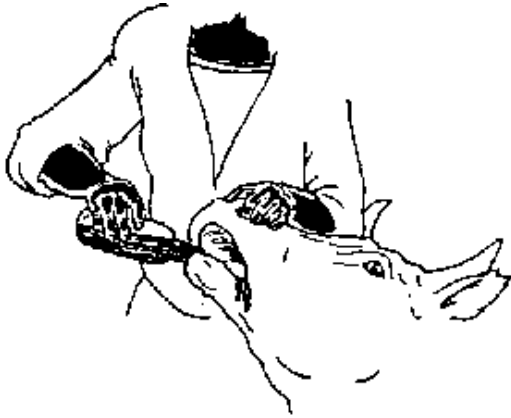

Sometimes tympany occurs because large pieces of feed block the gullet (oesophagus). If this happens try to massage the neck to remove the blockage.

## Unit 9: How to age sheep, goats, cattle and buffalo

***The age of animals can be determined by examination of the front teeth.***

***You will not be able to determine the exact age, especially in***

## ***older animals.***

### **Learning objectives**

**After studying this unit you should know:**

- 1 How to hold animals to check the teeth.**
- 2 The difference between the temporary (milk) teeth and the permanent teeth.**
- 3 How to age sheep, goats, cattle and buffalo.**

**How to hold (restrain) the animals to check their teeth**

**How to hold sheep and goat to check their teeth**



## **How to hold cattle and buffalo to check their teeth**



## **Temporary (milk) and permanent teeth**

**Young animals, like children, have temporary or milk teeth which will be replaced by permanent teeth.**

**Young ruminants have 20 temporary teeth, adult ruminants have 32 permanent teeth.**

**Temporary (milk) teeth:**

**Upper jaw No front teeth 6 back teeth**

**Lower jaw 8 front teeth 6 back teeth**

**Permanent teeth:****Upper jaw No front teeth 12 back teeth****Lower jaw 8 front teeth 12 back teeth**

***Remember that you will not be able to determine the exact age of the animal from its teeth, but there will be a few months either way.***

***You should develop the habit of regularly checking the teeth (not just for age) because bad or worn teeth will stop an animal eating or chewing the cud. Such an animal is of no use.***

**Age of goats and sheep**

- (1) Animal under one year old (no permanent teeth)**
- (2) One year old (2 permanent teeth)**
- (3) Two years old (4 permanent teeth)**
- (4) Three years old (6 permanent teeth)**
- (5) Four years old (8 permanent teeth)**
- (6) Old animal, more than four years old**

# Age of goats and sheep

---

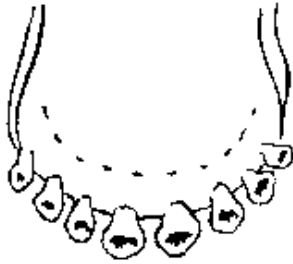

1

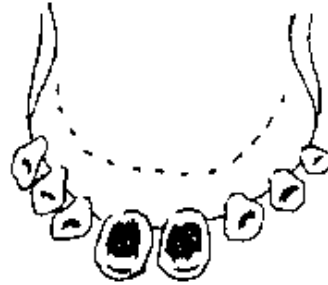

2



3



4

||

||

||



5



6

## Age of cattle

- (1) Under two years old (No permanent teeth)
- (2) Two years three months (2 permanent teeth)
- (3) Three years old (4 permanent teeth)
- (4) Three years six months (6 permanent teeth)
- (5) Four years (8 permanent teeth)
- (6) Old animal, over four years old.

## Age of cattle





1



2



3



4

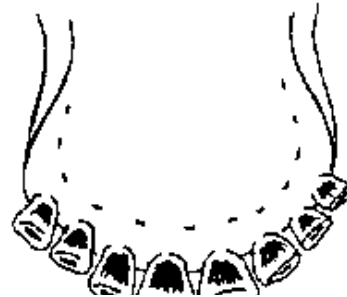



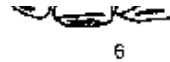

## Age of buffalo

- (1) Under three years old (no permanent teeth)
- (2) Two years six months (2 permanent teeth)
- (3) Three years six months (4 permanent teeth)
- (4) Four years six months (6 permanent teeth)
- (5) Five to six years (8 permanent teeth)
- (6) Old animal

## Age of buffalo

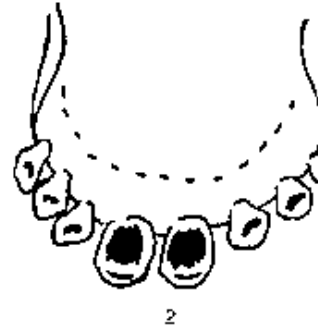
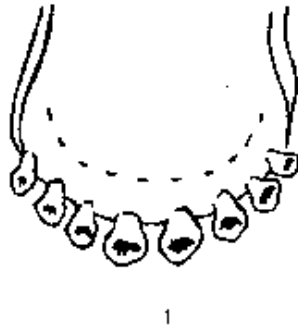



3



4



5

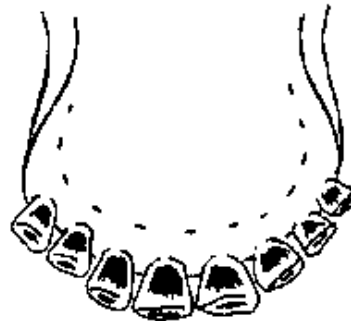

6

## Unit 10: Restraining cattle and buffalo

***Handling cattle and buffalo may lead to stress and injuries***

***especially if the animals are not used to being handled and the handler is not experienced.***

***There are different techniques used to restrain and cast (throw) these large ruminants.***

## **Learning objectives**

**After studying this unit you should know:**

- 1 How to hold cattle and buffalo.**
- 2 How to safely use the halter.**
- 3 How to cast (throw) the animals with ropes.**

## **Restraining (controlling) large ruminants**

**The crush or race is made of wood or metal. You should have one in your village or settlement, if not you should talk to the elders of the community about making one with the help of a veterinarian. Crushes are used for large ruminants when they are vaccinated, examined or undergo other treatments.**

## How to hold animals

If you do not have a halter or a nose holder the best way to hold a large ruminant is to take a firm grip of the nostril using the thumb and forefinger of one hand while holding the horn or the ear with the other hand.

### How to hold animals

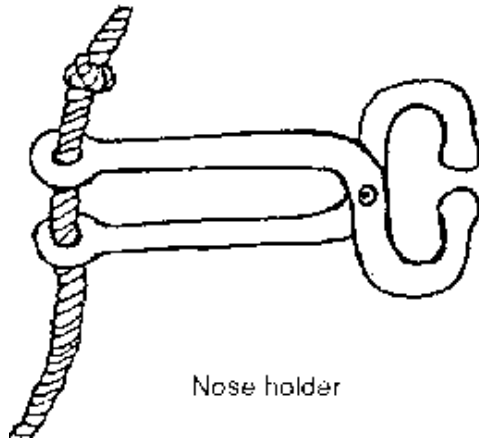

## Haltering large ruminants (cattle and buffalo)

**Animals need to be halter-trained and this is best done when they are young so that they are accustomed to the halter. When a halter is used on an animal talk to the animal to encourage it to move. Hold the halter no more than 20 cm from the animals cheek and walk close to its neck.**

### **Haltering large ruminants (cattle and buffalo)**

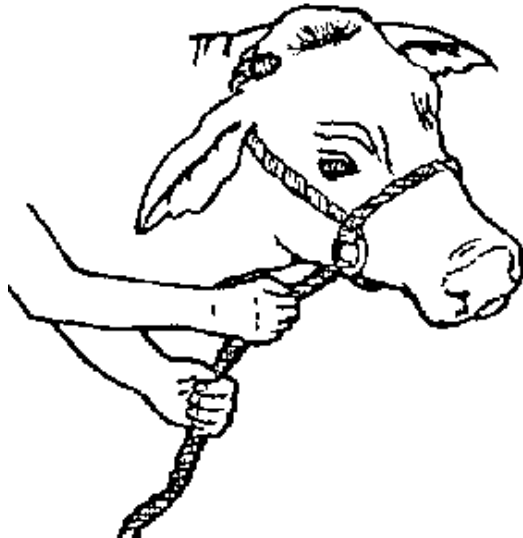

## **Casting or throwing cattle and buffalo**

**If you do not have a crush and you want to trim the hooves of an animal it will be necessary for you to cast (throw down) the animal.**

**To do this you will need:**

- **A halter for the head.**
- **Two people to help you.**
- **Ten to twelve metres of strong rope.**
- **A place where it is safe to throw the animal, where the soil is soft or covered with straw.**

**First halter the animal then tie the long rope around it as shown in the illustration below. Have one person to hold the halter while the other joins you and pulls the rope. The animal will collapse onto the floor and your helper must immediately put his knee on its neck and his hand on the animal's head to prevent it from rising.**

***Do not leave the animal down for a long time as bloat may develop.***

## **Casting or throwing cattle and buffalo**

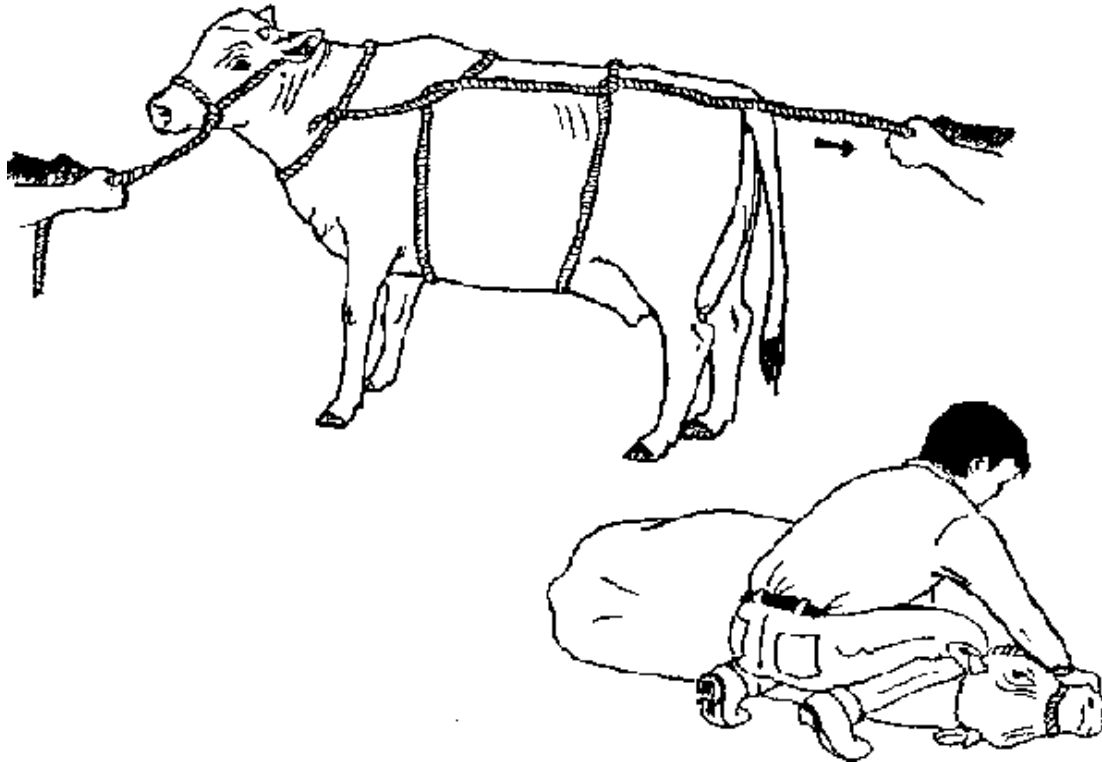

***Remember when casting animals that both the animal and people can get injured so try to do it safely.***



## Unit 11: Foot (hoof) care

***There is an old saying "No foot, no animal". This is true as untrimmed feet lead to bad legs and the animal cannot graze properly and will lose condition.***

***The feet should be regularly examined and trimmed.***

***Remember to make any cuts in a direction away from your body or the hand holding the foot.***

### Learning objectives

After studying this unit you should know:

- 1 Why overgrown feet are bad.**
- 2 How to hold or cast animals in order for the feet to be trimmed.**
- 3 How much of the foot (hoof) can be removed.**

### Overgrown feet

**The hoof is like your fingernail and grows continuously. Walking wears the hoof down but sometimes the hoof grows very quickly and becomes overgrown. In some places where the ground is too wet the foot can get infected and it becomes smelly and painful. This condition is called foot rot and the animal can become lame.**

**When animals have infected or overgrown feet they cannot walk and graze properly. The male cannot mount the female and is useless.**

**How to hold or cast animals in order to trim the feet**

**You can trim the feet of sheep and goats alone or with someone to help you. Grasp the wool or hair on the chest with one hand while holding the animal on its flank with the other hand. Use your knee to push against the animal's back and force it into a sitting position. The animal can be kept in this position for a long time while the feet are trimmed.**

**How to hold or cast animals in order to trim the feet**

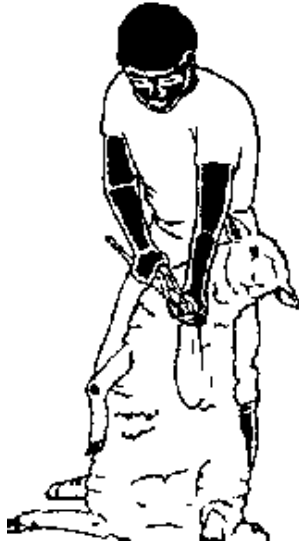

Bad



Good



Bad



Good

**In order to trim the feet of cattle or buffalo you will need to cast the animal (see Unit 10). The leg may be lifted and tied as shown.**

**How to hold or cast animals in order to trim the feet**

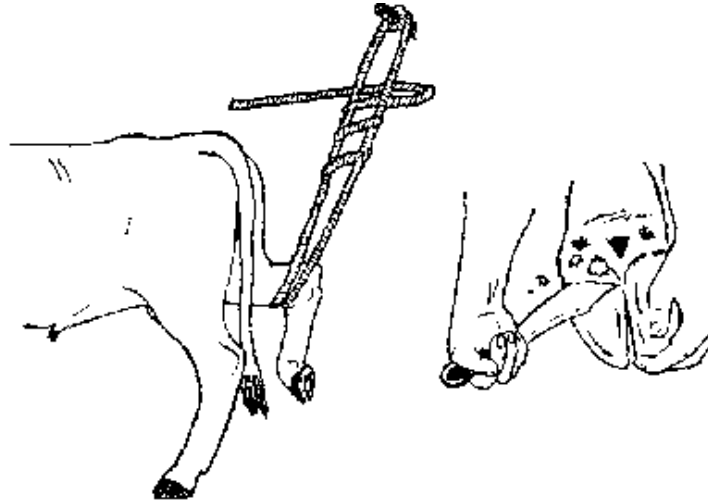

## Trimming the feet

**You will need any suitable sharp tool such as a knife, hoof cutter large carpenter's rasp, or sharp carpenter's pincers.**

**Cut the overgrown claw of the hoof by carefully taking off a little at a time. STOP if bleeding occurs. Do not cut down too far. Like your fingernail the hoof has a sensitive area which if cut into will become painful and infected. STOP if the foot (sole) springs back**

**when pushed with the thumb. When you have cut the hoof down use a rasp, if you have one, to file and neaten the edge of the hoof.**

## **Trimming the feet**

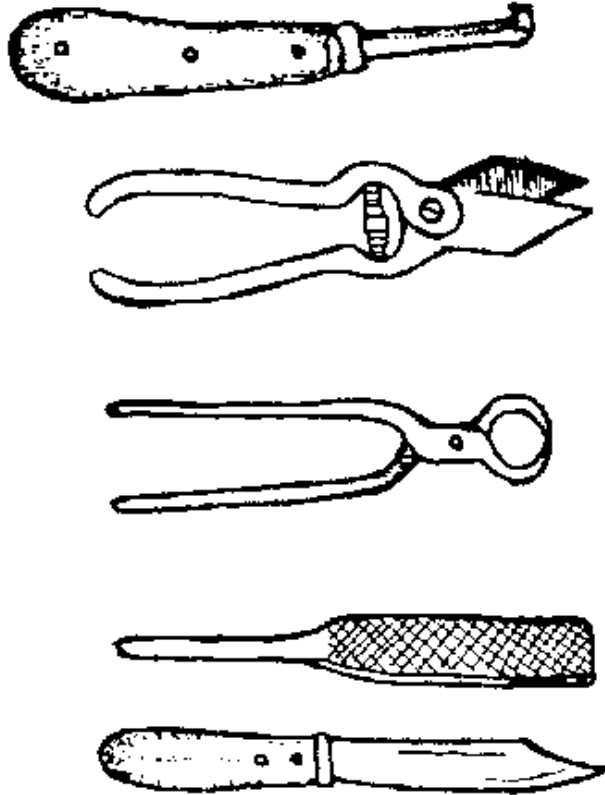

**If the foot is infected and wet and smelly you should carefully remove the damaged areas so that the infected area is exposed**

**to the air. The infected area should then be painted with tincture of iodine or formalin (see R4, Annex 1). Repeat the treatment every 2 days.**

***Remember to use whatever tools you can and look after the animals' feet. If you regularly check the feet and keep them trimmed you will not have any problems. If you have sheep, and there is a lot of foot rot in your area, ask your veterinary service for ad vice and a vaccine against foot rot.***

## **Unit 12: Shearing and dagging (crutching)**

***Woolly sheep naturally lose their coats in the warmer months so before this happens we shear the sheep in order to take the wool for a variety of uses.***

***If the wool becomes dirty with dung and wet it attracts flies which lay eggs in the wool. The eggs develop into maggots which feed on flesh of the sheep.***

### **Learning objectives**

## **After studying this unit you will know:**

- 1 Why we shear sheep.**
- 2 What is dagging (crutching).**
- 3 What happens if we do not dag or cheer the animal.**

### **Why do we shear sheep?**

**Wooly sheep must be sheared at certain times of the year. If we do not shear them the wool or hair will be lost in patches and a valuable material will be lost.**

### **Dagging (crutching)**

**Dagging or crutching is the cutting away of dirty, wet wool from around the tail and anus (crutch) of the sheep. The wet, dirty wool attracts flies especially the blow flies (bright green or blue in colour). The flies lay their eggs on the wool and in one or two days maggots hatch from them. The maggots burrow into the skin and feed on the flesh of the sheep. The animal will be smelly, nervous, stamping its feet and wriggling its tail.**



**Maggots must be removed from an infected sheep. Part the wool and look for the small holes where the maggots have entered the skin. Press all round the hole with your fingers and the maggots will come out. Many maggots of different sizes will emerge. Clean the wound (Unit 73) with tincture of iodine or gentian violet (see R1, Annex 1).**

## Dagging

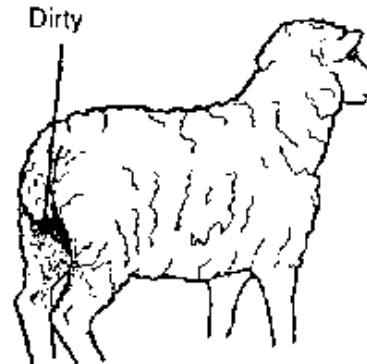
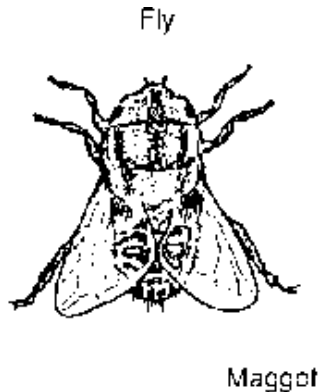

## Shearing

**Shearing is the complete removal of the wool and is carried out using machine or hand shears. The valuable wool can then be used for clothing, carpets etc. Make sure that the wool is kept clean by not using too much marker paints on the animal and if it is your custom to wash your animals before shearing make sure that you wash them three or four days before shearing. After shearing keep the sacks of wool in a dry place on plastic sheets to stop them getting damp.**

**If the animal is cut during shearing treat all wounds immediately with tincture of iodine or gentian violet (see R1, Annex 1).**

***If you have the means to dip your sheep do it immediately after shearing.***

### **Unit 13: Dehorning calves, lambs and kids**

***Animals which have been dehorned are quiet and do not fight and cause injury to others.***

***The best time to remove the horns (disbudding) is when the animals are less than one week old.***

## **Learning objectives**

**After studying this unit you will know:**

- 1 Why we dehorn animals.**
- 2 What tools we need to carry out disbudding.**
- 3 How to dehorn animals.**

**Why do we remove the horns?**

**Removing the horns from the animal means that:**

- There is less chance of it injuring other animals.**
- There is less risk of injury to people.**
- An animal without horns needs less space at the feeding troughs.**

**The horns are best removed when still buds (buttons) on the animal which is less than one week old. This is called disbudding.**

## The tools used to disbud animals

To dehorn an animal you will need a dehorning iron which can be heated by electricity or over a direct flame. The end of the iron is round and hollow and will fit over the bud of the horn. *Using a hot iron is better than using caustic soda to remove the buds.*

### The tools used to disbud animals

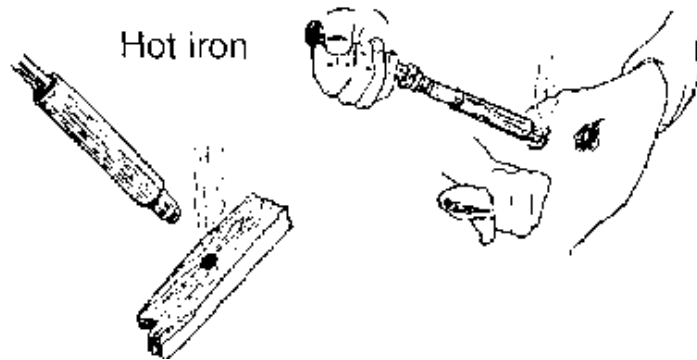

You may have an iron, but if you do not, ask a blacksmith to make one for you.

To test the iron heat it until hot and then hold the end against a

**block of wood. A complete, even ring should be burned into the wood. You will need to test the iron each time you use it to make sure it is hot enough.**

## **Disbudding**

**You will need someone to help you. Take care with the hot iron.**

- **Restrain the animal. Your helper must hold its head and pull the ear nearest the bud you are going to remove, down and away from the bud. He must hold the head very still.**
- **Cut the hair away from around the bud of the horn.**
- **Test the hot iron and when ready put the iron over the bud and twist it around for about 10 seconds. Continue until the bud feels loose, reheating the iron if necessary.**
- **Push the bud out by pressing with the iron.**

## **Unit 14: Castration of ruminants**

***Castration is the destruction or removal of the testicles of the male. It is carried out on animals which are not wanted for breeding.***

***Castrated animals are quiet (do not fight).***

***Some countries insist on all imported animals being castrated.***

## **Learning objectives**

**After studying this unit you will know:**

- 1 Why we castrate animals.**
- 2 When we castrate animals.**
- 3 The way animals are controlled for castration.**
- 4 How to castrate with a knife.**
- 5 How to castrate with a Burdizzo.**
- 6 How to castrate with rubber bands.**

**Why do we castrate animals?**

**Traditionally farmers or animal raisers do not castrate animals**

**and both males and females are allowed to mix together. The result is that poor males (see Annex 4) are allowed to mate with the females and the young stock produced are not very good. Uncastrated males also fight so it is better to castrate the animals which are not the best for breeding.**

**When do we castrate animals?**

**The best time to castrate animals is when they are very young (a few days old). If castration is carried out then, the operation is easier and more successful and the wound heals (gets better) very quickly.**

**Holding and controlling animals for castration**

**You will need another person to help you. It is best to put young lambs and kids on a table covered with sacks. Calves can be castrated when they are standing but the animal must be restrained very well.**

**Holding and controlling animals for castration**



## **Castration with a knife (blood)**

**Use a very sharp knife, razor or scalpel.**

- **Check that the knife, razor or scalpel is very sharp and clean. Clean the blade with a disinfectant such as alcohol, iodine, Dettol or gentian violet.**
- **Use warm water and soap to wipe the scrotum and wash your hands.**



- **Cut the bottom end of the scrotum. Squeeze the testicle above the cut end of the scrotum and it will come out.**
- **Pull each testicle out as far as possible, twist the testicular cord around several times. Cut the cord in cattle and buffalo by scraping the knife slowly up and down. Pull to sever the cord in lambs and kids.**
- **Do not put your fingers inside the open scrotum. Put either tincture of iodine, gentian violet, Dettol or antibiotic powder (R1, R5, R8 Annex 1) on the wound.**

### **Castration with Burdizzo (no blood)**

**The Burdizzo should be used on the young animal. There are Burdizzos for animals of different sizes. You should always remember that the Burdizzo is a valuable instrument and keep it clean and oiled. Do not drop it.**

**To castrate with the burdizzo:**

- **Feel the scrotum with your hand and you will feel the two rope-like testicular cords inside.**
- **Take the Burdizzo in your right hand and with your left hand push the cord to the side between the jaws of the Burdizzo and squeeze hard.**
- **Now take the Burdizzo in the left hand and crush the other cord.**

### **Castration with Burdizzo**

Burdizzo for calf

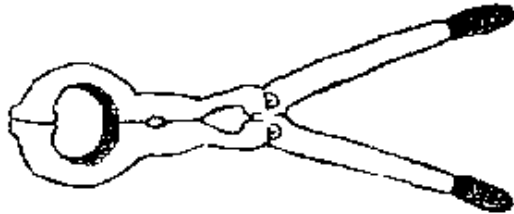

Burdizzo for sheep

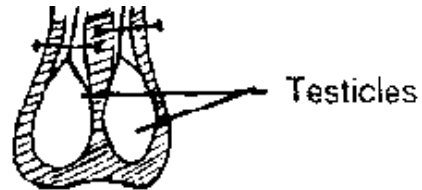

## Castration with rubber rings

To castrate with rubber rings we use a tool called an elastrator. It can only be used to castrate ruminants which are a few days old.

- Put a rubber ring around the four teeth of the elastrator and squeeze the handle. The rubber ring will be stretched open.

- **Pass the scrotum of the animal through the ring making sure that it goes over the two testicles.**
- **Release the elastrator and the rubber ring will tighten over the cords. After two weeks the scrotum will fall off**

### **Castration with rubber rings**

Elastrator

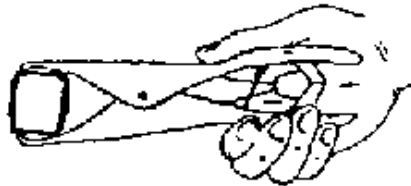

Rubber rings

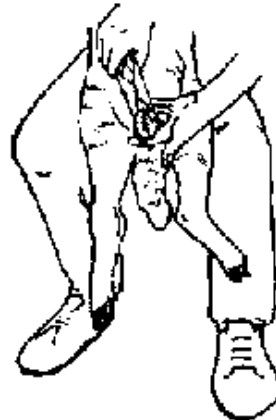

***Check all animals which have been recently castrated for signs of***

***infection.*****Unit 15: Internal parasites of ruminants**

***Small worms can infect sheep, cattle, goats and buffalo, and live in the animal's gut, lungs, liver and blood.***

***These worms are called parasites and the animal they live in is called the host. The parasite feeds off the host which becomes weak, loses weight, develops disease and can die.***

**Learning objectives**

**After studying this unit you should know:**

- 1 What is a parasite.**
- 2 How animals become infected.**
- 3 The problems caused by parasites.**
- 4 How to control parasites.**

**What is a parasite?**

**A parasite lives in or on another animal and feeds on it. All animals and humans can become infected with parasites. Ruminants can be infected with several types of worms.**

**Roundworms are small, often white in colour, and look like threads. Different roundworms are found in all parts of the gut and the lungs.**

**Tapeworms are long, and flat and look like white ribbons. They consist of many segments and live in the intestine.**

**Flukes are flat and leaf-like, they live in the liver. Schistosomes are small and worm-like, both infect animals kept on wet, marshy ground as their eggs develop in water.**

## **Parasites**



Round worms

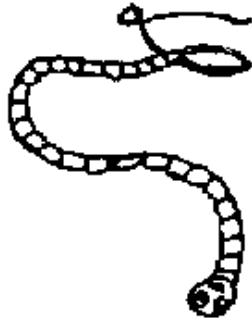

Tape worm



Fluke



Schistosomes

**How do animals become infected with parasites?**

**The roundworms, flukes and schistosomes lay eggs which pass out of the animal in the dung onto the pasture. Tapeworms produce eggs in the segments which break off and pass out in the dung. Animals become infected when they graze the pasture.**

**How do animals become infected with parasites?**



## **The effect of parasites on the animal**

**Parasites feed on the food in the gut and on the blood of the host. The animal becomes weak and loses weight or does not gain weight. It can develop diarrhoea, which in sheep makes the wool wet and attracts flies.**

**Eventually the host becomes so weak that it dies. Young animals are especially affected by parasites.**

## **Control of parasites**



## **We can control parasites by:**

- **Killing the worms within the body**
- **Reducing the chances of the animal becoming infected on pastures**

**The worms can be killed inside the host by giving it a drug (See R11, Annex 1). The drugs are given by drenching, tablets or injection. Ask your veterinarian when and how often you should treat your animals.**

## **In order to cut down the chance of animals becoming infected:**

- **If possible move stock to new pasture every one to two weeks.**
- **Young animals should be separated from old animals and allowed to graze fresh pasture first.**
- **If cattle, sheep and goats are kept in the same area, let the cattle graze the pasture before the sheep, as some worms which would infect the sheep will not infect the**

## **cattle.**

- **If animals are kept in an enclosure, removing the dung and disposing of it will prevent the animals picking up more worms or others becoming infected.**
- **Do not allow animals to graze on marshy ground or on pasture where the grass is very short.**
- **When animals have been treated, turn them out onto fresh pasture**

***Talk to your local veterinarian and he will advise you about controlling and treating parasites in your area. You should tell him if young animals develop diarrhoea or a harsh cough and die.***

## **Unit 16: External parasites of ruminants**

***Ruminants can be infected by several parasites of the skin (external parasites) which feed on the animal's skin and blood.***

***The parasites cause disease, loss of weight, and can lead to***

***death of the animal.***

***The parasites can also carry other infections and spread diseases from one animal to another. Some of these diseases can kill.***

## **Learning objectives**

**After studying this unit you will know:**

- 1 What parasites can be found on ruminants.**
- 2 The problems caused by infection with the parasites.**
- 3 How to treat and control infection with parasites.**

## **The parasites**

**All animals and man can be hosts to parasites which live on the skin. These parasites look like insects.**

**Mites are very small and cannot be seen without a microscope. They live and lay their eggs on the skin.**

**Lice (singular is louse) are big enough for you to see. Man can be infected with the head louse. Cattle, buffalo, sheep and goats can be infected with different lice which attack the body, legs or tail region. Lice live and lay their eggs on the skin amongst the hair or wool.**

### Lice

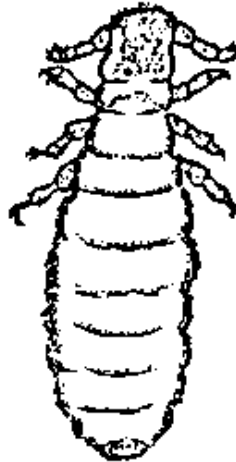

**Ticks are bigger than lice and can be as big as a fingernail. Young ticks have 6 legs while adults have 8 legs. All ticks feed on**

**the blood of the host and then drop off onto the pasture. They lay their eggs on the ground. Some ticks live on one host while others may live on two or three different animals throughout their lives**

**Tick**

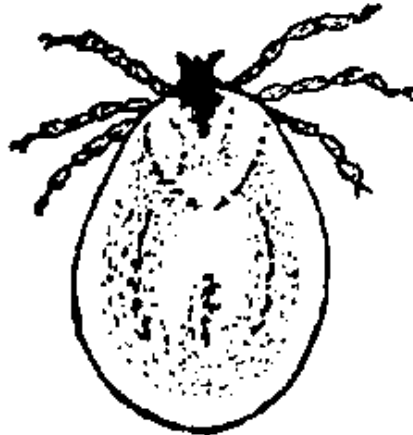

**Problems caused by external parasites**

**Mites cause mange. They infect the head, legs, body or tail**

**region causing the skin to become crusted and cause loss of hair and wool. The infected area itches and the animal scratches. The host does not feed well. The infections cause loss of valuable wool in sheep and damage hides of cattle and goats.**

**Sometimes young animals become infected with a skin disease called ringworm. Ringworm causes circular, whitish patches on the skin which do not itch. Animals can have both mange and ringworm and large areas of skin may be affected.**

### **Ringworm**



**Lice also cause irritation of the skin and the animal scratches,**

**rubs and bites the infected areas. The host loses, or does not gain weight, and looks in poor condition. Both lice and mites can pass from one animal to another. Biting and scratching are the first signs of infection. If you examine the animal you will be able to tell if the skin problem is caused by lice or mites, if lice are on the animal you will find them in its coat, if you do not see any the animal probably has mange caused by mites.**

**Ticks are very important parasites. They bite the host and suck its blood and when full drop off onto the pasture where they can live for many months without feeding again. Animals can be poisoned or paralysed by the bites of some ticks. Ticks also spread diseases, tick-borne diseases, which can cause death of the host. Ticks cause the loss of meat, wool, milk and leather.**

### **Treatment and control**

**Mites and lice are controlled by washing the infected area, spraying or dipping the animal (see Dipping, Spraying Annex 3) with a suitable treatment (R15 Annex 1). All of the flock or herd must be treated to ensure control. Some animals can be infected**

**but show little or no sign of infection and the parasites will spread from them to other animals if they are not treated too.**

**If an animal has only a few ticks these can be carefully pulled off making sure the mouthparts of the tick are removed. Rubbing ticks with a cloth soaked in kerosene (paraffin) will make them drop off the host. Large numbers of ticks are treated using sprays and dips (See R16 Annex 1). It will be necessary to treat all of the herd or flock.**

**Moving animals to different pastures and resting the contaminated pasture for a length of time can help to control the ticks. Cutting the bushes and ploughing the affected area can help to control ticks. Large numbers of ticks can be found around water holes and animal shelters. Keeping poultry in these areas can help to reduce numbers of ticks as the birds will eat them.**

***If mange or ticks are a problem in your community's livestock you should talk to your local veterinarian about it. He will advise you on the best treatment and control to use in your area. He may ask you to collect some ticks or take scrapings of skin from animals***



***with mange so the parasite can be identified. This will help him to decide which treatment you should use.***

## **Unit 17: Signs of heat (oestrus) in ruminants**

***Heat or oestrus is the period when the female will accept the male and mate.***

***There are signs which mark oestrus in all ruminants. Recognising when the female is on heat means you will know when to put her with the male or use artificial insemination.***

### **Learning objectives**

**After studying this unit you should know:**

- 1 What is heat or oestrus.**
- 2 Recognise when a female animal is mature and comes in heat.**
- 3 Know what the signs of heat are in different ruminants.**
- 4 How long oestrus lasts in different animals.**

## **What is heat?**

**The female reproductive system (see Unit 3) consists of two ovaries and a womb. Every so often the ovaries produce very small eggs (ova). The time when this happens is called heat or oestrus.**

**Cattle and buffalo regularly come into heat all year round. Most sheep and goats come into heat at a particular time of the year (breeding season).**

### **Knowing when an animal is in heat**

**If you know when an animal is in heat you can introduce her to a chosen male for mating or you can arrange for her to be artificially inseminated if the service is available. You will also be able to identify animals which do not go in heat.**

**The best time to look for signs that the female is in heat is early morning or in the evening. Take care not to disturb the animals but just watch the animals for the signs.**

## **Signs of heat**

**Ruminants can be kept on pasture or they may be stabled or tied up for most of the time. It is therefore necessary to consider this when looking for signs of heat:**

### **1. Signs of heat in free animals (at pasture):**

- **Most females in heat will allow other animals to mount them.**
- **Cows in heat will mount one another, from the rear or from the front. However the cow on top may not be on heat.**
- **The vulva becomes swollen and the area around the tail becomes wet and dirty.**
- **If cows sniff each others' vulva and urine they may both come into heat.**
- **Cows can be coming into heat if they stand resting the**

**chin on the back of another or are seen to lick or gently butt each other.**

- **Restlessness and calling loudly can also mean the female is coming into heat. Goats in particular become very noisy.**

### Signs of heat





Coming on heat



Coming on heat

## **2. Signs of heat in the stabled or tied animal:**

**The animals should be allowed out twice a day when they can be watched for signs of heat. If the female is not allowed out then the following will show that she is in heat:**

- **Swollen vulva.**
- **The animal is active, there is a loss of appetite and she calls loudly.**
- **In milking animals the amount of milk produced**

**suddenly drops.**

- **A jelly-like mucous can be found on the floor with the dung.**

**You will need to be able to recognise the differences between signs of heat and signs of ill health in the animal which is tied up.**

**When do animals come into heat for the first time?**

**Animals come into heat when they reach puberty. This occurs at different ages in the different ruminants:**

- **Well fed cows and buffalo come into first heat at 10 - 20 months of age.**
- **Sheep and goats come into first heat between 6 - 12 months of age.**

**How long does heat last?**

**The duration of heat is very short.**

- **In cows and buffalo it lasts for less than a day.**

- In goats heat lasts for 1 - 3 days.
- In sheep heat lasts for 1 - 2 days.

**A healthy animal which was not mounted by a male or given artificial insemination will come back into heat. Cattle and buffalo cows will come into heat after 3 weeks (give or take a day or two), and female goats and sheep will come back into heat after 17 days (give or take a day or two).**

**The female which does not come into heat**

**The female may not show signs of heat because she is too old, or she may have been mated without the owner knowing. Sometimes animals come into heat without showing any signs. This is called a "silent heat" and is common in buffalo cows. If the feed is not sufficient or there is a lack of protein, salts or water, the animal can fail to come into heat. You will need to improve the female's feed to bring it into heat.**

***If young, well fed females do not come into heat or do not become pregnant you should ask your local veterinarian for***

***advice.***

## **Unit 18: Pregnancy in ruminants**

***When the animals mate sperm from the male joins with the eggs in the womb.***

***Heat then finishes and the belly of the female enlarges over several months as the young grow during pregnancy.***

### **Learning objectives**

**After studying this unit you should know:**

- 1 What happens during pregnancy.**
- 2 The signs of pregnancy.**
- 3 Management of the pregnant animal.**

### **What is pregnancy**

**When the male mates with the female he deposits sperm in the vagina. The sperm joins with the egg and forms the embryo**



**which becomes attached to the wall of the womb. The embryo grows within a bag of fluid (water bag) and is attached to the wall of the womb by a navel cord.**

## **Signs of pregnancy**

**Heat stops when pregnancy begins. The animal becomes quieter and the belly grows bigger. In milk animals the production of milk will gradually drop.**

## **Length of pregnancy**

**If male and female animals have been allowed to run together in a large herd it will be difficult to determine the expected time for birth (parturition). If however you do know when a female was mated or given artificial insemination you can determine when she will give birth.**

**The length of pregnancy differs in different animals.**

<b>Animal</b>	<b>Length of pregnancy</b>
<b>Cow</b>	280 days

<b>Buffalo</b>	320 days
<b>Sheep</b>	150 days
<b>Goat</b>	150 days

***There can be a few days difference either way depending on the type, climate, feed and other factors.***

### **Management of the pregnant animal**

**You must remember that a pregnant animal will need more feed and will benefit from the addition of some grain to the feed towards the end of pregnancy. All pregnant animals should be kept close to home towards the end of the pregnancy and some form of shelter should be provided. They should be watched twice a day for signs that parturition is close. In particular cattle and buffalo need a clean, well ventilated place, preferably with a sand or grit floor on which suitable bedding is placed.**

**Do not keep a pregnant animal constantly tied up or with little room to exercise in. Allow her some freedom in a field or yard**

**each day. She should be observed closely twice a day for signs of parturition.**

## **Unit 19: Calving (parturition)**

***Calving is a natural process which normally takes place without help. Close observation is required in case the cow has difficulties.***

***Cows calving for the first time (heifers) tend to have more problems than older cows and therefore need more attention when calving.***

### **Learning objectives**

**After studying this unit you should be able to:**

- 1 Know the signs of calving.**
- 2 Recognise a normal calving.**
- 3 Help the cow which has difficulty in calving.**
- 4 Care for the cow immediately after calving.**

## **5 Care for the newborn calf.**

### **The signs of calving**

**You will know that the cow is about to calve or give birth when you see:**

- **The belly has increased in size, especially on the right flank.**
- **The udder is filling up and the teats are stiffening.**
- **The vulva becomes red and swollen with the presence of mucous and blood coloured fluid.**
- **The animal is restless.**
- **The water bag appears at the vulva.**

### **Normal calving**

**The water bag appears through the vulva. The cow will strain more. The head of the calf will appear and this breaks the bag. You will then be able to see both of the calf's front feet. It takes 4 - 6 hours for the calving to reach this stage. In heifers it might**

**take longer. As the chest comes through the vagina the calf starts to breathe.**

### Normal calving



***It is better to leave the cow alone to give birth naturally.*** However if you want to help with the calving you can gently pull the calf by its feet. If the navel cord (see Unit 18) is still attached to the cow you can cut it with a clean sharp knife or a pair of scissors, then put tincture of iodine or alcohol on the end of the navel cord.

Sometimes the back feet of the calf appear first. You can tell the back feet from the front by looking carefully. You will see that the back feet come out from the vulva with the soles of the feet showing uppermost. You should then look (or feel with your hands) for the tail and the hock joints.

### **Difficulties in calving**

Leave the animal to give birth naturally. If difficulties occur you may find:

- (1) Only the head of the calf has appeared.**
- (2) The head and one foot has come out.**
- (3) Two front feet showing but no head.**

**If this happens you should either ask the veterinarian to help or**

## help the cow yourself

### Difficulties in calving

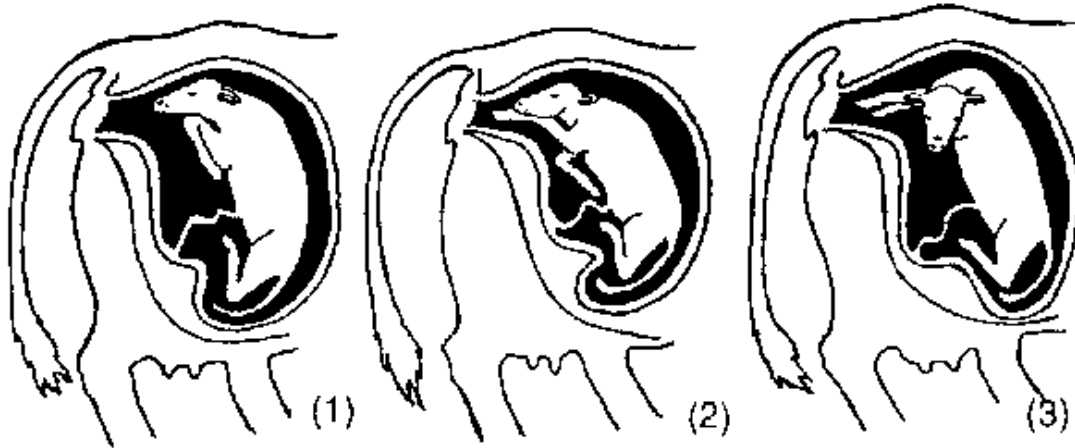

**You will need a bar of soap, hot water, a clean rope and clean vegetable oil such as olive or sunflower oil.**

**Wash the area around the vulva and wash your hands well. Make sure that your fingernails are cut short and are thoroughly clean. Long nails can injure the animal. If you have oil put some over**

**your hand and arm, if not, soap your hand and insert it into the vagina to discover what is wrong.**

**You will need to recognise the difference between the front and back legs of the calf in the womb. Touch the fetlock joint and then run your hand up the leg to the next joint. There will be a knee joint on the front leg and a hock on the back leg. Push the calf either to one side or back into the uterus so that you can correct the situation and move the head and legs into the right place for birth.**

### **Difficulties in calving**



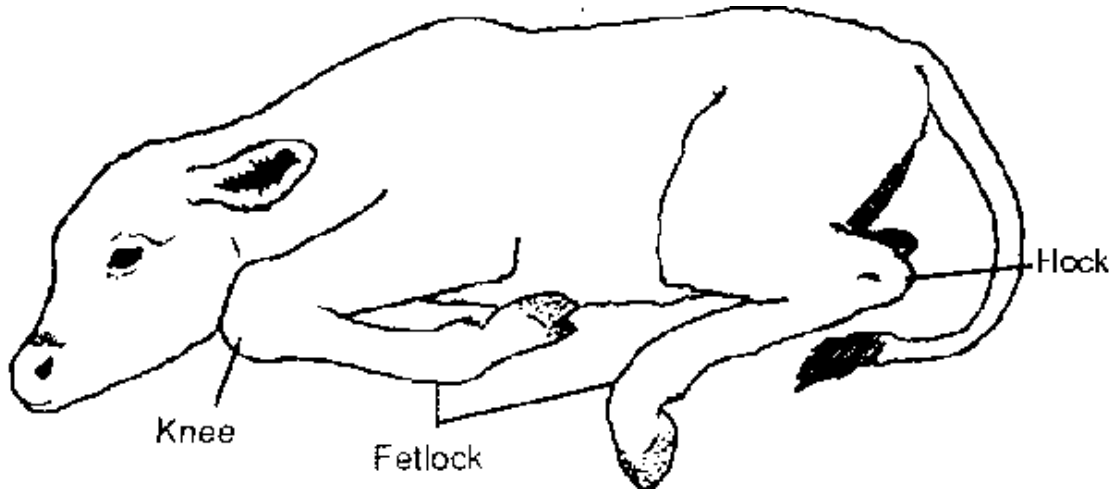

**When the calf's head and legs are in the correct position tie a clean rope around both feet. Pull gently on the rope. You may need someone to help you pull.**

***Sometimes the water bag will burst but neither the feet nor the head will have appeared. This is a very difficult position to sort out and if you can you should immediately ask your veterinarian for help.***

**Caring for the cow after calving**

**Give the cow clean water to drink immediately after she has calved as she will be thirsty.**

**The water bag (afterbirth) will come out naturally but you can help to remove it by gently pulling it. The afterbirth should have come away by 24 hours after the birth. If the afterbirth remains in the uterus it will cause an infection and you will need to get your veterinarian to help.**

**Caring for the newborn calf**

**Always handle the calf carefully. Clean the mucous (sticky fluid) from the nose and mouth and check that the calf is breathing normally. If it is not breathing you must act immediately by:**

- **Pump the chest with the palm of your hand.**
- **Keep the calf's head lower than its back.**
- **Insert a straw into its nose in an attempt to make it sneeze and start breathing.**

**Allow the calf to suckle from its mother as soon as possible so**

**that it takes in the colostrum, the yellowish milk which is produced immediately after birth. The colostrum is rich in protein and protects the calf against disease.**

**Some people use the colostrum for their food but it is essential to make the calf strong and healthy and should be left for the calf.**

***You must allow the calf to take colostrum for at least four days after its birth.***

## **Unit 20: Lambing and kidding (parturition)**

***Lambing and kidding, like calving, are natural processes which normally take place without help. Observation is required in case there are any difficulties.***

***Sheep and goats, unlike cattle and buffalo, may frequently have twins (2 young) or triplets (3 young).***

### **Learning objectives**

**After studying this unit you should be able to:**

- 1 Recognise the signs that parturition is beginning.**
- 2 Know when parturition is normal.**
- 3 Assist with parturition when necessary.**
- 4 Care for the mother and newborn.**

## **Signs of parturition**

**You will know when the goat or sheep is about to give birth as:**

- The animal keeps away from others.**
- The vulva is swollen and the skin is loose.**
- The animal becomes restless and does not eat well.**
- A discharge from the vulva will start a few days before parturition.**
- The sheep will lie down and stretch the neck back to look at the sky (star gazing) and lick its lips.**
- The sheep will strain to push out the lamb.**

## **Star gazing**

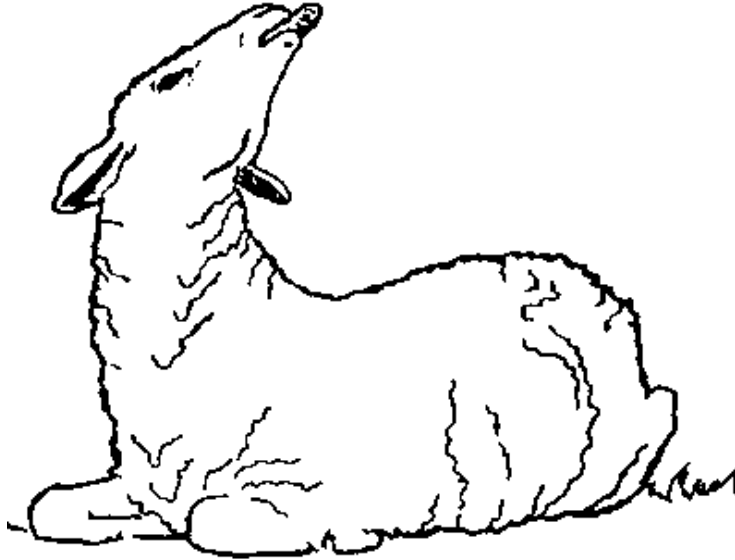

## **Normal parturition**

**Animals may give birth while standing or lying down. The head and both front legs appear while sometimes both the hind legs will appear. The young mother may have some problems in giving birth.**

## **When and how to help in parturition**

**As with calving (see Unit 19) the young may be in an abnormal position and the birth is difficult. If you want to help you will need a bar of soap and clean water. Scrub your hands and fingernails then wash the area around the vagina. Soap your hands well and insert one hand into the vagina. When you have found what the problem is, correct the position of the young so it can be born. Carefully feeling for the leg joints will tell you which way round the young is.**

**You can hold the head but do not pull the young by the jawbone as the bone will break. You can use a clean rope tied around a leg above the fetlock joint to pull. Pull in a downwards direction as the mother strains.**

**If there are twins or triplets in the uterus you will have difficulty sorting out which legs belong to which one. Try to pull out the one nearest the vagina first. A newborn animal should try to breathe immediately after it is born, if it does not breathe you can put a straw into a nostril (nose) to stimulate breathing. If you hold it by the back legs and swing it gently back and forth, any mucous blocking the mouth and lungs will be forced out.**

## When and how to help in parturition

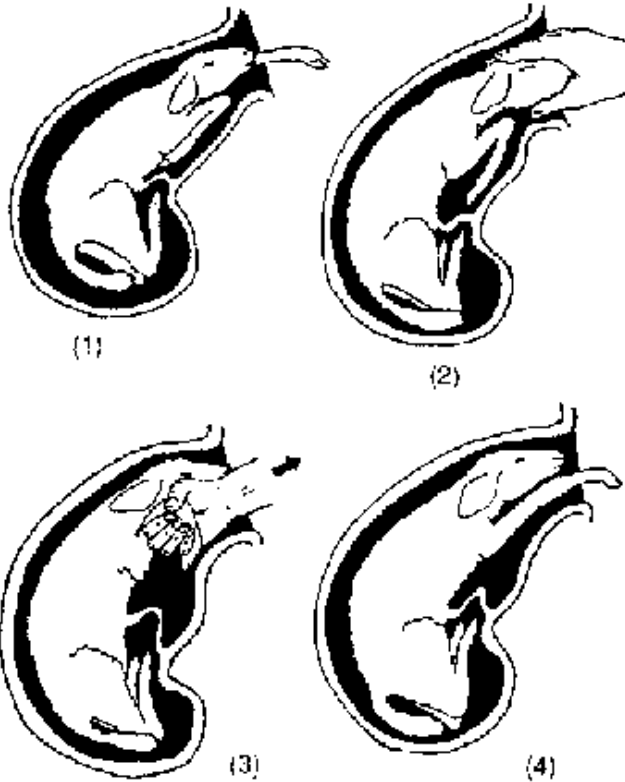

### Care of the mother and newborn

**Immediately after giving birth the mother should be given fresh clean water. Check that she is producing milk from both teats and allow the newborn to suckle colostrum (see Unit 19).**

***If the teats of a goat are fat with milk the young may have difficulty in suckling. Squeeze a little milk out so the kids can suckle easily. If she has produced triplets try to foster one (see Unit 21) on another mother.***

**If the mother had difficulty giving birth check that there are no dead young still in the uterus. If there are, remove them as they will cause an infection which will kill her.**

**The afterbirth should come out within 3 hours. If it has not appeared after 14 hours you will need to get veterinary help. There will be an afterbirth for each of the young the mother gave birth to.**

## **Unit 21: Care of the newborn**

***From birth the young animal is vulnerable to disease. It is***



***completely dependent on the mother for food and if the mother dies the orphan will need a foster mother if it is to survive.***

***Operations such as castration, cutting the tail and disbudding the horns must be done at a very early age to avoid unnecessary risks and least stress to the animal.***

## **Learning objectives**

**After studying this unit you should be able to:**

- 1 Check the navel cord of the newborn.**
- 2 Check the young for extra teats.**
- 3 Know how to foster (find new mother) for orphans (motherless young).**
- 4 Caring for orphans.**
- 5 Feeding the newborn.**

## **Checking the navel cord**

**Ideally the navel cord of the newborn animal should be dressed with tincture of iodine, gentian violet or Dettol immediately after**

**birth. This should be repeated 2 to 3 days later. After 1 week the cord should have dried and dropped off. If infection has developed, treat it as a wound (see Unit 73).**

## **Checking for extra teats**

**Some female ruminants are born with one or more extra teats. This is especially the case with calves.**

**The extra teat(s) can be removed by:**

- **Restrain the animal firmly.**
- **Identify the extra teat(s) for removal.**
- **Use a pair of clean, sharp scissors to cut off the teat flush with the skin.**
- **Dress the wound with tincture of iodine or antibiotic powder.**

## **Fostering**

**Fostering of the young animal will be necessary if the natural mother has died or fails to produce enough milk for her young.**

**The sheep or goat can only properly feed two young so any other young must be fostered. Fostering can be done by:**

- **Remove the skin of the foster mother's dead young and tie it around the orphan. After several days remove the skin.**
- **Rub the orphan with the afterbirth and fluids or under the tail of a mother who has just given birth. Allow the orphan to suckle with its back towards the mother's head so that she can smell it. This method is mainly used with sheep and goats.**
- **The foster mother can be tied up by the head in a small pen or shed and the orphan left with her. The orphan will usually suckle if the foster mother is prevented from kicking or moving away. This method can be used with sheep and goats but is also successful with cattle and buffalo. In the case of large ruminants tying a rope around the belly will stop the mother from kicking the calf as it suckles.**

- **Place the orphan and the foster mother in a small shed or pen and tie or leave a dog with them. The female will protect the orphan from the dog and will then allow it to suckle.**

## **Hand rearing orphans**

**If no foster mother is available the orphan will need to be fed by hand. You must make sure that the orphan has colostrum, if possible for 4 days or 8 feedings. Collect the colostrum from other mothers into a clean bottle. Do not boil colostrum as it will curdle.**

**Lambs and kids can be fed warm milk from a bottle fitted with a rubber teat or nipple. Clean the bottle thoroughly after each feeding. They will need 4 to 6 feedings a day.**

**Calves can also be fed from a bottle but it is best to get them used to drinking milk from a bucket when they are a few days old. To get the calf to drink from a bucket get it to suck your fingers and then as it sucks gradually put your hand into the bucket of**

**milk. Do this several times, holding the bucket at knee height, and the calf will feed from the bucket after a few lessons. The calf will need feeding 3 to 4 times a day. Clean and wash all bottles and buckets after each feeding.**

### Hand rearing orphans

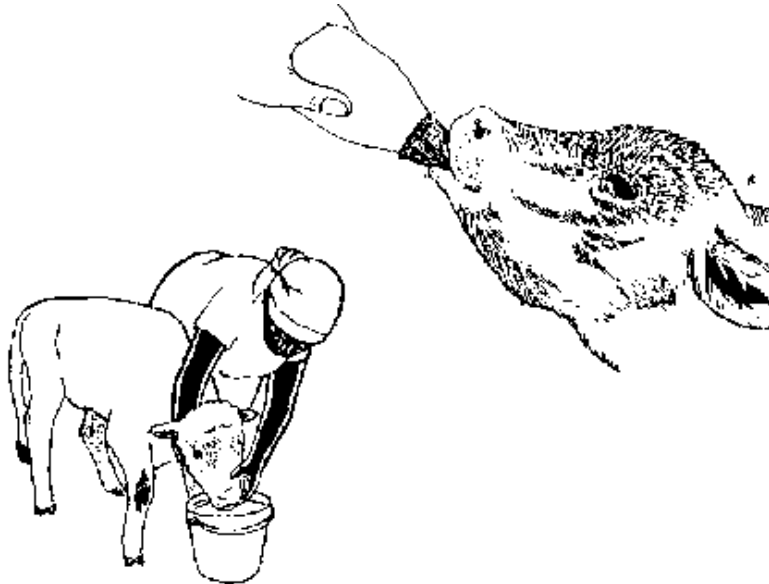

### Feeding calves

**The stomach of the calf needs time to develop fully and become able to digest plants. At first it can only digest milk and a 2 month old calf will drink 4 to 6 litres of milk daily. The calf should be allowed to take all the milk it needs from his mother for the first two months of its life.**

**From 3 weeks of age a calf will begin to eat a little grass and by 3 months of age a calf can eat plants and ruminate. At this age the calf can be weaned. It is allowed to take less milk and is given solid food which is increased until drinking milk is stopped. It can be given grain during weaning. If the calf is left with the mother it will not be fully weaned until it is 8 to 12 months old.**

### **Feeding lambs and kids**

**Lambs and kids will suckle from the mother until they are 4 months old, but they will start to show an interest in green plants from 3 weeks of age.**

***Remember that most newborn animals die because of lack of food. Cold and wet conditions are very bad for the newborn and***

***can cause lung diseases which may kill the animal.***

## **Unit 22: Milk production and the udder**

***The main purpose of the milk is to feed the young. A good milking animal can produce more milk than her young need.***

### **Learning objective**

**After studying this unit you should know:**

- 1 How milk is made.**
- 2 How milk yields can be different.**
- 3 The problems of infection (mastitis) of the udder.**
- 4 Ways of using milk.**

### **How milk is made**

**The udder of the cow and buffalo has four quarters, each quarter having a teat. In the sheep and goat the udder is divided into two with two teats.**

## How milk is made

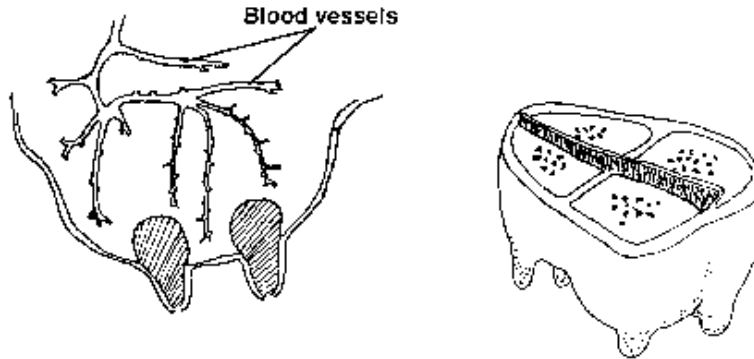

**Milk is produced in the udder from nutrients in the blood which flows through the vessels (tubes) in each quarter. The greater the amount of blood passing through the udder the greater the amount of milk which is produced. The milk is released as the teat is sucked or squeezed.**

**Milking by hand will take from 5 to 10 minutes. The udder should be emptied at each milking and this will stimulate the udder to develop more milk. Always milk the animal quietly. A good time to milk is in the morning before the animal goes out to graze and in**



**the evening. Always milk at the same time each day.**

## **Differences in milk yields**

**Milk yields will vary for different reasons:**

- **Some types or breeds of animals produce more milk than others.**
- **Milk production will be greater after the birth of the second or third young.**
- **Extra good feed, minerals and a lot of water are needed by the animal in milk in order to produce milk.**
- **Milk production improves when the animal gives birth in the rainy season when there is a lot of feed available.**
- **Talking, singing or whistling to the sheep, cow, goat or buffalo as it is being milked makes it relax and the milk is let down better.**

- **Some individuals naturally give more milk than others. These individuals should be selected for breeding (see Annex 4).**

## **Infection of the udder (mastitis)**

**A good udder is essential for milk production. If the udder is injured or infected milk production can stop.**

**Infection of the udder is called mastitis and is caused by germs. Mastitis can be recognised by:**

- **The milk is not clean, the colour is different and there may be lumps in the milk**
- **The udder is hot, painful and swollen.**
- **The skin of the teats is cracked.**
- **The animal may stop eating.**

**More than one quarter of the udder may be infected. The mastitis may be caused by a germ which is infectious and spreads to other animals. Goat milk must be closely looked at for signs of**

**mastitis because the milk may not show a noticeable change in colour.**

**To stop mastitis or to reduce the chances of it occurring the following steps should be taken:**

- **The hands of the milker should always be clean.**
- **The udder should be washed with warm water and dried before the animal is milked.**
- **Any animal with mastitis (or other disease) should always be milked last.**
- **Treatment of mastitis will be successful if it is started early.**

**Infection of the udder (mastitis)**

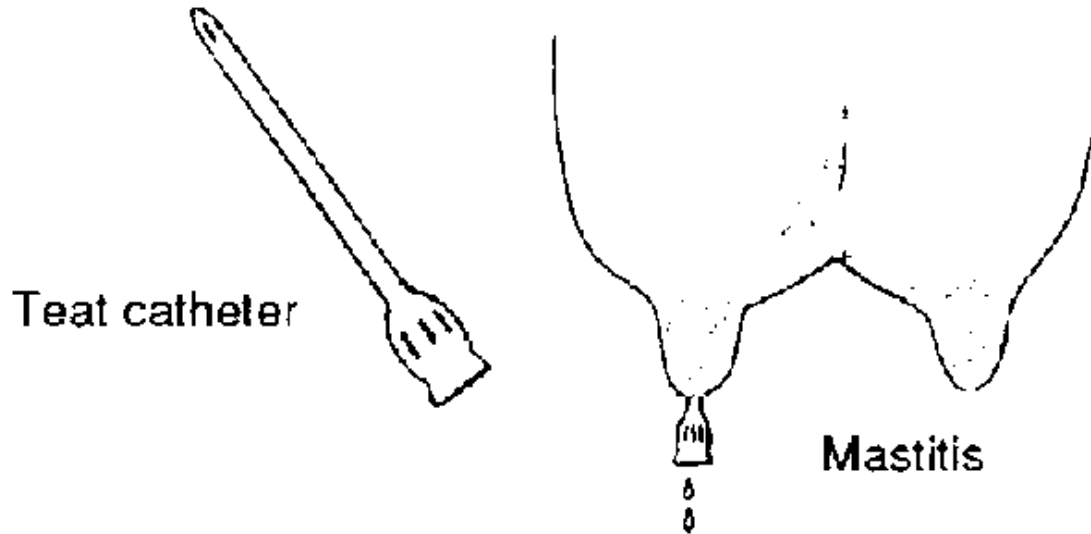

**To treat mastitis the udder should be bathed with warm water. The bad milk in the udder should then be removed using a clean teat catheter or by hand milking. This is carried out at least twice a day until the udder returns to normal.**

**A treatment which is now preferred is to bathe the affected quarter with cold water and then milk out the quarter. The udder is then dried and massaged. This is repeated morning and night**

**until the udder returns to normal. If the infection is severe this treatment is repeated every 2 to 3 hours.**

**If the infection persists antibiotic in a tube (see R19 Annex 1) should be squeezed into the teat canal following each milking. You can give an injection of antibiotic (see R6 Annex 1) in cases of severe mastitis.**

***Ask for veterinary advice if mastitis is a continual or spreading problem in your community.***

## **Ways of using milk**

**The milk of cattle, goats, sheep and buffalo are different but all contain fat, protein, vitamins and minerals and are of great value as food for humans. Milk can be used to make cream, butter, ghee, yoghurt and cheeses as well as other forms of food.**

**Although milk is a good food it can carry diseases. It can also become infected with germs from the person who milked the animal or by dirt from the animal. Whoever drinks the milk can then become infected.**

**If milk is kept it will become sour and unfit to drink. If milk has to be stored for use during the day it should be boiled every 4 to 5 hours and kept in a clean covered container. If milk is to be kept overnight it should be boiled and put in its clean, covered container in a cool place out of reach of cats, rodents and insects. It should be boiled again in the morning before it is used.**

**To prevent disease being spread by milk:**

- **Only use milk from healthy animals.**
- **Wash and dry the animal's udder before milking, thoroughly wash the hands before milking.**
- **Always throw away the first squeezes of milk from the udder as this may contain germs.**
- **Boil the milk before drinking it.**
- **Store milk in clean vessels in which water has been boiled or which have been washed out with hot water.**

## **Unit 23: Feed and water for ruminants**

***In order to get the most out of livestock you must always give animals enough good feed and clean water.***

***Good feed is high in nutrients and provides everything that the body needs in order for the animal to grow and reproduce.***

### **Learning objectives**

**After studying this unit you will know:**

- 1 What nutrients animals need in their feed.**
- 2 What is a daily ration.**
- 3 What are roughage and concentrate feeds.**
- 4 Feed for the dry season.**
- 5 Fodder trees.**

### **What an animal needs in its feed**

**All animals and humans need the nutrients called carbohydrates, proteins, fats, vitamins and minerals in their feed in order to stay**

**healthy, have energy, grow and reproduce.**

**Carbohydrates such as sugar and starch are burned in the body to give energy. Fats are broken down in the body to give carbohydrates and water. Animals and humans store carbohydrates as fat in the body.**

**Protein forms the building blocks of the body. It is needed to produce the muscles.**

**Minerals such as copper and calcium are needed to form the bones, brain, nerves and blood. Plants take in minerals from the soil. Vitamins are essential for a healthy body and all plants contain several vitamins.**

**If animals do not get enough of any nutrient they will become less productive and may die from a condition called a deficiency disease.**

**If an animal does not get enough fat, protein or carbohydrate in its feed it cannot grow properly, loses weight, milk production**



**drops and production of young is affected. Lack of minerals results in such problems as failing to come into heat, poor bone growth and loss of hair or wool. While lack of essential vitamins can cause problems such as blindness and swollen joints.**

## **Types of feed**

**A good, rich feed contains more energy than a poor feed and a cow gets as much energy from 1 kg of sorghum, barley or corn as it does from 6 kg of grass. Some feeds are very poor and of little use to the animal. For example old straw contains little energy, most of it cannot be digested and passes out of the animal as dung.**

- Roughage is bulky and low in energy-giving carbohydrates. Examples of such feeds are grasses, maize stalks and sweet potato tops.**
- Concentrates are feeds which are rich in proteins and carbohydrates, e.g. grain crops.**

**The large stomach of the ruminant with its four compartments means that it can live mainly on roughage. Animals with single stomachs need more concentrates than ruminants.**

## **Rations**

**A daily ration is the amount of feed an animal needs every day. A good ration will contain all of the nutrients. Some nutrients are found in large amounts in some plants:**

<b>Nutrient</b>	<b>Plants</b>
<b>Carbohydrate</b>	<b>maize, sorghum, wheat, oats, rice, grass</b>
<b>Protein</b>	<b>lucerne (alfalfa), clovers, beans, grass</b>
<b>Fats</b>	<b>cotton seed, sunflower seeds, grass, groundnuts</b>

**An example of a good ration which can be given to animals not on pasture is 3 parts of maize, part sunflowers and 1 part unshelled groundnuts. The ration is fed at the rate of 2 - 3% of body weight each day.**

**Green growing grass contains all the nutrients but in the dry season grass contains little protein and vitamins. It is necessary to give additional feeds at this time in order to prevent weight loss, maintain high milk production, growth and reproduction. It may also become necessary to give minerals to the animal.**

### **Feed for the dry season**

**In the dry season grass becomes scarce and is low in nutrients. When grass is plentiful in the wet growing season you can cut grass and store it until it is needed in the dry season. The grass can be kept as hay or silage.**

**Hay is dried grasses. The best hay is prepared from young grasses. Cut the grass and leave it to dry in the sun for several days turning it over to make sure it is completely dry when it can be stored until needed. Do not try to make hay in the rainy season.**

**Silage is grass or other plants which are cut while green and stored without air. To make silage you will need an airtight**

**container or pit to store it in.**

## Silo

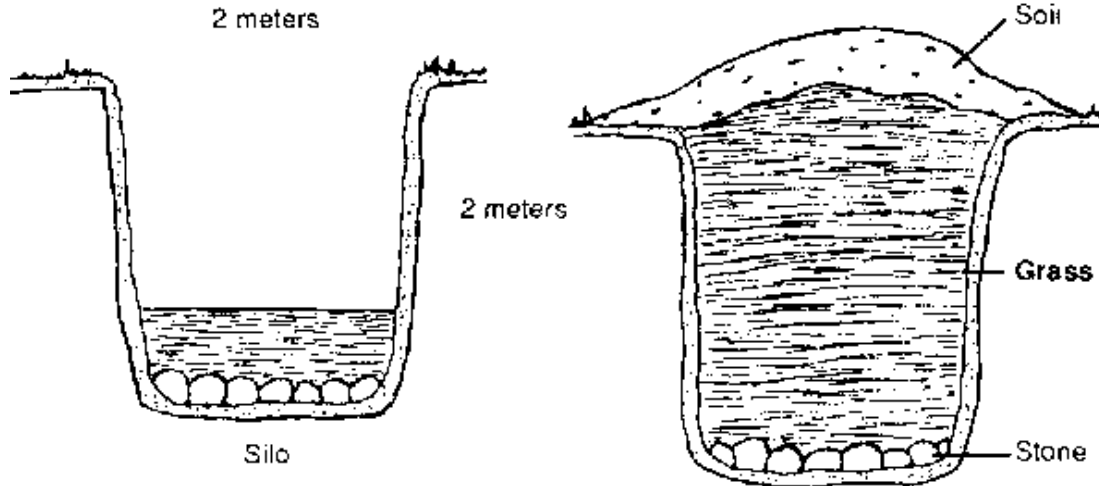

**Dig a pit 2 metres deep and 1.5 to 2.0 metres wide. Put a base of large stones in the bottom of the silo. Cut grass and fill the silo with it, stamping down the grass with your feet. The silo must be filled in 1 to 2 days.**

**When filled cover the top of the silo with a sheet of plastic or stones and a covering of soil in order to keep out water and air. Leave the silage for a few months before using it. The quality of the silage will depend on the plants used. Silage keeps well and animals like it.**

## **Fodder trees**

**In some communities people traditionally cut tree branches to feed their animals. We now know that some trees are better than others for feed. The best trees are leguminous trees (Leucaena).**

**These trees can be grown in rows 4 m apart. Other crops can be grown between the rows of trees (alley farming). The leaves and branches of the trees can be cut through the year and used as animal feed.**

**Using these trees for feed is beneficial because:**

- **The leaves of the trees provide good feed for animals all through the year.**

- **The rotting leaves provide a mineral rich mulch (natural fertiliser) for other crops.**
- **The trees provide fuel wood, timber and shelter from the wind.**
- **The trees stop soil erosion and improve the fertility of the soil.**

***Ask your agriculture officer or veterinarian about using fodder trees.***

## **Supplementary feeds**

**Supplementary feeds are given when the grass is poor and dry or when an animal is pregnant, giving milk or is a working animal.**

**The best supplementary feed is cake. The cheapest of which is the waste material from the processing of coconuts, groundnuts, cottonseed and palm oil. You can use whatever is available locally.**

## **Water**

**Animals need plenty of fresh clean water every day. Always give water before feeding animals and allow them to drink at least three times a day. Ruminants on pastures can be watered every 2 - 3 days. Do not allow animals to stand in the water at the drinking place. This can cause disease to spread. Water needs will vary according to the feed they eat and the weather.**

**A pinch of salt can be added to the drinking water to provide minerals.**

### **Remember**

**Take care not to spread disease through feed and water. Keep water and feed troughs clean and do not allow animals to eat old or musty feed.**

**Change feeds slowly. Take special care when introducing fresh green feed so that bloat is avoided.**

**New methods of feeding animals have been developed and are used in many countries:**

- **Feeding urea-treated straw. Straw is a low nutrient feed for ruminants but if it is wetted with urea and covered for a week it becomes more nutritious.**
- **Molasses-urea-mineral blocks. Blocks made of molasses, mineral salts and urea are a good supplement for ruminants which lick the block and take in the nutrients.**

**You should talk to the people in your community to discover what they feed their animals. Your local veterinarian or extension worker can advise you on the best types of feed that you can get locally and how they can be used for the livestock in your community. You could encourage your community to make hay or silage for use in the dry season.**

## **Unit 24: Grazing management**

***Managing the grazing of pastures by herds and flocks will:***

- ***Prevent overgrazing of pasture and loss of soil through***



***erosion***

- ***Ensure maximum production of animal feed from the land***
- ***Help in the control of internal and external parasites***

**Learning objectives**

**After studying this unit you should know:**

- 1 How to manage pastures.**
- 2 What is meant by pasture rotation.**
- 3 The value of managing pastures.**

**Pasture management**

**Pasture management is the control of pasture grazing by all animals. Pasture should be grazed lightly enough to keep the mature grass growth down but not so much that it is cropped to the ground. If some grasses are not touched by the grazing animals, pull them up before they flower and produce seeds. The livestock should then be moved off the pasture and it is rested to allow the growth of fresh grass. Bushes and trees which goats**

**like to graze will also produce fresh growth.**

**It may be necessary to move herds some distance to find new grazing. Buffalo and cattle can travel up to 3 km while goats and sheep travel up to 5 km from watering points in search of fresh grazing.**

### **Pasture rotation**

**Pasture can be fenced or hedged to make protected enclosures. This allows animals to be confined to an area while the neighbouring pasture is rested. In this way land can be grazed for 1 to 2 weeks and then rested for several weeks to allow grass to regrow. This is pasture rotation.**

### **Pasture rotation**

First week



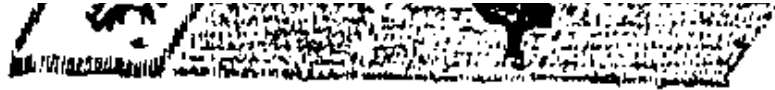

Second week



Third week





## Why manage the grazing of pastures?

When the grazing of pastures by livestock is controlled it brings several benefits:

- Herding animals allows them to be watched and any problems such as bloat will be quickly noticed.
- By preventing animals from overgrazing pasture the fertile top soil will be held in place by the plants and their roots. It will not become eroded and the soil is not washed into streams and irrigation channels causing problems for farmers.

- **Pasture rotation allows fresh growth of feed plants for the animals. It allows pasture to be left long enough for grasses to produce good roots and seed.**
- **Fencing areas to keep animals out allows the growing of special feed crops which can later be cut and fed to the animals.**
- **Pasture rotation helps in the control of both internal and external parasites. Do not always keep young animals on the pasture near the water supplies. It is here that large numbers of parasite eggs build up.**
- **Pasture rotation increases the fertility of the soil through the animals depositing dung.**

**Encourage the people in your community to look after the local environment and keep it free from objects that can be a danger to grazing animals and people.**

**Remember that the grazing ruminant can eat many things as it**

**grazes:**

- **Wire and nails can pass through the wall of the rumen into the heart and kill. They can also injure the feet.**
- **Plastic bags can choke an animal and block the stomach.**
- **Tin cans and glass can cut the mouth, feet and legs.**

**Unit 25: Cattle plague (rinderpest) and foot and mouth disease**

***Ruminants, especially young animals, can suffer from a variety of diseases.***

***Rinderpest (cattle plague) is highly infectious and can kill cattle and buffalo.***

***Foot and mouth disease is very common in many countries. It affects cattle, sheep, buffalo and goats.***

***These two diseases are very important. Rinderpest occurs in***

***Asia, the Middle East and Africa while foot and mouth disease occurs all over the world except in Australia, New Zealand, North America and now Western Europe. Ask your veterinary service for more information about these diseases and ask your community to help in any vaccination campaign that the veterinary service may organise.***

## **Learning objectives**

**After studying this unit you should be able to:**

- 1 Recognise when cattle and buffalo are suffering from rinderpest.**
- 2 Recognise foot and mouth disease in ruminants.**

## **Cattle plague (rinderpest)**

- The signs of rinderpest infection in cattle and buffalo are:**
- First stage is a high fever (40.5°C to 41.5°C).**

- **Red patches appear on the vagina or scrotum followed by patches on the lips, nostrils and around the eyes.**
- **In buffalo the first sign of the disease is a discharge from the eye.**
- **The patches develop pus (yellowish matter) in them.**
- **Frothy saliva comes from the mouth.**
- **The animal suffers from constipation (can not pass dung) followed by diarrhoea. The important sign is the bad smell of the dung.**
- **After a few days the animal dies**

**Rinderpest is a highly infectious disease and can kill many animals especially cattle and buffalo. The disease is mainly spread through the drinking water which has been infected by the dung of sick animals but it can also spread by direct contact and in the breath. The disease affects wild animals and pigs. Deaths**



**of wild pigs can be a sign that rinderpest is present in the area.**

***Ask your veterinarian for more information about the disease.  
Help the veterinary service if they have a campaign against  
rinderpest. Vaccinate your cattle against rinderpest and ear mark  
them so that they can be identified.***

## **Foot and mouth disease**

**The signs of infection with foot and mouth disease are:**

- **First stage is a high temperature.**
- **Small blisters (bags of skin filled with fluid) appear in the mouth and on the tongue, between the claws, around the hoof and on the teats.**
- **The blister will break and the skin over it is lost to give reddish patches.**
- **Saliva will be produced but the animal has difficulty in eating.**

- The hoof may come off and the animal will be lame.

**There are a few diseases which have similar signs to foot and mouth disease. Ask your veterinarian for advice about the signs of the disease.**

---



---

## Chapter 4: The pig

---

[Unit 26: Handling and restraining pigs](#)

[Unit 27: Teeth clipping in young pigs](#)

[Unit 28: Internal parasites of pigs](#)

[Unit 29: Skin infections of pigs](#)

[Unit 30: Heat \(oestrus\) in the sow](#)

[Unit 31: Pregnancy and farrowing \(giving birth\)](#)

[Unit 32: Care of the sow and piglet](#)

[Unit 33: Castrating piglets](#)

[Unit 34: Feeding pigs](#)

[Unit 35: Housing for pigs](#)

[Unit 36: Ear tagging or notching \(identification\)](#)

---

## Unit 26: Handling and restraining pigs

*By the time they are weaned young pigs are too big to be easily lifted. Older pigs can be moved from place to place using pig boards.*

*Pigs are very clever and quick to learn. They can be dangerous.*

### Learning objectives

After studying this unit you should be able to:

- 1 Safely handle young pigs.
- 2 Handle older pigs.
- 3 Restrain the pig.

## **Handling the young pig**

**Piglets can be caught from behind and held by grasping the hind leg just above the hock. The small piglet can then be lifted by placing the other hand under the chest and lifting the animal. When holding the piglet always support its weight against you. By the time the piglet is weaned it will be too heavy to lift.**

## **Handling the young pig**

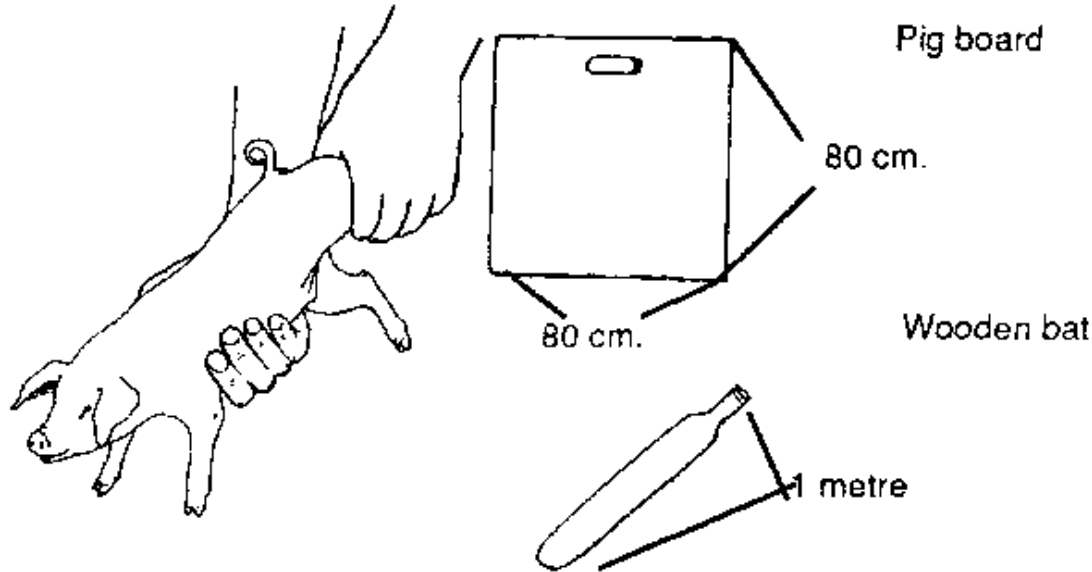

## Handling the older pig

**Pigs will naturally head for a gap (or opening) when you approach them or try to catch them. You can use this habit to make the pig go where you want it to. If two pig boards (wooden boards 0.8m square) are placed either side of the pig's head it will move forward in the direction the handlers want it to go. As the animal gets older it can be trained to move under the control of one**

handler who uses a board and a wooden bat about 1 m long.

***The handler always keeps the pig board between himself and the pig. If several people try to drive a pig it can turn and charge between them.***

## Restraining a pig

You can restrain a pig by holding it with ropes against a wall or fence. Large pigs can be easily restrained with a rope or wire loop around the snout.

## [Restraining a pig](#)

## Unit 27: Teeth clipping in young pigs

***The teeth of the young pig are clipped as soon as possible after birth. The piglet is born with 8 teeth.***

***If the teeth are not clipped the sow's (mother) udder may be injured by the suckling piglets. Removal of the teeth also prevents the young pigs injuring themselves while fighting or***

***playing.***

## **Learning objectives**

**After studying this unit you should be able to:**

- 1 Understand why the teeth of young pigs are clipped.**
- 2 Carry out teeth clipping on the piglet as soon as possible after its birth.**
- 3 Handle the sow and her young with as little stress as possible to both.**

## **Why are the teeth of piglets clipped?**

**Piglets bite the sow (mother) in their fight to get hold of one of her teats and suckle. The pain caused by this disturbs the sow causing her to get up and prevents her young from feeding. The cuts to the sow's udder also allow germs to infect the udder. In their fight to grasp the teat and suckle piglets will also bite and injure one another. The simple practice of clipping the teeth as soon as possible after birth prevents these problems.**

## **When to clip the teeth**

**The piglet's teeth should be cut as soon as possible after its birth. The teeth can be cut when the pig is only 15 minutes old. The sow and her young should be separated for as short a time as possible. In order to clip the teeth you will need either a pair of tooth clippers, or pliers or forceps.**

**You will need someone to help you separate the sow and her young. You will also need a box containing bedding and a clean empty pen.**

## **Clipping the teeth**

- If the sow is not tied up separate her from her young and place her in another pen. Take care as the sow with a litter can be dangerous.**
- Corner the young pigs and keep them together or place them in a box.**
- Hold the head and press the corner of the piglet's**



**mouth so that the jaws open.**

- **Place the clippers on either side of one pair of teeth making sure that the tongue is not in the way. Tilt the head so that the pieces of the teeth will fall out of the mouth.**
- **Cut the teeth as close as possible to the gums.**
- **Clean the clippers before using them on another piglet. Operate on the rest of the litter and when you have finished put the piglets back with their mother immediately. Keep young piglets warm.**

### **Clipping the teeth**

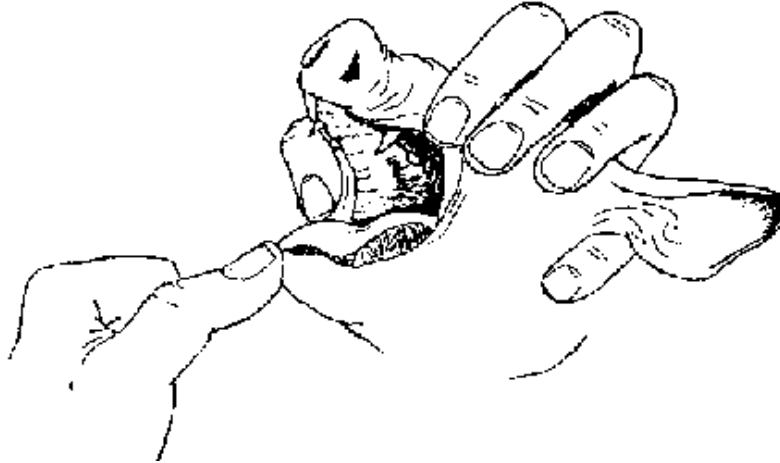

## Unit 28: Internal parasites of pigs

***Pigs can be infected with a number of different roundworms. These can result in poor weight gain in adults. In young pigs infection with roundworms can cause diarrhoea, weight loss, lung problems and death.***

***Worms from pigs can cause disease in human.***

### Learning objectives

## **After studying this unit you should know:**

- 1 The problems caused by roundworms in pigs.**
- 2 How to treat and control roundworm infections of the pig.**
- 3 Problems caused in human by pig parasites.**

### **Roundworm infections of the pig**

**Pigs can be infected with a number of different roundworms. People who keep pigs can notice large roundworms, 25 - 40 cm long in the animals' dung. In pigs 2 to 5 months old the worms cause diarrhoea, weight loss and lung problems. The young worm lives in the liver and lungs before passing into the intestine. The damage to the lungs can allow germs to attack and cause coughing and lung infections. The young pig can die.**

**The worm in the liver of young and adult pigs causes white spots (milk spot) to develop. Such a liver should not be eaten by humans.**

### **Treatment and control of roundworms**

**Infected pigs are easily treated by dosing with a suitable treatment, e.g. piperazine (see R13 Annex 1). The pregnant sow should be treated before giving birth or she will pass on infection to her litter. One female worm will produce a million eggs a day which pass out in the dung. These eggs infect new hosts and can stay in the ground or the pigsty for up to 5 years.**

**The pigsty, shelter or pen should be cleaned out and the walls and floor treated with caustic soda which is left for 2 - 3 days before washing it off. If infected pigs have been kept out in a field the land should be ploughed and used for a crop, or as grazing for other animals, before pigs are put back on it.**

### **Problems caused by pig parasites in humans**

**Pigs can be infected with a parasitic worm called Trichinella. The adult worm lives in the intestine while young worms are found in the muscles (meat). It does not appear to be a problem to the pig. Any animal which eats the pig meat can be infected with the worm.**

**Pigs can be infected with Trichinella from eating rats which have the infection. Pigs will also be infected from contaminated meat so all meat fed to the animals (e.g. in swill) should be thoroughly cooked. Thorough cooking of pork will also kill the worm. If humans eat undercooked pig meat from an animal infected with this parasite they will become infected too.**

**If a pig is left to wander around it may eat plants contaminated with human faeces. In this way the pig meat can become infected with a tapeworm from humans. If the meat of that pig is not properly cooked people who eat it can become infected with the pork tapeworm.**

***Do not allow pigs to wander around free.***

## **Unit 29: Skin infections of pigs**

***Pigs can be infected with lice and mange mites. Mange can cause wounds which can become infected and can result in the hide becoming of no use for leather production. Humans can also catch the mange infection.***

***The pig can also be attacked by ticks.***

***Pigs can suffer from erysipelas (diamond skin disease) which causes diamond shaped discolouration of the skin.***

## **Learning objectives**

**After studying this unit you should be able to:**

- 1 Recognise mange and lice infections of pigs.**
- 2 Know how to control and treat mange and lice infections of the pig.**
- 3 Recognise erysipelas in pigs.**
- 4 Know how to control and treat tick infections of pigs.**

## **Mange in pigs**

**Mange is caused by infection with mites (see Unit 16) and results in thickening and crusting of the skin. The activity of the mites burrowing into the skin makes the pig scratch and the wounds caused can become infected with germs. Mange occurs around the head, ears, legs and tail but will spread over the body if not**

**treated.**

**Mange is controlled by spraying, dipping or painting the infected areas with a suitable preparation (see R15 Annex 1). The pen and shelter should also be thoroughly cleaned out and washed down. Treatment should be repeated after 2 weeks.**

**After working with mangey pigs wash your hands thoroughly and wash clothing too.**

**If you have a mange problem in your community which you cannot stop you will need to ask for veterinary advice. To identify the mite causing the problem the veterinarian will need skin scrapings from infected animals. Identifying the mite will allow him to decide what treatment you should use.**

**Lice and tick infections**

**Pigs can suffer from infection with dark coloured lice which can be seen on the animal's body. The lice feed on the skin and irritate the pig which will scratch and can cause wounds which**

**become infected. Treatment involves spraying with coumaphos (see R15 Annex 1) and cleaning the areas where the animals are kept.**

**Pigs can be attacked by some ticks which take blood. The ticks may carry other infections to the animals. Treatment can be carried out by spraying with a suitable compound (see R15 Annex 1) or by removing the ticks by hand or by touching them with kerosene or a lighted cigarette. Affected pens should be thoroughly cleaned.**

### **Erysipelas (diamond skin disease)**

**Erysipelas or diamond skin disease of pigs can kill the animals. This is an infection of the pig's body which produces recognisable discolouration on the pig's body. These are reddish diamond-shaped areas on the skin or the animal may have a purplish colour to the head and ears. Pigs with erysipelas have a high temperature and do not feed; they squeal if touched. The animal can die from an acute infection or in chronic cases the animal survives but suffers from swollen joints and lameness.**



**Erysipelas is treated by using the antibiotic penicillin (see R 7 Annex 1). Animals can be vaccinated against the disease.**

### **Unit 30: Heat (oestrus) in the sow**

*The female pig (sow) is ready to breed (reaches puberty) at 5 months of age and will show signs of being in heat. Some slow growing types and animals which are underfed will be older when they reach puberty.*

*The sow will come into heat every 3 weeks throughout the year if she is not mated.*

#### **Learning objectives**

**After studying this unit you should know:**

- 1 When a female pig is ready for breeding.**
- 2 How often the pig comes into heat.**
- 3 The signs of heat in the pig.**
- 4 How to make the pig come into heat.**

## **When is the sow ready for breeding?**

**Most breeds of pig reach puberty at 5 months of age but some, e.g. the Chinese pig, come into heat for the first time at 3 months of age when they have enough good feed and water.**

**The pig should not be used for breeding when she comes into heat for the first time. It is wiser to allow her to grow for another month before using her for breeding. She will then be better able to carry and suckle a good litter of young. Only sows with 14 teats should be used for breeding so that all her litter can feed.**

**If the pig is not mated she will come into heat every 21 days, providing she has enough feed and water.**

### **Signs of heat**

**The female pig coming into heat is restless and may not eat. The vulva becomes pink and swollen. When the pig is pressed hard with the hands on either side of her back she will stand still, showing she is ready to accept the male.**

## Signs of heat

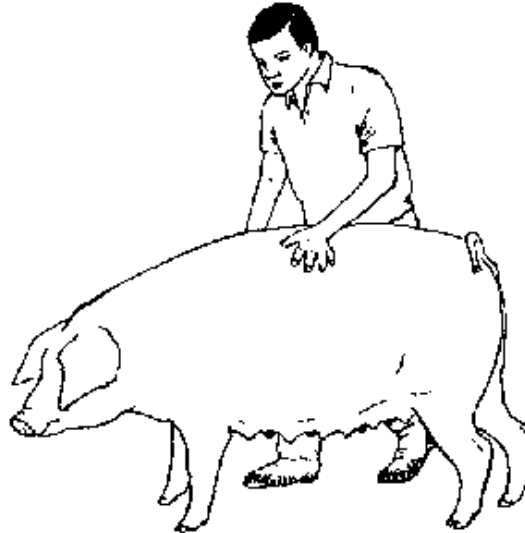

**The sow will be in heat for 8 to 36 hours.**

**How to bring the sow into heat**

**Healthy, well fed sows can be brought into heat so that breeding can be controlled.**

**Putting a sow which is in heat in with those which are not in heat will make some of the latter come into heat. A better method is to pen sows next to a boar so that they can see and smell him. The sows will come into heat especially if the boar is old and smelly.**

***Remember that failure to come into heat can be the result of poor or too little feed or a health problem in the sow.***

### **Unit 31: Pregnancy and farrowing (giving birth)**

***Pregnancy lasts for 3 months 3 weeks and 3 days.***

***A well fed sow will produce at least 10 piglets (litter) from each pregnancy and may have 2 litters each year.***

#### **Learning objectives**

**After studying this unit you should be able to:**

- 1 Care for the pregnant sow.**
- 2 Recognise when the sow is about to farrow (give birth).**
- 3 Recognise normal farrowing.**

## **4 Recognise when the sow has problems and be able to assist.**

### **Care of the pregnant sow**

**If the sow shows no sign of being in heat 3 weeks after mating she is pregnant. The pregnancy will last about 3 months 3 weeks and 3 days. During the pregnancy the sow will need plenty of feed high in nutrients and will especially need more feed towards the end of the pregnancy. She should be given some feed high in nutrients e.g. grain and greenstuffs every day. Giving the sow access to clean soil or grass with roots from land where no pigs have been kept will allow her to get the minerals she needs.**

**Give the sow plenty of clean bedding when birth is close.**

### **Signs that the pig is ready to farrow**

**The sow becomes restless and starts to make a nest within 24 hours of giving birth. The teat will produce milk when gently squeezed.**

**Blood stained fluid may be passed from the vagina 1 to 2 hours before birth begins and if small greenish pellets appear the first piglet will appear within an hour.**

***Gently rubbing the udder will make the sow relax and lie on her side in the position to give birth.***

## **Normal farrowing**

**Farrowing is a natural process and the sow will usually need no help. Once the first piglet is born the others, and the afterbirth, will quickly follow. Farrowing should be completed within 2 to 3 hours. The navel cord will break (you do not need to cut it) and the piglet will immediately search for a teat and milk. If the navel bleeds, tie it tightly with a clean string or cord.**

## **When and how to help in farrowing**

**If the sow shows all the signs of farrowing but she has not produced a piglet and is pawing with a hind leg, or if 45 minutes has passed since the first piglet appeared and there is no sign of the second you will have to help the sow.**

- **Wash your hands and arms with warm water and soap and scrub under your fingernails.**
- **Wash the region of the vulva.**
- **Make your hands soapy or put olive or sunflower oil on your hands.**
- **Put your hand into the vagina and feel for the piglet or matter causing the blockage and try to remove it.**

**Clear the piglet's mouth and nose of mucous and if it is not breathing you can slap it to encourage it to breath. Gently rub the piglet dry and put its mouth on a teat.**

### **Unit 32: Care of the sow and piglet**

***A healthy well-fed sow will be able to rear at least 20 piglets each year.***

***If the sow has too many piglets to feed, or if a sow dies, the***

***young can be fostered or hand reared.*****Learning objectives****After studying this unit you should:**

- 1 Know if the sow is a good mother.**
- 2 Judge if the piglets are feeding well.**
- 3 Know how to foster piglets.**
- 4 Know how to hand-rear piglets.**

**How good a mother is the sow?**

**A sow should have at least fourteen teats which should be long and thin enough for the piglet to grasp. Each piglet suckles from its own teat feeding every hour. The first born and stronger piglets use the teats nearest the sow's head which produce most milk. As a sow gets older and has more litters the teats can become large making it difficult for the piglet to suckle. Sometimes the back teats do not produce much milk. A sow may be unable to feed all her young and is no longer fit for breeding.**



**A sow can suffer from mastitis which may develop as a result of damage to the teats caused by the piglets teeth. Clipping the teeth of the piglet (see Unit 27) prevents cuts to the teats.**

**Are the young feeding well?**

**Not all of the piglets will grow at the same rate, some will be born smaller than the others. They fight for feed and the smaller piglets will grow at a slower rate and even die. You can expect to see a difference in weight gain and growth between the members of any litter, but if all of the piglets do not grow well and there are no obvious signs of disease you should suspect poor milk production by the mother. This is often the case with old sows.**

**It can become necessary to foster the piglets, i.e. put them with a different sow for feeding.**

**Fostering piglets**

**It is essential for all piglets to take colostrum from the mother. They will take the first feed within 1 hour of being born.**

**If a sow dies during farrowing her litter can be fostered to another. The orphans should be mixed in with the sow's own litter so that she will accept them. However the foster mother will not be able to feed both litters at the same time and it will be necessary to use several foster mothers to feed the orphans.**

### **Hand rearing piglets**

**A sow may die and there is no foster mother available. The litter can be reared by hand feeding. To hand rear a litter the following will be needed:**

- **Feeding bottles and teats (nipples) which are thoroughly cleaned between each feeding.**
- **A clean dry box containing clean bedding for the newborn piglets which can be kept in a warm place.**
- **Regular feeds must be given at intervals of 1 to 2 hours.**
- **Cow's colostrum is the best substitute for the sow's**

**colostrum and after 3 to 4 days the piglets can be given milk.**

### **Unit 33: Castrating piglets**

***Castration, or the removal of the testicles, is carried out on the male pig which is not needed for breeding.***

***If the blood vessel to the testicle is cut straight through, or pulled heavy bleeding can occur. Bleeding is reduced by scraping the twisted blood vessel with a knife until it is cut through.***

***Castrated animals are quieter and easy to handle.***

***The castrated animal is fatter and produces meat which does not have a strong smell.***

#### **Learning objectives**

**After studying this unit you should know:**

- 1 Why male pigs are castrated.**
- 2 When is castration carried out.**
- 3 How to restrain pigs for castration.**
- 4 How to castrate animals.**

## **Why are pigs castrated?**

**Male pigs (boars) can fight causing injury to one another. Castrated pigs are quieter and easier to handle. Castrating the pig makes it put on more fat and the meat does not have a strong piggy smell. Young pigs should be castrated at 2 to 3 weeks of age.**

## **Restraining the pig for castration**

**You will need someone to hold the piglet for castration. The pig should be held by the hind legs with its head down and its body should be firmly held between the handler's knees.**

## **Castration cuts**

Castration cuts

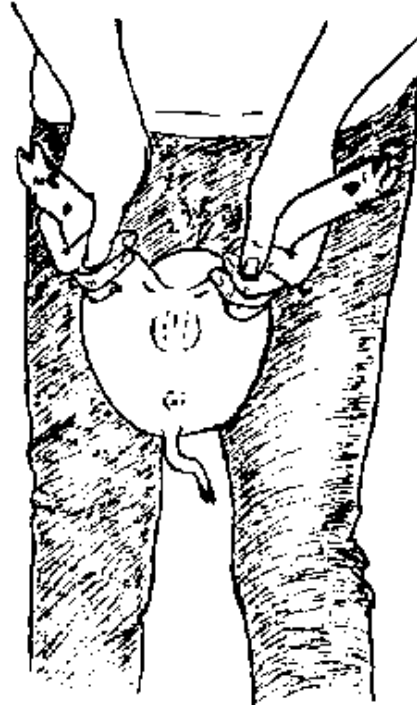

## Castrating the pig

**You will need a very sharp, clean knife, scalpel or razor blade.  
Remove the sow from the litter and if possible put her where she**

**cannot see or hear them.**

- **Clean the scrotum with warm water and soap and dry it.**
- **Move the testicle into the scrotum with your finger and then firmly grip the scrotum below the testicle between your thumb and index finger.**
- **Make a cut 1 - 2 cm long in the bottom of the scrotum. The testicle should pop out through the cut.**
- **Pull the testicle out of the scrotum and cut through the white cord *leaving the red blood vessel uncut.***
- **Pull the testicle out slightly further and twist it around several times before *cutting the twisted blood vessel by scraping up and down with the knife.* This helps to reduce bleeding. *Do not pull to break the vessel.***
- **Do not put your fingers in the scrotum. Apply either**

**tincture of iodine, gentian violet, Dettol or an antibiotic powder (see R5 Annex 1) or a sulpha powder to the castration wound. Remove the second testicle in the same way.**

**Put the piglets and their mother on clean bedding. Watch piglets for signs of infection in the wound for the next week. Infected castration wounds swell, piglets do not want to walk or are lame. See Unit 73 for treatment.**

### **Unit 34: Feeding pigs**

***The pig is omnivorous and can eat meat and plants. The digestive system of the pig can also use bulky feeds containing a lot of roughage.***

***Pigs must have plenty of clean, fresh water every day.***

### **Learning objectives**

**After studying this unit you should know:**

- 1 What types of feed to give pigs.**
- 2 How often you will need to feed pigs.**
- 3 How and when to wean piglets.**

## **The types of feed to give to pigs**

**Pigs will eat anything. They will eat grass and all types of plants. They can be kept in a well fenced field where they will eat all of the plants and grass there. The pig not only eats the green parts of plants but will also dig into the ground and eat all the roots. A pig with a nose ring cannot root up plants.**

**The pig's eating habit can be used by man. If a pig is put in a field it will clear it, plough it and fertilise it.**

**Pig's will grow and get fat more quickly if they are fed concentrate feed. Grain which has been well ground into meal is a good feed. Waste vegetables and household scraps can also be given to pigs. Household scraps, especially those containing meat, must be well boiled (pig swill) before being given to the pig.**

**The pig must always be able to drink fresh clean water. A sow**



**with young will need 20 - 30 litres of water a day.**

## **The types of feed to give to pigs**

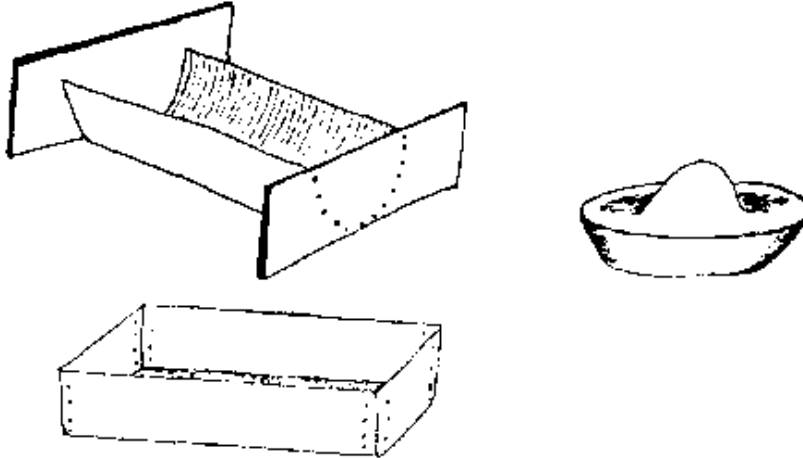

**How often will a pig need feeding?**

**Pigs can be kept in a sty when they will need to be fed twice a day with one feed in the morning and one in the evening. Pigs in the field can be offered meal once a day or given extra feed, e.g. vegetable waste or swill, when it is available.**

## Weaning

**Piglets show an interest in solid feed when they are 1 or 2 weeks old. They can be offered a handful of cereal, sugar or powdered milk to start with. Piglets will take milk from the mother until they are about 7 weeks old. They will gradually take less milk and eat more solid feed until they are weaned. Piglets in the field will naturally start to eat solid feed but it must be offered to those that are housed. The young animals need to be gradually given new feed to avoid digestive problems.**

***Remember that a pig should rush to eat its feed. Lack of interest in feed is a sign of ill health and you will need to look at the animal to determine the cause of health problems.***

### Unit 35: Housing for pigs

***Pigs can be kept in a field where there is a shelter or they can be kept in a pig sty.***

***Pigs should not be allowed to wander about free. There will be***

***no control over what they eat or where they go and disease will spread.***

## **Learning objectives**

**After studying this unit you should know:**

- 1 How to keep pigs in a field.**
- 2 The types of housing (buildings and pens) for pigs.**
- 3 Housing piglets.**

## **Keeping pigs in a field**

**Wild pigs live amongst bushes and the roots of trees. When pigs are kept with access to a warm, low area to lie and sleep in, as they would in the wild, the pigs do better.**

**Pigs can be kept in a field where they can feed on grasses and plants. If pigs are kept this way, the field must be surrounded by either a strong fence or a wall. Pigs will push their way out of a field if the fence is not strong enough. The animals are given shelters called pig arks to sleep in. These can be made of wood**

**or metal sheets and should contain bedding. The arks can be moved to fresh ground when necessary.**

### **Keeping pigs in a field**

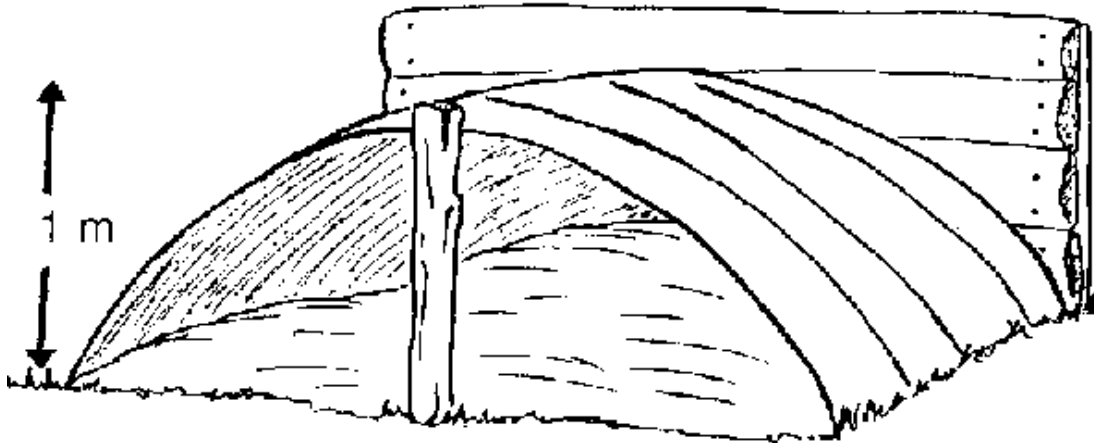

### **Housing and pens for pigs**

**Pigs can be kept alone or in small groups in a pig sty, a concrete or solid floored pen with a low shelter.**

**When building a sty you should choose an area which is never flooded in the rainy season. It should not be too near to houses so that smells and flies are a nuisance. The floor should be concrete and sloping away from the sleeping area so that urine flows out and away. The concrete floor should be laid on a good foundation and will need to be 5 - 6 cm thick. If the concrete is too thin and cracks, the pigs will soon start to dig it up. An earthen floor cannot be kept clean and will lead to problems with parasites and other diseases. The walls of the sty need to be fairly smooth so that they can be kept clean. Cracks in the walls will allow dirt and germs to accumulate.**

**The animals should be given plenty of bedding in the shelter. Pigs will always dung away from their sleeping and feeding areas. The dung can be removed every day allowing the pen to be kept clean and avoiding the build up of waste and smells.**

### **Housing and pens for pigs**

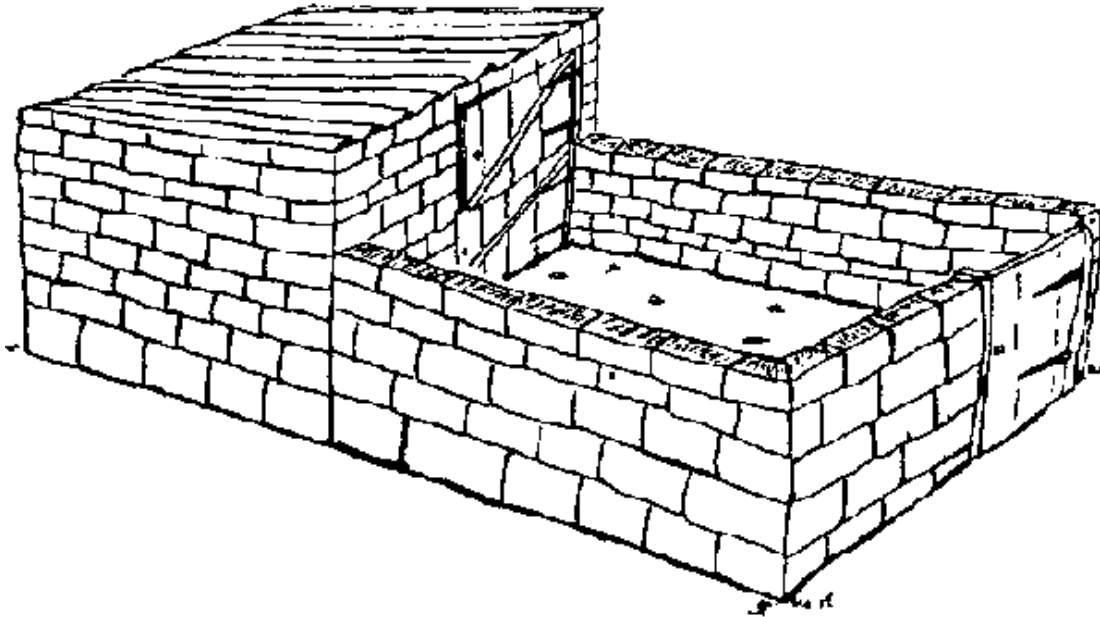

## Housing for piglets

**Breeding sows and their litters can be kept in sties or using the open field system. Plenty of bedding should be given to help keep the young animals warm and it must be changed frequently. If a litter is raised in a sty, the sty should be thoroughly cleaned and**

**scrubbed out after the litter has been weaned and moved elsewhere. If a litter is raised in the field, the shelter should be moved to a new site for the next litter to avoid disease problems, especially from parasitic worms, developing.**

**Whatever the housing method used piglets should have access to a warm area which the sow cannot reach. This is called a creep and piglets can be given feed here and can lie down without the risk of the mother lying on top of them. The sow is prevented from entering the creep by placing a temporary wall of boards or strong rails across part of the shelter. The bottom rail is about 30 cm from the ground allowing the small piglets to pass under it.**

### **Housing for piglets**

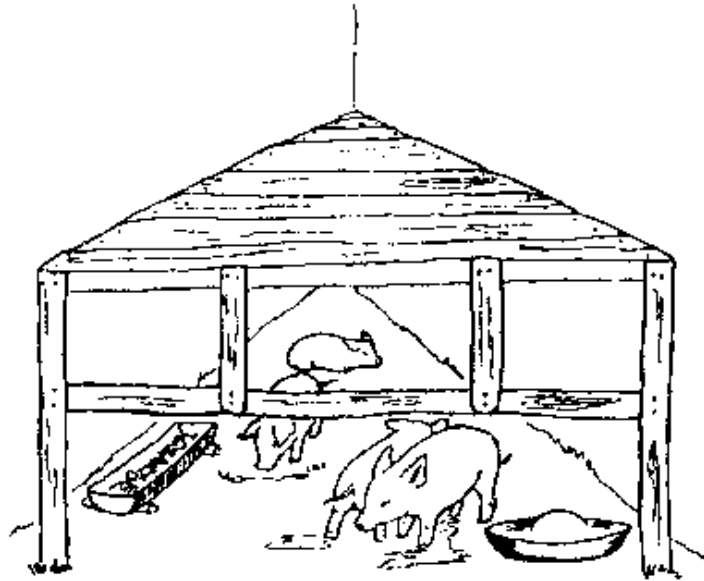

***Do not allow pigs to wander free around the community. This results in the spread of disease among the animals and also between them and people.***

### **Unit 36: Ear tagging or notching (identification)**

***Ear tagging or notching allows you to identify your pigs by***



***sight. Notching is easy to do and costs nothing. You can identify up to 121 pigs in this way.***

***This method can be used to identify other animals, e.g. sheep and goats.***

## **Learning objectives**

**After studying this unit you should know:**

- 1 Why do we identify animals.**
- 2 How to notch the ear.**
- 3 Reading the number of the pig.**

## **Why we need to identify animals**

**If you have a few pigs or other animals, identifying them is no problem. You will be able to identify them by sight and may well have given them a name. You will need some way to identify a large number of animals especially if you are going to keep records (see Annex 5). There are many ways to identify animals**

**including numbered collars, tattoos, and plastic tags. Notching the ear is easy and is the cheapest way.**

## **Notching the ear**

**A V-shaped notch can be cut out of the edge of the ear using a pair of clean scissors. Make the notch a few centimetres deep so in future you will be able to read it from a distance.**

**The notches on the left ear are for single numbers and on the right ear the notches are for tens.**

## **Notching the ear**

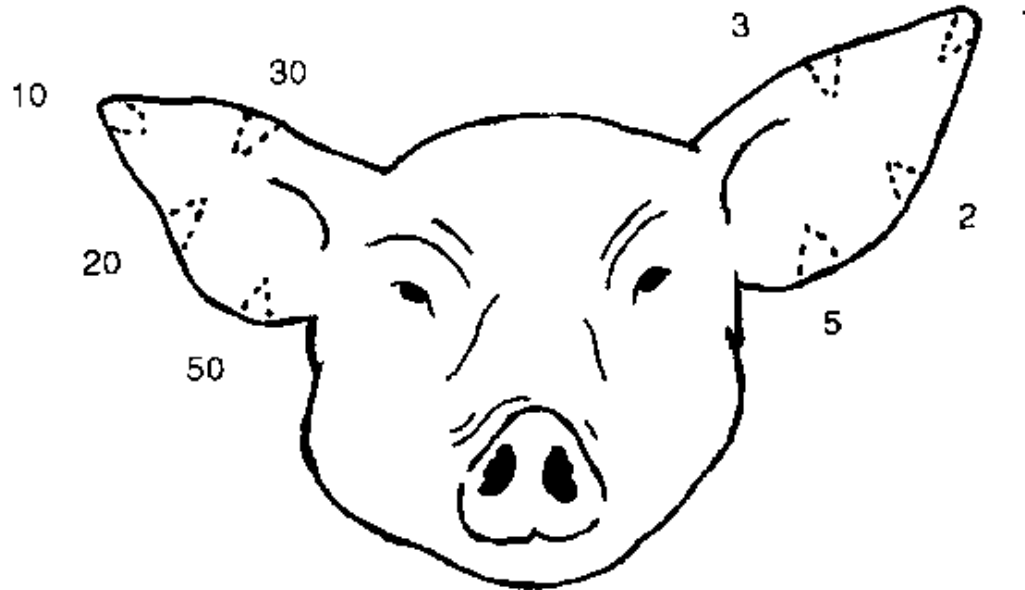

## Recording the number of the pig

Look at the notches on the right and the left ears then add up the number on each ear to give the number of the animal.

## Recording the number of the pig



Number 8

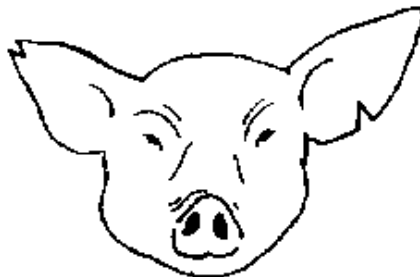

Number 15

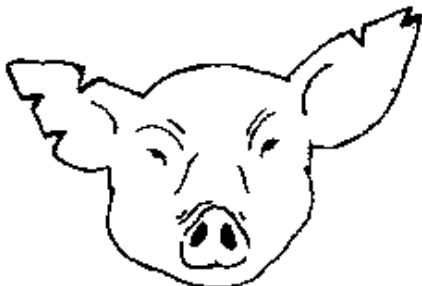

Number 104

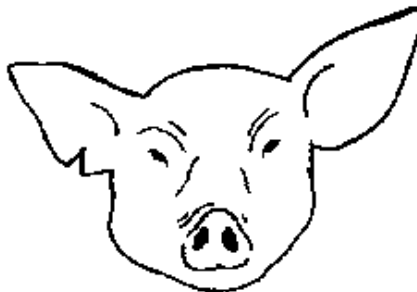

Number 50





---

## **Chapter 5: Horses, donkeys and mules**

---

[Unit 37: How to restrain horses, donkeys and mules](#)

[Unit 38: How to age horses](#)

[Unit 39: Hoof \(foot\) care, shoeing and lameness](#)

[Unit 40: Colic](#)

[Unit 41: Internal parasites of equines](#)

[Unit 42: Skin and coat disorders of equines](#)

[Unit 43: Heat \(oestrus\), mating and pregnancy](#)

[Unit 44: Foaling and caring for the young](#)

[Unit 45: Stabling and grazing](#)

[Unit 46: Feed and water for equines](#)

[Unit 47: Grooming and tackle \(tack\)](#)

[Unit 48: African horse sickness](#)

---

**Unit 37: How to restrain horses, donkeys and mules**

***Horses, donkeys and mules are called equines.***

***Equines can kick and bite and there are a number of different ways to control these animals in order to examine, treat or shoe them.***

## **Learning objectives**

**After studying this unit you should know:**

- 1 What are equines.**
- 2 How to use the twitch.**
- 3 How to restrain equines.**
- 4 Hobbling equines.**

## **Equine animals**

**Equines are the members of the horse family and have single hooved feet. The equines are the horse, donkey, mule and hinny. The father of the hinny is a horse and the mother is a donkey.**

## **Using the twitch**

**The twitch is a simple tool used to control equine animals. You can make one from a strong, thick stick in one end of which is a hole through which is passed a loop of rope 30 cm. long. The twitch is put on the muzzle.**

**Put your hand through the loop and hold the animal's muzzle. Slip the rope over your hand and twist the stick to tighten the rope around the muzzle.**

**Do not put the twitch on the animal's ear as this is very painful.**

### **Using the twitch**



Twitch

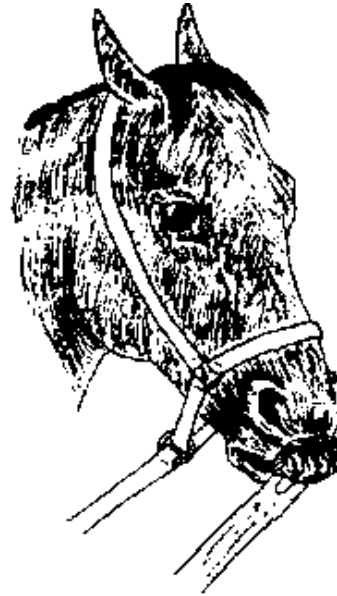

## Hobbling animals

**A set of hobbles consists of four straps each of which has a metal ring attached to it. A rope is passed through the rings. Pulling the rope will make the animal fall and when it is down the head should be held down to keep it down. An animal is hobbled in order for it to be examined or castrated.**



**Hobbling the back legs only is done to the mare when she is mated to a valuable stallion. The hobbles prevent her from injuring the stallion.**

### **Hobbling animals**

**Lifting one leg to control the animal**

**Holding one leg up will stop the animal moving or kicking. This will make it easier to examine, check its teeth or take its temperature. It will be necessary to restrain the animal's head. It may be necessary to use the twitch on the muzzle to fully restrain it.**

**Holding front leg while temperature is taken**

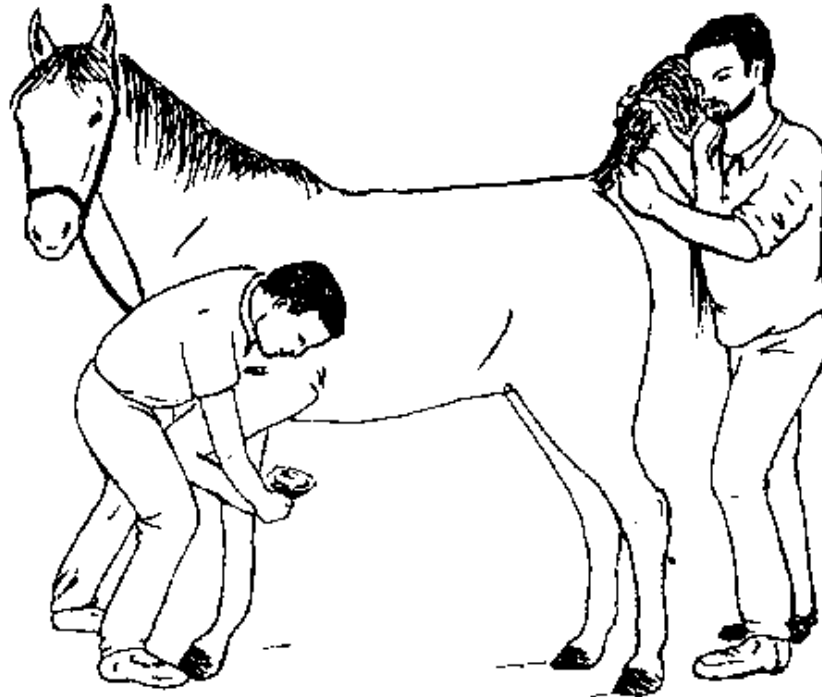

### **Covering the animal's head (blindfolding)**

**Putting a blanket, coat or sack over both the eyes will calm an animal and make it easier to restrain.**

## **Opening the mouth**

**Hold one ear and slip your other hand between the incisors and the cheek teeth and pull the tongue out. The tongue of the horse, unlike that of the cow, is long. This is useful when checking the cheek teeth in ageing the animal, rasping teeth or administering drenches.**

## **Opening the mouth**

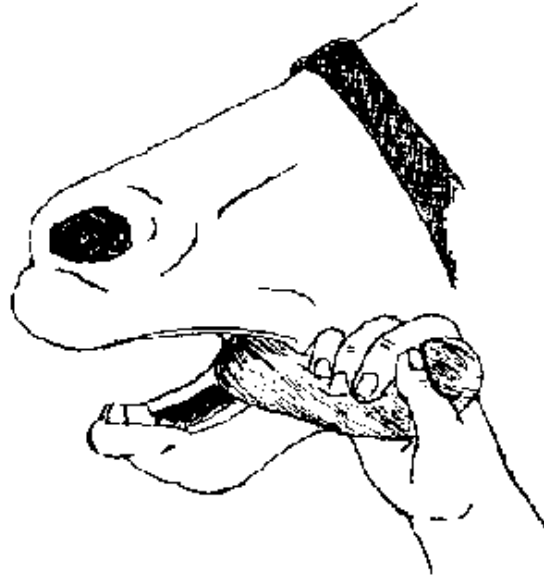

## Unit 38: How to age horses

***Horses can be aged with some accuracy up to the age of 5 years by looking at the front and cheek teeth.***

***If the feet and the teeth are looked after, a horse can live and work for many years.***

## **Learning objectives**

**After studying this unit you should be able to:**

- 1 Recognise the temporary (milk) teeth of the horse.**
- 2 Recognise the permanent teeth.**
- 3 Recognise the Galvayne groove.**
- 4 Know how to age horses.**
- 5 Know about teeth problems in horses.**

### **The temporary (milk) teeth of the horse**

**The foal at birth has only two front teeth in each jaw and as the foal grows other temporary (milk) teeth are emerge. There are 24 temporary teeth which are smaller than the permanent teeth.**

**Upper jaw: 6 front teeth, 3 cheek teeth on each side**

**Lower jaw: 6 front teeth, 3 cheek teeth on each side**

### **Permanent teeth**

**When you need to look at the animal's teeth you can open the**

**lips to look at the front teeth, but to see the cheek teeth you will need to pull out the tongue (see Unit 36).**

**There are 36 to 40 permanent teeth in the horse:**

- **Front 6 teeth in each jaw  
teeth:**
- **Cheek 6 teeth on each side of the jaw  
teeth:**
- **Sharp, long teeth situated in the gap between the cheek  
Canine and front teeth. There are 4 teeth, one on each side of  
(dog) the upper and lower jaw.  
teeth:**

**The canine teeth start to emerge when the horse is 4 years old.  
The teeth are large in the male but in the female are very small or  
absent.**

**How to age horses**

**Teeth on the upper and lower jaws are similar.**

- (1) Birth: 2 temporary front teeth**
- (2) One month old: 4 front temporary teeth, 3 temporary cheek teeth on each side**
- (3) Six to nine months: 6 front temporary teeth**
- (4) One year old: 4 cheek teeth present**
- (5) One and a half years: 5 cheek teeth**
- (6) Two and a half years: 2 permanent front teeth replace 2 temporary teeth**
- (7) Three and a half years: 4 permanent front teeth showing**
- (8) Four years old: 4 canines show and 6 cheek teeth**
- (9) Four and a half years: 6 permanent front teeth**

**See the diagram below.**

## **Diagram**

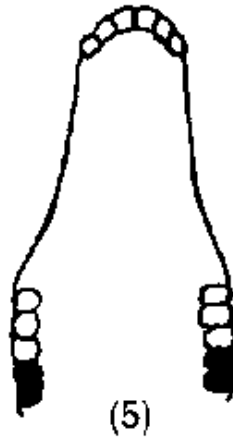
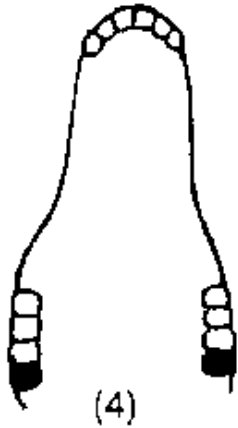
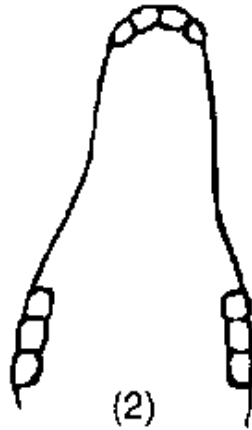



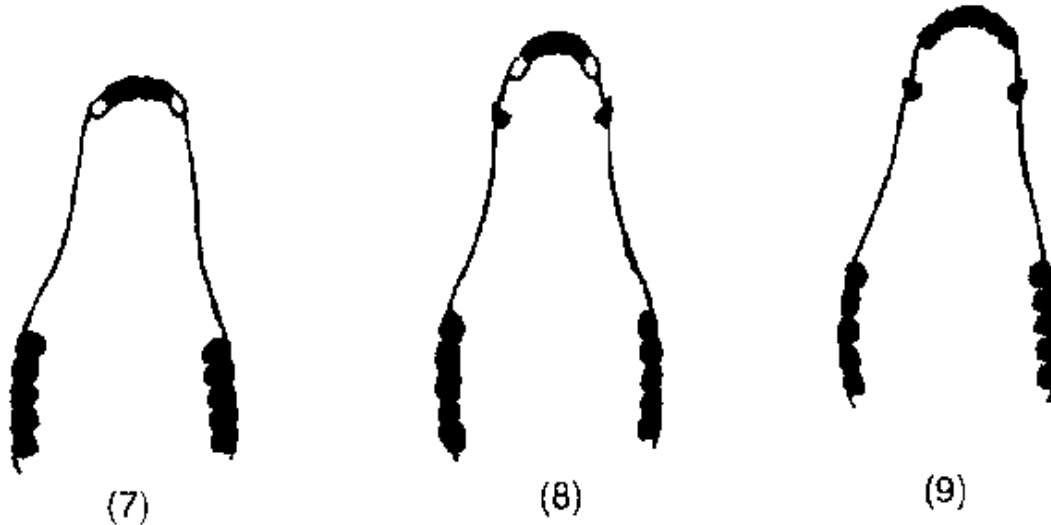

○ Temporary (milk) teeth

● Permanent teeth

**From 6 to 25 years of age the point of contact of the front teeth and the surface wear of the teeth will point to the age of the animal.**

**[How to age horses](#)**

## **The Galvayne groove**

**This is another way to tell the age of the horse from 10 to 30 years. It appears at 10 years of age as a little canal on the top of the corner front teeth. By 15 years of age it has reached the middle of the tooth and at 20 years it has reached the bottom. It then starts to fill up and by 30 years of age the groove has disappeared.**

## **The Galvayne groove**

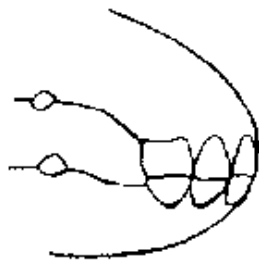

7 years

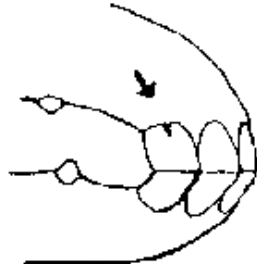

10 years

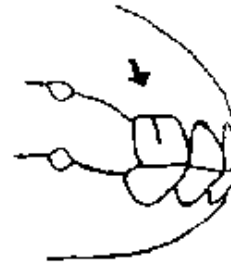

15 years

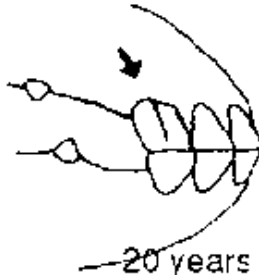

20 years

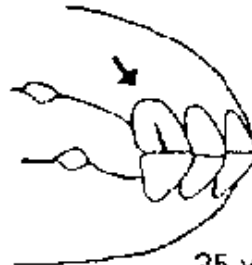

25 years

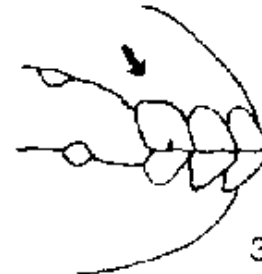

30 years

## Teeth problems

**As equines grind their food the edges of the teeth become sharp and can damage the tongue or the inside of the cheek. If you find that an animal has difficulty eating, open its mouth by taking out**

**the tongue (see Unit 36) and check the cheek teeth with your finger. You may need a veterinarian to rasp the teeth.**

***You should check the teeth several times a year. Remember that teeth and hooves in good condition are essential in equines.***

### **Unit 39: Hoof (foot) care, shoeing and lameness**

***The equine foot is a very sensitive area and must be examined frequently.***

***A well fed, strong animal is no good if a hoof is bad.***

#### **Learning objective**

**After studying this unit you should know:**

- 1 The structure of the equine foot.**
- 2 How to keep the foot healthy.**
- 3 The importance of shoeing animals.**
- 4 How to recognise lameness in equines.**
- 5 How to treat the lame animal.**

## **The equine hoof**

**The foot of equine animals consists of three bones, the long pastern, short pastern and the pedal bone. What we see of the hoof is the wall of the hoof and underneath is the sole.**

## **The equine hoof**

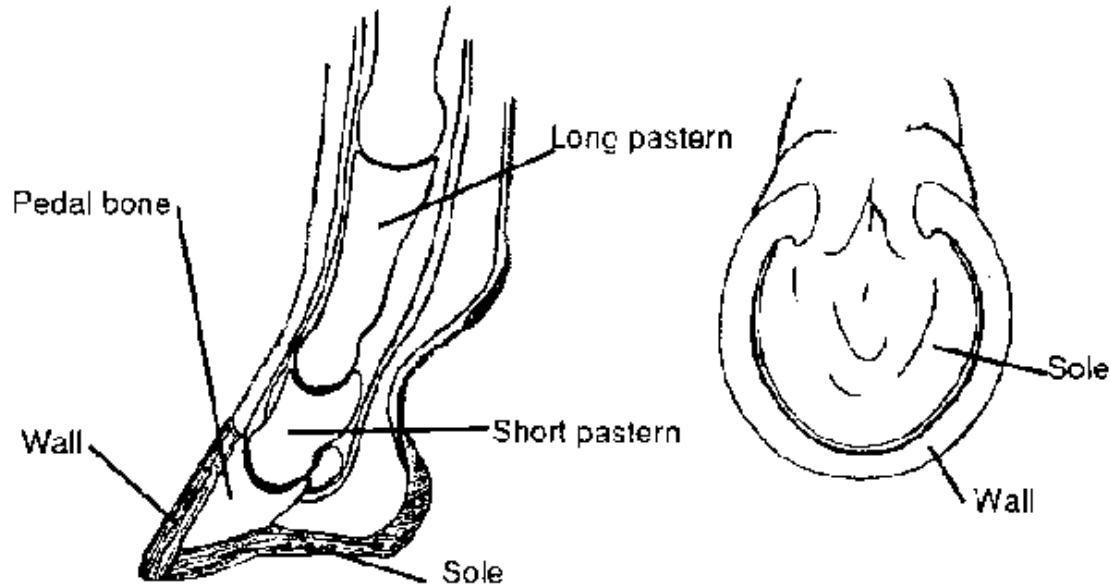

## Keeping the hoof healthy

**The animal should be made accustomed to having its feet picked up. Clean the sole of the hoof from mud and dung. If these materials are not removed the moisture they contain may cause infection of the sole of the hoof.**

**Dress (cover) the wall of the hoof regularly with grease or oil to keep it moist. This will prevent the hoof from cracking.**

## **The importance of shoeing**

**The wall of the hoof grows like the nail of your finger. It is worn away as the animal walks. When animals walk or work on hard surfaces such as concrete, tar or mountain roads the hoof may be worn away more quickly than it grows. In this case shoeing the animal protects the hoof. If an animal is shod the shoes should be removed every 6 weeks so that the extra growth in the hoof can be removed.**

**Shoeing and oiling the hoof stops it from splitting. Contact the farrier (horseshoe maker) every time you want to shoe the animals or if the animal develops lameness because of a problem with the shoes.**

## **Lameness**

**Lameness is an abnormal walk and is caused by injury or disease.**

**Remember that it can be difficult to discover where the lameness is and what is causing it. To identify the lame leg you will need to:**

- **Halter the animal and ask someone to lead the animal around for you.**
- **To check the front legs ask your helper to trot (faster than walk) the animal towards you when a lame animal will be seen to nod the head as it trots. The head is raised as the lame leg touches the ground.**
- **To check the back leg have the animal trotted away from you. Watch the back of the animal and you will see it rise as the lame leg hits the ground.**
- **Examine the lame leg for any heat, swelling or pain.**
- **Lameness is usually caused by a problem with the foot.**

## **Lameness**



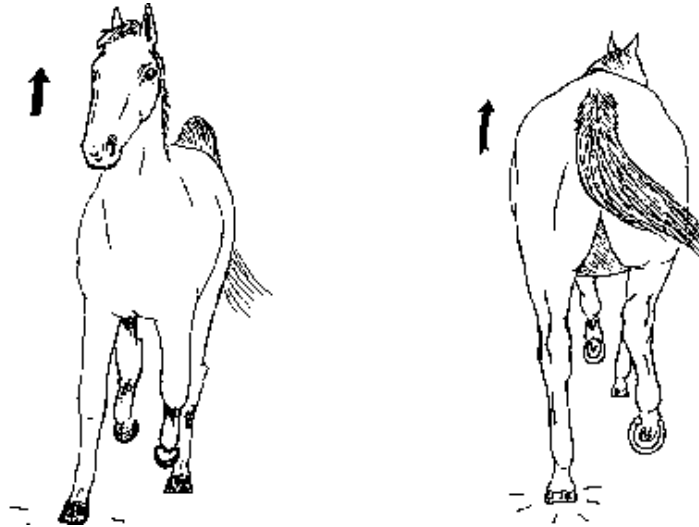

## Treating lame animals

**You should ask for veterinary advice but you may be able to do something about the problem.**

- **Sometimes lameness is caused by the sole of the hoof becoming infected. The sole is painful and pus (yellow secretion) is formed. Clean the wound and apply tincture of iodine. Leave the animal to rest and do not work it.**

- **A crack in the wall of the hoof can cause lameness and is cured by oiling the hoof and correct shoeing.**
- **The bottom of the foot can be infected and becomes wet, black and smelly. This is called thrush and is seen in animals kept in wet conditions. Cut away the infected material and put formalin or tincture of iodine on the area (see 1: 3 A Annex 1)**

## **Unit 40: Colic**

***Colic is a pain in the belly and may be continuous or comes and goes.***

***There are many causes of colic including parasitic worms, bad feed, and drinking water too soon after working.***

### **Learning objectives**

**After studying this unit you should be able to:**

- 1 To know when an animal has colic.**
- 2 Know what causes colic.**
- 3 Know how to prevent colic.**
- 4 Know how to treat colic.**

## **How to recognise colic**

**Colic is the name given to abdominal pain and is common in equines. The signs of colic are:**

- The animal kicks at its belly.**
- It repeatedly lies down and then gets up, rolls about or it sits up on its back legs like a dog.**
- The animal sweats.**
- The pain can be continuous or it comes and goes.**

**If an animal is showing the above signs, take its temperature (see Unit 4) and its pulse.**

**In horses if the temperature is over 39.5°C and the pulse is over 60 per minute the condition is very serious and you will need to**

**find a veterinarian immediately.**

**The causes of colic**

**There are a number of different causes of colic:**

- **Parasitic worms in the digestive system.**
- **The animal's teeth are bad and cannot chew food properly.**
- **The animal has been grazing on sandy ground, sand causes colic.**
- **The animal has eaten too much grain.**
- **Drinking water when it is hot and tired after working.**

**Preventing colic**

**You can prevent colic by:**

- **Treat the animal regularly to get rid of gut parasites (see Unit 41).**
- **Check the animal's teeth, ask your veterinarian to rasp**

**sharp teeth.**

- **Do not give water to tired, hot and sweating animals.**
- **Do not give too much grain to the animal.**

**How to treat a horse with colic**

**Walk the animal around for a while and do not allow it to eat any feed. Give it a drench of magnesium sulphate or vegetable oil and water (see R22, Annex 1). Ask for veterinary assistance.**

#### **Unit 41: Internal parasites of equines**

***Equines suffer from a number of parasitic worms in the gut which may sometimes be found in the dung. Maggots of the bot fly live in the stomach and are also found in the dung.***

***The parasites cause loss of weight and bad condition. In foals they may cause diarrhoea. The worm infections often cause colic and can result in the death of the animal.***

***Lungworms which infect the lungs cause respiratory problems***

***and are common in donkeys which pass on the infection to the horse.***

## **Learning objectives**

**After studying this unit you should know:**

- 1 The parasitic worms which infect equines.**
- 2 The problems caused by the parasitic worms in equines.**
- 3 How to treat worm infections.**
- 4 How to control worm infections in equines.**
- 5 Horse bots (bot fly) and their importance.**

## **Parasitic worms of equines**

**A number of worms infect the gut of equines. The largest is a roundworm which can be over 30 cm long and produces millions of eggs which survive on the pasture for a long time.**

**Redworms (up to 3 cm long) are roundworms also found in the intestine. These live for a time in the liver and the main arteries**

**which take blood to the gut. They finally pass into the gut where they feed on the wall of the intestine.**

**Often seen in the dung are white worms up to 15 cm. long which have long thin tails. These are the whipworms which live in the intestine and lay their eggs around the anus of the host where they develop before falling onto the ground.**

**Lungworms infect the lungs and are common in donkeys which can have large numbers of worms. Eggs are coughed up and swallowed to pass out in the dung**

### **Parasitic worms of equines**

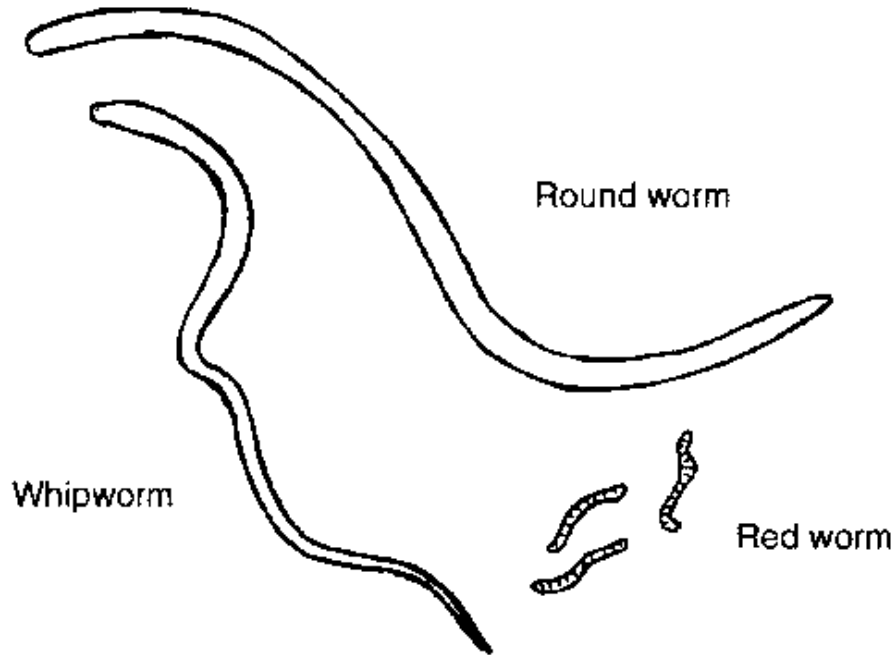

## Problems resulting from infections with worms

**The large roundworms are not often found in animals over 4 years old. They are a problem in the foal and can cause weight loss, dull coat, poor condition and can cause colic by blocking**



**the gut. Young worms moving through the lung cause coughing and the damage to the lung can allow other infections to develop.**

**The redworms suck blood and badly damage the wall of the gut. The worms passing through the blood vessels can cause severe damage and result in weakening of the vessels and blockage. The worms can cause colic which is often fatal if not treated.**

**Whipworms cause irritation of the anal region making the animal restless and causing it to rub its tail against a wall or post. Infected animals do not feed properly and can lose condition.**

**Lungworms can be present in large numbers in the donkey without it showing any signs. However the donkey can pass on the infection to the horse which suffers from lung problems, coughing and discharge from the nostrils. Heavy infections kill horses.**

**How to treat infected animals**

**Adult worms can be killed by giving a drench containing fenbendazole. Haloxon can be used to treat worms in the gut (see**

## **R12 Annex 1).**

### **Preventing infection with worms**

**There are several ways of reducing the chance of animals becoming infected:**

- **Removal of dung from small pastures reduces the number of eggs contaminating the pasture.**
- **If other grazing animals are kept, allow them to graze pasture following the horses to reduce the contamination of the pasture. Ruminants are not infected by horse parasites.**
- **Stables should be kept clean and dung removed daily to a dung heap. Any worm eggs in the dung will be killed by the heat that is formed when the dung rots. Turning the dung heap over every one or two weeks will ensure that the heat reaches all the eggs and kills them.**
- **Regular treatment with anthelmintics (every 3 months if**

**possible) reduces the worm problem.**

## **Horse bots**

**Bot flies lay their eggs on the hairs of the lower legs, shoulders and around the mouth. The maggots hatch and are taken into the mouth as the animal licks. They burrow into the gut and develop in the stomach where the red coloured maggots can live for up to one year. The maggots pass out in the dung and burrow into the soil where they change into the adult fly.**

**The adult flies annoy the host and the maggots damage the stomach but they are not as great a problem as the worms. Bots can be removed by giving the animal a drench containing haloxon (see R12 Annex 1).**

**Bot fly - Maggot in dung**

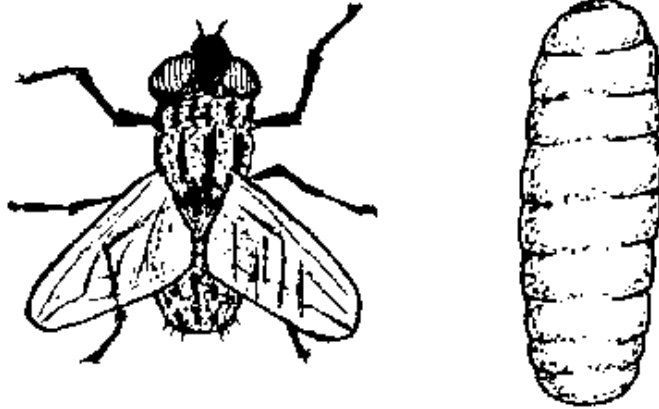

## Unit 42: Skin and coat disorders of equines

***Equines can suffer from a number of different skin and coat problems including mange, ringworm and infections caused by other germs.***

***These conditions cause severe irritation and can result in loss of condition and a reduction in the animal's ability to work.***

### Learning objectives

**After studying this unit you should be able to recognise:**

- 1 Mange on equines.**
- 2 Infections caused by lice.**
- 3 Problems caused by ticks and flies.**
- 4 Ringworm in equines.**
- 5 Rain scald, mud fever and cracked heels.**

## **Mange on equines**

**Several different mites (very small insects) can infect equines and cause mange. Various parts of the body can be affected and the conditions are known as:**

- Body mange (starts on head and neck and spreads over entire body)**
- Foot mange or itchy leg**
- Ear mange**

**Mange causes severe irritation, scabs and lesions on the skin, and loss of weight. Irritation makes the animals difficult to**

**harness and work. Body mange can cause loss of condition resulting in death.**

**The mite causing the problem can only be identified by your veterinarian examining skin scrapings under a microscope. Mange can be treated using a preparation containing gamma benzene hexachloride (see Lindane, R15 Annex 1).**

**The stable, harness and grooming equipment should be thoroughly cleaned and if possible disinfected. Remember that some mange mites can infect humans so wash thoroughly after handling infected animals.**

### **Lice infestations**

**Lice suck the blood or chew the skin. They are usually seen around the base of the tail or the mane (hair on the top of the neck). They cause irritation and hair loss but can be easily treated using gamma benzene hexachloride (see Lindane, R15 Annex 1).**

### **Ticks**

**Several types of ticks feed on equines and attack the legs, belly and ears of the animals. They suck blood and can pass on infections from one animal to another. Ticks can be removed by picking them off but sometimes the mouthparts stay in the animal and cause infections. Ticks are best removed by burning them on the back with a lighted cigarette, the tick then falls off the host.**

## **Flies**

**Equines are troubled by flies which try to feed off body moisture and blood. The animals toss the head and stamp in annoyance.**

**If the animal has an open wound flies will lay eggs close to it and the maggots which hatch will feed on the blood and meat. Any maggots found should be removed and the wounds should be properly cleansed and treated with tincture of iodine, gentian violet, Dettol or an antibiotic and an insecticidal powder or spray (see R1, 5, 8 Annex 1).**

## **Ringworm**

**Ringworm results in round whitish scabs and loss of hair. It can affect any part of the body and the lesions can become large and join together. It causes irritation and can be treated by washing the scabs with iodine solution. If the infection persists ask your veterinarian for advice and remember that ringworm can infect humans so wash thoroughly after handling animals.**

### **Cracked heels or mud fever and rain scald**

**These conditions are all caused by the same germ which infects the skin when it becomes soft from being wet for a long time. Mud fever or cracked heels occurs on the fetlocks and heels resulting in scabs and cracks in the skin which produce pus. Rain scald consists of small scabs across the back, shoulders and neck when animals have been left to stand in the rain for long periods.**

**Treatment involves removing the scabs and treating the wounds with an antiseptic (see R1 Annex 1). The affected areas should be thoroughly dried and the condition can be prevented by drying the animal's if its skin becomes wet.**



## [Cracked heels or mud fever and rain scald](#)

### Unit 43: Heat (oestrus), mating and pregnancy

***Heat (oestrus) is the period when the female show a desire for the male.***

***After a successful mating the animal becomes pregnant  
Pregnancy lasts for 11 months in the horse and 12 months in the donkey.***

***Donkeys and horses can be mated to produce hinnies or mules.***

#### Learning objectives

**After studying this unit you should know about:**

- 1 Heat and the signs of heat in equines.**
- 2 Mating in equines.**
- 3 Pregnancy.**
- 4 Care of the pregnant animal.**
- 5 Hinnies and mules.**

## **How to recognise heat in the equine**

**The donkey and horse comes into heat in spring or early summer.**

**The female horse (mare) comes into heat for the first time at about 18 months of age. However the mare should not be allowed to mate (mounted) until she is 3 years old when she will give birth at 4 years of age.**

**The female donkey (jenny) comes into heat for the first time when she is 1 year old.**

**The mare is in heat for 7 days while the donkey is in heat for 2 to 7 days. During this time the female will accept the male. It is best to mate the animals in the last 2 days of the period of heat. The signs of heat are very clear. The female frequently urinates and mucous is discharged from the vagina, she shows a strong desire to mate.**

**If mating is not successful and pregnancy does not result the**

**mare will come into heat again 14 to 16 days later while the jenny donkey comes into heat after 2 to 3 weeks.**

## **Mating**

**Choosing a good male for mating is very important. To produce a good foal you need good genetic characteristics from both parents (see Annex 4).**

**If you have valuable horses it is a good idea to apply a twitch to the mare and hobble her before bringing the stallion to her as she may otherwise kick and injure the stallion (see Unit 37).**

## **Pregnancy**

**Pregnancy lasts for 11 months in the mare. She will show an enlarged abdomen during the last 3 months of the pregnancy. The udder will develop in the last month of pregnancy. The donkey is pregnant for 12 months. Pregnant animals should not be ridden or worked in the last 3 months of pregnancy.**

## **Caring for pregnant animals**

**The pregnant animal should be fed well especially during the last 3 months as the foal may die if the mother is not well fed.**

## **Hinnies and mules**

**The father of the hinny is a horse and the mother is a donkey. The size of the hinny will depend on the size of its mother, the bigger the mother the bigger the young. The mother of a mule is a horse. Mules are powerful animals while hinnies have endurance (stamina).**

## **Unit 44: Foaling and caring for the young**

***Foaling or giving birth is a natural process and animals usually give birth without help. You should know when the mare is about to foal and keep watch on her as she may have difficulties.***

## **Learning objectives**

**After studying this unit you should know:**

- 1 What are the signs that foaling is about to happen.**
- 2 A natural foaling.**
- 3 Assisting a difficult foaling.**
- 4 Caring for the young animal.**
- 5 Castration of young males.**

## **The signs of foaling**

**Enlargement of the udder is the most reliable sign that foaling is close. A thick, clear secretion may be seen dripping from the teats and the vulva becomes swollen and loose.**

**Put the mare in a stable or shelter with plenty of clean bedding to give birth.**

## **Natural foaling**

**The mare rarely has difficulty giving birth and usually gives birth at night when no one is around.**

**The water bag breaks and the front legs appear followed by the foal's head. When the foal's shoulders are clear of the mother**

**you can clear the membrane from around the foal's nose to help it breathe. Sometimes the back legs of the foal come first but this does not present a problem.**

**The afterbirth will normally be passed within an hour after the foal has been born. You must check that it has been passed within 24 hours of birth. If it is not you will need to get veterinary help immediately.**

### **Difficulties in foaling**

**If the mare is showing signs of distress and no foal has appeared or if the foal is in an unusual position you will need to get veterinary help. You may find that:**

- **Only the foal's head has emerged from the mother.**
- **Only one leg is out.**
- **There is no sign of the foal.**

**You can try to help deliver the foal in the same way as in a difficult calving (see Unit 19). Wash your hands thoroughly with**

**soap and water, make sure your nails are short and scrub them well. Soap your hand well and insert it into the vagina to discover what is causing the problem. Try to correct the problem as for a calf or lamb and bring the foal's front feet and head into the correct position for birth.**

**If the navel cord is attached to the young it is advisable to cut it 3 cm from the body of the foal. Tie a clean string around the end of the cord and dress it with tincture of iodine, Dettol or gentian violet (see R1, Annex 1).**

### **Care of the foal**

**The foal should be on its feet within 2 hours and suckling within 4 hours. It is essential that the foal takes colostrum from its mother immediately and if the foal has difficulty in suckling you should milk the colostrum from the mare into a clean container and feed it to the foal with a bottle. If a foal has not had colostrum within 8 hours it can become infected.**

**Foals are weaned after 10 months if the mother becomes**

**pregnant again. Otherwise the young animal may be left to suckle from the mother until it is 20 months old.**

**Foals should be trained to the head collar at an early age and should become accustomed to being tied up. Use a safety knot when tying up animals (see Knots and tethers Appendix 3) so that they may be quickly released if necessary.**

### **Castration of the colt foal**

**The young male (colt) should be castrated when 2 months old. Animals up to 2 to 3 years old can also be castrated.**

**If your community has many equines it is advisable for you to purchase an emasculator which is a tool which crushes and cuts the testicular cord. Castration can be done with a knife but castration should be carried out by a veterinarian and you should ask for advice and assistance when it comes to castrating equines.**

## **Unit 45: Stabling and grazing**



***Equines, especially horses, can be kept in stables when not working.***

***They can be kept in a field with some form of shelter against bad weather conditions.***

## **Learning objectives**

**After studying this unit you should know:**

- 1 What is needed in a good stable.**
- 2 Keeping the stable clean.**
- 3 What is needed to keep animals in the field.**

## **Stables**

**Horses are often kept in stables when not working. A good stable can be made from wood, brick or concrete and should have a solid floor which slopes gently towards the door to allow urine to flow out.**

**The stable should be big enough to allow the animal to move**

**about, lie down and roll over. The stable should be 3.5m × 3m in area or larger. Small animals will need less space. A stable where the animal is free to move is called a loose box. The door of the loose box should be divided into two so that the top half can be left open during the day to allow fresh air into the stable and allow the animal to see what is going on around it.**

## **Stables**

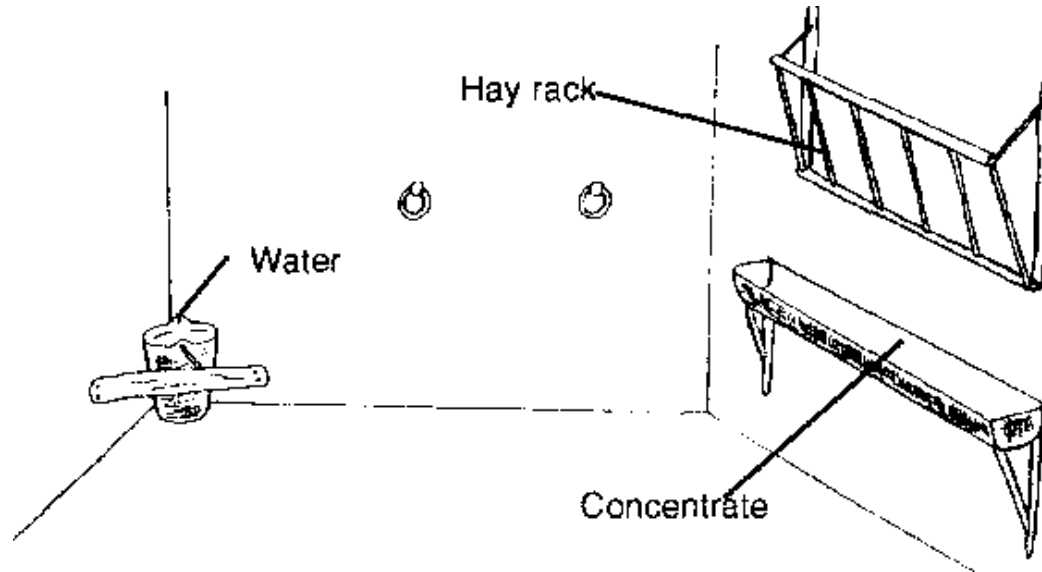

**Concentrate feeds for the stabled horse are placed in a manger (a feeding trough) which is fixed to a wall at least 60 cm above the ground. Hay is fed from a hay rack of wooden or metal bars attached to the wall at least 1 metre from the ground. Hay can also be fed from a rope net hung from a hook or ring in the wall. A metal ring should be attached to a wall to allow the animal to be tied up when it is groomed or examined. Water can be provided in**

**a strong bucket placed in a corner of the stable with a bar of wood to hold it in place.**

## Shelter

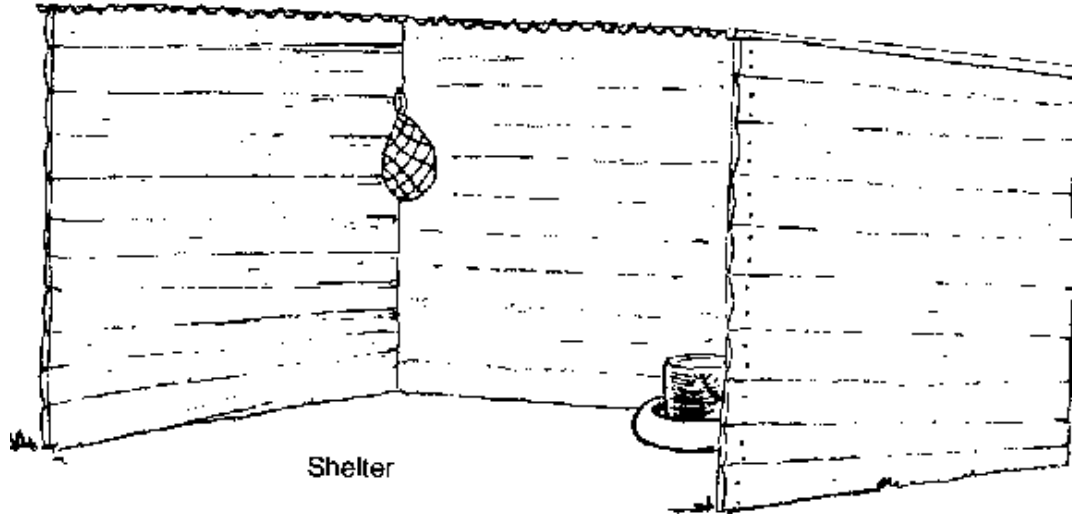

**Animals should be provided with shade and shelter. Trees provide shade and shelter can be provided by a three-sided shelter made of wood or sheeting. Animals can be fed hay or concentrates in the shelter when necessary.**

## **Keeping the stable clean**

**The manger and buckets should be emptied and cleaned every day and fresh water provided. A good bed of straw, sawdust, wood shavings or clean sand should be provided which is deep enough so that the floor of the box is not uncovered by the animal's movements.**

**Remove any soiled bedding and dung every day and take to a dung heap. Add some fresh bedding to the box. Removing the dung helps to reduce fly problems and the risk of infection from parasites. Bedding should be completely renewed when possible. The dung heap rots and produces heat which kills eggs of parasitic worms. When it is well rotted the dung can be used to fertilise land.**

## **Keeping equines out at pasture**

**Fields for equines should be well fenced. Fencing needs to be strong and can be post and rail or wire. If a wire fence is used the bottom wire needs to be at least 30 cm off the ground to prevent**

**animals getting their feet caught in it. A good strong hedge which the animals cannot push through not only acts as a barrier but will provide shelter against wind. Hedges should be made of thorn or other strong bushes planted in two parallel rows.**

### Keeping equines out at pasture

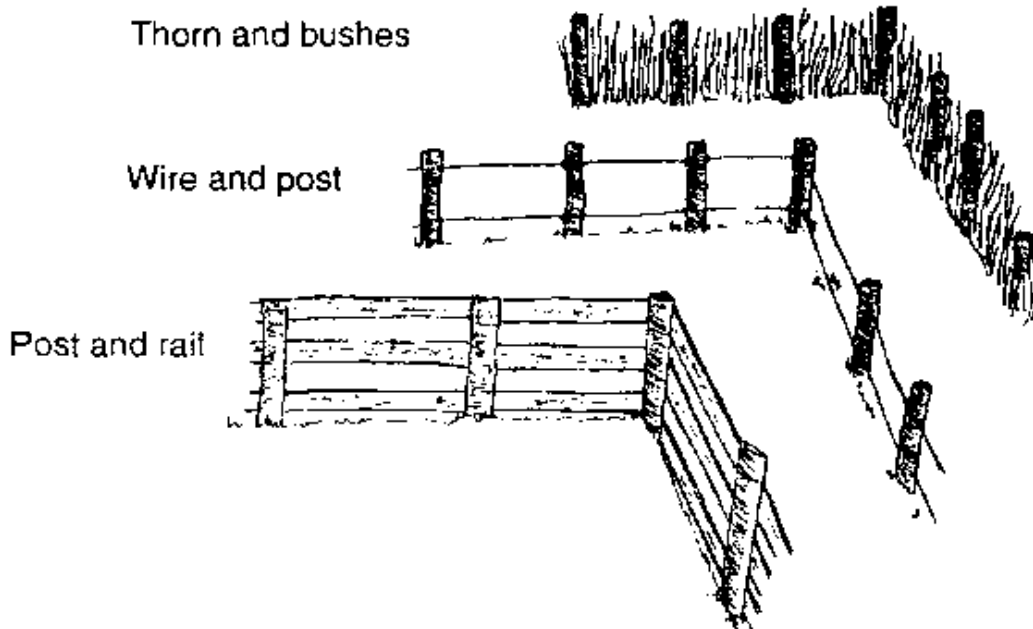

**Water will need to be provided in a trough or strong bucket which will need to be filled daily. A bucket can be placed in an old tyre to prevent it being tipped over.**

**It is a good idea to fence pasture into three areas. One third can be used while the remainder is rested or used for hay. Removing dung from the pasture will reduce contamination by worm eggs. Donkeys and horses can be tethered for grazing and moved to fresh areas every day.**

### **Unit 46: Feed and water for equines**

***Equines have a simple stomach. They eat grasses and soft plants and need grain as supplementary feed.***

#### **Learning objectives**

**After studying this unit you should know:**

- 1 The feed required by the non-working horse.**
- 2 The amount of feed needed by the working horse.**

### **3 Water requirements of equines.**

#### **Feed for the non-working equine**

**All equines are similar in their feed requirements and if they are not working or carrying young they need to be allowed to graze for at least a few hours every day on good pasture. Hay can be given to them at night.**

#### **Feed for working equines**

**The working donkey and mule will need 1 kg of concentrate feed in addition to grazing and hay. Working horses will need 2 kg of concentrate feed in addition to their grazing and hay. A heavy working horse can require 4 kg of concentrate.**

**Millet, corn, barley, rice and maize are good concentrate feeds for equines, crushed oats can be fed in small amounts. Barley is very useful and can be fed crushed or the whole grain can be fed after it has been boiled and allowed to cool. Barley makes a good feed if it is left to soak in water overnight then drained and fed with the addition of a handful of salt. When a horse is fed barley whole**



**grains in the dung will indicated that the animal has a tooth problem and is not chewing its food properly.**

**If bran (from oats) is available it can be fed damp (sprinkled with water), when it acts as a laxative and if fed dry it helps to regulate the gut and make the faeces normal.**

**Vegetables can also be added to the feed. Carrots should be sliced, turnips can be fed whole. Vegetable waste such as potato and apple peelings, carrot tops and cabbage leaves can be chopped up and added to a feed.**

## **Water**

**Animals should be given clean drinking water every day. A horse needs 25 to 30 litres of water per day but will need less when eating green grass. The horse will need more water when the food is dry or the weather is hot. Pregnant or suckling mares need more water.**

***Do not give water to tired or sweating animals as this can cause***

***colic. Walk the animals around and allow them to cool down for some time before giving them water to drink.***

## **Unit 47: Grooming and tackle (tack)**

***Grooming is the cleaning and brushing of the animal's coat which helps to keep the animal healthy and prevent skin problems.***

***Tackle is the equipment used on the animal so that it can be ridden (saddlery is used) or driven (harness is used).***

### **Learning objectives**

**After studying this unit you should be able to:**

- 1 Groom the animals.**
- 2 Care for wet animals.**
- 3 Know the correct harness and saddlery to use.**
- 4 Prevent wounds occurring from badly fitting tackle.**

### **Grooming (brushing) equines**

**Animals must be groomed daily. A strong, hand held brush (body brush) is used to remove loose hair and dirt from the coat. After two or three strokes with the brush, dirt and hair is removed from the brush by brushing it against a metal comb (curry comb). It is important to remove mud and dirt from the legs and feet or mud fever will develop (see Unit 42). The hooves should be examined daily and cleaned out with a hoof pick.**

**Animals should be lightly groomed before being fitted with harness or saddlery to avoid dirt being trapped underneath and causing skin problems.**

### **Grooming (brushing) equines**

Body brush



Curry comb

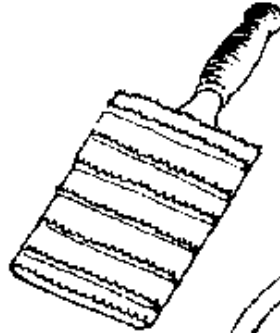

Hoof pick

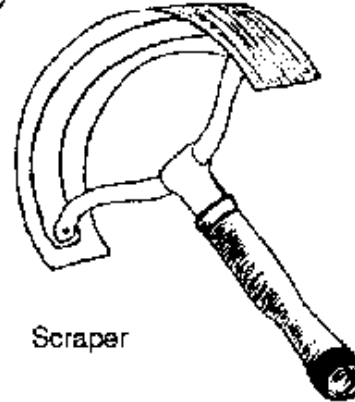

Scraper

## Caring for the wet animal

**When an animal returns to the stable soaked with sweat, rain or snow it must be dried immediately or it will become sick. The water must be removed from the coat using a metal scraper with**

**a handle which is drawn down over the coat. You can also remove water by twisting a handful of straw or hay into a curved shape and using this in downward strokes over the body. More straw, cloths or an old blanket should then be used to dry the animal by rubbing the body.**

### **Harness for working animals**

**To use the animal for draught work (pulling) it must wear harness. Mules, donkeys and horses need to wear collars to pull agricultural tools or carts. A horse can also pull loads wearing a breast girth. Mules and donkeys can carry loads of up to 100 kg and pull carts of 300 kg. Horses are stronger and can pull or carry heavier loads but they can be more difficult to train for the work. Horse collars, girths and the bridle (head harness) should be correctly fitted and not allowed to rub the animal.**

### **Harness for working animals**

Saddle with load

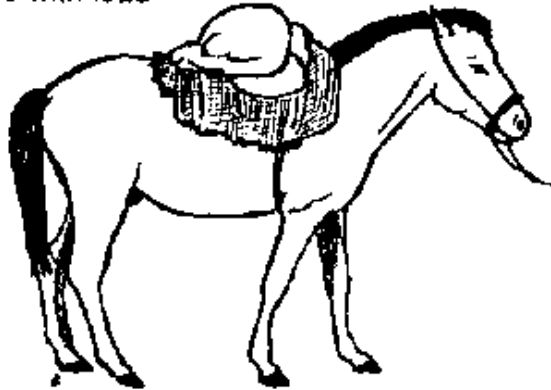

Collar

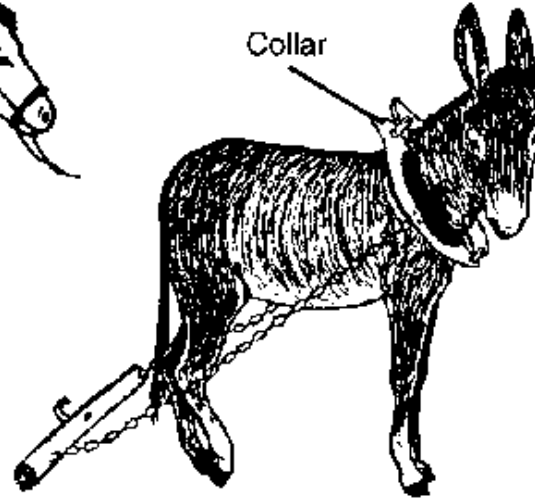

## Saddlery

**A saddle should always fit properly and have no stiff or rough edges that will rub the animal. It is advisable to put a cloth under the saddle especially in hot weather when a cotton cloth will absorb sweat.**

**Following a ride, when the animal is hot and sweating, you should**

**loosen the girth immediately, but leave the saddle in place for several minutes until the animal starts to cool.**

**Wounds from badly fitting tack (tackle).**

**Badly fitted saddles, collars, hobbles and girths will result in wounds which develop into sores. A badly fitted saddle will result in saddle sores and an ill fitted girth results in the development of girth-galls. The hair will be rubbed off and a wound develops which will become infected.**

**All harness and saddlery should be kept clean and care should be taken when putting it on the animal to ensure that it fits properly, does not rub, and that no folds of skin are trapped under the girths.**

**To treat any sores which develop it will be necessary to rest the animal and treat the wounds by cleaning and dressing with tincture of iodine or Dettol solution (see Unit 73).**

**Wounds from badly fitting tack (tackle).**

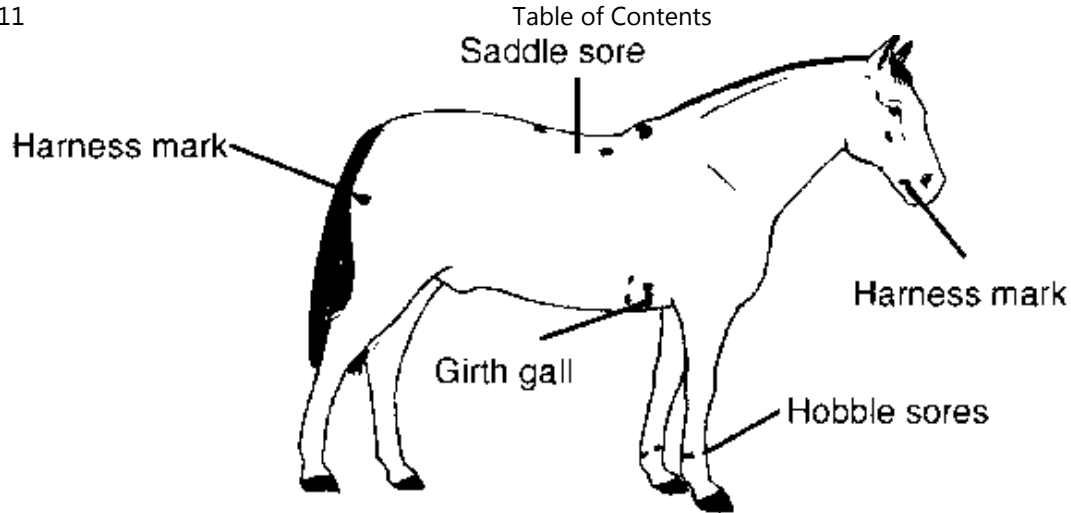

***Remember that lack of care and the use of badly fitting harness or tackle can result in the loss of the animal's ability to work.***

## **Unit 48: African horse sickness**

***African horse sickness is an infectious disease of horses, mules and donkeys and causes the death of a lot of animals.***

***Although called African horse sickness it is also found in Asia.***



## **Learning objectives**

**After studying this unit you should know:**

**1 What is African horse sickness.**

**2 Precautions to take against African horse sickness.**

### **African horse sickness**

**This is a disease which is spread by mosquitoes and affects mules, horses and donkeys. The signs of the disease can vary as there are a number of different germs which cause it.**

**The first sign of the disease is a fever with the temperature reaching 41 °C. The disease may then affect the heart, lungs or both the heart and lungs depending on which germs are causing the infection.**

**An animal infected with the lung form of the disease coughs and shows difficulty in breathing, but the main sign that the infection is African horse sickness is the production of a lot of yellow discharge from the nostrils. The infected animal will soon die.**

**The animal which is infected with the heart form of the disease has red swollen eyes. The head and neck region also becomes swollen and there is a blood spot under the tongue. Animals infected with this form may die or recover within 2 weeks of showing the first signs of the disease.**

**Animals infected with the heart and lung form suffer from swelling of the eyes, head and neck as well as the heavy discharge from the nose. Some may survive.**

### **Precautions against African horse sickness**

**There is no treatment for this disease. Vaccination is recommended but the pregnant animal must not be vaccinated.**

**If there are equines in your community talk to your veterinarian and arrange for them to be vaccinated.**

***Remember that this disease kills and can quickly spread through all the equines in your community if they are not vaccinated.***



---

## Chapter 6: Chickens and ducks

---

[Unit 49: Keeping chickens and ducks](#)

[Unit 50: Housing for chickens and ducks](#)

[Unit 51: Feeding chickens and ducks](#)

[Unit 52: Problems caused by poor feed \(deficiencies\)](#)

[Unit 53: Incubators and brooders](#)

[Unit 54: Brooding](#)

[Unit 55: Internal parasites of chickens and ducks](#)

[Unit 56: External parasites of chickens and ducks](#)

---

### Unit 49: Keeping chickens and ducks

***It is not a good practice to allow chickens, ducks and other birds***

***to freely wander around the community to feed and drink whatever they can find.***

***Providing shelter, food and clean water to these birds will result in more meat and eggs.***

***Birds can easily become sick and some diseases kill many birds. Veterinary advice on vaccinations to stop diseases is essential.***

## **Learning objectives**

**When you have studied this unit you should know:**

- 1 Traditional ways of keeping birds.**
- 2 Better ways of keeping chickens and ducks.**
- 3 The quality of eggs.**
- 4 Vaccination and veterinary aid for chickens and ducks.**

## **Traditional ways of keeping birds**

**Many communities keep birds to provide meat and eggs for feasts, weddings and other social activities. Sometimes birds are**

**sold for the extra money needed for urgent medicines or food. Many people in the community may keep birds but with limited good results. This can be because:**

- **Birds are not fed well, but are left to pick up what food they can find on the roads, and to drink dirty water.**
- **They are not provided with shelter (housing) and can become the victims of cold, rain, foxes and other predators.**
- **The types of birds (breeds) kept in the community are small birds or those which do not lay large numbers of eggs.**

**Because of the way they are kept most of the young die and very few birds reach the age of one year. The birds that do survive are small and produce little meat. Many birds must be killed to provide sufficient amounts of meat and little money is obtained by selling them.**

## **Better ways of keeping chickens and ducks**

**You can improve the amount of meat and eggs you get from birds by:**

- **Keeping better breeds (types) of birds which are bigger and lay more eggs.**
- **Improving the quality of the birds you have by mating them with better quality males.**
- **Provide housing for birds and good feed and water.**

**You should try to find out which breeds are available and try to obtain birds which are bigger, produce more meat, and which lay more eggs. You should encourage the community to start to keep these birds or at least to use some to improve the birds they have. There are several ways of introducing better quality birds into the community's flocks:**

- **Buy male birds of the better breed to mate with females you have.**
- **Buy day old chicks from the better breed and rear**

**them.**

- **Buy some birds at 2 to 3 months of age (this is the best way).**

## **The quality of eggs**

**Chicken eggs will stay fresh longer than the eggs of a duck. Eggs should be kept in a cool place. If placed in a fridge the chicken eggs will stay fresh for 3 weeks while those of the duck must be used within 10 days.**

- **An egg produced by a female bird kept without a male is called a non fertile egg and will keep fresh for a long time.**
- **Eggs from a female kept with a male bird are alive and the young chick will start to grow in them if they are kept in a warm place.**
- **To check eggs hold them against a light or the sun, or candle them (see Unit 53).**

## The fertility of the egg

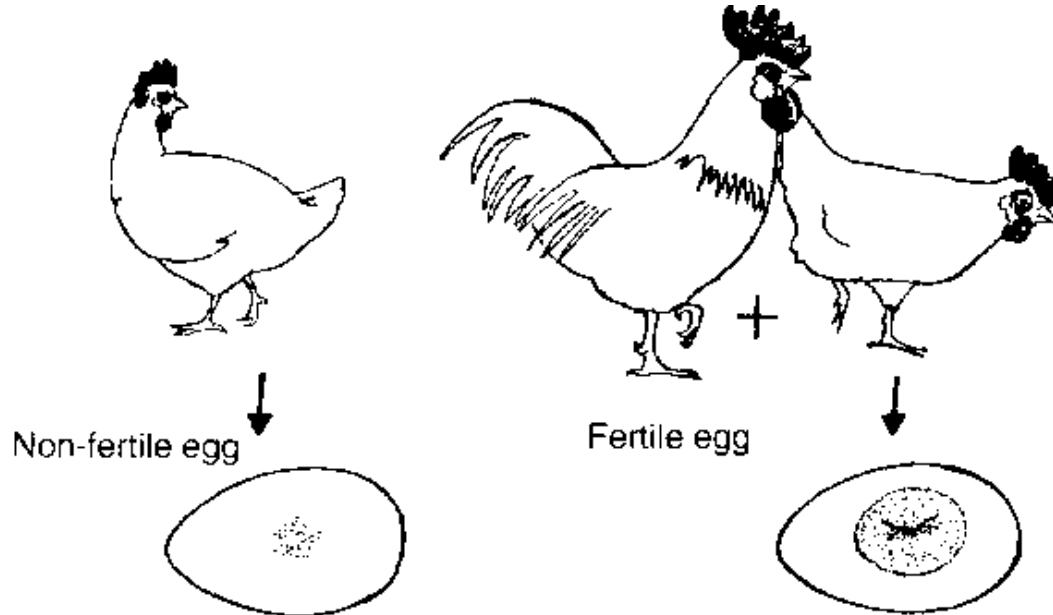

**Eggs should be cleaned before they are sold or used. Wipe them with a damp cloth but never wash them in warm water. If eggs are placed in a container of cool clean water, bad eggs which cannot be eaten, will float to the top of the water. Good eggs stay at the bottom. When you use eggs, the condition of the yolk (yellow)**



**and the white of the egg, tells you how good the egg is.**

### **The quality of eggs**



Good egg

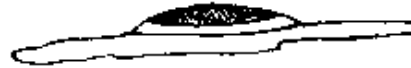

Poor egg



Bad egg

### **Vaccination and veterinary aid for chickens and ducks**

**You should talk to your local veterinary officer and discover what diseases occur in the birds in your area. He will be able to tell you what can be done to prevent disease and obtain any vaccines which you can then use to protect birds against these infections.**

***Take the business of keeping birds seriously. The benefits from keeping them are the same as those gained from keeping other***

**animals.****Unit 50: Housing for chickens and ducks**

***If birds are allowed to wander around freely, disease can spread quickly through all the birds kept in the community.***

***Keeping birds in a closed area and providing them with shelter is the first step towards improving them.***

***A covered shelter (house) will give chickens and ducks protection from wind, rain, snow and predators such as foxes.***

**Learning objectives**

**After studying this unit you should know:**

- 1 Why chickens and ducks should be housed.**
- 2 How many birds can be kept together in a house.**
- 3 How to build a house for chickens.**
- 4 Nesting boxes (for laying eggs).**
- 5 Runs (fenced areas) for birds.**

## **6 The differences between houses for chickens and ducks.**

### **Why we house chickens and ducks**

#### **If chickens and ducks are kept in houses:**

- **They will be protected from the sun, rain, cold and snow.**
- **They will be protected from other animals such as foxes and birds of prey, from theft and from being killed on the streets.**
- **Young birds are protected.**
- **Food and water can be controlled.**
- **Birds can be prevented from eating bad food or drinking dirty water.**
- **Nest boxes can be provided to make it easy to collect**

## **eggs.**

- **The spread of disease can be stopped.**

## **How many birds should be kept in a house**

**There must be enough space to hold all the birds plus the feed and water containers (troughs). If too many birds are kept together they will start to peck (bite) each other. If any bleed, the problem will become worse, as more birds start to peck. Young birds will need less space than older birds and perches must be provided for chickens to roost on at night.**

**The ground or floor area required is:**

- **50 chickens can be kept in 16 square metres (4m × 4m).**
- **1 metre of perch must be provided for every 5 adult chickens.**

## **Housing for chickens**

**Suitable housing for chickens should be:**

- **Built on high ground close to the home of the owner so that he can keep an eye on it.**
- **The house should be 2 metres high and it is better if the first 50 cm of the walls are brick, stone or concrete while the rest is wood, wood and mesh wire, corrugated iron sheeting or any other suitable materials. Small houses can be made from wood and mesh wire.**

### **Runs for birds (fenced areas)**

**Every house will need a run for the birds to be able to exercise in, pick up grass, insects etc. The run must be fenced around with wire or other suitable material and if possible should be shaded by some trees. Part can be covered to allow birds to use it on rainy days. If possible the run should be divided into two areas to keep birds out of one area to allow fresh grass to grow 50 chickens require a 16 square metre house and 500 square metres of run.**

### **Runs for birds**

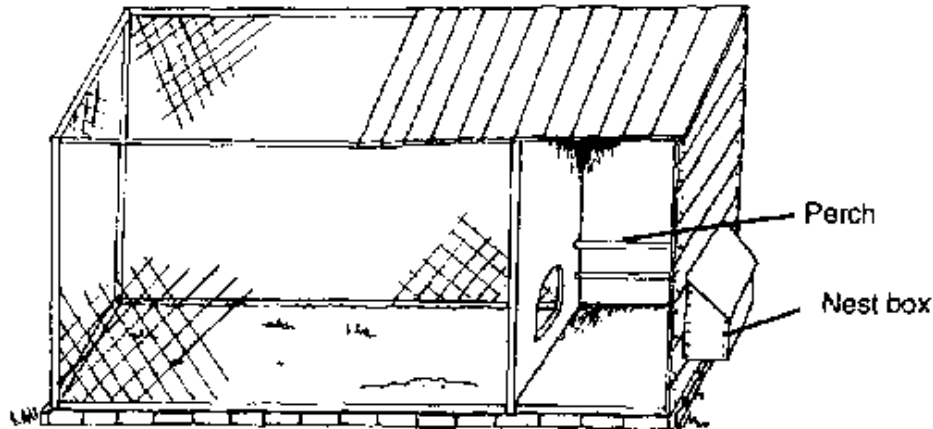

## **Nesting boxes (for laying eggs)**

**Nesting boxes are boxes in which the hen can lay her eggs. You can make them from wood, baskets or pottery. Line them with straw or hay as a nest. Wooden boxes can be built on to the side of the house and opened from the outside to remove the eggs.**

## **Housing for ducks**

**Housing for chickens can be used for ducks. However if you keep ducks you should remember:**

- Ducks do not require perches and nesting boxes will need to be low to allow ducks to use them, or sloping ramps must be placed to allow ducks to get to the boxes.
- You will need to provide ducks with a container of water at least big enough for them to put their heads and necks into the water.

### Housing for ducks

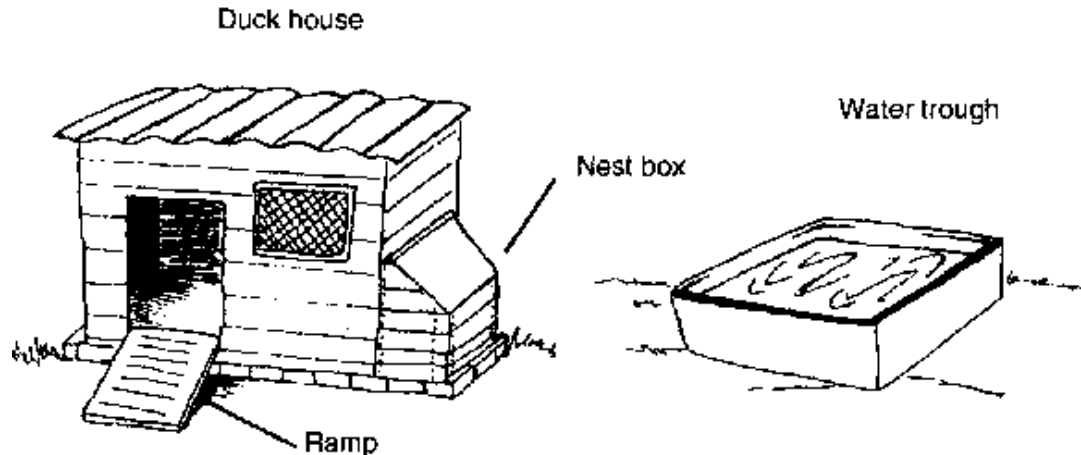

**Laying ducks must be kept in the house each morning until they lay their eggs.**

## **Unit 51: Feeding chickens and ducks**

***In order to get good meat and egg production from birds they must be given good feed containing necessary nutrients.***

***If birds are allowed to wander freely and eat whatever they can find they will not grow properly, will produce little meat and few eggs.***

### **Learning objectives**

**After studying this unit you should know:**

- 1 The digestive system of birds.**
- 2 What the bird needs in its feed.**
- 3 The different feeds for chickens and ducks**
- 4 Rations for chickens and ducks.**
- 5 How much water birds need.**



## **The digestive system of the bird**

**The bird has no teeth, food is swallowed whole and goes into the crop where it is stored and mixed with saliva. If you feel the crop you can tell if a bird has been feeding or not.**

**The feed passes from the crop into the stomach where it mixes with the juices before passing into the roundish, thick walled, muscular organ called the gizzard. The gizzard contains small stones which the bird has eaten to help the gizzard to grind up the food for digestion. Nutrients are absorbed as ground up feed passes along the intestine.**

## **The digestive system of the bird**

## Digestive system of bird

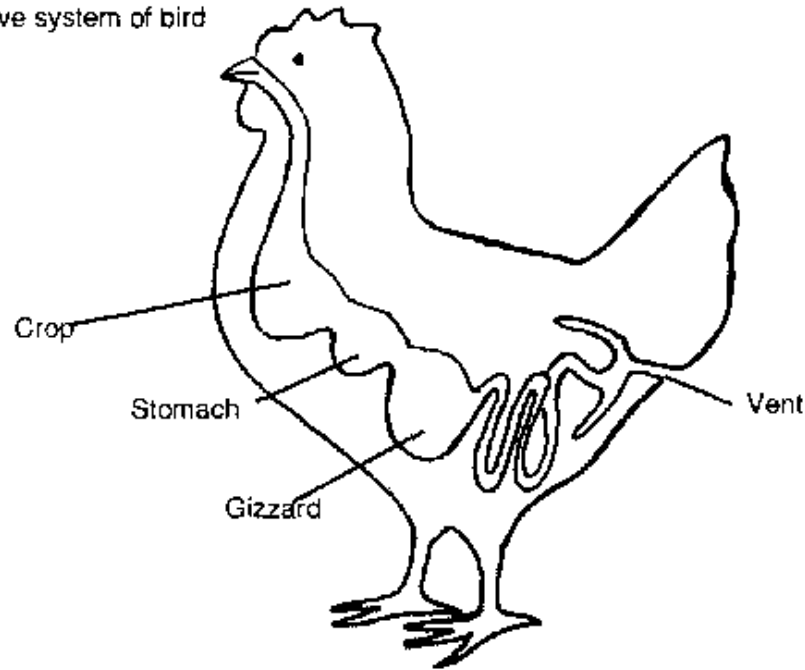

**Birds do not produce liquid urine. Waste from the kidneys forms a thick white material which is mixed with the faeces (droppings). Both are then passed out through the cloaca. The duck produces wetter droppings than the chicken.**

## **What the bird needs in its feed**

**Like other animals, birds require carbohydrates, proteins, fats, minerals and vitamins in their feed (see Unit 23).**

**At different times of their life birds will require rations that contain different amounts of carbohydrates, proteins, fats, minerals and vitamins:**

- **From hatching (1 day old) to 3 months of age, birds will need feed which contains large amounts of protein for body growth.**
- **When birds are laying eggs minerals are important in producing good eggs.**
- **Birds kept for meat will need a lot of protein in their feed.**

## **Feed materials for birds**

**Different feeds are important for the nutrients which they contain.**

- **Carbohydrates are found in grains which can be fed whole or ground as meal. Birds can be given corn, rice, maize, barley, oats, sorghum, finger and bulrush millet, or bran from rice or other grains.**
- **Cake from the processing of groundnuts, cottonseed or dates can also provide carbohydrate and protein. Soya bean meal also contains proteins. These types of protein-rich feeds are from plants while animal products such as fish meal, milk powder and dried blood also contain proteins and can be fed to birds.**
- **Birds must not be given too much animal protein. Not only is it expensive but too much of it may cause some diseases to occur in the animals. Too much fish meal can make eggs taste fishy.**
- **Fats are found in cottonseed, groundnuts and sunflowers.**
- **Minerals are in bone meal (ground bone) egg shells and**

**old seashells which can be ground and added to the feed. If cuttlefish bone is available locally it is an excellent source of minerals.**

- **Vitamins may be supplied by adding green plants to the feed or by adding commercially produced vitamins.**

***Your veterinary officer will be able to advise you about commercially available vitamin supplements and how to use them.***

**Your waste food can be fed to birds if it is cut up and boiled. It can then be mixed with meal and fed to the birds.**

## **Rations**

**The ration will change with the requirements of the bird. Young birds need a ration which is rich in protein while laying birds need plenty of minerals. Some examples of rations are given.**

<b>Age of Bird</b>	<b>Whole &amp; ground</b>	<b>Cake</b>	<b>Protein</b>	<b>Minerals</b>
--------------------	---------------------------	-------------	----------------	-----------------

	<b>grain</b>	<b>plant/animal</b>		
<b>up to 8 weeks</b>	<b>7 parts</b>	<b>2 parts</b>	<b>1 part</b>	<b>0.25 part</b>
<b>8 - 12 weeks</b>	<b>8 parts</b>	<b>1.5 parts</b>	<b>1 part</b>	<b>0.25 part</b>
<b>Laying</b>	<b>8 parts</b>	<b>1.5 parts</b>	<b>0.25 part</b>	<b>0.50 part</b>

**The ration should be thoroughly mixed and then water added until it becomes crumbly (like grain) before feeding it to either chickens or ducks.**

**For chickens whole grain can be scattered over the run encouraging birds to scratch as they feed and so take in minerals from the soil. Ducks can be offered whole grain in a trough of water or given dry.**

**Always clean out unused feed daily. Green vegetables can be hung up in the run to encourage the birds to show an interest and not peck at each other.**

## **Water**

**Birds need clean fresh water at all times. Every 4 chickens will need 1 litre of water every day and this will double as the weather becomes hotter.**

**Ducks need more water than chickens each day. Ducks do better if they have enough water in which to dip their heads and necks.**

### **Unit 52: Problems caused by poor feed (deficiencies)**

***A deficiency means that the bird does not get enough of a particular nutrient. All animals can suffer from deficiency problems but in birds a deficiency very quickly shows signs of:***

- poor health***
- leg problems***
- poor feathering***
- egg production drops***
- eggs have thin shells***
- birds easily take infections***

## **Learning objectives**

**After studying this unit you should know:**

- 1 Protein deficiency.**
- 2 Problems caused by a lack of minerals.**
- 3 Problems caused by vitamin deficiencies.**

### **Protein deficiency**

**If the feed contains too little protein (animal or plant) the birds will become weak and may develop infections. They do not grow well and meat production is badly affected. Egg laying decreases or stops.**

### **Mineral deficiencies**

**Lack of calcium in the feed can cause:**

- The bones of the leg to curve making the bird unable to walk properly**
- Soft shelled eggs or eggs without shells are laid**



**If birds lay eggs that have either no shell or a soft shell these eggs will be broken and can be eaten by other birds. If this happens the chicken can develop a habit of eating eggs which then becomes a problem.**

**To prevent these problems birds must be given plenty of minerals as powdered shell or bone. If birds are allowed to scratch for grain they will take in minerals they need from the soil in the run. A good source of minerals is to feed crushed egg shells to the birds.**

### **Problems caused by a lack of vitamins**

**If vitamins are not present in the feed then:**

- Birds do not grow well, are weak, cannot move properly and the feathers are ruffled.**
- Chest problems can occur and birds have nose and eye discharges.**
- The toes curl inwards and birds have difficulty in moving.**

**These problems can be prevented by adding commercially bought vitamins to the feed or providing the birds with green vegetables in addition to the feed. Vitamin deficiencies can cause birds to start feather picking which becomes a problem.**

### **Problems caused by a lack of vitamins**

#### **Results of deficiencies**

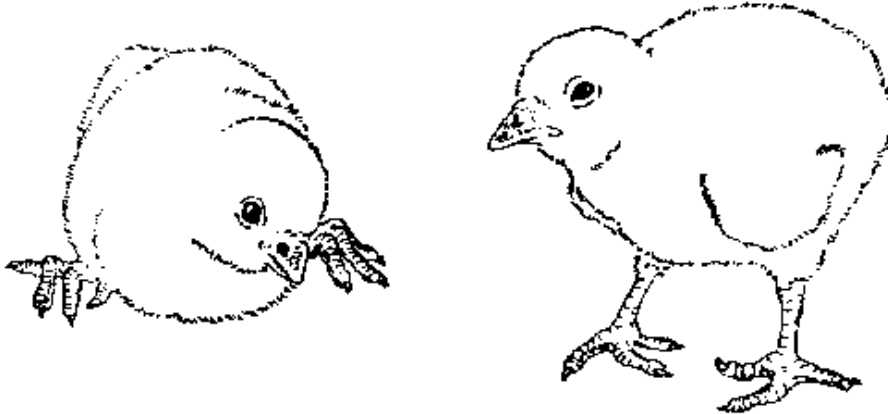

## **Unit 53: Incubators and brooders**

***Natural incubation by the female bird is the simplest way of***

***hatching eggs. To hatch a large number of eggs you can use a small incubator which is heated by kerosene (paraffin) or electricity.***

***The condition of the eggs in the incubator can be checked by the method of candling (looking at the eggs with light).***

***When the young chicks are hatched they are kept in a brooder which has some form of heating and suitable feed and water containers (troughs).***

## **Learning objectives**

**After studying this unit you should know:**

- 1 How to use an incubator.**
- 2 How to check eggs by candling.**
- 3 How to keep young birds in a brooder.**
- 4 The types of food and water troughs to use.**

## **Incubators (for hatching eggs)**

**If your community has a small incubator you will be able to incubate and hatch eggs with good results if you do the following:**

- **Choose eggs that are not too small, too large or which have thin or cracked shells.**
- **Run the incubator for a few days first to check that the temperature is steady at 39.5°C.**
- **Make sure that the incubator is level and that the temperature of the room where it is kept stays fairly constant (15 - 20°C).**
- **Make sure that you have enough kerosene or that your electricity supply is reliable.**
- **Make sure that the thermometer is on a level with the eggs.**
- **Control the moisture and check that there is always**

## **water in the tray inside the incubator.**

- **Do not touch the eggs with a dirty hand or after you have been handling any kerosene.**
- **Turn the eggs twice a day for the first 18 days and move them around (as the mother bird would do).**

**The incubation time for chickens is 21 days and from day 18 the eggs should not be touched and the incubator should not be opened.**

**Duck eggs need 28 days to incubate and must be sprinkled with water twice a day for the last 14 days.**

## **Candling (checking the eggs)**

**Eggs can be incubated and after a lot of care no young hatch because the eggs were not fertile. In order to avoid this happening you need to check the eggs. To do this you will need a small box with an electric light, torch or any other source of light in it. If you hold the egg against the light (or strong sunlight) you**

**will be able to see if it is fertile or not.**

### **Candle box**

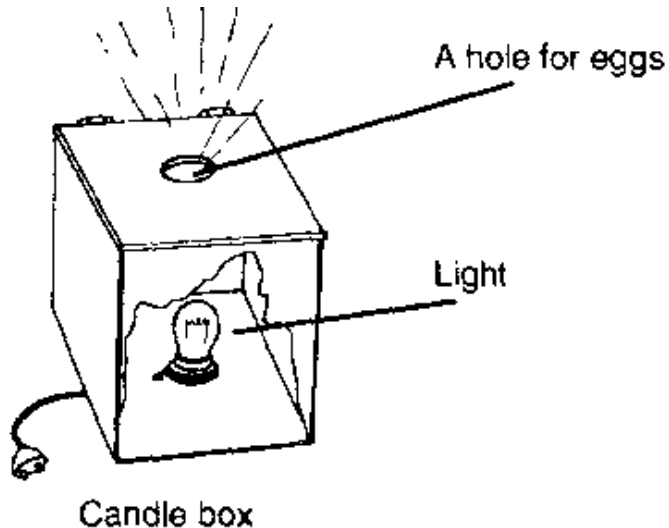

**You will need to check eggs:**

- **Before putting them in the incubator**
- **7 days later**
- **On day 18 of the incubation Period**

## Candling

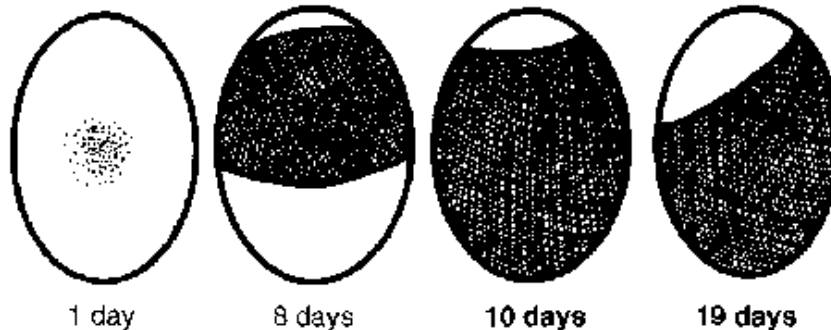

### **Brooder (for keeping very young birds)**

**If you buy young birds, or hatch them in an incubator, you will need to keep them in a brooder for a few weeks. You can buy a brooder or make your own.**

**Brooders have a source of heat to replace the heat that the young would have from their mother. In the brooder they are protected from animals and the weather.**

**A simple brooder is made from a heavy box or basket and a**

**hurricane lamp (kerosene lamp) as the source of heat. A 1 metre square box will make a brooder for 25 baby birds. The lamp is surrounded with wire mesh to stop the birds from touching it. Troughs (containers) for feed and water must be placed in the brooder and the birds can be kept in it until they are 4 weeks old.**

## **Brooder**



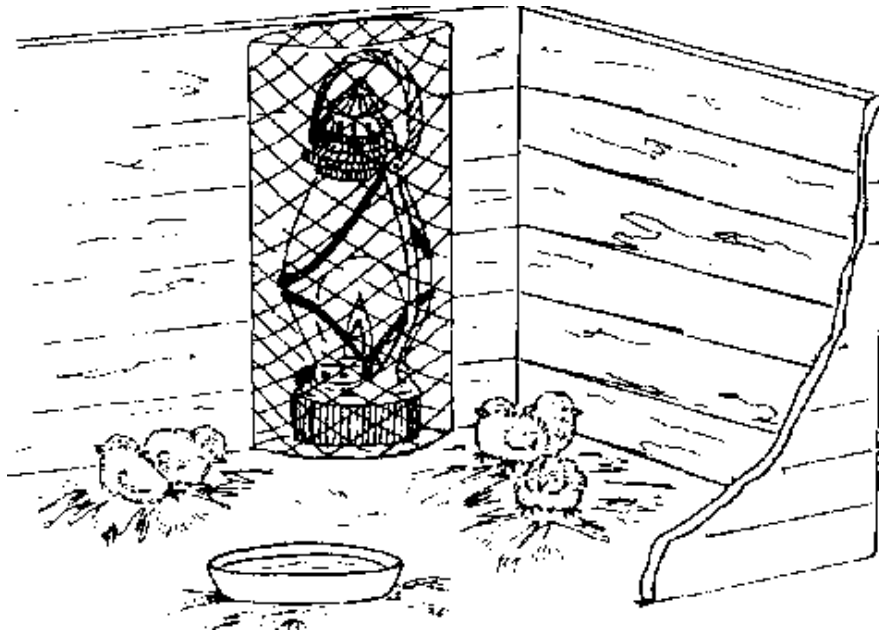

**When birds have reached 4 weeks of age they do not need the heat of a lamp and are too big for the brooder. They should be placed in a fenced area (run) with a box covered with hay, straw, paper or cardboard. They can go into the box for warmth when they need it.**

## **Water troughs (containers)**

**Birds will drink a large amount of water and in hot weather can drink up to half a litre a day. Water troughs must be clean and birds should not be able to get inside them. You can buy troughs or cover a suitable container with wire. Water can also be given using a bottle held over a container.**

**Ducks need enough water to cover their heads. They can splash water around which can cause problems. Placing the water container for ducks in a wood and wire mesh frame stops the birds reaching the muddy ground.**

### **Water trough**



Water trough

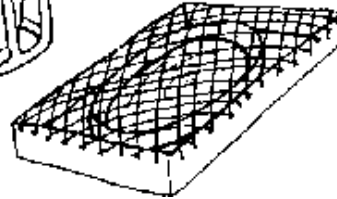
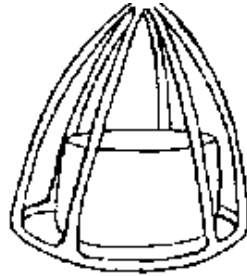

## **Feed troughs (containers)**

**Feed troughs can be bought or made from wood. The troughs must be big enough for all the birds to eat from it.**

**A good trough for chickens is made from a wooden base with two perches on each side for the birds to stand on to feed. The height of the trough varies with the age of the birds. Across the top of the trough is placed a pole which will turn around if any bird tries to perch on it.**

**Ducks need shallow troughs or flat containers for feed.**

## Feed trough

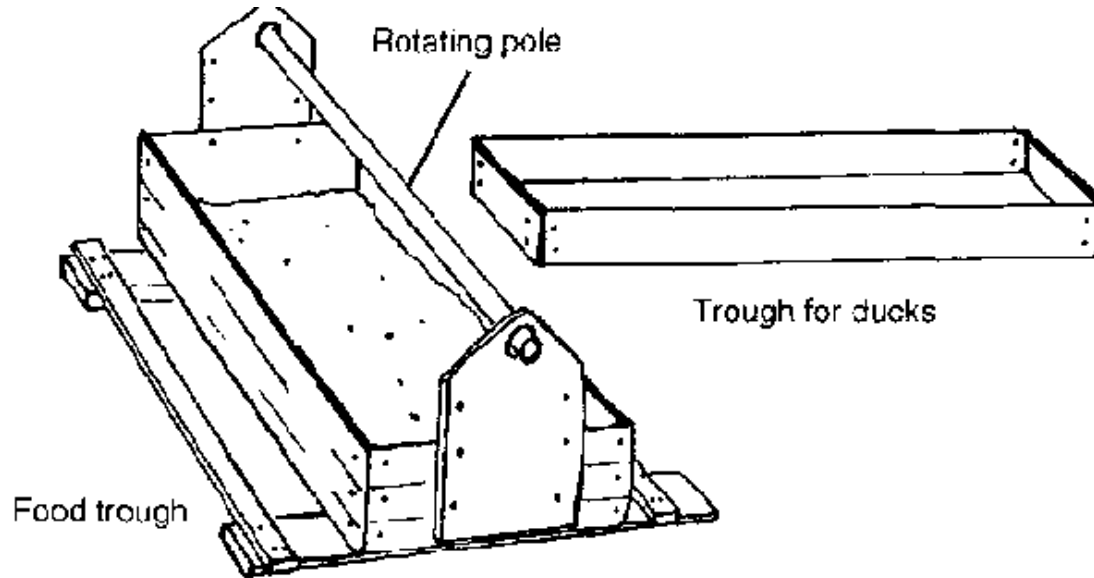

### Unit 54: Brooding

***When the female bird sits on her eggs in a nest to incubate them she is brooding.***

***Natural incubation or brooding is the simplest way of hatching a small number of eggs. A broody hen (chicken) will incubate her own eggs or those of another hen or a duck.***

***Broody hens may refuse to leave the eggs to eat or drink. They can suffer from external parasites (e.g. mites, fleas). Care must be taken to feed the hen and treat her for parasites.***

## **Learning objectives**

**After studying this unit you should know:**

- 1 How to know that the hen is broody.**
- 2 Using the broody hen to incubate chicken and duck eggs.**
- 3 Care of the broody hen.**

## **The broody hen**

**New breeds (types) of chickens may not be good brooders. A good test to check the broodiness of the bird is to put some white balls, or a few hardboiled eggs, in its nest for a day or two.**

**If the bird stays in the nest, and will not easily move off, replace the eggs with 10 - 15 fertile eggs which have been checked (see Unit 53).**

**Natural incubation is the simplest way to hatch small numbers of eggs and the broody hen can be used to incubate and hatch her own eggs or those from another bird. A hen can incubate 12 to 15 chicken eggs or can be used to incubate up to 10 duck eggs.**

### **The broody hen**

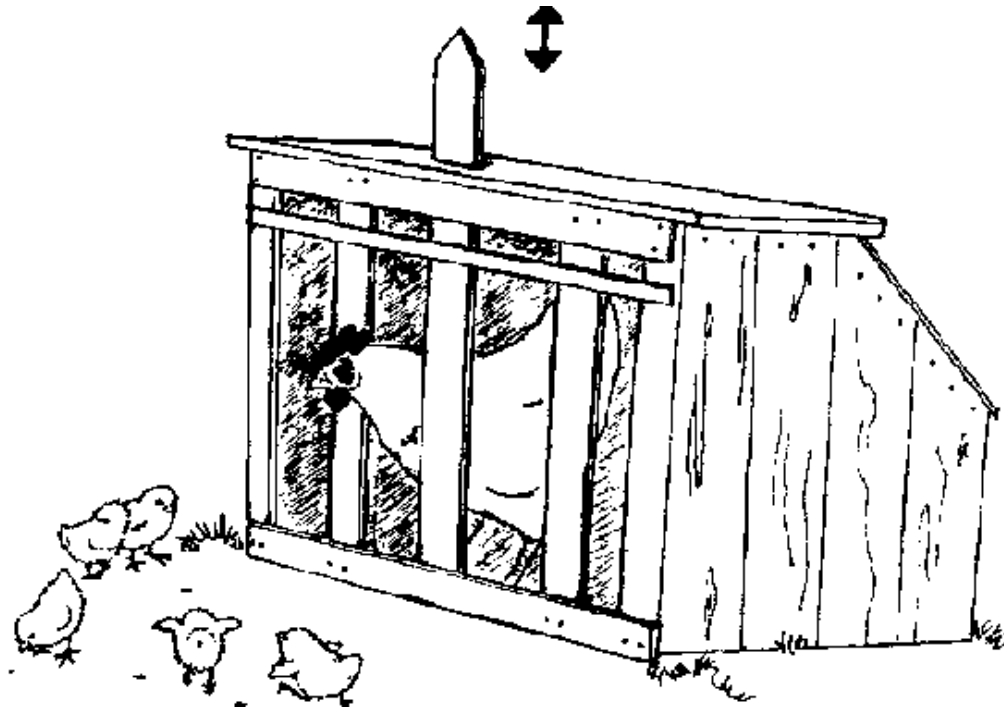

**The broody hen is kept in a nesting box. Take her off the nest for 20 minutes each day to give her feed and drink. If a hen is used to incubate duck eggs you will need to sprinkle them with water for the last 14 days of the incubation period.**

**The eggs of turkeys can also be incubated by a hen. A female turkey will lay up to 15 eggs but a brooding hen can only incubate up to 9 turkey eggs.**

## **Care of brooding hens**

**To ensure that the brooding hen does not have any external parasites (Unit 56), she should be treated with a suitable dusting powder (see R15 Annex 1) before being placed in the nesting box. The nesting material should also be lightly dusted with the powder. This will prevent any parasites being passed on to the chicks. Any holes in the box should be closed to prevent rats getting at the eggs and eating them.**

**White diarrhoea disease kills large numbers of chickens. Do not hatch the eggs of birds which have been infected with this disease. The germ which causes the disease will be in the eggs and will infect the chicks. Ask your veterinary service about this disease in your area.**

## **Unit 55: Internal parasites of chickens and ducks**



***The gut of chickens and ducks can be infected with a number of different roundworms. Heavy infections cause weight loss, diarrhoea and poor egg production.***

***The thin, red gizzard worm lives in the wall of the gizzard of ducks and is the cause of loss of appetite, weight loss, diarrhoea and death of birds.***

***Both chickens and ducks can be infected with very small parasites called coccidia which live in the wall of the gut. These cause diarrhoea, weight loss and can result in the deaths of very many young birds.***

## **Learning objectives**

**After studying this unit you should know:**

- 1 The problems caused by worm infections of chickens and ducks.**
- 2 The problems caused by coccidia in chickens and ducks.**

### **3 How to treat infected birds.**

### **4 Ways of preventing parasitic infections of birds.**

#### **Parasitic worms of chickens and ducks**

**Chickens and ducks become infected with worms from soil, feed or water contaminated with worm eggs. Worm eggs survive in warm, damp conditions.**

**A large white roundworm (10 cm long) is found in the intestine. Small, fine hairworms live in the gut walls. Other worms, about 1 cm long, can be found in the lower region of the gut.**

- Worm infections are of greatest importance in young birds and cause poor appetite, loss of weight and diarrhoea. Heavy infections can cause death. In older birds loss of weight and poor egg production occurs.**
- The gizzard worm causes loss of appetite, weight loss, and diarrhoea and may result in the death of ducks, especially young birds.**

## **Coccidia in chickens and ducks**

**Coccidia cannot be seen without a microscope. Many different coccidia infect different parts of the gut in both chickens and ducks. Birds are normally infected with a number of different coccidia.**

**Birds are infected by contaminated soil, feed or water and will suffer few problems if the infection is low. Young birds, especially under a month old, can be badly affected. Diarrhoea occurs and the droppings may be bloody. Coccidia can kill young birds within 2 weeks of the disease appearing.**

***Coccidia are the cause of a dangerous disease of young chicks. Ask your veterinarian for advice on this disease. It may kill all the young birds in your community.***

## **Coccidia and worms in birds**



## Treating parasitic infections of birds

**Worms can be killed by treating the bird with a suitable anthelmintic (see R14 Annex 1). All worms are killed by tetramisole or levamisole. Birds are either treated separately or the drugs are mixed with the feed or water. Coccidia are treated with several drugs (see R18 Annex 1) which are added to the drinking water or feed.**

## Preventing parasitic infections in chickens and ducks

**Infection with all internal parasites in both chickens and ducks can be controlled by keeping birds in clean conditions and stopping them wandering around free.**

- **Cages and houses should be kept clean with droppings removed every week.**
- **Feed and water containers should be cleaned out every day.**
- **Do not allow wet muddy areas to develop around water containers or anywhere else.**
- **Cages and houses should be thoroughly cleaned before new birds are placed in them.**
- **Do not keep birds on the same area of ground year after year as contamination of the soil will increase.**
- **Young birds should be kept separate from older birds.**
- **Do not place young birds, especially under 3 months**

**old, in runs where older birds have recently been kept as they may develop infection with coccidia.**

- **If possible regularly treat young birds for coccidia (ask your veterinarian for advice).**

***When you buy new birds ask your veterinarian or agricultural officers who is selling good birds which will not bring disease into your community's birds.***

## **Unit 56: External parasites of chickens and ducks**

***A number of lice and mites infect birds and cause severe irritation which leads to loss of feathers, loss of weight and low numbers of eggs.***

***Small ticks feed on the blood of birds and can carry germs which will cause other diseases.***

***External parasites will hide in the walls, floors and bedding of the cages and houses where birds are kept. In order to control***

***the parasites it is necessary to keep these places clean and kill any parasites there.***

## **Learning objectives**

**After studying this unit you should know:**

- 1 The mites, fleas and lice which infect chickens and ducks.**
- 2 Problems caused by flea, lice and mite infections.**
- 3 Tick infections of chickens and ducks and the problems they cause.**
- 4 How to treat infected birds.**
- 5 How to keep houses and cages clean and free of parasites.**

## **Fleas, mites and lice infecting chickens and ducks**

### **Fleas:**

**Fleas are small and dark in colour and can jump high into the air. They feed on blood and can live without food for a long time. The**

**eggs and young of fleas are found in the birds' nests and cracks in walls and floors of buildings.**

**One type of flea is found on the wattles and comb of chickens and does not jump away. Its bite causes ulcers to form and large numbers can kill young birds. It also infects ducks and is found around the eyes. They can bite people.**

**Mites:**

**A number of different mites infect birds and cause irritation and loss of feathers. The scaly leg mite can cause lameness. Red mites can kill birds and will also bite people.**

**Fleas and mites**



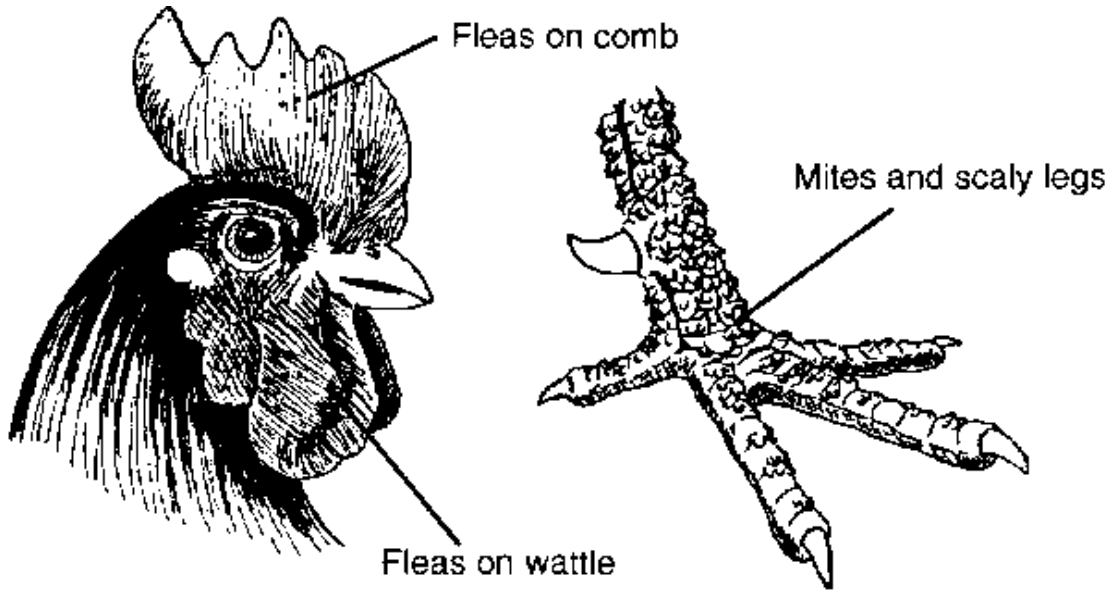

## Lice:

**Chickens can be infected with a number of lice which suck blood and chew the skin. Ducks can also suffer from infections with lice. The parasites can attack all areas of the body and are found on the skin and feathers.**

**Lice infections cause irritation and prevent birds from resting, sleeping and eating properly. The birds lose weight and egg production drops. Loss of feathers can occur in chickens.**

**In ducks infection with lice can damage feathers so that the birds die from cold.**

### **Ticks infections of chickens and ducks**

**Both chickens and ducks can be attacked by the small, blue or brownish fowl tick. They live in cracks in walls or trees and can live for several years without feeding on the blood of a bird. The tick feeds at night and can cause egg laying to stop. It causes tick paralysis in ducks and spreads other infections.**

### **The infections of chickens and ducks**

Tick

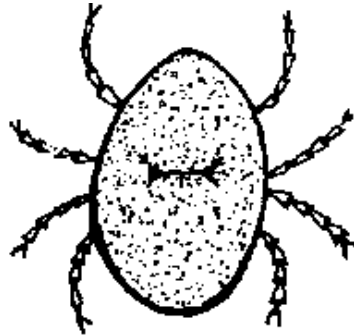

Flea



Mite



Louse



## How to treat infected birds

**To control external parasites birds must be treated with a powder or spray containing, e.g. trichlorphon or malathion (see R15 Annex 1). The cages and houses must be thoroughly cleaned.**

**Chickens will clean their feathers daily with soil or sand (a dust bath). A shallow box containing sand and ashes (left from a fire) will be used by birds and helps to keep the feathers clean and free of infections. A light dusting of a dusting powder (see R15 Annex 1) will make the dust bath better.**

### **How to treat infected birds**

**Scaly leg of chickens can be treated by dipping the leg in paraffin (kerosene) and then gently brushing the leg. Paraffin must not be allowed to touch the skin or feathers.**

### **Cleaning cages and houses**

**If birds are infected with external parasites it will be necessary to thoroughly clean out cages and houses. All bedding and dirt must be removed and all parts of the equipment should be thoroughly scrubbed with soap and hot water. If possible you should then spray or paint the equipment with a mixture of paraffin and creosote in equal amounts or with nicotine sulphate (40%). Your veterinary service will advise you on what is available locally for**

**you to use.**

**You can use a hand pump to spray houses. You can spray with a treatment for external parasites and your veterinary officer can advise you on this.**

***Remember:***

***Some of the external parasites of chickens and ducks can bite humans and cause irritation and skin rashes, especially in children.***

***Infected birds must be treated and the places where they are kept should be thoroughly cleaned and sprayed to kill any parasites there.***

***Ask your veterinarian for advice as external parasites can be a great problem in keeping birds.***





---

## Chapter 7: Camels, llamas and alpacas

---

[Unit 57: Camels, llamas and alpaca](#)

[Unit 58: Ageing camels by the teeth](#)

[Unit 59: Breeding camels](#)

[Unit 60: Milk and care of the young camel](#)

[Unit 61: Feeding and watering of camels](#)

[Unit 62: Surra of camels \(trypanosomiasis\)](#)

[Unit 63: Internal parasites of camels](#)

[Unit 64: Skin diseases of camels](#)

[Unit 65: Foot problems in camels](#)

---

### Unit 57: Camels, llamas and alpaca

***Camels live in Africa and Asia. Camels can live in dry lands where there is little feed and water available. Most are one-***

***humped but in northern areas where there are cold, dry lands two-humped camels are found.***

***Camels are used for meat, milk, fibre (wool and hair), for transport and for other work and their dung is used for fires. Camels provide everything in a desert environment.***

***Llamas and alpacas are small camel-like animals from the cold, dry mountain areas of South America. They are used for meat and wool. The llamas are also used as pack animals (to carry loads)***

## **Learning objectives**

**After studying this unit you should know:**

- 1 What camels are used for.**
- 2 What llamas and alpacas are used for.**
- 3 Keeping llamas and alpacas.**

## **The camel**

**Camels are cheap to keep as they can live on feed such as thorny bushes which other animals cannot eat. If they are fed and kept well they do not get many diseases.**

**Camels are used for riding, transport and agricultural work. In some areas they are kept for their milk as they can produce more milk from poor feed than other milk animals. Camel meat is eaten and the fibre (wool and hair) is used. Today in some areas camel bone is used for hand crafts.**

### **Alpacas and llamas**

**The very fine wool of the alpaca is used to produce clothes and the animals are sheared every year. There are two types of alpaca:**

- **Suri, which has long fine wool, each animal produces about 2.5 kg.**
- **Huacayo, which has shorter wool, each animal producing 2 to 3.5 kg.**



**The wool of the llama is coarse and is used for such things as ropes and saddle bags. The llama is sheared once every two years and gives about 3.5 kg of wool. Llamas are used as pack animals and can carry loads of up to 30 kg for 15 to 20 kilometres a day.**

### **Keeping llamas and alpacas**

**The animals can breed at 1 year of age but it is better to breed from them first when they are 2 or 3 years old. Both males and females are kept together. The female gives birth in the rainy season, which is December to March, and comes into heat immediately after giving birth.**

**Llamas can browse and graze, alpacas graze. Both are like sheep and cattle and need water each day. Both the alpaca and the llama use communal dung heaps. The dung of these animals is dried and used for fires. The diseases of llamas and alpacas are similar to those found in camels and ruminants. They can suffer from:**

- Mange, tick paralysis and ringworm (see Unit 64)
- Foot and mouth disease and rinderpest (see Unit 75)
- Rabies, from dogs or foxes (see Unit 78)
- Hydatid disease (see Unit 80).

***The following units (Unit 58 to 65) are on the camel with some reference made to the llama and alpaca.***

## **Unit 58: Ageing camels by the teeth**

***It is not a simple task to age a camel. Camels can be aged up to 7 years while llamas and alpacas can be aged up to 5 years.***

***The camel has 22 milk teeth and 32 permanent teeth. It is different to other ruminants in having two front teeth in the upper jaw. Camels also have a pair of canine (dog teeth) in both the upper and lower jaws which are used to crush woody plants for food.***

***The first pair of permanent cheek teeth are separate from the other teeth and are dark in colour.***

## Learning objectives

After studying this unit you should be able to:

- 1 Recognise the milk teeth of camels.
- 2 Recognise the permanent teeth of the camel.
- 3 Age a camel from its teeth.
- 4 Know the age of the llama and alpaca from the teeth.

The milk teeth of the camel

The camel has 22 milk teeth arranged as:

<b>Upper jaw</b>	<b>one front tooth on each side</b>	<b>2</b>
	<b>one canine (dog) tooth on each side</b>	<b>2</b>
	<b>three cheek teeth on each side</b>	<b>6</b>
<b>Lower jaw</b>	<b>three front teeth on each side</b>	<b>6</b>
	<b>one canine (dog) tooth on each side</b>	<b>2</b>
	<b>two cheek teeth on each side</b>	<b>4</b>

## Ageing camels from the milk teeth

<b>(1) New born:</b>	<b>There are no teeth.</b>	
<b>(2) One month:</b>	<b>Upper jaw:</b>	<b>2 cheek teeth on each side</b>
	<b>Lower jaw:</b>	<b>one cheek tooth on each side 2 front teeth</b>
<b>(3) Three months:</b>	<b>Upper jaw:</b>	<b>1 canine, 3 cheek teeth on each side</b>
	<b>Lower jaw:</b>	<b>3 front teeth, 1 canine, 2 cheek teeth on each side</b>
<b>(4) Six months:</b>	<b>Upper jaw:</b>	<b>1 front, 1 canine, 3 cheek teeth on each side</b>
	<b>Lower jaw:</b>	<b>3 front, 1 canine, 2 cheek teeth on each side</b>

## Ageing camels from the milk teeth

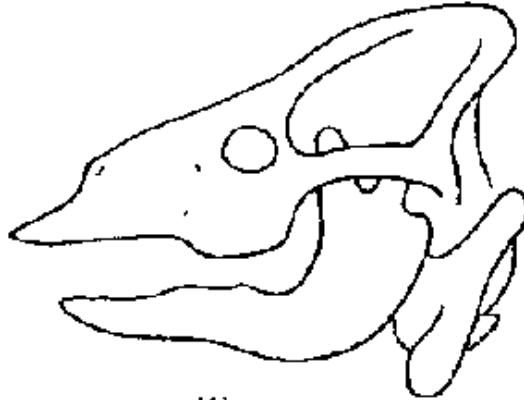

(1)

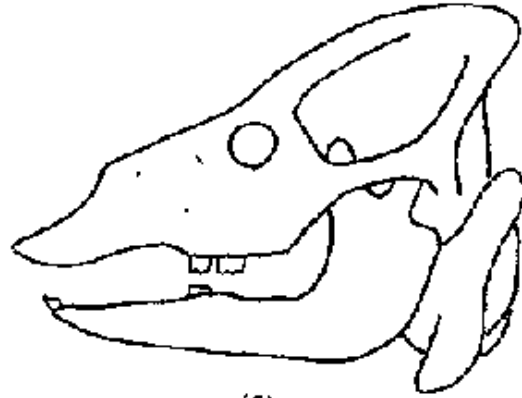

(2)



(3)

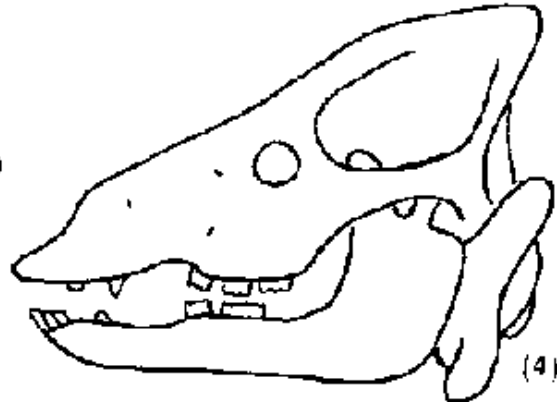

(4)

## The permanent teeth

**There are 34 permanent teeth. These are larger than the milk teeth and are arranged as follows:**

<b>Upper jaw</b>	<b>one front tooth on each side</b>	<b>2</b>
	<b>one canine on each side</b>	<b>2</b>
	<b>six cheek teeth on each side</b>	<b>12</b>
<b>Lower jaw</b>	<b>three front teeth on each side</b>	<b>6</b>
	<b>one canine on each side</b>	<b>2</b>
	<b>five cheek teeth on each side</b>	<b>10</b>

**Ageing camels after 1 year of age**

<b>1 year</b>	<b>Upper jaw:</b>	<b>4 cheek teeth on each side</b>
	<b>Lower jaw:</b>	<b>3 cheek teeth on each side</b>
<b>2.5 years</b>	<b>Upper jaw:</b>	<b>4 to 5 cheek teeth on each side</b>
	<b>Lower</b>	<b>3 to 4 cheek teeth on each side</b>

	<b>jaw:</b>	
<b>3 years</b>	<b>Upper jaw:</b>	<b>5 cheek teeth on each side</b>
	<b>Lower jaw:</b>	<b>4 cheek teeth on each side</b>
<b>4.5 years</b>	<b>First permanent front teeth are showing</b>	
<b>5 years</b>	<b>Milk cheek teeth replaced by permanent teeth, 2 replaced on each side of upper jaw, 1 on each side of lower jaw.</b>	
<b>5.5 years</b>	<b>2 more permanent front teeth on lower jaw</b>	
	<b>Upper jaw:</b>	<b>6 cheek teeth on each side</b>
	<b>Lower jaw:</b>	<b>5 cheek teeth on each side</b>
<b>6 years</b>	<b>Upper jaw:</b>	<b>1 front tooth and permanent canine through on each side</b>
	<b>Lower jaw:</b>	<b>permanent canine through</b>

<b>7</b>	<b>Full set of permanent teeth</b>
<b>years</b>	<b><i>First cheek teeth on both jaws are black</i></b>

The canines appear at 6 years of age and by the age of 7 are very large. These teeth in the upper jaw can be 4 centimetres long. The lower ones may be cut off by some camel owners. Camels can live to around 40 years of age but from 15 years of age they will have difficulty with hard feedstuffs as the front teeth wear and begin to spread.

### Ageing the llama and alpaca

It is difficult to age llamas and alpacas after 5 years of age. There are 32 permanent teeth. The first permanent cheek teeth appear at 6 to 9 months of age with another pair showing by 2 years of age. The first permanent front teeth appear at 2 years, the next at 3 years and the last pair at 3 to 6 years.

### Ageing camels after 1 year of age





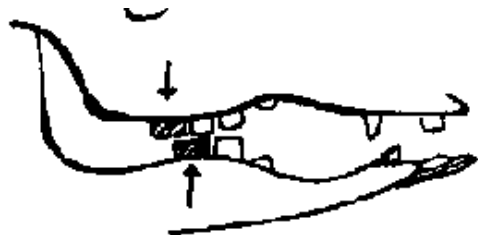

1 year



2.5 years



3 years



4.5 years

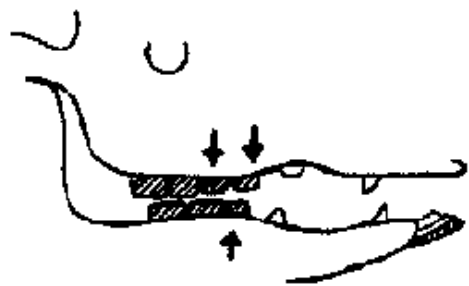

5 years



5.5 years

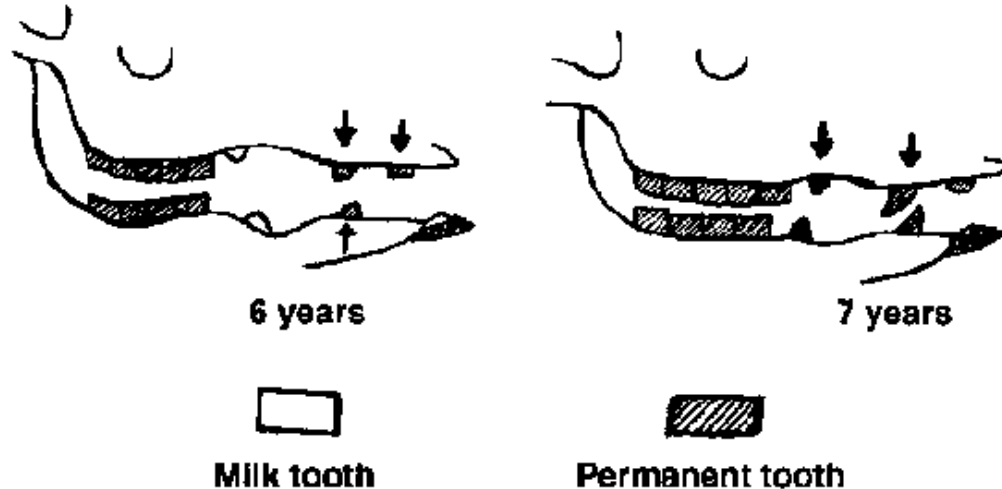

## Unit 59: Breeding camels

***The camel is unlike other animals as the female only has young every two years.***

***During the breeding season the male camels rut and become aggressive and dangerous.***

## **Learning objectives**

**After studying this unit you should know:**

- 1 Rutting in the male camel.**
- 2 Heat (oestrus) in the camel.**
- 3 Pregnancy in camels.**
- 4 Giving birth (parturition) in camels.**

### **Rutting in the male camel**

**The male camel becomes mature and will mate at 6 years of age. There is a breeding season (time) when mating takes place. The breeding season depends on availability of pasture, rain and cold and will vary from region to region. The male and female camels become restless and difficult to handle in the breeding season.**

**During the breeding season the male ruts. The signs of rutting are:**

- The back portion of the roof of the mouth is pushed out of the mouth like a pink ball (this only occurs in the**

**one-humped camel).**

- **The testicles become bigger.**
- **Glands on the neck behind the head begin to produce a brown, bad smelling matter.**
- **The animal will spread out its back legs and using the tail sprays urine over its back legs.**

## **Rutting**



**The male becomes difficult to handle and dangerous when rutting. It will attack other animals and people. Some animals, especially older males, constantly rut and become a problem. Such animals should be castrated and if there are any male animals that will not be needed for breeding they should be castrated at an early age. Ask your veterinary officer to castrate these animals.**

## **Heat (oestrus) in camels**

**The female comes into heat for the first time when she is 3 to 4 years old. The camel can continue to breed until she is 20 to 30 years old.**

**The female will show a desire for mating over a 3 to 4 day period during the breeding season. If she does not become pregnant she will come into heat again every 28 days and will have 5 periods of heat in any breeding season.**

**The signs of heat in the female camel are:**

- **She becomes restless and separates from the other animals.**
- **Sprays urine using the tail.**
- **The vulva becomes wet and swollen.**

## **Mating or mounting**

**The male mates with the female when she is kneeling on all four legs. Mating (or mounting) takes 10 to 20 minutes. It is advisable**

**to help a young inexperienced male to enter the female.**

## **Mating or mounting**

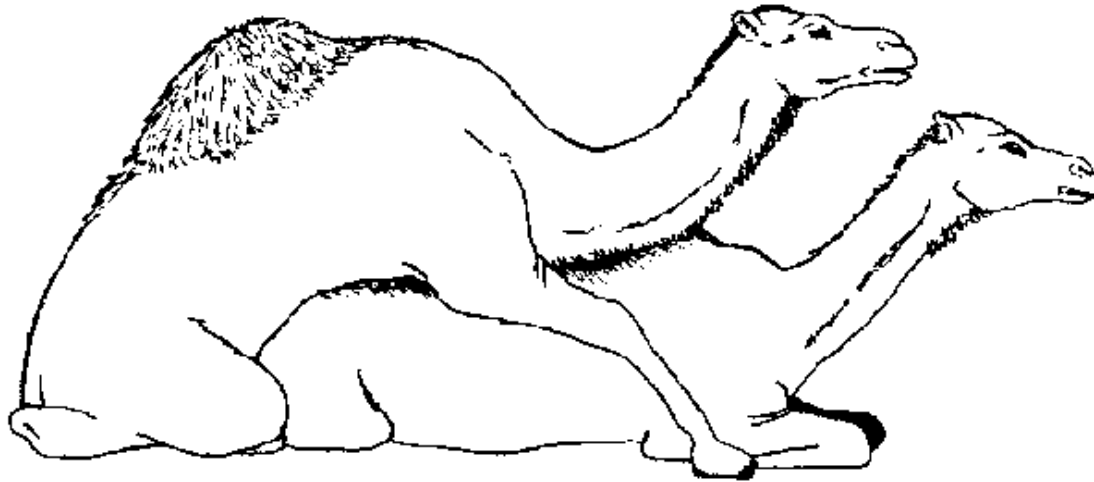

**One male will usually be mated with 5 to 7 animals although good males will mate with more than this and can mate with up to 70 females in one season. In one day a good male can mate two to three times with up to three females.**

## **Pregnancy**

**When a female camel is pregnant she will run away from any male which approaches her. After 3 to 4 months or more of the pregnancy your veterinary officer will be able to check the female internally.**

**Pregnancy lasts 390 days in the one-humped camel and lasts 406 days in the two-humped camel.**

**If there is plenty of feed available the young camel can be taken from its mother at 6 weeks of age and she can be mated again to produce young the next year. However productivity is low for most camels and they usually produce one young every two years.**

### **Giving birth (parturition) in camels**

**The signs that the female is about to give birth are similar to those in other ruminants. The female becomes restless, the vulva is swollen and she will separate from the other animals. Birth commences with the appearance of the water bag followed by the two front legs and the head.**



**The size of the newborn camel is dependent on the size of its parents. The average calf weighs around 35 kilograms and the male is larger than the female. The camel born in dry (bad) years will weigh less than the young animal born in a good year.**

**The mother does not bite through the navel cord neither does she lick and clean her baby, but she will help the young to find the teats to take milk. The camel is a very good mother and does not like anyone to go near her young.**

**If the female loses her young she will become very distressed. In order to keep the female producing milk the skin should be taken from the young camel and stuffed with straw. The female will continue to produce milk for her "baby".**

**Neither the one-humped or the two-humped camel will accept orphaned young. Orphans will have to be reared by hand.**

**In llamas and alpacas pregnancy lasts for about 1 year. Both the llama and alpaca will easily accept any young animal and foster it with no difficulties at all.**

## **Unit 60: Milk and care of the young camel**

***Young camels start to eat grass at 2 to 3 months of age and can be weaned by 4 months of age.***

***Leaving the calf to suckle for longer than this reduces the amount of milk available for people.***

### **Learning objectives**

**After studying this unit you should know:**

- 1 The production of young from the camel.**
- 2 The importance of colostrum.**
- 3 When to wean the young camel.**
- 4 Milk yield and quality.**

### **The production of young from the camel**

**A female camel will usually give birth to one young every 2 years. This means that a female will normally produce 8 young throughout her life. This is a very poor rate of reproduction.**

## **Many young camels die before or soon after birth because:**

- **The mother was not fed well during pregnancy.**
- **Some camel owners do not allow the calf to take colostrum.**
- **The male and female were related with perhaps the same mother and father. This is called inbreeding and will result in the production of dead or weak young in any type of animal. You should keep a record of the males used for breeding to try to avoid this happening.**

## **Colostrum**

**It is essential for the young camel to take colostrum from its mother in order to be protected against some diseases. The mother produces colostrum for 4 to 5 days after birth.**

**Many camel owners do not allow the young camel to freely suckle because they believe this causes the young to suffer from belly**

**pain and diarrhoea. Some owners will prevent the young camel from taking any colostrum and this can lead to its death. You should allow the young animal to take colostrum.**

## **When to wean the young camel**

**The young camel will start to eat grass when it is 2 to 3 months old and can be weaned when it is 4 months old. Many owners leave the young camel with its mother until it is at least a year old. If it is weaned early care must be taken to introduce it slowly to solid food in order to avoid diarrhoea developing and also to prevent it picking up internal parasites.**

**There are two methods used to prevent the young camel from taking milk from its mother:**

- **The udder is covered with cloths which are held in place by ropes passed over the back of the mother.**
- **A cord or rope is tied around the teat.**

**Tying the teat is not a good practice as it can result in damage to**

**the teat and the development of mastitis (disease of the udder).**

### **Milk yield and quality**

**If the young camel is allowed to suckle from its mother for 1 to 2 years the amount of milk available to the owner is reduced. If it is not allowed to suckle whenever it wants, milk can be taken from the mother and the young animal can be gradually weaned to solid food. A young camel that is allowed to take milk whenever it wants becomes fat and may have difficulty in walking. It will also suffer when it is finally taken from its mother.**

**The camel can produce milk for 9 to 18 months. Camel milk contains the necessary proteins, sugars, fats, minerals and vitamins for the young and is a valuable food for people.**

**The quality and quantity of milk produced by the camel will depend on the availability of water and feed, how often she is milked and when she gave birth. A camel will give 4 to 12 kilograms of milk daily. The milk will be sweet or salty in taste depending on the plants the animal feeds on.**

**Camel milk is a rich source of vitamin C and forms an important source of this vitamin for desert people who are unable get this vital vitamin from fruits and vegetables.**

**Camel milk may be the only available milk in desert conditions where other milking animals cannot be maintained. In some countries camels are kept for their milk which is not only used for drinking but can be made into a number of foods. If camel milk is mixed with the milk of other animals e.g. cow, goat, it can be made into cheese, yoghurt and butter. Milk from the two-humped camel is used for cheese and butter.**

### **Unit 61: Feeding and watering of camels**

***Camels can eat hard and thorny plants which can not be eaten by other animals.***

***Camels can stand thirst for a very long period.***

### **Learning objectives**

## **After studying this unit you should know:**

- 1 What plants and feed camels can eat.**
- 2 How much water camels need.**
- 3 How much salt camels need.**

## **Feeding camels**

**Camels are like goats and can browse, eating bushes and the branches of trees. Like cattle and sheep they also graze on grass. The camel browses or grazes for 8 hours each day and will take another 6 to 8 hours to chew the cud. They can be fed like cattle and will eat straw, hay, silage, grains and cakes.**

**The camel can eat sharp, thorny plants which other animals cannot eat. Camels can reach branches of trees and bushes to a height of 3 metres. The camel eats these woody plants by using its strong canine (dog) teeth to crush the wood.**

**In dry seasons when feed becomes scarce the camel can live off the fat which is stored in the hump. It can survive in this way for a very long period and will lose weight as the fat is used. A camel**

**can lose up to 200 kg in weight during this period.**

**Camels recognise poisonous plants growing in the area and will not eat them. However if the camel is moved to a new area where different poisonous plants are found then it may eat those plants.**

## **Water**

**The camel is well known for its ability to withstand thirst and to go without water for a long time. The camel can do this because:**

- **It can change its body temperature to as low as 34°C and as high as 41°C**
- **Camels produce small amounts of urine which is (concentrated) thick**

**If the camel is kept near a water point or a river it may drink small amounts of water daily. In cold weather, and when green feed is available, the camel may not drink water for months because it can get all the water it needs from the plants.**

**In dry seasons camels drink up to 60 litres of water every 10**



**days. A thirsty camel in a hot dry season can drink up to 200 litres of water in one go.**

## **Salt**

**Salt is very important for the camel. It needs eight times as much salt as do cattle and sheep. A camel needs 1 kg of salt a week and it is advisable to leave salt with camels every week.**

## **Unit 62: Surra of camels (trypanosomiasis)**

***A well kept and well fed camel will rarely suffer health problems which the owner is unable to deal with.***

***Surra (trypanosomiasis) is one of the diseases of camels for which you may need veterinary assistance.***

***You may need advice from the veterinary officer about treatment of the disease and he may need to take blood samples from the animal in order to check for the disease.***

## **Learning objectives**

## **After studying this unit you should know:**

- 1 What is surra.**
- 2 How does surra spread.**
- 3 What are the signs of the disease.**
- 4. Treatment and control of surra.**

### **What is surra?**

**Surra is a very common disease of camels and it has many different names in the areas of the world where it occurs. The disease is caused by very small parasites, called trypanosomes, which live in the blood of the animal.**

### **How surra spreads**

**The disease is spread by flies, e.g. horse flies, which bite the camel and carry the parasites from one animal to another. These flies cannot live where it is cold or dry and are found near water or around areas of dung. Camels should be kept away from such places especially when the flies are common after rain.**

## **Signs of the disease**

**All camel owners are familiar with this disease. Sick animals may develop a fever (see Unit 70) and do not eat. They are weak and the belly and legs become swollen. Pregnant animals can lose their young. If animals are not treated they can die within a few weeks of showing the first signs of infection.**

**Other animals may stay sick for many months or even years. They are weak and the hump becomes smaller and smaller. These animals can develop skin problems and most suffer from lung diseases. They will usually stand facing the sun.**

## **Treatment and control**

**If you believe that an animal in your community has surra you should immediately ask your veterinary officer to examine it. He will take blood smears and samples for checking. You may need to take blood samples yourself to send to a laboratory (see Annex 3).**

**There are a few drugs which can be used to treat surra, e.g.**

**Naganol, Antrycide (see R17 Annex 1). As surra is spread by biting flies camel owners need to know where and when these flies occur and to take precautions against them by:**

- **Seasonal movements of camels away from fly areas.**
- **Regular movements of camels to avoid flies hatching from the dung in which the maggots live.**
- **Watering animals in the hottest time of the day when few flies are found.**

**Do not treat camels for surra if they have had a large quantity of water following a long period without water. Treat them several days after drinking water or do not allow them to take too much water before treatment.**

### **Unit 63: Internal parasites of camels**

***The infernal parasites of the camel are similar to those of sheep and cattle.***

***Camels infected with infernal parasites are weak, have poor***

***appetite, may have diarrhoea and do not put on weight. Young animals will suffer the most from any parasite.***

## **Learning objectives**

**After studying this unit you should know:**

- 1 The internal parasites of camels.**
- 2 Problems caused by internal parasites.**
- 3 How to treat and control internal parasites.**

## **The parasites**

**Camels can be infected with different roundworms in the gut. These feed off the animal. Camels can also be infected with worms in the lungs and flukes (see Unit 15) which infect the liver.**

**When camels are slaughtered (killed) large cysts, fluid filled bags, may be found in the liver, lungs and other organs. These cysts contain many young tapeworms (see Unit 15) which will infect meat-eating animals.**

## **Problems caused by internal parasites**

**The parasites in the gut cause weight loss, weakness and may cause diarrhoea and death especially in the young animal. Lungworms will cause breathing problems and infected animals develop a short, sharp cough.**

**The tapeworm cysts which are found in the camel will develop into adult worms if eaten by dogs, foxes or wolves.**

**The cysts cause damage to the body organs of the camel. Cysts in the brain will result in the animal being unable to walk or eat properly. Infected animals walk in circles; they may also become blind. However the main problem is that humans can be infected as well as the camel (see Unit 79).**

## **Treatment and control of internal parasites**

**Drugs which are used to treat cattle infected with internal parasites (see R11 Annex 1) can be used to treat infections in camels.**

**If you notice a camel eating earth or chewing bones this is sign of worm infection of the stomach. The worms suck the blood of the camel and you should treat the animal immediately.**

**If you believe that there is a parasite problem in the camels in your community ask your veterinary officer for advice on which drug to use to deal with the problem.**

**In order to prevent infection of the camel with parasites in the gut or lungs, do not allow it to graze in wet areas around water holes which are used by many animals. The eggs of most parasites will be found in such areas.**

**If you find cysts in organs, such as the liver or lungs, of animals which have been killed for meat, it is best not to use the organ for meat. Do not throw it away because if it is eaten by dogs, foxes or cats the disease will spread. You should bury any infected organs in a deep hole, burn the infected organs or put them in a barrel half filled with water and salt. Very salty water will kill young tapeworms in the cysts.**

## **Unit 64: Skin diseases of camels**

***Infections of the skin caused by parasites are a big problem in camels. Camels can be infected by ticks and mites, and suffer from fly maggots feeding on wounds and in the nose.***

***If it is not treated mange (mite infection) can lead to the death of a camel. Mange is very infectious and is second to surra in causing problems and losses in camels.***

***Mange also results in the loss of valuable wool from llamas and alpacas.***

### **Learning objectives**

**After studying this unit you should know:**

- 1 Skin diseases of camels.**
- 2 The problems caused by skin diseases.**
- 3 How to treat and control skin diseases in camels.**

### **Skin infections of camels**



**Camels suffer from infections with mites and ticks, and the maggots of flies which feed on open wounds or live in the nose.**

**Mites cause mange and infections often start on the neck, head or underbelly of the animal but will rapidly spread to cover the entire body if not treated.**

**Camels can be attacked by many different ticks. Ticks will usually be found attached to the legs, head and the underbelly.**

**If wounds are left untreated they will become infected with the maggots of different flies which feed on the blood and meat. The camel is also infected by maggots of the camel nasal fly. The fly lays its eggs around the nose of the camel and the maggots, which grow to about 1 centimetre long, hatch and feed on the inside of the animal's nose.**

**Ringworm infections cause roundish, white spots on the head, neck and other parts of the body.**

**Mange in the camel**

**Mange in camels, like surra, is a very important disease and is very infectious. Camels are infected by contact with infected animals, from mites on saddles and other equipment, and by rolling in dust where infected animals have been. Humans can also become infected.**

**The mange mite burrows into the skin and causes loss of hair and the skin becomes thick and white. Infection often starts on the head or neck, but if not quickly treated it will spread over the entire body in 2 to 3 weeks. Infected animals scratch against any solid object and do not eat well. Weight loss occurs, milk production drops and animals can die. The infection is more common in colder months and when feed is scarce.**

**Infections with mange must be treated quickly. If there is mange in camels in your community you should immediately ask your veterinary officer for advice on what drug (see R15 Annex 1) you should use. Treatment will involve washing or spraying the infected areas.**

**To prevent the infection from spreading saddles and other**

**equipment should be thoroughly cleaned, or even burned. Your veterinary officer may advise that other animals in the community are treated even if they are not showing signs of the infection. Remember that humans can be infected with the mite and always wash hands thoroughly after handling camels.**

## **Tick infections and their control**

**Tick infections are common. They result in:**

- **Swellings and small wounds in the skin from the bites.**
- **The tick feeds on blood and infections result in loss of blood, weight loss and weakening of the animal.**
- **Ticks can spread other diseases.**
- **Poisons from some ticks affect the nervous system and muscles and the animal cannot move (paralysis) which can lead to death.**
- **Tick infections can cause the death of young camels.**

**Tick paralysis is caused by the bite of some ticks. The camel suddenly shows signs of paralysis and its body temperature will drop. The poisons can affect respiration and the camel stops breathing and dies.**

**Ticks are killed by spraying, removing by hand or applying kerosene or a lighted cigarette to the back of the tick. Infections can be controlled by pasture rotation (see Unit 16). Tick paralysis can be caused by the bite of a single tick. The only treatment for paralysis is to quickly find and remove the tick. If this is done quickly enough the animal will eventually recover.**

### **Problems caused by fly maggots**

**Fly maggots can prevent healing of wounds and other germs may infect the wound. The maggots of the camel nasal fly are usually seen in the spring and summer. There is a discharge from the nose and the animal may sneeze. Camels are not usually seriously affected by the maggots but the activity of the adult flies trying to lay eggs is annoying.**

**Maggots should be removed from wounds and the wound properly cleaned and dressed (see Unit 73). The maggots of the nasal fly can be killed by giving injections of nitroxylnil (see R11 Annex 1) but this need only be done if your veterinary officer advises it.**

### **Ringworm infection of the camel**

**Ringworm infection in camels is similar to that in other animals (see Unit 16). It is infectious and will spread to other animals and can infect humans.**

**Ringworm is treated by applying tincture of iodine. You should ask your veterinary officer for advice. He will take skin scrapings to discover if the problem is caused by mange or ringworm. He may advise the use of other drugs if they are available (see R25 Annex 1).**

### **Unit 65: Foot problems in camels**

***The camel's foot is adapted for sandy soils and can be described***

***as a tyre filled with fat instead of air.***

***In these days the camel walks on tarred, hard surfaced roads and ground which is littered with sharp objects such as nails, wire and broken glass. These may cause damage to the foot and result in lameness.***

***Llamas and the alpaca have two toes on the foot with toe nails which vow like the hoof of sheen and gnats.***

## **Learning objectives**

**After studying this unit you will know:**

- 1 The structure of the camel's foot.**
- 2 Care of the camel's foot.**
- 3 The foot of the llama and alpaca.**

## **The foot of the camel**

**The camel's foot is flat and soft and divided into two. There is a toe nail at the end of each side.**

## The foot of the camel

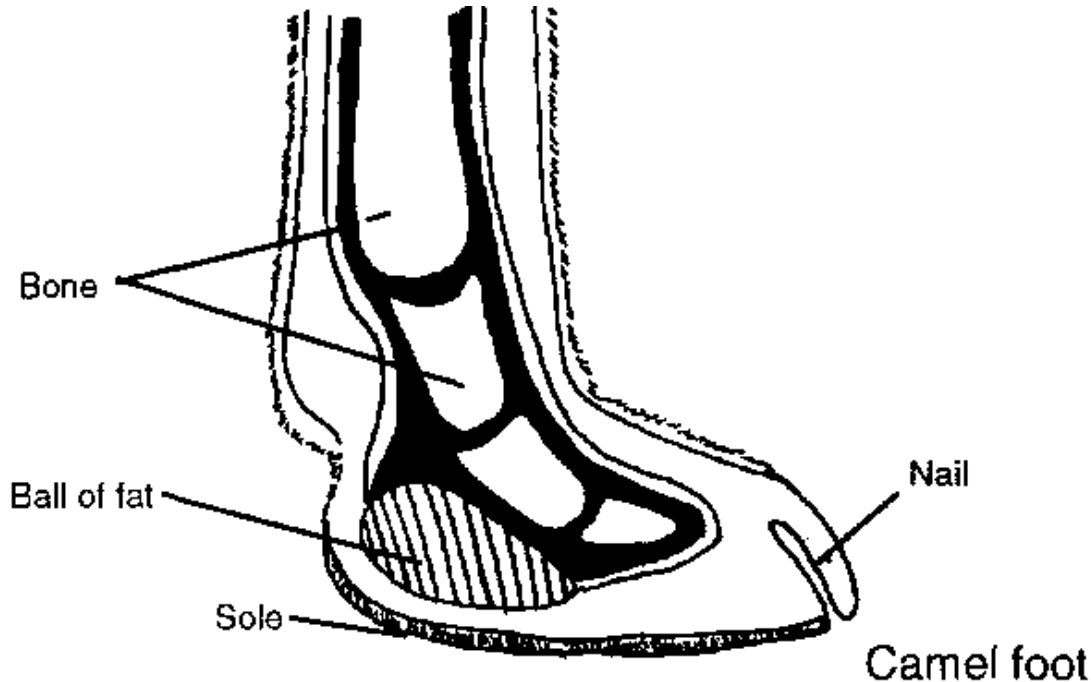

**Sharp objects such as nails, wire, glass and thorns penetrate the sole of the foot causing wounds. The pain from the wound can make the animal lame. Sometimes the foot swells from walking on**

## **hard roads.**

**Simple wounds can be treated with tincture of iodine (see Unit 73). If severe lameness occurs you must ask your veterinary officer for advice on treatment.**

**Sometimes the camel's foot can be covered with thick cloth or leather to stop the swelling becoming worse.**

## **Feet of the llama and alpaca**

**The foot of the llama and alpaca is divided into two and each half has a toenail which grows like the hoof of sheep and goats. You can use the same tools for foot care of the llama and alpaca as are used for the feet of sheep and goats. The toenails of these animals can be trimmed**

## **Feet of the llama and alpaca**





Good foot

Bad foot



## Chapter 8: The rabbit

---

[Unit 66: Breeding and feeding rabbits](#)

[Unit 67: Health problems of rabbits](#)

---

### Unit 66: Breeding and feeding rabbits

***Rabbits are easy to house, cheap to feed and produce a very good quality meat.***

***One male rabbit (buck) and two females (does) given care and good feeding, will produce more than 50 rabbits a year. This means you can sell or eat almost one rabbit every week of the year.***

### Learning objectives

**After studying this unit you should know:**

#### **1 Breeding rabbits.**

- 2 Care of young rabbits.**
- 3 Housing (hutches) for rabbits.**
- 4 Feed and water for rabbits.**
- 5 Uses of rabbits.**

## **Breeding rabbits**

**The female rabbit (doe) does not come into heat (oestrus) as do other animals. The doe will accept the male (buck) at any time of the year.**

**Does are mature and can breed at 5 to 6 months of age and can continue to have young for 4 years.**

**The length of pregnancy in the rabbit is 31 days and the doe can produce from 1 to 12 young each time she gives birth. She can become pregnant again within a few days of giving birth. However it is not good practice to allow the doe to become pregnant straight after giving birth. It is better to mate the doe when her young (litter) are 4 weeks old so that they are 8 weeks old when the next litter is born. In this way one doe can produce 6 litters a**

**year.**

**Two weeks after mating you can feel the young through the side of the doe's belly.**

**Male rabbit (buck)**

**Traditionally people keep all their rabbits together. However it is advisable to keep the buck separate from the does and do not keep bucks together as they will fight. The doe must be taken to the buck for mating and then returned to her place. A buck can be used until he is 7 years old. If you have large numbers of rabbits together use one buck with every 15 does.**

**Giving birth and care of the young rabbit**

**The doe needs a nest in which to give birth. She will line the nest with her fur. Do not check the young until the day after birth and do not touch them with your hand. Use a stick to gently touch them when checking and remove any that are dead. They are blind until the eyes open at 10 days of age.**

**Leave the young rabbits with the mother. They can be killed for meat from 3 months of age.**

## **Sexing rabbits (knowing the sex)**

**Knowing what sex the young rabbits are is important because you may want to keep the does and sell or kill the bucks. To sex young animals you look at the area below the anus. In old bucks the scrotum can clearly be seen.**

## **[Sexing rabbits \(knowing the sex\)](#)**

## **Feeding rabbits**

**You can buy ready-mixed rabbit feed (pellets) made from grain, plants, minerals and vitamins. However this may be expensive or not available. Rabbits can be fed the following:**

- **Vegetables such as carrots, sugar beet, manger beet, parsnip, swede, turnip, potato and other root vegetables**
- **Green leaves**

- **Grains such as oats, wheat, barley and maize**
- **Dry bread**
- **The waste skins or tops of vegetables from the kitchen**
- **Dry sunflower heads (the rabbit will eat the seed)**
- **Young branches from trees such as acacia**
- **Bran mash (bran is produced from the milling of wheat or rice)**

### **Feeding during the dry season**

**As with other animals you must think about what to feed rabbits during the dry season. The following can provide for dry season feeding:**

- **Hay, preferably from green leafy plants. Bind the plants into bundles and hang them to dry in the wind but avoid putting them in the direct sun. This type of hay is**

**preferable to that made from sun-dried grasses (see Unit 23).**

- **Carrots, beetroot, turnips and other root vegetables can be kept for a long time in dry sand in a bin, barrel or wooden box. Arrange the vegetables in layers separated by dry sand and cover the top with a layer of straw. Another way to keep root vegetables is to place the vegetables in layers with straw between them. The whole pile is covered with straw and then earth. Leave a small hole at the top for ventilation**

### **Feeding during the dry season**

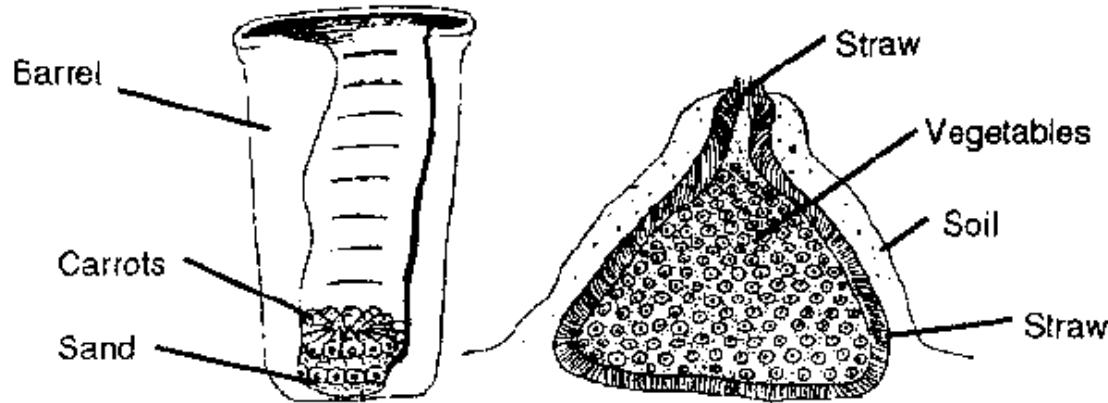

## Eating the droppings (faeces)

Rabbits produce both hard and soft droppings. It is natural for the rabbit to eat the soft droppings it produces because they contain nutrients and water. When the soft droppings pass through the gut for a second time the nutrients and water can be absorbed (taken into the body). The droppings produced then will be hard.

## Water for rabbits



**A supply of drinking water is necessary at all times. A suitable water drinker can be made from any plastic bottle. Make one or two holes in the bottom of the cleaned bottle, fill it with water and screw on the top. Place this in a shallow container. This could be used for water for chickens too.**

### Water for rabbits

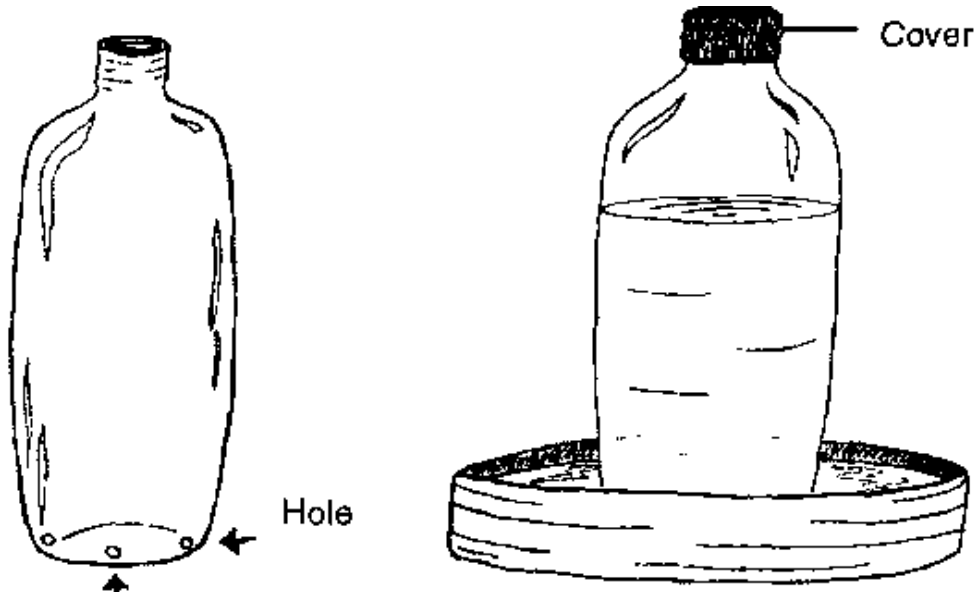

## **Housing rabbits**

**A small wooden house (hutch) will be sufficient for a buck. You can make hutches to contain more than one rabbit. The hutch must be clean, dry and well ventilated.**

**Remember that rabbits can be difficult to keep in runs (fenced areas) as they will burrow down and under a fence and escape. They can be kept in enclosed areas if the fencing material is partly buried to stop them burrowing under it.**

## **Housing rabbits**

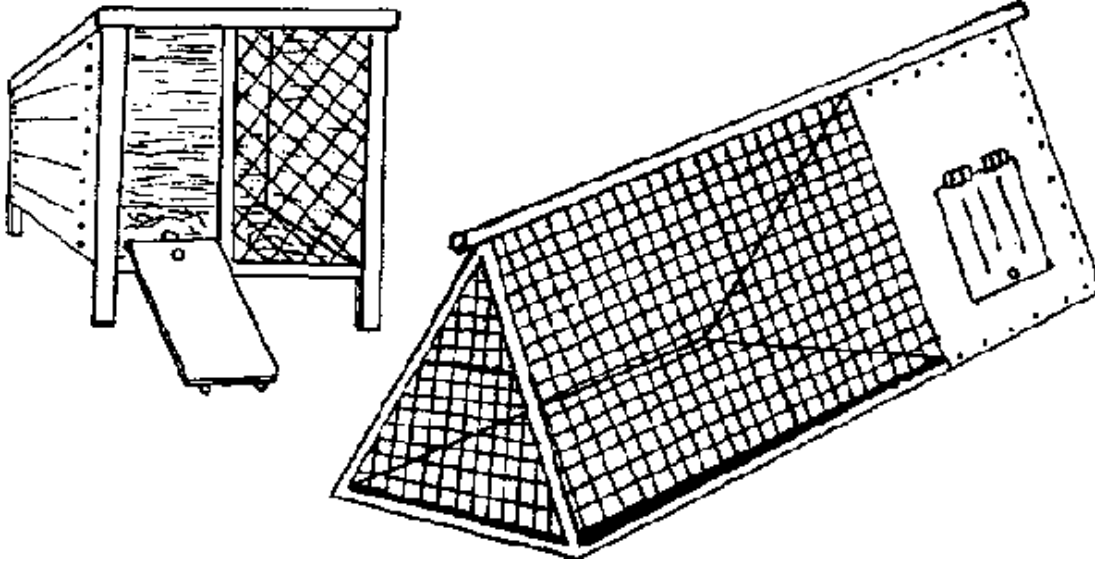

## Nesting box

**This is nothing more than a cardboard or wooden box or even a basket. It is open only at the top so the mother cannot take the young out of the nest. The nest box should be lined with hay. By the time they are 3 weeks old the young will come out of the nest themselves.**

## Nesting box

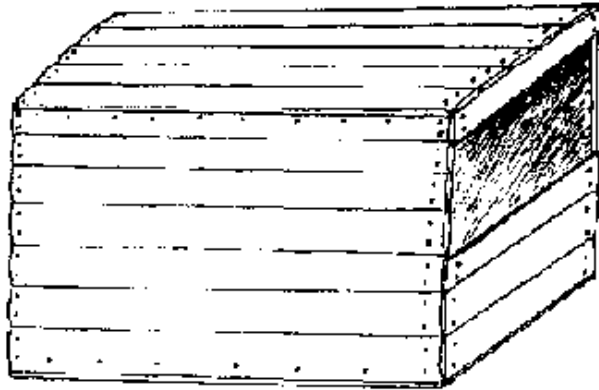

Wood

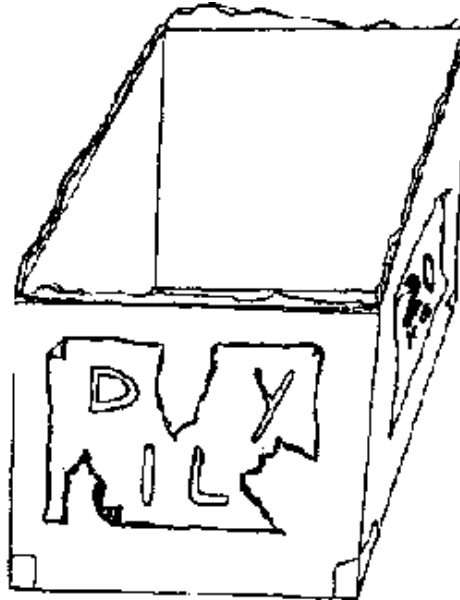

Cardboard box

### Uses of rabbits

**Rabbit meat contains little fat. It is white in colour and is very nutritious as it contains a lot of protein. Like a chicken, one rabbit will provide enough meat for a family meal.**

**Some breeds of rabbit have long hair which is collected and spun to give wool for clothing. Rabbit skins can be dried and treated to give good pelts (skins with fur) to be used in clothing and other uses.**

**Rabbit droppings make excellent fertiliser. They contain more nutrients for plants than droppings from other animals and are useful fertiliser for growing vegetables.**

## **Unit 67: Health problems of rabbits**

***It is better to prevent disease in rabbits rather than to have to cure disease. Good feeding and clean housing will guarantee disease free rabbits.***

***It is easy to recognise a sick rabbit as:***

- the eye will be dull***
- the coat is rough***
- there will be diarrhoea***
- it sits in a corner grinding its teeth***

***Taking the body temperature will show if the rabbit is sick. The normal temperature of a rabbit is 39.3° C.***

## **Learning objectives**

**After studying this unit you should know:**

- 1 How to handle rabbits.**
- 2 Ear problems in rabbits.**
- 3 Problems with the teeth and toes in rabbits.**
- 4 Problems caused by parasites.**

## **Handling rabbits**

**To pick up a rabbit put one hand around the bottom of the ears to control the animal and hold the loose skin on the back of the neck. Use the other hand to take the whole weight of the rabbit.**

## **Handling rabbits**

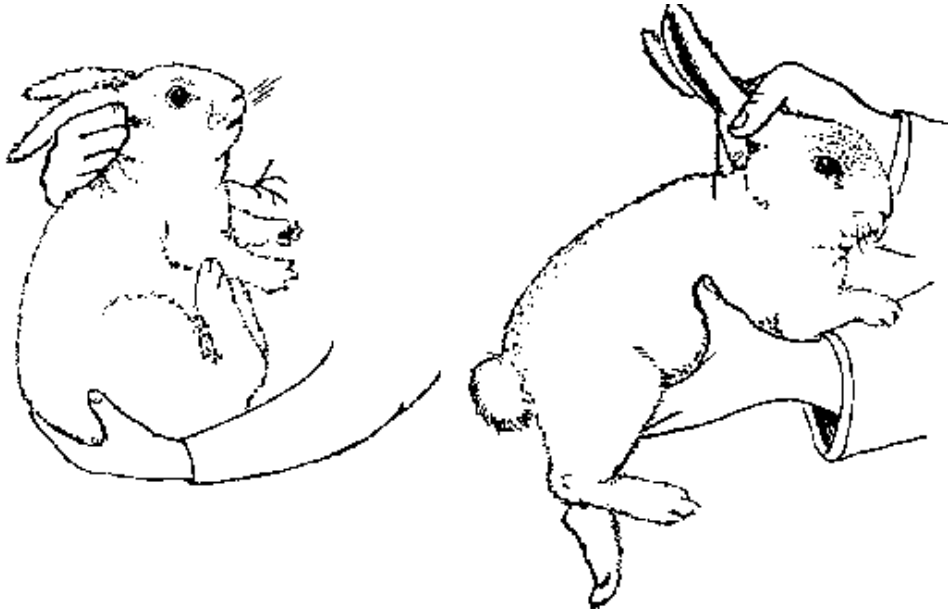

### **Ear mange (ear canker)**

**This is a very common disease of the ear. It is caused by mites, small parasites which burrow into the skin of the ear canal (inside ear).**

**The rabbit shakes its head from side to side and rubs its ears**

**against the cage and walls. A yellowish white crust (thick layer) covers the ear canal.**

**The easiest way to treat this infection is to put a few drops of oil (olive, sesame or sunflower) inside the ear and massage it. Repeat this every day until the condition improves. If you have any powder for ticks and mites you can mix a little with the oil and use it (see R24 Annex 1). See your veterinary officer if the disease continues.**

**Cages and houses should be kept clean. Wash your hands when you treat a rabbit and before you touch other animals.**

### **Overgrown nails and teeth**

**The rabbit's nails grow continuously and can sometimes become overgrown. They can be clipped back using nail clippers or pliers. Do not cut too close to the foot.**

**Rabbits have four front teeth in the upper jaw and two in the lower jaw. The teeth grow continuously but as the animal eats they are worn down. Sometimes the lower and upper teeth do not**



**meet when the mouth is shut. The teeth in this case do not wear down. You will need to cut them with a wire cutter or a pair of pliers.**

## **Overgrown nails and teeth**

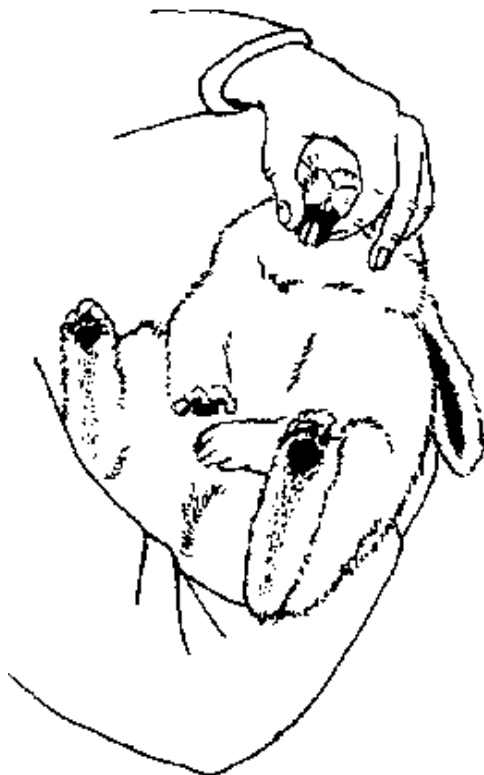

Checking teeth

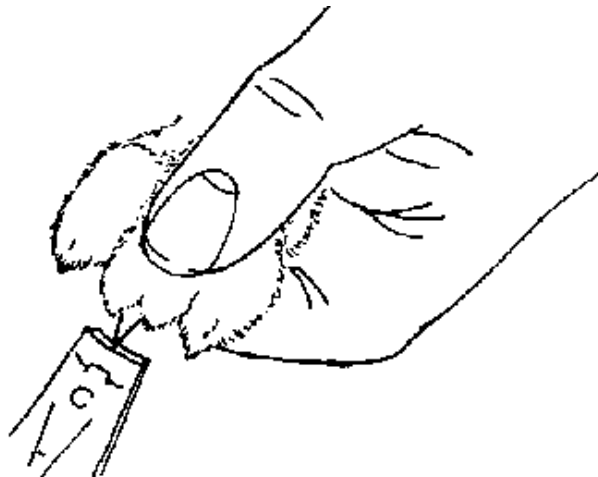

Clipping nails

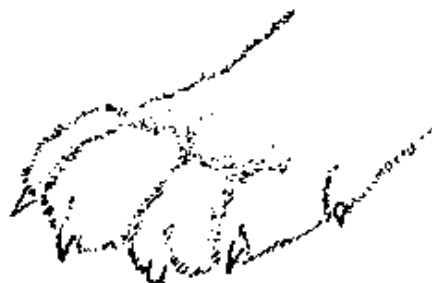

## Problems caused by parasites

**Rabbits suffer from fleas which suck the blood and carry disease. Fleas lay their eggs in the cracks and holes in the walls of the housing. Rabbits can be treated with a dusting powder (see R 15 Annex 1) against fleas and the housing should also be thoroughly cleaned and dusted.**

**Coccidia (very small parasites) in the liver and gut can be a problem especially in animals under 4 months old. They cause diarrhoea which may contain blood and animals lose weight and are pot-bellied. Coccidia can kill many rabbits.**

**The parasites live in the droppings so hutches and cages should always be kept clean. One teaspoon (5 ml) of iodine in 5 litres of drinking water can be used to help prevent this disease. It should be given to the female rabbit before her young are born.**

***Rabbits can also suffer from diarrhoea, constipation, abscesses, mastitis and eye infections. Your veterinary officer can advise you about these problems in your rabbits.***

---



---

## Chapter 9: Treating sick animals in general

---

[Unit 68: Diarrhoea and constipation](#)

[Unit 69: Salivation and mouth problems](#)

[Unit 70: Fever](#)

[Unit 71: Coughing and breathing problems](#)

[Unit 72: Eye problems](#)

[Unit 73: Wounds and bleeding](#)

[Unit 74: Fractures \(broken bones\)](#)

[Unit 75: Lumps under the skin](#)

[Unit 76: Poisoning](#)

---

### Unit 68: Diarrhoea and constipation

***When an animal passes watery droppings many times a day it has diarrhoea.***

***Animals with diarrhoea lose water and salt from their bodies. They become weak, thin and can die. It is common in young animals and kills many.***

***Constipation occurs when the animal cannot defecate or it passes droppings with difficulty.***

## **Learning objectives**

**After studying this unit you should know:**

- 1 How to recognise diarrhoea and constipation.**
- 2 What causes diarrhoea and constipation.**
- 3 Diarrhoea in different animals.**
- 4 Treatment and control of diarrhoea.**
- 5 Treatment of constipation.**

## **Recognising diarrhoea**

**Diarrhoea is a condition in which animals pass watery droppings (faeces) many times a day. The droppings are loose, runny and smelly and are a different colour from normal. Droppings can become dark green, dark brown or reddish black in colour because of blood in it. In some cases, e.g. rinderpest, the animal has diarrhoea which has a very bad smell.**

### **Causes of diarrhoea**

**Diarrhoea may continue for one or two days and then stop. This type of diarrhoea is caused by:**

- **The wrong feed was given to the animal.**
- **A sudden change in the animal's feed.**
- **Feeding silage can sometimes cause diarrhoea.**
- **Feed was old, rotting or fermenting.**
- **Diarrhoea can be caused by germs (a high body temperature may occur).**
- **Infection with parasites can cause diarrhoea which sometimes contains blood.**

## **Diarrhoea in ruminants**

**Diarrhoea in cattle, sheep, goats and buffaloes can be caused by:**

- **Germs and internal parasites, especially in young animals on pasture.**
- **Germs infecting the intestines of young animals (body temperature not usually elevated).**
- **Overfeeding calves with poor quality powdered milk**

***If cattle have diarrhoea and also have mouth lesions (not normal) you must ask your veterinarian for advice.***

**Diarrhoea in sheep and goats can result from:**

- **Infection with a germ (body temperature may be elevated).**
- **Internal parasites in young animals on pasture.**

***Young animals can show diarrhoea after weaning.***

## **Diarrhoea in horses**

**This can be caused by:**

- **Infection with germs (body temperature usually is elevated).**
- **Antibiotics or drugs which were given for another problem.**
- **Stress conditions (animal is not well kept and is disturbed) can result in diarrhoea.**
- **A one week old foal may develop diarrhoea when its mother comes into heat (oestrus).**

**Diarrhoea in pigs**

- **Diarrhoea in the pig can be caused by infection with germs (body temperature may be elevated) and internal parasites.**

**Diarrhoea in camels****This can be the result of:**



- **Too much fresh green feed causing green diarrhoea.**
- **Parasites infecting the animal causing dark brown or dark red diarrhoea.**
- **Male camels in the rut can have diarrhoea.**

### **Diarrhoea in chickens and ducks**

- **White diarrhoea disease of chickens is caused by a germ (bacteria) which passes from the mother to her young. In adult birds it causes greenish-brown diarrhoea but in the young bird the diarrhoea is white in colour.**
- **Diarrhoea containing blood can be caused by the small parasites called coccidia (see Unit 55) which infect the gut.**

### **Diarrhoea in rabbits**

**The rabbit's droppings should be separate, round, fairly firm and greyish brown in colour. Any change is a sign of a health problem. Diarrhoea can be caused by:**

- **Changing the feed from dry to green feed.**
- **Bad feed, either too wet, too cold or contaminated with chemicals.**
- **Disease caused by germs (body temperature will usually be elevated).**
- **Coccidia can cause diarrhoea in young animals.**

## **Treatment**

**Diarrhoea accompanied by fever is caused by germs. If the diarrhoea continues for more than two days and the body temperature has gone up (see Unit 4) you should ask your veterinarian for help. The animal may be treated with antibiotics (see R6, R7 Annex 1) or by sulpha drugs (see R9 Annex 1).**

**Diarrhoea will cause the animal to lose water and salts and if this is allowed to continue the animal can die. If you cannot get veterinary help you can give the animal a home treatment of rehydration fluid. To make rehydration fluid mix six teaspoons of sugar and half a teaspoon of salt with 1 litre of clean, warm water. Give this as a drench (500 ml for sheep or goats) four**

**times a day for 3 days. Larger animals require more fluid, 5% of body weight 2 times per day.**

### Treatment

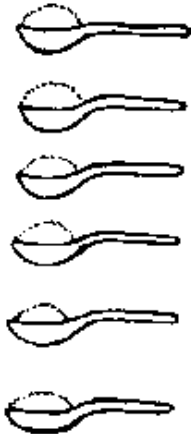

Sugar



Salt



Water

### Constipation

**Constipated animals cannot defecate or they pass very hard**

**droppings with difficulty. The animal with constipation is easy to spot.**

**Constipation is treated by giving an enema. Warm soapy water is injected into the rectum. Epsom salts or commercially produced oils (see R22 Annex 1) can be given by mouth to relieve constipation.**

## **Constipation**

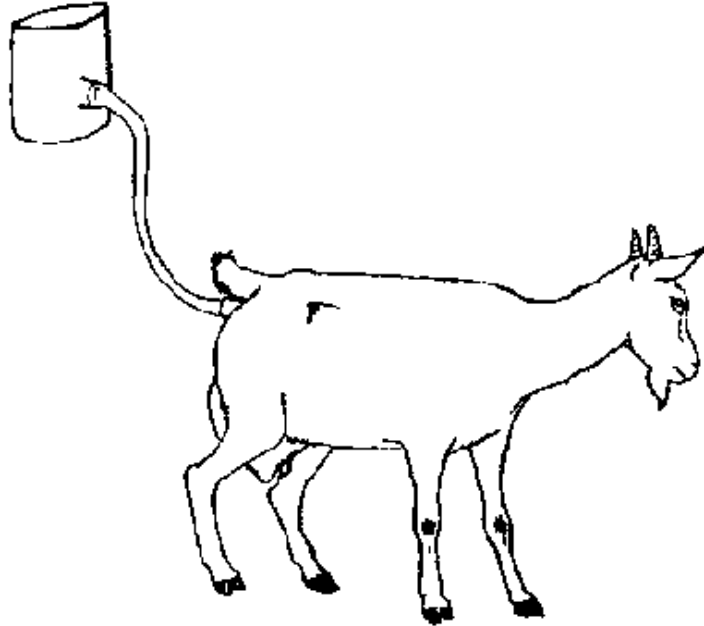

## Unit 69: Salivation and mouth problems

***Saliva is produced by glands in the mouth and helps in the chewing and swallowing of food.***

***Excessive salivation, when saliva shows as dripping, threads or***

***froth around the mouth, is not normal.***

***Excessive salivation accompanied by mouth lesions and fever is a sign of disease.***

## **Learning objectives**

**After studying this unit you should know:**

- 1 Recognise excessive salivation.**
- 2 Recognise choking (feed stuck in the gullet).**
- 3 Know the types of mouth lesions.**
- 4 Blisters in the mouth.**
- 5 Treatment of mouth problems.**

## **Excessive salivation**

**Excessive salivation accompanied by chewing movements may be caused by a number of different things. Open the animal's mouth and check what is causing the problem. It may be due to:**

- Foreign bodies (thorns, nails, pieces of feed) in the**

**mouth or between the teeth**

- **Teeth problems and abscesses**
- **Poisoning**
- **Pieces of feed stuck in the oesophagus (gullet) causing choking**

**Choke (feed in the gullet)**

**This happens when large or dry pieces of feed become stuck in the gullet (oesophagus). It is common in cattle and can occur in horses. The obstruction must be removed.**

**Choke in ruminants causes bloat (tympany). The best way to remove the obstruction is to push upward toward the mouth from the outside on the left side of the neck.**

**Another way is to press hard on the top of the mouth with your fingers to make the animal open its mouth. Then pour a small amount (10 - 20 ml) of oil into the mouth of the animal or pass a stomach tube down the gullet (see Annex 3).**

## **Salivation accompanied by mouth lesions**

**Sometimes an animal produces excessive saliva which drips or froths from the mouth. This is because of a lesion in the mouth or on the tongue or lips. Mouth lesions can be:**

- **Red spots and blisters (watery fluid filled bags of skin) in the mouth**
- **The skin comes off from some areas leaving red tissue showing**
- **The tongue is swollen**

**Excessive salivation, mouth lesions and fever are signs of infectious disease and you should get your veterinary officer to look at the animal immediately.**

**Rinderpest and foot and mouth disease (see Unit 25) cause excess salivation and mouth lesions. Other diseases also cause these signs.**

**Dress lesions of the mouth with antiseptic (see R 3 Annex 1).**



**Your veterinarian may recommend antibiotic injections for several days**

## **Unit 70: Fever**

***It is important to know the body temperature when checking the health of an animal. Use your thermometer to take the body temperature if you think an animal is sick***

***If the body temperature is higher than normal (see Unit 4) the animal has a fever. Fever is one of the commonest signs of an infectious disease.***

***A small rise in body temperature is called a slight fever and a large rise is called a high fever. When the body temperature is lower than normal the animal has a subnormal temperature which could be caused by starvation, bleeding or dehydration.***

***Fever, like diarrhoea, causes the animal to lose a lot of water and salts from the body.***

## **Learning objectives**

**After studying this unit you should know:**

- 1 When an animal has fever.**
- 2 What causes fever.**
- 3 What to do with a fevered animal.**

## **Fever**

**You should know the appearance of the healthy animal (see unit 5). If you believe that an animal is not healthy, talk to the owner or keeper to discover all that you can about it. Examine the animal and use your thermometer to take the body temperature.**

**If the body temperature is higher than normal the animal has a fever. The increase in the temperature tells you how great a fever the animal has.**

**The normal body temperature of sheep is 39°C. If the temperature is 40°C or 41 °C then the sheep has a slight fever. If the temperature is from 41.5°C to 42°C then the animal has a high**

**fever. A temperature of 38°C is subnormal.**

**For all animals a rise of 1°C or 2 °C in body temperature is a slight fever while any temperature more than 2°C above normal is a high fever.**

### **The cause of fever**

**Fever, especially high fever, is the result of an infectious disease caused by germs (see Unit 6). When some types of germs get inside the body of an healthy animal, it will become sick. Animals can get germs from:**

- **Breathing in germs from the air.**
- **Dirty water and bad feed.**
- **Dirty animal housing from which droppings and urine have not been cleaned.**
- **Milk, saliva, urine or blood from sick animals.**
- **Fly bites and injuries.**

### **Treatment of fever**

**If an animal has a fever, separate it from the others and keep it in a shady, cool place with plenty of clean, fresh water. If the animal has a slight fever and shows no diarrhoea, constipation, discharge from the eye or mouth or any other signs of ill health, it should be given some good feed. Keep a check on it for a day or two to see if the fever drops.**

**If the animal has a high fever and diarrhoea, a discharge or other signs of ill health you should give it only clean fresh water and if possible get veterinary help. If you cannot get veterinary help for an animal with a high fever you can give it an antibiotic or sulpha drug by injection or by the mouth for at least three days to kill the germs (see R6, R7, R9, R10 Annex 1).**

**Watch closely for signs of improvement over the next two days. If the animal does not return to normal (eating, drinking and movement) you will have to contact the veterinarian to discover the problem and to how to treat it.**

## **Unit 71: Coughing and breathing problems**

***A cough is a strong forceful expiration (breathing out) through***

***A cough is a strong, forceful expiration (breathing out) through the mouth.***

***A sneeze is a short, forceful expiration through the nose.***

***Difficulties in breathing and very fast breathing are other problems of the respiratory system and are not normal conditions.***

***Breathing problems accompanied by fever and discharge from the nose are very bad signs and mean that the animal has an infection.***

## **Learning objectives**

**After studying this unit you should know:**

- 1 When an animal has a cough.**
- 2 Sneezing.**
- 3 Discharge from the nose.**
- 4 Treating animals with respiratory problems.**

## **Coughing**

**A cough is a strong forceful expiration (see Unit 3). Coughing is caused by:**

- **Infectious diseases of the lung or windpipe.**
- **Parasites in the lung.**
- **Fluid or mucous in the lung or windpipe.**
- **A medicine (drench) going into the lungs instead of through the gullet to the stomach.**

**Pigs can cough as a result of being given dusty (powdery) feed.**

## **Sneezing**

**A sneeze is a strong, forceful expiration through the nose. It can be caused by an infection of the inside of the nose or from maggots of the nasal fly (see Unit 64).**

## **Difficulties in breathing**

**Infection of the lungs or windpipe will cause the animal to have**

**difficulty in breathing. It will make noises as it breathes.**

**A blockage of the windpipe caused by a foreign body or an abscess will also cause difficulties in breathing.**

**Fast (rapid) breathing**

**Fast breathing is caused by an infectious disease and is associated with a fever. It is easily noticed by looking at the movements of the chest as the animal breathes.**

**Treatment**

**If an animal coughs, and there is no discharge from the nose or a sign of fever, you should suspect a foreign body, dust in the windpipe or lungs or lungworms as causes of the problem. Check for any foreign body or if necessary treat for lungworms (see R11, R12 Annex 1).**

**A cough accompanied by a fever and discharge from the nose and eyes is caused by an infection. You should ask your veterinarian for help but if this is not possible you can give the**

**animal antibiotics or a sulpha drug (see R6, R7, R9, R10 Annex 1) for three or more days.**

**Sneezing when there is no fever is caused by a foreign body or nasal fly maggot in the nose. If an animal has a foreign body or abscess in the windpipe it will have difficulties in breathing but will not have a fever.**

## **Unit 72: Eye problems**

***Injury or infection of the eye or vitamin deficiencies can cause blindness in animals. Blind animals may not survive because they will be unable to find feed.***

***A problem in one eye is the result of injury or a foreign body. A problem in both eyes accompanied by fever, means that the animal has an infection or a serious disease. If blind in both eyes but without a fever, you should suspect a vitamin deficiency such as deficiency of vitamin A or B to be the cause.***

## **Learning objectives**



**After studying this unit you should know:**

- 1 The structure of the animal eye.**
- 2 Causes of eye problems.**
- 3 Treatment of eye problems.**

**The eye**

**The eye is important to the survival of the animal. The glass-like surface of the eye is called the cornea. The eye can be covered by the eyelids which protect it.**

**The eye**

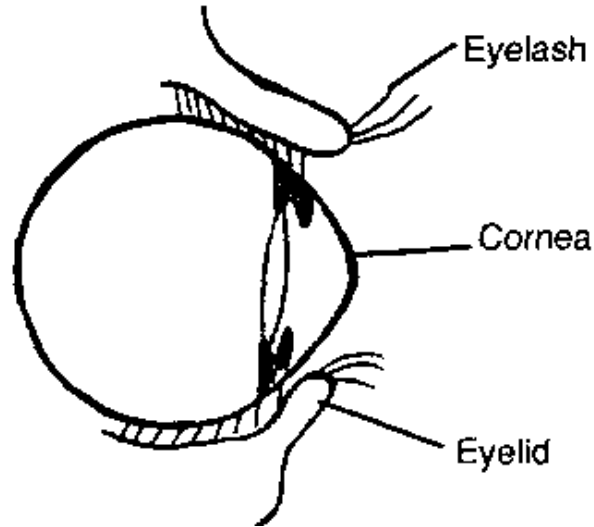

## Eye problems

If one eye is red, swollen and watery this may be due to:

- A foreign body such as sand, dust or a seed in the eye.
- An injury or cut to the cornea.
- Eye infection caused by flies or dirt.

If both eyes are swollen, red and watery and perhaps the animal

**is unable to open its eyes, this is a sign of infection. You should check the body temperature for fever. Many diseases cause eye problems.**

## **Blind animals**

**It can be easy to spot a blind animal as it will start to walk into objects. A blind animal will be difficult to keep.**

**To check for blindness make a threatening (quick) movement towards the animal's face with your hand without touching the animal or creating a wind which it might feel. If it does not blink, it is usually blind.**

**Vitamin A, which is present in green feed, silage and good hay is important for good eye sight. If animals are fed only old, dry feed or graze pasture in drought areas they develop night blindness and cannot see at dusk or night.**

## **Treatment**

**To treat eye problems you should:**

- **Ask someone to control the animal for you if it has a foreign body (dirt, sand) in the eye.**
- **With clean hands, and using the thumb and first finger, open the eyelids and press gently inwards.**
- **Use a clean, soft cloth to remove the foreign body from the eye.**
- **Put a drop of oil or ointment in the eye.**

## **Treatment**

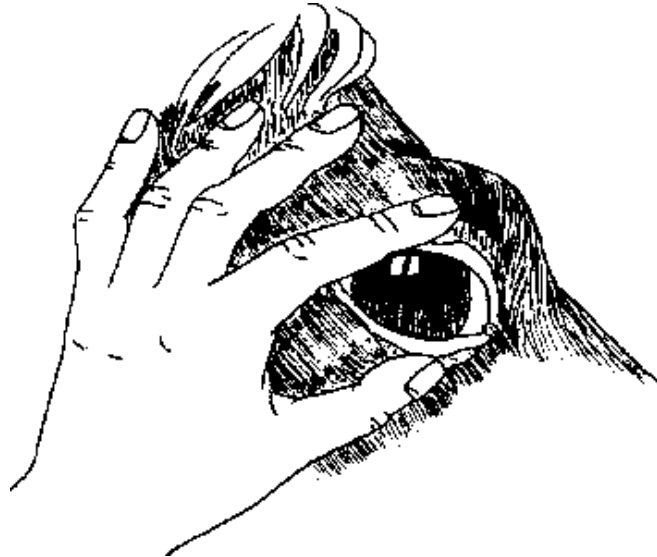

**If you have difficulty in removing a foreign object:**

- **Put a drop of olive, castor or cod liver oil in the eye as this can help to remove dirt.**
- **Put a little sugar in the eye, this will cause tears which will wash out the eye.**

**Use eye drops or ointment to treat red, swollen eyes (see R23**

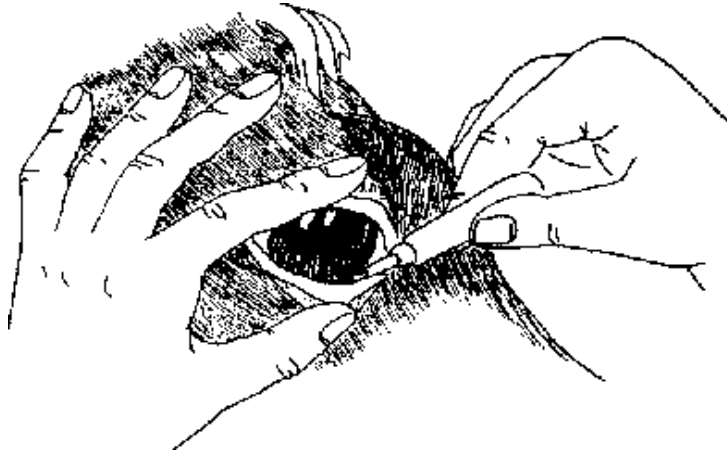
**Annex 1).****Treatment**

**If you cannot open a swollen eye do not force the eyelids open. You must get veterinary help. If both the eyes are swollen, red and watery and the animal has a fever put the animal in a shady place away from others. This is a sign of infectious disease and the animal may need to be treated with antibiotics.**

**Vitamin A and B1 deficiency are prevented by feeding silage or**

**supplemental feed during the dry season. These vitamins can also be injected (see R28 Annex 1) to treat these vitamin deficiencies.**

## **Unit 73: Wounds and bleeding**

***A wound is a cut or tear in the skin. All wounds bleed, they are painful and can become infected with germs or maggots.***

***Sometimes an animal can bleed from wounds inside its body which have been caused by parasites, by an accident, or in the female from problems as she gave birth. This is internal (inside) bleeding.***

***The blood carries oxygen from the lungs to every part of the body. If the body loses too much blood it will not get enough oxygen and the animal will die.***

***All wounds should be carefully cleaned and the bleeding stopped.***

## **Learning objectives**

**After studying this unit you should know:**

- 1 The causes of wounds.**
- 2 First aid for wounds.**
- 3 How to stop bleeding.**
- 4 Internal bleeding.**
- 5 Treatment of old wounds.**
- 6 The navel cord and wounds from castration.**

## **First aid for wounds**

**Animals can be injured by the horns and bites of other animals, thorns and sharp objects such as glass, wire and nails. These wounds will become infected with germs because of the conditions in which animals live.**

**If there is not too much bleeding, clean the wound with salt water and remove all dirt from it. Cut away the hair or wool from around the wound. If you have any disinfectant (R1 Annex 1) use it to dress the wound. Dusting powder can be used to keep the wound**



**clean (R5, R8 Annex 1).**

## **Bleeding**

**Bleeding from small or surface wounds can be stopped by pressing down hard on the wound with a clean cloth. If the blood soaks through the cloth put another on top rather than remove the first one. When the bleeding has stopped clean the wound and treat it.**

**You will need veterinary help to deal with bleeding from large or deep wounds. If you cannot stop the bleeding by pressing down with cloths you can use a tourniquet.**

**A tourniquet is a piece of rope or cloth which is tied across a blood vessel. It can only be used for wounds in the legs or tail.**

***You do not use a tourniquet around the neck.***

## **Bleeding**

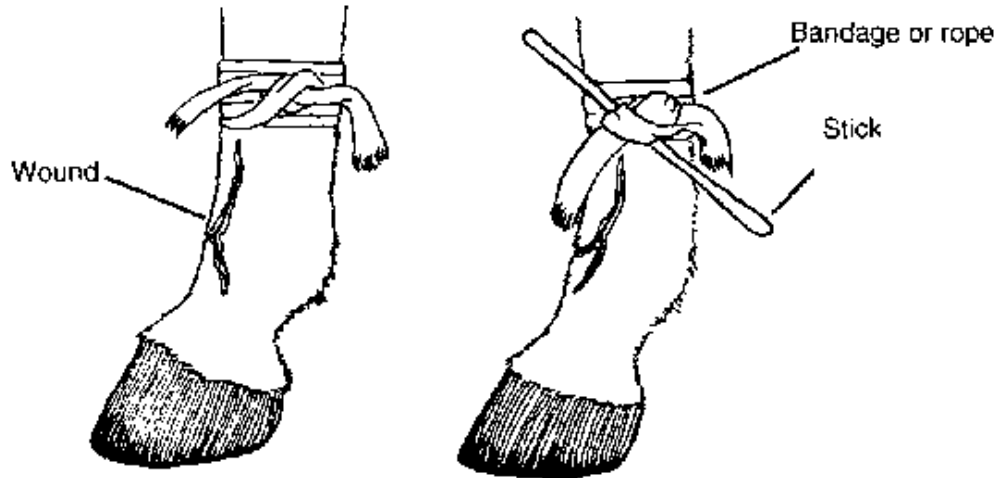

**Tie the rope around the limb above the wound. To tighten it put a stick under the rope and twist it tight until the bleeding stops. Do not leave the tourniquet on for more than 20 minutes. Release it slowly and if necessary tighten it again. Clean and treat the wound after the bleeding has stopped.**

### **Bleeding from a broken horn**

**If the horn of an animal is broken, try to stop the bleeding by**

**putting a pad or clean cloth on it and holding it in place with a bandage. A temporary tourniquet around the base of the horn will stop bleeding.**

**If this does not stop the bleeding, a red-hot piece of metal can be placed directly on the bleeding spot for half a minute to cauterize the horn and the blood vessel. This may have to be done to several bleeding spots on the horn or to the skin surrounding the horn.**

### **Bleeding from a broken horn**

Pad or clean cloth



Tourniquet at  
base of horn

**Remember do not leave a tourniquet on for a long time. If bleeding continues release the tourniquet every 20 minutes and then tighten it again.**

**Internal bleeding**

**This type of bleeding is dangerous. It can be:**

- **From the lungs and gut after an accident**
- **From the uterus or vagina after giving birth**

**The signs of internal bleeding are that the animal becomes weak and the rate of breathing increases. An animal with internal bleeding should be placed in a quiet, warm place and should be given water with a pinch of salt in it. Do not try to walk the animal as it may collapse and die.**

**You will need to ask for veterinary help if you believe that an animal has internal bleeding. In many cases there is nothing you can do to stop it. It is better to slaughter the animal.**

**In the horse and donkey internal bleeding from the vagina can occur after birth. If you cannot get veterinary help, pack the vagina with a clean cloth or towel which has been boiled and then cooled. Leave the towel in the vagina for a day or two then remove it.**

**Old wounds**

**If wounds are left without treatment maggots will infest the wound and cause more damage.**

**In some cases gangrene will develop in a wound. The wound worsens and turns black in colour with a very bad smell. Ask your veterinarian for help immediately.**

### **Wounds from operations**

**Wounds can be caused by operations carried out on the animal.**

**Wounds are caused by:**

- **Castration**
- **Docking (cutting the tail)**
- **Dehorning (removing the horn)**
- **Cutting the navel cord immediately after birth**
- **Cuts when the wool was sheared**

**All wounds should be cleaned with disinfectant (see R1 Annex 1). If you have a powder for wounds (R5, R8 Annex 1) you should use this daily until they heal.**

**Infected wounds or operations often swell from pus. The swelling is soft to the touch. These wounds, called abscesses, should have the pus removed by cutting through the skin with a sharp knife or scalpel to allow the pus to drain out. Abscesses are treated daily to keep the drain incision open, squeeze out the pus and flush out the wound with clean water or liquid disinfectant (see R1 Annex 1). An antibiotic or sulfa drug should be given by injection or orally for 3 -5 days (see R6, R7, R9, R10 Annex 1).**

#### **Unit 74: Fractures (broken bones)**

***If a bone is broken and there is no wound or bleeding it is called a closed fracture. When the bone is broken and there is bleeding this is called an open fracture.***

***Bone fractures in animals are difficult to treat especially in large animals.***

***It may be possible to successfully treat leg fractures in small, young animals.***

***You will need veterinary help to deal with all sorts of broken bones.***

## **Learning objectives**

**After studying this unit you should know:**

- 1 What can cause fractures.**
- 2 Signs of fractured bones.**
- 3 Treatment for fractures.**
- 4 Dislocation of bones.**

## **Cause of fractures**

**A fracture is a broken bone. Any one of the bones in the body can be broken but it is most common for the bones of the legs to be broken.**

**Fractures can result from the animal being kicked, falling, putting its leg in a hole or from fighting another animal.**

## **How to recognise when a bone is broken**



**A fracture will happen suddenly, it is not like a disease which takes time to develop. Sudden pain and an abnormal movement (lameness) often mean a fracture.**

**The animal will be unwilling to use the part of its body where the fracture is. You may hear the sound (crack) of the two ends of the broken bone as the animal moves. The area around the closed fracture will become swollen.**

**In an open fracture there will be a wound and bleeding. The ends of the broken bone may show through the wound.**

### **Dislocation of bones**

**This happens when the ends of two bones (joint) move apart from each other. You can feel that the joint is dislocated when you touch it.**

### **Dislocation of bones**

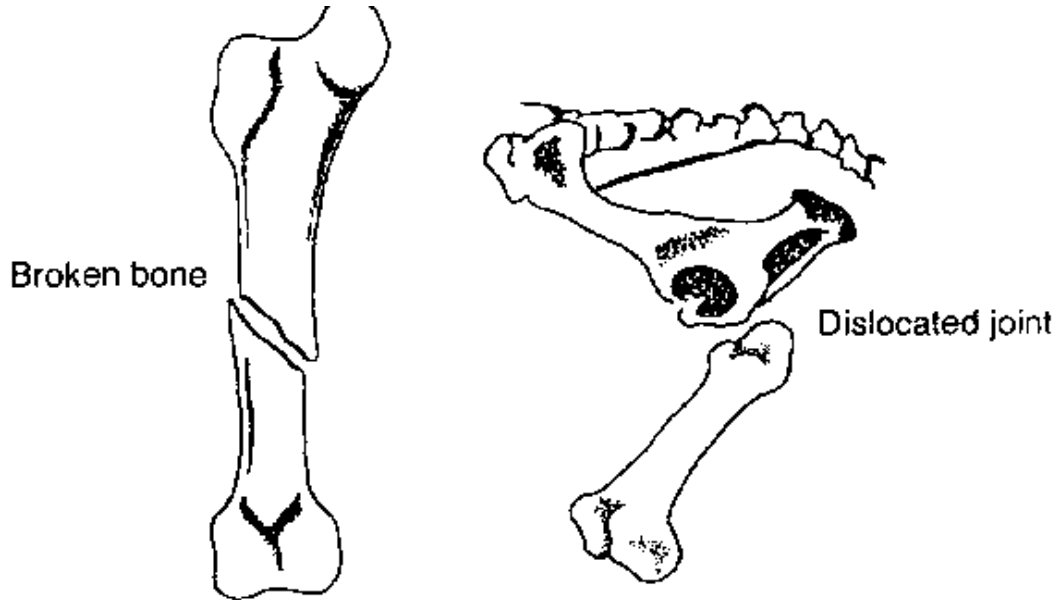

### **Treatment of fractures**

**In the case of a large animal you must prevent the animal moving and ask for help from your veterinarian. He may decide that the animal should be slaughtered.**

**Broken legs commonly occur in small or young animals. It may be**

**possible to treat. You should ask your veterinarian for help but if this is not possible ask the community health worker or the bone setter in the community to splint it. You can sometimes put dislocated bones back into place if you have someone to help you.**

## **Unit 75: Lumps under the skin**

*A lump under the skin can appear in any place on the body. Lumps may grow and increase in size or stop growing.*

*Some are hot and painful. Some lumps contain pus (yellowish matter) or blood.*

### **Learning objectives**

**After studying this unit you should know:**

- 1 What are abscesses.**
- 2 Abscesses of the lymph nodes.**
- 3 How to treat abscesses.**

## **4 Blood lumps under the skin.**

## **5 What are hard lumps under the skin.**

### **Abscesses (lumps of pus)**

**Abscess means infection under the skin. An abscess is a swollen, red and painful lump under the skin. It contains pus (yellowish matter).**

**An abscess is caused by germs. Germs get under the skin by:**

- **Bites from other animals or insects such as ticks and flies.**
- **Sharp objects such as thorns or nails piercing the skin.**
- **Injections or vaccinations which have been done with dirty needles.**
- **Diseases cause abscesses. The lymph nodes (glands) can develop abscesses in some diseases (see Unit 3).**

### **Abscesses in the lymph nodes (glands)**

**The lymph nodes in animals are similar to those which you have**

**in your body under the jaw and armpits. When an animal is infected the lymph nodes (glands) often become swollen and can be felt as lumps under the skin. In some diseases this swelling becomes an abscess.**

### **Abscesses in the lymph nodes (glands)**

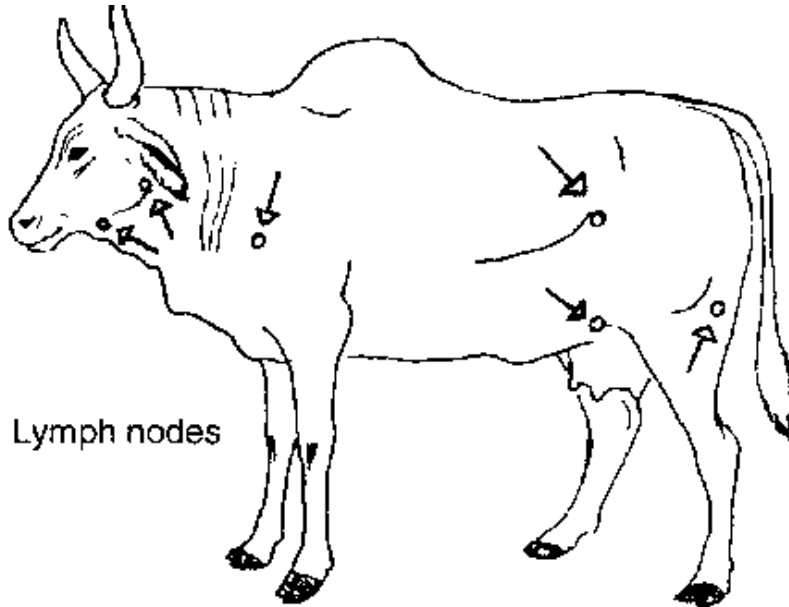

## **Treatment of abscesses**

**Some abscesses will break open and the pus will come out. You may need to open an abscess and can do so when it is soft. To do this quickly you should:**

- **Clean the abscess and the area around it with soap and water. Stick a clean needle into the abscess. If blood comes out put the needle into another point on the abscess. If pus comes out when the needle is put into the abscess, remove the needle and with a clean sharp knife, razor blade or scalpel make a small hole through the skin into the pus pocket. Then cut downwards through the skin into the pus and allow the pus to drain out of the abscess.**
- **When the pus has been removed, the abscess is treated as a wound (see Unit 73).**
- **If the abscess is not ready to open soak a cloth in hot water and put it over the abscess for 10 minutes at a**

**time. You will need to do this 4 times daily for a few days until the lump has become large and soft and can be opened.**

**Pus contains germs. You should clean up the pus and collect it in a piece of paper or cloth and burn it. Wash the area of skin around the abscess. Wash your hands and disinfect all needles and instruments used.**

**If the abscess is deep under the skin and does not break and the animal has a fever, you will need to ask your veterinarian for help. Antibiotics or sulpha drugs can be given by mouth or by injection for 3 days (see R6, R7, R9, R10 Annex 1) if you cannot get veterinary help.**

***Do not open abscesses of the lymph nodes but give an antibiotic or sulfa drug for 3 days to treat the infection.***

**Lumps of blood under the skin**

**This will result if an animal has been kicked or beaten. The lump is soft and not hot or painful and will disappear in 2 to 3 weeks.**

**You should not hit animals or try to lift an animal by holding its skin. This will cause blood lumps under the skin. If you want to sell animals for slaughter this will show as red-blue areas in the meat.**

### **Solid lumps**

**These are hard lumps which are not hot like abscesses or soft like blood lumps. Solid lumps may increase in size continuously or stop growing after some time. You will need to ask your veterinarian for advice on an animal which develops this type of lump.**

### **Strangles in horses**

**This is an abscess of the lymph glands under the jaw in young horses, mules and donkeys. The animal has a high temperature, there is an abscess under the jaw and a thick creamy discharge from the nostrils. You must isolate the animal and get veterinary help to open this abscess. When the abscess has been opened,**



**the animal can be treated with antibiotics.**

## **Strangles in horses**



### **Unit 76: Poisoning**

***Animals do not normally eat poisonous plants. A lack of other feed may cause animals to eat such plants. They may eat unfamiliar poisonous plants if they are moved to a new area where there are different poisonous plants.***

***Poisons such as warfarin (rat poison) and strychnine can be the causes of poisoning of animals. Arsenic dips may still be used in some areas and can lead to poisoning.***

***Sometimes animals are purposely poisoned by people.***

***Snake bite is the most common form of dangerous poisoning.***

## **Learning objectives**

**After studying this unit you should know:**

- 1 Signs of poisoning in animals.**
- 2 Causes of poisoning of animals.**
- 3 Treatment of poisoned animals.**
- 4 How to treat snake bites.**

## **Signs of poisoning in animals**

**A poisoned animal may die suddenly or will show the following signs:**

- **Excessive salivation.**
- **The mouth is open and the tongue hangs out.**
- **Diarrhoea and vomiting.**
- **Difficulty in breathing.**

## **Causes of poisoning in animals**

**There are many causes of poisoning in animals:**

- **There are very many poisonous plants. You should talk to your community and discover what poisonous plants are in your area.**
- **Seeds for planting may have been treated with chemicals. If animals or humans eat these they can die..**
- **Strychnine is a poison which can be used to kill wild dogs and wolves. It will also poison other animals**
- **Weed killers used in agriculture may be poisonous.**
- **Chemicals used to kill insects on plants or used for**

## **dipping against external parasites.**

- **Old paints, kerosene, diesel and other fuels and oils.**
- **Poison used to kill rats and mice.**
- **Animals can be poisoned by salt if they are not able to drink a lot of water.**

**Sometimes people deliberately poison animals.**

## **Treating poisoned animals**

**You can not do much in a case of poisoning. You should ask for veterinary help as soon as possible. Try to discover what caused the poisoning and stop other animals from being poisoned.**

- **Charcoal mixed with water and given as a drench is a good treatment for poisoning. Give 1 g m for every 20 kg of body weight.**
- **Kaolin (china clay), a white powder, can be mixed with**

**water and given as a drench. Give 10 gm to a small animal and 200 gm to a horse or camel.**

## **Snake bites**

**There are numerous snakes which are poisonous to animals and man. Animals are mainly bitten in the face and legs.**

**Usually we discover the animal was bitten by a snake when it is too late to do anything. If you are with an animal when it is bitten, you should examine the animal and move the hair or wool to find the two small, but deep, wounds made by the fangs of the snake.**

**You should use a tourniquet (see Unit 73) to stop the poison from a bite on the leg going through the body. Release the tourniquet every 20 minutes to allow the blood to flow. You should send for veterinary help immediately as it will be necessary to give the animal an injection against the snake poison.**

---





---

## Chapter 10: Animal health and the community

---

[Unit 77: Rabies \(mad dog disease\)](#)

[Unit 78: Tuberculosis \(TB\)](#)

[Unit 79: Hydatid disease](#)

[Unit 80: Screwworm](#)

[Unit 81: Ringworm](#)

[Unit 82: Disposal of dead animals](#)

[Unit 83: Disposal of dung](#)

[Unit 84: Health of the community](#)

---

### Unit 77: Rabies (mad dog disease)

***Rabies is a disease of dogs, foxes, wolves, hyaenas and in some places it is a disease of bats which feed on blood.***

***The disease is passed to other animals or to people if they are bitten by an animal with rabies. The germs which cause rabies live in the saliva of the sick (rabid) animal.***

***This is a killer disease but not every dog which bites is infected with rabies.***

## **Learning objectives**

**After studying this unit you should know:**

- 1 What is rabies.**
- 2 Signs of infection with rabies.**
- 3 What to do with rabid (sick) animals.**
- 4 What to do with animals and people who have been bitten by a rabid animal.**

## **Rabies**

**This is a disease of the brain which can affect all animals as well as humans. It is caused by germs which are transferred through the bites of rabid (sick) carnivorous animals such as dogs, foxes,**

## **wolves, hyenas and some bloodsucking bats.**

**When the rabid animal bites another animal or human, the germs which live in its saliva pass into the body through the wound caused by the bite. The germs travel along the nerves to the brain.**

**The time between the bite and the first appearance of signs that the bitten animal or human has been infected can take from 2 to 10 weeks or more. The time taken depends on the distance of the bite from the brain. If the bite is on the face or head, the bitten animal or human will quickly show signs, but if the bite is on the leg it will take much longer for signs to develop.**

### **General signs of rabies**

**You should first look for the marks of the bite and discover where and when the animal was bitten. All rabid animals show similar signs in the beginning.**

- **They change their normal behaviour and behave very**



**strangely.**

- **They stop eating or drinking.**
- **There is no change in the body temperature.**
- **Male animal will try to mate (mount) other animals.**

**These signs will continue for 3 to 5 days. Then, before it dies, the animal will develop one or the other of two types of the disease:**

- **The furious (mad) type of the disease makes the animal aggressive and it will bite anything.**
- **The quiet (dumb) type when the animal is quiet and does not move.**

**Rabies in the dog**

**Dogs show either of the two types of rabies.**

- **A dog with the furious or mad type of the disease will run around and bite anything. The eyes become red and saliva drips from the mouth.**

- **A dog with the dumb or quiet type of the disease cannot move. It looks as if it has a bone stuck in the mouth and saliva drips from the mouth.**

**Rabies in the dog lasts about 10 days before the animal dies. If the animal does not die after this length of time then it may not be suffering from rabies.**

### **Rabies in sheep, goats and cattle**

**Rabies is characterised by the animals becoming restless and excited. They may bite themselves and saliva drips from the mouth. The most important sign in cattle is that the animal bellows (calls) very frequently and with strange sound. The animals will become paralysed and die.**

### **Rabies in the horse and camel**

**The horse will show the furious (mad) type of the disease. It will kick and bite and show signs similar to colic (see Unit 40). The animal will die after paralysis of the back legs.**

**In the camel the signs of rabies are similar to those shown by an animal in the rut (see Unit 59).**

**What to do with a biting dog**

***Remember that not every dog which bites has rabies.***

**If the dog belongs to somebody ask the owner about its normal behaviour. If the dog is showing signs of rabies you must inform your veterinary officer immediately. The dog must be shot and if it has bitten anybody, they must be taken to a hospital immediately for vaccination.**

**What to do with a biting dog**



## Control of rabies

**Dogs in your community can be vaccinated against rabies. You should ask your veterinary service about vaccination against rabies.**

**If there is an outbreak of rabies, the livestock in your community can be vaccinated too.**

## **Unit 78: Tuberculosis (TB)**

***Tuberculosis (TB) is a chronic infectious disease of humans, livestock and wildlife. It is an important disease in cattle, buffaloes, pigs and camels.***

***Tuberculosis is present in many countries throughout the world.***

***The germs causing the disease form tubercles or nodules which are found in many organs and especially in the lungs. As the nodules increase in size the organs cannot function and the animal will die.***

***In humans TB usually affects the lungs and causes the patient to cough and spit. In bad cases the patient can spit blood. The***

***disease can kill people.***

## **Learning objectives**

**After studying this unit you should know:**

- 1 What is tuberculosis.**
- 2 How tuberculosis is spread.**
- 3 Relationship between tuberculosis of humans and animals.**
- 4 Controlling tuberculosis.**
- 5 The tuberculin test.**

## **Tuberculosis**

**Tuberculosis (TB) is a chronic infectious disease (see Unit 6) of the respiratory system. The germs which cause the disease form nodules (tubercles) in the organs of the body. It affects the lymph nodes, intestines, udder, skin and especially the lungs.**

**Human tuberculosis can infect cattle as well as humans. Cattle**

**tuberculosis can infect humans, cattle, buffalo, pigs and camels.**

### **Methods of infection**

**Cattle kept housed are more likely to develop TB than those which live out in the open. The yellowish-white sputum from the lungs which is coughed up by the sick animal contains TB germs. This spreads the infection to other animals.**

**Milk from infected cows can contain TB germs and spreads the disease to calves and humans.**

### **Signs of the disease**

**Tuberculosis of the lungs causes a harsh, dry cough. After a period of time the animal begins to cough up yellowish-white sputum (coughed up mucous).**

**The milk from infected animals will be normal in colour at first. After some time the udder can appear swollen even after milking. The fresh milk will soon look bad with a yellowish liquid forming in it. In bad cases only yellowish liquid will come from the udder.**

## **Control of tuberculosis**

**You will need help from your veterinarian to recognise, to treat and to control tuberculosis.**

**The tuberculin test is used to check if an animal is infected with TB. The test involves injecting a small amount of solution into the skin of the animals. Only those animals which have TB will show a reaction to the injection. You should ask your veterinarian about the tuberculin test.**

**It is advisable to boil milk from animals before drinking it. If you slaughter an animal which you suspect may have TB, ask your veterinarian to inspect the meat to see if it is fit to eat. This is because meat from an animal with TB can carry the infection to people who eat it.**

***Good hygiene, good feeding and good ventilation of any animal houses will prevent the disease from occurring.***

## **Unit 79: Hydatid disease**



***You may know someone in your community who has been in hospital to have a cyst (water filled bag) removed from their body. This is hydatid disease.***

***When sheep, goats, cattle, buffalo and camels are killed for meat, cysts, (water filled bags), may be found in the liver, lungs, heart and kidneys. These are the young of a small tapeworm which lives in the gut of the dog.***

***The cysts are called hydatid cysts and they cause damage to the organs in which they are found. They make the meat unfit to eat.***

***If a dog, fox or wolf eats the infected organs the tapeworms grow in its gut and produces eggs which can infect more ruminants or even humans.***

## **Learning objectives**

**After studying this unit you should know:**

**1 What is hydatid disease.**

**2 What are the problems caused by hydatid disease.**

**3 How to prevent and control hydatid disease.**

## **Hydatid disease**

**Dogs can be infected with very many small tapeworms (less than 1 centimetre long) which live in the gut. These produce eggs which are passed in the faeces and can remain alive in the earth and on grass for over a year. Cattle, buffalo, sheep, goats and camels can become infected when they graze on contaminated areas.**

**Inside the animal the eggs develop into large cysts (fluid filled bags) in the lungs, liver, brain, heart or kidneys. When animals are killed for meat the organs must be examined for these cysts.**

## **Problems caused by hydatid disease**

**The hydatid cysts damage the organs in which they develop. They weaken the animal but do not normally cause death. They make the meat unfit to eat and can cause loss of a valuable part of the animal which has been killed for food. Animals cannot be**

**treated to kill the cysts.**

**Hydatid cysts can develop in the same way in humans. Cysts in the lungs can be present for a long time before causing health problems while cysts in the liver, brain and kidney will kill.**

**Treatment involves the removal of the cysts by careful surgery and can mean the loss of a lung or kidney.**

**Preventing and controlling hydatid disease**

**Organs in which the cysts occur should not be eaten and should not be thrown away or fed to dogs. All meat and organs which contain cysts should be buried in a deep hole, or burned, to stop dogs or wild animals from eating it.**

**Animals cannot be treated to kill the cysts but the adult tapeworm in the dog can be killed. All dogs kept in the community should be regularly treated for worms every 3 months, and should not be fed raw meat or allowed to eat waste from animals killed for meat.**

**If you have to handle dogs, always wash your hands thoroughly**

**after handling. Children especially should be taught to wash their hands after playing either with dogs or in the streets. Vegetables must also be thoroughly washed and cleaned before they are eaten.**

***Your veterinary officer will advise on hydatid disease in your area. He can advise you on treatment of dogs kept in the community and how to deal with any stray or wild dogs.***

## **Unit 80: Screwworm**

***This disease is confined to the Americas. It is caused by the maggots of a fly which lays its eggs on wounds in humans and animals.***

***In these days moving livestock is easier and more common than it used to be. The spread of screwworm to other countries is possible. We should know more about the screwworm because if it spreads it can cause a lot of harm to livestock and people.***

***Cleaning wounds and daily inspection of livestock will stop***

***infection with screwworm and other maggots.*****Learning objectives**

**After studying this unit you should know:**

- 1 The screwworm fly and its maggot.**
- 2 Damage caused by screwworm.**
- 3 When to suspect infection with screwworm.**
- 4 How to treat and control screwworm.**

**The screwworm fly and maggot**

**The screwworm fly is nearly 1 centimetre long and is a shiny green in colour with a yellow or orange head and red eyes. The fly can lay from 10 to 400 eggs on a wound. The maggots hatch from the eggs within a day.**

**The screwworm fly and maggot**

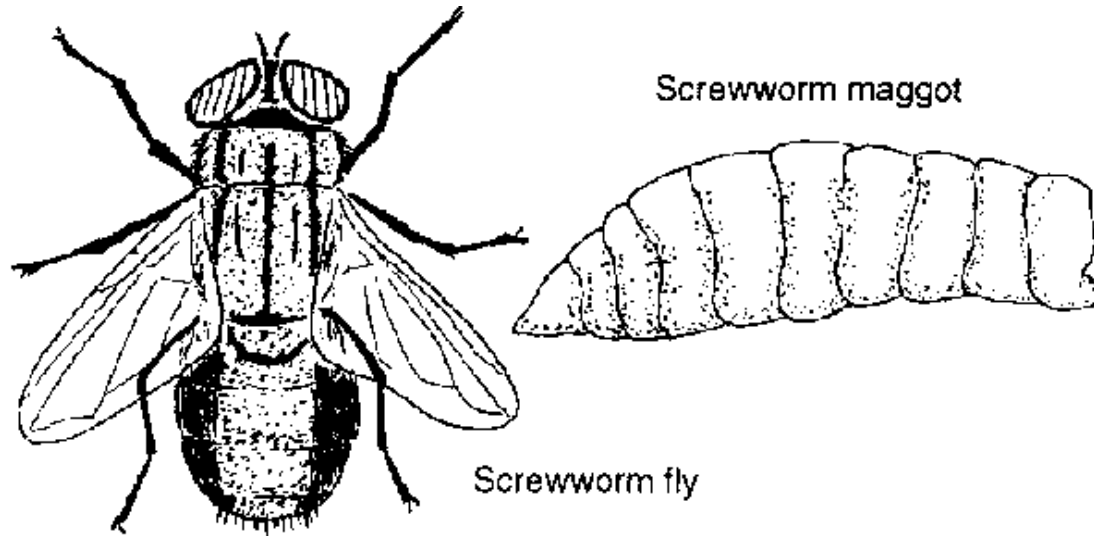

### **Damage caused by the maggots**

**The screwworm maggots will change a small wound into a large one by burrowing deep into the flesh. The maggots feed on the flesh (meat) of the animal for 3 to 4 days before falling off onto the ground. The maggot, which is more than 1 centimetre long, will change to a fly after one week.**

**The difference between the screwworm maggots and those of other flies is that the screwworm makes a very deep hole while maggots of other flies live on the surface of wounds. Infection with screwworm can lead to the death of the animal.**

**When to suspect infection with screwworm**

**If you find an unusually severe infection with maggots developing in a short time you must take some of the maggots to your veterinarian so that he can send them to a laboratory for checking.**

**You must do this immediately. Screwworm infections spread quickly. The infected animals must be examined and treated to stop the disease spreading.**

**Treatment and control**

**In South America the navel cord of new born animals must be dressed with a screwworm treatment. Castration, dehorning, tail docking, branding and shearing should not be done during the fly's breeding season.**

**Ask your veterinarian for information about screwworm and inform your community about it. It is important that the people in your community are aware of this disease.**

## **Unit 81: Ringworm**

***Ringworm is a disease of the hair and skin of most domestic animals throughout the world. It is not a worm but is caused by fungi on the skin.***

***Round areas (rings) of skin develop a greyish white crust and the hair is lost from the infected area. The infection usually does not cause the animal to itch.***

***Ringworm also infects humans.***

### **Learning objectives**

**After studying this unit you should know:**

#### **1 What is ringworm.**



**2 How to treat ringworm infection of animals.**

**3 Controlling infection of animals.**

**4 Ringworm infection of humans.**

## **Ringworm**

**Ringworm is caused by a fungus which infects the hair and skin of most domestic animals throughout the world. It causes the skin to become greyish white in colour and very rough. The hair falls out in the infected area. The areas of infection are round (rings) and usually occur on the head and neck. Cattle, especially calves, often suffer from the disease during the cold weather.**

**The infected areas rarely irritate the animal. The patches of infected skin will become bigger and several areas can join together.**

## **Treatment**

**Gently brush off the dry, crusty skin and loose hair from the infected area with soap and water. Tincture of iodine solution should be applied to the area every other day or a mixture of**

**tincture of iodine and glycerine in equal parts can be applied every day (see R 25 Annex 1). Ringworm can be successfully treated but it may take over one month.**

**Commercial preparations containing an antibiotic called griseofulvin are available for treating ringworm (see R 25 Annex 1). The antibiotic can be applied to the skin or given mixed in the feed. Your veterinary officer will advise you on what treatment is available locally.**

### **Controlling ringworm infection in animals**

**The disease can be easily spread from from one animal to another through contamination of brushes, ropes and feed or water troughs. It occurs particularly where animals are kept in crowded damp conditions.**

**Animals should be examined frequently for signs of ringworm. Any animals which develop the disease should be separated and quickly treated. Avoid keeping animals in crowded conditions, give good feed and if possible vitamin supplements.**

## **Ringworm infection of humans**

**The fungi which infect animals can also infect humans. If you handle infected animals you should keep your fingernails very short and scrub your hands with hot water and soap after handling animals. The infection will form light red areas of skin. Children can often be infected with ringworm and infection on the head will cause loss of the hair. If you or anyone in your community develops ringworm, you should go to your nearest clinic for treatment.**

### **Unit 82: Disposal of dead animals**

***If an animal dies, other than as a result of being slaughtered for meat, you must dispose of the body (carcass).***

***The carcass must be properly disposed of to prevent disease from spreading.***

***Carcasses can be buried in a deep hole or burnt.***

## **Learning objectives**

**After studying this unit you should know:**

- 1 The handling of dead animals.**
- 2 Anthrax and sudden death.**
- 3 Post mortem (opening the body of the dead animal to check it).**
- 4 How to bury animals.**
- 5 Burning dead animals.**

## **Handling dead animals**

**If you do not know why an animal has died you should always think of the diseases which humans can catch from animals like rabies, anthrax and others. Always take care and carefully wash and disinfect your hands and clothes afterwards.**

**If you can you should inform your veterinarian about the dead animal as he may want to do a post mortem (after death) examination. When a veterinarian carries out a post mortem examination he will cut open the body to find out what caused it**

**to die. This will help him to treat other animals and stop disease spreading.**

## **Stiffening of the body after death**

**One to seven hours after it has died an animal's body will become stiff and hard because of chemical changes in it. This happens quickly in hot weather taking longer in cold temperatures.**

## **Anthrax**

**Anthrax is a very dangerous infectious disease of livestock. You should suspect anthrax if:**

- **An animal suddenly dies having shown no signs of being sick.**
- **The animal has had a very high temperature (fever) and bloody diarrhoea, dying 1 to 3 days after becoming sick.**
- **Dark blood comes out of the nose and anus after death and shows no sign of clotting.**

**Anthrax can kill people so you must be very careful when you handle the dead animal. You should burn or bury the dead animal immediately. All infected material such as bedding, soil and feed must also be burnt.**

**The anthrax germs can stay infective in the soil for many years.**

***You must ask your veterinarian for help and advice immediately in the case of anthrax.***

## **Burying**

**Burying dead animals is better than burning them. Always chose a site away from any river, well or spring. Dig a pit (deep hole) 2 metres deep and wide enough to take the number and size of the dead animals. Put the carcasses into the pit so that they are on their backs with the feet upwards. In the case of animals dying from anthrax you must fence off the area after burying the animals. The anthrax germs can survive in the soil for many years and you must make sure that other animals and people do not go onto the site.**

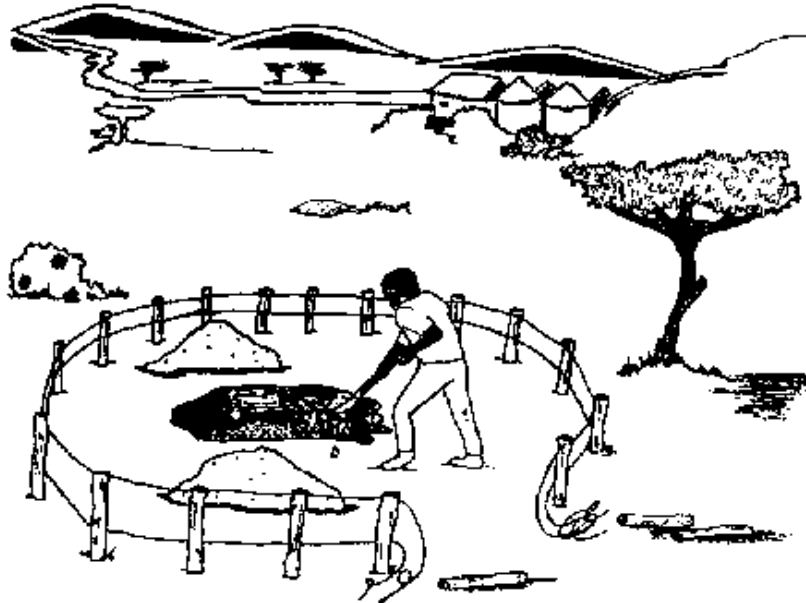

## **Burning carcasses**

**In order to properly burn dead animals you must put fire under and over the carcass. The fire must be very hot and big enough to burn all of the body.**

**To do this first dig a channel in which to put the body. A channel 1 metre long, 30 centimetres wide and 40 centimetres deep will be needed for a cow or horse. Put straw and wood inside the channel and place the carcass on top. Cover the animal with straw and wood before spraying the pile with some kerosene or petrol and lighting it.**

### Burning carcasses

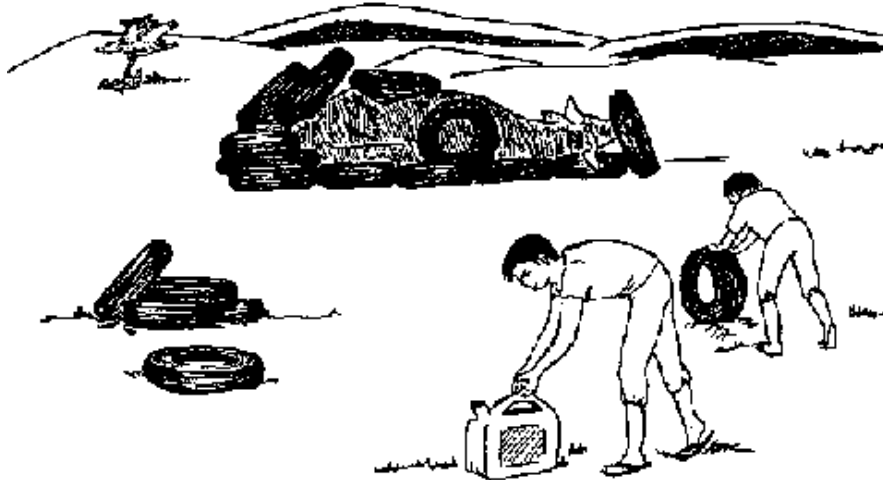



**You can use old tyres to burn carcasses. Place the dead animal on a layer of tyres and cover the body with more tyres. Use kerosene or petrol to start the fire.**

***Remember that proper disposal of carcasses is essential to prevent disease spreading to other animals and people.***

***You now know about infectious diseases such as rinderpest, foot and mouth, tuberculosis and anthrax but you should also ask your veterinarian about other infectious diseases in your area.***

***To be a successful PAHCW you must always ask questions and observe things. This is the way to learn.***

## **Unit 83: Disposal of dung**

***The droppings or dung of domestic animals must be disposed (got rid of). Infections, e.g. parasites, can spread through dung. It will also be used by various flies as a place to lay their eggs.***

***Animal dung can be used to fertilise soil for crops, can be dried and used for fires or may be mixed with clay to make building materials.***

## **Learning objectives**

**After studying this unit you should know:**

- 1 How we can use animal dung.**
- 2 Why we need to dispose of dung.**
- 3 How to safely dispose of dung.**

**What dung can be used for**

**Animal dung is used for a variety of different things throughout the world:**

- Cattle dung is mixed with clay or mud to make bricks or the walls of houses.**
- It is dried for fuel for fires.**
- It is used as a fertiliser on soil used for growing crops.**

**Animal dung is an excellent fertiliser for soil and can be used to improve the quality of any soil which is used to produce crops.**

### **Why we need to dispose of dung**

**Germs which cause disease and the eggs of parasites which infect the animals are present in the dung. Removing dung from where the animals are kept helps to reduce the spread of disease. If animals are kept in stables or other enclosed areas the dung must be removed regularly as it will become the breeding place for germs.**

**Dung will also be used by flies which will lay their eggs in it and the maggots will feed on the dung. The flies carry germs from the dung and can spread disease. Some of the flies which breed in dung bite animals and suck their blood. These flies can also spread disease, e.g. surra in camels (see Unit 62).**

### **Disposing of dung**

**Collect the dung into heaps to slowly rot. As it rots the dung produces heat which will kill germs and the eggs of parasites.**

**The heap should be mixed and repiled regularly in order that all the material it contains becomes hot.**

**When it is well rotted the dung can be used to fertilise agricultural land.**

**Do not make dung heaps close to houses or too close to stables or other animal housing. Flies attracted to it will become a nuisance. The smell can also be unpleasant. Do not place dung heaps on land which is near to water or may be flooded when the rainy season comes. Dung can contaminate the water and spread disease to animals which drink it. If a lot of animal dung or waste enters a stream or river it can cause the death of fish.**

## **Unit 84: Health of the community**

***In order to be healthy we need foods such as milk, eggs and meat which we get from animals. The animals we keep must be healthy so that the food we get from them is good for us.***

***When animals are kept in contact with the community, we***

***should control where they are allowed to go, what they drink and what they eat.***

## **Learning objectives**

**After studying this unit you should know:**

- 1 How to keep animals in the community.**
- 2 Animals and the community's water supply.**
- 3 Handling meat, eggs and milk for the community.**

## **Animals in the community**

**Traditionally animals may be left to wander around the roads or between the houses in a community. They are allowed to eat whatever they can find and to drink dirty, stagnant water. This is not a good way to keep animals which can easily become sick or stolen when kept like this.**

**At the same time it is not good for the community as the animals can spread disease to people or spoil the community's water supply. You should talk to the people in your community and**

**advise them of the problems which can come from keeping animals in this way. Advise them on how to house animals and take care of them.**

## **The community's water supply and animals**

**Your community may get its water supply from a pond, river, spring, tank, well or borehole. You should help to keep this water clean and safe to use.**

- **Do not allow people to throw dead animals into the water..**
- **Do not bury animals near the water or allow dung in or near it**
- **River or stream water for use by the people should be drawn up stream from the village. Boil, filter or disinfect it before use. Let animals drink water further downstream.**
- **If your water comes from a pond or borehole have**

**special troughs built for the animals to drink from. Do not let animals drink directly from the pond. Animal droppings and urine will get into the water which is bad for the health of people and will spread disease amongst animals.**

**The community's water supply and animals**

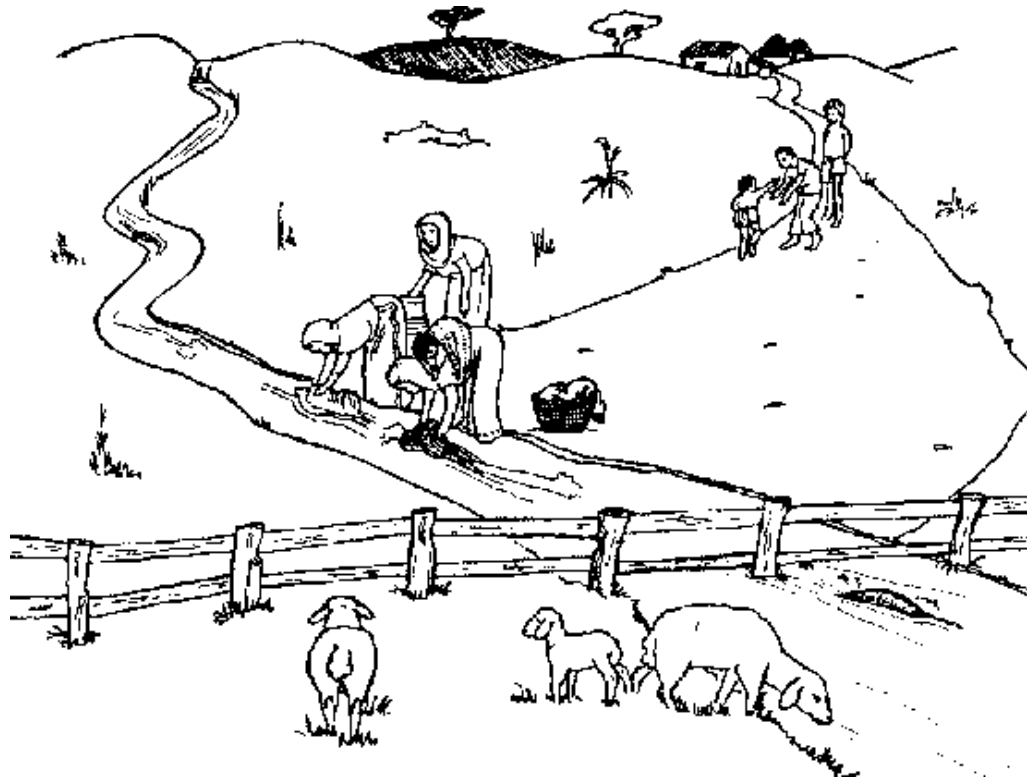

## **Slaughtering animals**

**Animals to be slaughtered for meat should be healthy. They**



**should be hung during slaughtering and fully bled. The slaughterhouse (abattoir), or the place of slaughtering, should be fenced off and kept clean. Unusable animal organs and waste should be buried in a deep hole. They should not be thrown into a river or given to dogs.**

### **Meat for the community**

**Meat should be sold separately from other foods. It must be protected from heat, flies and other animals. Hands should be washed before and after handling raw meat. Any surfaces on which meat has been placed and any knives should also be thoroughly cleaned.**

**Meat must be sold fresh each day or dried, salted or cooked. Dried or salted meat will keep for a long time. Cooked meat should be eaten at once or within a very short time of cooking.**

**Eating raw or uncooked meat can be very dangerous. Eating infected meat can cause vomiting, diarrhoea, fever and sometimes death.**

## Eggs and milk

**Milk is the one animal product which everyone uses in their food. It can be the source of several diseases (see Unit 22).**

**Eggs provide a good body-building food. Chicken eggs may be eaten raw when fresh. Duck eggs should always be cooked before they are eaten.**



## Annexes

---

[Annex 1: Medicines](#)

[Annex 2: Important veterinary tools \(instruments\)](#)

[Annex 3: Important techniques](#)

[Annex 4: Selection of animals for breeding](#)

[Annex 5: Record keeping](#)

[Annex 6: Weights and measures](#)

[Annex 7: Explanation of terms and index](#)

---

## **Annex 1: Medicines**

### **Terms and words used in medicine**

**Medicines (drugs) when given properly will cure animals. When you use medicines you will need to know the following words:**

- **Intramuscular (i.m.) injection, intravenous (i.v.) injection and subcutaneous injection (see Injections Annex 3).**
- **Drenching, boluses, dipping and spraying (see Annex 3).**
- **Powder, a dry medicine which is mixed with water to give to the animal or a dry medicine which is used on the**

**outside of the animal.**

- **Ointment, creamy or oily medicine to spread on the skin or on different parts of the body.**
- **Drops, liquid used in small amounts, such as eye or ear drops.**
- **Dress, to clean a wound and put on disinfectant.**
- **Sulpha and antibiotics, medicines which are used to kill germs.**
- **Litre (L), millilitre (ml), kilogram (Kg), gram (gm), milligram (1 gm = 1,000 mgs) (see Annex 7).**
- **International units (I.U.) are units used to measure antibiotics.**

**Name of medicine (drugs), how to use it, how much to give and other information**

.....

---

## **Size and weight of animals**

**It is very important to know how much medicine you need to give to each animal. This book deals with 14 different types of animals which can be divided into groups according to their size.**

**Large animals:** Camel, horse, large cattle and buffalo.

**Medium animals:** Small cattle, donkeys, mules, llamas and large pigs.

**Small animals:** Sheep, goats, alpacas, small pigs, young cattle, young buffalo and young camels.

**Very small animals:** Young sheep, goats and piglets.

**Birds:** Chickens, ducks and turkeys.

## **R1 Disinfectant for wounds**

**These are usually liquids and are used to clean dirt from the**

## wound and kill germs.

- **Salt water:** Add a large spoonful of salt to a litre of clean water to make a very cheap and good disinfectant for wounds.
- **Acridine:** An orange or red powder. Prepare by adding one part of powder to 1 000 parts of clean water.- This is very good for cleaning wounds and abscesses after removing the pus.
- **Tincture of iodine:** A dark brown liquid used to dress wounds.
- **Gentian violet:** A liquid for dressing wounds and burns.
- **Alcohol:** Clear like water, this is good for cleaning wounds and also the hands before carrying out operations e.g. castrating animals.
- **Dettol and TCP (solution of phenol and sodium**

**salicylate): Trade names for disinfectants which can be used on the animal, for your hands and instruments.**

.....  
.....

## **R2 Disinfectants for animal houses and equipment**

- **Hot water and soap. Carbolic soap is the best if you can find it.**
- **Jeyes, Chlorox and creosote can be used by adding 5 parts to 100 parts of water.**

.....  
.....

## **R3 Dressings for mouth lesions (mouth wash)**

**Use a big syringe to flush out the mouth (see Annex 2).**

- **Salt and water or potassium permanganate or hydrogen peroxide.**

- **Copper sulphate (blue stone). Use 2 parts in 100 parts of water.**
- .....
- .....

## **R4 Dressings for the foot**

**These solutions are used to kill germs causing foot rot or infecting wounds of the foot.**

- **Tincture of iodine or Dettol or TCP (solution of phenol and sodium salicylate).**
- **Copper sulphate (blue stone) use it as a 10% solution by adding 10 parts to 90 parts of water.**
- **Formaldehyde: This is available as a 40% solution in bottles. Add one part of this to 8 parts of water to make a solution of the correct strength.**
- **Chloramphenicol: A spray. This is good for use on the**



**foot and on other wounds.**



**R5 Antibiotic powders for wounds**

**These must only be used to kill germs in wounds.**

- **Chloramphenicol, tetracycline or any antibiotic as a powder can be dusted over the wound.**



**R6 Antibiotics for injections**

**These are injected into the animal either subcutaneously, intramuscular or intravenously.**

- **Procaine penicillin G: Give 100,000 I.U. for every 10 kg of body weight by intramuscular injection for 3 to 4 days.**

- **Benzathine penicillin G: Give 120,000 I.U. for every 10 kg of body weight by a single intramuscular injection.**
  - **Oxytetracycline: Give 50 mg for every 10 kg of body weight by intramuscular injection for 3 to 4 days.**
- .....
- .....

### **R7 Antibiotics by mouth (oral)**

**These may be as powders, boluses, capsule, tablets or pastes.**

- **Oxytetracycline tablets: Give one 250 mg tablet for every 20 kg of body weight every day for 4 to 5 days.**
- .....
- .....

### **R8 Sulpha drugs for wounds**

**These powders are very good for keeping the wound clean and**

**dry.**

- **Sulphanilamide or sulphathiazol: These are very good dusting powders for wounds.**
- **Negasunt powder: This is a mixture of mainly sulphanilamide and can be used daily on a wound.**

.....  
.....

### **R9 Sulpha drugs by mouth (oral)**

- **Sulphaguanidine: This may be given orally as a bolus or can be broken and mixed with the animal's feed. Give 50 mg for every 10 kg of body weight every day for 3 to 4 days.**

.....  
.....

### **R10 Sulpha drugs by injection**

- **Sulphadimidine solution: Give 1 gm for every 10 kg of body weight by intravenous or subcutaneous injection every day for 3 to 4 days.**
- .....
- .....

## **R11 Internal parasites of ruminants**

**These may be available as drenches, pastes, boluses or for subcutaneous injection.**

- **Albendazole: Given as a drench or paste is very good against roundworms, tapeworms and flukes.**
  - **Levamisole: Given as a drench or subcutaneous injection kills roundworms and lungworms.**
  - **Nitroxynil: Given by subcutaneous injection is very good against both young and adult flukes.**
- .....
- .....

## **R12 Internal parasites of horses, donkeys and mules**

**These may be available as drenches, pastes or powders to mix in the feed.**

- **Fenbendazole and febantel: Both are very good against young and adult gut worms and lungworms.**
  - **Haloxon: Mixed in a feed this is active against gut worms, lungworms and bots.**
- .....
- .....

## **R13 Internal parasites of pigs**

**These are available as drenches, for injection or to mix in the feed.**

- **Levamisole: Very good activity and can be given subcutaneously.**
- **Piperazine salts: Usually mixed in a feed, active against**

**gut worms.**

- **Parbendazole and fenbendazole: As a drench or in feed.**



### **R14 Internal parasites of poultry**

**Birds can treated by giving medicine orally or adding it to feed or water.**

- **Piperazine salts: can be given as a dose by mouth or may be added to feed or drinking water.**
- **Tetramisole or levamisole: given in the drinking water.**



### **R15 Treating lice, fleas and mites**

**Treatments are available as dusting powders, pour on, dips and**

## **sprays.**

- **Coumaphos: Used for ruminants as sprays, dips and powder and as powder for pigs, poultry and horses. Active against fly maggots.**
- **Amitraz: As a pour on or spray for pigs against mange and lice.**
- **Lindane: As an oil used for mange in equines.**
- **Malathion: Used as powder for poultry.**

.....  
.....

## **R16 Treatment for ticks**

- **Coumaphos, diazinon and flumethrin: Available as dips and sprays.**

.....

.....

## **R17 Treatment for trypanosomes**

- **Suramin: Very good in camels, also used for equines.**
  - **Samorin: Used in ruminants and equines.**
- .....
- .....

## **R18 Coccidiostats for chickens and ducks**

**Coccidiostats are mixed with feed or drinking water.**

- **Sulphaquinoxiline: Given twice a day for 2 days in water, repeated 3 days later.**
  - **Amprolium and zoalene: Given in the feed.**
- .....
- .....

## **R19 Mastitis**



**Antibiotics or sulpha drugs given by mouth or by injection are used to treat severe mastitis.**

- **Penicillin and streptomycin: Special mastitis tube, insert the end of the tube into the teat and empty the contents into the udder. Massage udder. Repeat treatment for 3 days after each milking.**
  - **Tetracycline for intramammary use.**
- .....
- .....

**R20 Bloat (tympany)**

**Many treatments given in Unit 8.**

- **Stop Bloat and Birp are commercially produced treatments for bloat.**
- .....
- .....

## **R21 Diarrhoea**

**Antibiotics or sulpha drugs are given by mouth when fever is associated with diarrhoea. Water containing salt and sugar is given by mouth (see Unit 68 and R27).**

- **Catechu: A brown powder which is mixed with water and given as a drench. Small animals give 2 gm, larger animals 15 gm.**
- **Chalk: Mix with water and give as drench. Large animals 120 gm, medium animal 80 gm, small 40 gm and very small animal 20 gm.**
- **Kaolin (China clay): A white powder mixed with water and given as a drench, give twice as much as for chalk.**

## **R22 Colic or constipation (animal cannot defecate)**

- **Liquid paraffin or linseed oil given by mouth. Large animal give 500 ml (0.5 L), medium animal 250 ml (0.25 L), small animal 100 ml and very small animal give 20 to 50**

**ml. There are many forms of paraffin. Make sure that you use medicinal liquid paraffin. Check with your veterinarian.**

- **Magnesium sulphate (Epsom salts): White powder which is dissolved in water and given by mouth. Dose for large animals is 500 gm, medium animals 250 gm, small animals 50 - 80 gm and very small animals 5 to 20 gm. Mix the powder with clean water and give as a drench. Do not give horses, donkeys and mules more than 100 gm.**

- **Castor oil: Give to horses, mules, donkeys and pigs.**



### **R23 Drops and ointments for eyes**

- **Tetracycline ointment: Put a little ointment in the corner of the eye, 4 or 5 times a day, for 3 to 5 days.**

- **Betamethazone and neomycin eye drops: Put drops in twice a day for 3 to 4 days.**



### **R24 Drops for ears**

**Warm water and soap can be used to gently clean the ear.**

- **Gammexane: Mixed in paraffin and used to treat ear mange.**



### **R25 Ringworm treatment**

- **Tincture of iodine: Remove crusts around lesions. Apply iodine solution every 2 days as required.**
- **Griseofulvin: This is a powder which is added to the**

**feed.****R26 Poisoning treatment**

- **Charcoal mixed with water. Give 1 gm of charcoal for every 20 kg body weight. Can repeat daily for 4 - 5 days.**
- **Kaolin (China clay) mixed with water. Give as a drench, 10 gm to a small animal, 200 gm to a horse, cow or camel. Can repeat daily for 4 to 5 days.**

**R27 Oral rehydration fluids**

**Can be made by adding 6 teaspoons of sugar and half a teaspoon of salt to 1 litre of clean, warm water. Give this as a drench or from nipple bottle.**

- **Sheep or goats give 500 ml 4 times a day for 3 days.**

- **Larger animals give 5% of body weight 2 times a day.**
- .....
- .....

## **R28 Vitamin deficiency in ruminants**

- **Vitamin A, D or E: Inject into the muscle according to body weight. May be repeated in 30 days.**
  - **Vitamin B1 or a mixture of B vitamins: Inject according to label directions into the vein, muscle or under the skin. Injections may be repeated daily.**
- .....
- .....

## **Annex 2: Important veterinary tools (instruments)**

**There are a number of veterinary tools (instruments) which the PAHCW will need in order to be able to carry out his work. These are:**

- **Thermometer with carrying case**

**The thermometer is an important tool (see Unit 4) and must be kept clean, carefully stored and carried so that it is not broken.**

- **Syringes and needles**

**Syringes are made of glass or plastic and are used to inject drugs (medicines) or vaccines into the body. There are two types of needle fitments and you must make sure that the needle fits the syringe correctly before you use it.**

**Different sizes of needles are needed for different injections. Thin needles are used to give intramuscular injections and shorter needles are used to give subcutaneous injections. Ask your veterinarian about the needles and syringes you will need to use in your work.**

## **Syringes and needles**

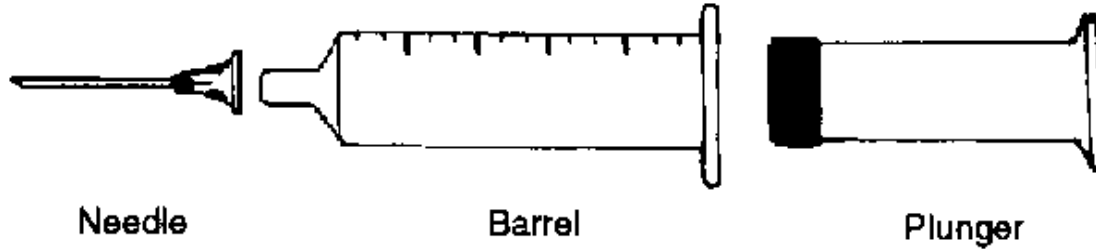

- **Dose syringe**

**Large syringes made of metal, plastic or glass can be used to wash out (flush) mouth lesions, wounds or abscesses. These are used with a nozzle and not a needle fitted to them.**

### **Dose syringe**



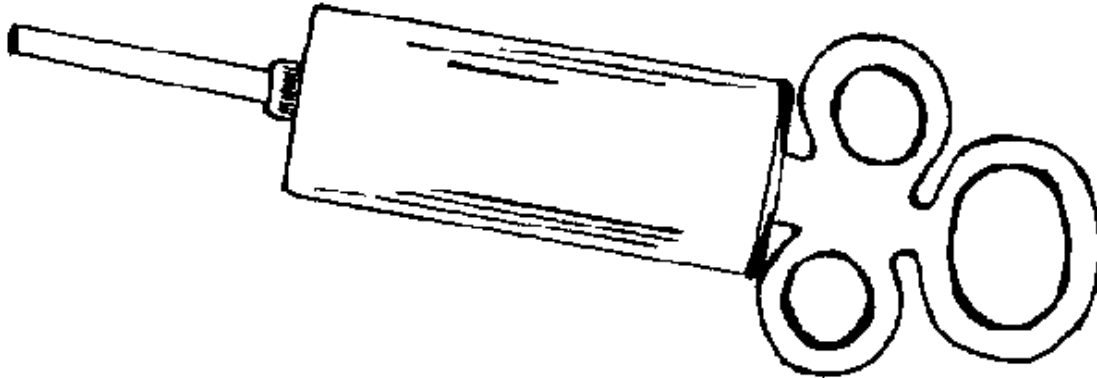

- **Drench bottle**

**Any long-necked bottle will do. If 20 cm of rubber hose is attached to the mouth of the bottle it will make it easier to put the medicine into the mouth (see 4, Annex 3).**

- **Stomach tube (See 6, Annex 3)**

- **Teat Catheter**

**This is used to remove milk from the udder of an animal with mastitis (see Unit 22).**

- **Castration instruments**

**These are, the Burdizzo, the emasculator and the elastrator with rubber rings (see Unit 14).**

- **Scalpels, blades or sharp knives**

**These are necessary to cut and open wounds and abscesses and to use for castration and other simple operations. A clean, sharp, shaving razor can also be used.**

- **Trocar and cannula**

**Used to get rid of gas from the rumen of an animal with bloat (see Unit 8).**

- **Nose holder and twitch**

**The nose holder is used to control cattle and buffalo (see Unit 10) and can be made by the blacksmith. The twitch is used to control horses, donkeys or mules (see Unit 37) and you can make it yourself.**

- **Ropes to restrain animals**

**Ropes will be needed to tie up, control and cast animals (See Annex 3, Number 13).**

- **Hoof cutters and clippers**

**Hoof cutters are needed for hoof trimming (see Unit 11) and clippers are used for nails and teeth.**

- **Bottles of disinfectant, tincture of iodine and alcohol**

**These and some cotton wool, bandages and pads, or clean cotton cloths are needed for wounds.**

- **A strong bag**

**A strong leather or canvas bag is needed to carry tools in, to protect them and to keep them clean and dry.**

### **Annex 3: Important techniques**

---

- [1. Sterilisation of instruments](#)
  - [2. Injections](#)
  - [3. Vaccinations](#)
  - [4. Drenching](#)
  - [5. Boluses \(tablets\)](#)
  - [6. Stomach tubing](#)
  - [7. Cleaning the udder](#)
  - [8. Taking blood samples](#)
  - [9. Making blood smears](#)
  - [10. Collecting samples for the laboratory](#)
  - [11. Collecting faecal samples](#)
  - [12. Spraying](#)
  - [13. Dipping](#)
  - [14. Knots and tethering](#)
- 

## 1. Sterilisation of instruments

**Sterilisation means killing germs. Syringes, needles, scalpel blades, teat catheters and scalpels must be thoroughly cleaned and sterilised before they are reused. Scrub away all blood and**

**fat from the instruments and thoroughly clean them. You can use a brush and soap and water to do this. Put the instruments in a clean cooking pan or a metal container, cover them with clean water and boil for 15 minutes. Syringes must be separated into plunger and barrel for sterilising.**

### **Sterilisation of instruments**



**Instruments which cannot be boiled should be thoroughly scrubbed clean and then placed in, or wiped with, alcohol or Dettol before being used again. *Remember only use boiling wafer to sterilise syringes used for vaccinations. If chemicals are used on the syringes they can destroy the vaccination before it gets to the animal.***

## 2. Injections

There are several ways to inject animals with drugs and vaccines.

- Intramuscular injections (i.m.)

### Intramuscular injections (i.m.)

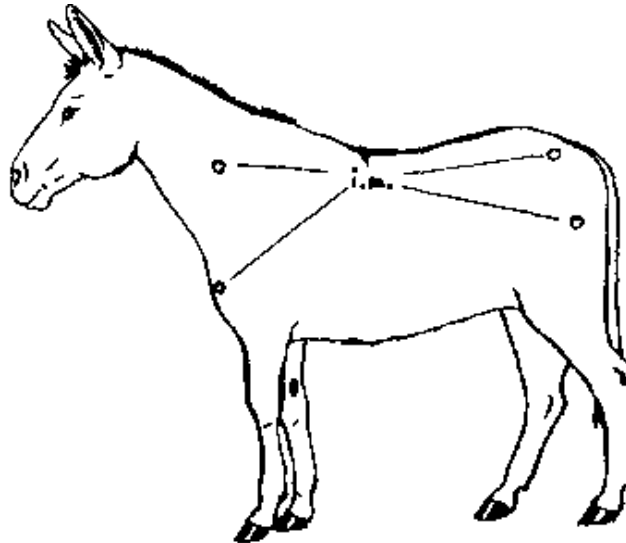

Inject into the muscle of the hip, the upper back leg, the middle of

**the neck, the shoulder or chest muscles. Point the needle straight into the muscle. Before injecting the drug, pull back the plunger a little to make sure that the needle did not enter a blood vessel. If blood enters the barrel of the syringe pull the syringe out and try another place. If no blood enters the barrel inject the drug into the animal.**

- **Intravenous injections (i.v.)**

**This injection is made into the big vein (jugular) in the neck. This vein collects blood from the head and carries it to the heart.**

**You will need someone to help you to control the animal and to find the vein. In order to make the vein show, block it at the base of the neck. Use your hand to do this in small animals and for large animals use a rope around the bottom of the neck. Blocking the vein will make the blood build up inside it and it will stand out like a cord or rope under the skin. Put the needle into the vein. Check that the needle is in the vein by pulling the plunger of the syringe, back a little when blood should show in the barrel. Remove your hand, or the rope, from the bottom of the neck and**



**slowly inject the drug.**

## **Intravenous injections (i.v.)**

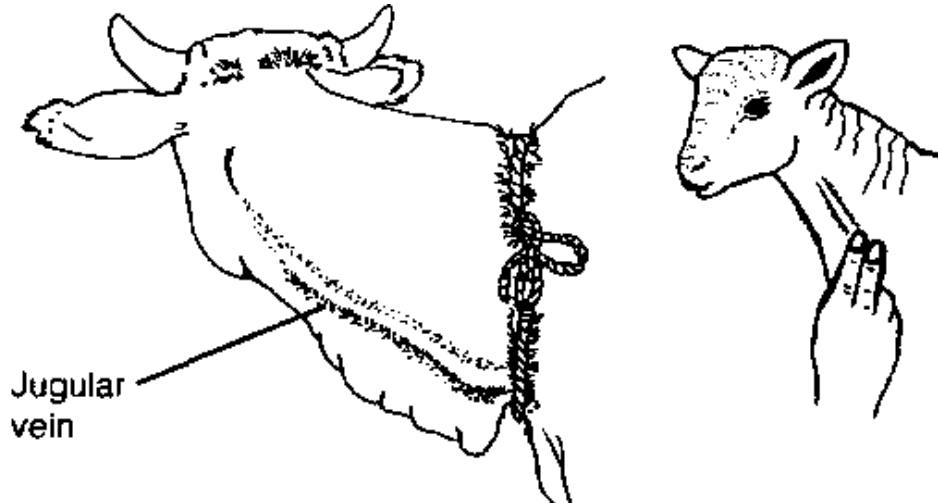

- **Subcutaneous injection**

**This means injecting under the skin. It is done by picking up a loose fold of skin from the neck or shoulder. Take care not to inject into your fingers or that you push the needle in so much**

**that it comes out on the other side of the skin fold.**

### **Subcutaneous injection**

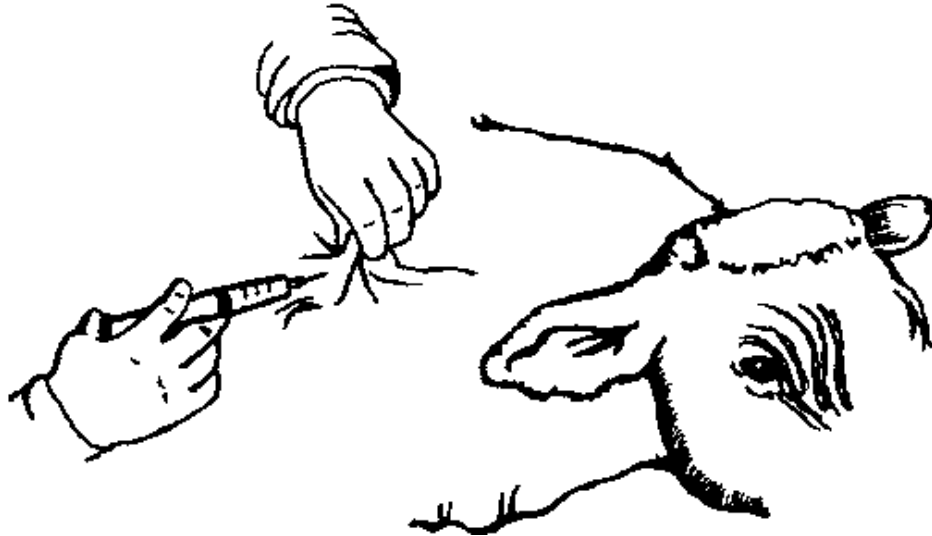

- **Intramammary injection**

**Used to empty antibiotics in an intramammary tube into the udder or to put drugs into the udder using a teat catheter (see Unit 22).**

## Intramammary injection

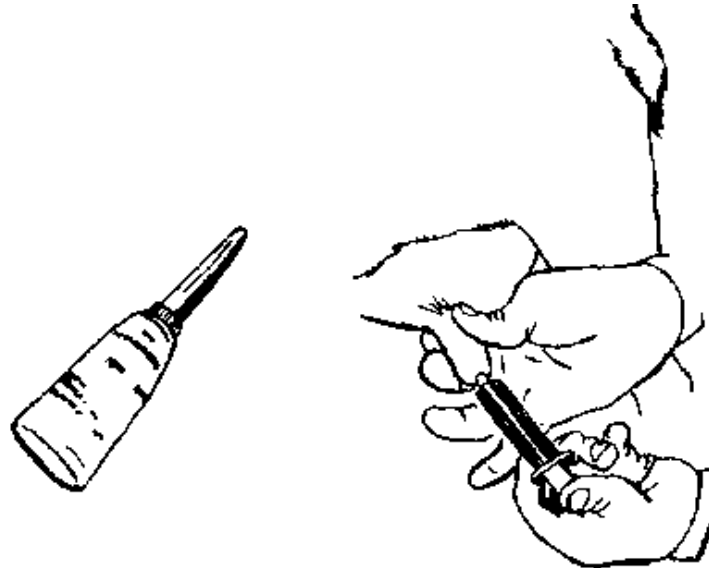

**Remember that before you make any injection you should:**

- **Pick an area of skin free from faeces or mud**
- **Use a clean sterilised syringe and properly fitted needle**
- **Make sure your hands are clean**

### **3. Vaccinations**

**Animals can be protected against some germs and diseases by giving them a vaccine. Vaccines are very important in stopping the spread of disease and are given by injection or by the mouth.**

**Some of the diseases discussed in this book, e.g. rinderpest, rabies, anthrax, African horse sickness and foot and mouth disease, can be prevented by vaccination. Some vaccines only need to be given once to the animal to protect it, but other vaccines, e.g. anthrax and foot and mouth disease, need to be given every year.**

**Talk to your veterinarian about the vaccines which are available and the way they must be given to the animals. You will also need to know how to keep the vaccine until it is used. Hot weather can spoil some vaccines and your veterinarian will advise you on keeping vaccines.**

**Remember when you vaccinate animals to change the needles after every few injections to prevent the spread of germs.**

**Talk to the people in your community and encourage them to vaccinate their animals. Keep records of all vaccinated animals (see Annex 5).**

.....

**Vaccine..... Rinderpest .....**

**Type (of animal)..... Cattle.....**

**Age of animal..... 6 months old.....**

**Frequency (No. of times to vaccinate)..... Once.....**

**Route (how to give vaccine)..... Subcutaneous injection .....**

Vaccine	Type	Age	Frequency	Route

## 4. Drenching

**Animals can be given medicine by drenching. Medicine is poured into the mouth from a bottle.**

**Drenching must be carried out carefully to make sure that the animal receives all of the medicine it needs and that none enters the lungs where it can cause respiratory problems or death.**

### **Drenching with a bottle**

**Prepare the drench to be given to the animal. The drench can be given from a bottle provided by the veterinarian or use a clean glass bottle (Pepsi or beer bottle). A short piece of rubber tubing (20 cm) can be attached to the mouth of the bottle. To drench large animals:**

- **Restrain the animal.**
- **Hold the animal's head so that it is level or only slightly**

**raised.**

- **Put the rubber tube into the mouth with the end of the tube or the bottle either on the middle of the tongue or in the cheek beside the teeth. Take care to avoid getting the glass bottle between the teeth when it could be broken.**
- **Pour the medicine in slowly, a little at a time, allowing the animal time to swallow the liquid.**

**If the animal coughs at any time allow it to lower its head and stop drenching when it is coughing. Take time to drench the animal. If a very large amount of medicine, such as more than half a litre, has to be given, it can take up to 15 minutes to give all of the drench.**

**Sheep and goats are more difficult to drench than cattle. They should be held so that their feet remain on the ground and the nose should be raised no higher than the eyes. Drench pigs and horses very slowly.**

**Sheep can be given a drench using a dose syringe or by using a rubber tube attached to a funnel.**

### **Drenching with a bottle**



## **5. Boluses (tablets)**

**Medicines can be given to animals as a bolus or tablets (pills). Large animals, e.g. cattle, buffalo and camels, can be given medicine in boluses, oval or round balls of the medicine. The bolus may sometimes be contained in a plastic container which stays in the rumen and the medicine slowly comes out over many**



**months. This type of bolus is used to give cattle drugs against worms in the gut. Sheep and goats can be given boluses (or capsules) by using a balling gun. A pig cannot be given a bolus as it has a sort of pocket in its throat in which the medicine can become trapped.**

### **The balling gun**

**A balling gun is a simple metal tube which is wider at one end to form a small container (head) in which the bolus is placed. A bar of metal or fixed rings are on the opposite side of the rod to allow the user to have a firm grip and to stop the tube being swallowed by the animal. A metal rod or plunger can be pushed through the hollow tube to push out the bolus when the balling gun has been pushed into the animal's mouth.**

### **Giving an animal a bolus**

**Giving a bolus with a balling gun is done by:**

- Place the bolus in the head of the gun.**

- **Restrain the animal to be treated and open its mouth.**
- **Put the balling gun way back into the mouth so that the head is placed behind the base of the animal's tongue.**
- **Push the plunger slowly to push the bolus out.**

**The animal should swallow the bolus immediately, but if it starts to choke or cough, lower its head so that the bolus drops out as it coughs.**

**Tablets may also be pushed over the back of the tongue by hand but you must take care not to be bitten. Wetting boli or dipping in oil makes them easier to swallow.**

### **Giving an animal a bolus**

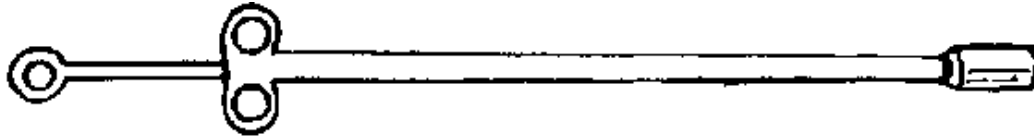

## 6. Stomach tubing

Large quantities of liquid medicine are mainly given through a long rubber tube directly into the stomach. A stomach tube can also be used in the case of bloat (tympany) to release gases from the rumen. There are different varieties of stomach tubes for animals of different sizes. You will need to practice this technique as there is a risk of the tube passing down the windpipe into the lungs and causing death of the animal.

**In order to stop the animal chewing the stomach tube you will need to put a metal pipe, or a block of wood with a hole in it, into the animal's mouth. Pass the stomach tube through the pipe or the wood into the stomach. Watch the animal carefully for signs of coughing. If the animal coughs the tube is in the lungs and you must take it out immediately.**

### **Stomach tubing**

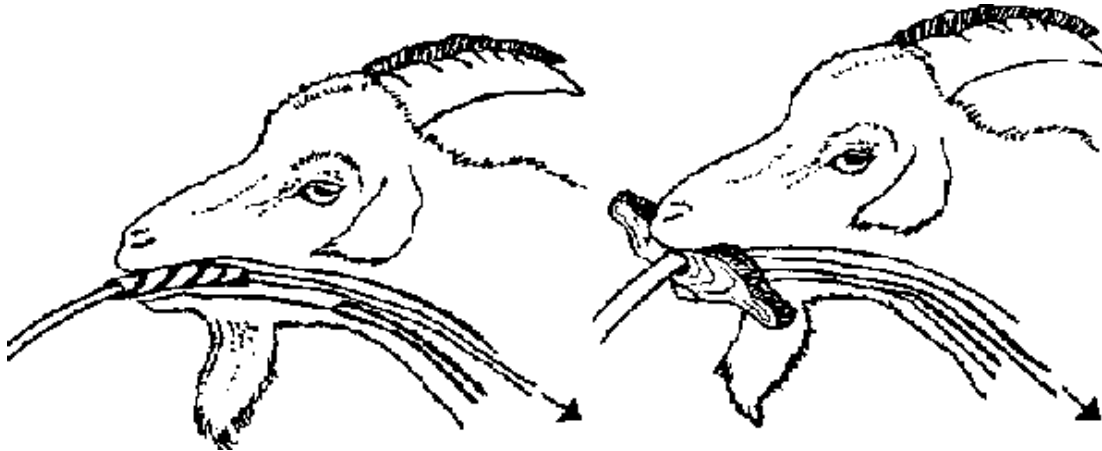

**If the animal does not cough smell the end of the tube and you**

**should notice the bad smell of stomach gases. When you are sure that the tube is in the stomach you can pour the medicine down the tube.**

***Do not use the stomach tube unless you have been trained to do it.***

## **7. Cleaning the udder**

**Many animals are kept for their milk. The value of any milk animal is reduced if it has mastitis. The condition of the udder and the cleanliness of the milk is very important for the well-being of not only the animal but also of the people who use the milk. Cleaning the udder and mastitis were described in Unit 22.**

**If mastitis continues in a group of animals it is advisable to use a teat disinfectant when milking them. A teat dip is a liquid in which the teat is dipped after milking the animal. After milking germs can pass into the udder through the teat canal. Dipping the teat in a disinfectant stops any germs from entering the udder and causing mastitis.**

**If mastitis is a problem in your community talk to your veterinarian about it. He can advise you on improving milking hygiene and the best disinfectant to use as a teat dip.**

### **Cleaning the udder**



## **8. Taking blood samples**

**You may be asked to send a blood sample to the veterinary laboratory. Your veterinarian will send to you a small, clean bottle with a tight-fitting cover for the blood. The bottle may have something in it, usually a liquid, which will stop the blood from clotting (getting thick).**

### **Collecting blood**

**Blood samples are usually taken from the large neck vein. In order to take the sample of blood you must find the vein as for an intravenous (i.v.) injection (see 2, Annex 3). However now:**

- **The syringe is empty, dry and the plunger is pushed right down to the end of the barrel.**
- **When you are sure that the needle is in the vein do not remove your hand or the rope which is blocking the vein.**
- **Slowly pull out the plunger until you have collected enough blood in the syringe (usually 5 - 10 ml).**

- **Put the blood straight into the bottle.**

***All blood samples must be kept in a cool place away from direct sunshine.***

**You may find that some people in your community will refuse to allow blood samples to be taken from their animals. You should explain to them that the whole community will benefit if the veterinarian can check their animals for diseases. Tell them that the small amount of blood taken is easily and quickly replaced by the animal's body.**

**Your veterinarian may give you a special tube, called a vacutainer, to collect blood. You must ask him to explain how you use this tube to collect blood.**

## **9. Making blood smears**

**Veterinarians need blood smears to check for some diseases. A smear is a very thin layer of blood, on a clean glass slide, from a live animal or one which has recently died. The slide can be**



**placed on a microscope and examined for the germs which cause diseases.**

## **Making a blood smear**

- **Restrain the live animal and find a blood vessel in its ear, clean the ear with alcohol or soap and water. Dry the ear.**
- **Pierce the blood vessel with a sharp, clean needle or knife point.**

## **Making a blood smear**

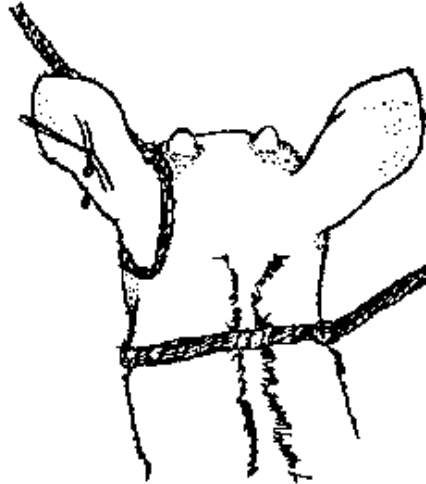

- **Collect one drop of blood on a clean glass slide and place the slide on a clean flat surface.**
- **Take another clean glass slide and touch the blood with one end of it so that the blood runs along the edge of the slide. Hold the second slide at an angle (45°) and push it along the length of the first slide to form a thin smear of blood.**

## Making a blood smear

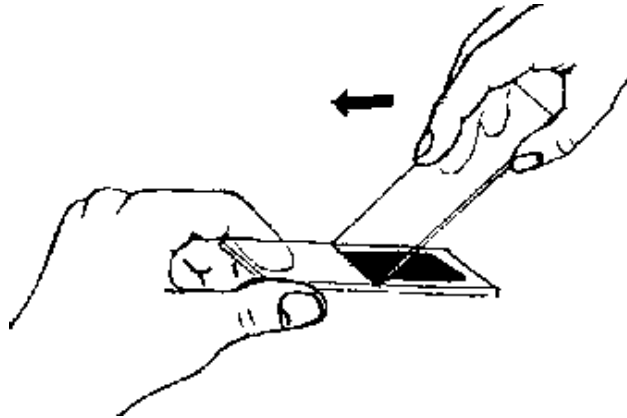

- **Allow the smear to dry. Take two smears from each animal.**

**Put the slides face to face with a matchstick at each end to keep the smears from touching. Wrap them carefully and take, or send them, to the laboratory.**

**In the laboratory the smear will be treated to make the germs easily seen under the microscope.**

## **10. Collecting samples for the laboratory**

**You may need to send samples to the veterinary laboratory so that the cause of a disease can be discovered. This is very important as the veterinarian can then tell you the best treatment and how to prevent the disease spreading. It is important that the samples are properly collected and sent to the laboratory so that the right checks can be made.**

**Collecting blood and making blood smears has been mentioned previously (see 8, 9 Annex 3).**

**To collect other samples you will need special wide-mouthed containers and a preservative (liquid to keep the sample from going bad). The type of preservative will vary according to the type of sample. Check with your veterinarian about containers and preservatives to use and if the samples should be kept cool or at normal temperatures.**

**Samples which can be collected are:**

- **Skin scrapings to check for external parasites. The scrapings are put in glycerine.**
- **Pus from lumps and wounds.**
- **Milk to check for germs causing mastitis.**
- **External parasites such as ticks, lice, fleas and fly maggots.**
- **Parasites such as tapeworms, flukes and roundworms which you may find in fresh faeces or in a dead animal.**
- **Faecal samples.**

**Your veterinarian may want samples from inside the body of a dead animal:**

- **Pieces of lung, liver, kidney or brain.**
- **Pieces of the intestine or the contents of the stomach.**

**Mark (label) samples with information such as date, number or identity of animal, age, owner's name, the region, village or community, etc.**

## **11. Collecting faecal samples**

**Your veterinarian may ask for samples of faeces (dung) to be collected and sent to the laboratory. Place the sample in a clean wide-mouthed container.**

**Samples can be collected by:**

- **Collecting by hand from inside the rectum of the animal.**
- **Collecting dung from the ground as soon as it is passed by the animal.**

**Mark (label) the samples and keep them in a cool place.**

## **12. Spraying**

**In some countries animals are sprayed with treatments against external parasites and are not dipped. Spraying can be as good as dipping. The system uses less water and drug treatments but the equipment and the engines, generators, etc. are more expensive and must be maintained. Power spray systems can only be operated using liquid treatments in water, not powders**

**dissolved in water.**

**Hand spraying can be carried out. It takes time and is not quite as good as dipping or power spraying. However it is a useful way to treat animals if no dip is available. To try to treat more than 10 animals at a time is not a good idea because of the time and amount of drug treatment used. Spraying can be used to treat pregnant animals which cannot be dipped.**

### **Equipment for hand spraying**

**Hand spraying can be carried out using any type of hand pump or means of applying the treatment all over the animal.**

**Spraying by hand must be done thoroughly in order to be useful. All parts of the animal will need to be treated. The animals should be tethered or tied up securely between posts or held in a crush or race. All parts of the animal should be sprayed as follows:**

- **Hooves, under the tail and down to the scrotum or udder and the inside of the back legs should be**

**thoroughly wetted.**

- **Then spray the belly, sides and back, and spray the outside and insides of the front legs and up under the brisket.**
- **Lastly spray the head and neck making sure that inside the ears is also sprayed.**

**Your veterinary officer will advise you on spraying your animals, what to use and how to do it. You must remember that the spray solutions are poisonous and you should take great care when using them. Your veterinarian will advise you on this and you must follow his instructions carefully. Never throw away left over spray solution where children can find it or where it may reach a water supply or river. It is poisonous to children, animals and fish as well as you.**

### **13. Dipping**

**Dipping is the most efficient and practical way of treating**



**ruminants for skin parasites. Your community or area may already have a tank for dipping which you can use or the veterinary service may have a mobile dip tank which can be taken to your community when needed. Your community may decide to construct a tank. You will need to talk to your veterinary officer for advice on what to treat animals with and how to use the tank. He will also be able to advise you on how to construct a tank.**

### **The dipping tank**

**The animals are first collected in a collecting pen. They are then driven into a narrow passageway (race) which is too narrow for them to turn around. In the race is a footbath (trough of water) through which the animals walk. This removes mud from the feet before they enter the tank.**

**The animals are forced forward into the tank and are completely dipped in the treatment it contains. The animals walk out of the tank along another passageway (race) which has a sloping concrete floor to allow all solution dripping off the animals to run back into the tank. This race is only wide enough to take one**

**animal at a time and can be fitted with gates to allow animals to be held and marked or given individual treatment.**

**The dip should have a roof to protect it from rain. It should be well fenced around so that animals cannot get at it.**

### **The dipping tank**

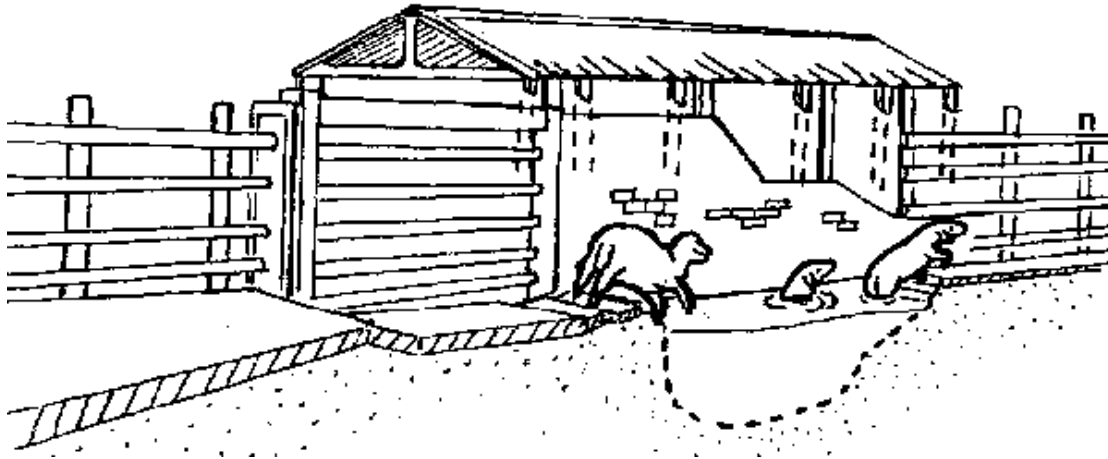

### **How much dip to use**

**For large numbers of cattle a tank that will hold 13,500 to 16,000 litres will be needed. For smaller numbers of animals a tank holding 9,000 litres will do.**

**When the tank is filled, the capacity (volume) of the tank can be worked out by counting the number of drums, of a known size, used to fill the tank with water. Mark the wall at intervals, or use a measuring stick, to show the amount in the tank. Add the correct amount of dip treatment to the water.**

**After the dip tank is used you will need to record the amount of dip left in it. Water can be lost from the tank in hot weather or rain will make the level rise. Before the tank is used again you will need to check the level of water and dip in the tank. You will need to add water and the correct amount of dip to bring the volume to the correct level again.**

### **Using the dip**

**When using the dip you should always remember:**

- **Do not dip on cold or wet days.**
- **Do not dip animals when they are hot or they may drink the dip. Keep the animals in the collecting pen and allow them to drink before they are dipped.**
- **Always make sure that the head of each animal is pushed beneath the surface of the water and completely covered.**
- **Do not keep dipped, wet animals standing around. Allow the dip to drain off then move them to pasture.**
- **Periodically test the concentration of dip in the tank and keep it at the correct strength.**
- **Care should be taken to allow animals to enter and leave the tank one at a time. If they struggle to leave the tank some may be pushed under and drown.**
- **Do not dip small and large animals together as the**

**larger ones can jump onto smaller ones and push them under.**

- **Do not dip pregnant animals that are close to giving birth. Help young animals through the tank using a crooked stick.**
- **Keep the footbath and races clean, clear waste material (e.g. straw) off the top of the dip after it is used.**
- **Always completely clean out the dip tank once or twice a year.**
- **Keep a record of the animals which have been dipped (see Annex 5).**

**Always remember that the treatments you use can be poisonous to your animals and you if they are not used properly. Be careful when you use these treatments. Your veterinary officer will advise you when to treat your animals, what treatment to use and how to do it correctly. Always follow his advice on handling**

**the treatments and how you can get rid of the waste.**

**If dip solution gets into a water supply used by animals it can cause their deaths by poisoning. If it gets into rivers, streams or ponds it will kill any fish there.**

## **14. Knots and tethering**

**A tether is the rope or chain by which an animal is tied. Ropes are used to tie up animals, to cast them and to confine them to one place.**

**It is important to keep a length of rope to use in your work and you must have some knowledge of the type of knots which are used to tie up or cast animals.**

### **Non-slip knots**

**This type of knot is used to tie an animal with a rope around the neck or its legs. This knot will keep the rope around the neck or leg fixed and will prevent the rope from becoming tight and hurting the animal. It is also used around the neck of cattle when**

**they are cast.**

### Non-slip knots



Non-slip knot

### Safety knot

**Use this knot when you want to be able to quickly release a knot.**

**Pulling the free end of the rope will quickly free the animal. Use it to tether horses or to tie together the legs of an animal which has been cast.**

### Safety knot

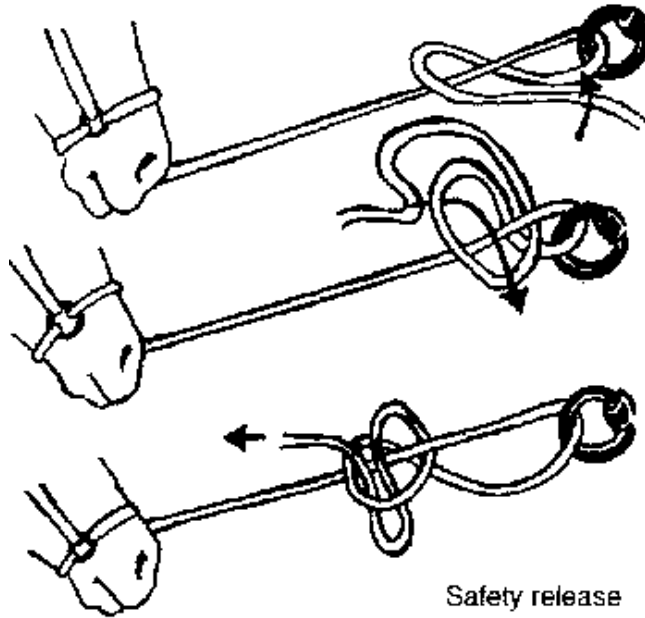

### Double loop



**This is used to make a loop in the end of a rope when making an halter to put around the head of an animal. It is also used when a rope is put around the horns of an animal to control it.**

### Double loop

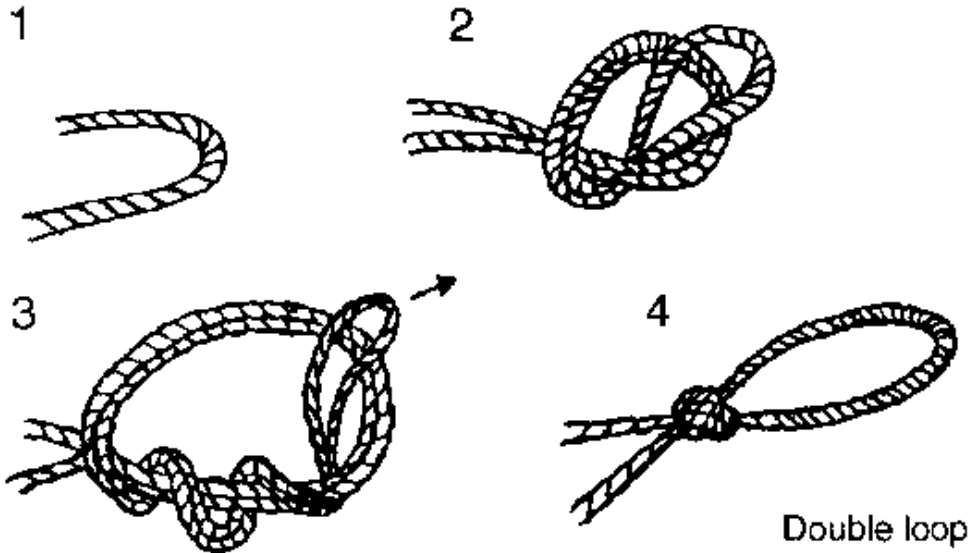

### Tying two ropes together

**Use this when you need to join two lengths of rope together. The two ropes are held together and a loop is made towards the ends. The free ends of the rope are then passed through the loop four times and the knot is pulled tight. The ends of rope at the knot can then be cut.**

### Tying two ropes together

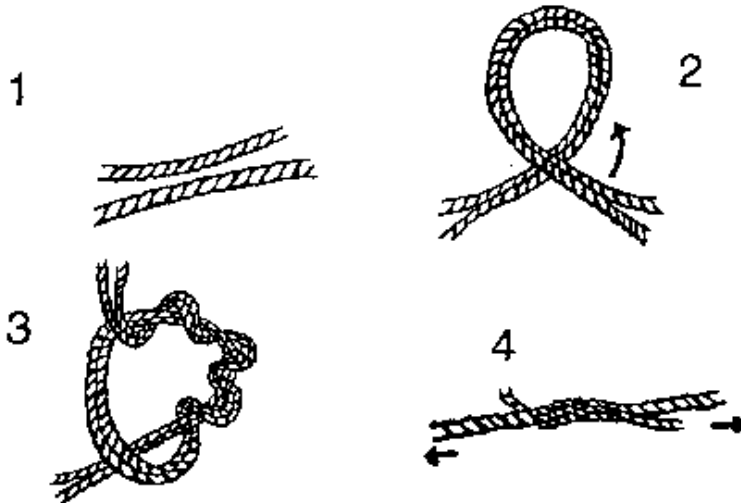

### Rolling hitch

**This knot is useful when tying a rope to a Pole. It will not slip downwards.**

### Rolling hitch

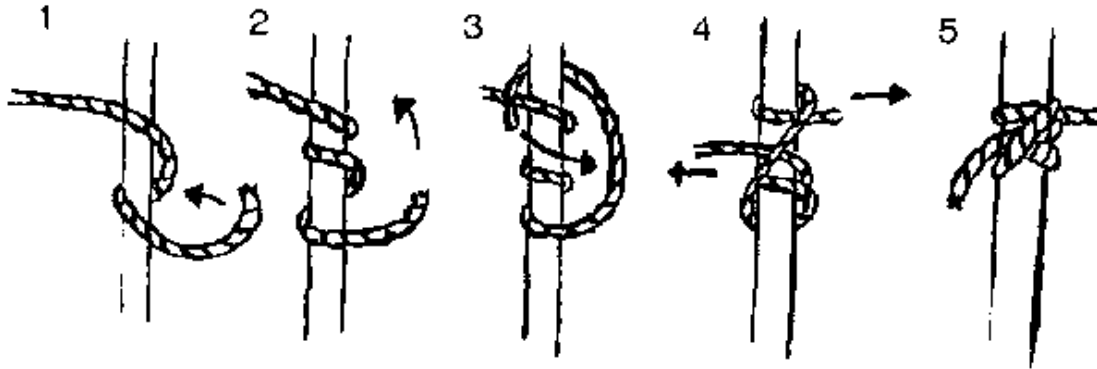

## Annex 4: Selection of animals for breeding

### Breeding animals

**All animals used for breeding must be fit and healthy. Good and bad qualities can be passed from the parents to the young. This is called heredity and the young will inherit characteristics from**

**both the parents.**

### **Why select animals for breeding?**

**The young animal will have the same characteristics (qualities) as its parents. Carefully choosing animals for breeding means that good, useful young animals are produced.**

**Animals which produce good quantities of milk can pass this characteristic to their young. Cattle and sheep which quickly grow big and fat can produce calves and lambs with the same characteristics. Selecting good males and females is the means of improving the quality of livestock in the future.**

### **Selecting animals**

**The easiest way to improve your animals is by selecting a good male. In this way good characteristics can be quickly spread through the herd.**

**If you have ten cows and one of them is good she will produce one good calf each time she is used for breeding. If you breed the**

**ten cows with a good bull each cow can produce a good calf. So selecting a good male will improve the quality of your herd more quickly.**

**When selecting animals for breeding you should take into consideration the following points:**

### **1. Body shape**

**The shape of the body must be considered when choosing animals for breeding:**

- **The animal should be well built and its body well proportioned and muscled. The muscles of the back will give you a good idea of the animal's condition.**
- **Animals with any type of deformity (bad shape) should not be used for breeding as many of the deformities can be inherited by the young. Animals with badly shaped jaws or teeth cannot be selected as this can be inherited and will mean that the animal cannot eat properly.**

## **Badly shaped jaws**



### **2. Legs of the animals**

**Good legs and feet are important so that the animal can get around to feed. The legs of the female will have to carry extra weight during pregnancy. The male will have difficulty in**

**mounting the female if its back legs are weak.**

### **3. Reproductive organs of males**

**The testicles and penis of the male must be correctly formed and free from deformities and infection. The testicles must be:**

- **Equal in size.**
- **Both testicles should be down in the scrotum. Do not use a male in which only one testicle is down in the scrotum.**
- **The larger the testicles the better.**
- **The testicles must be firm and not soft.**

**The penis of the sheep or goat can be examined by holding the male in the sitting position, as for trimming the feet. The skin around the penis can be held in one hand and the end of the penis pushed out by pushing upwards with the other hand from the base of the penis. If blood, pus or a discharge is seen, or if**

**the penis is unusual, do not use the animal for breeding as this will spread disease to the rest of the livestock.**

#### **4. What are the animals used for?**

**When selecting cows, buffalos and other animals for milk production you should select females which have good udders and teats and are docile. Docile animals let down the milk more easily than others. The amount of milk produced after the birth of the first young is important in judging the quality of a milking animal. A good male to father milk animals will be one which had a good milking mother.**

**When breeding animals for meat the rate at which they gain weight is an important characteristic to consider. Animals used for work should be strong, with good feet and legs and need to be docile. The parents need to show these characteristics.**

**The ability of the female to feed and wean her young is also important. This is an essential factor to consider when breeding pigs.**



***If you can keep a record of your animals you will know which ones were good for milk, meat, producing young and staying healthy. You can also keep a record of the parents.***

***If you keep records it will help you to judge which animals to keep for breeding and which males to castrate.***

***You must remember never to breed between father and daughter. This will increase the chances of any bad characteristics of the male being passed on to the young. This is called inbreeding.***

## **Annex 5: Record keeping**

**Why do we keep records?**

**As a PAHCW you may well know a lot about the animals kept in your community. However keeping the information in your memory is not enough, we can all easily forget something. You must be able to supply your veterinary and livestock officers with written papers (records) about the animals in your community.**

**You will need to keep records to tell you when animals were vaccinated, dipped, given any medicine or castrated. You need to know how many animals were treated, what was the problem and how often do some diseases occur in your community.**

**If you want to breed your livestock to improve them then you will need to keep records of the father and mother of every animal. You need to know how good they and their young were (see Annex 4).**

## **Records**

**Papers for records may be given to you by the veterinarian, livestock or agricultural officer for your area. They will want you to fill in the records with information about livestock in your community.**

**If you do not have these record papers you can make your own. You only need a pencil and paper. You should remember that you and your community will gain the most from record keeping.**

## **Types of records**

**These are examples of the types of records you need in your work:**

- **Recording your work in the community**

**It is important that you keep a register (note book) to write a record of your work:**

<b>Date</b>	<b>Name of owner</b>	<b>Age &amp; Type of animal</b>	<b>Problem</b>	<b>Action taken</b>

- **Vaccination record**

**You can keep this as a separate register or as a separate record in your notebook.**

<b>Date</b>	<b>Vaccination</b>	<b>Type of animal</b>	<b>Number of animals</b>	<b>Name of owner</b>

- **Records for the veterinary officer**

**You may have to give your veterinary officer records of what you have been doing in your work.**

**Name of District or Community .....**

**Name of PAHCW ..... Date .....**

**Work done by PAHCW from ..... to .....**

**1. Number of sick animals seen .....**

**Details .....**

**2. Drugs used:**

**3. Number of animals vaccinated and vaccines used: .....**

**4. Number and type of animals dying .....**

**5. Other problems seen by PAHCW:**

**6. Other activities and comments: .....**

<p>.....</p> <p><b>Signature of PAHCW .....</b></p> <p><b>Supervisor's comments .....</b></p> <p>.....</p>
--

- **Records for the animal owner**

**You should encourage everyone who keeps animals to keep a record of their animals. Encourage them to use numbers, names or ear tags to identify their animals. If the owner keeps records of his animals he will be able to identify the good animals and breed from them and similarly he can identify the poor animals and get rid of them.**

**This is an example of a record for a male animal:**

**name/number of male**

**date of birth**

.....

.....

**name/number of father**

.....

**name/number of mother**

.....

## **Mating**

- |                                 |                        |
|---------------------------------|------------------------|
| <b>1. Name/number of female</b> | <b>date and result</b> |
| <b>2. Name/number of female</b> | <b>date and result</b> |
| <b>3. Name/number of female</b> | <b>date and result</b> |

### **Example of record for a female animal:**

<b>Name/number of female</b>	<b>date of birth</b>
------------------------------	----------------------

.....

.....

**name/number of father**

.....

**name/number of mother**

.....

### **First mating**

**name/number of male**

**date of mating**

**number born**

**number weaned**

**Second mating****name/number of male****date of mating****number born****number weaned****Annex 6: Weights and measures**

Throughout the world different terms are used for measuring weight, length and volume. The following tables give the terms which you may need to know in order to work out how much medicine to give animals.

**Metric weights and measures**

<b>Weight:</b>	<b>1 tonne</b>	<b>= 1,000 kilogram</b>
	<b>1 kilogram (kg)</b>	<b>= 1,000 grams (gm)</b>
	<b>1 gram (gm)</b>	<b>= 1.000 milligrams (mg)</b>
<b>Volume:</b>	<b>1 litre (L)</b>	<b>= 1,000 millilitres (ml)</b>



<b>Length:</b>	<b>1 metre (m) = 100 centimetres (cm)</b>
----------------	---

## Imperial weights and measures

<b>Weight:</b>	<b>1 stone = 14 pounds (lbs)</b>
	<b>1 pound (lb) = 16 ounces (oz)</b>
<b>Volume:</b>	<b>1 pint (pt) = 20 fluid ounces</b>
	<b>1 quart (qt) = 2 pints</b>
	<b>1 gallon = 4 quarts</b>
<b>Length:</b>	<b>1 foot (ft) = 12 inches (ins)</b>
	<b>3 feet (ft) = 1 yard (yd)</b>

## Imperial and metric equivalents

<b>Imperial</b>	<b>Metric</b>
<b>2.2 pounds</b>	<b>1 kilogram</b>
<b>1 ounce</b>	<b>31.1 grams</b>
<b>1 pint</b>	<b>473.2 ml</b>
<b>1 quart</b>	<b>946.4 ml</b>

<b>1 gallon</b>	<b>3,785 ml</b>
<b>1 inch</b>	<b>2.54 cm</b>
<b>1 foot</b>	<b>30.5 cm</b>
<b>1 yard</b>	<b>91 cm</b>

### Useful household measurements

<b>1 teaspoon =</b>	<b>5 ml = 60 drops = 3 gm of flour = 5 gm of salt</b>
<b>1 tablespoon =</b>	<b>15 ml = 3 teaspoons = 15 gm of salt</b>
<b>1 wineglass =</b>	<b>60 ml = 4 tablespoons</b>
<b>1 cup =</b>	<b>250 ml</b>

### Land

**1 hectare = 2.471 acres = 10,000 square metres**

### **Annex 7: Explanation of terms and index**

### **A**

**abattoir: a slaughterhouse where animals are killed for meat.**

**abdomen: the belly.**

**abomasum: the fourth stomach of ruminants, the true stomach.**

**abortion: the end of pregnancy before the young can survive.**

**abscess: a painful lump full of pus.**

**absorb: to take in.**

**acute disease (Unit 6): a disease which quickly develops and from which the animal can die or recover.**

**African horse sickness (Unit 48): an infectious disease of horses which can kill.**

**afterbirth: the flesh which attached the young inside the womb and is expelled from the womb after the mother gives birth.**

**alfalfa: a green legume plant grown for animal feed.**

**anthrax: an infectious disease of cattle and sheep which can be passed to humans. It can kill animals and humans.**

**antibiotic: a medicine which can kill germs.**

**antiseptic: preventing infection by killing germs.**

**anus: the opening at the end of the gut through" which the faeces pass.**

**appetite: the desire for feed and drink.**

**ark (pig ark): a wooden shelter for pigs.**

**arteries: the vessels or tubes which take blood away from the heart.**

**artificial insemination (Unit 17): semen taken from the male is introduced into the uterus of the female.**

**arsenic: a poison used for killing pests.**

**ash: the powder formed when something is burnt.**

## **B**

**barley: a grasslike plant grown for grain.**

**bedding: straw or other material for animals to lie on. Can be used as a feed (see Unit 23).**

**belch: to bring up gas from the stomach through the mouth.**

**bile: greenish fluid produced by the liver.**

**bladder: bag in which the urine collects.**

**blister (Unit 25): bubble of skin in which water collects.**

**bloat (Unit 8): swollen with gas.**

**blood smear: small amount of blood from an animal, dried onto a glass slide, which is sent to a laboratory for checking.**

**blood vessels: tubes throughout the body which contain the blood.**

**blowflies (Unit 12): flies that lay their eggs on meat and wounds.**

**boar: a male pig.**

**body brush: a brush used to remove dirt and dust from the animal's coat.**

**bolus: a ball or tablet of medicine.**

**botfly (bots)(Unit 41): fly maggots which live in the stomach of equines.**

**bran: husks of cereal grain separated from the flour.**

**breast girth (Unit 47): a band around the chest of a horse to prevent the saddle or harness slipping off.**

**breed: a group of animals with the same characteristics.**

**breeding: the controlled reproduction of animals.**

**bridle (Unit 47): harness on the horse's head used to control the horse's movement.**

**brisket: breast muscles of the cow, buffalo, horse.**

**browse: to eat plants and leaves.**

**Burdizzo (Unit 14): instrument for castrating cattle, sheep, goats and buffalo.**

## **C**

**caecal worm: parasitic roundworm in the gut of chickens.**

**calving (Unit 19): when a cow gives birth.**

**cake (Unit 23): material left after the oil has been removed from sesame seeds, groundnuts, linseed, etc.**

**canine: like a dog, the sharp pointed teeth.**

**capillaries: very fine blood vessels.**

**carbohydrate: food such as sugar and starch which contains a lot of energy.**

**carbon dioxide: colourless gas formed in breathing.**

**carcass: the dead body of an animal.**

**carnivores: animals which eat meat.**

**cartilage (gristle): material found in the joints.**

**cast: to throw down, to pull an animal off its feet.**

**castration (Unit 14): removal of the testicles.**

**cattle plague (Unit 25): infectious disease of cattle (rinderpest).**

**caustic soda: a chemical which burns.**

**cauterise: to treat a wound by burning with an hot iron.**

**cells: smallest piece of substance from which all plants and animals are formed.**

**centigrade (°C): scale of temperature, water freezes at 0°C and boils at 100°C.**

**characteristic: a distinguishing feature or quality.**

**chronic disease (Unit 6): a long-lasting, lowly progressing disease.**

**circulatory system (Unit 3): the heart, blood vessels and blood.**

**claw of hoof: hard part at the end of the hoof.**

**climate: the temperature and weather conditions.**

**cloaca: the cavity into which the gut and the reproductive organs open in birds.**

**clover: a green legume plant with three-lobed leaves used for animal feed.**

**coat: the hair, wool or fur of an animal.**

**coccidia: small parasites of the gut.**

**coccidiostat: medicine to slow down the development of coccidia.**

**colic: severe cramping pains of the stomach.**

**colostrum: the first milk produced after birth**

**comb: fleshy crest on the head of chicken**

**community (Unit 1): any group of people living together.**

**concentrate feed (Unit 23): an animal feed rich in nutrients, especially protein and energy.**

**constipation (Unit 68): the faeces are hard and difficult to pass.**

**contract: to shorten.**

**cornea: the outer covering of the eyeball.**

**cough: expel air quickly and noisily from the lungs.**

**creep: low area for feeding which piglets can enter but the sow cannot.**

**creosote: liquid used to preserve wood or as a disinfectant.**

**crush: metal or wooden crate in which animals, usually cattle, can be held or controlled.**

**cud: partially digested food brought up from the rumen and chewed.**

**curdle: to make milk separate into solids and fluids.**

**curry comb: a metal comb used to clean a body brush when grooming horses.**

**cyst: a bag which contains fluid, diseased material or tapeworm parasites.**

## **D**

**dagging (crutching)(Unit 12): removal or dirty, wet wool from around the tail and hind legs of sheep.**

**defecate: to pass faeces.**



**deficiency disease: a disease resulting from the lack of an essential nutrient.**

**deformity: part of the body which is badly shaped.**

**dehorn (Unit 13): to remove the horns from an animal.**

**diamond skin disease (Unit 29): erysipelas, a disease of pigs and humans.**

**diarrhoea: watery faeces which are frequently passed.**

**digestive system (Unit 3): the gut and associated organs.**

**disease: an illness or sickness.**

**disbudding (Unit 13): removal of the small horns from young animals.**

**discharge: an out flow of fluid or material, usually from the eye or ear.**

**disinfectant: a chemical used to kill germs.**

**dislocation: displacement of a bone at the joint from its normal position.**

**docking: cutting the tail short, especially in sheep.**

**draught: the act of pulling a load by an animal, as in a cart or plough.**

**drench: liquid medicine given by mouth to an animal.**

**droppings: the faeces of birds and small animals.**

**dung: the faeces of large animals.**

**dust bath: the act of covering the coat or feathers with dust.**

## **E**

**ear tagging (Unit 36): marking the ears of an animal to identify it.**

**elastrator (Unit 14): instrument used to place rubber band around the base of the testicles in castrating small ruminants.**

**emasculator (Unit 44): instrument used to castrate horses and other equines.**

**embryo (Unit 3): the developing young animal inside the uterus.**

**energy: the capacity for activity or function.**

**environment (Unit 2): the conditions and surroundings in which people and animals live.**

**erosion: the wearing away of rocks and soil by the action of water and wind.**

**equine (Unit 5): relating to the horse, one of the horse family.**

**erysipelas (Unit 29): disease of pigs causing diamond-shaped patches on the skin.**

**expiration: the act of breathing out.**

**external parasite: parasite which lives on or in the skin, hair, wool**

**or fur for all or part of its life, such as ticks, lice.**

## **F**

**faeces: waste material left after digestion.**

**farrowing: name given to the act of giving birth in the pig.**

**fat: greasy or oily substance.**

**fetlock joint: the joint just above the hoof in equines.**

**fever: a very high body temperature caused by an infection.**

**first aid: treatment given to wounds or in an emergency.**

**flank: the side of the abdomen.**

**fleas: small external parasites found in the coat, bedding and housing of animals.**

**fleece: the wool of sheep.**

**flesh: the meat of the body.**

**flukes (Unit 15): flat, leaf-like parasites found in the liver or rumen.**

**foaling: the act of giving birth in the horse.**

**foot and mouth disease (Unit 25): infectious disease of cattle, causes blistering of mouth, feet and teats.**

**foot rot (Unit 11): disease of the underside of the hoof.**

**foreign body: any object not normally found in the body.**

**forceps: instrument in the form of a pair of pincers.**

**formalin: a chemical used as a preservative.**

**foster: to care for and rear the young of another.**

**foster mother: a female which feeds and cares for the young of another.**

**fracture: a broken bone.**

## **G**

**gait (movement): the way in which a horse (or other animal) moves.**

**Galvayne groove (Unit 38): a groove in the corner front tooth of the horse, first appears at 10 years of age.**

**Gentian violet: a violet coloured chemical used to disinfect wounds.**

**germs: the very small organisms which cause diseases.**

**girth (Unit 47): the band passed around the belly of the horse to hold the saddle in place.**

**girth gall (Unit 47): painful area of skin caused by a badly fitted girth.**

**gizzard: thick-walled part of the gut in birds.**

**gizzard worm: parasitic worm living in the wall of the gizzard.**

**grain: the seeds of grass-like plants, e.g. barley, wheat.**

**grit: small hard pieces of stone or earth.**

**groom: to brush and clean the coat of an animal.**

## **H**

**halter: rope or leather headgear used on horses or other animals to handle them.**

**hand rear: to feed a young, orphaned animal with milk.**

**harness: the arrangement of straps fitted on a horse to attach it to a cart or other object for it to pull.**

**hay: sun-dried grasses used as animal feed.**

**heat (oestrus): when the female will accept the male.**

**heifer: young cow which has not given birth.**

**herbivores: animals which eat plants.**

**herd: large group of animals.**

**hereditary: characteristics passed from parents to young.**

**heredity: the passing of characteristics from parent to young.**

**hobble: to tie the legs of a horse or other animal to prevent it**

**walking away.**

**hock: the large joint of the hind leg.**

**horse collar (Unit 47): leather or wood and leather collar fitted around the neck of a horse used to pull a cart.**

**hormones: chemicals formed by glands in the body which control the activity of organs.**

**hoof, hooves: the horny covering at the end of the foot in animals.**

**hoof pick: tool used to clean out the hoof.**

**host: an animal which is infected with parasites.**

**hydatid cyst: cysts formed in the organs of ruminants and people by the young of a tapeworm from dogs.**

**I**

**identification: recognition, e.g. permanent name, number, tag or mark on animal.**

**immunity: an animal's cellular and chemical (antibody) protection against germs or cancer. Immunity can be produced by vaccination.**

**infection: disease caused by a germ.**

**injection: to put a fluid into the body using a needle and syringe.**

**inspiration (Unit 3): breathing in.**

**internal parasite: parasite which lives inside the body for all or part of its life, such as roundworms, lungworms and coccidia.**

**intramammary: into the udder.**

**intramuscular: into the muscle.**

**intravenous: into the vein.**

**iodine: a brownish chemical used to clean and disinfect wounds.**

**isolate: to separate from others, e.g. sick animals from healthy ones.**

## **J**

**joint: the point where two bones are joined.**

**juices: liquid which occurs naturally in plants or animals.**

## **K**

**kaolin: a fine white clay used to treat diarrhoea.**

**kidding (Unit 20): the name for giving birth in the goat.**

**kidneys: the organs of the body which form urine.**

**L**

**lambing (Unit 20): name used for giving birth in sheep.**

**lame: unable to walk properly.**

**laxative: substance which stimulates defecation.**

**legume: certain plant species which fix (produce) nitrogen in the soil, i.e. clover, lucerne**

**leguminous: relating to any flowering plant which fixes nitrogen**

**lesion: injury to or abnormal tissue or loss of function of a body part. Cut skin, TB tubercles in the lungs and mastitis are all lesions.**

**lice (louse): small external parasite found amongst the hairs of the coat.**

**ligaments: tough fibres which connect bones together at the joints.**

**limb: a leg or wing.**

**litter: a group of animals born at the one birth.**

**livestock: domesticated animals.**

**loose box (Unit 45): stable in which a horse is able to turn around in and is not tethered.**

**lucerne (Unit 8): alfalfa.**



**lungworm: parasitic worm which lives in the lungs.**

**lymph gland or node: small gland which helps to protect the body against disease.**

**lympho-reticular system (Unit 3): tissues throughout the body which help protect from germs through immunity.**

## **M**

**maggot: the young stage of a fly.**

**maize: grass-like plant grown for its yellow grains.**

**mange: infection of the skin caused by mites.**

**mare: female horse.**

**marshy: badly drained, wet and muddy land.**

**mastitis (Unit 22): infection of the udder.**

**mating: the joining of the male and female to breed, mounting.**

**meal: ground grain.**

**mercury: silver coloured liquid used in thermometers.**

**microscope: magnifying instrument used to see objects too small to be seen with the naked eye.**

**milk teeth: the first or temporary teeth.**

**milk spot: white spots on the liver caused by infection with**

**roundworms.**

**minerals: naturally occurring chemical substances.**

**mites: small external parasites found in the skin, coat and ears.**

**mounting: mating.**

**mucous: slimy material formed to protect parts of the body e.g. the nostrils.**

**mud fever: infection of the legs of equines kept in wet and dirty conditions.**

**mulch: rotting leaves and used to protect the roots of a plant and to fertilise the soil.**

**muscles: the meat of the body. Contraction of muscles makes the body move.**

**musty: smelling or tasting old.**

**muzzle: sensitive area around the nose and mouth.**

## **N**

**navel cord: cord which attached the young to the placenta in the womb.**

**newborn: recently or just born animal.**

**nerves: fibres which carries messages between the brain and the**

**rest of the body.**

**nervous system: the brain, spinal cord and nerves.**

**nicotine: poisonous substance found in tobacco.**

**nose holder tongs: instrument used to control cattle and buffalo.**

**nostril: one of the openings in the nose.**

**notching (Unit 36): making cuts or marks in the ear of the animal to identify it.**

**nozzle: a spout from which fluid can be discharged.**

**nutrient (Unit 23): a food substance such as carbohydrate, fat, vitamins.**

## **O**

**oesophagus (gullet): the tube between the mouth and the stomach.**

**oestrus (Unit 17): when the female will accept the male and mate.**

**ointment: creamy or oily substance used on the skin, eyes or wounds.**

**omasum: one of the four stomachs of ruminants, also called the book.**

**omnivores: animals which eat plants and meat.**

**organ: part of the body which carries out a particular task.**

**orphan (Unit 21): young animal whose mother has died.**

**ova: the egg formed by the ovary.**

**ovary: the organ in the female which produces the egg or ova.**

**overgrazing: when pasture grasses have provided feed for too many animals for too long and becomes damaged or destroyed by loss of grass and soil.**

**overstocking: keeping too many animals in an area.**

**oxygen: colourless gas taken into the body during breathing.**

## **P**

**PAHCW: primary animal health care worker.**

**panting: breathing rapidly through the open mouth.**

**paraffin: kerosene, oil used to burn for light or heat.**

**paralysed: unable to move, having no control over the limbs.**

**parasite: animal or plant which lives in or on another.**

**parturition: giving birth.**

**pastern bone: the part of the leg of a horse (or equine) between the hoof and the fetlock.**

**pasture: area of grassland used for grazing.**

**pasture rotation: system of resting pasture for a time between grazing with animals.**

**pawing: scraping or hitting the ground with the foot.**

**pedal bone: one of the bones of the foot in equines.**

**pen: small fenced area for animals**

**pig ark: wooden or metal shelter in a field for pigs.**

**pig board: large wooden board used in moving or handling pigs.**

**piglet: young pig.**

**pigsty: house and pen for pigs.**

**pig swill: boiled feed for pigs.**

**plague: infectious disease, usually spreading rapidly infecting many animals.**

**pliers: strong tool used for cutting.**

**ploughing: cutting or turning over the soil.**

**poultry: domesticated birds.**

**post mortem: after death, examination to discover the cause of death.**

**pregnancy: the development of the young inside the mother.**

**pregnant: having developing young in the womb.**

**protein: an essential nutrient, important for good growth.**

**pus: white, grey or yellow fluid from an infected wound or**

**abscess.**

## **R**

**rabid: mad, having rabies.**

**rabies (Unit 77): infectious disease causing madness, fear of water and death.**

**race: fenced passageway, too narrow for an animal to turn around in.**

**rain scald (Unit 42): skin problem of horses caused by wet and dirty conditions.**

**rasp: to scrape or rub with a metal file.**

**ration (Unit 23): amount and composition of animal feed.**

**record: written information.**

**rectum: the last part of the gut which opens at the anus.**

**red worms: red parasitic worms of the gut and its blood vessels in equines.**

**reproductive system (Unit 3): the organs involved in reproduction and the production of young.**

**respiratory system: the lungs and windpipe, organs involved in breathing.**

**restrain (Unit 10): to control or prevent an animal from moving.**

**reticulum: one of the four stomachs of the ruminant also known as the honeycomb.**

**ribs: the bones of the chest.**

**rinderpest (Unit 25): infectious disease of cattle, cattle plague.**

**ringworm: infection causing round light coloured spots on the skin of animals and humans.**

**ruminant (Unit 7): animal which has a rumen and chews the cud.**

**ruminant (Unit 4): to chew the cud.**

**rumination: act of chewing the cud.**

**roughage: bulky feed which is only partly digestible.**

**roundworms: small worms, many of which are parasites.**

## **S**

**saddlery: the saddles and harnesses for horses.**

**saddle sores: painful areas of skin and wounds on the back caused by badly fitted saddles.**

**saliva: fluid produced in the mouth.**

**scalpel: a surgical instrument for cutting.**

**scaley: covered with scales.**

**scapula: the shoulder blade.**

**schistosomes (Unit 15): parasites found in the blood and urine.**

**screwworm: maggots of the screwworm fly which infect wounds forming deep holes; can cause death.**

**scrotum: the bag of skin containing the testicles.**

**semen: fluid produced by the testicles and other glands.**

**shear: to cut the wool off an animal.**

**shoeing: to fix metal to the bottom of the hoof to protect it.**

**silage: grass and plants cut green and stored in an airtight container for feed.**

**silent heat (Unit 17): animal in oestrus but signs of heat are not seen.**

**silo (Unit 23): airtight pit in which silage is made and stored.**

**skin scraping: scraping from an infected area of skin used to check for cause of problem.**

**skull: the bones of the head.**

**slaughterhouse: place where animals are killed for meat, abattoir.**

**sneeze: to expel air from the nose suddenly and with no control.**

**sodium bicarbonate: white substance used to treat bloat and neonatal diarrhoea, e.g. baking powder.**

**sole: the underside of the foot.**



**sorghum: grass grown for grain, hay and to make silage.**

**sow: female pig.**

**sperm: produced in the testicle and present in semen, fertilises the ova in the female.**

**spinal cord: main nerve supply running from the brain and protected in the backbone.**

**spleen: organ found near the stomach and involved in protecting the body from infection.**

**spongy: like a sponge, soft and with many holes or cavities.**

**sputum: saliva and mucous.**

**star gazing: sheep about to give birth holds head up and back as if watching the stars, a sign of the beginning of parturition in sheep.**

**stallion: a male horse (or equine).**

**sterilisation: killing all germs using heat or disinfectants.**

**straw: dried stems and leaves of grain plants.**

**strychnine: a very poisonous drug, used to kill stray dogs.**

**subcutaneous: under the skin.**

**subnormal: lower than normal.**

**suckle: to drink milk from the udder.**

**swill: boiled animal feed, especially for pigs.**

## **T**

**tack, tackle (Unit 47): the saddles, harness and bridles used with horses.**

**tapeworm: long, flat parasitic worm found in the gut.**

**teat: the opening in the udder through which the milk can pass.**

**teat catheter: instrument used to remove milk and fluid from the udder with mastitis.**

**teeth clipping (Unit 26): cutting off the sharp teeth of the young animal (pig) to prevent damage to the mother's teats during suckling.**

**temporary teeth: the first or milk teeth.**

**tether: rope used to tie up an animal.**

**testicles: the male reproductive organs found outside the scrotum.**

**thermometer: glass instrument used to measure temperature.**

**thrush (Unit 39): infection of the foot of equines.**

**tick: blood sucking external parasite.**

**tick-borne disease: disease spread by tick bites.**

**tourniquet: rope or cloth tied around a blood vessel to stop bleeding.**

**triplets (Unit 20): three young born from one birth.**

**trocar and cannula: instruments used to pierce the rumen and relieve bloat.**

**troughs: wooden or metal containers for feed or water.**

**tubercles: small hard lumps in the lungs and other organs of an animal infected with tuberculosis.**

**tuberculin: sterilised liquid produced from the germ which causes tuberculosis and used to test animals for tuberculosis.**

**tuberculosis (TB): infectious disease of the lungs and other organs which can be passed to humans from animals.**

**twins: two young born at the same time.**

**twitch: tool used on the muzzle to control equines.**

**tympany: bloat, excess gas in the rumen.**

## **U**

**udder: milk producing gland of the female.**

**urinary system (Unit 3): the kidneys and bladder which get rid of waste water and other substances as urine.**

**urine: fluid formed in the kidneys and containing waste substances and water.**

**uterus (Unit 3): the womb, the organ of the female in which the young develop.**

## **V**

**vaccination: putting a non-disease producing germ into the body to stimulate an animal's immunity.**

**vaccine: a fluid which can make the body develop protection (immunity) against a certain disease.**

**vagina: the part of the female into which the womb opens and through which urine passes to the outside of the body.**

**vegetation: plants, e.g. grasses, trees, shrubs.**

**veins: blood vessels which carry blood back to the heart.**

**ventilation: letting fresh air into an area or house.**

**vitamin: substance occurring naturally and essential to the normal working of the body.**

**vulva: where the vagina opens to the outside.**

## **W**

**wattles: fleshy areas around the beak and neck of chickens.**

**wallowing: to roll about in mud or water.**

**warfarin: poison which stops the blood from clotting.**

**water bag: the fluid filled bag in which the young develops and which comes out of the vulva at the beginning of birth.**

**wean: to stop drinking milk and eat solid food.**

**weaned: when the young animal no longer drinks milk.**

**whipworm: whip-like worm which is a parasite in the gut.**

**windpipe: tube which connects the lungs with the nostrils, the trachea.**

**womb: the uterus, the organ of the female in which the young develop.**

**wool: soft curly hair of sheep and other animals.**

**wound: a cut in the skin.**

**wrist: where the hand joins the arm.**

