

# Introduction to Control Design and Simulation using LabVIEW

**By:**  
Erik Luther



# Introduction to Control Design and Simulation using LabVIEW

**By:**

Erik Luther

**Online:**

< <http://cnx.org/content/col10401/1.1/> >

**C O N N E X I O N S**

Rice University, Houston, Texas

This selection and arrangement of content as a collection is copyrighted by Erik Luther. It is licensed under the Creative Commons Attribution 2.0 license (<http://creativecommons.org/licenses/by/2.0/>).

Collection structure revised: January 29, 2007

PDF generated: October 30, 2009

For copyright and attribution information for the modules contained in this collection, see p. 28.

# Table of Contents

<b>1 Control Design</b>	
<b>1.1 Model Construction</b> .....	1
<b>1.2 Model Interconnection</b> .....	5
<b>1.3 Model Conversion</b> .....	10
<b>1.4 Time Response</b> .....	12
<b>1.5 Frequency Response</b> .....	16
<b>1.6 Analyzing Dynamic Characteristics</b> .....	24
Solutions .....	??
<b>Attributions</b> .....	28



# Chapter 1

## Control Design

### 1.1 Model Construction<sup>1</sup>

#### 1.1.1 Model Construction Palette:

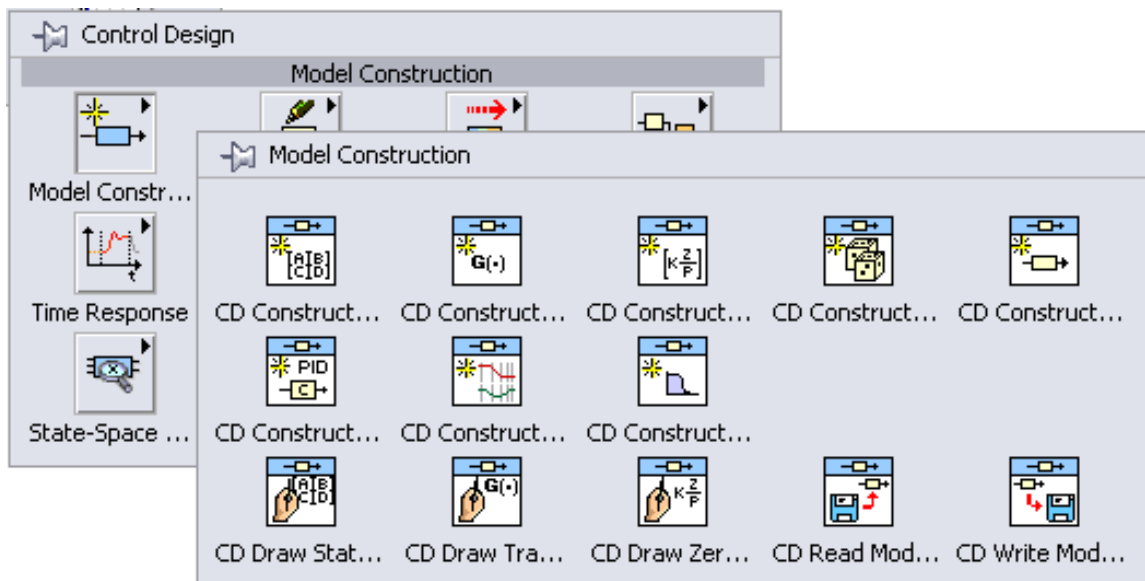

Figure 1.1

The VIs in this section are used to construct various types of Models like State Space, Transfer Function, and Zero-Pole-Gain.

The Construct State Space Model and Construct Transfer Function Model functions are discussed below.

<sup>1</sup>This content is available online at <http://cnx.org/content/m14285/1.1/>.

## 1.1.1.1 CD Construct State Space Model:

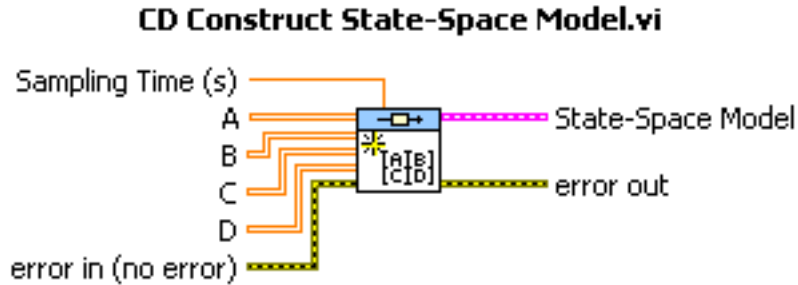

Figure 1.2

---

The terminals for the function are shown above. If the Sampling Time terminal is not connected, the system is by default considered continuous. Connecting a value to Sampling Time will change the system to discrete time using the given sampling time. There are terminals for the A, B, C, and D matrices of the State Space model. Once LabVIEW creates the State-Space model (available at the output terminal), it can be used for other functions and can be converted into other forms as is discussed further in this chapter.

Here is an example of creating a State Space model. The output can be connected as input to numerous other functions in the Control Design toolkit.



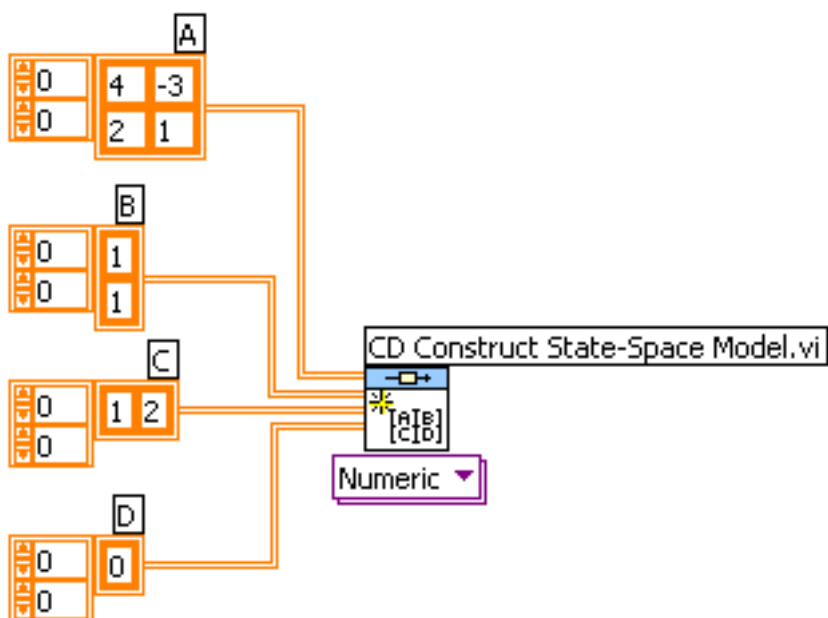

Figure 1.3

---

The inputs can be either constants (on the Block Diagram) or controls (on the Front Panel). Most examples shown will use constants on the Block Diagram to make this manual more readable, however oftentimes using controls on the Front Panel will be more efficient. The constants, controls, and indicators can all be created by right-clicking on the desired terminal and selecting an option from the pop-up menu.

The many special functions and data structures used in Control Design make this a very useful shortcut for creating the correct Controls and Indicators.

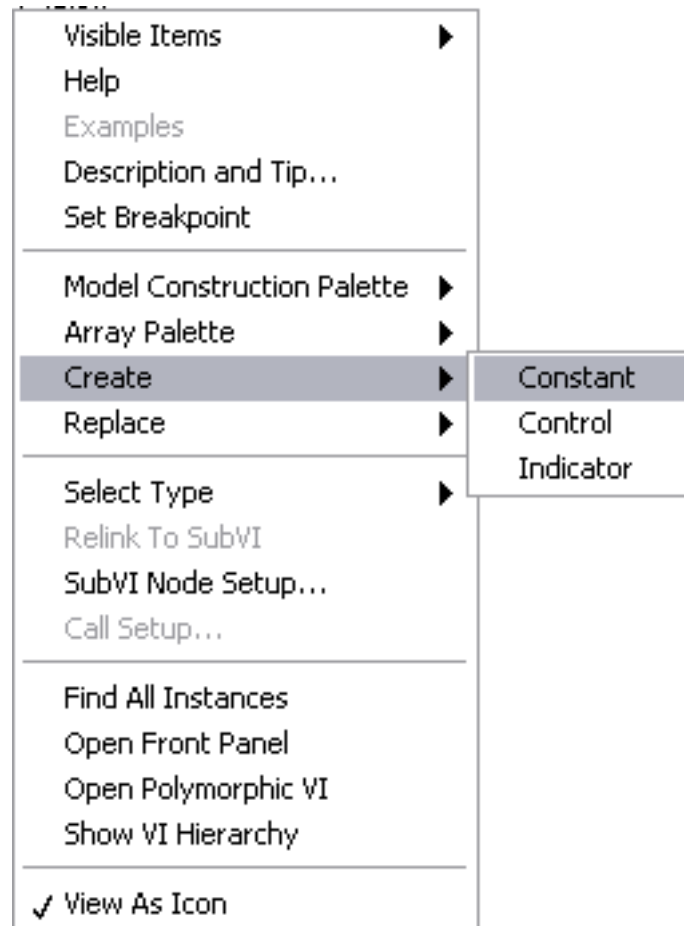

Figure 1.4

Many Control Design functions, including Construct State-Space Model, are polymorphic. A polymorphic VI will have the additional menu structure below the icon (in this figure above, labeled Numeric). This indicates that the input to the model is going to be in a numeric form.

Also available with the same function is the ability to enter the model in Symbolic form, meaning the input has variables in it, and the value of the variables is controlled from the Front Panel. To select this option, simply click on the bottom of the icon with the operating tool and select the Symbolic option.

NOTE: The symbolic option is discussed in further detail later.

### 1.1.1.2 CD Construct Transfer Function Model:

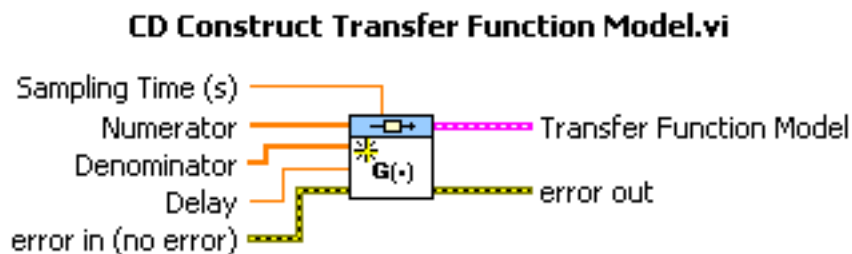

Figure 1.5

The terminals are shown above. The important terminals are the Numerator and Denominator. As in the previous case, once the model is created, it can either be displayed on the Front Panel or connected to other functions. There is also a Symbolic input option in this case, and examples of it are available in further chapters.

#### Example 1.1

Transfer Function and associated inputs for the numerator and denominator are shown below. Notice the order of the coefficients.

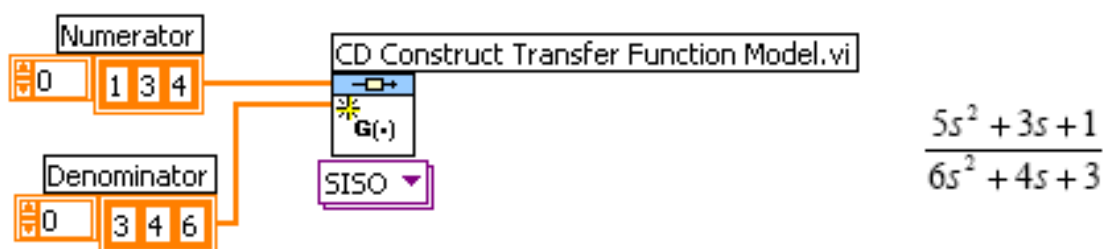

Figure 1.6

In LabVIEW, the first element of the array is the coefficient of  $s^0$ , the second element is coefficient of  $s^1$ , the third is coefficient of  $s^2$ , and so on.

NOTE: Only the State Space and Transfer function representation have been represented in the tutorial. Many other model types exist.

## 1.2 Model Interconnection<sup>2</sup>

### 1.2.1 Model Interconnection Palette:

The VIs in this sub-palette can be used to connect different models in various configurations (i.e. Series, Parallel or Feedback mode).

<sup>2</sup>This content is available online at <http://cnx.org/content/m14284/1.1/>.

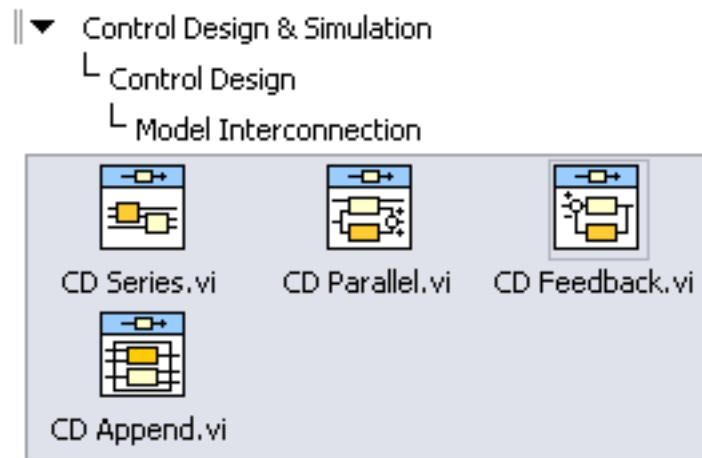

Figure 1.7

---

The State Space and Transfer Function Model created previously are now connected in Series.

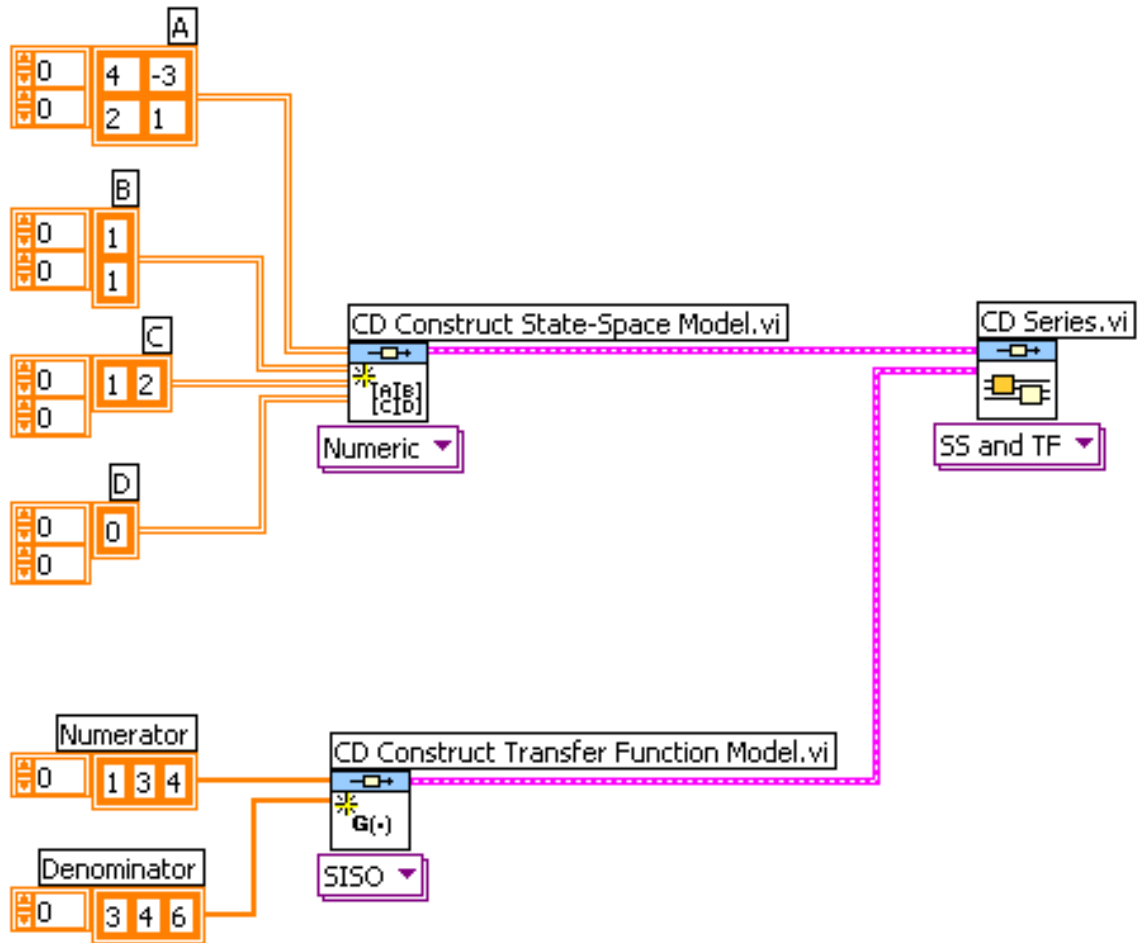
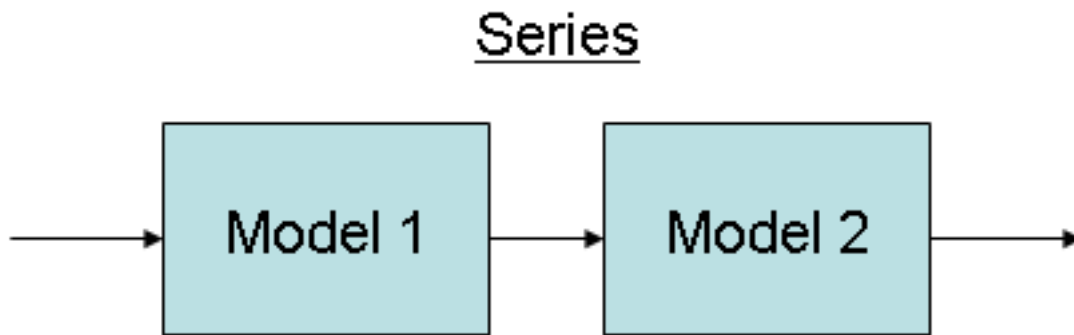

Figure 1.8

The above LabVIEW diagram creates the following system in block representation. Above, Model 1 is the state space model and Model 2 is the transfer function model.



**Figure 1.9**

---

This example also indicates the polymorphic nature of the functions. Note that the Polymorphic VI Selector at the bottom of the CD Series VI has changed to indicate SS and TF meaning that one of the inputs is a State Space Model and the other is a Transfer Function Model. LabVIEW performs this change automatically.

In the same manner, if you want to connect the Transfer Function Model in the feedback path of the State Space model, the function CD Feedback would be used.

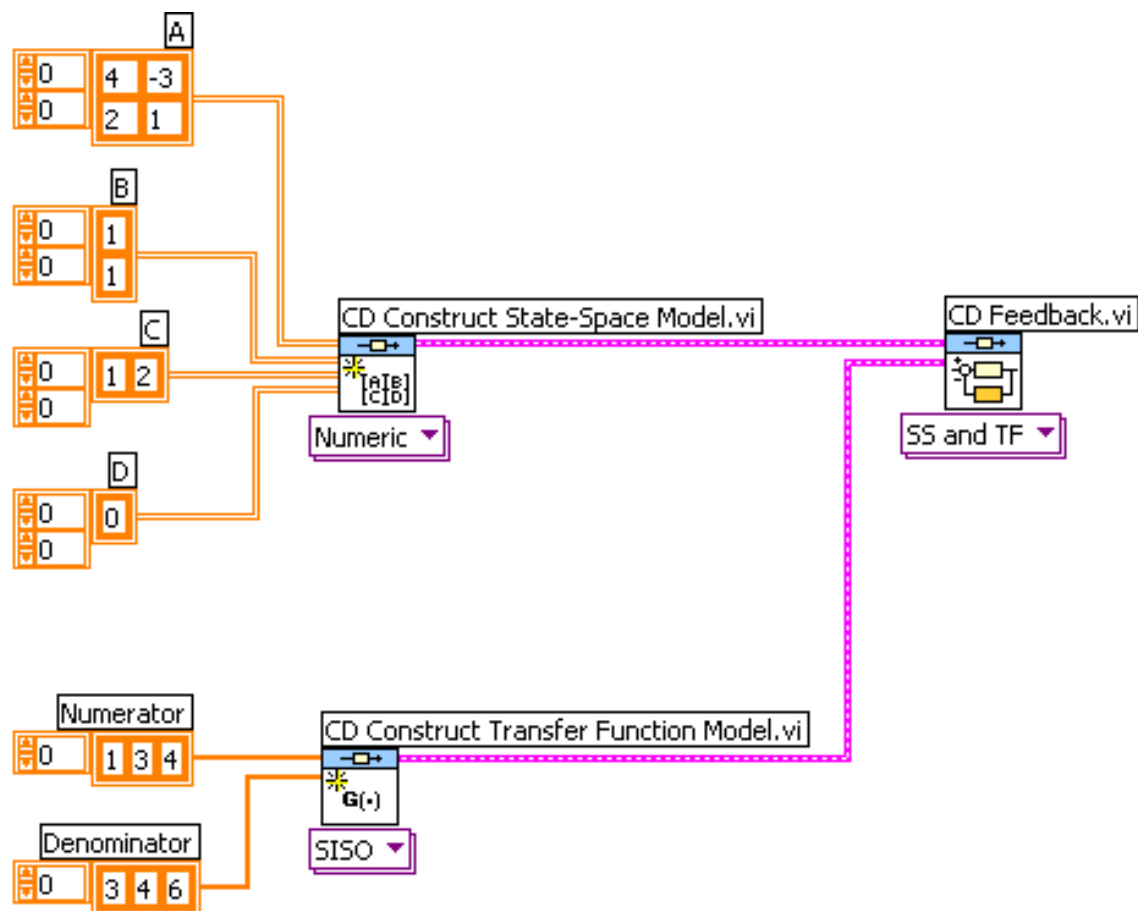

Figure 1.10

---

The above LabVIEW diagram creates the following system in block representation. Above, Model 1 is the state space model and Model 2 is the transfer function model.

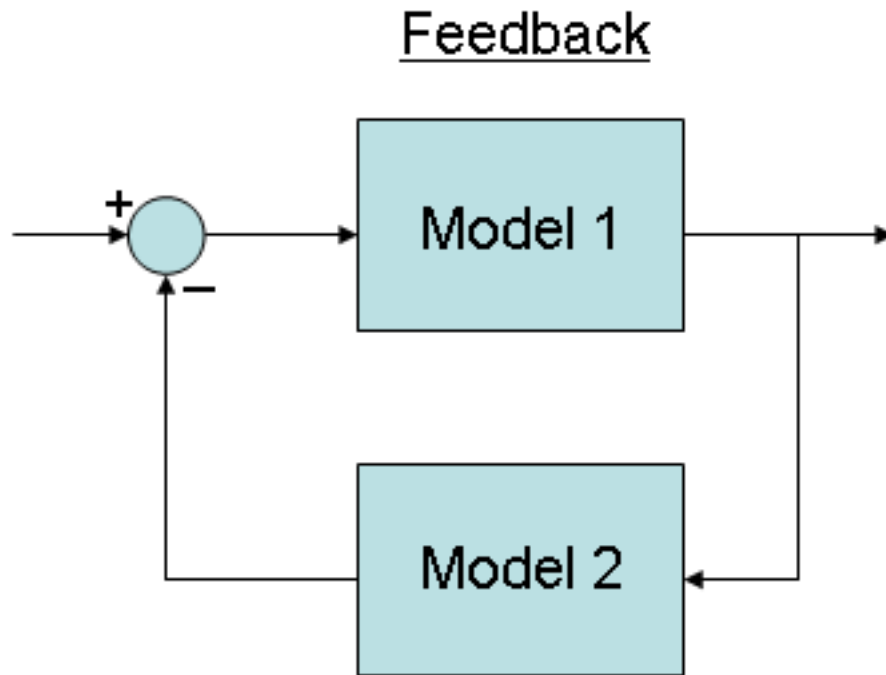

Figure 1.11

---

NOTE: In this case, the order in which the models are connected is important. The model that is in the feedback path is connected to the second terminal (Model 2).

Thus, if we had to connect the State Space model in the feedback path of the Transfer Function Model, the input connections would need to be reversed.

## 1.3 Model Conversion<sup>3</sup>

### 1.3.1 Model Conversion Palette:

The VIs found in the Model Conversion sub-palette are used to convert system models from one representation to another (i.e. from State Space representation to Transfer Function or Pole-Zero-Gain and vice versa). Continuous model and discrete time models can also be converted from and into one another.

<sup>3</sup>This content is available online at <http://cnx.org/content/m14287/1.1/>.



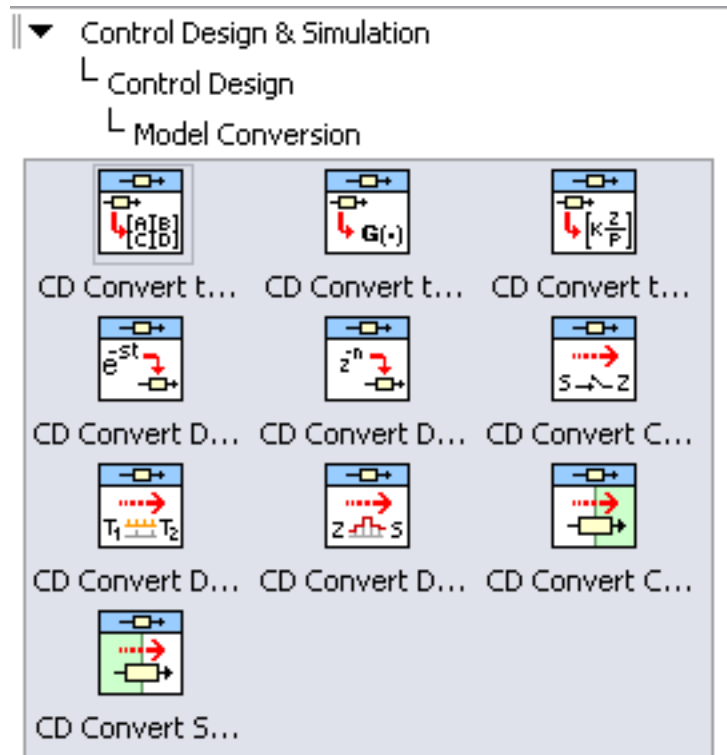

Figure 1.12

To convert the State space model discussed previously into a Transfer Function Model, use a similar Block Diagram to the one shown below.

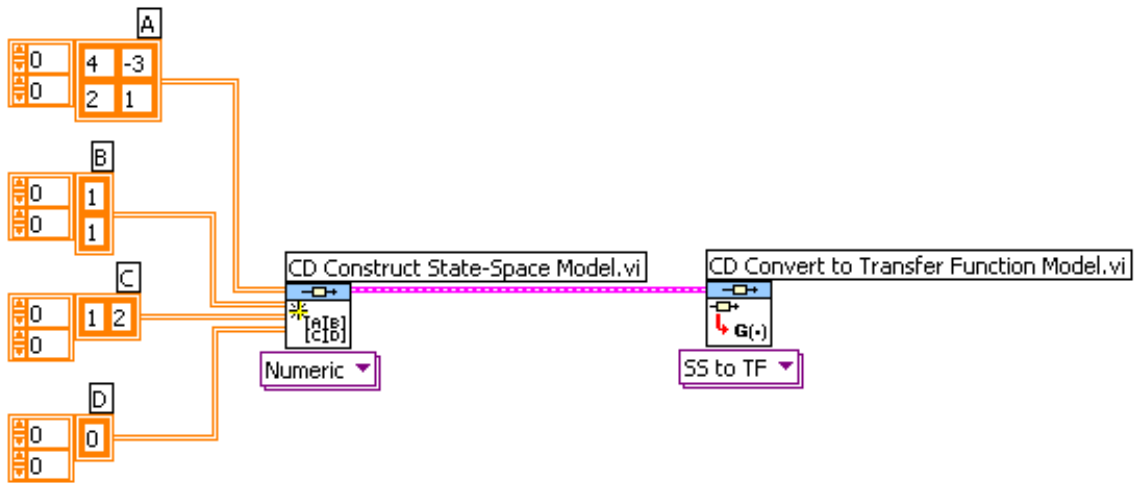

Figure 1.13

Alternatively, if you wish to convert the Transfer Function Model into a State Space Model, the following connection should be made.

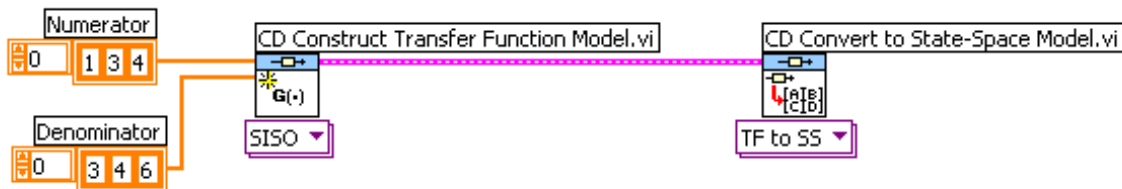

Figure 1.14

Other functions in this sub-palette can be connected in a similar fashion.

## 1.4 Time Response<sup>4</sup>

### 1.4.1 Time Response Palette:

The VIs from this palette that are used most often include CD Step Response and CD Impulse Response. Again, these are polymorphic functions.

<sup>4</sup>This content is available online at <http://cnx.org/content/m14283/1.1/>.

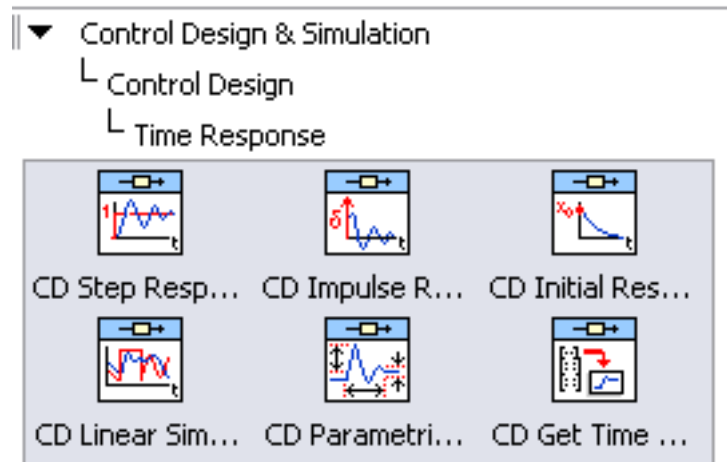

Figure 1.15

The following Block Diagram shows the Step and Impulse Response of the Transfer Function model. The output graphs are obtained by creating indicators from the output terminals of the Step and Impulse Response functions.

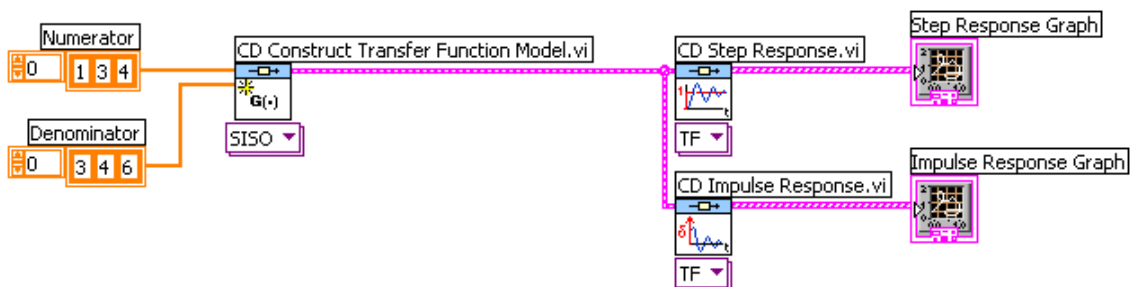

Figure 1.16

The output graphs as shown on the Front Panel:

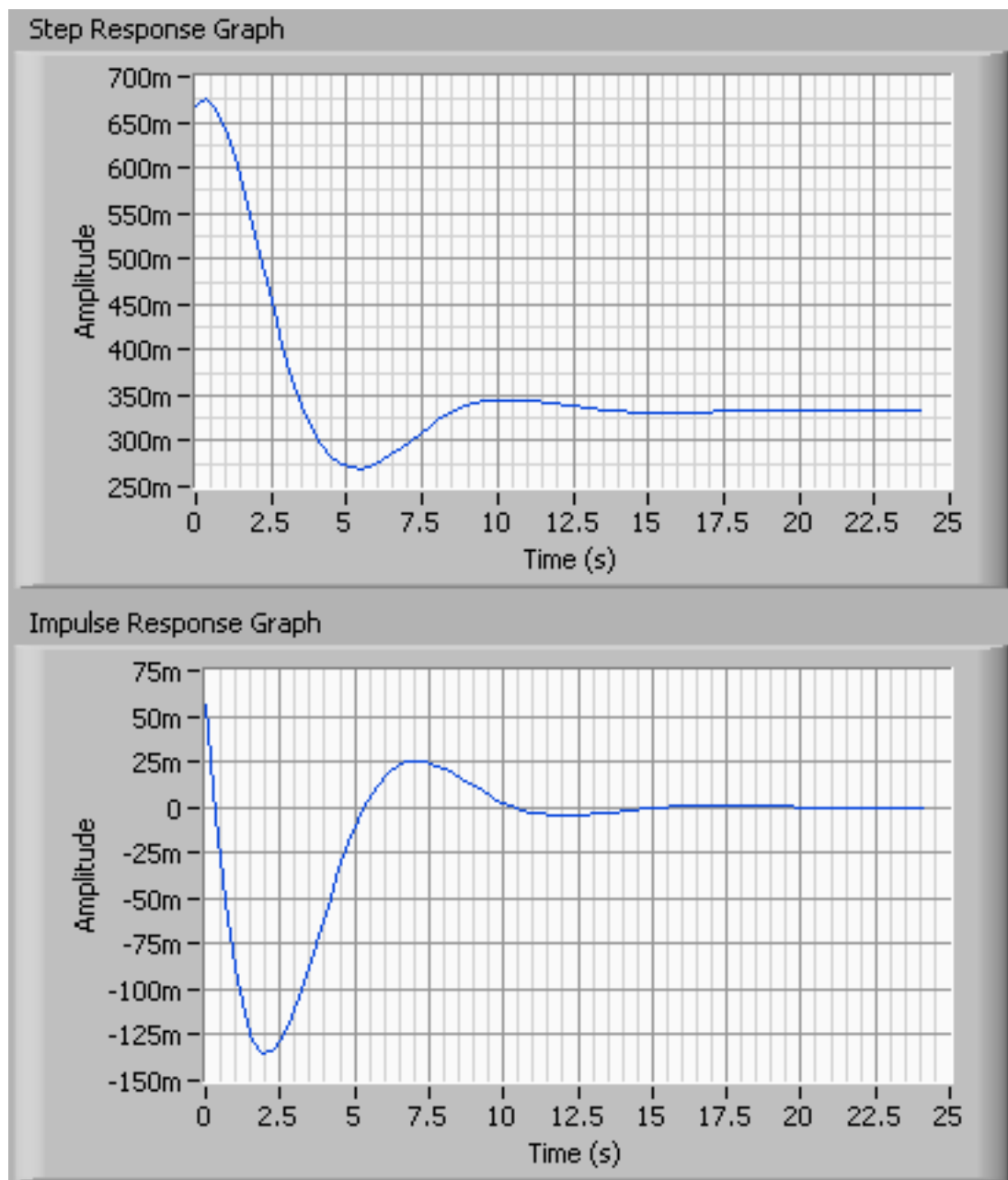

Figure 1.17

Additionally, statistics on the performance of the step response can be calculated. The implementation and results of the CD Parametric Time Response VI can be seen in the following two figures.

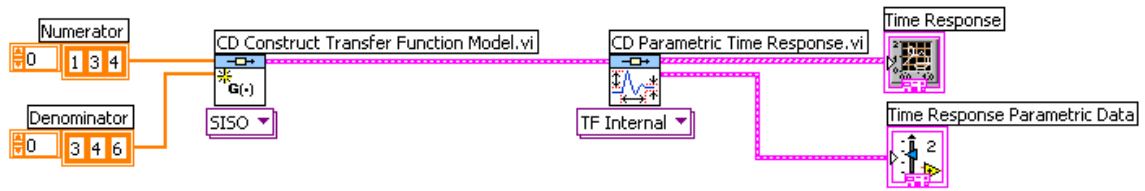

Figure 1.18

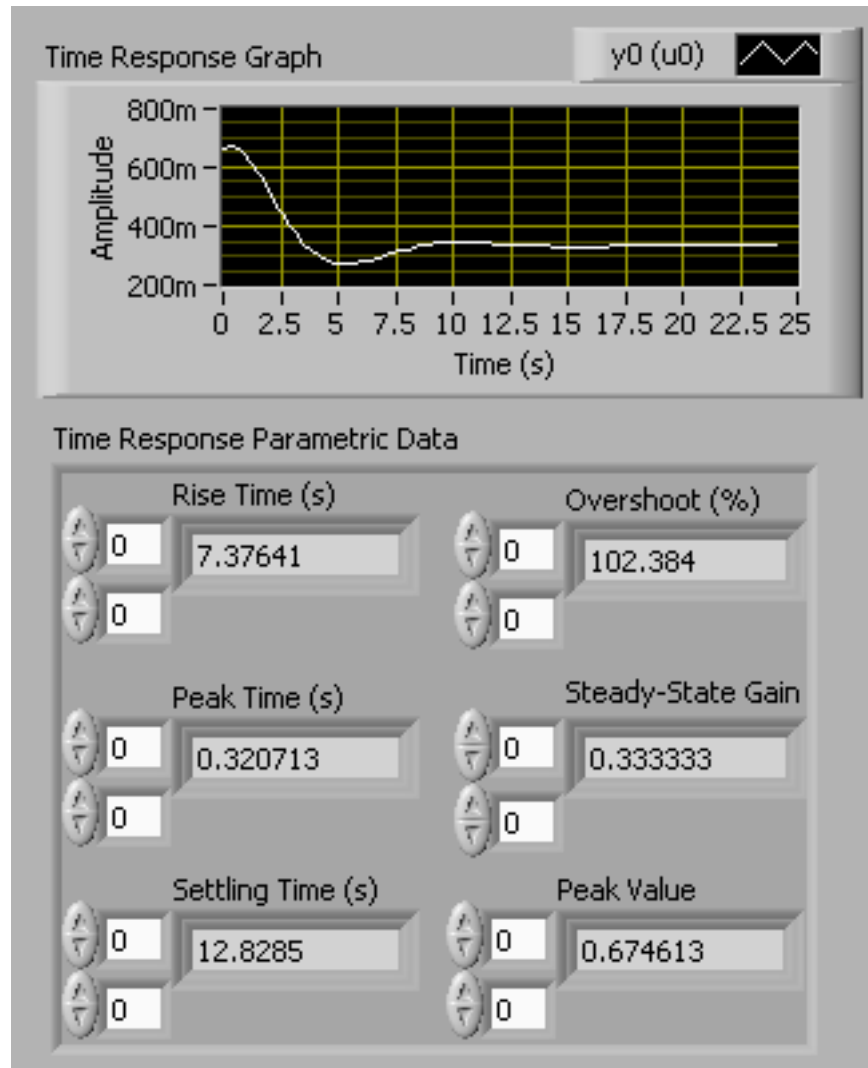

Figure 1.19

When this VI is used for State Space model or system analysis, the results for each individual state is given.

## 1.5 Frequency Response<sup>5</sup>

### 1.5.1 Frequency Response Palette:

The VIs in this sub-palette that are used most frequently are CD Bode, CD Nyquist, and CD Gain and Phase Margins. These VIs are frequently used in Chapter 6, and are also polymorphic.

<sup>5</sup>This content is available online at <<http://cnx.org/content/m14288/1.1/>>.

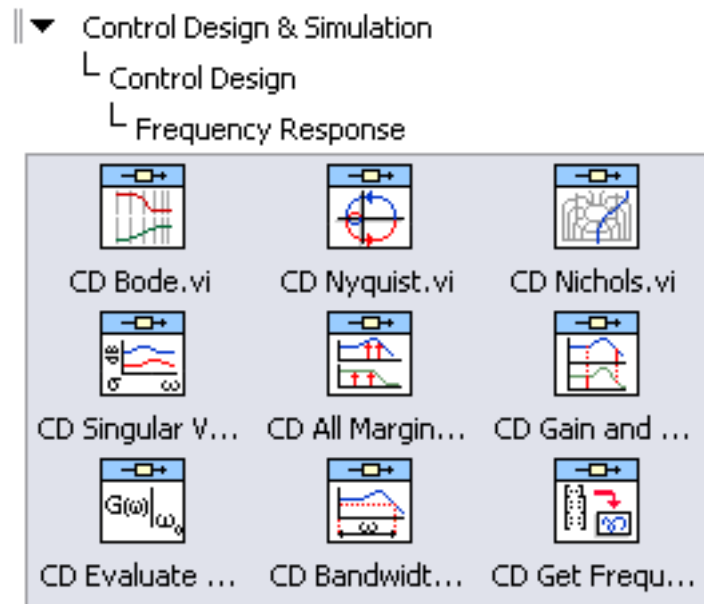

Figure 1.20

## 1.5.1.1 CD Bode.vi:

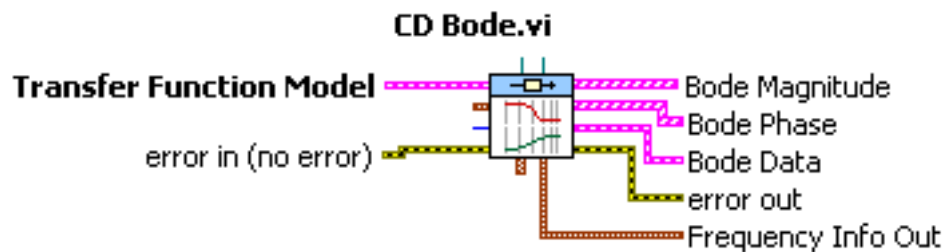

Figure 1.21

This VI gives the Bode Magnitude and Phase plots of a system, and the input is the open loop model.

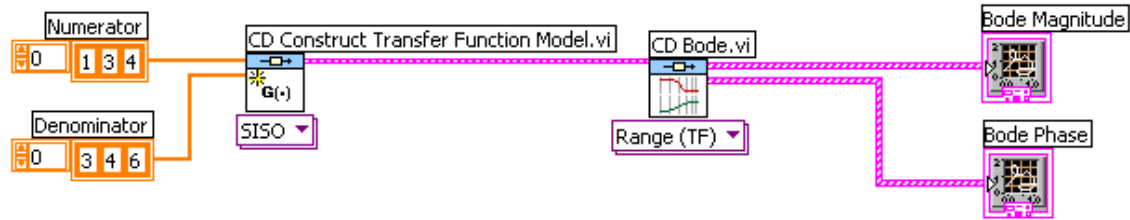

Figure 1.22

The output terminals that are of interest are the ones for plotting the Magnitude and Phase graphs. These can be plotted by creating indicators for the respective terminals. The magnitude plot is shown here.



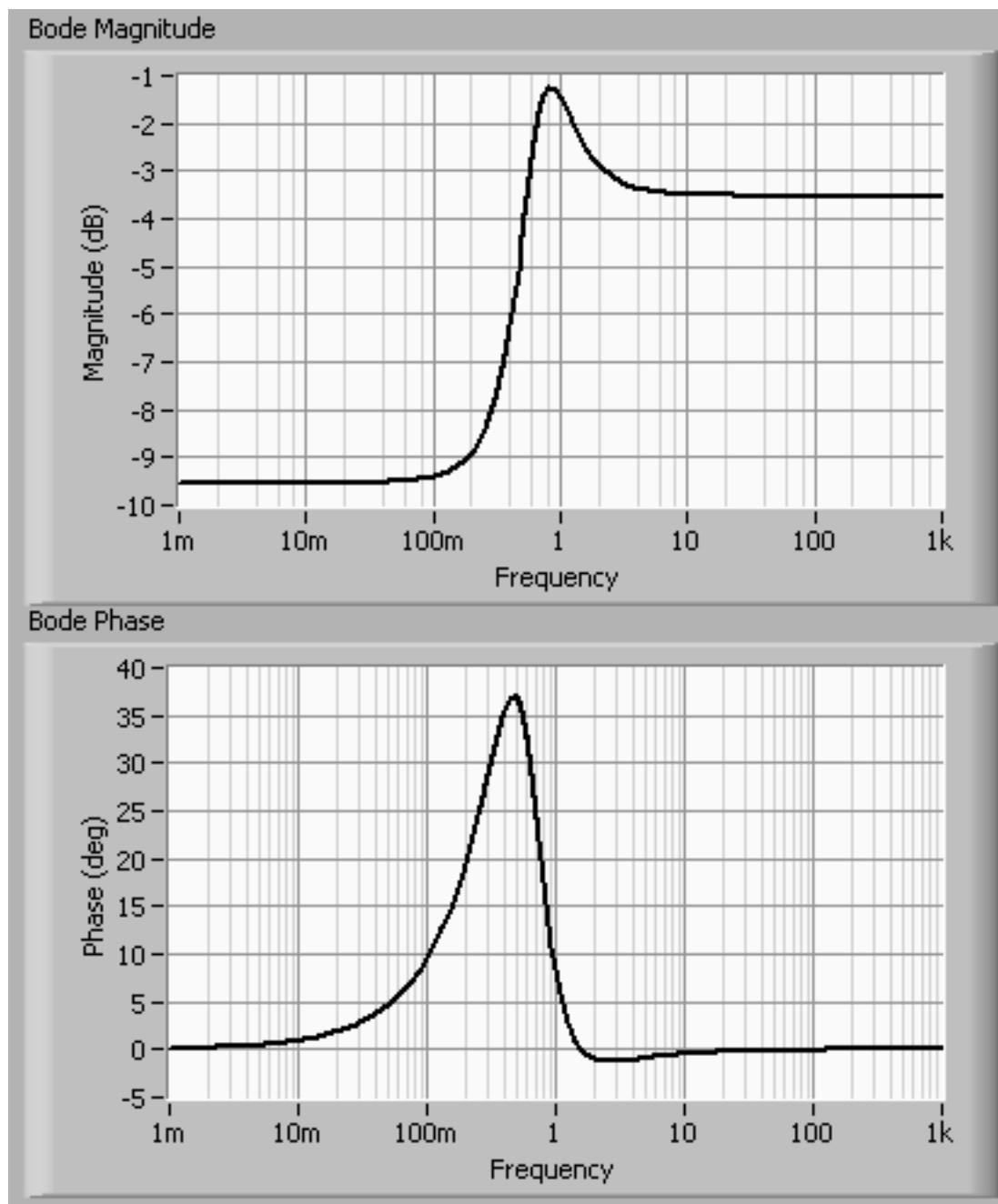

Figure 1.23

## 1.5.1.2 CD Nyquist.vi:

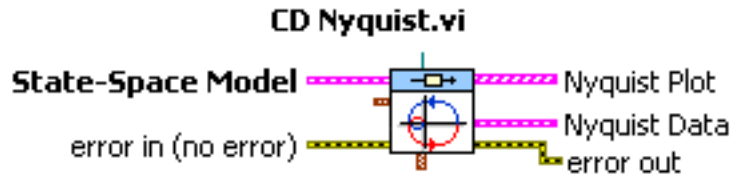

Figure 1.24

This VI gives the Nyquist plot of a system.

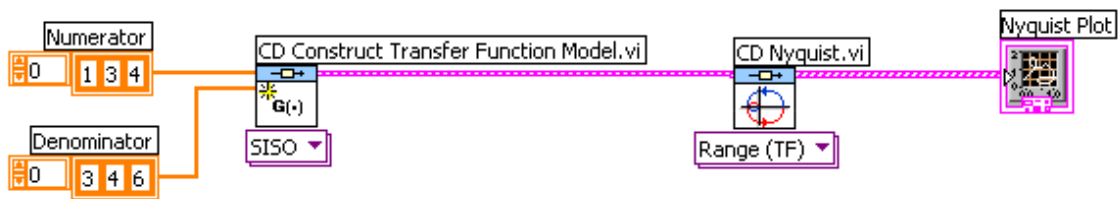

Figure 1.25

Remember to right-click on the output terminal of CD Nyquist and select Create»Indicator to create the Nyquist Plot indicator.

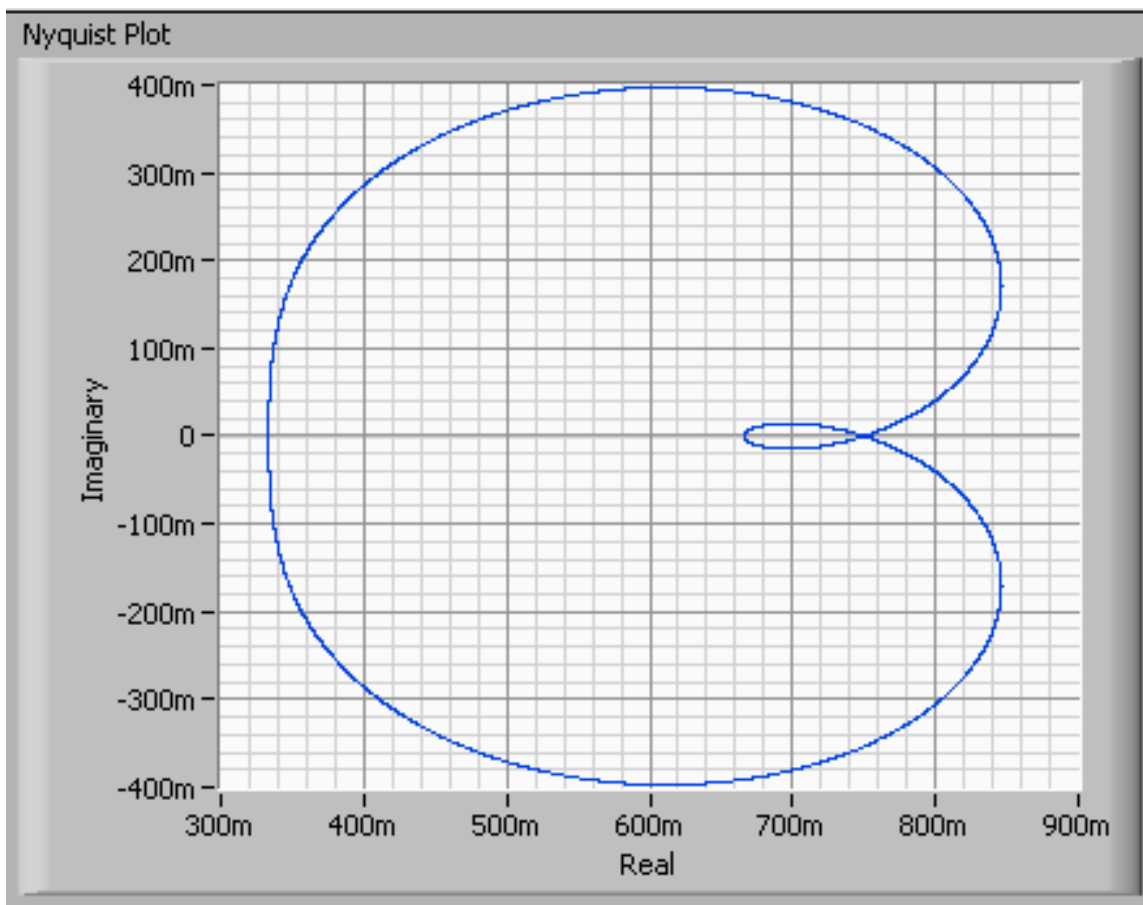

Figure 1.26

### 1.5.1.3 CD Gain and Phase Margin.vi:

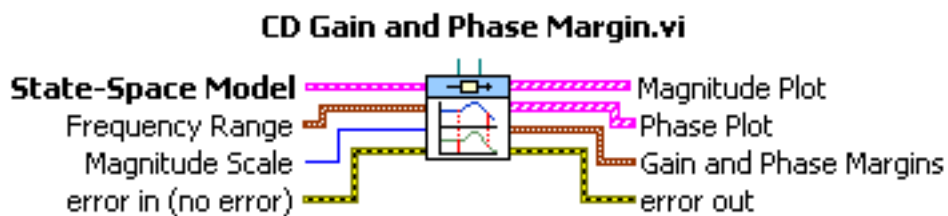

Figure 1.27

This VI gives the Gain and Phase Margins of a system, along with the Magnitude and Phase graph indicating the position where the Gain and Phase Margins occur.

NOTE: The numerator has been changed so that the function has a valid Phase Margin.

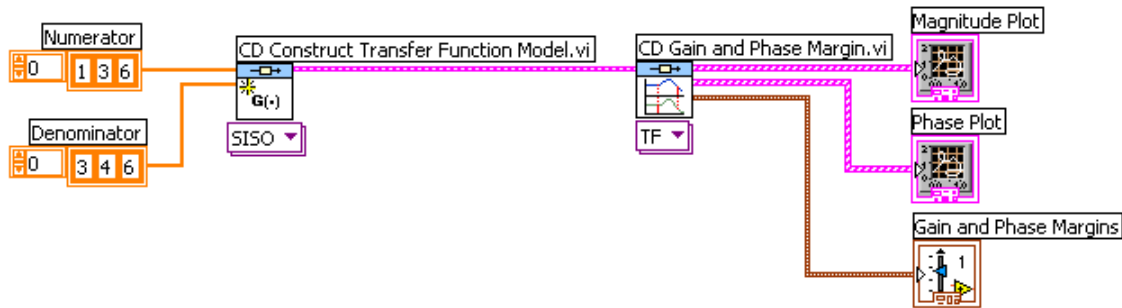

Figure 1.28

The Gain and Phase margins are shown in a numeric indicator as shown.

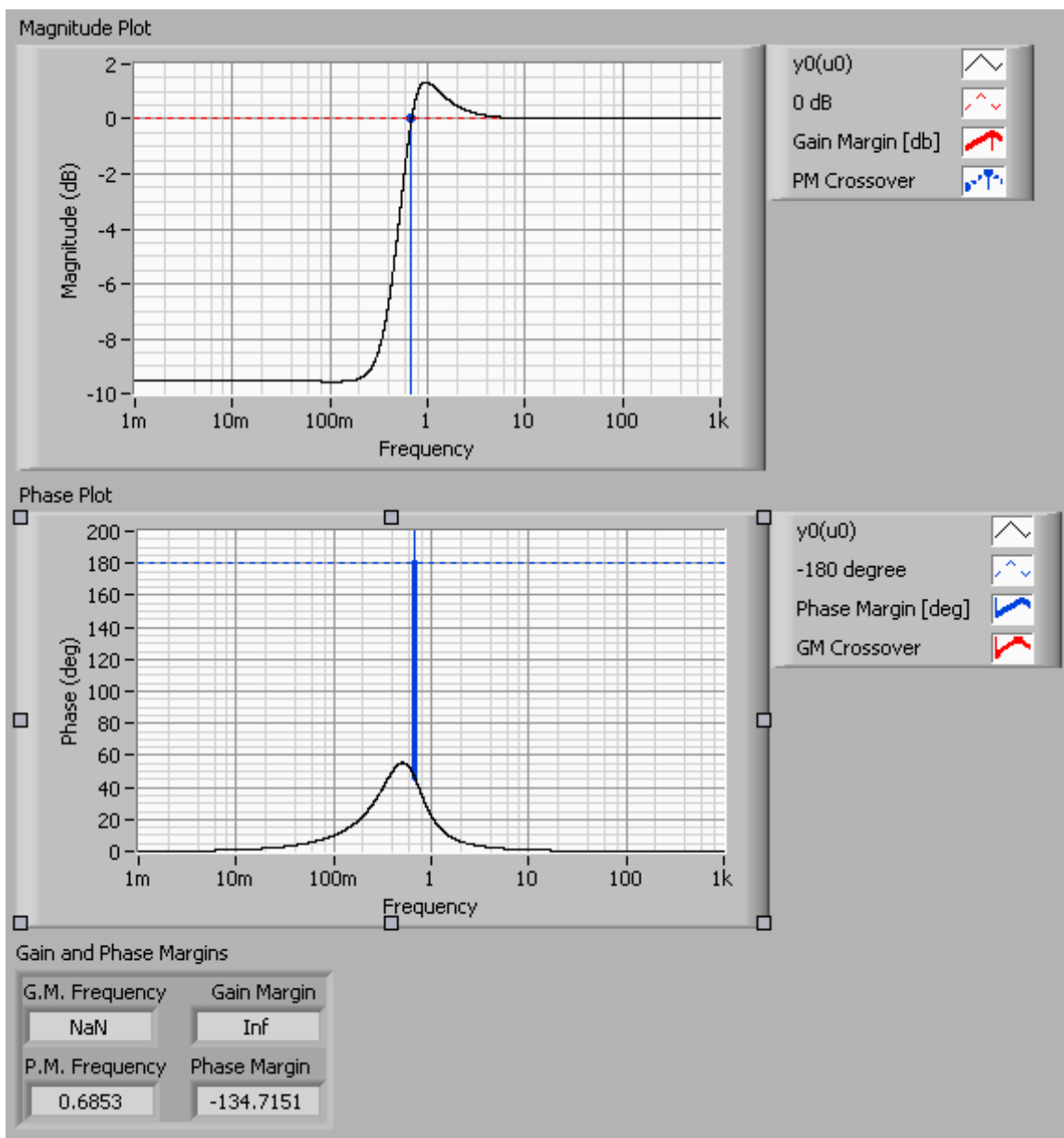

Figure 1.29

The Magnitude graph obtained from the Block Diagram above is shown below. The zero crossing of the magnitude is indicated in the plot.

## 1.6 Analyzing Dynamic Characteristics<sup>6</sup>

### 1.6.1 Dynamic Characteristics Palette:

The VIs found here are used to find the dynamic properties of a system (i.e. Root Locus, DC Gain, Time Response Parametric Data, etc).

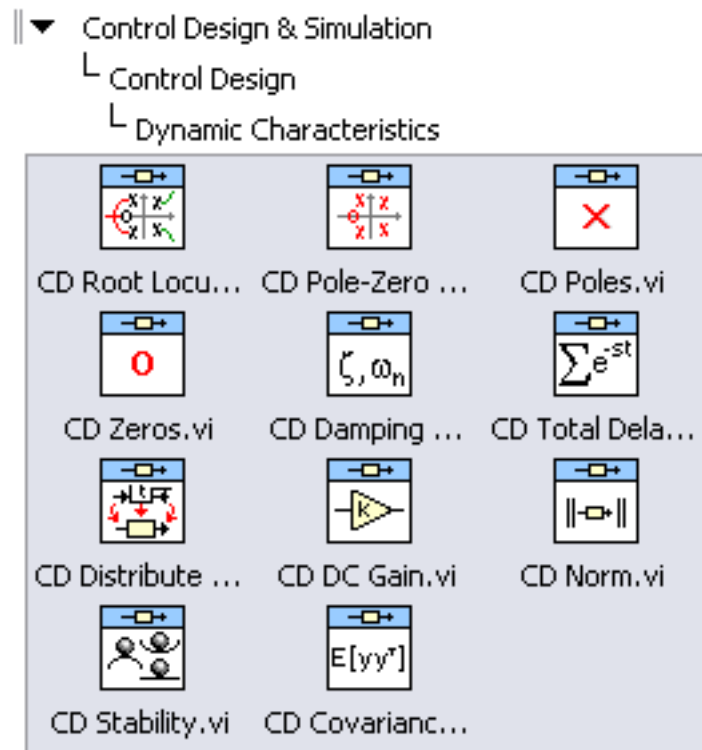

Figure 1.30

The most frequently used VI of this sub-palette is CD Root Locus. This VI plots the trajectory of closed loop poles as the feedback gain varies from zero to infinity.

<sup>6</sup>This content is available online at <<http://cnx.org/content/m14282/1.1/>>.

## 1.6.1.1 CD Root Locus.vi:

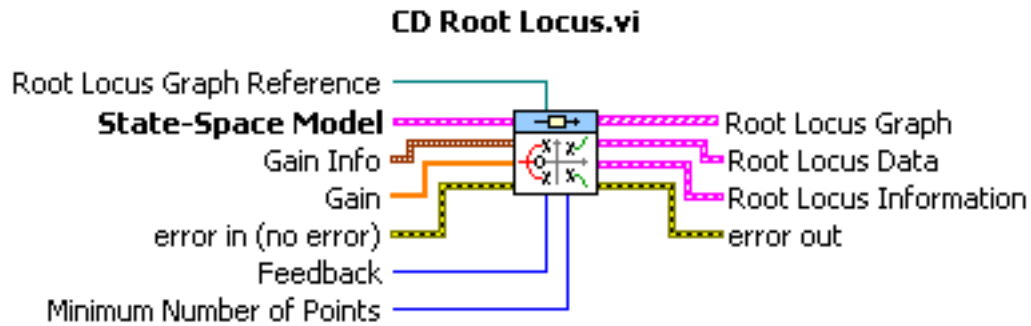

Figure 1.31

This function gives the Root Locus plot of a system. This polymorphic VI accepts any model as an input, including Transfer Function, State-Space or Pole-Zero-Gain models. The indicator for this VI is created in the same fashion as that for CD Nyquist, and the grid type can only be changed from the Block Diagram.

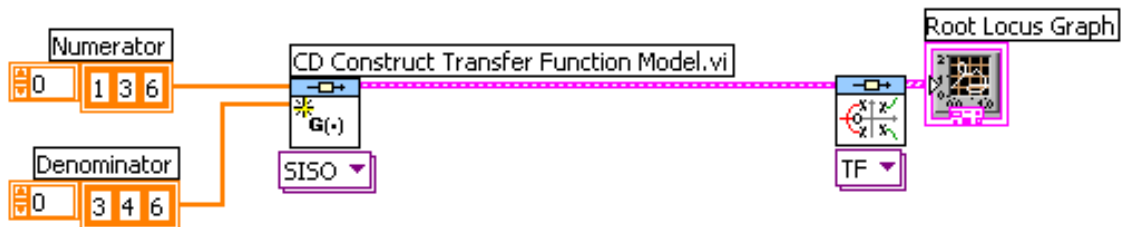

Figure 1.32

The Root Locus plot in the Front Panel is shown here. This function also plots the Evans plot or trajectory of closed-loop poles.

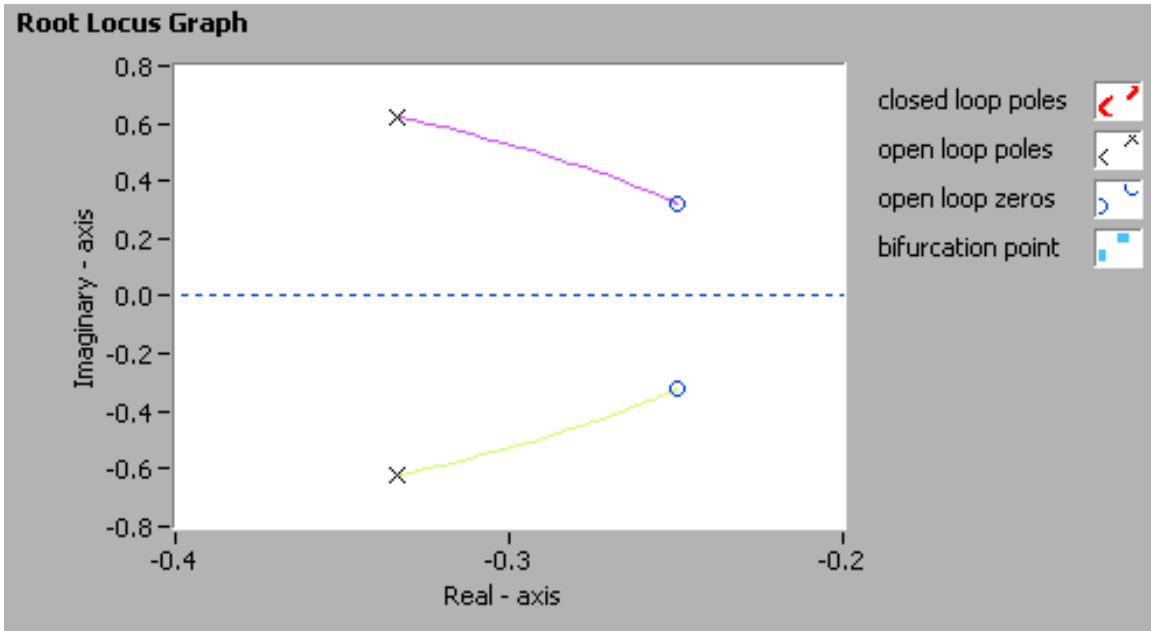

Figure 1.33

1.6.1.2 DC Gain.vi:

This VI calculates the DC Gain of the system.

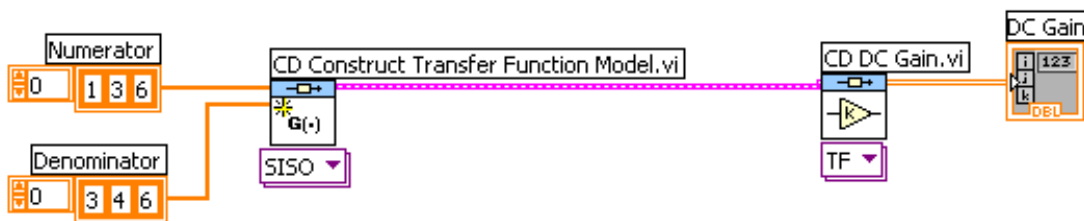

Figure 1.34

The DC Gain of the system is shown in the Front Panel.



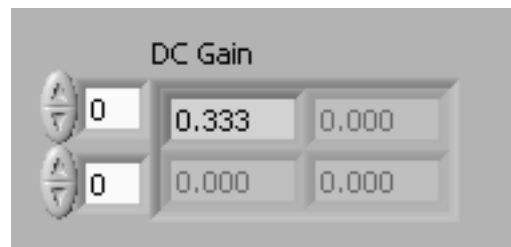

Figure 1.35

---

## Attributions

Collection: *Introduction to Control Design and Simulation using LabVIEW*

Edited by: Erik Luther

URL: <http://cnx.org/content/col10401/1.1/>

License: <http://creativecommons.org/licenses/by/2.0/>

Module: "Model Construction"

By: Erik Luther

URL: <http://cnx.org/content/m14285/1.1/>

Pages: 1-5

Copyright: Erik Luther

License: <http://creativecommons.org/licenses/by/2.0/>

Module: "Model Interconnection"

By: Erik Luther

URL: <http://cnx.org/content/m14284/1.1/>

Pages: 5-10

Copyright: Erik Luther

License: <http://creativecommons.org/licenses/by/2.0/>

Module: "Model Conversion"

By: Erik Luther

URL: <http://cnx.org/content/m14287/1.1/>

Pages: 10-12

Copyright: Erik Luther

License: <http://creativecommons.org/licenses/by/2.0/>

Module: "Time Response"

By: Erik Luther

URL: <http://cnx.org/content/m14283/1.1/>

Pages: 12-16

Copyright: Erik Luther

License: <http://creativecommons.org/licenses/by/2.0/>

Module: "Frequency Response"

By: Erik Luther

URL: <http://cnx.org/content/m14288/1.1/>

Pages: 16-23

Copyright: Erik Luther

License: <http://creativecommons.org/licenses/by/2.0/>

Module: "Analyzing Dynamic Characteristics"

By: Erik Luther

URL: <http://cnx.org/content/m14282/1.1/>

Pages: 24-27

Copyright: Erik Luther

License: <http://creativecommons.org/licenses/by/2.0/>

## **Introduction to Control Design and Simulation using LabVIEW**

This course provides a brief introduction to the Control Design Toolkit and Simulation Module within LabVIEW. It introduces basic usage and configuration of the tools.

## **About Connexions**

Since 1999, Connexions has been pioneering a global system where anyone can create course materials and make them fully accessible and easily reusable free of charge. We are a Web-based authoring, teaching and learning environment open to anyone interested in education, including students, teachers, professors and lifelong learners. We connect ideas and facilitate educational communities.

Connexions's modular, interactive courses are in use worldwide by universities, community colleges, K-12 schools, distance learners, and lifelong learners. Connexions materials are in many languages, including English, Spanish, Chinese, Japanese, Italian, Vietnamese, French, Portuguese, and Thai. Connexions is part of an exciting new information distribution system that allows for **Print on Demand Books**. Connexions has partnered with innovative on-demand publisher QOOP to accelerate the delivery of printed course materials and textbooks into classrooms worldwide at lower prices than traditional academic publishers.