

6400 Line Matrix Printers



Operator's Guide

Cabinet and Pedestal Models



Form Number S246-0115-02
©Copyright IBM Corp., 1995, 1996, 1997

L

└



S246-0115-02



6400 Line Matrix Printer

Operator's Guide

Cabinet and Pedestal Models



Note!

Before using the information and the product it works with, ensure that you read the general information under "Notices" on page iv.

Third Edition (January, 1997)

The following paragraph does not apply to any other country where such provisions are inconsistent with local law.

INTERNATIONAL BUSINESS MACHINES CORPORATION PROVIDES THIS PUBLICATION "AS IS" WITHOUT WARRANTY OF ANY KIND, EITHER EXPRESS OR IMPLIED, INCLUDING, BUT NOT LIMITED TO THE IMPLIED WARRANTIES OF MERCHANTABILITY OR FITNESS FOR A PARTICULAR PURPOSE. Some states do not allow disclaimer of express or implied warranties in certain transactions, therefore, this statement may not apply to you. Requests for IBM publications should be made to your IBM representative, or to the IBM branch serving your locality. Publications are not stocked at the address given below.

A Reader's Comments form is provided at the back of this publication. You may send your comments by facsimile to 1-800-524-1519, by E-mail to print_pubs@vnet.ibm.com, or by mail to:

IBM PRINTING SYSTEMS COMPANY
DEPARTMENT H7FE BUILDING 003G
INFORMATION DEVELOPMENT
PO BOX 1900
BOULDER, CO
80301-9191
USA

When you send information to IBM, you grant a nonexclusive right to use or distribute the information in any way IBM believes appropriate without incurring any obligation to you.

© **Copyright International Business Machines Corporation 1995, 1996, 1997.**

All rights reserved.

Note to U.S. Government Users – Documentation related to restricted rights – Use, duplication or disclosure is subject to restrictions set forth in GSA ADP Schedule Contract with IBM Corp.

About this Operator's Guide

This guide describes basic operating procedures for the IBM 6400 printer. This guide has been designed to meet the needs of all users, from beginners to those experienced with these printers.

The *Operator's Guide* is divided into three sections:

Basic Operating Procedures — gives an overview of the operator panel and provides procedures for loading paper and ribbon.

Configurations — provides procedures for using the operator panel to change formatting features.

Troubleshooting — gives instructions for clearing paper jams, cleaning the printer, and understanding fault messages.

Cabinet Models

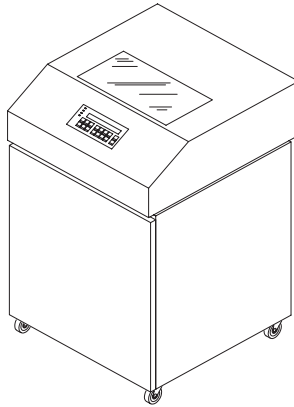

Pedestal Models

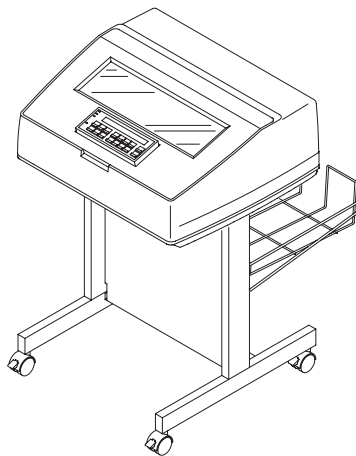



about this operator's guide

Conventions

Notes and Notices

In order to avoid injury to yourself or damage to the printer, follow the directions in this guide, paying attention to all dangers, cautions, and warnings

Danger, Caution, and Warning notices are numbered. These numbers enable you to find translated versions of these notices in the *IBM 6400 Line Matrix Printer Safety Notices* booklet.

A **Danger** notice calls attention to a situation that is potentially lethal or extremely hazardous to people.

danger

A **Caution** notice calls attention to a situation that is extremely hazardous to people because of some existing condition.

caution

A **Warning** notice indicates the possibility of damage to a program, device, system, or data.

warning

Important draws your attention to information vital to proper operation of the printer.

important

A **Note** gives you helpful tips about printer operation.

note

Message Display

These boxes show display messages as they appear on the operator panel.

READY





Table of Contents

BASIC OPERATING PROCEDURES

Powering On the Printer	2
Using the Operator Panel	4
Changing the Paper Exit Location (Pedestal Models Only)	19
Loading Paper	22
Reloading Paper	29
Unloading Paper	37
Setting Top-of-Form	39
Replacing the Ribbon	42
Canceling a Print Job	45

CONFIGURATIONS

Parameters and Configurations	49
Saving Configurations	51
Recalling Configurations	53
Deleting Configurations	55
The Power-On Configuration	57
Protecting Custom Sets	59
Printing Configurations	61
Operator Print Tests	63

TROUBLESHOOTING

Clearing Paper Jams	67
Cleaning the Printer	70
Solving Printer Problems	74
Fault Messages	76



Notices

References in this publication to IBM products, programs, or services do not imply that IBM intends to make these available in all countries in which IBM operates. Any reference to an IBM licensed product, program, or service is not intended to state or imply that only IBM's product, program, or service may be used. Any functionally equivalent product, program, or service that does not infringe any of IBM's intellectual property rights may be used instead of the IBM product. Evaluation and verification of operation in conjunction with other products, except those expressly designated by IBM, is the user's responsibility.

Any performance data contained in this document was obtained in a controlled environment based on the use of specific data. The results that may be obtained in other operating environments may vary significantly. Users of this document should verify the applicable data in their specific environment. Therefore, such data does not constitute a performance guarantee or warranty.

IBM may have patents or pending patent applications covering subject matter in this document. The furnishing of this document does not give you any license to these patents. You can send license inquiries, in writing, to the IBM Corporation, IBM Director of Licensing, 208 Harbor Drive, Stamford, Connecticut, United States, 06904.



Communication Notices

Federal Communications Commission (FCC) Statement: This equipment has been tested and found to comply with the limits for a Class A digital device, pursuant to Part 15 of the FCC Rules. These limits are designed to provide reasonable protection against harmful interference when the equipment is operated in a commercial environment. This equipment generates, uses, and can radiate radio frequency energy and, if not installed and used in accordance with the instruction manual, may cause harmful interference to radio communications. Operation of this equipment in a residential area is likely to cause harmful interference, in which case the user will be required to correct the interference at his own expense.

Properly shielded and grounded cables and connectors must be used in order to meet FCC emission limits. IBM is not responsible for any radio or television interference caused by using other than recommended cables and connectors or by unauthorized changes or modifications to this equipment. Unauthorized changes or modifications could void the user's authority to operate the equipment.

This device complies with Part 15 of the FCC Rules. Operation is subject to the following two conditions: (1) this device may not cause harmful interference, and (2) this device must accept any interference received, including interference that may cause undesired operation.

Canadian Department of Communications Compliance Statement: This Class A digital apparatus meets the requirements of the Canadian Interference-Causing Equipment Regulations.

Avis de conformité aux normes du ministère des Communications du Canada: Cet appareil numérique de la classe A respecte toutes les exigences du Règlement sur le matériel brouilleur du Canada.

The United Kingdom Telecommunications Statement of Compliance: This apparatus is approved under the approval No. NS/G/1234/J/100003 for the indirect connections to the public telecommunications systems in the United Kingdom.



Japanese VCCI:

この装置は、第一種情報装置（商工業地域において使用されるべき情報装置）で商工業地域での電波障害防止を目的とした情報処理装置等電波障害自主規制協議会（VCCI）基準に適合しております。

従って、住宅地域またはその隣接した地域で使用すると、ラジオ、テレビジョン受信機等に受信障害を与えることがあります。

取扱説明書に従って正しい取り扱いをして下さい。

1028

European Union (EC) Electromagnetic Compatibility Directives: This product is in conformity with the protection requirements of EC Council Directive 89/336/EEC on the approximation of the laws of the Member States relating to electromagnetic compatibility. IBM cannot accept responsibility for any failure to satisfy the protection requirements resulting from a non-recommended modification of the product, including the fitting of non-IBM option cards.

Dieses Gerät ist berechtigt in Übereinstimmung mit dem deutschen EMVG vom 9.Nov.92 das EG-Konformitätszeichen zu führen.

Properly shielded and grounded cables and connectors must be used in order to reduce the potential for causing interference to radio and TV communication and to other electrical or electronic equipment. Such cables and connectors are available from IBM authorized dealers. IBM cannot be responsible for any interference caused by using other than recommended cables and connectors.

This product has been tested and found to comply with limits for Class A Information Technology Equipment according to CISPR 22/European Standard EN 55022. The limits for Class A equipment were derived for commercial and industrial environments to provide reasonable protection against interference with licensed communication equipment.

Warning: This is a Class A product. In a domestic environment this product may cause radio interference in which case the user may be required to take adequate measures.

Dieses Gerät erfüllt die Bedingungen der EN 55022 Klasse A. Für diese Klasse von Geräten gilt folgende Bestimmung nach dem EMVG:

communication notices

Geräte dürfen an Orten, für die sie nicht ausreichend entstört sind, nur mit besonderer Genehmigung des Bundesministers für Post und Telekommunikation oder des Bundesamtes für Post und Telekommunikation betrieben werden. Die Genehmigung wird erteilt, wenn keine elektromagnetischen Störungen zu erwarten sind.

(Auszug aus dem EMVG vom 9.Nov.92, Para.3, Abs.4)

Hinweis: Dieses Genehmigungsverfahren ist von der Deutschen Bundespost noch nicht veröffentlicht worden.

Electrical Safety

This printer is inspected and listed by recognized national testing laboratories, such as Underwriters Laboratories, Inc. (UL) in the U.S.A. and Canadian Standards Association (CSA) in Canada. Listing of a product by a national testing laboratory indicates that the product is designed and manufactured in accordance with national requirements intended to minimize safety hazards. IBM equipment meets a very high standard of safety in design and manufacture. Remember, however, that this product operates under conditions of high electrical potentials and heat generation, both of which are functionally necessary.

Trademarks and Service Marks

IBM is a trademark of the IBM Corporation in the United States or other countries or both.

Safety Notices

CAUTION

<1> Before powering on the printer, make sure it is plugged into the appropriate power source.

Refer to the “Select a Site” section in Chapter 2 of the *Setup Guide* for information on proper power sources.

CAUTION

<2> Disconnect the AC power cord before cleaning the printer.

Sikkerhedsinstruktioner

FORSIGTIG

Forvis Dem om, at printeren er tilsluttet den korrekte type strøm, inden De tænder for den.

Korrekt strømtype er specificeret i afsnittet Anbringelse af printeren (Select a Site) i Kapitel 2 i Klargøringsvejledning (Setup Guide).

FARE

Tag stikket ud af kontakten inden De gør printeren ren.

Huomautuksia Turvallisuudesta

VAROITUS

Ennen virran kytkemistä kirjoittimeen on varmistettava, että kirjoitin on liitetty sopivaan virtalähteeseen.

Asennusoppaan (Setup Guide) luvussa 2, kohdassa Asennuspaikan valinta (Select a Site), on tietoja virtalähteen valinnasta.

VAARA

Irrota vaihtovirtajohto ennen kirjoittimen puhdistusta.

Normas de Segurança

ATENÇÃO

Antes de ligar a impressora, certifique-se que esta está ligada ao tipo de corrente apropriado.

Consulte a secção Escolha de Local (Select a Site), do capítulo 2 do Guia de Instalação (Setup Guide), para mais informações sobre os tipos de corrente apropriados para esta impressora.

PERIGO

Desligue o fio de corrente alternada antes de limpar a impressora.

Säkerhetsföreskrifter

VARNING

Innan du kopplar på strömmen till skrivaren ska du kontrollera att den är ansluten till rätt strömförsörjning.

I avsnittet Val av uppställningsplats (Select a Site) i kapitel 2 av Installationsanvisningar (Setup Guide) finns information om rätt strömförsörjning.

FARA

Koppla loss nätkabeln innan du rengör skrivaren.

Sikkerhetsinformasjon

OBS!

Kontroller at skriveren er tilknyttet riktig strømkilde før du slår den på.

Du finner nærmere opplysninger om egnede strømkilder under avsnittet Valg av egnet sted for skriveren (Select a Site) i kapittel 2 i Installasjonshåndboken (Setup Guide).

ADVARSEL

Trekk ut strømledningens støpsel fra stikkontakten før skriveren rengjøres.

注意

プリンタの電源を入れる前に、正しく電源に接続されていることを確認してください。

正しい電源については、「セットアップガイド」の第2章「プリンタの設置」を参照してください。

危険

プリンタを清掃する前に、AC電源ケーブルを抜いてください。

BASIC OPERATING PROCEDURES

- ◆ Powering On the Printer 2
- ◆ Using the Operator Panel 4
- ◆ Changing the Paper Exit Location
(Pedestal Models Only) 19
- ◆ Loading Paper 22
- ◆ Reloading Paper 29
- ◆ Unloading Paper 37
- ◆ Setting Top-of-Form 39
- ◆ Replacing the Ribbon 42
- ◆ Canceling a Print Job 45

Powering On the Printer

caution

Before powering on the printer, make sure it is plugged into the appropriate power source.

Refer to the “Select a Site” section in Chapter 2 of the *Setup Guide* for information on proper power sources.

Push the On (|) side of the switch to power on the printer. Push the Off (○) side of the switch to power off the printer.

Cabinet Models

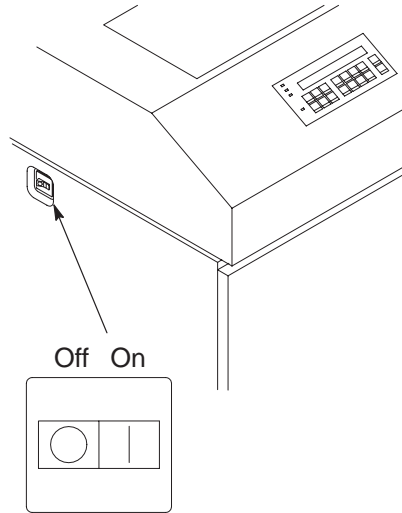

Pedestal Models

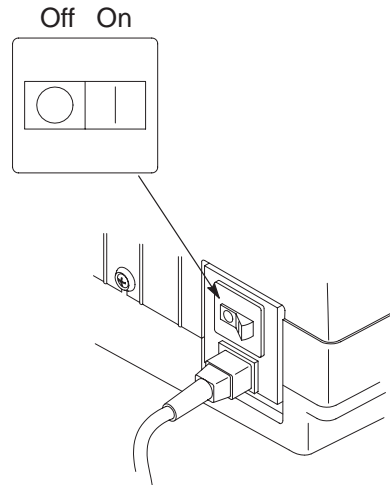

powering on the printer

When you power on the printer, the Power indicator lights and the printer executes a power-on self-test. When the test successfully completes, the printer goes either to READY or NOT READY state, depending on the menu selection. In the READY state, the READY indicator lights and the message "READY" displays.

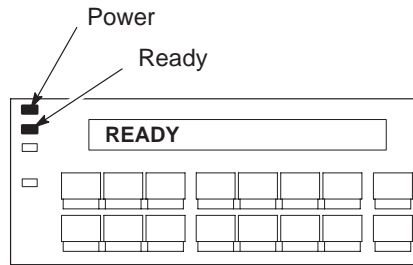

If there is a fault during the self-test, the Attention indicator lights and a fault message (such as "001 END OF FORMS") appears on the message display. See page 76 for information on fault messages.

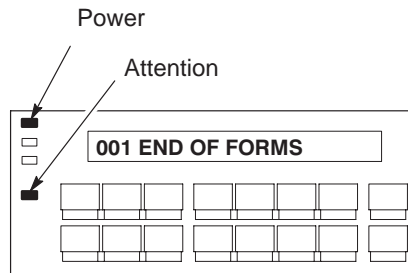

Using the Operator Panel

Use the operator panel to perform routine operations such as:

- Placing the printer in the READY or NOT READY state
- Setting paper position
- Clearing fault conditions
- Configuring the printer
- Running printer self-tests

The printer operating states, status indicators, and operator panel keys are described on the following pages.

Operator Panel Layout

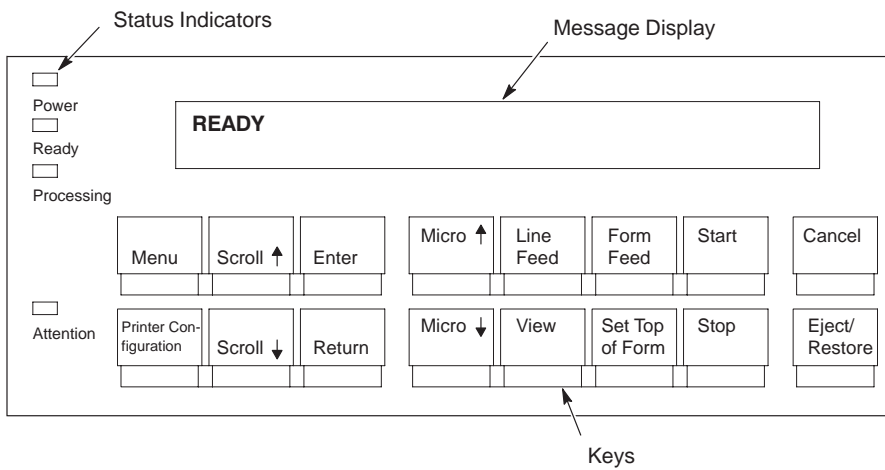

note

Keys, indicators, and messages are shown as they appear on the operator panel. Key combinations are indicated with the plus (+) sign. For example, "Press **Stop + Enter**" means press the **Stop** key and the **Enter** key at the same time.

Operating States

The printer operates in one of the following four states:

- **READY** (on-line) — In READY state, the printer can receive and print data sent from the host. Pressing the **Start** key places the printer in READY state.
- **NOT READY** (off-line) — In NOT READY state, you may perform operator functions such as loading paper and setting top-of-form. Pressing the **Stop** key changes the printer state from READY to NOT READY.
- **PROGRAM** — When the operator menus are displayed, the printer is in program state. Pressing the **Menu** key places the printer in program state and displays the operator menus. Program state may be either locked or unlocked. When program state is unlocked, you may select and save new configuration settings. When program state is locked, you may view the current settings, but cannot change them.
- **FAULT** — When a fault condition exists that must be cleared before printing can continue, the printer is in fault state. When the alarm sounds while the printer is in fault state, pressing any key on the operator panel silences the alarm. (Take care when pressing the **Form Feed** key as the printer will lose top-of-form setting.)

The operating state is generally selected via operator panel keys, as described above. It may also result from routine operations such as powering on the printer, or a fault condition occurring. The existing operating state is frequently indicated as part of the printer display message.



using the operator panel

Message Display

Function Displays operating states, menu options, and fault messages.

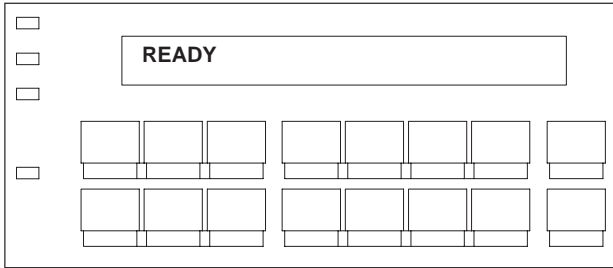

Status Indicators

The operator panel status indicators provide information about existing printer operation, as follows:

- **Power** — Lit when the printer is powered on.
- **Ready** — Lit when the printer is in READY state, no errors are pending, and the printer is ready to process data.
- **Processing** — Flashes when the printer is receiving data from the host.
- **Attention** — Flashes when an error occurs.

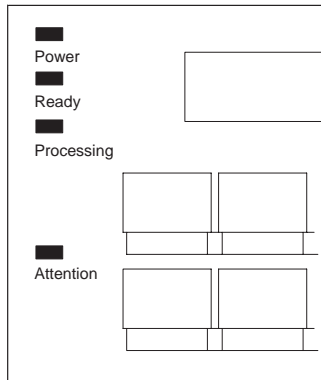

Menu

This key operates only in NOT READY state. Press **Stop** to place the printer in the NOT READY state. (See page 15.)

- 1) Places the printer in program state and displays the first-level operator menu (PRINTER CONTROL).

To view the menus without changing settings, press **Menu** from NOT READY state.

To change the configuration settings, press **Scroll** ↑ + **Scroll** ↓ at the same time to unlock program state; then press **Menu**.

- 2) In program state, press **Scroll** ↑ to move *forward* or **Scroll** ↓ to move *backward* through the options in the existing level of the operator menu.
- 3) Pressing **Enter** moves to a *lower* level in the menu structure; pressing **Return** moves to a *higher* level in the menu structure.

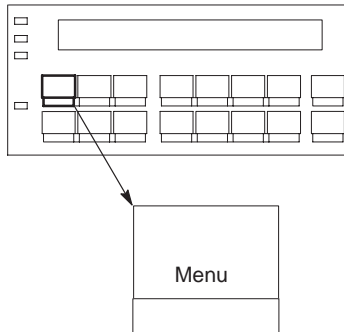

Printer Configuration

This key operates only in NOT READY state. Press **Stop** to place the printer in the NOT READY state. (See page 15.)

In NOT READY state, generates a printed record of the current configuration parameters.

After pressing **Stop**, press **Printer Configuration**. When the display message confirms the **Printer Configuration** key has been activated, press the **Start** key to print the configuration or the **Stop** key to exit the function.

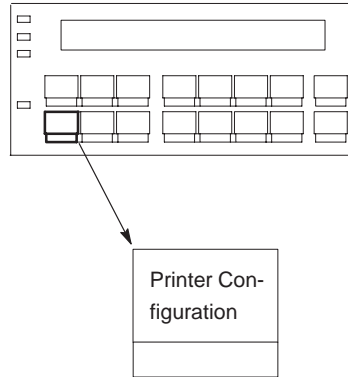

Scroll ↑

This key operates only in NOT READY state. Press **Stop** to place the printer in the NOT READY state. (See page 15.)

In program state, scrolls *forward* through the options in the existing level of the operator menu.

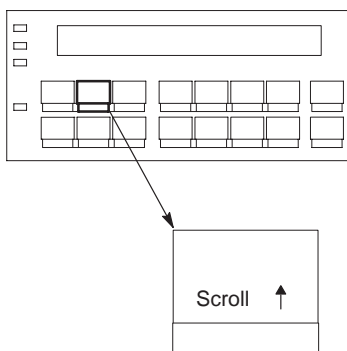

Scroll ↓

This key operates only in NOT READY state. Press **Stop** to place the printer in the NOT READY state. (See page 15.)

In program state, scrolls *backward* through the options in the existing level of the operator menu.

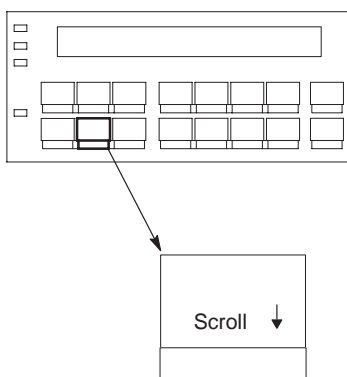

Scroll ↑ + Scroll ↓

In NOT READY state, locks or unlocks the program state.

Press **Scroll ↑ + Scroll ↓** at the same time to switch program state between locked and unlocked.

When program state is locked, no configuration changes can be made. When program state is unlocked, you may select new values from the operator menus using the **Enter** key.



Enter

This key operates only in NOT READY state. Press **Stop** to place the printer in the NOT READY state. (See page 15.)

- 1) In program state, moves to a *lower* level in the menu structure.
- 2) In the “unlocked” program state, selects a configuration option value.
- 3) In program state, starts and stops a Print Test selected from the Operator Print Tests menu.
- 4) In the NOT READY state, pressing **Stop + Enter** performs a soft reset of the printer.

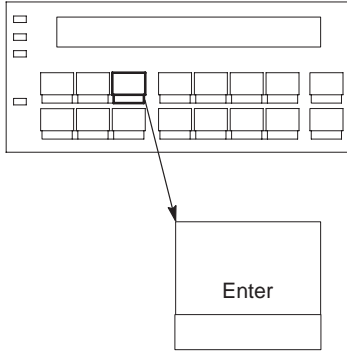

Return

This key operates only in NOT READY state. Press **Stop** to place the printer in the NOT READY state. (See page 15.)

In the program state, moves to a *higher* level in the menu structure.

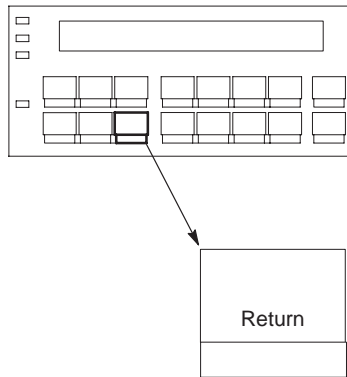

important

Advancing and retracting the paper with these keys changes the printer TOF accordingly.

Micro ↑

This key operates only in NOT READY state. Press **Stop** to place the printer in the NOT READY state. (See page 15.)

In NOT READY state, micro-steps the paper upward in 1/72 inch increments. Press and hold to move paper at 10 increments per second.

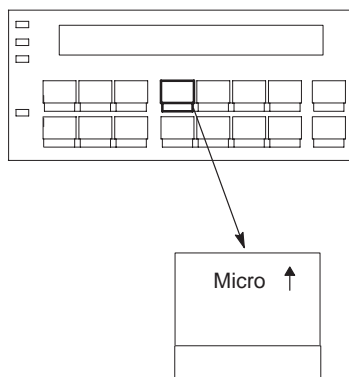

Micro ↓

This key operates only in NOT READY state. Press **Stop** to place the printer in the NOT READY state. (See page 15.)

In NOT READY state, micro-steps the paper downward in 1/72 inch increments. Press and hold to move paper at 10 increments per second.

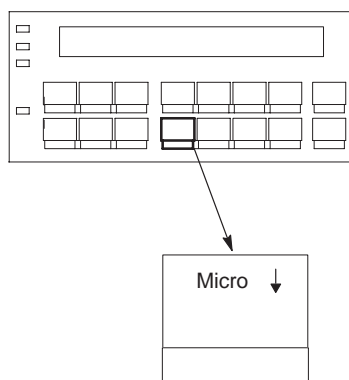

Line Feed

This key operates only in NOT READY state. Press **Stop** to place the printer in the NOT READY state. (See page 15.)

In NOT READY state, press to move the paper up one line, as defined by the existing active line spacing. **Line Feed** will repeat if it is held down.

If there is any data in the buffer, it will print, then the paper will move up one line.

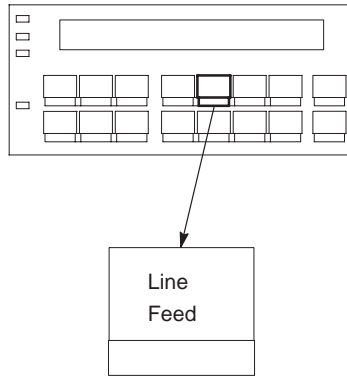

note

The data that prints is all of the data contained in the printer buffer. The data in the attachment buffer is not affected.

View

In NOT READY state, press to move the paper's existing print position up to the tractor area for viewing. This allows you to check the print location. If there is any data left in the buffer, the data will be printed, then the paper will move up for viewing.

Press **View** a second time to move the paper back to its previous print position.

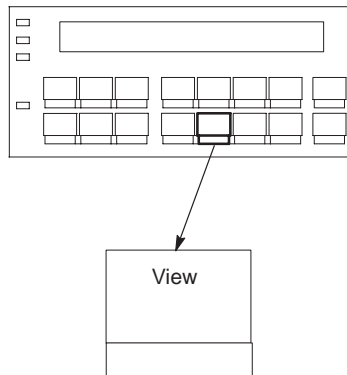

note

*Pressing **Start** instead of pressing **View** a second time moves the paper back to its original print position, and puts the printer in READY state.*

*Pressing **Stop** instead of pressing **View** a second time moves the paper back to its*



NIL

NIL

*original print position, and puts the printer in
NOT READY state.*



Form Feed

This key operates only in NOT READY state. Press **Stop** to place the printer in the NOT READY state. (See page 15.)

In NOT READY state, press and release to move paper to the top-of-form on the next page.

If there is any data in the buffer, it will print first, then the paper will move to the next top-of-form.

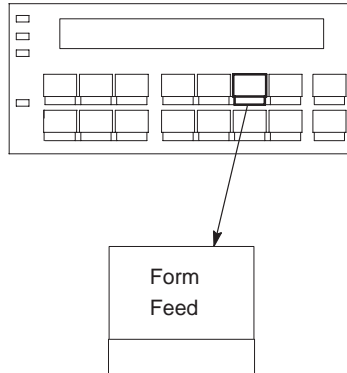

note

The data that prints is all of the data contained in the printer buffer. The data in the attachment buffer is not affected.

Set Top Of Form

This key operates only in NOT READY state. Press **Stop** to place the printer in the NOT READY state. (See page 15.)

Unless there is data in the buffer, this key sets the top-of-form (TOF) by moving the paper down to the print position and setting the emulation to the top-of-form.

See the procedure on page 39 for more information.

If there is data in the buffer (such as after a paper jam), the printer moves to the position where printing stopped.

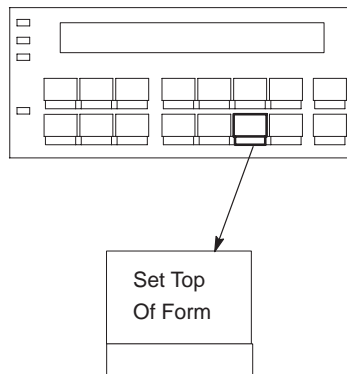

Start

- 1) Moves the printer from NOT READY state to READY state, enabled for printing.
- 2) In program state, exits the menus and places the printer in READY state.
- 3) After pressing **View** or **Eject** to move the print position to the tractor area, moves the paper back to its original print position, and places the printer in READY state.

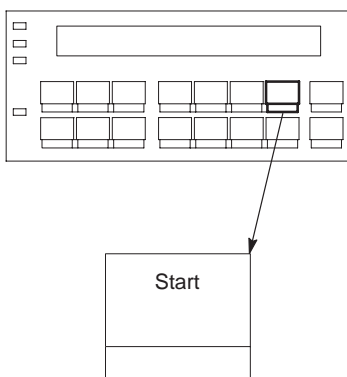

Stop

- 1) Moves the printer from READY state to NOT READY state, enabled for operator functions such as viewing or changing configuration parameters.
- 2) In program state, exits the menus and places the printer in the NOT READY state.
- 3) In fault state, clears the fault if the problem has been corrected.
- 4) In the NOT READY state, pressing **Stop + Enter**, which is a soft reset, resets the printer to the power on configuration.
- 5) After pressing **View** or **Eject** to move the print position to the tractor area, moves the paper back to its original print position, and places the printer in NOT READY state.

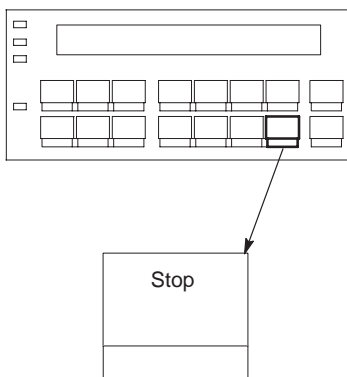

Cancel

important

Use the **Cancel** key carefully to avoid canceling a job accidentally.

- 1) Stops printer tests in progress.
- 2) Cancels a print job. Operation depends on the printer interface.

- a. Coax Interface (non-SCS mode)*:**
In the NOT READY state, the Cancel key is not effective and the 009 Invalid Key is displayed.

note

With a Coax Interface, pressing the **Cancel** key a second time stops the previous cancel.

- b. Coax Interface (SCS mode)*:** Effective in NOT READY state but the action will occur in the READY state only. (When pressed, "059 CANCEL PRINT ACTIVE" is displayed.)

- c. Twinax Interface*:** Effective in READY and NOT READY state. (When pressed, "059 CANCEL PRINT ACTIVE" is displayed.)

- d. Serial/Parallel Interface:** It is recommended that you stop the print job from the host system before pressing **Cancel**. Effective in NOT READY state. (When pressed, "069 DATA CLEARED" is displayed.)

For more information, see page 45, "Canceling a Print Job."

note

The **Cancel** key is not active during **View** and **Eject/Restore** operations.

*To cancel a print job with the Multi-Platform Interface Coax/Twinax feature, see the *Coax/Twinax Multi-Platform Interface Option Installation and Operation Guide*.

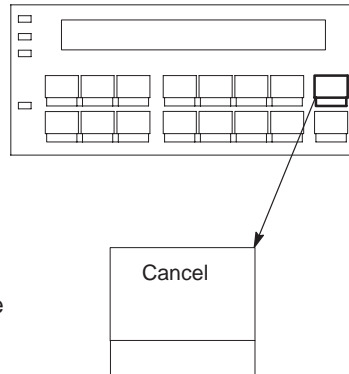

Eject/Restore (Standard Mode)

Standard mode is the only eject/restore mode available on Cabinet Models. For Pedestal Models this mode can be selected from the menu, and should be selected when using the rear exit.

In Standard Mode, this key moves the paper forward to facilitate tearing off the paper at the perforation, then restores the original paper position. In Top Exit Tear Mode (selectable at the operator panel only on the pedestal model), this key restores paper to the top of the next possible form.

In NOT READY state, press **Eject/Restore** to move the paper forward to the tear-off position toward the back of the printer.

Once you have torn the paper at the perforation, press **Eject/Restore**, **Start**, or **Stop** to retract the paper to its previous position, as described below:

- **Eject/Restore** moves the paper to its previous position. The printer returns to the mode it was in before **Eject/Restore** was used.
- **Start** moves the paper to its previous position and the printer goes READY.
- **Stop** moves the paper to its previous position and the printer goes NOT READY.

note

*If you are using this function to tear off forms, you must press **Form Feed** before using the **Eject/Restore** function. This will help avoid unloading the paper as it is restored to its original position.*

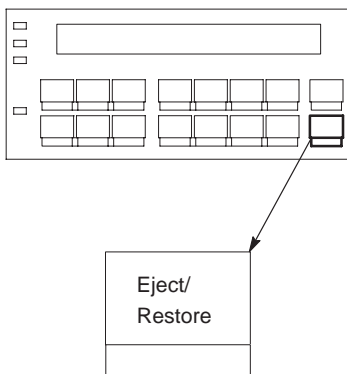

Eject/Restore (Top Exit Tear Mode)

Top Exit Tear Mode is selectable only on pedestal models. It is designed to be used in conjunction with the Top Exit Paper Path. This mode facilitates tearing off forms and adjusting the printer to print on the next available form.

In NOT READY state, press **Eject/Restore** to move the paper forward to the tear-off position.

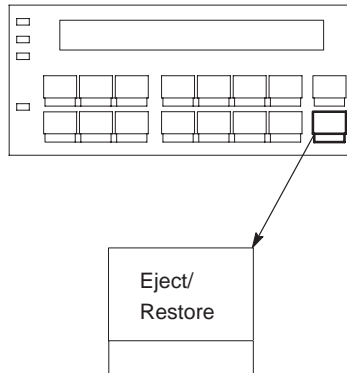

note

When tearing forms from the top exit, pull the form toward you and begin tearing from one corner of the form.

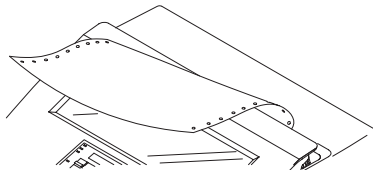

When you have torn the paper at the perforation, press one of the following keys: **Eject/Restore**, **Start**, or **Stop**:

- **Eject/Restore** moves the paper to its next available position. The printer returns to the mode it was in before **Eject/Restore** was used.
- **Start** moves the paper to its next available position and the printer goes READY.
- **Stop** moves the paper to its previous position and the printer goes to NOT READY.

Changing the Paper Exit Location (Pedestal Models Only)

Pedestal model printers feature an adjustment that allows you to select whether the paper exits from the rear or from the top of the printer. Normally, you should select the top exit only when you will be using the forms soon after printing, as forms will not stack when in this mode.

Setting Rear Paper Exit

Use this procedure to change the pedestal printer from top exit to rear exit.

- 1** Press **Stop** to place the printer in NOT READY state.
- 2** If there is paper in the printer, unload the paper (page 37), then continue with step 3 of this procedure.
- 3** Open the printer cover.
- 4** Loosen the two hinge adjustment thumbscrews.
- 5** Slide the cover forward until it stops.

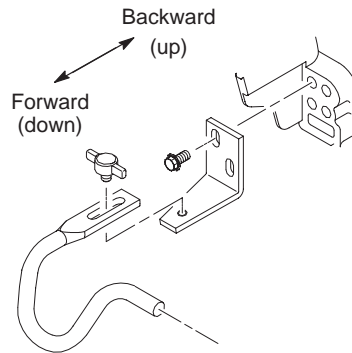

Changing the Paper Exit Location

- 6** Tighten the two hinge adjustment thumbscrews.
- 7** Place the paper guide in its lower position.
- 8** Load paper (page 22), feeding the paper out the rear paper exit.

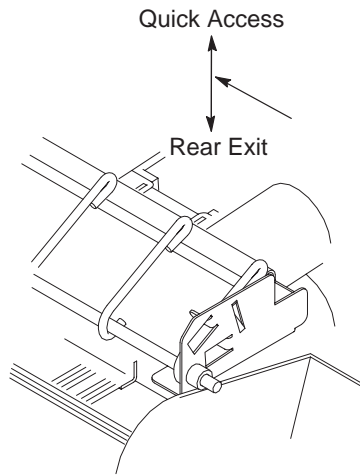

Changing the Paper Exit Location

Setting Top Paper Exit

Use this procedure to change the pedestal printer from rear exit to top exit.

- 1** Press **Stop** to place the printer in NOT READY state.

- 2** If there is paper in the printer, unload the paper (page 37), then continue with step 3 of this procedure.

- 3** Open the printer cover.

- 4** Loosen the two hinge adjustment thumbscrews.

- 5** Slide the cover upward until it stops.

- 6** Tighten the two hinge adjustment thumbscrews.

- 7** Place the paper guide in its upper position.

- 8** Load paper (page 22), feeding the paper out the top paper exit.

Loading Paper

This procedure shows you how to load paper. Use this procedure to load paper into an empty printer, change the paper supply to a different size, or load paper after clearing a paper jam.

note

To reload the paper after an "END OF FORMS" fault message, refer to page 29.

- 1 Press **Stop** to place the printer in NOT READY state.

Open the printer cover.

If necessary, unload the current paper (page 37), then continue with step 3 of this procedure.

- 2 Raise the forms thickness lever as far as it will go.

Open both tractor doors.

Press any key on the operator panel to silence the alarm.

note

Pressing any key on the operator panel will silence the alarm. (Take care when pressing the **Form Feed** key as the top-of-form setting will be lost.)

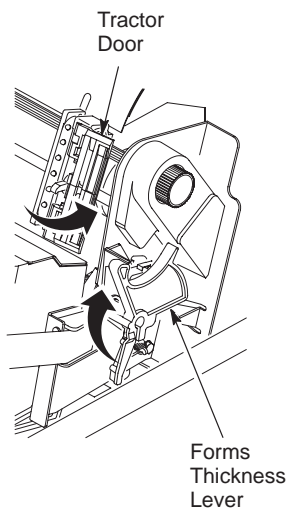

loading paper

- 3** Slide the two paper supports sideways and position them toward the center of the area between the tractors.

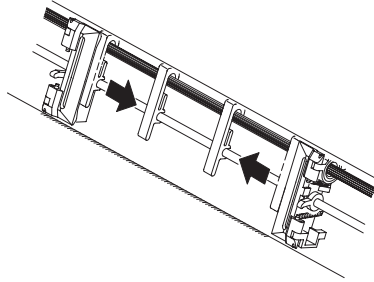

- 4** On cabinet models:
Open the cabinet front door.

Place the paper supply inside the printer, on the floor of the cabinet.

Align the paper supply with the front label on the floor of the printer.

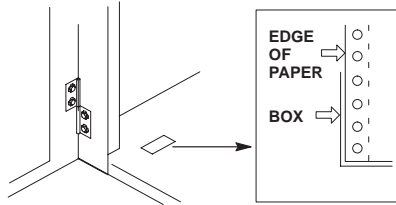

- 5** On pedestal models:
Place the paper supply on the floor in front of the printer, or on the optional input paper shelf.
- 6** Ensure that the paper pulls freely from the box.

loading paper

- 7** Feed the paper up through the paper slot.

On Pedestal models, make sure the paper is inserted between the two wire guides.

Hold the paper in place with one hand (to prevent it from slipping down through the paper slot) and pull it through from above with your other hand.

Cabinet Models

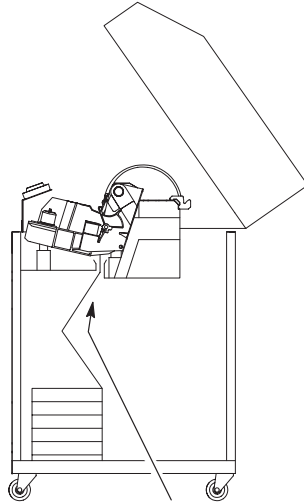

Paper Slot

Pedestal Models

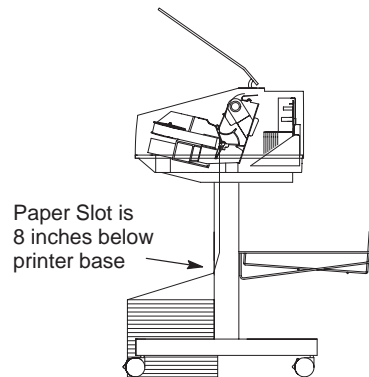

Paper Slot is
8 inches below
printer base

loading paper

- 8** Pull the paper above and behind the ribbon mask. (Refer to the ribbon path diagram on the shuttle cover.)
- 9** Load the paper on the left tractor and close the tractor door.
- 10** You should not normally need to adjust the position of the left tractor.

If adjustment is necessary, unlock the left tractor. Slide the tractor until its inner edge is aligned with the number "1" on the paper scale and lock it.

(You can also use the paper scale to count columns.)

warning

<3> To avoid damage to the printer caused by printing on the platen, always align the edge of the left tractor door with the number "1" on the paper scale.

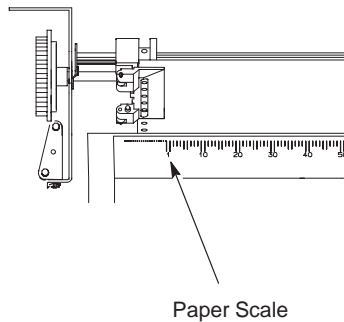
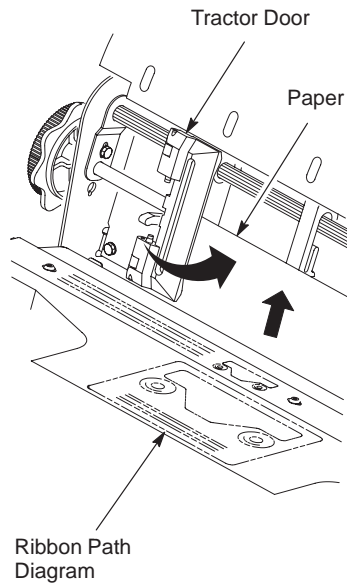

loading paper

- 11 Move the two paper supports as necessary to support the paper through the tractor area.

note

The placement of the paper supports will help the movement of the paper and reduce the possibility of paper jams.

- 12 Unlock the right tractor.

Load the paper on the tractor and close the tractor door.

If necessary, slide the right tractor to remove any slack. The paper should be flat without damaging the form feed holes.

Lock the right tractor. Both tractors are now secured.

After both tractors are secured, you can use the horizontal adjustment knob to make fine horizontal adjustments to the left tractor.

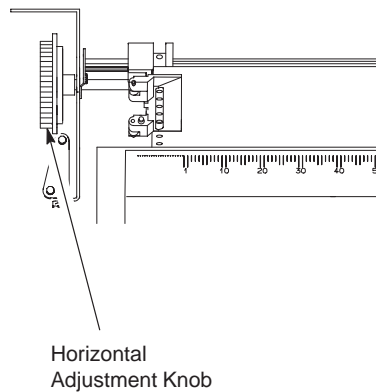
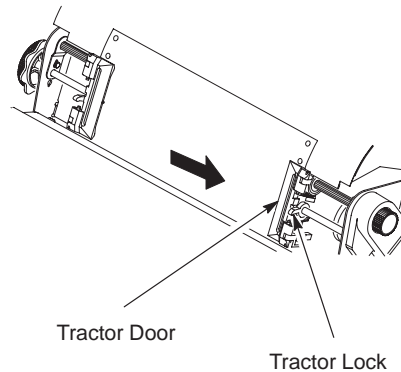

- 13** Lower the forms thickness lever.
Set it to match the paper thickness (refer to the note on the shuttle cover).

note

Do not set the forms thickness lever too tightly; excessive friction can cause paper jams, ribbon jams with potential for ribbon damage, smeared ink, or wavy print.

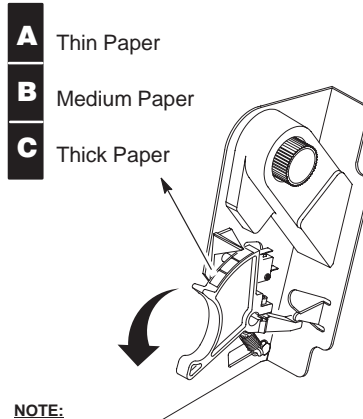

NOTE:

Thin Paper = single sheet
Medium Paper = two-part form
Thick Paper = six-part form

Forms Thickness Lever

- 14** On pedestal models:
Guide the paper over the lower paper guide and through the top or rear paper exit.

Pedestal Models

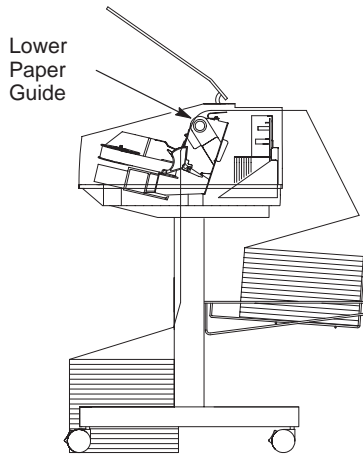

loading paper

15 Do one of the following:

- a.** If there is data in the buffer, such as after a paper jam, go to page 39 to set the top-of-form.
- b.** If there is no data in the buffer, continue with step 16 of this procedure.

16 Press **Form Feed** several times to ensure that the paper feeds properly beyond the tractors, over the lower paper guide, and into the paper stacking area. Feed sufficient paper to ensure that the paper stacks correctly. Ensure that the paper folds the same way in the stacking area as it does in the supply area.

17 On cabinet models:

Open the cabinet rear door. Ensure that the paper is aligned with the label in the output area (inside the cabinet). Close both doors, if the length of your forms allows this. (Some longer forms may require the doors be left open.)

18 Go to page 39 to set the top-of-form.

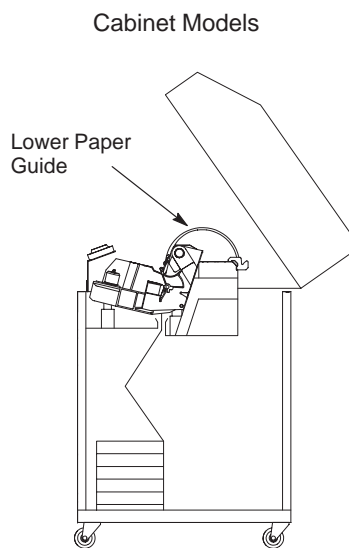



Reloading Paper

Use this procedure when you run out of paper during a print job. The following steps allow you to reload paper without having to reset the top-of-form. The last sheet of the old paper supply is used to line up the first sheet of the new paper supply. This is especially useful when printing forms, such as labels or invoices.

- 1** Raise the printer cover. Raise the forms thickness lever as far as it will go.

Do not open the tractor doors or remove the existing paper.

Press any key on the operator panel except **Form Feed** to silence the alarm.

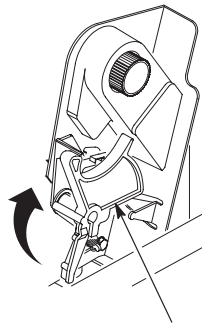

Forms Thickness Lever

note

*Pressing any key on the operator panel will silence the alarm. (Take care when pressing the **Form Feed** key as the top-of-form setting will be lost.)*

- 2** On cabinet models, open the front door.

Align the paper supply with the label on the floor.

Ensure that the paper pulls freely from the box.

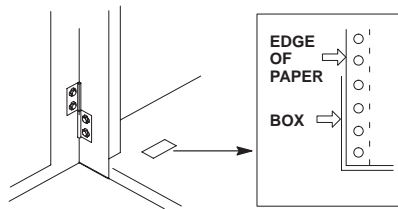

reloading paper

- 3 Locate the paper slot and feed the paper up through the slot.

note

It may be easier to feed one corner of the new paper up through the slot first. When this corner can be grasped from the top, rotate the paper back to the normal position. If necessary, gently press the existing paper back.

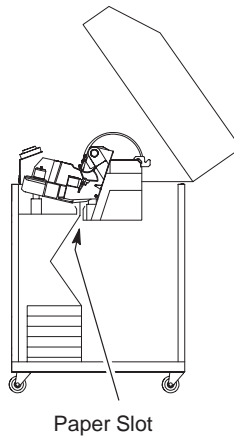

Hold the paper to prevent it from slipping down and through the paper slot.

note

If you are using multi-part paper and it is too thick for the new paper to be loaded over the existing paper, go to step 11.

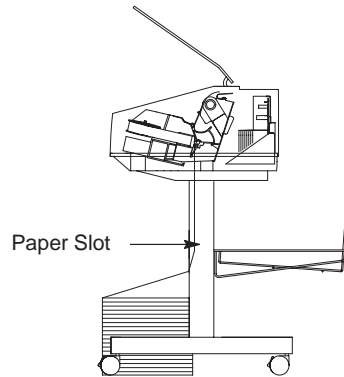

reloading paper

- 4** Pull the new paper above and behind the ribbon mask, but in front of the existing paper. (The ribbon mask location is shown on the ribbon path diagram.)

If necessary, gently press the existing paper back.

Align the top edge of the new paper with the top perforation of the existing paper.

- 5** Load the new paper over the existing paper.

Open and load the tractors one at a time to prevent the paper from slipping.

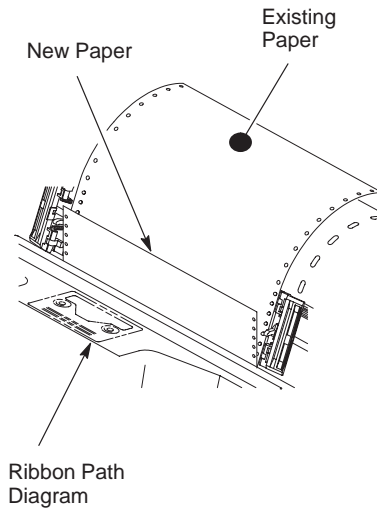

note

Ensure that the top edge of the new paper lines up with the top perforation of the existing paper.

reloading paper

- Lower the forms thickness lever. Set it to match the paper thickness.

(The A–B–C scale corresponds approximately to 1–, 3–, and 6–part paper thickness. Adjust until you have the desired print quality.)

caution

Do not set the forms thickness lever too tightly; excessive friction can cause paper jams, ribbon jams with potential for ribbon damage, smeared ink, or wavy print.

- Press **Cancel** to clear the “END OF FORMS” fault message from the Liquid Crystal Display.

- Close the printer cover.
Close the cabinet front door.

- Press **Start** to place the printer in READY state and resume printing.

- On cabinet models: Open the cabinet back door and ensure that the paper folds in the stacker the same way it does in the supply area, then close the cabinet back door.

Perform steps 11 through 26 only if you are unable to load the new paper over the existing paper in step 3.

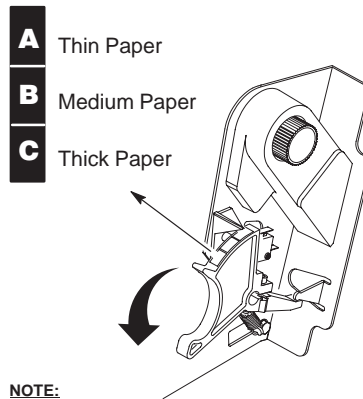

NOTE:

Thin Paper = single sheet
Medium Paper = two-part form
Thick Paper = six-part form

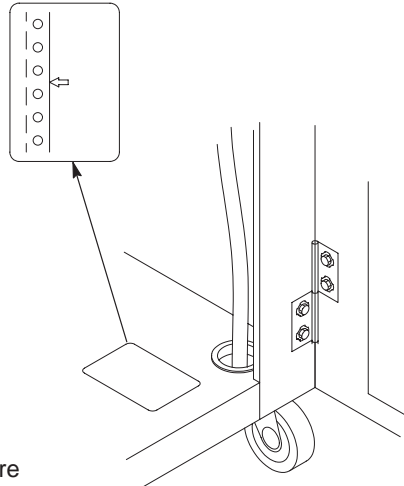

reloading paper

11 Open both tractor doors.

12 Remove the paper from the tractors. Allow the paper to fall into the paper supply area.

13 Feed the paper up through the paper slot inside the cabinet.

Hold the paper to prevent it from slipping down through the paper slot.

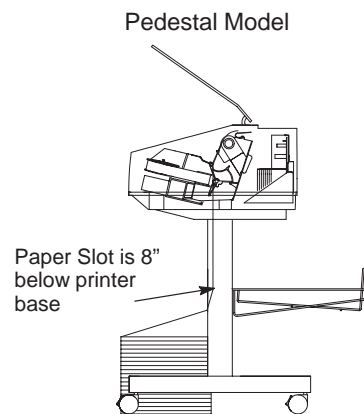
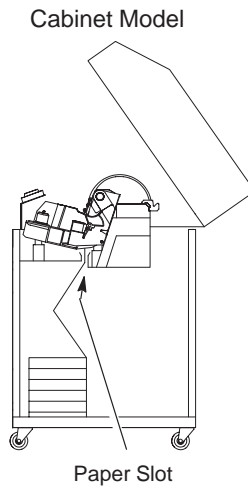

reloading paper

14 Pull the paper above and behind the ribbon mask. (The ribbon mask location is shown on the ribbon path diagram.)

15 Load the paper on the left tractor and close the tractor door.

16 Normally, you should not need to adjust the position of the left tractor.

If adjustment is necessary, unlock the left tractor. Slide the tractor until it is directly to the left of the number "1" on the paper scale and lock it.

(You can also use the paper scale to count columns.)

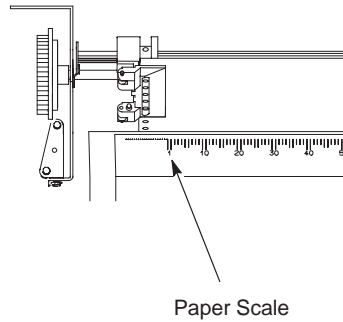
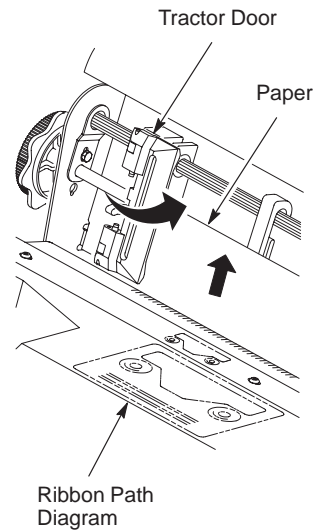

reloading paper

- 17** Move the paper supports as necessary to support the paper through the tractor area.

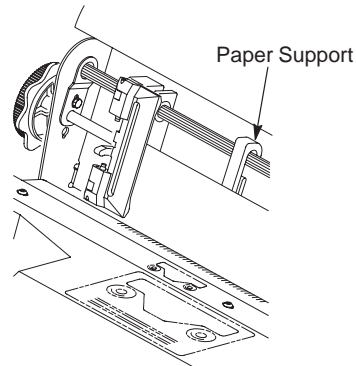

- 18** Unlock the right tractor.

Load the paper onto the sprockets and close the tractor door.

If necessary, slide the right tractor to remove paper slack or to adjust for various paper widths. Then, lock the tractor.

After both tractors are secured, you may use the horizontal adjustment knob to make fine horizontal paper adjustments.

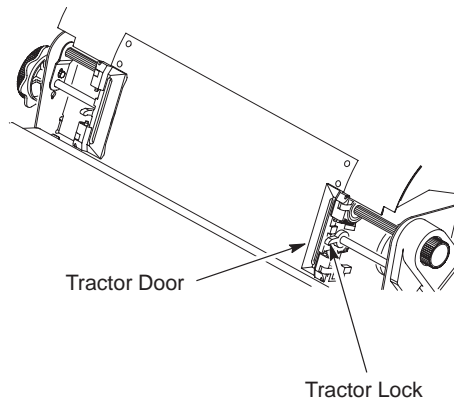

- 19** On pedestal models:
Guide the paper over the lower paper guide and through the slot in the top cover.

- 20** Press **Form Feed** several times to make sure the paper feeds properly beyond the tractors and over the lower paper guide. Feed sufficient paper to ensure the paper stacks correctly.

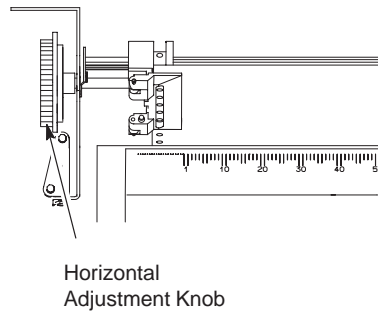

reloading paper

21 On cabinet models:
Make sure the paper is aligned with the label in the output area (inside the cabinet). Close the front door.

22 Align the top of the first print line with the TOF indicator on the tractor by rotating the vertical position knob.

23 Lower the forms thickness lever. Set it to match the paper thickness.

(The A–B–C scale corresponds approximately to 1–, 3–, and 6–part paper thickness. Adjust until you have the desired print quality.)

24 Press **Cancel** to clear any fault messages (such as “END OF FORMS”) from the Liquid Crystal Display.

25 Press **Set Top Of Form**. The top-of-form you have set moves down to the print position.

If there are data in the buffer, the paper moves forward to the last print position on the next page.

26 Press **Start** and close the printer cover.

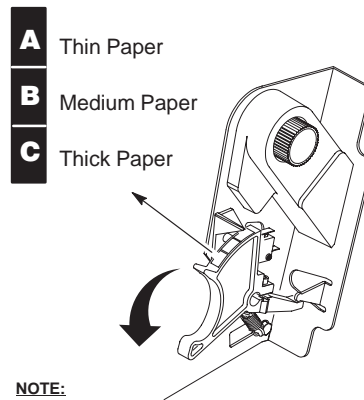
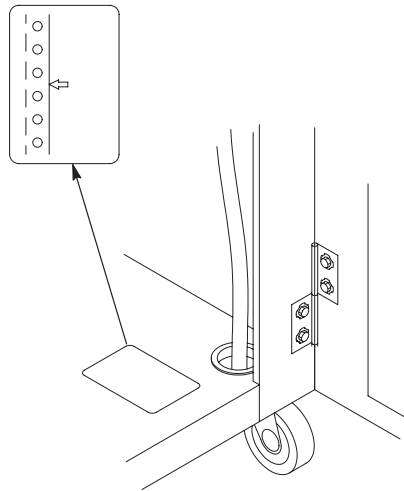

NOTE:

Thin Paper = single sheet
Medium Paper = two-part form
Thick Paper = six-part form

Unloading Paper

- 1 Press **Stop** to place the printer in NOT READY state, and open the printer cover.

- 2 Tear off the paper at the perforation, if necessary.

Allow the paper to fall to the back of the printer and into the paper stacking area.

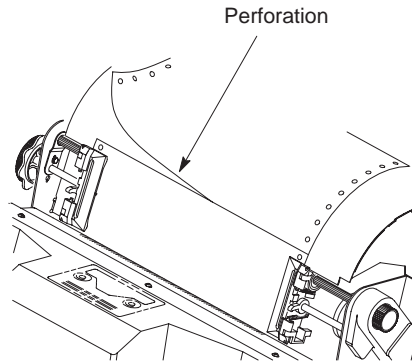

- 3 Raise the forms thickness lever as far as it will go.

Open both tractor doors.

Press any key on the operator panel except **Form Feed** to silence the alarm.

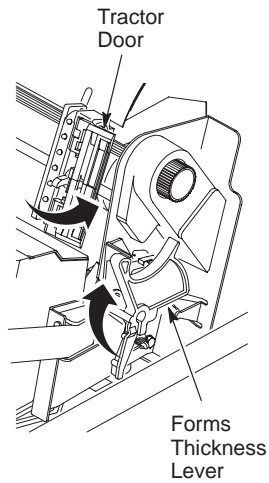

unloading paper

- 4 Remove the paper from the tractors.

- 5 On cabinet models:
Open the cabinet front door.

- 6 For all models, *gently* pull the paper down through the paper slot. Do not let the paper perforations or tractor holes damage the ribbon mask. (Refer to the ribbon path diagram on the shuttle cover.)

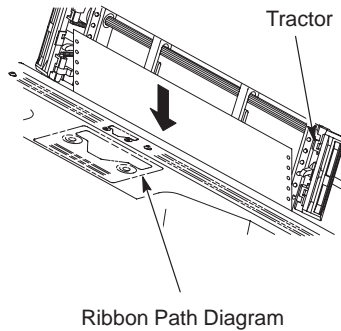

Allow the paper to fall into the paper supply area.

warning

<4> Be careful when pulling any paper backwards through the paper path, especially when using label stock. If you are not careful, labels can detach and adhere to the printer within the paper path, where only an IBM service representative can remove them.

Cabinet Models

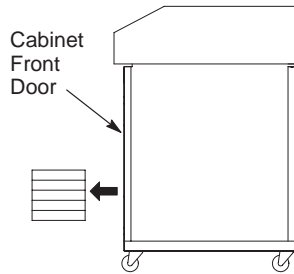

Pedestal Models

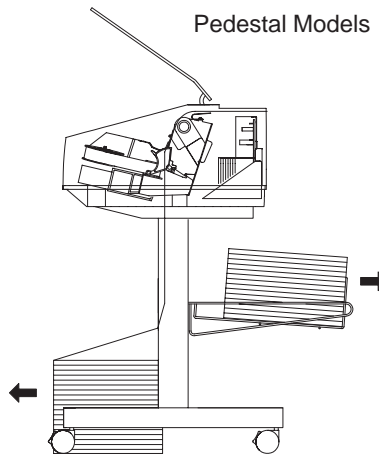

- 7 On cabinet models:
Remove the paper supply from the cabinet floor. Close the cabinet front door and the printer cover.

- 8 On pedestal models:
Remove the paper supply from the floor or shelf in front of the printer and close the printer cover.

Setting Top-of-Form

The top-of-form setting determines where the first line of print appears on a page. Follow this procedure to set the top-of-form.

- 1** If the printer is in READY state, press **Stop** to place the printer in NOT READY state.
- 2** Open the printer cover.
- 3** Raise the forms thickness lever as far as it will go.
- 4** Press any key on the operator panel to silence the alarm.
- 5** Locate the TOF indicator. It is the small tab located on the left tractor door.
- 6** Align the top of the first print line with the TOF indicator on the tractor door by rotating the vertical position knob up or down.

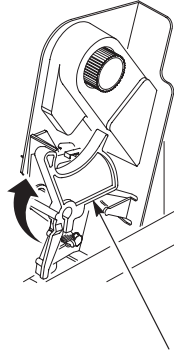

Forms Thickness Lever

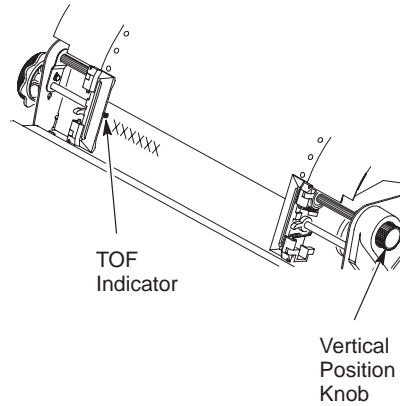

TOF Indicator

Vertical Position Knob

setting top-of-form

- 7** Lower the forms thickness lever. Set it to match the paper thickness (refer to the note on the shuttle cover).

note

Do not set the forms thickness lever too tightly; excessive friction can cause paper jams, ribbon jams with potential for ribbon damage, smeared ink, or wavy print.

- 8** Press **Set Top Of Form**. One of the following occurs:

- a.** If there is no data in the buffer (you have not yet sent a print job to the printer), the paper moves downward to the top-of-form position.

To verify the top-of-form setting, run one of the operator print tests. (See page 63.) Check the placement of the characters on the printout. Your application software may also provide a forms alignment check to verify the placement of the characters.

If the character placement is correct, continue with step 9. Otherwise, go back to step 2.

- b.** If there is data in the buffer (such as after a paper jam), the printer moves to the position where printing stopped. Continue with step 9.

note

After a paper jam, it may be necessary to reprint one or more pages.

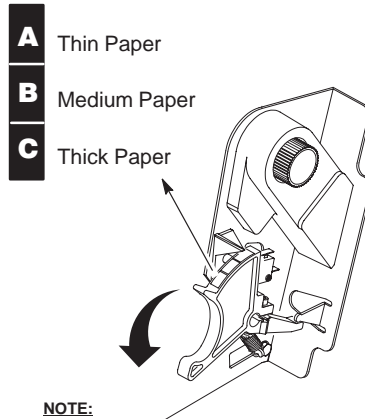

NOTE:

Thin Paper = single sheet
Medium Paper = two-part form
Thick Paper = six-part form

Forms Thickness Lever

9 Close the printer cover.

10 Press **Start** to place the printer in READY state.

11 On cabinet models:

When printing, open the cabinet back door and ensure that the paper folds the same way in the stacking area as it does in the supply area, then close the cabinet back door.

12 On pedestal models:

When printing, ensure that the paper folds the same way in the stacking area as it does in the supply area. Forms are designed to stack only when using the rear exit path. Forms can not be stacked when using the top exit paper path.

Replacing the Ribbon

For detailed ribbon information, refer to your *Setup Guide*. When replacing ribbons, use only the ribbons listed below:

- IBM General Purpose Ribbon, 60yd,
P/N 1040990
- IBM General Purpose Ribbon, 100 yd,
P/N 1040995
- IBM High Contrast Ribbon, 60 yd,
P/N 1040993
- IBM High Contrast Ribbon, 100 yd,
P/N 1040998

Ribbons may be purchased directly from your Lexmark distributor.

- 1** Press **Stop** to place the printer in NOT READY state.

Open the printer cover.

- 2** Remove the old ribbon:

- a.** On pedestal models, raise the operator panel.
- b.** Raise the forms thickness lever as far as it will go.

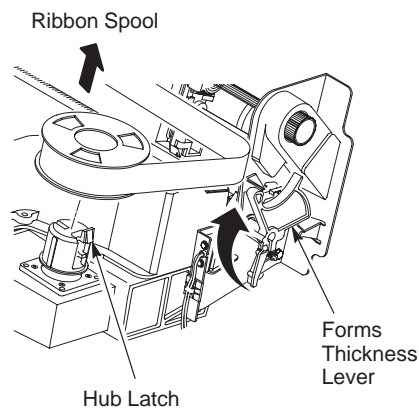

note

*If you are using RibbonMinder and are changing the ribbon because the message Ribbon Out of Ink, Change Ribbon is displayed, raising the forms thickness lever as far as it will go will reset the Ribbon Out of Ink, Change Ribbon fault message. It will also reset the ribbon usage to 100%. If the Ribbon Fault option is set to "Do Nothing," ribbon usage can only be reset from the operator panel by pressing **Enter** with New Ribbon XXX% displayed at the RibbonMinder option.*

- c.** Press any key to silence the alarm. (Take care when pressing the **Form Feed** key as the top-of-form setting will be lost.)
- d.** Press in on the hub latches and lift the ribbon spools off the hubs. Lift the ribbon out of the ribbon path. (Refer to ribbon path diagram on the shuttle cover.)
- e.** Discard the old ribbon.

3 If necessary, clean the interior of the printer. (See page 71.)

4 Install the new ribbon:

- a.** With the ribbon to the outside, place the right spool on the full hub. Press down on the spool until the hub latch snaps in place.
- b.** Install the ribbon around the ribbon guide and along the ribbon path. (Refer to the ribbon path diagram on the shuttle cover.) Be sure to thread the ribbon between the hammer bank cover and the ribbon mask.

warning

<5> **The ribbon must not be twisted. A twisted ribbon can lower print quality, shorten ribbon life, or cause paper jams.**

replacing the ribbon

- c. Place the empty spool on the left hub. Press down on the spool until the hub latch snaps into place. Hand-turn the right spool to ensure that the ribbon tracks correctly in the path and ribbon guides.

- 5 Lower the forms thickness lever. Set it to match the paper thickness.

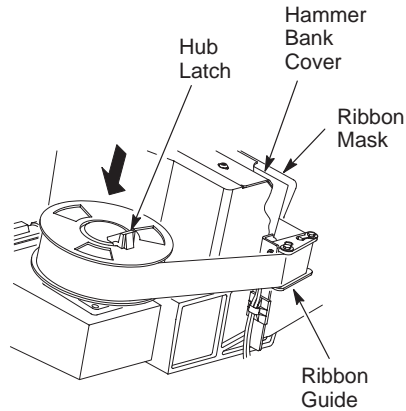

note

Do not set the forms thickness lever too tightly; excessive friction can cause paper jams, ribbon jams with potential for ribbon damage, smeared ink, or wavy print.

- 6 On pedestal models, lower the operator panel.
- 7 Close the printer cover.
- 8 Press **Start** to return the printer to READY state.

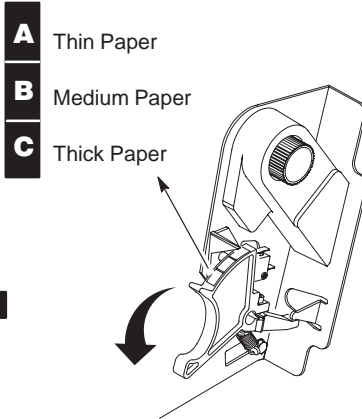

Forms Thickness Lever

NOTE:

Thin Paper = single sheet
Medium Paper = two-part form
Thick Paper = six-part form

note

If you are using RibbonMinder and are changing the ribbon because the message Ribbon Out of Ink, Change Ribbon is displayed, raising the forms thickness lever as far as it will go will reset the Ribbon Out of Ink, Change Ribbon fault message. It will also reset the ribbon usage to 100%. If the Ribbon Fault option is set to "Do Nothing," ribbon usage can only be reset from the operator panel by pressing **Enter** with New Ribbon XXX% displayed at the RibbonMinder option.

Canceling a Print Job

The procedure to cancel a print job depends on the printer interface. See your system administrator for additional information.

note

The **Cancel** key is not active during **View** and **Eject/Restore** operations.

To cancel a print job, choose one of the following steps:

- For printers using a coax interface, in non-SCS mode *:
 - a. The **Cancel** key is not effective. Use the host system to cancel a print job.
- For printers using a coax interface, in SCS mode *:
 - a. Press **Stop** to place the printer in NOT READY state.
 - b. Press **Cancel** to clear the printer buffer. This sends a cancel status message to the host, which clears the print job when the printer is returned to the READY state. (When **Cancel** is pressed, "059 CANCEL PRINT ACTIVE" is displayed. Pressing **Cancel** a second time will cause "CANCEL PRINT INACTIVE" to be displayed.)

Or you may use the host system to cancel a print job.

*To cancel a print job with the Multi-Platform Interface Coax/Twinax feature, see the *Coax/Twinax Multi-Platform Interface Option Installation and Operation Guide*.

canceling a print job

- For printers using a twinax interface *:
 - a.** The **Cancel** key is effective in READY or NOT READY state.
 - b.** Press **Cancel** to clear the printer buffer. This sends a cancel status message to the host, which clears the print job. (When pressed, “059 CANCEL PRINT ACTIVE” is displayed.)

Or you may use the host system to cancel a print job.

- For printers using a serial or parallel interface:
 - a.** Press **Stop** to place the printer in NOT READY state.
 - b.** From the host system, stop the print job.

note

*If the print job is not stopped from the host system before pressing the **Cancel** key, the print job will continue when the printer returns to READY state.*

- c.** Press **Cancel**. (When pressed, “069 DATA CLEARED” is displayed.)
- d.** Set the top-of-form as described on page 39.

*To cancel a print job with the Multi-Platform Interface Coax/Twinax, see the *Coax/Twinax Multi-Platform Interface Option Installation and Operation Guide*.



CONFIGURATIONS

- ◆ Parameters and Configurations 49
- ◆ Saving Configurations 51
- ◆ Recalling Configurations 53
- ◆ Deleting Configurations 55
- ◆ The Power-On Configuration 57
- ◆ Protecting Custom Sets 59
- ◆ Printing Configurations 61
- ◆ Operator Print Tests 63



Parameters and Configurations

Printer parameters are settings such as lines per inch (lpi), characters per inch (cpi), typeface, etc.

A configuration is a group of parameters. For example:

- 8 lpi
- 10 cpi
- Data processing typeface, etc.

Changing Parameters

You can change a parameter by pressing keys on the operator panel or by sending a control code from the host computer.

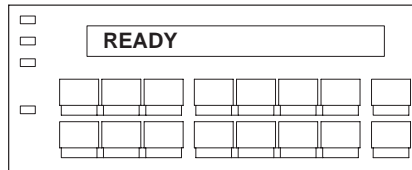

The parameter is active as long as the printer is on and a reset from the host or a “soft reset” (**START** and **ENTER** keys are pressed) from the operator panel is not performed.



Control Codes

Control codes override parameters that were changed with the operator panel. For example, if you set line spacing to 6 lpi with the operator panel and application software later changed this to 8 lpi with a control code, the 8 lpi would be the new, active parameter.

The 8 lpi parameter is effective as long as the printer is on. To save the 8 lpi parameter, you must use the operator panel and save it as a custom set.

The Configurations

There are nine configuration sets available for use. They are: a factory default, four custom, and four custom/preloaded sets.

note

The factory default custom set cannot be modified or overwritten.

Custom Sets 1–4 can be configured for specific print job requirements.

Custom/Preloaded Sets 5–8 contain configuration sets that assist with the installation and configuration of this printer. For more information, refer to your *Setup Guide*.

You can load or overwrite any of these eight custom sets.

You can also modify the eight configurations and overwrite old parameters.

The following pages describe how to perform these functions.

To change individual parameters, such as line spacing, typeface, etc., refer to your *Setup Guide*.

Saving Configurations

You can save your unique custom sets by following these procedures. Custom sets are stored in Non-Volatile Random Access Memory (NVRAM) for permanent storage and will not be lost if you power off the printer.

- 1** Press **Stop** to place the printer in the NOT READY state.

NOT READY

- 2** Press **Scroll** ↑ + **Scroll** ↓ at the same time to unlock the program state.

OPERATOR MENU
UNLOCKED

- 3** Press **Menu** to access the OPERATOR MENU.

OPERATOR MENU
PRINTER CONTROL

- 4** Press **Scroll** ↑ to scroll forward until you reach CONFIGURATION MANAGEMENT.

OPERATOR MENU
CONFIGURATION MANAGEMENT

- 5** Press **Enter** to enter this menu.

CONFIGURATION MANAGEMENT
RECALL CUSTOM SET

- 6** Press **Scroll** ↑ to reach SAVE CURRENT VALUES.

CONFIGURATION MANAGEMENT
SAVE CURRENT VALUES



saving configurations

7 Press **Enter** to access the save options.

SAVE CURRENT VALUES
CUSTOM SET 1*

8 Press **Scroll** ↑ repeatedly until the custom set you want to save displays.

SAVE CURRENT VALUES
CUSTOM SET 2

important

Do not power off the printer while save is in progress because you might lose your configuration.

9 Press **Enter** to select the custom set. An asterisk (*) appears next to the selected set in the display.

SAVE CURRENT VALUES
CUSTOM SET 2*

10 Press **Scroll** ↑ + **Scroll** ↓ at the same time to lock the program state.

OPERATOR MENU
LOCKED

SAVE CURRENT VALUES
CUSTOM SET 2*

11 Press **Start** to exit the menu and place the printer in READY state.

READY





Recalling Configurations

You can recall any of the custom sets you previously stored, or the factory default configuration. (See page 51 to save configurations.)

The following example loads Custom Set 1.

- 1** Press **Stop** to place the printer in the NOT READY state.

NOT READY

- 2** Press **Scroll ↑ + Scroll ↓** at the same time to unlock the program state.

OPERATOR MENU
UNLOCKED

- 3** Press **Menu** to access the OPERATOR MENU.

OPERATOR MENU
PRINTER CONTROL

- 4** Press **Scroll ↑** to scroll forward until you reach CONFIGURATION MANAGEMENT.

OPERATOR MENU
CONFIGURATION MANAGEMENT

- 5** Press **Enter** to enter this menu.

CONFIGURATION MANAGEMENT
RECALL CUSTOM SET

- 6** Press **Enter** to access the recall options.

RECALL CUSTOM SET
FACTORY DEFAULT*



recalling configurations

- 7** Press **Scroll** ↑ repeatedly until the custom set you want to load displays.

RECALL CUSTOM SET
CUSTOM SET 1

- 8** Press **Enter**. This selects the displayed custom set.

LOADING SAVED CONFIGURATION

RECALL CUSTOM SET
CUSTOM SET 1*

- 9** Press **Scroll** ↑ + **Scroll** ↓ at the same time to lock the program state.

OPERATOR MENU
LOCKED

RECALL CUSTOM SET
CUSTOM SET 1*

- 10** Press **Start** to return the printer to the READY state.

READY



Deleting Configurations

You can delete any of your custom sets. Factory default, the factory-preset configuration, cannot be deleted.

The following example deletes Custom Set 3.

- 1** Press **Stop** to place the printer in the NOT READY state.

NOT READY

- 2** Press **Scroll** ↑ + **Scroll** ↓ at the same time to unlock the program state.

OPERATOR MENU
UNLOCKED

- 3** Press **Menu** to access the OPERATOR MENU.

OPERATOR MENU
PRINTER CONTROL

- 4** Press **Scroll** ↑ to scroll forward until you reach CONFIGURATION MANAGEMENT.

OPERATOR MENU
CONFIGURATION MANAGEMENT

- 5** Press **Enter** to enter this menu.

CONFIGURATION MANAGEMENT
RECALL CUSTOM SET

- 6** Press **Scroll** ↑ to reach DELETE CUSTOM SET.

CONFIGURATION MANAGEMENT
DELETE CUSTOM SET

- 7** Press **Enter** to access the delete options.

DELETE CUSTOM SET
1*





deleting configurations

8 Press **Scroll** ↑ repeatedly until the custom set you want to delete displays.

DELETE CUSTOM SET
3

9 Press **Enter**. This deletes the custom set.

DELETING CONFIGURATION

DELETE CUSTOM SET
3*

10 Press **Scroll** ↑ + **Scroll** ↓ at the same time to lock the program state.

OPERATOR MENU
LOCKED

DELETE CUSTOM SET
3*

11 Press **Start** to return the printer to the READY state.

READY

note

If the custom set you choose to delete has not previously been saved, the following error message displays, "042 CUSTOM SET DOES NOT EXIST/SAVE FIRST."





The Power-On Configuration

When you power on the printer for the first time, it loads the factory default configuration.

If you save a custom set, such as Custom Set 4, and turn the printer off, then back on, the printer will load the designated power-on configuration, not the last saved custom set.

For your convenience, you can specify which custom set should be the power-on set.

- 1** Press **Stop** to place the printer in the NOT READY state.

NOT READY

- 2** Press **Scroll** ↑ + **Scroll** ↓ at the same time to unlock the program state.

OPERATOR MENU
UNLOCKED

- 3** Press **Menu** to access the OPERATOR MENU.

OPERATOR MENU
PRINTER CONTROL

- 4** Press **Scroll** ↑ to scroll forward until you reach CONFIGURATION MANAGEMENT.

OPERATOR MENU
CONFIGURATION MANAGEMENT

- 5** Press **Enter** to enter this menu.

CONFIGURATION MANAGEMENT
RECALL CUSTOM SET



the power-on configuration

- 6** Press **Scroll** ↑ repeatedly until you reach the CHANGE POWER ON SET parameter.

CONFIGURATION MANAGEMENT
CHANGE POWER ON SET

- 7** Press **Enter** to access the power-on options.

CHANGE POWER ON SET
FACTORY DEFAULT

- 8** Press **Scroll** ↑ until you reach the custom set you want to save as the power-on set.

CHANGE POWER ON SET
CUSTOM SET 4

- 9** Press **Enter** to select the Custom Set. An asterisk (*) appears next to the selected set in the display.

CHANGE POWER ON SET
CUSTOM SET 4*

- 10** Press **Scroll** ↑ + **Scroll** ↓ at the same time to lock the program state.

OPERATOR MENU LOCKED

CHANGE POWER ON SET
CUSTOM SET 4*

- 11** Press **Start** to return the printer to READY state.

READY



Protecting Custom Sets

When the Protect Custom Sets parameter is enabled, you will not be able to overwrite or delete an existing custom set.

- 1** Press **Stop** to place the printer in the NOT READY state.

NOT READY

- 2** Press **Scroll** ↑ + **Scroll** ↓ at the same time to unlock the program state.

OPERATOR MENU
UNLOCKED

- 3** Press **Menu** to access the OPERATOR MENU.

OPERATOR MENU
PRINTER CONTROL

- 4** Press **Scroll** ↑ to scroll forward until you reach CONFIGURATION MANAGEMENT.

OPERATOR MENU
CONFIGURATION MANAGEMENT

- 5** Press **Enter** to enter this menu.

CONFIGURATION MANAGEMENT
RECALL CUSTOM SET

- 6** Press **Scroll** ↑ until you reach PROTECT CUSTOM SETS.

CONFIGURATION MANAGEMENT
PROTECT CUSTOM SETS

- 7** Press **Enter** to access the protect options.

PROTECT CUSTOM SETS
DISABLE*



protecting custom sets

- 8** Press **Scroll** ↑ (this toggles between DISABLE and ENABLE).

PROTECT CUSTOM SETS
ENABLE

- 9** Press **Enter** to select ENABLE. An asterisk (*) appears next to the word ENABLE.

PROTECT CUSTOM SETS
ENABLE*

- 10** Press **Scroll** ↑ + **Scroll** ↓ at the same time to lock the program state.

OPERATOR MENU
LOCKED

PROTECT CUSTOM SETS
ENABLE*

- 11** Press **Start** to exit the menu and place the printer in the READY state.

READY



Printing Configurations

The Print Custom Set Values option allows you to print the various stored printer parameters: current, factory, power-on custom sets, or all of the custom sets.

note

You can press the **Printer Configuration** key to obtain a printout of the current configuration. (Save this printout as it is useful information for your IBM Service Representative.)

- 1** Press **Stop** to place the printer in the NOT READY state.

NOT READY

- 2** Press **Scroll ↑ + Scroll ↓** at the same time to unlock the program state.

OPERATOR MENU
UNLOCKED

- 3** Press **Menu** to access the OPERATOR MENU.

OPERATOR MENU
PRINTER CONTROL

- 4** Press **Scroll ↑** to scroll forward until you reach CONFIGURATION MANAGEMENT.

OPERATOR MENU
CONFIGURATION MANAGEMENT

- 5** Press **Enter** to enter this menu.

CONFIGURATION MANAGEMENT
RECALL CUSTOM SET

- 6** Press **Scroll ↑** repeatedly until you reach the PRINT CUSTOM SET VALUES parameter.

CONFIGURATION MANAGEMENT
PRINT CUSTOM SET VALUES



printing configurations

7 Press **Enter** to access the print options.

PRINT CUSTOM SET VALUES
CURRENT CUSTOM SET*

8 Press **Scroll** ↑ repeatedly until you reach the custom set you want to print.

PRINT CUSTOM SET VALUES
CUSTOM SET 6

note

To print all of the custom sets, press **Scroll** ↑ until ALL CUSTOM SETS is displayed.

PRINT CUSTOM SET VALUES
CUSTOM SET 6*

9 Press **Enter** to select the option. An asterisk (*) appears next to the selected set in the display.

NOT READY

10 Your configuration is printed. The printer returns to the NOT READY state.

OPERATOR MENU
LOCKED

11 Press **Scroll** ↑ + **Scroll** ↓ at the same time to lock the program state.

READY

12 Press **Start** to exit the menu and place the printer in the READY state.



Operator Print Tests

This procedure describes how to run the operator print tests. Although you may run these tests at any time, to obtain predictable results, all tests should be run while no data is in the print buffer. The following tests may be run: Printer Demonstration, Print Error Log, Ripple Print, All E's, All H's, All E's & FF and Underlines.

In the following procedure, printing the error log is shown as an example.

- 1** Press **Stop** to place the printer in the NOT READY state.

NOT READY

- 2** Press **Scroll** ↑ + **Scroll** ↓ at the same time to unlock the program state.

OPERATOR MENU
UNLOCKED

- 3** Press **Menu** to access the OPERATOR MENU.

OPERATOR MENU
PRINTER CONTROL

- 4** Press **Scroll** ↑ to scroll forward to the OPERATOR PRINT TESTS menu.

OPERATOR MENU
OPERATOR PRINT TESTS

- 5** Press **Enter** to enter this menu.

OPERATOR PRINT TESTS
PRINTER DEMONSTRATION*

- 6** Press **Scroll** ↑ until you reach the test you want to run.

OPERATOR PRINT TESTS
PRINT ERROR LOG



operator print tests

- 7** Press **Enter**. The test runs. To halt the test, press **Enter** again.

Additional tests can be run by returning to step 6.

OPERATOR PRINT TESTS
PRINT ERROR LOG*

- 8** Press **Stop** to place the printer in NOT READY state.

NOT READY

- 9** Press **Start** to place the printer in READY state.

READY



TROUBLESHOOTING

- ◆ Clearing Paper Jams 67
- ◆ Cleaning the Printer 70
- ◆ Solving Printer Problems 74
- ◆ Fault Messages 76



Clearing Paper Jams

Perform the following steps to clear a paper jam.

warning

<4> Be careful when pulling paper backwards through the paper path, especially when using label stock. If you are not careful, labels may detach and adhere to the printer within the paper path, where only an IBM service representative can remove them.

- 1 Open the printer cover.
- 2 Raise the forms thickness lever as far as it will go.

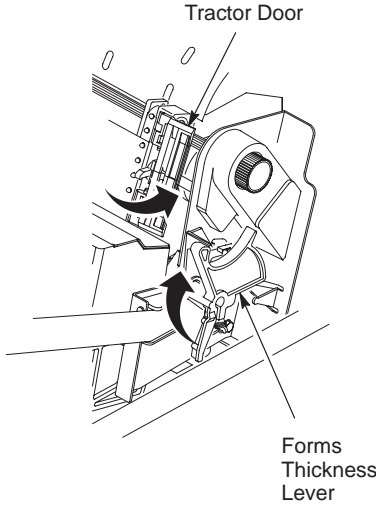

note

Press any key on the operator panel to silence the alarm. (Take care when pressing the **Form Feed** key as the top-of-form setting will be lost.)

- 3 Open both tractor doors.
- 4 Check the paper path and tractors for jammed or torn paper. Remove any pieces of paper by turning the vertical position knob.

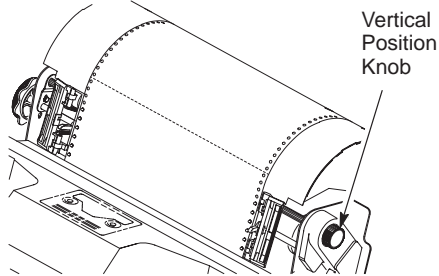

clearing paper jams

- 5** Check that the ribbon mask has not been deformed in such a way as to block the paper path. (If the ribbon mask is damaged or bent, contact an IBM service representative.)
- 6** Check the narrow paper path between the face of the platen and the ribbon mask for pieces of torn paper and ribbon lint. Refer to the ribbon path diagram on the shuttle cover.
- 7** Reload the paper on the tractors.
- 8** Lower the forms thickness lever. Set it to match the paper thickness (refer to the note on the shuttle cover).

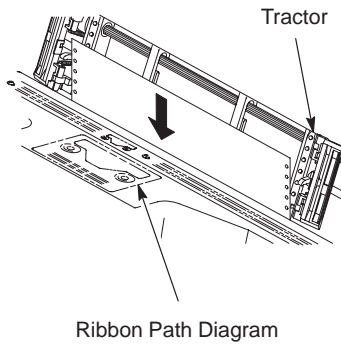

note

Do not set the forms thickness lever too tightly; excessive friction can cause paper jams, ribbon jams with potential for ribbon damage, smeared ink, or wavy print.

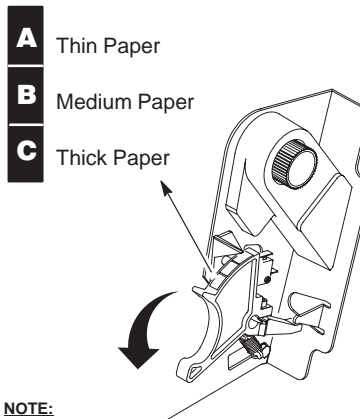

NOTE:

Thin Paper = single sheet
Medium Paper = two-part form
Thick Paper = six-part form

Forms Thickness Lever

- 9** Press **Stop** to clear the fault message from the message display.
- 10** Set the top-of-form (page 39).
- 11** Close the printer cover.
- 12** Press **Start**.
- 13** On cabinet models:
Open the cabinet back door.

Ensure that the paper folds the same way in the stacking area as it does in the supply area.

Ensure that the paper is aligned with the label in the output area (inside the cabinet).

Close the cabinet back door, if the length of your forms allows this. (Some longer forms require the back door to be left open.)

- 14** On pedestal models:
When printing, ensure that the paper folds the same way in the stacking area as it does in the supply area. Forms are designed to stack only when using the rear exit path. Forms can not be stacked when using the top exit paper path.

Cleaning the Printer

Periodic cleaning ensures efficient operation and clear print quality.

caution

<2> Disconnect the power source before cleaning the printer.

Cleaning the Outside of the Printer

Clean the outside of the printer with a soft, lint-free cloth and mild detergent. (Dishwashing liquid works well.) Do not use abrasive powders or chemical solvents. Clean the windows with plain water or mild window cleaner.

warning

<6> Always apply the cleaning solution to the cloth; never pour cleaning solution directly onto the printer.

Cabinet Models

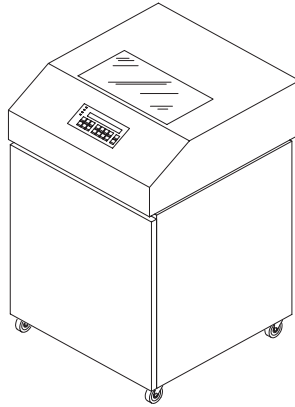

Pedestal Models

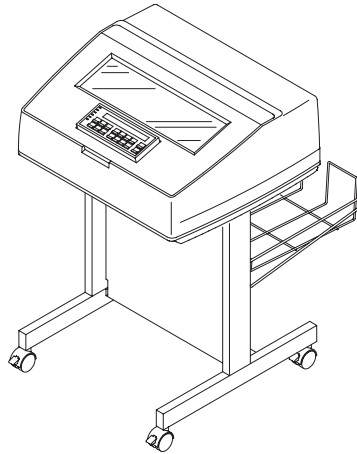

Cleaning Inside the Printer

caution

<2> Disconnect the power source before cleaning the printer.

Over time, it is normal for particles of paper and ink to accumulate inside the printer. Paper dust and ink build-up must be removed periodically to avoid degraded print quality. To clean the interior of the printer, perform the following steps.

- 1** Power off the printer and unplug the power cord.
- 2** Unload the paper supply (page 37).
- 3** Remove the ribbon (page 42).

cleaning the printer

warning

<2> To avoid damage to the printer, be extremely careful when vacuuming and dusting around the hammer bank and surrounding areas.

4 Using a soft-bristled, non-metallic brush, remove dust particles from the paper path, ribbon guides, and ribbon path. (Refer to the ribbon path diagram on the shuttle cover.)

5 Brush and vacuum accumulated dust or residue, especially in the tractor, hammer bank, and base pan areas.

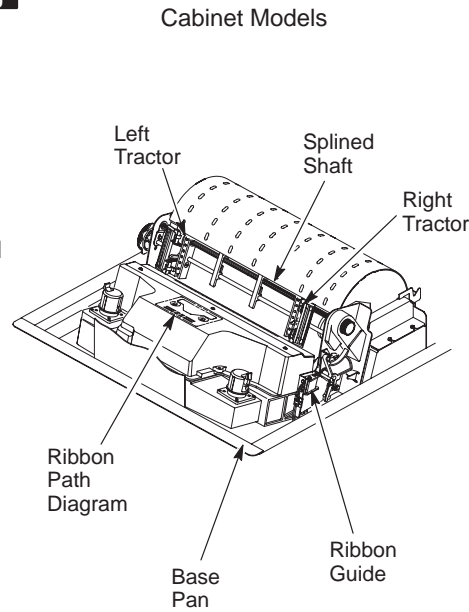

Pedestal Models

6 Wipe the splined shaft with a soft cloth.

7 Using a soft cloth lightly moistened with anhydrous alcohol, clean the ribbon guides and platen.

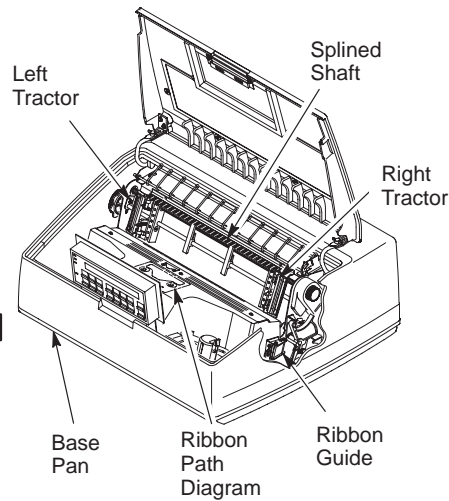

warning

<1> Do not let anhydrous alcohol drip into the hammer bank.

cleaning the printer

- 8** On cabinet models:
Brush and vacuum inside the lower cabinet.

Wipe the lower cabinet interior with a clean, lint-free cloth damp (not wet) with water and mild detergent. Dry the lower cabinet interior with a dry, clean, lint-free cloth.

- 9** On pedestal and cabinet models:
Reinstall the ribbon (page 43), load the paper (page 22), and set the top-of-form (page 39).

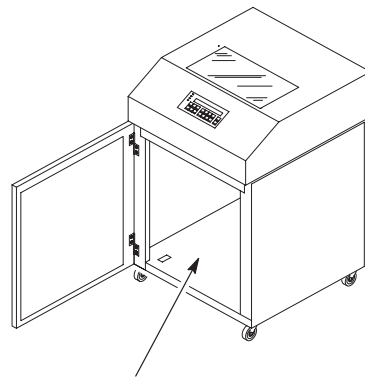

Interior of
Lower
Cabinet

Solving Printer Problems

If you are having print quality or other problems, locate your printer problem in the table below and do the Corrective Action. If more than one corrective action task is listed, test the printer after each task. If the problem persists, contact an IBM service representative.

Problem	Corrective Action
Poor print quality: dark print light print light print on half the page missing dots or characters smeared print wavy vertical lines	<ol style="list-style-type: none"> 1 Adjust the forms thickness lever setting. (Print quality can be affected if it is too loose or too tight.) 2 Adjust the paper tension horizontally by moving the right tractor. (Print quality can be affected if it is too loose or too tight.) 3 Make sure the ribbon threads around the ribbon guides and between the hammer bank cover and ribbon mask, as shown on the ribbon path diagram. Turn the ribbon spools to ensure that the ribbon tracks correctly in the ribbon path. 4 Clean the printer (see page 70). 5 Replace the ribbon (page 42) with an approved ribbon.
Torn or damaged forms	<ol style="list-style-type: none"> 1 Reset the forms thickness lever for thicker paper. 2 Check the paper slot for foreign material. 3 For thick, multipart forms, set the SET PLATEN AT BOTTOM OF FORM parameter to OPEN. (See Chapter 4, "Configuration Menus," in the <i>Setup Guide</i>.)
Loss of forms position	<ol style="list-style-type: none"> 1 Set the forms thickness lever for thicker paper.
<i>continued next page</i>	

solving printer problems

Problem	Corrective Action
Lost dots (incompletely formed characters)	<ol style="list-style-type: none"> 1 Lower the forms thickness lever. 2 Adjust the paper tension horizontally by moving the right tractor. (Print quality can be affected if it is too loose or too tight.) 3 Clear the paper path of any obstructions. 4 If problems persist, contact an IBM Service Representative.
Horizontally or vertically misaligned character positions	
Erratic character height	
Vertically deformed print	
Asterisk does not appear after you change a configuration parameter with the Enter key.	<ol style="list-style-type: none"> 1 Press Stop to place the printer in the NOT READY state. Press Scroll ↑ + Scroll ↓ at the same time to unlock the program state. The message "OPERATOR MENU UNLOCKED" will appear briefly. Press Menu to access the OPERATOR MENU. Display the configuration option you want to change. Press Enter when the option is on the message display.
The configuration printout does not represent configuration parameters selected and changed.	<ol style="list-style-type: none"> 1 Verify that you have saved the current configuration (see page 51).

Fault Messages

When a fault message occurs, the **Attention** indicator flashes, the alarm sounds (if the alarm option is set to ENABLE), and a specific message appears in the display. When this happens, correct the fault immediately.

note

*If the alarm sounds, press any key on the operator panel to silence the alarm. (Take care when pressing the **Form Feed** key as the top-of-form setting will be lost.)*

You can correct most faults by performing a simple procedure, such as clearing a paper jam or reloading paper. For more serious faults, however, call an IBM service representative.

Fault Ranking

The message display shows only one error at a time. If multiple errors occur, the errors are prioritized to determine which error is displayed. After one error is fixed, the next error is displayed.

Fault Correction Procedure

- 1** Press any key except **Form Feed** to silence the alarm if necessary.
- 2** Write down the number of the displayed error message.
- 3** Read the fault explanation, then proceed to fix the problem, if possible.
- 4** Press **Stop** to clear the fault message. Press **Start** to return to Ready state, and resume printing.
- 5** If the fault message reappears, power off the printer, wait 15 seconds, then power on the printer.
- 6** Run your print job again. If the fault message reappears, turn off power to the printer, then call your IBM service representative. Otherwise, no further attention is required.

The following pages list each printer status message and fault message. For fault messages, suggestions are offered for correcting the fault condition.

fault messages

001 END OF FORMS
LOAD FORMS

001 End of Forms

Printer is out of paper. Load paper according to instructions on page 22.

002 FORMS JAMMED
CLEAR JAM AND RELOAD FORMS

002 Forms Jammed

No paper motion. Clear paper jam according to instructions on page 67, then reload paper. Reset forms thickness lever.

003 FORMS EJECTED
PRESS EJECT/RESTORE

003 Forms Ejected

Non-error status message. Press **Eject/Restore** or **Start/Stop** key to return paper to print position.

004 VIEW FORMS
PRESS VIEW KEY

004 View Forms

Non-error status message. Press **View** key to return paper to print position.

006 HOST SYSTEM REQUEST ATTENTION

006 Host System Request Attention

Host attention message. The host computer or printer controller requires attention.

007 FM HEADER ERROR

007 FM Header Error

Format header error. Applications software has violated format header parameters. Contact your system administrator.

fault messages

008 HOLD PRINT TIMEOUT
PRESS START

008 Hold Print Timeout

Printer was off-line more than 10 minutes and the "Intervention Required" parameter is set to "Send to Host". Press **Start** to put printer in READY state.

009 INVALID KEY PRESS

009 Invalid Key Press

Appears briefly if an inactive key is pressed in current print mode. Re-enter the value, or press the correct key.

010 PARAMETER ERROR

010 Parameter Error

Illegal parameter value received in command code. Contact your system administrator.

011 SCS COMMAND ERROR

011 SCS Command Error

Printer received undefined control character. Contact your system administrator

012 STRUCTURED FIELD ERROR

012 Structured Field Error

Applications software has violated structured data field parameters. Contact your system administrator.

013 ACTIVATE LOST

013 Activate Lost

Printer detects twinax protocol communication error. The printer reports the error.

fault messages

014 INVALID ACTIVATE

014 Invalid Activate

Printer detects twinax protocol communication errors. The printer reports the error.

015 COMMUNICATION CHECK
CHECK CABLE

015 Communication Check

Line not active. (Twinax interface) Check cable connection.

016 INVALID COMMAND

016 Invalid Command

Printer detects twinax protocol communication errors. The printer reports the error; host action is required.

021 RECEIVE BUFFER OVERRUN
VERIFY CONFIGURATION

021 Receive Buffer Overrun

Receive overrun. (Serial interface) Check printer serial port configuration setup. Ensure that baud rate matches both host and printer settings.

022 UNIT ADDRESS NOT RECEIVED
CHECK PRINTER ADDRESS

022 Unit Address Not Received

Unit address not recognized by printer. Ensure that printer address matches host setting.

024 SERIAL LINE PARITY ERROR
VERIFY CONFIGURATION

024 Serial Line Parity Error

Parity error. (Serial interface) Check printer serial port configuration setup. Ensure that parity setting matches both host and printer settings.

fault messages

025 SERIAL FRAMING ERROR
VERIFY CONFIGURATION

025 Serial Framing Error

Framing error. (Serial interface) Check printer serial port configuration setup. Ensure that it matches host setting.

026 HEX DUMP MODE

026 Hex Dump Mode

Printer attach status message. No action necessary.

027 COMMUNICATIONS CHECK
CALL SYSTEM OPERATOR

027 Communications Check

Enable poll timeout. The printer was not enabled for one minute. (Coax interface) Check cable connection and host system.

028 COMMUNICATIONS CHECK
CALL SYSTEM OPERATOR

028 Communications Check

Poll timeout error. The printer was not polled for one minute. (Coax interface) Check cable connection and host system.

029 8344 DIAGNOSTIC TEST FAILED

029 8344 Diagnostic Test Failed

Link-level code detects hardware failure. Contact your IBM service representative.

031 END OF FORMS TIMEOUT
LOAD FORMS

031 End of Forms Timeout

A timeout message is sent to the host if paper is not loaded 10 minutes after **Stop** was pressed to clear the paper out fault. The Intervention Required parameter is set to Send to Host. Load paper. See page 22 for procedure.

fault messages

**032 FORMS JAMMED TIMEOUT
CLEAR JAM AND RELOAD FORMS**

032 Forms Jammed Timeout

A timeout message is sent to the host if no paper motion has occurred for 10 minutes after **Stop** was pressed to clear the jam fault. The Intervention Required parameter is set to Send to Host. Clear paper jam and reload paper. See page 67 for procedure.

041 BUFFER OVERFLOW

041 Buffer Overflow

Host sends data after the printer buffer is full. (Serial interface) Check printer serial port configuration setup. Ensure that the Data Terminal Ready setting matches both host and printer settings.

**042 CUSTOM SET DOES NOT EXIST
SAVE FIRST**

042 Custom Set Does Not Exist

This custom set does not exist. Define and save it. (Refer to the *Setup Guide*.)

**043 CUSTOM SET ALREADY EXISTS
DELETE EXISTING SET FIRST**

043 Custom Set Already Exists

Custom set is write-protected. Delete existing set, then save new set. (Refer to the *Setup Guide*.)

044 EC FIRMWARE/HARDWARE ERROR

044 EC Firmware/Hardware Error

Fatal firmware error on the controller board. Contact your IBM service representative.

fault messages

046 EC STOPPED AT STATE

<state>

046 EC Stopped at State

Controller self-test and initialization sequence were halted at <state>, where <state> is one of 10 numerically coded messages. Contact your IBM service representative.

056 HAMMER COIL OPEN*056 Hammer Coil Open*

Electrical malfunction of one or more hammer coils. Contact your IBM service representative.

057 CLOSE PLATEN*057 Close Platen*

Forms thickness lever is raised to the open position. Lower the forms thickness lever.

058 SHUTTLE JAM*058 Shuttle Jam*

No shuttle movement or the shuttle is moving at the wrong speed. Make sure the ribbon is not twisted and the forms thickness lever is set to match thickness of media being used. If the fault reoccurs, contact an IBM service representative.

059 CANCEL PRINT ACTIVE*059 Cancel Print Active*

Non-error status message displayed when SCS print job is cancelled. No action necessary.

060 PRINTER HOT*060 Printer Hot*

Controller board sensors report high temperatures on the board. Contact your IBM service representative.

fault messages

062 EXHAUST FAN FAULT

062 Exhaust Fan Fault

Sensors cannot detect current in fan circuit. Refer to the *Setup Guide* for correction procedure. If this message appears on a Pedestal model, contact your IBM service representative.

063 INTAKE FAN FAULT

063 Intake Fan Fault

Sensors cannot detect current in fan circuit. Refer to the *Setup Guide* for correction procedure.

065 HAMMER BANK FAN FAULT

065 Hammer Bank Fan Fault

Sensors cannot detect current in fan circuit. Refer to the *Setup Guide* for correction procedure.

069 DATA CLEARED

069 Data Cleared

Appears when data is cleared out of printer after **Cancel** key has been pressed. No action necessary.

080 POWER SUPPLY HOT

080 Power Supply Hot

Circuits are overheating on the power supply board. Contact your IBM service representative.

082 POWER SUPPLY 8.5V FAILED

082 Power Supply 8.5V Failed

Internal power failure. Contact your IBM service representative.

fault messages

084 POWER SUPPLY 48V FAILED

084 Power Supply 48V Failed

Internal power failure. Contact an IBM service representative.

085 CONTROLLER VOLTAGE

085 Controller Voltage

Controller voltage failure. Contact your IBM service representative.

086 CONTROLLER 15V

086 Controller 15V

Controller voltage failure. Contact your IBM service representative.

**087 PLATEN OPEN TIMEOUT
CLOSE PLATEN**

087 Platen Open Timeout

Indicates the forms thickness lever has been open for at least one minute. The Intervention Required parameter is set to Send to Host. Close forms thickness lever.

088 CONTROLLER 23.5V

088 Controller 23.5V

Controller voltage failure. Contact your IBM service representative.

089 RIBBON STALL

089 Ribbon Stall

No ribbon movement. Make sure the ribbon is not twisted and the forms thickness lever is set to match thickness of media being used. If fault reoccurs, contact your IBM service representative.

fault messages

**090 SHUTTLE COVER OPEN
CLOSE SHUTTLE COVER**

090 Shuttle Cover Open

Shuttle cover is missing, damaged, or not correctly installed. Contact your IBM service representative.

092 RIBBON DRIVER CIRCUIT

092 Ribbon Driver Circuit

Controller board does not detect ribbon drive motor. Contact your IBM service representative.

101 UPPER DRIVER SHORT

101 Upper Driver Short

Hammer driver circuits on the controller board shorted to ground. Contact your IBM service representative.

102 LOWER DRIVER SHORT

102 Lower Driver Short

Circuit(s) on the hammer bank or in the hammer bank power cable shorted to ground. Contact your IBM service representative.

fault messages

107 HAMMER COIL HOT

107 Hammer Coil <number> Hot

One or more hammer coils are overheating. Stop printing and allow the printer to cool for five minutes. If the fault reoccurs, contact an IBM service representative.

110 STACK OVERFLOW

SEE USER'S GUIDE

110 Stack Overflow

Fatal firmware error on the controller board. Contact your IBM service representative.

111 STACK UNDERFLOW

SEE USER'S GUIDE

111 Stack Underflow

Fatal firmware error on the controller board. Contact your IBM service representative.

112 UNDEFINED OPCODE

SEE USER'S GUIDE

112 Undefined OP Code

Fatal firmware error on the controller board. Contact your IBM service representative.

113 PROTECTED INSTRUCTION

SEE USER'S GUIDE

113 Protected Instruction

Fatal firmware error on the controller board. Contact your IBM service representative.

114 ILLEGAL OPERAND ACCESS

SEE USER'S GUIDE

114 Illegal Operand Access

Fatal firmware error on the controller board. Contact your IBM service representative.

fault messages

115 ILLEGAL INSTRUCTION ACCESS
SEE USER'S GUIDE

115 Illegal Instruction Access
Fatal firmware error on the controller board. Contact your IBM service representative.

116 ILLEGAL EXTERNAL BUS ACCESS
SEE USER'S GUIDE

116 Illegal External Bus Access
Fatal firmware error on the controller board. Contact your IBM service representative.

117 A TO D OVERRUN
SEE USER'S GUIDE

117 A to D Overrun
Fatal firmware error on the controller board. Contact your IBM service representative.

fault messages

118 UNDEFINED INTERRUPT
SEE USER'S GUIDE

118 Undefined Interrupt
Fatal firmware error on the controller board. Contact your IBM service representative.

119 TCB CORRUPTED
SEE USER'S GUIDE

119 TCB Corrupted
Fatal firmware error on the controller board. Contact your IBM service representative.

120 ACCESS NULL POINTER
SEE USER'S GUIDE

120 Access Null Pointer
Fatal firmware error on the controller board. Contact your IBM service representative.

121 PAPER NOT AT SPEED
SEE USER'S GUIDE

121 Paper Not at Speed
Fatal firmware error on the controller board. Contact your IBM service representative.

122 PAPER NOT SCHEDULED
SEE USER'S GUIDE

122 Paper Not Scheduled
Fatal firmware error on the controller board. Contact your IBM service representative.

123 PAPER BUSY TOO LONG
SEE USER'S GUIDE

123 Paper Busy Too Long
Fatal firmware error on the controller board. Contact your IBM service representative.

fault messages

124 PAPER FIFO OVERFLOW
SEE USER'S GUIDE

124 Paper FIFO Overflow
Fatal firmware error on the controller board. Contact your IBM service representative.

125 PAPER FIFO UNDERFLOW
SEE USER'S GUIDE

125 Paper FIFO Underflow
Fatal firmware error on the controller board. Contact your IBM service representative.

126 PAPER FEED BAD TABLE
SEE USER'S GUIDE

126 Paper Feed Bad Table
Fatal firmware error on the controller board. Contact your IBM service representative.

127 PAPER FEED ILLEGAL STATE
SEE USER'S GUIDE

127 Paper Feed Illegal State
Fatal firmware error on the controller board. Contact your IBM service representative.

128 PAPER FEED INVALID COMMAND
SEE USER'S GUIDE

128 Paper Feed Invalid Command
Fatal firmware error on the controller board. Contact your IBM service representative.

129 PAPER FEED INVALID PARAMETER
SEE USER'S GUIDE

129 Paper Feed Invalid Parameter
Fatal firmware error on the controller board. Contact your IBM service representative.

fault messages

130 PAPER FEED PARTLY ENERGIZED
SEE USER'S GUIDE

130 Paper Feed Partly Energized
Fatal firmware error on the controller board. Contact your IBM service representative.

131 PAPER FEED INTERRUPT
SEE USER'S GUIDE

131 Paper Feed Interrupt
Fatal firmware error on the controller board. Contact your IBM service representative.

132 RIBBON INVALID COMMAND
SEE USER'S GUIDE

132 Ribbon Invalid Command
Fatal firmware error on the controller board. Contact your IBM service representative.

133 RIBBON INVALID STATE
SEE USER'S GUIDE

133 Ribbon Invalid State
Fatal firmware error on the controller board. Contact your IBM service representative.

134 PLATEN INVALID COMMAND
SEE USER'S GUIDE

134 Platen Invalid Command
Fatal firmware error on the controller board. Contact your IBM service representative.

135 PLATEN INVALID STATE
SEE USER'S GUIDE

135 Platen Invalid State
Fatal firmware error on the controller board. Contact your IBM service representative.

fault messages

136 PLATEN INVALID PARAMETER
SEE USER'S GUIDE

136 Platen Invalid Parameter
Fatal firmware error on the controller board. Contact your IBM service representative.

137 SHUTTLE INVALID COMMAND
SEE USER'S GUIDE

137 Shuttle Invalid Command
Fatal firmware error on the controller board. Contact your IBM service representative.

138 SHUTTLE INVALID PARAMETER
SEE USER'S GUIDE

138 Shuttle Invalid Parameter
Fatal firmware error on the controller board. Contact your IBM service representative.

139 SHUTTLE OVERSPEED
SEE USER'S GUIDE

139 Shuttle Overspeed
Fatal firmware error on the controller board. Contact your IBM service representative.

990 MACHINE CHECK

990 Machine Check
Host status message. No action necessary.

998 NON-VOLATILE MEMORY FAILED

998 Non-Volatile Memory Failed
Non-volatile memory fault. Contact your IBM service representative. NOTE: You can still print, but you cannot save configuration changes as the NVRAM is defective.

fault messages

A97 GRAPHIC CHECK ERROR
PRESS STOP THEN START

A97 Graphic Check Error
Printer has received a non-printable character. Press **Stop** then **Start**.

BUFFER REPRINT SELECTED

Buffer Reprint Selected
Status message. No action necessary.
Message only appears when using Coax SCS Mode.

ENERGY SAVER MODE ACTIVE

Energy Saver Mode Active
Status message: printer is in low-energy idle state, all fans and higher voltages are off, only +5 Vdc logic circuits are active. No action necessary.

HAMMER COIL BAD
#, #, #, #

Hammer Coil Bad
Malfunction of one or more hammer coils. Bad coils are indicated. Contact your IBM service representative.

NOT READY

Not Ready
Printer state message: printer is offline, not in communication with host. No action necessary.

OPERATOR MENU
<first menu item>

Operator Menu
Non-error status message. No action necessary.

OPERATOR MENU LOCKED

Operator Menu Locked
Non-error status message. No action necessary.

fault messages

OPERATOR MENU UNLOCKED	<i>Operator Menu Unlocked</i> Non-error status message. No action necessary.
PA1 SELECTED	<i>PA1 Selected</i> Status message. No action necessary. Message only appears when using Coax SCS Mode.
PA2 SELECTED	<i>PA2 Selected</i> Status message. No action necessary. Message only appears when using Coax SCS Mode.
P05 DIAGNOSTIC TEST PASSED	<i>P05 Diagnostic Test Passed</i> Non-error status message. No action necessary.
P17 SECURITY VIOLATION	<i>P17 Security Violation</i> Security code of PAL on controller board does not match firmware code. Contact your IBM service representative.
PLEASE WAIT... RESET IN PROGRESS	<i>Please Wait... Reset In Progress</i> Printer reset in progress. No action necessary.
READY	<i>Ready</i> Printer state message: printer is online and in communication with host. No action necessary.

fault messages

RIBBON INK OUT
CHANGE RIBBON

Ribbon Ink Out, Change Ribbon
RibbonMinder has determined that the ribbon is out of ink. Change the ribbon and verify that ribbon life is reset to 100%.

SERVICE MENU
<first service test>

Service Menu <first service test>
Non-error status message. No action necessary.

TESTING HARDWARE
PLEASE WAIT

Testing Hardware Please Wait
Status message when printer runs self-tests and initialization routines. No action necessary.

TOP OF FORM SET

Top of Form Set
Non-error status message. No action necessary.

L

└

©Copyright IBM Corp., 1995, 1996, 1997



S246-0115-02