

6400 Line Matrix Printers



# Setup Guide

Cabinet and Pedestal Models







6400 Line Matrix Printer

S246-0116-02

## **Setup Guide**

Cabinet and Pedestal Models

**Note!**

Before using the information and the product it works with, ensure that you read the general information under “Notices” on page x.

**Third Edition (January, 1997)**

The following paragraph does not apply to any country where such provisions are inconsistent with local law.

INTERNATIONAL BUSINESS MACHINES CORPORATION PROVIDES THIS PUBLICATION “AS IS” WITHOUT WARRANTY OF ANY KIND, EITHER EXPRESS OR IMPLIED, INCLUDING, BUT NOT LIMITED TO THE IMPLIED WARRANTIES OF MERCHANTABILITY OR FITNESS FOR A PARTICULAR PURPOSE. Some states do not allow disclaimer of express or implied warranties in certain transactions, therefore, this statement may not apply to you. Requests for IBM publications should be made to your IBM representative or to the IBM branch office serving your locality. Publications are not stocked at the address given below.

A Readers’ Comments form is provided at the back of this publication. You may send your comments by facsimile to 1-800-524-1519, by E-mail to *print\_pubs@vnet.ibm.com*, or by mail to:

IBM PRINTING SYSTEMS COMPANY  
DEPARTMENT H7FE BUILDING 003G  
INFORMATION DEVELOPMENT  
PO BOX 1900  
BOULDER, CO  
80301-9191  
USA

When you send information to IBM or IBM Printing Systems Company, you grant a nonexclusive right to use or distribute the information in any way IBM or IBM Printing Systems Company believes appropriate without incurring any obligation to you.

© **Copyright International Business Machines Corporation 1995, 1996, 1997.**

Note to U.S. Government Users – Documentation related to restricted rights – Use, duplication or disclosure is subject to restrictions set forth in GSA ADP Schedule Contract with IBM Corp.

# Table of Contents

---

## **1 Introduction**

Chapter Contents .....	1-1
About This Setup Guide .....	1-2
How to Locate Information .....	1-2
Notes and Notices .....	1-2
Format Conventions .....	1-3
Related Documents .....	1-3
The IBM 6400 Printer .....	1-5
Standard Capabilities .....	1-7
Host Computer Interfaces .....	1-7
Printer Emulations .....	1-7
Output Control .....	1-9
Graphics and Vertical Formatting .....	1-9
Built-in Diagnostic Tools .....	1-10
Optional Features .....	1-11
Protocols and Emulations .....	1-13

## **2 Setting Up the Printer**

Chapter Contents .....	2-1
Installation, Attachment and Configuration Overview .....	2-2
Before You Begin .....	2-4
Select a Site .....	2-5
Printer Component Locations .....	2-8
Removing Packing Material .....	2-12
Removing Shipping Restraints (Cabinet Models) .....	2-12
Remove the Cardboard Packing .....	2-13
Remove the Hammer Bank Protective Foam .....	2-14
Remove the Platen Protective Foam .....	2-15

Remove the Protective Film .....	2-16
Release the Paper Chains .....	2-17
Removing Shipping Restraints (Pedestal Models) .....	2-18
Remove the Protective Film .....	2-19
Remove the Hammer Bank Protective Foam .....	2-20
Remove the Platen Protective Foam .....	2-21
Attach the Input Paper Shelf and Output Basket .....	2-22
Connect the Interface and Power Cables (Cabinet Models) .....	2-23
Connect the Interface and Power Cables (Pedestal Models) .....	2-25
Attach the Operator Panel Overlay Label .....	2-27
Install the Ribbon .....	2-28
Load the Paper .....	2-35
Power On the Printer .....	2-43
Set the Top-of-Form .....	2-47
Test the Printer .....	2-50

### **3**    **Configuring the Printer**

Chapter Contents .....	3-1
Overview .....	3-2
The Configurations .....	3-2
Active versus Saved Configurations .....	3-3
The Configuration Main Menu .....	3-4
Using the Operator Panel .....	3-6
Program Mode .....	3-7
Unlocking the Program Mode .....	3-7
Locking the Program Mode .....	3-7
Printing the Current Configuration .....	3-8
Factory Default Configuration Values .....	3-11
Changing Parameters .....	3-18
Saving Your Configuration in a Custom Set .....	3-20
Loading Custom Sets or Factory Defaults .....	3-23
Changing the Power On Configuration .....	3-25

## 4 Configuration Menus

Chapter Contents . . . . .	4-1
Overview . . . . .	4-7
How to Read Configuration Menus . . . . .	4-7
The Configuration Main Menu . . . . .	4-9
Printer Control Menu . . . . .	4-10
Interface Selection . . . . .	4-11
Display Language . . . . .	4-11
Alarm Control . . . . .	4-11
Print Direction . . . . .	4-11
Hex Print Mode . . . . .	4-12
Power On State . . . . .	4-12
Paper Jam Detection . . . . .	4-12
Forms Speed . . . . .	4-12
Set Platen at Bottom of Form . . . . .	4-13
Shuttle Timeout . . . . .	4-13
Energy Saver Timer . . . . .	4-13
OCR B Font Density . . . . .	4-14
Eject/Restore . . . . .	4-14
Configuration Management Menu . . . . .	4-16
Recall Custom Set . . . . .	4-17
Save Current Values . . . . .	4-18
Delete Custom Set . . . . .	4-18
Change Power On Set . . . . .	4-18
Protect Custom Sets . . . . .	4-18
Print Custom Set Values . . . . .	4-18
Twinax Interface Menu . . . . .	4-19
Print Language . . . . .	4-21
Print Character Table . . . . .	4-21
Active Print Language . . . . .	4-21
Printer Emulation . . . . .	4-21
Printer Address . . . . .	4-22
World Trade (5225 Only) . . . . .	4-22

Cancel Buffers .....	4-22
Hex Transparent Control .....	4-23
Undefined Character Reporting .....	4-23
Undefined Character Substitution .....	4-23
Load Alternate Character Option .....	4-24
Print Text Direction .....	4-24
Override Host .....	4-24
Format Control .....	4-25
Hex Print Mode .....	4-25
Coax Interface Menu .....	4-26
Print Language .....	4-28
Print Character Table .....	4-28
Active Print Language .....	4-28
PA1 .....	4-28
PA2 .....	4-29
Buffer Reprint .....	4-29
Printer Emulation .....	4-29
Early Print Complete .....	4-29
Cancel Buffers .....	4-30
Hex Transparent Control .....	4-30
Mono/Dual Case .....	4-30
Print Text Direction .....	4-31
Image Buffer Size .....	4-31
Intervention Required .....	4-31
Translate Table .....	4-31
Override Host .....	4-32
Format Control .....	4-32
Hex Print Mode .....	4-32
Compatibility Options Menu (Coax Only) .....	4-33
Compatibility Option 1: Carriage Return at MPP+1 .....	4-34
Compatibility Option 2: New Line at MPP+1 .....	4-34
Compatibility Option 3: Position After Form Feed (4234 only) .....	4-34
Compatibility Option 4: Form Feed at End of Print Buffer .....	4-34
Compatibility Option 5: Null Supression .....	4-35



Compatibility Option 6: Form Feed Command Position . . . . .	4-35
Compatibility Option 7: Automatic Form Feed at End of Print Buffer . . . . .	4-35
Compatibility Option 8: Automatic FF After Operator-Initiated Copy . . . . .	4-36
Compatibility Option 9: CR, EM, and NL (3287 only) . . . . .	4-36
Compatibility Option 10: Bottom Margin (SCS data stream only) . . . .	4-36
Parallel Interface Menu . . . . .	4-37
Interface Type . . . . .	4-37
PC Parallel Menu . . . . .	4-38
Data Bit 8 . . . . .	4-39
Data Polarity . . . . .	4-39
Strobe Polarity . . . . .	4-39
Response Polarity . . . . .	4-39
Busy on Strobe . . . . .	4-39
Latch Data On . . . . .	4-40
Prime Signal . . . . .	4-40
TOF Action at Prime Signal . . . . .	4-40
Buffer Size in Kilobytes . . . . .	4-40
Dataproducts Menu . . . . .	4-41
Data Bit 8 . . . . .	4-42
PI Ignored . . . . .	4-42
Data Polarity . . . . .	4-42
Data Request Polarity . . . . .	4-42
Strobe Polarity . . . . .	4-42
IEEE 1284 . . . . .	4-43
Serial Interface Menu . . . . .	4-44
Interface Type . . . . .	4-45
Data Protocol . . . . .	4-45
Baud Rate . . . . .	4-45
Data Bits . . . . .	4-46
Stop Bits . . . . .	4-46
Parity . . . . .	4-46
Data Terminal Ready . . . . .	4-46

Request to Send .....	4-47
Buffer Size in Kilobytes .....	4-47
Emulation Configuration Menu .....	4-49
ASCII Printer Emulation .....	4-50
Printer Emulation Configuration .....	4-51
Print Format .....	4-51
Proprinter III XL Emulation Menu .....	4-52
Print Language .....	4-53
Alternate Character Set .....	4-53
Define CR Code .....	4-53
Auto LF .....	4-53
Define LF Code .....	4-54
FF Valid at TOF .....	4-54
20 CPI Condensed .....	4-54
Epson Emulation Menu .....	4-55
Character Sets .....	4-56
Epson Print Language .....	4-56
Define CR Code .....	4-56
Auto LF .....	4-56
Define LF Code .....	4-57
Printer Select .....	4-57
20 CPI Condensed .....	4-57
P-Series Emulation Menu .....	4-58
Character Sets .....	4-60
Print Language .....	4-60
Control Code 06 .....	4-61
Control Code 08 .....	4-61
Define CR Code .....	4-61
Auto LF .....	4-61
Overstrike .....	4-62
Define LF Code .....	4-62
Select SFCC .....	4-62
EVFU Select .....	4-62
Alternate Set 80-9F .....	4-63

P-Series XQ Emulation Menu .....	4-64
Control Code 06 .....	4-65
Define CR Code .....	4-65
Auto LF .....	4-65
Define LF Code .....	4-65
Compressed Print .....	4-66
Elong./Alt. Font .....	4-66
High Speed Print Mode .....	4-66
EVFU Select .....	4-66
Upper Case Select .....	4-67
Slew Relative .....	4-67
Serial Matrix Emulation Menu .....	4-68
Character Sets .....	4-70
Print Language .....	4-70
Control Code 06 .....	4-71
Define CR Code .....	4-71
Auto LF .....	4-71
Overstrike .....	4-71
Define LF Code .....	4-72
Printer Select .....	4-72
Alternate Select 80-9F .....	4-72
Print Format Menu .....	4-73
Characters Per Inch .....	4-74
Lines Per Inch .....	4-74
Forms Width .....	4-75
Forms Length .....	4-77
Print Quality .....	4-78
Print Character Table .....	4-78
Print Attributes .....	4-79
Margins .....	4-79
Perforation Skip .....	4-80
Reset Cmd .....	4-80
Operator Print Tests Menu .....	4-81
Printer Information Menu .....	4-82

RibbonMinder .....	4-83
New Ribbon .....	4-83
Ribbon Action .....	4-83
Ribbon Size .....	4-84
Ribbon Adjust .....	4-84

## **5 Printer Interfaces**

Chapter Contents .....	5-1
Overview .....	5-2
RS-232 and RS-422 Serial Interfaces .....	5-3
RS-232 and RS-422 Serial Interface Signals .....	5-4
RS-232 Serial Interface Protocols .....	5-5
RS-232 and RS-422 Serial Interface Protocols .....	5-5
RS-232 and RS-422 Serial Interface Error Handling .....	5-5
RS-232 and RS-422 Serial Interface Configuration .....	5-6
PC Parallel Interface .....	5-7
PC Parallel Interface Signals .....	5-8
PC Parallel Interface Configuration .....	5-9
Dataproducts Parallel Interface .....	5-10
Dataproducts Parallel Interface Signals .....	5-11
Dataproducts Parallel Interface Configuration .....	5-12
IEEE 1284 Parallel Interface .....	5-13
Operating Modes .....	5-13
The Negotiation Phase .....	5-14
Signals .....	5-14
Terminating Resistor Configurations .....	5-17

## **6 Routine Service and Diagnostics**

Chapter Contents .....	6-1
Overview .....	6-2
Cleaning Requirements .....	6-2
Cleaning the Outside of the Cabinet .....	6-2

Cleaning Inside the Cabinet .....	6-3
Printer Self-Tests .....	6-7
Running the Printer Self-Tests .....	6-8
Hex Code Printout .....	6-10
Fault Messages .....	6-14

## **7 RibbonMinder™**

Chapter Contents .....	7-1
Overview .....	7-2
Configuring the RibbonMinder .....	7-3
Running a Job .....	7-5
New Ribbon .....	7-5
Ribbon Action .....	7-5
Ribbon Size .....	7-6
Ribbon Adjust .....	7-6
Fault Action .....	7-7

## **Appendices**

A: Printer Specifications .....	A-1
B: A Quick Look at Line Matrix Printing .....	B-1
C: Host Attachment .....	C-1
D: Code V, IGP, and IPDS Menus .....	D-1

## **Glossary**

## **Index**

---

## Energy Star



The Environmental Protection Agency ENERGY STAR Computers program is a partnership effort with manufacturers of data processing equipment to promote the introduction of energy-efficient personal computers, monitors, printers, fax machines, and copiers to help reduce air pollution and global warming caused by electricity generation.

IBM Printing Systems Company participates in this program by introducing printers that reduce power consumption when they are not being used. As an Energy Star Partner, IBM Printing Systems Company has determined that this product meets the Energy Star guidelines for energy efficiency.

**Note:** The Energy Star emblem does not represent EPA endorsement of any product or service.

---

## Notices

References in this publication to IBM products, programs, or services do not imply that IBM intends to make these available in all countries in which IBM operates. Any reference to an IBM licensed product, program, or service is not intended to state or imply that only IBM's product, program, or service may be used. Any functionally equivalent product, program, or service that does not infringe any of IBM's intellectual property rights may be used instead of the IBM product. Evaluation and verification of operation in conjunction with other products, except those expressly designated by IBM, is the user's responsibility.

Any performance data contained in this document was obtained in a controlled environment based on the use of specific data. The results that may be obtained in other operating environments may vary significantly. Users of this document should verify the applicable data in their specific environment. Therefore, such data does not constitute a performance guarantee or warranty.

IBM may have patents or pending patent applications covering subject matter in this document. The furnishing of this document does not give you any license to these patents. You can send license inquiries, in writing, to the IBM Corporation, IBM Director of Licensing, 208 Harbor Drive, Stamford, Connecticut, United States, 06904.

---

## Communication Notices

**Federal Communications Commission (FCC) Statement:** This equipment has been tested and found to comply with the limits for a Class A digital device, pursuant to Part 15 of the FCC Rules. These limits are designed to provide reasonable protection against harmful interference when the equipment is operated in a commercial environment. This equipment generates, uses, and can radiate radio frequency energy and, if not installed and used in accordance with the instruction manual, may cause harmful interference to radio communications. Operation of this equipment in a residential area is likely to cause harmful interference, in which case the user will be required to correct the interference at his own expense.

Properly shielded and grounded cables and connectors must be used in order to meet FCC emission limits. IBM is not responsible for any radio or television interference caused by using other than recommended cables and connectors or by unauthorized changes or modifications to this equipment. Unauthorized changes or modifications could void the user's authority to operate the equipment.

This device complies with Part 15 of the FCC Rules. Operation is subject to the following two conditions: (1) this device may not cause harmful interference, and (2) this device must accept any interference received, including interference that may cause undesired operation.

**Canadian Department of Communications Compliance Statement:** This Class A digital apparatus meets the requirements of the Canadian Interference-Causing Equipment Regulations.

**Avis de conformité aux normes du ministère des Communications du Canada:** Cet appareil numérique de la classe A respecte toutes les exigences du Règlement sur le matériel brouilleur du Canada.

**The United Kingdom Telecommunications Statement of Compliance:** This apparatus is approved under the approval No. NS/G/1234/J/100003 for the indirect connections to the public telecommunications systems in the United Kingdom.

**New Zealand:** Warning – This is a Class A product. In a domestic environment this product may cause radio interference in which case the user may be require to take adequate measure.

**Japanese VCCI:**

**注意**

この装置は、情報処理装置等電波障害自主規制協議会（VCCI）の基準に基づく第一種情報技術装置です。この装置を家庭環境で使用すると電波妨害を引き起こすことがあります。この場合には使用者が適切な対策を講ずるよう要求されることがあります。

**European Union (EC) Electromagnetic Compatibility Directives:** This product is in conformity with the protection requirements of EC Council Directive 89/336/EEC on the approximation of the laws of the Member States relating to electromagnetic compatibility. IBM cannot accept responsibility for any failure to satisfy the protection requirements resulting from a non-recommended modification of the product, including the fitting of non-IBM option cards.

Dieses Gerät ist berechtigt in Übereinstimmung mit dem deutschen EMVG vom 9.Nov.92 das EG-Konformitätszeichen zu führen.

Properly shielded and grounded cables and connectors must be used in order to reduce the potential for causing interference to radio and TV communication and to other electrical or electronic equipment. Such cables and connectors are available from IBM authorized dealers. IBM cannot be responsible for any interference caused by using other than recommended cables and connectors.

This product has been tested and found to comply with limits for Class A Information Technology Equipment according to CISPR 22/European Standard EN 55022. The limits for Class A equipment were derived for commercial and industrial environments to provide reasonable protection against interference with licensed communication equipment.

Warning: This is a Class A product. In a domestic environment this product may cause radio interference in which case the user may be required to take adequate measures.

Dieses Gerät erfüllt die Bedingungen der EN 55022 Klasse A. Für diese Klasse von Geräten gilt folgende Bestimmung nach dem EMVG:

Geräte dürfen an Orten, für die sie nicht ausreichend entstört sind, nur mit besonderer Genehmigung des Bundesministers für Post und Telekommunikation oder des Bundesamtes für Post und Telekommunikation betrieben werden. Die Genehmigung wird erteilt, wenn keine elektromagnetischen Störungen zu erwarten sind.

(Auszug aus dem EMVG vom 9.Nov.92, Para.3, Abs.4)

Hinweis: Dieses Genehmigungsverfahren ist von der Deutschen Bundespost noch nicht veröffentlicht worden.



---

## Electrical Safety

This printer is inspected and listed by recognized national testing laboratories, such as Underwriters Laboratories, Inc. (UL) in the U.S.A. and Canadian Standards Association (CSA) in Canada. Listing of a product by a national testing laboratory indicates that the product is designed and manufactured in accordance with national requirements intended to minimize safety hazards. IBM equipment meets a very high standard of safety in design and manufacture. Remember, however, that this product operates under conditions of high electrical potentials and heat generation, both of which are functionally necessary.

---

## Trademarks and Service Marks

The following terms, denoted by an asterisk (\*) in this publication, are trademarks of the IBM Corporation in the United States or other countries or both.

IBM  
IPDS  
Proprinter  
AS/400  
OS/2

The following terms, denoted by a double asterisk (\*\*) in this publication, are trademarks of other companies:

Code V	QMS, Inc.
DEC	Digital Equipment Corporation
Dataproducts	Dataproducts, Inc.
Energy Star	United States Environmental Protection Agency
Epson	Epson Seiko Corporation
FX	Epson Seiko Corporation
IGP	Printronix, Inc.
MS-DOS	Microsoft Corporation
Printronix	Printronix, Inc.
QMS	QMS, Inc.
Windows	Microsoft Corporation

---

## Safety Notices

### DANGER

To prevent possible injury, do not connect the AC power source before removing the shipping restraints. If the power source has already been connected, disconnect it before performing the shipping restraint removal procedures.

### DANGER

To prevent serious personal injury from electrical shock when connecting or disconnecting the signal cable, power off the printer and unplug the power cable.

### DANGER

Disconnect the AC power cord before cleaning the printer.

## Sikkerhedsinstruktioner

### FARE

For at forebygge skader må der ikke tilsluttes strøm førend alle forsendelsesblokeringer er fjernede. Hvis strømmen allerede er sluttet til, afbryd da forbindelsen før De begynder at tage forsendelsesblokeringerne ud.

### FARE

Hver gang De vil sætte ledningen, der forbinder computeren og printeren, i eller tage den ud, skal De først slukke for printeren og tage stikket ud af stikkontakten for at forebygge alvorlig personskade der forvoldes af elektriske stød.

### FARE

Tag stikket ud af kontakten inden De gør printeren ren.

## **Huomautuksia Turvallisuudesta**

### **VAARA**

**Mahdollisen vahingon välttämiseksi vaihtovirtaa ei pidä kytkeä ennen pakkaustarvikkeiden poistamista. Jos virtalähde on jo kytkettynä, katkaise virta ennen pakkaustarvikkeiden poistamista.**

### **VAARA**

**Sähköisku voi aiheuttaa vakavia henkilövahinkoja. Tästä syystä täytyy kirjoittimesta aina katkaista virta ja irrottaa virtakaapeli, kun signaalikaapeli liitetään tai irrotetaan.**

### **VAARA**

**Irrota vaihtovirtajohto ennen kirjoittimen puhdistusta.**

## **Normas de Segurança**

### **PERIGO**

**A fim de evitar ferimentos, não ligue a tomada de corrente alternada antes de remover as fitas de restrição usadas para o envio da impressora. Se a tomada já tiver sido ligada, desligue-a antes de remover as fitas de restrição.**

### **PERIGO**

**Quando ligar ou desligar o cabo de sinal, a fim de evitar ferimentos graves devido a choque eléctrico, desligue sempre a impressora e remova o cabo de energia da tomada.**

### **PERIGO**

**Desligue o fio de corrente alternada antes de limpar a impressora.**

## Säkerhetsföreskrifter

### FARA

Undvik skaderisker genom att inte ansluta nätspänningskällan innan du tagit bort transportskydden. Om nätspänningskällan redan anslutits ska den kopplas loss innan du tar bort transportskydden.

### FARA

Undvik allvarliga personskador från elektriska stötar när du ansluter eller kopplar loss signalkablen, genom att stänga av strömmen till skrivaren och koppla loss nätkabeln.

### FARA

Koppla loss nätkabeln innan du rengör skrivaren.

## Sikkerhetsinformasjon

### ADVARSEL

For å unngå eventuelle skader må skriveren ikke knyttes til lysnettet før transportsikringen er fjernet. Hvis den allerede er knyttet til lysnettet, må den frakoples før transportsikringen fjernes.

### ADVARSEL

Slå av skriveren og trekk ut strømledningens støpsel fra stikkontakten når du skal koble signalkabelen til eller fra, slik at alvorlige personskader unngås som følge av elektrisk støt.

### ADVARSEL

Trekk ut strømledningens støpsel fra stikkontakten før skriveren rengjøres.

## 安全上の注意点

### 危険

ケガをしないために、輸送用の止め具を取り外してから、AC電源ケーブルを接続してください。電源からプラグを外してください。

### 危険

感電しないよう、シグナルケーブルを接続、または取りはずす際は、必ずプリンタの電源を切り、電源コードを抜いてください。

### 危険

プリンタを清掃する前に、AC電源ケーブルを抜いてください。



# 1

## Introduction

### Chapter Contents

---

About This Setup Guide .....	1-2
How to Locate Information .....	1-2
Notes and Notices .....	1-2
Format Conventions .....	1-3
Related Documents .....	1-3
The IBM 6400 Printer .....	1-5
Standard Capabilities .....	1-7
Host Computer Interfaces .....	1-7
Printer Emulations .....	1-7
Output Control .....	1-9
Graphics and Vertical Formatting .....	1-9
Built-in Diagnostic Tools .....	1-10
Optional Features .....	1-11
Protocols and Emulations .....	1-13

## About This Setup Guide

---

This *Setup Guide* is designed so that you can quickly install and configure your IBM 6400 printer.

### How to Locate Information

You can locate information in four ways:

- Use the **Table of Contents** at the front of the manual.
- Use the **Chapter Contents** listed at the front of each chapter.
- Use the **Index** at the back of the manual.
- Use the **Glossary** to understand the printer terms and acronyms in this *Setup Guide*.

### Notes and Notices

For your safety and to protect valuable equipment, it is very important that you read and comply with the notes and notices included in this manual. Danger, Caution, and Warning notices are numbered. These numbers enable you to find translated versions of these notices in the IBM 6400 Line Matrix Printer Safety Notices booklet. Descriptions for each type of notice follow:

#### **DANGER**

**A danger notice calls attention to a situation that is potentially lethal or extremely hazardous to people.**

#### **CAUTION**

**A caution notice calls attention to a situation that is extremely hazardous to people because of some existing condition.**

#### **WARNING**

**A warning notice indicates the possibility of damage to a program, device, system, or data.**

#### **IMPORTANT**

**Important draws your attention to information vital to proper operation of the printer.**

**NOTE:** A note gives you helpful tips about printer operation.



## Format Conventions

Key names, indicator names, and messages that appear on the operator panel display are capitalized as they actually appear on the printer. Key names are shown in bold. For example:

Press the **Start** key. The Attention indicator will light.

## Related Documents

For more information about your printer, refer to the following documents:

- *IBM 6400 Line Matrix Printer Operator's Guide* (S246-0115) — Includes step-by-step instructions on daily printer operations. IBM form numbers for the various language versions of this book are as follows:
- *IBM 6400 Line Matrix Printer Safety Notices* (G544-5389) — Provides translated safety notices.
- *IBM Network Print Server Ethernet Administrator's Guide* (S246-0111) — Describes how to install and submit print jobs using this device on networks using ethernet communication protocols.
- *IBM Network Print Server Token-Ring Administrator's Guide* (S246-0112) — Describes how to install and submit print jobs using this device on networks using token-ring communication protocols.
- *IBM 6400 Line Matrix Printer Maintenance Information Manual* (S246-0117) — Explains how to maintain and repair the 6400 line matrix printer at the field service level of maintenance. This manual covers alignments and adjustments, preventive and corrective maintenance, troubleshooting, and basic principles of operation.
- *IBM 6400 ASCII Programmer's Reference Manual* (S246-0118) — Provides descriptions of ASCII printer codes and character sets.
- *IBM 6400 Coax/Twinax Programmer's Reference Manual* (S246-0147) — Provides descriptions of coax and twinax printer control codes and character sets.
- *IBM 6400 IPDS Programmer's Reference Manual* (S246-0148) — Provides information used with the IPDS\* emulation enhancement feature.
- *Coax/Twinax Multi-Platform Interface Option Installation and Operation Guide* (S246-0149) — Describes how to install and use this feature to support coax/twinax attachment to host systems.

- *IBM 6400 Code V User's Manual* (S246-0150) — Provides information used with the optional Code V\*\* Printronix\*\* emulation enhancement feature. The Code V Printronix emulation allows you to create and store forms; generate logos, bar codes, and expanded characters; create other graphics, and merge graphics with alphanumeric data as a document is printed. This emulation is based on the Quality MicroSystems, Inc., graphics language.
- *IBM 6400 IGP\*\* User's Manual* (S246-0151) — Provides information used with the optional IGP Printronix emulation enhancement feature. The IGP Printronix emulation allows you to create and store forms; generate logos, bar codes, and expanded characters; create other graphics, and merge graphics with alphanumeric data as a document is printed.

## The IBM 6400 Printer

---

The IBM 6400 printers offer software versatility and the latest refinements in line matrix printing technology.

Most line printers have specialized architectures that enable them to emulate (behave like) another printer. Your IBM printer, however, introduces an open architecture in which numerous emulations may be selected from the operator panel.

Proprinter\* III XL, Epson\*\* FX, P-Series, P-Series XQ, and Serial Matrix are the standard emulations. Coax and Twinax are offered as interface features. IPDS, Code V, and IGP are offered as optional emulation features. To load all of the configuration parameters (forms length, line spacing, etc.), simply power on the printer.

You can easily switch to any of the optional emulations by using the recall custom set feature from the operator panel. You can also switch emulations by using the operator panel menu keys.

No matter what emulation is installed, your printer is very easy to use. The message display and lights on the operator panel communicate with you clearly and directly. You can select every function on your printer at the operator panel or you can send commands from the host computer.

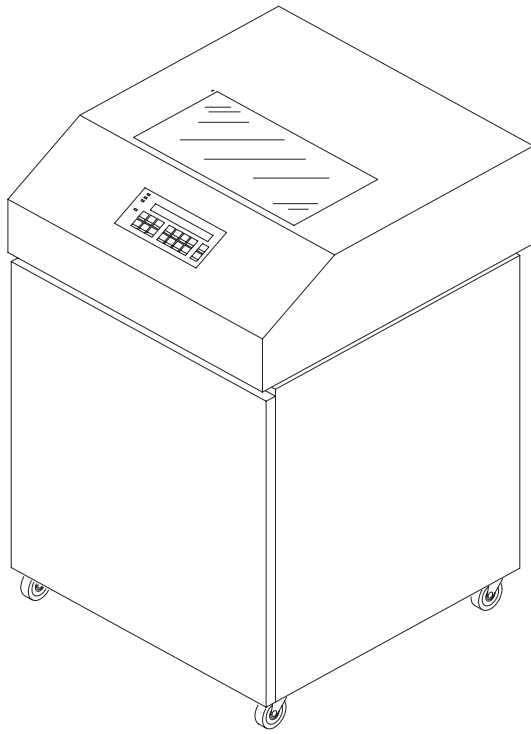

Cabinet Models

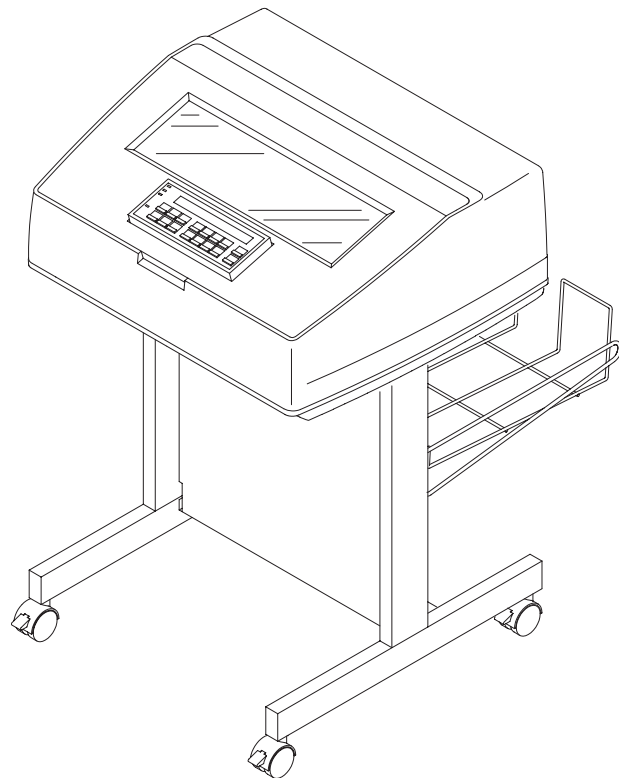

Pedestal Models

**Figure 1-1. The IBM 6400 Line Matrix Printer**

## Standard Capabilities

---

The 6400 has the following general characteristics:

- A broad range of print speeds in both cabinet and pedestal models
- Supports similar features across the entire product line to allow maximum flexibility in matching the printer to the requirements
- Energy Star\*\* compliant

The following sections summarize the standard capabilities of the IBM 6400 printer.

### Host Computer Interfaces

The following host computer interface choices are available:

- RS-232 Serial
- RS-422 Serial
- PC Parallel
- DataProducts Parallel
- IEEE 1284

**NOTE:** Two Coax/Twinax features are available with this printer:

1. IBM Coax/Twinax feature
2. Coax/Twinax Multi-Platform Interface feature.

These features are described in Optional Features

### Printer Emulations

Each emulation provides a different set of configuration menus, control codes, and character sets. The following printer emulations (or protocols) are standard, and selectable at the operator panel:

- Proprinter III XL Emulation
- Epson FX Emulation
- Printronix P-Series Printer Emulation
- Printronix P-Series XQ Variant Printer Emulation
- Printronix Serial Matrix Printer Emulation

### **Proprinter III XL and Epson FX Emulations**

The Proprinter III XL and Epson FX emulations are industry-standard printer emulations.

### **Printronix P-Series Printer Emulation**

This code system was developed especially for Printronix line matrix printers. As line matrix printers became more sophisticated, this code system kept pace by adding codes that fully exploit line matrix printer capabilities.

#### **IMPORTANT**

**Appears as “P-Series” on the operator panel.**

### **Printronix P-Series XQ Variant Printer Emulation**

This code system was devised for a series of Printronix printers manufactured between 1974 and 1991, that are no longer available. It enables the printer to emulate Printronix P300 and P600 printers.

#### **IMPORTANT**

**Appears as “P-Series XQ” on the operator panel.**

### **Printronix Serial Matrix Printer Emulation**

This printer emulation is very similar to the code system used by an IBM Graphics Printer, but it contains more features. This emulation enables a Printronix line matrix printer to print files coded for a serial matrix printer, and is sometimes referred to as the Serial Matrix emulation.

#### **IMPORTANT**

**Appears as “Serial Matrix” on the operator panel.**

**NOTE:** *Serial matrix* refers to the way printer characters are formed: A moving printhead uses pins to form whole characters one at a time and one after the other. The pins print dots according to programmed matrix patterns. Data is sent to the printer through either a serial or a parallel interface, but the *printhead* must receive the data serially in order to form each character.

A Printronix line matrix printer also forms characters with dots in matrix patterns, but it feeds print data in parallel to many hammers mounted on a rapidly oscillating shuttle. The hammers fire simultaneously to print entire lines at a time.

## Output Control

The printers have the following output control features:

- Six modes for printing text:
  - 1) Near-Letter Quality (NLQ)
  - 2) Near-Letter Quality Sans Serif
  - 3) Data Processing (DP)
  - 4) Draft
  - 5) Optical Character Recognition Font A (OCR A)
  - 6) Optical Character Recognition Font B (OCR B)

OCR A and OCR B support 120 and 180 PEL, with 120 PEL the default value.

- Selectable forms length and width
- Character attribute specification:
  - 1) Selectable pitch: normal, expanded, and compressed
  - 2) Emphasized (shadow) printing
  - 3) Automatic underlining and overscoring
  - 4) Superscript and subscript printing
  - 5) Double high and wide printing
- Resident multinational character sets

## Graphics and Vertical Formatting

Several graphics and vertical formatting features are available:

- Three built-in graphics generators:
  - 1) IBM Proprinter III XL bit-image graphics
  - 2) Epson FX dot graphics mode
  - 3) Printronix P-Series Plot
- Programmable electronic vertical formatting provides rapid vertical paper movement to specified lines for printing repetitive and continuous forms. You can use the following methods:
  - 1) Vertical tabbing in Serial Matrix, Proprinter III XL, and Epson FX emulation modes
  - 2) Electronic Vertical Format Unit (EVFU) in P-Series emulation mode

## **Built-in Diagnostic Tools**

The following diagnostic tools are provided with the printer:

- Comprehensive diagnostic self-tests permanently stored in the printer
- Configuration printout
- Data stream hex code printout



## Optional Features

---

The following features can be ordered and installed on this printer. If you ordered a feature at the time of purchase, the feature may already be installed on your printer. Refer to the documentation shipped with the feature for more details.

For detailed information about these features or for information on ordering a feature, contact your IBM sales representative or IBM Authorized Remarketeer.

- **IBM Coax/Twinax Attachment:**  
Enables you to attach this printer to IBM host systems, such as an AS/400 or S/390. This feature also helps you to replace IBM coax/twinax printers such as the IBM 3262 Models 3 and 13 printer and IBM 5224 Models 1 and 2. This feature can be used with the Intelligent Printer Data Stream (IPDS) feature which is described below.
- **Multi-Platform Interface (MPI) Coax/Twinax Attachment:**  
Enables you to replace many non-IBM printers that are coax or twinax-compatible attached to various IBM systems. This feature also enables you to attach this printer using both the parallel and coax/twinax ports. Then, you can submit print jobs using parallel and either coax or twinax communication protocols. (You must send print jobs using either coax or twinax, but not both.)
- **IBM Intelligent Printer DataStream Coax/Twinax:**  
Provides ability to create forms, overlays, and graphics. IPDS also provides compatibility when replacing printers such as the IBM 4234 Models 7 and 11. This feature also supports many versions of the Print Services Facility (PSF). This feature requires the IBM Coax/Twinax Attachment.

- **Code V:**  
 This is an implementation of the Printronix Intelligent Graphics Processor architecture and is used commonly to create graphics for optical character recognition and bar codes. This feature is also designed for those applications which use the Quality Micro Systems, Inc. graphics language, which is often referred to as the QMS Code V Magnum emulation and those applications that use the Printronix Code V Graphics Language, which is often referred to as VGL.  
 This feature can co-exist with the IBM Intelligent Printer Data Stream feature, and/or with either coax/twinax feature, or can be used on the ASCII models.
- **IGP:**  
 This is an implementation of Intelligent Graphics Processor architecture and is used commonly to create graphics for optical character recognition and bar codes. This feature is also designed for those applications which use the Printronix Graphics Language, which is often referred to as PGL.  
 This feature can co-exist with the IBM Intelligent Printer Data Stream feature, and/or with either coax/twinax feature, or can be used on the ASCII models.
- **Network Print Server:**  
 Enables you to attach your printer to Local Area Networks using token-ring or ethernet protocols. The Network Print Server functions as a workstation server on your network, enabling your users to submit print jobs to your printer.  
 The Network Print Server provides multiple network protocol support that allows you to submit print jobs from Novell Netware, IBM LAN Server, IBM AIX, and other TCP/IP networks.
- **Dataproducts Adapter:**  
 Supplies a 50 pin AMP Amplitude HDH-20 data cable connector. This feature is necessary if you are using the Dataproducts parallel protocol.
- **Input Paper Shelf:**  
 Pedestal model only. Provides a shelf to hold a box of paper or forms. This is a convenient feature if you need to move the printer often.

## Protocols and Emulations

---

A *protocol* is a set of rules governing the exchange of information between the printer and its host computer. These rules consist of codes that manipulate and print data and allow for machine-to-machine communication. A printer and its host computer must use the same protocol. As used in this manual, *protocol* and *emulation* mean the same thing.

Most impact printers use single ASCII character codes to print text, numbers, and punctuation marks. Some characters, both singly and in groups of two or more, are defined as control codes. Control codes instruct the printer to perform specific functions, such as underlining text, printing subscripts, setting page margins, etc. The main difference between most printer protocols is in the characters used to create control codes and the ways in which these characters are formatted.

When the printer executes the character and control codes of a particular printer protocol, it is “emulating” that printer. If the printer uses the Proprinter III XL protocol, for example, it is emulating an IBM Proprinter III XL printer. If the printer is using the Epson FX printer protocol, for example, we can also say it is in Epson FX emulation mode.

There are additional emulations that are provided as optional features, such as the IGP and Code V emulations. For additional information, refer to Appendix D and the related documents listed in the section that begins on page 1–3.



# 2 Setting Up the Printer

## Chapter Contents

---

Installation, Attachment and Configuration Overview . . . . .	2-2
Before You Begin . . . . .	2-4
Select a Site . . . . .	2-5
Printer Component Locations . . . . .	2-8
Removing Packing Material . . . . .	2-12
Removing Shipping Restraints (Cabinet Models) . . . . .	2-12
Remove the Cardboard Packing . . . . .	2-13
Remove the Hammer Bank Protective Foam . . . . .	2-14
Remove the Platen Protective Foam . . . . .	2-15
Remove the Protective Film . . . . .	2-16
Release the Paper Chains . . . . .	2-17
Removing Shipping Restraints (Pedestal Models) . . . . .	2-18
Remove the Protective Film . . . . .	2-19
Remove the Hammer Bank Protective Foam . . . . .	2-20
Remove the Platen Protective Foam . . . . .	2-21
Attach the Input Paper Shelf and Output Basket . . . . .	2-22
Connect the Interface and Power Cables (Cabinet Models) . . . . .	2-23
Connect the Interface and Power Cables (Pedestal Models) . . . . .	2-25
Attach the Operator Panel Overlay Label . . . . .	2-27
Install the Ribbon . . . . .	2-28
Load the Paper . . . . .	2-35
Power On the Printer . . . . .	2-43
Set the Top-of-Form . . . . .	2-47
Test the Printer . . . . .	2-50

## Installation, Attachment, and Configuration Overview

---

The following is an overview of the steps you need to complete to successfully install, attach, and configure your printer:

1. Unpack the printer from the shipping package. Follow the instructions provided on the shipping package.
2. Set up the printer, which includes removing shipping materials, installing a ribbon, and loading paper. Follow the instructions in Chapter 2, “Setting Up the Printer.”
3. Perform an initial print test by printing the current configuration page as described in Chapter 3, “Configuring the Printer.”
4. Review the information contained in the *README.IST* file on the Configuration Utility diskette.

**NOTE:** The Configuration Utility diskette contains a *README.IST* file that describes the contents of the diskette, AIX print drivers, and configuration information for replacing existing Printronix printers. In addition, there might be another file, called *README.TXT* that contains information that was added after the printer documentation was printed.

5. Attach the printer to the host system and configure the host system to work with the printer.
  - a. For ASCII attachments, follow the instructions in the *6400 ASCII Programmer's Reference Manual*.
  - b. For Coax/Twinax attachments, follow the instructions in either the *6400 Coax/Twinax Programmer's Reference Manual* or the *Coax/Twinax Multi-Platform Interface Option Installation and Operation Guide*.
  - c. If you have ordered the Network Print Server feature, then for Ethernet or Token-Ring attachments, follow the instructions in either the *Network Print Server Ethernet Administrator's Guide* or the *Network Print Server Token-Ring Administrator's Guide*.

**NOTE:** If you are attaching this printer to an AIX host system, use the AIX Version 3.2.5 and 4.1 print drivers provided on the Printer Utility diskette.

6. If you have not already ordered a communications cable, see page A-9 for information on ordering a communications cable.
7. Configure the printer to work with host systems and to match your datastream, such as IBM Proprinter III XL. Follow the instructions provided in Chapter 3, “Configuring the Printer,” and review the information provided in Appendix C, “Host Attachment.”

**NOTE:** If you are replacing a Printronix printer, such as a P300, with this printer, make sure you review the information on the Configuration Utility diskette. The Configuration Utility diskette contains information that will help you configure this printer to match the configuration of the printer you are replacing.

8. Install and/or configure optional features by following instructions provided in the appropriate feature manual. Also, review Appendix D, “Optional Features,” for a brief description of the configuration information for the Code V, IGP, and IPDS optional features.

**NOTE:** For more detailed information about any optional feature, refer to the manual that was shipped with the feature. If you want to order a manual to learn more about these features, see the “Related Documents” section that begins on page 1-3.

## Before You Begin

---

Read this chapter carefully before installing and operating the IBM 6400 printer.

The printer is easy to install, but for your safety and to protect valuable equipment, perform all the procedures in this chapter in the order presented.

### **IMPORTANT**

**Make sure you have a way to move the printer and shipping pallet. You will need a pallet jack.**

**Make sure two people are available to unload the printer from the shipping pallet. (The shipping weight of a cabinet model printer is 285 pounds or 129.3 kilograms. The shipping weight of a pedestal model printer is 160 pounds or 72.6 kilograms.)**

**Make sure you have adequate room to maneuver the shipping pallet and printer to the location where you plan to install the printer.**



## Select a Site

---

Select a printer site that meets the following requirements:

- Cabinet models: Permits complete opening of the printer cover and both doors of the floor cabinet. See dimension requirements in Figure 2–1 on page 2–6.
- Pedestal models: Permits complete opening of the printer cover and good access to the paper areas at the front and rear of the printer. See dimension requirements in Figure 2–2 on page 2–7. In addition, the location for the pedestal models must be able to handle the acoustics level of the printer.
- Has a power outlet that supplies 100 to 120 Volts AC or 200 to 240 Volts AC at 47 to 63 Hz. (The printer automatically senses and adjusts itself to conform to the correct voltage range.) For more information, see the input voltage characteristics in Appendix A, *Printer Specifications*.
- Is relatively dust-free.
- Has a temperature range of 10° C to 40° C (50° F to 104° F), and a relative humidity from 10% to 90% (noncondensing).
- Is located within the maximum allowable distance to the host computer. This distance depends on the type of interface you plan to use, as shown in the following table:

Type of Interface	Maximum Distance to Host	
PC Parallel (See Note below)	5 meters	(15 feet)
IEEE 1284 Parallel (See Note below)	5 meters	(15 feet)
Dataproducts	12 meters	(40 feet)
Serial RS–232	15 meters	(50 feet)
Serial RS–422	120 meters	(400 feet)
Twinax (shielded cable) Twisted Pair / Type 3	1500 meters 300 meters	(4920 feet) (985 feet)
Coax	1500 meters	(4920 feet)

**NOTE:** For more reliable data transfers, a maximum of six feet is recommended for parallel cable length.

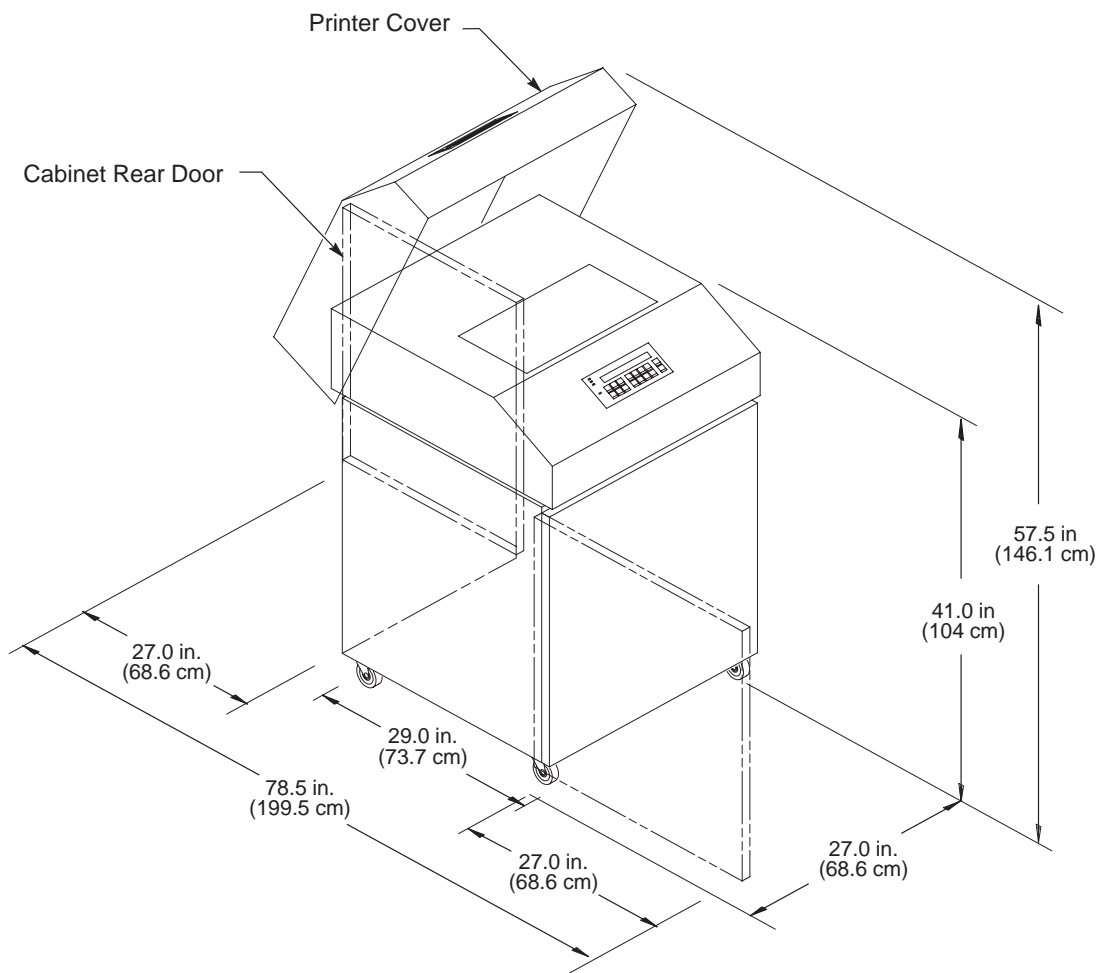

**Figure 2-1. Cabinet Model Printer Dimensions**

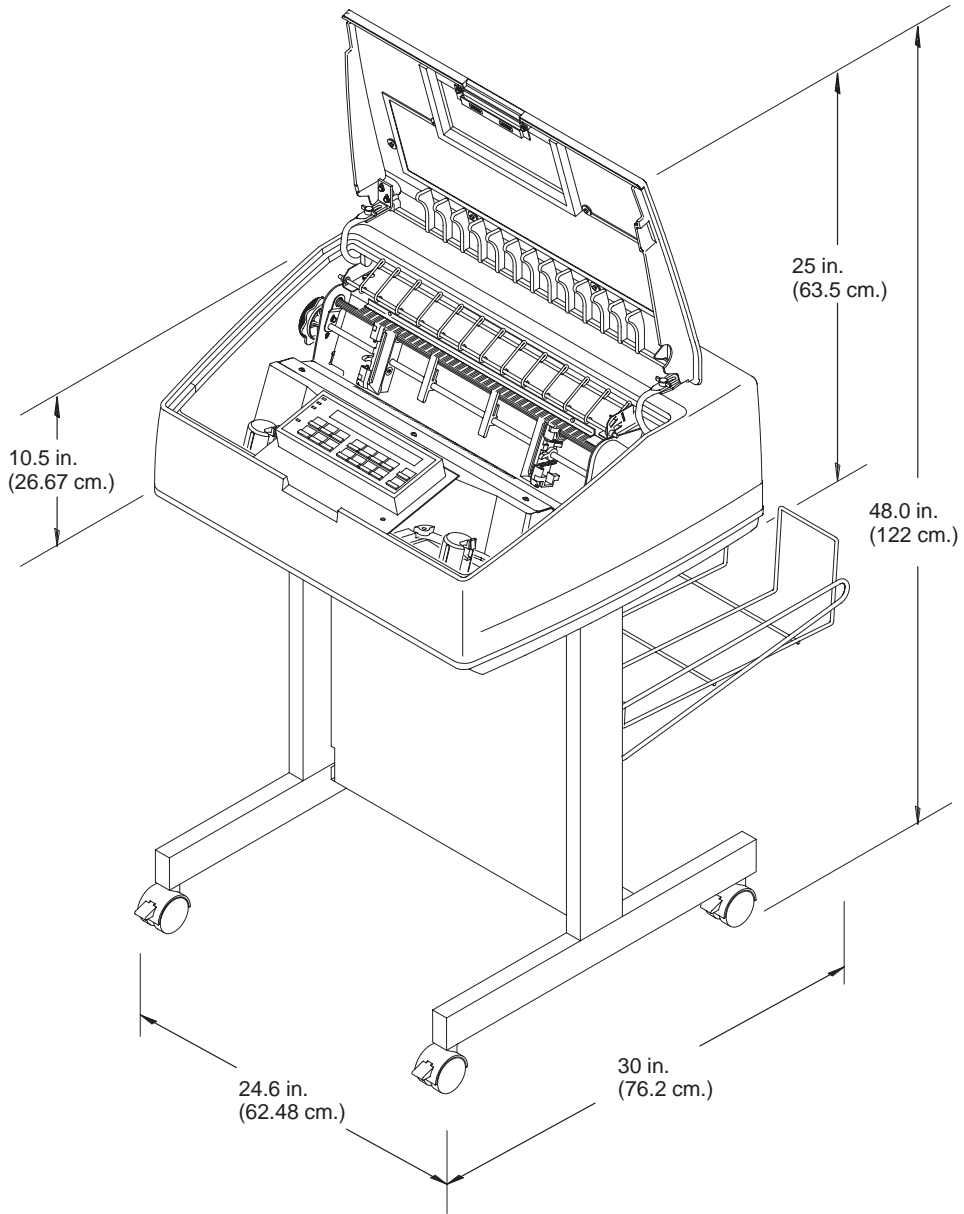
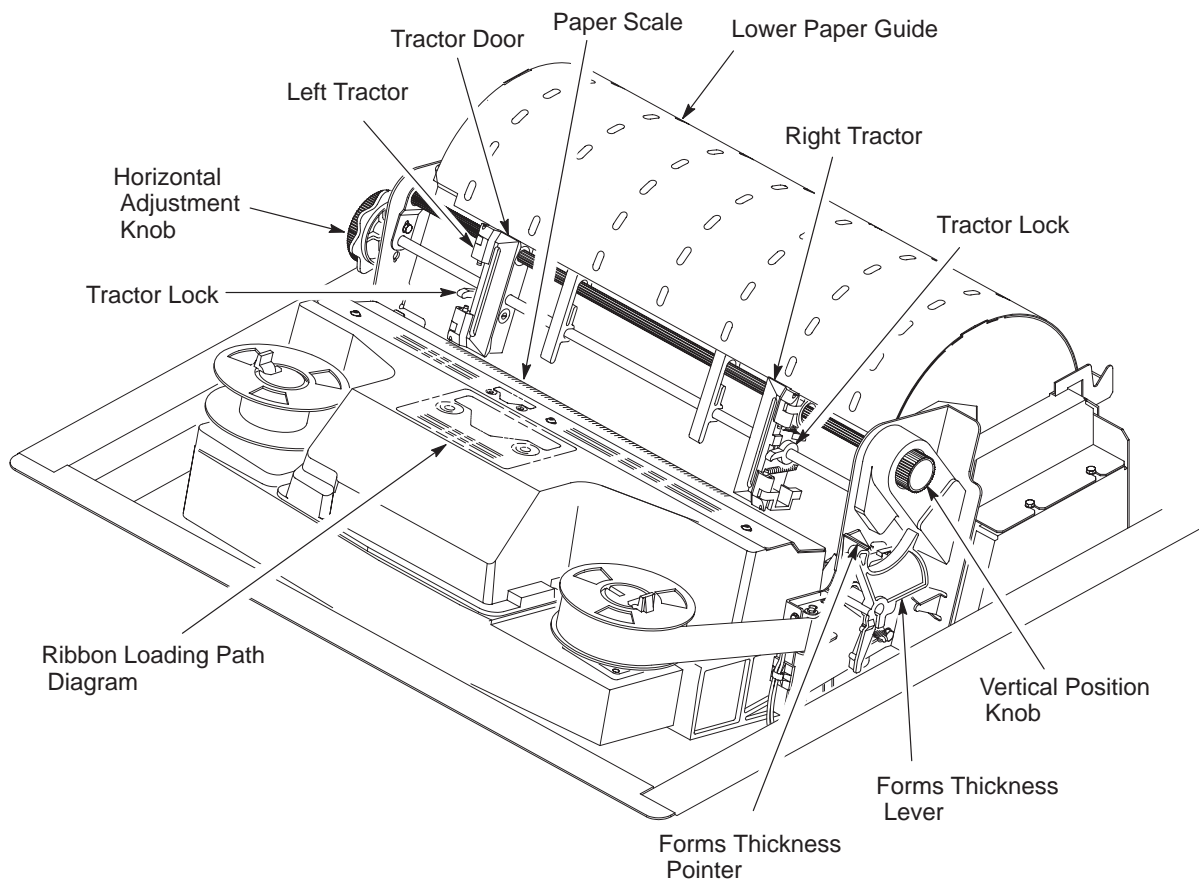

**Figure 2-2. Pedestal Model Printer Dimensions**

## Printer Component Locations

---

Familiarize yourself with the names and locations of the printer components shown in the following figures *before* continuing with the rest of the installation procedure.



**Figure 2-3. Cabinet Model Component Locations**

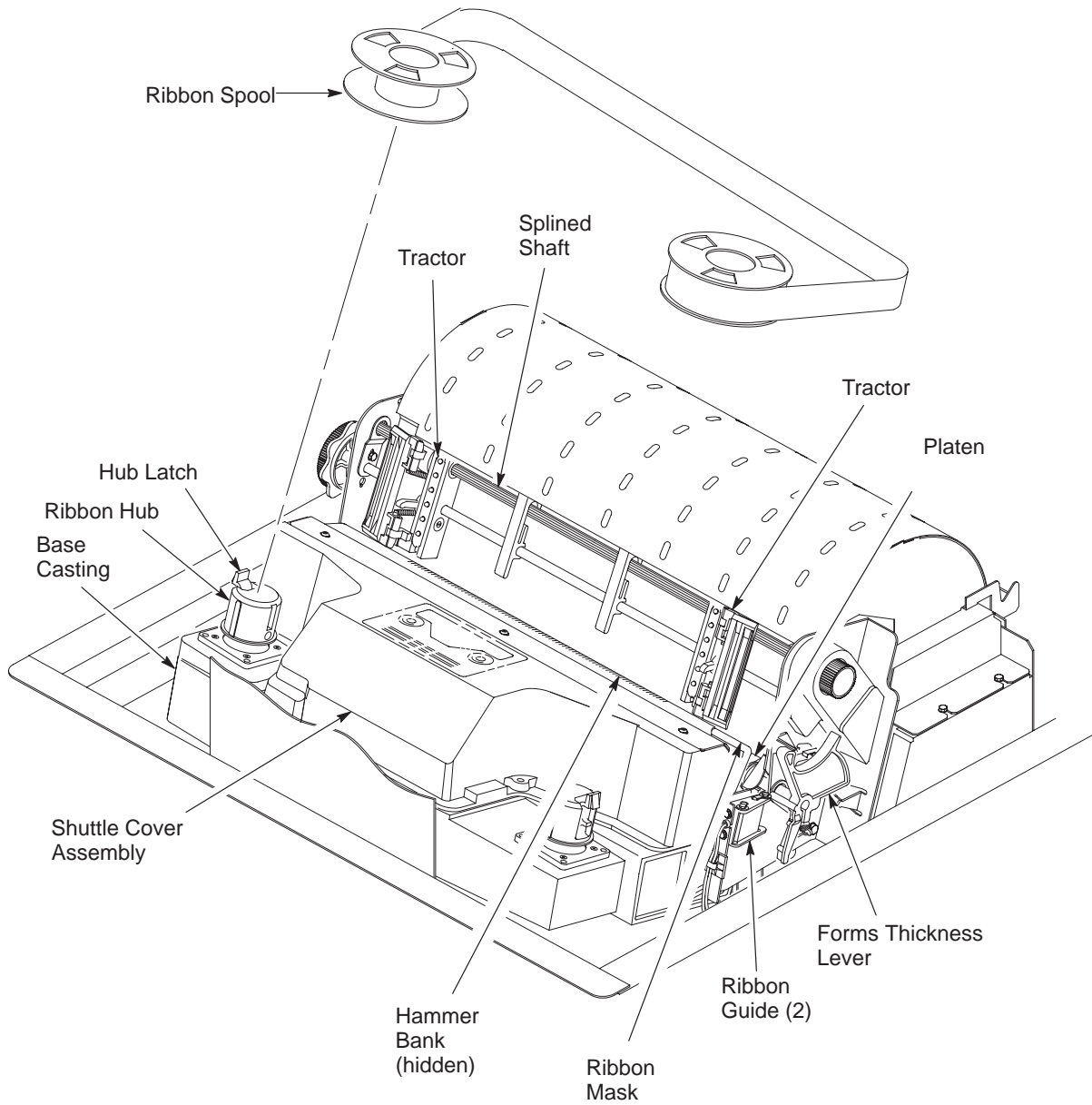

**Figure 2-3. Cabinet Model Component Locations (Cont.)**

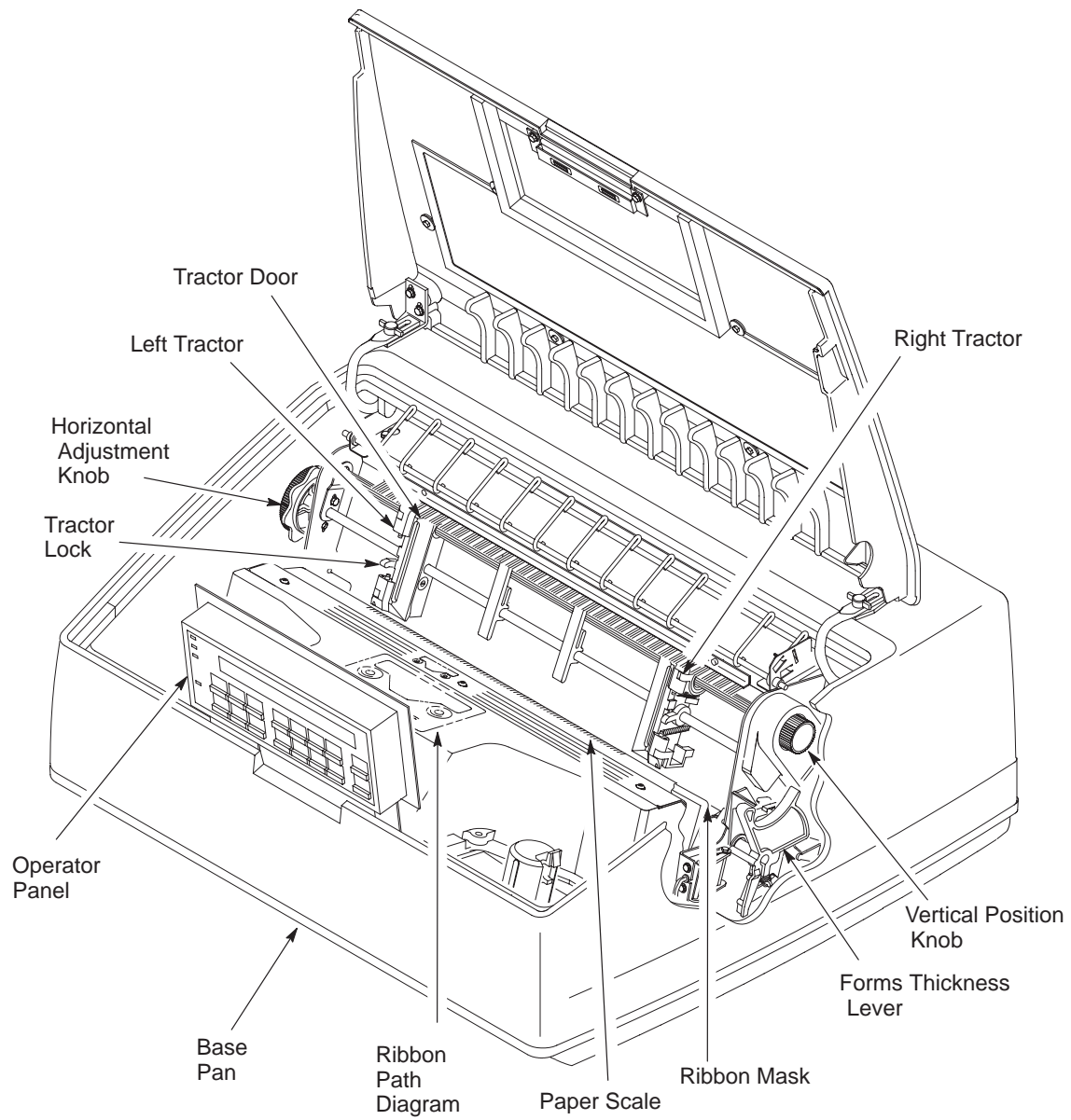

**Figure 2-4. Pedestal Model Component Locations**

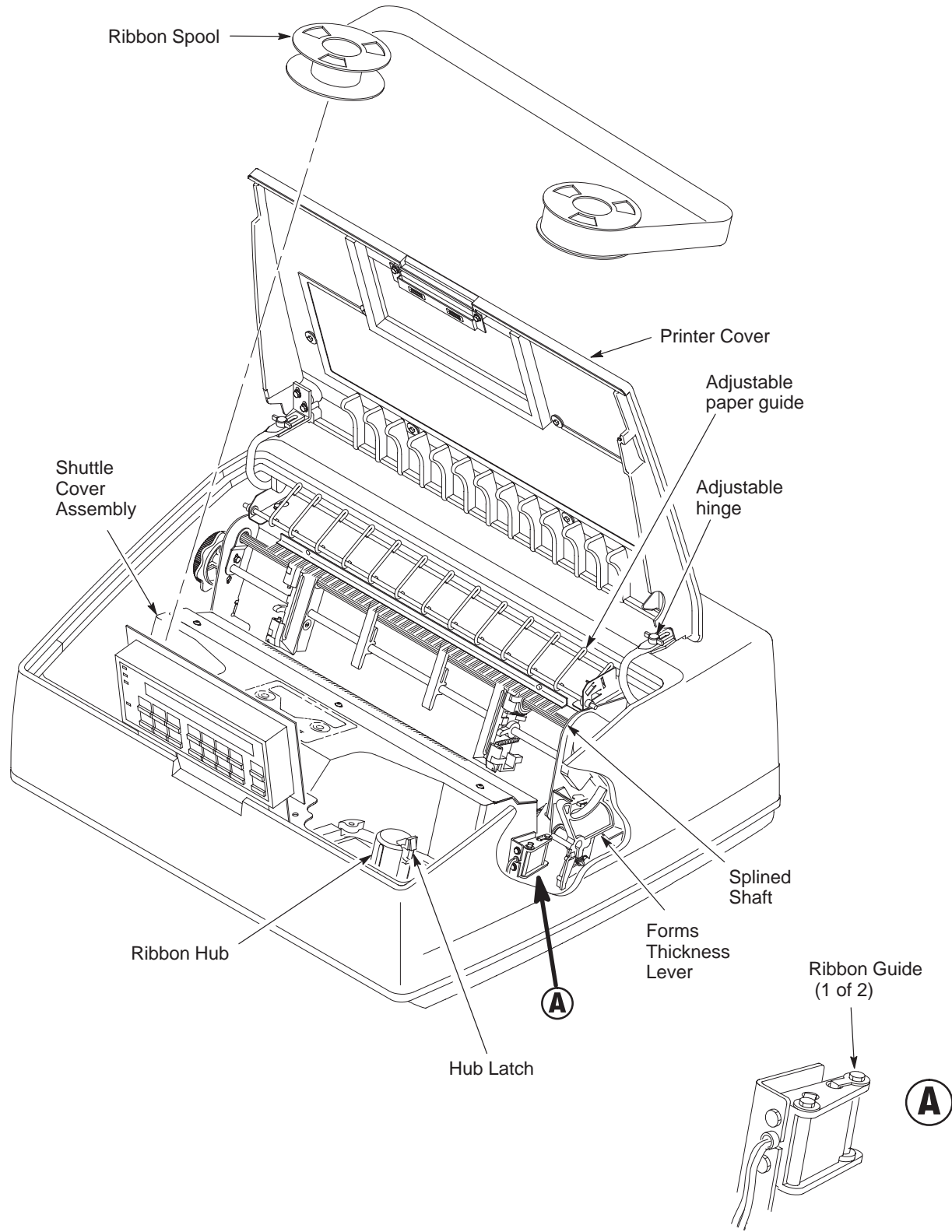

**Figure 2-4. Pedestal Model Component Locations (Cont.)**

## **Removing Packing Material**

---

Follow the instructions on the shipping package to perform these steps:

1. Remove shipping restraints from front of shipping pallet.
2. Move printer from shipping pallet.
3. Remove remaining shipping restraints from pallet.
4. Remove remaining packing material.

## **Removing Shipping Restraints (Cabinet Models)**

---

Cardboard packing, protective foam, and tie wraps protect printer mechanisms from possible damage during shipment. You must remove these shipping restraints before you operate the printer.

Save the cardboard packing and extra tie wraps with the other packing materials.

To avoid shipping damage, reinstall the shipping restraints whenever the printer is moved or shipped. To reinstall the shipping restraints, simply reverse the steps in this section.



## Remove the Cardboard Packing

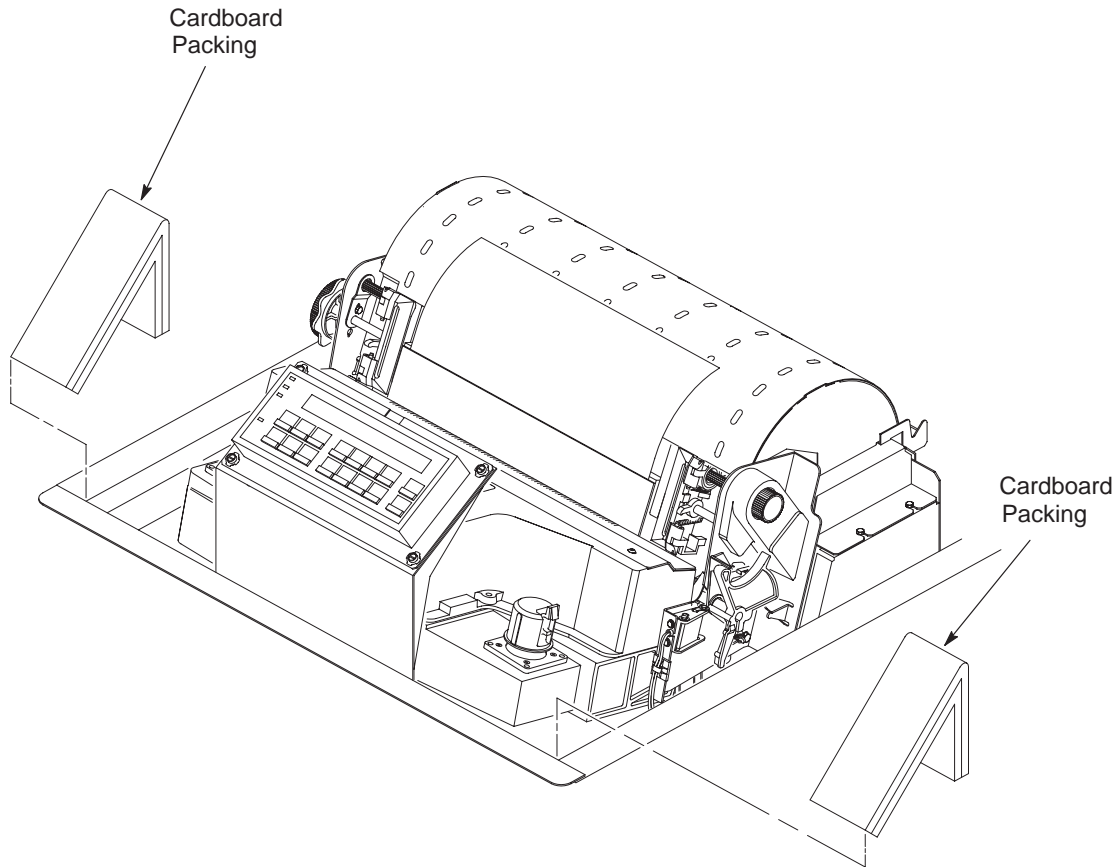

**Figure 2-5. Removing the Cardboard Packing**

1. Raise the printer cover.
2. Remove the cardboard packing. (See Figure 2-5.)

## Remove the Hammer Bank Protective Foam

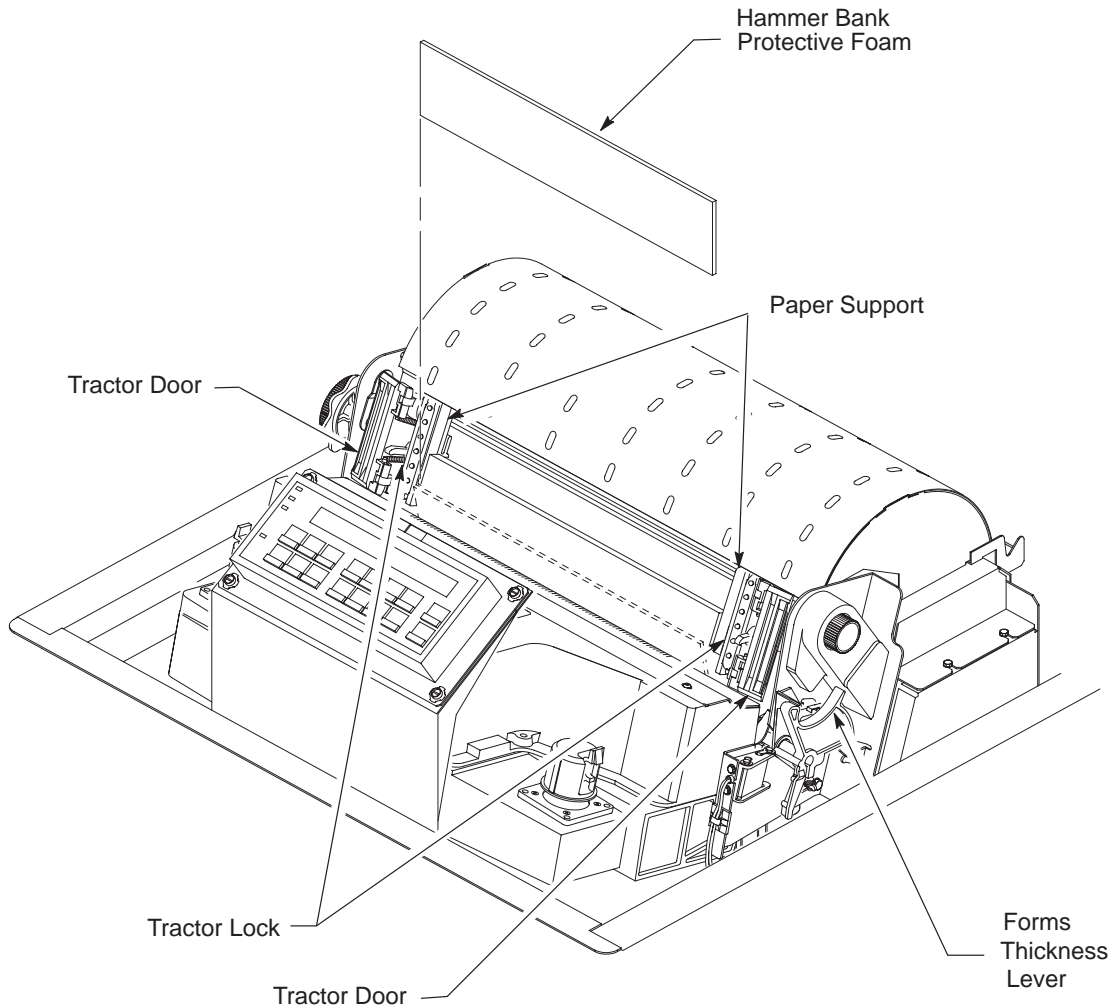

**Figure 2–6. Removing the Hammer Bank Protective Foam**

1. Open the tractor doors. Push the tractor locks down. Slide the tractors and paper supports outward as far as they will go. (See Figure 2–6.) The forms thickness lever should be in the fully open (raised) position.
2. Remove the envelope that contains the sample configuration printout. Store this in the pouch that is attached to the left interior side of the cabinet.
3. Lift the hammer bank protective foam and remove it from between the ribbon mask and the platen.

## Remove the Platen Protective Foam

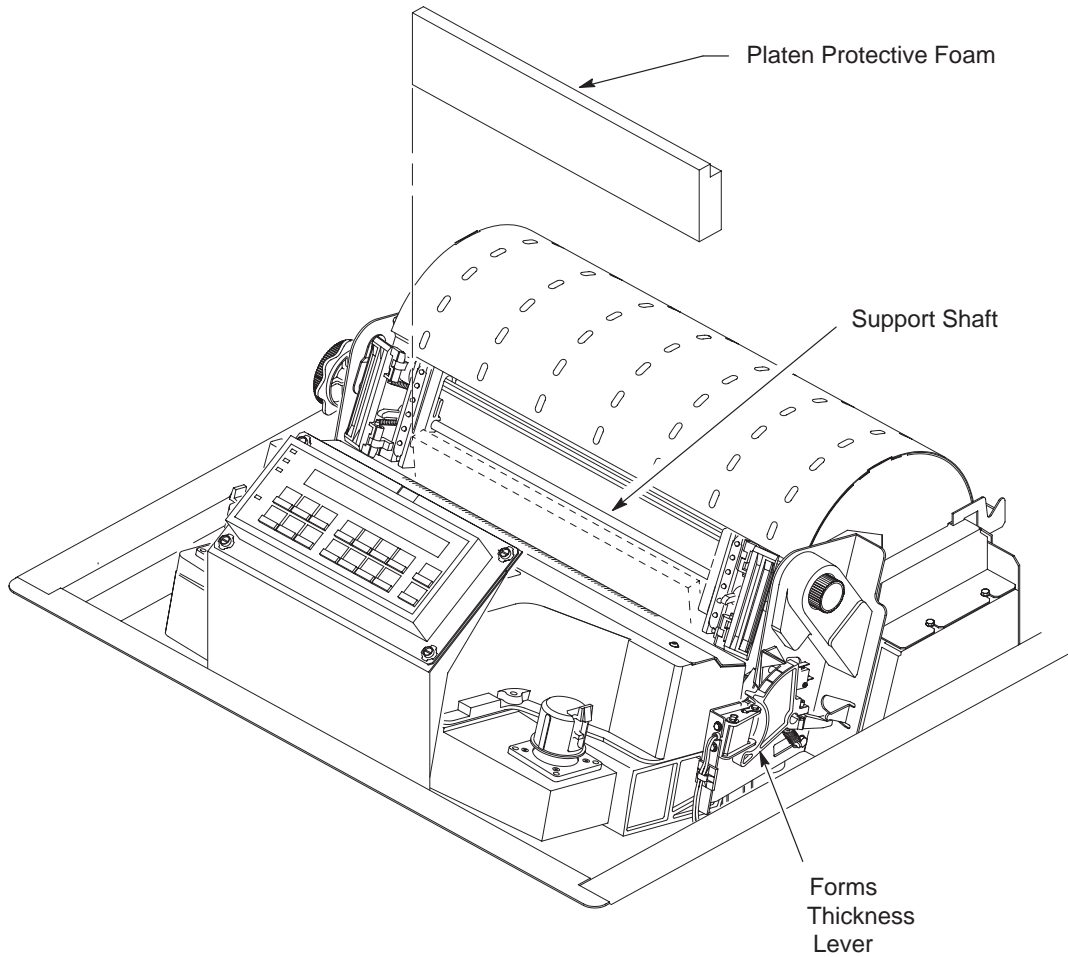

**Figure 2–7. Removing the Platen Protective Foam**

1. Rotate the forms thickness lever downward (to position “A”). (See Figure 2–7.)
2. Rotate the platen protective foam toward the front of the printer and out from under the support shaft. Remove the platen protective foam.

## Remove the Protective Film

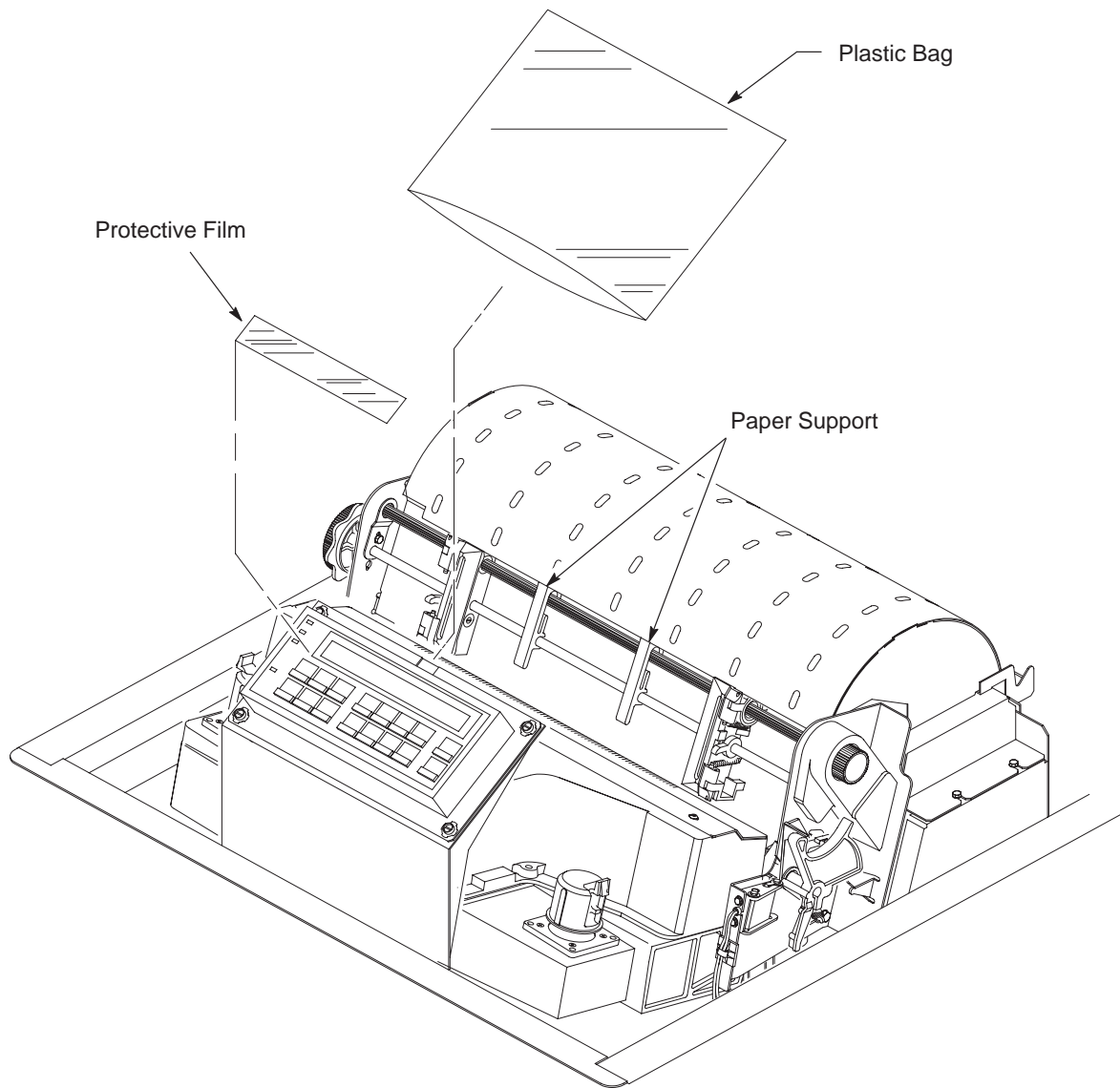

**Figure 2–8. Removing the Protective Film**

1. Slide the two paper supports toward the center of the support shaft. Position them so that they divide the space between the tractors into three approximately equal segments. (See Figure 2–8.)
2. Carefully remove the protective plastic bag from the operator panel.
3. Carefully peel off the tape and lift the protective film off the operator panel message display.

## Release the Paper Chains

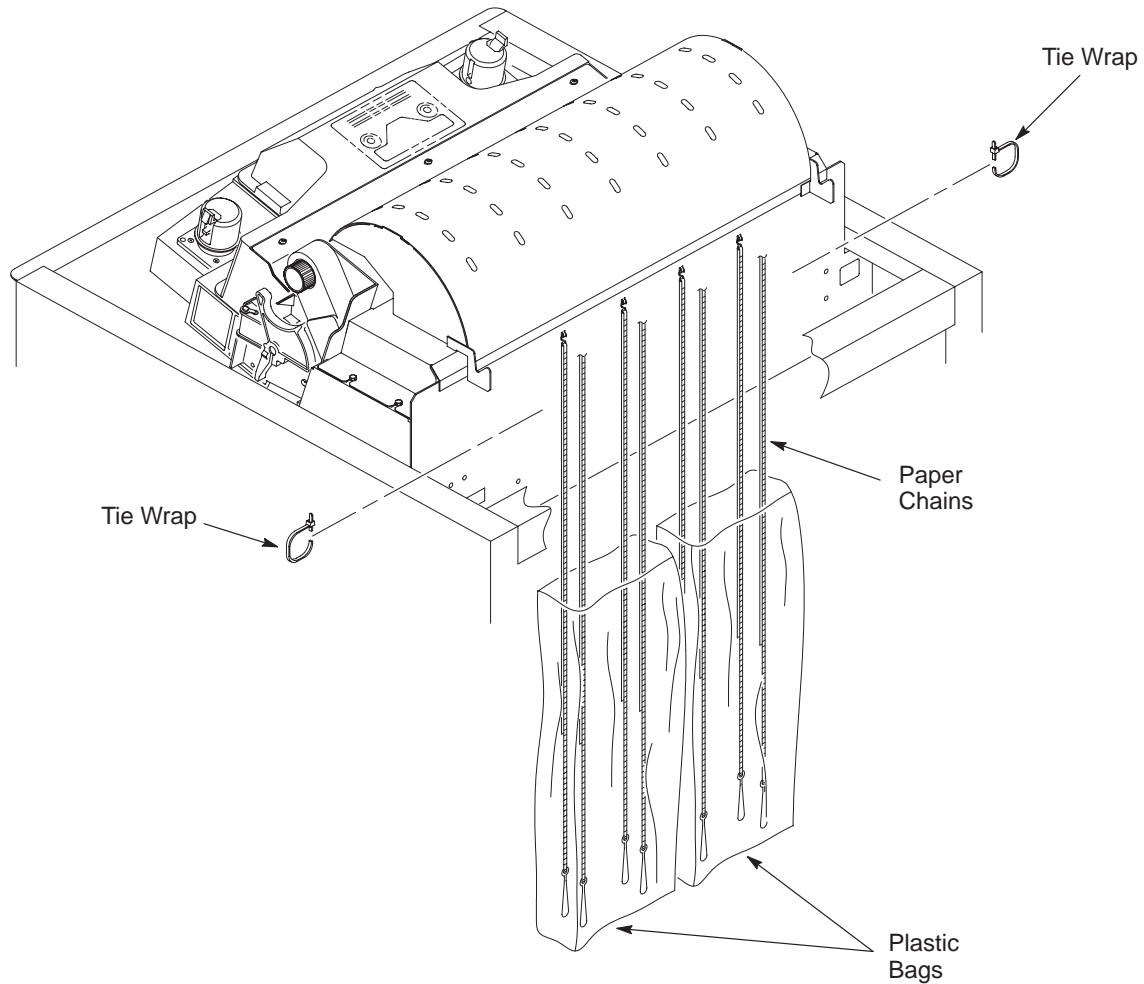

**Figure 2–9. Releasing the Paper Chains**

1. Open the rear cabinet door.
2. Cut the tie wraps and release the paper chains from the bags at the top rear of the printer frame. Remove the tie wraps and bags. (See Figure 2–9.)
3. Make sure each chain hangs freely, with no kinks or knots.

## **Removing Shipping Restraints (Pedestal Models)**

---

Protective films and foam blocks protect printer mechanisms from possible damage during shipment. You must remove these shipping restraints before you operate the printer.

Save the foam blocks with the other packing materials.

To avoid shipping damage, reinstall the shipping restraints whenever the printer is moved or shipped. To reinstall the shipping restraints, simply reverse the steps in this section.

## Remove the Protective Film

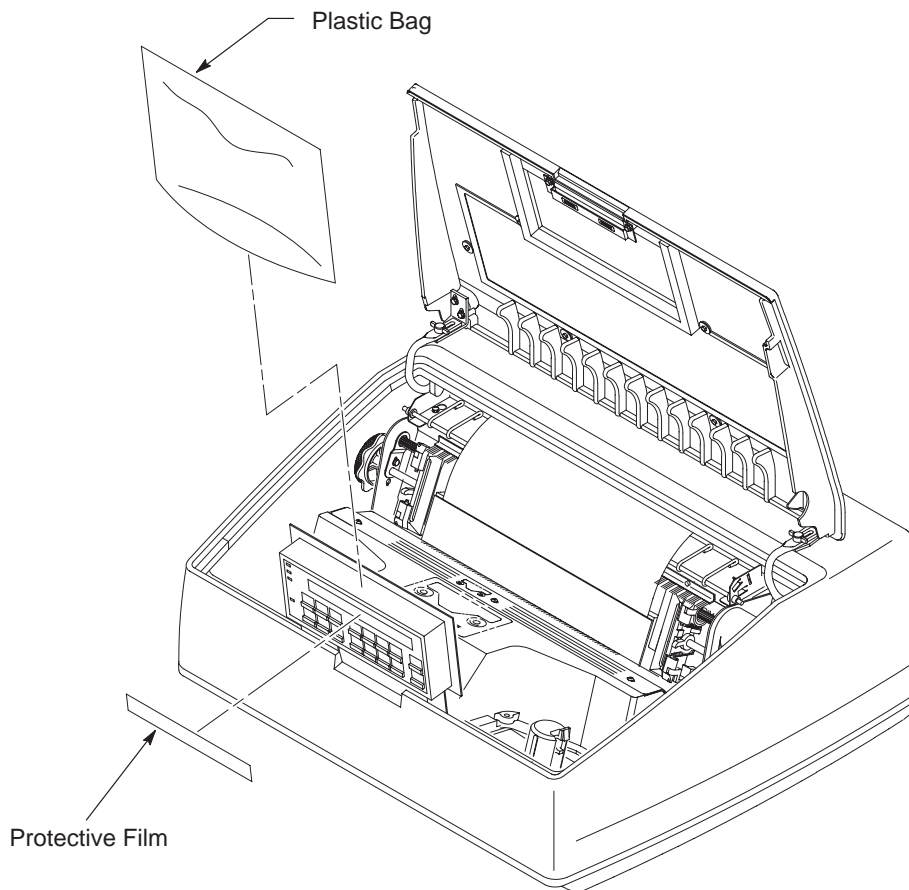

**Figure 2–10. Removing the Protective Film**

1. Raise the printer cover.
2. Remove the cardboard packing.
3. Carefully remove the protective plastic bag from the operator panel. (See Figure 2–10.)
4. Carefully peel off the tape and lift the protective film off the operator panel message display.

## Remove the Hammer Bank Protective Foam

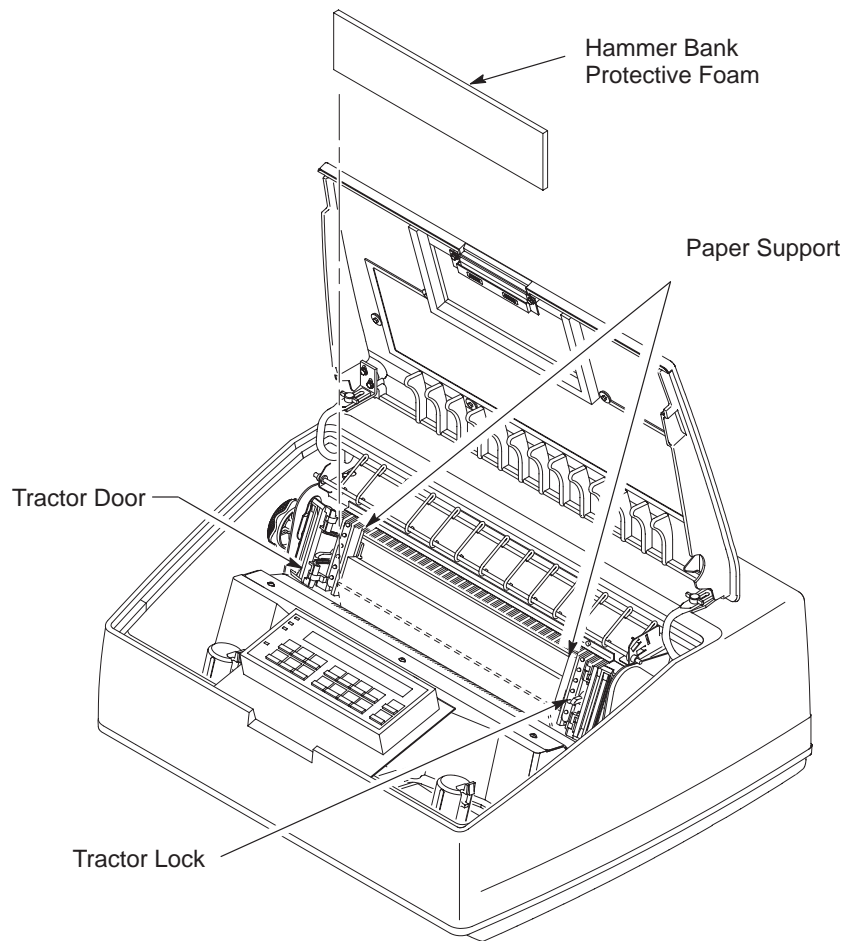
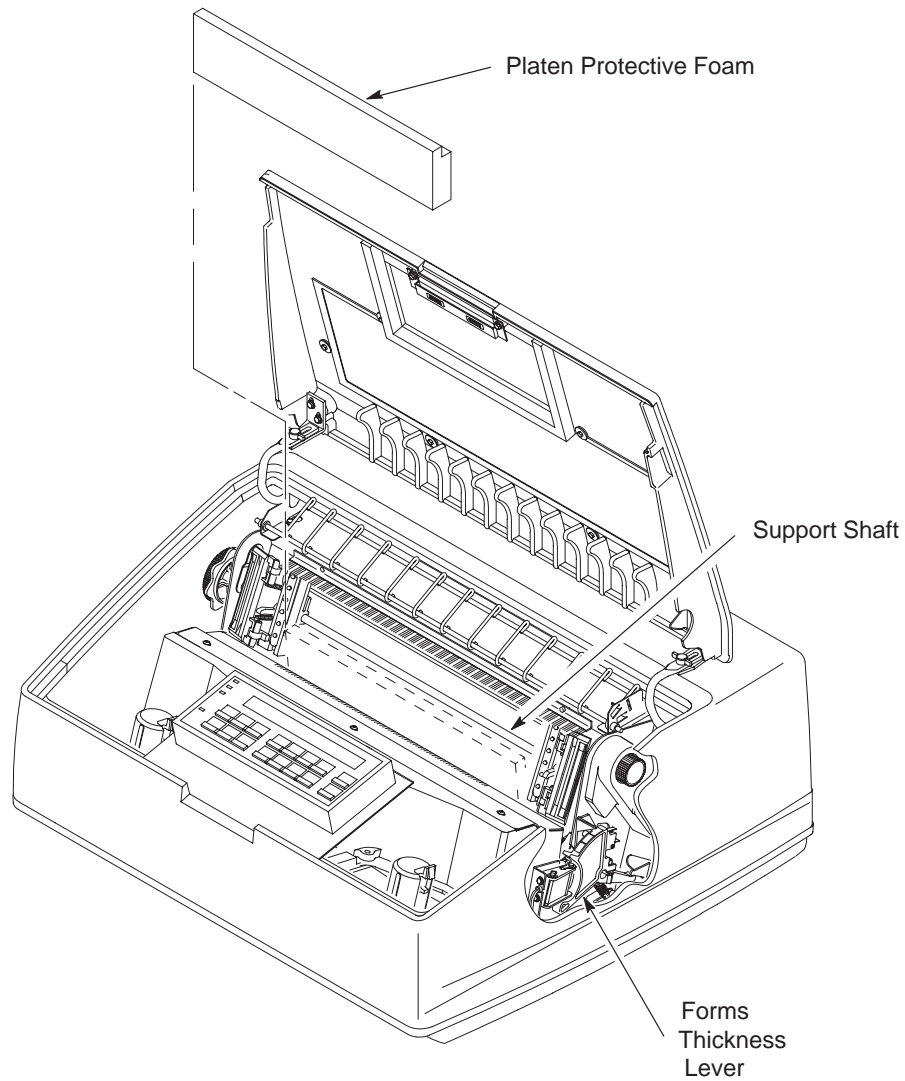

**Figure 2–11. Removing the Hammer Bank Protective Foam**

1. Open the tractor doors. Push the tractor locks down. Slide the tractors and paper supports outward as far as they will go. (See Figure 2–11.) The forms thickness lever should be raised (in the fully open position).
2. Remove the envelope that contains the sample configuration printout.
3. Lift the hammer bank protective foam and remove it from between the ribbon mask and the platen.



## Remove the Platen Protective Foam



**Figure 2–12. Removing the Platen Protective Foam**

1. Rotate the forms thickness lever downward (to position “A”). (See Figure 2–12.)
2. Rotate the platen protective foam toward the front of the printer and out from under the support shaft. Remove the platen protective foam.

## Attach the Input Paper Shelf and Output Basket

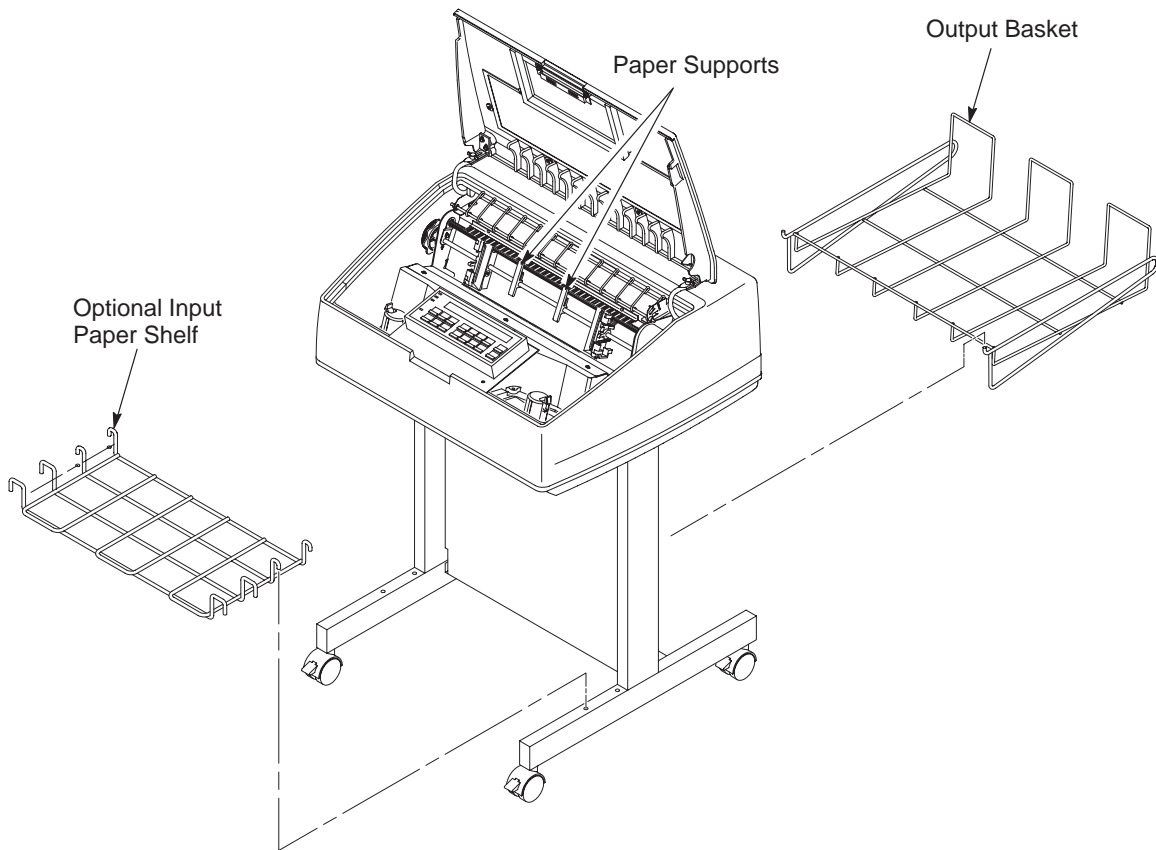

**Figure 2–13. Attaching the Input Paper Shelf and Output Basket**

1. Slide the two paper supports toward the center of the support shaft. Position them so that they divide the space between the tractors into three approximately equal segments. (See Figure 2–13.)
2. Place the output basket in the holes on the back of the printer.
3. Place the input paper shelf (which is an optional feature) in the holes in the front of the pedestal base.

## Connect the Interface and Power Cables (Cabinet Models)

---

1. Verify that the voltage source at the printer site conforms to the requirements specified on page 2–5. Make sure that the printer power switch is set to Off. (See Figure 2–14.)
2. Open the front cabinet door, remove and open the box containing the power cord, printer ribbon, and operator panel overlay label. Refer to Appendix A, “Printer Specifications,” for recommended cables. Documentation is stored in a pouch container on the right interior side of the cabinet.
3. Referring to Figure 2–14, connect the (customer-supplied) interface cable from the host computer to the appropriate printer interface connector:
  - a. Remove the cover from the I/O connector(s) you have selected.
  - b. Locate the notch in the lower left corner of the back of the cabinet. Hold the I/O cable below its connector, and gently push the cable through the diagonal openings in the two plastic grommets seated in the notch. (See Figure 2–14.)
  - c. Pull the cable up through the notch until it reaches the I/O plate; attach the cable connector to the printer interface connector.
4. Thread the power cable connector up through the notch in the lower right back corner of the cabinet (see Figure 2–14). Plug the power cord into the printer AC power connector, then into the AC power outlet.

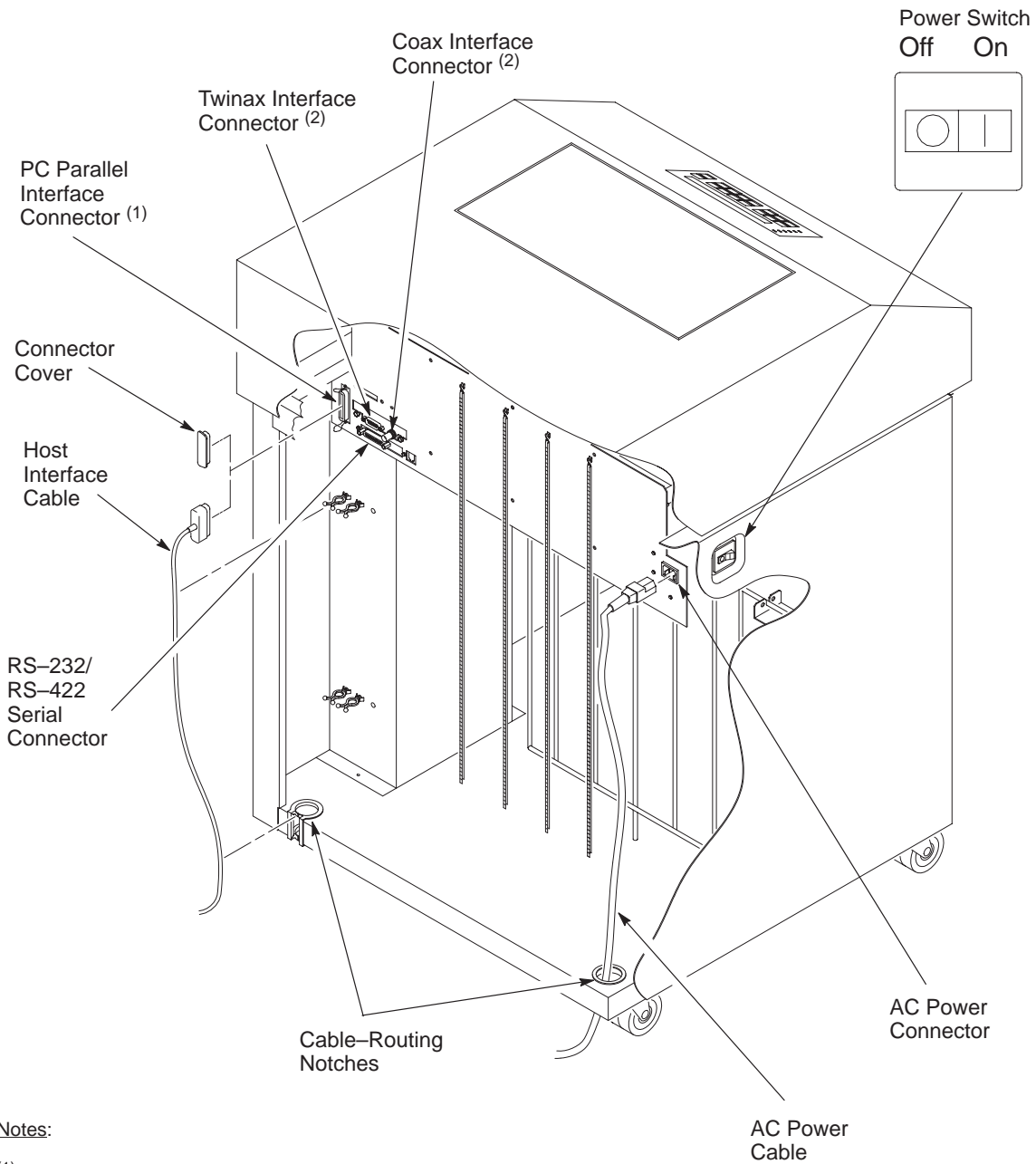

**Notes:**

(1) The Dataproducts adapter feature attaches to the PC Parallel interface connector.

(2) Twinax and Coax Interfaces appear only if these features are installed.

The Multi-Platform Interface Coax/Twinax feature is not shown in this illustration. Refer to the Coax/Twinax Multi-Platform Interface Option Installation and Operation Guide for an illustration of this feature.

**Figure 2-14. Interface and Power Cable Connections, Cabinet Models**

## Connect the Interface and Power Cables (Pedestal Models)

---

1. Verify that the voltage source at the printer site conforms to the requirements specified on page 2–5. Make sure that the printer power switch is set to Off. (See Figure 2–15.)
2. Open the box containing the power cord, printer ribbon, and operator panel overlay label. Refer to Appendix A, “Printer Specifications,” for recommended cables.
3. Referring to Figure 2–15, connect the (customer-supplied) interface cable from the host computer to the appropriate printer interface connector:
  - a. Remove the cover from the I/O connector(s) you have selected.
  - b. Attach the cable connector to the printer interface connector.
4. Plug the power cord into the printer AC power connector, then into the AC power outlet (see Figure 2–15).

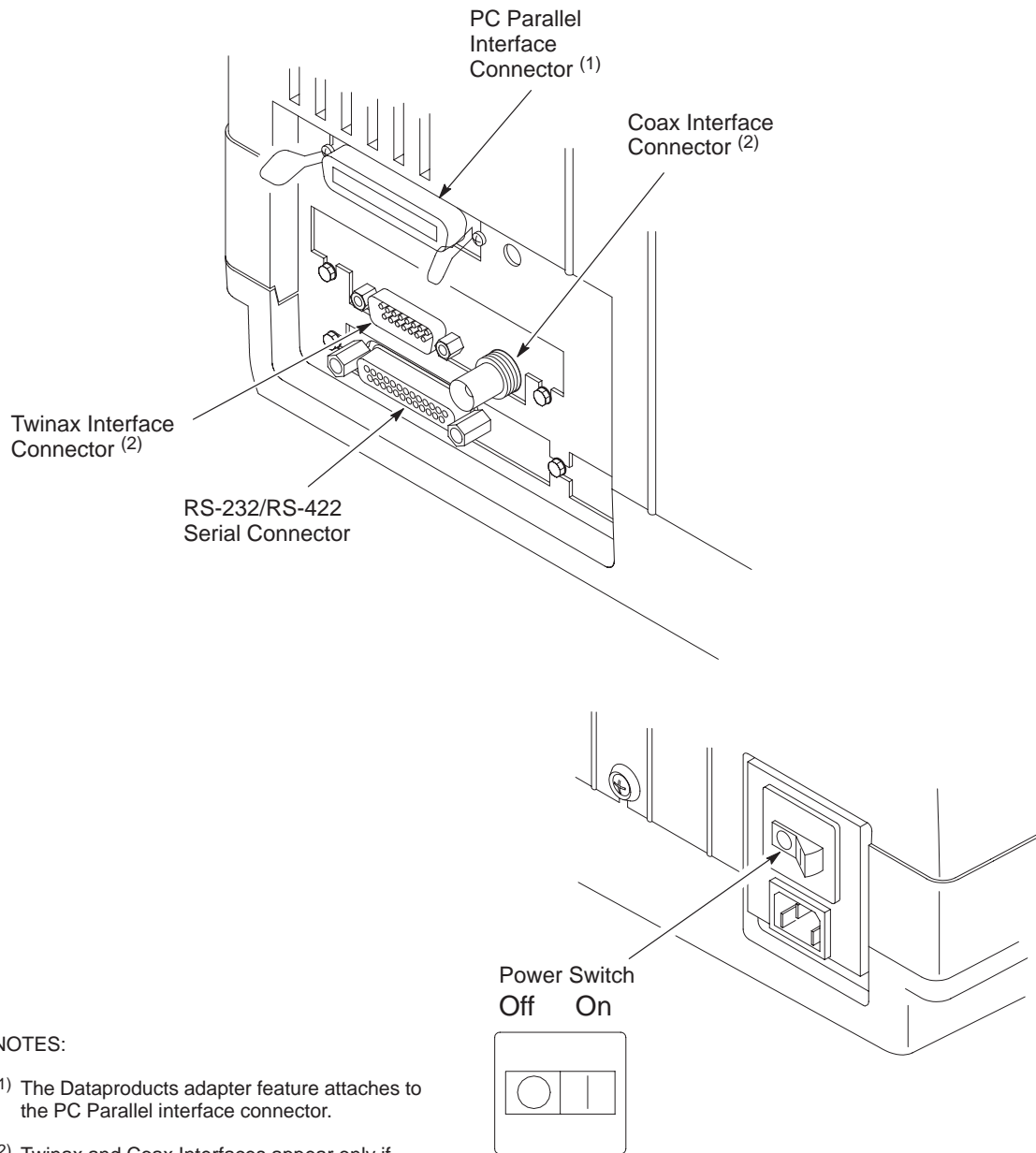

**NOTES:**

- (1) The Dataproducts adapter feature attaches to the PC Parallel interface connector.
- (2) Twinax and Coax Interfaces appear only if these features are installed.

The Multi-Platform Interface Coax/Twinax feature is not shown in this illustration. Refer to the Coax/Twinax Multi-Platform Interface Option Installation and Operation Guide for an illustration of this feature.

**Figure 2-15. Interface and Power Cable Connections, Pedestal Models**

## Attach the Operator Panel Overlay Label

---

Attach the operator panel overlay label by adhering it to your operator panel.  
(See Figure 2–16.)

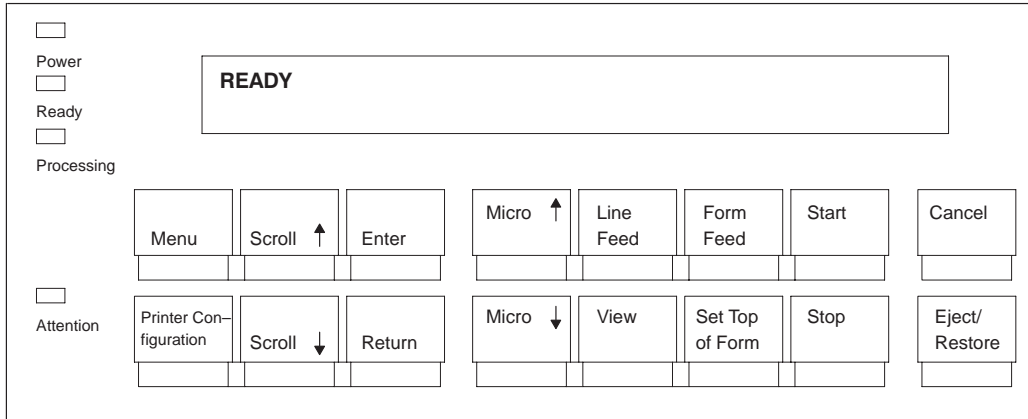
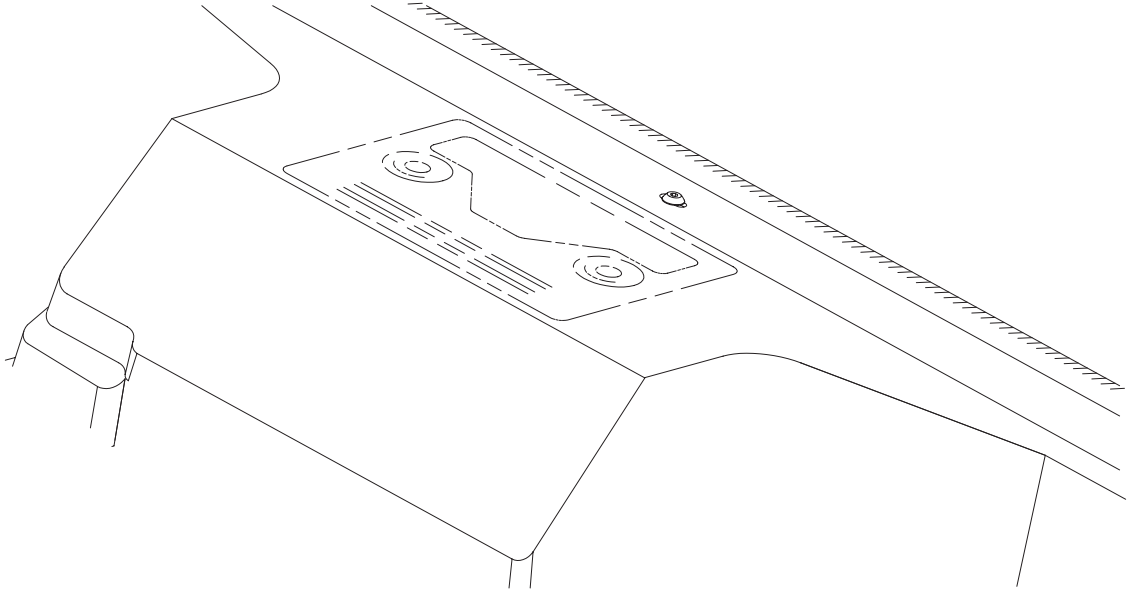

**Figure 2–16. The Operator Panel Overlay Label**

## Install the Ribbon

---

This section explains how to install the ribbon for the first time.



**Figure 2–17. Ribbon Path Diagram Location**

1. Refer to the ribbon path diagram molded onto the shuttle cover for the following steps. (See Figure 2–17.)



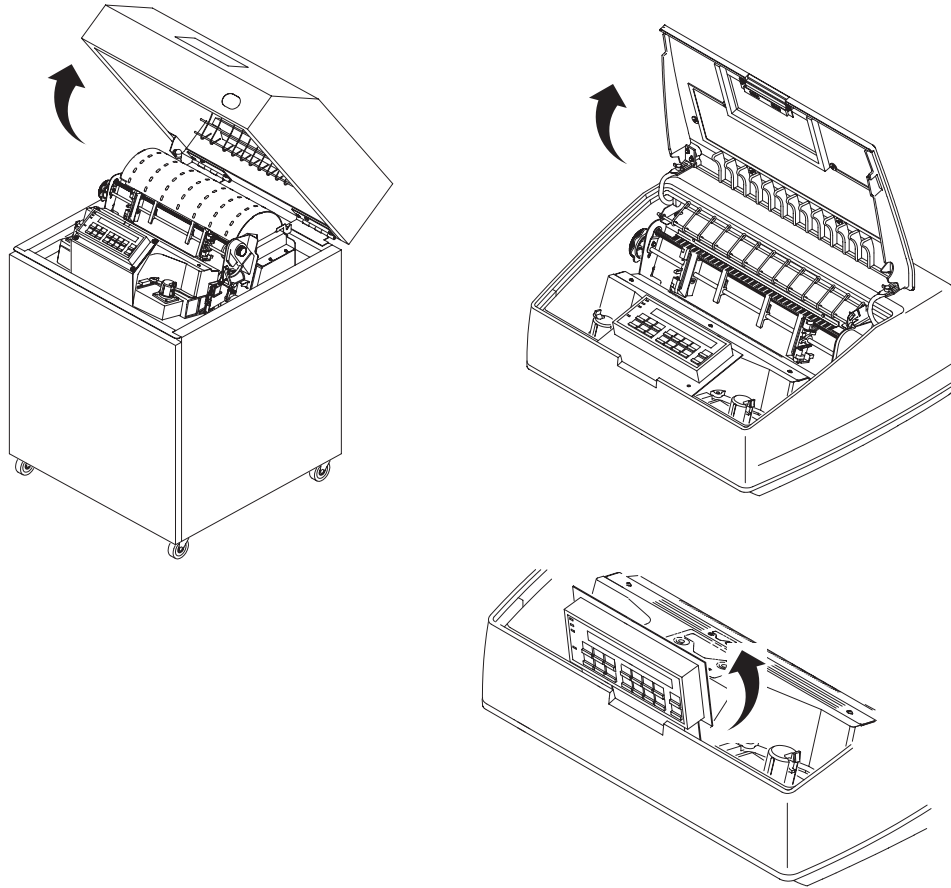

**Figure 2–18. Opening the Printer Cover**

2. Open the printer cover. (See Figure 2–18.)
3. On pedestal models, swing the operator panel out of the way. The operator panel can be pulled toward you to provide clearance. (See Figure 2–18.)

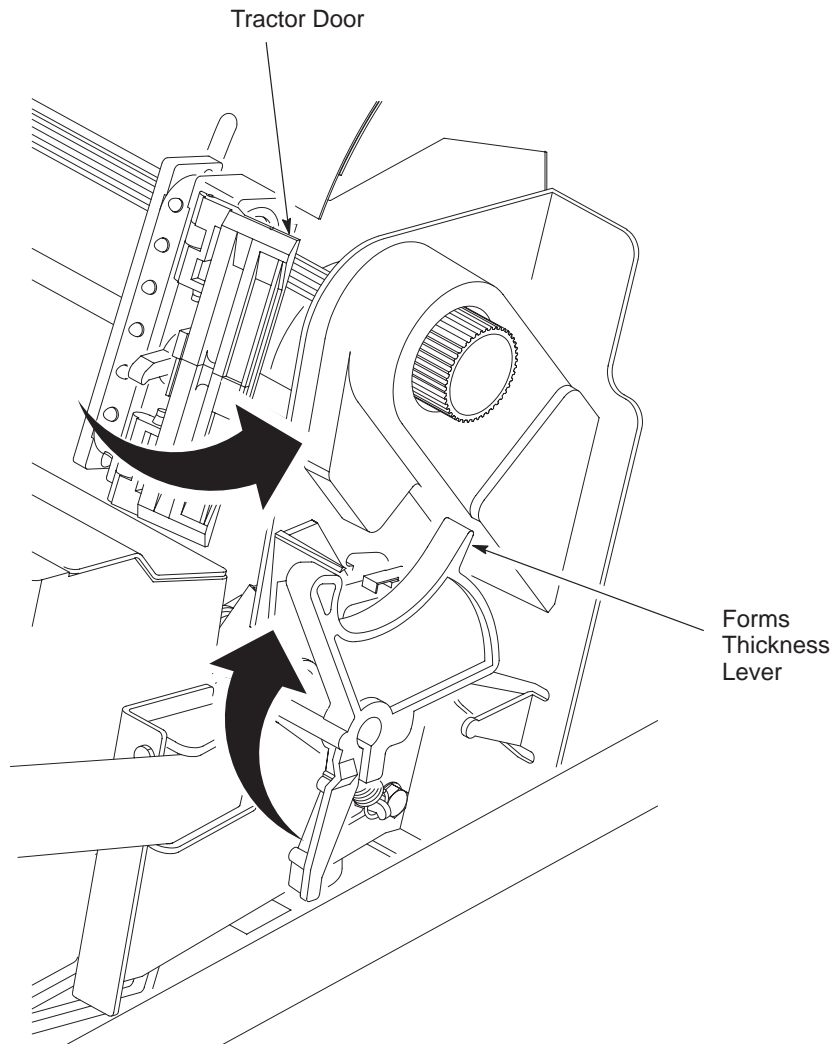

**Figure 2–19. Forms Thickness Lever**

4. Raise the forms thickness lever as far as it will go. (See Figure 2–19.)
5. Swing open the tractor doors. (See Figure 2–19.)
6. Remove the ribbon spools from the package.

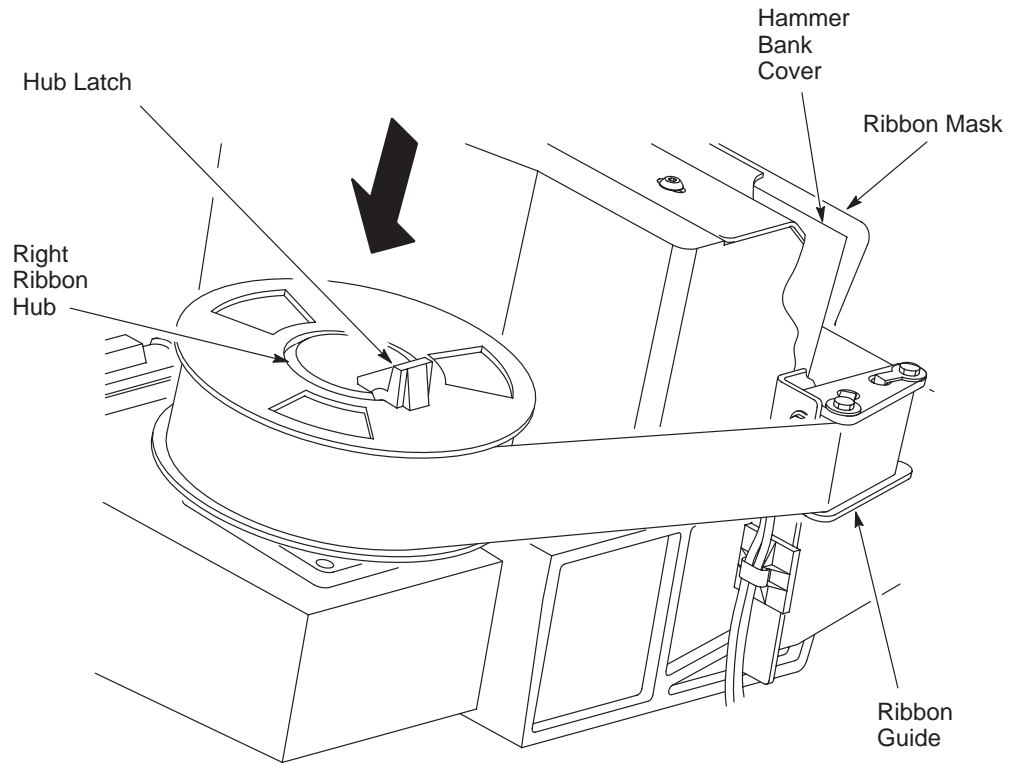

**Figure 2–20. Right Ribbon Hub**

7. With the ribbon to the outside, squeeze the right hub latch and place one spool on the right ribbon hub. Press the spool down until the hub latch snaps into place. (See Figure 2–20.)

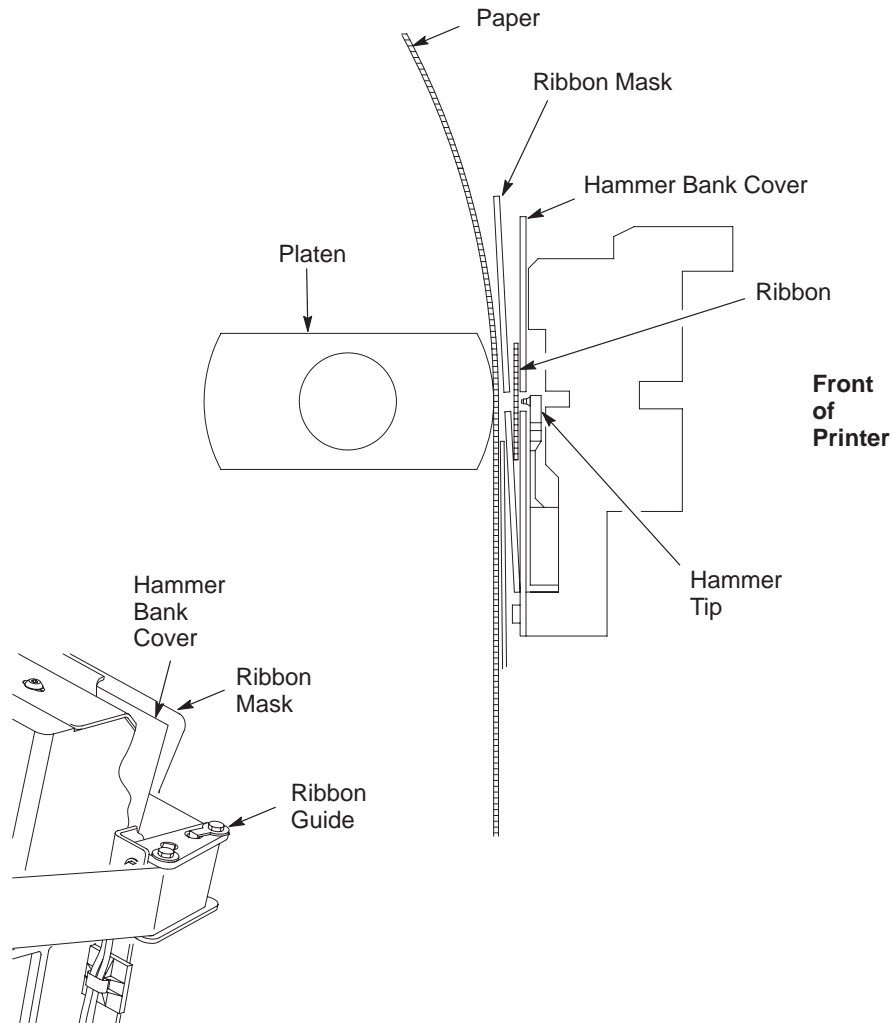

**Figure 2–21. Ribbon Path**

8. Referring to Figure 2–21 and the ribbon path diagram on the shuttle cover, thread the ribbon as follows:

Starting from the right ribbon spool, thread the ribbon around the right ribbon guide, under the right tractor door, between the hammer bank cover and ribbon mask, and along the ribbon path to the left ribbon guide.

**NOTE:** The ribbon must not be twisted. A twisted ribbon can lower print quality, shorten ribbon life, and cause paper or ribbon jams.

9. Referring to Figure 2–22, squeeze the left hub latch and place the remaining spool on the left ribbon hub. Press the spool down until the hub latch snaps into place. Turn the right spool by hand and check to ensure that the ribbon tracks correctly in the ribbon path and around the ribbon guides.
10. Close the forms thickness lever.
11. Continue with the next procedure to load paper in the printer.

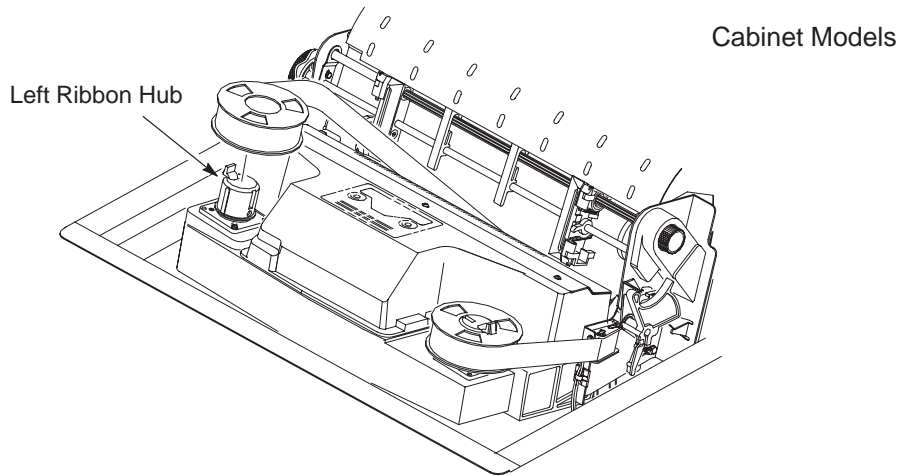

NOTE:

Raise the Operator Panel when replacing ribbon on Pedestal models.

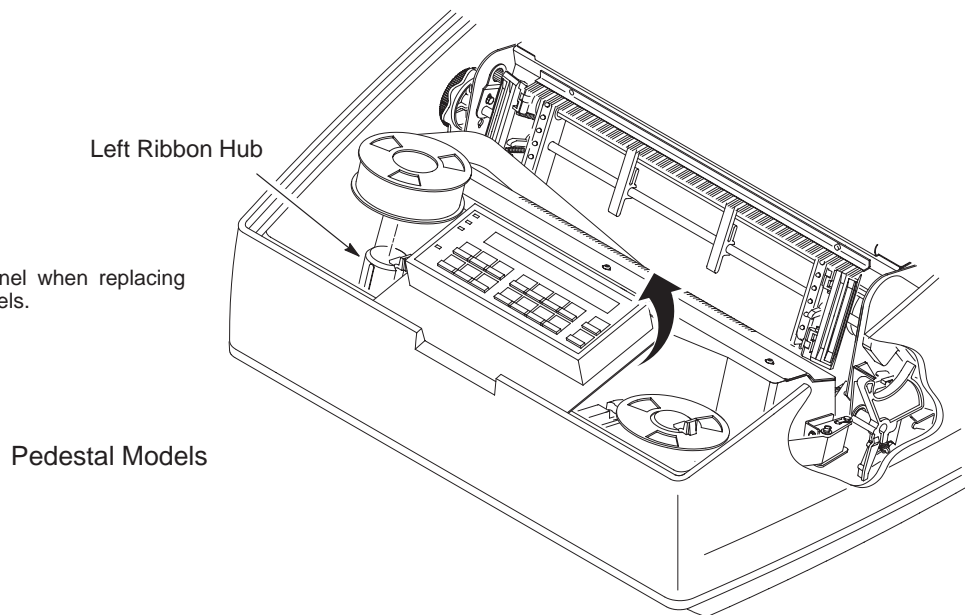
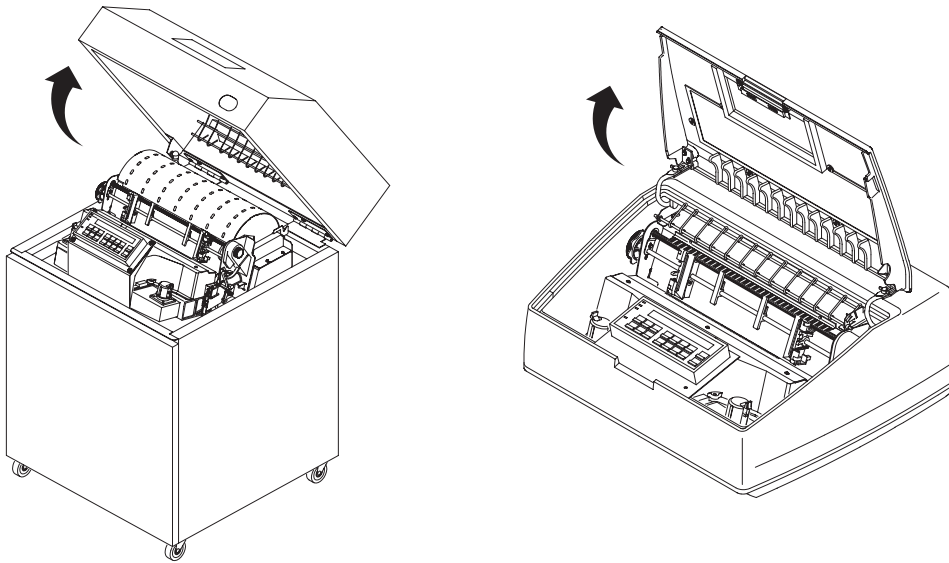

**Figure 2-22. Left Ribbon Hub**

## Load the Paper

---

This section explains how to load paper for the first time.



**Figure 2–23. Opening the Printer Cover**

1. Open the printer cover. (See Figure 2–23.)

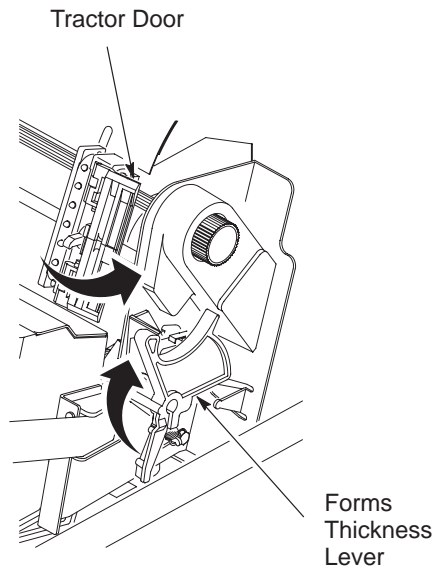

**Figure 2–24. Forms Thickness Lever**

2. Raise the forms thickness lever as far as it will go. (See Figure 2–24.)
3. Swing open the tractor doors. (See Figure 2–24.)



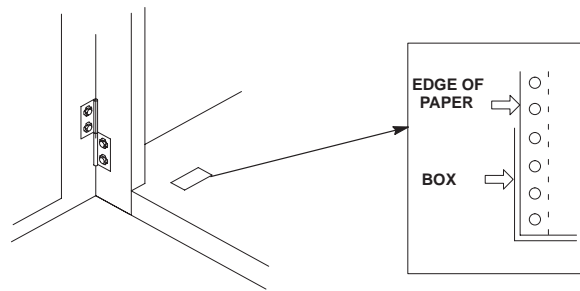

**Figure 2–25. Paper Supply Label Location (Cabinet Models Only)**

4. Prepare the paper supply:
  - Cabinet models: Open the front door of the printer cabinet. Place the paper supply inside the printer, on the floor of the cabinet. Align the paper supply with the front label on the floor of the printer. Ensure that the paper pulls freely from the box. (See Figure 2–25.)
  - Pedestal models: Place the paper supply on the floor in front of the printer, or on the optional paper shelf, if attached. Ensure that the paper pulls freely from the box.

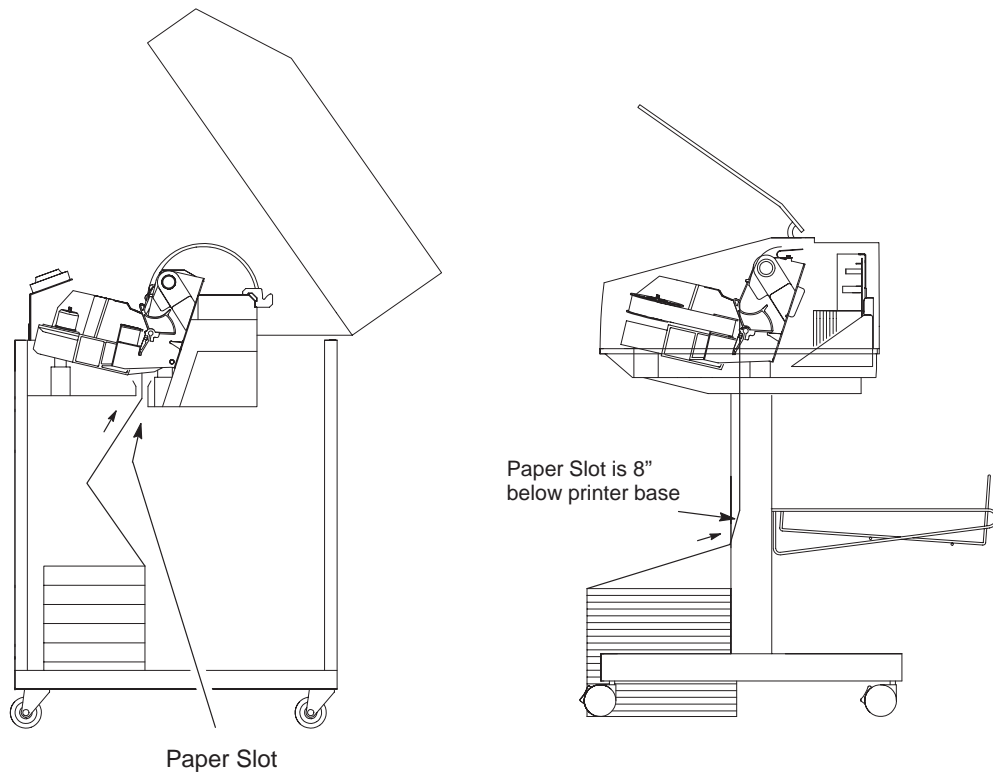

**Figure 2–26. Feeding the Paper**

5. Feed the paper up through the paper slot. On pedestal models, be sure the paper feeds between the two wire guides. Hold the paper in place with one hand (to prevent it from slipping down through the paper slot) while pulling it through from above with your other hand. (See Figure 2–26.)

**NOTE:** For the pedestal model, this procedure shows loading paper when using the rear paper exit. For information on loading paper using the top paper exit, see the Operator’s Guide.

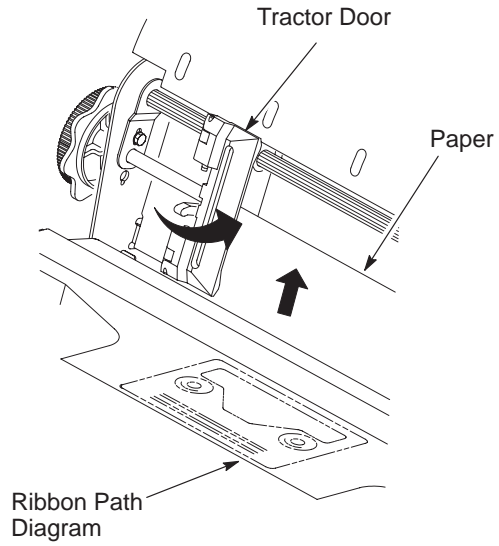

**Figure 2–27. The Left Tractor**

6. Pull the paper above and behind the ribbon mask, which is a silver-colored metal strip. (Refer to the ribbon path diagram on the shuttle cover.) Load the paper onto the left tractor sprockets and close the left tractor door. (See Figure 2–27.)

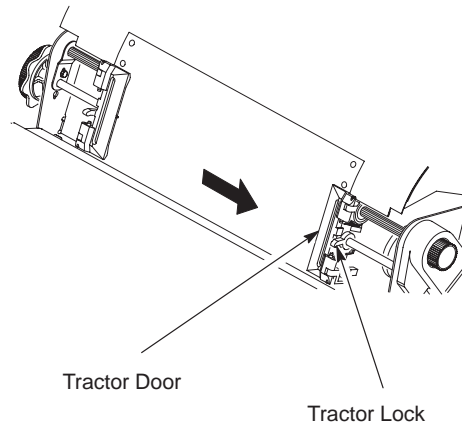

**Figure 2–28. The Right Tractor**

7. Load the paper onto the right tractor and close the right tractor door. Slide the right tractor horizontally to remove any paper slack, then lock it in place. (See Figure 2–28.)

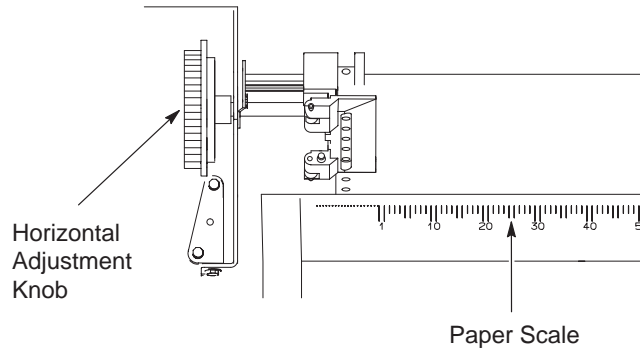

**Figure 2–29. Aligning the Paper**

8. Align the paper according to the paper scale on the shuttle cover by turning the horizontal adjustment knob. Turn the horizontal adjustment knob until the left tractor is aligned with the number “1” on the paper scale. (See Figure 2–29.)

(You can also use this scale to count columns.)

**WARNING**

**<1> To avoid damage to the printer caused by printing on the platen, always align the edge of the left tractor door with the number “1” on the paper scale.**

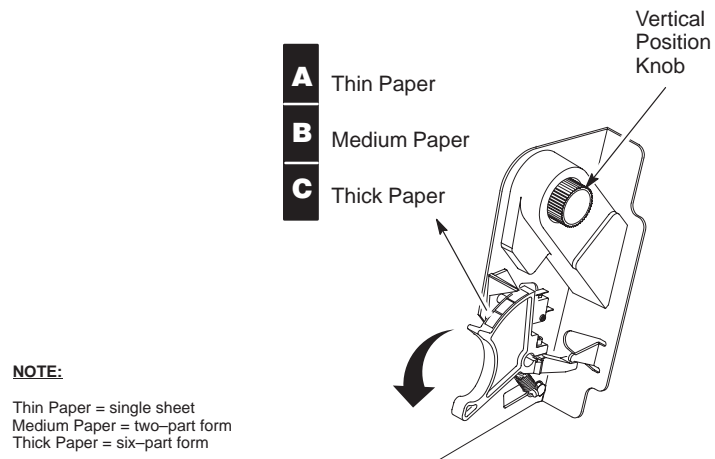

**Figure 2–30. The Forms Thickness Scale**

9. Turn the vertical position knob to feed the paper up into the paper guide assembly. (See Figure 2–30.)
10. Lower the forms thickness lever. Set it to match the paper thickness (refer to the note on shuttle cover). (See Figure 2–30.)
11. Continue with the next procedure to power on the printer.

## Power On the Printer

---

Following are instructions for powering on the printer after you have installed the ribbon and loaded paper.

1. Set the power switch to the ON position. (See Figure 2–31.) The printer loads the power up configuration. A “READY” status message appears on the operator panel message display when initialization is complete.

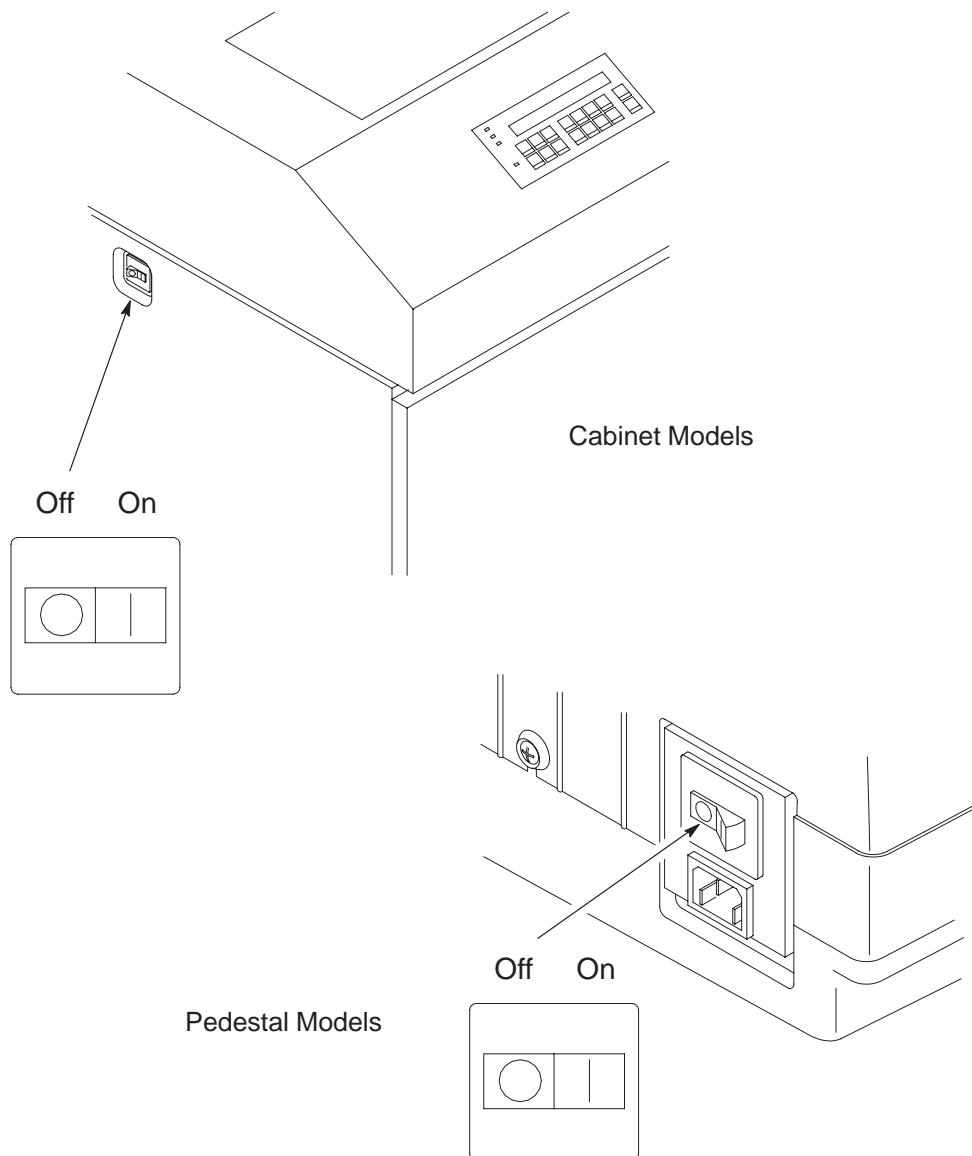

**Figure 2–31. The Power Switch**

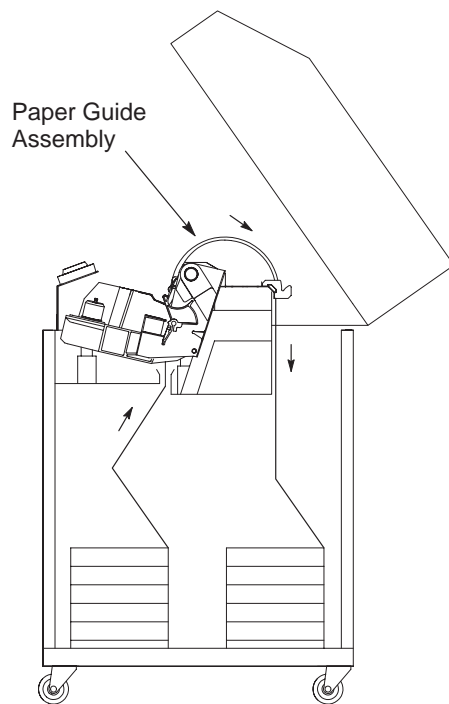
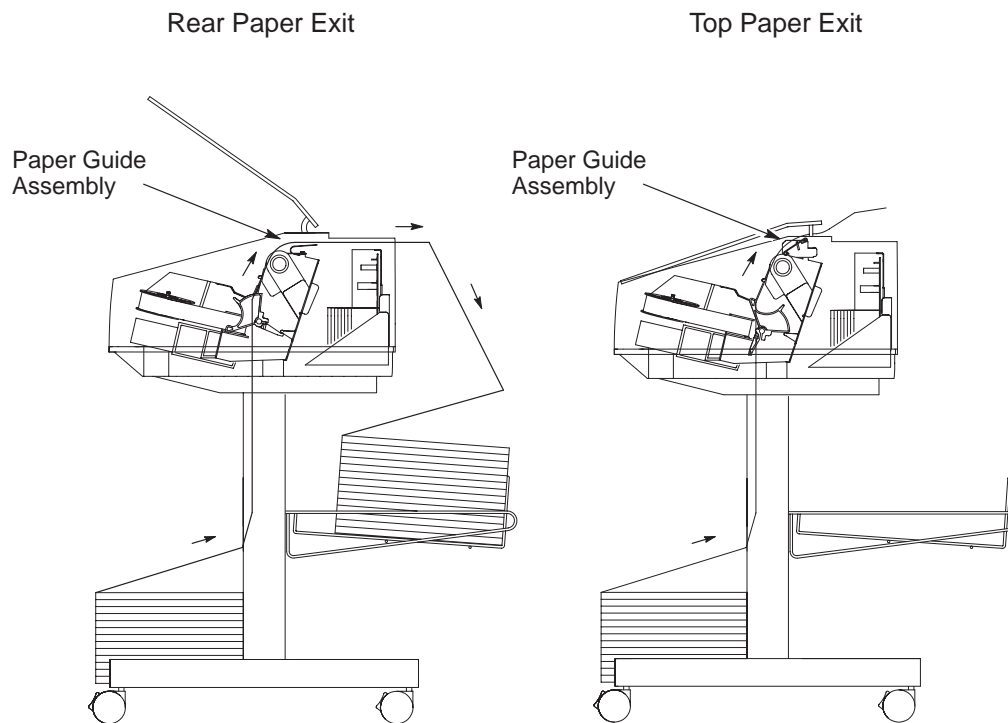

**Figure 2–32. Checking the Paper Feed (Cabinet Models)**

2. Cabinet models:

Check that the paper feeds correctly. Press the **Form Feed** key several times to ensure that the paper feeds properly beyond the tractors and over the paper guide assembly. Ensure that the paper folds the same way in the stacking area as it does in the supply area. (See Figure 2–32.)





**Figure 2–33. Checking the Paper Feed (Pedestal Models)**

3. Pedestal models:

**NOTE:** See the *Operator’s Guide* for instructions on switching between the two paper exit modes.

**NOTE:** When using the top exit paper path, paper can not be stacked. Paper is intended to be removed after each print job is completed.

- For rear paper exit: Press the **Form Feed** key several times to ensure that the paper feeds properly beyond the tractors, over the paper guide assembly, and through the paper exit slot in the rear of the cabinet. Ensure that the paper folds the same way in the stacking area as it does in the supply area. (See Figure 2–33.)
- For top paper exit: Press the **Form Feed** key several times to ensure that the paper feeds properly beyond the tractors, over the paper guide assembly, and through the paper exit slot. (See Figure 2–33.)

4. Cabinet models: Close the front and rear cabinet doors, if the length of the form allows.
5. Cabinet and pedestal models: Continue with the next procedure to set the top-of-form.

## Set the Top-of-Form

---

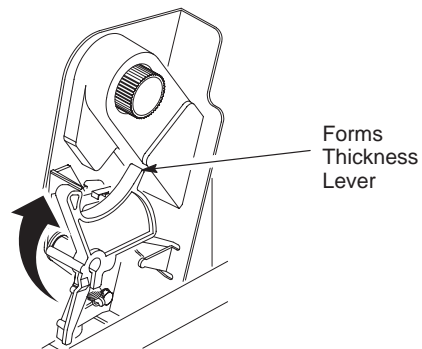

**Figure 2–34. Raising the Forms Thickness Lever**

1. Raise the forms thickness lever as far as it will go. The “CLOSE PLATEN” message will appear on the operator panel. Press any key on the operator panel to silence the alarm. (See Figure 2–34.)

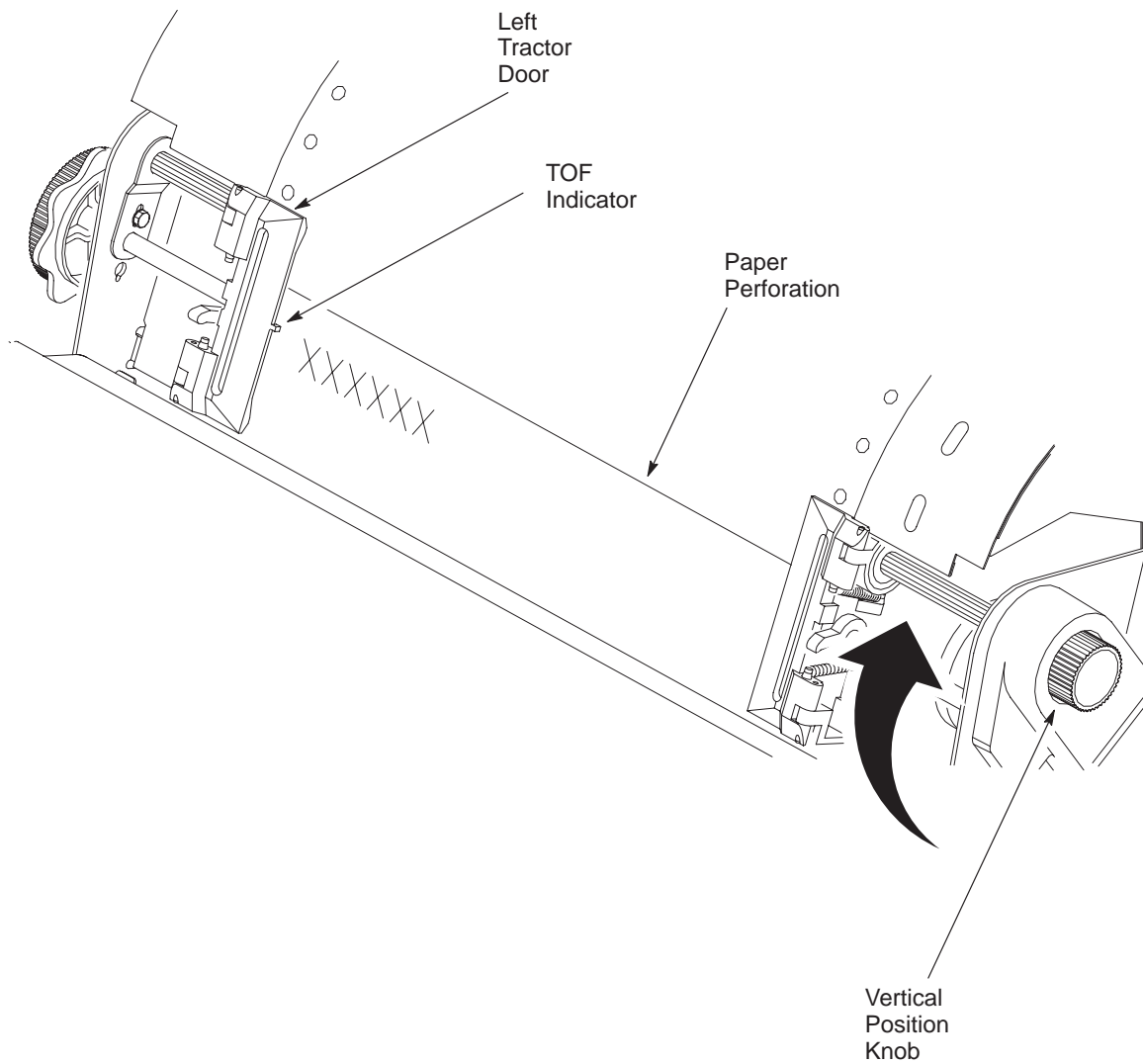

**Figure 2–35. TOF Indicator**

2. Locate the TOF indicator. It is the small tab located on the left tractor door. (See Figure 2–35.)
3. Turn the vertical position knob up or down to align the top of the first print line with the TOF indicator. (See Figure 2–35.)

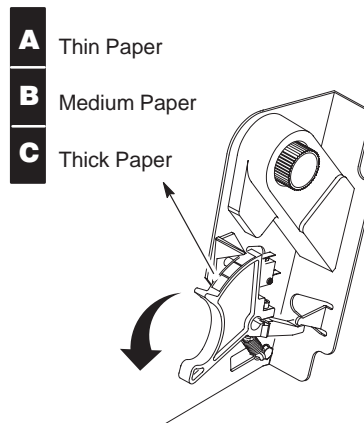

**Figure 2–36. The Forms Thickness Scale**

4. Lower the forms thickness lever. (The CLOSE PLATEN fault clears automatically.) Set it to match the paper thickness. If you are using single-part forms, set the forms thickness lever so that “A” is next to the indicator (refer to note on shuttle cover). (See Figure 2–36.)

**NOTE:** Do not set the forms thickness lever too tightly; excessive friction can cause paper jams, ribbon jams with potential for ribbon damage, smeared ink, or wavy print.

5. Press **Set Top of Form**. The paper moves downward to the top-of-form print position.
6. Continue with the next procedure to test the printer.

## Test the Printer

---

To run an initial printer test, print the current configuration page. Go to Chapter 3, “Printing the Current Configuration,” page 3–8, for instructions on printing the current configuration page.

On the configuration printout, examine the print quality of the characters. They should be fully formed and of uniform density. If text characters do not appear correctly formed or if the test does not run, contact your IBM service representative.

The printer is now ready for configuration. Refer to Chapter 3, “Configuring the Printer,” for more information.

# 3

## Configuring the Printer

### Chapter Contents

---

Overview .....	3-2
The Configurations .....	3-2
Active versus Saved Configurations .....	3-3
The Configuration Main Menu .....	3-4
Using the Operator Panel .....	3-6
Program Mode .....	3-7
Unlocking the Program Mode .....	3-7
Locking the Program Mode .....	3-7
Entering Program Mode .....	3-7
Printing the Current Configuration .....	3-8
Factory Default Configuration Values .....	3-11
Changing Parameters .....	3-18
Saving Your Configuration in a Custom Set .....	3-20
Loading Custom Sets or Factory Default Values .....	3-23
Changing the Power On Configuration .....	3-25

### IMPORTANT

**Configuration directly affects printer operation. Do not try to change the configuration of your printer until you are thoroughly familiar with the procedures in this chapter.**

In order to print data, the printer must respond correctly to signals and commands received from the host computer. Configuration is the process of matching the printer's operating characteristics to those of the host computer and to specific tasks, such as printing labels, or printing on different sizes of paper. The characteristics that define the printer's response to signals and commands received from the host computer are called configuration parameters.

You can configure the printer by pressing operator panel keys or by sending control codes from the host computer. This chapter explains how to use the operator panel to change individual parameters and save them as a custom configuration.

Operator panel keys are described in the *6400 Operator's Guide*.

Your programmer's reference manuals provide information about control codes.

## The Configurations

A configuration consists of a group of parameters, such as line spacing, forms length, etc. Your printer contains the following configurations:

- Four preloaded configurations that have been customized for printer setup. Refer to page 3–10 for a description of these configurations.
- The factory default configuration. It can be loaded, but it cannot be altered. A list of all the parameters and their values begins on page 3–11.
- Four configurations that you can customize for unique print job requirements. Page 3–18 explains how to create customized configurations.



## Active versus Saved Configurations

When you change a parameter value, it is active as long as the printer is on or until it is changed again. This is true whether you use the operator panel or send a control code from the host. Parameter values defined by control codes override the active operator panel parameters when the printer is using any of the parallel or serial interfaces. For example, if you set the line spacing to 6 lpi with the operator panel, and application software later changes this to 8 lpi with a control code, the control code setting overrides the operator panel setting. When the printer is using either the coax or twinax interface, parameter values defined by control codes may or may not override panel parameters, depending on the setting of the OVERRIDE HOST option. (See pages 4–24 and 4–32 for more information.) The following parameters are overridden when set by the host if the Coax interface is enabled with override host option:

- Characters per inch (cpi)
- Lines per inch (lpi)
- Forms width
- Forms length

Using the operator panel, you can save the parameters as a customized configuration that is stored in non-volatile random access memory (NVRAM). A saved configuration is *not* lost when you power off the printer.

**NOTE:** Saved configurations are also referred to as “custom sets.”

**NOTE:** For Coax/Twix (including IPDS), when switching between coax or twinax, a soft reset is performed. The soft reset reloads the power up configuration values except for the emulation and interface values. All other configuration values are taken from the power on custom set, not the factory default custom set.

There are no control codes that allow you to save a parameter in NVRAM. However, you can save a configuration defined partially by control codes and store it in NVRAM using the operator panel.

## The Configuration Main Menu

---

Figure 3–1 shows an overview of the printer configuration menus. The pages that follow describe how to enter program mode, print the current configuration, change configuration parameters, and save and load custom sets.

For specific configuration menu options and their descriptions, refer to Chapter 4, “Configuration Menus.”

**NOTE:** The menus that are displayed from the operator panel are determined by the installed features. For example, if you ordered the IPDS feature, then the IPDS menu would appear on the operator panel. If the IPDS feature is not installed, then the IPDS menu will not appear on the operator panel.

In this manual, the Coax and Twinax menus related to the Coax/Twinax feature are documented in Chapter 3, “Configuring the Printer,” and Chapter 4, “Configuration Menus,” because many customers order this feature at the factory. The operation of the Multi-Platform Interface Coax/Twinax feature is documented in the *Coax/Twinax Multi-Platform Interface Option Installation and Operation Guide*.

The menus for the IPDS, Code V, and IGP features are documented in Appendix D: “Code V, IGP, and IPDS Menus.”

Each feature is shipped with a document that describes the feature in detail. For more information about these documents, see the “Related Documents” section that begins on page 1–3.

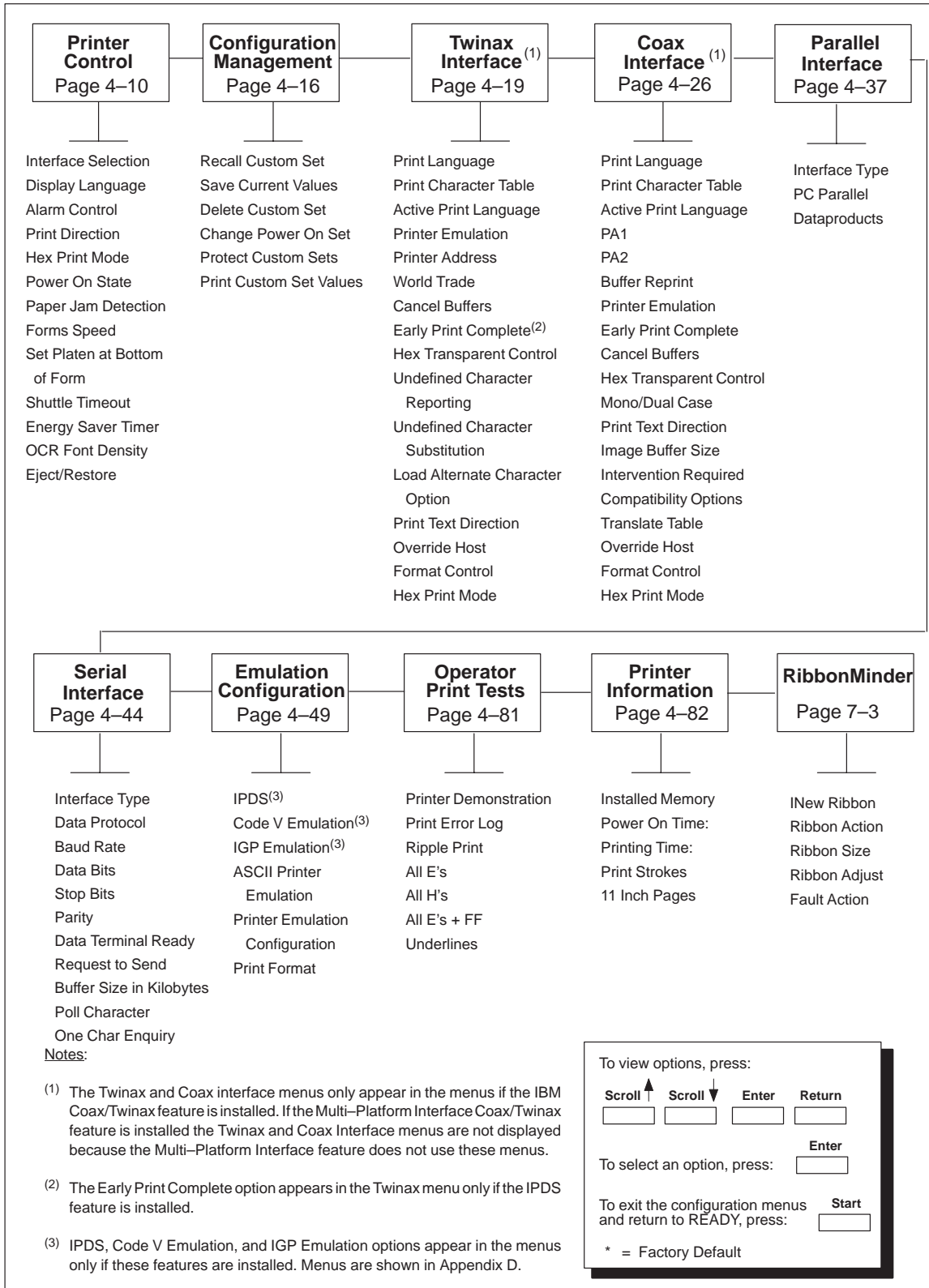

**Figure 3–1. Configuration Main Menu**

## Using the Operator Panel

---

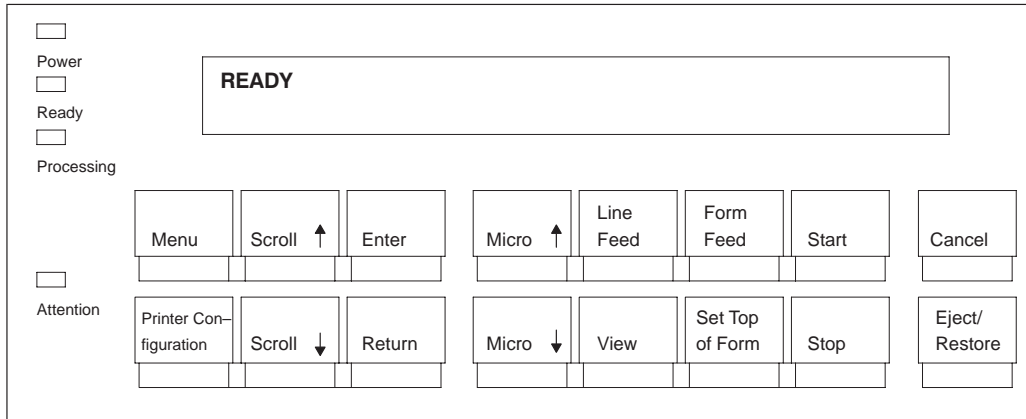

**Figure 3–2. The Operator Panel**

The operator panel is shown above. During the configuration process, you will use the **Scroll↑**, **Scroll↓**, **Enter**, and **Return** keys on the operator panel to access configuration settings and diagnostic tests via the configuration menus. As you access menus and options, menu names and option values appear on the operator panel message display (sometimes referred to as LCD, or Liquid Crystal Display).

This chapter provides numerous examples of how to use the operator panel keys and indicator message display to configure the printer. The operator panel key functions are described in detail in your *6400 Operator's Guide*.

## Program Mode

---

The printer is in Program mode whenever the configuration menus and option values are displayed on the operator panel message display. Program mode is either locked or unlocked. In order to select new configuration values, you must unlock Program mode. In order to prevent accidental changing of the configuration settings, you may lock Program mode.

### Unlocking the Program Mode

Program mode must be unlocked in order to use the operator panel to change the configuration settings. When Program mode is unlocked, pressing the **Enter** key selects configuration values as the active values, that is, places them into printer NVRAM. An asterisk (\*) after a displayed setting shows it is entered into memory.

Press the **Scroll**↑ + **Scroll**↓ keys at the same time to unlock Program mode. The following message will appear briefly:

OPERATOR MENU  
UNLOCKED

### Locking the Program Mode

When Program mode is locked, you cannot use the operator panel to change the configuration settings. However, you can still select the configuration menus and view the current configuration settings.

Press the **Scroll**↑ + **Scroll**↓ keys at the same time to lock Program mode. The following message will appear briefly:

OPERATOR MENU  
LOCKED

### Entering Program Mode









To place the printer in Program mode, press the **Menu** key.

## Printing the Current Configuration

---

Before you begin changing parameter values for the printer, you may wish to print out a record of the current configuration, including any active values that you have recently modified. If you have not changed any parameter settings, the current configuration is the same as the factory default configuration.

There are two methods for printing the current configuration: the first method is to press the Printer Configuration key, as shown in the following procedure.

Step	Key	Result	Notes
1.	Make sure the printer is on.		
2.	Press: 		The printer must be in NOT READY mode to print the configuration.
3.			You are prompted to press the <b>Start</b> key before the configuration prints.
4.			Indicates that the configuration has printed. Date and store the printout in a safe place. You may also want to label the printout (e.g. "Configuration for 2-up Labels").
5.			The printer is READY for normal operation.

The second method for printing the current configuration, as well as several other configurations, is to use the Print Custom Set Values menu option, shown on the following page.

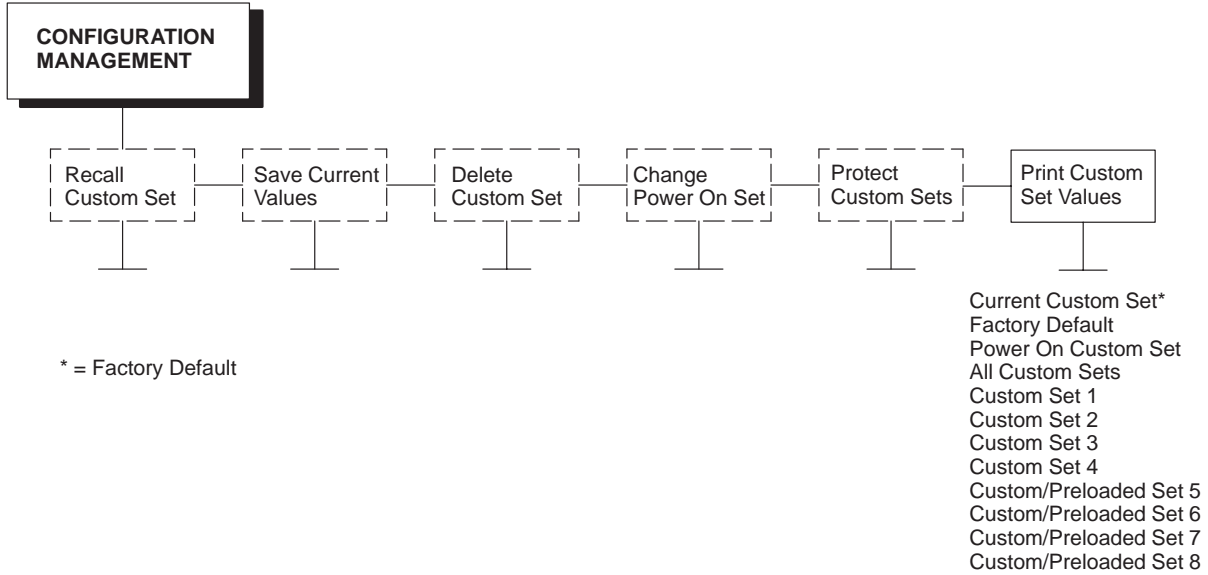

The Print Custom Set Values option on the Configuration Management menu allows you to print any or all of the configurations shown above. The default setting, “Current Custom Set,” will print the same information as pressing the Printer Configuration key. The Current Custom Set is the same as the Factory Default configuration until you begin modifying the printer configuration.

Unless it is a custom/preloaded set, a custom set does not exist until you save configuration parameters to it. You must define and save a custom set before you can print it.

Custom/Preloaded Sets 5–8 contain configuration sets that assist with the installation and configuration of this printer. These sets are preloaded at the factory. If these sets are not used, you can delete them and create new custom sets. For example, Custom/Preloaded Set 8 is preconfigured for the Multi-Platform Coax/Twinax Feature; but if you do not intend to use this feature, you can delete Custom/Preloaded Set 8 or overwrite it with a new set of configuration values.

Following is a brief description of Custom/Preloaded Sets 5–8:

- Custom/Preloaded Set 5 is used when configuring this printer to function like a Printronix printer. This custom set contains ASCII emulations used by Printronix compatible printers along with initial defaults (Overstrike, Auto LF, etc.). The initial ASCII default emulation is P-Series which may need to be altered for P-Series XQ or Serial Matrix in some applications. For more information, refer to the Configuration Utility Diskette shipped with this printer, or the *6400 ASCII Programmer's Reference Manual*.
- Custom/Preloaded Set 6 contains the default settings for an ASCII printer using a set of Epson and Proprinter default values. This could be useful when the printer has the IBM Coax/Twinax feature installed, but is sometimes run as an ASCII printer. Refer to the *6400 ASCII Programmer's Reference Manual* for more information.
- Custom/Preloaded Set 7 contains default settings for a Twinax printer without IPDS. This could be useful when this printer contains the IPDS feature, but is occasionally used as a non-IPDS printer. Refer to the *6400 IPDS Programmer's Reference Manual* or the *6400 Coax/Twinax Programmer's Reference Manual* for more information.
- Custom/Preloaded Set 8 is used when the optional Multi-Platform Interface Coax/Twinax feature is installed. Refer to the *Coax/Twinax Multi-Platform Feature Installation and Operation Guide* for more information on this custom set.

The other options will only be useful once you have modified and saved the printer's configuration parameter settings.

The Power On Custom Set is defined by the "Change Power On Set" option.

Custom Sets 1 through 8 are defined by the "Save Current Values" option.

These options are described in detail under the Configuration Management Menu description starting on page 4–17.



## Factory Default Configuration Values

---

The factory default values are permanently stored as a configuration. They cannot be modified or erased. The parameters which display depend on which interface and emulation is installed. The default values for optional features (IPDS, IGP and Code V) are provided in Appendix D.

Below is a representative factory default configuration based on the twinax interface. Your factory default configuration will depend on the features installed in your printer.

### CURRENT CONFIGURATION

#### IBM Printer Configuration

Base Coax/Twinax Version 2.01C  
IGP – Printronix Emulation Version 2.01B  
Base Line Printer+ Version 2.01C  
DC V2.01B 28–Oct–96 #158100  
EC V1.06D 23–Oct–96 #15802  
BOOT/CMX V1.04A 31–Oct–86 #158070  
SHUTTLE TYPE 475  
FLASH 2 MB  
DRAM 3 MB  
SECURITY PAL 154140–017  
CONFIGURATION CODE PC02FF

### PRINTER CONTROL

Interface Selection	Twinax
Display Language	English
Alarm Control	Alarm Enabled
Print Direction	Bidirectional
Hex Print Mode	Disable
Power On State	Ready
Paper Jam Detection	Enable
Forms Speed	Normal Speed
Set Platen at Bottom of Form	Disable
Shuttle Timeout	5 Seconds
Energy Saver Timer	15 Minutes
OCR Font Density	120 Dots per inch
Eject/Restore	Standard <sup>(5)</sup>

### CONFIGURATION MANAGEMENT

Recall Custom Set	Custom Set 1
Save Current Values	1
Delete Custom Set	1
Change Power On Set	Factory Default
Protect Custom Sets	Disable
Print Custom Set Values	Current Custom Set

### TWINAX INTERFACE <sup>(1)</sup>

Print Language	
Standard Print Language	0037 English (USA/Canada)

Alternate Print Language	English US
Print Character Table	
Active Print Language	Standard Print Language
Printer Emulation	4234-2
Printer Address	Address 1
World Trade	Standard Character Set
Cancel Buffers	Enable
Early Print Complete	Disable <sup>(6)</sup>
Hex Transparent Control	Set 1 <%>
Undefined Character Reporting	Enable
Undefined Character Substitution	60
Load Alternate Character Option	Enable
Print Text Direction	Control By Host
Override Host	Disable
Format Control	Disable
Hex Print Mode	Disable
COAX INTERFACE <sup>(1)</sup>	
Print Language	
Standard Print Language	0037 English (USA/Canada)
Alternate Print Language	English US
Print Character Table	
Active Print Language	Standard Print Language
PA1	
PA2	
Buffer Reprint	
Printer Emulation	4234
Early Print Complete	Disable
Cancel Buffers	Enable
Hex Transparent Control	Set 1 <%>
Mono/Dual Case	Dual Case
Print Text Direction	Control By Host
Image Buffer Size	4K
Intervention Required	Send to Host
Compatibility Options	
Compatibility Option 1	On
Compatibility Option 2	On
Compatibility Option 3	Off
Compatibility Option 4	On
Compatibility Option 5	Off
Compatibility Option 6	Off
Compatibility Option 7	Off
Compatibility Option 8	Off
Compatibility Option 9	On
Compatibility Option 10	Off
Translate Table	Default
Override Host	Disable
Format Control	Disable
Hex Print Mode	Disable
PARALLEL INTERFACE	
Interface Type	PC Parallel
PC Parallel	
Data Bit 8	Enable

Data Polarity	Standard
Strobe Polarity	Standard
Response Polarity	Standard
Busy on Strobe	Enable
Latch Data On	Leading Edge
Prime Signal	Enable
TOF Action at Prime Signal	Form Feed at Reset
Buffer Size in Kilobytes	1
Dataproducts	
Data Bit 8	Enable
PI Ignored	Enable
Data Polarity	Standard
Data Request Polarity	Standard
Strobe Polarity	Standard
SERIAL INTERFACE	
Interface Type	RS 232
Data Protocol	XON/XOFF
Baud Rate	9600 Baud
Data Bits	8
Stop Bits	1
Parity	None
Data Terminal Ready	READY and Buffer Not Full
Request to Send	READY and Buffer Not Full
Buffer Size in Kilobytes	1
Poll Character	00 Hex
One Char Enquiry	Disable
EMULATION CONFIGURATION	
IPDS <sup>(2)</sup>	
Override Host	Disable
Graphics Quality	Medium
Bar Code Quality	High
Image Quality	Low
IPDS Emulation Mode	4234
Code V Emulation <sup>(2)</sup>	
SFCC and Power On	
Select SFCC	5E
Power on ^X	Disable
Power on ^F	Disable
Power on ^PY	Disable
Lines Per Inch	6
Graphics Options	
Slashed Zero	Disable
Ignore Dots Value	Disable
Append Rotated	Disable
Truncate Off Page Alpha	Enable
True Vert 1/10	Disable
Absorb at ^PY	Absorb Motion
UPC Descenders	Enable
Rotate Character Size	Adjusted
Ignore Spaces	Disable
Midline PY	Disable
Dark Barcodes	Disable

Width Limit	Disable
Expanded Font	Scalable
IGP110 Compatibility	Disable
Error Handling	
Error Messages	Enable
Error Markers	Enable
Off Page Errors	Disable
Bar Code Errors	Enable
Character Filtering	
Ignore Characters	Disable
Select Character 1	0
Select Character 2	0
Data Bit 8	Enable
Font Set	0
PI Control	
Printer PI	Disable
Host PI	Disable
PI Slew Range	Enable
IGP Emulation <sup>(2)</sup>	
Define CR Code	CR = CR
Define LF Code	LF = LF
Auto LF	Disable
Select SFCC	7E
PI Slew Range	16
CR Edit	Disable
Select Font	0
Lines Per Inch	6 lines per inch
Mono/Dual Case	Dual case
Skip command prefix	Enable
Power on IGP	Enable
EXT Execute Copy	Disable
UPC Descenders	Enable
Compressed 17 CPI	Disable
Ignore Character	
Ignore Mode	Disable
Select Character	0
IGP100 Compatibility	Disable
Expanded Font	Scalable
Optimized Ratio	Disable
ASCII Printer Emulation	Proprinter III XL Emulation P-Series Emulation <sup>(3)</sup>
Printer Emulation Configuration	
Proprinter III XL Emulation	
Print Language	0437 PC Character Set
Alternate Character Set	PC Character Set 2
Define CR Code	CR = CR
Auto LF	Enable
Define LF Code	LF = LF
FF Valid at TOF	Enable
20 CPI Condensed	Enable
Epson Emulation	
Character Sets	Epson Set

Epson Print Language	ASCII (USA)
Define CR Code	CR = CR
Auto LF	Enable
Define LF Code	LF = LF
Printer Select	Disable
20 CPI Condensed	Enable
P-Series Emulation	
Character Sets	IBM PC
Print Language	
IBM PC	
Select Subset Primary	ASCII (USA)
Select Subset Extended	0437 PC Character Set
Multinational	ASCII (USA)
ECMA Latin 1	
Select Subset Primary	ASCII (USA)
Select Subset Extended	Multinational
DEC Multinational	ASCII (USA)
Control Code 6	8.0 LPI
Control Code 8	Elongated
Define CR Code	CR = CR
Auto LF	Disable
Overstrike	Enable
Define LF Code	LF = LF
Select SFCC	1
EVFU Select	Enable
Alternate Set 80-9F	Control Code
P Series XQ Emulation	
Control Code 6	8.0 LPI
Define CR Code	CR = CR
Auto LF	Disable
Define LF Code	LF = LF
Compressed Print	Char 01 SOH
Elong/Alt. Font	Elong=BS Font=SO
High Speed Print Mode	Char 02 STX
EVFU Select	Enable
Upper Case Select	Disable
Slew Relative	1 to 16 lines
Serial Matrix Emulation	
Character Sets	IBM PC
Print Language	
IBM PC	
Select Subset Primary	ASCII (USA)
Select Subset Extended	0437 PC Character Set
Multinational	ASCII (USA)
ECMA Latin 1	
Select Subset Primary	ASCII (USA)
Select Subset Extended	Multinational
DEC Multinational	ASCII (USA)
Control Code 06	8.0 LPI
Define CR Code	CR = CR
Auto LF	Enable
Overstrike	Enable

Define LF Code	LF = LF
Printer Select	Disable
Alternate Set 80–9F	Control Code
Print Format <sup>(7)</sup>	
Characters Per Inch	10.0 Characters Per Inch
Lines Per Inch	6.0 Lines Per Inch
Forms Width <sup>(7)</sup>	
Forms Width in inches	13.6 inches
	13.2 inches <sup>(4)</sup>
Forms Width in MM	345.4 MM
	335.3 MM <sup>(4)</sup>
Forms Width in Characters	136 Characters
	132 Characters <sup>(4)</sup>
Forms Length <sup>(7)</sup>	
Forms Length in inches	11.0 inches
Forms Length in mm	279.4 mm
Forms Length in lines	66 lines
Print Quality	DP Quality
Print Character Table	
Print Attributes	
Proportional Spacing	Disable
Italic Print	Disable
Slashed Zero	Disable
Margins <sup>(8)</sup>	
Left Margin	0 Characters
Right Margin	0 Characters
Bottom Margin	0 Lines
Perforation Skip	Disable
Reset Command	Load Factory
Operator Print Tests	Printer Demonstration
Printer Information	
Installed Memory	3 MB
Power On Time:	XXX.X Hours
Printing Time:	XX Hours
Print Strokes	XXXXXXX
11 Inch Pages	XXXX
RibbonMinder	
New Ribbon	
Ribbon Action	Disable
Ribbon Size	100 Yards
Ribbon Adjust	0
Fault Action	New Ribbon

Notes:

(1) Twinax and Coax Interface only appear in the menus if these features are installed. Menus are shown in Chapter 4. If the Multi-Platform Interface Coax/Twinax feature is installed the Twinax and Coax Interface menus are not displayed because the Multi-Platform Interface Coax/Twinax feature does not use these menus.

(2) IPDS, IGP and Code V Emulations only appear in the menus if these features are installed. Menus are shown in Appendix D.

- (3) P-Series Emulation should be selected as the ASCII Printer Emulation when Code V and IGP emulation features are installed.
- (4) Default forms width values when P-Series, Coax/Twinax, IGP or Code V are installed.
- (5) Cabinet and Pedestal Models.
- (6) IPDS only.
- (7) For Coax/Twinax, forms width is measured in characters and forms length is measured in lines.
- (8) For Coax/Twinax, bottom margin is available.



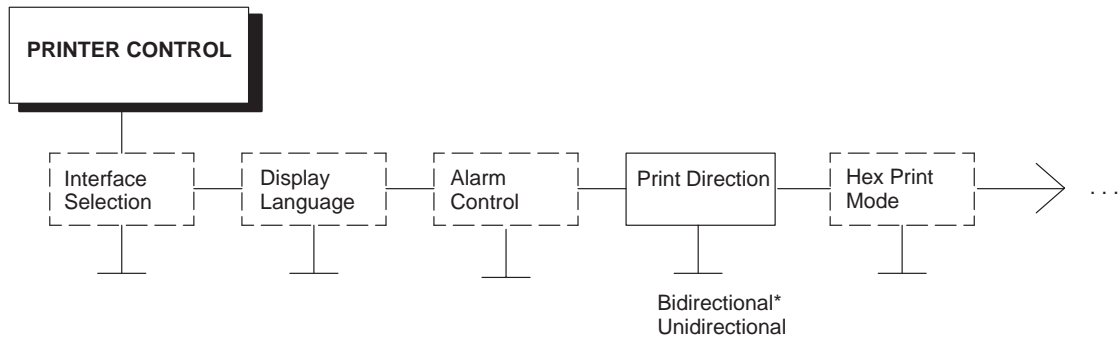



## Changing Parameters





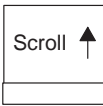
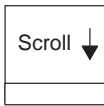







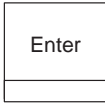

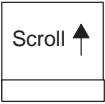

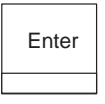

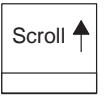
\* = Factory Default

The following procedure shows you how to change a configuration setting. Changing the Print Direction from the factory default setting **BIDIRECTIONAL** to the setting **UNIDIRECTIONAL** is provided as an example. Print Direction is one of the Printer Control menu options. The procedure is similar for other configuration changes. Use these basic guidelines to navigate the configuration menus and change other parameters.

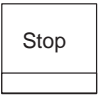
**NOTE:** You can press **Start** at any time to exit the configuration menu.

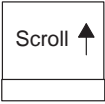
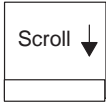
Step	Key	Result	Notes
1.	Determine which parameters you want to change, and what their new values should be. (In this example, we are changing the value of the PRINT DIRECTION parameter from “BIDIRECTIONAL” to “UNIDIRECTIONAL.”)		
2.	Press: 		Places the printer in NOT READY mode before entering the operator menus.
3.	 + 		Unlocks the Operator Menu, which allows you to make configuration changes.
4.			Displays the first Configuration Main Menu option, PRINTER CONTROL.



Step	Key	Result	Notes
5.			Moves into the PRINTER CONTROL menu.
6.	 UNTIL		Moves to the PRINT DIRECTION parameter.
7.			Moves into the PRINT DIRECTION menu. The asterisk (*) shows that this is the active value.
8.			Moves to the next available option, the UNIDIRECTIONAL option.
9.			Selects the displayed value. An asterisk (*) appears, indicating that this choice is now the active value.
10.	Continue this pattern to make other changes, using the information in this chapter.		
11.	The configuration you have selected is now the “active” value until you power off the printer. To save changes so that they will remain when the printer is reset or powered back on, see “Saving Your Configuration in a Custom Set” on page 3–20. If you want to use—but not save—these settings, continue to the next step.		
12.			Returns the printer to the NOT READY mode.
13.	 + 		Relocks Program mode and the Operator Menu.
14.			Places the printer in READY mode, prepared for normal operation.

## Saving Your Configuration in a Custom Set

---

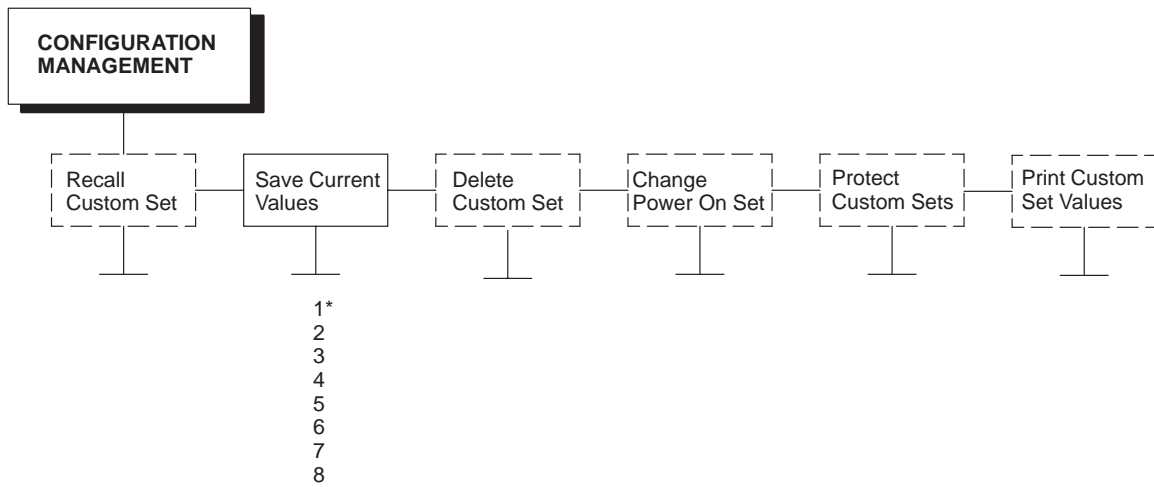

\* = Factory Default

Once you have changed all of the necessary parameters, it is recommended you save them as a configuration that can be stored and loaded later for future use. You can save your configurations to meet different print job requirements.











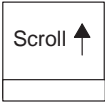
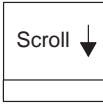

The saved configurations (called custom sets) are stored in NVRAM—they will not be lost if you power off the printer.



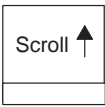
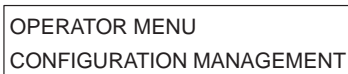

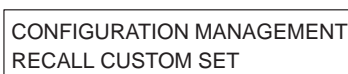
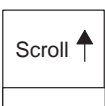
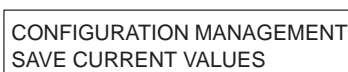

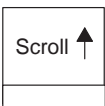

Later, you can load one of the configurations for a specific print job. This eliminates the need to change settings (CPI, LPI, etc.) for each new job. See page 3–23 about loading configurations.

You may want to print records of your configurations (page 3–8) and store them in a safe place, such as inside the printer cabinet.

If you do not save your configuration before you power off the printer, all of the new parameter values that have not been saved to NVRAM will be erased. When you power the printer on again, the power-on configuration will load. If no configuration has been designated as the power-on configuration, the factory configuration will load.

**NOTE:** To avoid overwriting an existing custom set, the Protect Custom Sets parameter must be set to ENABLE. See page 4–18 for details.

Step	Key	Result	Notes
1. Press:			Places the printer in NOT READY mode.
2.	 + 		Unlocks the Operator Menu, which allows you to save configuration changes.
3.			Displays the PRINTER CONTROL option on the Configuration Main Menu.
4.	 UNTIL		Moves to the Configuration Management menu option.
5.			Selects the CONFIGURATION MANAGEMENT menu. The RECALL CUSTOM SET option appears.
6.	 UNTIL		Moves to the SAVE CURRENT VALUES option.
7.			Selects the SAVE CURRENT VALUES menu.
8.	 UNTIL		Scrolls through list of custom sets 1–8.

Step	Key	Result	Notes
9.			Selects the SAVE CURRENT VALUES option. The message “SAVING CONFIGURATION” appears briefly.
10.			Returns the printer to the NOT READY mode.
11.	 + 		Relocks Program mode and the Operator Menu.
12.			Places the printer in READY mode, prepared for normal operation.
<b>13.</b> It is recommended you make a printout of your current configuration, as described on page 3–8.			

## Loading Custom Sets or Factory Default Values

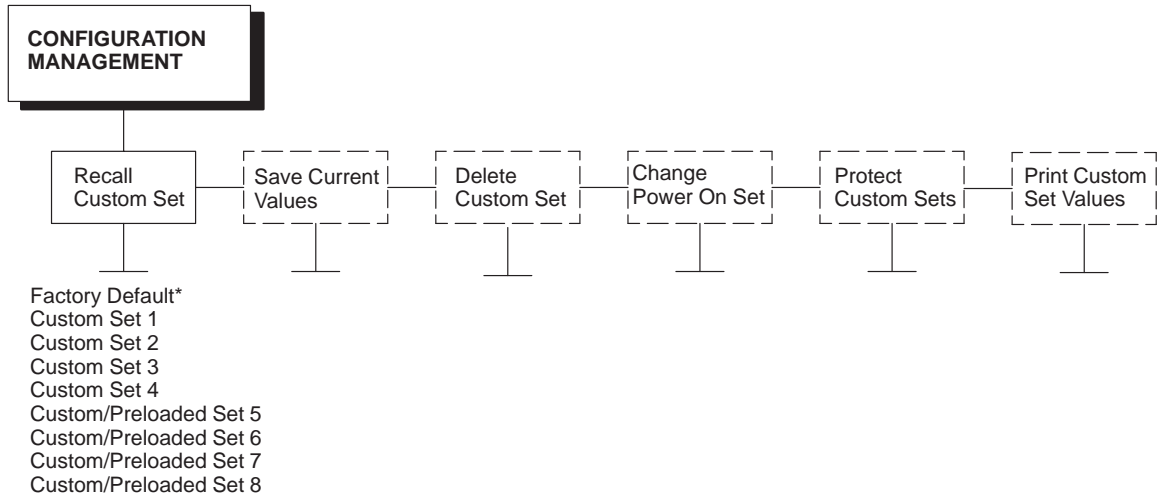











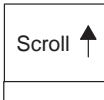
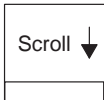





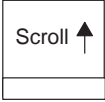



\* = Factory Default

You can load any of the custom set configurations or the factory default configuration. (Factory default parameters are shown starting on page 3–11.)

The loaded configuration remains active as long as the printer is on. The following procedure shows how to load factory defaults to the printer.

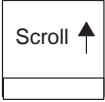
If you power off the printer, the power-on configuration will load the next time the printer is powered on. Page 3–25 explains how to select the power-on configuration.

Step	Key	Result	Notes
1. Press:			Places the printer in NOT READY mode.
2.	 + 		Unlocks the Operator Menu, which allows you to load a configuration.
3.			Displays the first Configuration Main Menu option, PRINTER CONTROL.

Step	Key	Result	Notes
4.	 UNTIL		Moves from the Configuration Main Menu option to the CONFIGURATION MANAGEMENT menu.
5.			Moves to the RECALL CUSTOM SET option.
6.			Moves forward to the FACTORY DEFAULT parameter for the RECALL CUSTOM SET option.
7.			Loads the set of Factory Default values. The message “LOADING SAVED CONFIGURATION” appears briefly.
8.			Returns the printer to NOT READY mode.
9.	 + 		Locks Program mode and the Operator Menu.
10.			Places the printer in READY mode, with the Factory Default values loaded.

## Changing the Power On Configuration

---

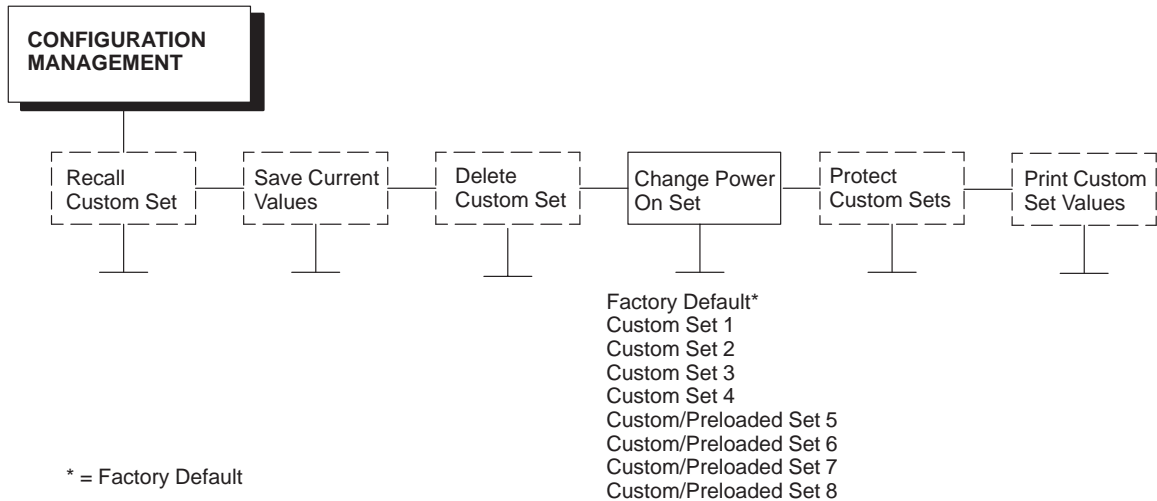









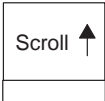
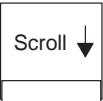

When you power on the printer for the first time, it loads the factory default configuration. If you power the printer off and then back on, the printer will load the designated power-on configuration (which is set to Factory Default by default), not the last saved configuration.

The Change Power On Set option allows you to select a custom set of configuration values as the power-on configuration. The example on the following page shows how to select Custom Set 1 as the power-on configuration.

**NOTE:** Be sure you define and save a custom set before attempting to use it as the Power On Custom Set. Otherwise, the following operator panel message appears and factory defaults are defined as the Power On Custom Set:

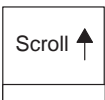
042 CUSTOM SET DOES NOT EXIST  
SAVE FIRST

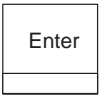
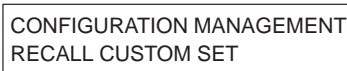
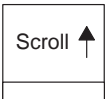
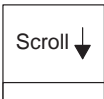
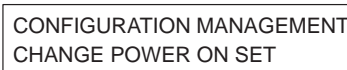
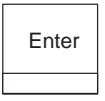
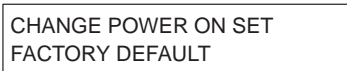
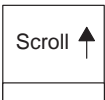
For example, if you attempt to change the Power On Custom Set from Custom Set 1 to Custom Set 4, and if Custom Set 4 does not exist, the currently loaded custom set becomes the Power On Custom Set.

Step	Key	Result	Notes
1.	Press: 		Places the printer in NOT READY mode before changing the configuration.
2.	 + 		Unlocks Program mode and the Operator Menu, which allows you to load a configuration.
3.			Displays the first Configuration Main Menu option, PRINTER CONTROL.
4.	 UNTIL		Moves from the Configuration Main Menu to the CONFIGURATION MANAGEMENT menu.
5.			Moves forward to the RECALL CUSTOM SET parameter.
6.	 OR 		Moves to the CHANGE POWER ON SET parameter.
7.			Displays the first POWER ON SET option, FACTORY DEFAULT.
8.			Displays CUSTOM SET 1 as the POWER ON SET option value.



Step	Key	Result	Notes
9.	<div style="border: 1px solid black; padding: 2px; text-align: center;">Enter</div>	<div style="border: 1px solid black; padding: 2px;">CHANGE POWER ON SET CUSTOM SET 1*</div>	An * appears after the change is complete.
10.	<div style="border: 1px solid black; padding: 2px; text-align: center;">Stop</div>	<div style="border: 1px solid black; padding: 2px;">NOT READY</div>	Returns the printer to NOT READY mode.
11.	<div style="display: flex; align-items: center; gap: 10px;"> <div style="border: 1px solid black; padding: 2px; text-align: center;">Scroll ↑</div> <span style="font-size: 24px;">+</span> <div style="border: 1px solid black; padding: 2px; text-align: center;">Scroll ↓</div> </div>	<div style="border: 1px solid black; padding: 2px;">OPERATOR MENU LOCKED</div>	Locks Program mode and the Operator Menu.
12.	<div style="border: 1px solid black; padding: 2px; text-align: center;">Start</div>	<div style="border: 1px solid black; padding: 2px;">READY</div>	Places the printer in READY mode.



# 4 Configuration Menus

## Chapter Contents

---

Overview .....	4-7
How to Read Configuration Menus .....	4-7
The Configuration Main Menu .....	4-9
Printer Control Menu .....	4-10
Interface Selection .....	4-11
Display Language .....	4-11
Alarm Control .....	4-11
Print Direction .....	4-11
Hex Print Mode .....	4-12
Power On State .....	4-12
Paper Jam Detection .....	4-12
Forms Speed .....	4-12
Set Platen at Bottom of Form .....	4-13
Shuttle Timeout .....	4-13
Energy Saver Timer .....	4-13
OCR Font Density .....	4-14
Eject/Restore .....	4-14
Configuration Management Menu .....	4-16
Recall Custom Set .....	4-17
Save Current Values .....	4-18
Delete Custom Set .....	4-18
Change Power On Set .....	4-18
Protect Custom Sets .....	4-18
Print Custom Set Values .....	4-18
Twinax Interface Menu .....	4-19
Print Language .....	4-21
Print Character Table .....	4-21

Active Print Language .....	4-21
Printer Emulation .....	4-21
Printer Address .....	4-22
World Trade (5225 Only) .....	4-22
Cancel Buffers .....	4-22
Hex Transparent Control .....	4-23
Undefined Character Reporting .....	4-23
Undefined Character Substitution .....	4-23
Load Alternate Character Option .....	4-24
Print Text Direction .....	4-24
Override Host .....	4-24
Format Control .....	4-25
Hex Print Mode .....	4-25
Coax Interface Menu .....	4-26
Print Language .....	4-28
Print Character Table .....	4-28
Active Print Language .....	4-28
PA1 .....	4-28
PA2 .....	4-29
Buffer Reprint .....	4-29
Printer Emulation .....	4-29
Early Print Complete .....	4-29
Cancel Buffers .....	4-30
Hex Transparent Control .....	4-30
Mono/Dual Case .....	4-30
Print Text Direction .....	4-31
Image Buffer Size .....	4-31
Intervention Required .....	4-31
Translate Table .....	4-31
Override Host .....	4-32
Format Control .....	4-32
Hex Print Mode .....	4-32
Compatibility Options Menu (Coax Only) .....	4-33
Compatibility Option 1: Carriage Return at MPP+1 .....	4-34

Compatibility Option 2: New Line at MPP+1 .....	4-34
Compatibility Option 3: Position After Form Feed (4234 only) .....	4-34
Compatibility Option 4: Form Feed at End of Print Buffer .....	4-34
Compatibility Option 5: Null Supression .....	4-35
Compatibility Option 6: Form Feed Command Position .....	4-35
Compatibility Option 7: Automatic Form Feed at End of Print Buffer .....	4-35
Compatibility Option 8: Automatic FF After Operator-Initiated Copy .....	4-36
Compatibility Option 9: CR, EM, and NL (3287 only) .....	4-36
Compatibility Option 10: Bottom Margin (SCS data stream only) ....	4-36
Parallel Interface Menu .....	4-37
Interface Type .....	4-37
PC Parallel Menu .....	4-38
Data Bit 8 .....	4-39
Data Polarity .....	4-39
Strobe Polarity .....	4-39
Response Polarity .....	4-39
Busy on Strobe .....	4-39
Latch Data On .....	4-40
Prime Signal .....	4-40
TOF Action at Prime Signal .....	4-40
Buffer Size in Kilobytes .....	4-40
Dataproducts Menu .....	4-41
Data Bit 8 .....	4-42
PI Ignored .....	4-42
Data Polarity .....	4-42
Data Request Polarity .....	4-42
Strobe Polarity .....	4-42
IEEE 1284 .....	4-43
Serial Interface Menu .....	4-44
Interface Type .....	4-45
Data Protocol .....	4-45
Baud Rate .....	4-45

Data Bits .....	4-46
Stop Bits .....	4-46
Parity .....	4-46
Data Terminal Ready .....	4-46
Request to Send .....	4-47
Buffer Size in Kilobytes .....	4-47
Emulation Configuration Menu .....	4-49
ASCII Printer Emulation .....	4-50
Printer Emulation Configuration .....	4-51
Print Format .....	4-51
Proprinter III XL Emulation Menu .....	4-52
Print Language .....	4-53
Alternate Character Set .....	4-53
Define CR Code .....	4-53
Auto LF .....	4-53
Define LF Code .....	4-54
FF Valid at TOF .....	4-54
20 CPI Condensed .....	4-54
Epson Emulation Menu .....	4-55
Character Sets .....	4-56
Epson Print Language .....	4-56
Define CR Code .....	4-56
Auto LF .....	4-56
Define LF Code .....	4-57
Printer Select .....	4-57
20 CPI Condensed .....	4-57
P-Series Emulation Menu .....	4-58
Character Sets .....	4-60
Print Language .....	4-60
Control Code 06 .....	4-61
Control Code 08 .....	4-61
Define CR Code .....	4-61
Auto LF .....	4-61
Overstrike .....	4-62

Define LF Code .....	4-62
Select SFCC .....	4-62
EVFU Select .....	4-62
Alternate Set 80-9F .....	4-63
P-Series XQ Emulation Menu .....	4-64
Control Code 06 .....	4-65
Define CR Code .....	4-65
Auto LF .....	4-65
Define LF Code .....	4-65
Compressed Print .....	4-66
Elong./Alt. Font .....	4-66
High Speed Print Mode .....	4-66
EVFU Select .....	4-66
Uppercase Select .....	4-67
Slew Relative .....	4-67
Serial Matrix Emulation Menu .....	4-68
Character Sets .....	4-70
Print Language .....	4-70
Control Code 06 .....	4-71
Define CR Code .....	4-71
Auto LF .....	4-71
Overstrike .....	4-71
Define LF Code .....	4-72
Printer Select .....	4-72
Alternate Select 80-9F .....	4-72
Print Format Menu .....	4-73
Characters Per Inch .....	4-74
Lines Per Inch .....	4-74
Forms Width .....	4-75
Forms Length .....	4-77
Print Quality .....	4-78
Print Character Table .....	4-78
Print Attributes .....	4-79
Margins .....	4-79
Perforation Skip .....	4-80
Reset Command .....	4-80

Operator Print Tests Menu .....	4-81
Printer Information Menu .....	4-82
RibbonMinder .....	4-83
New Ribbon .....	4-83
Ribbon Action .....	4-83
Ribbon Size .....	4-84
Ribbon Adjust .....	4-84
Fault Action .....	4-84



## Overview

---

This chapter describes the configuration menus. The Configuration Main Menu options and all of the submenu options are illustrated in menu diagrams and described in detail. For procedures showing how to enter Program mode, save, recall, and print configurations, refer to Chapter 3, “Configuring the Printer.”

Figure 4–1 on page 4–9 shows an overview of the configuration menus.

**NOTE:** The menus that are displayed from the operator panel are determined by the installed features. For example, if you ordered the IPDS feature, then the IPDS menu would appear on the operator panel. If the IPDS feature is not installed, then the IPDS menu will not appear on the operator panel.

In this manual, the Coax and Twinax menus for the Coax/Twinax feature are documented in Chapter 3, “Configuring the Printer,” and Chapter 4, “Configuration Menus,” because many customers order this feature at the factory. The Coax/Twinax interface for the Multi-Platform Interface Coax/Twinax feature is documented in the *6400 Coax/Twinax Multi-Platform Interface Option Installation and Operation Guide*.

The menus for the IPDS, Code V, and IGP are documented in Appendix D: Code V, IGP, and IPDS Menus.

Each feature is shipped with a document that describes the feature in detail. For more information about these documents, see the “Related Documents” section that begins on page 1–3.

### How to Read Configuration Menus

The configuration menu diagrams on the following pages show the structure of the configuration menus and the parameter options available in each menu. The diagrams list the menus and options in the order they appear when you use the operator panel to configure the printer. Factory default configuration values are indicated by an asterisk (\*).

Pressing the operator panel keys (**Enter**, **Return**, **Scroll**↑, and **Scroll**↓) allows you to move through the menus and select various choices for the options, as follows:

- The **Enter** key allows you to move down to a lower level in the menu structure, and to select an option value as the active value.
- The **Return** key moves you back up the menu structure.
- The **Scroll**↑ key moves forward through the options at a particular menu level.
- The **Scroll**↓ key moves backward through the options at a particular menu level.

These keys are summarized in a legend box at the lower right corner of each configuration menu diagram.

# The Configuration Main Menu

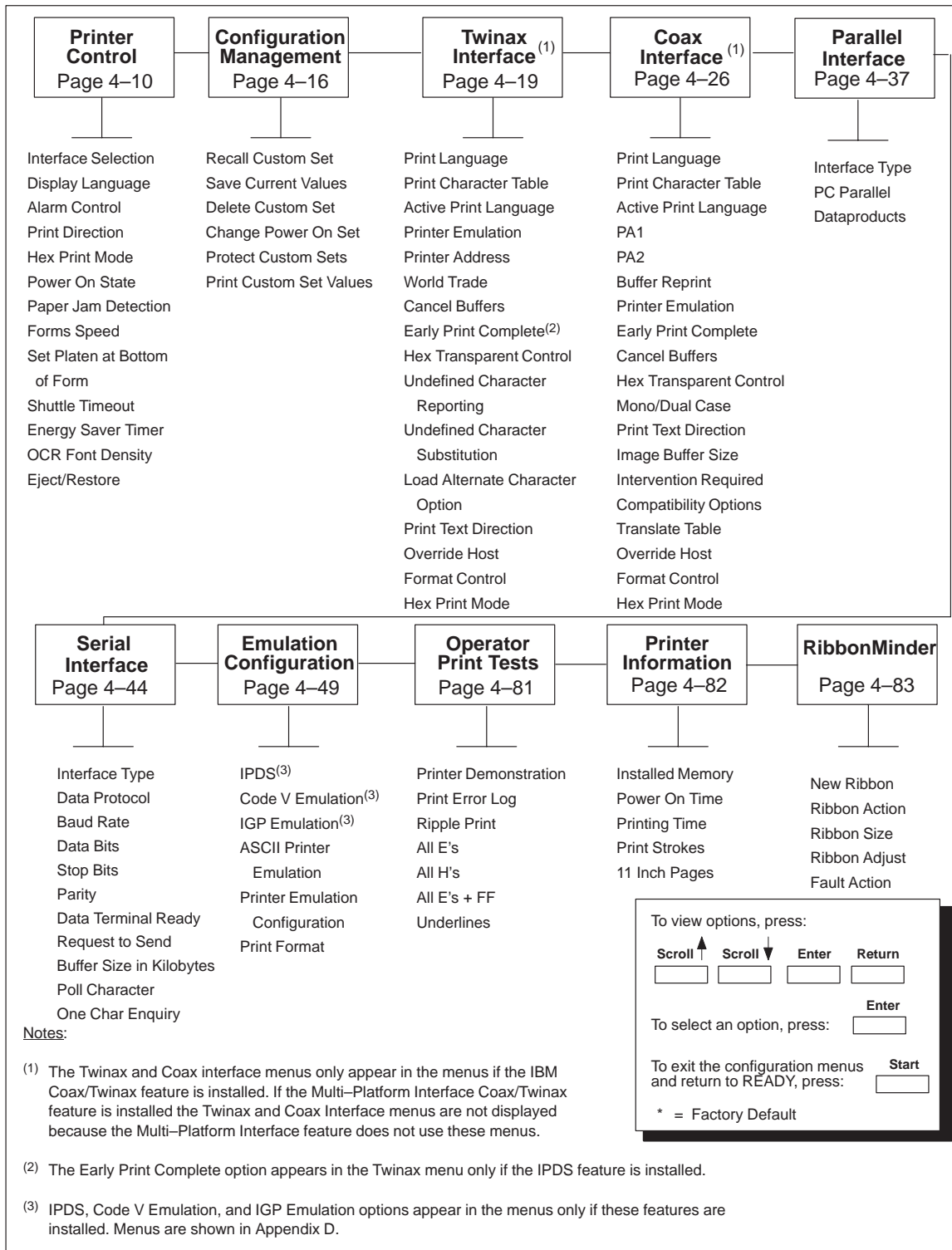
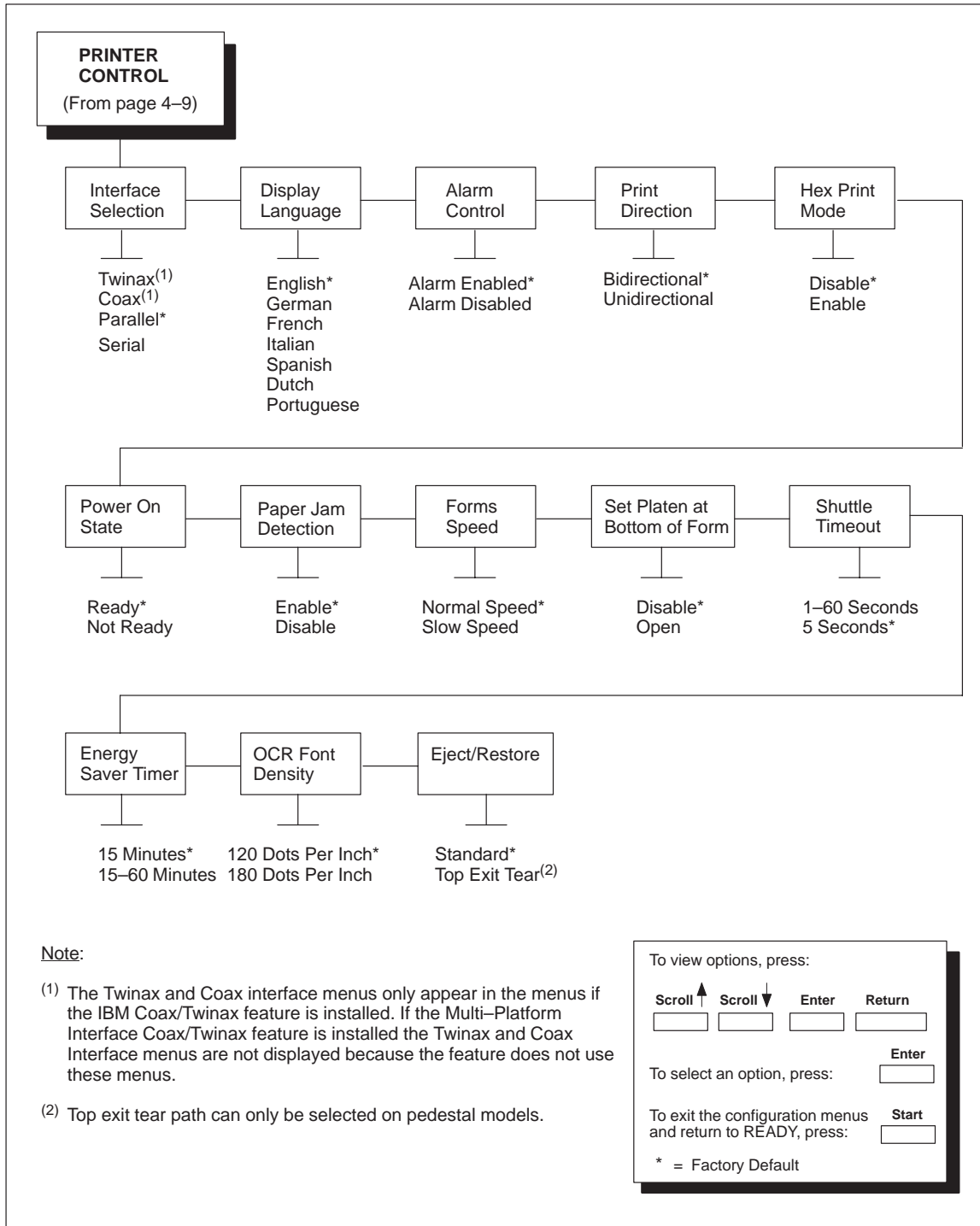

Figure 4-1. The Configuration Main Menu

# Printer Control Menu



**Figure 4-2. Printer Control Menu**

## Interface Selection

INTERFACE SELECTION enables or disables physical interfaces for attachment switching. If an interface is disabled, it is set offline and any data received will be ignored.

When coax or twinax are selected, a POR status is sent to the host.

**NOTE:** Only one interface can be enabled at a time. If the Multi-Platform Interface Coax/Twinax feature is installed, the feature provides automatic interface switching between parallel and either coax or twinax communications. Refer to the *Coax/Twinax Multi-Platform Interface Option Installation and Operation Guide* (S246-0149) for more information.

## Display Language

This parameter selects the language in which the operator panel messages will be displayed.

## Alarm Control

This parameter enables or disables the audible alarm. The audible alarm is used to signal problems such as when an end of forms occurs.

## Print Direction

The PRINT DIRECTION feature affects both print quality and printing speed. By setting this feature, you can configure the printer to print in both directions of the shuttle sweep (BIDIRECTIONAL), or to print in only one direction (UNIDIRECTIONAL).

You might want to use UNIDIRECTIONAL when printing bar codes, high quality text and graphics, or other printing that requires precise vertical alignment.

Although enabling this feature reduces print speed, it enhances the vertical alignment of dots and produces cleaner, sharper bar codes and text.

- BIDIRECTIONAL (the default) will print all data in both directions of the shuttle sweep. This choice produces higher printing speed.
- UNIDIRECTIONAL will print all data in only one direction of the shuttle sweep. This choice produces higher print quality.

## Hex Print Mode

A hex code printout (or hex dump) translates all incoming data to hexadecimal equivalents. A hex dump lists each ASCII data character received from the host computer, together with its corresponding two-digit hexadecimal code. Hex dumps can be used to troubleshoot some types of printer data reception problems.

Refer to page 6–10 to obtain a hex code printout.

**NOTE:** Printing in Hex Mode may alter print attributes set at the operator panel or by the host computer. These attributes may need to be reset after exiting Hex Print Mode.

## Power On State

This parameter allows you to configure the printer to power on in the READY or NOT READY mode.

## Paper Jam Detection

This parameter determines whether or not paper jam detection is active. When set to ENABLE (the default), paper jams are detected and when set to DISABLE, paper jam checking is disabled to prevent false errors.

### WARNING

**<2> When paper jam detection is disabled, the printer does not monitor paper motion. If a paper jam occurs, the printer ignores the condition and continues to print, possibly causing severe damage to the printer.**

## Forms Speed

FORMS SPEED affects the speed at which paper moves into the stacking area of the printer.

- NORMAL SPEED (the default) will slew and stack paper, such as single-sheet data processing paper, at maximum speed.
- SLOW SPEED causes the paper to stack at a slower pace. This ensures that forms, such as multiple-sheet (i.e. invoice), will stack more neatly.

## Set Platen at Bottom of Form

Some special forms have perforation areas that are thicker than the rest of the form. Enable this parameter when you are using this type of form. This parameter, when open is selected, allows the platen to open and close when perforations thicker than the rest of a form move across the platen.

In order to retain print quality with this type of form, set the position of the first and last print lines to avoid printing where paper thickness occurs (before and after the perforation). See Forms Length and Perforation Skip for more information.

**NOTE:** When enabling this parameter, you must set the forms length to match the physical distance between perforations.

## Shuttle Timeout

The SHUTTLE TIMEOUT parameter determines the amount of time the shuttle will continue running after printing stops. This allows the shuttle to continue moving during the time between print jobs when the print jobs arrive at frequent intervals. Time is saved if the shuttle is still moving when a print job arrives at the printer, since the printer does not have to wait for the shuttle to reach its operating speed.

## Energy Saver Timer

This parameter helps to reduce power consumption when the printer is not in use in order to reduce air pollution caused by power generation. Use of this feature can cut energy use by more than 50 percent.

ENERGY SAVER TIMER determines the amount of time that expires before the printer reduces power after printing stops. The minimum setting is 15 minutes. The amount of time can be selected in one minute increments up to a maximum of 60 minutes. The default time is 15 minutes.

## OCR Font Density

OCR FONT DENSITY determines the print quality for OCR A and OCR B character sets. The following options are available:

- **120** (the default). Vertical is 144; horizontal is 120.
- **180**. Vertical is 144; horizontal is 180.

**NOTE:** The higher the resolution selected, the slower the print speed. When selecting a resolution, try to balance the resolution quality your application requires with how fast you want the print job to print.

## Eject/Restore

The EJECT/RESTORE parameter controls how the printer behaves when the user presses the **Eject/Restore** key. The following options are available:

- STANDARD (the default)
- TOP EXIT TEAR (pedestal models only)

When STANDARD mode is selected, the **Eject/Restore** key operates as follows:

- Pressing **Eject/Restore** causes the paper to advance a preset distance of 22 inches.
- Pressing **Ready** or pressing **Eject/Restore** a second time causes the paper to return to its original position.

**NOTE:** If you are using this function to tear off forms, you might want to press **Form Feed** before using the **Eject/Restore** function. This will avoid unloading the paper as it is restored to its original position.

When TOP EXIT TEAR mode is selected, the **Eject/Restore** key operates as follows:

- Pressing **Eject/Restore** causes the paper to advance the bottom of the last printed form to the tear position, ready for the operator to tear off the printed forms.



- Pressing **Eject/Restore** a second time causes the paper to move into position such that the top of the first possible form available for printing is positioned ready for printing. (The direction and amount of paper movement will depend on the length of the forms; one or more blank forms will be skipped.)

**NOTE:** The TOP EXIT TEAR setting is meaningful only on pedestal model printers. TOP EXIT TEAR cannot be selected on cabinet model printers.

Forms length must be set correctly for the TOP EXIT TEAR mode to function properly.

# Configuration Management Menu

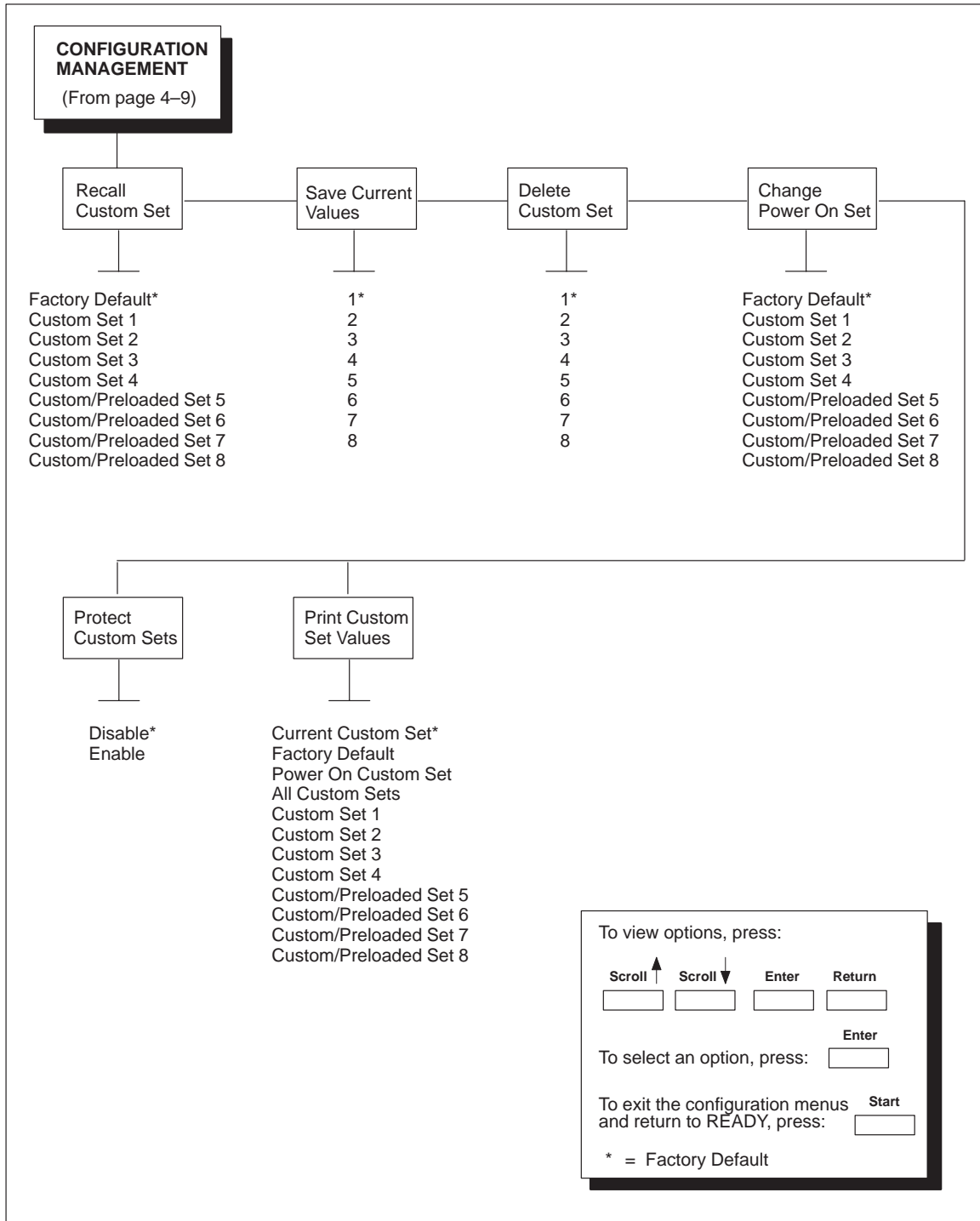

Figure 4–3. Configuration Management Menu

## Recall Custom Set

The printer can store 8 custom sets in NVRAM. This parameter allows you to select and load a specific custom set.

Factory Default is the factory-preset custom set; its parameters cannot be changed. It is always available for loading.

Custom/Preloaded Sets 5–8 contain configuration sets that assist with the installation and configuration of this printer. These sets are preloaded at the factory. If these sets are not used, you can delete them and create new custom sets. For example, Custom/Preloaded Set 8 is preconfigured for the Coax/Twinax Multi-Platform Feature; but if you do not intend to use this feature, you can delete Custom/Preloaded Set 8 or overwrite it with a new set of configuration values. Following is a brief description of Custom/Preloaded Sets 5–8:

- Custom/Preloaded Set 5 is used when configuring this printer to function like a Printronix printer. This custom set contains ASCII emulations used by Printronix compatible printers along with initial defaults (Overstrike, Auto LF, etc.). The initial ASCII default emulation is P-Series which may need to be altered for P-Series XQ or Serial Matrix in some applications. For more information, refer to the Configuration Utility Diskette shipped with this printer, or the *6400 ASCII Programmer's Reference Manual*.
- Custom/Preloaded Set 6 contains the default settings for an ASCII printer using a set of Epson and Proprinter default values. This could be useful when the printer has the Coax/Twinax feature, but is sometimes run as an ASCII printer. Refer to the *6400 Coax/Twinax Programmer's Reference Manual* for more information.
- Custom/Preloaded Set 7 contains default settings for a Twinax printer without IPDS. This could be useful when the printer contains the IPDS feature, but most occasionally be used as a non-IPDS printer. Refer to the *6400 IPDS Programmer's Reference Manual* or the *6400 Coax/Twinax Programmer's Reference Manual* for more information.
- Custom/Preloaded Set 8 contains a custom set for use with the optional Coax/Twinax Multi-Platform Interface feature. Refer to the *Coax/Twinax Multi-Platform Feature Installation and Operation Guide* for more information on this custom set.

## Save Current Values

This option allows you to save your custom sets to meet different print job requirements. This eliminates the need to change the parameter settings for each new job.

The custom sets are stored in NVRAM—they will not be lost if you power off the printer.

Factory default is a factory-preset custom set; it cannot be changed or saved.

### IMPORTANT

**A new custom set will *overwrite* an existing custom set if the PROTECT CUSTOM SETS parameter is disabled (e.g., a new Custom Set 4 will overwrite an existing Custom Set 4). See the “Protect Custom Sets” in this section.**

## Delete Custom Set

You can delete one or all of your customized or preloaded custom sets. Factory default is a factory-preset custom set and cannot be changed or deleted.

## Change Power On Set

You can specify which of the custom sets will be the power-on custom set. The printer will power on with the factory set values or with one of the customized configurations.

## Protect Custom Sets

The PROTECT CUSTOM SETS option specifies whether or not a new custom set can overwrite an existing custom set when you activate the SAVE CURRENT VALUES parameter.

- DISABLE (the default) turns protection off, allowing you to overwrite existing custom sets.
- ENABLE turns protection on, preventing you from overwriting existing custom sets. If you attempt to save to an existing set, the following operator panel message appears:

```
042 CUSTOM SET ALREADY EXISTS  
DELETE EXISTING SET FIRST
```

You must delete the existing set before trying to save the new custom set.

## Print Custom Set Values

This option is used to print a listing of various stored printer custom sets. It is recommended that you store the printout of the custom sets in a safe place for quick referral.

# Twinax Interface Menu

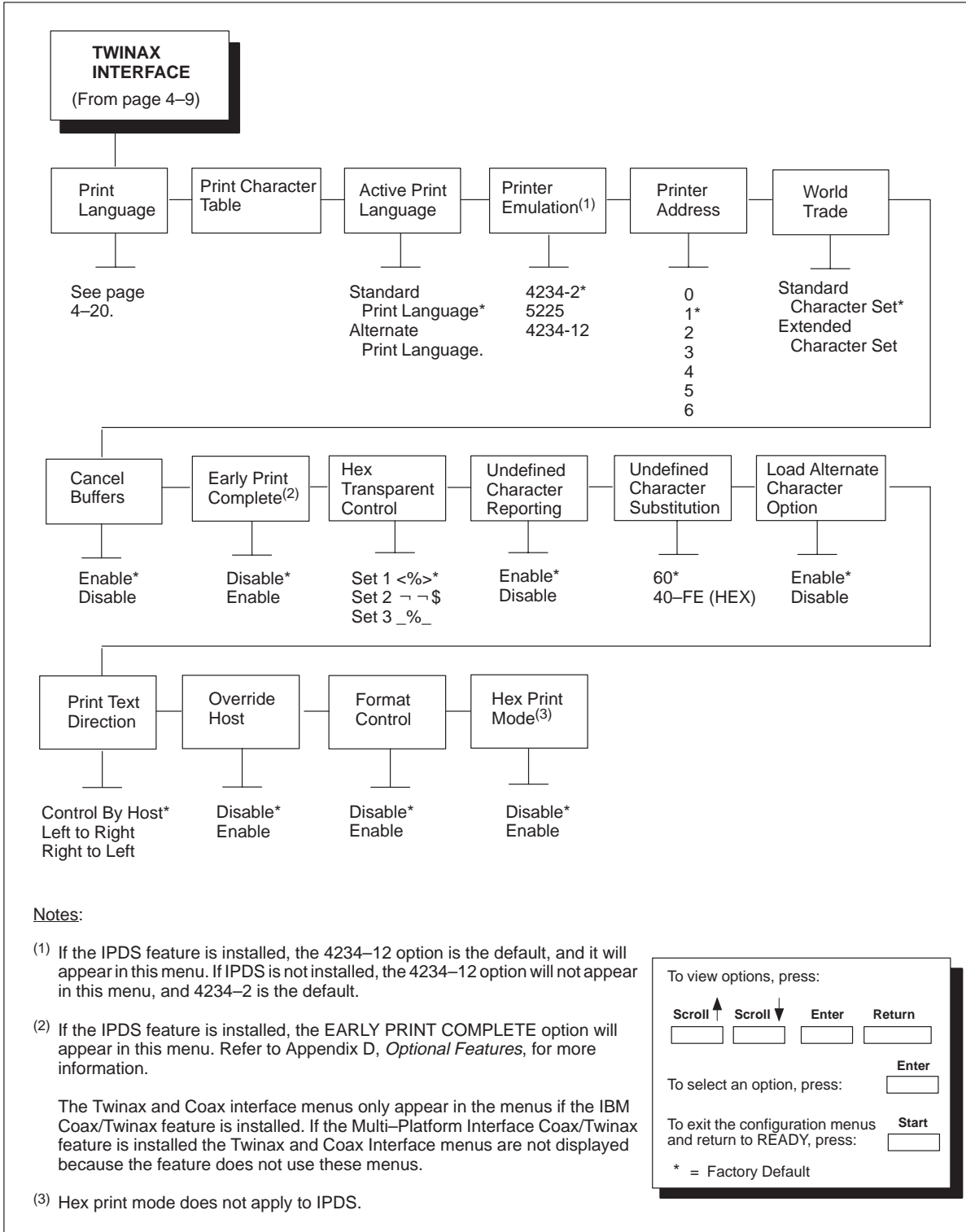
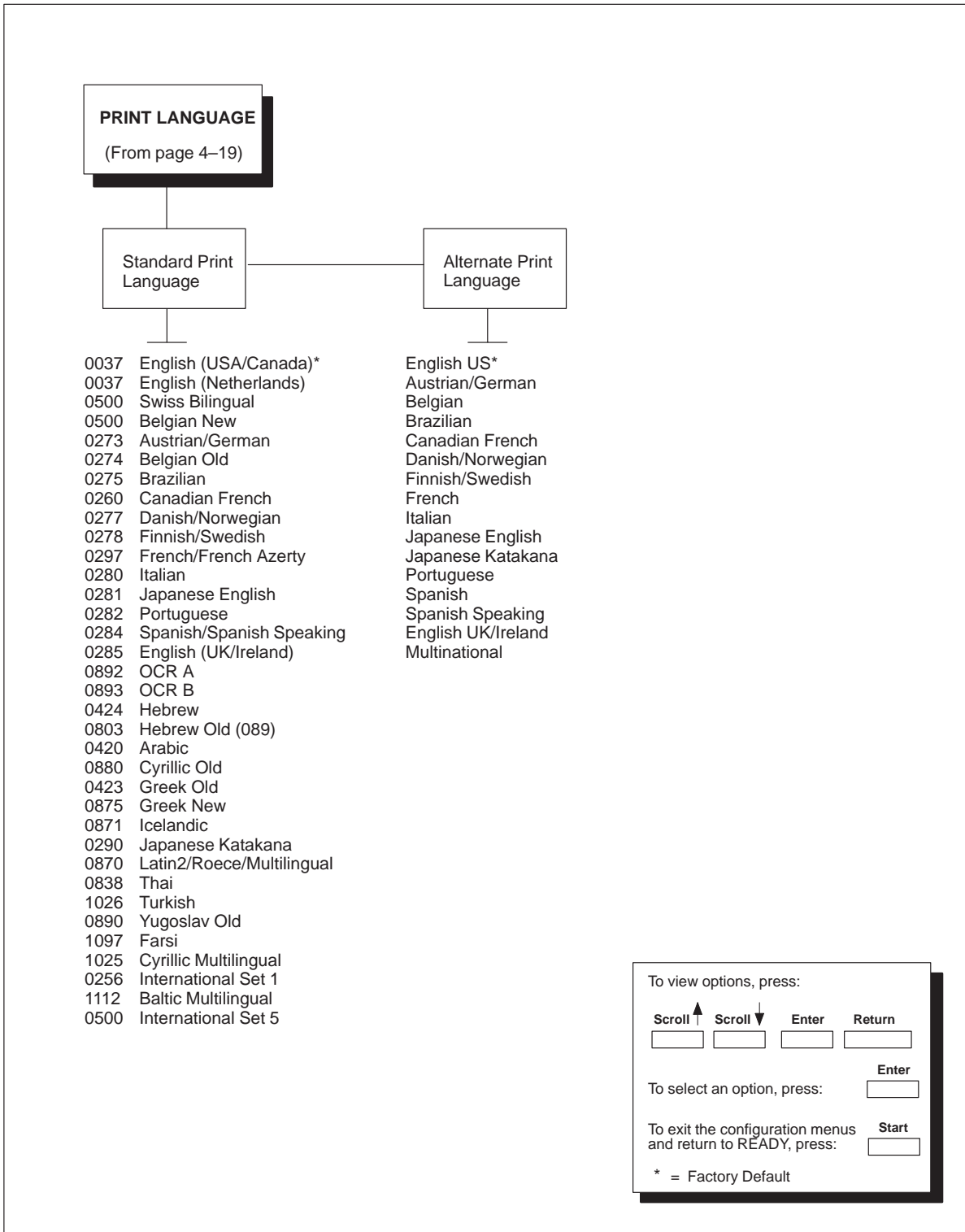

Figure 4-4. Twinax Interface Menu



**Figure 4-5. Twinax Print Language Menu**

## Print Language

PRINT LANGUAGE specifies the set of print languages used by the printer. Refer to Figure 4–5 for print language menus.

- STANDARD PRINT LANGUAGE (the default)
- ALTERNATE PRINT LANGUAGE provides code pages compatible with 6408/6412 Model CT0 printers. Use this option with the 5225 printer emulation.

Specifying a print *quality* of OCR A or OCR B will change the print *language* to OCR A or OCR B.

When OCR A or OCR B is selected as the default print language, OCR A and OCR B are the only available values for this print quality. If a different print quality value is desired, the print language must be changed first.

## Print Character Table

PRINT CHARACTER TABLE prints out a table of the twinax interface's current character set.

Character sets are shown in the *6400 Coax/Twinax Programmer's Reference Manual*.

## Active Print Language

ACTIVE PRINT LANGUAGE specifies which print language set will be the active set.

- STANDARD PRINT LANGUAGE (the default)
- ALTERNATE PRINT LANGUAGE

## Printer Emulation

This parameter defines the printer emulation, as follows:

- 5225
- 4234–2 (the default)
- 4234–12

The 4234–12 selection is only present if the IPDS feature is installed. The 4234–12 selection is also the default if the IPDS feature is installed, otherwise, the 4234–2 is the default.

After the emulation has been changed, a POR status is sent to the host.

## Printer Address

PRINTER ADDRESS allows you to set the device address from 0 through 6. The host directs data and commands on the twinax line to a specific device based on its unique device address.

After the address has been changed, a POR status is sent to the host.

## World Trade (5225 Only)

The 5225 emulation has a multinational character set that serves as a base for 14 world trade character set assortments. They are shown in the *6400 Coax/Twinax Programmer's Reference Manual*.

You can configure the printer as STANDARD CHARACTER SET so the printer contains the IBM World Trade character set, such as the Austria/Germany character set. Or, you can select EXTENDED CHARACTER SET and use the multinational character set as a base with the selected world trade character set overlaid. Ensure that you select ALTERNATIVE PRINT LANGUAGE.

## Cancel Buffers

CANCEL BUFFERS has the following options:

- ENABLE (the default) cancels all buffers when a job is put on hold from the host or the **Cancel** key is pressed.
- DISABLE clears the twinax internal buffer, not the print engine buffers, when a job is put on hold from the host or the **Cancel** key is pressed.

## Early Print Complete

Early Print Complete allows the printer to send Print Complete status to the host before the printer is actually printing all data. Early Print Complete is only available if the IPDS feature is installed.

- DISABLE (the default) means the printer will suppress the Early Print Complete response until all printing is complete.
- ENABLE means the printer will send an acknowledgement to the host when it is able to accept more data.

**NOTE:** When an Early Print Complete is enabled and an error occurs, the data in the printer will remain in the buffer (regardless of the setting of the Cancel Buffer option). It is recommended that local procedures be followed to recover from the error.



## Hex Transparent Control

You can enable additional features that are not available in standard IBM emulations. To access these features, send text commands in the data stream. The commands must have a start and end code. Set 1 is the factory default. Three sets (each containing a start and end code) are available:

- Set 1: start code = <%  
end code = >
- Set 2: start code = - -  
end code = \$
- Set 3: start code = \_%  
end code = \_

## Undefined Character Reporting

UNDEFINED CHARACTER REPORTING allows overriding of the host setting of the SGEA (Set Graphic Error Action) command. For more information about the SGEA command, refer to the *6400 Coax/Twinax Programmer's Reference Manual*.

- ENABLE (the default) is the host setting for the SGEA and is used by the printer. If the SGEA command is requested to stop on graphic errors, the printer will stop when a graphic error is detected.
- DISABLE ignores the SGEA command from the host. The printer does not stop when an error is detected; instead, it substitutes the character selected in the “UNDEFINED CHARACTER SUBSTITUTION” menu entry.

## Undefined Character Substitution

UNDEFINED CHARACTER SUBSTITUTION specifies the replacement character to print in place of any unprintable character that is received from the host. The character becomes the printer default when:

- The printer is powered off and then powered on.
- An SGEA command specifies to use the operator panel default.
- The “UNDEFINED CHARACTER REPORTING” option is disabled.

The character code point can range from hex 40 to hex FE. The factory default is set to hex 60.

## Load Alternate Character Option

The LOAD ALTERNATE CHARACTER (LAC) OPTION allows the host system to load alternate character images into the printer. This may be used for designing graphics, bar codes, and charts, or for printing in foreign languages.

- ENABLE (the default) prints the LAC character as defined.
- DISABLE ignores the LAC definition from the host and prints from the currently selected character set.

## Print Text Direction

PRINT TEXT DIRECTION specifies the direction in which characters are printed on the page. This allows the printer to print languages that are printed right to left instead of left to right.

- CONTROL BY HOST (the default)
- LEFT TO RIGHT
- RIGHT TO LEFT

## Override Host

OVERRIDE HOST determines whether the printer ignores certain commands sent by the host, or continues to use the current printer settings. The following host commands are ignored when OVERRIDE HOST is enabled: line length, forms length, lines per inch (LPI), characters per inch (CPI), print quality, and text orientation (i.e. left to right). When OVERRIDE HOST is enabled, these settings retain their operator panel settings.

**NOTE:** Host margin and tab settings will be used whether or not OVERRIDE HOST is enabled.

- DISABLE (the default) allows certain host commands (line length, forms length, LPI, CPI, print quality, and text orientation) to override operator panel settings. Note that the information appearing on the message display may *not* match the data stream setting. No values will change upon initial selection of the disable option.
- ENABLE permits operator panel settings to override host data stream commands.

## Format Control

FORMAT CONTROL enables the printer to reflect the same spacing as 6408/6412 Model CT0 printers after absolute and relative move commands are executed. The following options are available:

- DISABLE (the default) reflects distance, generated by the Code V feature, IGP feature, and Hex Transparent control code sequence, in the new position (after absolute and relative move commands are executed).
- ENABLE does not reflect distance, generated by the Code V feature, IGP feature, and Hex Transparent control code sequence, in the new position (after absolute and relative move commands are executed).

## Hex Print Mode

When enabled, the HEX PRINT MODE parameter prints the EBCDIC data and control codes received from the host as hex values. Refer to page 6–10 to obtain a hex code printout.

**NOTE:** Printing in Hex Mode may alter print attributes set by the host computer. A power cycle may be required after changing HEX PRINT MODE from enable to disable.

# Coax Interface Menu

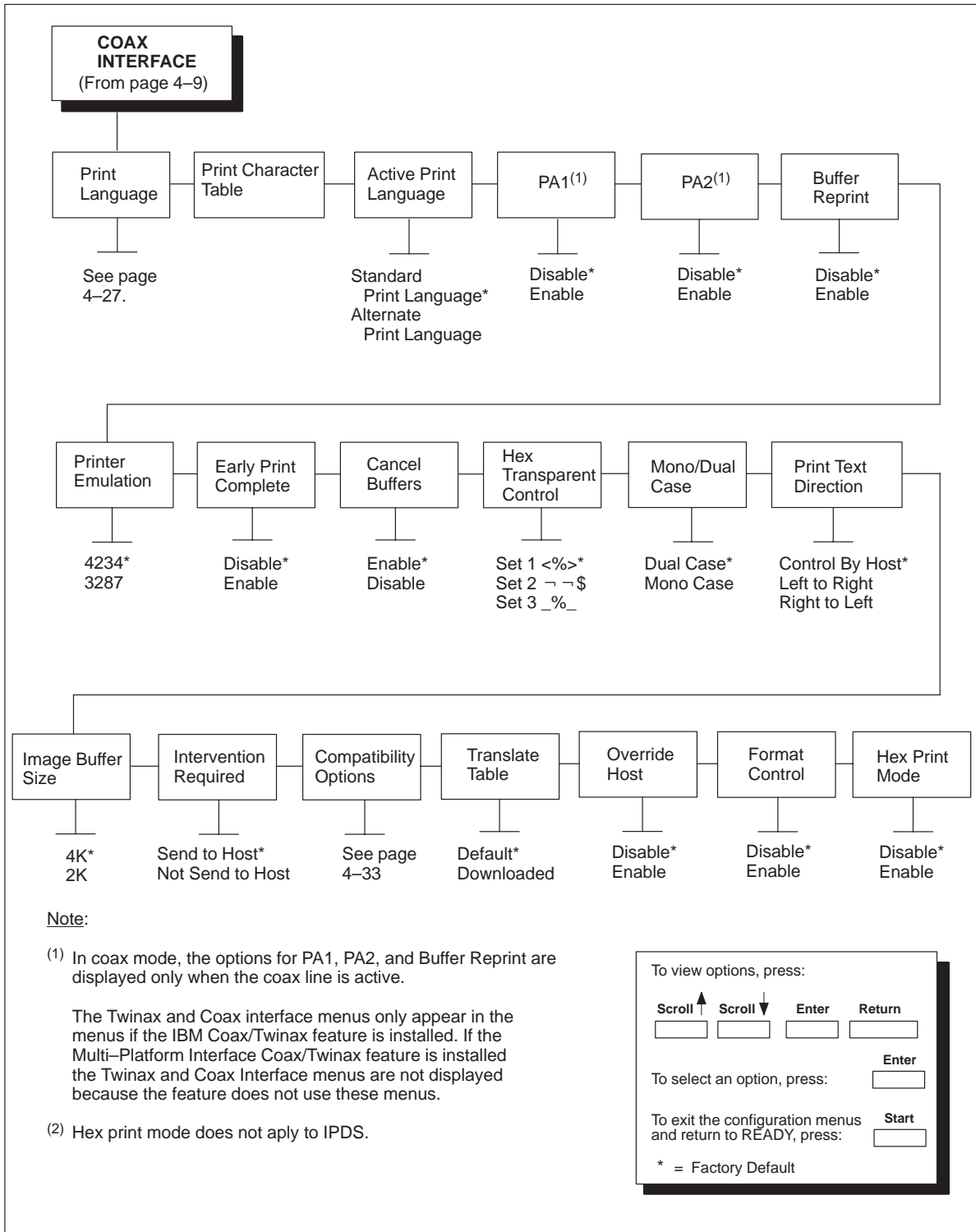
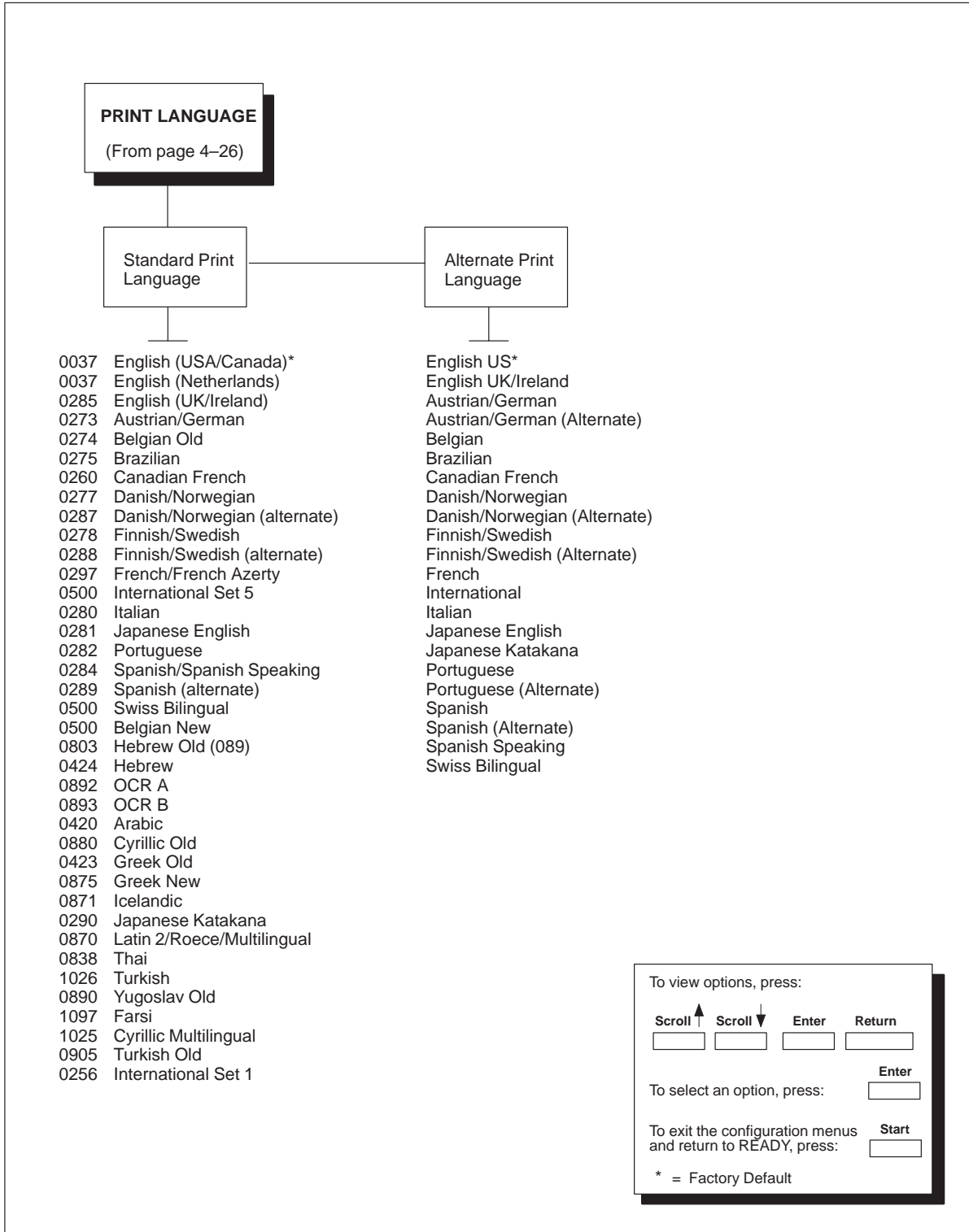

Figure 4-6. Coax Interface Menu



**Figure 4-7. Coax Print Language Menu**

## Print Language

PRINT LANGUAGE specifies the set of print languages used by the printer. Refer to Figure 4–7 for print language menus.

- STANDARD PRINT LANGUAGE (the default)
- ALTERNATE PRINT LANGUAGE provides code pages compatible with 6480/6412 Model CT0 printers. Use this option with the 3287 printer emulation.

Specifying a print *quality* of OCR A or OCR B will change the print *language* to OCR A or OCR B.

When OCR A or OCR B is selected as the default print language, OCR A and OCR B are the only available values for this parameter. If a different print quality value is desired, the print language must be changed first.

## Print Character Table

PRINT CHARACTER TABLE prints out a table of the coax interface's current character set.

All coax character sets are shown in the *6400 Coax/Twinax Programmer's Reference Manual*.

## Active Print Language

ACTIVE PRINT LANGUAGE specifies which print language set will be the active set.

- STANDARD PRINT LANGUAGE (the default)
- ALTERNATE PRINT LANGUAGE

## PA1

PA1 is only valid when the printer is in the NOT READY state and the coax System Network Architecture Character Set (SCS) data stream is active. This function displays the "PA1 ENABLED" message when the **Enter** key is pressed and sends a special operator request to the host when the printer is made READY.

Refer to the *6400 Coax/Twinax Programmer's Reference Manual* for more information about SCS.

**NOTE:** Selecting the PA1 menu item again ("PA1 DISABLED" appears on the operator panel) or selecting the PA2 menu item will reset the pending PA1 function.

## PA2

PA2 is only valid when the printer is in the NOT READY state and the coax SCS data stream is active. This function displays the “PA2 ENABLED” message when the **Enter** key is pressed and sends a special operator request to the host when the printer is made READY.

**NOTE:** Selecting the PA2 menu item again (“PA2 DISABLED” appears on the operator panel) or selecting the PA1 menu item will reset the pending PA2 function.

## Buffer Reprint

This option is only valid when the printer is in the NOT READY state and the Coax SCS data stream is active. The printer displays the “ENABLED” message when the **Enter** key is pressed, and sends an Intervention Required Status to the host when the printer goes to READY state.

**NOTE:** Selecting the Buffer Reprint menu item again (“DISABLED” appears on the operator panel) will reset the Buffer Reprint function.

## Printer Emulation

This parameter defines the printer emulation, as follows:

- 4234 (the default)
- 3287

After the emulation has been changed, a POR status is sent to the host.

## Early Print Complete

Early Print Complete capability allows the printer to send Print Complete status to the host before the printer is actually done printing all data.

- DISABLE (the default) means the printer will suppress the Early Print Complete response until all printing is complete.
- ENABLE means the printer will send an acknowledgement to the host when it is able to accept more data.

**NOTE:** When an Early Print Complete is enabled and an error occurs, the data in the printer will remain in the buffer (regardless of the setting of the Cancel Buffer option). It is recommended that local procedures be followed to recover from the error.

## Cancel Buffers

CANCEL BUFFERS has the following options:

- ENABLE (the default) cancels all buffers when a job is put on hold from the host or when the **Cancel** key is pressed.
- DISABLE clears the coax internal buffer, not the print engine buffers, when a job is put on hold from the host or when the **Cancel** key is pressed.

## Hex Transparent Control

You can enable additional printer features that are not available in standard IBM emulations. To access these features, send text commands in the data stream. The commands must have a start and end code. Set 1 is the factory default. Three sets (each containing a start and end code) are available:

- Set 1: start code = <%  
end code = >
- Set 2: start code = - -  
end code = \$
- Set 3: start code = \_%  
end code = -

## Mono/Dual Case

MONO/DUAL CASE specifies the font as MONO Case or DUAL Case (the default). It is available only in non-SCS mode. The host will be notified of the change when the printer is made READY. If the character set is one of the following 'right to left' sets, MONO CASE prints the same as DUAL CASE: Katakana, Hebrew, Hebrew Old, and Farsi.

SCS (System Network Architecture Character String) Mode is controlled by the host computer. Refer to the *6400 Coax/Twinax Programmer's Reference Manual* for more information about non-SCS mode.



## Print Text Direction

PRINT TEXT DIRECTION specifies the direction in which characters are printed on the page. This allows the printer to print languages which are printed right to left instead of left to right.

- CONTROL BY HOST (the default)
- LEFT TO RIGHT
- RIGHT TO LEFT

The “CONTROL BY HOST” option allows printers configured as a 4234 to use the “SET TEXT ORIENTATION” command from the host.

When a RIGHT TO LEFT language is selected, the host will be notified of print direction changes when the printer is made READY.

## Image Buffer Size

IMAGE BUFFER SIZE (screen buffer size) allows you to select the following image buffer sizes:

- 4K (the default)
- 2K

A POR status is sent to the host when the printer is made READY.

## Intervention Required

Select from SEND TO HOST (the default) or NOT SEND TO HOST.

If SEND TO HOST is selected, the printer sends a signal to the host computer when any of the following occur:

- Printer faults occur.
- Hold mode time-out occurs.

If not selected, the printer will only send the signal on printer faults that cause data loss (paper jam, ribbon stall, online platen open, etc.).

## Translate Table

This parameter defines which translate table to use for printing. The following options are available:

- DEFAULT (the default) translates data by using the default table of the current character set.
- DOWNLOADED translates data from EBCDIC to internal code by using the downloaded translate table.

## Override Host

OVERRIDE HOST determines whether the printer ignores certain commands sent by the host, or continues to use the current settings. The following host commands are ignored when OVERRIDE HOST is enabled: line length, forms length, lines per inch (LPI), characters per inch (CPI), print quality, and text orientation (i.e. left to right). When OVERRIDE HOST is enabled, these settings retain their operator panel settings.

- **DISABLE** (the default) allows certain host commands (line length, forms length, LPI, CPI, print quality, and text orientation) to override operator panel settings. Note that the information appearing on the message display may *not* match the data stream setting. No values will change upon initial selection of the disable option.
- **ENABLE** permits operator panel settings to override host data stream commands.

## Format Control

FORMAT CONTROL enables the printer to reflect the same spacing as 6408/6412 Model CT0 printers after absolute and relative move commands are executed. The following options are available:

- **DISABLE** (the default) reflects distance, generated by the Code V feature, IGP feature, and Hex Transparent control code sequence, in the new position (after absolute and relative move commands are executed).
- **ENABLE** does not reflect distance, generated by the Code V feature, IGP feature, and Hex Transparent control code sequence, in the new position (after absolute and relative move commands are executed).

## Hex Print Mode

When enabled, the HEX PRINT MODE parameter prints the EBCDIC data and control codes received from the host as hex values. Refer to page 6–10 to obtain a hex code printout. Disable is the default condition.

**NOTE:** Printing in Hex Mode may alter print attributes set by the host computer. A power cycle may be required after changing HEX PRINT MODE from enable to disable.

## Compatibility Options Menu (Coax Only)

The Compatibility Options menu allows you to select special printer functions in the non-SCS mode, based on the capabilities of the printer emulated.

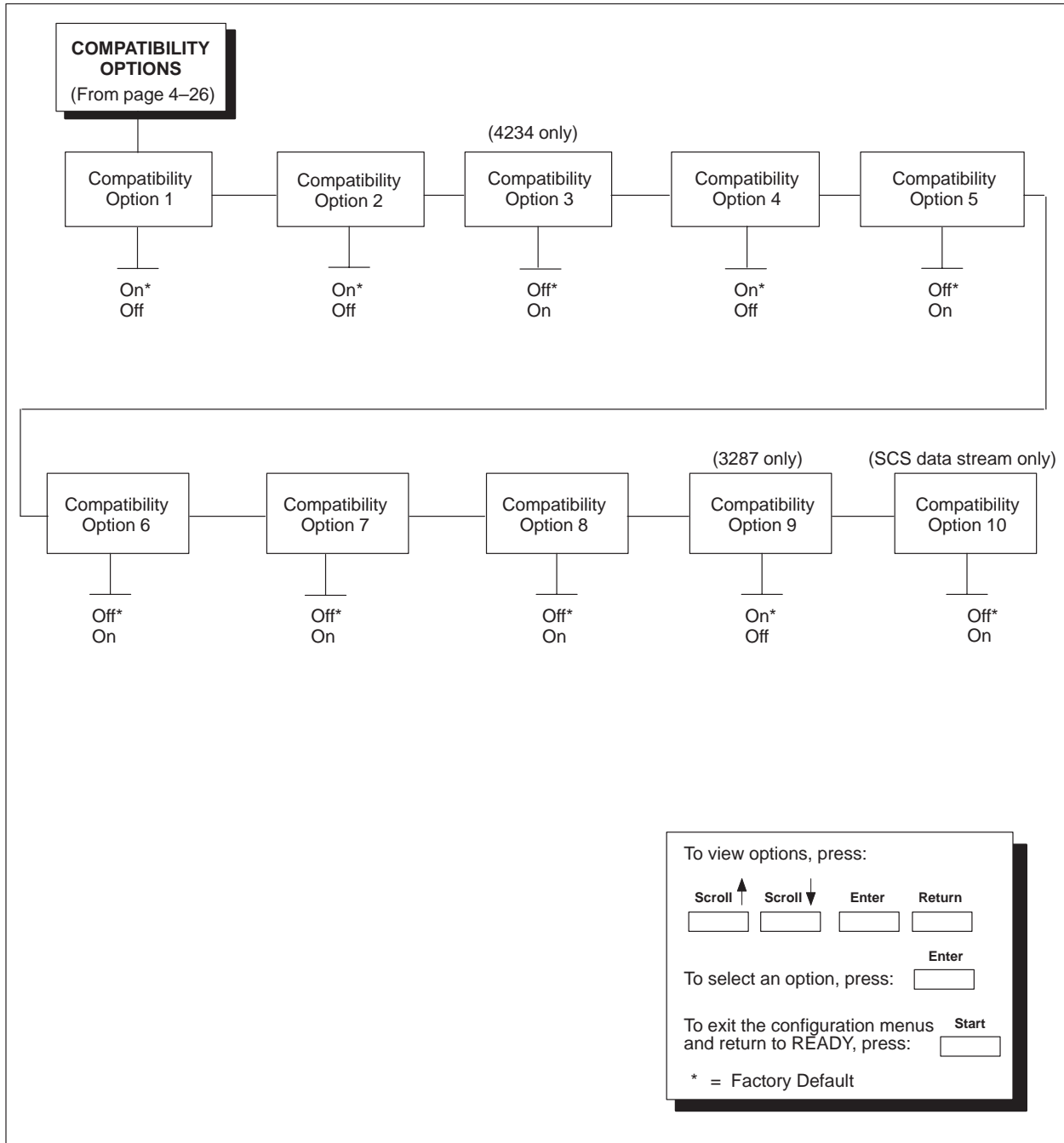

Figure 4–8. Compatibility Options Menu

### **Compatibility Option 1: Carriage Return at MPP+1**

MPP is Maximum Print Position, which is also known as line length.

OPTION 1 controls a carriage return at the end of a print line and at MPP+1.

- ON (the default) produces a carriage return to the first print position of the next line.
- OFF produces a carriage return to the first print position of the current line.

### **Compatibility Option 2: New Line at MPP+1**

NEW LINE AT MPP+1 controls how many lines are skipped when the carriage returns to a new line.

- ON (the default) moves to the first print position of the next print line.
- OFF moves to the first print position two lines down from the current position.

### **Compatibility Option 3: Position After Form Feed (4234 only)**

POSITION AFTER FORM FEED allows you to select the location of the print position after a form feed command is sent.

- OFF (the default) sets the printer to print at position 2 of the first print line on the next form.
- ON sets the printer to print at print position 1 of the first print line on the next form.

### **Compatibility Option 4: Form Feed at End of Print Buffer**

FORM FEED AT END OF PRINT BUFFER determines the print line position when a form feed command is the last code encountered in the print buffer.

- ON (the default) moves to the first print position on the second line of the next form.
- OFF moves to the first print position on the first line of the next form.

**NOTE:** This option is ignored if Compatibility Option 7 is on.

If configured as a 3287, and a form feed occurs in the middle of a print buffer, the printer defaults to the first print position on the second line of the next form, regardless of the setting of this option.

## **Compatibility Option 5: Null Suppression**

NULL SUPPRESSION will either treat nulls as blank spaces or ignore them. If nulls are ignored, the print position does not move.

- OFF (the default) ignores nulls.
- ON treats nulls as blank spaces.

## **Compatibility Option 6: Form Feed Command Position**

FORM FEED COMMAND POSITION determines if the position of a form feed command affects its execution.

- OFF (the default) normally performs a form feed only if it occurs at the first print position in a line or at Maximum Print Position +1. (The Maximum Print Position is the line length.) A form feed command at any other position is recognized as a blank.
- ON allows the printer to perform a form feed command anywhere in the data stream.

## **Compatibility Option 7: Automatic Form Feed at End of Print Buffer**

AUTOMATIC FORM FEED AT END OF PRINT BUFFER specifies whether or not to perform an automatic form feed at the end of a print buffer.

- OFF (the default) performs an automatic new line command after completing a print buffer (unless a form feed, new line, or carriage return command was the last one executed). The printer is set to print at print position 1 of the next line.
- ON performs an automatic form feed after completing a print buffer (unless a form feed command was the last one in the buffer). The printer is set to print at print position 1 of the first line of the next form.

### **Compatibility Option 8: Automatic FF After Operator-Initiated Copy**

This option determines the print position after an operator-initiated local copy (print screen function).

- OFF (the default) performs an automatic new line command after completing a print buffer (unless a new line, form feed or carriage return command was the last one executed). The printer is set to print at print position 1 of the next line.
- ON performs an automatic form feed command unless a form feed was the last one executed. The printer is set to print at print position 1 of the first line on the next form.

### **Compatibility Option 9: CR, EM, and NL (3287 only)**

CR (Carriage Return), EM (Error Message), and NL (New Line) specify that the printer treat the CR, EM, and NL control codes either as spaces or as control codes.

- ON (the default) treats the CR, EM and NL commands as control codes.
- OFF treats the CR, EM and NL commands as spaces.

### **Compatibility Option 10: Bottom Margin (SCS data stream only)**

Any bottom margin specified or implied by a host command will be overridden, causing the operator panel bottom margin value to be used

- Disable (the default) ignores the operator panel bottom margin value.
- Enable forces the bottom margin to the value specified by the operator panel.

## Parallel Interface Menu

More information about these interfaces is in Chapter 5, “Printer Interfaces.”

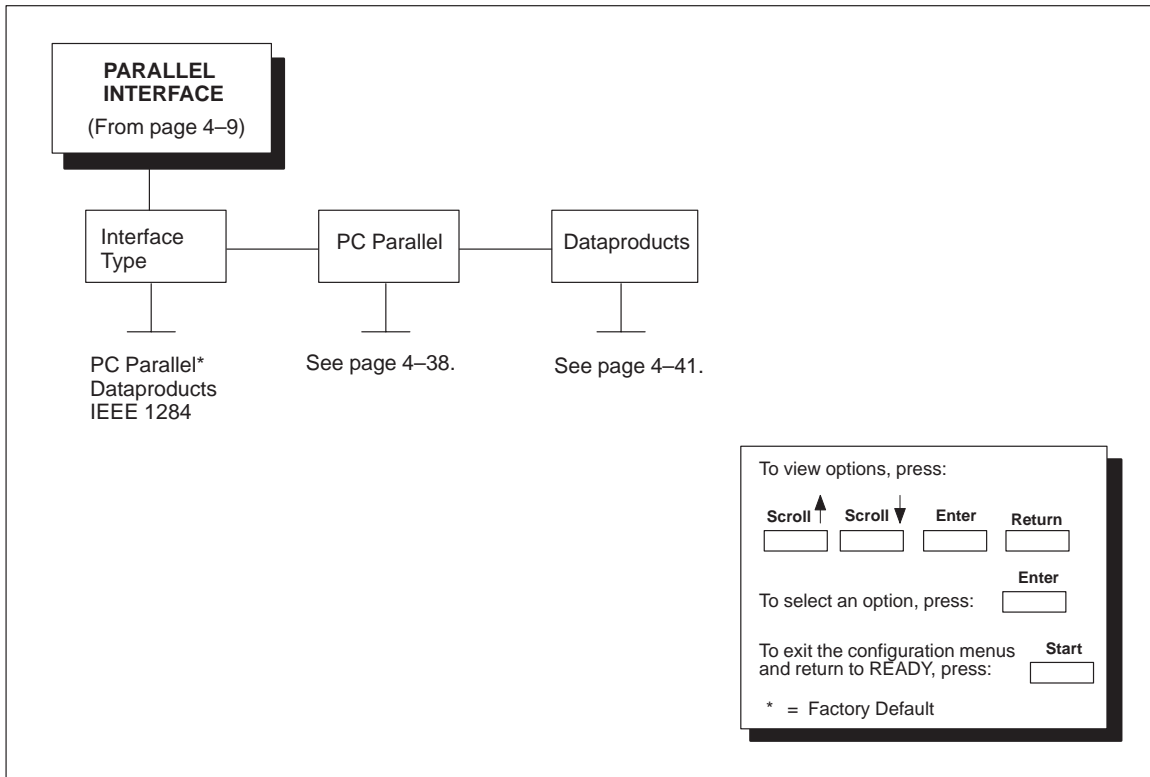

Figure 4–9. Parallel Interface Menu

### Interface Type

The INTERFACE TYPE parameter selects which electrical interface will drive the parallel port interface, as follows:

- PC PARALLEL (the default)
- DATAPRODUCTS
- IEEE 1284

## PC Parallel Menu

The PC PARALLEL menu configures the electrical signals to operate as a PC Parallel printer.

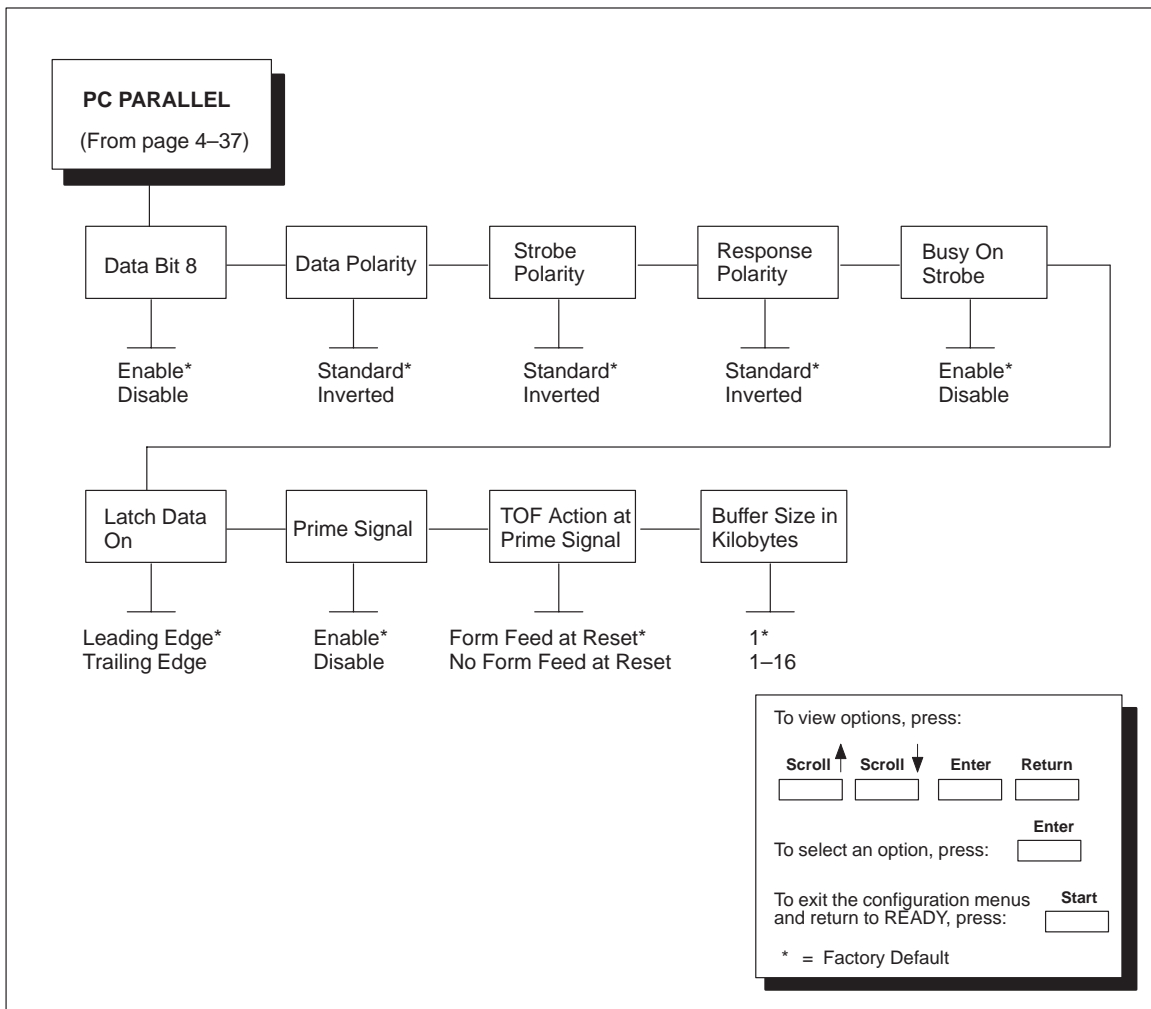

Figure 4-10. PC Parallel Menu



## Data Bit 8

The DATA BIT 8 parameter allows access to the extended ASCII character set. This parameter is enabled by default. When this parameter is disabled, the printer interprets bit 8 of each incoming data character as a zero, regardless of its actual setting.

The extended ASCII character set is shown in the *6400 ASCII Programmer's Reference Manual*.

## Data Polarity

The DATA POLARITY parameter must be set to match the data polarity of your host computer.

- STANDARD (the default) expects the host computer to not invert the data.
- INVERTED expects the host computer to invert the data received on the data lines. Ones become zeros, and vice-versa.

## Strobe Polarity

The STROBE POLARITY must be set to match the data strobe polarity of your host computer. When the host computer sends a data strobe signal to the printer, this enables the printer to read the data bus.

- STANDARD (the default) does not expect the data strobe signal to be inverted.
- INVERTED expects the host computer to invert the data strobe signal.

## Response Polarity

The RESPONSE POLARITY parameter must be set to match the response polarity of your host computer.

- STANDARD (the default) does not invert the response signal.
- INVERTED inverts the response signal sent to the host computer.

## Busy on Strobe

BUSY ON STROBE determines when the Busy signal is asserted.

- ENABLE (the default) asserts a busy signal after each character is received.
- DISABLE asserts a busy signal only when the print buffers are full.

## Latch Data On

The LATCH DATA ON parameter specifies whether the data is read on the leading or trailing edge of the data strobe signal.

- LEADING EDGE (the default)
- TRAILING EDGE

## Prime Signal

- ENABLE (the default). When set and the host asserts the PRIME SIGNAL, the parallel port will perform a warm start.
- DISABLE. The parallel port will not perform a warm start when the host asserts the PRIME SIGNAL.

## TOF Action at Prime Signal

TOF (Top-of-Form) ACTION AT PRIME SIGNAL determines whether or not a form feed is performed before a warm start when the prime signal is asserted from the host. This setting is only used if PRIME SIGNAL parameter is enabled.

- FORM FEED AT RESET (the default)
- NO FORM FEED AT RESET

## Buffer Size in Kilobytes

This parameter determines the size of the input buffer, in 1K increments. Up to 16K are available. 1K is the default.

## Dataproducts Menu

---

The Dataproducts parallel interface is configured using the following configuration options.

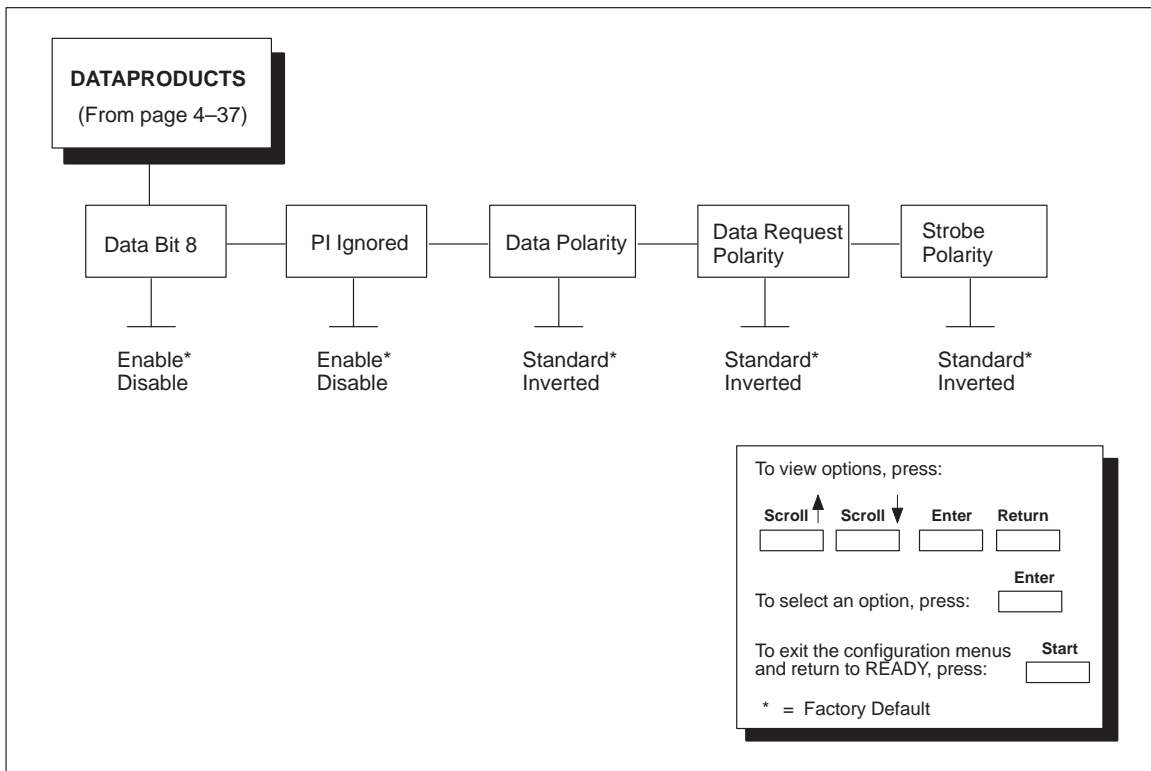

Figure 4–11. Dataproducts Menu

## Data Bit 8

The DATA BIT 8 parameter allows access to the extended ASCII character set. This parameter is enabled by default. When this parameter is disabled, the printer interprets bit 8 of each incoming data character as a zero, regardless of its actual setting.

## PI Ignored

The PI (Paper Instruction) signal is used to control vertical paper motion. When the PI IGNORED parameter is ENABLED (the default) it determines how the printer interprets the PI signal.

## Data Polarity

The DATA POLARITY parameter must be set to match the data polarity of your host computer.

- STANDARD (the default) does not invert the data.
- INVERTED inverts the data received on the data lines from the host computer. Ones become zeros, and vice-versa.

## Data Request Polarity

The DATA REQUEST POLARITY parameter must be set to match the data request polarity of your host computer.

- STANDARD (the default) does not invert the request signal.
- INVERTED inverts the request signal sent to the host computer.

## Strobe Polarity

The STROBE POLARITY must be set to match the data strobe polarity of your host computer. When the host computer sends a data strobe signal to the printer, this enables the printer to read the data bus.

- STANDARD (the default) does not expect the data strobe signal to be inverted.
- INVERTED expects the host computer to invert the data strobe signal.

## IEEE 1284

---

The IEEE 1284 interface has no parameters that are adjustable via the operator panel. For more information, see Chapter 5, “Printer Interfaces.”

# Serial Interface Menu

## IMPORTANT

The serial parameters in the printer must be set to match the serial interface in the host computer (at the other end of the printer data cable). Otherwise, the printer may not operate correctly, and data characters from the computer may not print or may appear as “garbled” text.

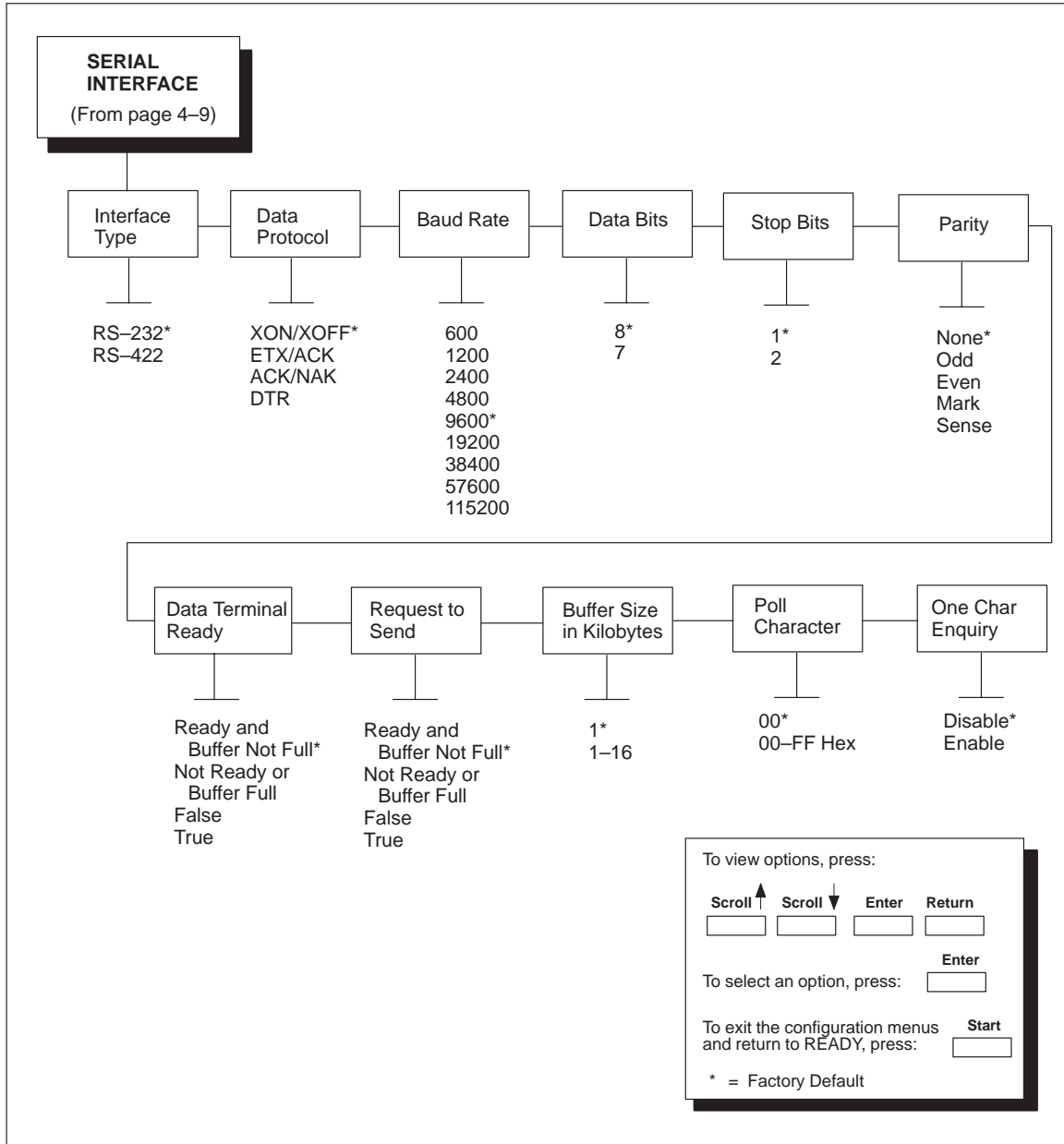

Figure 4-12. Serial Interface Menu

## Interface Type

This parameter configures the electrical interface for the serial port, as follows:

- RS–232 (the default)
- RS–422

## Data Protocol

You may select one of the following serial interface protocols to meet the host interface requirements.

- XON / XOFF (the default) — Transmit On / Transmit Off. The printer controls the flow of communication from the host by telling the host to turn the transmission on and off. This is the factory default serial protocol.
- ETX / ACK — End of Text / Acknowledge. The host controls the flow of communication to the printer by sending a block of data and ending the block with an End of Text (ETX) signal. When the printer receives the ETX signal, it will acknowledge it has received the entire block of data.
- ACK / NAK — Acknowledge / Negative Acknowledge. ACK means acknowledge; the device acknowledges it has accepted a transmission. NAK means a negative acknowledge; the device did not receive the transmission.
- DTR — (DTE Ready). The printer controls the data flow by asserting or de-asserting this hardware signal to the host. If there is enough room in the printer buffer, the printer will send a high signal; if the buffer is full the printer will send a low signal. DTR tells the host if it is safe to send more data. (If the host sends data during an unsafe condition, data will be lost.)

## Baud Rate

This parameter sets the baud rate of the serial interface in the printer. Baud rate is the speed at which serial data is transferred between the host computer and the printer.

- 600 BAUD
- 1200 BAUD

- 2400 BAUD
- 4800 BAUD
- 9600 BAUD (the default)
- 19200 BAUD
- 38400 BAUD
- 57600 BAUD
- 115200 BAUD

### **Data Bits**

The DATA BITS parameter sets the length of the serial data word. The length of the data word must match the corresponding data bits setting in the host computer.

- 8 BITS (the default)
- 7 BITS

### **Stop Bits**

The STOP BITS parameter sets the number of stop bits in the serial data word. The setting must match the corresponding stop bit setting in the host computer. One (1, the default) or two (2) stop bits can be selected.

### **Parity**

The PARITY parameter setting can be set for the following:

- NONE (the default)
- ODD
- EVEN
- MARK
- SENSE

The setting must match the corresponding parity setting in the host computer.

### **Data Terminal Ready**

This configuration is part of hardware flow control and determines when the DATA TERMINAL READY (DTR) signal is generated. This signal indicates whether or not the printer is ready to receive data.

- READY AND BUFFER NOT FULL (the default) asserts the DTR signal when the printer is READY and the internal serial buffer is not full.
- NOT READY OR BUFFER FULL asserts the DTR signal when the printer is NOT READY or the internal serial buffer is full.



- FALSE never asserts the DTR signal.
- TRUE continuously asserts the DTR signal.

## Request to Send

This configuration is part of hardware flow control and determines when the REQUEST TO SEND (RTS) signal is generated. This signal indicates whether or not the printer is ready to receive data.

- READY AND BUFFER NOT FULL (the default) asserts the RTS signal when the printer is READY and the internal serial buffer is not full.
- NOT READY OR BUFFER FULL asserts the RTS signal when the printer is NOT READY or the internal serial buffer is full.
- FALSE never asserts the RTS signal.
- TRUE continuously asserts the RTS signal.

**NOTE:** Xon/Xoff is always on. See page 5–5 for more information.

## Buffer Size in Kilobytes

This parameter determines the size of the input buffer, in 1K increments. Up to 16K are available. 1K is the default.

## Poll Character

This option is used when One Char Enquiry is enabled and the IGP (PGL) feature is available. Whenever the printer receives this character, it sends a response to the host indicating the current state of the printer. It may be configured from 00 to FF Hex. The default value is 00.

## One Char Enquiry

When enabled, and the PGL feature is available, a status byte is sent back to the host when the poll character or the command SFCC enquiry is sent to the printer (serial interface only). The poll character is received and the status byte is sent whether the printer is online or offline. The SFCC enquiry will only be processed when the printer is online.

The status byte sent to the host is defined as follows:

BIT	USE
7,6	0
5	1
4	0
3	1 = printer fault
2	1 = IGP busy
1	0 = offline, 1 = online
0	1 = serial input buffer exceeds xoff/on

# Emulation Configuration Menu

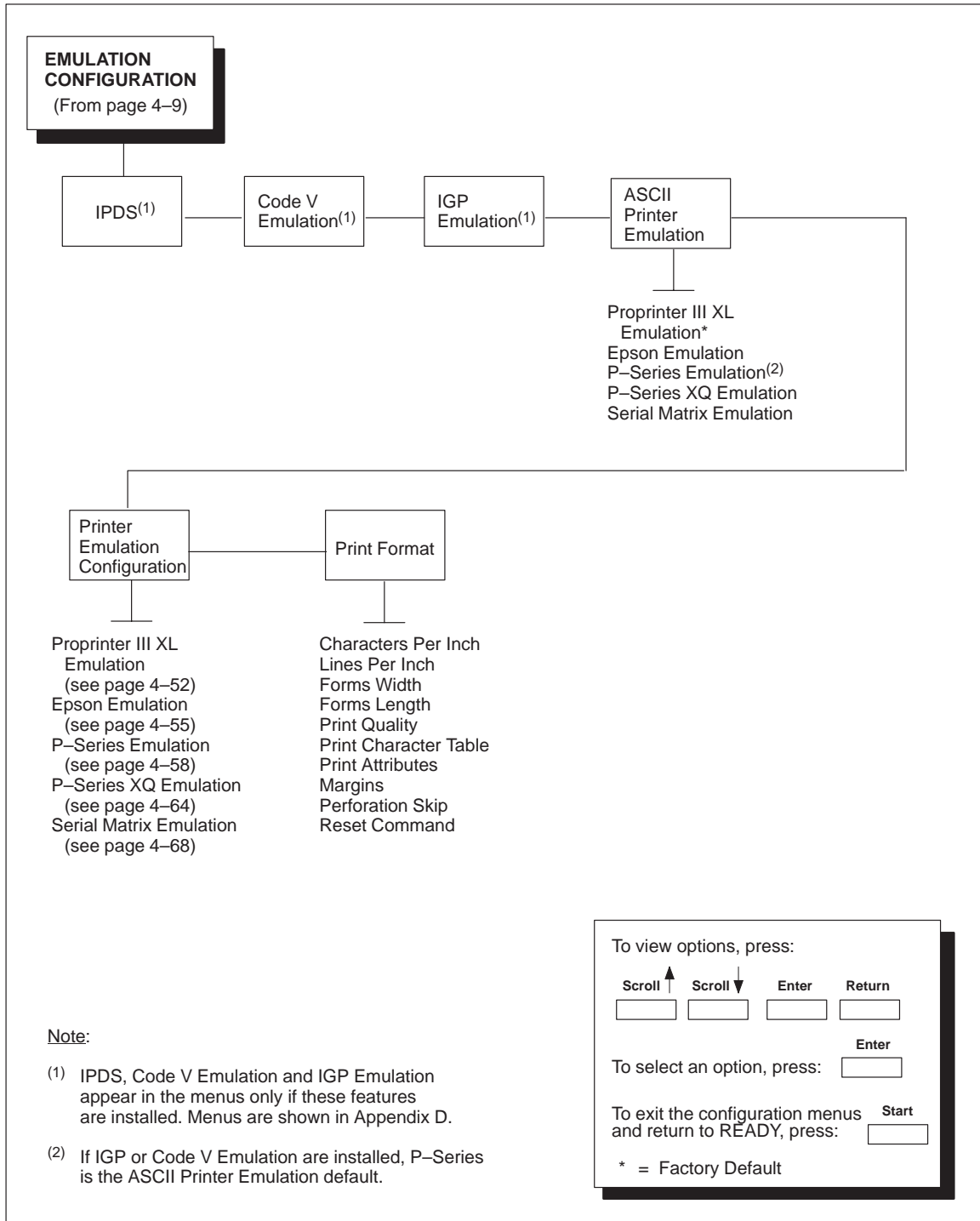

Figure 4-13. Emulation Configuration Menu

Your printer can support many emulations: Proprinter III XL, Epson, P-Series, P-Series XQ, and Serial Matrix. These emulations are included with your printer.

Your printer can support other emulations: IPDS, Code V, and IGP. These emulations are features that must be ordered separately. (These features may have been installed at the factory if the features were ordered with the printer.) For the IPDS emulation, the IBM Coax/Twinax feature must be installed.

All the emulations contain the same configuration submenus shown on page 4–9. The “EMULATION CONFIGURATION” submenu, however, is unique for each emulation; refer to Appendix D for optional emulation feature configuration menus.

For more information on these features, refer to the documentation shipped with the feature or to the “Related Documents” section that begins on page 1–3.

## **ASCII Printer Emulation**

This parameter selects one of the following ASCII printer emulations as the active emulation:

- PROPRINTER III XL EMULATION (the default)
- EPSON EMULATION
- P-SERIES EMULATION
- P-SERIES XQ EMULATION
- SERIAL MATRIX EMULATION

The configuration for the active emulation is selected from the Printer Emulation Configuration menu, described on pages 4–52 through 4–80.

## **Printer Emulation Configuration**

This parameter configures the ASCII printer emulation and page formatting. The submenus (further described on pages 4–52 through 4–80) are as follows:

- PROPRINTER III XL EMULATION
- EPSON EMULATION
- P–SERIES EMULATION
- P–SERIES XQ EMULATION
- SERIAL MATRIX EMULATION

## **Print Format**

This parameter configures page formatting. The submenus are described on pages 4–73 through 4–80.

# Proprinter III XL Emulation Menu

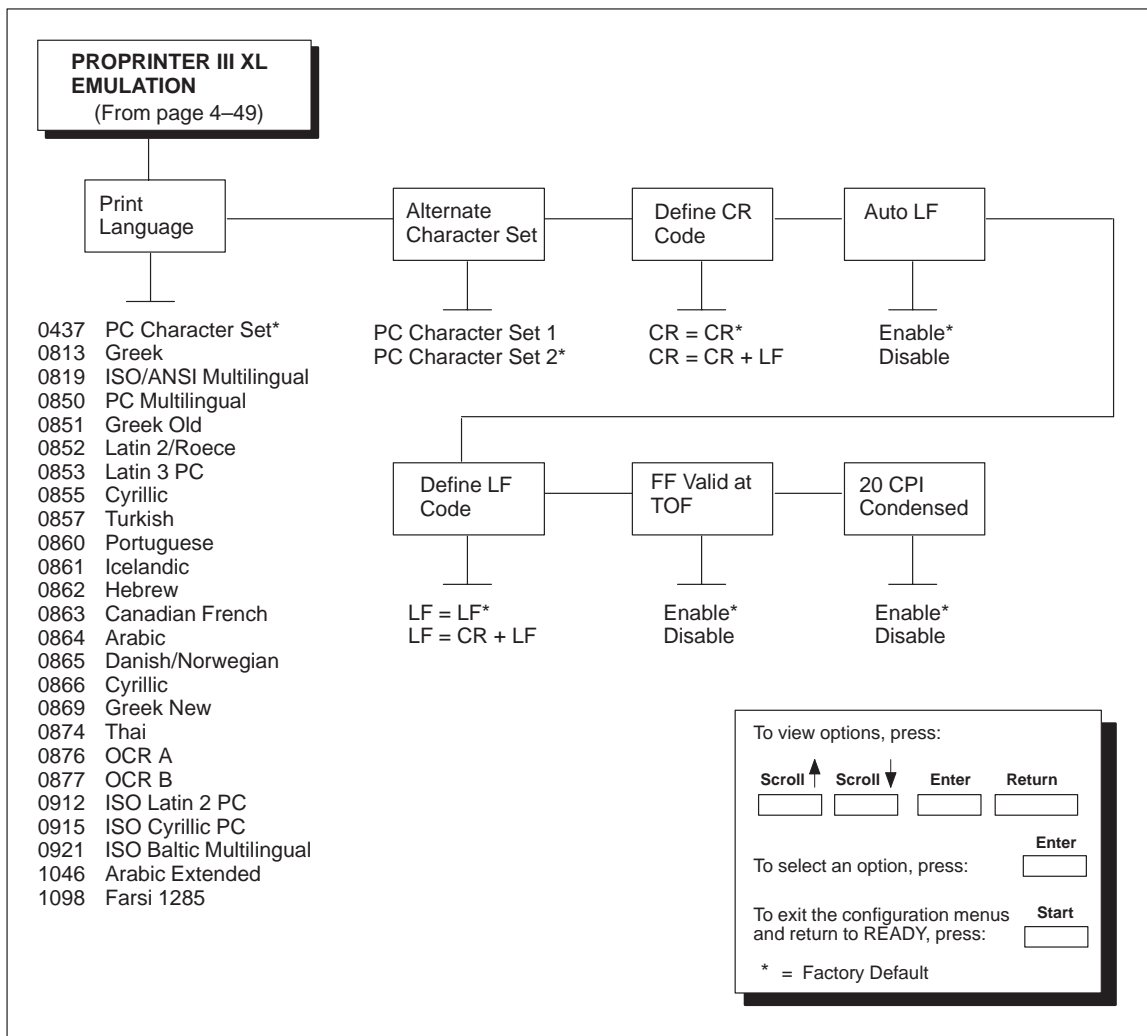

Figure 4-14. Proprinter III XL Emulation Menu

## Print Language

This parameter selects a print language for the Proprinter III XL emulation. Each PRINT LANGUAGE selection supports a different foreign language character set. A host data stream command that changes the print language overrides the print language that is specified via the operator panel. Note that when 0876 OCR A or 0877 OCR B is selected as the print language, the print quality is changed to OCR A or OCR B, respectively. See the *6400 ASCII Programmer's Reference Manual* for more information on character sets.

## Alternate Character Set

This parameter determines if the characters in the hex 80 through hex 9F range are printable characters or control codes.

- PC Character Set 1 = control codes.
- PC Character Set 2 = printable characters (the default).

## Define CR Code

The DEFINE CR CODE (Define Carriage Return Code) option controls the action of the printer when it receives a Carriage Return code (0D hex) from the host computer. If this feature is enabled, each time the printer receives a Carriage Return, it inserts an additional Line Feed code (0A hex) into the data stream. Do not use this feature if the host computer sends Line Feeds to the printer.

- CR = CR is the default.
- CR = CR + LF inserts an extra Line Feed after each Carriage Return.

## Auto LF

The AUTO LF (Auto Line Feed) option defines the printer actions when print data is received past the forms width setting.

- ENABLE (the default) performs an automatic carriage return and line feed when data is received past the forms width.
- DISABLE discards any data past the forms width.

## Define LF Code

The DEFINE LF CODE (Define Line Feed Code) option controls the action of the printer when it receives a Line Feed code (0A hex) from the host computer. If this feature is enabled, each time the printer receives a Line Feed, it inserts an additional Carriage Return code (0D hex) into the data stream. This feature can be used in most installations, but it is required if the host computer does not send Carriage Returns to the printer.

- LF = LF (the default) produces a Line Feed.
- LF = CR + LF adds an extra Carriage Return with each Line Feed.

## FF Valid at TOF

The FF VALID AT TOF (Form Feed Valid at Top of Form) option determines whether the printer will perform a Form Feed when the host sends a Form Feed command, if the printer is at the Top of Form. The printer will perform a Form Feed when the operator panel **Form Feed** key is pressed, regardless of this option setting.

- ENABLE (the default) performs a form feed when the host sends a Form Feed command and the printer is at the top of form.
- DISABLE will not perform a form feed when the host sends a Form Feed command and the printer is at the Top of Form.

## 20 CPI Condensed

When the 20 CPI CONDENSED (20 Characters Per Inch Condensed) option is enabled, and compressed print is chosen by the host computer, the printer prints characters that are about 60 percent of the width of normal characters. For example, a 12 CPI Draft font will compress to 20 CPI. This is helpful for applications where you need to print the maximum amount of information on a page.

- ENABLE (the default) prints narrow characters when compressed print is chosen by the host computer.
- DISABLE will not compress the character widths, even if condensed print is chosen by the host.



# Epson Emulation Menu

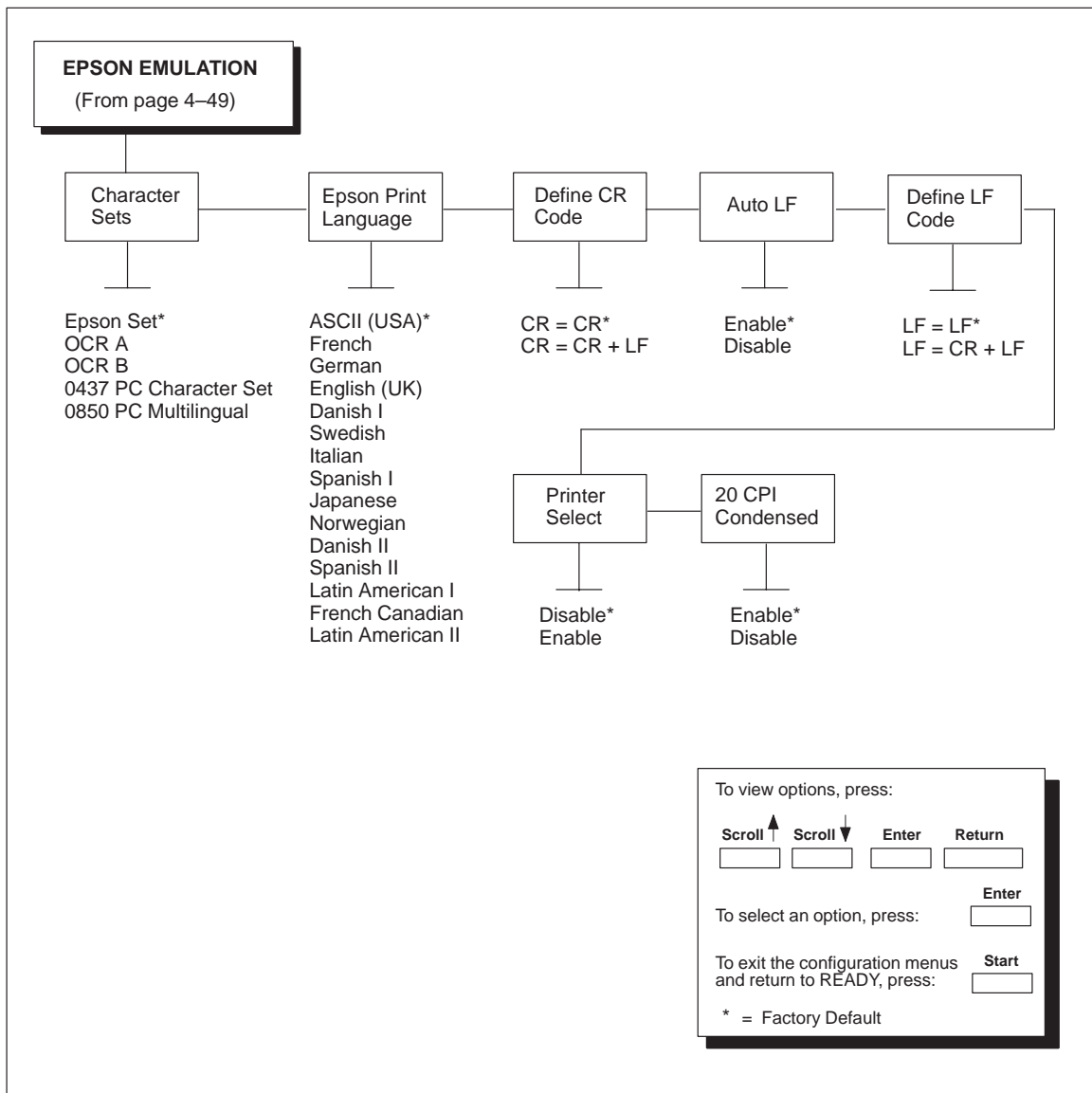

Figure 4-15. Epson Emulation Menu

## Character Sets

This parameter selects a character set for the Epson emulation. Note that when 0876 OCR A or 0877 OCR B is selected as the print language, the print quality is changed to OCR A or OCR B, respectively. See the *6400 ASCII Programmer's Reference Manual* for more information on character sets.

## Epson Print Language

This parameter selects a print language for the Epson emulation. Each print language selection supports a different foreign language character set. A host data stream command that changes the print language overrides the print language that is specified via the operator panel.

## Define CR Code

The DEFINE CR CODE (Define Carriage Return Code) option controls the action of the printer when it receives a Carriage Return code (0D hex) from the host computer. If this feature is enabled, each time the printer receives a Carriage Return, it inserts an additional Line Feed code (0A hex) into the data stream. Do not use this feature if the host computer sends Line Feeds to the printer.

- CR = CR (the default) does not insert an extra Line Feed after each Carriage Return.
- CR = CR + LF inserts an extra Line Feed after each Carriage Return.

## Auto LF

The AUTO LF (Auto Line Feed) option defines the printer actions when print data is received past the forms width setting.

- ENABLE (the default) performs an automatic carriage return and line feed when data is received past the forms width.
- DISABLE discards any data past the forms width.

## Define LF Code

The DEFINE LF CODE (Define Line Feed Code) option controls the action of the printer when it receives a Line Feed code (0A hex) from the host computer. If this feature is enabled, each time the printer receives a Line Feed, it inserts an additional Carriage Return code (0D hex) into the data stream. This feature can be used in most installations, but it is required if the host computer does not send Carriage Returns to the printer.

- LF = LF (the default) does not add a Carriage Return with a Line Feed.
- LF = CR + LF adds an extra Carriage Return with each Line Feed.

## Printer Select

This option determines if the ASCII DC1 and DC3 control codes can be used to disable and enable the printer.

- DISABLE (the default) ignores the DC1 and DC3 control codes.
- ENABLE disables the printer when a DC1 control code is received, and enables the printer when a DC3 control code is received.

## 20 CPI Condensed

When the 20 CPI CONDENSED (20 Characters Per Inch Condensed) option is enabled, and compressed print is chosen by the host computer, the printer prints characters that are about 60 percent of the width of normal characters. For example, a 12 CPI Draft font will compress to 20 CPI. This is helpful for applications where you need to print the maximum amount of information on a page.

- ENABLE (the default) prints narrow characters when compressed print is chosen by the host computer.
- DISABLE will not compress the character widths, even if condensed print is chosen by the host.

# P-Series Emulation Menu

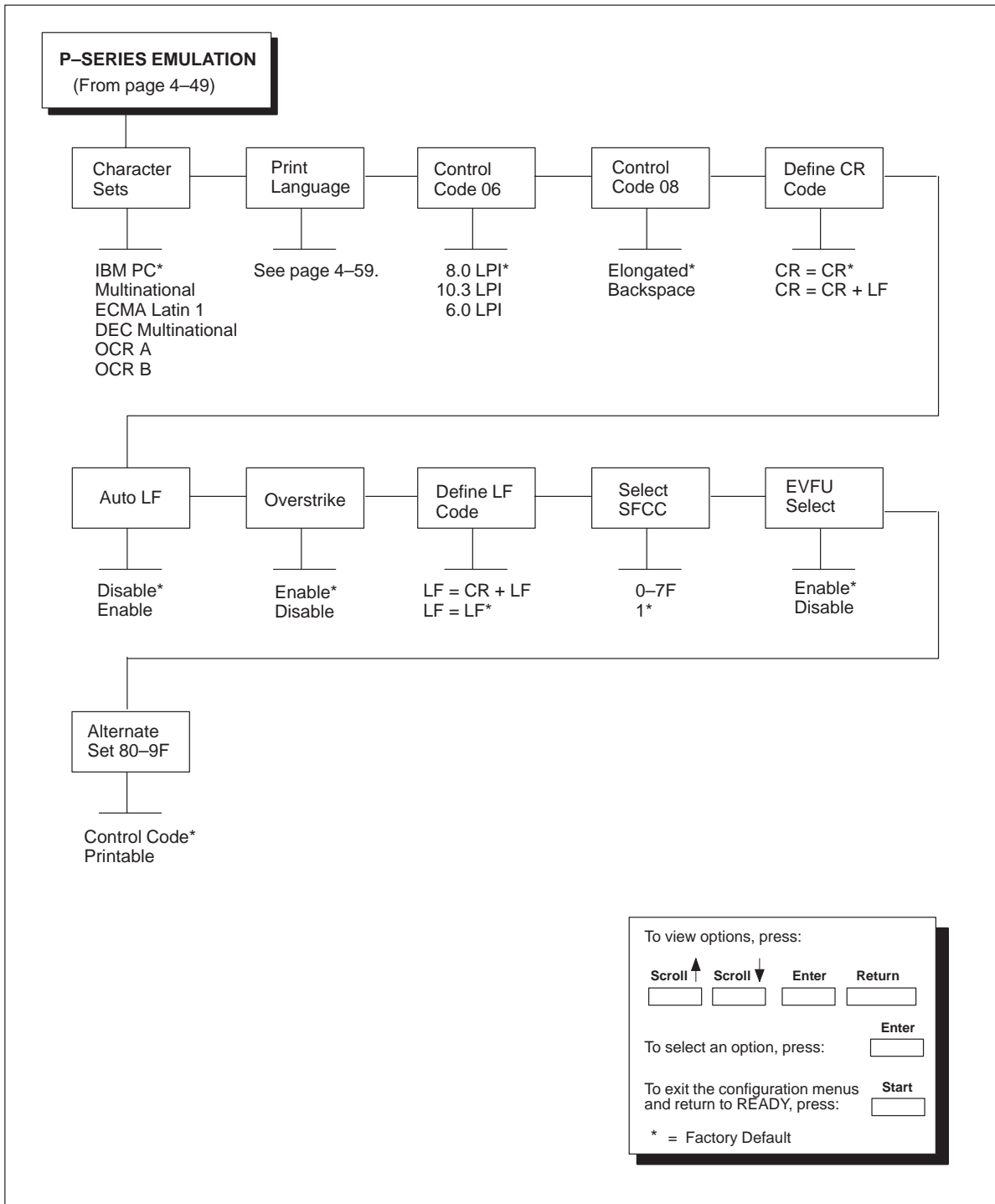
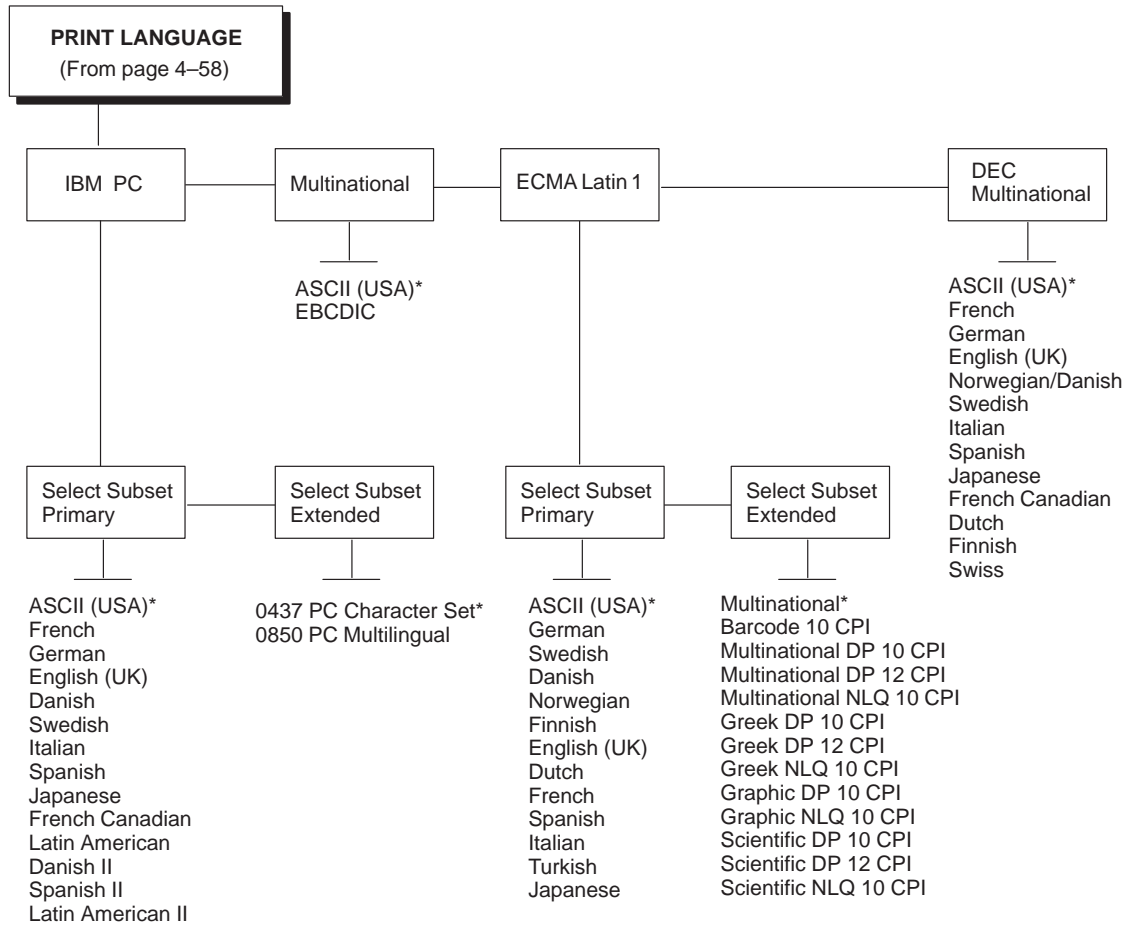

Figure 4-16. P-Series Emulation Menu

(Continued from the P-Series Emulation Menu)



To view options, press:

**Scroll** ↑    **Scroll** ↓      **Enter**     **Return**

To select an option, press:  **Enter**

To exit the configuration menus and return to READY, press:  **Start**

\* = Factory Default

Figure 4-17. P-Series Print Language Menu

## Character Sets

This parameter selects a character set for the P-Series emulation. Once you have selected a character set, you must also define a print language for that character set, described under the PRINT LANGUAGE option.

- IBM PC (the default)
- MULTINATIONAL
- ECMA LATIN 1
- DEC MULTINATIONAL
- OCR A
- OCR B

**NOTE:** See the *6400 ASCII Programmer's Reference Manual* for information on character sets.

## Print Language

If you selected one of the character sets other than OCR A/OCR B (which have only one available print language), you must also select a print language for that character set. The print languages available for each character set are shown in Figure 4-17 on page 4-59. The default print language for each character set follows:

- IBM PC: Default for Select Subset Primary is ASCII (USA).  
Default for Select Subset Extended is 0437 PC Character Set.
- MULTINATIONAL: Default is ASCII (USA).
- ECMA LATIN 1: Default for Select Subset Primary is ASCII (USA).  
Default for Select Subset Extended is MULTINATIONAL.
- DEC MULTINATIONAL: Default is ASCII (USA).

## Control Code 06

This option will select alternate line spacing. When the printer receives a hex 06 command, the line spacing will change to spacing specified in this option for the current line only.

- 8.0 LPI (the default)
- 10.3 LPI
- 6.0 LPI

## Control Code 08

This option determines the action to take when a hex 08 command is received.

- ELONGATED (the default) prints double high characters for the current line.
- BACKSPACE moves the current print position one space to the left unless the printer is currently at print position 1.

## Define CR Code

The DEFINE CR CODE (Define Carriage Return Code) option controls the action of the printer when it receives a Carriage Return code (0D hex) from the host computer. If this feature is enabled, each time the printer receives a Carriage Return, it inserts an additional Line Feed code (0A hex) into the data stream. Do not use this feature if the host computer sends Line Feeds to the printer.

- CR = CR (the default) does not insert an extra Line Feed after each Carriage Return.
- CR = CR + LF inserts an extra Line Feed after each Carriage Return. The next print position will be print position 1 of the next line.

## Auto LF

The AUTO LF (Auto Line Feed) option defines the printer actions when print data is received past the forms width setting.

- DISABLE (the default) discards any data past the forms width.
- ENABLE performs an automatic carriage return and line feed when data is received past the forms width.

## Overstrike

The OVERSTRIKE option determines the action required when a line is printed over a previous line because a carriage return was received without a line feed.

- ENABLE (the default) prints the second line on top of the first line.
- DISABLE replaces the characters from the first line with the second line.

## Define LF Code

The DEFINE LF CODE (Define Line Feed Code) option determines whether an automatic carriage return should occur whenever a line feed command is received.

- LF = CR + LF forces an automatic carriage return with each line feed command. The next print position will be position 1 of the next line.
- LF = LF (the default) does not perform an automatic carriage return. The next print position will be the current print position of the next line.

## Select SFCC

The SELECT SFCC option determines what hex code to use as the Special Function Control Character (SFCC). When a printer control code consists of more than one character, it is called a command sequence. The SFCC alerts the printer that a command sequence is next and not a printable character. The option SFCC can range from 0 through 7F. The factory default value is 1. See the *6400 ASCII Programmer's Reference Manual* for more information.

## EVFU Select

The EVFU SELECT (Electronic Vertical Format Unit Select) option determines if EVFU skips can be defined. An EVFU skip is an instruction to move the paper to a specific location on a form. See the *6400 ASCII Programmer's Reference Manual* for more information.

- ENABLE (the default) defines EVFU skips.
- DISABLE does not define EVFU skips.



## **Alternate Set 80–9F**

This option determines if data in the range of hex 80 through hex 9F should be interpreted as a control code or as a printable character.

- **CONTROL CODE** (the default) interprets data in the range of hex 80 through hex 9F as a control code.
- **PRINTABLE** prints data in the range of hex 80 through hex 9F.

# P-Series XQ Emulation Menu

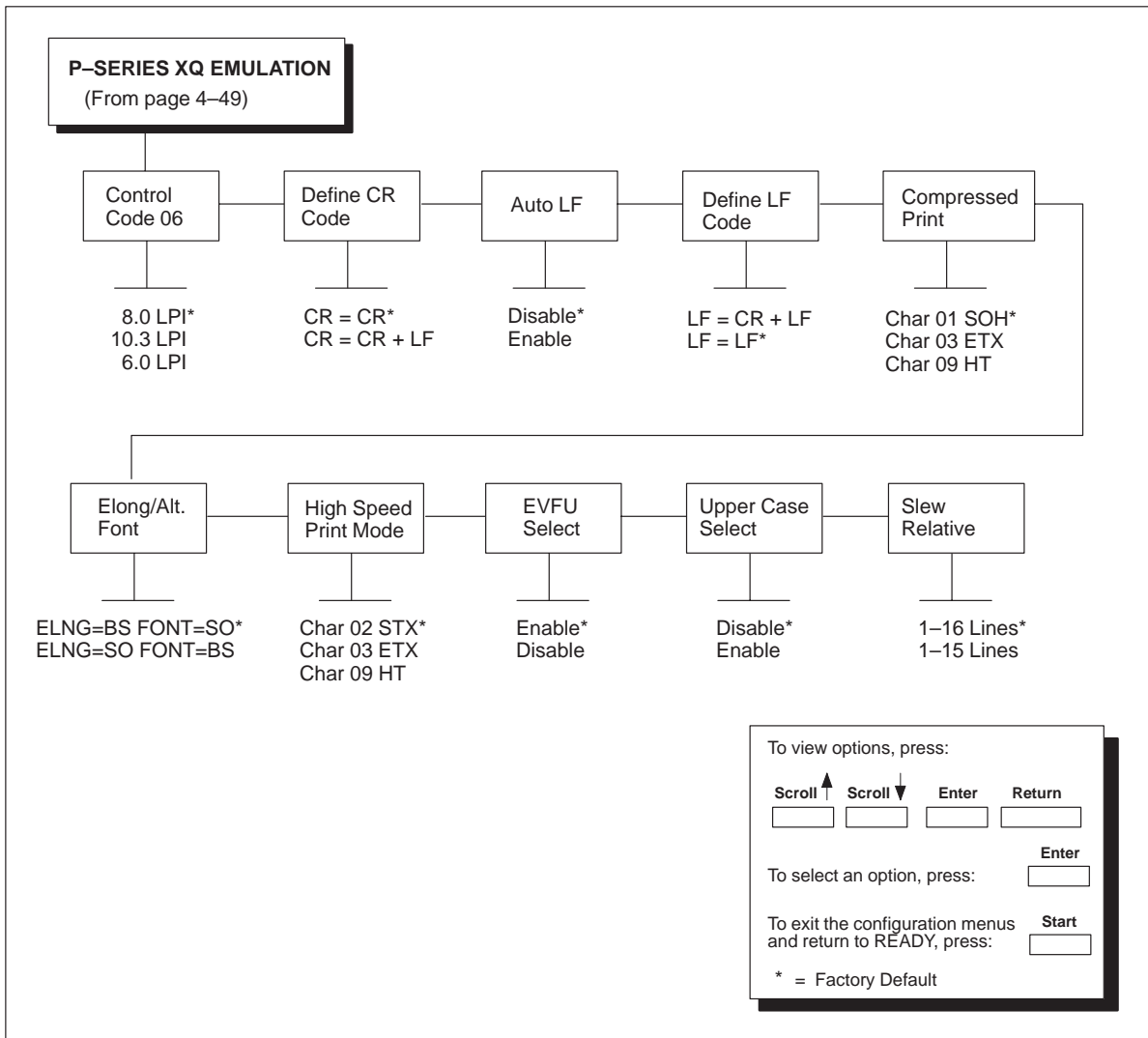

Figure 4-18. P-Series XQ Emulation Menu

## Control Code 06

This option will select alternate line spacing. When the printer receives a hex 06 command, the line spacing will change to spacing specified in this option for the current line only.

- 8.0 LPI (the default)
- 10.3 LPI
- 6.0 LPI

## Define CR Code

The DEFINE CR CODE (Define Carriage Return Code) option controls the action of the printer when it receives a Carriage Return code (0D hex) from the host computer. If this feature is enabled, each time the printer receives a Carriage Return, it inserts an additional Line Feed code (0A hex) into the data stream. Do not use this feature if the host computer sends Line Feeds to the printer.

- CR = CR (the default) does not insert an extra Line Feed after each Carriage Return.
- CR = CR + LF inserts an extra Line Feed after each Carriage Return. The next print position will be print position 1 of the next line.

## Auto LF

The AUTO LF (Auto Line Feed) option defines the printer actions when print data is received past the forms width setting.

- DISABLE (the default) discards any data past the forms width.
- ENABLE performs an automatic carriage return and line feed when data is received past the forms width.

## Define LF Code

The DEFINE LF CODE (Define Line Feed Code) option determines whether an automatic carriage return should occur whenever a line feed command is received.

- LF = CR + LF forces an automatic carriage return with each line feed command. The next print position will be position 1 of the next line.
- LF = LF (the default) does not perform an automatic carriage return. The next print position will be the current print position of the next line.

## Compressed Print

The COMPRESSED PRINT option controls which host command sets compressed printing.

- CHAR 01 SOH (the default)
- CHAR 03 ETX
- CHAR 09 HT

## Elong/Alt. Font

The ELONG/ALT. FONT (Elongated/Alternate Font) option determines which host command selects elongated (double high) fonts and extended character set.

- ELNG=BS (Ø8 hex)      FONT=SO (ØE hex) (the default)
- ELNG=SO                      FONT=BS

## High Speed Print Mode

The HIGH SPEED PRINT MODE option determines which host command selects high speed printing.

- CHAR 02 STX (the default)
- CHAR 03 ETX
- CHAR 09 HT

## EVFU Select

The EVFU SELECT (Electronic Vertical Format Unit Select) option determines if EVFU skips can be defined. An EVFU skip is an instruction to move the paper to a specific location on a form. See the *6400 ASCII Programmer's Reference Manual* for more information.

- ENABLE (the default) defines EVFU skips.
- DISABLE does not define EVFU skips.

## Upper Case Select

The UPPER CASE SELECT option controls how the printer handles lowercase characters it receives from the host computer. When enabled, all characters will be printed in uppercase.

- DISABLE (the default) prints lowercase characters received from the host computer as lowercase, and uppercase characters received from the computer as uppercase.
- ENABLE prints lowercase characters received from the host computer as their corresponding uppercase equivalents; uppercase characters received from the computer are printed as uppercase.

## Slew Relative

The SLEW RELATIVE option determines the number of lines slewed (the number of lines the form is advanced to a preset location) when an EVFU Slew Relative command is received.

For further information, refer to the EVFU information in the *6400 ASCII Programmer's Reference Manual*.

- 1–16 LINES (the default)
- 1–15 LINES

# Serial Matrix Emulation Menu

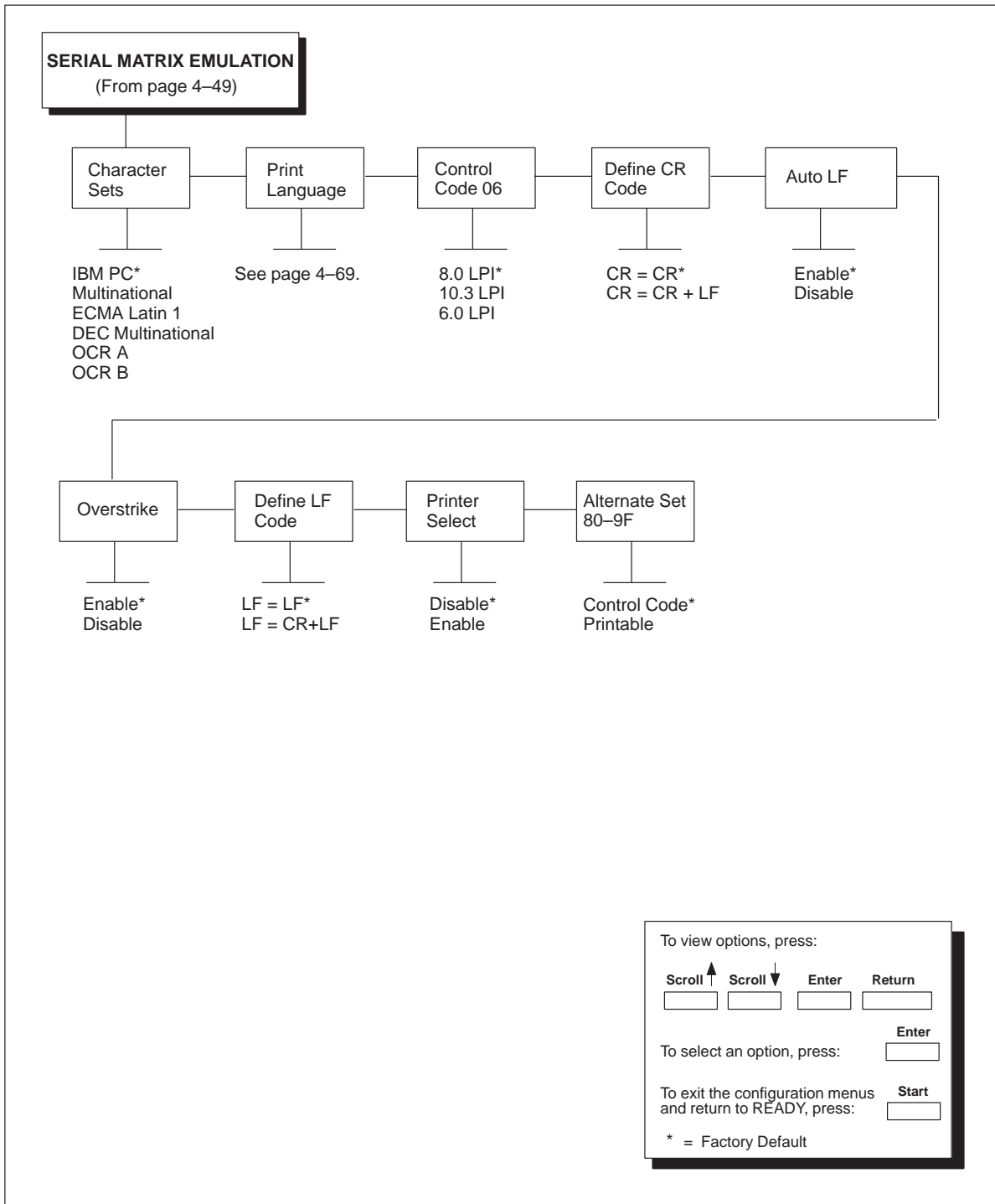

Figure 4-19. Serial Matrix Emulation Menu

(Continued from the Serial Matrix Emulation Menu)

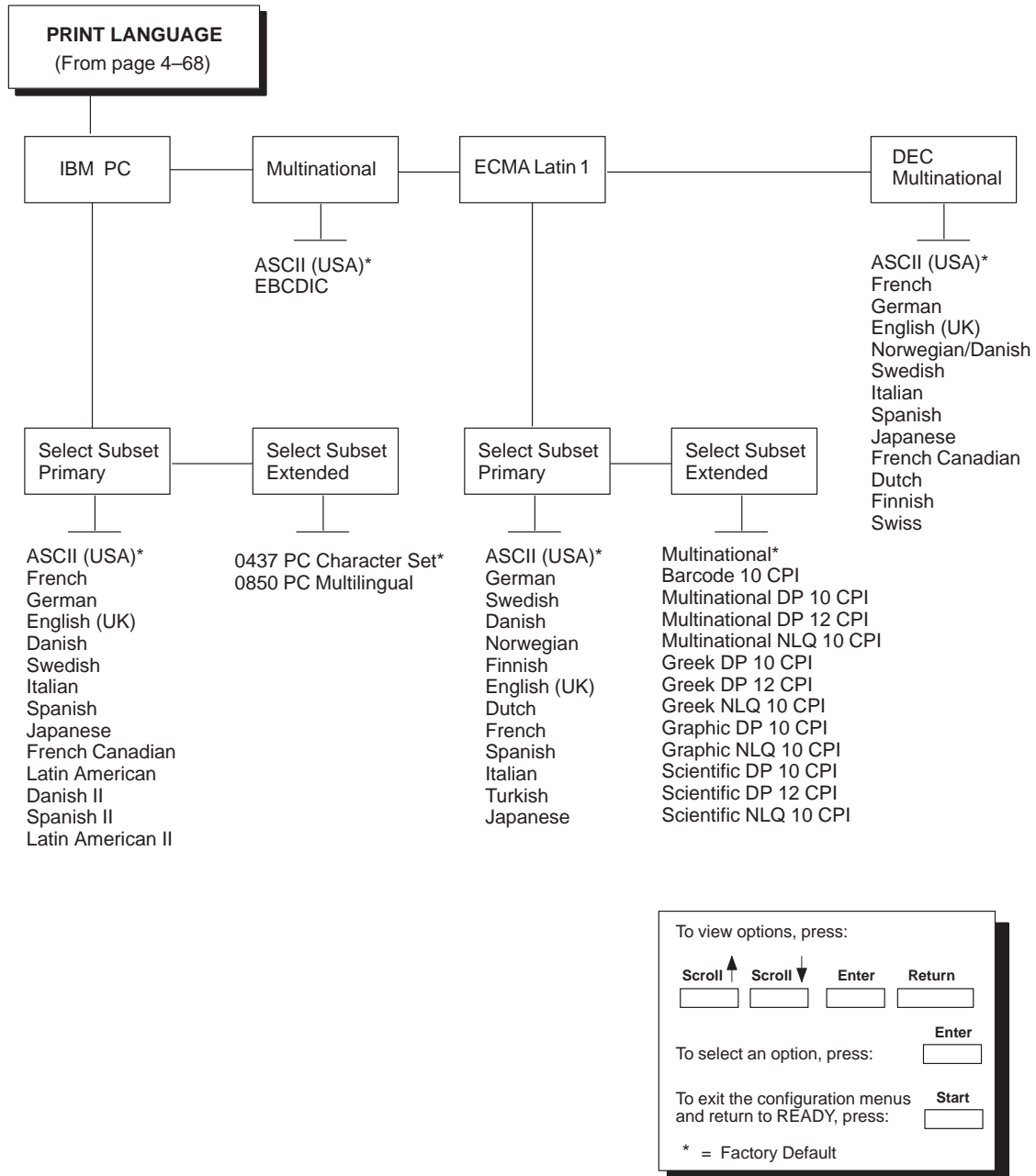

Figure 4-20. Serial Matrix Print Language Menu

## Character Sets

This parameter selects a character set for the Serial Matrix emulation. Once you have selected a character set, you must also define a print language for that character set, described under the PRINT LANGUAGE option.

- IBM PC (the default)
- MULTINATIONAL
- ECMA LATIN 1
- DEC MULTINATIONAL
- OCR A
- OCR B

**NOTE:** See the *6400 ASCII Programmer's Reference Manual* for more information on character sets.

## Print Language

If you selected one of the character sets other than OCR A/OCR B (which have only one available print language), you must also select a print language for that character set. The print languages available for each character set are shown in Figure 4–20. The default print language for each character set follows:

- IBM PC: Default for Select Subset Primary is ASCII (USA).  
Default for Select Subset Extended is 0437 PC Character Set.
- MULTINATIONAL: Default is ASCII (USA).
- ECMA LATIN 1: Default for Select Subset Primary is ASCII (USA).  
Default for Select Subset Extended is MULTINATIONAL.
- DEC MULTINATIONAL: Default is ASCII (USA).



## Control Code 06

This option will select alternate line spacing. When the printer receives a hex 06 command, the line spacing will change to spacing specified in this option for the current line only.

- 8.0 LPI (the default)
- 10.3 LPI
- 6.0 LPI

## Define CR Code

The DEFINE CR CODE (Define Carriage Return Code) option controls the action of the printer when it receives a Carriage Return code (0D hex) from the host computer. If this feature is enabled, each time the printer receives a Carriage Return, it inserts an additional Line Feed code (0A hex) into the data stream. Do not use this feature if the host computer sends Line Feeds to the printer.

- CR = CR (the default) does not insert an extra Line Feed after each Carriage Return.
- CR = CR + LF inserts an extra Line Feed after each Carriage Return. The next print position will be print position 1 of the next line.

## Auto LF

The AUTO LF (Auto Line Feed) option defines the printer actions when print data is received past the forms width setting.

- ENABLE (the default) performs an automatic carriage return and line feed when data is received past the forms width.
- DISABLE discards any data past the forms width.

## Overstrike

The OVERSTRIKE option determines the action required when a line is printed over a previous line because a carriage return was received without a line feed.

- ENABLE (the default) prints the second line on top of the first line.
- DISABLE replaces the characters from the first line with the second line.

## Define LF Code

The DEFINE LF CODE (Define Line Feed Code) option determines whether an automatic carriage return should occur whenever a line feed command is received.

- LF = LF (the default) does not perform an automatic carriage return. The next print position will be the current print position of the next line.
- LF = CR + LF forces an automatic carriage return with each line feed command. The next print position will be position 1 of the next line.

## Printer Select

The PRINTER SELECT option determines if the ASCII DC1 and DC3 control codes can be used to disable and enable the printer.

- DISABLE (the default) ignores the DC1 and DC3 control codes.
- ENABLE disables the printer when a DC1 control code is received, and enables the printer when a DC3 control code is received.

## Alternate Set 80–9F

This option determines if data in the range of hex 80 through hex 9F should be interpreted as a control code or as a printable character.

- CONTROL CODE (the default) interprets data in the range of hex 80 through hex 9F as a control code.
- PRINTABLE prints data in the range of hex 80 through hex 9F.

# Print Format Menu

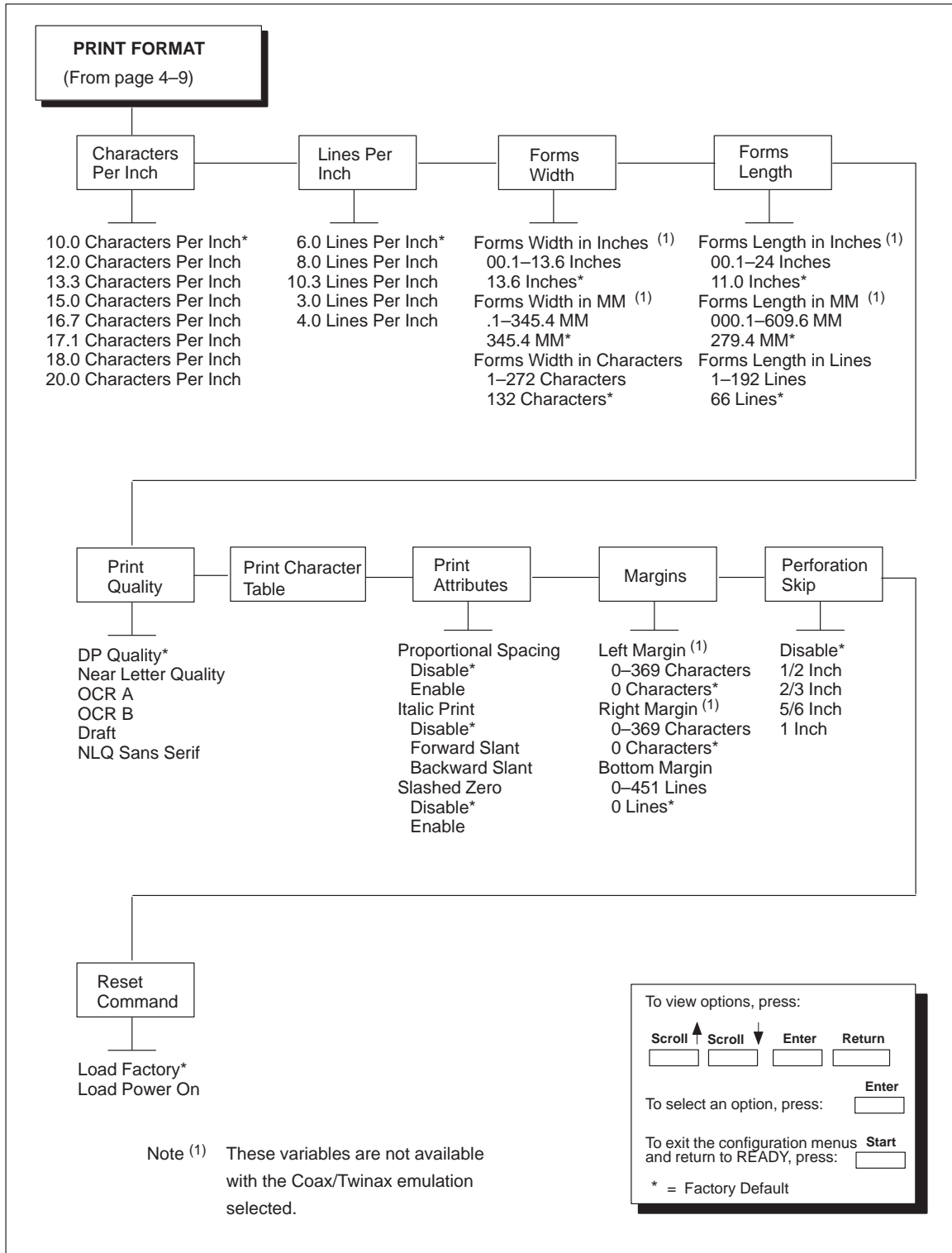

Figure 4-21. Print Format Menu

## Characters Per Inch

CHARACTERS PER INCH (CPI) specifies the number of characters that will print per horizontal inch.

- 10.0 CHARACTERS PER INCH (the default)
- 12.0 CHARACTERS PER INCH
- 13.3 CHARACTERS PER INCH
- 15.0 CHARACTERS PER INCH
- 16.7 CHARACTERS PER INCH
- 17.1 CHARACTERS PER INCH
- 18.0 CHARACTERS PER INCH
- 20.0 CHARACTERS PER INCH

It is possible to specify a CPI value that causes the page width to exceed the maximum physical page width. In this case, the printer automatically changes the page width to the highest valid value for the new CPI.

When OCR A or OCR B is selected as the default print language, 10 CPI is the only available value for this parameter. If a different CPI value is desired, the print language must be changed first.

**NOTE:** Receipt of a data stream control code that specifies a CPI value overrides any value entered via the operator panel.

## Lines Per Inch

LINES PER INCH (LPI) specifies the number of lines that will print per vertical inch.

- 6.0 LINES PER INCH (the default)
- 8.0 LINES PER INCH
- 10.3 LINES PER INCH
- 3.0 LINES PER INCH
- 4.0 LINES PER INCH

It is possible to specify an LPI value that causes the page length to exceed the maximum allowed page length. In this case, the printer automatically changes the page length to the highest valid value for the new LPI.

**NOTE:** Receipt of a data stream control that specifies the LPI value overrides the value entered via the operator panel.

## Forms Width

FORMS WIDTH specifies the forms width in inches, millimeters or characters. All three measurements will update the same configuration parameter. The default values for forms width are 13.6 inches, 345.4 mm and 136 characters.

**NOTE:** The default values for forms width are 13.2 inches, 335.5 mm and 132 characters when P-Series, Coax/Twinax, IGP or Code V are installed.

**NOTE:** FORMS WIDTH IN INCHES and FORMS WIDTH IN MM selections are not available with the Coax/Twinax emulation. The only variable available with the Coax/Twinax emulation is FORMS WIDTH IN CHARACTERS.

Descriptions follow for the three ways of specifying the forms width:

- FORMS WIDTH IN INCHES allows you to input the forms width in inches. Valid values range from 00.1 through 13.6 inches, in increments of .1 inch.
- FORMS WIDTH IN MM allows you to input the forms width in millimeters. Valid values range from .1 through 345.4, in increments of tenths of a millimeter (0.1 mm).
- FORMS WIDTH IN CHARACTERS allows you to input the forms width in characters from 1 to 272 characters. The maximum forms width in characters depends on the current CPI setting; it is equal to the maximum forms width in inches multiplied by the current CPI setting.

For example, at 10 CPI, the maximum forms width is:

$$10 \text{ CPI} \times 13.6 \text{ inches} = 136 \text{ characters.}$$

Only valid forms width values will be accepted. If a width is selected that is larger than the maximum width for the current CPI, then the maximum width will be used. If a larger width value is desired, then the CPI value must be changed first.

**NOTE:** Receipt of a data stream control code that changes the page width overrides the page width previously specified via the operator panel.

The following table lists the maximum number of characters that can be printed for a given Characters Per Inch (CPI) setting.

<b>CPI Setting</b>	<b>Maximum Forms Width (in Characters)</b>
10.0	* 136
12.0	163
13.3	181
15.0	204
16.7	227
17.1	232
18.0	245
20.0	272

\* = Default

#### **IMPORTANT**

**If the forms width is set in characters and the CPI is changed, the effective page width is changed to be equal to the forms width in characters divided by the new CPI. For example, if the current forms width is 132 characters and the CPI is changed from 10 CPI to 15 CPI, the effective forms width changes from 13.2 inches to 8.8 inches.**

**NOTE:** This applies only if the forms width is set in characters. If the forms width is set in inches or millimeters (mm), changing the CPI does not affect the effective forms width.

## Forms Length

FORMS LENGTH specifies the forms length in inches, millimeters or lines. All three measurements will update the same configuration parameter. The default values for forms length are 11 inches, 279.4 millimeters, or 66 lines per page.

Descriptions follow for the three ways of specifying the forms length:

**NOTE:** The actual value displayed for forms length set in inches and mm can be greater than the maximum values listed on the operator panel because the number of lines can exceed actual inches and mm values.

**NOTE:** FORMS LENGTH IN INCHES and FORMS LENGTH IN MM selections are not available with the Coax/Twinax emulation. The only variable available with the Coax/Twinax emulation is FORMS LENGTH IN CHARACTERS.

- FORMS LENGTH IN INCHES allows you to input the forms length in inches. Valid values range from 00.1 through 24 inches, in increments of 0.1 inch. (This option not available for the coax interface.)
- FORMS LENGTH IN MM allows you to input the forms length in millimeters. Valid values range from 000.1 through 609.6 millimeters, in increments of tenths of a millimeter (0.1 mm). (This option not available for the coax interface.)
- FORMS LENGTH IN LINES allows you to input the forms length in lines. The maximum forms length in lines depends on the current LPI setting; it is equal to the maximum forms length in inches multiplied by the current LPI setting.

For example, at 6 LPI the maximum forms length is:

$$6 \text{ LPI} \times 24 \text{ inches} = 144 \text{ lines}$$

Only valid forms length values will be accepted. If you select a length that is larger than the maximum length for the current LPI, the maximum length will be used. If you need a longer page length, you must first change the LPI.

### IMPORTANT

**If the forms length is set in lines and you change the LPI, the effective page length changes to the forms length in characters divided by the new LPI. For example, if the current forms length is 66 lines and you change the LPI from 6 LPI to 8 LPI, then the effective forms length changes from 11 inches to 8.25 inches.**

**NOTE:** This only applies if the forms length is set in lines. If the forms length is set in inches or millimeters, changing the LPI does not affect the effective forms length.

**NOTE:** Receipt of a data stream control code which changes the forms length overrides the forms length previously specified via the operator panel.

## Print Quality

**NOTE:** When using bold or emphasized printing, the printer prints two dots instead of one to produce the desired effect. This does not affect characters per inch.

This parameter specifies the density (quality) of printing:

- DP Quality (the default)
- Near Letter Quality
- OCR A
- OCR B
- Draft
- NLQ Sans Serif

**NOTE:** Receipt of a data stream control sequence that changes the print quality overrides the print quality specified via the operator panel.

Specifying a print *quality* of OCR A or OCR B will change the print *language* to OCR A or OCR B.

When OCR A or OCR B is selected as the default print language, OCR A/OCR B are the only available values for this parameter. If a different print quality value is desired, the print language must be changed first.

## Print Character Table

This parameter prints out a table of the current interface character set.



## Print Attributes

The PRINT ATTRIBUTES parameter is used to determine character and page formatting.

- PROPORTIONAL SPACING uses proportional spacing for text data when enabled.

DISABLE is the default.

ENABLE uses proportional spacing for text data.

**NOTE:** Proportional spacing is only supported in 10 CPI. Therefore, you must select 10 CPI, or proportional spacing will be ignored.

- ITALIC PRINT prints text in italics, when enabled. Both a forward and backwards slanting italic are available.

DISABLE is the default.

FORWARD SLANT uses italic print that slants forward.

BACKWARD SLANT uses italic print that slants backward.

- SLASHED ZERO prints zeros with a slash, when enabled, to distinguish zeros from the alphabetic capital “O.”

DISABLE is the default.

ENABLE prints zeros with a slash.

## Margins

**NOTE:** LEFT MARGIN and RIGHT MARGIN selections are not available with the Coax/Twinax emulation. The only variable available with the Coax/Twinax emulation is BOTTOM MARGIN.

The MARGINS parameter defines where the bottom, left, and right page margins are located.

- LEFT MARGIN defines where print position 1 is located. The left margin is specified as the number of characters from the left edge of the forms. Valid values range from 0 to 369 characters. The default is 0 characters.

- **RIGHT MARGIN** defines where the last print position is located. The right margin is specified as the number of characters from the right edge of the forms. Valid values range from 0 to 369 characters. The default is 0 characters.
- **BOTTOM MARGIN** defines the location of the last print line on the page. The bottom margin is specified as the number of lines from the bottom of forms position. Valid values range from 0 to 451 lines. The default is 0 lines.

## **Perforation Skip**

**PERFORATION SKIP** specifies the amount of paper to skip after printing the last line on the form. If this option is disabled, there is no skip after the last line on the form.

- **DISABLE** (the default)
- **1/2 INCH**
- **2/3 INCH**
- **5/6 INCH**
- **1 INCH**

## **Reset Command**

**Reset Command** specifies the configuration that will be used by the printer after the reset command is issued.

- **Load Factory** will load the factory default configuration for printer use. This is the default selection.
- **Load Power On** will load the selected power on configuration for printer use.

## Operator Print Tests Menu

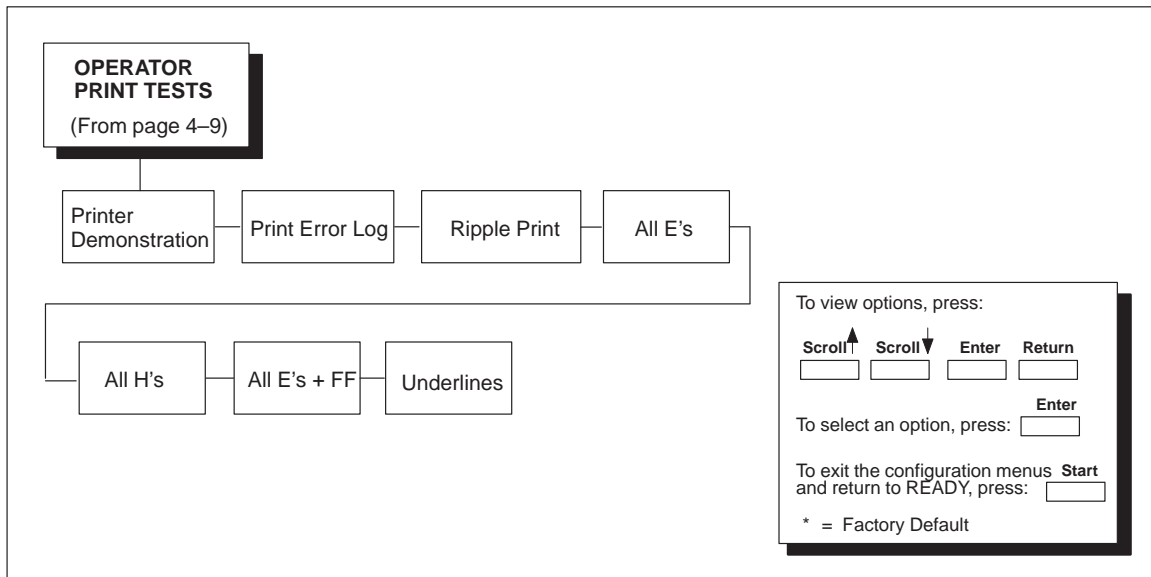

**Figure 4–22. Operator Print Tests Menu**

The print tests are used to check the print quality and operation of your printer. The procedure to run these tests is shown on page 6–8. The self-tests include the following:

- **Printer Demonstration** — Demonstrates all the functions and features available on the printer.
- **Print Error Log** — Prints a log of errors that have occurred in the printer.
- **Ripple Print** — A “sliding” alphanumeric pattern used to identify missing or malformed characters, improper vertical alignment, or vertical compression.
- **All E’s** — A pattern of all uppercase E’s that identifies missing characters, misplaced dots, smeared characters, improper phasing problems, or light/dark character variations.
- **All H’s** — A pattern of all uppercase H’s used to detect missing characters, misplaced dots, smeared characters, or improper phasing.
- **All E’s + FF** — A pattern of all E’s repeated for ten lines and followed by a form feed to the next page top-of-form, used to identify paper motion or feeding problems, such as paper path obstruction or improper forms.
- **Underlines** — An underline pattern useful for identifying hammer bank misalignment.

**NOTE:** Your IBM Customer Service Representative will typically run these tests.

## Printer Information Menu

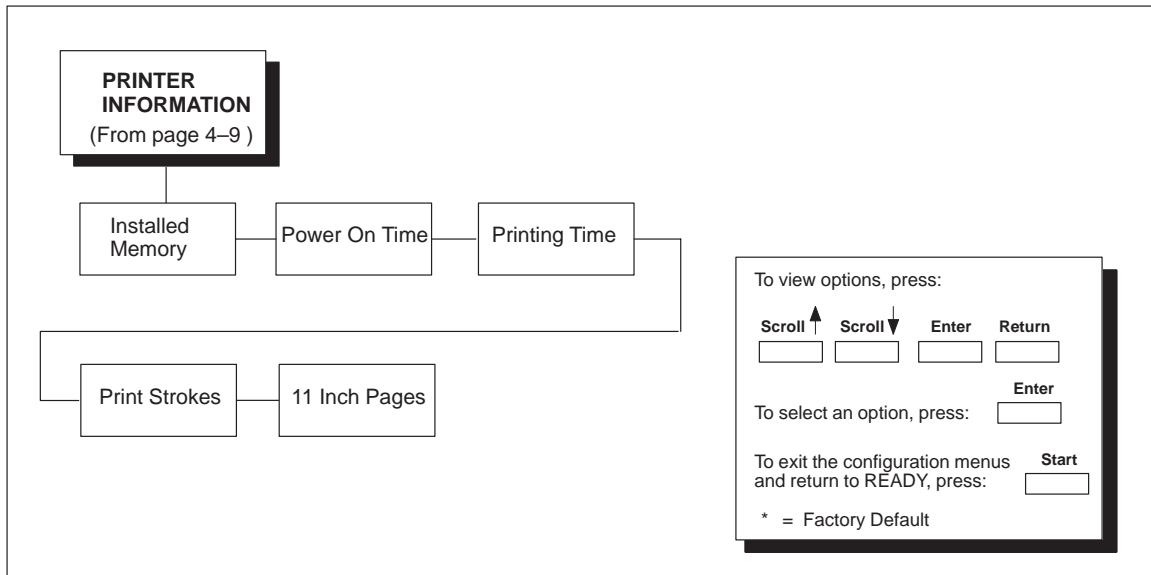

**Figure 4-23. Printer Information Menu**

You can view various printer statistics, such as hours of usage, and refer to these figures for preventive maintenance purposes. Printer statistics accumulate continuously; they do not reset when you power off the printer.

All of the printer statistics are set to zero at the factory after burn-in testing.

**Installed Memory** Displays the amount of RAM installed in the printer in megabytes.

**Power-on Time:** The cumulative time in hours the printer has been powered on. The range is 0 to 30,000 hours.

**Printing Time:** The cumulative time in hours the printer has actually been printing. The range is 0 to 30,000 hours.

**Print Strokes:** The cumulative number of back-and-forth shuttle strokes the printer has printed during normal operation. The range is 0 to 4,000,000,000 shuttle strokes.

**11 Inch Pages** The cumulative number of pages the printer has printed. The range is 0 to 363,000,000 pages.

# RIBBONMINDER Menu

RibbonMinder™ monitors ink consumption to ensure quality printing. The “RibbonMinder” chapter explains how to use this feature and its options in more detail.

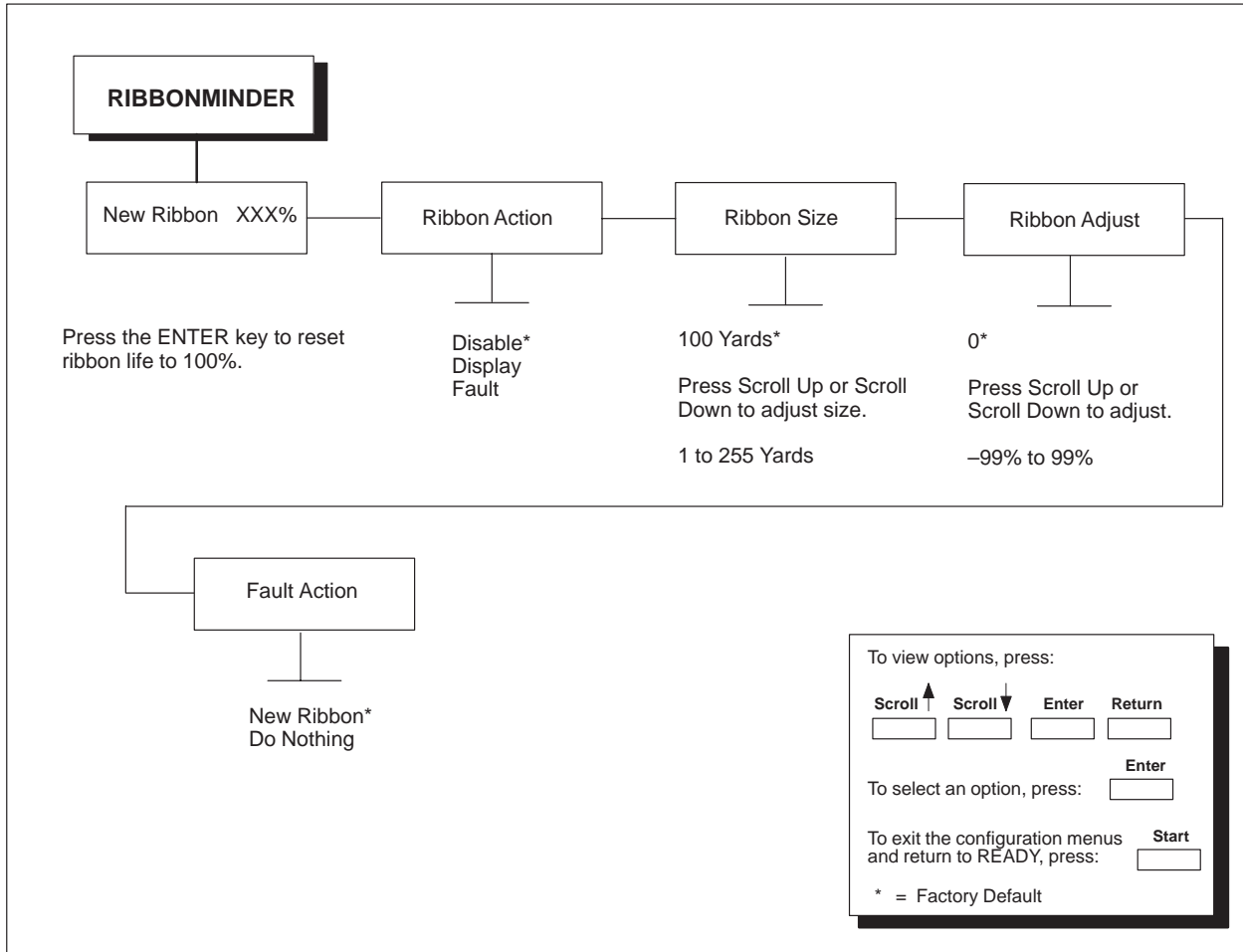

Figure 4–24. Ribbon Life Menu

## New Ribbon

Whenever you install a new ribbon, and are using the RibbonMinder feature, the ribbon life must be reset to 100%. You can reset the ribbon life to 100% from the operator panel using the New Ribbon option by pressing the **Enter** key.

## Ribbon Action

This option allows you to perform three functions:

- **DISABLE** does not display the RibbonMinder ink consumption percentage. The percentage is calculated but not displayed.
- **DISPLAY** allows you to view the RibbonMinder ink consumption display.
- **FAULT** displays an error message, which is Ribbon Ink Out, Change Ribbon, when the RibbonMinder consumption percentage falls below zero. The error message can be cleared and printing can continue for approximately another two minutes. If either the RibbonMinder is not reset or a new ribbon is not installed, an error message will be displayed again.

## Ribbon Size

You can use the Ribbon Size option to specify the ribbon length in increments of one yard.

- Minimum size is 1 yard and maximum size is 255 yards. (Default is 100 yards.) Although you can enter a number between 1 and 255, you should make sure the number matches the ribbon size, which is either 60 or 100 yards. Therefore, you would enter either 60 or 100.

## Ribbon Adjust

Enables you to print more or less pages before the display reaches 0%. Refer to Chapter 7, “RibbonMinder™”, for more information.

- The setting can range from -99% to 99%. 0% is the default.

## Fault Action

Allows you to select the way the fault message will be reset.

- **NEW RIBBON** allows that if the Ribbon Out of Ink, Change Ribbon message is displayed, when you open the platen to change the ribbon, the ribbon life is reset to 100 percent.
- **DO NOTHING** allows that the ribbon life may only be reset via the New Ribbon menu option.

# 5 Printer Interfaces

## Chapter Contents

---

Overview .....	5-2
RS-232 and RS-422 Serial Interfaces .....	5-3
RS-232 and RS-422 Serial Interface Signals .....	5-4
RS-232 Serial Interface Protocols .....	5-5
RS-232 and RS-422 Serial Interface Protocols .....	5-5
RS-232 and RS-422 Serial Interface Error Handling .....	5-5
RS-232 and RS-422 Serial Interface Configuration .....	5-6
PC Parallel Interface .....	5-7
PC Parallel Interface Signals .....	5-8
PC Parallel Interface Configuration .....	5-9
Dataproducts Parallel Interface .....	5-10
Dataproducts Parallel Interface Signals .....	5-11
Dataproducts Parallel Interface Configuration .....	5-12
IEEE 1284 Parallel Interface .....	5-13
Operating Modes .....	5-13
The Negotiation Phase .....	5-14
Signals .....	5-14
Terminating Resistor Configurations .....	5-17

## Overview

---

The printer interface is the point where the data line from the host computer plugs into the printer. The interface processes all communications signals and data to and from the host computer. The printer interface consists of a printed circuit board assembly (PCBA) and a cable connector for the data line. Communication signals and data may be sent over parallel or serial lines.

Each IBM 6400 printer is equipped with three parallel interface protocols and two serial interface protocols. Coax and twinax interface protocols are available as features. Each interface is selected via the operator panel configuration menu. (Refer to Chapter 3, “Configuring the Printer.”)

This chapter describes the interfaces provided with the printer. In addition, instructions are provided for configuration of terminating resistors.

- RS-232 serial
- RS-422 serial
- PC Parallel
- Dataproducts parallel
- IEEE 1284



## RS–232 and RS–422 Serial Interfaces

---

**NOTE:** The RS–232 and RS–422 serial interface circuit characteristics are compatible with the Electronic Industry Association Specifications EIA–232–E and EIA–422–A.

The RS–232 and RS–422 serial interfaces enable the printer to operate with bit serial devices that are compatible with an RS–232 controller. The input serial data transfer rate (in baud) is selectable from the printer operator panel. Baud rates of 600, 1200, 2400, 4800, 9600, 19,200, 38,400, 57,600, and 115,200 are available.

The input format consists of a single start bit, 7 or 8 data bits, and one or two stop bits. The number of data bits is determined by printer configuration. The data bits are interpreted with the least significant bit first. Parity checking is determined by printer configuration options selected from the operator panel.

The printer interface uses a first-in/first-out buffer. The asynchronous interface accepts data as it is provided by the host. The length of the data cable from the host computer to the printer must not exceed 50 feet (15 meters) for RS–232 interfaces and 400 feet (120 meters) for RS–422 interfaces.

**Table 5–1. RS–232 Serial Interface Connector Pin Assignments**

Input Signals		Output Signals		Miscellaneous	
Signal	Pin	Signal	Pin	Signal	Pin
Received Data (RD)	3	Transmit Data (TD)	2	Chassis Ground	1
Clear To Send (CTS)	5	Request To Send (RTS)	4	Signal Ground	7
Data Set Ready (DSR)	6	Data Terminal Ready (DTR)	20		
Data Carrier Detect (DCD)	8				

**Table 5–2. RS–422 Serial Interface Connector Pin Assignments**

Input Signals		Output Signals		Miscellaneous	
Signal	Pin	Signal	Pin	Signal	Pin
– Receive Data (–RD)	15	– Transmit Data (–TD)	19	Chassis Ground	1
+ Receive Data (+RD)	17	+ Transmit Data (+TD)	25	Signal Ground	7

## RS-232 and RS-422 Serial Interface Signals

The RS-232 connector mounted on the printer is a 25-pin DB-25S type. The mating connector is a DB-25P. RS-232 and RS-422 compatible serial interface signals are defined as follows:

### RS-232:

**Received Data (RD)** — Serial data stream to the printer.

**Transmitted Data (TD)** — Serial data stream from the printer for transmitting status and control information to the host. Subject to protocol selection.

**Request To Send (RTS)** — Control signal from the printer. Subject to configuration.

**Clear To Send (CTS)** — Status signal to the printer indicating the host is ready to receive data/status signals from the printer.

**Data Set Ready (DSR)** — Status signal to the printer indicating the host is in a ready condition.

**Data Carrier Detect (DCD)** — Status signal to the printer. The ON condition is required for the printer to receive data.

**Data Terminal Ready (DTR)** — Control signal from the printer. Subject to configuration.

### RS-422:

**+RD, -RD** — Serial data stream differentially received by printer.

**+TD, -TD** — Differentially driven serial data stream for transmitting status and control information to the host. Subject to protocol selection.

**NOTE:**  $\pm$ RD and  $\pm$ TD form signal and return paths of a differential line signal.

## RS-232 Serial Interface Protocols

**DTR** — (DTE Ready). The printer controls the data flow by asserting or de-asserting this hardware signal to the host. If there is enough room in the printer buffer, the printer will send a high signal; if the buffer is full the printer will send a low signal. DTR tells the host if it is safe to send more data. (If the host sends data during an unsafe condition, data will be lost.)

## RS-232 and RS-422 Serial Interface Protocols

**X-ON / X-OFF** — Transmit On / Transmit Off. The printer transmits an X-ON character (hex 11) when entering the Ready mode or when the buffer is almost empty. The printer transmits an X-OFF character (hex 13) when entering the Not Ready mode or when the buffer is almost full.

**ETX / ACK** — End of Text / Acknowledge. The host controls the flow of communication to the printer by sending a block of data and ending the block with an End of Text (ETX) signal. When the printer receives the ETX signal, it will acknowledge it has received the entire block of data.

**ACK / NAK** — Acknowledge / Negative Acknowledge. ACK means acknowledge; the device acknowledges it has accepted a transmission. NAK means a negative acknowledge; the device did not receive the transmission.

## RS-232 and RS-422 Serial Interface Error Handling

**NOTE:** All serial errors are treated as faults that require operator intervention.

**Parity Error Handling** — Parity error checking is a configuration option selected from the operator panel.

With odd or even parity checking selected, a character with a parity error is replaced with a question mark (?) character.

When parity checking is not selected (“NONE” on the operator panel), parity errors are ignored and the characters are printed as received.

**Framing Error Handling** — Framing error checking is always in effect for the serial interface.

When a framing error occurs, an exclamation point (!) is printed. If 20 successive errors are received, a line feed is added to force printing to occur.

**Overrun Error Handling** — Overrun error checking is always in effect for the serial interface.

When a data overrun error occurs, an asterisk (\*) is printed. If 20 successive errors are received, a line feed is added to force printing to occur.

## **RS–232 and RS–422 Serial Interface Configuration**

Your printer is configured at the factory to match the interface you specified. By using the operator panel, you may verify and change several interface parameters in order to meet specific application requirements.

Refer to Chapter 4, “Configuration Menus,” for RS–232 and RS–422 parameter descriptions and information on selecting values for the following parameters:

### **RS–232 and RS–422:**

- Baud Rate (data rate selected from the operator panel)
- Data Bits (7 or 8 Bits)
- Stop Bits (1 or 2 Bits)
- Parity (None, Odd, Even, Mark or Sense)

### **RS–232 only:**

- Data Terminal Ready logic
- Request to Send logic

Some application programs require a unique configuration. If the printer is not working properly in the configuration you selected, contact an IBM service representative.

### **One Char Enquiry**

When enabled, and the IGP feature is available, a status byte is sent back to the host when the poll character or the command SFCC enquiry is sent to the printer (serial interface only). The poll character is received and the status byte is sent whether the printer is online or offline. The SFCC enquiry will only be processed when the printer is online.

### **Poll Character**

This option is used when One Char Enquiry is enabled and the IGP feature is available. Whenever the printer receives this character, it sends a response to the host indicating the current state of the printer. It may be configured from 0 to 255. The default value is 0.

## PC Parallel Interface

---

The PC Parallel interface (also referred to as the “Centronics” interface) enables the printer to operate with controllers designed for buffered PC Parallel printers. The length of the data cable from the host computer to the printer must not exceed 15 feet (5 meters).

**NOTE:** For a more reliable data transfer, a maximum cable length of six feet is recommended.

**Table 5–3. Printer PC Parallel Interface Connector Pin Assignments**

Input Signals		Output Signals		Miscellaneous	
Signal	Pin	Signal	Pin	Signal	Pin
DATA LINE 1	2	ACKNOWLEDGE	10	CHASSIS GROUND	17
Return	20	Return	28		
DATA LINE 2	3	ONLINE/SELECT	13	GROUND (GND)	16, 30
Return	21	Fault	32		
DATA LINE 3	4	PAPER EMPTY	12	(NC)	34
Return	22	Return	30		
DATA LINE 4	5	BUSY	11		
Return	23	Return	29		
DATA LINE 5	6	NAUTO FEED	14		
Return	24				
DATA LINE 6	7	NINIT (PRIME)	31		
Return	25				
DATA LINE 7	8	NOT DATAPRODUCTS*	35		
Return	26				
DATA LINE 8	9	EXTERNAL 5 VOLTS	18		
Return	27				
DATA STROBE	1	N SELECT	36		
Return	19				
PAPER INSTRUCTION	15				
Return	33				

\* Used by DP adapter.

## PC Parallel Interface Signals

The PC Parallel interface signals between the host computer and the printer are defined as follows:

**Data Lines 1 through 8** — Provide eight standard or inverted levels from the host that specify character, data, plot data, or function code. Data Line 8 allows access to the extended ASCII character set. You may enable or disable this line via the Data Bit 8 parameter on the System Interface Parameters and PC Parallel submenus.

**Data Strobe** — Carries a low true, 100 ns min. pulse from the host that clocks data into the printer.

**Paper Instruction (PI)** — Carries a VFU control signal from the host with the same timing as the data lines.

**Acknowledge** — A low true pulse from the printer indicating the character or function code has been received and the printer is ready for the next data transfer.

**Online/Select** — A high true level from the printer to indicate the printer is ready for data transfer and the **Start** key on the operator panel has been activated. When the printer is in Ready mode, it may accept data from the host.

**Paper Empty (PE)** — A high true level from the printer to indicate the printer is in a fault condition.

**Busy** — A high true level from the printer to indicate the printer cannot receive data.

## PC Parallel Interface Configuration

Your printer is configured at the factory to match the interface you specified. By using the operator panel, you may verify and change several interface parameters in order to meet specific application requirements.

Refer to Chapter 4, “Configuration Menus,” for PC Parallel parameter descriptions and information on selecting values for the following parameters:

- Data Bit 8 (enable or disable)
- Data Polarity (standard or inverted)
- Strobe Polarity (standard or inverted)
- Response Polarity (standard or inverted)
- Busy on Strobe (enable or disable)
- Latch Data On Leading or Trailing Edge of Strobe
- Prime Signal (enable or disable)
- TOF Action at Prime Signal (do nothing or form feed)
- Buffer Size in kilobytes (1 to 16)

Some application programs require a unique configuration. If the printer is not working properly in the configuration you have selected, contact an IBM service representative.

## Dataproducts Parallel Interface

---

The Dataproducts parallel interface allows the printer to operate with a 50-pin Amplimite (AMP) HDH-20 data cable connector. This adapter can be obtained as a feature on the 6400. The length of the data cable from the host computer to the printer must not exceed 40 feet (12 meters).

**Table 5-4. Dataproducts Parallel Interface Connector Pin Assignments  
(with a 50-pin AMP HDH-20 Data Cable Connector)**

Input Signals		Output Signals		Miscellaneous	
Signal	Pin	Signal	Pin	Signal	Pin
DATA LINE 1	19	READY	22	CABLE VERIFY	45, 46
Return	3	Return	6		
DATA LINE 2	20	ONLINE	21	GROUND	39
Return	4	Return	5		
DATA LINE 3	1	DEMAND/DATA REQUEST	23		
Return	2	Return	7		
DATA LINE 4	41				
Return	40				
DATA LINE 5	34				
Return	18				
DATA LINE 6	43				
Return	42				
DATA LINE 7	36				
Return	35				
DATA LINE 8	28				
Return	44				
DATA STROBE	38				
Return	37				
PAPER INSTRUCTION	30				
Return	14				

Note: Pins not listed are not connected.



## Dataproducts Parallel Interface Signals

Dataproducts-compatible interface signals between the host computer and the printer are defined as follows:

**Data Lines 1 through 8** — Provide eight standard or inverted levels from the host that specify character data, plot data, or a control code. Data Line 8 allows access to the extended ASCII character set. You may enable or disable this line via the Data Bit 8 parameter on the System Interface Parameters and Dataproducts submenus.

**Data Strobe** — Carries a high true pulse from the host when data is ready. The data strobe remains high until the Data Request line goes false. The active edge of the strobe signal can be configured as leading (default) or trailing.

**Paper Instruction (PI)** — Carries a DAVFU signal from the host with the same timing and polarity as the data lines.

**Ready** — Carries a high true signal from the printer when AC power and DC voltages are present, paper is loaded properly, and the printer is not in a check condition.

**Online** — Carries a high true signal from the printer when the Ready Line is true and the **Start** key on the operator panel has been activated. When the printer is in Ready mode, it may accept data from the host.

**Demand/Data Request** — Carries a high true signal from the printer when the printer is ready to accept character data from the host. This signal changes to false shortly after the leading edge of the data strobe signal.

**Cable Verify** — Two pins on the interface connector are jumpered together to allow the user to verify proper installation of the interface connector.

## Dataproducts Parallel Interface Configuration

Your printer is configured at the factory to match the interface you specified. By using the operator panel, you may verify and change several interface parameters in order to meet specific application requirements.

Refer to Chapter 4, “Configuration Menus,” for Dataproducts parameter descriptions and information on selecting values for the following parameters:

- Data Bit 8 (enable or disable)
- PI Ignored (enable or disable)
- Data Polarity (standard or inverted)
- Data Request Polarity (standard or inverted)
- Strobe Polarity (standard or inverted)

Some application programs require a unique configuration. If the printer is not working properly in the configuration you have selected, contact an IBM service representative.

## IEEE 1284 Parallel Interface

---

The IEEE 1284 is a parallel interface with bidirectional capabilities. Features include the following:

- Faster data transmission. Timing of the signals has been reduced.
- Bidirectional communication. Both the host and the printer can send data.
- Versatility. If a device cannot send data along particular lines, the 1284 can circumvent this and send data via other operating modes, such as Nibble Mode which is discussed later.
- Less user interaction. The host can ask the printer about printing status and supported features, such as fonts and internal errors. For example, instead of having to physically check if the printer has run out of paper, you can create a program to query this from the host. The printer will respond and a message will display on the host.

### Operating Modes

The 1284 supports three operating modes, which are determined by negotiation between the printer and the host.

#### Compatibility Mode

This mode provides compatibility with a Centronics or PC Parallel interface. Data is transferred from the host to the printer in 8-bit bytes over the data lines.

Compatibility Mode can be combined with Nibble and Byte Modes to provide bidirectional communication.

#### Nibble Mode

Eight bits equals one byte. When a byte of data is sent to the printer, the eight bits are sent over eight data lines.

Some devices cannot send data over their eight data lines. To bypass this, the 1284 permits data to be sent as half a byte over four status lines. (Half a byte equals one nibble.) Two sequential four-bit nibbles are sent over the lines.

Data is transferred from printer to host in four-bit nibbles over the status lines, and the host controls the transmission.

## Byte Mode

The printer and host send data to each other along eight data lines (one bit per line).

If bidirectional communication is supported by the printer and the host, the host will take control of the data transfer.

## The Negotiation Phase

The negotiation phase determines which operating mode will be used. At this time, the host and the printer will sense what devices are attached, the supported signals available, and which mode to use. The selected mode, in turn, defines the pins on the 1284 connector.

There are 36 pins on the parallel interface. Each one sends a different signal. Pin 1, for example, can send a Strobe signal or a HostClk signal, depending on the mode selected. Table 5-5 on page 5-15 shows the different definitions.

## Signals

1284 interface signals between the host and the printer are defined below.

Host Clock / nWrite – Driven by host. Data transferred from host to printer. When printer sends data, two types are available. If Nibble Mode, signal is set high. If Byte Mode, signal is set low.

Data 1 through Data 8 – These pins are host-driven in Compatibility Mode and bidirectional in Byte Mode. They are not used in Nibble Mode. Data 1 is the least significant bit; Data 8 is the most significant bit.

Printer Clock / Peripheral Clock / Interrupt – Driven by the printer. A signal from the printer indicating the character or function code has been received and the printer is ready for the next data transfer.

Printer Busy / Peripheral Acknowledge / nWait – Driven by the printer. Indicates the printer cannot receive data. (Data bits 4 and 8 in Nibble Mode.)

Acknowledge Data Request / nAcknowledge Reverse – Driven by the printer. Indicates the printer is in a fault condition. (Data bits 3 and 7 in Nibble Mode.)

Xflag – Driven by the printer. A high true level indicating the printer is ready for data transfer and the printer is on-line. (Data bits 2 and 6 in Nibble Mode.)

Host Busy / Host Acknowledge / NDStrobe – Driven by the host. Activates auto–line feed mode.

Peripheral Logic High – Driven by the printer. When pulsed high, the printer indicates all of its signals are in a valid state. When pulsed low, the printer indicates its power is off or its signals are in an invalid state.

nReverse Request – Driven by the host. Resets the interface and forces a return to Compatibility Mode idle phase.

nData Available / nPeripheral Request – Driven by the printer. Indicates the printer has encountered an error. (Data bits 1 and 5 in Nibble Mode.)

1284 Active / nAStrobe – Driven by the host. A peripheral device is selected.

Host Logic High – Driven by the host. When set to high, the host indicates all of its signals are in a valid state. When set to low, the host indicates its power is off or its signals are in an invalid state.

nInit – Resets init interface from the host.

Note that the length of the data cable from the host computer to the printer should not exceed 5 meters (15 feet). For greater data reliability, use a cable of 1.8 meters (6 feet) or less.

**Table 5–5. Printer 1284 Connector Signals**

Pin	Source of Data	Type of Mode		
		Compatible	Nibble	Byte
1	Host	nStrobe	HostClk	Host/Clk
2	Host/Printer	Data 1 (LSB)		
3	Host/Printer	Data 2		
4	Host/Printer	Data 3		
5	Host/Printer	Data 4		
6	Host/Printer	Data 5		
7	Host/Printer	Data 6		
8	Host/Printer	Data 7		
9	Host/Printer	Data 8 (MSB)		
10	Printer	nAck	PtrClk	PtrClk
11	Printer	Busy	PtrBusy	PtrBusy
12	Printer	PError	AckDataReq	AckDataReq
13	Printer	Select	Xflag	Xflag
<i>(continued next page)</i>				

**Table 5–5. 1284 Signals (continued)**

Pin	Source of Data	Type of Mode		
		Compatible	Nibble	Byte
14	Host	nAutoFd	Host Busy	HostAck
15		Not Defined		
16		Logic Gnd		
17		Chassis Gnd		
18	Printer	Peripheral Logic High		
19		Signal Ground (nStrobe)		
20		Signal Ground (Data 1)		
21		Signal Ground (Data 2)		
22		Signal Ground (Data 3)		
23		Signal Ground (Data 4)		
24		Signal Ground (Data 5)		
25		Signal Ground (Data 6)		
26		Signal Ground (Data 7)		
27		Signal Ground (Data 8)		
28		Signal Ground (PErrror, Select, nAck)		
29		Signal Ground (Busy, nFault)		
30		Signal Ground (nAutoFd, nSelectIn, nInit)		
31	Host	nInit		
32	Printer	NFault	nDataAvail	aDataAvail
33		Not Defined		
34		Not Defined		
35		Not Defined		
36	Host	nSelectIn	1284 Active	1284 Active

## Terminating Resistor Configurations

---

The factory equips the printer with several resistors that are used for parallel interface configurations and are suitable for most applications. These 470 ohm pull-up and 1K ohm pull-down terminating resistors are located at RP1 and RP2, shown in Figure 5-1.

If the values of these terminating resistors are not compatible with the particular interface driver requirements of your host computer, you may need to install resistors with different pull-up and pull-down values. Possible terminating resistor combinations are shown in the table below. See the *6400 Line Matrix Printer Maintenance Information Manual* for installation procedures.

<b>Configuration</b>	<b>RP1 (Pull-Up)</b>	<b>RP2 (Pull-Down)</b>
Factory Default	470 ohm	1K ohm
Alternate 1	220 ohm	330 ohm
Alternate 2	1K ohm	none

**CMX  
Controller  
Board**

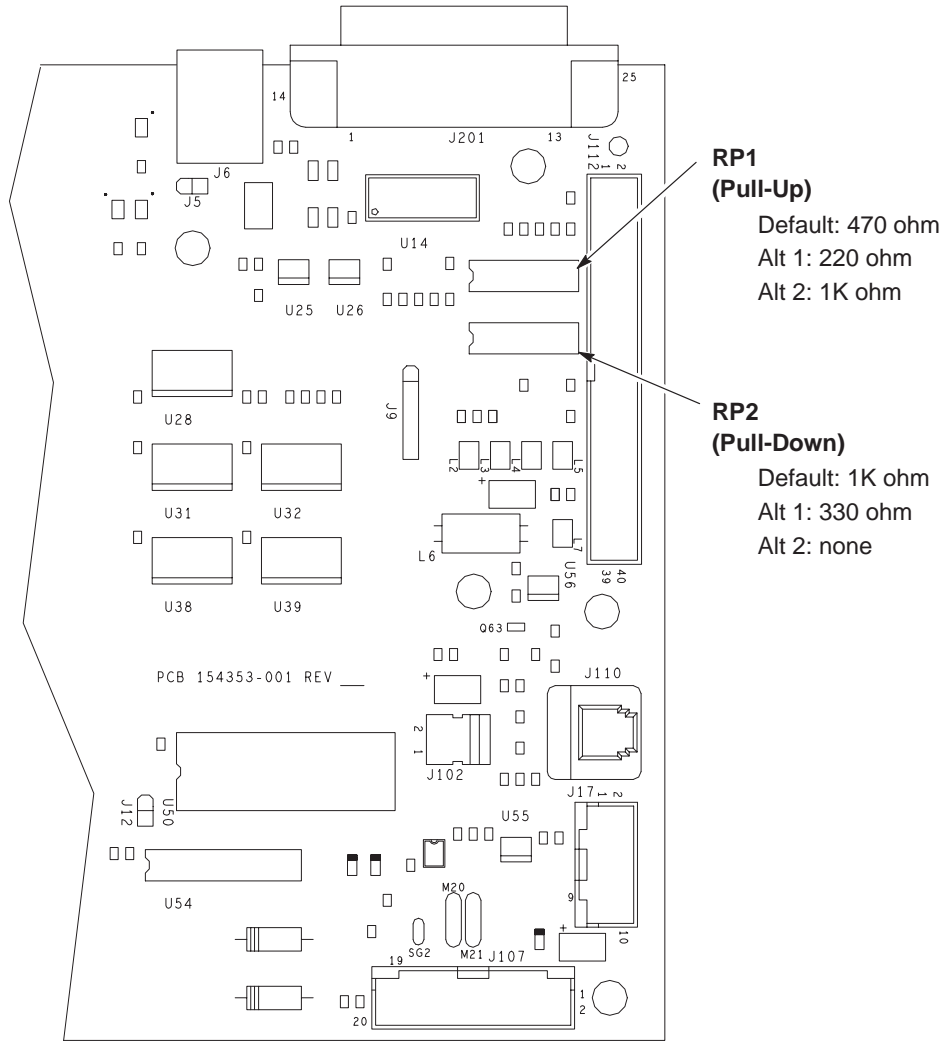

**Figure 5-1. Terminating Resistor Locations**



# 6

## Routine Service and Diagnostics

### Chapter Contents

---

Overview .....	6-2
Cleaning Requirements .....	6-2
Cleaning the Outside of the Cabinet .....	6-2
Cleaning Inside the Cabinet .....	6-3
Printer Self-Tests .....	6-7
Running the Printer Self-Tests .....	6-8
Hex Code Printout .....	6-10
Fault Messages .....	6-14

## Overview

---

This chapter discusses general cleaning, running diagnostic tests, and understanding fault messages.

The printer requires no routine maintenance beyond regular cleaning. Periodically remove excess paper chaff and dust from the ribbon and paper paths. If print quality or paper motion deteriorates seriously even after cleaning, contact your IBM service representative for prompt attention.

## Cleaning Requirements

---

Periodic cleaning ensures efficient operation and clear print quality. If the printer is located in a dusty area or is used for heavy duty printing, clean it more often.

### **DANGER**

**<3> Disconnect the AC power cord before cleaning the printer.**

### **Cleaning the Outside of the Cabinet**

Clean the outside of the cabinet with a soft, lint-free cloth and mild detergent soap. (Dishwashing liquid works well.) Do not use abrasive powders or chemical solvents. Clean the windows with plain water or mild window cleaner.

### **WARNING**

**<5> Always apply the cleaning solution to the cloth; never pour cleaning solution directly onto the printer.**

## Cleaning Inside the Cabinet

Over time, particles of paper, ink, and ribbon accumulate inside impact printers. This is normal. These particles must be removed periodically to avoid degraded print quality. Most paper particles accumulate around the ends of the platen and ribbon path.

To clean the interior of the printer, refer to Figure 6–1 (cabinet models) or Figure 6–2 (pedestal models) and perform the following steps:

1. Power off the printer and unplug the printer power cord.
2. Unload the paper (explained in the *Operator's Guide*).
3. Unlatch both ribbon spools and carefully lift them off the hubs. Raise the ribbon out of the ribbon path.
4. Using a soft-bristled non-metallic brush, remove paper, ribbon, and dust particles from the paper path, ribbon guides, and ribbon path.
5. Brush and vacuum accumulated paper, ribbon, and dust particles, especially in the tractor, hammer bank, and base pan areas.

### WARNING

**<3> Vacuum carefully around the hammer bank and surrounding area to avoid damage.**

6. Wipe the splined shaft with a soft cloth.
7. Check the ribbon mask and hammer bank cover for pieces of torn paper or ribbon lint. Check the holes in the ribbon mask surrounding each hammer tip. Gently remove paper or lint particles with a wooden stick or pair of tweezers. Do not pry or apply force to the hammer tips.
8. Using a soft cloth lightly moistened with anhydrous alcohol, remove dust and ink from the platen and the ribbon guides. (The platen is the thick silver bar behind the hammer bank cover that rotates when the forms thickness lever is rotated.)

### WARNING

**<4> Do not let anhydrous alcohol drip into the hammer bank.**

9. Cabinet models: Brush and vacuum up dust or residue that has accumulated inside the lower cabinet.

10. Cabinet models: Wipe the lower cabinet interior with a clean, lint-free cloth dampened with water and mild detergent. Dry the lower cabinet interior by wiping it with a clean, dry, lint-free cloth.
11. Cabinet and Pedestal models: Install the ribbon (page 2-28), load the paper (page 2-35), and set the top-of-form (page 2-47).

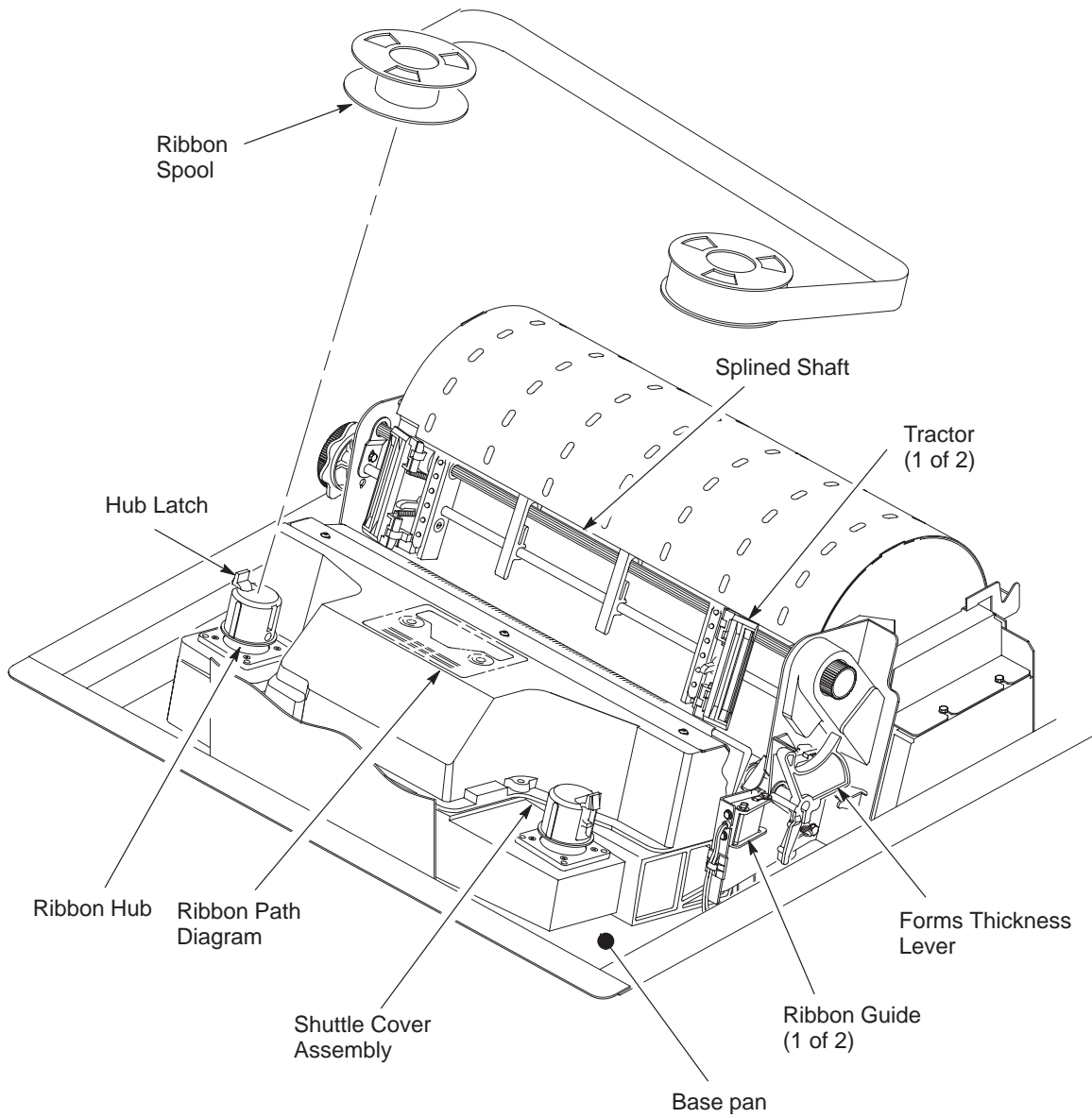

**Figure 6-1. Cleaning the Printer, Cabinet Models**

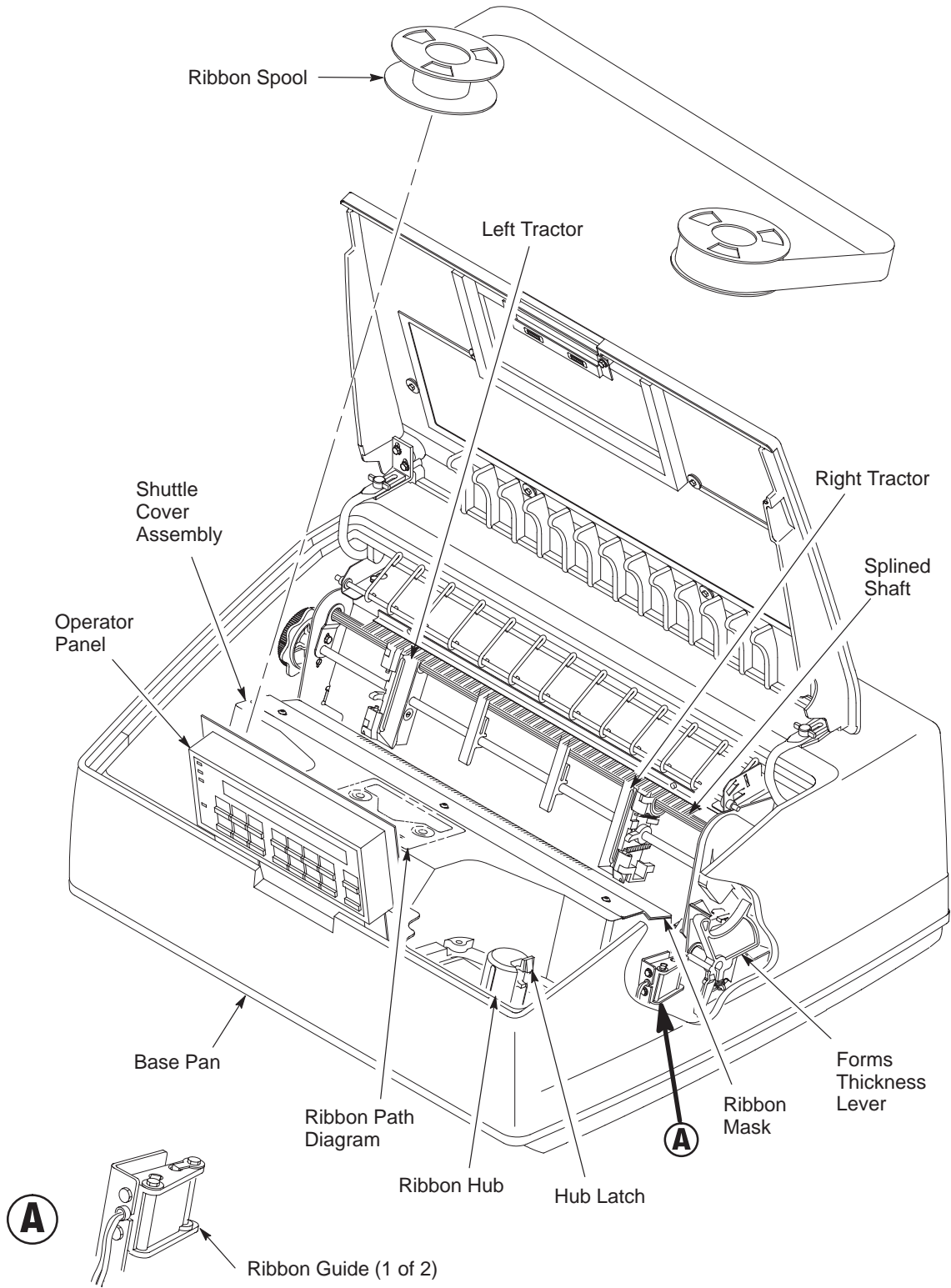

**Figure 6-2. Cleaning the Printer, Pedestal Models**

## Printer Self-Tests













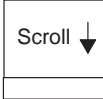

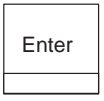

---

With the exception of testing the interface between the printer and the host computer (and the associated data cable), you do not need to send data from the host computer to the printer to test printer operation. You can use the printer's built-in diagnostic tests to check many of the functions of your printer, including print quality and overall operation. These diagnostic tests include the following:

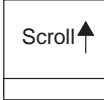
- **Printer Demonstration**  
Demonstrates all the functions and features available on the printer.
- **Print Error Log**  
This test prints the contents of the printer's internal error log.
- **Ripple Print**  
A "sliding" alphanumeric pattern used to identify missing or malformed characters, improper vertical alignment, or vertical compression.
- **All E's**  
A pattern of all uppercase letter E's used to identify missing characters, misplaced dots, smeared characters, improper phasing, or light/dark character variations.
- **All H's**  
A pattern of all uppercase letter H's used to detect missing characters or dots, smeared characters, or improper phasing.
- **All E's + FF (Form Feed)**  
A pattern of all uppercase E's repeated for ten lines and followed by a form feed to the next page top-of-form, used to identify paper motion or feeding problems, such as paper path obstruction or improper forms.
- **Underlines**  
An underline pattern useful for identifying hammer bank misalignment.

**NOTE:** The Operator Print Test menu is displayed in Chapter 4, *Configuration Menus*, on page 4-81.

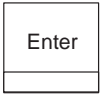
## Running the Printer Self-Tests

Step	Key	Result	Notes
1.	Make sure that the ribbon is installed and the printer is powered on and loaded with paper.		
2.	Press: 		Places the printer in Not READY mode.
3.	 + 		Press both keys at the same time. Unlocking the Operator Menu allows you to test your printer.
4.			First of the series of configuration menus.
5.	 UNTIL		Advances to the OPERATOR PRINT TESTS menu.
6.			Advances to PRINTER DEMONSTRATION, the first option in OPERATOR PRINT TESTS menu.
7.	 UNTIL		Cycles through the list of print tests until you reach the name of the test you wish to run.
8.			The print test you have selected starts printing at either 80 or 136 columns, as specified.
9.			The print test stops printing.



Step	Key	Result	Notes
10.	Examine the print quality of the characters. They should be fully formed and of uniform density. If the test does not run or if text characters do not appear correctly formed, contact your IBM service representative.		
11.	<div style="border: 1px solid black; padding: 2px; display: inline-block;">Stop</div>	<div style="border: 1px solid black; padding: 2px; display: inline-block;">NOT READY</div>	Returns the printer to the NOT READY mode.
12.	<div style="display: inline-block; border: 1px solid black; padding: 2px;">Scroll ↑</div> + <div style="display: inline-block; border: 1px solid black; padding: 2px;">Scroll ↓</div>	<div style="border: 1px solid black; padding: 2px; display: inline-block;">OPERATOR MENU LOCKED</div>	Locks Program mode and the Operator Menu.
13.	<div style="border: 1px solid black; padding: 2px; display: inline-block;">Start</div>	<div style="border: 1px solid black; padding: 2px; display: inline-block;">READY</div>	Returns the printer to the READY mode.

## Hex Code Printout

---

A hex code printout (or hex dump) lists each ASCII/EBCDIC data character received from the host computer, along with its corresponding two-digit hexadecimal code. Hex dumps can be used to troubleshoot some types of printer data reception problems.







To convert an ASCII/EBCDIC character to its corresponding hex code (or vice-versa), refer to the ASCII code chart in the *6400 ASCII Programmer's Reference Manual*, or the EBCDIC code chart in the *6400 Coax/Twinax Programmer's Reference Manual*.





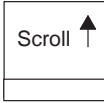
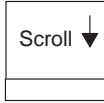

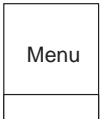
Each printable character prints both as its assigned symbol and as its hex equivalent. Each nonprintable character prints both as a period (.) and as its hex equivalent.



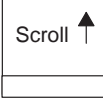



When using a parallel interface, the letter “p” before a hex code indicates an active Paper Instruction (PI) line and a blank space before a hex code indicates an inactive PI line.

To obtain a hex code printout, perform the following steps.

**NOTE:** The asterisks (\*) indicate steps specific to using the coax/twinax interface menus which are only displayed when the IBM Coax/Twinax feature is installed. These steps do not apply to the Multi-Platform Interface Coax/Twinax feature.

Step	Key	Result	Notes
1. Press:			Places the printer in NOT READY mode.
2. Press:	 + 		Press both keys at the same time. Unlocking the Operator Menu allows you to test your printer.
3. Press:			First of the series of configuration menus.

Step	Key	Result	Notes
* Press:		<div style="border: 1px solid black; padding: 2px; display: inline-block;">OPERATOR MENU COAX INTERFACE</div> OR <div style="border: 1px solid black; padding: 2px; display: inline-block;">OPERATOR MENU TWINAX INTERFACE</div>	Moves forward to the COAX INTERFACE or TWINAX INTERFACE option.
4. Press:		<div style="border: 1px solid black; padding: 2px; display: inline-block;">PRINTER CONTROL INTERFACE SELECTION</div>	Moves forward to the INTERFACE SELECTION option.
*		<div style="border: 1px solid black; padding: 2px; display: inline-block;">COAX INTERFACE PRINT LANGUAGE</div> OR <div style="border: 1px solid black; padding: 2px; display: inline-block;">TWINAX INTERFACE PRINT LANGUAGE</div>	Moves forward to the PRINT LANGUAGE option.
5. Press:	 UNTIL	<div style="border: 1px solid black; padding: 2px; display: inline-block;">PRINTER CONTROL HEX PRINT MODE</div>	Moves forward to the HEX PRINT MODE option.
*		<div style="border: 1px solid black; padding: 2px; display: inline-block;">COAX INTERFACE HEX PRINT MODE</div> OR <div style="border: 1px solid black; padding: 2px; display: inline-block;">TWINAX INTERFACE HEX PRINT MODE</div>	Moves forward to the HEX PRINT MODE option.
6. Press:		<div style="border: 1px solid black; padding: 2px; display: inline-block;">HEX PRINT MODE DISABLE*</div>	Moves forward to DISABLE, the active option.
7. Press:		<div style="border: 1px solid black; padding: 2px; display: inline-block;">HEX PRINT MODE ENABLE</div>	Moves forward to ENABLE, the alternate option.
8. Press:		<div style="border: 1px solid black; padding: 2px; display: inline-block;">HEX PRINT MODE ENABLE*</div>	Asterisk (*) indicates this choice is now active.
9. Press:		<div style="border: 1px solid black; padding: 2px; display: inline-block;">NOT READY</div>	Returns the printer to Not READY mode.

Step	Key	Result	Notes
10. Press:	 + 		Press both keys at the same time to relock the Operator Menu.
			The message HEX DUMP ACTIVE flashes briefly.
11. Press:			Returns the printer to READY mode.
12.	A hex code printout results when data is sent to the printer with HEX PRINT MODE enabled. After obtaining the printout, return to normal print mode by disabling HEX PRINT MODE.		
<p><b>NOTE:</b> Printing in Hex Mode may alter prior print attributes set by the host computer. A soft reset or power-off may be required after disabling HEX PRINT MODE.</p>			

```

..... 00 01 02 03 04 05 06 07 08 09 0D 0A 0B 0C 0D 0A
..... 0E 0F 10 11 12 13 14 15 16 17 18 19 1A 1B 1C 1D
... ABCDEFGHIJKLM 1E 1F 20 41 42 43 44 45 46 47 48 49 4A 4B 4C 4D
NOPQRSTUVWXYZabc 4E 4F 50 51 52 53 54 55 56 57 58 59 5A 61 62 63
defghijklmnopqrs 64 65 66 67 68 69 6A 6B 6C 6D 6E 6F 70 71 72 73
tuvwxyz~!@#%&^* 74 75 76 77 78 79 7A 7E 21 40 23 24 25 5E 26 2A
()_+1234567890-= 28 29 5F 2B 31 32 33 34 35 36 37 38 39 30 2D 3D
[]\;/,./{}|: "<>? 5B 5D 5C 3B 27 2C 2E 2F 7B 7D 7C 3A 22 3C 3E 3F
..... 0D 0A 00 01 02 03 04 05 06 07 08 09 0D 0A 0B 0C
..... 0D 0A 0E 0F 10 11 12 13 14 15 16 17 18 19 1A 1B
... ABCDEFGHIJK 1C 1D 1E 1F 20 41 42 43 44 45 46 47 48 49 4A 4B
LMNOPQRSTUVWXYZa 4C 4D 4E 4F 50 51 52 53 54 55 56 57 58 59 5A 61
bcdefghijklmnopq 62 63 64 65 66 67 68 69 6A 6B 6C 6D 6E 6F 70 71
rstuvwxyz~!@#%&^ 72 73 74 75 76 77 78 79 7A 7E 21 40 23 24 25 5E
&*()_+1234567890 26 2A 28 29 5F 2B 31 32 33 34 35 36 37 38 39 30
-=[\;/,./{}|: "< 2D 3D 5B 5D 5C 3B 27 2C 2E 2F 7B 7D 7C 3A 22 3C
>?... 3E 3F 0D 0A

```

Figure 6-3. Sample ASCII Hex Code Printout

PRINTER CONTROL INFORMATION AREA

```

ADDR  0  1  2  3  4  5  6  7  -  8  9  A  B  C  D  E  F
  0 = 20 04 00 00 00 00 00 00 - 00 00 13 70 1D 10 1C 00
 10 = 04 06 00 50 01 00 03 64 - 00 00 00 00 00 00 00 00
 20 = 00 00 00 00 00 00 00 00 - 00 00 00 00 00 00 00 00
 30 = 00 00 00 00 00 00 00 00 - 00 00 00 00 00 00 00 00
 40 = 00 00 00 00 00 00 00 00 - 00 00 00 00 00 00 00 00
    
```

PRINTER BUFFER AREA

```

ADDR  0  1  2  3  4  5  6  7  -  8  9  A  B  C  D  E  F
 50 = 00 01 02 03 04 05 06 07 - 08 09 0A 0B 0C 0D 0E 0F
 60 = 10 11 12 13 14 15 16 17 - 18 19 1A 1B 1C 1D 1E 1F
 70 = 20 21 22 23 24 25 26 27 - 28 29 2A 2B 2C 2D 2E 2F
 80 = 30 31 32 33 34 35 36 37 - 38 39 3A 3B 3C 3D 3E 3F
 90 = 40 41 42 43 44 45 46 47 - 48 49 4A 4B 4C 4D 4E 4F
 A0 = 50 51 52 53 54 55 56 57 - 58 59 5A 5B 5C 5D 5E 5F
 B0 = 60 61 62 63 64 65 66 67 - 68 69 6A 6B 6C 6D 6E 6F
 C0 = 70 71 72 73 74 75 76 77 - 78 79 7A 7B 7C 7D 7E 7F
    
```

```

áâãäåäçñø.<(+(|
&éëèèìíîï!&*);¡
- /\AAA\Açñ!,%>?
øéèèèèííîì':#@'=""
    
```

```

ADDR  0  1  2  3  4  5  6  7  -  8  9  A  B  C  D  E  F
 D0 = 80 81 82 83 84 85 86 87 - 88 89 8A 8B 8C 8D 8E 8F
 E0 = 90 91 92 93 94 95 96 97 - 98 99 9A 9B 9C 9D 9E 9F
 F0 = A0 A1 A2 A3 A4 A5 A6 A7 - A8 A9 AA AB AC AD AE AF
100 = B0 B1 B2 B3 B4 B5 B6 B7 - B8 B9 BA BB BC BD BE BF
110 = C0 C1 C2 C3 C4 C5 C6 C7 - C8 C9 CA CB CC CD CE CF
120 = D0 D1 D2 D3 D4 D5 D6 D7 - D8 D9 DA DB DC DD DE DF
130 = E0 E1 E2 E3 E4 E5 E6 E7 - E8 E9 EA EB EC ED EE EF
140 = F0 F1 F2 F3 F4 F5 F6 F7 - F8 F9 FA FB FC FD FE FF
    
```

```

0abcdefghijklmnopqršđž±
°jklmnopqrđžæ,řš
μ~stuvwxyzizĐŸP@
^£¥•@§¶%&¾[]""'×
(ABCDEFGHI-888888
}JKLMNOPQR!00000\
÷STUVWXYZ*888880
1234567890 0000
    
```

Figure 6-4. Sample Coax Hex Code Printout

```

0      1      1      1      2      1      3      1      4
00000000000000001111111111111111222222222222222233333333333333334
0123456789ABCDEF0123456789ABCDEF0123456789ABCDEF0123456789ABCDF0
    
```

```

0      1      1      1      2      1      3      1
4444444444444444555555555555555566666666666666667777777777777777B
123456789ABCDEF0123456789ABCDEF0123456789ABCDEF0123456789ABCDEF0
 áâãäåäçñø.<(+(|&éëèèìíîï!&*);¡- /\AAA\Açñ!,%>?øéèèèèííîì':#@'=""
    
```

```

0      1      1      1      2      1      3      1
88888888888888889999999999999999AAAAAAAAAAAAAAAAAAAAAAAABBBBBBBBBBBBBBBC
123456789ABCDEF0123456789ABCDEF0123456789ABCDEF0123456789ABCDEF0
 abcdefghi«»đž±° jklmnopqrđžæ,řšμ~stuvwxyzizĐŸP@^£¥•@§¶%&¾[]""'×(
    
```

```

0      1      1      1      2      1      3      1
CCCCCCCCCCCCCCCCDDDDDDDDDDDDDDDEEEEEEEEEEEEEEEEEEEEEFFFFFFFFFFF
123456789ABCDEF0123456789ABCDEF0123456789ABCDEF0123456789ABCDEF
ABCDEFGHI-888888}JKLMNOPQR!00000\÷STUVWXYZ*8888801234567890 0000
    
```

Figure 6-5. Sample Twinax Hex Code Printout

## Fault Messages

---

If a fault condition occurs in the printer, the Attention indicator on the operator panel lights, and the first line of the operator panel message display indicates the fault. The second line of the display indicates how to clear the fault.

Table 6–1 explains each fault message and describes how to correct the fault condition. Displayed faults fall into one of two categories:

- Operator correctable.
- IBM service representative required to correct.

### Fault Correction Procedure

Before correcting a fault, read the fault explanation, then proceed to fix the problem, taking the following steps:

1. Press any key except **Form Feed** to silence the alarm if necessary.
2. Write down the number of the error message(s) being displayed.
3. Read the fault explanation, then proceed to fix the problem, if possible.
4. Press **Stop** to clear the fault message. Press **Start** to return to Ready mode, and resume printing.
5. If the fault message reappears, power off the printer, wait 15 seconds, then power on the printer.
6. Run your print job again. If the fault message reappears, turn off power to the printer, then call your IBM service representative. Otherwise, no further attention is required.

The following table explains each fault message and offers suggestions for correcting the fault condition.

**Table 6–1. Fault Messages**

<b>Fault Message</b>	<b>Operator Correctable?</b>	<b>Explanation</b>	<b>Solution</b>
001 END OF FORMS LOAD FORMS	Yes	Printer is out of paper.	Load paper according to instructions on page 2–35.
002 FORMS JAMMED CLEAR JAM AND RELOAD FORMS	Yes	No paper motion.	Clear paper jam and reload paper. See the <i>Operator's Guide</i> . Reset forms thickness lever.
003 FORMS EJECTED PRESS EJECT/RESTORE	Yes	Non–error status message.	Press <b>Eject/Restore</b> key to return paper to print position.
004 VIEW FORMS PRESS VIEW KEY	Yes	Non–error status message.	Press <b>View</b> key to return paper to print position.
006 HOST SYSTEM REQUEST ATTENTION	Yes	Host attention message.	The host computer or printer controller requires attention.
007 FM HEADER ERROR	No	Format header error. Applications software has violated format header parameters.	Contact your system administrator.
008 HOLD PRINT TIMEOUT PRESS START	Yes	Printer was off–line more than 10 minutes and the “Intervention Required” parameter is set to “Send to Host.”	Press <b>Start</b> to put printer in READY state.
009 INVALID KEY PRESS	Yes	Appears briefly if an inactive key is pressed in current print mode.	Re–enter the value, or press the correct key.
010 PARAMETER ERROR	No	Illegal parameter value received in command code.	Contact your system administrator.
011 SCS COMMAND ERROR	No	Printer received undefined control character.	Contact your system administrator.
012 STRUCTURED FIELD ERROR	No	Applications software has violated structured data field parameters.	Contact your system administrator.
013 ACTIVATE LOST	No	Printer detects twinax protocol communication errors.	The printer reports the error.

Fault Message	Operator Correctable?	Explanation	Solution
014 INVALID ACTIVATE	No	Printer detects twinax protocol communication errors.	The printer reports the error.
015 COMMUNICATION CHECK CHECK CABLE	Yes	Line not active. (Twinax interface)	Check cable connection.
016 INVALID COMMAND	No	Printer detects twinax protocol communication errors.	The printer reports the error; host action is required.
021 RECEIVE BUFFER OVERRUN VERIFY CONFIGURATION	Yes	Receive overrun. (Serial interface)	Check printer serial port configuration setup. Ensure that baud rate matches both host and printer settings.
022 UNIT ADDRESS NOT RECEIVED CHECK PRINTER ADDRESS	Yes	Unit address not recognized by printer. (Poll timeout, twinax interface)	Ensure that printer address matches host setting.
024 SERIAL LINE PARITY ERROR VERIFY CONFIGURATION	Yes	Parity error. (Serial interface)	Check printer serial port configuration setup. Ensure that parity setting matches both host and printer settings.
025 SERIAL FRAMING ERROR VERIFY CONFIGURATION	Yes	Framing error. (Serial interface)	Check printer serial port configuration setup. Ensure that it matches host setting.
026 HEX DUMP MODE	N/A	Printer attach status message.	No action necessary.
027 COMMUNICATIONS CHECK CALL SYSTEM OPERATOR	Yes	Enable poll timeout. The printer was not enabled for one minute. (Coax interface)	Check cable connection and host system.
028 COMMUNICATIONS CHECK CALL SYSTEM OPERATOR	Yes	Poll timeout error. The printer was not polled for one minute. (Coax interface)	Check cable connection and host system.
029 8344 DIAGNOSTIC TEST FAILED	No	Link-level code test detects hardware failure.	Contact your IBM service representative.
031 END OF FORMS TIMEOUT LOAD FORMS	Yes	A timeout message is sent to the host if paper is not loaded 10 minutes after <b>Stop</b> was pressed to clear the paper out fault.	Load paper. See <i>Operator's Guide</i> for procedure.



Fault Message	Operator Correctable?	Explanation	Solution
032 FORMS JAMMED TIMEOUT CLEAR JAM AND RELOAD FORMS	Yes	A timeout message is sent to the host if no paper motion has occurred for 10 minutes after <b>Stop</b> was pressed to clear the jam fault.	Clear paper jam and reload paper. See <i>Operator's Guide</i> for procedure.
041 BUFFER OVERFLOW	Yes	Host sends data after the printer buffer is full. (Serial interface.)	Check printer serial port configuration setup. Ensure that the Data Terminal Ready setting matches both host and printer settings.
042 CUSTOM SET DOES NOT EXIST SAVE FIRST	Yes	This custom configuration set does not exist.	Save the custom set. Refer to page 3–20, “Saving Your Configuration in a Custom Set.”
043 CUSTOM SET ALREADY EXISTS DELETE EXISTING SET FIRST	Yes	Custom set is write-protected.	Delete existing set, then save new set. Refer to page 4–18 “Delete Custom Set.”
044 EC FIRMWARE/HARDWARE ERROR	No	Fatal firmware error on the controller board.	Contact your IBM service representative.
046 EC STOPPED AT STATE <state>	No	Controller self-test and initialization sequence was halted at <state>, where <state> is one of 10 numerically coded messages.	Contact your IBM service representative.
056 HAMMER COIL OPEN	No	Electrical malfunction of one or more hammer coils.	(You can continue to print with degraded print quality.) Contact your IBM service representative.
057 CLOSE PLATEN	Yes	Forms thickness lever is raised to the open position.	Lower the forms thickness lever.
058 SHUTTLE JAM SEE USER'S GUIDE	No	No shuttle movement or the shuttle is moving at the wrong speed.	Make sure the ribbon is not twisted and the forms thickness lever is set correctly. If the fault reoccurs, contact your IBM service representative.
059 CANCEL PRINT ACTIVE	N/A	Non-error status message.	No action necessary.
060 PRINTER HOT	No	Controller board sensors report high temperatures on the board.	Contact your IBM service representative.

Fault Message	Operator Correctable?	Explanation	Solution
062 EXHAUST FAN FAULT	Yes	Sensors cannot detect current in fan circuit.	<p>Power off the printer and remove paper guide assembly (for instructions, refer to your <i>6400 Maintenance Information Manual</i>). Check that the fan cable is connected. Check for obstruction of vents and fan airway; remove any obstructions. Check for items beneath the printer blocking cabinet vents. Power back on the printer. If this message reoccurs, contact your IBM service representative.</p> <p><b>NOTE:</b> This message should not appear on a Pedestal model. If this message does appear, contact your IBM Service Representative.</p>
063 INTAKE FAN FAULT	Yes	Sensors cannot detect current in fan circuit.	<p>Power off the printer and remove paper guide assembly (for instructions, refer to your <i>6400 Maintenance Information Manual</i>). Check that the fan cable is connected. Check for obstruction of vents and fan airway; remove any obstructions. Check for items beneath the printer blocking cabinet vents. Power back on the printer. If this message reoccurs, contact your IBM service representative.</p>
065 HAMMER BANK FAN FAULT	Yes	Sensors cannot detect current in fan circuit.	<p>Power off the printer and remove paper guide assembly (for instructions, refer to your <i>6400 Maintenance Information Manual</i>). Check that the fan cable is connected. Check for obstruction of vents and fan airway; remove any obstructions. Check for items beneath the printer blocking cabinet vents. Power back on the printer. If this message reoccurs, contact your IBM service representative.</p>

<b>Fault Message</b>	<b>Operator Correctable?</b>	<b>Explanation</b>	<b>Solution</b>
069 DATA CLEARED	N/A	Appears when data is cleared out of printer after <b>Cancel</b> key has been pressed.	No action necessary.
080 POWER SUPPLY HOT	No	Circuits are overheating on the power supply board.	Contact your IBM service representative.
082 POWER SUPPLY 8.5V FAILED	No	Internal power failure.	Contact your IBM service representative.
084 POWER SUPPLY 48V FAILED	No	Internal power failure.	Contact your IBM service representative.
085 CONTROLLER VOLTAGE	No	Controller voltage failure.	Contact your IBM service representative.
086 CONTROLLER 15V	No	Controller voltage failure.	Contact your IBM service representative.
087 PLATEN OPEN TIMEOUT CLOSE PLATEN	Yes	Forms thickness lever has been open for at least one minute.	Close forms thickness lever.
088 CONTROLLER 23.5V	No	Controller voltage failure.	Contact your IBM service representative.
089 RIBBON STALL	Yes	No ribbon movement.	Make sure the ribbon is not twisted and the forms thickness lever is set to match thickness of media being used. If fault reoccurs, contact your IBM service representative.
090 SHUTTLE COVER OPEN CLOSE SHUTTLE COVER	No	Shuttle cover is missing, damaged, or not correctly installed.	Contact your IBM service representative.
092 RIBBON DRIVER CIRCUIT	No	Controller board does not detect ribbon drive motor.	Contact your IBM service representative.
101 UPPER DRIVER SHORT	No	Hammer driver circuits on the controller board shorted to ground.	Contact your IBM service representative.
102 LOWER DRIVER SHORT	No	Circuit(s) on the hammer bank or in the hammer bank power cable shorted to ground.	Contact your IBM service representative.

<b>Fault Message</b>	<b>Operator Correct-able?</b>	<b>Explanation</b>	<b>Solution</b>
107 HAMMER COIL HOT	No	One or more hammer coils are overheating.	Stop printing and allow the printer to cool for five minutes. If the fault reoccurs, contact your IBM service representative.
110 STACK OVERFLOW SEE USER'S GUIDE	No	Fatal firmware error on the controller board.	Contact your IBM service representative.
111 STACK UNDERFLOW SEE USER'S GUIDE	No	Fatal firmware error on the controller board.	Contact your IBM service representative.
112 UNDEFINED OPCODE SEE USER'S GUIDE	No	Fatal firmware error on the controller board.	Contact your IBM service representative.
113 PROTECTED INSTRUCTION SEE USER'S GUIDE	No	Fatal firmware error on the controller board.	Contact your IBM service representative.
114 ILLEGAL OPERAND ACCESS SEE USER'S GUIDE	No	Fatal firmware error on the controller board.	Contact your IBM service representative.
115 ILLEGAL INSTRUCTION ACCESS SEE USER'S GUIDE	No	Fatal firmware error on the controller board.	Contact your IBM service representative.
116 ILLEGAL EXTERNAL BUS ACCESS SEE USER'S GUIDE	No	Fatal firmware error on the controller board.	Contact your IBM service representative.
117 A TO D OVERRUN SEE USER'S GUIDE	No	Fatal firmware error on the controller board.	Contact your IBM service representative.
118 UNDEFINED INTERRUPT SEE USER'S GUIDE	No	Fatal firmware error on the controller board.	Contact your IBM service representative.
119 TCB CORRUPTED SEE USER'S GUIDE	No	Fatal firmware error on the controller board.	Contact your IBM service representative.
120 ACCESS NULL POINTER SEE USER'S GUIDE	No	Fatal firmware error on the controller board.	Contact your IBM service representative.
121 PAPER NOT AT SPEED SEE USER'S GUIDE	No	Fatal firmware error on the controller board.	Contact your IBM service representative.

<b>Fault Message</b>	<b>Operator Correctable?</b>	<b>Explanation</b>	<b>Solution</b>
122 PAPER NOT SCHEDULED SEE USER'S GUIDE	No	Fatal firmware error on the controller board.	Contact your IBM service representative.
123 PAPER BUSY TOO LONG SEE USER'S GUIDE	No	Fatal firmware error on the controller board.	Contact your IBM service representative.
124 PAPER FIFO OVERFLOW SEE USER'S GUIDE	No	Fatal firmware error on the controller board.	Contact your IBM service representative.
125 PAPER FIFO UNDERFLOW SEE USER'S GUIDE	No	Fatal firmware error on the controller board.	Contact your IBM service representative.
126 PAPER FEED BAD TABLE SEE USER'S GUIDE	No	Fatal firmware error on the controller board.	Contact your IBM service representative.
127 PAPER FEED ILLEGAL STATE SEE USER'S GUIDE	No	Fatal firmware error on the controller board.	Contact your IBM service representative.
128 PAPER FEED INVALID COMMAND SEE USER'S GUIDE	No	Fatal firmware error on the controller board.	Contact your IBM service representative.
129 PAPER FEED INVALID PARAMETER SEE USER'S GUIDE	No	Fatal firmware error on the controller board.	Contact your IBM service representative.
130 PAPER FEED PARTLY ENERGIZED SEE USER'S GUIDE	No	Fatal firmware error on the controller board.	Contact your IBM service representative.
131 PAPER FEED INTERRUPT SEE USER'S GUIDE	No	Fatal firmware error on the controller board.	Contact your IBM service representative.
132 RIBBON INVALID COMMAND SEE USER'S GUIDE	No	Fatal firmware error on the controller board.	Contact your IBM service representative.
133 RIBBON INVALID STATE SEE USER'S GUIDE	No	Fatal firmware error on the controller board.	Contact your IBM service representative.
134 PLATEN INVALID COMMAND SEE USER'S GUIDE	No	Fatal firmware error on the controller board.	Contact your IBM service representative.

<b>Fault Message</b>	<b>Operator Correctable?</b>	<b>Explanation</b>	<b>Solution</b>
135 PLATEN INVALID STATE SEE USER'S GUIDE	No	Fatal firmware error on the controller board.	Contact your IBM service representative.
136 PLATEN INVALID PARAMETER SEE USER'S GUIDE	No	Fatal firmware error on the controller board.	Contact your IBM service representative.
137 SHUTTLE INVALID COMMAND SEE USER'S GUIDE	No	Fatal firmware error on the controller board.	Contact your IBM service representative.
138 SHUTTLE INVALID PARAMETER SEE USER'S GUIDE	No	Fatal firmware error on the controller board.	Contact your IBM service representative.
139 SHUTTLE OVERSPEED SEE USER'S GUIDE	No	Fatal firmware error on the controller board.	Contact your IBM service representative.
990 MACHINE CHECK	N/A	Host status message.	No action necessary.
NON-VOLATILE MEMORY FAILED	No	Non-volatile memory fault.	Contact your IBM service representative. NOTE: You can still print, but you cannot save configuration changes as the NVRAM is defective.
A97 GRAPHIC CHECK ERROR PRESS STOP THEN START	Yes	Printer has received a non-printable character.	Press <b>Stop</b> then <b>Start</b> .
ENERGY SAVER MODE ACTIVE	N/A	Status message: printer is in low-energy idle state, all fans and higher voltages are off, only +5Vdc logic circuits are active.	No action necessary.
HAMMER COIL BAD #, #, #	No	Malfunction of one or more hammer coils.	(You can continue to print with degraded print quality.) Contact your IBM service representative.
NOT READY	N/A	Printer state message: printer is offline, not in communication with host.	No action necessary.
OPERATOR MENU <first menu item>	N/A	Non-error status message.	No action necessary.
OPERATOR MENU LOCKED	N/A	Non-error status message.	No action necessary.
OPERATOR MENU UNLOCKED	N/A	Non-error status message.	No action necessary.

<b>Fault Message</b>	<b>Operator Correctable?</b>	<b>Explanation</b>	<b>Solution</b>
PA1 SELECTED	N/A	Attach status message.	No action necessary.
PA2 SELECTED	N/A	Attach status message.	No action necessary.
P05 DIAGNOSTIC TEST PASSED	N/A	Non-error status message.	No action necessary.
P17 SECURITY VIOLATION	No	Security code of PAL on controller board does not match code of firmware on the controller board.	Contact your IBM service representative.
PLEASE WAIT.. RESET IN PROGRESS	N/A	Printer reset in progress.	No action necessary.
READY	N/A	Printer state message: printer is online and in communication with host.	No action necessary.
RIBBON INK OUT CHANGE RIBBON	Yes	RibbonMinder has determined that the ribbon is out of ink.	Replace the ribbon and verify ribbon life is reset to 100%.
SERVICE MENU <first service test>	N/A	Non-error status message.	No action necessary.
TESTING HARDWARE PLEASE WAIT	N/A	Status message when printer runs self-tests and initialization routines.	No action necessary.
TOP OF FORM SET	N/A	Non-error status message.	No action necessary.





# 7

## RibbonMinder™

### Chapter Contents

---

Overview .....	7-2
Configuring the RibbonMinder .....	7-3
Running a Job .....	7-5
New Ribbon .....	7-5
Ribbon Action .....	7-5
Ribbon Size .....	7-6
Ribbon Adjust .....	7-6
Fault Action .....	7-7

## Overview

---

RibbonMinder™ is a user-definable software feature that determines when a ribbon should be changed. It does this by monitoring ink consumption and alerts you when the print quality may fall below a level that you designate. This is especially important if you are printing bar codes to be scanned. This chapter explains how RibbonMinder works and how to configure it to meet your specific print job requirements.

Like the fuel gauge in your car, RibbonMinder indicates how much usable ink remains in the ribbon. The “gauge” for RibbonMinder is the message display on the control panel. The following message is typical for a new ribbon (100% full):

READY 100%
------------

As printing continues, the percentage of usable ink in the ribbon decreases (percentage ranges from 100% to -99%):

READY 74%
-----------

Ribbon ink being consumed

READY 8%
----------

Ribbon life approaching end

When 0% usable ink appears, the printer is typically configured to stop printing and display the following message:

RIBBON OUT OF INK CHANGE RIBBON
------------------------------------

Continue with the next sections for configuring RibbonMinder options.

## Configuring the RibbonMinder

This section explains how to unlock the PROGRAM MODE, find the RibbonMinder options, make changes, exit the configuration menu, and lock the PROGRAM MODE.

Following this section is a procedure for changing the Ribbon Size option of RibbonMinder.

**NOTE:** All RibbonMinder options are automatically saved in NVRAM when selected.

As you perform the following steps, refer to the RibbonMinder menu diagram shown in Figure 7-1.

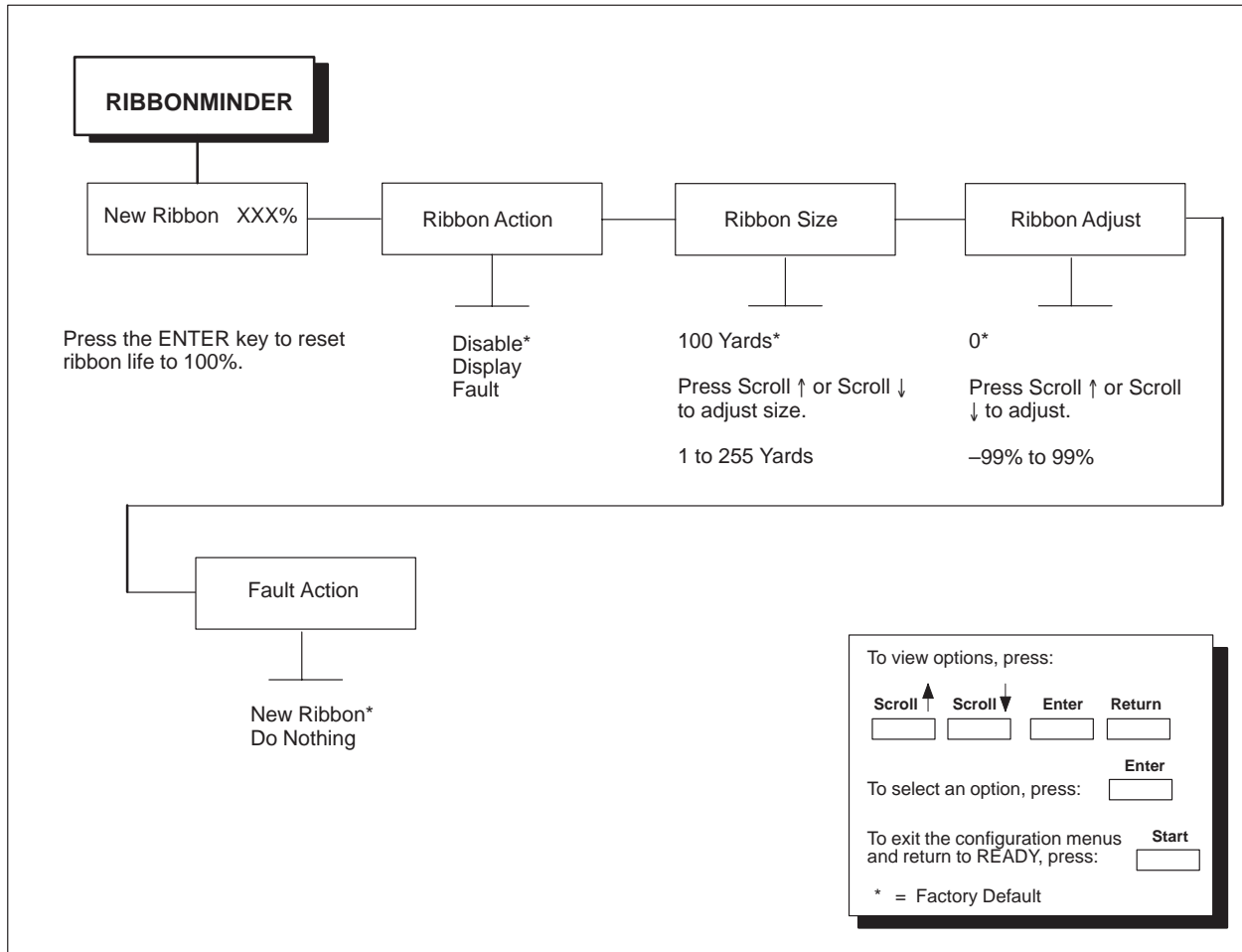



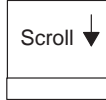



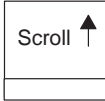
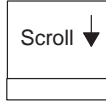



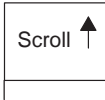

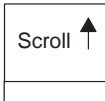
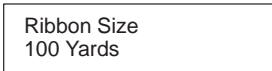

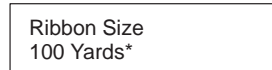
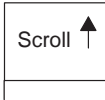
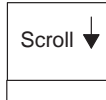





Figure 7-1. RibbonMinder Menu Diagram

Step	Key	Result	Notes
1. Press:			Places the printer in NOT READY mode.
2. Press:	 + 		Press both keys at the same time. Unlocking the Operator Menu allows you to test your printer.
3.			
4.	 or 		
5.			
6.			Scroll through to find Ribbon Adjust, Ribbon Size, Ribbon Adjust
7.			Allows you to adjust desired option.
8. Press			Selects option value.
9.	 or 		Exits the menu.
10.			Returns the printer to the READY mode.
11.	Close the printer cover. You can resume printing.		

## Running a Job

---

Once you have set up options for RibbonMinder, it works without attention. When you begin printing with RibbonMinder enabled and Ribbon Action set to DISPLAY, the message display shows a ribbon life value of 100%. The ribbon life decreases as the ink is consumed.

## New Ribbon

---

The New Ribbon option provides information concerning the percentage of ribbon used and allows you to reset the ribbon life when you replace a worn ribbon. To reset the ribbon life from the operator panel, press **Enter** while this option is displayed. It may be necessary to replace ribbons *before* the ink has been depleted (e.g. when the ribbon has been snagged, folded, or otherwise damaged).

## Ribbon Action

---

A fault message displays when the ink consumption reaches 0%. The Ribbon Action option allows you to perform any of the three following functions:

- **DISABLE** does not display the RibbonMinder ink consumption percentage. The percentage is calculated but not displayed.
- **DISPLAY** allows you to view the RibbonMinder ink consumption display. A fault message displays when the ink consumption reaches 0%.
- **FAULT** displays an error message, which is Ribbon Ink Out, Change Ribbon, when the RibbonMinder consumption percentage falls below zero. The error message can be cleared and printing can continue for approximately another two minutes.

After the two-minute period has elapsed, the fault will reoccur if the Ribbon Action remains set on FAULT. If the Ribbon Action is changed to DISABLE or DISPLAY within the two-minute period, the fault will not reoccur.

If you do not want to change the ribbon at this time, you may disable RibbonMinder. If the ribbon is worn, the “Change Ribbon” message will reappear once the function is enabled again until the ribbon is changed. If a fault message is displayed on the control panel and the Ribbon Fault is set to New Ribbon, the ribbon percentage automatically resets back to 100% when the ribbon is changed.

If the message display indicates the need to install a new ribbon and your print job is one page short of completion, press **Stop** and then **Ready** to clear the fault and print the last page. Otherwise, you may continue your print job at the end of this procedure. The fault will occur again two minutes after clearing the fault.

## Ribbon Size

---

RIBBON SIZE specifies the length of the ribbon installed. When installing or replacing a ribbon, you can adjust the ribbon size by using the Ribbon Size option.

The default ribbon size is 100 yards. The size can be adjusted from 1 to 255 yards.

Pressing the Scroll ↑ key increases the ribbon size, while pressing the Scroll ↓ key decreases the ribbon size.

## Ribbon Adjust

---

RIBBON ADJUST allows the printing of more or less pages before the display reaches 0%.

The adjustment is a percentage of the default (0%) and ranges from -99% to 99%. For example, if the printer ordinarily printed 1000 pages at the default setting (0%), by setting the adjustment to 10% it would print 1100 pages (1000 + 10%) before the display reached 0%. Likewise, if the adjustment was set to -20%, it would print 800 pages (1000 - 20%) before the display reached 0%.

Pressing the Scroll ↑ key increases the percentage, while pressing the Scroll ↓ key decreases the percentage.

## Fault Action

---

FAULT ACTION selects the way the fault message will be reset.

- New Ribbon, the default, the Ribbon Out of Ink, Change Ribbon fault will be reset when the platen is opened. Opening the platen will also reset the ribbon life to 100%.
- Do Nothing, the ribbon life may only be reset using the new ribbon menu option.





# A Printer Specifications

## Contents

---

Ribbon Specifications .....	A-2
Paper Specifications .....	A-3
Paper .....	A-3
Labels .....	A-3
Printer Dimensions and Weight .....	A-4
Cabinet Models .....	A-4
Pedestal Models .....	A-4
Environmental Characteristics .....	A-5
Temperature .....	A-5
Relative Humidity .....	A-5
Acoustic Noise Level .....	A-5
Electrical Characteristics .....	A-6
Input Voltage .....	A-6
Power Consumption .....	A-6
Interfaces .....	A-8
Cables .....	A-9

## Ribbon Specifications

---

**NOTE:** The ribbon life figures listed below are based on IBM tests conducted in accordance with ANSI Standard X3A.182. Actual ribbon life may vary depending upon the user's quality criteria, printer condition, machine settings, paper quality, and bar code requirements. Label yield depends on label format, bar code symbology, and other parameters. Label yield with high-performance scanning equipment may exceed these yields. Use only the ribbons listed below.

**IBM General Purpose Ribbon (60 yd.)** P/N 1040990

Used for general text printing such as data and word processing.  
Average yield: 20 million DP characters

**IBM General Purpose Ribbon (100 yd.)** P/N 1040995

Average yield: 30 million DP characters

**IBM High Contrast Ribbon (60 yd.)** P/N 1040993

Used for general text printing as well as OCR, graphics and bar code printing.  
Average yield: 20 million DP characters, 2500 AIAG-B3 labels with visible light source scanning equipment, or 1300 AIAG-B3 labels with infrared light source scanning equipment.

**IBM High Contrast Ribbon (100 yd.)** P/N 1040998

Average yield: 30 million DP characters, 3600 AIAG-B3 labels with visible light source scanning equipment, or 1800 AIAG-B3 labels with infrared light source scanning equipment.

### Ordering Ribbons (U.S. Only)

Ribbons may be purchased from Lexmark Authorized IBM Supplies Dealers or directly from Lexmark by calling: **1-800-438-2468**.

Fax orders may be sent to: **1-800-522-3422**

Mail orders may be sent to: Lexmark International, Inc., 1221 Alverser Drive, Midlothian, VA 23113.

### Ordering Ribbons (Outside of U.S.)

Order supplies by contacting your local Lexmark International distributor or by writing to Lexmark International, Inc.

Lexmark International, Inc.

P.O. Box 11427

Lexington, KY, 40575-1427 USA

# Paper Specifications

---

**NOTE:** The following paper specifications are general guidelines. Paper stock should be tested with applications to determine print quality.

## Paper

Type:	Edge-perforated, fan-fold, 3 to 17 inches (7.62 to 43.18 cm) wide*, 2 to 24 inches (5.08 to 60.96 cm) long** <ul style="list-style-type: none"><li>• Single-part: 15 pound (57 g/m<sup>2</sup>) to 100 pound (377 g/m<sup>2</sup>) stock.</li><li>• Multi-part carbon: 1- to 6-part forms, maximum 12 pound (45 g/m<sup>2</sup>) ply of upper plies.</li><li>• Multi-part carbonless, maximum of 6-part forms. Test readability of greater than 4-part forms.</li></ul>
Form Thickness:	0.025 inches (0.064 cm) maximum
Drive:	Adjustable tractors (6-pin engagement)

\*On pedestal models, when using the rear paper exit, the maximum form width is 16 inches (40.64 cm).

\*\*On cabinet models, forms longer than 12 inches can be used by opening the front and rear printer doors.

## Labels

On Backing:	One-part continuous perforated fan-fold back form. Labels must be placed at least 1/6 inch (0.42 cm) from the fan-fold perforation. Backing adhesive must not be squeezed out during printing.
Sheet Size:	3 to 17 inches (7.62 to 43.18 cm) wide*, including the two standard perforated tractor feed strips. A maximum sheet length of 16 inches (40.64 cm) between top and bottom perforations.**
Thickness	Not to exceed 0.025-inch (0.064 cm), including backing sheet.

\*On pedestal models, when using the rear paper exit, the maximum form width is 16 inches (40.64 cm).

\*\*On cabinet models, forms longer than 12 inches can be used by opening the front and rear printer doors.

## Printer Dimensions and Weight

---

### Cabinet Models

Height:	42.5 inches (108 cm)
Width:	27 inches (68.6 cm)
Depth:	29 inches (73.7 cm)
Weight:	225 lbs. (102.1 kg) unpackaged 285 lbs. (129.3 kg) packaged

### Pedestal Models

Height:	35.5 inches (90.2 cm)
Width:	24.6 inches (62.5 cm)
Depth:	30 inches (76.2 cm)
Weight:	120 pounds. (54.4 kg) unpackaged 160 pounds. (72.6 kg) packaged

# Environmental Characteristics

---

## Temperature

Operating: 50° to 104° F (10° to 40°C)

Storage: -40° to 158° F (-40° to 70°C)

## Relative Humidity

Operating: 10% to 90% (noncondensing)

Storage: 5% to 95% (noncondensing)

## Acoustic Noise Level

	Cabinet Models	Pedestal Models	
Acoustic Noise Levels per ISO 9296		04P	08P
Printing	52 dB	60 dB	63 dB
	6.8 Bel	7.7 Bel	8.1 Bel
Standby	46 dB	46 dB	46 dB
	6.3 Bel	6.3 Bel	6.3 Bel
Geraeuschemission nach ISO 9296			
Druckend	52 dB	60 dB	63 dB
	6.8 Bel	7.7 Bel	8.1 Bel
Betriebsbereit	46 dB	46 dB	46 dB
	6.3 Bel	6.3 Bel	6.3 Bel
<p><b>NOTE:</b> Cabinet model noise levels listed are with the cabinet doors closed. Levels will be higher if the doors are open.</p> <p>Pedestal model noise levels listed are for rear paper exit. Levels will be higher for top paper exit.</p>			

## Electrical Characteristics

---

### Input Voltage

Line Voltage Design Range	Line Frequency	RMS Current		
		475 LPM	800 LPM	1200 LPM
88–135 V RMS	47–63 Hz	6A @ 100 V	6A @ 100 V	6A @ 100 V
176–270 V RMS	47–63 Hz	3A @ 200 V	3A @ 200 V	3A @ 200 V

### Power Consumption

6400–004

6400–04P

120 VAC 60 Hz	Operating DP Mode		Standby	
	All H's	Max Typical	Not Energy Star	Energy Star
Watts	200	165	70	25
BTU/Hour	680	560	240	85
VA	350	290	130	48

220 VAC 50 Hz	Operating DP Mode		Standby	
	All H's	Max Typical	Not Energy Star	Energy Star
Watts	180	150	60	25
BTU/Hour	615	510	205	85
VA	390	310	145	55

6400-008

6400-08P

120 VAC 60 Hz	Operating DP Mode		Standby	
	All H's	Max Typical	Not Energy Star	Energy Star
Watts	240	190	70	25
BTU/Hour	820	650	240	85
VA	415	330	130	48

220 VAC 50 Hz	Operating DP Mode		Standby	
	All H's	Max Typical	Not Energy Star	Energy Star
Watts	210	180	60	25
BTU/Hour	720	615	205	85
VA	435	360	145	55

6400-012

120 VAC 60 Hz	Operating DP Mode		Standby	
	All H's	Max Typical	Not Energy Star	Energy Star
Watts	290	215	70	25
BTU/Hour	990	735	240	85
VA	490	370	130	48

220 VAC 50 Hz	Operating DP Mode		Standby	
	All H's	Max Typical	Not Energy Star	Energy Star
Watts	280	200	60	25
BTU/Hour	960	615	205	85
VA	550	410	145	55

## Interfaces

---

Type:	Three resident parallel, two resident serial, two optional coax, two optional twinax
Logic Levels:	TTL/EIA-232-E, EIA-422-A
Data Format:	ASCII
Compatibility:	EIA-232-E, EIA-422-A, PC Parallel, Dataproducts, IEEE 1284, Twinax, Coax
Transfer Rates:	Up to 200K bytes/sec on parallel interfaces Up to 115,200 baud on serial interfaces
Buffer:	16 kilobytes on serial interfaces 16 kilobytes on parallel interfaces



## Cables

---

A power line cord is provided with the printer, but no data cables. The following provides data cable requirements and ordering information.

**ASCII Serial/Parallel:** The 6400 printer is connected to personal computers and controllers via industry standard EIA-232-E and PC-parallel printer cables. For Dataproducts interfaces, you will need to obtain a Dataproducts cable. Contact your IBM service representative to order the following:

- EIA-232-E Cable
- PC-Parallel Cable
- Dataproducts Adapter Feature

**AS/400:** The 6400 is connected to the AS/400 ASCII Workstation Controller via the following IBM cables, available through your IBM service representative:

- 20 ft. RS-232
- 40 ft. RS-232

**RISC System/6000:** For RS-232 attachment to the IBM RISC System/6000, the following are required:

- IBM Async cable EIA-232/V.24
- Printer/terminal interposer EIA-232
- Serial Cable Kit (PN 12H1204)

**Coax/Twinax Interface Feature:** Contact your IBM service representative for attachment requirements.

# Printing Rates

The printing speed of text is measured in lines per minute (lpm), and is a function of the selected font and the vertical dot density. Printing speed is independent of the number of characters configured in the character set repertoire. Print rates for lines containing attributes such as bold or emphasized printing, superscripts, subscripts, or elongated attributes will decrease to not less than half the rates of the font without such attributes. The exact print rate of lines containing these attributes depends on the specific print job, but software maximizes the throughput by dynamically determining which dot rows contain adjacent dots and must be printed in two strokes. The table below lists typical printing rates.

The reverse paper feed capability allows the printing of multiple densities on a single line. This is useful in printing forms and text together or in mixing different fonts on a print line. Use of multiple densities and reverse paper feed also affects throughput. (Due to paper path restrictions, pedestal models have only limited reverse paper capability.)

## 6400 Nominal Print Rates

PRINT QUALITY DOT DENSITY (DPI)	CHARACTERS PER INCH	DOT MATRIX	PERFORMANCE								
			UPPERCASE ONLY LPM			DESCENDERS & UNDERLINE LPM			PLOT MODE IPM		
			-004 -04P	-008 -08P	-012	-004 -04P	-008 -08P	-012	-004 -04P	-008 -08P	-012
NOTE 1		NOTE 2									
CORRESPONDENCE 90 (180) X 96	10 12 15	7 (13) X 9 + 3 6 (11) X 9 + 3 (9) x 9 + 3	190	320	480	147	246	370	19.8	33.3	50
DATA PROCESSING 60 (120) X 72	10 12 13.3 15 17.1	5 (9) X 7 + 2 4 (7) X 7 + 2 4 (7) X 7 + 2 3 (5) X 7 + 2 3 (5) X 7 + 2	356	600	900	285	480	720	39.6	67.7	100
HIGH SPEED 60 (120) X 48	10 12 13.3	5 (9) X 5 + 1 4 (7) X 5 + 1 4 (7) X 5 + 1	475	800	1200	407	712	1026	59.3	100	150

NOTE 1 A (B) X C, where:

A is maximum horizontal dot density  
B is horizontal dot placement density  
C is vertical dot density

NOTE 2 D (E) X F + G, where:

D is maximum number of dots that may be placed on  
E horizontal dot positions  
F is number of vertical dots for uppercase symbols  
G is number of dots available for descenders

# **B** A Quick Look at Line Matrix Printing

## **Contents**

---

Character Formation .....	B-2
Printing Speed .....	B-4

## Character Formation

---

The IBM 6400 is an impact printer: it creates characters by printing ink dots on paper. Dots overlap to produce a solid-appearing character of uniform density. The dots are made by an assembly of steel hammers mounted on a rapidly oscillating shuttle. The hammers strike the paper through a moving ink ribbon. The dot patterns of characters are mapped in printer memory on invisible matrices, as shown in Figure B-1.

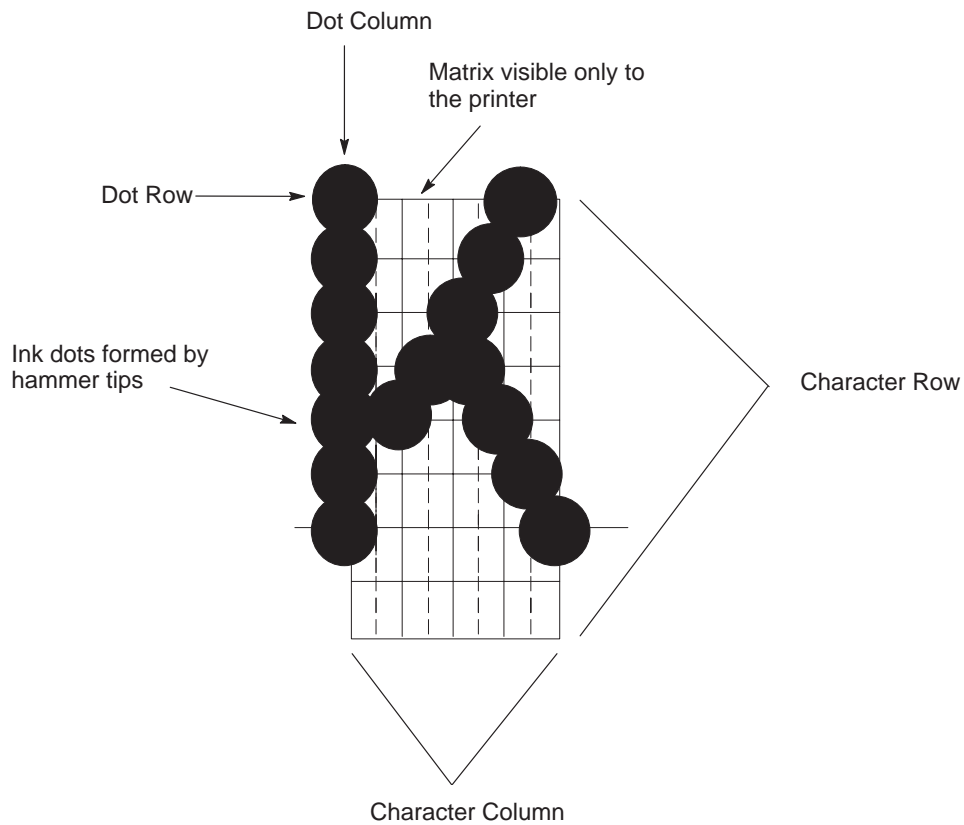
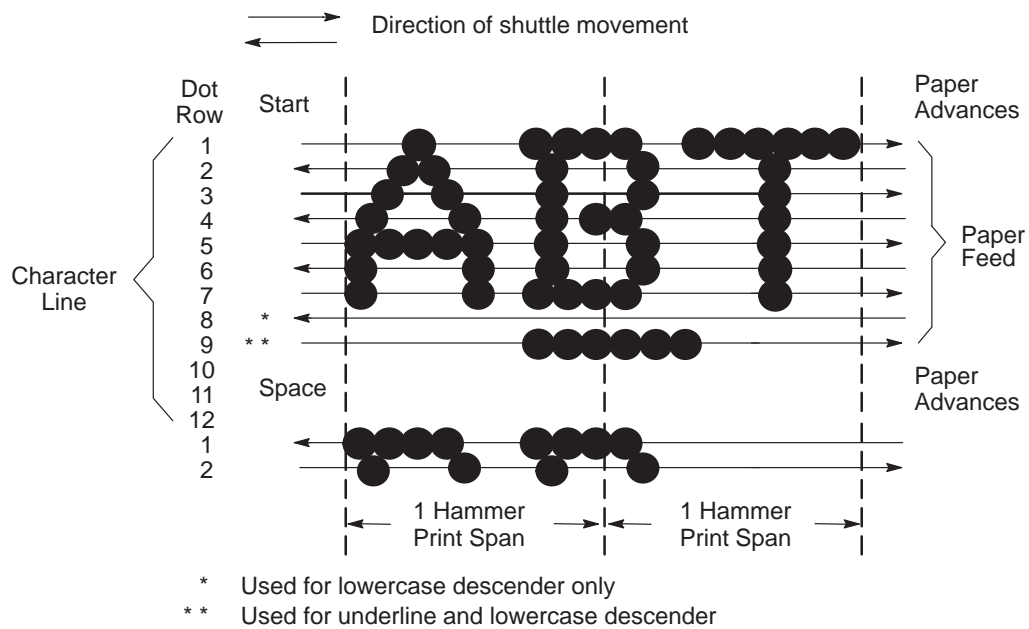

**Figure B-1. Typical Character Formation**

Serial matrix printers use a moving printhead with pins to form single characters sequentially along the printed line. Unlike serial matrix printers, the IBM 6400 is a *line* matrix printer. Line matrix printers divide every printable line into *horizontal* dot rows, then print a dot row of the entire line at every lateral sweep of the shuttle.

During each sweep of the shuttle, hammers are activated to print dots at the required positions in the dot row. When the shuttle reaches the end of a sweep, it reverses direction, and the paper advances one *dot* row. The hammers print the next row of dots as the shuttle sweeps in the opposite direction, as shown in Figure B-2, unless unidirectional printing is chosen.

After a line of characters is printed, the paper advances to the first dot row of the next print line. This creates a number of blank rows between lines of characters, depending on the print mode and line spacing you selected.



**Figure B-2. Line Matrix Printing**

## Printing Speed

---

The speed of text printing is measured in lines per minute (lpm). This speed is dependent upon the number of dot rows required to produce a line of characters, regardless of the number of characters in the line. Because more dot rows are required to print lowercase characters with descenders, those character lines will print at a fractionally lower rate.

In addition to character printing, the printer can plot dot-addressable graphic images. The speed of graphics plotting is measured in inches per minute (ipm). Unidirectional plotting can produce better print quality and takes about twice as long as bi-directional plotting. You can select either plotting mode from the operator panel or from the host computer.

Printing rates also vary according to the print quality you select. For example, if you select the Near Letter Quality (NLQ) option, the printer uses more dot rows and slower print strokes to form characters than if you choose the Draft Quality option. Character formation and print speed are faster in Draft Quality because the printer uses fewer dot rows to form characters.

Printing rates are listed in Appendix A, "Printer Specifications."

# C Host Attachment

## Contents

---

Host Attachment .....	C-2
Compatibility and Limitations .....	C-5

## Host Attachment

---

The following paragraphs provide information that will help you plan your attachment of this printer to your system. (Refer to Table C-1 for special system requirements.)

This printer attaches to the following host devices and workstations:

- AS/400 ASCII Workstation Controller port 9402 (except Model Y10), 9404, and 9406
- 3174 Controller–Asynchronous Emulation Adapter
- IBM Personal Computer and PS/2 Systems–ASCII Serial or Parallel port
- IBM Personal Computer compatible systems–ASCII Serial or Parallel port
- IBM RISC System/6000–ASCII Serial or Parallel port
- Extended System/9370 ASCII Subsystem
- Micro Channel 370–ASCII Serial or Parallel port
- Non-IBM systems that support ASCII attachments through the following interfaces: EIA-232-E Serial, EIA-422-A Serial, PC Parallel, Dataproducts Parallel, and IEEE 1284 Parallel
- Ethernet and Token Ring LANs via the Network Print Server features.

**NOTE:** When a coax/twinax feature is installed, it attaches to host devices and workstations that support coax/twinax.



**Table C–1. Operating System Support**

Operating Systems Supported	Special Notes/Requirements
AIX	<ul style="list-style-type: none"> <li>• Supported by Version 3.1.5 or later.</li> </ul>
AS/400*	<ul style="list-style-type: none"> <li>• Printer attachment: ASCII Workstation Controller on 9402 (except Model Y10), 9404 and 9406</li> <li>• Model 9402 (except Model Y10) supported by Version 3.0, models 9404 and 9406 supported by Version 2.0 or later.</li> <li>• Also supported by PC Support/400, Version 2, Release 3.0.</li> <li>• Also supported by OS/400 Version 2, Release 3 Host Print Transform and OS/400 Version 2, Release 2.</li> </ul>
MS–DOS**	<ul style="list-style-type: none"> <li>• Supported by Version 3.3 or later.</li> <li>• Also supported by Microsoft Windows Version 3.0 or later.</li> </ul>
OS/2*	<ul style="list-style-type: none"> <li>• Supported by: OS/2 Version 2.1 or later, OS/2 LAN Server Version 1.0, OS/2 Extended Services Version 2.1, and OS/2 Communications Manager Version 1.0.</li> </ul>
System 370 and 390 (MVS, VM and VSE Environments)	<ul style="list-style-type: none"> <li>• Existing non–graphics printing applications for the IBM 4234 (Model 001) and IBM 3262 (Models 3, 13) are supported and can be used with this printer.</li> <li>• Supported by 3174 with AEA release A5.4 or later, Release B4.0 or later, and Release C1.1 or later.</li> </ul>
<i>Continued on next page</i>	

Operating Systems Supported	Special Notes/Requirements
Other Operating Systems	<ul style="list-style-type: none"> <li>• Supported by other operating systems through attaching this printer to the following interfaces: EIA-232-E Serial, EIA-422-A Serial, PC Parallel, Dataproducts Parallel, and IEEE 1284 Parallel.</li> <li>• When attaching this printer to a Digital Equipment Corporation** VAX machine, the preferred attachment is through EIA-232-E serial interface.</li> </ul>

**NOTE:** For more specific information, refer to either the *6400 ASCII Programmer's Reference Manual*, or the *6400 Coax/Twinax Programmer's Reference Manual*.

## Compatibility and Limitations

---

The following are some compatibility and limitation considerations you should be familiar with before attaching this printer with your system.

### Compatibility

- The Proprinter III XL emulation is very similar to the datastream used by the IBM 4202–003 Proprinter but contains more features. This protocol enables this line matrix printer to closely emulate a moving-head serial matrix printer but does not support downloaded fonts. In addition, NLQ compresses to 17.1 CPI, not 20 CPI.
- The Epson–FX emulation does not support downloaded characters or print justification. In addition, near letter quality (NLQ) compresses to 17.1 CPI not 20 CPI.
- For Printronix P–Series emulation, differences in supported fonts and control codes may exist between the IBM 6400 and Printronix printers. Downloaded character overlays and downloaded character sets are not supported. Detailed information on supported fonts and control codes can be found in the *6400 ASCII Programmer's Reference Manual*.
- For Printronix P–Series XQ Variant, the IBM 6400 only prints condensed print at 15 CPI, like the Printronix P600, but unlike the P300, which printed condensed print at either 13.3 or 16.7 CPI.
- Emulation differences may exist between the IBM 6400 with Epson FX 1050 emulation and the Printronix MVP 150B, which used the Epson MX emulation.
- Application differences may exist between the IBM 6400 and the Printronix MVP–150C printers due to additional print quality modes which the 6400 does not support.
- Printronix printers with an “L” in the model design indicate the printer has the capability to print smaller dots. The IBM 6400 will print text-only applications that were printed by L–Series printers. Applications requiring the printing of anything other than text will not be supported.
- DAVFU, DVVU, NVFU and CVFU Vertical Format Units, along with the optional uses of the Serial Data Bit 8, are not supported.
- Printronix P6XX0 models using older C1 controllers, which are primarily installed in Europe, are not supported.
- The following printers, which are similar to Printronix printers, are not supported by the IBM 6400 printer: KPG Panda, TRILAx (Trilog Inc.) and Gentry REVerse Paper Feed.

- The IBM 6400 does not support compatibility with the Printronix P1013 or the P4160.
- Printronix printers with the following interfaces are not supported: S/370 Channel Attachment (Printronix P9012), QMS\*\* 2780 or 3780 Bisynd-to-ASCII attachment, RS-232 as Current Loop, and Dataproducts Long Lines.

## Limitations

- Forms length maximum of 24 inches. In the cabinet models, forms longer than 12 inches can be accommodated by opening the front and rear doors.
- Maximum forms width of 17 inches (including tear strips) or 16 inches (without tear strips).
- Use 15 to 100 pound (6.8 to 45.36 kg) stock with a maximum thickness of 0.025 inches (0.0635 cm).
- Maximum print line of 13.6 inches.
- Friction feed paper handling is not supported.
- Use of high speed (Draft mode) fonts using greater than 15 CPI for critical applications should be tested, prior to production use, using your application to determine if the output is satisfactory.
- Processing of forms with black or dark colored backing, or forms with see-through plastic or cellophane covered openings or windows may give false End-of-Forms (EOF) signals. Request For Price Quote (RPQ) S02392 (factory-installed) or S02394 (field-installed) may be ordered to provide a modified EOF switch to handle these types of forms. Contact your IBM Sales Representative or IBM Authorized Remarketer.
- Downloaded characters are not supported in Proprinter, Epson, P-Series, P-Series XQ Variant, or Printronix Serial Matrix emulations.
- Due to the variation in carbonless forms, you should test forms with four or more parts for readability prior to production use. Carbonless forms can be affected by storage and other environmental conditions and should be tested periodically from your application to make sure the output meets your requirements.
- Compatibility differences may exist when replacing or coexisting with older printers due to technology differences, product and application customization, and emulation differences.

- The IBM Coax/Twinax feature will not support P-series or EVFU control codes coming from the host. The IBM Coax/Twinax feature may not be compatible with some older applications running on an installed Printronix printer. In that case, the Multi-Platform Interface Coax/Twinax feature should be installed.
- The coaxial portion of the IBM Coax/Twinax feature of this printer is subject to the following limitations, and the following features are not supported:
  - Minimum dot matrix of 9 wide by 8 high
  - Minimum dot matrix of 4 or 7 wide by 8 high
  - IBM 3287 Models 1C and 2C
  - Programmed symbols 2 and 4, 190 character downloadable fonts
  - For SCS/DSC/DSE mode only
  - Data analysis = APL feature
  - Graphic escape
- The twinaxial portion of the IBM Coax/Twinax feature of this printer is subject to the following limitations, and the following features are not supported:
  - Minimum dot matrix of 9 wide by 8 high
  - Minimum dot matrix of 4 or 7 wide by 8 high
  - Print lines greater than 198 characters
- IBM 6400 vs 4234 IPDS Comparisons — 4234 Emulation Differences
  - The 4234 emulation will not support Load Symbol Sets (LSS)
  - The 4234 emulation will use Courier for all Near Letter Quality (NLQ) mode printing, whereas 4234 NLQ mode was Gothic for 13.3, 16.7 and 18 CPI.
  - The dot sizes are different. Also, the 6400 has a single dot size vs three with the 4234. For bar code applications, some combinations of unit module width, wide-to-narrow ratio, and element height may affect read rates.
  - The 4234 emulation will support image and font resolution of 120 x 144 pel, compared to 144 x 144 pel in the 4234. This will cause images to change size in the vertical dimension.
- Proportional Space Mode (PSM) is not the same. Some differences will occur.

- IBM 6400 vs. 4234 IPDS Comparisons — Differences:

The 6400 will report Loaded Font command set (LF2) in the Sense Type Module (STM), but will not support Load Symbol Set (LSS).

The 6400 will support Page Continuation Actions (PCA) without highlighting.

The 6400 cannot detect Human Readable Integers (HRI) outside of the Bar Code Presentation space under all circumstances.

- The Multi-Platform Interface Coax/Twinax feature of this printer is subject to the following limitations and the following features are not supported:

You must select either coax or twinax attachment: only one can be active at one time. You can also use the Centronics Parallel interface for attachment of a LAN or PC.

Coax and twinax error detection and recovery is limited to those errors associated with the Centronics Parallel interface.

**NOTE:** For information on differences between this printer's data stream emulations and other printer data streams, such as the IBM Proprinter III XL, please refer to the *6400 ASCII Programmer's Reference Manual*.

# D

## Code V, IGP, and IPDS Menus

### Contents

---

Code V Feature (IGP/VGL) .....	D-4
Configuration .....	D-4
Code V Parameters .....	D-4
Code V Configuration Menu .....	D-5
Select SFCC .....	D-6
Power On ^X .....	D-6
Power On ^F .....	D-6
Power On ^PY .....	D-6
Lines Per Inch .....	D-7
Graphics Options .....	D-7
Error Handling .....	D-10
Character Filtering .....	D-10
Font Set .....	D-12
PI Control .....	D-12
IGP Feature (IGP/PGL) .....	D-13
Configuration .....	D-13
IGP Parameters .....	D-13
IGP Configuration Menu .....	D-14
Define CR Code (Carriage Return) .....	D-15
Define LF Code (Line Feed) .....	D-15
Auto LF .....	D-15
Select SFCC .....	D-15
PI Slew Range .....	D-16
CR Edit .....	D-16
Select Font .....	D-16

Lines Per Inch .....	D-17
Mono/Dual Case .....	D-17
Skip Command Prefix .....	D-17
Power On IGP .....	D-17
Extended Execute Copy .....	D-18
UPC Descenders .....	D-18
Compressed 17 CPI .....	D-18
Ignore Character .....	D-18
IGP100 Compatibility .....	D-19
Expanded Scalable .....	D-19
Optimized Ratio .....	D-19
IPDS Feature .....	D-20
Configuration .....	D-20
IPDS Parameters .....	D-20
IPDS Configuration Menu .....	D-21
Early Print Complete .....	D-22
Override Host .....	D-22
Graphics Quality .....	D-23
Bar Code Quality .....	D-23
Image Quality .....	D-23
IPDS Emulation Mode .....	D-24



## **Code V, IGP, and IPDS Menus for Optional Features**

---

If you have installed these features, the following menus can be accessed from the operator panel. These menus appear only if the feature is installed. The following sections are brief descriptions of the menu selections for each feature and are provided here as a quick reference to these feature menus.

For detailed information on these menu selections, refer to the documentation that was shipped with the feature.

Code V and IGP with twinax require that the IBM Twinax emulation be set to 4234-2 or 5225.

## Code V Feature (IGP/VGL)

---

### Configuration

Matching printer operational settings to those of the host computer is known as printer configuration. The settings, or configuration parameters, such as selecting the host interface, are adjusted according to the configuration instructions in Chapter 3, “Configuring the Printer.” Configure the Code V feature in the same way you would configure the printer for other features.

You can select Code V parameters directly from the operator panel as explained in this chapter, or by control codes as explained in the *6400 Code V User’s Manual*.

### Code V Parameters

The Code V parameters are described on the following pages. Parameters marked with an asterisk (\*) indicate the default value. The printer must be off-line to enter the configuration structure.

Enter and exit the Code V configuration menu according to the steps outlined in Chapter 3, “Configuring the Printer.” Pressing an invalid key to enter a parameter value may move you to another level in the configuration or exit the configuration menu completely.

#### IMPORTANT

**BEFORE you reconfigure the Code V, print a configuration sheet to see all of the current settings. Refer to Chapter 3, “Configuring the Printer.”**

Configure the Code V according to your specific requirements.

The Code V configuration menu is shown in Figure D-1 on the following page.

# Code V Configuration Menu

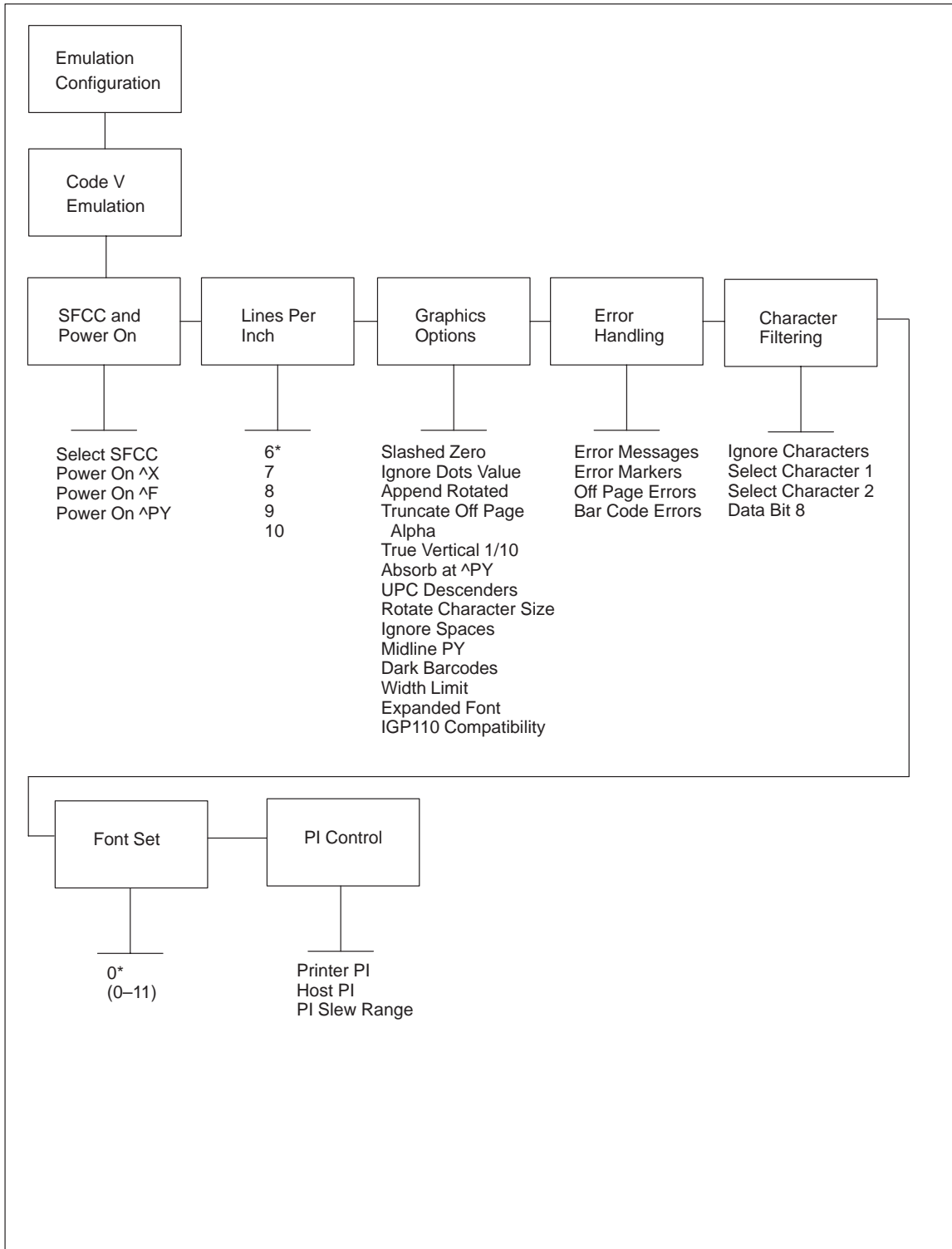

Figure D-1. Code V Configuration Menu

## Select SFCC

Selects the Special Function Control Character. Valid values are 11 (hex) to FF (hex). The default value is 5E (hex). Always use the SFCC required for your configuration wherever the circumflex, or (cc) is shown. Obtain a configuration printout to determine the currently selected SFCC.

## Power On ^X

- **Disable.** The default. Does not select the ignore mode as the power-up default.
- **Enable.** Selects the ignore mode as the power-up default, and selects the graphics mode (cc)PY as the power-up default. All characters are ignored until a (cc)A command is received.

Refer to the *6400 Code V User's Manual* for more information.

## Power On ^F

Enable Free format causes the Code V to ignore carriage returns, line feeds and all characters below 20 hex sent from the host. Refer to the *6400 Code V User's Manual* for more information on Free Format.

- **Disable.** The default. Does not select free format as the power-up default.
- **Enable.** Selects free format as the power-up default, and selects the graphics mode (cc)PY as the power-up default.

## Power On ^PY

- **Disable.** The default. Does not select the graphics mode (cc)PY as the power-up default.
- **Enable.** Selects the graphics mode (cc)PY as the power-up default.

Refer to the *6400 Code V User's Manual* for more information.

## Lines Per Inch

Defines the number of lines per inch for the Code V to use. Can also be set by using the ^@L command. The following number of lines per inch may be selected:

- **6** (the default)
- **7**
- **8**
- **9**
- **10**

## Graphics Option

### Slashed Zero

- **Disable**. The default. Prints zeros without a slash (0).
- **Enable**. Prints zeros with a slash (Ø) to distinguish zeros from the alphabetical capital “O.”

### Ignore Dots Value

- **Disable** (the default)
- **Enable**. Causes the Code V to expect position values to be specified in only 1/10 of an inch. If the dot position is also given, it is treated as text.

### Append Rotated

- **Disable**. The default. Appends logos to an alphanumeric string rotated in a clockwise, counterclockwise, or inverted orientation.
- **Enable**. When enabled, the logo is treated as a separate element.

### Truncate Off Page Alpha

When enabled, this parameter prevents the printing of Error 48 (Element Off Page Error) if alphanumeric data, including spaces, extends beyond the right side of the form.

- **Disable**
- **Enable** (the default)

### **True Vertical 1/10**

Determines if a vertical 1/10 of an inch parameter is used as 1/10 of an inch (Enabled) or as 7/72 of an inch (Disabled). When used as 1/10 of an inch, rounding will occur to the nearest 1/72 of an inch. This can cause vertical moves that have the same value to differ by  $\pm 1/72$  of an inch. When used as 7/72 of an inch, the absolute move is slightly smaller than expected. For example, a one inch move would be 70/72 of an inch. Vertical moves that have the same value will be identical in length.

- **Disable** (the default)
- **Enable**

### **Absorb at ^PY**

- **Absorb Motion.** The default. Prevents paper motion following a system terminator in a graphics (cc)PY command.
- **Disable.** When disabled, system terminators following a graphics command are sent to the printer and result in paper motion.
- **Absorb All.** When absorb all is selected, the system ignores all the data and terminator until a host generated terminator is detected.

### **UPC Descenders**

This parameter determines if a gap is left for human readable data in UPC/EAN bar codes, even if there is no human readable data. There will be no change if there is human readable data.

- **Enable.** The default. Leaves a gap even if there is no human readable data.
- **Disable.** Does not leave a gap if there is no human readable data.

### **Rotate Character Size**

The Rotated Character Size option determines if rotated (clockwise/counter-clockwise), expanded characters have a different size than an unrotated character with the same size parameters (Adjusted) or the same size (Not Adjusted).

- **Adjusted** (the default)
- **Not Adjusted**

### **Ignore Spaces**

- **Disable.** The default. Trailing spaces are NOT deleted from alphanumeric elements in a graphics pass.
- **Enable.** Trailing spaces are deleted from alphanumeric elements in a graphics pass.

### **Midline PY**

- **Enable.** Allows printable characters to precede the ^PY command.
- **Disable.** The default. Requires the ^PY command to be the first characters on a line.

### **Dark Barcode**

- **Disable.** The default. Barcodes are printed in normal mode.
- **Enable.** When enabled, prints all barcodes in a dark mode.

### **Width Limit**

- **Disable.** The default. This does not limit the width of expanded characters.
- **Enable.** When enabled, limits the width of expanded characters based on a fixed maximum ratio of width over height.

### **Expanded Font**

- **Scalable:** The default. These expanded characters have rounded edges.
- **Block:** These are block characters compatible with the IGP-X00 printers.

### **IGP110 Compatibility**

- **Enable.** This menu will process ^IPEXP commands in the same manner IGP does, and does not expand special font characters if an ^IPEXP command precedes it.
- **Disable.** The default. If disabled, it will allow the special font characters to be expanded.

## Error Handling

### Error Messages

- **Disable.** Suppresses error checking and error messages.
- **Enable.** The default. Checks command syntax and error messages printed when command parameters are incorrect.

### Error Markers

- **Enable.** The default. Prints the following error markers for those elements that print beyond the page boundaries:
  - >> for elements that begin off the right side of the page;
  - << for elements that begin at the indicated position but end off the page;
  - for elements where the starting position of the command contains an error other than an off-page error.
- **Disable.** Does not print error markers for those elements that print beyond the page boundaries.

### Off Page Errors

- **Disable.** The default. Does not report errors for elements that start or end beyond the right edge of the page.
- **Enable.** Reports errors for elements that start or end beyond the right edge of the page.

### Bar Code Errors

- **Enable.** The default. Prints an error message when invalid bar code data is encountered.
- **Disable.** Does not print an error for invalid bar code data and the bar code will be printed as is.

## Character Filtering

### Ignore Characters

Determines if character filtering is enabled, or if one or both characters are ignored.



- **Disable.** The default. Does not ignore the characters selected with the select character options.
- **Character 1.** The character selected using the Select Character 1 option will be ignored in the data string.
- **Character 2.** The character selected using the Select Character 2 option will be ignored in the data string.
- **Character 1 and 2.** Both characters selected using the Select Character 1 and Select Character 2 options will be ignored in the data string.

### Select Character 1

Selects character 1 for the character filtering option. Valid values are from 0 to 255 (decimal). The default value is 0.

### Select Character 2

Selects character 2 for the character filtering option. Valid values are from 0 to 255 (decimal). The default value is 0.

### Data Bit 8

- **Enable.** The default. The PI line is not passed directly from host to printer; all 8 bits are used for data bits, and characters in the 80–FF hex range can be accessed.
- **Disable.** When the host PI line is enabled, indicates PI line status. To use the PI line, disable data bit 8, and enable the Host PI configuration option.

**NOTE:** Data bit 8 is interpreted as *either* data bit 8 or PI signal, but never both. When enabled as data bit 8, data bit 8 has priority over the PI signal, and all data above 7F hex is used to access character data and not to interpret PI line data.

Conversely, when data bit 8 is disabled and the PI signal is used, data bit 8 of the data is reserved for use as the PI function, and you cannot access characters in the 80–FF hex range. Therefore, to access characters in the 80–FF hex range, data bit 8 *must* be enabled.

## Font Set

This parameter allows you to select a font for the Code V feature. The default is 0, which is U.S. ASCII. The following values are valid choices:

0	U.S. ASCII
1	German
2	Swedish
3	Danish
4	Norwegian
5	Finnish
6	English
7	Dutch
8	French
9	Spanish
10	Italian
11	Turkish

## PI Control

### Printer PI

- **Disable.** The default. Does not inform the Code V that the ASCII emulation is configured with the PI line enabled.
- **Enable.** Informs the Code V that the ASCII emulation is configured with the PI line enabled.

### Host PI

- **Disable.** The default. The Data Bit 8 configuration option must be disabled to transmit the PI line to the printer.
- **Enable.** Informs the Code V that the host sends PI signals.

### PI Slew Range

This parameter determines if the range for a paper slew is from 1 to 15 lines or 1 to 16 lines.

- **Enable.** The default. A paper slew of 0–15 will move 1–16 lines.
- **Disable.** A paper slew of 1–15 will move 1–15 lines. A paper slew of 0 will move 1 line.

## IGP Feature (IGP/PGL)

---

### Configuration

Matching printer operational settings to those of the host computer is known as “printer configuration.” The settings, or configuration parameters, such as selecting the host interface, are adjusted according to the operator panel key descriptions in your *Operator’s Guide*. Configure the IGP feature in the same way you would configure the printer for other features.

You can select IGP default parameters directly from the operator panel as explained in this chapter, or by control codes as explained in the *6400 IGP User’s Manual*.

### IGP Parameters

The IGP parameters are described on page D–14 and the following pages. Parameters marked with an asterisk (\*) indicate the default value. The printer must be off–line to enter the configuration structure.

Enter and exit the IGP configuration menu according to the configuration procedures in Chapter 3, “Configuring the Printer.” Pressing an invalid key to enter a parameter value may move you to another level in the configuration or exit the configuration menu completely.

#### IMPORTANT

**BEFORE you reconfigure the IGP, print a configuration sheet to see all of the current settings. Refer to Chapter 3, “Configuring the Printer.”**

Configure the IGP according to your specific requirements.

The IGP configuration menu is shown in Figure D–2 on the following page.

# IGP Configuration Menu

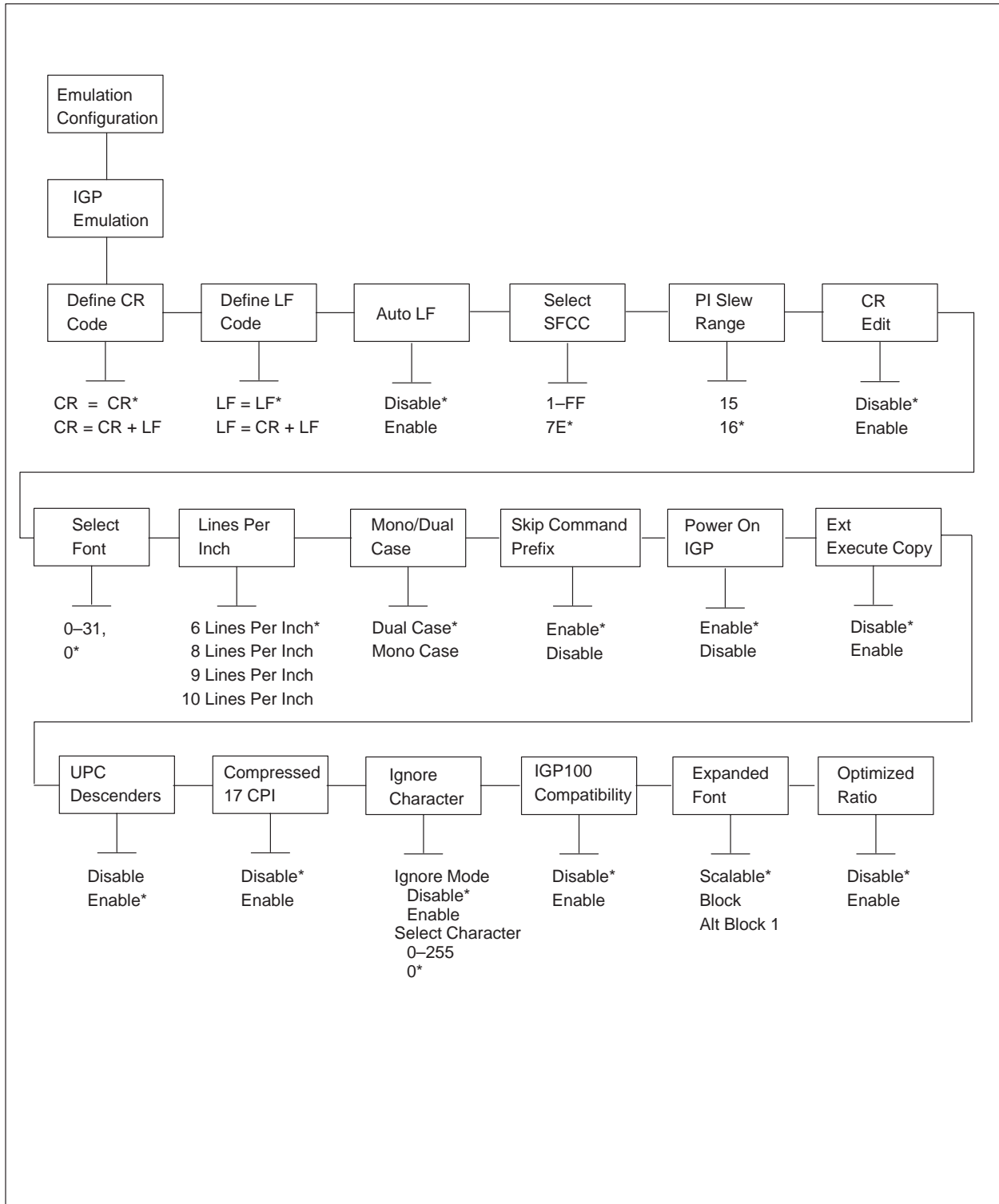

Figure D-2. IGP Configuration Menu

### Define CR Code (Carriage Return)

This parameter forces the printer to insert an automatic Line Feed code into the data stream whenever a Carriage Return code occurs. This is to be used only if the host computer does not send Line Feeds to the printer.

- **CR = CR.** The default. Does NOT perform a line feed. The next print position will be print position 1 of the current line.
- **CR = CR + LF.** Performs an automatic line feed. The next print position will be print position 1 of the next line.

### Define LF Code (Line Feed)

This parameter forces the printer to insert an automatic Carriage Return code into the data stream whenever a Line Feed code occurs. This can be used in most installations, but it is required if the host computer does not send Carriage Returns to the printer.

- **LF = LF.** The default. Does not perform an automatic carriage return. The next print position will be the current print position of the next line.
- **LF = CR + LF.** Performs an automatic carriage return. The next print position will be print position 1 of the next line.

### Auto LF

This parameter determines if text will wrap to the next line when the line of text exceeds the right margin.

- **Disable.** The default. Truncates the text beyond the right margin until a CR or CR + LF is received.
- **Enable.** Automatically inserts a CR + LF after a full print line.

### Select SFCC

You can specify which hex code (1–FF) will be used as the Special Function Control Character (SFCC). The factory default setting is 7E. The SFCC denotes that the following data is an IGP command.

## PI Slew Range

You can specify how many lines the paper will feed.

- **15.** A paper slew of 1–15 will move 1–15 lines. A paper slew of 0 will move 1 line.
- **16.** The default. A paper slew of 0–15 will move 1–16 lines.

## CR Edit

This parameter determines if a carriage return will be followed by a line feed.

- **Disable.** The default. The printer ignores all carriage returns that are not followed by line feeds.
- **Enable.** The printer processes all carriage returns, even for those that are not followed by line feeds.

## Select Font

This parameter allows you to select a font for the IGP feature. The default is 0, which is U.S. ASCII. The following values are valid choices:

0	U.S. ASCII
1	German
2	Swedish
3	Danish
4	Norwegian
5	Finnish
6	English
7	Dutch
8	French
9	Spanish
10	Italian
11	Turkish

Values 12–23 are undefined and will default to 0. You can set values 24–31 to specific fonts; refer to the USET command.

### Lines Per Inch

This is the number of lines to be printed per inch. For example, at 6 lpi there is 1/6–inch from the top of one print line to the top of the next print line. The following number of lines per inch may be selected:

- **6** (the default)
- **8**
- **9**
- **10**

### Mono/Dual Case

This parameter enables the printer to print text in all uppercase when using the ALPHA command.

- **Dual Case.** The default. The printer will print text in upper- and lowercase.
- **Mono Case.** The printer will print text in uppercase only.

### Skip Command Prefix

This parameter determines if a data string before an IGP command will be ignored.

- **Disable.** The printer will print any data before an IGP command.
- **Enable.** The default. The printer ignores all text before an IGP command.

### Power On IGP

You can set the IGP feature so that it is enabled or disabled when the printer is powered on.

- **Disable.** The IGP is disabled when the printer is powered on. (The IGP feature is initialized to the Quiet mode.)
- **Enable.** The default. The IGP is enabled when the printer is powered on. (The IGP feature is initialized in the Normal mode.)

## Extended Execute Copy

- **Disable.** The default. Dynamic data, overlay data, etc. are not allowed if the optional Form Count parameter (number of forms to print) is specified as part of the Execute command. (This setting is IGP–100/200/400 compatible.)
- **Enable.** Dynamic data, overlay data, etc. are allowed within a form in which the Form Count parameter is specified in the Execute command. In this case, the exact same form (with identical dynamic data, etc.) is printed for whatever the Form Count is. However, incremental data is *not* incremented since the page that is printing is exactly the same. Also, each form is printed on a separate page.

## UPC Descenders

This parameter determines if a gap is left for human readable data in UPC/EAN bar codes, even if there is no human readable data. There will be no change if there is human readable data.

- **Disable.** The IGP does not leave a gap if there is no human readable data.
- **Enable.** The default. The IGP leaves a gap, even if there is no human readable data.

## Compressed 17 CPI

This parameter allows you to choose a compressed character for 17 CPI instead of the normal height character.

- **Disable.** The default. The IGP does not use the compressed 17 CPI font.
- **Enable.** The IGP uses the compressed 17 CPI font.

## Ignore Character

### Ignore Mode

This parameter instructs the IGP to ignore the character selected under the Select Character menu.

- **Disable.** The default. The IGP does not ignore any characters.
- **Enable.** The IGP ignores the characters selected under the Selected Character menu.



### Select Character

This instructs the IGP which character to ignore from the host. Valid selections are from 0–255. The default is 0.

### IGP100 Compatibility

This option instructs the IGP to behave similarly to the 100 version of the IGP with respect to certain commands.

All new users with new applications should select the “Disable” option. Selecting this mode insures the printer will behave as described in this manual. The other version is required to emulate the behavior of IGP100 printers that may be inconsistent with the documented PGL functionality.

When replacing an older product operating with an existing application, especially those using the PMODE and SMODE commands, the IGP100 mode may need to be selected.

- **Disable.** The default. The IGP does not emulate the IGP100 mode.
- **Enable.** The IGP emulates the IGP100 version.

### Expanded Font

This option defines the type of expanded character the IGP/PGL will select. The following choices are:

- **Scalable:** The default. These expanded characters have rounded edges.
- **Block:** These are block characters compatible with the IGP–X00 printers.
- **Alt Block 1:** This is a customized block character set that is only available for the non–overlay multinational group of character sets.

### Optimized Ratio

This option selects different barcode ratios for certain barcodes including Code 39 and interleaved 2 of 5. It is included for compatibility with IGP–X00 printers.

- **Disable.** The default. Use standard barcode ratios.
- **Enable.** Select the alternate barcode ratios.

## IPDS Feature

---

### Configuration

Matching printer operational settings to those of the host computer is known as “printer configuration.” The settings, or configuration parameters, such as selecting the host interface, are adjusted according to the operator panel key descriptions in your *Operator’s Guide*. Configure the IPDS in the same way you would configure the printer for other features.

You can select IPDS default parameters directly from the operator panel as explained in this chapter, or by control codes as explained in the *6400 IPDS Programmer’s Reference Manual*.

**NOTE:** The IPDS feature is not available with the Multi-Platform Interface Coax/Twinax feature.

### IPDS Parameters

The IPDS parameters are described on page D-21 and the following pages. Parameters marked with an asterisk (\*) indicate the default value. The printer must be off-line to enter the configuration structure.

Enter and exit the IPDS configuration menu according to the configuration procedures in Chapter 3, “Configuring the Printer.” Pressing an invalid key to enter a parameter value may move you to another level in the configuration or exit the configuration menu completely.

#### **IMPORTANT**

**BEFORE you reconfigure the IPDS, print a configuration sheet to see all of the current settings. Refer to Chapter 3, “Configuring the Printer.”**

Configure the IPDS according to your specific requirements.

The IPDS configuration menu is shown in Figure D-3 on the following page.

# IPDS Configuration Menu

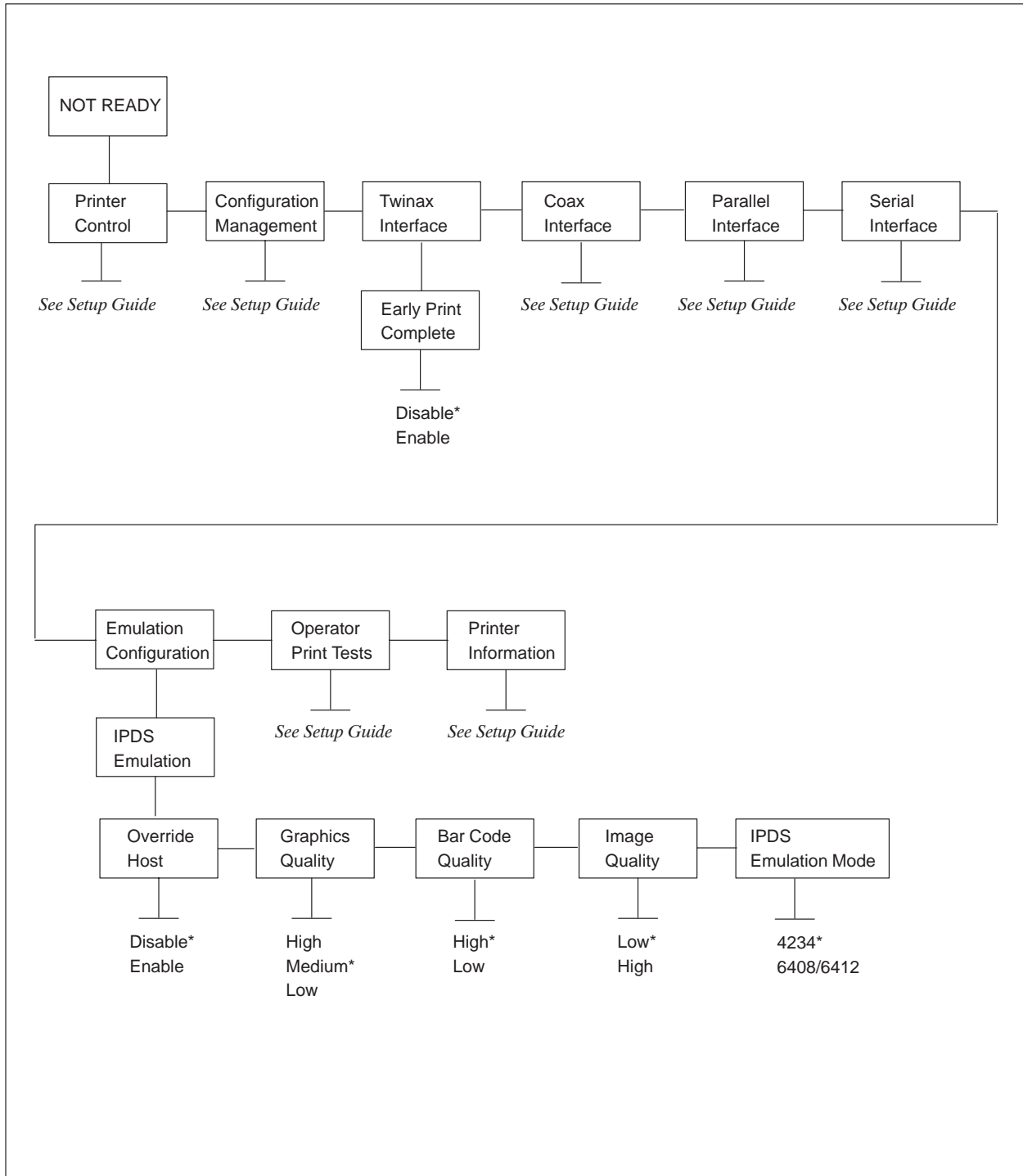

Figure D-3. IPDS Configuration Menu

## Early Print Complete

Early Print Complete is accessed under the Twinax Interface menu selection. The value described below only applies to IPDS and Twinax; this does not apply to Early Print Complete under Coax Interface, which is a separate function. Early Print Complete is used to determine when the next print job can be sent to the printer. Do not select Early Print Complete while a print job is in process. If you do, you will need to restart the printer.

- **Disable.** The default. The printer waits for the system or controller to finish a job before issuing a print complete status. The spool file is not released until printing is completed. This can cause the printer to print at less than rated speed but can help ensure that all data is printed.
- **Enable.** The printer does not wait for the system or controller to finish a job before issuing a print complete status. The spool file can be deleted before printing is completed. This can cause the printer to print at rated speed but some data, particularly the last few lines, of the last print job may be lost.

## Override Host

Override Host determines if the operator panel overrides specified IPDS menu values.

Select one of the following two values:

- **Disable.** The default. Does not allow operator panel settings to override IPDS application commands.
- **Enable.** Allows operator panel settings to override IPDS application commands.

The specified IPDS application commands for the IPDS menu values are:

- Graphics Quality
- Bar Code Quality
- Image Quality

**NOTE:** No other IPDS menu values or printer operator panels are affected by Override Host. Only the three values listed above are affected.

## Graphics Quality

Determines the quality for graphics printing. Override Host must be enabled to use these settings. Here are the supported resolutions in pels:

- **High.** Vertical is 144; horizontal is 180.
- **Medium.** The default. Vertical is 144; horizontal is 120.
- **Low.** Vertical is 72; horizontal is 60.

**NOTE:** The higher the resolution selected, the slower the print speed. When selecting a resolution, try to balance the resolution quality your application requires with how fast you want the print job to print.

## Bar Code Quality

Determines the quality for graphics printing. Override Host must be enabled to use these settings. Below are the values for non-rotated bar codes.

- **High.** The default. Vertical is 144; horizontal is 120.
- **Low.** Vertical is 72; horizontal is 60.

**NOTE:** The higher the resolution you select, the slower the print speed. When selecting a resolution, try to balance the resolution quality your application requires with how fast you want the print job to print.

## Image Quality

Determines the quality for image printing. Override Host must be enabled to use Image Quality. If Override Host is disabled, then the image is assumed to be 144 by 144 and the image is printed at 120 by 144.

- **High.** Accepts images with 120 by 144 and prints images 120 by 144. With this setting, the image is printed as is and requires no conversion. Because no conversion is required, there is more fidelity between the original image and the printed image.
- **Low.** The default. Accepts images with 144 by 144 and prints images at 120 by 144. With this setting, the image is converted from 144 by 144 to 120 by 144. Since there is some conversion required, there may be some differences between the original image and the printed image. Review the note below for more information.

**NOTE:** There is one bit of image data per pel. If your print job contains an image created to print 144 by 144, which is very common for IBM 4234 printers, some bits of data will be dropped out to support the best fit resolution, which is 120 by 144.

When printing jobs with images created for an IBM 4234 printer, you will want to print a few samples to ensure the results are satisfactory.

### **IPDS Emulation Mode**

Select which type of printer you want IPDS to support. You can choose either to emulate a 4234 or you can choose 6408/6412. You should choose which mode you use based on your software applications. For instance, if you are using PSF/MVS, then you would choose 6408/6412 as PSF/MVS provides support for this printer.

- **4234.** The default. IPDS supports 4234 printer functions. This is the default which should be used most often. If you are using IPDS with PSF applications, except PSF/MVS, make sure you select 4234.

Please review Chapter 3, “IPDS Commands Reference” in your *6400 IPDS Programmer’s Reference Manual* for information on using IPDS commands when you select 4234 from the IPDS Emulation Mode menu.

- **6408/6412.** IPDS supports 6408/6412 printer functions. Use this value when you are using IPDS with PSF/MVS. This value enables IPDS and PSF/MVS to take advantage of 6408/6412 printer functions which are supported directly by PSF/MVS. (Other PSF applications only support this printer as a 4234 printer.)

Please review Chapter 4, “IPDS Command Differences” in your *6400 IPDS Programmer’s Reference Manual* for information on using IPDS commands when you select 6408/6412 from the IPDS Emulation Mode menu.

**NOTE:** If you want to use the value 6408/6412 as the default value, you will need to select 6408/6412 as the default, save the value as a custom set, and then power the printer off and back on again.

# Glossary

## A

- A to D** Analog to Digital.
- active column** The horizontal location on the paper where the next character will print. After printing a character, the printer advances the active column.
- active line** The vertical location on the paper where the next character will print. After printing a line, the printer advances the active line.
- active position** The position on the paper where the next character will print. The active position is defined by the horizontal position (active column) and the vertical position (active line).
- ACK** (Positive) acknowledge. Affirmative or acknowledged.
- ASCII** American Standard Code for Information Interchange. A standard character encoding scheme introduced in 1963 and used widely on many computers and printers. It is a 8-bit code with 256 different bit patterns. There is no parity recommendation.
- attributes, print** Operations performed on text that alter its appearance but do not change the font. Examples: underlining, superscripting, bold, etc.

## B

- bar code** A printed code consisting of parallel bars of varied width and spacing and designed to be read by a one-dimensional scanning device.
- baud** A unit of speed that measures the rate at which information is transferred. Baud rate is the reciprocal of the length in seconds of the shortest pulse used to carry data. For example, a system in which the shortest pulse is 1/1200 second operates at 1200 baud. On RS-232 serial lines, the baud rate equals the data flow rate in bits per second (bps). To communicate properly, a printer must be configured to operate at the same baud rate as its host computer.

<b>bold</b>	A print attribute specifying text of a heavy line thickness. <b>This sentence is bold.</b> <i>See also character weight.</i>
<b>buffer</b>	A reserved area in memory where data is written and read during data transfers.
<b>bus</b>	A circuit for the transfer of data or electrical signals between two devices.

## C

<b>character cell</b>	The invisible rectangular space occupied by a character, including the white space around the character. The height of a cell is equal to the current line spacing, and the width is equal to the current character spacing. Used as a unit of spacing.
<b>character proportion</b>	The ratio of character height to character width. <i>See also compressed and expanded.</i>
<b>character set</b>	A set of codes, each of which represents a printable character, including symbols, punctuation, numbers, diacritical markings, and alphabet characters. Each character is assigned a unique code value.
<b>character weight</b>	The degree of lightness and thickness of printed text. For example: <b>“Bold” refers to a heavy or thick character weight.</b> “Medium,” “normal,” or “book weight” refer to the character weight used in this sentence.
<b>checksum</b>	A stored or transmitted numerical value used to verify data integrity.
<b>Code V</b>	An optional QMS emulation which allows you to create and store forms: generate logos, bar codes, and expanded characters; create other graphics, and merge graphics with alphanumeric data as a document is printed.
<b>command</b>	An instruction, such as a form feed command, sent from a computer to the printer (sometimes called a control code or non-printable character). As opposed to data, which is information to be printed.



<b>command delimiter</b>	An ASCII character used to begin a command string (same as SFCC). Commonly used command delimiters are ESC (1B hex) and SOH (01 hex).
<b>command sequence</b>	Two or more bytes that instruct the printer to perform a special function. The first character in the sequence is a special function control character (SFCC), which alerts the printer that the string is a command sequence. <i>See also escape sequence, SSSC, and SFCC sequence.</i>
<b>compatibility</b>	The ability of one printer to accept and properly process commands meant for a different printer. ( <i>See also</i> emulation and protocol.)
<b>compressed</b>	Refers to a typeface with a font width approximately 60% smaller than normal. Character height is not changed.
<b>configuration</b>	Refers to the operating properties that define how the printer responds to signals and commands received from the host computer at the printer interface. These properties are called configuration parameters and must be set to match the operating characteristics of the host computer system.
<b>controller</b>	An independent logic unit in a data processing system that controls data paths between the central processing unit and one or more units of peripheral equipment.
<b>cpi</b>	Characters per inch: a measurement of monospaced fonts indicating the horizontal character density. For example, 10 cpi means 10 characters can be printed in one horizontal inch.
<b>cps</b>	Characters per second: a measurement of the print speed of a serial (character) printer.
<b>CPU</b>	Central Processing Unit.
<b>CR</b>	Carriage Return.
<b>CTØ</b>	<i>Abbrev. for</i> Coax/Twinax only: a model available in a previous generation of the IBM Line Matrix Printer.
<b>CTA</b>	<i>Abbrev. for</i> Coax/Twinax/ASCII.

**CTS** Clear To Send.

**CVFU** *Abbrev. for* Centronics direct access Vertical Format Unit.

## D

**DAVFU** *Abbrev. for* Direct Access Vertical Format Unit. Also known as NVFU. *See also* **NVFU**.

**DC** Data Controller.

**DCD** Data Carrier Detect.

**decipoint** One tenth of a point. A unit of length equal to 1/720 inch. *See also* **point**.

**default** A value, parameter, attribute, or option that is used by a program or system if another is not specified by the user.

**descender** The portion of a printed, lowercase character that appears below the base line. For example, “g,” “j,” “p,” “q,” and “y” all are characters with lowercase descenders.

**diagnostic** Pertaining to the detection and isolation of a printer malfunction or mistake.

**disable** To deactivate, make “false” (0), or set to OFF.

**DP** *Abbrev. for* data processing print. This is a mid-quality, mid-speed print resolution

**draft** A limited dot font used for rough copy. Low print quality but fast printing speed.

**DRAM** Dynamic Random Access Memory.

**DSR** Data Set Ready.

**DTR** Data Terminal Ready.

**DVFU** *Abbrev. for* Dataproducts direct access Vertical Format Unit.

## E

<b>EBCDIC</b>	Extended Binary Coded Decimal Interchange Code.
<b>EC</b>	Engine Controller.
<b>ECMA</b>	European Computer Manufacturers Association.
<b>EIA</b>	Electronic Industries Association.
<b>Elite</b>	A name indicating a monospaced font with a pitch of 12 cpi (and usually 10 points in height).
<b>em</b>	A unit of measure in typesetting: the width of a piece of type about as wide as it is tall. (Derived from uppercase M, usually the widest character in a set.)
<b>EM</b>	End of Message (3287 only).
<b>emulation</b>	The ability of a printer to emulate, or function like, a different type of printer. ( <i>See also</i> compatibility and protocol.)
<b>en</b>	A unit of measure in typesetting equal to half the width of an em.
<b>enable</b>	To activate, make “true” (1), or set to ON.
<b>escape sequence</b>	A command sequence in which the first byte is always the ASCII ESC character. <i>See also</i> <b>command sequence</b> , <b>SSCC</b> , and <b>SFCC sequence</b> .
<b>ETX</b>	End of Text.
<b>EVFU</b>	<i>Abbrev. for</i> Electronic Vertical Format Unit. Relates to the ability to slew (skip quickly a specified number of lines).
<b>expanded</b>	Refers to a typeface with a font width larger than normal. Character height is not changed.

## F

<b>family (or type)</b>	A set of all variations and sizes of a type style.
<b>FF</b>	Form Feed.

<b>FIFO</b>	First In, First Out.
<b>fixed-pitch fonts</b>	Same as FONT, MONOSPACED.
<b>FM Header</b>	Format Header. Command strings used to switch between SCS and IPDS.
<b>font</b>	The complete set of a given size of type, including characters, symbols, figures, punctuation marks, ligatures, signs, and accents. To fully describe a font, you must specify seven characteristics: <ol style="list-style-type: none"> <li>1) typeface (Courier, Helvetica, Swiss, etc.)</li> <li>2) spacing (proportional or monospaced)</li> <li>3) type size (12 point, 14 point, etc.)</li> <li>4) scale factor (character height/width ratio)</li> <li>5) type style (Roman or italic)</li> <li>6) character weight (bold, normal, etc.)</li> <li>7) character proportion (normal, compressed, expanded).</li> </ol>
<b>font, monospaced</b>	Also called fixed-pitch font and mono-font. Every character, regardless of horizontal size, occupies the same amount of font pattern space. All monospaced fonts use specific pitch size settings. Monospaced fonts are sometimes used when strict character alignment is desired (tables, charts, spreadsheets, etc.).
<b>font name</b>	<i>See typeface.</i>
<b>font pattern</b>	A font pattern is the matrix of pixels which represents a character, symbol, or image.
<b>font, proportional</b>	A font in which the width of a character cell varies with the width of the character. For example, [i] takes less space to print than [m]. Using proportional fonts generally increases the readability of printed documents, giving text a typeset appearance.
<b>font weight</b>	The thickness of the lines making up a character. For example, “ <b>bold</b> ” and “light” are different font weights.
<b>font width</b>	The measurement of the width of a character cell in dots.

## H

<b>hammer</b>	The hammer spring with a hammer tip mounted onto it.
<b>hammer spring</b>	The flat piece of metal, made of spring steel, which supports and pushes the hammer tip.

<b>hammer tip</b>	The small, round point, located near the end of the hammer spring, which strikes the ribbon and leaves a dot on the paper.
<b>hex codes</b>	Based on a numeral system with a radix of 16.
<b>host (computer)</b>	The computer that stores, processes, and sends data to be printed, which communicates directly with the printer. The term “host” specifies the controlling computer, since modern printers are themselves microprocessor–controlled computer systems.
<b>HS</b>	<i>Abbrev. for high speed font. Also referred to as draft.</i>
<b>HT</b>	Horizontal Tab.
<b>Hz</b>	Hertz. Cycles per second, a measure of frequency.

## I

<b>IGP</b>	Intelligent Graphics Processor. An optional emulation that converts graphics commands received from the host computer to binary plot data that is usable by the printer.
<b>initialization</b>	A series of processes and self-tests to set power-up default conditions and parameters.
<b>interface</b>	The hardware component used to link two devices by common physical interconnection, signal, and functional characteristics.
<b>invoke</b>	To put into effect or operation.
<b>IPDS</b>	Intelligent Printer Data Stream.
<b>ipm</b>	<i>Abbrev. for inches per minute. A measurement of the speed of a printer printing in graphics print mode (plotting speed).</i>
<b>italic</b>	A slanted type style. <i>This is an italic type style.</i> Both forward and backward slant are available.

## L

<b>LAC</b>	Load Alternate Characters.
<b>LF</b>	Line Feed.
<b>landscape</b>	Printed perpendicular to the paper motion.

<b>LCD</b>	Liquid-crystal display. The LCD is located on the operator panel. Its purpose is to communicate information to the operator concerning the operating state of the printer.
<b>LED</b>	Light Emitting Diode. The printer operator panel has LEDs that indicate the state of the printer to the operator.
<b>logical link</b>	The parameters that specify data transfer, control, or communication operations.
<b>lpi</b>	<i>Abbrev. for</i> lines per inch. A measurement indicating the vertical spacing between successive lines of text. For example, 8 lpi means eight lines of text for every vertical inch.
<b>lpm</b>	<i>Abbrev. for</i> lines per minute. A measurement of the print speed of a line printer printing in text print mode.

## M

<b>monospaced</b>	<i>See font, monospaced.</i>
<b>MM</b>	Millimeter.
<b>MPL</b>	Maximum Page Length. Also known as forms length. The number of lines that can be printed on a page.
<b>MPP</b>	Maximum Print Position. Also known as line length. ( <i>See also</i> PMPP.)

## N

<b>NAK</b>	Negative acknowledge. Not acknowledged.
<b>N/A</b>	Not available or not applicable.
<b>NL</b>	New Line (3287 only).
<b>NLQ</b>	<i>Abbrev. for</i> near letter quality font. This is the highest resolution mode supported on the 6400.
<b>Not Ready mode</b>	Offline. The printer is not ready to receive and process commands and data.

<b>nS</b>	Nanosecond.
<b>NVFU</b>	Direct Access Vertical Format Unit. <i>See also</i> <b>DAVFU</b> .
<b>NVRAM</b>	<i>Abbrev. for</i> non-volatile random access memory. This storage is permanent, in the sense that information is not lost when the printer is powered off.

## O

<b>OCR</b>	<i>Abbrev. for</i> Optical Character Recognition. A process by which a machine can “read” characters printed in a special standardized font. Data are read by a photoelectric optical scanner and can be recorded on magnetic tape or disk. OCR-A and OCR-B are two widely used OCR fonts.
<b>Ohm</b>	A unit of measurement for electrical resistance.

## P

<b>PA</b>	Program Attention. Used in applications programs.
<b>parity (check)</b>	Parity checking is the addition of non-data bits to data, resulting in the number of bits that are set to a “1” being either always even or always odd. Parity is used to detect data errors.
<b>PC</b>	Personal Computer.
<b>PCBA</b>	Printed Circuit Board Assembly.
<b>pel</b>	The smallest element of a physical medium that can be independently assigned color and intensity. Pels per inch is often used as a measurement of presentation granularity. Synonymous with picture element, pixel.
<b>PI</b>	<i>Abbrev. for</i> Paper Instruction: a physical hardware I/O line used in conjunction with the eight data bit lines. When PI is set high, it indicates that the eight data bits are interpreted as a paper motion command instead of printable data.
<b>pica</b>	A name indicating a monospaced font with a pitch of 10 cpi (and usually 12 points in height). Pica is also used in typography as a unit of measurement equal to 1/6 inch .

<b>pitch</b>	The number of text characters printed per horizontal inch. Specified in characters per inch or cpi.
<b>pixel</b>	Derived from picture (PIX) <i>E</i> LEMENT. The smallest displayable picture element on a video monitor or printable unit. In printing, a pixel is a dot.
<b>PMPP</b>	Physical Maximum Print Position. The longest line the printer is capable of printing. This differs from MPP in that the printer may be capable of printing lines 132 characters wide (PMPP), but the print job is only 80 characters wide (MPP). ( <i>See also</i> MPP.)
<b>point</b>	A unit of length in printing and typography, used to specify type sizes, heights of font characters, etc. There are 72 points in a vertical inch; thus, one point equals 1/72 inch, or approximately 0.0139 inch. Some examples of point sizes are: This is 8 point type. This manual is printed in 11 point type. <b>This is 14 point type.</b>
<b>POR</b>	Power On Reset.
<b>port</b>	A channel used for receiving data from or transmitting data to one or more external devices.
<b>portrait</b>	Printed parallel to the paper motion.
<b>print mode</b>	Font.
<b>proportion, character</b>	<i>See</i> <b>character proportion</b> .
<b>proportional</b>	<i>See</i> <b>font, proportional</b> .
<b>protocol</b>	The rules and conventions that govern communication between a printer and a host computer. A protocol includes codes for printing text and graphics and codes instructing the printer to perform special operations. ( <i>See also</i> compatibility and emulation.)

## R

<b>RAM</b>	Random Access Memory. Can be read from or written to at any time. RAM is volatile: Whatever information is in RAM is lost when power is removed or interrupted.
<b>RD</b>	Receive Data.



<b>read</b>	To retrieve data from memory or from mass storage (hard disk, floppy diskette, etc.).
<b>Ready mode</b>	Online. The printer is ready to receive and process commands and data.
<b>reset</b>	To turn off, deactivate, disable, or return to a previously determined state.
<b>resolution</b>	A measure expressing the number of component units in a given range used to create an image; in printing, expressed as the number of dots per inch (dpi) horizontally and vertically.
<b>ROM</b>	Read Only Memory. Programs, instructions, and routines permanently stored in the printer that cannot be written to. Information in ROM is not lost when power is powered off. (ROM–resident fonts are fonts permanently stored in a printer and available at any time via software commands to the printer.)
<b>Roman</b>	An NLQ type style in which the characters are upright and the edges of the characters have a serif. This sentence is printed in a Roman type style.
<b>RTS</b>	Request To Send.

## S

<b>SA</b>	Set Attribute.
<b>SAA</b>	Systems Application Architecture.
<b>sans serif</b>	An NLQ type style in which the characters are upright and blocked. This sentence is printed in a sans serif type style.
<b>SCS</b>	System Network Architecture (SNA) Character String. Usually commands to set printer format, etc.
<b>serial communications</b>	The sequential transmission of data, in which each element is transferred in succession.
<b>set</b>	To turn on, activate, invoke, or enable.

<b>SFCC sequence</b>	Special Function Control Character sequence. Two or more bytes that describe a specific printer control function. The first byte is always the SFCC. This also applies to IGP options.
<b>shuttle</b>	The subassembly in a line matrix printer that includes the hammer bank assembly, plus some or all of the drive mechanism.
<b>size, type</b>	<i>See point.</i>
<b>SLD</b>	Set Line Density.
<b>slew</b>	Rapid vertical paper movement.
<b>SNA</b>	Systems Network Architecture.
<b>SOH</b>	Start Of Header.
<b>spacing</b>	<i>See font, proportional and font, monospaced.</i>
<b>SSCC</b>	SuperSet Control Character. <i>See escape sequence and command sequence.</i>
<b>start bits</b>	In serial data transfer, a signal indicating the beginning of a character or data element.
<b>stop bits</b>	In serial data transfer, a signal indicating the end of a character or data element.
<b>string</b>	Two or more bytes of data or code treated as a unit.
<b>style, type</b>	<i>See type style.</i>
<b>symbol set</b>	<i>See character set.</i>

## T

<b>TCB</b>	Task Control Block.
<b>TD</b>	Transmit Data.
<b>TOF</b>	Top Of Form.

<b>TTL</b>	Transistor-Transistor Logic.
<b>type family</b>	<i>See</i> <b>typeface</b> .
<b>type size</b>	<i>See</i> <b>point</b> .
<b>type style</b>	Refers to either the upright or italic character style in a specific font family. Roman is upright, <i>italic is slanted</i> .
<b>typeface</b>	A descriptive name or brand name that identifies a particular design of type. Examples are: Courier, Helvetica, and Swiss. Also called type family.
<b>typographic font</b>	<i>See</i> <b>font, proportional</b> .

## U

<b>UPC</b>	Universal Product Code.
<b>USET</b>	<i>Abbrev. for</i> User-defined Set: An IGP command that creates custom character sets (except OCR fonts) from existing characters stored in memory.

## V

<b>VFU</b>	<i>Abbrev. for</i> vertical format unit.
------------	--

## W

<b>warm start</b>	An almost complete reset of the printer: a) Data are cleared from all buffers. b) All internal system variables are reset to default (host set). c) Selected power-up configuration is loaded.
<b>weight</b>	<i>See</i> <b>character weight</b> .
<b>write</b>	To store data to memory (RAM) or to mass storage (hard disk, floppy diskette, etc.).



# Index

## Numbers

- 001 END OF FORMS, 6–15
- 002 FORMS JAMMED, 6–15
- 003 FORMS EJECTED, 6–15
- 004 VIEW FORMS, 6–15
- 006 HOST SYSTEM REQUEST  
ATTENTION, 6–15
- 007 FM HEADER ERROR, 6–15
- 008 HOLD PRINT TIMEOUT, 6–15
- 009 INVALID KEYPRESS, 6–15
- 010 PARAMETER ERROR, 6–15
- 011 SCS COMMAND ERROR, 6–15
- 012 STRUCTURED FIELD ERROR, 6–15
- 013 ACTIVATE LOST, 6–15
- 014 INVALID ACTIVATE, 6–16
- 015 COMMUNICATION CHECK, 6–16
- 016 INVALID COMMAND, 6–16
- 021 RECEIVE BUFFER OVERRUN, 6–16
- 022 UNIT ADDRESS NOT RECEIVED,  
6–16
- 024 SERIAL LINE PARITY ERROR, 6–16
- 025 SERIAL FRAMING ERROR, 6–16
- 026 HEX DUMP MODE, 6–16
- 027 COMMUNICATION CHECK, 6–16
- 028 COMMUNICATION CHECK, 6–16
- 029 8344 DIAGNOSTIC TEST FAILED,  
6–16
- 031 END OF FORMS TIMEOUT, 6–16
- 032 FORMS JAMMED TIMEOUT, 6–17
- 041 BUFFER OVERFLOW, 6–17
- 042 CUSTOM SET DOES NOT EXIST,  
6–17
- 043 CUSTOM SET ALREADY EXISTS,  
6–17
- 044 EC FIRMWARE/HARDWARE ERROR,  
6–17
- 046 EC STOPPED AT STATE, 6–17
- 057 CLOSE PLATEN, 6–17
- 058 SHUTTLE JAM, 6–17
- 059 CANCEL PRINT ACTIVE, 6–17
- 060 PRINTER HOT, 6–17
- 062 EXHAUST FAN FAULT, 6–18
- 063 INTAKE FAN FAULT, 6–18
- 065 HAMMER BANK FAN FAULT, 6–18
- 069 DATA CLEARED, 6–19
- 080 POWER SUPPLY HOT, 6–19
- 082 POWER SUPPLY 8.5V FAILED, 6–19
- 084 POWER SUPPLY 48V FAILED, 6–19
- 085 CONTROLLER VOLTAGE, 6–19
- 086 CONTROLLER 15V, 6–19
- 087 PLATEN OPEN TIMEOUT, 6–19
- 088 CONTROLLER 23.5V, 6–19
- 089 RIBBON STALL, 6–19
- 090 SHUTTLE COVER OPEN, 6–19
- 092 RIBBON DRIVER CIRCUIT, 6–19
- 101 UPPER DRIVER SHORT, 6–19
- 102 LOWER DRIVER SHORT, 6–19
- 107 HAMMER COIL OPEN, 6–20
- 110 STACK OVERFLOW, 6–20
- 111 STACK UNDERFLOW, 6–20
- 112 UNDEFINED OP CODE, 6–20
- 113 PROTECTED INSTRUCTION, 6–20

114 ILLEGAL OPERAND ACCESS, 6–20  
115 ILLEGAL INSTRUCTION ACCESS,  
6–20  
116 ILLEGAL EXTERNAL BUS ACCESS,  
6–20  
117 A TO D OVERRUN, 6–20  
118 UNDEFINED INTERRUPT, 6–20  
119 TCB CORRUPTED, 6–20  
120 ACCESS NULL POINTER, 6–20  
121 PAPER NOT AT SPEED, 6–20  
122 PAPER NOT SCHEDULED, 6–21  
123 PAPER BUSY TOO LONG, 6–21  
124 PAPER FIFO OVERFLOW, 6–21  
125 PAPER FIFO UNDERFLOW, 6–21  
126 PAPER FEED BAD TABLE, 6–21  
127 PAPER FEED ILLEGAL STATE, 6–21  
128 PAPER FEED INVALID COMMAND,  
6–21  
1284 Parallel interface, 5–13  
129 PAPER FEED INVALID PARAMETER,  
6–21  
130 PAPER FEED PARTLY ENERGIZED,  
6–21  
131 PAPER FEED INTERRUPT, 6–21  
132 RIBBON INVALID COMMAND, 6–21  
133 RIBBON INVALID STATE, 6–21  
134 PLATEN INVALID COMMAND, 6–21  
135 PLATEN INVALID STATE, 6–22  
136 PLATEN INVALID PARAMETER,  
6–22  
137 SHUTTLE INVALID COMMAND,  
6–22  
138 SHUTTLE INVALID PARAMETER,  
6–22

139 SHUTTLE OVERSPEED, 6–22  
11 inch pages, 4–82  
20 CPI condensed parameter  
Epson emulation, 4–57  
Proprinter III XL emulation, 4–54  
990 MACHINE CHECK, 6–22  
998 NON-VOLATILE MEMORY FAILED,  
6–22

## A

A to D, definition, Glossary–1  
A97 GRAPHIC CHECK ERROR, 6–22  
ACK, definition, Glossary–1  
ACK/NAK protocol  
RS–232 serial interface, 5–5  
RS–422 serial interface, 5–5  
Acknowledge signal, PC parallel interface,  
5–8  
Acoustic Noise Level, A–5  
Active column, definition, Glossary–1  
Active line, definition, Glossary–1  
Active position, definition, Glossary–1  
Active print language parameter  
coax interface, 4–28  
twinax interface, 4–21  
Adjust Ribbon, 7–6  
Alarm control parameter, 4–11  
Alignment, horizontal, 2–41  
All E's + FF test, 4–81, 6–7  
All E's test, 4–81, 6–7  
All H's test, 4–81, 6–7  
Alternate character set parameter, Proprinter  
III XL emulation, 4–53  
Alternate set 80–9F parameter  
P-Series emulation, 4–63

Serial Matrix emulation, 4-72

ASCII, definition, Glossary-1

ASCII printer emulation parameter, 4-50

Attaching operator panel overlay label, 2-27

Attachment switching, 4-11

Attributes, print, definition, Glossary-1

Auto LF parameter

- Epson emulation, 4-56
- P-Series emulation, 4-61
- Proprinter III XL emulation, 4-53
- P-Series XQ emulation, 4-65
- Serial Matrix emulation, 4-71

Auto skip at end, 4-35

## B

Bar code, definition, Glossary-1

Baud, definition, Glossary-1

Baud rate parameter, 4-45

Bidirectional printing, 4-11

Bold, definition, Glossary-2

Bottom Margin, compatibility option, 4-36

Buffer, definition, Glossary-2

Buffer Reprint, 4-29

Buffer size in kilobytes parameter

- PC parallel, 4-40
- serial interface, 4-47

Bus, definition, Glossary-2

Busy on strobe parameter, 4-39

Busy signal, PC parallel interface, 5-8

Byte mode, 5-14

## C

Cable connections

- cabinet models, 2-23
- pedestal models, 2-25

Cable requirements, A-9

Cable verify signal, Dataproducts parallel interface, 5-11

Cancel buffers parameter

- coax interface, 4-30
- twinax interface, 4-22

Caution notice description, 1-2

Change power on set parameter, 4-18

Changing parameters, 3-18

Character cell, definition, Glossary-2

Character Filtering, D-10

Character formation, B-2

Character proportion, definition, Glossary-2

Character set, definition, Glossary-2

Character sets emulation, Epson emulation, 4-56

Character sets parameter

- P-Series emulation, 4-60
- Serial Matrix emulation, 4-70

Character sets, printing

- coax interface, 4-28
- twinax interface, 4-21

Character weight, definition, Glossary-2

Characters per inch parameter, 4-74

Checksum, definition, Glossary-2

Cleaning requirements, 6-2

Clear to send (CTS) signal, RS-232 serial interface, 5-4

Coax interface menu, 4-26

- active print language, 4-28
- Buffer Reprint, 4-29

- cancel buffers, 4–30
- early print complete, 4–29
- format control, 4–32
- hex print mode, 4–32
- hex transparent control, 4–30
- image buffer size, 4–31
- intervention required, 4–31
- mono/dual case, 4–30
- override host, 4–32
- PA1, 4–28
- PA2, 4–29
- print character table, 4–28
- print language, 4–28
- print text direction, 4–31
- printer emulation, 4–29
- translate table, 4–31
- Code V, definition, Glossary–2
- Code V configuration menu, D–5
  - absorb at ^PY, D–8
  - append rotated, D–7
  - bar code errors, D–10
  - data bit 8, D–11
  - error markers, D–10
  - error messages, D–10
  - font set, D–12
  - host PI, D–12
  - ignore characters, D–10
  - ignore dots value, D–7
  - ignore spaces, D–9
  - IGP 110 compatibility, D–9
  - lines per inch, D–7
  - midline PY, D–9
  - off page errors, D–10
  - PI slew range, D–12
  - power on ^F, D–6
  - power on ^PY, D–6
  - power on ^X, D–6
  - printer PI, D–12
  - rotate character size, D–8
  - select character 1, D–11
  - select character 2, D–11
  - select SFCC, D–6
  - slashed zero, D–7
  - true vert 1/10, D–8
  - truncate off page alpha, D–7
  - UPC descenders, D–8
  - width limit, D–9
- Code V configuration menus, barcodes, D–9
- Code V feature
  - configuration, D–4
  - parameters, D–4
- Code V feature (IGP/VGL), D–4
- Command, definition, Glossary–2
- Command delimiter, definition, Glossary–3
- Command sequence, definition, Glossary–3
- Communication notices
  - Canada, xi
  - United Kingdom, xi
- Communication, bidirectional (1284), 5–13
- Compatibility, definition, Glossary–3
- Compatibility mode, 5–13
- Compatibility options menu, 4–33
  - option 1: CR at MPP+1, 4–34
  - option 2: NL at MPP+1, 4–34
  - option 3: position after FF, 4–34
  - option 4: FF at end, 4–34
  - option 5: null suppression, 4–35
  - option 6: FF command position, 4–35
  - option 7: auto skip at end, 4–35
  - option 8: FF after OIC, 4–36
  - option 9: CR, EM, and NL, 4–36
  - option 10: bottom margin, 4–36
- Component locations, 2–8
- Compressed, definition, Glossary–3



- Compressed print parameter, P-Series XQ emulation, 4–66
- Configuration
  - active versus saved configurations, 3–3
  - changing parameters, 3–18
  - changing power-on configuration, 3–25
  - custom/preloaded sets, 3–9, 4–17
  - Dataproducs parallel interface, 5–12
  - definition, Glossary–3
  - factory default values, 3–11
  - loading custom sets or factory default values, 3–23
  - menu, D–14, D–21
  - PC parallel interface, 5–9
  - printout, 3–8
  - RibbonMinder, 7–3
  - RS–232 serial interface, 5–6
  - RS–422 serial interface, 5–6
  - saving a new configuration, 3–20
  - terminating resistors, 5–17
- Configuration management menu, 4–16
  - change power on set, 4–18
  - delete custom set, 4–18
  - print custom set values, 4–18
  - protect custom sets, 4–18
  - recall custom set, 4–17
  - save current values, 4–18
- Configuration menus, 4–1
  - coax interface, 4–26
    - coax print language, 4–27
  - compatibility options, 4–33
  - configuration management, 4–16
  - Dataproducs, 4–41
  - emulation configuration, 4–49
  - Epson emulation, 4–55
  - how to read, 4–7
  - main, 3–5, 4–9
  - operator print tests, 4–81
  - overview, 4–7
  - P-Series emulation, 4–58
  - P-Series print language, 4–59
  - parallel interface, 4–37
  - PC parallel, 4–38
  - print format, 4–73
  - printer control, 4–10
  - printer information, 4–82
  - Proprinter III XL emulation, 4–52
  - P-Series XQ emulation, 4–64
  - serial interface, 4–44
  - Serial Matrix emulation, 4–68
  - Serial Matrix print language, 4–69
  - twinx interface, 4–19
    - twinx print language, 4–20
- Configurations, types of, 3–2
- Configuring the printer, overview, 3–2
- Connections, cable
  - cabinet models, 2–23
  - pedestal models, 2–25
- Control code 06 parameter
  - P-Series emulation, 4–61
  - P-Series XQ emulation, 4–65
  - Serial Matrix emulation, 4–71
- Control code 08 parameter, P-Series emulation, 4–61
- Control codes, overview description, 1–13
- Control panel overlay label. *See* Operator panel overlay label
- Controller, definition, Glossary–3
- CPI, definition, Glossary–3
- CPS, definition, Glossary–3
- CPU, definition, Glossary–3
- CR, definition, Glossary–3
- CR at MPP+1, 4–34
- CR, EM, and NL, 4–36

CT0, definition, Glossary–3  
CTA, definition, Glossary–3  
CTS, definition, Glossary–4  
Custom sets, 4–16  
Custom sets or factory default values,  
loading, 3–23  
Custom/preloaded sets, 3–9, 4–17  
CVFU, definition, Glossary–4

## D

Danger notice description, 1–2  
Data bit 8 parameter  
Dataproducts, 4–42  
PC parallel, 4–39  
Data bits parameter, 4–46  
Data carrier detect (DCD) signal, RS–232  
serial interface, 5–4  
Data lines 1 through 8 signal  
Dataproducts parallel interface, 5–11  
PC parallel interface, 5–8  
Data polarity parameter  
Dataproducts, 4–42  
PC parallel, 4–39  
Data protocol parameter, serial interface,  
4–45  
Data request polarity parameter, 4–42  
Data set ready (DSR) signal, RS–232 serial  
interface, 5–4  
Data strobe signal  
Dataproducts parallel interface, 5–11  
PC parallel interface, 5–8  
Data terminal ready (DTR) signal, RS–232  
serial interface, 5–4  
Data terminal ready parameter, 4–46

Dataproducts menu, 4–41  
data bit 8, 4–42  
data polarity, 4–42  
data request polarity, 4–42  
PI ignored, 4–42  
strobe polarity, 4–42  
Dataproducts parallel interface, 5–10  
configuration, 5–12  
pin assignments, 5–10  
signals, 5–11  
DAVFU, definition, Glossary–4  
DC, definition, Glossary–4  
DCD, definition, Glossary–4  
Decipoint, definition, Glossary–4  
Default, definition, Glossary–4  
Default configuration parameters, 3–11  
Define CR code parameter  
Epson emulation, 4–56  
P-Series emulation, 4–61  
Proprinter III XL emulation, 4–53  
P-Series XQ emulation, 4–65  
Serial Matrix emulation, 4–71  
Define LF code parameter  
Epson emulation, 4–57  
Proprinter III XL emulation, 4–54  
P-Series emulation, 4–62  
P-Series XQ emulation, 4–65  
Serial Matrix emulation, 4–72  
Delete custom set parameter, 4–18  
Demand/data request signal, Dataproducts  
parallel interface, 5–11  
Descender, definition, Glossary–4  
Diagnostic, definition, Glossary–4  
Diagnostic capabilities, 1–10  
Diagnostic tests, 6–7  
Diagnostics, 6–1

- Dimensions, 6400 printer, A-4
  - cabinet models, 2-6
  - pedestal models, 2-7
- Direction, printing, 4-11
- Disable, definition, Glossary-4
- Display language parameter, 4-11
- Display/Disable RibbonMinder, 4-84
- Distance, maximum allowed from host,
  - printer installation, 2-5
- Dot matrix character formation, example,
  - B-2
- DP, definition, Glossary-4
- Draft, definition, Glossary-4
- DRAM, definition, Glossary-4
- DSR, definition, Glossary-4
- DTR, definition, Glossary-4
- DTR protocol
  - RS-232 serial interface, 5-5
  - RS-422 serial interface, 5-5
- DVFU, definition, Glossary-4

## E

- Early print complete parameter
  - coax interface, 4-29
  - twinax interface, 4-22
- EBCDIC, definition, Glossary-5
- EC, definition, Glossary-5
- ECMA, definition, Glossary-5
- EIA, definition, Glossary-5
- Eject/Restore parameter, 4-14
- Electrical characteristics, A-6
- Elite, definition, Glossary-5
- Elong/alt. font parameter, P-Series XQ
  - emulation, 4-66

- EM, definition, Glossary-5
- Em, definition, Glossary-5
- Emulation, definition, Glossary-5
- Emulation configuration menu, 4-49
  - ASCII printer emulation, 4-50
  - print format, 4-51
  - printer emulation configuration, 4-51
- Emulations, 1-7
  - overview definition, 1-13
- En, definition, Glossary-5
- Enable, definition, Glossary-5
- ENERGY SAVER MODE ACTIVE, 6-22
- Energy saver timer parameter, 4-13
- Entering program mode, 3-7
- Environmental characteristics, A-5
- Epson emulation menu, 4-55
  - 20 CPI condensed, 4-57
  - auto LF, 4-56
  - character sets, 4-56
  - define CR code, 4-56
  - define LF code, 4-57
  - print language, 4-56
  - printer select, 4-57
- Epson FX Printer Emulation, 1-8
- Error Handling, D-10
- Error handling
  - RS-232 serial interface, 5-5
  - RS-422 serial interface, 5-5
- Error messages, 6-14
- Escape sequence, definition, Glossary-5
- ETX, definition, Glossary-5
- ETX/ACK protocol
  - RS-232 serial interface, 5-5
  - RS-422 serial interface, 5-5
- EVFU, definition, Glossary-5

EVFU select parameter  
P-Series emulation, 4–62  
P-Series XQ emulation, 4–66  
Expanded, definition, Glossary–5

## F

Factory default parameters, 3–11  
Family, definition, Glossary–5  
Fault Action, 4–84  
RibbonMinder, 7–7  
Fault correction procedure, 6–14  
Fault messages, 6–14, 6–15  
RibbonMinder, 7–5  
Features  
optional, 1–11  
standard, 1–7  
FF, definition, Glossary–5  
FF after OIC, 4–36  
FF at end, 4–34  
FF command position, 4–35  
FF valid at TOF parameter, Proprinter III XL  
emulation, 4–54  
FIFO, definition, Glossary–6  
Fixed-pitch fonts, definition, Glossary–6  
FM Header, definition, Glossary–6  
Font, definition, Glossary–6  
Font name, definition, Glossary–6  
Font pattern, definition, Glossary–6  
Font weight, definition, Glossary–6  
Font width, definition, Glossary–6  
Font, monospaced, definition, Glossary–6  
Font, proportional, definition, Glossary–6  
Format control parameter  
coax interface, 4–32

twinax interface, 4–25  
Format conventions, 1–3  
Forms length parameter, 4–77  
Forms speed parameter, 4–12  
Forms width parameter, 4–75  
Framing error handling, 5–5

## G

Glossary, Glossary–1  
Graphics and vertical formatting features, 1–9  
Graphics features  
Epson dot graphics mode, 1–9  
IBM bit-image graphics, 1–9  
IBM, Epson and P-Series graphics  
generators, 1–9  
P-Series plot, 1–9  
Graphics Options, D–7

## H

Hammer, definition, Glossary–6  
Hammer Coil Bad, 6–22  
Hammer spring, definition, Glossary–6  
Hammer tip, definition, Glossary–7  
Handshaking, IEEE 1284 interface, 5–14  
Hex code printout, 6–10  
ASCII sample, 6–12  
coax sample, 6–13  
twinax sample, 6–13  
Hex codes, definition, Glossary–7  
Hex print mode parameter, 4–12  
coax interface, 4–32  
twinax interface, 4–25  
Hex transparent control parameter  
coax interface, 4–30  
twinax interface, 4–23

High speed print mode parameter, P-Series  
XQ emulation, 4–66

Horizontal adjustment knob, 2–41

Host (computer), definition, Glossary–7

Host attachment, C–2  
compatibility, C–5  
limitations, C–6  
operating systems supported, C–3

Host computer interfaces, 1–7

Host interface cable connectors  
cabinet models, 2–24  
pedestal models, 2–26

HS, definition, Glossary–7

HT, definition, Glossary–7

Humidity requirements, 2–5, A–5

Hz, definition, Glossary–7

## I

IEEE 1284 interface, 5–13  
operating modes, 5–13  
pinout signals, 5–16  
printer pinout signals, 5–15  
signals, 5–14

IGP, definition, Glossary–7

IGP configuration menu, D–14  
auto LF, D–15  
compressed 17 CPI, D–18  
CR edit, D–16  
define CR code, D–15  
define LF code, D–15  
expanded font, D–9, D–19  
extended execute copy, D–18  
ignore character, D–18  
IGP 100 compatibility, D–19  
lines per inch, D–17

mono/dual case, D–17  
optimized ratio, D–19  
PI slew range, D–16  
power on IGP, D–17  
select font, D–16  
select SFCC, D–15  
skip command prefix, D–17  
UPC descenders, D–18

IGP Feature, (IGP/PGL), D–13

IGP feature  
configuration, D–13  
parameters, D–13

IGP/PGL, D–13

IGP/VGL, D–4

Image buffer size parameter, 4–31

Important notice description, 1–2

Indicator LED, format conventions, 1–3

Initialization, definition, Glossary–7

Installation  
cable connections  
cabinet models, 2–23  
pedestal models, 2–25  
new ribbon, 4–83, 7–5  
removing packing materials, 2–12  
shipping restraints removal  
cabinet models, 2–12  
pedestal models, 2–18  
site requirements, 2–5

Installed memory, 4–82

Installing ribbon, 2–28

Installing the printer, 2–1

Interface  
Dataproducts parallel, 5–10  
definition, 5–2, Glossary–7  
PC parallel, 5–7  
RS–232 serial, 5–3

- RS-422 serial, 5-3
- Interface selection parameter, 4-11
- Interface specifications, A-8
- Interface type parameter
  - parallel interface, 4-37
  - serial interface, 4-45
- Interfaces
  - IEEE 1284, 5-13
  - printer, 5-1
- Intervention required parameter, 4-31
- Introduction to this manual, 1-1
- Invoke, definition, Glossary-7
- IPDS, definition, Glossary-7
- IPDS configuration menu, D-21
  - bar code quality, D-23
  - early print complete, D-22
  - graphics quality, D-23
  - image quality, D-23
  - IPDS emulation mode, D-24
  - override host, D-22
- IPDS feature, D-20
  - configuration, D-20
- IPM, definition, Glossary-7
- Italic, definition, Glossary-7

## K

- Keys, format conventions, 1-3
- Keys and indicators, 3-6

## L

- Label, operator panel overlay, attaching, 2-27
- Labels, specifications, A-3
- LAC, definition, Glossary-7
- Landscape, definition, Glossary-7

- Latch data on parameter, 4-40
- LCD, definition, Glossary-8
- LED, definition, Glossary-8
- LF, definition, Glossary-7
- Line matrix printing
  - character formation, B-2
  - example, B-3
  - theory, B-1
  - vs. serial matrix printing, B-1
- Lines per inch parameter, 4-74
- Load alternate character parameter, 4-24
- Loading emulations, 4-50
- Loading paper, 2-35
- Locking program mode, 3-7
- Logical link, definition, Glossary-8
- LPI, definition, Glossary-8
- LPM, definition, Glossary-8

## M

- Maintenance, 6-2
- Manuals, related to 6400, 1-3
- Margins parameter, 4-79
- Matrix printing, line matrix vs. serial matrix, B-1
- Maximum print speed, 1-7
- Memory, installed, 4-82
- Menu, configuration, D-14, D-21
  - RibbonMinder, 4-83
- Messages
  - 001 END OF FORMS, 6-15
  - 002 FORMS JAMMED, 6-15
  - 003 FORMS EJECTED, 6-15
  - 004 VIEW FORMS, 6-15
  - 006 HOST SYSTEM REQUEST ATTENTION, 6-15

007 FM HEADER ERROR, 6-15  
 008 HOLD PRINT TIMEOUT, 6-15  
 009 INVALID KEYPRESS, 6-15  
 010 PARAMETER ERROR, 6-15  
 011 SCS COMMAND ERROR, 6-15  
 012 STRUCTURED FIELD ERROR,  
     6-15  
 013 ACTIVATE LOST, 6-15  
 014 INVALID ACTIVATE, 6-16  
 015 COMMUNICATION CHECK, 6-16  
 016 INVALID COMMAND, 6-16  
 021 RECEIVE BUFFER OVERRUN,  
     6-16  
 022 UNIT ADDRESS NOT RECEIVED,  
     6-16  
 024 SERIAL LINE PARITY ERROR,  
     6-16  
 025 SERIAL FRAMING ERROR, 6-16  
 026 HEX DUMP MODE, 6-16  
 027 COMMUNICATION CHECK, 6-16  
 028 COMMUNICATION CHECK, 6-16  
 029 8344 DIAGNOSTIC TEST FAILED,  
     6-16  
 031 END OF FORMS TIMEOUT, 6-16  
 032 FORMS JAMMED TIMEOUT, 6-17  
 041 BUFFER OVERFLOW, 6-17  
 042 CUSTOM SET DOWN NOT EXIST,  
     6-17  
 043 CUSTOM SET ALREADY EXISTS,  
     6-17  
 044 EC FIRMWARE/HARDWARE  
     ERROR, 6-17  
 046 EC STOPPED AT STATE, 6-17  
 057 CLOSE PLATEN, 6-17  
 058 SHUTTLE JAM, 6-17  
 059 CANCEL PRINT ACTIVE, 6-17  
 060 PRINTER HOT, 6-17  
 062 EXHAUST FAN FAULT, 6-18  
 063 INTAKE FAN FAULT, 6-18  
 065 HAMMER BANK FAN FAILURE,  
     6-18  
 069 DATA CLEARED, 6-19  
 080 POWER SUPPLY HOT, 6-19  
 082 POWER SUPPLY 8.5V FAILED,  
     6-19  
 084 POWER SUPPLY 48V FAILED, 6-19  
 085 CONTROLLER VOLTAGE, 6-19  
 086 CONTROLLER 15V, 6-19  
 087 PLATEN OPEN TIMEOUT, 6-19  
 088 CONTROLLER 23.5V, 6-19  
 089 RIBBON STALL, 6-19  
 090 SHUTTLE COVER OPEN, 6-19  
 092 RIBBON DRIVER CIRCUIT, 6-19  
 101 UPPER DRIVER SHORT, 6-19  
 102 LOWER DRIVER SHORT, 6-19  
 107 HAMMER COIL HOT, 6-20  
 110 STACK OVERFLOW, 6-20  
 111 STACK UNDERFLOW, 6-20  
 112 UNDEFINED OP CODE, 6-20  
 113 PROTECTED INSTRUCTION, 6-20  
 114 ILLEGAL OPERAND ACCESS, 6-20  
 115 ILLEGAL INSTRUCTION ACCESS,  
     6-20  
 116 ILLEGAL EXTERNAL BUS  
     ACCESS, 6-20  
 117 A TO D OVERRUN, 6-20  
 118 UNDEFINED INTERRUPT, 6-20  
 119 TCB CORRUPTED, 6-20  
 120 ACCESS NULL POINTER, 6-20  
 121 PAPER NOT AT SPEED, 6-20  
 122 PAPER NOT SCHEDULED, 6-21  
 123 PAPER BUSY TOO LONG, 6-21  
 124 PAPER FIFO OVERFLOW, 6-21  
 125 PAPER FIFO UNDERFLOW, 6-21  
 126 PAPER FEED BAD TABLE, 6-21  
 127 PAPER FEED ILLEGAL STATE,  
     6-21



128 PAPER FEED INVALID  
     COMMAND, 6–21  
 129 PAPER FEED INVALID  
     PARAMETER, 6–21  
 130 PAPER FEED PARTLY  
     ENERGIZED, 6–21  
 131 PAPER FEED INTERRUPT, 6–21  
 132 RIBBON INVALID COMMAND,  
     6–21  
 133 RIBBON INVALID STATE, 6–21  
 134 PLATEN INVALID COMMAND,  
     6–21  
 135 PLATEN INVALID STATE, 6–22  
 136 PLATEN INVALID PARAMETER,  
     6–22  
 137 SHUTTLE INVALID COMMAND,  
     6–22  
 138 SHUTTLE INVALID PARAMETER,  
     6–22  
 139 SHUTTLE OVERSPEED, 6–22  
 990 MACHINE CHECK, 6–22  
 998 NON-VOLATILE MEMORY  
     FAILED, 6–22  
 A97 GRAPHIC CHECK ERROR, 6–22  
 ENERGY SAVER MODE ACTIVE, 6–22  
 Hammer Coil Bad, 6–22  
 NOT READY, 6–22  
 OPERATOR MENU, 6–22  
 OPERATOR MENU LOCKED, 6–22  
 OPERATOR MENU UNLOCKED, 6–22  
 P05 DIAGNOSTIC TEST PASSED, 6–23  
 P17 SECURITY VIOLATION, 6–23  
 PA1, 6–23  
 PA2, 6–23  
 PLEASE WAIT... RESET IN PROGRESS,  
     6–23  
 READY, 6–23  
 Ribbon Ink Out, 6–23

SERVICE MENU, 6–23  
 TESTING HARDWARE / PLEASE WAIT,  
     6–23  
 TOP OF FORM SET, 6–23

Messages, fault, 6–14  
 MM, definition, Glossary–8  
 Mono/dual case parameter, 4–30  
 Monospaced, definition, Glossary–8  
 MPL, definition, Glossary–8  
 MPP, definition, Glossary–8

## N

N/A, definition, Glossary–8  
 NAK, definition, Glossary–8  
 Negotiation phase, 5–14  
 New ribbon  
     installing, 7–5  
     parameter, 7–5  
 Nibble mode, 5–13  
 NL, definition, Glossary–8  
 NL at MPP+1, 4–34  
 NLQ, definition, Glossary–8  
 NOT READY, 6–22  
 Not Ready mode, definition, Glossary–8  
 Note description, 1–2  
 nS, definition, Glossary–9  
 Null suppression, 4–35  
 NVFU, definition, Glossary–9  
 NVRAM, definition, Glossary–9

## O

OCR, definition, Glossary–9  
 OCR B Font Density Parameter, 4–14  
 Ohm, definition, Glossary–9



- One char enquiry, serial interface, 4–48
- Online signal, Dataproducts parallel interface, 5–11
- Online/select signal, PC parallel interface, 5–8
- Operating state at power on, configuring, 4–12
- Operating systems supported, C–3
- OPERATOR MENU, 6–22
- OPERATOR MENU LOCKED, 6–22
- OPERATOR MENU UNLOCKED, 6–22
- Operator panel, 3–6
- Operator panel overlay label, attaching, 2–27
- Operator print tests menu, 4–81
  - all E's, 4–81
  - all E's + FF, 4–81
  - all H's, 4–81
  - print error log, 4–81
  - printer demonstration, 4–81
  - ripple print, 4–81
  - underlines, 4–81
- Optional emulations, loading, 4–50
- Output control features, 1–9
  - automatic underlining and overscoring, 1–9
  - data processing printing mode, 1–9
  - double high and wide printing, 1–9
  - draft printing mode, 1–9
  - emphasized printing, 1–9
  - near-letter quality printing mode, 1–9
  - near-letter quality sans serif printing mode, 1–9
  - OCR A printing mode, 1–9
  - OCR B printing mode, 1–9
  - resident multinational character sets, 1–9
  - selectable forms length and width, 1–9
  - selectable pitch, 1–9
  - super and subscript printing, 1–9
- Overlay label, operator panel, attaching, 2–27
- Override host parameter
  - coax interface, 4–32
  - twinax interface, 4–24
- Overrun error handling, 5–6
- Overstrike parameter
  - P-Series emulation, 4–62
  - Serial Matrix emulation, 4–71
- Overwriting an existing custom set, 4–18

## P

- P05 DIAGNOSTIC TEST PASSED, 6–23
- P17 SECURITY VIOLATION, 6–23
- PA, definition, Glossary–9
- PA1, 6–23
- PA1 parameter, 4–28
- PA2, 6–23
- PA2 parameter, 4–29
- Paper
  - alignment, 2–38
  - specifications, A–3
- Paper empty (PE) signal, PC parallel interface, 5–8
- Paper guide assembly, 2–44, 2–45
- Paper instruction (PI) signal
  - Dataproducts parallel interface, 5–11
  - PC parallel interface, 5–8
- Paper jam detection parameter, 4–12
- Paper loading, 2–35
  - adjusting tractor doors, 2–39
  - align with horizontal adjustment knob, 2–41
  - aligning and feeding paper, 2–38
  - checking the paper feed, 2–44, 2–45

- setting top-of-form, 2–47
- Paper scale, 2–41
- Paper slot location, 2–38
- Paper supply, placement in printer cabinet, 2–38
- Parallel interface
  - Dataproducts, 5–10
  - PC parallel, 5–7
- Parallel interface menu, 4–37
  - Dataproducts, 4–41
  - interface type, 4–37
  - PC parallel, 4–38
- Parameters
  - printing the configuration, 3–8
  - saving, 3–20
- Parameters, changing, 3–18
- Parity (check), definition, Glossary–9
- Parity error handling, 5–5
- Parity parameter, 4–46
- PC, definition, Glossary–9
- PC parallel interface, 5–7
  - configuration, 5–9
- PC parallel interface signals, 5–8
  - acknowledge, 5–8
  - busy, 5–8
  - data lines 1 through 8, 5–8
  - data strobe, 5–8
  - online/select, 5–8
  - paper empty, 5–8
  - paper instruction (PI), 5–8
- PC parallel interface, Printer, pin assignments, 5–7
- PC parallel menu, 4–38
  - buffer size in kilobytes, 4–40
  - busy on strobe, 4–39
  - data bit 8, 4–39
  - data polarity, 4–39
  - latch data on, 4–40
  - prime signal, 4–40
  - response polarity, 4–39
  - strobe polarity, 4–39
  - TOF action at prime signal, 4–40
- PCBA, definition, Glossary–9
- Pel, definition, Glossary–9
- Perforation skip parameter, 4–80
- PI, definition, Glossary–9
- PI Control, D–12
- PI ignored parameter, 4–42
- Pica, definition, Glossary–9
- Pin assignments
  - Dataproducts parallel interface, 5–10
  - Printer PC parallel interface, 5–7
  - RS–232 serial interface, 5–3
  - RS–422 serial interface, 5–3
- Pinout signals, IEEE 1284 interface, 5–16
- Pinout signals, printer, IEEE 1284 interface, 5–15
- Pitch, definition, Glossary–10
- Pixel, definition, Glossary–10
- Platen open fault, 2–42
- PLEASE WAIT... RESET IN PROGRESS (message), 6–23
- Plot rates, B–4
- PMPP, definition, Glossary–10
- Point, definition, Glossary–10
- Poll character, serial interface, 4–47
- POR, definition, Glossary–10
- Port, definition, Glossary–10
- Portrait, definition, Glossary–10
- Position after FF, 4–34

- Power
  - input voltage, A-6
  - power consumption, A-6
- Power on state parameter, 4-12
- Power switch, location, 2-43
- Power-on configuration, changing, 3-25
- Power-on time, 4-82
- Powering printer on, 2-43
- Predefined configurations, 3-2
- Preloaded sets, 3-9, 4-17
- Prime signal parameter, 4-40
- Print attributes, definition, Glossary-1
- Print attributes parameter, 4-79
- Print character table parameter
  - coax interface, 4-28
  - print format, 4-78
  - twinax interface, 4-21
- Print custom set values parameter, 4-18
- Print direction parameter, 4-11
- Print error log test, 4-81, 6-7
- Print format menu, 4-73
  - characters per inch, 4-74
  - forms length, 4-77
  - forms width, 4-75
  - lines per inch, 4-74
  - margins, 4-79
  - perforation skip, 4-80
  - print attributes, 4-79
  - print character table, 4-78
  - print quality, 4-78
  - reset command, 4-80
- Print format parameter, 4-51
- Print language menu, Epson emulation, 4-56
- Print language parameter
  - coax interface, 4-28
  - P-Series emulation, 4-60
  - Proprinter III XL emulation, 4-53
  - Serial Matrix emulation, 4-70
  - twinax interface, 4-21
- Print mode, definition, Glossary-10
- Print quality parameter, 4-78
- Print rates chart, A-10
- Print strokes, 4-82
- Print text direction parameter
  - coax interface, 4-31
  - twinax interface, 4-24
- Printer
  - configuration menus, 4-1
  - dimensions, A-4
  - humidity requirements, 2-5
  - maintenance, 6-2
  - running self-tests, 6-8
  - specifications, A-1
  - temperature requirements, 2-5
  - tests, after installation, 2-50
  - weight, A-4
- Printer address parameter, 4-22
- Printer control menu, 4-10
  - alarm control, 4-11
  - display language, 4-11
  - Eject/Restore, 4-14
  - energy saver timer, 4-13
  - forms speed, 4-12
  - hex print mode, 4-12
  - interface selection, 4-11
  - OCR font density, 4-14
  - paper jam detection, 4-12
  - power on state, 4-12
  - print direction, 4-11
  - set platen at bottom of form, 4-13
  - shuttle timeout, 4-13
- Printer demonstration test, 4-81, 6-7

- Printer emulation configuration parameter, 4–51
  - Epson emulation, 4–51
  - P-Series emulation, 4–51
  - Proprinter III XL emulation, 4–51
  - P-Series XQ emulation, 4–51
  - Serial Matrix emulation, 4–51
- Printer emulation parameter
  - coax interface, 4–29
  - twinax interface, 4–21
- Printer emulations, 1–7
- Printer information menu, 4–82
  - 11 inch pages, 4–82
  - installed memory, 4–82
  - power-on time, 4–82
  - print strokes, 4–82
  - printing time, 4–82
- Printer installation, 2–1
  - maximum distance allowed from host, 2–5
- Printer interfaces, 5–1
- Printer select parameter
  - Epson emulation, 4–57
  - Serial Matrix emulation, 4–72
- Printer self-tests, 6–7
  - all E's, 6–7
  - all E's + FF, 6–7
  - all H's, 6–7
  - print error log, 6–7
  - printer demonstration, 6–7
  - ripple print, 6–7
  - underlines, 6–7
- Printing
  - line matrix vs. serial matrix, B–1
  - number of pages per ribbon, 4–84
  - speed, B–4
- Printing time, 4–82
- Printout, generating hex dump, 4–12
- Printouts, configuration, 3–8
- Printronix P-Series Printer Emulation, 1–8
- Printronix P-Series XQ Variant Printer Emulation, 1–8
- Printronix Serial Matrix Printer Emulation, 1–8
- Product overview, the 6400 printer, 1–5
- Program mode
  - defined, 3–7
  - entering, 3–7
  - locking, 3–7
  - unlocking, 3–7
- Proportion, character, definition, Glossary–10
- Proportional, definition, Glossary–10
- Proprinter III XL emulation menu, 4–52
  - 20 CPI condensed, 4–54
  - alternate character set, 4–53
  - auto LF, 4–53
  - define CR code, 4–53
  - define LF code, 4–54
  - FF valid at TOF, 4–54
  - print language, 4–53
- Proprinter III XL Printer Emulation, 1–8
- Protect custom sets parameter, 4–18
- Protocol, definition, Glossary–10
- Protocols
  - overview definition, 1–13
  - RS–232 serial interface, 5–5
  - RS–422 serial interface, 5–5
- P-Series emulation menu, 4–58
  - alternate set 80–9F, 4–63
  - auto LF, 4–61
  - character sets, 4–60
  - control code 06, 4–61
  - control code 08, 4–61

- define CR code, 4–61
- define LF code, 4–62
- EVFU select, 4–62
- overstrike, 4–62
- print language, 4–59
- select SFCC, 4–62

P-Series XQ emulation menu, 4–64

- auto LF, 4–65
- compressed print, 4–66
- control code 06, 4–65
- define CR code, 4–65
- define LF code, 4–65
- elong/alt. font, 4–66
- EVFU select, 4–66
- high speed print mode, 4–66
- slew relative, 4–67
- upper case select, 4–67

## R

RAM, definition, Glossary–10

Rates, printing and plotting, B–4

RD, definition, Glossary–10

Read, definition, Glossary–11

READY, 6–23

Ready mode, definition, Glossary–11

Ready signal, Dataproducts parallel interface, 5–11

Recall custom set parameter, 4–17

Received data (RD) signal

- RS–232 serial interface, 5–4
- RS–422 serial interface, 5–4

Reference documents, 1–3

Request to send (RTS) signal, RS–232 serial interface, 5–4

Request to send parameter, 4–47

Reset, definition, Glossary–11

Reset command parameter, 4–80

Resetting RibbonMinder, 4–83

Resistors, configuration, 5–17

Resolution, definition, Glossary–11

Response polarity parameter, 4–39

Ribbon

- configuration menu, 4–83
- setting size, 7–6
- size parameter, 4–84
- specifications, A–2

Ribbon Ink Out, 6–23

Ribbon installation, 2–28

Ribbon mask, 2–39

Ribbon path diagram, 2–39

RibbonMinder, 7–2

- configuring, 7–3
- display/disable, 7–5
- fault action, 4–84, 7–7
- fault message, 4–84, 7–5
- new ribbon, 4–83, 7–5
- ribbon action, 4–84, 7–5
- ribbon adjust, 4–84, 7–6
- ribbon size, 4–84
- running a job, 7–5
- set ribbon size, 7–6

Ripple print test, 4–81, 6–7

ROM, definition, Glossary–11

Roman, definition, Glossary–11

Routine service and diagnostics, 6–1

RS–232 serial interface, 5–3

- ACK/NAK protocol, 5–5
- clear to send (CTS), 5–4
- configuration, 5–6
- data carrier detect (DCD), 5–4
- data set ready (DSR), 5–4

- DTR protocol, 5–5
- error handling, 5–5
- ETX/ACK protocol, 5–5
- framing error handling, 5–5
- overflow error handling, 5–6
- parity error handling, 5–5
- pin assignments, 5–3
- protocol, 5–5
- request to send (RTS), 5–4
- X–ON/X–OFF protocol, 5–5
- RS–232 serial interface signals, 5–4
  - data terminal ready (DTR), 5–4
  - received data (RD), 5–4
  - transmitted data (TD), 5–4
- RS–422 serial interface, 5–3
  - ACK/NAK protocol, 5–5
  - configuration, 5–6
  - DTR protocol, 5–5
  - error handling, 5–5
  - ETX/ACK protocol, 5–5
  - framing error handling, 5–5
  - overflow error handling, 5–6
  - parity error handling, 5–5
  - pin assignments, 5–3
  - protocol, 5–5
  - X–ON/X–OFF protocol, 5–5
- RS–422 serial interface signals, 5–4
  - received data (RD), 5–4
  - transmitted data (TD), 5–4
- RTS, definition, Glossary–11

## S

- SA, definition, Glossary–11
- SAA, definition, Glossary–11
- Sans serif, definition, Glossary–11
- Save current values parameter, 4–18

- Saving a configuration, 3–20
- Scale, paper, 2–41
- SCS, definition, Glossary–11
- Select SFCC parameter, P-Series emulation, 4–62
- Serial communications, definition, Glossary–11
- Serial interface
  - one char enquiry, 5–6
  - poll character, 5–6
  - RS–232, 5–3
  - RS–422, 5–3
- Serial interface menu, 4–44
  - baud rate, 4–45
  - buffer size in kilobytes, 4–47
  - data bits, 4–46
  - data protocol, 4–45
  - data terminal ready, 4–46
  - interface type, 4–45
  - one char enquiry, 4–48
  - parity, 4–46
  - Poll character, 4–47
  - request to send, 4–47
  - stop bits, 4–46
- Serial Matrix emulation menu, 4–68
  - alternate set 80–9F, 4–72
  - auto LF, 4–71
  - character sets, 4–70
  - control code 06, 4–71
  - define CR code, 4–71
  - define LF code, 4–72
  - overstrike, 4–71
  - print language, 4–70
  - printer select, 4–72
- Serial Matrix print language menu, 4–69
- Serial matrix printing, vs. line matrix printing, B–1

SERVICE MENU, 6–23

Service, routine, 6–1

Set, definition, Glossary–11

Set platen at bottom of form parameter, 4–13

Set Ribbon Size parameter, 7–6

Setting up the printer, 2–1

Setup, shipping restraints removal

- cabinet models, 2–12
- pedestal models, 2–18

SFCC sequence, definition, Glossary–12

Shipping restraints, removal

- cabinet models, 2–12
- pedestal models, 2–18

Shuttle, definition, Glossary–12

Shuttle timeout parameter, 4–13

Signals

- Dataproducts parallel interface, 5–11
- IEEE 1284 interface, 5–14
- PC parallel interface, 5–8
- RS–232 serial interface, 5–4
- RS–422 serial interface, 5–4

Site requirements, printer, 2–5

Size, type, definition, Glossary–12

SLD, definition, Glossary–12

Slew, definition, Glossary–12

Slew relative parameter, P-Series XQ

- emulation, 4–67

SNA, definition, Glossary–12

SOH, definition, Glossary–12

Spacing, definition, Glossary–12

Specifications

- acoustic noise level, A–5
- dimensions, printer, A–4
- electrical, A–6

- environmental, A–5
- humidity, relative, A–5
- interfaces, A–8
- labels, A–3
- paper, A–3
- printer, A–1
- ribbon, A–2
- temperature, A–5
- weight, printer, A–4

Speed, printing and plotting, B–4

SSCC, definition, Glossary–12

Start bits, definition, Glossary–12

Stop bits, definition, Glossary–12

Stop bits parameter, 4–46

String, definition, Glossary–12

Strobe polarity parameter

- Dataproducts, 4–42
- PC parallel, 4–39

Style, type, definition, Glossary–12

Switch, power, location, 2–43

Symbol set, definition, Glossary–12

## T

TCB, definition, Glossary–12

TD, definition, Glossary–12

Temperature requirements, 2–5, A–5

Terminating resistor configuration, 5–17

Test, running self-tests, 6–8

TESTING HARDWARE / PLEASE WAIT, 6–23

Tests

- after installation, 2–50
- diagnostic, 6–7

Theory, line matrix printing, B–1

Time  
  power-on, 4–82  
  printing, 4–82

TOF, definition, Glossary–12

TOF action at prime signal parameter, 4–40

TOF indicator, location, 2–48

TOP OF FORM SET, 6–23

Top-of-form, setting, 2–47

Tractor gates shown, 2–40

Tractor lock, shown, 2–40

Translate table parameter, 4–31

Transmitted data (TD) signal  
  RS–232 serial interface, 5–4  
  RS–422 serial interface, 5–4

TTL, definition, Glossary–13

Twinax interface menu, 4–19  
  active print language, 4–21  
  cancel buffers, 4–22  
  early print complete, 4–22  
  format control, 4–25  
  hex print mode, 4–25  
  hex transparent control, 4–23  
  load alternate character, 4–24  
  override host, 4–24  
  print character table, 4–21  
  print language, 4–21  
  print text direction, 4–24  
  printer address, 4–22  
  printer emulation, 4–21  
  undefined character reporting, 4–23  
  undefined character substitution, 4–23  
  world trade, 4–22

Type, definition, Glossary–5

Type family, definition, Glossary–13

Type size, definition, Glossary–13

Type style, definition, Glossary–13

Typeface, definition, Glossary–13

Typographic font, definition, Glossary–13

## U

Undefined character reporting parameter,  
  4–23

Undefined character substitution parameter,  
  4–23

Underlines test, 4–81, 6–7

Unidirectional printing, 4–11

Unlocking program mode, 3–7

Unpacking a new printer, 2–12

UPC, definition, Glossary–13

Upper case select parameter, P-Series XQ  
  emulation, 4–67

USET, definition, Glossary–13

## V

Vertical formatting features  
  electronic vertical formatting, 1–9  
  EVFU for Epson mode, 1–9  
  vertical tabbing (Serial Matrix, Proprinter,  
    and Epson), 1–9

VFU, definition, Glossary–13

## W

warm start, definition, Glossary–13

Warning notice description, 1–2

Weight  
  definition, Glossary–13  
  of printer, A–4

World trade parameter, 4–22

Write, definition, Glossary–13

## X

X–ON/X–OFF protocol  
  RS–232 serial interface, 5–5  
  RS–422 serial interface, 5–5





© Copyright IBM Corp., 1995, 1996, 1997



S246-0116-02