

InfoPrint Hi-Lite Color



# Introduction and Planning Guide



InfoPrint Hi-Lite Color



# Introduction and Planning Guide

**Note**

Before using this information and the product it supports, be sure to read the general information in "Notices" on page xi.

**Second Edition (March 1998)**

The following paragraph does not apply to any other country where such provisions are inconsistent with local law.

INTERNATIONAL BUSINESS MACHINES CORPORATION PROVIDES THIS PUBLICATION "AS IS" WITHOUT WARRANTY OF ANY KIND, EITHER EXPRESS OR IMPLIED, INCLUDING, BUT NOT LIMITED TO THE IMPLIED WARRANTIES OF MERCHANTABILITY OR FITNESS FOR A PARTICULAR PURPOSE. Some states do not allow disclaimer of express or implied warranties in certain transactions, therefore, this statement may not apply to you.

Requests for IBM publications should be made to your IBM representative, or to your IBM branch office serving your locality. If you request publications from the address given below, your order will be delayed because publications are not stocked there.

A Reader' Comments form is provided at the back of this publication. If the form has been removed, you can send comments by fax to 1-800-524-1519, by E-mail to [print\\_pubs@vnet.ibm.com](mailto:print_pubs@vnet.ibm.com), or by mail to:

IBM Printing Systems Company  
Department H7FE, Building 003G  
Information Development  
P.O. Box 1900  
Boulder CO USA 80301-9191

IBM may use or distribute whatever information you supply in any way it believes appropriate without incurring any obligation to you.

Visit our home page at: <http://www.printers.ibm.com>

© **Copyright International Business Machines Corporation 1997. All rights reserved.**

Note to U.S. Government Users — Documentation related to restricted rights — Use, duplication or disclosure is subject to restrictions set forth in GSA ADP Schedule Contract with IBM Corp.

---

# Contents

<b>Figures</b> . . . . .	vii
<b>Tables</b> . . . . .	ix
<b>Notices</b> . . . . .	xi
Trademarks . . . . .	xi
Communication Statements . . . . .	xi
<b>Preface</b> . . . . .	xv
About This Publication . . . . .	xv
HCPP Publications . . . . .	xv
Related Publications . . . . .	xvi
<b>Chapter 1. Product Description</b> . . . . .	1
Product Summary . . . . .	1
Purpose . . . . .	1
The Highlight Color Printing Process . . . . .	1
HCPP Characteristics . . . . .	3
Printheads . . . . .	3
Ink . . . . .	3
Forms Path . . . . .	3
Preheat Control . . . . .	3
Display/Control Panel Assembly . . . . .	4
Service Console . . . . .	4
Forms Handling . . . . .	4
Print Material . . . . .	4
Print Area . . . . .	4
Host Printer Attachment . . . . .	5
Post-Processing After HCPP . . . . .	5
Host Printer Pre-Processing . . . . .	5
Power Control . . . . .	6
Maximum Percentage of Coverage . . . . .	6
Host Attachment . . . . .	6
System Components . . . . .	6
Performance . . . . .	7
Application Environment . . . . .	7
Reliability, Availability, and Serviceability . . . . .	7
Security Considerations . . . . .	8
HCPP and Host Printer Configurations . . . . .	8
Simplex Configuration . . . . .	9
Inline Duplex Configuration with HCPP . . . . .	10
Left Angle Duplex Configuration with HCPP . . . . .	11
Dual Simplex Configuration with HCPP . . . . .	12
<b>Chapter 2. Organizing the Planning Team</b> . . . . .	13
Planning Coordinator . . . . .	13
Physical Planner . . . . .	13
System and Application Programmers . . . . .	14
Operator . . . . .	14
Implementation Plan . . . . .	14
Fifteen Weeks before Delivery . . . . .	14
Ten Weeks before Delivery . . . . .	15
Six Weeks before Delivery . . . . .	15

Four Weeks before Delivery . . . . .	15
Arrival of HCPP and Ink . . . . .	16
<b>Chapter 3. Preparing the Physical Environment . . . . .</b>	<b>17</b>
Environmental Requirements . . . . .	17
Shipping Crate Dimensions . . . . .	18
Environmental Impact . . . . .	18
Heat and Power . . . . .	18
Sound . . . . .	18
Physical Requirements . . . . .	18
Power . . . . .	18
Power Cable and Receptacle . . . . .	19
Vacuum Cleaner . . . . .	20
Physical Layout . . . . .	20
Space Requirements . . . . .	21
Paper Interface Between the Host Printer and HCPP . . . . .	23
Physical Attachment Requirements . . . . .	23
Installation Requirements . . . . .	23
Installation Planning Work Sheet . . . . .	24
Physical Planning Work Sheet . . . . .	25
<b>Chapter 4. Software Requirements for Printing Highlight Color Information . . . . .</b>	<b>27</b>
Required IBM Software . . . . .	27
Optional AFP Software . . . . .	27
Required Program Updates . . . . .	28
New AFP Color Support Technical Reference . . . . .	28
<b>Chapter 5. Application Development Guidelines . . . . .</b>	<b>29</b>
Available Highlight Color Coverage on the Form . . . . .	29
Ink Color Availability . . . . .	32
Highlight Color Availability . . . . .	32
Example of Highlight Color Application . . . . .	33
Bitmaps . . . . .	36
Setup Concepts . . . . .	37
Loading Setups . . . . .	40
An Example Using Prerequisite and Hidden Setups . . . . .	40
System Level Setup Verification . . . . .	41
Setup Verification Process . . . . .	42
Verifying the Setup ID from an MVS Host . . . . .	43
Placing Color on the Correct Side of the Form . . . . .	44
Loading Forms Correctly in a Host Printer Simplex Configuration . . . . .	45
Loading Forms Correctly in a Host Printer Duplex Configuration . . . . .	45
Verification of Color on the Correct Side of the Form . . . . .	46
Registration . . . . .	47
Registration to the Edge of the Form . . . . .	47
Print Head Skew . . . . .	49
Procedures to Improve Registration . . . . .	49
<b>Chapter 6. Ordering Considerations . . . . .</b>	<b>51</b>
Host Printer Requirements . . . . .	51
Umbilical Connections . . . . .	52
<b>Chapter 7. Ordering Supplies . . . . .</b>	<b>55</b>
Standard and Custom Ink Colors . . . . .	55
Ordering Standard Ink Colors . . . . .	55
Ordering Custom Ink . . . . .	55

Storing and Handling of Ink . . . . .	55
Ink Consumption Rates . . . . .	55
<b>Chapter 8. Selecting and Testing Forms . . . . .</b>	<b>57</b>
Continuous Forms . . . . .	57
Special-Purpose Materials . . . . .	57
Preprinted Forms. . . . .	58
Adhesive Labels . . . . .	58
Storing Print Materials . . . . .	58
Questions and Answers about Testing Forms and Applications . . . . .	58
What is an Ideal HCPP Application?. . . . .	58
What Would Make My Application Different from the Ideal? . . . . .	58
What Will Testing Tell Me? . . . . .	59
What Kind of Testing Should I Do? . . . . .	60
<b>Appendix A. Setup Design Worksheet . . . . .</b>	<b>61</b>
<b>Appendix B. Acronyms and Abbreviations . . . . .</b>	<b>69</b>
<b>Glossary . . . . .</b>	<b>73</b>
<b>Index . . . . .</b>	<b>81</b>





---

# Figures

1. System Configuration . . . . .	2
2. Printable Page Area . . . . .	5
3. HCPP System Components.. . . . .	6
4. Hubbell Plug and Receptacle . . . . .	20
5. Dimensions, Service Clearance, and Cable Locations. . . . .	22
6. Printhead carriage assemblies and printheads . . . . .	29
7. Printhead coverage area . . . . .	30
8. Abutted printhead coverage areas. . . . .	30
9. Overlapped coverage areas . . . . .	31
10. Printheads and Form Orientation . . . . .	32
11. HCPP input . . . . .	33
12. HCPP highlight color . . . . .	34
13. HCPP output . . . . .	35
14. Bitmap orientation . . . . .	36
15. Setup Design Worksheet . . . . .	37
16. Virtual printhead . . . . .	39
17. Second Level of System Setup Verification . . . . .	42
18. 90° Flipper . . . . .	46
19. Buffer/Flipper-Straight Line . . . . .	46
20. Overspraying Highlight Text . . . . .	48
21. Overspraying Solid Areas With Black Borders . . . . .	48



---

## Tables

1.	HCPP Temperature Conditions . . . . .	17
2.	Shipping Crate Dimensions . . . . .	18
3.	Heat Dissipation and Power . . . . .	18
4.	Electrical Requirements . . . . .	19
5.	Physical Dimensions . . . . .	21
6.	HCPP Installation Planning Work Sheet . . . . .	24
7.	HCPP Physical Planning Work Sheet . . . . .	25
8.	MMC (X'D3A788') Syntax . . . . .	43



---

## Notices

References in this publication to IBM products, programs or services do not imply that IBM intends to make these available in all countries in which IBM operates. Any reference to an IBM licensed product, program, or service is not intended to state or imply that only IBM's product, program, or service may be used. Any functionally equivalent product, program, or service that does not infringe any of IBM's intellectual property rights may be used instead of the IBM product. Evaluation and verification of operation in conjunction with other products, except those expressly designated by IBM, is the user's responsibility.

Any performance data contained in this document was obtained in a controlled environment based on the use of specific data. The results that may be obtained in other operating environments may vary significantly. Users of this document should verify the applicable data in their specific environment. Therefore, such data does not constitute a performance guarantee or warranty.

IBM may have patents or pending patent applications covering subject matter in this document. The furnishing of this document does not give you any license to these patents. You can send license inquiries, in writing, to the IBM Corporation, IBM Director of Licensing, 208 Harbor Drive, Stamford, Connecticut, United States, 06094.

---

## Trademarks

The following terms, used in this publication, are trademarks of the IBM Corporation in the United States or other countries or both:

- Advanced Function Presentation (AFP)
- AFCCU
- AIX®
- AS/400®
- IBM®
- Intelligent Printer Data Stream (IPDS)
- MO:DCA
- Print Service Facility (PSF)
- RETAIN

---

## Communication Statements

### *Federal Communications Commission (FCC) Statement*

**Note:** This equipment has been tested and found to comply with the limits for a Class A digital device, pursuant to Part 15 of the FCC Rules. These limits are designed to provide reasonable protection against harmful interference when the equipment is operated in a commercial environment. This equipment generates, uses, and can radiate radio frequency energy and, if not installed and used in accordance with the instruction manual, may cause harmful interference to radio communications. Operation of this equipment in a residential area is likely to cause harmful interference, in which case the user will be required to correct the interference at his own expense.

IBM is not responsible for any radio or television interference caused by unauthorized changes or modifications to this equipment. Unauthorized changes or modifications could void the user's authority to operate the equipment.

This device complies with Part 15 of the FCC Rules. Operation is subject to the following two conditions: (1) this device may not cause harmful interference, and (2) this device must accept any interference received, including interference that may cause undesired operation.

**Canadian Department of Communications compliance statement:** This Class A digital apparatus meets the requirements of the Canadian Interference-Causing Equipment Regulations.

**The United Kingdom Telecommunications Act 1984:** This apparatus is approved under approval No. NS/G/1234/J/100003 for the indirect connections to the public telecommunications systems in the United Kingdom. **Canadian Department of Communications Compliance Statement:** This Class A digital apparatus meets the requirements of the Canadian Interference-Causing Equipment Regulations.

**Avis de conformité aux normes du ministère des Communications du Canada:** Cet appareil numérique de la classe A respecte toutes les exigences du Règlement sur le matériel brouilleur du Canada.

**Statement for CISPR 22 Edition 2 Compliance:** Warning: This is a Class A product. In a domestic environment this product may cause radio interference in which case the user may be required to take adequate measures.

**Japanese VCCI:**

<p>この装置は、第一種情報装置（商工業地域において使用されるべき情報装置）で商工業地域での電波障害防止を目的とした情報処理装置等電波障害自主規制協議会（VCCI）基準に適合しております。</p> <p>従って、住宅地域またはその隣接した地域で使用すると、ラジオ、テレビジョン受信機等に受信障害を与えることがあります。</p> <p>取扱説明書に従って正しい取り扱いをして下さい。</p>	VCCI
--	------

**European Community (EC) Conformity Statement:** This product is in conformity with the protection requirements of EC Council Directive 89/336/EEC on the approximation of the laws of the Member States relating to electromagnetic compatibility. IBM cannot accept responsibility for any failure to satisfy the protection requirements resulting from a non-recommended modification of the product, including the fitting of non-IBM option cards.

**German Conformity Statement:** Dieses Gerät erfüllt die Bedingungen der EN 55022 Klasse A. Für diese Klasse von Geräten gilt folgende Bestimmung nach dem EMVG:

Geräte dürfen an Orten, für die sie nicht ausreichend entstört sind, nur mit besonderer Genehmigung des Bundesministers für Post und Telekommunikation oder des Bundesamtes für Post und Telekommunikation betrieben werden. Die Genehmigung wird erteilt, wenn keine elektromagnetischen Störungen zu erwarten sind.

(Auszug aus dem EMVG vom 9.Nov.92, Para.3, Abs.4)

**Shielded Cables (European Statement)** Properly shielded and grounded cables must be used in order to reduce the potential for causing interference to radio and TV communications and to other electrical or electronic equipment. Such cables and connectors are available from IBM authorized dealers. IBM cannot accept responsibility for any interference caused by using other than recommended cables and connectors.





---

## Preface

This publication introduces the InfoPrint Hi-Lite Color Model HC2, also called the Highlight Color Post-Processor (HCPP). The HCPP is an IBM type 4005 Model HC2. This publication contains information to help you prepare for installation and use of the HCPP.

---

## About This Publication

This publication contains the following chapters:

- “Chapter 1. Product Description” on page 1 gives an overview of HCPP characteristics and basic highlight color concepts. The hardware and software components involved in printing highlight color information are identified.
- “Chapter 2. Organizing the Planning Team” on page 13 describes the installation planning team and specifies the tasks for which each team member is responsible.
- “Chapter 3. Preparing the Physical Environment” on page 17 specifies the HCPP environmental, electrical, and space requirements.
- “Chapter 4. Software Requirements for Printing Highlight Color Information” on page 27 describes the Advanced Function Presentation (AFP) and system product requirements for printing highlight color information.
- “Chapter 5. Application Development Guidelines” on page 29 describes the programming techniques needed to begin designing new highlight color applications or to add color to existing applications.
- “Chapter 6. Ordering Considerations” on page 51 describes some of the things to consider when ordering a HCPP.
- “Chapter 7. Ordering Supplies” on page 55 describes the process for ordering supplies for the HCPP.
- “Chapter 8. Selecting and Testing Forms” on page 57 describes the basic requirements for forms used in the HCPP and describes methods for evaluating them.
- “Appendix A. Setup Design Worksheet” on page 61 contains setup design worksheets for customer use.
- “Appendix B. Acronyms and Abbreviations” on page 69 defines acronyms and abbreviations used with the host printer and HCPP.
- “Glossary” on page 73 defines the terms used with the host printer and HCPP.

---

## HCPP Publications

The following is a listing of related publications for the HCPP.

- *InfoPrint Hi-Lite Color Operator's Guide*, Form S544-5421, describes the procedures required to operate the HCPP.
- *InfoPrint Hi-Lite Color Application Design Guide*, ask your IBM Marketing representative for a copy of this document from PEN PUBS (4005HCAP).
- *InfoPrint Hi-Lite Color Safety Information*, Form S544-5479, list all the caution and danger statements applicable to the InfoPrint Hi-Lite Color in different languages.

The following is a listing of available related publications for the host printers which support the HCPP, the 3900 and InfoPrint 4000 printer.

- *InfoPrint 4000 and 3900 Advanced Function Printers Introduction and Planning Guide* , G544-5427, summarizes the printer's functions and describes how to plan for a successful installation.
- *3900 Advanced Function Printer Models-0W1 and 0W3 Operator's Guide* , G544-3951, describes the procedures required to operate the Models-0W1 and 0W3 Advanced Function Printer.
- *3900 Advanced Function Duplex and Wide Duplex Printing Systems Operator's Guide*, G544-3920, describes the procedures required to operate the Advanced Function Wide Duplex Printing System.
- *InfoPrint 4000 Operator's Guide* , S544-5428, describes the procedures required to operate the InfoPrint 4000 printing system.
- *IBM General Information Manual: Installation Manual—Physical Planning* , GC22-7064.
- *IPDS Handbook for Printers That Use the Advanced Function Common Control Unit* , G544-3895, contains technical information about the host-to-printer data stream, resident and download font support, and exception reporting.
- *Forms Design Reference for Advanced Function Continuous Forms Printers* , G544-3921, describes the characteristics of forms and special-use media, and describes their effects on performance.

---

## Related Publications

The following is a listing of related publications for Advanced Function Presentation.

- *PPFA User's Guide*, S544-5284
- *AFP Toolbox for Multiple Operating Systems User's Guide*, S544-5292
- An extensive listing of available publications is included in *Advanced Function Presentation: Printer Information*, G544-3290 and *Guide to Advanced Function Presentation*, G544-3876.
- *DCF User's Guide* , S544-3191
- *OGL User's Guide* , S544-3702
- *AFP Programming Guide and Line Data Reference* , S544-3884
- *Mixed Object Document Content Architecture Reference (MO:DCA)* , SC31-6802
- *Intelligent Printer Data Stream Reference* , S544-3417

Contact your IBM marketing representative or your IBM printing system specialist for information concerning other publications or associated licensed programs.

---

## Chapter 1. Product Description

The InfoPrint Hi-Lite Color Model HC2 is a highlight color post-processor device attached to selected models of the 3900 and InfoPrint 4000 high speed laser printers. It is designed to add variable color data on one side of the output from the simplex or duplex host printer. (The "host printer" refers to the high speed laser printer attached to the highlight color post-processor.) The variable color is translucent to the host printer toner and can be used to highlight the output from the host printer or be used to print images, text, and graphics. The output of the Highlight Color Post-Processor (HCPP) must pass to a post-processor for folding, stacking, cutting and the like.

---

### Product Summary

The HCPP is designed to meet the following criteria:

- Same environmental conditions as the host printer.
- Most of the same papers as the host printer.
- Same safety and environmental standards as the host printer.
- The Model/Type 4005/HC2 HCPP print width is 21.87 cm (8.53 inch). This print width can be positioned anywhere across the entire form (up to 42.5 cm (17 inch) wide) in 2.72 cm (1.06 in) segments at the beginning of a print job.
- Up to three standard or custom ink colors can be used on a print job.
- Supported host printers:
  - Wide Simplex: 3900 models 0W1/0W3 (with or without 310 impression per minute (IPM) feature on 0W1).
  - Wide Duplex: 3900 models DW1/DW2 (with or without High Speed 458 IPM duplex feature).
  - InfoPrint 4000: All 240 dpi models.
- 240 pel per inch resolution. (The host printer must be set to 240 pel per inch resolution for HCPP operation even if the host printer supports other resolutions.)

---

### Purpose

The HCPP fills the following customer needs:

- Color in a high speed production print environment.
- Variable data color.
- Custom color capability for printing corporate and other colors correctly.
- Cost effective color printing.

---

### The Highlight Color Printing Process

Figure 1 on page 2 illustrates the hardware and software components involved in printing highlight color information.

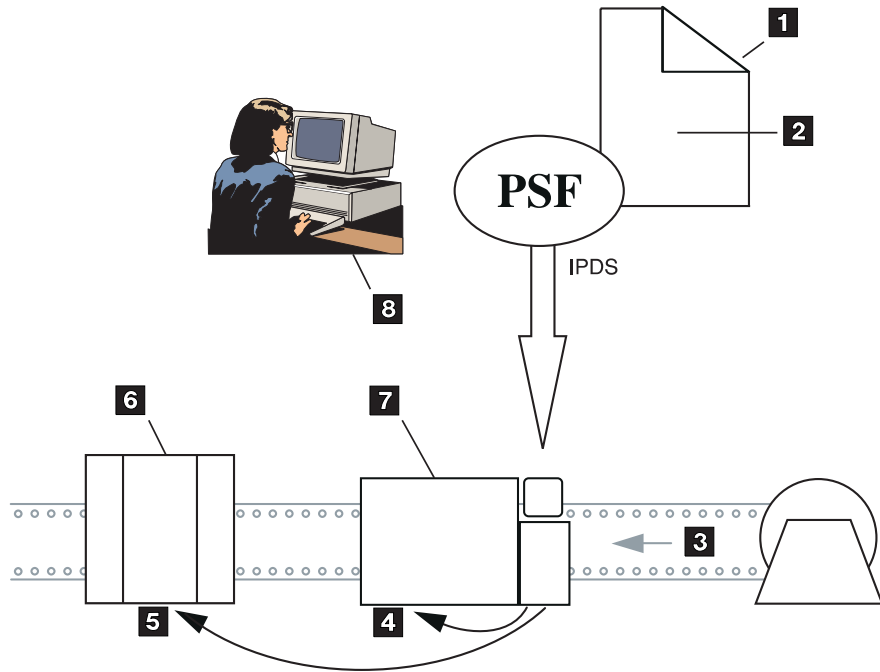

C6PI0007

Figure 1. System Configuration

- 1 AFP Document
- 2 Overlays, page segments, line data, in B/W, and color
- 3 Forms
- 4 B/W
- 5 Color
- 6 HCPP
- 7 Host printer
- 8 Application Program

The following is a description of the highlight color printing process:

1. An application programmer produces a document. These documents must conform to IBM's Advanced Function Presentation (AFP) architecture. The application programmer designs the print job, which may consist of multiple documents incorporating both black and white (B/W) and highlight color elements. A print job may also contain line data.
2. The print job is submitted to IBM's Print Services Facility (PSF) for printing. PSF is a required software program that translates the print job into IPDS for the host printer.
3. The Advanced Function Common Control Unit (AFCCU) in the host printer receives the Intelligent Printer Data Stream (IPDS) from PSF. It separates the black print elements from the color print elements. The AFCCU sends the black print elements to the host printer's laser printhead and sends the color print elements to the HCPP for printing.
4. The host printer advances the continuous forms through its forms path. As the forms pass under the laser printhead in the host printer, the black elements are printed on the form. When that form passes under the color inkjet printheads in

the HCPP, the color elements are printed on the form. The AFCCU manages synchronization of the forms between the host printer and the HCPP and manages all error recovery.

5. The forms output from the HCPP continues to additional post-processors for rewinding, folding, stacking, cutting, or inserting.

---

## HCPP Characteristics

The HCPP uses color inkjet technology to print the data received from the host printer's AFCCU. The data from the AFCCU is all-points-addressable print data, allowing high-quality text, image, graphics, and electronic overlays to be printed in color.

## Printheads

The system uses eight independently-positioned inkjet printheads. Each print head can print an area of 2.72 cm (1.06 in, or 6.3 picas or 76.3 points) wide parallel to the process direction of the forms through the HCPP. This allows a maximum coverage of 21.9 cm (8.53 inch). Therefore, care must be taken by the application programmer to assure that color pels appear only within predefined coverage areas on the form.

## Ink

The solid ink used in the HCPP is heated to a liquid state before being pumped to the printheads. Ink is orderable in an array of standard colors. A custom color design process is also available which allows custom ink colors to be used by the HCPP. The standard hardware configuration can accommodate up to 4 ink colors at one time in the system enclosure. A maximum of 3 colors can be used per print job.

## Forms Path

The HCPP contains an input loop control module which buffers the forms between the host printer and the HCPP, and allows the HCPP to match the speed of the host printer. The HCPP also contains an output loop control module which buffers the forms between the HCPP and additional post-processing devices. The input and output loop control modules allow the HCPP to backup and restart when the host printer stops and restarts. This backup operation is required to assure maximum print quality.

When the forms are in the HCPP they are preheated so that the color ink is absorbed into the paper. After printing by the inkjet printheads, the forms are cooled as they advance out of the HCPP.

If desired, the HCPP can be bypassed by passing the forms under the unit. This may require additional rollers that can be obtained from the post-processing vendor.

## Preheat Control

The HCPP allows the operator to vary the temperature of the preheat rollers depending on the type of paper. This ensures that the ink fuses (absorbs) properly to the printing surface of the form.

## Display/Control Panel Assembly

A display/control panel assembly within the HCPP allows the operator to control the operation of the HCPP through procedure windows and pull-down menus using a touch screen monitor. The Graphical User Interface (GUI) replicates the host printer GUI look and feel. For more information see *InfoPrint Hi-Lite Color Operator's Guide*.

## Service Console

The CE (Customer Engineer) uses the same display/control panel assembly as the operator, and selects different menus to run diagnostics and other maintenance procedures. For more information on the diagnostics package and service capabilities see *InfoPrint Hi-Lite Color Maintenance Information manual*.

---

## Forms Handling

The HCPP has forms loading assists to aid in threading of forms through the post-processor.

---

## Print Material

The forms material is the same as the host printer's.

---

## Print Area

The HCPP cannot print inside the tractor strip. See Figure 2 on page 5.

Print quality may be degraded when printing near folding or non-folding horizontal form perforations, an internal perforation, or any cut in the form. To ensure correct operation and print quality, maintain the following distances:

- From folding and non-folding horizontal form edge: 1.27 mm (0.05 inch)
- From internal perforations: 1.27 mm (0.05 inch)
- From folding perforations: for text, 8.5 mm (0.333 inch); for images and solid-area fill: 12.7 mm (0.5 inch)
- From binder holes and cuts: 2.54 mm (0.1 inch)

See *Forms Design Reference for Continuous Forms Advanced Function Printers* for more information.

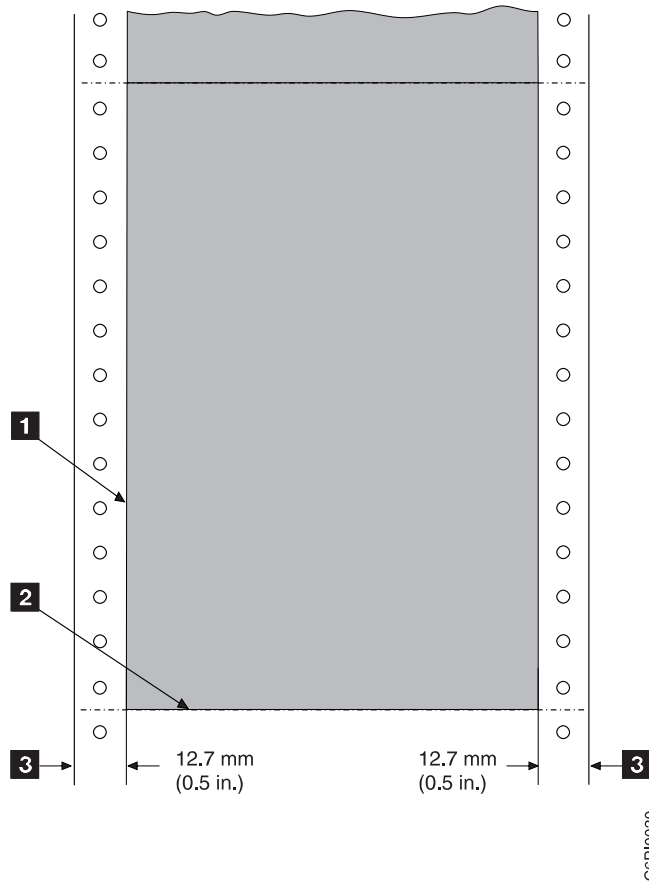

Figure 2. Printable Page Area

- 1 Vertical form edge
- 2 Horizontal form edge
- 3 Tractor strip

---

## Host Printer Attachment

The HCPP has the following attachments to the host printer:

1. SCSI interface - This is the high speed interface that is used by the host printer to send the color bit maps to the HCPP.
2. Post-processing interface - This is the interface used between the host printer and the HCPP for operating status and control.

---

## Post-Processing After HCPP

The HCPP does not have any output forms handling capabilities. Additional post-processing equipment is required. Contact your IBM Marketing representative for more information.

---

## Host Printer Pre-Processing

IBM recommends roll feed pre-processing equipment, rather than box feed for host printers attached to the HCPP.

---

## Power Control

The power control for the HCPP is independent of the host printer. Power control of the HCPP is accomplished by the use of circuit breakers on the control module assembly.

---

## Maximum Percentage of Coverage

The recommended maximum coverage of all ink colors on a page is 3%.

---

## Host Attachment

The HCPP is independent of the host printer's host attachment options or the choice of host computer operating systems. The application and system support for highlight color printing using the HCPP may not be available in all host operating systems. You should verify with your IBM Marketing representative that your intended application can be supported on your host operating system.

---

## System Components

The HCPP comes packaged as a single unit and includes the following:

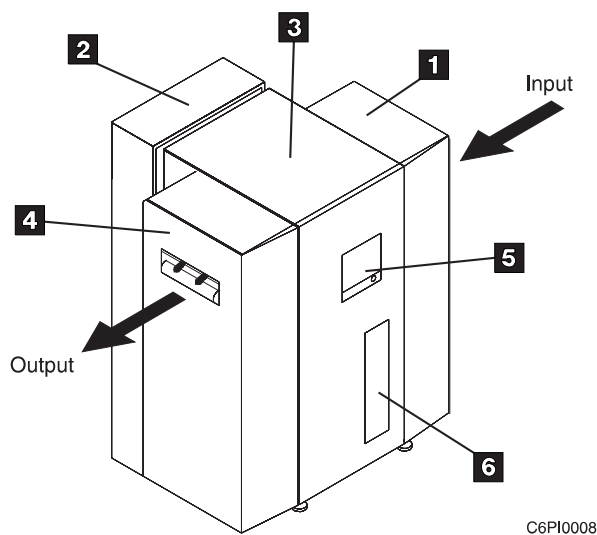

Figure 3. HCPP System Components.

- 1 — Input loop control module receives the forms from the host printer
- 2 — Control module contains the HCPP electronics
- 3 — Print engine houses the inkjet printheads and ink reservoirs
- 4 — Output loop control module presents forms to additional post-processors
- 5 — Display/Control panel assembly
- 6 — Reservoir module



---

## Performance

The HCPP system provides high-performance, high-quality highlight color post-processing for large-scale data-processing environments. For best performance, it is important that applications intended for the HCPP run at rated speed, and that “backhitching” of the host printer is minimized.

The AFCCU, to a large extent, determines the overall performance of the system. The following conditions affect the actual performance in your installation:

- Configuration of the host printer
- Number of characters per page
- Number of imbedded control commands
- Number of fonts, images, and overlays per page
- Performance of the host computer
- Host and network activity
- Attachment to the host

The forms output from the host printer becomes the forms input to the attached HCPP. The HCPP does not restrict the operation of the host printer.

---

## Application Environment

The host printer AFCCU generates the information that is sent to the HCPP to be printed and supports IBM’s AFP (Advanced Function Presentation) licensed programs.

---

## Reliability, Availability, and Serviceability

The HCPP is designed to ensure maximum reliability, availability, and serviceability. The following elements reflect this:

- **Message Display**

The operator display/control panel assembly can display messages in different languages. These messages give status information, request operator intervention, and guide operators through procedures that have more than one step. Help functions are available for most operations.

- **Error Log**

Sensors and microcode detect faults in the device. Information about faults is displayed to the operator and logged on the internal hard disk for use in correcting problems.

- **Traces**

The HCPP can perform software traces. It can record detailed information about the device activities and communications with the host printer. The key operator can collect software traces for analysis when instructed to do so by IBM.

- **Print Samples**

Print samples are available for operators and service personnel whenever necessary to sample print quality, solve problems, and adjust the device. The print samples are available from the host printer operator’s panel. They include both black and color print elements which allows the operator to check and calibrate the print registration between the host printer and HCPP.

---

## Security Considerations

A design philosophy for HCPP is that security of access to the machine and its output is the domain of the user -- not the product. Data integrity, of course, is a machine criterion.

There are no physical security functions or features available on HCPP. Access is controlled by the user with physical means (for example, machine installed in a lockable room.)

Prevention of data loss is managed and controlled by the host printer AFCCU. All lost pages associated with forms jams or system problems are recovered and reprinted by the host printer in association with host software.

There is no provision to erase residual print data from HCPP storage.

The entire machine is available for maintenance purposes. There are no security considerations designed to alter this premise.

There is no undetected data loss potential due to maintenance procedures.

The HCPP is designed to operate in a controlled machine room environment, for example a computing center.

A dedicated operator is neither expected or required.

Disaster recovery at an alternate device or location is the responsibility of the customer.

---

## HCPP and Host Printer Configurations

The HCPP prints color on one side of the form and is designed to be used with the following host printer configurations:

- **Simplex.** A simplex host printer configuration uses one printer to print on one side of the form. See "Simplex Configuration" on page 9 for simplex operation.
- **Duplex.** A duplex host printer configuration uses two host printers. The first printer, designated Printer 1, prints on one side of the form. The next printer, designated Printer 2, prints on the other side of the form after passing through the Buffer/Flipper Unit which inverts the form 180°. See "Inline Duplex Configuration with HCPP" on page 10 for inline duplex and "Left Angle Duplex Configuration with HCPP" on page 11 for left angle duplex.

The HCPP prints color on the same side of the form as Printer 2 unless there is a 90° flipper placed between the host printer and the HCPP. If the 90° flipper is placed between the host printer and the HCPP, the HCPP prints color on the same side as Printer 1.

- **Dual Simplex.** A dual simplex host printer configuration uses both printers separately in simplex mode; each printer is independent of the other and they can print different print jobs at the same time. See "Dual Simplex Configuration with HCPP" on page 12.

---

## Simplex Configuration

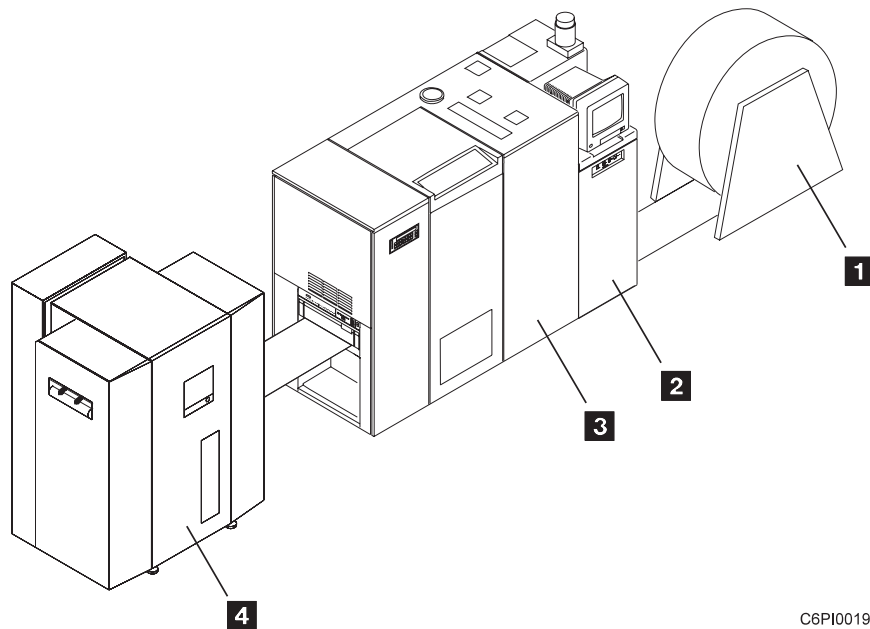

C6PI0019

- 1 — Optional pre-processing device for host printer
- 2 — AFCCU attached to host printer
- 3 — Host printer
- 4 — Optional post-processing device (can be a HCPP)

**Note:** In a simplex configuration, no flipper unit may be placed between the host printer and the HCPP. Only a “straight paper path” is supported.

A post-processing device is required after the HCPP.

Roll Feed paper is recommended rather than box feed for applications using the HCPP.

## Inline Duplex Configuration with HCPP

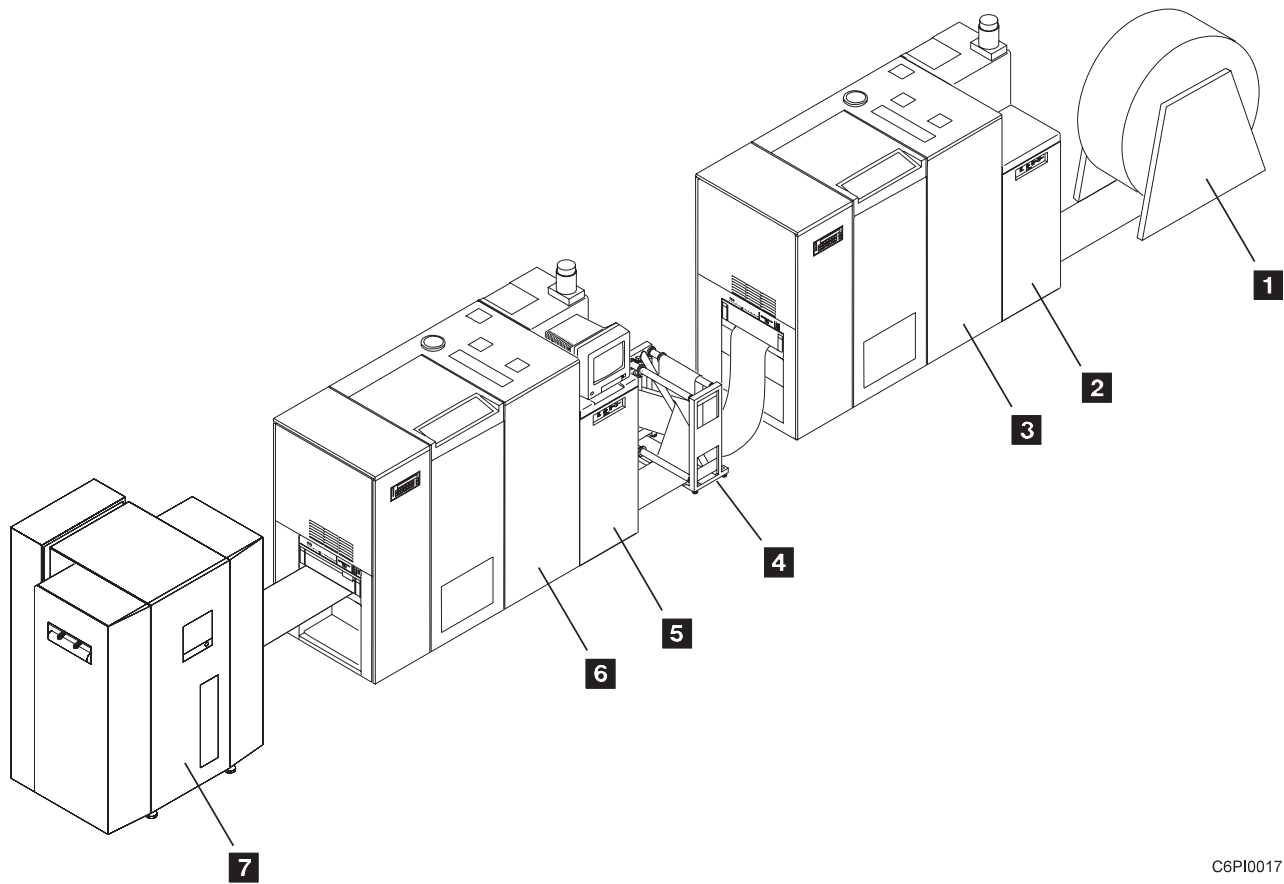

C6PI0017

- 1 — Optional pre-processing device for Printer 1
- 2 — Printer Utility Module attached to Printer 1
- 3 — Printer 1
- 4 — Buffer/Flipper Unit
- 5 — AFCCU attached to Printer 2
- 6 — Printer 2
- 7 — Optional post-processing device (can be a HCPP)

**Note:** If the HCPP is attached to an inline duplex host printer a 90° flipper device may be placed between printer 2 and the HCPP. This device is generally needed when space constraints preclude a “straight paper path” or when color printing is desired on the side of the form printed by Printer 1.

A post-processing device is required after the HCPP.

Roll Feed paper is recommended rather than box feed for applications using the HCPP.

## Left Angle Duplex Configuration with HCPP

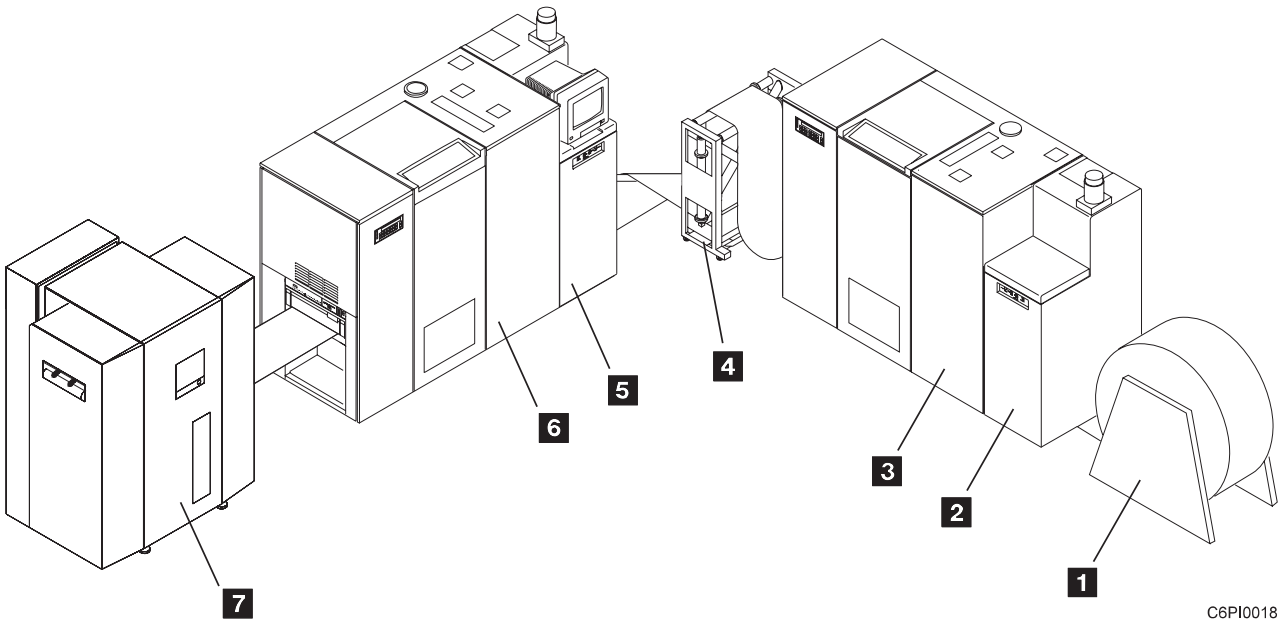

C6PI0018

- 1 — Optional pre-processing device for Printer 1
- 2 — Printer Utility Module attached to Printer 1
- 3 — Printer 1
- 4 — Buffer/Flipper Unit
- 5 — AFCCU attached to Printer 2
- 6 — Printer 2
- 7 — Optional post-processing device (can be a HCPP)

**Note:** If the HCPP is attached to a left angle duplex host printer, a 90° flipper device may be placed between printer 2 and the HCPP. This device is generally needed when space constraints preclude a “straight paper path” or when color printing is desired on the side of the form printed by Printer 1.

A post-processing device is required after the HCPP.

Roll Feed paper is recommended rather than box feed for applications using the HCPP.

## Dual Simplex Configuration with HCPP

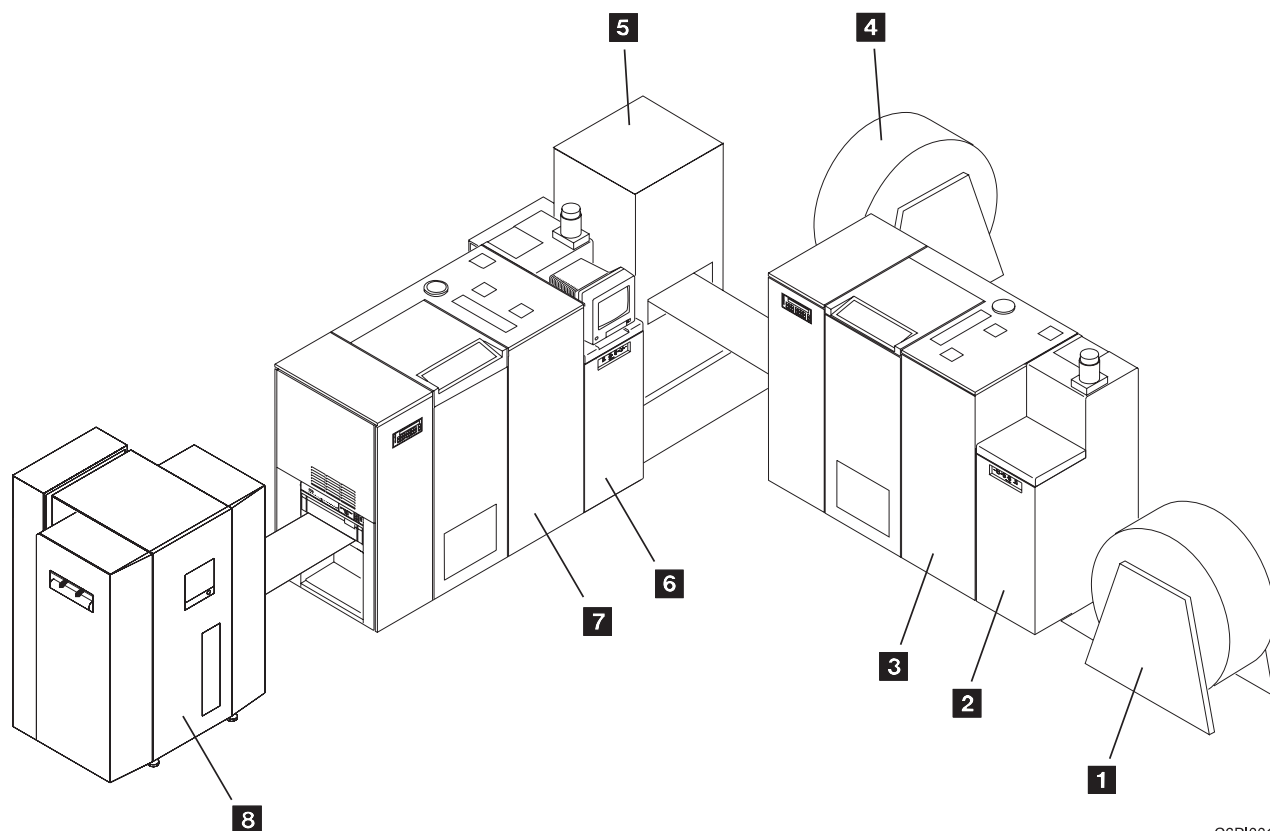

C6PI0016

- 1 — Optional pre-processing device for Printer 1
- 2 — Printer Utility Module attached to Printer 1
- 3 — Printer 1
- 4 — Optional pre-processing device for Printer 2
- 5 — Optional post-processing device for Printer 1 (can be a HCPP)
- 6 — AFCCU attached to Printer 2
- 7 — Printer 2
- 8 — Optional post-processing device for Printer 2 (can be a HCPP)

**Note:** In a dual simplex configuration, no flipper unit may be placed between the host printer and the HCPP (Only a “straight paper path” is supported).

A post-processing device is required after the HCPP.

Roll Feed paper is recommended rather than box feed for applications using the HCPP.

---

## Chapter 2. Organizing the Planning Team

The first step in preparing to install the HCPP is to select a planning coordinator. This person is responsible for organizing and managing a project team to plan, order, and install the HCPP and, if necessary, the AFP programs.

A typical planning team includes the following members:

- Planning coordinator
- Physical planner
- System programmer
- Application programmer

You may also want to include representatives from end-user areas as part of the planning team. Their input can be valuable in determining requirements for advanced printing functions and special-purpose materials.

---

### Planning Coordinator

Throughout the planning phase, the planning coordinator meets with the planning team and the IBM installation planning representative to ensure that all pre-installation tasks are proceeding smoothly. The “Implementation Plan” on page 14 is a checklist of these planning tasks.

The planning coordinator should read this entire publication to help the other team members prepare for the HCPP.

In addition to the tasks described in this publication, the planning coordinator should consider related issues, such as:

- **Training.** Who needs to be trained on the HCPP and on AFP? Who conducts the training sessions? When will training be scheduled?
- **Testing.** Who performs the HCPP and AFP tests? What applications should we test? What forms should we test? How can we conduct testing without affecting production schedules?
- **Implementation.** How will the HCPP be phased into production? What applications will use the HCPP?
- **Documentation.** Which local procedures do we need to change? Who is responsible for changing the local written procedures? Who needs copies of IBM hardware and software manuals?
- **Supplies.** How large should the initial HCPP supply order be? What is the local procedure for ensuring that supplies are kept in stock?

---

### Physical Planner

The physical planner is typically an industrial engineer or a supervisor. Physical planners determine the location for the HCPP and prepare a layout plan. They are responsible for ensuring that the HCPP’s environmental, electrical, and space requirements are met, and that the location is convenient for operators and Customer Engineers (CE).

IBM offers special assistance with physical planning. Contact your IBM marketing representative for information.

---

## System and Application Programmers

System and application programmers typically plan for and order the required AFP licensed programs.

System programmers are responsible for:

- Installing and testing the licensed programs
- Incorporating HCPP into the system configuration

For information about the HCPP system software requirements see “Chapter 4. Software Requirements for Printing Highlight Color Information” on page 27.

The application programmer creates and modifies print jobs that interact with the licensed programs. See “Chapter 5. Application Development Guidelines” on page 29 for information on highlight color applications.

Application programmers also participate in testing forms and applications. See “Chapter 8. Selecting and Testing Forms” on page 57 for more information on selecting and testing forms.

---

## Operator

Printer operators perform the following day-to-day tasks for HCPP and the attached host printer:

- Responding to the HCPP’s operational needs, such as loading forms and clearing forms jams
- Replenishing the HCPP’s supplies, such as ink
- Performing routine cleaning
- Checking and adjusting print quality
- Collecting software traces

*InfoPrint Hi-Lite Color Operator’s Guide* contains general operating procedures, and is the primary reference for HCPP operators.

---

## Implementation Plan

This checklist contains many of the major tasks that must be performed before and during HCPP’s installation. Use this checklist as a basis for developing your own detailed implementation project plan.

### Fifteen Weeks before Delivery

The *planning coordinator*:

1. Identifies the members of the planning team.
2. Orders the HCPP (and the host printer, or necessary host printer configuration changes).
3. Orders the IBM AFP licensed programs.
4. Prepares a plan for selecting and testing forms for use with HCPP.

The *physical planner*:



1. Determines the location for the HCPP and arranges for any changes to the site. Ensures that the site will have conductive flooring.
2. Identifies the delivery route for the HCPP.
3. Prepares a space layout plan.
4. Determines who installs the electrical wiring and outlets.
5. Determines the type of electrical attachment and ground-fault circuit protection to be used.

The *system programmer*:

1. Determines the AFP licensed programs needed.

The *application programmer*:

1. Identifies the applications that must be changed for migration to the HCPP.
2. Works with the Planning Coordinator to select ink colors.
3. Prepares a detailed plan for converting and testing applications that are used with the HCPP.

## Ten Weeks before Delivery

The *planning coordinator*:

1. Meets with the IBM installation planning representative to review the planning process.

The *physical planner*:

1. Schedules the installation of electrical wiring and outlets.

The *system programmer*:

1. Determines the administrative procedures for using AFP licensed programs.
2. Begins installing and testing the AFP licensed programs.

## Six Weeks before Delivery

The *planning coordinator*:

1. Works with the IBM marketing representative to select ink colors.
2. If custom ink colors are used, starts the custom ink color design process with the IBM marketing representative.

The *physical planner*:

1. Ensures that the electrical wiring and outlets are being installed on schedule.
2. Reviews site-preparation progress with the IBM installation planning representative.

## Four Weeks before Delivery

The *planning coordinator*:

1. If custom ink colors are used, completes design process.
2. Orders supply of custom ink colors.
3. Orders supply of standard ink colors.

The *physical planner*:

1. Completes installing and testing of electrical wiring and outlets.
2. Completes all site preparation.
3. Verifies that a forklift will be available to move the HCPP. See forklift requirements in "Installation Requirements" on page 23. If no forklift is available contact IBM.

## Arrival of HCPP and Ink

The *planning coordinator*:

1. Contacts the service representative and arranges to have the HCPP installed.
2. Completes the Printhead Requirements Worksheet (see 51).

**Note:** The CE installs the ink in the reservoirs as part of the installation. Some ink is consumed during installation. Make sure the ink is available during installation.

The *system programmer*:

1. Completes tests of the AFP licensed programs, including the IBM-supplied installation verification procedures.

The *physical planner and IBM CE* :

1. Unpacks the HCPP and inspects it for external damage.
2. Moves the HCPP to the designated location.

---

## Chapter 3. Preparing the Physical Environment

This chapter describes the environmental, power, physical, and space requirements for the HCPP and contains an installation-planning and physical-planning worksheet. The audience for this chapter is the physical planner and the system programmer.

---

### Environmental Requirements

Consider the following requirements as you select the location for your HCPP:

- Temperature and humidity

Extremes of temperature and relative humidity can affect forms and adversely affect machine performance. These affects may include forms jams and unacceptable print quality.

Table 1. HCPP Temperature Conditions

Mode	Temperature	Relative Humidity
Storage	-40 to 60°C -40 to 140°F	5 to 100% non- condensing
Shipment	-40 to 60°C -40 to 140°F	5 to 100% non- condensing
Nonoperating	-40 to 60°C -40 to 140°F	5 to 100% non- condensing
Recommended operating range	18 to 24°C 65 to 75°F	40-60%
Minimum/ Maximum operating range	16 to 29°C 60 to 84°F	20-80%

The recommended operating range above achieves and sustains the best machine performance and print quality.

- Ventilation

Dust and other contamination can cause machine faults. The HCPP operates best in an air-conditioned computer room with year-round humidity control and predominately recirculated, filtered air. See the *IBM General Information Manual: Installation Manual—Physical Planning*, GC22-7064, for details about ventilation requirements for other IBM equipment.

Human-health considerations dictate that appropriate ventilation be supplied to the HCPP and host printer. The American Society of Heating, Refrigeration, and Air Conditioning Engineers (ASHRAE) recommends a minimum of 0.42–0.57 cmm (15–20 cfm) per person of outdoor air make-up during human occupancy (ASHRAE 62–1989). Adherence to IBM pre-printed forms recommendations and provision of appropriate ventilation should preclude the development of adverse human-health effects because of outgassing and emissions from preprinted forms. See *Forms Design Reference for Advanced Function Continuous Forms Printers* for more information about selecting preprinted forms and using them safely.

---

## Shipping Crate Dimensions

The HCPP is shipped as one unit with the following dimensions and weight:

**Note:** The shipping container must be returned for reuse.

*Table 2. Shipping Crate Dimensions*

Height	Width	Depth	Weight
80.5 inch (204 cm)	71.62 inch (182 cm)	64.75 inch (164.5 cm)	500 pound (277 kg)

---

## Environmental Impact

Consider the heat and sound generated by the HCPP when selecting its location.

### Heat and Power

The heat dissipation values in the following table apply to the HCPP.

*Table 3. Heat Dissipation and Power*

	Idle		Printing		Sleeping	
	50 Hz	60 Hz	50 Hz	60 Hz	50 Hz	60 Hz
kVA	4	4	7	7	3	3
kBTU/Hr	13.6	13.6	23.9	23.9	10.2	10.2
<b>Note:</b> 50 Hz printing may be expected to operate within 10% of the 60 Hz values.						

### Sound

Operating levels are measured during continuous running with 20-pound forms. The mean value of the space-averaged sound pressure emission levels at the one-meter positions is 64 dB.

---

## Physical Requirements

Consider the electrical requirements for the HCPP when selecting its location. Use “Physical Layout” on page 20 and “Space Requirements” on page 21 for more information.

### Power

Ensure that you have an electrical outlet that supports 12 kVA and meets the power requirements listed in Table 4 on page 19. This outlet must supply 3-phase power and be able to disconnect power from each device, such as:

- A compatible plug and receptacle installed near the HCPP.
- A circuit breaker that breaks all live poles. This circuit breaker must be dedicated to the HCPP and be within easy reach.

Table 4. Electrical Requirements

Country	AC Voltages			Wiring Information	Phase	Circuit Rating
	Nominal	Minimum	Maximum			
U.S.A. Canada	60 Hz/208 60 Hz/220 60 Hz/230 60 Hz/240	60 Hz/187 60 Hz/198 60 Hz/207 60 Hz/216	60 Hz/229 60 Hz/242 60 Hz/252 60 Hz/264	4-wire power cable with three phases and ground. Neutral is not required.	3	30 A
Japan	50 Hz/200 60 Hz/200	50 Hz/180 60 Hz/180	50 Hz/220 60 Hz/220	4-wire power cable with three phases and ground.	3	30 A
Europe	50 Hz/380 50 Hz/400 50 Hz/415	50 Hz/332 50 Hz/360 50 Hz/374	50 Hz/418 50 Hz/440 50 Hz/456	5-wire power cable with three phases, ground, and neutral. Direct connection of neutral to ground required.	3	25 A
<b>Attention:</b>						
The 50 Hz 380/400/415 volt version does not support non-earthed neutral and impedance-grounded neutral power distribution systems. Installation on an impedance-grounded neutral power system (IT Power System) could result in failures of motors and transformers in the device.						

## Power Cable and Receptacle

An AC power cable is supplied with the HCPP and measures 427 cm (14 feet), except for devices installed in Chicago, Illinois, U.S.A., where the power cable measures 183 cm (6 feet).

### U.S., Canada, and Japan

The HCPP uses cords with Hubbell plugs, IBM part number 24H6820, or IBM part number 24H6821 for devices installed in Chicago; both include the cord and Hubbell plug type 430P9W. Provide either of the following Hubbell connector or receptacle (or equivalent) for this plug:

- 430C9W Connector (inline)
- 430R9W Receptacle (mounts on a wall or rail)

Figure 4 on page 20 shows a Hubbell cord, plug, and receptacle. Positions for phase connectors R1, S2, T3, and ground (G) are shown.

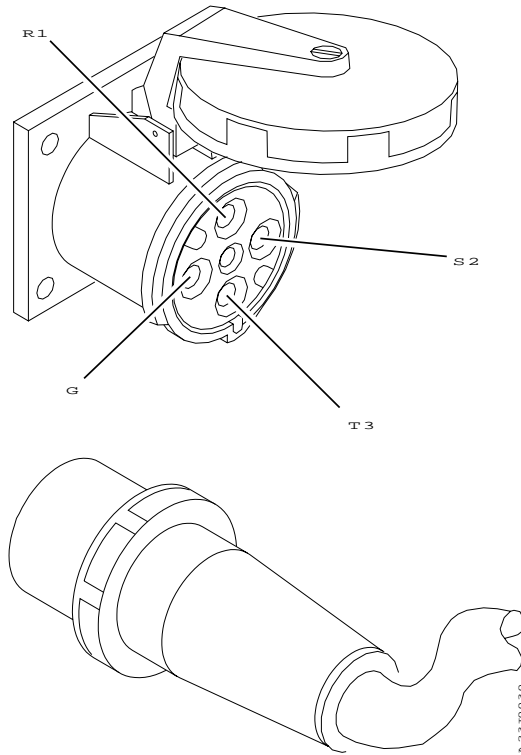

Figure 4. Hubbell Plug and Receptacle

### All Other Countries

The power cable is supplied without a plug and requires an appropriate plug and compatible receptacle.

Understand the electrical standards for your country, and use only an approved plug. Your IBM marketing representative has information on the voltage requirements in your country.

For more information about voltage requirements and for Hubbell part numbers, see the *IBM General Information Manual: Installation Manual—Physical Planning*, GC22-7064.

## Vacuum Cleaner

The vacuum cleaner used for the host printer meets the requirements for the HCPP.

## Physical Layout

As you plan your physical layout, be sure to:

- Install the HCPP away from the main traffic pattern. Allow space for operators and service representatives to perform their tasks. This space should not extend into walkways.
- Install the HCPP in a location that is convenient for the operator. For example, consider whether the planned location is close to the HCPP supply storage areas and to output distribution areas.

- Allow 101.6 cm (40 inches) between any outside surface of the HCPP and an adjacent wall to prevent ambient heat rise. see “Installation Requirements” on page 23 .
- Allow 203 cm (80 inches) between the floor and the lowest permanently attached object above the printer, such as a light or a cable rail. This layout gives printer operators and service representatives space in which to work.
- Check the route that the printer must travel from your loading dock to the installation location to ensure that it fits through the doorways and halls. The dimension of the frame is shown in Table 5

Table 5. Physical Dimensions

Dimension	HCPP
Depth (See Note)	1474 mm (58 in)
Height	1880 mm (74 in)
Length	1651 mm (65 in)
Weight	953 kg (2100 lb)
<b>Note:</b>  The HCPP is wider than a standard doorway.	

---

## Space Requirements

The dimensions, optimum distance from the host printer, service clearance, power and host printer cable locations for the HCPP is shown in Figure 5 on page 22.

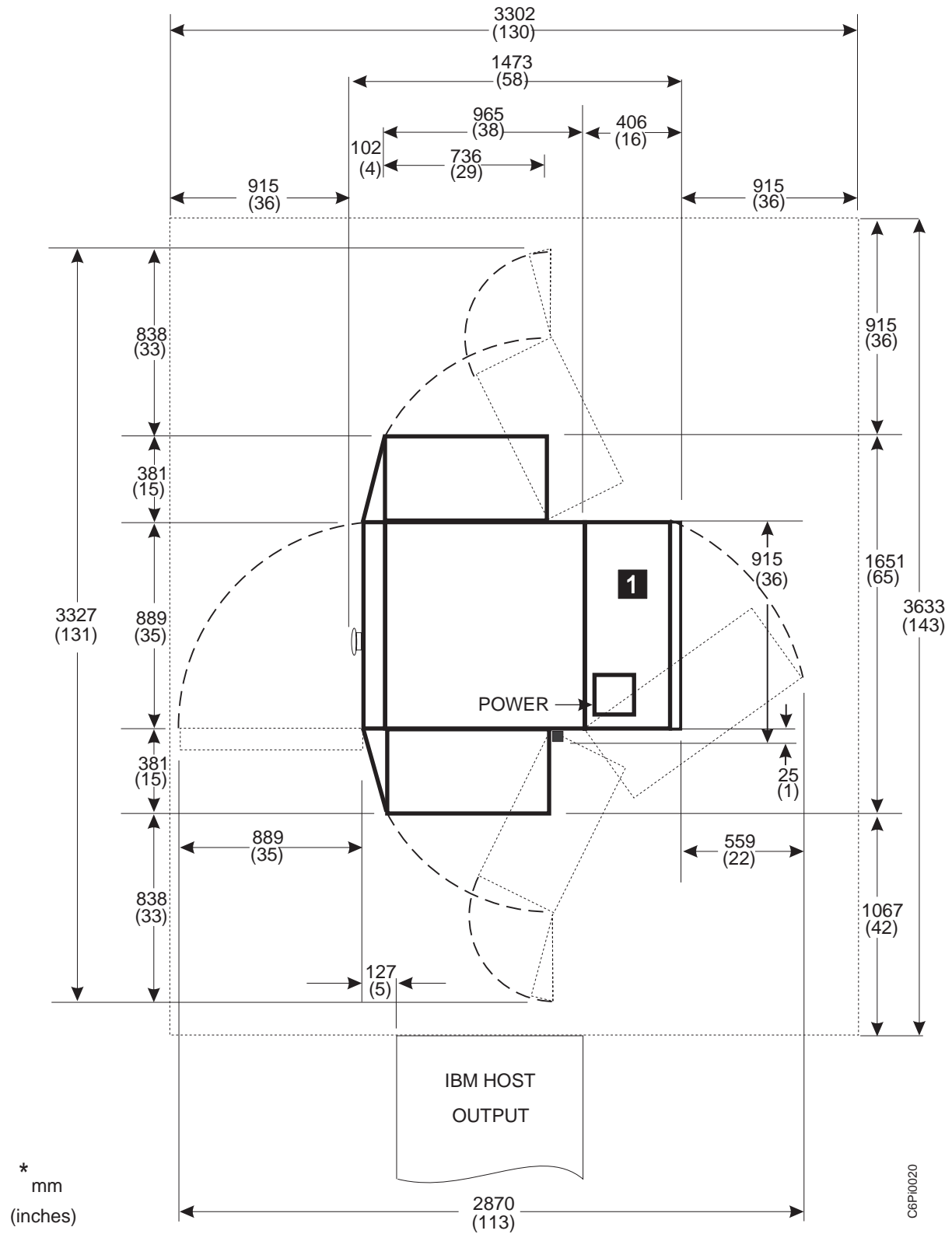

Figure 5. Dimensions, Service Clearance, and Cable Locations.



---

## Paper Interface Between the Host Printer and HCPP

To operate correctly, the following rules must be followed when locating the HCPP in the forms path:

- The HCPP must be placed 3.5 feet from any device on its input. This distance is a straight line measured from the HCPP enclosure to the device. Possible devices could include the host printer, a walk-over, or a 90° flipper (host printer duplex configuration only).
- The paper input to HCPP must be fed directly from the host printer or from a roller mounted no higher than 53.34 mm (21 in) off the ground.
- IBM does not recommend that active devices such as postprocessors or urge units be placed in the forms path between the host printer and the HCPP.
- IBM does not recommend that passive devices be placed in the forms path between the host printer and the HCPP. The exceptions are straight-line walkovers and a 90° flipper unit (host printer duplex configuration only).

---

## Physical Attachment Requirements

The system programmer, the IBM installation planning representative, and the physical planner plan the SCSI and 4720 cable route between the HCPP and the host printer. The SCSI and 4720 cables attach to the HCPP at **1** in Figure 5 on page 22 .

The feature code 4720 “Advanced Function Post-Processor Interface Feature”, cable supplied with the HCPP, must be ordered separately and installed on the host printer. It is used by the host printer and HCPP to maintain status between the devices. In a duplex host printer configuration, the 4720 cable attaches to the host printer which contains the feature code 4720 card. This is usually the printer which the HCPP follows.

The SCSI interface, cable supplied with the HCPP, connects the host printer to the HCPP. It is used by the host printer to pass the color information to the HCPP. In a duplex host printer configuration, the SCSI cable attaches to the printer utility module of printer 1.

Be sure to check that cables for additional postprocessors will be long enough once the HCPP has been installed.

---

## Installation Requirements

A service representative will install the HCPP and host printer. However, you are responsible for the following pre-installation tasks:

- Ensure that the environmental, electrical, and space requirements specified in this chapter are met. Use the “Installation Planning Work Sheet” on page 24 to complete this step.
- Work with your IBM marketing representative to ensure that a forklift and operator are available at delivery to remove the HCPP from its shipping pallet. After the HCPP is removed from the shipping pallet, you can move it on its own casters to the desired location.

**Notes:**

1. After your HCPP arrives, unpack it and check for external damage. If the covers are broken, bent, or scratched, work with the shipping contractor and your IBM marketing representative to resolve the problem.
  2. The forklift must have forks at least 91.5 cm (36 in) long and be capable of lifting 953 kg (2100 lbs).
- Inspect the receiving area and the areas through which the HCPP must be moved. Ensure that no obstacles interfere with moving the HCPP to its planned location. Consider the following:
    - The forklift needs space in which to operate.
    - Halls and doorways must be large enough for the printer to pass through (see Table 5 on page 21).
    - Hall corners and angles must be large enough to permit the forklift and printer to turn. If size is a problem see your IBM marketing representative.
    - Ramps must have no more than 8° incline.
    - Elevators and elevator doorways must be able to accommodate the size and weight of the HCPP and the people who are moving it.
    - Stairs, door sills, floor gaps, and carpeting can make it impossible to roll the HCPP.
  - Ensure that the floor is level within  $\pm 1^\circ$ .
  - Ensure that approved electrical outlets with correct power are reserved for the HCPP, and that they can be reached with the power cables.
  - If you are installing the HCPP on a raised floor, ensure that the access holes in the raised floor are large enough for the power cable.

---

## Installation Planning Work Sheet

Before your HCPP is delivered, prepare a site installation plan. Use the work sheet in Table 7 to ensure that all of the pre-installation requirements are met.

*Table 6. HCPP Installation Planning Work Sheet*

Requirements	Meets Requirements:	Needs Attention:	Assigned to:	Date Due:	Date Completed:
<b>Environmental</b>					
Ventilation					
Temperature					
Relative humidity					
<b>Space</b>					
Layout					
Storage space for supplies					
Clearances					
Delivery route					
Forklift <ul style="list-style-type: none"> <li>• Forks 91.5 cm (36 in)</li> <li>• Lifting 953 kg (2100 lbs)</li> </ul>					

Table 6. HCPP Installation Planning Work Sheet (continued)

Requirements	Meets Requirements:	Needs Attention:	Assigned to:	Date Due:	Date Completed:
<b>Electrical</b>					
Voltage					
Outlets:					
Can be reached by cables?					
Correctly grounded?					
Building branch circuit:					
Correctly grounded?					
Enough power to meet needs?					
Meets local and national codes?					
<b>Host Printer Attachment</b>					
SCSI cable route					
4720 cable route					

## Physical Planning Work Sheet

The physical planner:

- Identifies the location for the HCPP when the system is ordered
- Plans the electrical wiring and outlet requirements
- Schedules installing and testing of the electrical wiring and outlets before the HCPP arrives.

Use Table 7 as a work sheet when preparing the site for the HCPP.

Table 7. HCPP Physical Planning Work Sheet

Weeks before Delivery	Task	Assigned to:	Scheduled Completion Date:
15	<ol style="list-style-type: none"> <li>1. Identify the location for the HCPP and arrange for any necessary changes to the site</li> <li>2. Identify a delivery route to the location of the HCPP.</li> <li>3. Prepare a layout plan.</li> <li>4. Determine the requirements for electrical outlets</li> </ol>		
10	<ol style="list-style-type: none"> <li>1. Schedule installation of electrical wiring and outlets.</li> </ol>		
6	<ol style="list-style-type: none"> <li>1. Ensure electrical wiring and outlets are on schedule.</li> <li>2. Review site-preparation progress with IBM representative.</li> </ol>		

Table 7. HCPP Physical Planning Work Sheet (continued)

<b>Weeks before Delivery</b>	<b>Task</b>	<b>Assigned to:</b>	<b>Scheduled Completion Date:</b>
4	<ol style="list-style-type: none"> <li>1. Complete testing of electrical wiring and outlets.</li> <li>2. Complete site preparation.</li> <li>3. Verify forklift availability (see "Installation Requirements" on page 23 ).</li> </ol>		
Arrival	<ol style="list-style-type: none"> <li>1. Contact service representative for installation.</li> <li>2. Unpack the printer and inspect it for external damage.</li> <li>3. Move the printer to the prepared site.</li> </ol>		

---

## Chapter 4. Software Requirements for Printing Highlight Color Information

Some Advanced Function Presentation (AFP) licensed programs are required for printing highlight color information using the host printer and HCPP; others are optional.

---

### Required IBM Software

Support for highlight color requires Print Services Facility (PSF) licensed programs on each operating system using the host printer and the HCPP. The following are the PSF Licensed Program Numbers for each supported operating system:

- PSF/VM: 5684-141 version 2.1.1 or later.
- PSF/MVS: 5695-040 version 2.2.0 or later.
- PSF/VSE: 5686-040 version 2.2.1 or later.
- PSF/AIX: 5765-505 version 2.1 or later.
- PSF/400: 5716-SS1 version 3.7 or later.

All of the application and system support for HCPP printing will not be available for all operating systems. You should verify your intended application with your IBM marketing representative.

---

### Optional AFP Software

The planning team should work with the customer to determine which optional advanced functions are needed.

The following are some of the optional AFP licensed programs:

- Page Printer Formatting Aid (PPFA) for S/390, or the PPFA feature of AFP print suite for AS/400.
- Overlay Generation Language (OGL).
- AFP Toolbox for MVS, OS/400, AIX or OS/2.
- The Document Composition Facility (DCF) is a text-processing program you can use to create large, complex printed documents.
- The Overlay Generation Language (OGL) is a batch program you can use to create and modify electronic versions of your pre-printed forms. These electronic versions are called overlays.
- Page Printer Formatting Aid (PPFA) is a batch program you can use to create form definitions and page definitions.
- Image Sciences, Inc., Dallas, Texas, provides electronic document publishing and archival software solutions for numerous industries including banking, finance, insurance, transportation and utilities using DocuMerge and DocuGraph products.
- ELIXIR Technologies Corporation is an IBM business partner.
- M & I Data Services' CSF software solution allows organizations to create highly-personalized customer publications. The software uses a PC front end to visually display the publication as it is created.
- Group 1's DOC1 is a multi-platform, dynamic document composition system that lets you customize routine business documents, such as telephone bills, credit card statements, medical bills, direct marketing communications and other correspondence.

- Document software products from ISIS Information Systems provides support for a variety of application types, from line data formatting to fully composed AFP documents.

For information on other IBM business partners, contact your IBM marketing representative.

---

## Required Program Updates

In addition to the above software, some program updates PTFs (Program Temporary Fix) may be required for PSF and your optional IBM AFP software.

Call 1-800-IBM-SERV to determine and order the PTFs needed for your IBM licensed programs.

---

## New AFP Color Support Technical Reference

A description of the new AFP color support can be found in *InfoPrint Hi-Lite Color Application Design Guide*. This reference describes the programming techniques required to add highlight color to new or existing documents.

## Chapter 5. Application Development Guidelines

The information contained within this chapter describes the programming techniques required to design new highlight color applications or to add highlight color to existing applications.

### Available Highlight Color Coverage on the Form

The HCPP uses eight inkjet printheads to place color on the printed form. Each printhead is mounted on its own printhead carriage assembly. Before a print job is run, the printheads are moved to predefined positions on the printhead carriage assembly. The areas of the form passing under printheads, can be printed in highlight color. (See Figure 6.)

**Note:** Printing bar codes with the HCPP is not recommended.

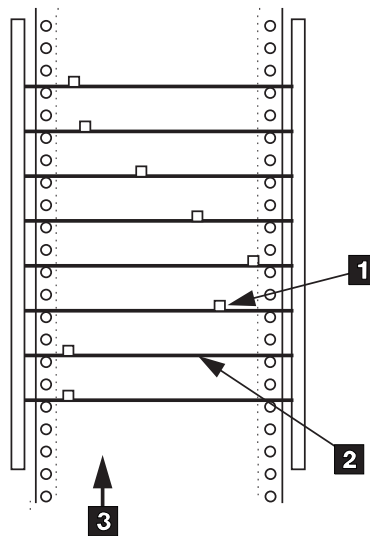

C6PI0001

Figure 6. Printhead carriage assemblies and printheads

- 1 Movable Print Head
- 2 Print Head Carriage Assembly
- 3 Direction of Paper Motion

Printhead locations for a print job are chosen so that all color pels contained in the print job can be printed. Figure 7 on page 30 shows a single printhead, and the shaded area shows the color coverage area made possible by the printhead's current location. The location (L) of the first jet of the printhead from the left edge of the form defines the location of all the printhead jets. Each printhead is made up of 256 inkjets at a resolution of 240 pels per inch which defines an area 1.06 inch wide (6.3 picas or 76.3 points). Any pels within this coverage area can be printed in color.

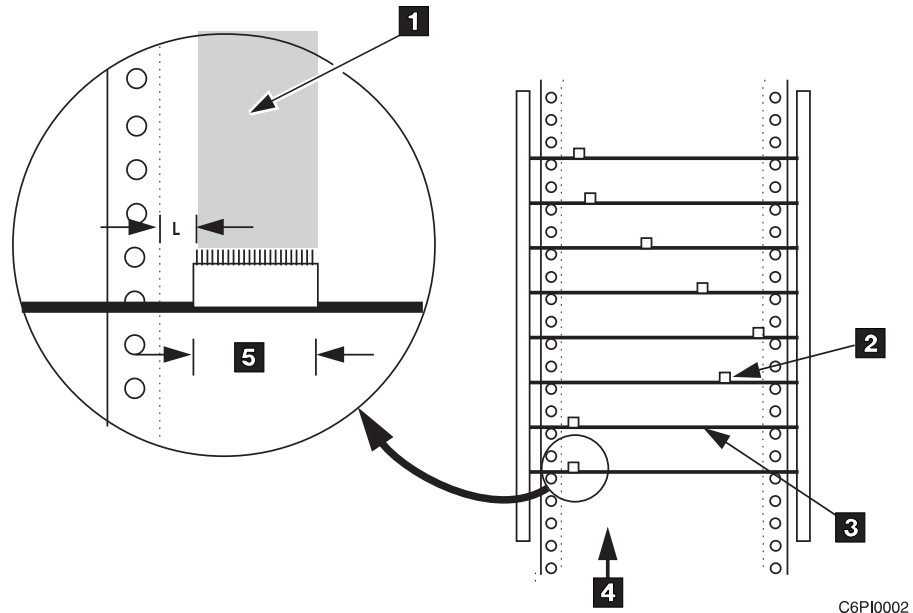

C6PI0002

Figure 7. Printhead coverage area

- 1 Coverage Area Shown Shaded
- 2 Movable Print Head
- 3 Print Head Carriage Assembly
- 4 Direction of Paper Motion
- 5 1.06 inch equals 256 ink jets at 240 pels/inch

Printheads can be positioned such that their coverage areas abut one another (this is called stitching printheads together). In this way, text or images requiring more than 256 pels in width can be printed. (See Figure 8.)

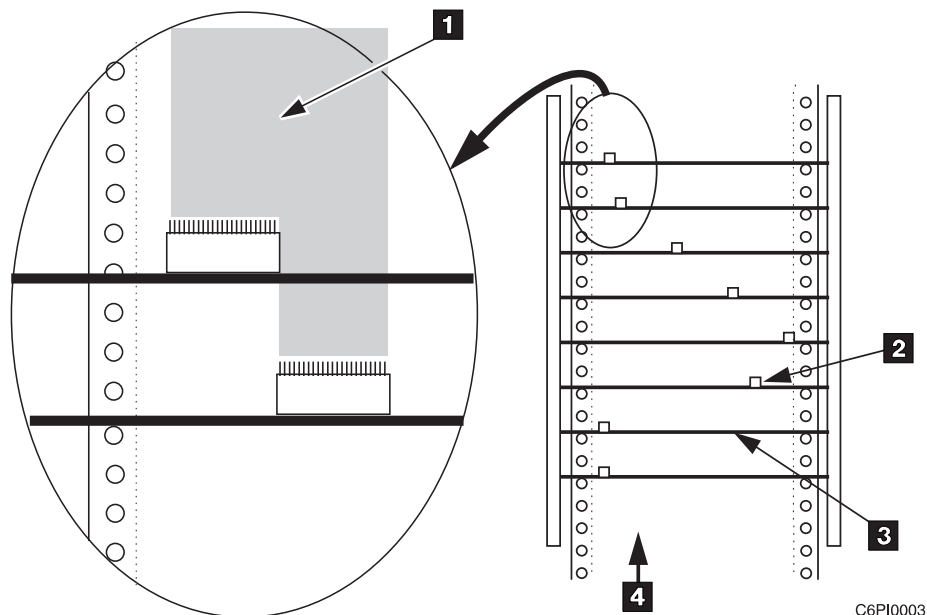

C6PI0003

Figure 8. Abutted printhead coverage areas



- 1 Coverage Area Shown Shaded
- 2 Movable Print Head
- 3 Print Head Carriage Assembly
- 4 Direction of Paper Motion

Each printhead is capable of printing one color of ink. The printhead coverage area can be overlapped by another printhead of a different highlight color so that multiple-color images can be printed. (See Figure 9.)

**Note:** The HCPP does not enable color mixing. Each pel in the data stream can be rendered by only one printhead.

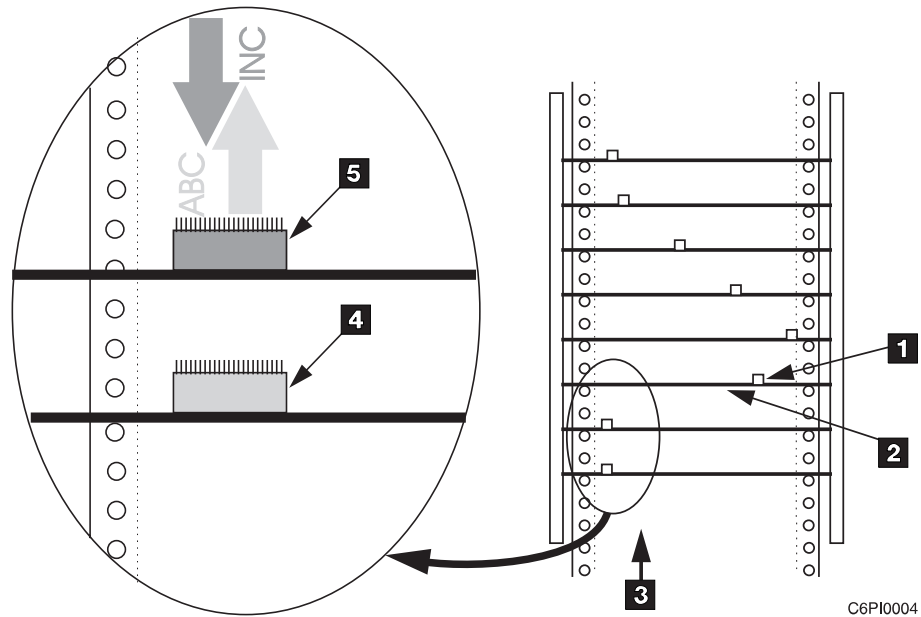

Figure 9. Overlapped coverage areas

- 1 Movable Print Head
- 2 Print Head Carriage Assembly
- 3 Direction of Paper Motion
- 4 Ink Color 2
- 5 Ink Color 1

Before a print job is initiated, printheads are automatically moved to the printhead locations for that print job. Printhead locations remain fixed for the duration of the print job. After the print job completes, the printheads can be moved to new locations for the next print job.

Any text, image, or graphical elements must be within the coverage area of a printhead or group of printheads in order to be printed in color. A print job designed for portrait orientation may not print correctly if the print job is changed to landscape orientation. In Figure 10 on page 32, the change in orientation of the print job has made the corporate logo unprintable with the current locations of the two printheads shown.

Orientation must be a consideration when the application is designed. An application designed to print in one orientation with respect to the form movement,

cannot necessarily be changed to print in another orientation due to the limitations of the HCPP printhead coverage in a different direction.

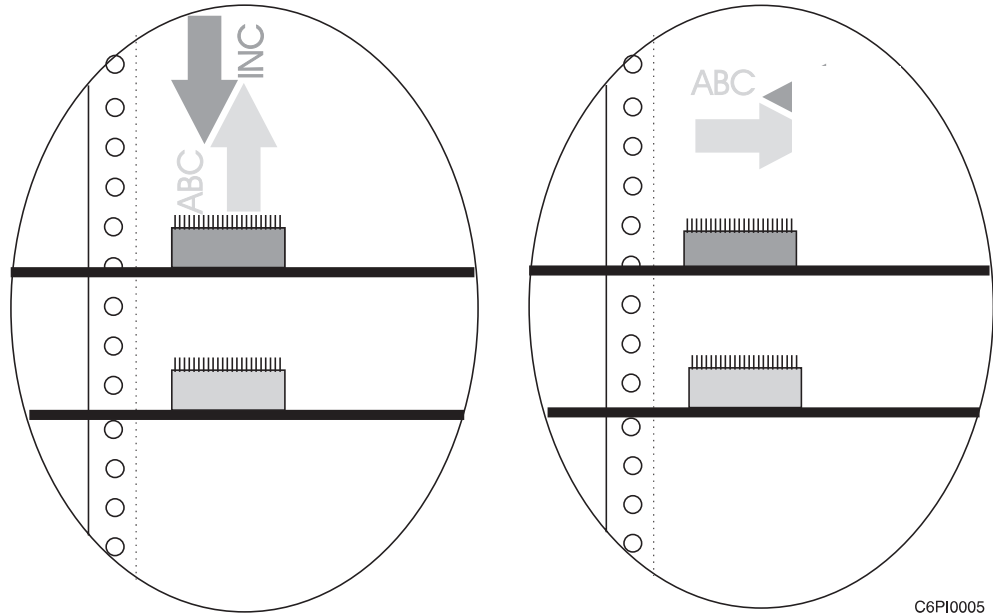

C6PI0005

Figure 10. Printheads and Form Orientation

Collectively, all the printhead locations necessary to print a job are part of the job setup. The job setup tells the HCPP where to move the printheads, and what ink colors are required. The job setup information is entered into permanent storage on HCPP. Every time that job is run, the HCPP uses the setup information recalled from permanent storage. See “Setup Concepts” on page 37 for more information.

## Ink Color Availability

A standard HCPP configuration contains one ink reservoir assembly which contains four partitioned ink reservoirs. Each ink reservoir can contain a different color. An additional ink reservoir assembly can be ordered which accommodates four ink reservoirs for a total of eight ink reservoirs within the system enclosure.

Ink is supplied to the printheads through heated umbilicals running from the reservoirs. Each reservoir can supply ink to as many as four printheads.

Once a printhead has been used for a specific ink color, the printhead remains dedicated to that ink color for the life of the printhead.

Ink colors are ordered from a palette of standard colors. Custom colors can also be designed and ordered.

## Highlight Color Availability

The implementation of highlight color in AFP allows each element on a form to be rendered in black, or in any one of three AFP highlight colors. The HCPP job Setup is designed so that the AFP highlight colors, used in the data stream, are mapped to the specific ink colors needed for that print job. The setup for the next print job may assign the three AFP highlight colors to different ink colors.

## Example of Highlight Color Application

The following corporate invoice example uses seven of the eight available printheads to add color: Figure 11 shows the output from the host printer (which is the input to the HCPP), Figure 12 on page 34 shows where the printheads (PH) are applying color to the corporate invoice, and Figure 13 on page 35 shows the output of the HCPP.

The invoice form is enclosed in a rectangular border with a series of small circles along the top and bottom edges, representing punch holes. The form contains the following information:

**Account Number:** PBR-004-78965  
**Invoice Date:** 11-7-95

**Return Payment To:**  
**Aussie Camping Supplies**  
 2 Coonara Avenue  
 Australia NSW 2125

**Bill To:**  
**Ernest & Jeanne Smallman**  
 3946 Johnson Ave.  
 Western Springs, IL 60521

Date	Product Number	Description	Amount
11-1-95	AH-945683	Arctic Heat Sleeping Bag	\$275.00
		State Tax (6%)	\$16.50
		Total Amount	\$291.50

**Sleeping Bag Pre-Heaters Now Available**  
 Call 1-800-ACS-CAMP

---

Account Number	Amount Due	Amount Paid	Due Date
PBR-004-78965			12-7-95

**FROM:**  
**Ernest & Jeanne Smallman**  
 3946 Johnson Ave.  
 Western Springs, IL 60521

**TO:**  
**Aussie Camping Supplies**  
 2 Coonara Avenue  
 Australia NSW 2125

A small square icon with the number '1' and an arrow pointing to the right is located on the right side of the form, indicating the direction of paper motion.

C6PI0009

Figure 11. HCPP input

1 Direction of paper motion

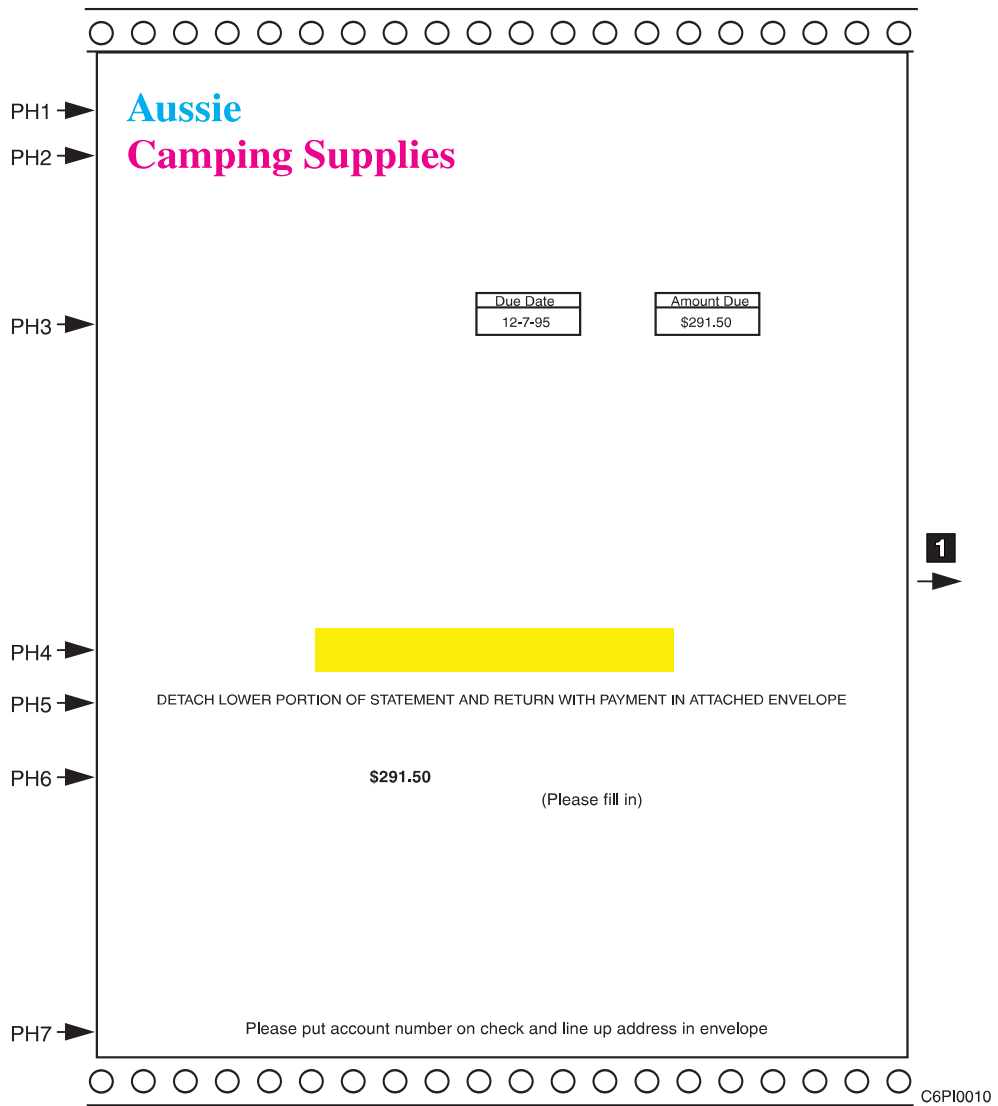

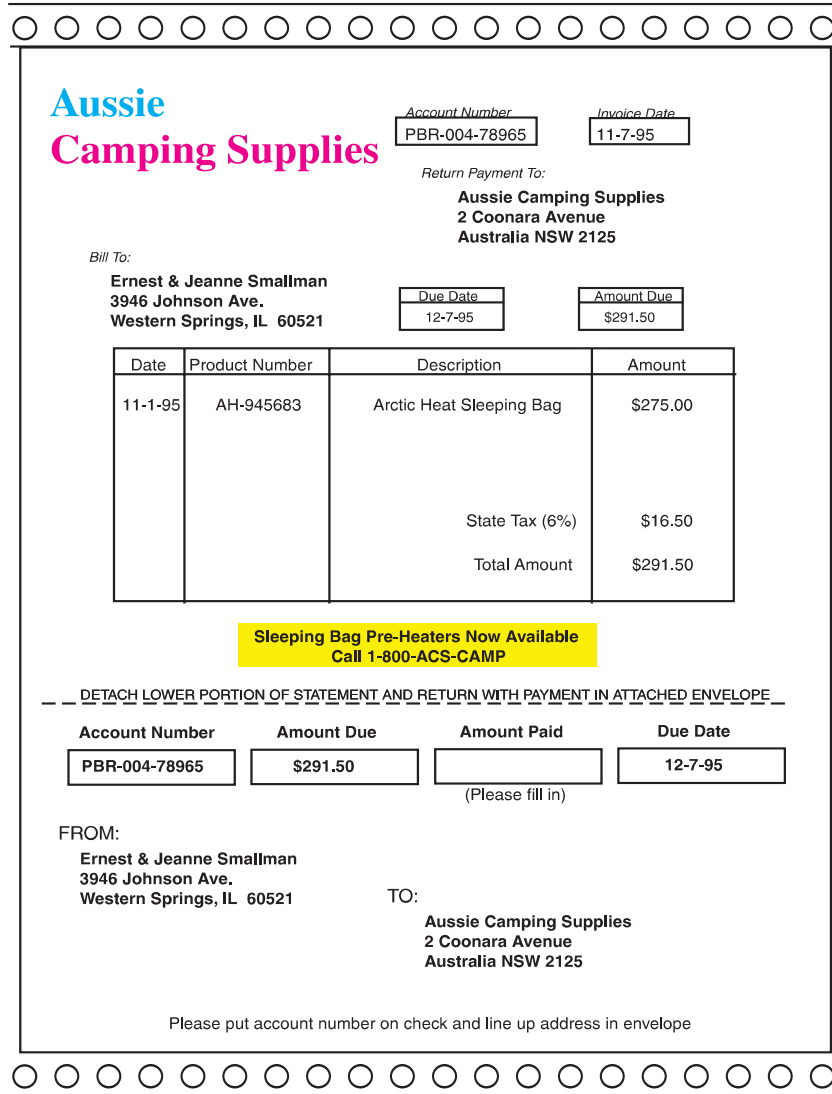

Figure 12. HCPP highlight color

 Direction of paper motion



C6PI0011

Figure 13. HCPP output

**1** Direction of paper motion

This example illustrates some of the uses of highlight color:

- Printheads 1 and 2 (PH1, PH2) print the corporate logo. Many companies are identified by their corporate colors.
- Printhead 3 (PH3) prints the amount due and the due date. Studies have indicated that some people pay their bills faster if this information is in color.
- Printhead 4 (PH4) prints a colored box over the sales message printed by the host printer causing it to stand out. This is very similar to the effect a highlighter pen has on the printed form.
- Printhead 5 (PH5) prints instructions to the customer. The color helps the selected information to stand out.
- Printhead 6 (PH6) prints the amount due, as well as additional instructions.
- Printhead 7 (PH7) prints more instructions to the customer.

**Note:** All seven printheads must be placed in position before the job is run. This application is designed to be printed in this form orientation only.

## Bitmaps

The AFCCU separates the color pels from the data stream and sends them to the HCPP in the form of a bitmap for each AFP highlight color. Each zero or one in the bitmap represents a pel which is turned off (zero, no ink) or turned on (one, ink). A bitmap can be conceptually overlaid on the form as shown in Figure 14.

A bitmap is a two-dimensional array of 0's and 1's. The origin (0,0) is the location where scan direction and process direction start. The term "scan direction" refers to movement perpendicular to the direction that the forms are moving through the HCPP. The term "process direction" refers to movement parallel to the direction that forms are moving through the HCPP.

Each bitmap sent to the HCPP is full size as shown in figure Figure 14. Bitmap 1 contains all zeroes except for the pels that are to be printed in Highlight color 1. Bitmap 2 contains all zeroes except for the pels that are to be printed in Highlight color 2. Bitmap 3 contains all zeroes except for the pels that are to be printed in Highlight color 3.

Bitmaps are sometimes referred to as pel maps or a raster image.

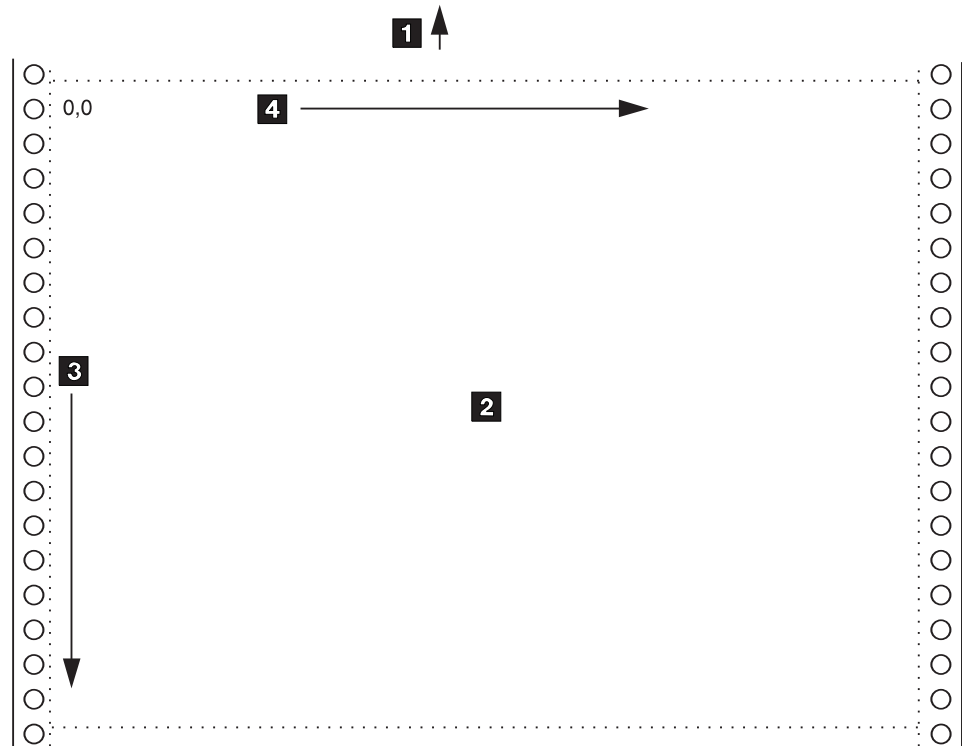

C6PI0013

Figure 14. Bitmap orientation

- 1 Direction of paper motion
- 2 Bitmap (pel map or raster image)
- 3 Process Direction
- 4 Scan Direction

## Setup Concepts

A setup defines information about how to print the print job. setup information is designed by the application developer and entered into permanent storage on the HCPP through the operator console. A setup specifies the locations of the printheads required for the job, and the ink colors that must be used.

**Setup Design Worksheet**

1 Setup Text Name: \_\_\_\_\_  Hide

2 Setup Verification ID: \_\_\_\_\_  
(two-byte hexadecimal ID)

3 Color Side: Color on Front  Color on Back

**Virtual Printheads**

4

Ink Color	AFP Highlight Color # (1, 2, or 3)	Location (in pels)	Width (in pels)

5 Prerequisite Setups:  
(Setup Verification ID's)

#1  #2  #3

6

C6PI0006

Figure 15. Setup Design Worksheet

A print job may require information from several setups in order to specify the locations of all printheads required to print the job. Before a job is run, the operator selects the required setups from the available setups stored in the HCPP. Once selected, the required setups are automatically “loaded” into the HCPP. “Loading” a setup means that printheads, with the appropriate colors, are automatically moved to the proper locations to print the job.

The form shown in Figure 15 can be used by the application developer to record setup information. After the worksheet is filled out, the information can be entered into HCPP permanent storage. The worksheet is identical to the form in “Appendix A. Setup Design Worksheet” on page 61 and the one that must be filled out on the Operator’s console of the HCPP. Once entered into permanent storage, this information is available whenever the job is printed. Each time the job is printed, the operator loads the setup (if it is not already loaded). A setup is described by the following items:

1. Setup Text Name **1**: Each setup has a unique text identifier assigned by the application developer. This text identifier is usually something that is recognizable to the operator. For example, 'Company Invoice'.
2. Setup Verification ID **2**: Each setup has a unique setup verification ID assigned by the application developer. This ID is a two-byte hexadecimal identifier from the range X'0000' to X'FFFF'. This setup ID is reported to the host so it can verify the proper setup before the job is started, in systems that support this function.
3. Color Side **3**: The color side can be set to Color on Front or Color on Back. Since the HCPP is a simplex device, color pels can be on only one side of the form during a print job. This parameter indicates whether highlight color pels are found on the front or the back of the form for print jobs using this setup.
4. Virtual Printheads **4**: Virtual printheads are unique (InkColor,Bitmap#,PHLocation,PHWidth) combinations for this setup. A (InkColor,Bitmap#,PHLocation,PHWidth) combination can be thought of as a requirement for color at a specific scan-direction location on the form. The virtual printhead that fulfills this color requirement has limited width in the scan direction (PHWidth), but can provide complete coverage in the process direction. So, each unique (InkColor,Bitmap#,PHLocation,PHWidth) combination defines a "virtual" printhead at a specific scan-direction location, with a specific width, with a specific ink color, and associated with a specific AFP highlight color bitmap, that will fulfill the color requirement (see Figure 16 on page 39).

**Note:** For the purposes of this document the following two terms are equivalent:

- Unique (InkColor,Bitmap#,PHLocation,PHWidth) combination
- Virtual Printhead

The term "virtual" is used because HCPP decides which specific physical printhead or printheads will be used to fulfill the color requirement of the virtual printhead. The HCPP will choose these specific physical printheads at the time that the setup is loaded. This decision is based on which physical printheads are available when the setup is loaded. The next time this setup is loaded, different physical printheads may be available and used.

A virtual printhead is defined by:

- InkColor: What ink color should be used in the virtual printhead.
- Bitmap#: The host application has a palette of three AFP highlight colors. Each of the three bitmaps sent by the host printer represents one of these unique AFP highlight colors; either Highlight Color 1, Highlight Color 2, or Highlight Color 3. Bitmap# specifies which of the three color bitmaps will be used to send pels to the virtual printhead to print. Only this bitmap will be searched for pels to print by this virtual printhead.
- PHLocation: This parameter specifies the scan-direction distance from the origin to the first jet of the virtual printhead.
- PHWidth: The width of the virtual printhead in pels (or jets). The HCPP automatically computes how many physical printheads are required based on the number of jets needed by the virtual printhead.



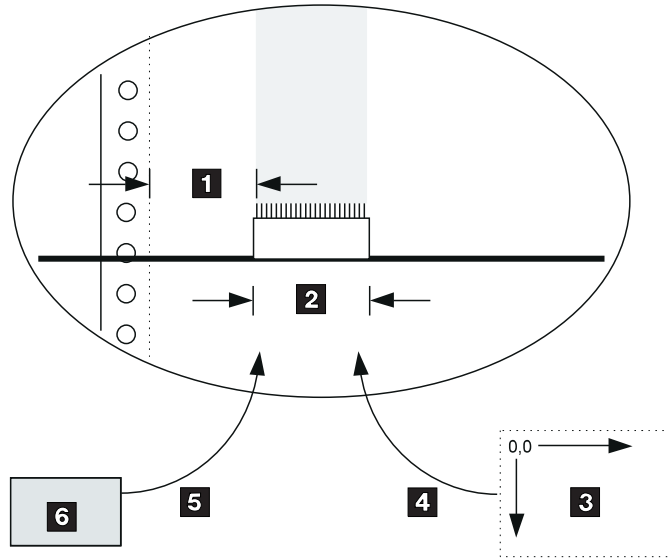

C6PI0015

Figure 16. Virtual printhead

- 1 PHLocation (in pels)
- 2 PHWidth (in pels)
- 3 AFP highlight color bitmap #N
- 4 BitMap# N pels sent to Virtual Printhead for printing
- 5 Tube carrying ink color to virtual printhead
- 6 Reservoir containing ink color

Virtual printhead locations and widths are entered in pels. There can be as many as eight unique (InkColor,Bitmap#,PHLocation,PHWidth) combinations specified for a setup.

“InkColor” is the same number located on the packaging of the ink blocks for the color. This number is “ACSxxxx” where xxxx is a unique identification number for the ink color.

5. Prerequisite setups (P-Setup) 5: A setup may also specify previously defined setups as being P-Setups. The HCPP adds the (InkColor,Bitmap#,PHLocation,PHWidth) combinations defined by the P-Setup to the unique (InkColor,Bitmap#,PHLocation,PHWidth) combinations defined by the Setup to determine the total resources required to load the setup.

The unique setup verification ID associated with a P-Setup is reported to the host along with the unique setup verification ID associated with the setup. (See discussion below concerning reporting setup verification IDs to the host.)

All other information associated with the P-Setup, including text field identifier, Print Adjust Corrections, and Color Side setting, is ignored while this setup is being used as a P-Setup.

**Note:** A setup cannot be used as a P-Setup if it references additional P-Setups.

6. Hide 6: Operators load setups from a list displaying setup verification IDs and text names. The application developer can prevent a setup from appearing in this list by checking this box. A hidden setup only appears to key operators.

7. **Print Adjust Corrections:** Each setup may also have print adjust corrections associated with it. Print adjust corrections are minor corrections made to the predefined printhead locations by an operator to improve the appearance of the printed output. These print adjust corrections are applied to the specific physical printheads that HCPP uses to fulfill the color requirement at the time the setup is loaded.

**Note:** These print adjust corrections are the only part of the setup that is not defined by the application developer.

No unique (InkColor,Bitmap#,PHLocation,PHWidth) combinations need to be defined for a setup. The setup can be made up entirely of P-Setups. However, a setup and its P-Setups taken together must define at least one (InkColor,Bitmap#,PHLocation,PHWidth) combination.

---

## Loading Setups

Multiple setups may be loaded into the HCPP concurrently, but setups must be loaded one at a time and have the same Color Side setting.

When a setup is selected, all unique (InkColor,Bitmap#,PHLocation,PHWidth) combinations for the new setup are compared against available ink colors and physical printheads, and against currently loaded setups. Physical printheads are assigned to the setup from the set of available physical printheads.

Two concurrently loaded setups may not share physical printheads. The HCPP ensures that each physical printhead is assigned to one and only one setup at a time.

If a conflict exists, or if the (InkColor,Bitmap#,PHLocation,PHWidth) combinations for the new setup cannot be fulfilled with the colors and printheads currently available, the operator will be notified.

The following conditions could result in an inability to load the setup:

- Currently loaded setups look for color on the other side of the form from the setup trying to be loaded.
- The proper ink colors are not available in the HCPP
- Physical printheads with the correct ink color are not available.

The HCPP reports to the operator that the setup cannot be loaded, and suggest what actions can be taken to setup correctly (such as removing a currently loaded setup, changing a printhead, and the like).

**Note:** Setups can only be changed between print jobs. Before changing setups, the HCPP operator is prompted to move all remaining pages from the previous print job completely through all the post-processors by performing an NPRO (Non Process Run-Out). If this is not done, the forms remaining between the host printer and HCPP would be unprintable and generate errors.

---

## An Example Using Prerequisite and Hidden Setups

The following example demonstrates some of the flexibility that you have in defining setups.

Company XYZ prints numerous forms. Each form always contains the company logo in the same position but in two possible sizes. A custom ink color is used for this logo. Developers for XYZ defined two setups for printing company logos: “Logo1” which uses a virtual printhead of the smaller size, and “Logo2” which uses a virtual printhead of the larger size. All setups designed by XYZ call out either “Logo1” or “Logo2” as a P-Setup.

In order to prevent confusion, “Logo1” and “Logo2” are “hidden” from the operator setup selection list. These two setups are only intended to be used as P-Setups.

---

## System Level Setup Verification

Two levels of system-level controls are supported to allow customers to ensure that the HCPP print heads are positioned correctly and that the proper inks are loaded.

1. The first level of verification involves the system operator who conditionally releases jobs for print only when the HCPP is properly configured. The implementation of this support is platform-dependent. For example:
  - PSF/MVS: The configuration is encoded as a forms ID. The form is specified in the print request, causing a message to appear on the system operator console to ensure that this form has been loaded (the particular configuration has been set up). The job is not released for print until the system operator replies that the form is loaded, that is that the HCPP is set up with the defined configuration.
  - PSF/6000: All jobs requiring a particular HCPP setup are routed to a specific queue. This queue is not released for print until the operator has checked that the required HCPP setup has been loaded.
  - PSF/400: The configuration is encoded as a forms ID. When the Writer is started, a message is generated on the console to ensure that the proper form is loaded. The job submitter or person running the writers must reply affirmatively before the job can be printed.

**Note:** This level of verification relies solely on the system operator, who may be located far from the HCPP and who may not understand all of the print issues. See the PSF documentation for more information on this method of setup verification.

2. The second level of setup verification is more rigorous and involves the FormDef, the print server, the HCPP, and the printer operator.

Keywords in the Medium Map of a FormDef are used to specify the setup verification IDs required for the job. Multiple IDs can be specified. Before the job is submitted for print with this FormDef, the printer operator ensures that the correct HCPP setups are loaded.

The print job is submitted with the FormDef that specifies the required setup verification IDs. When PSF processes the print job with the FormDef, it queries the printer for the setup verification IDs that are currently loaded and compares them against the IDs specified in the FormDef. If all setup verification IDs specified in the FormDef are loaded in the HCPP, the job is allowed to print. If one or more of the required setup verification IDs is not loaded, or if the printer does not support reporting of setup verification IDs, the job is held. A message is sent to the system operator specifying that the proper setup is not present.

**Note:** An installation can use method (1), or method (2), or both (1) and (2) to ensure that the print job is run only when the proper HCPP setups are loaded. The second level of verification is not available in all operating systems. Contact IBM Software Service for availability of this support.

## Setup Verification Process

Figure 17 illustrates the second level of Setup Verification process described above for systems that support this feature.

1. The application developer designs the application and the Setups required to print the job. The setup information is entered into permanent storage on the HCPP through the operator's console. Each setup has a text name and a two-byte setup verification ID assigned by the application developer.
2. Before the print job is run, the operator loads the proper setup in the HCPP by selecting the setup text name from a list of all available stored Setups. This step is performed each time a print job is run, unless the proper setups are already loaded.
3. When the operator loads the setups, the HCPP moves the printheads with the proper colors to the positions specified by the Setup.
4. The HCPP transmits the two-byte setup verification ID's for all currently loaded setups to the host printer. The host printer in turn transmits these ID's to PSF when requested.
5. When the print job is submitted for printing, it contains a list of all the setup verification ID's required, in the FormDef, for the print job. PSF compares the setup verification ID's in the FormDef to the list of setup verification ID's currently loaded in the HCPP. If all the setup verification ID's are loaded, the job is submitted for printing. If not, the job is held.

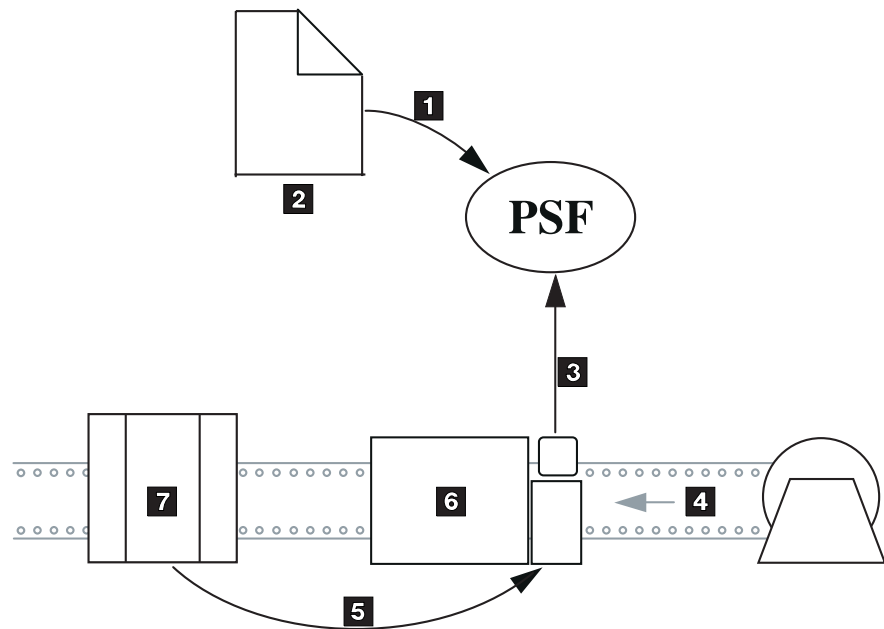

C6PI0012

Figure 17. Second Level of System Setup Verification

- 1 Needed Setup Verification ID's from FormDef reported to PSF
- 2 Print job containing FormDef
- 3 Currently loaded setup verification ID's reported to PSF
- 4 Forms
- 5 Currently loaded setup verification ID's reported to host printer
- 6 Host printer

## Verifying the Setup ID from an MVS Host

Keywords in the Medium Map (Copy Group) of a Form Definition are used to specify the setup verification IDs required for a job. Multiple IDs can be specified. Form Definitions are usually created using a program such as IBM's Page Printer Formatting Aid (PPFA). For more information, see the *PPFA User's Guide*, S544–5284.

For applications that generate their own Form Definitions, the setup verification ID is specified in the Medium Modification Control (MMC) structured field. The following is an example of the architecture syntax for setup verification.

Keywords in the Medium Map of a FormDef are used to specify the setup verification IDs required for the job. Multiple IDs can be specified. The keyword is specified on the Medium Modification Control (MMC) (see *Data Stream and Object Architectures Mixed Object Document Content Architecture Reference*) structured field in the FormDef and the following is an example of the syntax and semantics:

Table 8. MMC (X'D3A788') Syntax

Structured Field Introducer						
SF Length (2B)	ID = X'D3A788'	Flags (1 B)	Reserved; X'0000'	Structured Field Data		
Offset	Type	Name	Range	Meaning	m/O	Exec
0	CODE	MMCID	1-127	Medium Modification Control identifier	M	X'06'
1	CODE		X'FF'	Constant data	M	X'06'
0 or more keywords in ascending order in the following format. When keywords occur in pairs, the ordering is applied to the first keyword.						
Offset	Type	Keyword ID	Range	Meaning	M/O	Exec
		X'B4'	X'00 - FF'	Presentation subsystem setup ID: high-order byte	O	X'02'
		X'B5'	X'00 - FF'	Presentation subsystem setup ID: low-order byte	O	X'02'

### MMC Semantics

- MMCID (Medium Modification Control Identifier)
- Keyword

### MMCID

The identifier for the modifications specified by this structured field. This identifier is specified in a repeating group in the Medium Copy Control (MCC) structured field.

### Keyword X'B4nn'

Specifies the high-order portion of a two-byte presentation subsystem setup ID. The allowed range is X'00'–X'FF'. This keyword must be paired with a X'B5nn' keyword that immediately follows it and that specifies the low-order portion of the two-byte

presentation subsystem setup ID. The X'B4nn'-X'B5nn' keyword pair may appear multiple times. If the keyword pair is not present, a presentation subsystem setup ID is not specified. The setup ID specified by the X'B4nn' and X'B5nn' keywords is compared against the setup verification IDs generated by the presentation subsystem, which typically consists of the presentation device and pre/post-processing devices. If a match is found, presentation is allowed to proceed. If there is no match, the required setup is not active in the presentation subsystem and the presentation is held.

### **Keyword X'B5nn'**

Specifies the low-order portion of a two-byte presentation subsystem setup ID. The allowed range is X'00'–X'FF'. This keyword must be paired with a X'B4nn' keyword that immediately proceeds it and that specifies the high-order portion of the two-byte presentation subsystem setup ID. The X'B4nn'-X'B5nn' keyword pair may appear multiple times. If the keyword pair is not present, a presentation subsystem setup ID is not specified. The setup ID specified by the X'B4nn' and X'B5nn' keywords is compared against the setup verification IDs generated by the presentation subsystem, which typically consists of the presentation device and pre/post-processing devices. If a match is found, presentation is allowed to proceed. If there is no match, the required set up is not active in the presentation subsystem and the presentation is held.

All Medium Modification Control structured fields in a Medium Map must specify the same presentation subsystem setup IDs. Since Presentation Subsystem setup IDs are intended to be specified for one or more documents in a print file, the same IDs should be specified in all the Medium Maps in the Form Definition.

For more information see *InfoPrint Hi-Lite Color Application Design Guide*. For a complete definition of Form Definitions, Medium Maps, and MMC structured fields, see *Mixed Object Document Content Architecture Reference*, SC31-6802.

---

## **Placing Color on the Correct Side of the Form**

When HCPP is used with a duplex host printer, care must be taken to ensure that the color is printed on the correct side of the form. The application programmer who designs the application, as well as the operator who runs the print job, both have a hand in assuring that the job prints correctly.

The following information is helpful for the discussion that follows:

- The HCPP prints color on one side of the form. Color is printed on the side of the form (paper) that faces up when the form enters the HCPP enclosure.
- Print jobs intended for the HCPP have color pels in the printer data stream. The AFCCU looks for color pels on one side of the form only. Only color pels on the specified side of the form are sent to the HCPP for printing.
- The operator on the HCPP must set all host printer and HCPP configuration parameters such that color pels are printed on the correct side of the form.

After the operator on HCPP loads a new setup, HCPP touchscreen instructions may be given to the operator to ensure that all configuration parameters are set correctly in the host printer and HCPP. When these parameters are set correctly, the color pels are printed on the correct side of the form by the HCPP.

## Loading Forms Correctly in a Host Printer Simplex Configuration

In a host printer simplex configuration, color is always assumed to be on the front of the form regardless of the color side setting specified in the setups. Setups with conflicting color side settings can be loaded concurrently. No configuration parameters need to be changed when loading setups.

**Note:** The Buffer/Flipper (see Figure 19 on page 46) or 90° flipper (see Figure 18 on page 46 ) are not supported between the host printer and HCPP in a host printer simplex configuration.

## Loading Forms Correctly in a Host Printer Duplex Configuration.

In a host printer duplex configuration, there are several parameters which need to be set correctly to assure that color prints on the correct side of the form.

Host printer Configuration Parameters:

- **Front Sheet Sequence:** Values are Front First or Front Second. This parameter sets whether the front side of the form is printed on Printer 1 or Printer 2. Front First means that side one of the form is printed on Printer 1 and that side two is printed on Printer 2. Front Second means the opposite.
- **Color Side:** Values are Color on Front and Color on Back. This parameter specifies on which side of the form the AFCCU renders color. Color on Front means that the AFCCU renders color pels found on the front (side one). Color on Back means the AFCCU renders color pels found on the back (side two). Color found on the wrong side of the form is rendered as black except for object area fill, which is rendered as color of medium.

**Note:** For forms to be loaded correctly, the color side value on the host printer must always match its equivalent HCPP parameter as specified by the setups currently loaded in the HCPP.

The above configuration parameters are set depending on whether a 90° flipper exists between Printer 2 and the HCPP. A 90° flipper is usually used when space constraints prevent a "straight paper path". The use of 90° flippers between the host printer duplex system and the HCPP is supported by IBM.

A 90° flipper inverts the paper 180° while changing the direction of paper motion by 90°. See Figure 18 on page 46.

**Note:** The flipper should be obtained from the post-processor vendor. No flipper (see Figure 18 on page 46) is provided with the HCPP.

The Buffer/Flipper Unit inverts the paper 180° while keeping the direction of paper motion constant. See Figure 19 on page 46.

**Note:** IBM does **NOT** support the use of a Buffer/Flipper unit between the host printer duplex system and the HCPP.

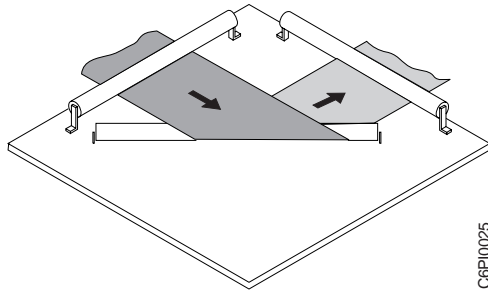

C6P10025

Figure 18. 90° Flipper

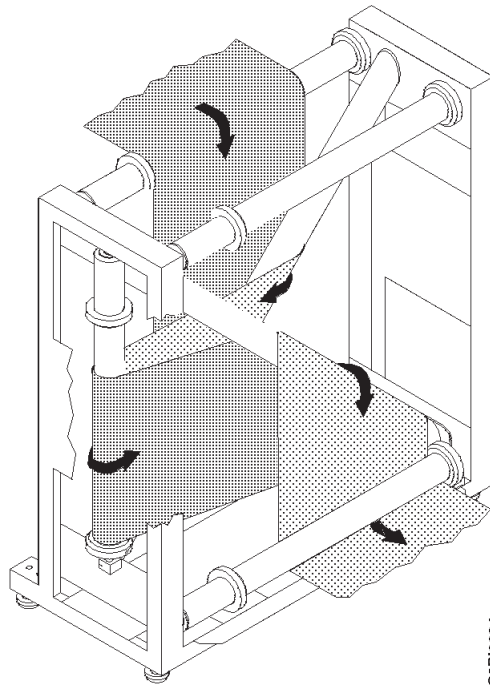

C6P10024

Figure 19. Buffer/Flipper-Straight Line

In a host printer duplex environment, whenever new setups are loaded into the HCPP, which have a different color side setting from the previously loaded setups, the HCPP instructs the operator how to set the host printer Color Side and Front Sheet Sequence parameters correctly.

## Verification of Color on the Correct Side of the Form

The HCPP provides two methodologies for verification that the forms have been loaded correctly. The host printer can be configured to stop automatically a specified number of feet after a forms jam has been cleared to allow the operator to verify that the color is being printed on the correct side of the form. Additionally, the host printer can be configured to stop periodically to allow the operator to verify that the color is being printed on the correct side of the form.



---

## Registration

When designing highlight color applications, the placement accuracy with which bit maps are printed on the form is a consideration. This placement accuracy is called registration. There are two kinds of registration accuracy to consider for highlight color.

- Registration to the Edge of the Form
- Print Head Skew

### Registration to the Edge of the Form

Registration to the edge of the form defines the absolute registration of the printed pel map versus its ideal location on the form. The HCPP color pel map can be placed on the form with a certain registration accuracy. The host printer black pel map can be placed on the form with another registration accuracy.

Therefore, when considering the registration between host printer black pels and HCPP color pels, the application designer must leave room for a maximum additive registration variation between black and color pels on the printed form. This is probably not a large concern when printing colored text inside a black box where there is room for some placement variation. However, tighter registration is sometimes a requirement.

To accommodate tighter registration between black and color pels, the HCPP provides the following capabilities:

- Calibration and Print Adjust Procedures

The operator on the HCPP is capable of performing procedures to improve the registration between host printer black pels and HCPP color pels before the job is run. (See “Procedures to Improve Registration” on page 49.)

- Overspraying

Sometimes the HCPP ink is used to highlight black text printed by the host printer. This creates an effect similar to that achieved with a traditional highlighter pen.

This would normally present a registration problem since each pel in the data stream is only printed once. The color box sent to the HCPP for printing would, in theory, be missing the pels associated with the locations of the black text. This would require very tight registration between the two machines to make sure the black text “fits” inside the holes in the color box.

To accommodate this registration issue, the AFCCU builds a pel map that contains a solid color box. Additionally, the ink used in the HCPP is translucent to the host printer toner. Therefore, when the black text is printed on the host printer and is “oversprayed” with a solid color box, the host printer toner shows through, creating the appearance of perfect registration.

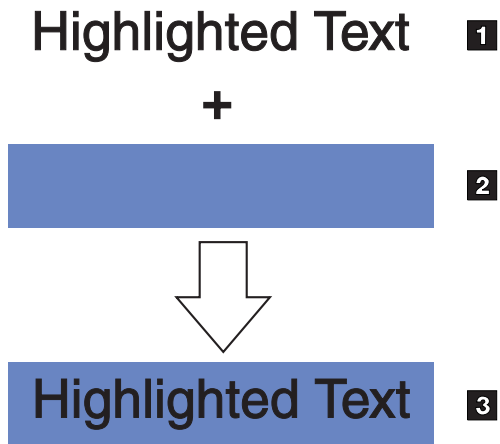

C6PI0022

Figure 20. Overspraying Highlight Text

- **1** Host printer output
- **2** HCPP oversprays with solid box
- **3** Final effect

Overspraying applies to any solid area sent to the AFCCU in the IPDS data stream (circles, ellipses, and the like). Another application of this technique is a solid color area with a black border. To assure that there are no “white spaces” between the color fill and the black border, the black border should be at least 10 pels thick. The color area fill should overlap this border by 5 pels. That way, even with registration variation, the color fills the whole area inside the border.

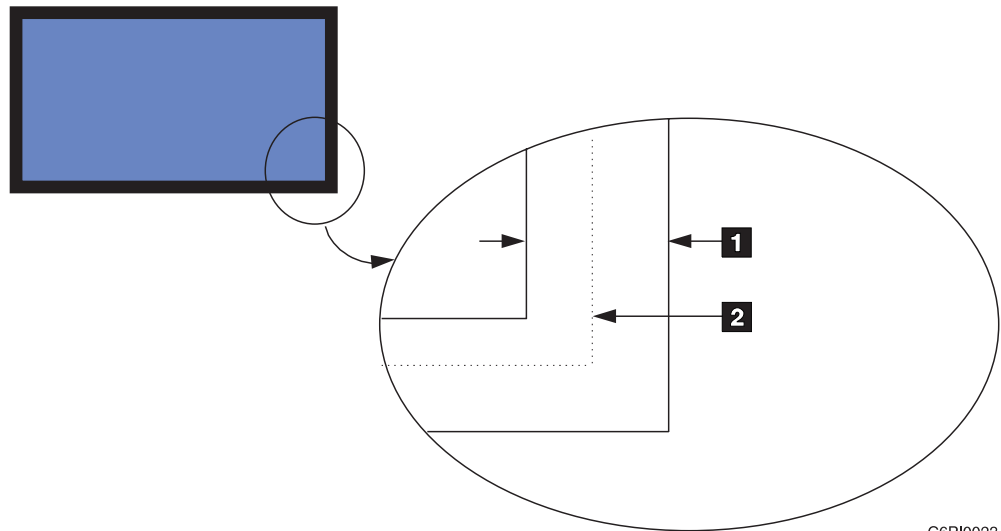

C6PI0023

Figure 21. Overspraying Solid Areas With Black Borders

- **1** 10 — pel wide border
- **2** Color fill overlaps border

**Note:** For overspraying to work, the black elements must appear AFTER the highlight color elements in the IPDS data stream.

- Black ink

For very tight registration between black and color pels, such as a logo with a black outline, black ink can be ordered for the HCPP. The black pels in the logo can be printed on the HCPP, allowing for improved registration between the black and color pels of the logo.

## Print Head Skew

Skew defines how tightly printed pels stay together within the pel map. Skew is the registration of individual printed pels versus other printed pels in the same pel map.

The affects of skew are most noticeable when stitching (abutting) printheads together. Stitching of printheads refers to printing large images or text by abutting the coverage areas of two or more HCPP printheads (See Figure 8 on page 30). Application testing should be done to verify that the appearance of these stitched images meets the requirements of the end user. Procedures to improve stitching and other registration requirements are described below.

## Procedures to Improve Registration

In order to achieve the best print registration, the following procedures are available:

- Host Printer print adjust
- HCPP Calibrate
- HCPP Print Adjust

### Host Printer Print Adjust

This procedure is performed at the host printer. It is used to improve the registration between the host printer's black print and the print on a pre-printed form. Refer to the host printer's Operator's Guide for instructions on how and when to perform this procedure.

### HCPP Calibration

This procedure is performed at the HCPP. It uses the internal print samples function of the host printer. All host printer host attachments must be disabled to perform this procedure. This procedure is used to improve the registration between the host printer's black print, and the HCPP's color print. An HCPP Calibrate procedure takes about 10 minutes to perform and can use up to 300 feet of paper. In general, you should perform an HCPP Calibrate procedure:

1. After you change paper rolls when using roll feed.
2. After you change paper lots if you are using boxed paper.

**Note:** Roll feed paper is recommended with the HCPP.

3. After you change printheads in the HCPP.
4. After any host printer print quality adjustment.

### HCPP Print Adjust

This procedure is performed at the HCPP using a real print job. After the procedure, the print job should be restarted and any output produced during the Print Adjust procedure should be discarded. This procedure is used to improve the registration between the HCPP's color print and the print on a pre-printed form. It can also be used to improve the registration between HCPP printheads for those situations

where this registration is critical (stitching printheads). Finally, it can be used to improve the registration between the HCPP color print and the host printer black print. A HCPP Print Adjust procedure takes about 10 minutes to perform and can use up to 300 feet of paper. Perform a HCPP Print Adjust Procedure:

1. After a setup has been loaded which changes the positions of the printheads.
2. After a Calibrate procedure has been performed.

## **Environmental Considerations**

The guidelines in this section represent actions to maximize print quality. Depending on your building environment, you may not have to perform these procedures as often as recommended by the guidelines. The following requirements increase the need to perform Calibrate and Print Adjust procedures:

1. Jobs which require stitching printheads together. Stitching printheads is the use of multiple printheads whose coverage areas are abutted in order to print images, patterns, or text which is wider than a single printhead's coverage area. For example, a corporate logo which requires more than one printhead to print.
2. Jobs which require tight registration between host printer black print and HCPP color print. For example, filling a black border (printed by the host printer) with color.
3. Jobs which require tight registration between preprinted forms and the color HCPP print. For example, filling a pre-printed border with color.
4. Uncontrolled environmental conditions in your paper storage facility. Paper may shrink slightly when it is fused by the fuser roll in the host printer. The amount of shrinkage depends to some extent on the moisture content of the paper. Rolls of paper which are all stored at the same environmental conditions should shrink approximately the same amount, requiring fewer Calibrations and Print Adjusts to adjust for changing characteristics of the paper.

## **Minimize Starts and Stops of Paper Motion**

The first few pages printed by the InfoPrint Hi-Lite Color after the start of paper motion exhibit the widest range of registration variation. For best results, try to minimize starts and stops of paper motion while using the HCPP. Print jobs which start and stop frequently will not be able to achieve the same level of print registration as those which do not.

---

## Chapter 6. Ordering Considerations

The Planning Coordinator should work with the IBM Printing Systems Company sales representative to ensure that the correct configuration and options for the HCPP are ordered. The following should be considered:

- Ink Colors:

Choosing the ink colors and ordering them in time for system delivery are critical to success with the HCPP. "Chapter 7. Ordering Supplies" on page 55 describes the ordering process in more detail.

- Additional Reservoirs:

If your installation uses more than four ink colors, an additional ink reservoir unit can be purchased. This unit increases the maximum number of ink colors in the system enclosure from four to eight.

**Note:** AFP print jobs for the HCPP can use three colors concurrently.

- Additional Printheads:

Once a printhead has been used for a specific ink color, the printhead remains dedicated to that ink color for the life of the printhead. If your installation requires more than eight printheads, additional printheads can be ordered.

**Notes:**

1. Only eight printheads can be accommodated in the system enclosure at one time.
2. Changing printheads in the system enclosure requires a key operator and takes approximately two hours of machine downtime.

- 90° flipper Units:

No 90° flipper units are provided with the HCPP. If units are required, contact your post-processor vendor to order the unit.

- Check cable lengths to existing postprocessing equipment. Verify that your existing cables will be long enough after the HCPP has been added to the forms path.

---

## Host Printer Requirements

The following are the host printer minimum requirements:

- AFCCU 8.523 microcode or later
- Feature code 4720 "Advanced Function Post-Processor Interface Feature"
- In dual simplex and duplex operations, full speed (229 ipm) duplex upgrade is required. Speed switching is not allowed for host printers attached to the HCPP.
- Some 3900 or InfoPrint 4000 printers experience "tension arm down" problems frequently. For those 3900 or InfoPrint 4000 printers with this problem, addition of the HCPP will increase its frequency. A tension arm spring can be ordered and mounted on the host printer that will increase tension on the arm. The IBM part number for the spring is 04H0563.
- IBM recommends that AFCCU's be upgraded to 64 MB of memory for host printers attached to the HCPP.

# Umbilical Connections

At installation time, the CE must install the umbilical connections between the ink reservoirs and the printheads. Work with the applications programmer to decide how many printheads of each color are required and then fill out the Printhead Requirements Worksheet. The CE needs this worksheet to complete the installation of the HCPP.

## Printhead Requirements Worksheet

Prepared by:

Name: \_\_\_\_\_ Title: \_\_\_\_\_

Ink Color Number (ACSnnnn)	Number of printheads using this color in the HCPP (Total printheads ≤ 8)	Number of printheads on the shelf with this color
_____	_____	_____
_____	_____	_____
_____	_____	_____
_____	_____	_____
_____	_____	_____
_____	_____	_____
_____	_____	_____
_____	_____	_____

## Printhead Requirements Worksheet

Prepared by:

Name: \_\_\_\_\_ Title: \_\_\_\_\_

Ink Color Number (ACSnnnn)	Number of printheads using this color in the HCPP (Total printheads ≤ 8)	Number of printheads on the shelf with this color
_____	_____	_____
_____	_____	_____
_____	_____	_____
_____	_____	_____
_____	_____	_____
_____	_____	_____
_____	_____	_____
_____	_____	_____

## Printhead Requirements Worksheet

Prepared by:

Name: \_\_\_\_\_ Title: \_\_\_\_\_

Ink Color Number (ACSnnnn)	Number of printheads using this color in the HCPP (Total printheads ≤ 8)	Number of printheads on the shelf with this color
_____	_____	_____
_____	_____	_____
_____	_____	_____

_____	_____	_____
_____	_____	_____
_____	_____	_____
_____	_____	_____

Printhead Requirements Worksheet

Prepared by:

Name: \_\_\_\_\_ Title: \_\_\_\_\_

Ink Color Number (ACSnnnn)	Number of printheads using this color in the HCPP (Total printheads ≤ 8)	Number of printheads on the shelf with this color
----------------------------------	---	---

_____	_____	_____
_____	_____	_____
_____	_____	_____
_____	_____	_____
_____	_____	_____
_____	_____	_____
_____	_____	_____
_____	_____	_____





---

## Chapter 7. Ordering Supplies

Supplies for the HCPP consist of the standard or custom ink used in the printing process.

---

### Standard and Custom Ink Colors

The following describes the ordering process for standard and custom ink colors.

#### Ordering Standard Ink Colors

IBM provides a palette of standard ink colors to choose from. These pre-mixed colors cover a broad spectrum of customer needs. Work with your IBM marketing representative to choose the standard colors that meet the needs of your company.

**Note:** The initial order of standard ink colors should be placed 4 to 6 weeks prior to delivery of the HCPP to ensure a timely installation. Call 1-800-346-3939 to order your standard ink colors.

#### Ordering Custom Ink

Call your IBM marketing representative when the standard palette of ink colors does not satisfy your color requirements. The process for designing and manufacturing the initial order of custom ink colors takes 6 weeks.

**Note:** It is important to start this process at least 6 weeks prior to delivery of the HCPP, since ink must be on-site for installation of the HCPP to proceed. The IBM contact is Gary Thrasher (607) 755-5949, Fax (607) 755-1035, or internet address [gthrasher@vnet.ibm.com](mailto:gthrasher@vnet.ibm.com).

---

### Storing and Handling of Ink

The HCPP uses solid ink jet technology, which means it is a solid at room temperatures. Ink should be stored in a location where the temperature range is -20° to 40°C (-4° to 104°F).

Ink is shipped in boxes containing 6 Kg of ink. Within those boxes, the ink is packaged in individual plastic packages, each containing a single block of approximately 100 grams of ink.

**Note:** To prevent contamination, each block of ink must remain in its individual plastic package until used. The *InfoPrint Hi-Lite Color Operator's Guide* describes the process for handling the ink during the ink loading operation.

---

### Ink Consumption Rates

In order to place your initial order of ink, you must compute how much of each ink color you will consume on a monthly basis.

The consumption rate for ink is directly proportional to the amount of color coverage on the page. For each ink color, the consumption rate for ink can be expressed as follows:

$$\text{Kgs/Month} = \{(A \cdot a \cdot a') + (B \cdot b \cdot b') + (C \cdot c \cdot c') \dots\} / D$$

Where:

- $(A \cdot a \cdot a')$  = Number of square inches of that color printed on application A per month. The components are:
  - $A$  = Color Coverage in Application A  
This value represents the average amount of the color's coverage on the page for application A.  $A$  is expressed as a value between 0 and 1. This value can be easily computed by dividing the number of square inches of color coverage on a page of that color by the total number of square inches on the page.
  - $a$  = Total Number of square inches on a page of application A  
"a" is expressed as an integer.
  - $a'$  = Number of pages per month of application A  
This value is the average number of pages per month printed by application a. "a'" is expressed as an integer.
- $D = 172,000$   
D is a constant equal to 172,000.

The above calculation computes the number of kilograms of a certain color consumed every month for printing and purging operations. This calculation should be performed for each color used. For an installation averaging 1.2 million impressions per month, with 0.5% coverage on the page for each color, this calculation comes to about 3.25 Kg/month per color.

---

## Chapter 8. Selecting and Testing Forms

This Chapter reviews the basic requirements for print materials intended for use on the HCPP. It also contains an informal question-and-answer section to help you identify and avoid potential forms-related problems.

In general, forms that work well in the host printer will work well in the HCPP. Therefore, to get maximum reliability and print quality from the HCPP, IBM recommends that you read the *Forms Design Reference for Continuous Forms Advanced Function Printers* document.

In addition the *Forms Design Reference for Continuous Forms Advanced Function Printers*, the following paper parameters must be within the following ranges for forms used in the HCPP.

- Paper Porosity (Gurley): 10 sec/100 ml to 30 sec/100 ml
- Paper Smoothness (Sheffield): 100 to 200 (For best print quality: 120 to 150)
- Paper Weight: 60 g to 105 g (16 lb to 28 lb)
- The HCPP supports a running forms length in the range: 7.62 cm to 43.21 cm (3 in to 17 in)

Your forms manufacturer/supplier is able to provide you with the paper weight, porosity and smoothness measurements. Work with your forms supplier, and your IBM marketing representative to choose the best forms and special-purpose materials for your applications.

---

### Continuous Forms

Both the host printer and HCPP generally use single-ply, continuous forms with both edges punched for tractor feeding and with horizontal perforations between the sheets. Micro-perforated forms can be used for cleaner cuts between sheets. Either boxed fan-fold forms, or with appropriate pre-processing and post-processing devices attached, roll-feed forms may be used.

**Note:** IBM recommends roll feed forms.

Not all combinations of paper width and weight are supported on all host printer configurations. See the appropriate host printer publications to determine supported combinations for your specific configuration.

---

### Special-Purpose Materials

Discuss your special-purpose applications with your forms suppliers and ensure that they understand that the forms are being run on an HCPP. Before you use new forms for production runs, test the jobs that print them to ensure everything works well.

Work closely with your IBM marketing representative while you are selecting what kinds of forms to use. Your marketing representative can give you technical help, share information from other successful HCPP users, and help you design your own special materials.

## Preprinted Forms

If you are planning to use preprinted forms (for example, your company letterhead), ensure that the ink is designed for non-impact printing. Certain inks are likely to rub off or smear after they have been heated by the fuser in the host printer. See *Forms Design Reference for Continuous Forms Advanced Function Printers*, for additional recommendations when selecting ink for preprinted forms.

## Adhesive Labels

**Note:** Adhesive Labels are not recommended for use on the InfoPrint Hi-Lite Color.

---

## Storing Print Materials

Store forms and special-purpose materials in an area where temperature and humidity are similar to the environment in which they are used. If forms are allowed to absorb too much moisture, wrinkles and blank spots may result.

Avoid areas with extreme heat or humidity. Extended exposure to these extremes can permanently damage the materials. Also, storing forms in an area where relative humidity is above 65% may result in reduced print quality.

---

## Questions and Answers about Testing Forms and Applications

These questions and answers can help you decide what forms and applications to test, and how to test them.

### What is an Ideal HCPP Application?

An ideal application for the HCPP would print text and images on plain white paper, 75 g (20 lb) bond. This paper would be manufactured specifically for use in non-impact printers such as the host printer, and would be free of binder holes, cut-outs, and other cuts. The porosity would be 10 — 15 sec/100 ml and the smoothness 120 - 150 Sheffield units. The page layout would keep text and images away from perforations. After leaving the HCPP, output from an ideal application would be allowed to cool, and would receive minimal handling, rubbing, and creasing.

When it is processing an ideal application, the HCPP can deliver maximum print quality and reliability. With applications that deviate from the ideal, print quality may decrease, and the need for operator interventions may increase. This does *not* mean that the HCPP cannot be used for the application; it *does* mean that you need to test the application.

### What Would Make My Application Different from the Ideal?

You should probably test an application if the page layout includes:

- Bar codes
- OCR print
- Printing near perforations
- Large amounts of text in very small fonts
- Images

**Note:** Bar code is not recommended for printing in highlight color.

You should also test if the output is printed on:

- Preprinted forms
- Light or heavy forms
- Rigid forms
- Very smooth forms
- Non-porous forms
- Colored paper
- Recycled paper
- Forms with binder holes, cut-outs, or other cuts
- Forms with running perforations or multiple perforations

Sometimes an application is a candidate for testing because of what happens to the output after it leaves the printer and the HCPP. Here are some examples to stimulate your thinking:

- Heat and pressure

The host printer uses heat and pressure to put print on the form; the HCPP uses heat to put print on the form; therefore, heat and/or pressure applied to printed output can change the output. For example, if you take forms still warm from the HCPP and put them into a tall stack, the weight of the stack can cause pages to stick together. The same effect can result from using a shearing press to cut stacks of warm forms.

- Moisture

Water and other solvents can cause the print to smear on some forms. For example, perspiration on an operator's hand might leave a blurry thumbprint.

- Handling

Frequent handling or rubbing can erase print from a form. For example, print on a price tag might rub off as shoppers repeatedly grasp the tag to look for size and price information.

## What Will Testing Tell Me?

When you test, you can expect one of the following results:

- The application completes successfully and you are satisfied with the output
- The application cannot run at all
- The application completes, but with some reduction in print quality or printer reliability

If your application is in the last category you need to review the output and your requirements, and then decide whether you are satisfied with the quality and reliability achieved. Sometimes, you may be able to make changes that improve the test results. Here are some possibilities:

- Adjust the HCPP and the host printer

The host printer's print quality controls are accessible to the operator. The appropriate operator's guide describes how to use the Contrast and Forms Select controls on the printer control panel to improve print quality.

The *InfoPrint Hi-Lite Color Operator's Guide* describes how to adjust for paper type to optimize color ink adherence to the page.

- Adjust the process

Changing any one element in the overall printing process can affect other elements. Review your task from start to finish to determine where adjustments can be made. For example, consider the following:

Can I change the forms?

Can I change the way the forms are stored?

Can I change the application?

Can I change the way the forms are handled after printing?

- Example:

If you are having trouble with a particular preprinted form, consider whether you can achieve the result you need with an electronic overlay, and eliminate the preprinted form completely.

Consult with your IBM supplies representative as a source of information about forms and applications that are being used successfully with HCPP.

## What Kind of Testing Should I Do?

For detailed information on deciding what forms and applications to test and how to test them, see *Forms Design Reference for Continuous Forms Advanced Function Printers G544-3921*.



# Setup Design Worksheet

Setup Text Name: \_\_\_\_\_  Hide

Setup Verification ID: \_\_\_\_\_  
(two-byte hexadecimal ID)

Color Side: Color on Front  Color on Back

## Virtual Printheads

Ink Color	AFP Highlight Color # (1, 2, or 3)	Location (in pels)	Width (in pels)

Prerequisite Setups:  
(Setup Verification ID's)

#1  #2  #3

C6PI0014



# Setup Design Worksheet

Setup Text Name: \_\_\_\_\_  Hide

Setup Verification ID: \_\_\_\_\_  
(two-byte hexadecimal ID)

Color Side: Color on Front  Color on Back

## Virtual Printheads

Ink Color	AFP Highlight Color # (1, 2, or 3)	Location (in pels)	Width (in pels)

Prerequisite Setups:  
(Setup Verification ID's)

#1  #2  #3

C6PI0014

# Setup Design Worksheet

Setup Text Name: \_\_\_\_\_  Hide

Setup Verification ID: \_\_\_\_\_  
(two-byte hexadecimal ID)

Color Side: Color on Front  Color on Back

## Virtual Printheads

Ink Color	AFP Highlight Color # (1, 2, or 3)	Location (in pels)	Width (in pels)

Prerequisite Setups:  
(Setup Verification ID's)

#1  #2  #3

C6PI0014

## Setup Design Worksheet

Setup Text Name: \_\_\_\_\_  Hide

Setup Verification ID: \_\_\_\_\_  
(two-byte hexadecimal ID)

Color Side: Color on Front  Color on Back

### Virtual Printheads

Ink Color	AFP Highlight Color # (1, 2, or 3)	Location (in pels)	Width (in pels)

Prerequisite Setups:  
(Setup Verification ID's)

#1

#2

#3

C6PI0014

## Setup Design Worksheet

Setup Text Name: \_\_\_\_\_  Hide

Setup Verification ID: \_\_\_\_\_  
(two-byte hexadecimal ID)

Color Side: Color on Front  Color on Back

### Virtual Printheads

Ink Color	AFP Highlight Color # (1, 2, or 3)	Location (in pels)	Width (in pels)

Prerequisite Setups:  
(Setup Verification ID's)

#1  #2  #3

C6PI0014

# Setup Design Worksheet

Setup Text Name: \_\_\_\_\_  Hide

Setup Verification ID: \_\_\_\_\_  
(two-byte hexadecimal ID)

Color Side: Color on Front  Color on Back

## Virtual Printheads

Ink Color	AFP Highlight Color # (1, 2, or 3)	Location (in pels)	Width (in pels)

Prerequisite Setups:  
(Setup Verification ID's)

#1  #2  #3

C6PI0014

# Setup Design Worksheet

Setup Text Name: \_\_\_\_\_  Hide

Setup Verification ID: \_\_\_\_\_  
(two-byte hexadecimal ID)

Color Side: Color on Front  Color on Back

## Virtual Printheads

Ink Color	AFP Highlight	Location (in pels)	Width (in pels)
	Color # (1, 2, or 3)		

Prerequisite Setups:  
(Setup Verification ID's)

#1  #2  #3

C6PI0014

---

## Appendix B. Acronyms and Abbreviations

This list explains the acronyms and abbreviations used in this manual, and in the other manuals that are part of the printer documentation library.

**ABIC** Adaptive Bi-Level Image Compression.

**AEA** Alternate Exception Action.

**AFCCU**

Advanced Function Common Control Unit.

**AFIG** Advanced Function Image and Graphics.

**AFP** Advanced Function Presentation.

**AFPF** Advanced Function Print Finishing.

**APA** All-Points Addressable.

**ARQ** Active Record Queue.

**ASHRAE**

American Society of Heating, Refrigeration, and Air Conditioning Engineers.

**BCOCA**

Bar Code Object Content Architecture

**CCW** Channel Command Word.

**CE** Customer Engineer (IBM).

**CSW** Channel Status Word.

**DASD** Direct Access Storage Device.

**DCF** Document Composition Facility.

**DPE** Decompression Performance Enhancement.

**EBCDIC**

Extended Binary-Coded Decimal Interchange Code.

**EC** Engineering Change.

**ESCON**

Enterprise System Connection

**ESMM** End Select Medium Modification.

**FLSF** Font Library Service Facility.

**FORMDEF**

Form Definition.

**Form definition**

Form definitions are control resources that obtain information about how a page of details presented on the print medium (paper). Form definition specify paper source, number of copies, which overlay to use, and printed on one or both sides, etc..

**GDDM**

Graphical Data Display Manager.

**GOCA** Graphics Object Content Architecture

**IBM MMR**

Similar to MMR 2-dimensional image compression algorithm.

**IHF** Image Handling Facility.

**IML** Initial Microcode Load.

**IOCA** Image Object Content Architecture

**IPDS** Intelligent Printer Data Stream.

**ISO** International Organization for Standardization.

**JES2** Job Entry System 2.

**JES3** Job Entry System 3.

**KB** Kilobyte (1KB=1 024 bytes).

**MB** Megabyte (1MB=1 048 576 bytes).

**MICR** Magnetic Ink Character Recognition.

**MIH** Missing-Interrupt Handler.

**MMC** Medium Modification Control

**MMR** Modified-Modified READ; 2-dimensional image compression algorithm. Also referred to as TSS Group 4.

**MO:DCA**  
Mixed Object Document Content Architecture

**MOIOCA**  
Mixed Object Image Object Content Architecture

**MR** Modified READ; (READ=Relative Element Address Designate)  
2-dimensional image compression algorithm. Also referred to as TSS Group 3.

**MVS** Multiple Virtual Storage.

**MVS/SP**  
Multiple Virtual Storage/System Product.

**NPRO** Nonprocess Runout.

**OCR** Optical Character Recognition.

**OGL** Overlay Generation Language.

**OS/VS**  
Operating System/Virtual Storage.

**Overlay**  
Overlays are collections of coded information describing where to put boxes, lines, shading, text, logos, and graphics on forms.

**PAGEDEF**  
Page Definition.

**PC** Photoconductor.

**PEM** Print-Error Marker.

**PMF** Print Management Facility.

**PPFA** Page Printer Formatting Aid.

**PSAF** Print Services Access Facility.

**PSF** Print Services Facility.

**PUM** Printer Utility Module



**RAM** Random Access Memory.  
**RPQ** Request for Price Quotation.  
**SCSW** Subchannel Status Word.  
**SDLC** Synchronous Data Link Control.  
**SMM** Select Medium Modification.  
**SNA** System Network Architecture  
**TCS** Two-Channel Switch.  
**TSS** Telecommunication Standardization Sector  
**VSE** Virtual Storage Extended.  
**VSE/AF**  
Virtual Storage Extended/Advanced Functions.  
**VSE/SP**  
Virtual Storage Extended/System Product.



---

# Glossary

The following terms are defined as they are used in this document. If you do not find the term you need, see the index or the *IBM Dictionary of Computing*, SC20-1699.

The following cross-references are used within this glossary:

- **Contrast with.** This refers to a term that has an opposed or substantively different meaning.
- **Synonym for.** This indicates that the term has the same meaning as another term, which is defined.
- **Synonymous with.** This identifies terms that are synonyms for the term that is defined.
- **See.** This refers to multiple-word terms that have the same last word.
- **See also.** This refers to related terms that have a similar, but not synonymous, meaning.

## A

**adaptive bi-level image compression (ABIC).** A 4-bit image capable of displaying up to 16 shades of gray.

**adhesive label.** Special-application material; typically consists of paper labels coated on one side with an adhesive mixture temporarily affixed to backing material. See also *carrier*.

**Advanced Function Image and Graphics.** A integral facility within the printer to directly process IOCA image and GOCA graphics data streams.

**all-points addressability.** The capability to address, reference, and position text, overlays, and images at any defined point on the printable area of a page.

**application.** The use to which an information processing system is put; for example, a payroll application, an airline reservation application, a network application.

**application program.** A program written for or by a user that applies to the user's work, such as a program that does inventory control or payroll.

**application programmer.** A person who develops application programs. Contrast with *system programmer*.

**auto load.** In the printer, the automatic forms threading facility.

## B

**bar code.** A code representing characters by sets of parallel bars of varying thickness and separation that are read optically by transverse scanning.

**basis weight.** The weight in pounds of a ream (500 sheets) of paper cut to a given standard size for that grade; for example, 25 x 38 inches for book papers, 17 x 22 inches for bond papers, and other sizes for other grades. The basis weight of continuous forms for computer output is based on the size for bond papers.

**binder holes.** A series of holes or slots punched at set intervals that allows the form to be inserted in a loose-leaf or ring binder.

**bond (paper).** Paper formulated with at least 80% wood pulp. Bond-paper forms work best in the printer.

**black-and-white.** Originals in a single color, as distinguished from multicolor.

**bleed.** A print image which extends beyond the trim edge of the form.

## C

**calendar.** A process to make paper smooth or glossy by passing it through a series of metal rollers during the last steps of a paper-making machine.

**calendar cut.** Slits, glazed lines, or discolored lines across the paper caused when wrinkles pass through the calendar rollers.

**caliper.** The thickness of forms. This is usually expressed in thousandths of an inch.

**carrier.** The backing material for labels. Labels consist of the printable material, the adhesive, and the carrier.

**chad.** (1) The material separated from a data medium when punching a hold. (2) The residue separated from the carrier holes in continuous forms.

**change.** As used in printer action messages, instructs the printer operator to remove and discard a used component and then install a new one. For example, the CHANGE TONER COLLECTOR message indicates that the operator should take out the toner-collector bottle, throw it away, and put in a new one.

**channel command.** An instruction directing a data channel, control unit, or device to perform an operation or set of operations.

**character.** A letter, number, punctuation mark, or special graphic used for the production of text.

**character set.** (1) A finite set of different characters that is complete for a given purpose; for example, the character set in ISO Standard 646, "7-bit Coded Character Set of Information Processing Interchange."  
(2) A group of characters used for a specific reason; for example, the set of characters a printer can print.

**check.** As used in printer action messages, instructs the printer operator to inspect a component. For example, the CHECK TONER COLLECTOR message indicates that the operator should look at the toner-collector bottle and ensure that it is physically present, in the proper place, and correctly installed.

**clear.** As used in printer action messages, instructs the printer operator to remove crumpled forms, paper scraps, and other debris from the printer. For example, the CLEAR UPPER TRACTOR message indicates that forms are wedged in the transfer station area, and the operator must remove them before the printer can operate.

**CMYK.** Cyan, Magenta, Yellow, Black - The four basic colors used in offset printing, as opposed to the three basic colors of light: red, green, and blue. Note: red (magenta), yellow, and blue (cyan) are thought of as the subtractive primaries. Black is added to give better density and to produce a true black.

**coated paper.** Paper that has had a surface coating applied to produce smoothness.

**configuration.** (1) The arrangement of a computer system or network as defined by the nature, the number, and the chief characteristics of its functional units. More specifically, the term configuration may refer to a hardware configuration or a software configuration.  
(2) The devices and programs that make up a system, subsystem, or network.

**configure.** The procedure used to customize the printer to a specific operating and communication environment.

**connector.** A means of establishing electrical flow.

**constant data.** Data that does not change; for example, the company letterhead and standard text in form letters, or the headings and boxes on a preprinted form. Contrast with *variable data*.

**continuous forms.** A series of connected forms that feed continuously through a printing device. The connection between the forms is perforated to allow the user to tear them apart.

**contrast.** the tonal gradation between the highlights, middle tones and shadows in an original or reproduction.

**controlled-access area.** An area where access is limited to authorized personnel.

**controlling computer.** The processing unit to which the printer is attached through a channel interface.

**controlling computer system.** The data-processing system to which a network is connected and with which the system can communicate.

**corner cut.** In a form, a cut or opening of any size containing one or more right angles.

**corona.** A small diameter wire (or wires, depending on the function) to which a high voltage is applied, causing ionization of the air. The ionization creates an electrical charge to perform various functions during the printing process.

**cure.** The process of drying ink sufficiently for minimum transfer of the ink to any parts of the printer it contacts.

**cut.** The severed part of a perforation. Cuts are separated by ties. See also *perforation*.

**cutout.** A part of the form that has been eliminated or perforated for subsequent removal; for example, corner cuts and binder holes.

## D

**data streaming.** A non-interlocked method of data transfer used by the printer channel to decrease data transfer time during write operations.

**developed image.** The image that has been exposed onto the photoconductor and covered with toner by the developer.

**developer mix.** A combination of carrier beads and toner in which the beads electrically charge the toner.

**diagnostic.** Pertaining to the detection and isolation of errors in programs and faults in equipment.

**diagnostic mode.** The operational mode in which the printer can check itself in case of a malfunction. When the printer is in diagnostic mode, it is not accepting information from the attached controlling computer system. In the printer, only service representatives can use diagnostic mode. Contrast with *print mode*.

**direct attach.** The environment in which an application program directly allocates the printer.

**dishing.** The curve a stack of forms takes when folded or refolded at the fold perforation.

**diskette.** A thin, flexible, magnetic disk enclosed in a protective jacket.

**Document Composition Facility (DCF).** An IBM licensed program that provides text formatting for the printer.

**dots per inch (dpi).** a measure of the resolution of a screen image or printed page. Spots per inch (spi) or picture element (pel) are the same as dpi.

**down fold.** Fanfold forms are alternately folded. When fanfold forms are unfolded and held horizontally, a fold is a down fold if it points down from the horizontal surface.

**drag.** The resistance to forms feeding freely into the printer; for example, the form rubbing against the carton.

**duplex printing.** A mode of printing on both sides of a form. Contrast with *simplex printing*.

## E

**electronic overlay.** A collection of constant data electronically composed in the controlling computer. Can be merged with variable data on a page during printing. An electronic overlay defines its own environment. It can be in coded form or raster pattern form. See also *preprinted form*.

**electrophotographic process.** The creation of an image on forms by uniformly charging the photoconductor, creating an electrostatic image on the photoconductor, attracting negatively charged toner to the discharged areas of the photoconductor, and transferring and fusing the toner to forms.

**emboss.** To press and raise the surface of paper into a design. Embossed paper appears thicker than non-embossed paper, can increase printer wear, and can degrade print quality.

**end-of-forms sensor.** A sensor that detects when the last sheet of a form enters the printer.

**error log.** (1) A data set or file in a product or system where error information is stored for later access. (2) A record of machine checks, device errors, and volume statistical data.

**ESCON channel.** A channel having an Enterprise Systems Connection channel-to-control unit I/O interface that uses serial-by-bit optical cable as a transmission medium.

## F

**fanfold.** Continuous forms that are alternately folded at regular intervals, usually on a perforation.

**fold memory.** The ability of a form to refold at the fold perforation after exposure to heat during the fusing process.

**fold perforation.** The perforation on which a form is folded during manufacture and refolded after printing. See also *page perforation*.

**font.** A complete assortment of letters, numbers, punctuation marks, etc. of a given size and design.

**Font Library Service Facility (FLSF).** A licensed program that provides a way to make changes to a font while retaining its correct format, as defined by the architecture and as required by Print Services Facility.

**format.** (1) The arrangement or layout of data on a data medium. (2) The size, style, type of page, margins, printing requirements, and so on, of a printed page.

**forms.** The material on which output data is printed, such as paper or adhesive labels. The area between perforations on continuous printer forms. See *electronic overlay* and *preprinted form*.

**form definition.** A print control object that contains an environment definition and one or more Medium Maps. Synonymous with *Form map*.

**form map.** A print control object that contains an environment definition and one or more Medium Maps. Synonymous with *Form Definition*. See also *Medium Map*.

**forms path.** The entire route that forms travel during processing. The forms path usually begins where the forms are loaded and ends at the stacker. Synonym for *paper path*.

**form definition (FORMDEF).** A statement that specifies the attributes of a physical page, such as the number of copies and one-sided or two-sided printing.

**fuse.** To use heat and pressure to blend toner onto forms to make a permanent bond.

## G

**graphic.** A symbol produced by a process such as handwriting, drawing, or printing. See also *vector graphics*.

**Graphical Data Display Manager (GDDM).** An IBM licensed program that allows pictures to be defined and displayed through function routines.

## I

**IBM branch office.** The local IBM sales office.

**IBM installation planning representative.** An IBM representative who assists customers in planning and meeting the requirements for installing hardware.

**IBM marketing representative.** An IBM representative who takes your order.

**IBM service representative.** An IBM representative who services IBM products in the field.

**IBM World Trade Corporation.** A subsidiary of IBM that manufactures and markets IBM products outside of the United States of America.

**impact printer.** A printer in which printing is the result of mechanical impacts. Contrast with *nonimpact printer*.

**installation.** (1) In system development, preparing and placing a functional unit in position for use. (2) A particular computing system, including the work it does and the people who manage it, operate it, apply it to problems, service it, and use the results it produces.

**installation verification procedure.** A procedure distributed with IBM licensed programs that tests the newly installed IBM programs to verify that the basic facilities of the programs are functioning correctly.

**Intelligent Printer Data Stream (IPDS).** Information the system sends to printers that contains decision-making capability. Generally, this information contains basic formatting, error recovery, and character data.

**ISO sizes.** Pertaining to a set of paper sizes selected from those standardized by the International Organization for Standardization (ISO) for use in data processing.

## J

**jam.** In a printer, a condition where forms have become blocked or wedged in the forms path so the printer cannot operate.

**JES2.** An MVS subsystem that receives jobs into the system, converts them to internal format, selects them for running, processes their output, and purges them from the system. In an installation with more than one processor, each JES2 processor independently controls its job input, scheduling, and output processing. See also *JES3*.

**JES3.** An MVS subsystem that receives jobs into the system, converts them to internal format, selects them for running, processes their output, and purges them from the system. In complexes that have several loosely coupled processing units, the JES3 program manages processors so that the global processor exercises centralized control over the local processors and distributes jobs to them via a common job queue. See also *JES2*.

## L

**landscape orientation.** Text and images that are printed parallel to the longer side of the forms. Contrast with *portrait orientation*.

**laser (light amplification by stimulated emission of radiation).** A device that emits a beam of coherent light.

**latent image.** In a printer, the invisible image that exists in the sensitized material after exposure but before development.

**layout plan.** A list of requirements, such as electrical and space, that must be considered before installing the IBM printer.

**library.** A collection of related files. For example, one line of an invoice may form an item, a complete invoice may form a file, and the collection of inventory control files may form a library. The libraries used by an organization are known as the data bank.

**licensed program.** A separately priced program that bears an IBM copyright and is offered to customers under the terms and conditions of the Agreement for IBM Licensed Programs.

**line printer.** A printer that prints a line of characters as a unit. Contrast with *page printer*.

**logical page.** A presentation space in which the page data is presented.

**logo.** An identifying emblem, statement, or motto of a company.

## M

**medium map.** A print control object in a Form Map that defines resource mappings and controls modifications to a form, page placement on a form, and form copy generation. See also *Form Map*.

**microcode.** In the printer, refers to the microprogramming stored on the control unit hard disk. Microcode is used by the control unit to manage the printer and its functions.

**microperforation.** Extremely small perforations. After forms are separated, those with microperforations typically have smoother edges than those with regular perforations.

**Multiple Virtual Storage/System Product (MVS/SP).** Consisting of MVS/System Product Version 1 and the MVS/370 Data Facility Product operating on a System/370 processor.

## N

**nonimpact printer.** A printer in which printing is not the result of mechanical impacts. Contrast with *impact printer*.

**nonprocess runoff (NPRO).** An operation that moves forms through the forms path without printing.

## O

**offset paper.** A grade of paper to which sizing is added to resist moisture and surface during printing by ink presses.

**operating environment.** The physical environment; for example, temperature, humidity, layout, or power requirements.

**operating requirements.** A list of requirements, such as environmental, electrical, and space, that must be satisfied before the IBM printer can be installed.

**Operating System/Virtual Storage (OS/VS).**

A compatible extension of the IBM System/360 Operating System that supports hardware and the extended control facilities of System/370.

**optical character recognition (OCR).** Character recognition that uses optical means to identify graphic characters.

**orientation.** The number of degrees an object is rotated relative to a reference; for example, the orientation of an overlay relative to the page point of origin. See also *text orientation, landscape, and portrait.*

**overlay.** (1) A resource object that can contain text, image, graphics, and bar code data. Overlays define their own environment, and are often used as electronic forms. (2) The final representation of such an object on a physical medium. Contrast with *page segment.*

**overlay.** See *electronic overlay.*

**Overlay Generation Language/370 (OGL/370).** The licensed program that is used to create electronic overlays.

## P

**page.** (1) A data stream object delimited by a Begin Page structured field and an End Page structured field. A page can contain presentation data such as text, image, graphics, and bar code data. (2) The final representation of a page object on a physical medium.

**page definition (PAGEDEF).** A statement that specifies attributes of a logical page, such as the width of its margins and the orientation of text. Page definitions control resources that contain information about the placement of line data on a page. Page definitions specify such things as line positioning and page length, fonts, and rotation.

**page map.** A print control object used to format line data into page data. A Page Map contains one or more Data Maps and may optionally specify conditional processing of the line data. Synonymous with *Page Definition.*

**page perforation.** The perforation that defines the page of a form. It may not be at a fold in the form. A form may have several pages between each fold. See also *fold perforation.*

**page printer.** A device that prints one page as a unit. Contrast with *line printer.*

**Page Printer Formatting Aid/370 (PPFA/370).** A licensed program that creates form definitions (FORMDEFS) and page definitions (PAGEDEFS).

**Page segments.** (1) In the IPDS architecture, a resource object that can contain text, image graphics, and bar code data. Page segments do not define their own environment, but are processed in the existing environment. (2) The final representation of such an object on a physical medium. Contrast with *overlay.*

**pallet.** A portable platform for handling, storing, or moving materials.

**paper break.** A separation, either at a perforation or from a tear, of the continuous-forms paper.

**paper path.** The entire route that forms travel while they are being processed. The paper path usually begins where the forms are loaded and ends at the stacker. Because not all forms are paper, the term *forms path* is preferred.

**parallel channel.** A channel having a System/360 or System/370 channel-to-control unit interface that uses parallel cable bus-and-tag as a transmission medium. Contrast with *ESCON channel.*

**parameter.** A variable that is given a constant value for a specified application and that may denote the application.

**PC drum.** A hollow cylinder that is covered with photoconductive material.

**pel (picture element).** (1) An element of a raster pattern; a point where a toned area on the photoconductor may appear. (2) On an all-points-addressable output medium, each pel is an addressable unit. On a row-column addressable output medium, the only pel addressable is the beginning of a character cell.

**perforation.** A linear series of unconnected cuts in the continuous-forms paper. The interval between cuts is referred to as a tie. The perforation defines either a fold or page boundary. See also *cut, fold perforation, microperforation, and page perforation.*

**photoconductor.** The material that is wrapped about the drum. The medium for transferring images to paper.

**physical planner.** The person in an organization who plans the environmental, electrical, and space requirements for your facility.

**pica.** A printer's unit of measurement. One pica equals approximately 1/6 of an inch.

**pixel.** See *pel*.

**planning coordinator.** The person in your organization who is responsible for coordinating all the planning and installation activities for the printer.

**plant.** A manufacturing location.

**point.** A unit of measurement. One point equals approximately 1/72 of an inch. There are 12 points to a pica.

**point of origin.** The location of the first print position on a logical page. The point of origin is usually stated in terms of X and Y coordinates. The point of origin used by a printer can be affected by factors such as printable area and forms orientation.

**portrait orientation.** Pertaining to a display or hard copy with greater height than width. Contrast with *landscape orientation*.

**preprinted form.** A sheet of forms containing a preprinted design of constant data with which variable data can be combined. See also *electronic overlay*.

**Print Management Facility (PMF).** An interactive menu-driven program that can be used to create and modify fonts and to define output formatting for data printed on the printer.

**print mode.** The operational mode in which information is received from the attached controlling computer system and printed output is produced. Contrast with *diagnostic mode*.

**print position.** The physical positions of the characters constituting a print line relative to the form.

**print quality.** The quality of printed output relative to existing standards and in comparison with jobs printed earlier.

**Print Services Access Facility (PSAF).** A menu-driven, print-parameter selection program for page printers controlled by PSF.

**print surface.** The side of a form that receives the printed image.

## R

**raster.** (1) In computer graphics, a predetermined pattern of lines that provides uniform coverage of a display space. (2) The coordinate grid that divides the display area of a display device. (3) In the printer Printer Subsystem, an on/off pattern of electrostatic images produced by the laser print head under control of the character generator.

**raster pattern.** A series of picture elements (pels) arranged in scan lines to form an image.

**registration.** In printing, refers to the relative print positions of images that are printed at different times. For example, when you process preprinted forms, the registration is good if the new image printed by the printer aligns correctly with the preprinted image. Print that extends beyond box edges and text that overlaps other text are examples of poor registration.

**resource.** (1) People, equipment, or material used to perform a task or a project. (2) Any facility of a computing system or operating system required by a job or task, including main storage, input/output devices, processing units, data sets, and controller processing programs; for example, page printers use resources such as form definitions, page definitions, and fonts.

**reverse heading.** A heading where each character is highlighted by reversing the color of the character with its background; for example, changing a black character on a white background to a white character on a black background.

**RGB.** Red, Green, Blue - additive primary colors.

## S

**scanner.** A device that examines OCR, graphics, MICR, or bar-code patterns and generates electrical signals corresponding to the pattern. It sends the signals to a computing device for processing.

**screen or screening.** In document printing, a sheet of material, usually film, carrying a regular pattern of small dots. When printing, ink adheres only to the dots, and many dots close together appear solid. This method prints large areas of ink on paper but uses much less ink than printing the same area with solid ink.

**security paper.** Specially formulated paper used for negotiable documents, such as checks, which improves the anti-fraud characteristics of the document.

**shift.** A scheduled work period. For example, a 24-hour day is often divided into three 8-hour shifts.

**simplex printing.** Pertaining to printing on only one side of a form. Contrast with *duplex printing*.

**sizing.** A process where paper is treated to give it resistance against penetration of liquids.

**special-purpose materials.** Printable items other than blank forms; for example, adhesive labels and preprinted forms.

**SRC.** See *system reference code*.

**stack lean.** A measurable slope from the vertical of a stack of forms. Excessive stack lean can cause failures when feeding and refolding forms.



**system reference code.** A code that contains information, such as a failing field-replaceable unit, for a customer engineer.

**system programmer.** A programmer who plans, generates, maintains, extends, and controls the use of an operating system, with the aim of improving overall productivity of an installation. Contrast with *application programmer*.

**System/370.** An upward-compatible extension of the IBM System/360. A large collection of computing system devices that can be combined to produce a wide range of computing systems that share many characteristics, including a common machine language.

## T

**task.** A basic unit of work to be accomplished by a device or an operator.

**tensile strength.** A measure of the force that the paper forms can withstand without tearing.

**test mode.** The operational mode in which the printer can produce print samples, accept configuration changes, and control traces. When the printer are in test mode, they is not accepting information from the attached controlling computer system. Contrast with *print mode* and *diagnostic mode*.

**text orientation.** The position of text as a combination of print direction and baseline direction.

**tie.** The interval between cuts of a perforation. See also *perforation*.

**toner.** The material that forms the image on the paper.

**trace.** (1) A record of the running of a computer program. It exhibits the sequences in which the instructions were executed. (2) To record a series of

events as they occur. (3) In the printer, a service representative and customer analysis procedure.

**tractor.** The mechanism that controls movement of continuous forms by way of holes (see *tractor holes*).

**tractor holes.** The holes in the side margins on continuous forms. When placed on the tractor pins, the holes maintain printer alignment and registration, and control the movement of the paper.

**Two-Channel Switch.** A feature, when System/370 or ESCON channel attachment is used, that allows an input or output device to be attached to two channels.

## U

**up fold.** Fanfold forms are alternately folded. When fanfold forms are unfolded and held horizontally, a fold is an up fold if it points up from the horizontal surface.

## V

**variable data.** The data that can vary; for example, the names and addresses in form letters.

**vector graphics.** Computer graphics in which display images are generated from display commands and coordinate data. Contrast with *raster pattern*.

**Virtual Storage Extended (VSE).** An operating system that is an extension of Disk Operating System/Virtual Storage.

**Virtual Storage Extended/Advanced Functions (VSE/AF).** The minimum operating system support for a VSE-controlled installation.

**void.** (1) A missing part of the printed character. (2) A missing piece of a continuous form.



---

# Index

## A

- abbreviations 69
- access clearance 21
- acronyms 69
- application, color 33
- application, environment 7
- application programmer 14
- attachment 5
- attachment, host 6
- auto load 4
- availability 7
- available color 29

## B

- bitmaps 36
- black bitmaps 36

## C

- cable locations 21
- characteristics 3
- clearances, service 21
- color 1
  - bitmaps 36
  - black bitmaps 36
  - correct side 44, 46
  - coverage 29
  - highlight 1, 29
  - highlight availability 32
  - ink availability 32
  - printing 1
  - registration 47
- color application 33
- components, system 6
- configuration, system 2
- configurations 8
- connection, umbilical 52
- connector 19
  - electrical 20
  - power 19
  - requirements 20
- considerations, environmental 50
- control, power 6
- control, preheat 3
- Control panel assembly 4
- control unit dimensions and weight 21
- coverage, color 29
- coverage, percentage 6

## D

- description, product 1
- design worksheet 61
- development concepts 37
- dimensions, printer and control unit 21
- dimensions and weight 21

## E

- environment 7, 18
- environmental considerations 50

- environmental requirements 17
- error log 7

## F

- forms 45
  - loading duplex 45
  - loading simplex 45
- forms handling 4
- forms path 3

## G

- glossary 73

## H

- handling forms 4
- heat output 18
- host attachment 6
- host verification 43
- humidity 17

## I

- improve registration 49
- ink 3
- Installation 23
- installation planning 24
- intelligent printer data stream 7
- interface, paper 23
- IPDS 7

## L

- layout considerations 21
- levels, sound 18
- loading setups 40
- locations, cables 21

## M

- measurements, clearance 21
- MMC 43
  - keywork high 43
  - keywork low 44
  - mmcid 43
  - semantics 43
  - syntax 43

## N

- noise levels 18

## O

- operator 14
- ordering product 51

organizing the planning team 13  
outlet, vacuum cleaner 20  
output, heat 18

## P

paper interface 23  
performance 7, 17  
physical 20  
    attachment requirements 23  
    layout 20  
    planner 13  
    planning work sheet 25  
physical planning 25  
plan, implementation 14  
planner, physical 13  
planning coordinator 13  
planning team 13  
planning work sheet 24  
post-processing 5  
power cable and receptacle 19  
power control 6  
power requirements 18  
preheat control 3  
print 4  
    area 4  
    head skew 49  
    material 4  
printheads 3  
product description 1  
product ordering 51  
programmer, application 14  
programmer, system 14

## R

raster images 36  
receptacle, electrical 20  
receptacle, power 19  
registration 47  
registration, improve 49  
relative humidity 17  
reliability 7  
requirements 18  
    physical 18  
    physical attachment 23  
    power 18  
    voltage 18  
requirements, installation 23  
requirements, physical 18

## S

security 8  
serviceability 7  
setup 37  
    development concepts 37  
    loading 40  
    prerequisite 40  
    system verification 41  
    verification process 42

Setup worksheet 61  
shipping crate 18  
simplex configuration 9  
skew, print head 49  
sound levels 18  
space requirements 21  
system components 6  
system configuration 2  
system programmer 14

## T

temperature 17  
testing 59  
threading, automatic 4  
traces 7

## U

umbilical 52

## V

vacuum cleaner 20  
ventilation 17  
verification, color side 46  
Verifying ID 43  
voltage requirements 18

## W

weight and dimensions 21  
wiring information 18  
worksheet 61





Printed in the United States of America  
on recycled paper containing 10%  
recovered post-consumer fiber.

6544-5420-01

