

Continuous Forms
Advanced Function Printers



Forms Design Reference

Continuous Forms
Advanced Function Printers



Forms Design Reference

Note!

Before using this information and the product it supports, be sure to read the general information under “Notices” on page v.

Sixth Edition (November 1998)

This edition obsoletes G544-3921-04.

The following paragraph does not apply to any other country where such provisions are inconsistent with local law.

INTERNATIONAL BUSINESS MACHINES CORPORATION PROVIDES THIS PUBLICATION “AS IS” WITHOUT WARRANTY OF ANY KIND, EITHER EXPRESS OR IMPLIED, INCLUDING, BUT NOT LIMITED TO THE IMPLIED WARRANTIES OF MERCHANTABILITY OR FITNESS FOR A PARTICULAR PURPOSE. Some states do not allow disclaimer of express or implied warranties in certain transactions, therefore, this statement may not apply to you.

Changes are made periodically to this publication.

Requests for IBM publications should be made to your IBM representative or to the IBM branch office serving your locality. If you request publications from the address given below, your order will be delayed, because publications are not stocked there.

A Reader’s Comment Form is provided at the back of this publication. If the form has been removed, comments can be sent by fax to 1-800-524-1519, by E-mail to printpub@us.ibm.com, or by mail to:

Department H7FE Building 003G
IBM Printing Systems Company
Information Development
PO Box 1900
Boulder CO USA 80301-9191

IBM may use or distribute whatever information you supply in any way it believes appropriate without incurring any obligation to you.

Visit our home page at: <http://www.printers.ibm.com>

© Copyright International Business Machines Corporation 1991, 1998. All rights reserved.

Note to U.S. Government Users — Documentation related to restricted rights — Use, duplication or disclosure is subject to restrictions set forth in GSA ADP Schedule Contract with IBM Corp.

Contents

Notices	v	Chapter 7. Selecting Special-Purpose Materials.	39
Trademarks	v	Prepunched Forms	39
Communication Statements	vi	Labels	41
Preface	ix	Label Design	41
Audience	ix	Label Types	41
Printers Covered in this Publication	x	Label Design Requirements	42
About This Publication	x	Adhesive	43
Summary of Changes	xi	Face Stock Selection	43
Chapter 1. General Guidelines for Selecting Forms	1	Face Stock Paper	43
Terminology	1	Carrier Material	43
Size	2	Basis Weight and Thickness	43
Print Areas	4	Smoothness	43
Standards and Tolerances	6	Recommendations	43
Page Uniformity	6	Operator Tasks	44
Paper Tolerances	7	Chapter 8. Developing Special Applications	45
Stack Lean	8	Optical Character Recognition Forms	45
Dishing	10	Bar Code Forms	45
Edge Accuracy	12	Colors	46
Perforation and Tractor Hole Accuracy	13	Chapter 9. Testing Forms and Applications	47
Perforation Fold Memory	15	Questions and Answers: Testing Forms and Applications	47
Perforation Embossing	16	What is an Ideal Form and Application?	47
Perforation Strength	16	When Should I Test My Forms and Applications?	47
Packaging	19	What Will Testing Tell Me?	48
Shipping, Storage, and Operating Environment	20	How Do I Evaluate the Test Results?	49
Chapter 2. Paper Recommendations for High-Resolution Printers	21	What Kind of Testing Should I Do?	49
Chapter 3. InfoPrint 62 Forms Specifications	23	Troubleshooting	51
Chapter 4. InfoPrint 3000 Forms Specifications	25	Printing on the Reverse Side	51
Chapter 5. Selecting Paper	27	Chapter 10. Safety Practices	53
Paper Quality	27	Blank Forms	53
Paper Dust Contamination	29	Preprinted Forms	53
Paper Weight and Thickness	29	Electronic Overlays	53
Smoothness	30	Labels	54
Fusing Ability	30	Multipart Carbonless Paper	54
Summary of Paper Selection Recommendations	31	Acronyms and Abbreviations	55
Chapter 6. Selecting Preprinted Forms	35	Glossary	57
General Recommendations	35	Index	65
Vapor Emissions from Preprinted Forms	36	Readers' Comments — We'd Like to Hear from You	69
Electronic Overlays	37		
Forms for Advertising	37		
Forms for Negotiable Documents	37		

Notices

References in this publication to IBM products, programs, or services do not imply that IBM intends to make these available in all countries in which IBM operates. Any reference to an IBM product, program, or service is not intended to state or imply that only that IBM product, program, or service may be used. Any functionally equivalent product, program, or service that does not infringe any of the intellectual property rights of IBM may be used instead of the IBM product, program, or service. The evaluation and verification of operation in conjunction with other products, except those expressly designated by IBM, are the responsibility of the user.

IBM may have patents or pending patent applications covering subject matter in this publication. The furnishing of this publication does not give you any license to these patents. You can send license inquiries, in writing, to the IBM Director of Commercial Relations, IBM Corporation, Purchase, NY 10577, U.S.A.

Trademarks

The following terms used in this publication are trademarks of the IBM Corporation in the United States or other countries or both:

AFCCU and Advanced Function Common Control Unit

AFP and Advanced Function Presentation

AIX®

AIX/6000

BCOCA and Bar Code Object Content Architecture

ESCON®

ES/3090

ES/4381

ES/9000

GDDM

IBM®

IPDS and Intelligent Printer Data Stream

MVS and MVS/SP

OS/2®

PS/2

PSF and Print Services Facility

RISC System/6000®

System/360

System/370

Communication Statements

Federal Communications Commission (FCC) Statement

Note: This equipment has been tested and found to comply with the limits for a Class A digital device, pursuant to Part 15 of the FCC Rules. These limits are designed to provide reasonable protection against harmful interference when the equipment is operated in a commercial environment. This equipment generates, uses, and can radiate radio frequency energy and, if not installed and used in accordance with the instruction manual, may cause harmful interference to radio communications. Operation of this equipment in a residential area is likely to cause harmful interference, in which case the user will be required to correct the interference at his own expense.

Properly shielded and grounded cables and connectors must be used in order to meet FCC emission limits. IBM is not responsible for any radio or television interference caused by using other than recommended cables and connectors or by unauthorized changes or modifications to this equipment. Unauthorized changes or modifications could void the user's authority to operate the equipment.

This device complies with Part 15 of the FCC Rules. Operation is subject to the following two conditions: (1) this device may not cause harmful interference, and (2) this device must accept any interference received, including interference that may cause undesired operation.

Canadian Department of Communications compliance statement: This Class A digital apparatus meets the requirements of the Canadian Interference-Causing Equipment Regulations.

Avis de conformité aux normes du ministère des Communications du Canada: Cet appareil numérique de la classe A respecte toutes les exigences du Règlement sur le matériel brouilleur du Canada.

The United Kingdom Telecommunications Statement of Compliance: This apparatus is approved under the approval No. NS/G/1234/J/100003 for the indirect connections to the public telecommunications systems in the United Kingdom.

Statement for CISPR 22 Edition 2 Compliance: Warning: This is a Class A product. In a domestic environment this product may cause radio interference in which case the user may be required to take adequate measures.

German Conformity Statement:

Dieses Gerät erfüllt die Bedingungen der EN 55022 Klasse A. Für diese Klasse von Geräten gilt folgende Bestimmung nach dem EMVG:

Geräte dürfen an Orten, für die sie nicht ausreichend entstört sind, nur mit besonderer Genehmigung des Bundesministers für Post und Telekommunikation oder des Bundesamtes für Post und Telekommunikation betrieben werden. Die Genehmigung wird erteilt, wenn keine elektromagnetischen Störungen zu erwarten sind.

(Auszug aus dem EMVG vom 9.Nov.92, Para.3, Abs.4)

European Community (EC) Conformity Statement: This product is in conformity with the protection requirements of EC Council Directive 89/336/EEC on the approximation of the laws of the Member States relating to electromagnetic compatibility. IBM cannot accept responsibility for any failure to satisfy the protection requirements resulting from a non-recommended modification of the product, including the fitting of non-IBM option cards.

Shielded Cables (European Statement): Properly shielded and grounded cables and connectors must be used in order to reduce the potential for causing interference to radio and TV communication and to other electrical or electronic equipment. Such cables and connectors are available from IBM authorized dealers. IBM cannot be responsible for any interference caused by using other than recommended cables and connectors.

Japanese VCCI:

この装置は、第一種情報装置（商工業地域において使用されるべき情報装置）で商工業地域での電波障害防止を目的とした情報処理装置等電波障害自主規制協議会（VCCI）基準に適合しております。
従って、住宅地域またはその隣接した地域で使用すると、ラジオ、テレビジョン受信機等に受信障害を与えることがあります。
取扱説明書に従って正しい取り扱いをして下さい。

VCCI

Taiwanese EMC:

警告使用者：
這是甲類的資訊產品，在居住的環境中使用時，可能會造成射頻干擾，在這種情況下，使用者會被要求採取某些適當的對策。

Preface

This publication describes important characteristics of the forms and special-purpose media that can be used with the family of IBM continuous forms printers.

For more information about these printers, refer to the Introduction and Planning Guide for each printer.

A broad range of output supplies is available. Because some supplies work better than others, choosing the most appropriate supplies can help ensure that you get the best possible results from your continuous forms printer. Your printer may require the addition of optional features to accommodate the full range of supplies that are available.

Audience

This publication is for people who order forms and special-purpose materials, such as labels, prepunched paper, or preprinted forms. It also contains information for people who develop applications that use preprinted paper, optical character recognition (OCR), bar codes, or other unusual printed output.

You need not read this reference manual sequentially from front to back. However, if you are responsible for obtaining forms and related output supplies for a continuous forms printer, you should familiarize yourself with all the information that is presented here. Even though the printer is working correctly, it may have problems handling the paper due to poor form characteristics.

Note: The quality of your output depends on the characteristics and quality of the forms and supplies you use.

For standard forms, see "Chapter 5. Selecting Paper" on page 27. For preprinted forms, see "Chapter 6. Selecting Preprinted Forms" on page 35.

Planners and buyers may want to share this document with their form manufacturers or suppliers. This publication contains detailed technical information that can help them determine which of their products will work best for your particular applications. IBM strongly recommends testing any forms prior to purchasing large quantities to assure satisfactory performance.

Printers Covered in this Publication

The following machine types and model types are covered in this publication.

Printer Name	Machine Type	Model Number
IBM 3900 Advanced Function Printer	3900	001
IBM 3900 with Enhanced Print Quality Advanced Function Printer	3900	001
IBM 3900 Wide Advanced Function Printer	3900	0W1, 0W3
IBM 3900 Advanced Function Duplex Printing System	3900	D01, D02
IBM 3900 Advanced Function Wide Duplex Printing System	3900	DW1, DW2
IBM InfoPrint 4000	4000	IS1, IS2, ID1/ID2, ID3/ID4, IR1/IR2, IR3/IR4, DR1/DR2
IBM InfoPrint 3000	3300	ES1, ED1/ED2
IBM InfoPrint 62	4370	002, 003

About This Publication

This publication contains the following chapters:

- “Chapter 1. General Guidelines for Selecting Forms” on page 1 describes general requirements and recommendations that apply to all forms used by continuous forms printers.
- “Chapter 2. Paper Recommendations for High-Resolution Printers” on page 21 provides general paper recommendations for high-resolution printers.
- “Chapter 5. Selecting Paper” on page 27 defines quality, weight, thickness, and other paper characteristics that can affect print quality and performance.
- “Chapter 6. Selecting Preprinted Forms” on page 35 describes factors to consider in selecting papers and inks for preprinted forms.
- “Chapter 7. Selecting Special-Purpose Materials” on page 39 details recommendations and limitations regarding prepunched forms and labels.
- “Chapter 8. Developing Special Applications” on page 45 provides specifications for OCR forms and bar code forms.
- “Chapter 9. Testing Forms and Applications” on page 47 describes techniques for determining if forms are suitable for use with continuous forms printers.
- “Chapter 10. Safety Practices” on page 53 describes health and safety considerations for a variety of paper and preprinted forms.
- “Glossary” on page 57 defines terms used in IBM continuous forms printer documentation.

Summary of Changes

Technical changes are marked by a (1) in the left margin.

Editorial-only changes are not marked.

Changes in this release include:

- Information was added for InfoPrint 3000.
- Corrections and clarifications were made throughout.

Chapter 1. General Guidelines for Selecting Forms

The quality and consistency of performance of IBM continuous forms printers is directly related to the quality and consistency of forms used for printing. This chapter explains important issues to consider when you select forms for your continuous forms printer. Items to consider include:

- Form stock¹
- Size
- Print areas
- Standards and tolerances
- Packaging
- Shipping, storage, and operating environment.

For best performance, use forms that meet the recommendations in this guide. Provide your form vendor with the form criteria outlined in “Summary of Paper Selection Recommendations” on page 31 and request forms that meet these criteria.

You may need to work with your form vendor to optimize some characteristics for your application. IBM strongly recommends testing all forms prior to purchasing large quantities to assure satisfactory performance.

See “Chapter 2. Paper Recommendations for High-Resolution Printers” on page 21 for important information about forms for high-resolution printers.

Terminology

This publication uses familiar terms that also have precise technical meanings. Knowing these technical definitions will help you use and understand the information in this document.

Form refers to a continuous fanfold (box) or roll-feed set of pages on which the printer can print. Forms can be blank paper, preprinted paper, adhesive labels, cards, or any other printable material. *Paper* is a specific fiber-based material used to make forms.

The *forms path* (often referred to as the paper path) is the entire route that forms travel while they are being processed. The forms path usually begins where the forms are loaded, and ends at the stacker or post-processing device. Forms that are threaded through the printer forms path are known as the *forms web*, or the *web*.

Perforation refers to a series of small holes made in a form to serve as an aid in separation. Perforations consist of cuts and ties. A *cut* is where the paper is severed, and a *tie* is the small connection of paper between cuts.

Horizontal perforations separate sheet lengths of continuous forms and are either page perforations or fold perforations. *Page* perforations define the lengths of

1. Refer to “Chapter 5. Selecting Paper” on page 27 or “Chapter 2. Paper Recommendations for High-Resolution Printers” on page 21 for important considerations when selecting paper stock and “Chapter 7. Selecting Special-Purpose Materials” on page 39 when selecting special-purpose materials.

forms; *fold* perforations define the points at which forms are folded for stacking. A page perforation may or may not be a fold perforation, depending on the length of the form. *Running* perforations are vertical and are next to the tractor holes (holes in the side margin). Perforations other than running and fold perforations are referred to as *internal* perforations. These perforation terms are illustrated below.

For definitions of other terms, refer to “Acronyms and Abbreviations” on page 55 and the “Glossary” on page 57. The glossary contains terms that are used in this publication and in other IBM printer documentation.

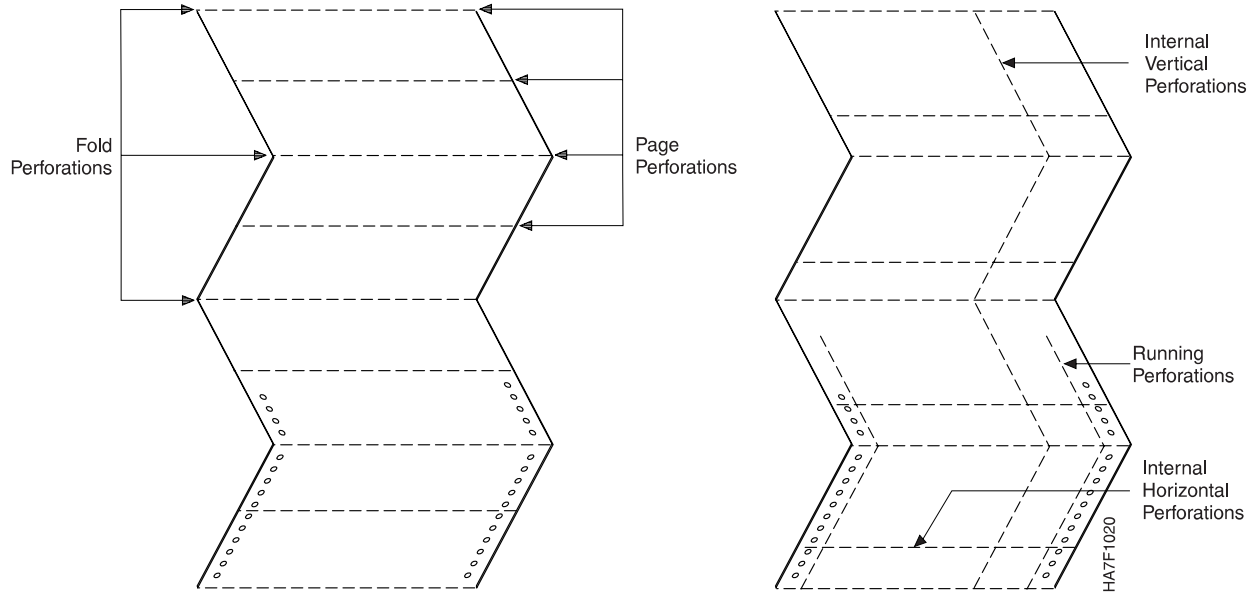

Figure 1. Types of Perforations

Size

Note: The tables below may not include models changed or added after the release of this publication. To verify the paper sizes your printer supports, please review the Introduction and Planning Guide for your printer or consult your marketing representative.

Your continuous forms printer is designed to use either fanfold (box) or roll-feed, single-ply forms with tractor holes in both outside margins. These forms must conform to the width, length, and spacing limits that are defined in the following tables. *Width* refers to the distance between the outer edges, in the tractor-hole-to-tractor-hole direction. *Length* is the distance between horizontal perforations. Always test applications with dimensions not within the ranges that are given in the following tables. See “Chapter 9. Testing Forms and Applications” on page 47 for more information.

Table 1. Required Dimensions for 3900 Models-001, D01, D02 Simplex

Dimension	Minimum		Maximum	
	mm	inches	mm	inches
Width	165 ±3.0	6.5 ±0.118	406 ±4.0	16.0 ±0.157
Length	76.2 ±0.3	3.0 ±0.013	356 ±0.3	14.0 ±0.013
Fold Spacing	178 ±0.3	7.0 ±0.013	356 ±0.3	14.0 ±0.013

Table 2. Required Dimensions for 3900 Models D01, D02 Duplex

Dimension	Minimum		Maximum	
	mm	inches	mm	inches
Width	229 ±3.0	9.0 ±0.118	406 ±4.0	16.0 ±0.157
Length	76.2 ±0.3	3.0 ±0.013	356 ±0.3	14.0 ±0.013
Fold Spacing	178 ±0.3	7.0 ±0.013	356 ±0.3	14.0 ±0.013

Table 3. Required Dimensions for Models 3900 0W1, 0W3, DW1 Simplex

Dimension	Minimum		Maximum	
	mm	inches	mm	inches
Width	229 ±3.0	9.0 ±0.118	457 ±4.0	18.0 ±0.157
Length	76.2 ±0.3	3.0 ±0.013	356 ±0.3	14.0 ±0.013
Fold Spacing	178 ±0.3	7.0 ±0.013	356 ±0.3	14.0 ±0.013

Table 4. Required Dimensions for 3900 Model DW2 Simplex, DW1 and DW2 Duplex

Dimension	Minimum		Maximum	
	mm	inches	mm	inches
Width	305 ±3.0	12.0 ±0.118	457 ±4.0	18.0 ±0.157
Length	76.2 ±0.3	3.0 ±0.013	356 ±0.3	14.0 ±0.013
Fold Spacing	178 ±0.3	7.0 ±0.013	356 ±0.3	14.0 ±0.013

Table 5. Required Dimensions for InfoPrint 4000 Model IR1/IR2, IR3/IR4, and DR1/DR2 Duplex

Dimension	Minimum		Maximum	
	mm	inches	mm	inches
Width	305 ±3.0	12.0 ±0.118	457 ±4.0	18.0 ±0.157
Length	76.2 ±0.3	3.0 ±0.013	356 ±0.3	14.0 ±0.013
Fold Spacing	178 ±0.3	7.0 ±0.013	356 ±0.3	14.0 ±0.013

Table 6. Required Dimensions for InfoPrint 4000 IS1, IS2, ID1/ID2, ID3/ID4

Dimension	Minimum		Maximum	
	mm	inches	mm	inches
Width	204±3.0	8.0±0.118	457 ±4.0	18.0 ±0.157
Length	76.2 ±0.3	3.0 ±0.013	356 ±0.3	14.0 ±0.013
Fold Spacing	178 ±0.3	7.0 ±0.013	356 ±0.3	14.0 ±0.013

Table 7. Required Dimensions for InfoPrint 3000 ES1 and ED1/ED2 Dual Simplex

Dimension	Minimum		Maximum	
	mm	inches	mm	inches
Width	204±3.0	8.0±0.118	457 ±4.0	18.0 ±0.157
Length	76.2 ±0.3	3.0 ±0.013	356 ±0.3	14.0 ±0.013
Fold Spacing	178 ±0.3	7.0 ±0.013	356 ±0.3	14.0 ±0.013

Table 8. Required Dimensions for InfoPrint 3000 ED1/ED2 Duplex

Dimension	Minimum		Maximum	
	mm	inches	mm	inches
Width	229±3.0	9.0±0.118	457 ±4.0	18.0 ±0.157
Length	76.2 ±0.3	3.0 ±0.013	356 ±0.3	14.0 ±0.013
Fold Spacing	178 ±0.3	7.0 ±0.013	356 ±0.3	14.0 ±0.013

Table 9. Required Dimensions for InfoPrint 62 Model

Dimension	Minimum		Maximum	
	mm	inches	mm	inches
Width	178±3.0	7.0±0.118	406±4.0	16.0±0.157
Length (without power stacker)	178±0.3	7.0±0.013	559±0.3	22.0±0.013
Length (with power stacker)	178±0.3	7.0±0.013	305±0.3	12.0±0.013

Notes:

1. Lengths and fold spacing must be in 12.7 mm (0.5 in.) or 8.5 mm (0.3 in.) intervals.
2. Forms shorter than 178 mm (7.0 in.) are printed in multiples and use page (non-folding) perforations to define pages.
3. Form lengths up to 17 inches (such as ISO A3 forms - 11.69 by 16.54 inches) may be printed on the continuous forms printers but cannot be stacked by the printer's stacker. When printing on form lengths greater than 14 inches, the printer's stacker must be disabled, and the printer must have suitable post-processing equipment installed.

Print Areas

Your continuous forms printers can print **to** the perforation; see Figure 2 on page 5. Note that print quality is reduced when printing near a folding perforation, an internal perforation, or any cut in the form. For example, poor toner transfer may occur due to the perforation or fold.

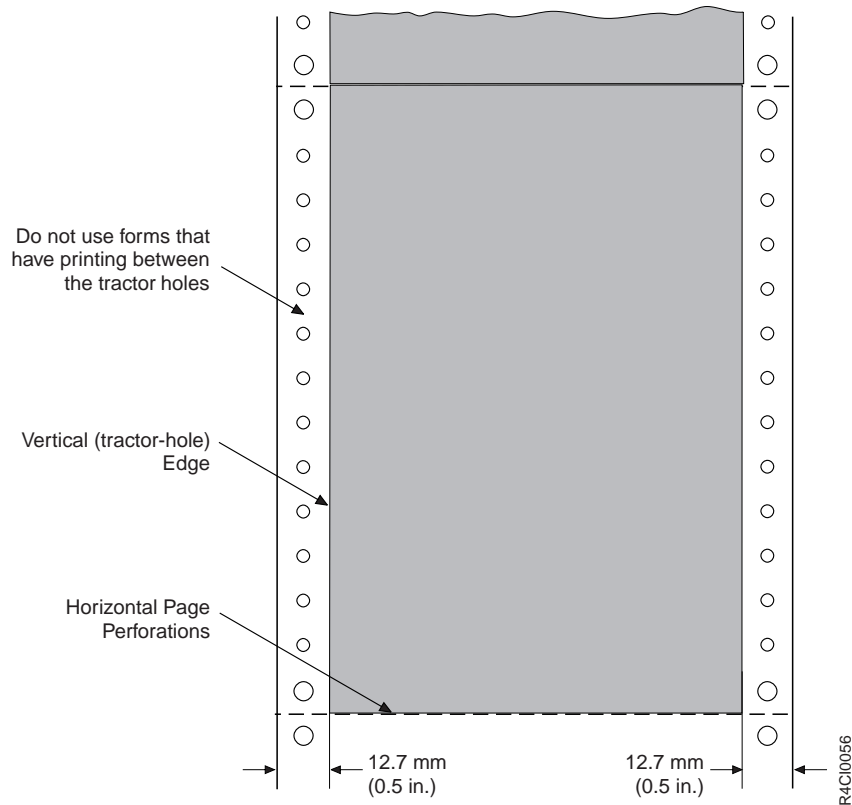

Figure 2. Print Area

Note: Printing on the areas near the perforations is not recommended because print quality may not be acceptable.

To ensure correct operation and print quality, maintain the following distances for the print area:

- From internal and running perforations: 1.27 mm (0.05 in.)
- From folding perforations: for text, 8.5 mm (0.33 in.); for images, 12.7 mm (0.5 in.)
- From binder holes or cuts: 2.54 mm (0.1 in.).

Paper ripple (caused by humidity stress during shipping, storage, or printing) and paper embossing (caused by dull cutting equipment or other paper-handling equipment during form manufacturing) may produce voiding within the print area. This voiding (some of printed text or graphics is not printed) usually occurs near the edges of the print area or adjacent to perforations or holes.

Printing-to-perforation performance is optimum at 18.3° to 23.9°C (65° to 75°F) and 40% to 60% relative humidity. The performance may be significantly degraded at environmental extremes.

Note: To ensure proper printing, two *clear zones* (areas within the tractor-hole strip that contain no printing) are required:

- The first clear zone is 8.13 ± 0.10 mm (0.320 ± 0.004 inches) wide and runs the full length of the form in the process direction. This clear zone is 4.07

± 0.05 mm (0.160 ± 0.002 inches) on either side of the center line of the tractor holes. Printing in this area causes skew sensor errors and your print job can fail.

- In addition, if side1/side2 verification marks are used, there must be a clear zone that is approximately 51 mm (2 inches) from the top of the form and includes the entire width of the tractor strip.

Standards and Tolerances

You can avoid printer problems and operator interventions by using only those forms that meet standards and tolerances that are described in this section. Simple tests are included to help you determine if the forms you select are within the tolerances that are specified for the continuous forms printer. You may want to share this information with your form manufacturers and obtain their assistance in performing these tests.

Page Uniformity

For optimal performance, form pages must be within the tolerances shown in Figure 3 on page 7. To ensure correct printing and form feeding, the two vertical rows of tractor holes must be parallel.

All measurements should be made at $22.8^{\circ} \pm 2.8^{\circ}\text{C}$ ($73^{\circ} \pm 5^{\circ}\text{F}$) and at $50\% \pm 5\%$ relative humidity.

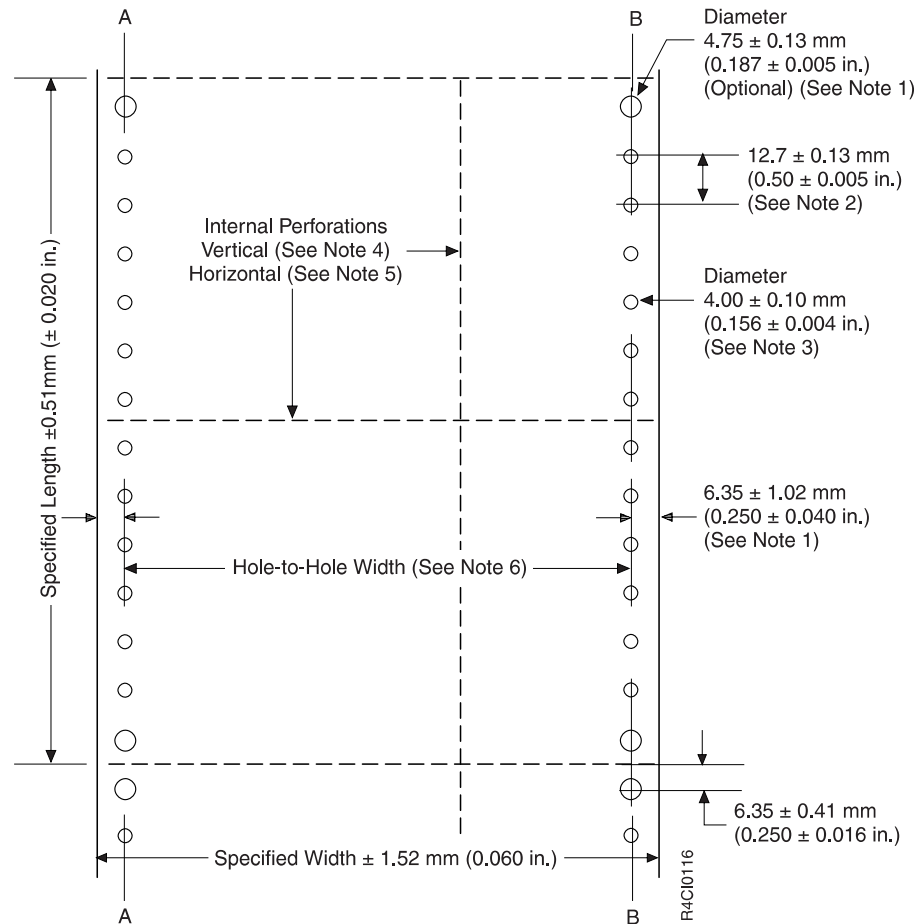

Figure 3. Paper dimension and perforation requirements. See “Paper Tolerances”. The accumulation of individual tolerances should not exceed the specified width tolerance of ± 1.52 mm (± 0.060 in.).

Paper Tolerances

1. The center of the tractor holes in the left margin should be lined up within 0.13 mm (0.005 in.) of the A axis. The center of the tractor holes in the right margin should be lined up within 0.13 mm (0.005 in.) of the B axis.
2. Spacing from any tractor hole to another should be the correct multiple of the adjacent hole space of 12.7 ± 0.13 mm (0.50 ± 0.005 in.).
3. Serrated feeding holes with a 3.86 mm (0.152 in.) inside diameter and a 4.37 mm (0.177 in.) maximum outside diameter are preferred. Continuous forms with a tractor-hole diameter of 4.0 ± 0.10 mm (0.156 ± 0.004 in.) in both right and left margins are acceptable.
4. Vertical perforations should not be closer than 25.4 mm (1.0 in.) to the edge of the form to avoid form breaks and jams.
5. For optimal form stacking, internal horizontal perforations should be at least 50.8 mm (2.0 in.) from the top or bottom of the form. To minimize premature folding in the stacker, any internal horizontal perforations should be stronger than the between-forms perforations.
6. Hole-to-hole widths and their tolerances are shown in Table 10 on page 8.

Table 10. Hole Tolerances

Hole-to-Hole Widths (width – 12.7 mm [0.5 in.])		Tolerances		Single-Pack Variation	
mm	inches	±mm	±inches	±mm	±inches
<203.2	<8.0	1.17	0.046	0.66	0.026
203.2 to 254.0	8.0 to 10.0	1.27	0.050	0.76	0.030
254.0 to 304.8	10.0 to 12.0	1.37	0.054	0.86	0.034
>304.8	>12.0	1.50	0.059	0.99	0.039

The tolerances are based on a flat tolerance of 0.76 mm (0.030 in.) plus 0.051 mm (0.002 in.) for each inch width of the maximum hole-to-hole width.

For fanfold (box) forms, the single or roll pack variation applies to the variance expected within a single pack (one carton or roll) of forms. A form's tolerance limit may vary within an order or from shipment to shipment. But within one carton or roll of forms, the variation should not be greater than the single-pack variation noted for the width used.

Stack Lean

The following information applies to fanfold (box) forms only. This information does not apply to continuous roll-feed forms.

A stack of new forms should be square and not lean to either side. There are two methods for testing stack lean: one for unpackaged forms and another for packaged forms. IBM can supply a gauge (part number 4792992) for measuring the slope of a form stack. Contact your IBM marketing representative for information about ordering this gauge.

Testing Before Packaging

The stack should not exceed a slope from the vertical greater than 76 mm per 305 mm (3 in. per 12 in.) of stack height, as shown in Figure 4 on page 9. The stack lean test procedure for forms that have not been packaged is as follows:

1. Ruffle 51 mm (2 in.) of paper.
2. Ruffle all four edges several times.
3. Measure the slope from the vertical, which should not exceed 13 mm for every 51 mm (0.50 in. for every 2 in.) of stack height.

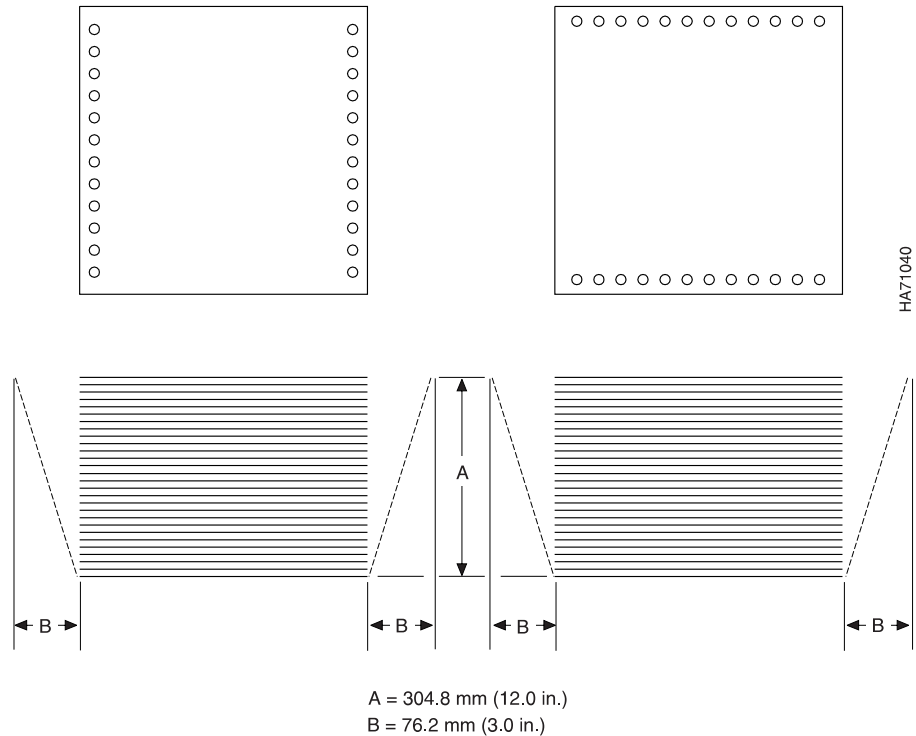

Figure 4. Stack Lean Test for Unpackaged Forms

If the stack lean exceeds the angle of the gauge, it exceeds the InfoPrint 4000 and 3900 printer lean requirements of 76 mm in 305 mm (3 in. in 12 in.) of stack height and significantly reduces stacker performance.

Testing After Packaging

After forms are packaged, they often have folds that are force-folded during packaging and are not folded on the actual perforation. The stack lean test procedure for forms that have been packaged is as follows:

1. Obtain a sample of unprocessed and undamaged paper (not less than 40 pages).
2. Loosely back-fold the sample (invert the existing folds), and carefully break the folds along the perforation center.
3. Without compressing the folds, place the loosely back-folded stack on a flat surface (see Figure 5 on page 10).
4. With your fingers, compress the stack as flat as possible on the top. Do not induce lean. Keep a downward pressure on the stack until measurements are complete.
5. Select the area of worst lean along one side and apply finger pressure to remove all the air between the sheets. Use the gauge (PN 4792992, supplied by IBM) to test the stack lean as shown in Figure 5 on page 10.
6. Repeat steps 4 and 5 for the adjacent side of the stack. Both side and fold edges of the stack must be checked.

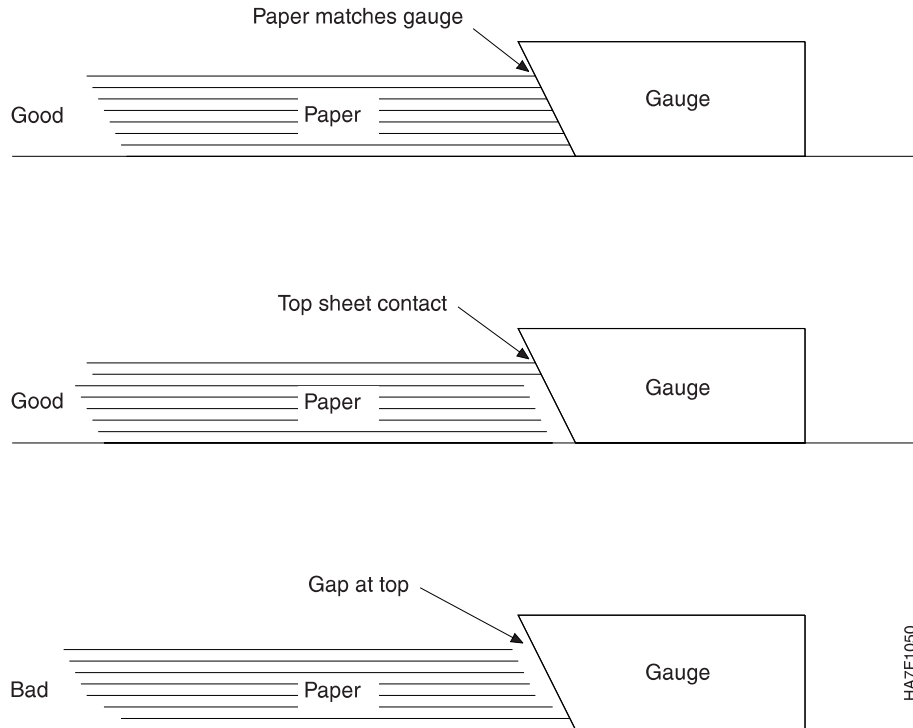

Figure 5. Stack Lean Test for Packaged Forms

If the stack lean exceeds the angle of the gauge, it exceeds the InfoPrint 4000 and 3900 printer lean requirements of 76 mm in 305 mm (3 in. in 12 in.) of stack height and significantly reduces stacker performance.

Dishing

The following information applies to fanfold (box) forms only. This information does not apply to continuous roll-feed forms.

Dishing refers to the curve a stack of forms takes when folded or refolded at the fold perforations. Excessive dishing significantly reduces stacker performance. Test both new forms and forms that have been processed by the InfoPrint 4000 or 3900 printer to determine dishing amounts.

New Forms

Figure 6 on page 11 shows the method for measuring dishing for new forms. Dishing should not exceed 0.067 times the stack height. For example:

- For a stack 305 mm (12 in.) high, dishing should not exceed 20 mm (0.8 in.).
- For a stack 229 mm (9 in.) high, dishing should not exceed 15 mm (0.6 in.).

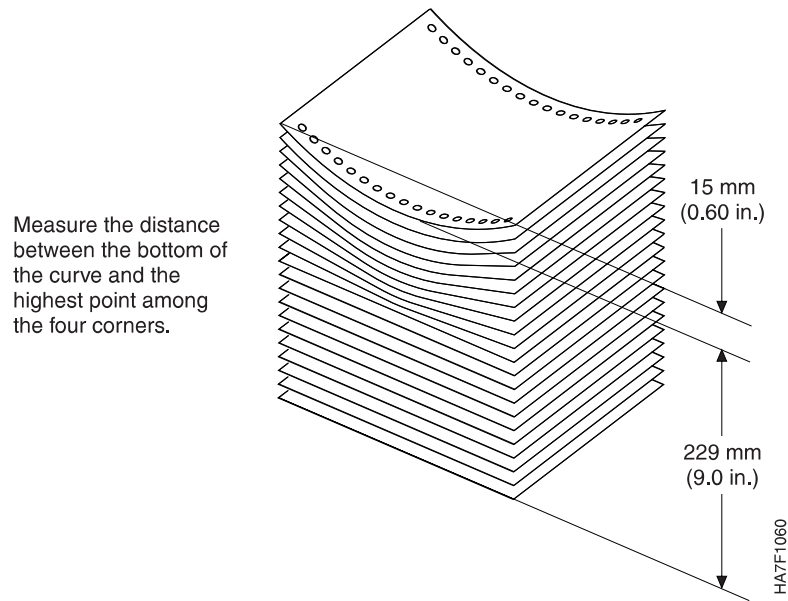

Figure 6. Dishing Effects for New Forms

Dishing often results when the manufacturer uses dull or incorrectly aligned paper cutters to cut page perforations.

Processed Forms

Figure 7 shows the method for measuring dishing for processed forms. Dishing should not exceed 0.137 times the stack height. For example:

- For a stack 241 mm (9.5 in.) high, dishing should not exceed 33 mm (1.3 in.).
- For a stack 305 mm (12 in.) high, dishing should not exceed 41 mm (1.6 in.).

The dishing effect is generally greater on processed forms than on new forms. The

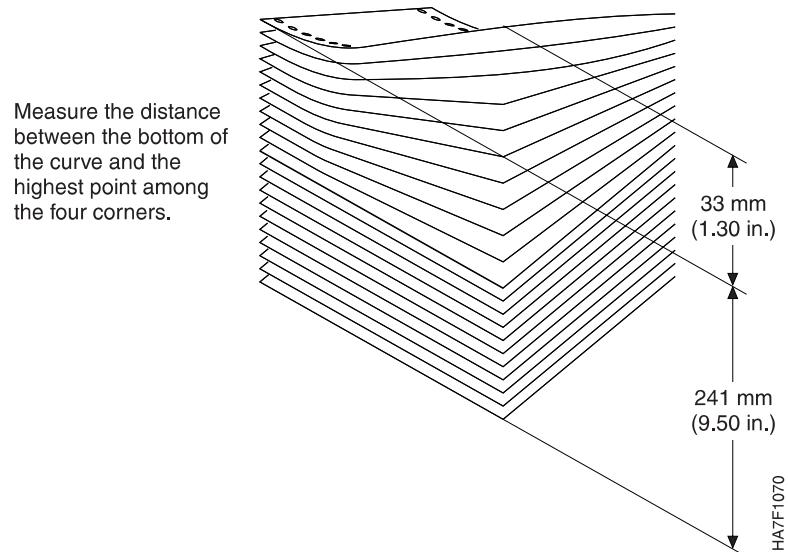

Figure 7. Dishing Effects for Processed Forms

severity of dishing depends on the quality of the forms. The following reasons may contribute to the dishing effect:

- Heat from the high-temperature fusing station reduces the folding memory of the page perforations. See “Perforation Fold Memory” on page 15 for more information.
- Heat from the high-temperature fusing station causes uneven shrinking of the form and distorts the shape of the stack (as shown in Figure 7 on page 11).

Edge Accuracy

The following information applies to both fanfold (box) and continuous roll-feed forms.

Edge accuracy refers to the accuracy with which tractor holes are drilled along the edges of the forms. Inaccurately drilled holes significantly reduce paper-feed performance through the printer.

To test edge accuracy:

1. Tear two lengths of forms, each about 2 meters (7 foot) long, from the stack.
2. Place the two lengths on top of each other on a flat surface. Match the tractor holes of both edges of the top sheet to those of the bottom sheet at one end of the forms.
3. At the other end of the forms, measure the distance from the tractor holes of the top sheet to those of the bottom sheet, as shown in Figure 8. The distances must not be greater than shown.

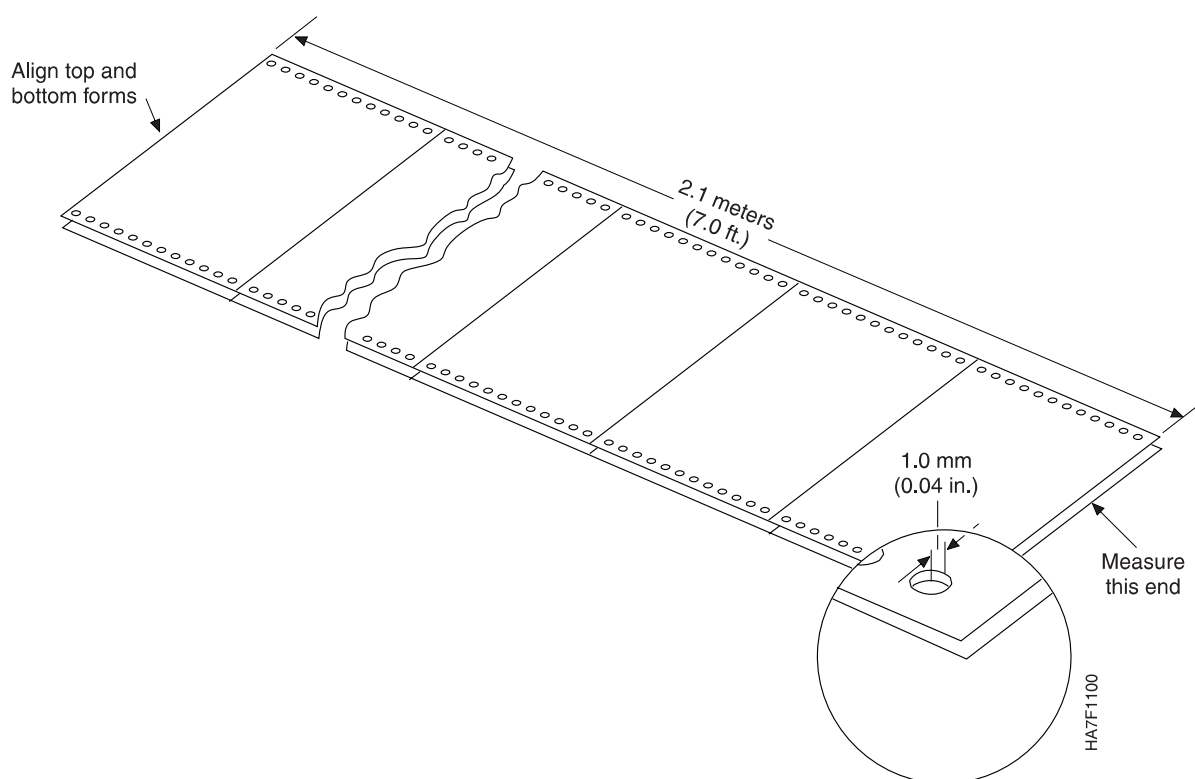

Figure 8. Edge Accuracy

Perforation and Tractor Hole Accuracy

The following information applies to both fanfold (box) and continuous roll-feed forms.

Perforation accuracy refers to the accuracy with which page and fold perforations are cut, perpendicular to the edge of the page. Inaccurately-cut perforations affect form folding and may significantly reduce performance.

Tractor hole accuracy refers to the accuracy with which tractor holes are punched. Inaccurately-punched tractor holes affect form feeding and may significantly reduce printer performance.

To check perforation and tractor hole accuracy, do the following:

1. Tear an even number of continuous sheets totaling about 2.8 meters (9 feet) from the stack or roll.
2. If the sheets are perforated, fold them at the middle page perforation and place the first sheet over the last sheet.
If the sheets are not perforated, fold the sheets in half with the ends together and form a crease. The non-perforated, folded edge must be creased such that the folded edge is 6.35 mm (0.25 in.) from the tractor holes.
3. Measure the distance from either the edge or the tractor hole of the first sheet to those on the last sheet, as shown in Figure 9 on page 14.
 - a. The first tractor holes (top and bottom) after the fold should be aligned, with no offset.
 - b. In **any** given 305 mm (12 in.), the distance between perforations or tractor hole edges must not exceed 0.25 mm (0.01 in.).
 - c. The distances at the opposite end (the open end) must not exceed 0.5 mm (0.02 in.).
4. Refer to Figure 9 on page 14 and measure along each edge to verify that in **any** 305 mm (12 in.) of forms, the distance from either the edge of the tractor holes or the page perforations on the top sheet to the edge of the holes or the page perforations on the bottom sheet does not exceed 0.25 mm (0.01 in.).
5. It is also necessary to ensure that the perforations and tractor holes on both edges of the forms are cut accurately and are not skewed.
 - a. Unfold the sheets you folded in step 2.
 - b. Refer to Figure 10 on page 15 and fold the sheets lengthwise. Measure the page perforations and tractor holes of the two edges as shown.
 - c. The distances between the perforations or the tractor hole edges must not exceed 0.25 mm (0.01 in.) in **any** given 305 mm (12 in.) or 0.5 mm (0.02 in.) over the full length (2.8 meters (9 ft.)).

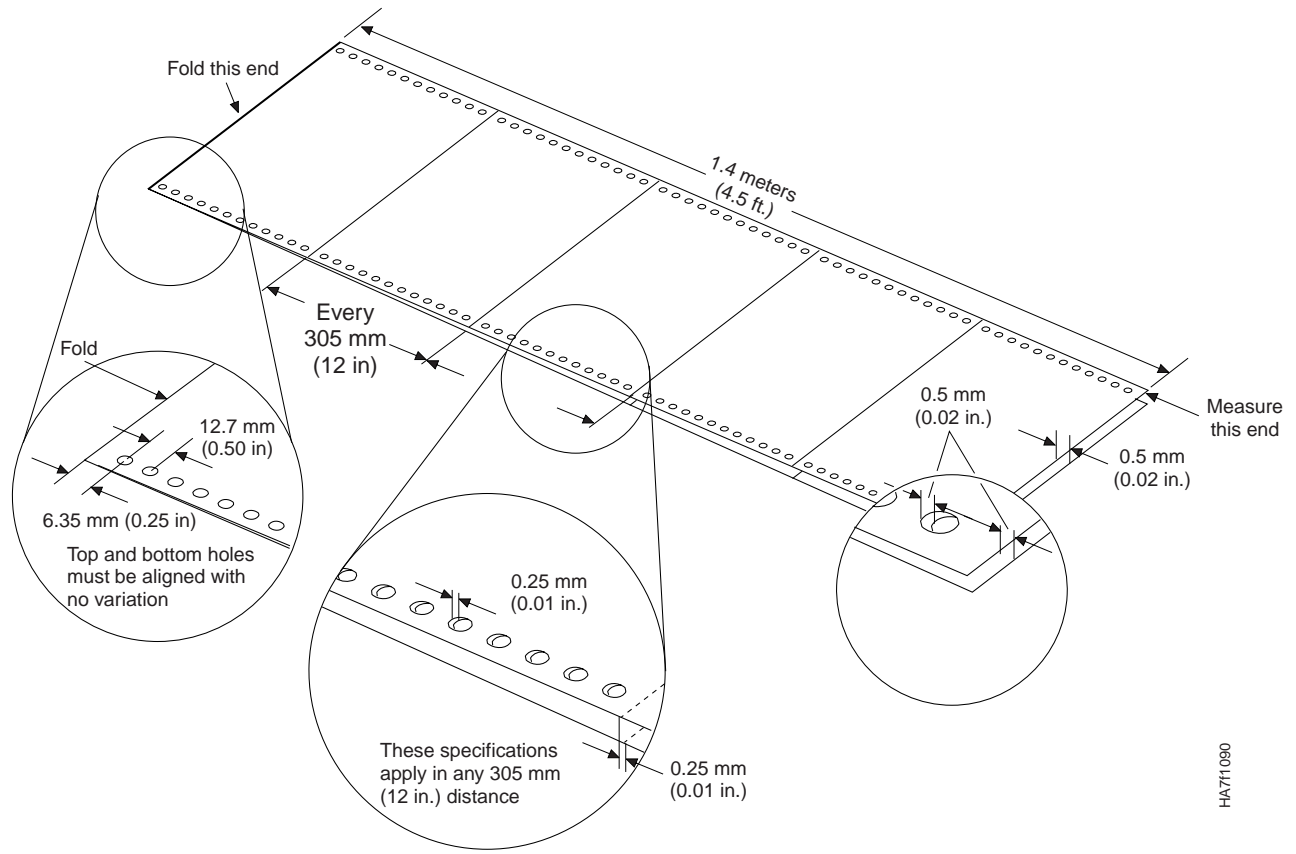

HA711090

Figure 9. Perforation Accuracy

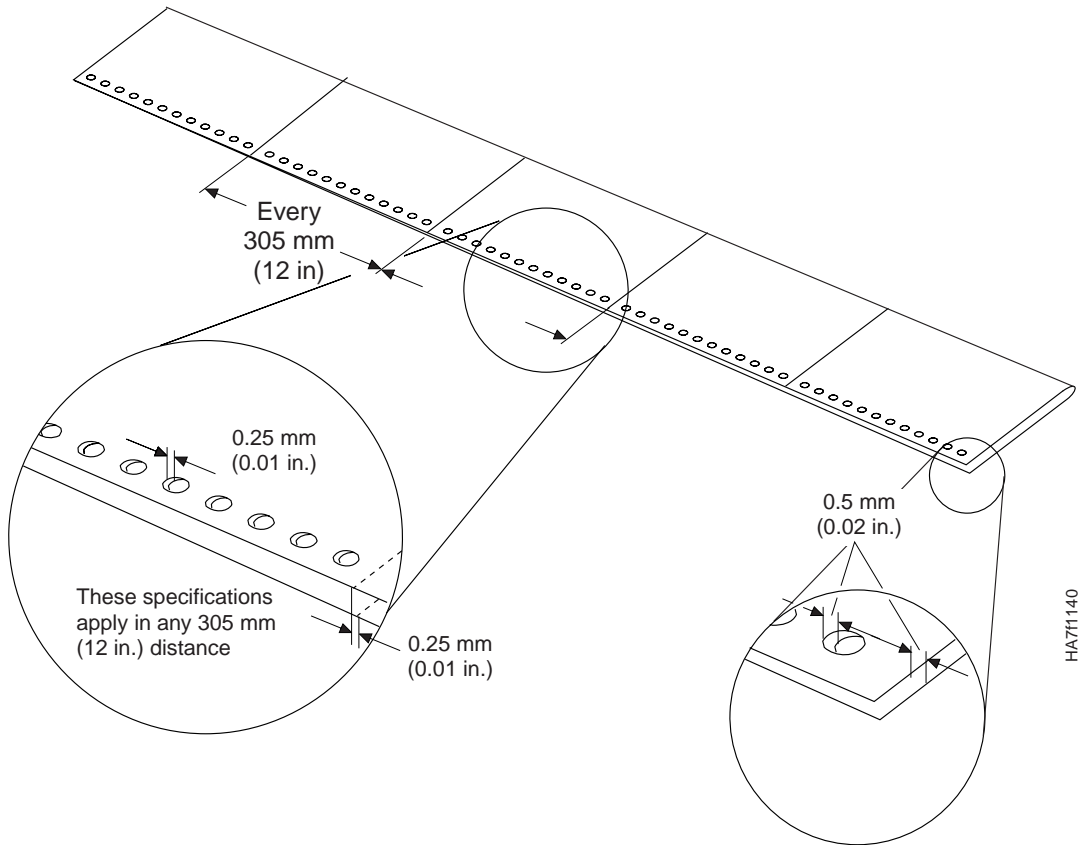

Figure 10. Perforation Accuracy — Edge to Edge

Perforation Fold Memory

The following information applies to fanfold (box) forms only. This information does not apply to continuous roll-feed forms.

Fold memory is the ability of a stack of forms to refold after being processed by the printer. Uneven folds significantly reduce stacker performance. To check the fold memory of a page perforation:

1. Lift the first five or ten sheets of the forms stack, as shown in Figure 11.
2. Ensure that folds are uniform at all fold perforations.

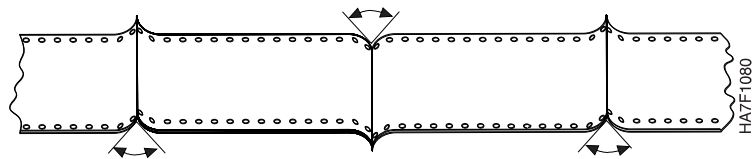

Figure 11. Fold Memory

The following note applies to both fanfold (box) and continuous roll-feed forms.

Note: Form lengths up to 17 inches (such as ISO A3 forms - 11.69 by 16.54 inches) may be printed on the continuous forms printer but cannot be stacked by

the printer's stacker. When printing on form lengths greater than 14 inches, the printer's stacker must be disabled. The printer must have suitable post-processing equipment installed.

Duplex printing with boxed paper may require post-processing equipment. Fold memory may be lost after going through two engines. Perform the fold memory test with paper that has been processed in duplex to determine if post-processing equipment is needed.

Perforation Embossing

The following information applies to both fanfold (box) and continuous roll-feed forms.

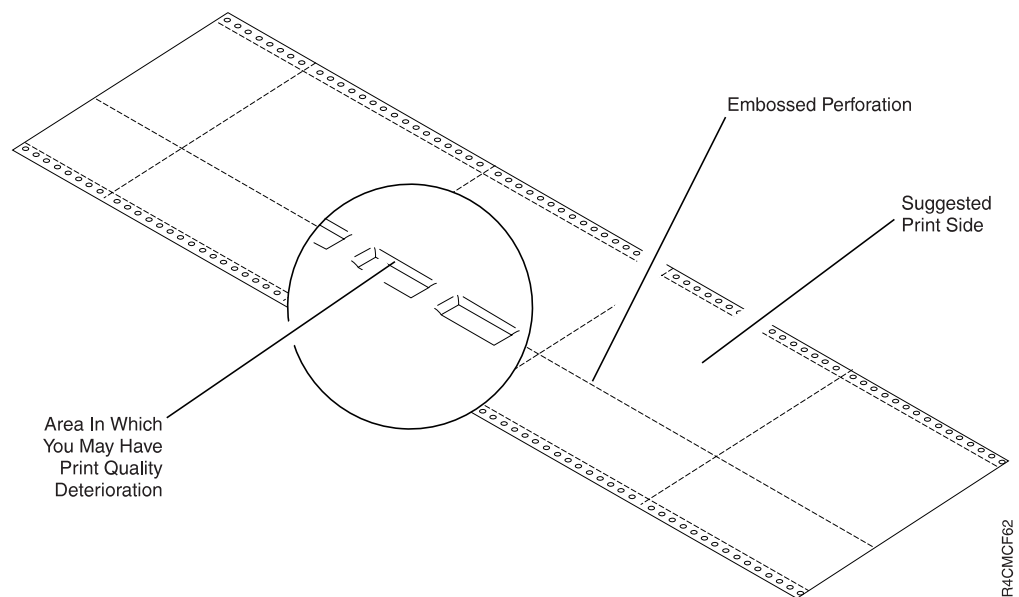

Figure 12. Perforation Embossing

Perforation embossing around the cuts and ties of internal, non-folded perforations resulting from cutting and paper-handling equipment can cause print quality to deteriorate near the embossing. Generally, this is less noticeable when the embossed (raised) surface of the form is *not* the print side. If some deterioration is noticed near perforation embossing, turning over the form in the printer input area may improve print quality (this is valid for duplex systems running in simplex mode). Avoid printing in this area. See "Print Areas" on page 4 for more information.

Note: Printing on the areas near the perforations is not recommended because print quality may not be acceptable.

Perforation Strength

The following information applies to both fanfold (box) and continuous roll-feed forms.

Perforations consist of cuts and ties. A *cut* is where the paper is severed, and a *tie* is the small connection of paper between cuts. The relative length of each

determines the strength of the perforation. Weak perforations can break and cause feeding or refolding problems. Overly strong perforations may not refold reliably. See "Perforation Fold Memory" on page 15 for more information.

Internal perforations should be stronger than fold perforations; otherwise, mis-folds may occur. For internal perforations, use at least:

- 4.7 cuts per cm (12 cuts per in.)
- 0.81 mm (0.032 in.) tie length.

Requirements for perforation characteristics vary according to perforation type:

- *Page Perforation, Folded*

Tensile Strength:

0.7 to 2.5 kN per linear meter (4 to 14 pounds per linear inch)

Tie Minimum:

0.8 mm

Cut Maximum:

3 × tie-length

- *Page Perforation, Nonfolded*

Tensile Strength:

0.9 to 2.7 kN per linear meter (5 to 15 pounds per linear inch)

Tie Minimum:

0.8 mm

Cut Maximum:

3 × tie-length

- *Internal Perforation, Vertical*

Tensile Strength:

0.7 to 2.5 kN per linear meter (4 to 14 pounds per linear inch)

Tie Minimum:

0.8 mm

Cut Maximum:

3 × tie-length

Internal vertical perforations must be at least 50.8 mm (2 in.) from page perforations and at least 25.4 mm (1.0 in.) from form edges to prevent form breaks and jams.

- *Internal Perforation, Horizontal*

Tensile Strength:

0.9 to 2.7 kN per linear meter (5 to 15 pounds per linear inch)

Tie Minimum:

0.8 mm

Cut Maximum:

3 × tie-length

Internal horizontal perforations must be at least 50.8 mm (2 in.) from the top and bottom page perforations to prevent errors.

- *Running Perforation*

Forms with running perforations are *not* recommended for use with continuous forms printers. If you choose to use forms with running perforations, the

running perforations should be along both vertical edges. Forms with running perforations along only one edge may cause errors.

- **All Perforations**

To prevent paper jams, misfeeds, unreliable refolding fanfold forms in stacker, and tearing, use only forms that have:

- Full ties at each perforation edge and cross ties at perforation intersections to help prevent web tears.
- Perforation cuts made from the front surface of the form. Simplex applications for duplex print on printer 1 first.
- Perforations that are cut cleanly and are not embossed. A dull cutting wheel embosses instead of cuts.

The number and strength of a form’s perforations can affect the stacking of fanfold (box) forms in the stacker. If there are too many internal perforations, or if they are too weak, form stiffness may be reduced to a point where the paper does not stack fanfold forms in the stacker reliably. This is especially true with 60 to 72 g/m² (16 to 19 pound) paper.

Table 11 lists recommended form length, paper weight, and perforation information. Using forms that fit these criteria will ensure reliable operation.

Table 11. Recommendations for Reliable Stacking for Fanfold Forms in Simplex

Page Length		Form Weight		Maximum Horizontal Perforations	Maximum Vertical Perforations
mm	inches	g/m ²	pounds		
76.2 to 139.7	3.0 to 5.5	60 to 72	16 to 19	Not Recommended	Not Recommended
		75 to 160	20 to 42	Not Recommended	3
152.4 to 165.1	6.0 to 6.5	60 to 72	16 to 19	1	Not Recommended
		75 to 160	20 to 42	1	3
177.8 to 355.6	7.0 to 14.0	60 to 72	16 to 19	1 (see note)	3 (see note)
		75 to 160	20 to 42	2	3

Note: One horizontal or up to three vertical perforations can be used. Thoroughly test the forms for reliable operation before using them for production jobs.

For best performance, use forms that meet the recommendations in this guide. Provide your form vendor with the form criteria outlined in “Summary of Paper Selection Recommendations” on page 31 and request forms that meet these criteria.

You may need to work with your form vendor to optimize some characteristics for your application.

Perforation Strength Testing

This section describes IBM’s method for testing vertical and horizontal perforations (folding and internal). It includes the equipment needed, the procedure, and the references that contain the evaluation criteria.

Test Equipment:

- Pendulum Type (Schopper-700)

- Load Cell Type (Instron-TM).

The equipment listed for these tests is not required; you may use equipment that provides equivalent functions.

Note: To correlate test equipment, use *Collaborative Reference Program for Paper*, U.S. Department of Commerce.

Suggestions for Testing:

1. Test 25.4 mm (1 in.) samples from each perforation produced by one revolution of the perforation cylinder (15 mm test samples can be used in IBM World Trade Corporation).
2. Select test samples from the right side, center, and left side of a full perforation.
3. Before testing, condition the samples for 8 to 12 hours at 18.3° to 23.9°C (65° to 75°F) and at 50% ($\pm 10\%$) relative humidity.
4. Place the test sample midway and parallel to the jaws of the test equipment.

Test References:

- *Technical Association of Pulp and Paper Industry (TAPPI) Standard, T404 (U.S.)*
- *American Society for Testing Materials (ASTM) Standards*
- *International Organization for Standardization, ISO 1924 (WTC).*

Packaging

The following information applies to fanfold (box) forms only. This information does not apply to continuous roll-feed forms.

Cartons used for shipping forms should contain top and bottom packing to hold the stack of forms firmly in the carton and to prevent damage during handling. This ensures that forms are flat and not damaged at the edges or folds. Avoid using forms with partial breaks in perforations or manufacturers' splices within the paper. To avoid tearing webs and to avoid drag, forms should feed freely with sufficient air around the sides of the forms. This can be accomplished several ways:

- Use zip-open cartons whenever possible.
- For cartons without side packing, remove forms from the carton and place them in the forms input area.
- For cartons with side packing, remove the packing from the carton before threading forms through the printer. The recommended minimum thickness of the packing is 4.8 mm (0.19 in.).
- Cut cartons carefully to avoid cutting the forms inside.
- Ensure that cartons do not interfere with the end-of-form sensor beam that is located about 406 mm (16 in.) above the forms input area.
- Labels must be packaged in inner liner plastic bags. Labels (because of multiple layers) are more susceptible to environmental changes.

Cartons should be tightly closed with no open edges that could allow the forms to absorb moisture unevenly. If forms are to be shipped, stored, or printed in an environment outside the recommended range described in "Shipping, Storage, and Operating Environment" on page 20, place a moisture barrier around each carton or group of cartons. Changes in moisture can reduce print quality, change fusing characteristics, and cause paper jams, misfeeds, unreliable folding, wrinkling, moisture droplets in the printer, and form tearing.

If your printer performance is satisfactory, do not change your paper packaging and storage techniques.

Shipping, Storage, and Operating Environment

The following information applies to both fanfold (box) and continuous roll-feed forms.

Keep forms in their sealed shipping container (the box or wrapped roll) until they are loaded into the printer. The sealed shipping container lessens moisture absorption during shipment from the supplier and during storage. Variations in temperature and humidity affect paper size, weight, and flatness, which in turn affect print quality and printer performance.

Store the sealed shipping containers off the floor (on a pallet, for example). In the case of fanfold forms, in most cases, you can stack boxes up to six high, with each box squarely set on the one underneath. Do not place additional weight on the stack. When stacking boxes, consider the strength and stability of the boxes and the weight of the paper.

Your continuous forms printer can operate in an environment of 16.0° to 29.0°C (60.8° to 84.2°F) and a relative humidity of 20% to 80%. Expect degraded performance outside this range. The best forms processing performance is achieved at 18.4° to 23.8°C (65° to 75°F) and a relative humidity of 40% to 60%. This is also the best condition for storing forms.

Note: IBM recommends storing the forms in the same environment that the printer will be operating for 72 hours or more before using the forms.

The maximum temperature to which forms should be exposed is 43.3°C (110°F), with relative humidity limits of 20% to 80%. Before using forms that are exposed to temperature extremes, allow them to acclimate in their sealed shipping container at the recommended temperatures for at least 72 hours.

The extended range of humidity limits in which the printer can operate (outside the recommended values) can be an adverse environment for storing forms. When this is the case, the forms should be moved to the printer work area shortly before use so that they can be printed on within a half hour.

Manufacturers strive to produce forms with uniform moisture content. Changes in moisture content during shipping, storage, and printing cause forms to expand and contract. This can cause permanent physical damage to the forms. Uneven moisture changes within the forms web can reduce form performance and print quality in the continuous forms printer. If the paper is shipped or stored in an environment where the relative humidity is outside the guidelines, place a moisture barrier around each shipping container or group of containers. A moisture barrier is not recommended for preprinted forms, because it could have an adverse effect on the drying and curing of the printing ink.

Note: If opened or unprotected paper sits for long periods of time (for example, overnight) in environments that exceed 60% relative humidity, the moisture that is absorbed by the paper may cause print quality problems. If this happens, remove a portion of the forms from the top of the box or about 25 mm (1 inch) of paper from the roll and continue. If the problem persists, you should try another box or roll of forms.

Chapter 2. Paper Recommendations for High-Resolution Printers

Various IBM InfoPrint printers print with a resolution greater than 300 pel. (The InfoPrint 4000 Model IR1/IR2, which prints with a resolution of 600 pel, is one such printing system.) For the purposes of this document, any printer that prints with a resolution greater than 300 pel is considered a high-resolution printer. Quality paper supplies must be used in high-resolution printers to ensure excellent print quality. This section provides paper recommendations for achieving the performance that these high-resolution printers are designed to provide. The recommendations in this section are in addition to the ones that are covered in "Chapter 5. Selecting Paper" on page 27.

To ensure that the paper you purchase for use on high-resolution printers is suitable for your application, the following is strongly recommended:

- Request the assistance of your paper supplier to select the proper paper.
- Test your application on a sample of a proposed paper prior to ordering large quantities.

The following paper parameters have been found to be very important for achieving the best possible print quality in high-resolution printers:

- Paper formation
- Uniformity of the following properties across the page:
 - Electrostatic properties
 - Moisture content
 - Paper smoothness.

Note: Paper samples from several paper vendors have been tested by IBM on high-resolution printers. Print quality using the tested papers was considered good. Ask your IBM marketing representative for specific paper vendor recommendations to ensure that your printers produce the best possible print quality for your applications.

Table 12 on page 22 provides information on form smoothness for high-resolution printers.

Table 12. Form Smoothness - High-Resolution Printers

Type	Recommended Smoothness (Sheffield Units)	Typical Application
16 lb. high-bulk bond paper	200 +	<i>Not Recommended</i>
16 or 18 lb. high-bulk bond paper	70 to 100	Internal Reports
20 lb. bond paper	70 to 100	Internal reports
20 lb. bond paper	70 to 100	Statements/proposals Invoices/bills
20 lb. specialty paper	70 to 100	Quality documents
Note: Test the form selected for each application using the appropriate application before ordering large quantities of the form.		

Chapter 3. InfoPrint 62 Forms Specifications

The InfoPrint 62 printer can print on a wide variety of media. The supported media includes:

- Fanfold paper
- Pressure sensitive paper (polyester, polypropylene)
- Special purpose labels
- Vinyl

Table 13. InfoPrint 62 — Forms Specifications

Specification	Minimum	Maximum
Length (process direction)	7.0 inches (177.8 mm)	22 inches (558.8 mm)
Length (with power stacker)	7.0 inches (177.8 mm)	12 inches (304.8 mm)
Width	7.0 inches (177.8 mm)	16.0 inches (406.4 mm)
Weight - Bond	17 lb/ream (64 g/m ²)	44 lb/ream (165 g/m ²)
Weight - Letter Basis	17 lb/ream (64 g/m ²)	54 lb/ream (204 g/m ²)
Weight - Label	44 lb/ream (71 g/m ²)	125 lb/ream (204 g/m ²)

See Table 9 on page 4 for additional forms specifications for InfoPrint 62 printers.

Chapter 4. InfoPrint 3000 Forms Specifications

The InfoPrint 3000 printer can print on a wide variety of media. The supported media includes:

- Fanfold paper
- Pressure sensitive paper (polyester)
- Labels

Note: IBM recommends that you contact your IBM Marketing Representative to discuss your label requirements. It is also recommended that you have IBM test or review the labels you intend to use before you order large amounts.

For further information on forms specifications for the InfoPrint 3000, see Table 7 on page 4 and Table 8 on page 4.

Chapter 5. Selecting Paper

This chapter explains what you need to consider when you select paper and paper-based forms for use in an IBM continuous forms printer, including:

- Quality
- Weight and thickness
- Fusing ability
- Smoothness
- Summary of paper selection recommendations.

Note: *Form* refers to either a continuous fanfold stack (box) of pages or a continuous roll of pages. *Paper* refers to a fiber-based material that is used to make forms. IBM strongly recommends testing any forms prior to purchasing large quantities to assure satisfactory performance.

For information about preprinted forms, see “Chapter 6. Selecting Preprinted Forms” on page 35.

Paper Quality

Bond paper made from at least 80% chemical wood pulp is recommended. Characteristics of this type of paper are normally within the ranges that work best in the continuous forms printer. Experience also indicates that some papers with 25% cotton content are satisfactory. Some recycled papers are satisfactory when the paper parameters meet the recommended values (see “Summary of Paper Selection Recommendations” on page 31).

Some paper suppliers offer recycled and blended papers. Recycled paper should conform to the fiber content characteristics (80% chemically pulped wood), and in all other ways conform to the paper quality recommendations. In addition, recycled paper should be free of any contaminants that may have been added to the paper in its previous application. Some of these contaminants can interfere with print quality, paper handling reliability, or toner adhesion. Additionally, these contaminants can build up on various paper-path and print-element components and cause premature failure of these components. Blended papers of lower chemical wood pulp content may be desirable for economical and ecological reasons. Consider these papers carefully, as there may be an increased printer operating cost when processing these papers.

IBM can assist customers in developing criteria for selecting forms for various applications; however, customers are responsible for initiating contact with form vendors and making the final selection. For additional information, see “Chapter 1. General Guidelines for Selecting Forms” on page 1.

Note: Provide the paper supplier with the form criteria outlined in this guide (see “Summary of Paper Selection Recommendations” on page 31) and request forms that meet these recommendations.

For best performance, use forms that meet the recommendations in this guide. Forms that do not meet these recommendations may be acceptable if they run well

and do not cause machine damage. If the use of a form causes printer damage, service calls, or part replacement (other than that caused from normal wear), IBM will charge the customer for the time and material of all required service and parts.

IBM recommends testing recycled and blended papers for your applications, as described in “Chapter 9. Testing Forms and Applications” on page 47. This testing should consist of an initial test sample (2 to 4 boxes or one third roll) as well as follow-up testing. This follow-up testing should demonstrate the printer’s ability to perform for 30 to 60 days. Perform all initial testing of new forms by using your own application.

Note: Pay special attention to any effect the paper might have on printer components (such as the photoconductor drum and fuser), or on the environment (volatile emissions).

Consider the following paper characteristics when choosing your paper and paper-based forms:

- Paper exposed for about five minutes to a maximum fuser temperature of 204°C (400°F) and a pressure of 50 pounds per square inch (3.4×10^5 N/m²) emits small amounts of some compounds that may cause odors. Examples of odor-causing compounds are sulphur compounds, chlorides, resin-base aerosols, and organics. Such emissions may create an industrial hygiene safety exposure (see “Chapter 10. Safety Practices” on page 53).
- Coated paper and paper with a waxy surface can cause fusing failures.
- Embossed paper may cause wear on printer components, such as photoconductors and fuser rolls, and may reduce print quality.
- Paper containing synthetic resins, synthetic sizing agents, or plastics may cause fusing failures.
- Paper with poor surface stability and high amounts of sizing and filler can create paper dust. Excessive paper dust and chads (the residue separated from the carrier holes) can cause printer malfunctions and operator interventions. Filler should be limited to 15 to 20% by weight.
- Certain adhesives or coatings added to paper can soften or weaken the paper and give off vapors that cause discomfort to operators or service personnel. The additives should not be abrasive or have a tendency to chalk. Test these papers thoroughly before using large quantities.
- Certain salts or metallic compounds added to paper to reduce static charge can reduce print quality and cause printer contamination.
- Fillers and other additives may increase paper abrasiveness and cause excessive machine wear, reduced print quality, increased operator interventions, or fusing failures.
- Some papers produce large amounts of paper dust that can cause reduced print quality, increased operator interventions, and fusing failures. Sizing should hold the filler in the fibers.
- Forms with calender cuts, grease spots, loose sizing particles, wrinkles, voids, cuts, and tears can cause misfeeds and illegible characters.
- Moisture in forms can cause differences in the final print appearance. To transfer enough toner to the paper, the conductivity of the paper must be reasonably low. Increasing paper moisture causes an increase in paper conductivity. The range of 3.7% to 5.3% moisture content, by weight, is best. When testing the moisture content, measure paper immediately after removing it from the shipping carton.

Paper Dust Contamination

Paper dust is loose filler, starch, rosin, and fiber particles. In impact printing processes and nonimpact printing processes, some release of paper dust to the environment and some dust contamination within the printer is unavoidable. Speed and high-volume usage of the continuous forms printer are factors that contribute to the buildup of paper dust on printer components. The level of paper dust due to paper finishing and converting processes influences the need for operator cleanup and printer service. To reduce printer malfunctions and operator interventions, ensure that forms are free of loose or hanging chads (see Table 16 on page 32) and dust.

Using paper with good surface stability and low amounts of internal size and filler reduces contamination from the paper and helps improve fusing quality (see “Fusing Ability” on page 30).

Paper Weight and Thickness

Basis weight refers to the heaviness of paper. The definition of *basis weight* is:

- **In U.S. measurements:** The weight, in pounds, of 500 sheets of 17 inch by 22 inch bond paper. Standard U.S. basis weights are 16 to 42 pounds.
- **In metric measurements:** The weight, in grams, of one sheet of 1 square meter (m^2) paper. Standard metric basis weights are 60 to 160 grams per square meter (g/m^2).

Note: Weight tolerance for continuous forms printers conforms to conventional industry standards ($\pm 5\%$).

Forms with a basis weight of $60 g/m^2$ (16 pounds) or less do not stack or feed as well as heavier forms.

Table 14 gives the recommended basis weights for paper and labels.

Table 14. Basis weight recommendations

Media	Simplex	Duplex
Paper	16 - 42 pounds ^{1 3}	18 - 28 pounds ²
Labels (heaviest part of label)	54 pound	-
Notes:		
1. Duplex printers running in simplex mode should limit weight to 28 pounds on printer 2, and 42 pounds on printer 1.		
2. Exception: 17 pound paper is approved for use in the Japanese markets.		
3. The maximum paper weight for 324 ppm printers running in simplex, duplex, or dual simplex mode is 28 pounds.		

Caliper describes and compares the thickness of paper. The maximum caliper for continuous forms printer forms is 0.0079 in (0.20 mm).

Smoothness

Smoothness is the evenness of the surface of the form. Rough forms tend to cause variable print darkness, loss of fine lines, and poor toner adhesion. Forms that are too smooth may cause jams in the printer. In general, the 3900 family of printers works better with smoother forms than do previous IBM printers.

Form smoothness is a function of:

- The type of material used to make the form
- The processing of the material

For best operation of the continuous forms printer, the smoothness of the form should be between 70 and 150 Sheffield units; (70 to 220 Bendtsen units).

Table 15 provides information on form smoothness. For information specific to 600 pel printers, see Table 12 on page 22.

Table 15. Form Smoothness - continuous forms printers

Type	Recommended Smoothness * (Sheffield Units)	Typical Application
16 pound high-bulk bond paper	200 +	<i>Not Recommended</i>
16 or 18 pound high-bulk bond paper	70 to 200	Internal Reports
20 pound bond paper	70 to 200	Internal reports
20 pound bond paper	70 to 150	Statements/proposals Invoices/bills
20 pound specialty paper	70 to 120	Quality documents

* Smoothness less than 50 Sheffield Units is not recommended for any weight paper that is used on 240/300-pel and 480/600-pel printers.
Note: Test the form selected for each application using the appropriate application before ordering large quantities of the form.

For duplex printing applications, both sides of the paper must fall within the values listed in Table 15.

The family of high-resolution printers will perform better with paper that is smoother than those specified for other continuous forms printers. See your IBM marketing representative for specific paper vendor recommendations to ensure that your high-resolution printer produces the best possible print quality for your application. For additional information, see “Chapter 2. Paper Recommendations for High-Resolution Printers” on page 21.

Fusing Ability

Fusing refers to the process by which toner is melted onto a form to create a permanent bond. Selecting forms designed for electrophotographic printing can enhance fusing quality, and therefore print quality. The information in this section can help you choose paper and paper-based forms that can achieve high-quality fusing. Form testing is always a necessary part of the selection process.

The best fusing is achieved when toner particles adhere to the paper surface, to the individual fibers that make up the paper structure, and to other toner particles.

Depending on the model of the printer, either heat and pressure together, or heat alone is used to fuse the toner with the paper fibers.

The ingredients used in making paper have a significant effect on this process. Some materials resist penetration and adherence of the toner.

The fillers and sizing agents used in paper may vary in different countries, because the raw materials that are available and the cost of those materials vary. Even within a country or geographic area, differences in paper-finishing agents and sizing procedures used by each mill may cause variations in fusing quality. Similarly, papers of different grades from the same mill (for example, bond, uncoated offsets, and ledger) may also have different fusing characteristics.

Good fusing papers contain minimal amounts of the organic additives traditionally used for sizing printing and writing paper (slack rosin-starch sheets). Use paper treated to resist liquid penetration (hard sizing) *only* after thoroughly testing it for fusing quality. The following factors can have a significant effect on fusing quality:

- **Surface Sizing**

Sizing agents affect contact between toner and paper. Avoid paper treated with synthetic sizing agents, such as alkylketene dimer or alkenyl-succinic anhydride. These sizing agents may affect fusing quality. Keep overall sizing low.

- **Smoothness**

In general, the printer's fusing system works better with **smoother** papers. Rough papers tend to reduce fuse quality.

For duplex printing applications, both sides of the paper must fall within the values that are listed in Table 15 on page 30 or Table 12 on page 22.

- **Paper Weight**

Lighter-weight paper improves heat conduction from under the paper to the unfused toner on top of the paper at the preheat platen. See Table 11 on page 18 for recommended paper weights for various sheet lengths.

- **Moisture Content (Shipping)**

Because the printer fusing temperatures can vaporize moisture in the paper, excessive moisture content prevents the paper from heating adequately for fusing. Fusing and paper-handling performance is best with paper that is used immediately after it is removed from the shipping carton. (The moisture content is generally 3.7% to 5.3% when shipped from the paper manufacturer.)

Controlling these characteristics improves fusing performance for many of the papers typically used in the continuous forms printer; however, only actual testing can determine the exact effect of any form on fusing performance.

Summary of Paper Selection Recommendations

Table 16 on page 32 summarizes recommendations that can help you and your paper supplier choose the paper that is *most suitable* for your continuous forms printer. For packaging recommendations, see "Packaging" on page 19.

See "Chapter 7. Selecting Special-Purpose Materials" on page 39 for information and recommendations concerning special paper, such as preprinted, prepunched, and perforated paper.

IBM recommends using 75 g/m² (20 pound) continuous form bond, and that you initially test a small sample of supplies in your continuous forms printer before

you purchase production quantities for a given application.

Table 16. Paper Selection Recommendations - Summary

Parameter	Test Method	Recommendation
Basis Weight (Preferred)	D 464, ISO 536 (see Notes 2 and 3)	20 pound (75 g/m ²)
Acceptable Basis-Weight Range		16–42 pound (60 g/m ² –160 g/m ²) for simplex applications 18–28 pound (68 g/m ² –105 g/m ²) for duplex applications
Caliper	T 411, ISO 534 (see Notes 1 and 3)	0.0032 – 0.0079 in. (0.08 – 0.20 mm)
Stiffness (Taber)	T 489 (see Note 1)	17–19 pound (64–72 g/m ²) Machine direction: 1.2 Taber units Cross direction: 0.5 Taber units
Coefficient of Static Friction	D 1894 (see Notes 2 and 4)	0.45–0.65
Porosity (Gurley)	UM 524, ISO 3687 (see Notes 1 and 3)	10 sec/100 ml minimum
Fiber Composition		80% chemical wood pulp or woodfree pulp (The European term <i>woodfree pulp</i> is synonymous with the American term <i>chemical wood pulp.</i>) (either sulphite or kraft)
Color		White or pastel colors
Ash Content	T 413, ISO 2144 (see Notes 1 and 3)	18% Maximum
Filler		The amount and type of filler should be chosen to produce a paper that has low abrasive and dusting characteristics. In general, low filler percentage and small particle size are best.
Surface Sizing		Starch
Internal Sizing		Acid rosin or synthetic (alkylketene dimer or alkenyl-succinic anhydride)
Moisture Content	D 644, ISO 287 (see Notes 2 and 3)	3.7 – 5.3% (see Note 6)

Table 16. Paper Selection Recommendations - Summary (continued)

Parameter	Test Method	Recommendation
Surface Resistivity	D 257 (see Notes 2 and 5)	$1 \times 10^{10} - 1 \times 10^{12}$ ohms (see Note 6)
Chad		< 25 loose chads per 2500 feet of forms; no hanging chads (all holes fully punched). No agglomerated chads.
Paper Formation	Visual	The paper should be uniform in appearance when it is viewed by holding a light source behind the paper.

All tests were conducted per TAPPI 402 or ISO 187, except moisture content, which pertains to the paper as packaged.

Notes:

1. Testing method—Technical Association of Pulp and Paper Industry (TAPPI).
2. Testing method—American Society for Testing Materials (ASTM).
3. Testing method—International Organization for Standardization (ISO).
4. Use 127 mm per minute (5.0 in. per minute) pull rate.
5. Isolate the test specimen from the metal backing plate with a piece of smooth, nonconductive polyester film, at least 0.254 mm (0.010 in.) thick. Use 100 volts.
6. The following paper parameters have been found to be very important for achieving the best possible print quality on the 600 pel high-resolution printers:
 - Paper formation
 - Uniformity of these properties across the page
 - Electrostatic properties
 - Moisture content
 - Paper smoothness (the 600 pel printers will perform better with smoother paper).

Ask your IBM marketing representative for specific paper vendor recommendations to ensure that your 600 pel printer produces the best possible print quality for your application. For additional information, see “Chapter 2. Paper Recommendations for High-Resolution Printers” on page 21.

7. The maximum paper weight for 324-ppm printers is 28 pounds.

Chapter 6. Selecting Preprinted Forms

This chapter describes important characteristics of inks and papers that you should consider when selecting preprinted forms. A *preprinted* form is one on which ink has been applied before the printer prints on it. This includes mill and converter markings in the carrier strip area.

In some cases, it may be possible to use Advanced Function Printing capabilities instead of preprinted forms. Refer to “Electronic Overlays” on page 37 for information about an alternative to preprinted forms.

General Recommendations

The family of continuous forms printers accept a variety of inks and papers for preprinted forms. When ordering preprinted forms, specify that the forms are intended for use in an IBM continuous forms printer. In addition, the following requirements and recommendations can help you use preprinted forms more effectively and help maintain reliable printer performance:

- The inks and papers that are used in preprinted forms must not emit vapors to the environment at levels that create an industrial hygiene safety exposure.
- Inks with phthalate esters in any concentration should not be used.
- Penetrating inks with high residual amounts of petroleum-based solvents should not be used.
- The inks must not contain any metallic or organic additives that either significantly affect print quality or constitute a health hazard when they are processed by a continuous forms printer (for example, a high titanium content).
- The forms must allow toner to adhere to the paper.
- The forms and preprinted information must not interfere with the normal function of paper path sensors.
- Brightening agents such as titanium should be avoided, especially at high levels to avoid print quality and fusing problems.

Note: To ensure proper printing, two *clear zones* (areas within the tractor-hole strip that contain no printing) are required:

- The first clear zone is 8.13 ± 0.10 mm (0.320 ± 0.004 inches) wide and runs the full length of the form in the process direction. This clear zone is 4.07 ± 0.05 mm (0.160 ± 0.002 inches) on either side of the center line of the tractor holes. Printing in this area causes skew sensor errors and your print job can fail.
- In addition, if side1/side2 verification marks are used, there must be a clear zone that is approximately 51 mm (2 inches) from the top of the form and includes the entire width of the tractor strip.

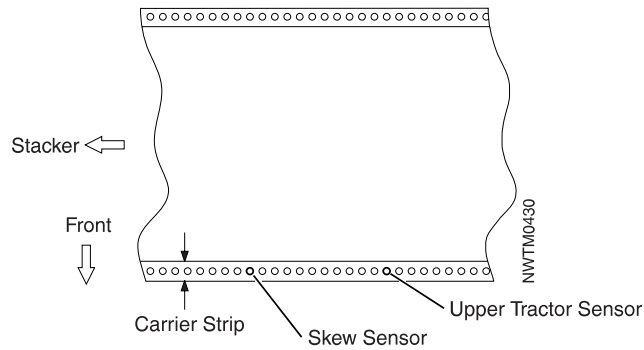

Figure 13. Paper Path Sensor Locations

- The forms must be printed with heat-resistive inks that are formulated to withstand the fusing temperature and the mechanical action of the printer.
- Ultraviolet (UV) inks are recommended for optimum overall performance. UV inks will cure faster and are less likely to transfer to the printer hardware.
- UV inks and soy-based inks should be screened to a level of 50% to reduce the chance of printer contamination.
- After preprinting, allow sufficient time for the ink to cure (dry) before processing the forms. A minimum of 72 hours is recommended. Some inks with different formulations may require additional drying time. If inks are not cured correctly, they will transfer to the components — especially in the fuser area — causing print quality problems, premature parts replacement, and added maintenance.
- The final forms design should be tested on a continuous forms printer to verify that the layout is accurate and that the paper and ink are compatible with the printing process.
- Select paper with pH (hydrogen-ion concentration) for correct ink curing, based on ink and printing conditions.
- Avoid using paper that is smoother than 70 Sheffield Units.
- Avoid preprinted forms that are embossed or thickened.
- If tinting inks are used, enhance fusing quality by screening, or leave the area uninked where the continuous forms printer will print.
- Avoid solid preprinted areas on forms, particularly reverse headings, and logos. To decrease the amount of applied ink, screen the deeper-hued ink to obtain the desired color. These areas can usually be screened to 50% or less without losing their identity.
- Avoid vertical lines. They are more susceptible to ink transfer than horizontal lines. If vertical lines cannot be eliminated, screen them, if possible.
- Store forms within the environmental limits that are described in “Shipping, Storage, and Operating Environment” on page 20 to allow the best drying and curing of the ink. Also, do not use a moisture barrier around cartons during the ink-curing period.

Vapor Emissions from Preprinted Forms

To verify that preprinted forms do not emit unwanted vapors, subject forms samples to a temperature of 204°C (400°F) and a pressure of about $3.4 \times 10^5 \text{ N/m}^2$ (50 psi) for five minutes. Under those conditions the forms must not emit:

- Low-boiling aldehydes or halogen-containing compounds
- Ketones (for example, benzophenone)

- Esters (for example, triacetin)
- Any vapor that causes discomfort to operator or service personnel
- Any vapor that causes printer components to deteriorate.

Electronic Overlays

Advanced Function Presentation (AFP) lets you start with a plain piece of paper and print on it virtually any combination of fonts, lines, and images. AFP also allows you to define and store collections of constant data that can be combined with variable data at print time. This stored constant data is known as an *electronic overlay*. Instead of using preprinted forms, you can use electronic overlays to put boxes, lines, shading, text, and logos on a page.

Using electronic overlays can result in significant savings in forms cost and storage space, as well as in operator time required to load and unload preprinted forms. If a design needs to be changed, electronic overlays can be changed more quickly and without paying scrap charges. In addition, using electronic overlays eliminates concerns about the papers and inks used in preprinted forms.

For additional information about AFP and electronic overlays, refer to *Guide to Advanced Function Presentation*, G544-3876 and *Overlay Generation Language/370: User's Guide and Reference*, S544-3702.

Forms for Advertising

Forms used in advertising often contain special paper and deep-hued, multicolored inks applied in larger amounts than is advisable for use in a continuous forms printer. Sometimes these forms create objectionable emissions and cause ink to transfer to printer components.

Multicolored, heavily inked forms sometimes give off a pungent odor at room temperature. The odor increases when the forms are processed in a continuous forms printer.

Note: Do not use forms that emit vapors that cause discomfort to operators and service personnel.

Improved ventilation can reduce the level of airborne contaminants (see "Chapter 10. Safety Practices" on page 53). Test any applications involving heavily inked preprinted forms before using them for production jobs.

Forms for Negotiable Documents

Special papers and inks are sometimes used for negotiable documents, such as checks, that are intended for use on impact printers. In general, the intent is to improve the anti-fraud characteristics of the documents. Other safeguards, such as unique character sets and type styles, are not often used on impact printers because of increased costs and reduced printer throughput.

With a continuous forms printer, some safety inks and papers tend to inhibit thorough fusing of the toner onto the paper fibers. Uniquely styled characters are easy to develop, and may be an acceptable alternative to special forms.

Note: Test all applications of this type to make sure your output satisfies auditing, security, and environmental requirements.

The following information reflects known practices for negotiable documents or is based on test results.

- In marginal fusing situations, use 75 g/m² (20 pound) paper, which may work better than 90 g/m² (24 pound) paper. Using a different contrast setting on a continuous forms printer can also help.
- Use pre-heat control as instructed in the operator's guide for your printer.
- Change the application program and format to print amounts in both words and numbers, with no loss in throughput. Also, numeric fields can be printed with a reverse character set; that is, the background is toned and the digits are the color of the paper.
- If the document is to be folded, select a lightweight paper that lessens the chance of toner cracking on the fold and breaking characters.
- Use a paper base that fuses well (see "Fusing Ability" on page 30).

Chapter 7. Selecting Special-Purpose Materials

This chapter details recommendations and limitations relating to the following special-purpose materials:

- Prepunched forms
- Labels

“Chapter 9. Testing Forms and Applications” on page 47 contains additional information about techniques to use when you are evaluating special-purpose materials.

Prepunched Forms

The following considerations apply to the location and size of binder holes and corner cuts in forms used with continuous forms printers:

- The total area of binder holes and corner cuts within any 76.2 mm (3 inch) linear segment along the length of the paper web must not exceed 100 mm² (0.16 square inches), regardless of form size.

Note: Forms can have binder holes totaling 100 mm² (0.16 square inches) at both the top and bottom of the form, as shown in Figure 15 on page 40, example A.

- Binder holes and corner cuts (opening containing a right angle) should not be in the 12.7 mm (0.5 inch) tractor-hole margin strips.

Note: An optional hole with a diameter of 4.75 mm (0.187 inch) is allowed at each corner of the form. Figure 15 on page 40, example B, shows permitted combinations of openings per 76.2 linear mm (3 linear inches). Table 17 on page 41 specifies the dimensions of binder holes and corner cuts. Arrangements other than those shown are acceptable when the 76 mm (3 inch) rule is maintained.

- Some binder-hole locations in the interior of the form may contribute to abnormal paper shrinkage at the fuser. When this happens, printing near the hole is fused poorly. As with all forms, you need to test prepunched forms before selecting the final design.
- Binder holes should be at least 6.0 mm (0.24 inch) from horizontal or vertical perforations.

Note: To ensure proper printing, two *clear zones* (areas within the tractor-hole strip that contain no printing) are required:

- The first clear zone is 8.13 ± 0.10 mm (0.320 ± 0.004 inches) wide and runs the full length of the form in the process direction. This clear zone is 4.07 ± 0.05 mm (0.160 ± 0.002 inches) on either side of the center line of the tractor holes. Printing in this area causes skew sensor errors and your print job can fail.
- In addition, if side1/side2 verification marks are used, there must be a clear zone that is approximately 51 mm (2 inches) from the top of the form and includes the entire width of the tractor strip.

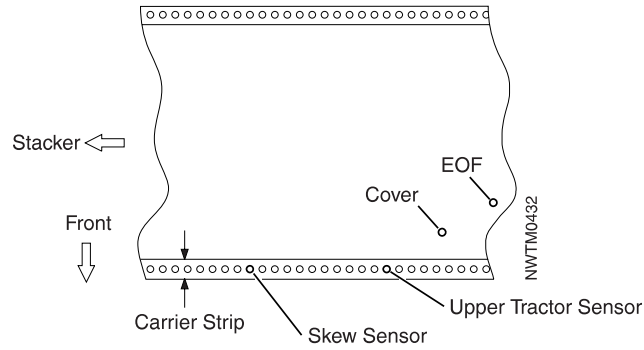

Figure 14. Carrier Strip Sensor Locations

Before making production runs with prepunched forms, test the application to make sure that you are satisfied with the printer performance and the output quality. Prepunched holes can interact with forms line sensors causing misfeeds.

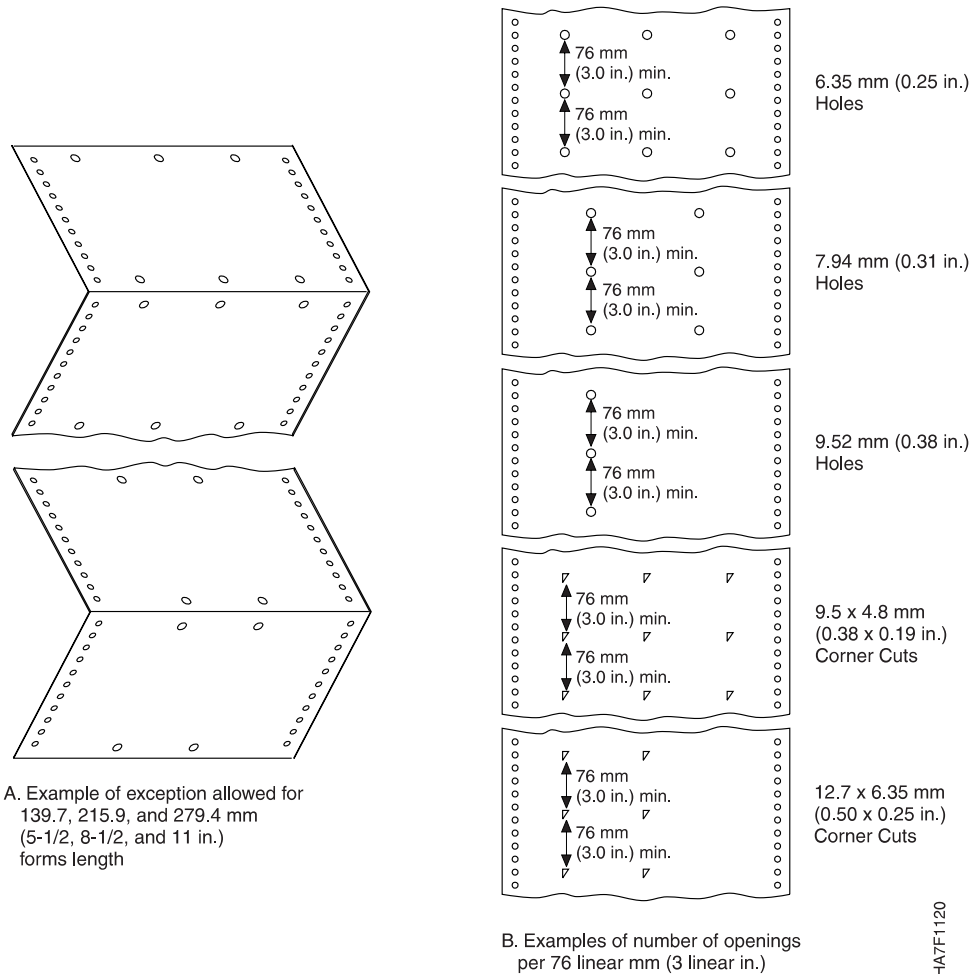

Figure 15. Location and Size of Binder Holes and Corner Cuts. Other sizes of openings and arrangements are acceptable when they do not exceed 96.8 sq. mm per 76 linear mm (0.15 sq. in. per 3 linear in.).

Table 17. Dimensions of Typical Binder Holes and Corner Cuts

Type of Cut	Dimension		Area		Number per 76 linear mm (3 linear inches)
	mm	inch	mm ²	inch	
Binder Hole Diameter	6.35	0.250	31.61	0.049	3
	7.94	0.310	49.68	0.077	2
	9.52	0.38	70.97	0.110	1
Corner Cut, Triangular	9.5 x 4.8	0.380 x 0.190	22.58	0.035	4
	12.7 x 6.35	0.50 x 0.25	40.00	0.620	2

Labels

Printable labels vary widely in their weight, construction, and adhesive. Because of this, **label applications require thorough testing** before ordering production quantities. These applications require more operator support than standard applications.

If you choose to print labels with a continuous forms printer, follow the recommendations in this chapter very carefully and work closely with your IBM marketing representative while you are selecting labels stock. Your marketing representative can give you technical help and share information from other successful continuous forms printer users.

Note: Adhesive labels are not supported for duplex applications. Duplex printing systems can support adhesive labels only when running in simplex mode.

“Chapter 9. Testing Forms and Applications” on page 47 contains additional information about techniques to use when you are evaluating label stock.

Label Design

The final design should be tested on the printers to verify compatibility with the printing process.

Label Types

Figure 16 on page 42 describes the typical types of labels used on continuous forms printers. These labels must meet the requirements set forth in this document.

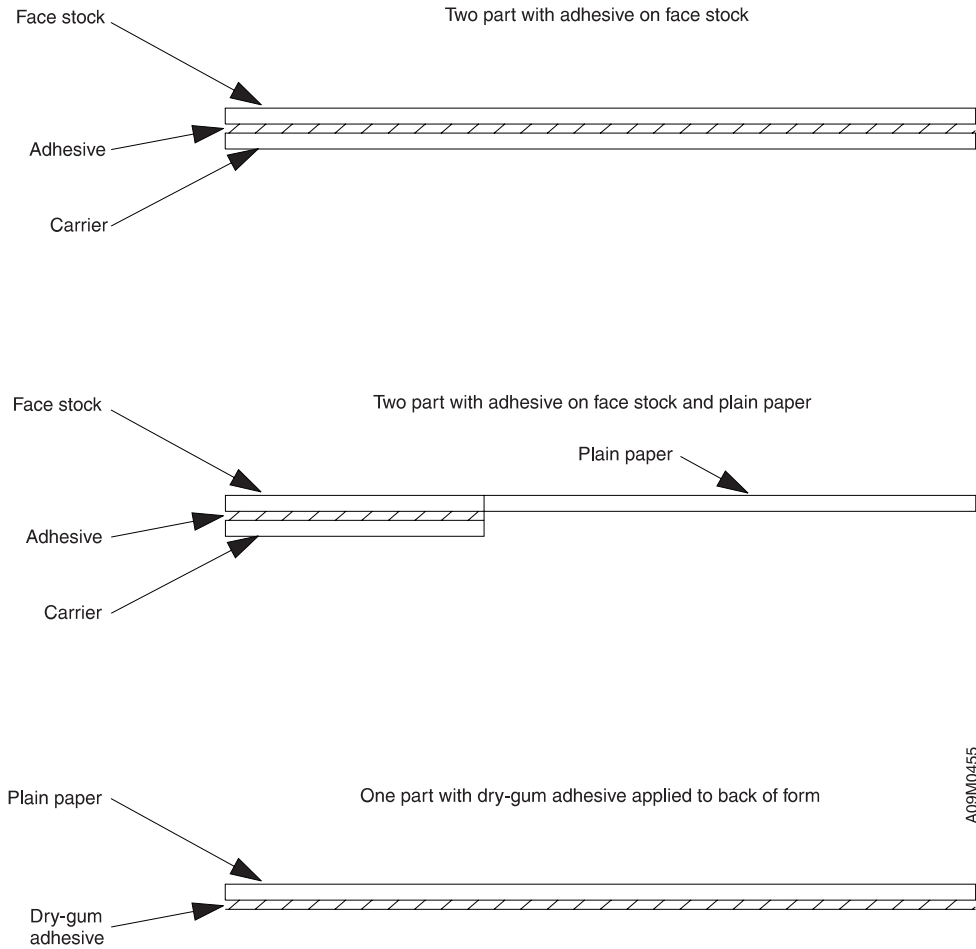

Figure 16. Types of Labels

Label Design Requirements

Labels must withstand a temperature of 204°C (400°F) and $3.4 \times 10^5 \text{ N/m}^2$ (50 psi) while passing through the fuser station. The labels must withstand a continuous temperature of 138°C (280°F) while they sit on the preheat platen when the printer is not printing.

Labels must be placed no closer than 1.27 mm (0.05 in.) to the top or bottom page fold.

The label must be able to form around a 44 mm (1.75 in.) radius at a 180° angle without detacking.

The label must have a minimum release value from the carrier of 40 grams/inch (180° peel at 25 feet/minute).

Adhesive must not be left on the carrier after removing the matrix.

Die cuts and internal perforations must not allow adhesive to ooze to the label surface.

Adhesive

Permanent, removable, or dry-gum adhesive must meet temperature, pressure, and static requirements. The dry-gum adhesives must not abrade (scrape or rub) off the form and deposit on printer components.

Face Stock Selection

The face stock can be paper or other materials. When selecting the face stock, remember the temperatures and pressures previously mentioned.

Because of the low melt point of vinyl materials, their use is not allowed in a continuous forms printer unless they can meet the temperature and pressure requirements.

Face Stock Paper

Paper used in a continuous forms printer must be fanfold (boxed) or roll-feed, continuous-form bond. The accepted definition of bond is paper that is formulated from 80% chemical wood pulp. Characteristics of this type of paper are normally within the ranges that work best in a continuous forms printer. However, experience indicates that papers with 25% cotton content are satisfactory.

Carrier Material

Carrier material must be compatible with the mechanical and thermal conditions present in a continuous forms printer.

Basis Weight and Thickness

The total basis weight for the face stock, adhesive, and carrier must not exceed 25 kg (54 pounds), which equates to approximately 500 sheets of 432 mm x 559 mm (17 in. x 22 in.) paper. The total thickness for the face stock, adhesive, and carrier must not exceed 0.2 mm (.0079 inch).

Smoothness

In order to obtain effective toner transfer and fusing, the Sheffield smoothness must be between 70 and 150 units. For information specific to 600 pel printers, see "Chapter 2. Paper Recommendations for High-Resolution Printers" on page 21.

Recommendations

The following recommendations can help you minimize both printer malfunctions and low-quality results when using a continuous forms printer for printing on pressure-sensitive labels:

- Hold the basis weight and caliper of the label stock to a minimum to decrease the number of machine checks and to improve fusing quality. A continuous forms printer does not accept paper with a caliper greater than 0.2 mm (0.0079 inch) (54 pound stock maximum).
- Label stock must be able to withstand 204°C (400°F) and $3.4 \times 10^5 \text{N/m}^2$ (50 pounds per sq. in.) for about five minutes without functional change, and without causing the adhesive to bleed. Permanent (nonremovable) labels more

often contain adhesives of sufficient heat and pressure stability; therefore, they are likely to perform adequately in a continuous forms printer.

- Label stock must not emit vapors or odors that cause discomfort to operators or service personnel.
- Coated and synthetic labels can cause poor fuse quality and poor operation in the electrophotographic process of the printer. If treatment is necessary, treat labels on the surface only, and use compounds specifically designed to enhance the operation (fusing, for example) of the electrophotographic process.
- If bar codes are used, test them with a scanner to ensure that they meet scanner tolerances for fusing and print quality.
- Page perforations should conform to the tensile strength recommendations in “Perforation Strength” on page 16. Ensure that all perforations are clean and that all pages are lying flat.
- Preprinted label stock should have inks conforming to the recommendations in “General Recommendations” on page 35. Test samples of the stock before ordering large quantities. When running tests, focus on ink stability and the tendency of ink to transfer to printer components.

Operator Tasks

Printing labels sometimes requires operator involvement beyond the usual tasks of loading forms and emptying the stacker. For example, the operator may need to:

- Clean the printer before and after every label job
- Load unusually heavy label stock manually
- Check newly loaded labels for precise alignment and print registration

Refer to your operator’s guide for more information about operator tasks.

Chapter 8. Developing Special Applications

IBM continuous forms printers in combination with IBM's Advanced Function Presentation licensed programs, supports a variety of special applications, such as those that print optical character recognition characters and bar code output. This chapter contains information about the forms used for these applications.

Optical Character Recognition Forms

Special bond and ledger-form papers designed for printing optical character recognition (OCR) are similar to the standard smooth bond described in "Paper Quality" on page 27; however, OCR forms have less contamination and less fluorescence than standard smooth bond, which enhances the OCR reading process. These special papers and similar security papers are not designed for use in the electrophotographic process. **Test them thoroughly before ordering production quantities for your OCR application.**

OCR papers can range from 20 to 24 pound basis weight. However, for best performance, OCR papers should be 24 pound basis weight.

Test OCR applications in the printer for adequate print quality and toner adhesion, and in an OCR reader for character recognition. Refer to "Chapter 9. Testing Forms and Applications" on page 47 for techniques to use when evaluating OCR applications. For further details, consult your IBM marketing representative.

For improved readability, print OCR characters at C1 to C3 contrast settings.

Bar Code Forms

The same paper considerations described for printing OCR forms also apply to printing bar code forms.

Test bar code applications in the printer for adequate print quality and toner adhesion, and in a bar code reader for scanning quality. Test your bar code applications using the techniques described in "Chapter 9. Testing Forms and Applications" on page 47.

The examples in Figure 17 on page 46 show how bar codes can be oriented. Keep these options in mind as you consider label configurations and the type of forms you order for your application.

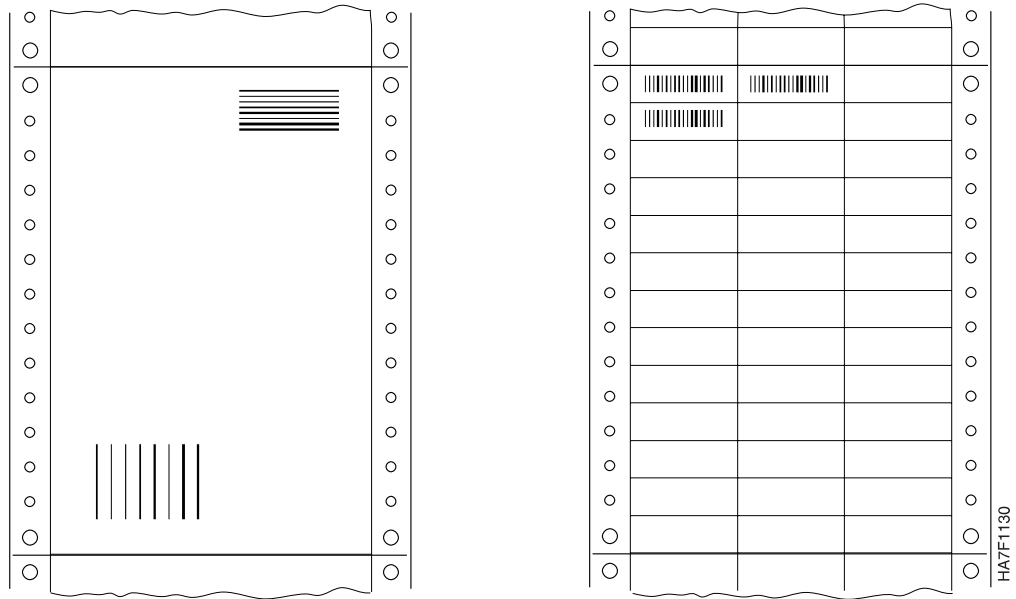

Figure 17. Examples of Bar Code Orientation

Bar codes can be created either by using fonts or by using draw rules. IBM continuous forms printers support the use of the four-pel module width.

The bar code fonts that are available with Bar Codes/Optical Character Recognition, Licensed Program 5688-021, have a minimum-module width of 0.4 mm (0.016 in.). This applies to both bars and spaces. IBM's AFP licensed programs can be used either to modify the module width (for example, to three pels or to six pels) or to control the orientation. For information about the subroutine that accesses and uses these fonts, refer to *Bar Code Fonts User's Guide*, S544-3190. Additionally, information about IBM's AFP licensed programs can be found in *Guide to Advanced Function Presentation*, G544-3876 and *Overlay Generation Language/370: User's Guide and Reference*, S544-3702.

You can create your own bar codes by drawing rules and defining the width of those rules and spaces by using Document Composition Facility (DCF), Licensed Program 5748-XX9, Version 3, Release 2. For more information, refer to *Document Composition Facility: Bar Code User's Guide*, S544-3115.

For information about the advantages and flexibility of bar code printing, refer to *Data Stream and Object Architectures, Bar Code Object Content Architecture Reference*, S544-3766.

Colors

The continuous forms printer processes forms of light-pastel colors such as blue, buff, canary, goldenrod, green, pink, and salmon. All printing by the continuous forms printer is black. Dark paper colors may interfere with operation of the sensor that detects paper jams and the sensors that check for proper steering of forms through the forms path if the colors are in the tractor strip area.

Chapter 9. Testing Forms and Applications

This chapter contains information about testing forms to be used in an IBM continuous forms printer. The chapter answers questions about testing and presents test procedures. The information is intended to help you identify—and avoid—potential forms-related problems. Discovering problems early can save you money in paper and maintenance costs.

Questions and Answers: Testing Forms and Applications

These questions and answers can help you decide what forms and applications to test, and how to test them.

What is an Ideal Form and Application?

An ideal application for a continuous forms printer would print standard-font text and simple images on plain paper. The paper would be 75 g/m² (20 pound) xerographic bond that meets the guidelines found in “Chapter 5. Selecting Paper” on page 27. This paper is manufactured specifically for use in nonimpact printers, and is free of binder holes, cut-outs, and other cuts. The page layout keeps text and images away from perforations. After leaving the printer, output from an ideal application is allowed to cool, and receives minimal handling, rubbing, and creasing.

When processing an ideal form, the printer can deliver optimal print quality and reliability. With forms that deviate from the ideal, print quality may decrease, and the need for operator interventions may increase.

It is important that you test any forms and applications that do not match this ideal form and application description. Do your testing before processing large production orders or print jobs.

When Should I Test My Forms and Applications?

IBM recommends testing all new forms prior to any commitment to purchase large quantities. IBM recommends testing any form that is outside the guidelines specified in “Chapter 5. Selecting Paper” on page 27. This testing will assure that the expected results are achievable. Some candidates for tests:

- Envelopes
- Adhesive labels (simplex only)
- Preprinted forms
- Light or heavy forms
- Rigid forms
- Colored paper
- Recycled paper
- Forms with binder holes, cut-outs, or other cuts
- Forms with running perforations or multiple perforations.

IBM recommends testing all new applications on samples of the expected output forms. Candidates for tests:

- Bar codes
- OCR print
- Solid-fill areas
- Printing near perforations
- Large amounts of text in small fonts
- Images

Sometimes an application is a candidate for testing because of what happens to the output after it leaves the printer. Conditions that can affect print jobs after printing is completed include:

- Heat and Pressure

A continuous forms printer uses heat and pressure or heat alone to put print on the form. Applying heat and pressure to printed output can change the output. For example, if you take forms warm from the printer and put them into a tall stack, the weight of the stack can cause pages to stick together. The same effect can result from using a shearing press to cut stacks of warm forms.

- Moisture

Water and other solvents can cause print to smear on some forms.

- Handling

Frequent handling or rubbing can erase print from a form. For example, print on a price tag may rub off as shoppers repeatedly grasp the tag to look for size and price information. Similarly, perspiration on an operator's hand may leave a blurry thumb print.

What Will Testing Tell Me?

When you test, you can expect one of the following results:

- The application completes successfully, and you are satisfied with the output.
- The application cannot run at all or may require support from the form vendor or IBM Service.
- The application completes, but with some reduction in print quality or printer reliability.

If your application is in the last category, review the output and your requirements, and then decide whether you are satisfied with the quality and reliability achieved. In some cases, you can make changes that improve the test results. Here are some possibilities:

Adjust the Process

Changing any one element in the overall printing process can affect other elements. Review your task from start to finish to determine where adjustments can be made. For example, consider the following:

Can I change the forms?

Can I change the way the forms are stored?

Can I change the application?

Can I change the way the forms are handled after printing?

For example, if you are having trouble with a particular preprinted form, consider whether you can achieve the result you need with an electronic overlay, and eliminate the preprinted form completely.

Consult with your forms suppliers and let them know that you are using a continuous forms printer. They can identify which of their products are suitable for processing on an electrophotographic, hot-fusing printer. Consult your IBM marketing representative for information about forms and applications that are being used successfully with continuous forms printers and other IBM nonimpact printers. Always specify which model of printer that you have when ordering forms from a form vendor.

Adjust the Printer

IBM printers have print quality controls that are accessible to the operator. Refer to the Operator's Guide for your printer for information on how to improve print quality.

If print quality problems persist, call your service representative to verify that the printer is adjusted to specification.

How Do I Evaluate the Test Results?

The tests described raise some important questions. Only you and your user community can determine which questions are most important, and what levels of quality and reliability are acceptable in your particular circumstances.

The most important result of form testing is *knowledge*. A well-designed test lets you know what kind of print quality and reliability you can expect. Based on this knowledge, you can make informed decisions and trade-offs in choosing forms and applications for use with your continuous forms printer.

What Kind of Testing Should I Do?

Because every installation's needs and processing environment are unique, no two test plans are identical; however, there are some general guidelines to follow.

Whenever possible, run the following three tests for each form and application combination:

- Single-lot multiple box or roll test
- Multiple-lot test
- Sample production run

Ideally, run these tests in your processing environment using your actual application.

Single-Lot Multiple Box/Roll Test

The single-lot multiple box or roll test consists of printing an entire box of forms or enough of a roll of a particular form to simulate an entire box. Consider the following questions while the printer is running:

- Do forms feed smoothly from the input area?
- Do you detect any odors that could indicate possible health and safety hazards resulting from heating the forms?

- Does the printer issue machine checks or other messages requiring operator intervention?
- Does the application process smoothly, without pauses or jerky motions?
- Do the forms generate noticeable paper dust, chads, or other debris?
- Do the pre-/post-processing devices handle the forms?
- Is the form side sensitive for duplex?
- Do adhesive labels peel off their carrier?
- Does any glue seep out from under adhesive labels during printing and contaminate the drum, hot roll, or other parts of the printer?
- Do the forms fold and stack correctly?
- Do the forms provide the desired print quality?

After the entire box or roll is used, inspect the printer and consider the following questions:

- Did paper dust, chads, loose labels, or other debris accumulate in the printer during processing?
- Are there adhesive, ink, or toner deposits on the printer rollers?

Inspect the printed output and consider the following questions:

- Is the printing crisp and clear, especially close to edges, perforations, holes, and cuts?
- Is print quality uniform across the page and throughout the box or roll?
- Can OCR and bar code output be read correctly by the scanners for which they are intended?
- Are solid-fill areas printed evenly?
- Does toner leave ghost images on facing pages?
- Do the forms show any discoloration after processing?
- Do colored inks on preprinted forms change color?
- Do the forms shrink or change shape during processing?
- Do the forms get wrinkled during processing?

Multiple-Lot Test

The multiple-lot test helps you determine whether a manufacturer's forms are uniform across different lots. To perform the multiple-lot test, take samples from several boxes or rolls of the same type of form. Print identical output on each of these samples, and compare the quality. Are the results uniform?

Sample Production Run

Running a full-scale production job, including all pre- and post-processing, can reveal potential trouble spots that were not evident in the shorter tests. When you evaluate the sample production run, use the procedure described in "Single-Lot Multiple Box/Roll Test" on page 49. Be sure to monitor the entire printing process, and examine samples from the beginning, middle, and end of the job.

Consider the following questions as you handle the forms *as they will be handled after production processing*:

- Does the print smear?
- Does the print rub off or erase easily?
- Do the forms stick together after they have been refolded and allowed to cool?

If any of these problems occur, review the suggestions given in “Adjust the Process” on page 48.

Troubleshooting

This section identifies situations that can cause problems during printer processing. Consider these possibilities when you attempt to resolve print quality or reliability problems during testing.

Printing on the Reverse Side

Occasionally, paper printed on one side is recycled by printing it on the reverse side. Paper printed by a printer that uses the electrophotographic process should never be rerun on a continuous forms printer. Heat from the fuser softens the original toner and contaminates printer components. The result is lower print quality and possibly more paper jams.

Note: In duplex printing applications the second printer fuses at a lower heat to prevent any print quality problems.

Printing on the reverse side is allowable only on Printer 2 of a duplex printing system. The original print on the front side must be printed by Printer 1 of the duplex system.

Chapter 10. Safety Practices

When selecting ink and paper, consider that fusing temperatures and mechanical actions may cause vapors to be emitted at levels that create an industrial hygiene safety exposure. This chapter describes health and safety considerations for a variety of paper and preprinted forms used with the an IBM continuous forms printer.

Blank Forms

Paper exposed for about one second to a maximum temperature of 204°C (400°F) and a pressure of 3.4×10^5 N/m² (50 psi) emits small amounts of some compounds (such as sulphur compounds, chlorides, resin-base aerosols, and organics), which may cause odors. Some of these compounds can cause eye or throat irritation, or other physical discomforts, to printer operators and service personnel. Aerosols may also cause parts of the printer to deteriorate.

Preprinted Forms

In addition to the safety considerations for paper in forms as described above, observe the following for ink when using preprinted forms:

- Reduce the use of preprinted solid areas on forms, particularly reverse headings and logos.
- Allow the ink on preprinted forms to cure completely before processing the forms through a continuous forms printer. A minimum of 72 hours of curing time is recommended. This will allow most volatile materials to evaporate prior to processing.
- Provide adequate ventilation around the printer to reduce the exposures associated with heavily inked preprinted forms.

Adequate venting and filtering are essential to lower the level of airborne contaminants and to help provide a satisfactory printer environment. Follow the ventilation guidelines provided by IBM in the *IBM System/360, System/370, 4300, and 9370 Processors Input/Output Equipment Installation Manual—Physical Planning*, GC22-7064.

To ensure health and safety, the American Society of Heating, Refrigeration, and Air Conditioning Engineers (ASHRAE) recommends in ASHRAE 62-1989 that the air makeup in the computer room contain at least 20 cubic feet per minute of outdoor air for each person.

- Avoid using forms with ink manufactured using iodine as a catalyst or stabilizer. Inks should not emit vapors at levels that cause an industrial hygiene safety exposure (see “Vapor Emissions from Preprinted Forms” on page 36 for details).
- Keep covers closed when the printer is operating.

Electronic Overlays

Using electronic overlays can prevent the possible hazards involved with preprinted forms. Advanced Function Presentation (AFP) lets you start with a plain piece of paper and print virtually any combination of fonts, lines, and images. AFP also allows you to define and store collections of constant data that

can be combined with variable data at print time. This stored constant data is known as an *electronic overlay*. Instead of using preprinted forms, you can use electronic overlays to put boxes, lines, shading, text, and logos on a page.

Using electronic overlays can result in significant savings in forms cost and storage space, as well as operator time required to load and unload preprinted forms. If a design needs to be changed, electronic overlays can be changed more quickly and without paying scrap charges. In addition, using electronic overlays eliminates concerns about the papers and inks used in preprinted forms.

For additional information about AFP and electronic overlays, refer to *Guide to Advanced Function Presentation*, G544-3876 and *Overlay Generation Language/370: User's Guide and Reference*, S544-3702.

Labels

In addition to the safety considerations for paper and ink as described above, observe the following recommendations when using labels:

- Provide adequate ventilation around the printer to reduce the exposure associated with vapors created when the adhesive and carrier are heated in the fuser.

Adequate venting and filtering are essential to lower the level of airborne contaminants and to help provide a satisfactory printer environment. Follow the ventilation guidelines provided by IBM in the *IBM System/360, System/370, 4300, and 9370 Processors Input/Output Equipment Installation Manual—Physical Planning*, GC22-7064.

To ensure health and safety, the American Society of Heating, Refrigeration, and Air Conditioning Engineers (ASHRAE) recommends in ASHRAE 62-1989 that the air makeup in the computer room contain at least 20 cubic feet per minute of outdoor air for each person.

- Handle labels carefully immediately after printing. They are hotter than paper because the heavier mass of paper, adhesive, and carrier of the label retains more heat than paper alone.

Multipart Carbonless Paper

IBM does not recommend the use of multipart carbonless papers with continuous forms printers.

Acronyms and Abbreviations

This list explains the acronyms and abbreviations used in the continuous forms printer documentation library.

AFP Advanced function printing.

AFPDS Advanced function printing data stream.

APA All-points addressable.

ASTM American Society for Testing Materials

CCW Channel command word.

CE Customer Engineer (IBM).

CSW Channel status word.

DASD Direct-access storage device.

DCF Document Composition Facility.

EBCDIC Extended binary-coded decimal interchange code.

EC Engineering change.

FLSF Font Library Service Facility.

FORMDEF Form definition.

GDDM Graphical Data Display Manager.

IML Initial microcode load.

IPDS Intelligent printer data stream.

ISO International Organization for Standardization.

JES2 Job entry system 2.

JES3 Job entry system 3.

KB Kilobyte (1KB=1 024 bytes).

MB Megabyte (1MB=1 048 576 bytes).

MVS Multiple virtual storage.

MICR Magnetic ink character recognition.

MVS/SP Multiple Virtual Storage/System Product.

NPRO Nonprocess runout.

OCR Optical character recognition.

OGL Overlay Generation Language.

OS/VS Operating System/Virtual Storage.

PAGEDEF Page definition.

PC Photoconductor.

PEM Print-error marker.

PMF Print Management Facility.

PPFA Page Printer Formatting Aid.

PSAF Print Services Access Facility.

PSF Print Services Facility.

RAM Random access memory.

SCSW Subchannel status word.

SDLC Synchronous Data Link Control.

TAPPI Technical Association of Pulp and Paper Industry

TCS Two-Channel Switch.

VSE Virtual Storage Extended.

VSE/AF Virtual Storage Extended/Advanced Functions.

VSE/SP Virtual Storage Extended System Package.

Glossary

The following terms are defined as they are used in continuous forms printer documentation. If you do not find the term you need, refer to the index or to the *IBM Dictionary of Computing*, SC20-1699.

A

adhesive label. Special-application material; typically consists of paper labels coated on one side with an adhesive mixture, temporarily affixed to backing material. See also *carrier*.

all-points addressability. The capability to address, reference, and position text, overlays, and images at any defined point on the printable area of a page.

application. The use to which an information processing system is put; for example, a payroll application, an airline reservation application, a network application.

application program. A program written for or by a user that applies to the user's work, such as a program that does inventory control or payroll.

application programmer. One who develops application programs. Contrast with *system programmer*.

B

bar code. A code representing characters by sets of parallel bars of varying thickness and separation that are read optically by transverse scanning.

basis weight. The weight in g/m² or pounds of a ream (500 sheets) of paper cut to a given standard size for that grade. The basis weight of continuous form for computer output is based on the size for bond papers.

binder holes. A series of holes or slots punched at set intervals that allows the form to be inserted in a loose-leaf or ring binder.

bond (paper). Paper formulated with at least 80% wood pulp. Bond-paper forms work best in the IBM continuous forms printer.

C

calender. A process to make paper smooth or glossy by passing it through a series of metal rollers during the last steps of a paper-making machine.

calender cut. Slits, glazed lines, or discolored lines across the paper caused when wrinkles pass through the calender rollers.

caliper. The thickness of forms, usually expressed in tenths of a mm or thousandths of an inch.

carrier. The backing material for labels. Labels consist of the printable material, the adhesive, and the carrier.

chad. (1) The material separated from a data medium when punching a hole. (2) The residue separated from the carrier holes in continuous form.

change. As used in continuous forms printer action messages, instructs the printer operator to remove and discard a used component and then install a new one. For example, the CHANGE TONER COLLECTOR message means that the operator should take out the toner-collector bottle, throw it away, and put in a new one.

channel command. An instruction directing a data channel, control unit, or device to perform an operation or set of operations.

character. A letter, number, punctuation mark, or special graphic used for the production of text.

character set. (1) A finite set of different characters that is complete for a given purpose; for example, the character set in ISO Standard 646, "7-bit Coded Character Set of Information Processing Interchange." (2) A group of characters used for a specific reason; for example, the set of characters a printer can print.

check. As used in continuous forms printer action messages, instructs the printer operator to inspect a component. For example, the CHECK TONER COLLECTOR message means that the operator should look at the toner-collector bottle and make sure that it is physically present, in the proper place, and correctly installed.

clear. As used in continuous forms printer action messages, instructs the printer operator to remove crumpled forms, paper scraps, and other debris from the printer. For example, the CLEAR UPPER TRACTOR message means that forms have gotten wedged in the transfer station area, and the operator must remove them before the printer can operate.

coated paper. Paper that has had a surface coating applied to produce smoothness.

configuration. (1) The arrangement of a computer system or network as defined by the nature, the number, and the chief characteristics of its functional units. More specifically, the term configuration may refer to a hardware configuration or a software configuration. (2) The devices and programs that make up a system, subsystem, or network.

configure. The procedure used to customize the continuous forms printer to a specific operating and communication environment.

connector. A means of establishing electrical flow.

constant data. Data that does not change; for example, the company letterhead and standard text in form letters, or the headings and boxes on a preprinted form. Contrast with *variable data*.

continuous forms. A series of connected forms that feed continuously through a printing device. The connection between the forms is perforated to allow the user to tear them apart.

controlled-access area. An area where access is limited to authorized personnel.

controlling computer. The processing unit to which the continuous forms printer is attached through a channel interface.

controlling computer system. The data processing system to which a network is connected and with which the system can communicate.

corner cut. In a form, a cut or opening of any size containing one or more right angles.

corona. A small diameter wire (or wires, depending on the function) to which a high voltage is applied, causing ionization of the air. The ionization creates an electrical charge to perform various functions during the printing process.

cure. The process of drying ink sufficiently for minimum transfer of the ink to any parts of the printer it contacts.

cut. The severed part of a perforation. Cuts are separated by ties. See also *perforation*.

cutout. A part of the form that either has been eliminated or perforated for subsequent removal; for example, corner cuts and binder holes.

D

data streaming. A non-interlocked method of data transfer used by the printer channel to decrease data transfer time during write operations.

developed image. The image that has been exposed onto the photoconductor and covered with toner by the developer.

developer mix. A combination of carrier beads and toner in which the beads electrically charge the toner.

diagnostic. Pertaining to the detection and isolation of errors in programs and faults in equipment.

diagnostic mode. The operational mode in which the printer can check itself in case of a malfunction. When the continuous forms printer is in diagnostic mode, it is not accepting information from the attached controlling computer system. In the continuous forms printer, only service representatives can use diagnostic mode. Contrast with *print mode* and *test mode*.

dishing. The curve a stack of forms takes when folded or refolded at the fold perforation.

diskette. A thin, flexible, magnetic disk enclosed in a protective jacket.

Document Composition Facility (DCF). An IBM licensed program that provides text formatting for the continuous forms printer.

down fold. Fanfold forms are alternately folded. When fanfold forms are unfolded and held horizontally, a fold is a down fold if it points down from the horizontal surface.

drag. The resistance to forms feeding freely into the printer; for example, the form rubbing against the carton.

E

electronic overlay. A collection of constant data electronically composed in the controlling computer. Can be merged with variable data on a page during printing. An electronic overlay defines its own environment. It can be in coded form or raster pattern form. Contrast with *page segment*. See also *forms overlay* and *preprinted form*.

electrophotographic process. The creation of an image on forms by uniformly charging the photoconductor, creating an electrostatic image on the photoconductor, attracting negatively charged toner to the discharged areas of the photoconductor, and transferring and fusing the toner to forms.

emboss. To press and raise the surface of paper into a design. Embossed paper appears thicker than nonembossed paper, can increase printer wear, and can degrade print quality.

end-of-forms sensor. A sensor that detects when the last sheet of a form enters the printer.

error log. (1) A data set or file in a product or system where error information is stored for later access. (2) A record of machine checks, device errors, and volume statistical data.

F

face stock. The printable surface of a label.

fanfold. Continuous forms that are alternately folded at regular intervals, usually on a perforation.

fold memory. The ability of a form to refold at the fold perforation after exposure to heat during the fusing process.

fold perforation. The perforation on which a form is folded during manufacture and refolded after printing. See also *page perforation*.

Font Library Service Facility (FLSF). A licensed program that provides a way to make changes to a font while retaining its format, as defined by the architecture and as required by Print Services Facility.

forms. The material on which output data is printed, such as paper or adhesive labels. The area between perforations on continuous printer forms. See *electronic overlay* and *preprinted form*.

forms path. The entire route that forms travel during processing. The forms path usually begins where the forms are loaded and ends at the stacker. Synonym for *paper path*.

format. (1) The arrangement or layout of data on a data medium. (2) The size, style, type of page, margins, printing requirements, and so on, of a printed page.

form definition (FORMDEF). A statement that specifies the attributes of a physical page, such as the number of copies and one-sided or two-sided printing.

fuse. To use heat and pressure to blend toner onto forms to make a permanent bond.

G

graphic. A symbol produced by a process such as handwriting, drawing, or printing.

Graphical Data Display Manager (GDDM). An IBM licensed program that allows pictures to be defined and displayed through function routines.

I

IBM branch office. The local IBM sales office.

IBM Customer Engineer. An IBM representative who services IBM products in the field.

IBM Installation Planning Representative. An IBM representative who assists customers in planning and meeting the requirements for installing hardware.

IBM marketing representative. An IBM representative who takes product orders.

IBM World Trade Corporation. A subsidiary of IBM that manufactures and markets IBM products outside of the United States.

impact printer. A printer in which printing is the result of mechanical impacts. Contrast with *nonimpact printer*.

installation. (1) In system development, preparing and placing a functional unit in position for use. (2) A particular computing system, including the work it does and the people who manage it, operate it, apply it to problems, service it, and use the results it produces.

installation verification procedure. A procedure distributed with IBM licensed programs that tests the newly installed IBM programs to verify that the basic facilities of the programs are functioning correctly.

Intelligent Printer Data Stream (IPDS). Information the system sends to printers that contain decision-making capability. Generally, this information contains basic formatting, error recovery, and character data.

ISO sizes. Pertaining to a set of paper sizes selected from those standardized by the International Organization for Standardization (ISO) for use in data processing.

J

jam. In a printer, a condition where forms have become blocked or wedged in the forms path such that the printer cannot operate.

JES2. An MVS subsystem that receives jobs into the system, converts them to internal format, selects them for running, processes their output, and purges them from the system. In an installation with more than one processor, each JES2 processor independently controls its job input, scheduling, and output processing. See also *JES3*.

JES3. An MVS subsystem that receives jobs into the system, converts them to internal format, selects them for running, processes their output, and purges them from the system. In complexes that have several loosely coupled processing units, the JES3 program manages processors so that the global processor exercises centralized control over the local processors and distributes jobs to them via a common job queue. See also *JES2*.

L

landscape orientation. Text and images that are printed parallel to the longer side of the forms. Contrast with *portrait orientation*.

laser (light amplification by stimulated emission of radiation). A device that emits a beam of coherent light.

latent image. In a printer, the invisible image that exists in the sensitized material after exposure but before development.

layout plan. A list of requirements, such as electrical and space, that must be considered before installing an IBM continuous forms printer.

library. A collection of related files. For example, one line of an invoice may form an item, a complete invoice may form a file and the collection of inventory control files may form a library. The libraries used by an organization are known as the data bank.

licensed program. A separately priced program that bears an IBM copyright and is offered to customers under the terms and conditions of the Agreement for IBM Licensed Programs.

line printer. A printer that prints a line of characters as a unit. Contrast with *page printer*.

logical page. The print on the page, such as composed text, graphics, and fonts within defined margins. Contrast with *physical page*.

logo. An identifying emblem, statement, or motto of a company.

M

microcode. In the continuous forms printer, refers to the microprogramming stored on the microcode (or EC) diskette. Microcode is used by the control unit to manage the printer and its functions.

microperforation. Extremely small perforations. After forms are separated, those with microperforations typically have smoother edges than those with regular perforations.

Multiple Virtual Storage/System Product (MVS/SP). Consisting of MVS/System Product Version 1 and the MVS/370 Data Facility Product operating on a System/370 processor.

N

nonimpact printer. A printer in which printing is not the result of mechanical impacts.

nonprocess runout (NPRO). An operation that moves forms through the forms path without printing new pages.

O

offset paper. A grade of paper to which sizing is added to resist moisture. This paper is also treated on the surface to prevent lifting of the paper surface during printing by ink presses.

operating environment. The physical environment; for example, temperature, humidity, layout, or power requirements.

operating requirements. A list of requirements, such as environmental, electrical, and space, that must be satisfied before the IBM family of continuous forms printers are installed.

Operating System/Virtual Storage (OS/VS). A compatible extension of the IBM System/360 Operating System that supports hardware and the extended control facilities of System/370.

optical character recognition (OCR). Character recognition that uses optical means to identify graphic characters.

orientation. The number of degrees an object is rotated relative to a reference; for example, the orientation of an overlay relative to the page point of origin. See also *text orientation*.

overlay. See *electronic overlay*.

Overlay Generation Language (OGL). The licensed program that is used to create electronic overlays.

P

page. A printed form. See also *logical page* and *physical page*.

page definition (PAGEDEF). A statement that specifies attributes of a logical page, such as the width of its margins and the orientation of text.

page perforation. The perforation that defines the page of a form. It may or may not be at a fold in the form. A form may have several pages between each fold. See also *fold perforation*.

page printer. A device that prints one page as a unit. Contrast with *line printer*.

Page Printer Formatting Aid (PPFA). A licensed program that creates form definitions (FORMDEFs) and page definitions (PAGEDEFs).

pallet. A portable platform for handling, storing, or moving materials.

paper break. A separation, either at a perforation or from a tear, of the continuous form paper.

paper path. The entire route that forms travel while they are being processed. The paper path usually begins where the forms are loaded and ends at the stacker. Because not all forms are paper, the term *forms path* is preferred.

parameter. A variable that is given a constant value for a specified application and that may denote the application.

PC drum. Photoconductor drum. A hollow cylinder that is covered with photoconductive material.

pel (picture element). (1) An element of a raster pattern; a point where a toned area on the photoconductor may appear. (2) On an all-points-addressable output medium, each pel is an addressable unit. On a row-column addressable output medium, the only pel addressable is the beginning of a character cell.

perforation. A linear series of unconnected cuts in the continuous form paper. The interval between cuts is referred to as a tie. The perforation defines either a fold or page boundary. See also *cut*, *fold perforation*, *microperforation*, and *page perforation*.

photoconductor. The material that is wrapped around the drum. The medium for transferring images to paper.

physical page. The form on which the printer is printing, such as an 8.5 x 11-inch sheet of paper.

physical planner. The person in an organization who plans the environmental, electrical, and space requirements for your facility.

planning coordinator. The person in your organization who is responsible for coordinating all the planning and installation activities for the continuous forms printer.

plant. A manufacturing location.

point of origin. The location of the first print position on a logical page. The point of origin is usually stated in terms of X and Y coordinates. The point of origin used by a printer can be affected by factors such as printable area and form orientation.

portrait orientation. Pertaining to a display or hard copy with greater height than width. Contrast with *landscape orientation*.

preprinted form. A sheet of forms containing a preprinted design of constant data with which variable data can be combined. See also *electronic overlay*.

Print Management Facility (PMF). An interactive menu-driven program that can be used to create and modify fonts and to define output formatting for data printed on the IBM family of continuous forms printers.

print mode. The operational mode in which information is received from the attached controlling computer system and printed output is produced. Contrast with *test mode* and *diagnostic mode*.

print position. The physical positions of the characters constituting a print line relative to the form.

print quality. The quality of printed output relative to existing standards and in comparison with jobs printed earlier.

Print Services Access Facility (PSAF). A menu-driven, print parameter selection program for page printers controlled by PSF.

Print Services Facility (PSF). An IBM program that provides device support for advanced function printing.

print surface. The side of a form that receives the printed image.

R

raster. (1) In computer graphics, a predetermined pattern of lines that provides uniform coverage of a display space. (2) The coordinate grid that divides the display area of a display device. (3) In the printer, an on/off pattern of electrostatic images produced by the laser print head under control of the character generator.

raster pattern. A series of picture elements (pels) arranged in scan lines to form an image.

registration. In printing, refers to the relative print positions of images that are printed at different times. For example, when you process preprinted forms, the registration is good if the new image printed by the continuous forms printer aligns correctly with the preprinted image. Print that extends beyond box edges and text that overlaps other text are examples of poor registration.

resistivity. An electrical characteristic of paper that is a measure of its ability to resist an electrical charge.

resource. (1) People, equipment, or material used to perform a task or a project. (2) Any facility of a computing system or operating system required by a job or task, including main storage, input/output devices, processing units, data sets, and controller processing programs; for example, page printers use resources such as form definitions, page definitions, and fonts.

reverse heading. A heading where each character is highlighted by reversing the color of the character with its background; for example, changing a black character on a white background to a white character on a black background.

running perforation. A perforation that is vertical and next to the tractor holes.

S

scanner. A device that examines OCR, MICR, or bar code patterns and generates electrical signals corresponding to the pattern. It sends the signals to a computing device for processing.

screen or screening. In document printing, a sheet of material, usually film, carrying a regular pattern of small dots. When printing, ink adheres only to the dots, and many dots close together appear solid. This method prints large areas of ink on paper but uses much less ink than printing the same area with solid ink.

security paper. Specially formulated paper used for negotiable documents, such as checks. Security paper improves the anti-fraud characteristics of the document.

shift. A scheduled work period. For example, a 24-hour day is often divided into three 8-hour shifts.

sizing. A process where paper is treated to give it resistance against penetration of liquids.

smoothness. Having a continuous even surface.

special-purpose materials. Printable items other than blank forms; for example, adhesive labels and preprinted forms.

stack lean. A measurable slope from the vertical of a stack of forms. Excessive stack lean can cause failures when feeding and refolding forms.

Synchronous Data Link Control (SDLC). A standardized discipline used for managing synchronous, code-transparent, serial-by-bit, information transfer over a link connection.

system reference code. A code that contains information, such as a failing field-replaceable unit, for a customer engineer.

system programmer. A programmer who plans, generates, maintains extends, and controls the use of an operating system, with the aim of improving overall productivity of an installation.

System/370. An upward-compatible extension of the IBM System/360. A large collection of computing system devices that can be combined to produce a wide range of computing systems that share many characteristics, including a common machine language.

T

task. A basic unit of work to be accomplished by a device or an operator.

tensile strength. A measure of the force that the paper forms can withstand without tearing.

test mode. The operational mode in which the printer can produce print samples, accept configuration changes, and control traces. When the continuous forms printer is in test mode, it is not accepting information from the attached controlling computer system. Contrast with *print mode* and *diagnostic mode*.

text orientation. The position of text as a combination of print direction and baseline direction.

tie. The interval between cuts of a perforation. See also *perforation*.

toner. The material that forms the image on the paper.

trace. (1) A record of the running of a computer program. It exhibits the sequences in which the instructions were executed. (2) To record a series of events as they occur. (3) In the continuous forms printer, a customer engineer and customer analysis procedure.

tractor. The mechanism that controls movement of continuous form by way of holes (see *tractor holes*).

tractor holes. The holes in the side margins on continuous form. When placed on the tractor pins, the holes maintain printer alignment and registration, and control the movement of the paper.

Two-Channel Switch. A hardware feature that allows an input or output device to be attached to two channels.

U

up fold. Fanfold forms are alternately folded. When fanfold forms are unfolded and held horizontally, a fold is an up fold if it points up from the horizontal surface.

V

variable data. The data that can vary; for example, the names and addresses in form letters. Contrast with *constant data*.

Virtual Storage Extended (VSE). An operating system that is an extension of Disk Operating System/Virtual Storage.

virtual storage extended/advanced functions (VSE/AF). The minimum operating system support for a VSE-controlled installation.

void. (1) A missing part of the printed character. (2) A missing piece of a continuous form.

W

web. A roll of forms.

Index

Numerics

600 pel printers, paper recommendations 21

A

abbreviations 55
acronyms 55
advanced function printing 37, 53
AFP 37, 53
applications
 bar code 48
 OCR 48
 testing 47, 48, 49
ash content, forms 31
ASHRAE 53, 54
ASTM test reference 19

B

bar codes
 forms 45
 orientation (labels) 45
 testing 48
basis weight, paper
 basis weight 31
 how determined 29
 metric measure 29
 tolerance 29
 U.S. measure 29
binder holes
 dimensions of 41
 examples of 41
 location 39
 restrictions 39
 size 39
blended, paper 27
bond (paper) 27
bond paper, smoothness 30

C

calender cut, causing misfeeds 28
caliper 29, 31
character
 avoiding illegible 28
coated paper, effects of using 28
color 31
composition, fiber 31
continuous form paper
 sizes of tractor holes 7
corner cut
 location and size 39
cure (ink)
 allowing time 36
cutouts
 dimensions of 41
 examples of 41
 location 39
 restrictions 39

cutouts (*continued*)
 size 39
cuts (in perforations)
 cuts and ties, ratio 16
 effect on perforation strength 16
 embossing 16

D

dimensional characteristics
 page uniformity 6
 stack lean 8
direct mail advertising 37
dishing
 limits 10
documents
 bar codes 45
 checks 37
 marginal fusing of toner 38
 OCR 45
 safeguards 37
drag, paper
 avoiding 19

E

edge accuracy 12
electronic overlays 37, 53
electrophotographic
 paper not designed for 45
 using coated and synthetic labels 44
 using special papers in 45
emboss (paper)
 effects of using 28
 perforations 18
 why to avoid them 36
end-of-forms sensor
 interference with 19
environment
 operating 20
 shipping 20
 storage 20
evaluating test results 49

F

fanfold 1
fiber composition 31
filler 31
fold 1
forms
 applications testing 47
 basis weight 29
 colors 46
 dimensional
 characteristics 6
 page uniformity 6
 stack lean 8
 electronic 37, 53
 fusing considerations 29
 InfoPrint 3000 25

forms (*continued*)
 InfoPrint 62 23
 operating environment 20
 packaging 19
 page uniformity 6
 paper, sizes 29
 paper, weight 29
 prepunched 39
 safety practices 53
 safety practices for preprinted forms 53
 shipping environment 20
 sizes 2
 smoothness 29
 stack lean 8
 stacking reliability 29
 standards 6
 storage environment 20
 terminology 1
 testing 47, 49
 weight 29
forms, preprinted, selecting 35
friction, static 31
fuse
 improperly-cured inks, effects on
 continuous forms printer 36
 near cutouts, holes 39
 temperature 28
fusing ability
 moisture content 30
 paper weight 30
 sizing 30
 smoothness 30

G

gauge
 stack lean 9
general guidelines for selecting forms 1
glossary 57
gurley 31

H

high-bulk bond, smoothness 30

I

image areas 4
InfoPrint 3000, forms specifications 25
InfoPrint 62, forms specifications 23
ink
 bar code documents 45
 OCR documents 45
ink recommendations
 bar code documents 45
 IBM continuous forms printer
 compatibility 36
 negotiable documents 37
 OCR documents 45
 outgassing 36

ink recommendations (*continued*)
preprinted forms 35
solid areas 36
vapor emissions 36
vertical lines 36
International Organization for
Standardization (ISO)
test reference 19

L

labels
bar codes 45
design requirements 42
odors, caused by 54
physical discomfort 54
pressure sensitive 43
printing 41
safety practices 54
types 41
using coated and synthetic 44
weight and thickness 43
laminated
labels 41
lean, stack 8
ledger paper
fusing, effects on 31
special ledger for OCR 45
location, binder holes 39

M

moisture
content 31
paper 31
multiple-lot test 50

N

negotiable documents
checks 37
document processing 45
folded 38
marginal fusing of toner 38
safeguards 37

O

offset paper
fusing, effects on 31
operating environment, forms 20
optical character recognition (OCR)
fonts 45
forms 45
testing 48
orientation, bar-codes on labels 45
outgassing, preprinted forms 36

P

packaging
cartons 19
cartons, height 19
manufacturers' splices 19
packing 19
storage
stacking boxes 20

packaging (*continued*)
storage (*continued*)
temperature and humidity 20
page uniformity
perforations
horizontal 6
vertical 6
tractor holes
in left and right margins 6
spacing from 6

pallet

storing shipping boxes on 20

paper

blended 27
bond, description of 27
break, causes 17
characteristics to avoid
additives, fillers 28
adhesive additives 28
calender cuts 28
chads 31
coated 28
containing plastics 28
cuts and tears 28
dust 28, 31
fillers, additives 28
salts or metallic compounds 28
waxy surface 28
wrinkles 28

colors 46

labels 41

moisture content 31

odors 53

operating environment 20

packaging 19

physical discomfort 53

preprinted forms, paper to use 35

quality 27

recommendations 31

recycled 27

reverse-side printing 51

safety practices 53

security, papers used in the
electrophotographic process 45

security, use 37

shipping environment 20

single ply, use of 2

smoothness 31

special 37

special bond for OCR 45

stack lean test 8

stacking reliability 29

storage environment 20

using special paper 37

weight 29

weight, fusing considerations 31

which may cause odors 28

paper recommendations, 600 pel printers
21

perforations

accuracy of 13

cuts and ties, ratio 16

dishing, effect of 11

embossing 16

fold memory 15

folding, memory of 12

stack lean 8

perforations (*continued*)

strength 16

testing 18

vertical and horizontal, location 7

photoconductor

effects of using embossed paper 28

platen, preheat

fusing considerations, lighter paper
31

polymer

softening with heat 30

porosity 31

preface

terminology 1

preprinted forms

ink recommendations 35

ink transfer to IBM continuous forms

printer 36

negotiable documents 37

odors 53

outgassing 36

paper to use 35

physical discomfort 53

vapor emissions 36

prepunched forms 39

print

area 4

printer

impact 37

printing, advanced function 37, 53

promotional letters 37

R

recommendations, paper selection 31

recycled, paper 27

requirements

environment 20

paper dimension 6

perforation

strength 16

resistivity, surface 31

restrictions

16 pound paper 29

bar code documents 45

binder holes 41

corner cuts 41

cutouts 41

guidelines 36

OCR documents 45

packaging 19

paper sizes, weight 29

perforations

binder holes 39

cutouts 39

testing 18

reverse-side printing 51

specialty papers and inks

negotiable documents 37

smoothness 30

stack lean 8

temperature and humidity 20

restrictions, binder holes 39

running perforations 2, 17

S

- safety practices for paper, forms, inks, and labels 53
- sample production run test 50
 - troubleshooting 51
- screen
 - preprinted solid areas 36
 - preprinted tinting inks 36
- selecting
 - forms 27, 31
 - forms, high-resolution printers 21
 - paper 27, 31
 - paper, high-resolution printers 21
 - preprinted forms 31
 - recommendations 31
 - table 31
- sheffield 31
- Sheffield smoothness 43
- single-box test 49
- size, binder holes 39
- sizing
 - internal 31
 - surface 31
 - which may cause fusing failures 28
- smoothness
 - bond paper 30
 - forms 30, 31
 - high-bulk bond 30
 - Sheffield 43
 - specialty paper 30
- special applications and materials 39
- specialty papers and inks
 - direct mail advertising 37
 - negotiable documents
 - checks 37
 - promotional letters 37
 - safeguards 37
- specifications, forms
 - forms 23, 25
- stack lean
 - measuring 8
 - testing 8
- stacker
 - capacity 19
 - moisture, effects of 20
 - performance 8
 - performance of 13, 15
- static friction 31
- stiffness 31
- storage environment, forms 20
- surface resistivity 31

T

- taber 31
- TAPPI
 - test reference 19
- terminology 1, 55, 57
- test
 - applications testing 47
 - evaluating results 49
 - multiple-lot test 50
 - perforation
 - equipment 18
 - method 18
 - references 19
 - sample production run test 50

- test (*continued*)
 - single-box test 49
 - stack lean 8
- testing forms and applications 47, 49
- tie
 - cuts and ties, ratio 16
 - definition 16
 - embossing 16
 - minimum length for internal perforations 17
- toner
 - fusing 37
- tractor holes
 - accuracy of drilling 12
 - tolerances 6
- transfer
 - inks to printer components 35
 - multicolored inks 37
 - vertical lines 36

U

- uniformity, page 6

V

- vapor emissions, preprinted forms 36
- ventilation 53, 54
- void
 - causing misfeeds 28

W

- web
 - avoid tearing 19
 - avoiding breakage 7
 - moisture changes 20

Readers' Comments — We'd Like to Hear from You

Continuous Forms
Advanced Function Printers
Forms Design Reference

Publication No. G544-3921-05

Overall, how satisfied are you with the information in this book?

	Very Satisfied	Satisfied	Neutral	Dissatisfied	Very Dissatisfied
Overall satisfaction	<input type="checkbox"/>	<input type="checkbox"/>	<input type="checkbox"/>	<input type="checkbox"/>	<input type="checkbox"/>

How satisfied are you that the information in this book is:

	Very Satisfied	Satisfied	Neutral	Dissatisfied	Very Dissatisfied
Accurate	<input type="checkbox"/>	<input type="checkbox"/>	<input type="checkbox"/>	<input type="checkbox"/>	<input type="checkbox"/>
Complete	<input type="checkbox"/>	<input type="checkbox"/>	<input type="checkbox"/>	<input type="checkbox"/>	<input type="checkbox"/>
Easy to find	<input type="checkbox"/>	<input type="checkbox"/>	<input type="checkbox"/>	<input type="checkbox"/>	<input type="checkbox"/>
Easy to understand	<input type="checkbox"/>	<input type="checkbox"/>	<input type="checkbox"/>	<input type="checkbox"/>	<input type="checkbox"/>
Well organized	<input type="checkbox"/>	<input type="checkbox"/>	<input type="checkbox"/>	<input type="checkbox"/>	<input type="checkbox"/>
Applicable to your tasks	<input type="checkbox"/>	<input type="checkbox"/>	<input type="checkbox"/>	<input type="checkbox"/>	<input type="checkbox"/>

Please tell us how we can improve this book:

Thank you for your responses. May we contact you? Yes No

When you send comments to IBM, you grant IBM a nonexclusive right to use or distribute your comments in any way it believes appropriate without incurring any obligation to you.

Name

Address

Company or Organization

Phone No.



Cut or Fold
Along Line

Fold and Tape

Please do not staple

Fold and Tape



NO POSTAGE
NECESSARY
IF MAILED IN THE
UNITED STATES

BUSINESS REPLY MAIL

FIRST-CLASS MAIL PERMIT NO. 40 ARMONK, NEW YORK

POSTAGE WILL BE PAID BY ADDRESSEE

IBM Corporation
IBM Printing Systems Company
Department H7FE, Building 003G
Information Development
P.O. Box 1900
Boulder, CO USA 80301-9817

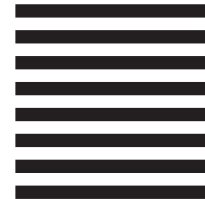

Fold and Tape

Please do not staple

Fold and Tape

Cut or Fold
Along Line



Part Number: 63H6629



Printed in the United States of America
on recycled paper containing 10%
recovered post-consumer fiber.

6544-3921-05



63H6629

