

IBM Tivoli NetView for z/OS Enclave Exploitation New Subsystem Type NETV

Jürgen Holtz
IBM Germany
Schönaicher Str. 220
D-71032 Böblingen
✉ holtz@de.ibm.com

IBM @server. For the next generation of e-business.

© IBM Corporation 2002

Copyright And Trademarks

(c) Copyright IBM Corporation 2002

The following names are trademarks of the IBM Corp. in USA and/or other countries and may be used throughout this presentation:

CICS, DB2, eLiza, IBM, IMS, MVS/ESA, MQSeries, NetView,
RMF, RACF, S/390, Tivoli, VTAM, VSE/ESA, VM/ESA,
WebSphere, z/OS, z/VM, zSeries

Other company, product and service names may be trademarks or service marks of others.

IBM @server. For the next generation of e-business.

© IBM Corporation 2002

WLM Management of NetView Subtasks

- NetView optionally allows you to let WLM manage NetView subtasks in relation to other tasks and applications running on the system or sysplex
- If enabled, NetView creates enclaves during subtask initialization and calls WLM to classify a subtask to the appropriate service class
- Enable WLM support
 - ▶ `WLM.SubSystemName=<subsysname>` in DSIPARM member CNMSTYLE
- Support available with IBM Tivoli NetView for OS/390 V1R4 and higher

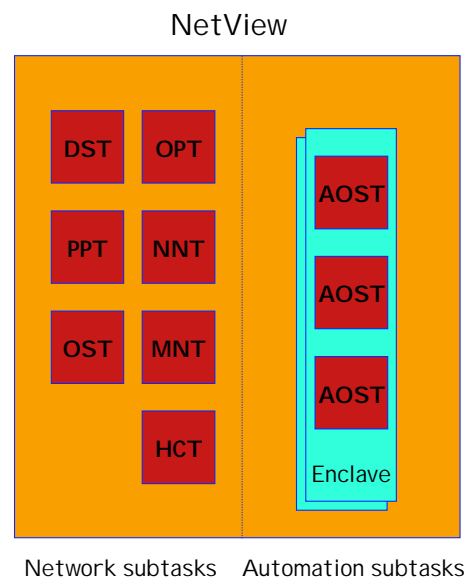

IBM @server. For the next generation of e-business.

© IBM Corporation 2002

- ▶ You can optionally use the z/OS Workload Manager (WLM) to manage NetView subtask performance in relation to other tasks and applications running on the system or sysplex. The NetView program uses WLM to balance the workload between NetView tasks.
- ▶ When WLM is enabled, NetView calls WLM during subtask initialization and passes it the subtask information to allow WLM to assign it to the appropriate service class. The service classes should be assigned a velocity goal. Automation subtasks should run in a service class with a higher importance than the service class network subtasks are running in.
- ▶ The WLM support is enabled, when the WLM statement

`WLM.SubSystemName=<subsystem instance>`

is uncommented in the DSIPARM member CNMSTYLE. The default subsystem instance name corresponds to the NetView domain name (&DOMAIN).

- ▶ For a detailed description how to enable workload management support, refer to *Tivoli NetView for z/OS Installation: Configuring Additional Components* (SC31-8874-00) and to *z/OS MVS: Planning Workload Management* (SA22-7602-00).
- ▶ When a user decides to separate the management of NetView's network and system automation (SA) subtasks, NetView creates z/OS enclaves to manage those two sets of subtasks so that users can assign different performance goals to the enclaves. "Network" subtasks include all those not connected with system automation.

These two types of NetView enclaves should be classified to service classes with velocity goals. The goals should have approximately the same velocity value, but the goal assigned to NetView system automation enclaves should be more important than the goal assigned to any NetView network enclaves. There is no need to define a separate service class for NetView, if existing service classes in your service definition satisfy these conditions. For example, if SA/390 or other system automation is used, a goal of Velocity = 50 and an Importance of 1 could be assigned. For non-system automation NetView subtasks, a goal of Velocity = 30 and an Importance of 2 could be assigned to give preference to the system automation NetView subtasks.

Goals and Classification

- Service class goals
 - ▶ Automation subtasks: single period, medium to high velocity, importance 1
 - ▶ Network subtasks: single period, medium velocity, importance 2
 - ▶ Reuse existing service classes, if characteristics match
- Supported classification attributes
 - ▶ LU name and netid (LU)
 - ▶ Priority (PRI)
 - ▶ Subsystem instance (SI)
 - ▶ Transaction class / job class (TC)
 - ▶ Transaction name / job name (TN)
 - ▶ Userid (UI)
- Notes:
 - ▶ Classification attributes are *not* validated by WLM ISPF application
 - ▶ If NetView enclaves are not classified by the installation, they run in SYSOTHER (goal mode)

IBM @server. For the next generation of e-business.

© IBM Corporation 2002

- ▶ For subsystem type NETV, the classification attributes have the following meaning:
 - ▶ **LU name and netid:** the LU name and the netid associated with the NetView subtask.
 - ▶ **Priority:** indicates a number between 1 and 9 that defines the dispatching priority of this task in relation to other subtasks running in this NetView program. For more information, see *Tivoli NetView Administration Reference*.
 - ▶ **Subsystem instance:** the NetView WLM subsystem name as coded in CNMSTYLE. This is usually the NetView domain name. For more information, see *Tivoli NetView Administration Reference*.
 - ▶ **Transaction class / job class:** the NetView subtask type. Valid types are: AOST, DST, HCT, MNT, NNT, OPT, OST, and PPT. For more information, see *Tivoli NetView Customization: Using Assembler*.
 - ▶ **Transaction name / job name:** the NetView subtask module name. For more information, see the NetView TASK statement description in the *Tivoli NetView Administration Reference*.
 - ▶ **Userid:** the NetView subtask ID. For NetView OST and NNT subtasks this is the NetView operator ID. For more information, see *Tivoli NetView User's Guide*.
For AOST (automation subtasks) this is the NetView operator ID on the AUTOTASK command that started the AOST. For more information, see *Tivoli NetView Command Reference*.
For NetView DST and OPT subtasks this is the taskname on the NetView TASK statement. For more information, see the *Tivoli NetView Administration Reference*.
The MNT subtask ID is MNT. The PPT subtask ID is the NetView domain ID concatenated with the characters "PPT".
The HCT subtask ID is the same as its LU name which is specified on the HARDCOPY statement. For more information, see *Tivoli NetView Administration Reference*.
- ▶ **Important Notices:**
 - ▶ Do not forget to add the subsystem type NETV to your service definition (option 6 in ISPF application). The absence of classification rules for subsystem type NETV will result in the NetView enclaves being classified to service class SYSOTHER, if the NetView WLM support is enabled.
 - ▶ For the subsystem type NETV, no validation of the classification attributes is done by the ISPF application. Please, use only a combination of the attributes described above.