

IBM zEnterprise System

# IT Optimization and Consolidation with IBM zEnterprise

Reducing Costs and Accelerating Business Success

# Trademarks

The following are trademarks of the International Business Machines Corporation in the United States and/or other countries.

IBM*	DB2 Connect	POWER*	Tivoli*	z9*
IBM eServer	Domino*	POWER7*	WebSphere*	z10
IBM Logo*	GDPS*	pSeries*	XIV*	z/OS*
AIX*	HiperSockets	System Storage	z/Architecture*	z/VM*
BladeCenter*	Informix*	System z*	zEnterprise	
CICS*	IMS	System z9*		
Cognos*	MQSeries*	System z10		
DB2*	Parallel Sysplex*			

\* Registered trademarks of IBM Corporation

## The following are trademarks or registered trademarks of other companies.

Adobe, the Adobe logo, PostScript, and the PostScript logo are either registered trademarks or trademarks of Adobe Systems Incorporated in the United States, and/or other countries. Cell Broadband Engine is a trademark of Sony Computer Entertainment, Inc. in the United States, other countries, or both and is used under license therefrom.

Java and all Java-based trademarks are trademarks of Sun Microsystems, Inc. in the United States, other countries, or both.

Microsoft, Windows, Windows NT, and the Windows logo are trademarks of Microsoft Corporation in the United States, other countries, or both.

INFINIBAND, InfiniBand Trade Association and the INFINIBAND design marks are trademarks and/or service marks of the INFINIBAND Trade Association.

Intel, Intel logo, Intel Inside, Intel Inside logo, Intel Centrino, Intel Centrino logo, Celeron, Intel Xeon, Intel SpeedStep, Itanium, and Pentium are trademarks or registered trademarks of Intel Corporation or its subsidiaries in the United States and other countries.

UNIX is a registered trademark of The Open Group in the United States and other countries.

Linux is a registered trademark of Linus Torvalds in the United States, other countries, or both.

ITIL is a registered trademark, and a registered community trademark of the Office of Government Commerce, and is registered in the U.S. Patent and Trademark Office.

IT Infrastructure Library is a registered trademark of the Central Computer and Telecommunications Agency, which is now part of the Office of Government Commerce.

\* All other products may be trademarks or registered trademarks of their respective companies.

### Notes:

Performance is in Internal Throughput Rate (ITR) ratio based on measurements and projections using standard IBM benchmarks in a controlled environment. The actual throughput that any user will experience will vary depending upon considerations such as the amount of multiprogramming in the user's job stream, the I/O configuration, the storage configuration, and the workload processed. Therefore, no assurance can be given that an individual user will achieve throughput improvements equivalent to the performance ratios stated here.

IBM hardware products are manufactured from new parts, or new and serviceable used parts. Regardless, our warranty terms apply.

All customer examples cited or described in this presentation are presented as illustrations of the manner in which some customers have used IBM products and the results they may have achieved. Actual environmental costs and performance characteristics will vary depending on individual customer configurations and conditions.

This publication was produced in the United States. IBM may not offer the products, services or features discussed in this document in other countries, and the information may be subject to change without notice. Consult your local IBM business contact for information on the product or services available in your area.

All statements regarding IBM's future direction and intent are subject to change or withdrawal without notice, and represent goals and objectives only.

Information about non-IBM products is obtained from the manufacturers of those products or their published announcements. IBM has not tested those products and cannot confirm the performance, compatibility, or any other claims related to non-IBM products. Questions on the capabilities of non-IBM products should be addressed to the suppliers of those products.

Prices subject to change without notice. Contact your IBM representative or Business Partner for the most current pricing in your geography.

## Discussion Topics

- **Business drivers for IT optimization and consolidation**
- **Linux® on IBM System z® marketplace dynamics**
- **Smarter optimization and consolidation with IBM zEnterprise™**
  - Consolidate more, spend less
  - Optimize workloads across architectures
  - Manage and govern for business success
- **Customer success stories**

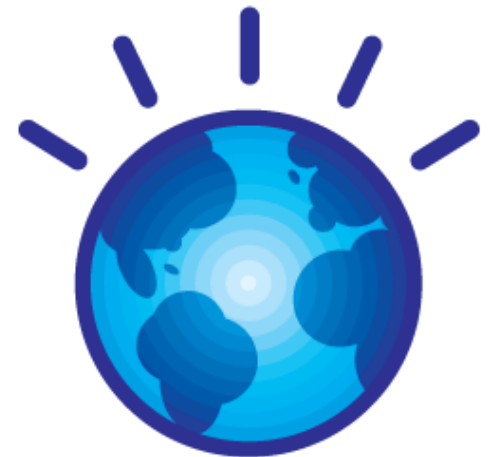

# A Typical IT Infrastructure Hinders Competitiveness

*Businesses spend too much time and money managing their assets instead of managing their business!*

- Islands of computing create organizational inefficiencies
- IT complexity constrains business responsiveness

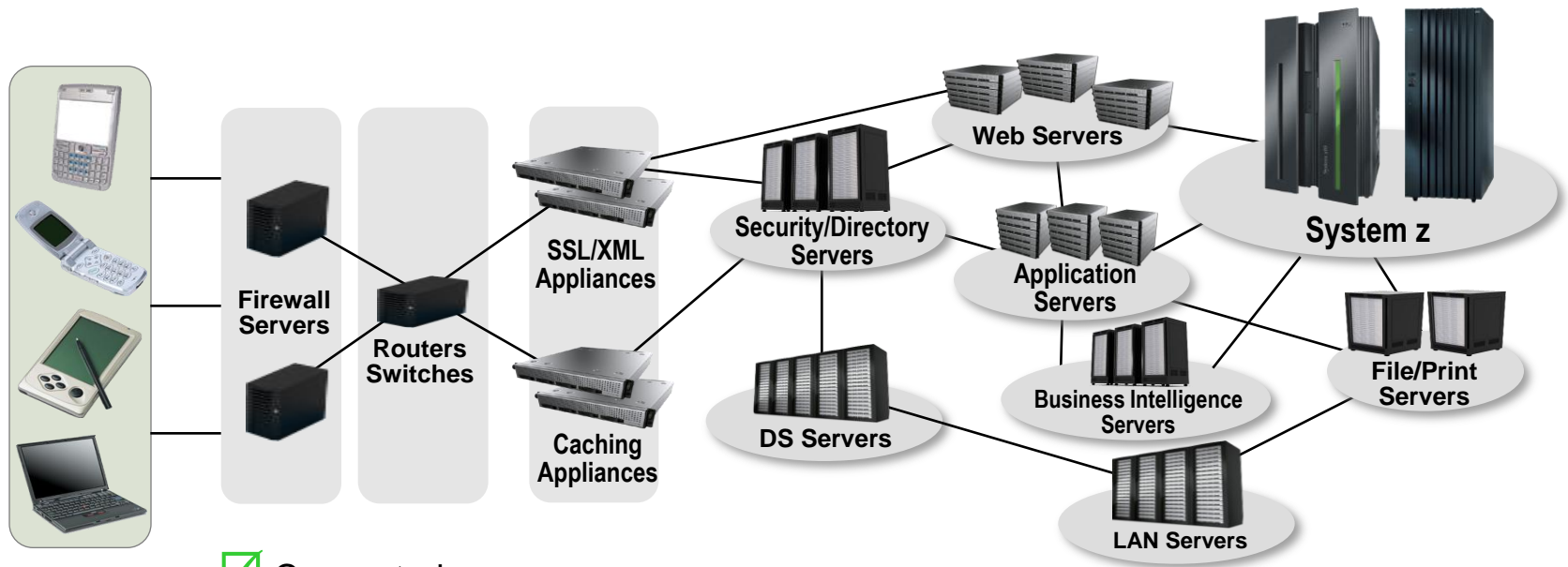

- ✓ Connected
- ✗ Integrated
- ✗ Flexible, Dynamic, and Responsive
- ✗ Aligned with Business Objectives

# A Smarter IT Infrastructure Addresses Today's Challenges... and Tomorrow's Opportunities



## REDUCE COST

---

Not just containing operational cost and complexity, but achieving *breakthrough* productivity gains through virtualization, optimization, energy stewardship, and flexible sourcing.

## IMPROVE SERVICE

---

Not only ensuring high availability and quality of existing services, but also meeting customer expectations for real-time, dynamic access to innovative *new* services.

## MANAGE RISK

---

Not only addressing today's security, resiliency, and compliance challenges, but also preparing for the new risks posed by an even more *connected* and *collaborative* world.

# IT Optimization and Consolidation

## IBM 2009 CIO survey results

CIOs select their ten most important visionary plan elements



# 76%

of CIOs cited “implementing a virtualized computing environment” as part of their visionary plans to enhance competitiveness.

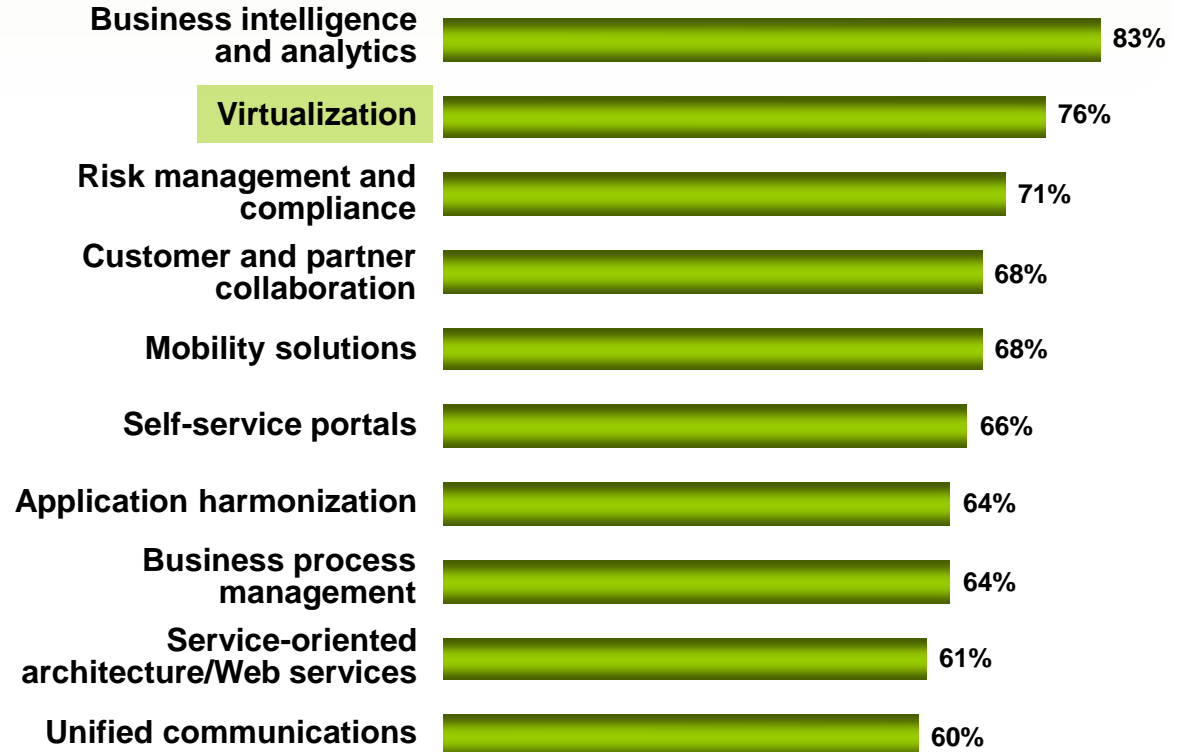

Note: CIOs were asked to select all applicable answers to the question, “What kind of visionary plans do you have for enhanced competitiveness?”

# Maximizing Utilization of Resources

- Up to 100% server utilization compared to 10-20% distributed server utilization<sup>1</sup>
- Shared everything infrastructure allows for maximum utilization of resources
  - CPU, Memory, Network, Adapters, Cryptography, Devices

Lowers resources  
for each work unit

Customer savings

**Underutilized distributed servers**

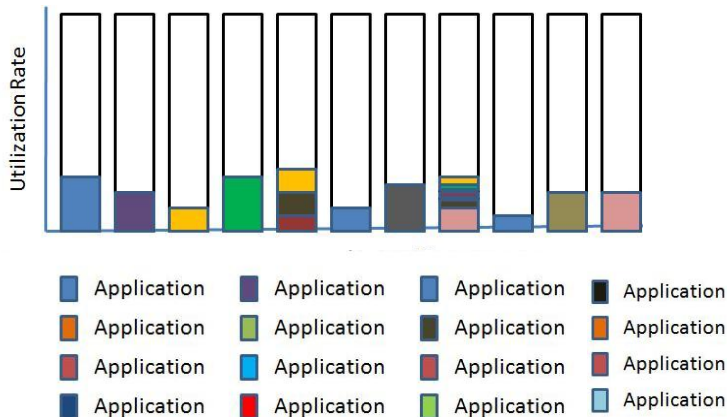

**Up to 100% utilized server**

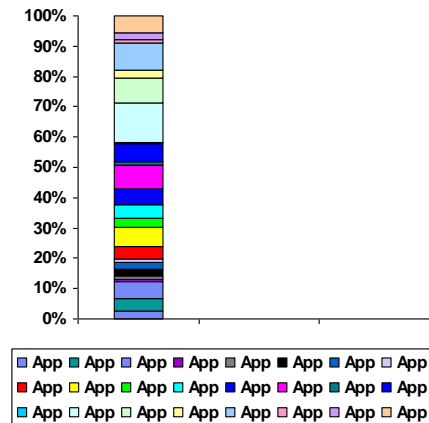

Typically single application per server

Multiple applications on single server

<sup>1</sup> Source: gomainframe.com Joe Clabby

By Liz Benison of Capgemini | 29 September 2009 | CIO UK

## ***Mainframe computing is set for a rebirth***

There are several reasons why this is so...

- **Reliability** is of course on the list, with many machines having a record of a decade or more **running without interruption**...
- **Availability** is another fact ... often being considered as the **rock-bottom starting point**...
- ...**unmatchable security** features, the **high inbuilt redundancy** and **disaster recovery**, the **extensive input-output** facilities...
- ...the **sheer processing power** and MIPS rating that supports the **massive throughput**...
- One reason is the current interest in **cloud computing and virtualization** ... often touted as brand-new – have been **realities in the mainframe world for decades**.

Clearly the **availability of open source** (...) systems and applications software such as **Linux** provided as a standard facility **has given the mainframe a major boost**, with such options proving popular across all sectors including public.



# What is a zEnterprise System ?



## IBM zEnterprise 196 (z196)

- *Optimized to host large scale database, transaction, and mission critical applications*
- *The Most efficient platform for Large-scale Linux consolidation*
- *Capable of massive scale up*
- *New easy to use z/OS V1.12*

## zEnterprise Unified Resource Manager

- *Unifies management of resources, extending IBM System z qualities of service end-to-end across workloads*
- *Part of the IBM System Director family, provides platform, hardware and workload management*

## zEnterprise BladeCenter Extension (zBX)

- *Selected IBM POWER7 blades and IBM System x Blades\* for tens of thousands of AIX and Linux applications*
- *High performance optimizers and appliances to accelerate time to insight and reduce cost*
- *Dedicated high performance private network*

# IBM zEnterprise System

*Delivers Superior IT Optimization and Consolidation for Your Enterprise*

## Reduce Cost



zEnterprise delivers superior **resource sharing** and **virtualization efficiency** – helping users optimize their spending on energy, floor space, software, and staffing.

## Improve Service



zEnterprise provides an extensive set of time-tested **command and control** functions that help users maintain service agreements during peak periods and satisfy business demands with incredible **speed and agility**.

## Manage Risk



zEnterprise offers unrivaled **system availability** and flexible business continuance and disaster recovery options to help clients protect their business.

zEnterprise offers a clear advantage because it delivers better business value in these key areas

– **Plus** –

zEnterprise integrates and manages multiple server architectures for optimal application placement

# Smarter Virtualization with the IBM Enterprise Linux Server

- **x86 virtualization solutions have some hidden and some not-so-hidden issues**
  - Physical server sprawl is needed to scale a virtualized x86 environment – typically with linear, per-machine pricing
  - x86 virtual machine sprawl can be difficult to manage, causing operational complexity
  - Ineffective capacity planning can result in failure to meet service level agreements
  - Limited core-to-core consolidation ratios and virtual machine mobility requirements can lead to costly software fees
  - x86 systems do not have a heritage of robust security support
  - Duplication of hardware and is needed for disaster recovery
- **Enterprise Linux Server provides a superior scale-up system architecture for scale-out x86 applications**
  - Dynamically expand your system “on demand” – add capacity when you need it, not any sooner, not any later
  - Enjoy superior operational capabilities for greater levels of command and control
  - Total Cost of Ownership economics favor server virtualization on an Enterprise Linux Server, especially when factoring in disaster recovery and server technology refreshes



**Consolidate more and  
spend less with the  
Enterprise Linux Server**

# Reasons for Running Linux on IBM System z

**Mainframe reliability** is the top driver for running Linux on System z, followed by: cost savings, z/VM<sup>®</sup> virtualization capabilities and application availability

The most important **z/VM capabilities** are rapid deployment of Linux virtual machines and high server consolidation ratio

## Key Factors in Running Linux on Mainframe

Base: Running Linux on mainframe

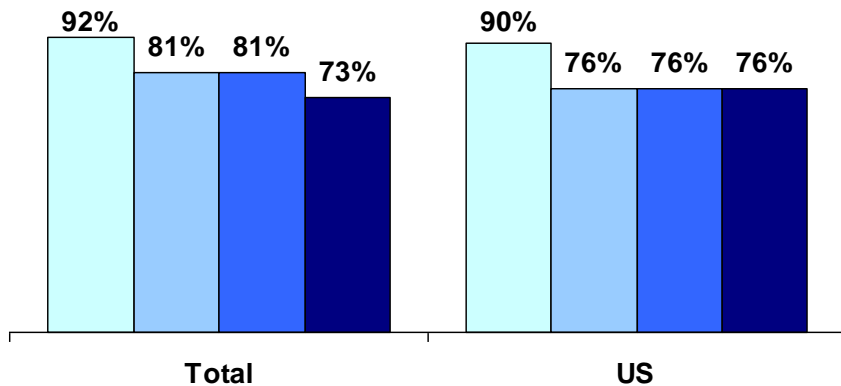

- Mainframe reliability
- Cost savings
- z/VM virtualization capabilities
- Application availability

## z/VM Capabilities Valuable for Running Linux on Mainframe

Base: Those who consider z/VM capabilities a key factor in running Linux on mainframe

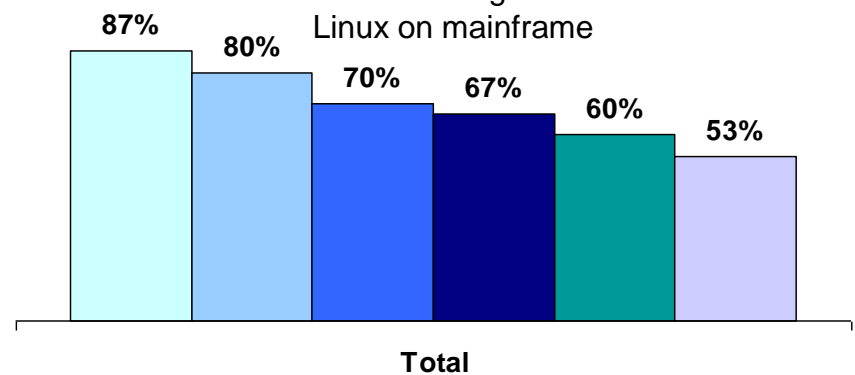

- Rapid deployment of Linux virtual machines
- High server consolidation ratio
- Virtual networking
- Staff productivity
- Data sharing
- System management features and functions

# Architectures are different !

System z uses SAPS ! (System assist processors for IO)

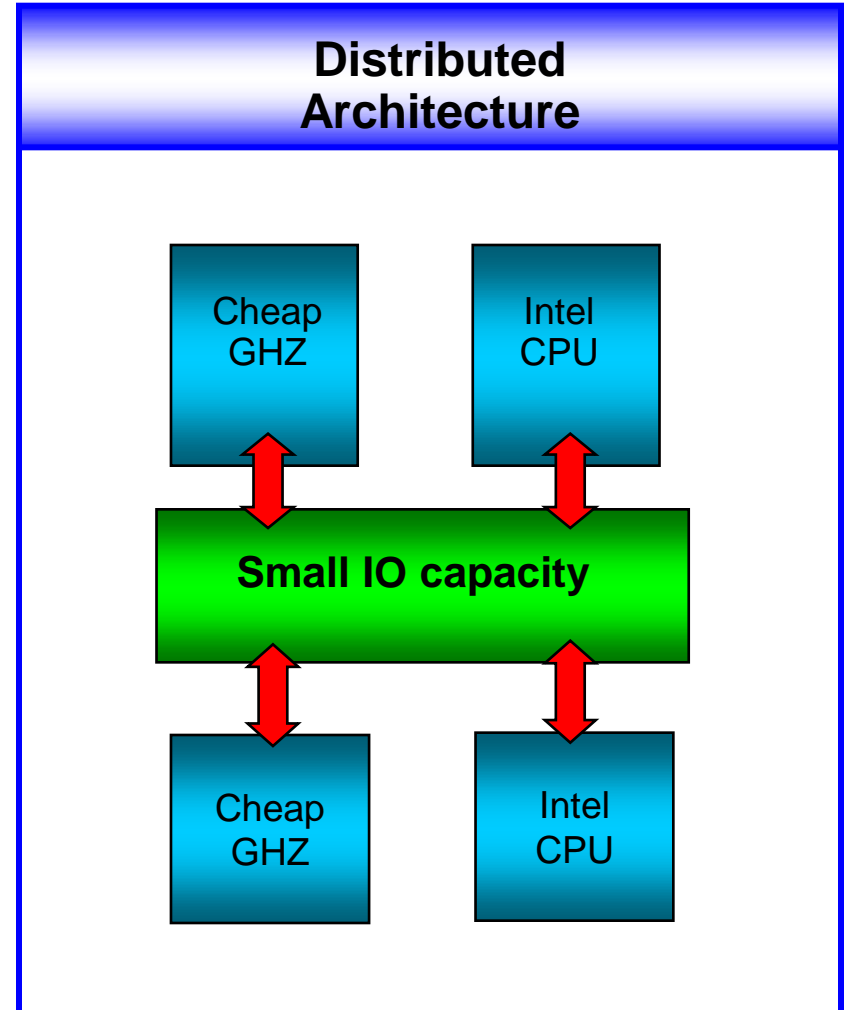
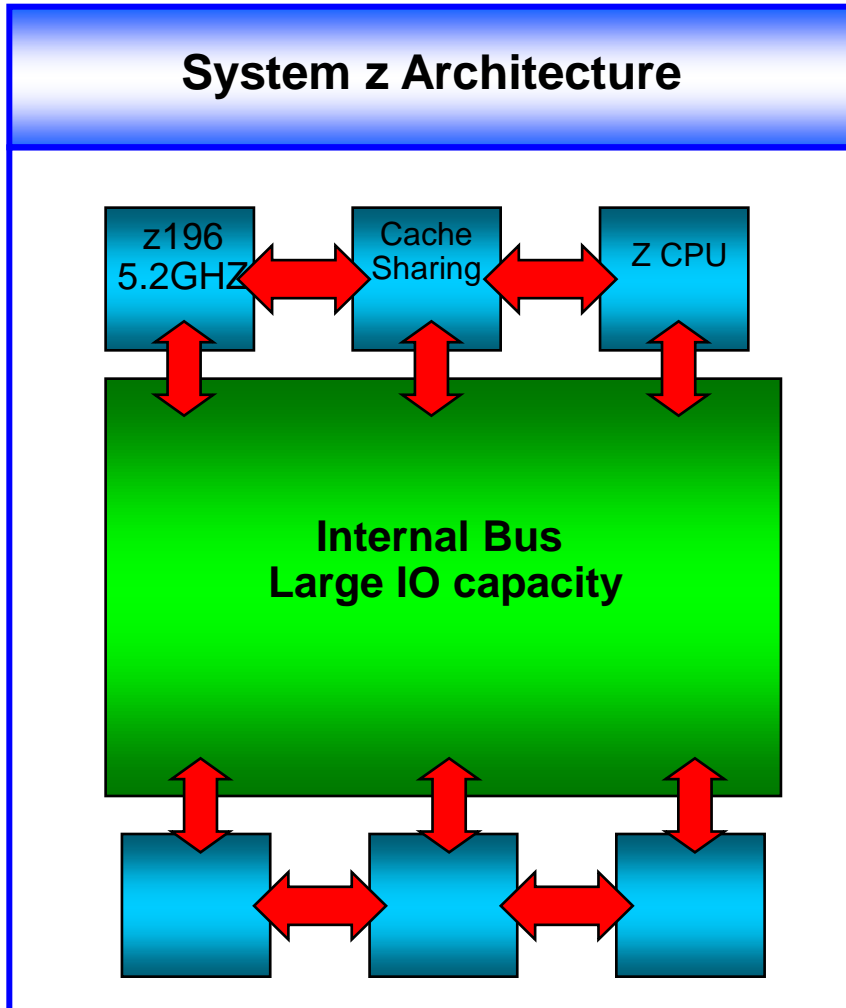

# System z's Extreme Virtualization

- Built into the architecture not an “add on” feature

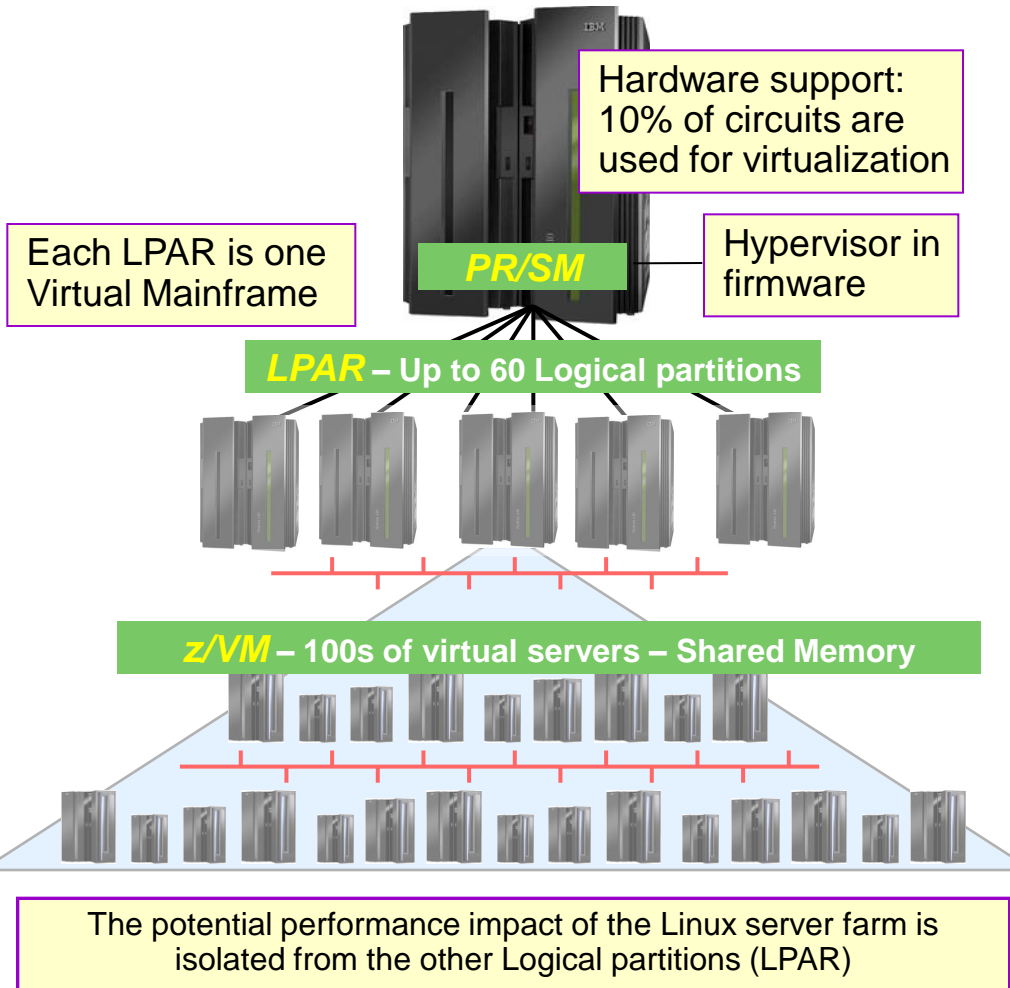

## System z

**Deploy** virtual servers in seconds

**\$1K/server** over 3 years

Highly **granular** resource sharing (<1%)

Add physical resources without taking system down, scale out to **1000s** of virtual servers

**Do more with less:**

More virtual servers per core,  
Share more physical resources across servers

Extensive built-in facilities for virtual server **life-cycle management**

**Hardware-enforced isolation**

## Distributed Platforms

Limited per-core virtual server scalability

Physical server sprawl is needed to scale

Operational complexity increases as virtual server images grow

VMware tools only support VMware hypervisor (ESX)

# Linux on System z: Consolidation vs. New Applications

**Q:** Are you using Linux on System z to consolidate workloads, host new applications or both?

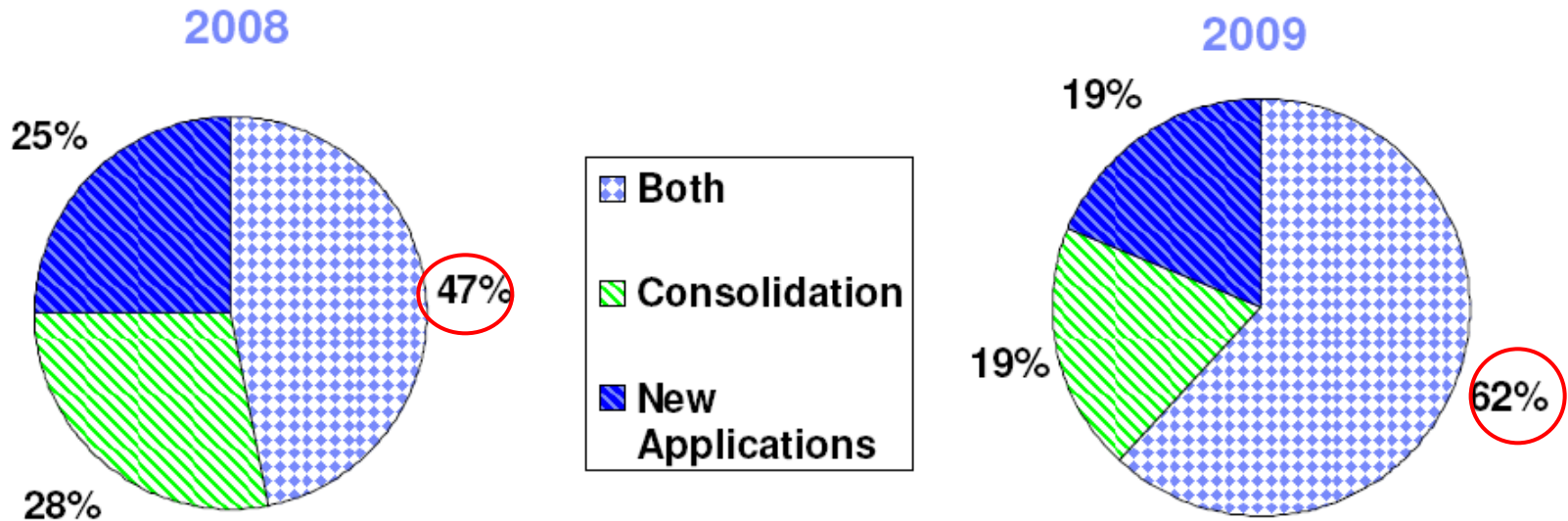

Many users start with a Linux consolidation project or deploy new applications, and then expand their use of Linux on System z to do both.

# Linux on System z Technology Refreshes

*Forklift Upgrades: Fast, Easy, Upwardly Compatible*



**IBM System z10**



**IBM zEnterprise System**

“One of the key advantages we see of running Linux on System z is as new generations of hardware technology are introduced, we’re able to basically do a forklift upgrade – we don’t have to re-certify applications as we have had to do on other platforms in the past.”

– IT Manager, Delivery Industry Company



# z10 IFL TCO Case Study: 5-year TCO of Financial Services Workload



- Intel costs 3.3 time more than System z10
- Intel with VMWare costs 2.7 times more than System z10

**Accumulated Cost**

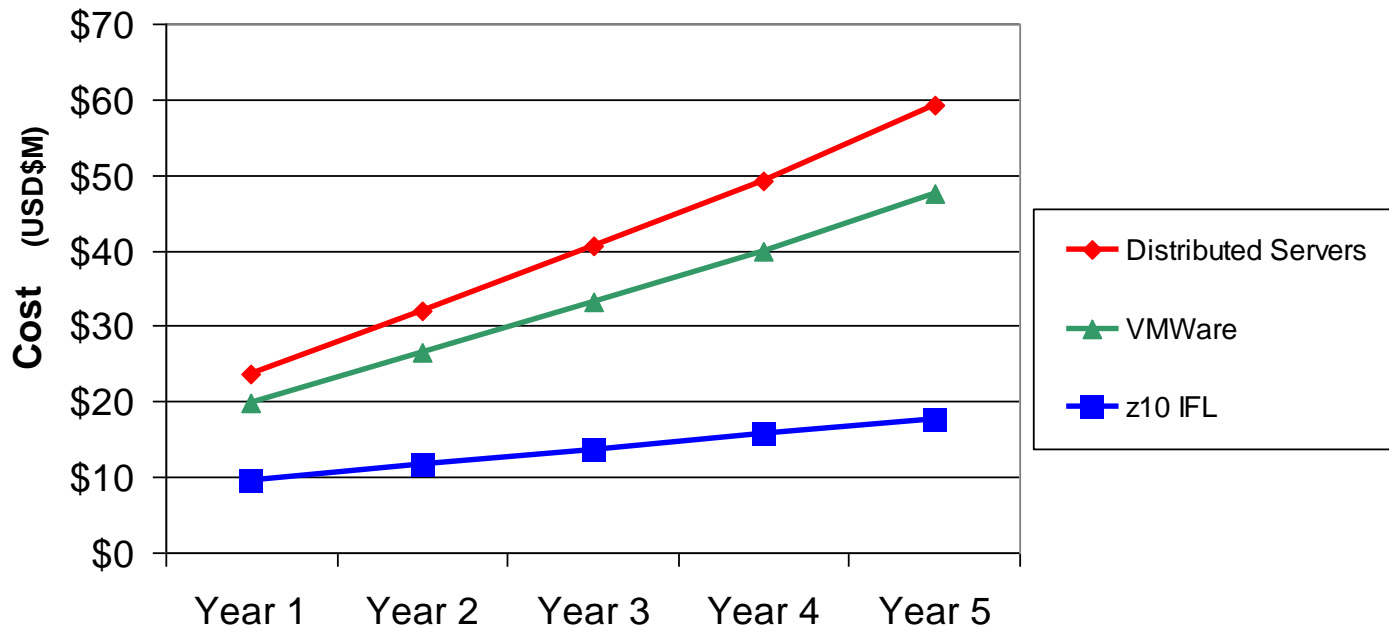

# z10 IFL TCO Case Study: Financial Services Workload TCO Comparison



## System z10 Reduces Costs Significantly

System z10 with z/VM and Linux	Cost reduction vs Intel servers	Cost reduction vs VMWare
<b>Total Cost of Ownership</b>	<b>70%</b>	<b>63%</b>
<b>Cost of Energy</b>	<b>96%</b>	<b>82%</b>
<b>Cost of People</b>	<b>86%</b>	<b>72%</b>
<b>Cost of Network</b>	<b>87%</b>	<b>36%</b>
<b>Cost of Software</b>	<b>77%</b>	<b>82%</b>

**Cost of Running Financial Services Workload**  
5-year Total Cost of Ownership

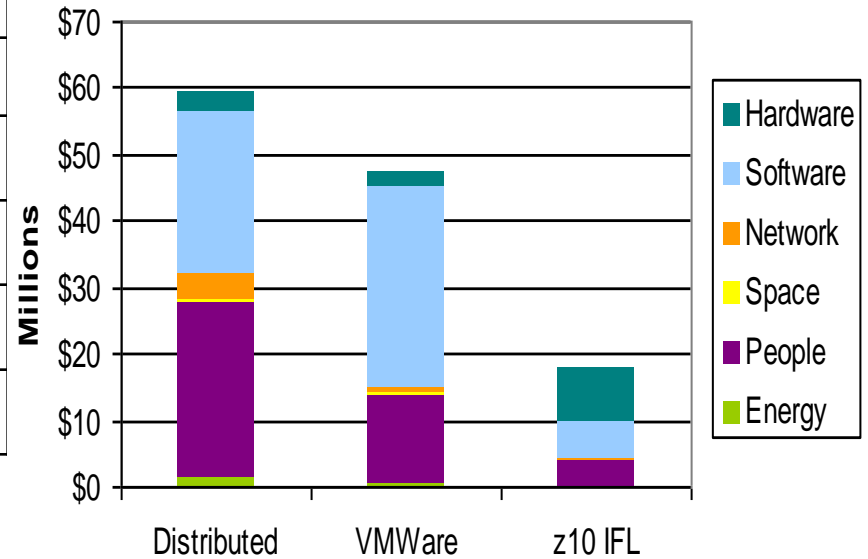

# zEnterprise: Service Levels to Match Your Business Needs

*Increased flexibility for your multi-tier, multi-architecture strategy*

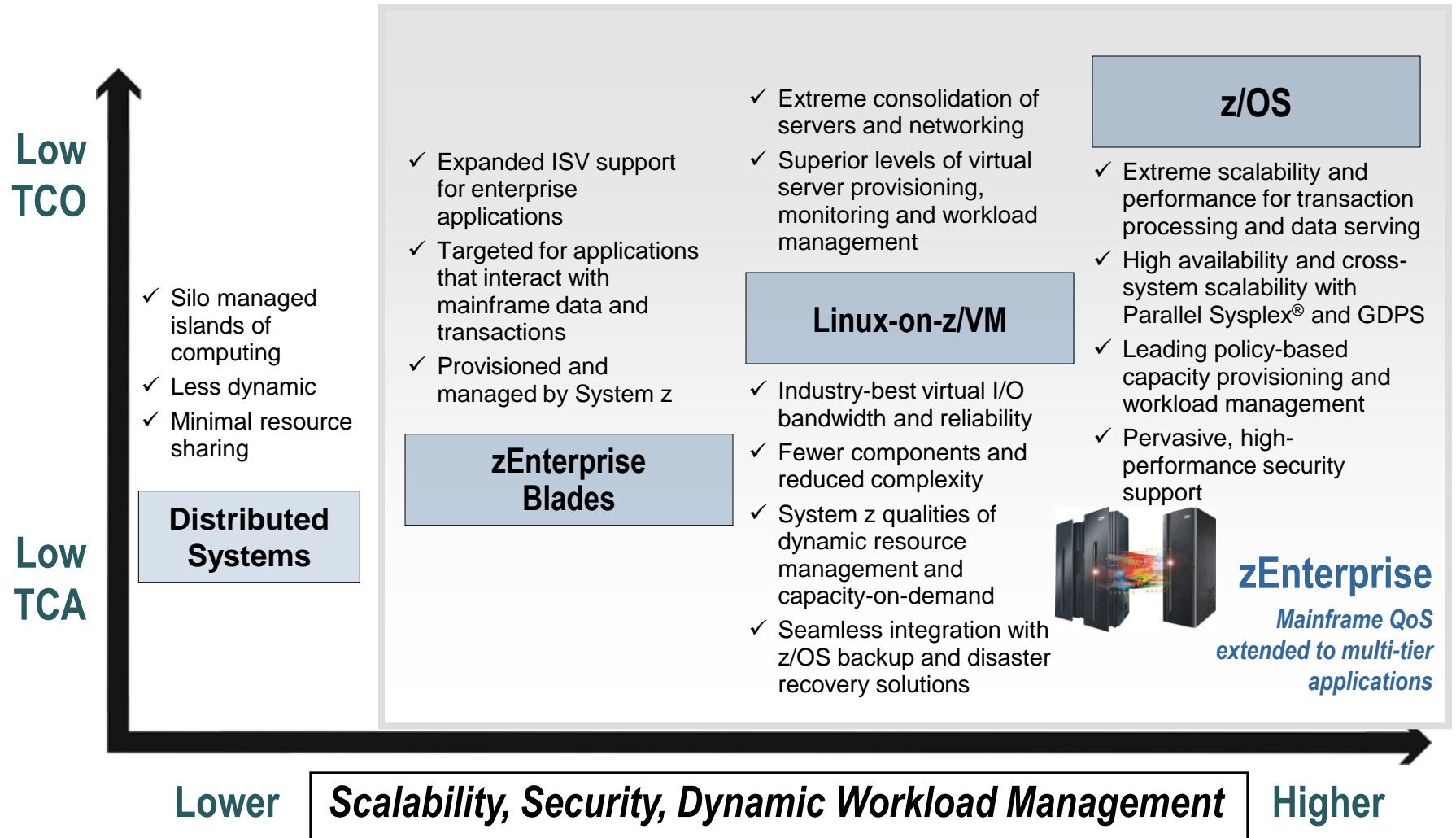

## Support growth with green savings

**60**  
Wintel  
servers

**Energy**  
**40kVA**

**\$1m**  
Savings  
in  
facilities,  
hardware  
& software  
costs



Production  
cutover  
**48 hrs**  
Zero impact  
to customers

**1**

**4kVA**  
**-90%**

Investment paid back in just over a year

## BENEFITS to Clients

Comparison to Distributed



Allianz Australia Limited offers a wide range of insurance and risk management products and services.

# Baldor Electric Company

## Consolidation on IBM System z10 Cuts Complexity and Cost

### Business challenge:

When Baldor Electric acquired its major competitor, Reliance Dodge, it also acquired hundreds of separate servers that cost money, time and effort to support and maintain. Baldor Electric aimed to reduce IT costs, which meant reducing complexity, consolidating systems and simplifying the software landscape. The company wished to integrate the two organizations as rapidly and cost-effectively as possible.

### Solution:

Baldor consolidated to SAP Business Suite, hosted on 70 virtual machines running SUSE Linux Enterprise Server on the IBM System z10 Enterprise Class platform. Where previously Reliance Dodge relied on overnight batch processes to synchronize data on different servers, the SAP applications on z10™ provide an always-up-to-date picture of current business. Baldor also migrated data from separate storage systems to the IBM System Storage™ DS8100 platform.

### Benefits:

- Cut IT costs by 50 percent as a proportion of sales, while maintaining ultra-high availability
- Eliminated more than 200 stand-alone servers
- Cut electricity costs by 60% and floor-space requirements by 50%

*“We have freed up an area of about 3,000 sq. ft., which is now being turned into office space. This has also dramatically reduced the power and cooling requirements of our infrastructure – cutting electricity costs by 60 percent.”*

— Mark Shackelford, Director of IT Services at Baldor Electric

### Solution components:

- IBM System z10 EC
- IBM System Storage DS8100
- IBM DB2
- IBM z/OS
- IBM z/VM
- SAP Business Suite
- SUSE Linux Enterprise Server

## Bank of New Zealand

A bank uses Red Hat Enterprise Linux on System z10 to reduce their carbon footprint and address datacenter cost and capacity concerns

*The Bank of New Zealand reduces their datacenter footprint by 30%, heat output by 33%, carbon footprint by 39%, and expects a 20% ROI*

### Business Challenge

- A datacenter with 200 Sun servers was at capacity
- Bank of New Zealand needed to grow, reduce emissions and costs, become more open, and seeks to become carbon neutral by 2010

### Solution

- Consolidate 200 Sun servers into just one IBM System z10 mainframe running Red Hat Enterprise Linux

### Benefits

- Bank of New Zealand reduced power consumption by close to 40%, heat output by 33%
- Just one administrator needed for 200 virtual servers
- New environments are deployed in minutes, not days

*“Deploying IBM mainframes with Red Hat Enterprise Linux to address our carbon footprint and cost savings concerns was a very big deal, especially at the senior management level.”*

*Lyle Johnston  
Infrastructure Architect  
Bank of New Zealand*

# A Government Organization Consolidates Applications and Data to Drive Down Costs of Hardware, Software, and Management by 70%!

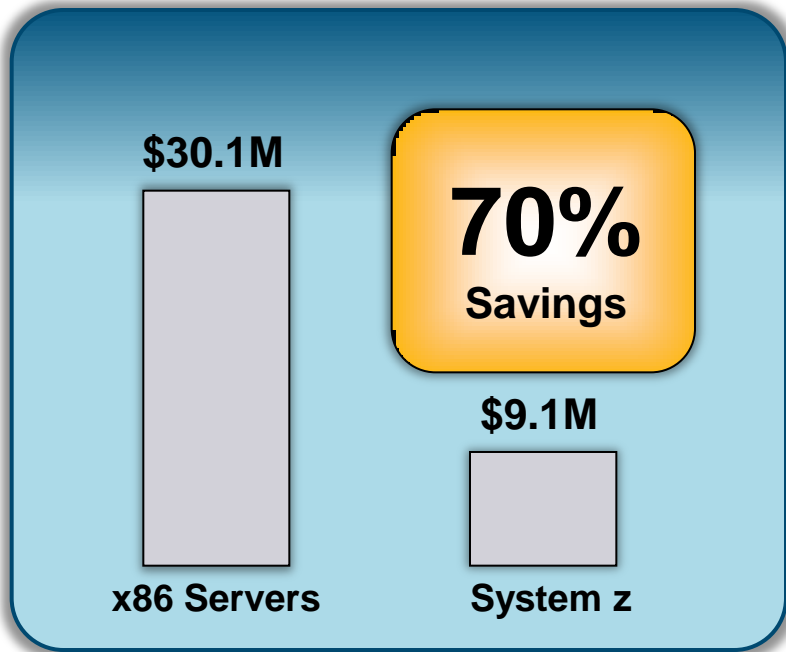

## Top three reasons for savings

- ✓ Consolidated 292 Oracle servers to one System z
- ✓ System administration costs reduced 90%
- ✓ Subscription and support licenses reduced over 95%

Customer: A regional North American government organization

### Other benefits:

- Superior resiliency and security
- Single administrator productivity
- Infrastructure simplification
- Lower energy costs

## Why Are Data Centres Consolidating to System z?

- Virtualization on IBM System z offers unique value compared to competitive scale-out solutions from Sun, HP, and others
- Superior availability and security reduces risks and improves service levels
- Extremely efficient virtualization technology lowers costs – System z achieves very high core-to-core consolidation ratios
- **Real customers, real workloads**

Customer	Distributed Cores	Ratio of Distributed to System z Cores*	Ratio of Distributed to System z cores*
Allianz	60	30 to 1	48 hour migration
Government Agency	292	58 to 1	70% cost savings
Bank of Russia	200	50 to 1	Reduces payment processing costs by 95%

\* Client results will vary based on each specific customer environment including types of workloads, utilization levels, target consolidation hardware, and other implementation requirements.



# What Are Linux Users Running on System z?

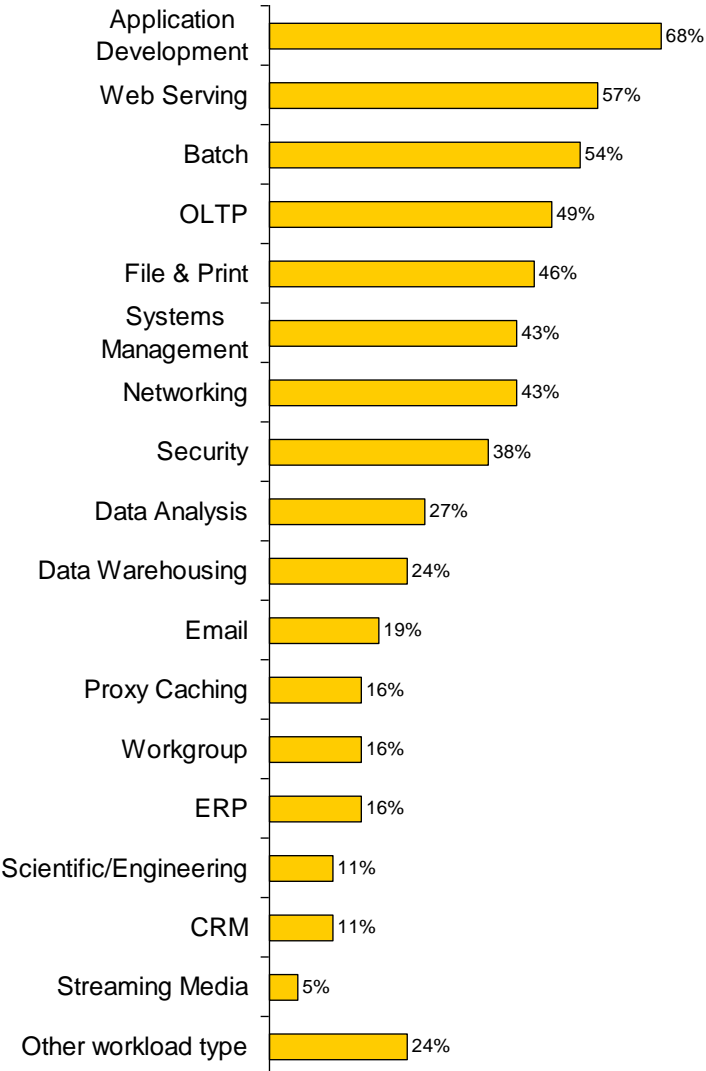

## Surveys indicate customers use:

- Web Serving
- Data Services
- Web Application Serving
- Systems Development

## Best Fit Workloads for Linux on System z:

- **Web Application Servers:** WebSphere Application Server
- **Email and collaboration:** Domino<sup>®</sup>, Web 2.0
- **Data services:** Cognos<sup>®</sup>, DB2<sup>®</sup>, Oracle, Informix<sup>®</sup>, Information Server, Information Builders WebFOCUS
- **Business critical ISV applications:** e.g., SAP
- **Development of WebSphere and Java™ applications**
- **Virtualization and security services**
- **Business connectors:** WebSphere MQSeries<sup>®</sup>, DB2 Connect™, CICS<sup>®</sup> Transaction Gateway, IMS™ Connect for Java
- **Network Infrastructure:** FTP, NFS, DNS, etc., and Communications Server and Communications Controller for Linux, CommuniGate Pro (VoIP)
- **Applications requiring top end disaster recovery model**

# IBM System z Security

## Reducing risk -- Protecting businesses

### Helping businesses:

- **Protect from INTRUSION**
  - z/OS and z/VM Integrity Statement
- **Protect DATA**
  - Built in encryption accelerators in every server
  - FIPS-140-20 Level 4 certified encryption co-processors for highly secure encryption
- **Ensure PRIVACY**
  - Access to all resources is controlled by an integrated central security manager
- **Protect VIRTUAL SERVERS**
  - The only servers with EAL5 Common Criteria Certification for partitioning
- **Respond to COMPLIANCE REGULATIONS**
  - Up to **70%** in security audit savings

Up to **52%** lower security administrative costs.

**The Gold Standard for Security**



# Multi-platform Development and Deployment on zEnterprise

*Easily extending workloads across all platforms*

## Platform dependent tools

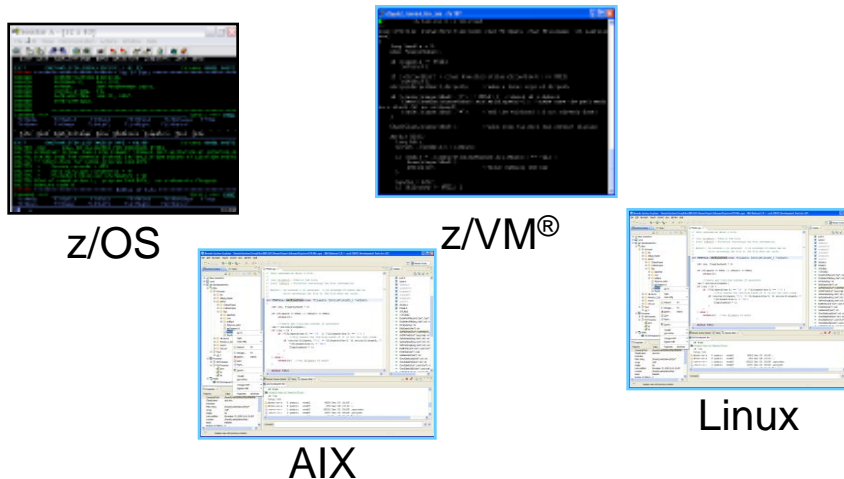

***Separate tools for each platform***

## Multi-platform tools

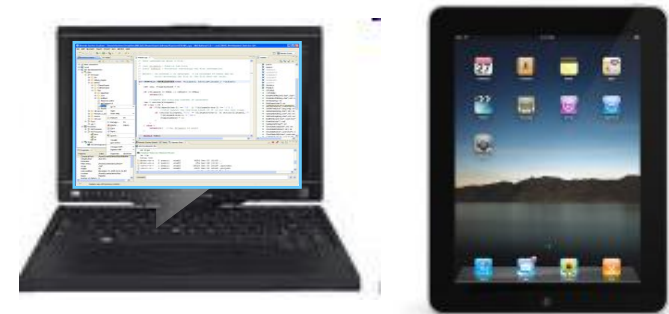

***z/OS z/VM AIX Linux***

*Eclipse-based IDE with modern GUI for  
application development  
CICS and IMS™ development  
across platforms*

- Liberate developers to rapidly prototype new applications
- Develop and test System z applications anywhere, anytime
- Free up mainframe development MIPS for production capacity
- Eliminate costly delays by reducing dependencies on operations staff

# IBM System z IT Optimization and Consolidation

*Helping Clients Save Money, Reduce Complexity, Improve Service*

- Consolidate 3x or more\* servers per core than virtualized x86 offerings: spend less on software, energy, floor space and disaster recovery
- Manage more server images with fewer people
- Exploit extensive z/VM facilities for life cycle management: provisioning, automation, monitoring, workload management, capacity planning, security, charge back, patching, backup, recovery, more...
- Deploy new servers and applications faster: in seconds instead of hours or days

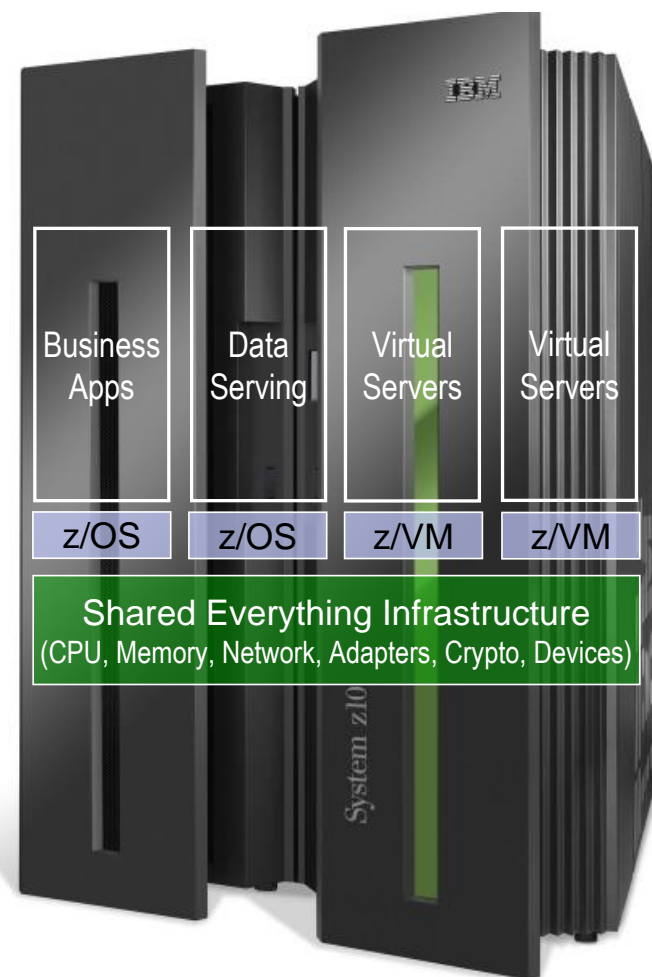

A Fully virtualized infrastructure enables optimization to maximize efficiency

**Consolidate the workloads of thousands of distributed servers in a single system**

- Up to **90%** Reduction in energy consumption
- Up to **95%** Reduction in Floor Space
- Up to **98%** Reduction in SW License costs

IBM

zEnterprise

# Thank you

