

WebSphere software



WebSphere Business Integration

Malcolm Smeal

IBM Software Group

Introduction

- We're living in a world of unprecedented connectivity
 - ▶ Call from a cell phone anywhere in the world
 - ▶ Search the web to find information from billions of potential sites
 - ▶ Shop from your PDA while you're on the move
- The commercial exploitation of this new world used to be called "e-business"...
- "Today, e-business is just business - real business... and the winners understand that this next phase of e-business is going to be all about two things: Integration and Infrastructure"
 - ▶ Lou Gerstner, Chairman and CEO IBM
- Integration - Enabling people and systems to work together
- Infrastructure - Supporting operations under the pressures of the interconnected world



Business Integration

- Enables disparate people and computing resources inside and outside the enterprise to work together to support the company's business strategy.
- Breaks down traditional barriers between applications, internal departments and external organisations, leading to greater efficiency, improved business control and enhanced flexibility.



Why is integration so important to business ?

“Up to \$4.4 Billion was lost in e-commerce revenues in 1999 due to inadequate infrastructure that led to poor site and service performance.”

—Source: Zona Research

"Resolution Strategies require solutions that can link the electronic world to the paper world. The key components of such solutions are strong process management or workflow; business rule creation, change and simulation; information movement, translation, and packaging across a variety of media."

—David Yochelson

WebSphere software

Meta Group

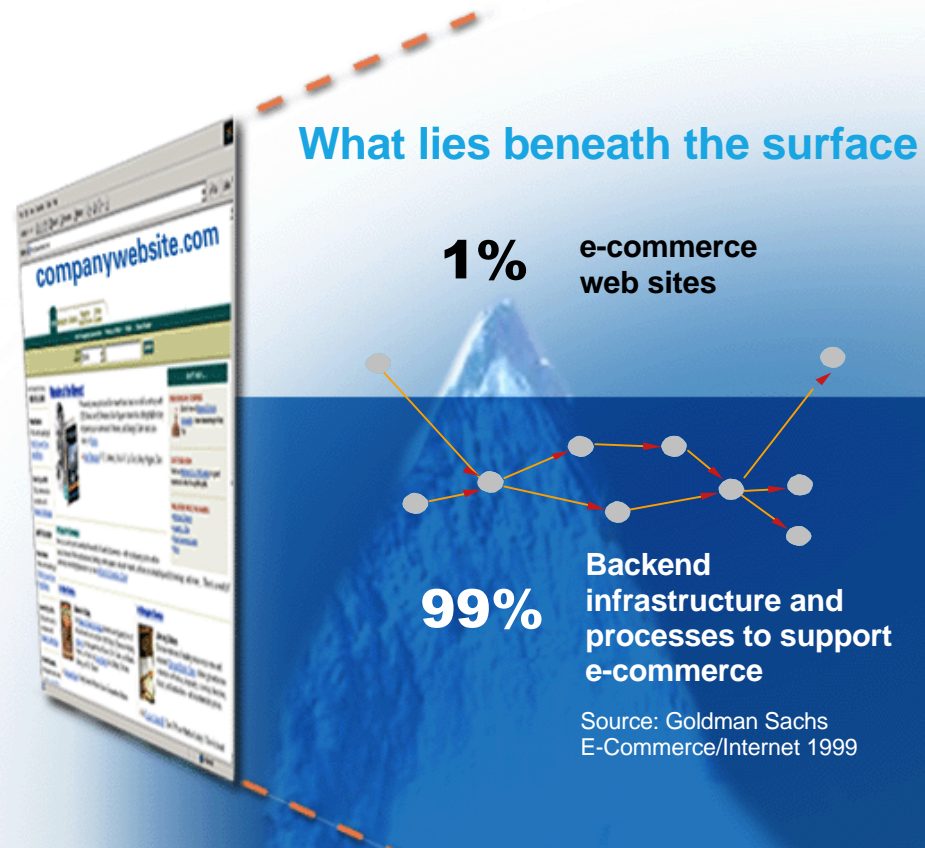

Unifying your information for a single "view of truth"

Information Connectivity

- Create a single view of information, and then make it available where and when it's needed
 - ▶ Standardize and route claim, referral and enrollment data submitted in accordance with the HIPPA federal regulations - enabling business engineers and application developers to view blueprints/models to update specifications from a unified location
- Ensure there's only one version of key business information that every part of the business can work on
- "... the functionality of WebSphere will help us best achieve full integration within our heterogeneous platform environment of multiple systems and applications, therefore best enabling multiple areas of our business."
 - David Marckel, manager of Enterprise Document Management Systems, BCBST

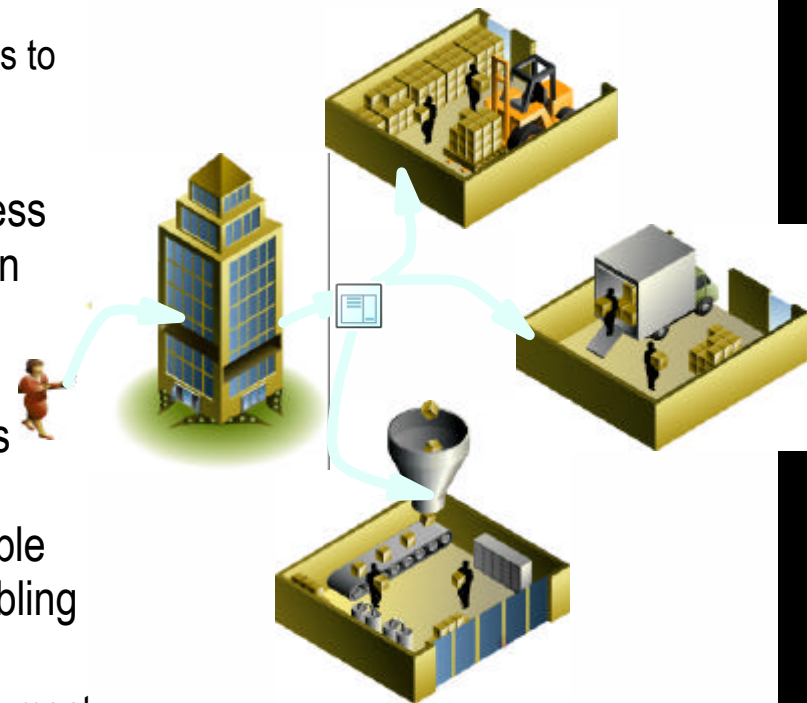

Optimizing business processes through automation

Process Integration

- Coordinate activities that span multiple systems and people to match the end-to-end business process
 - ▶ Integrate disparate internal systems and processes such as claims processing, new business acquisition, customer services and image processing into a paperless process
- Automate and improve business processes
- "In a very short space of time, we were able to implement the Criterion paperless office strategy with workflow and content management. I have never seen such a compelling ROI, and we look forward with great confidence to proposing this set to other clients."
 - Richard Higgs, Managing Director Strategic Thought (BP for Criterion process integration)

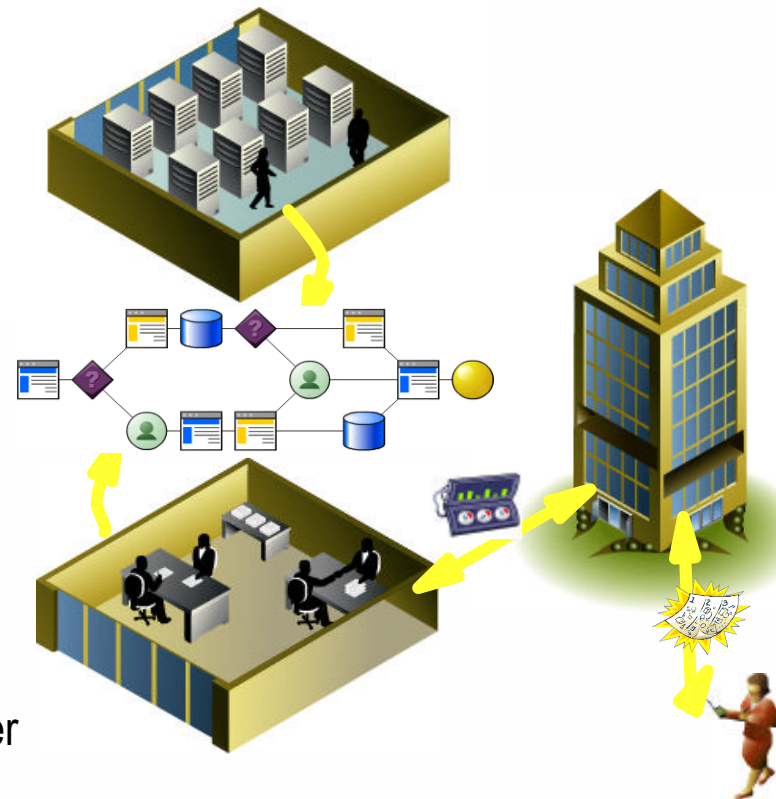

WebSphere software



e-Business drives Business Integration

Traditional Business

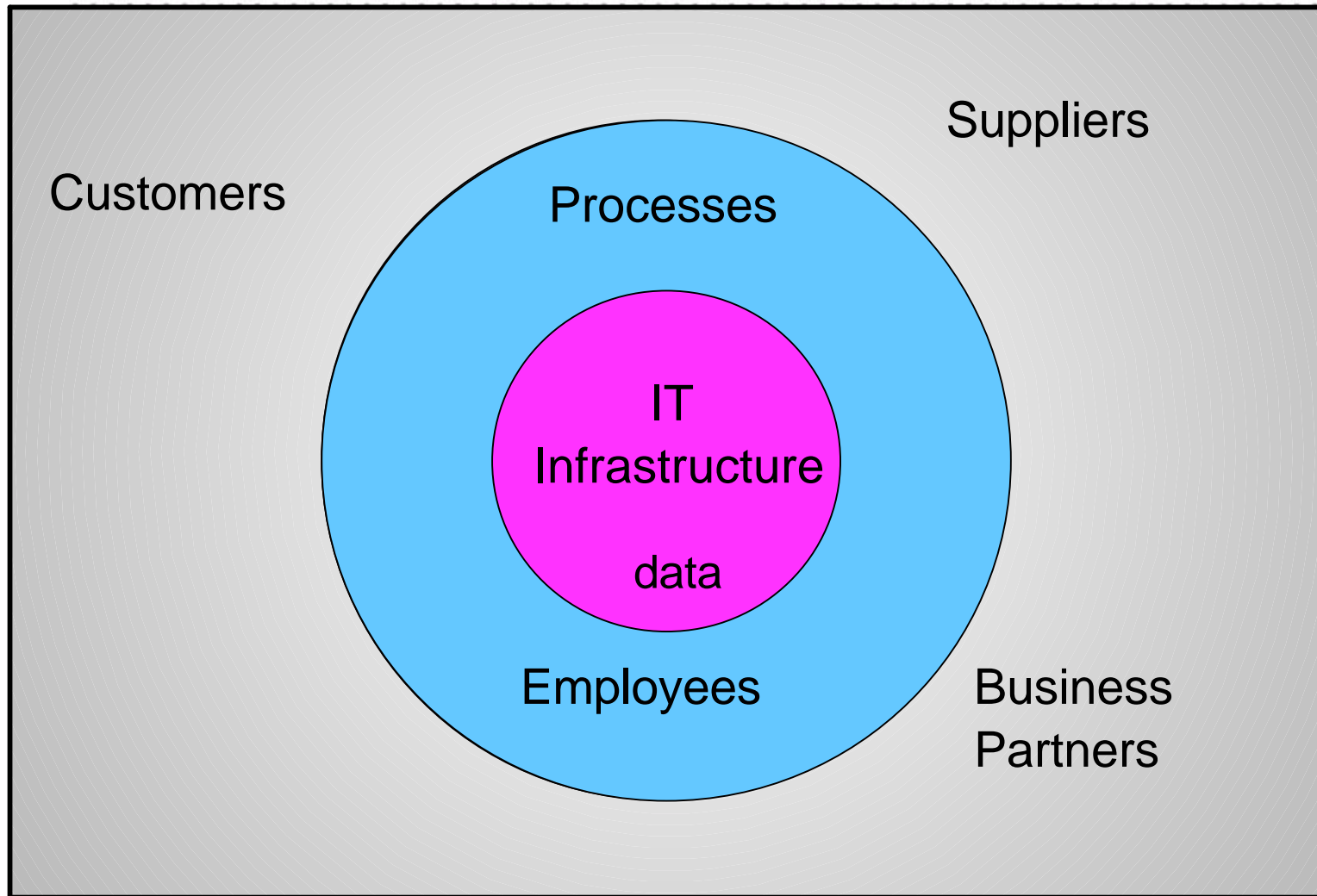

... it turns the model inside-out!

e-Business

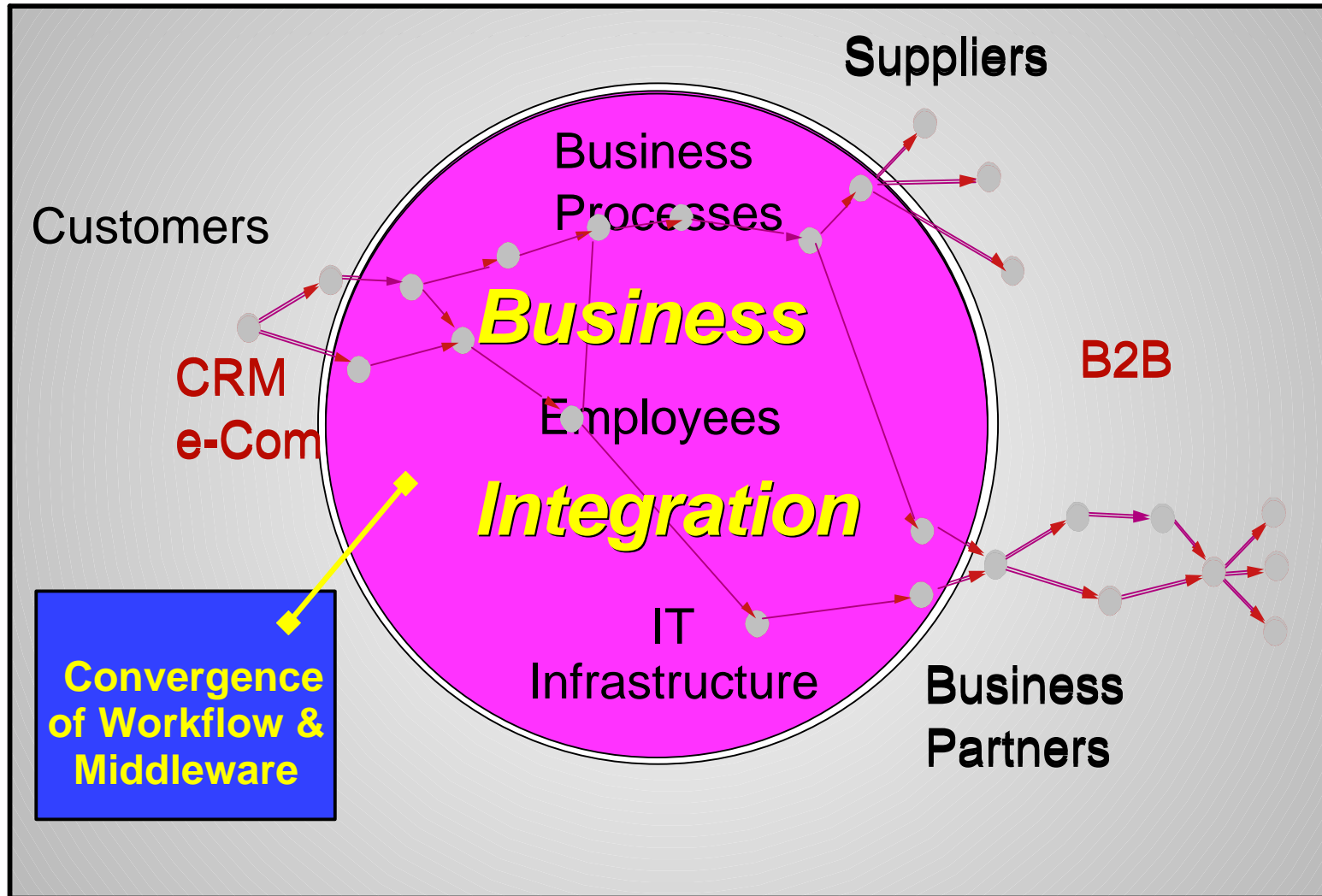

So business Integration is about unlocking the value of your assets

...in the form of

- ▶ Information
- ▶ Processes
- ▶ Applications
- ▶ People

...by

- ▶ Distributing information throughout the business so it can be used where and when it's needed
- ▶ Aligning the processes performed by people and systems with the needs of the business
- ▶ Creating flexible applications to meet changing business requirements by harnessing existing applications as reusable services



Distributing information throughout the business

WebSphere software



Business Integration - the technical challenges

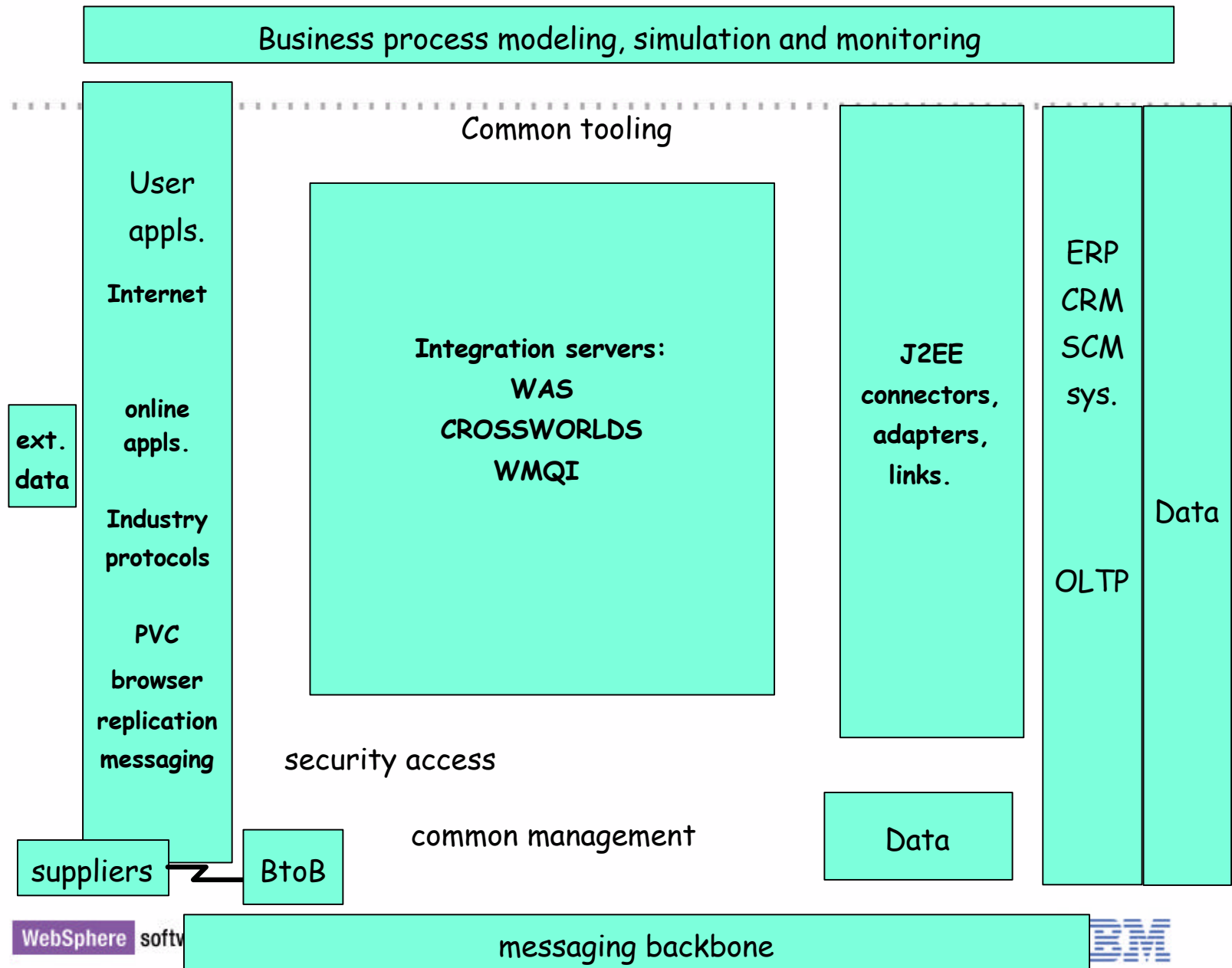

Business Integration WEBSPHERE Application Server

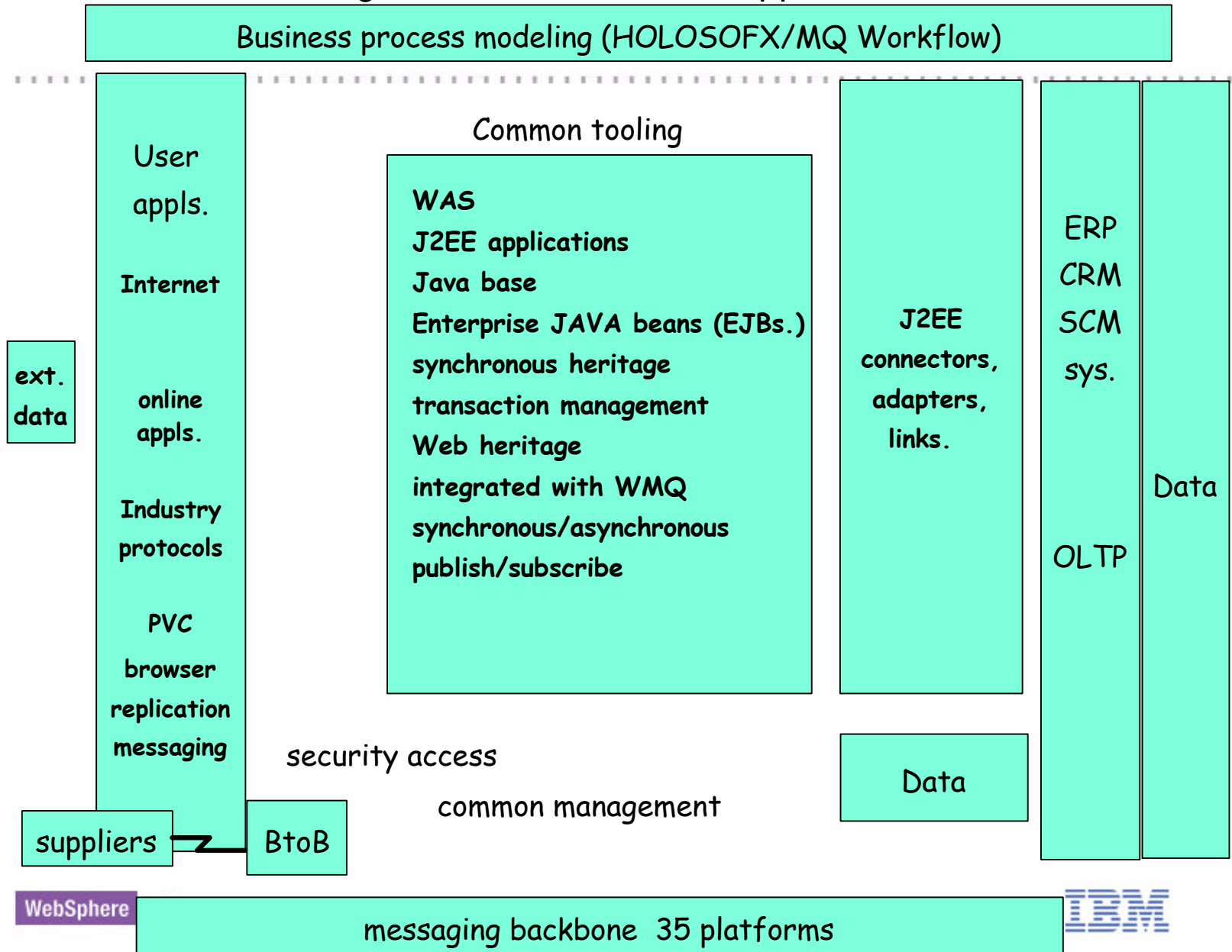

Business Integration - CROSSWORLDS

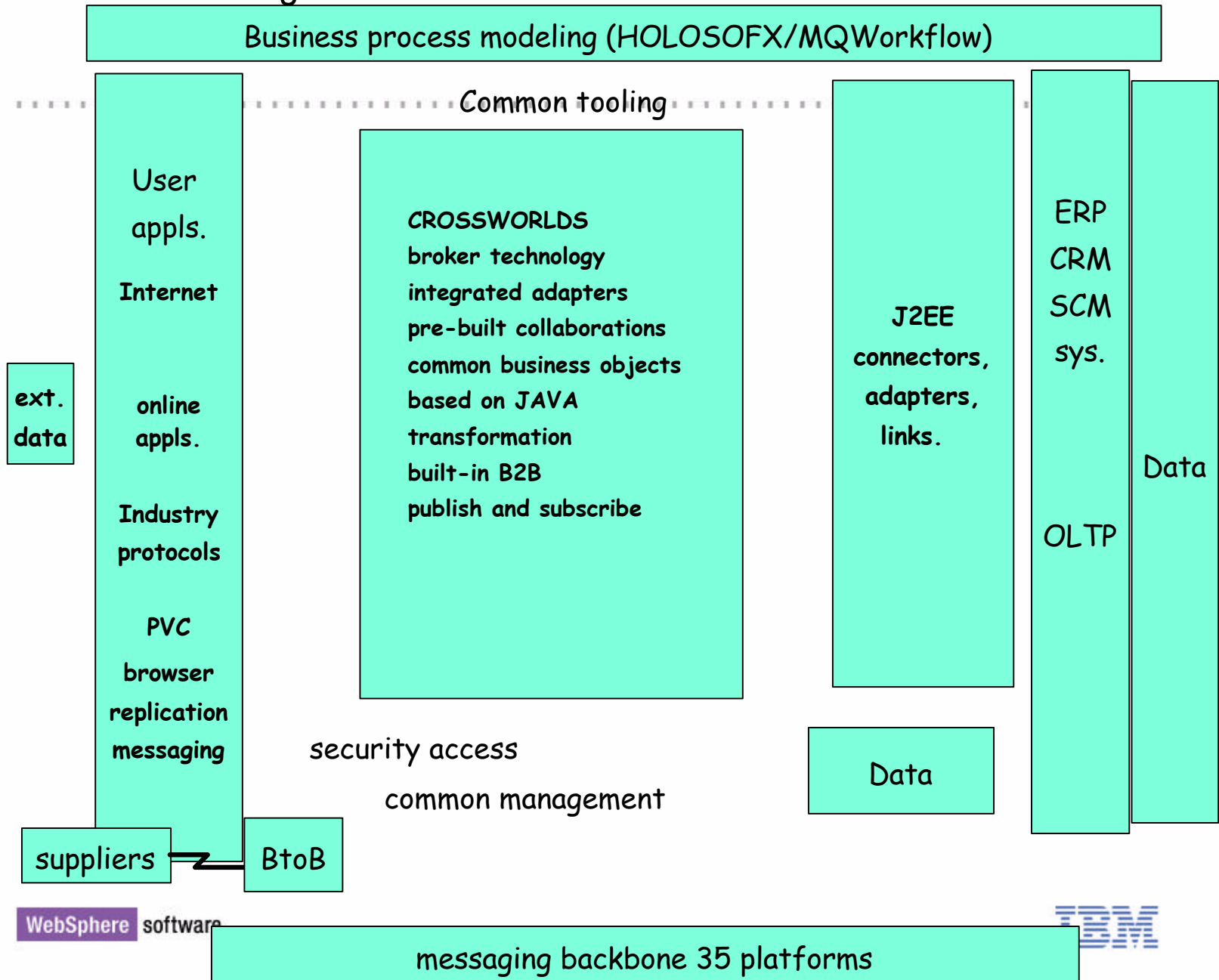

Business Integration with WEBSPHERE MQ integrator

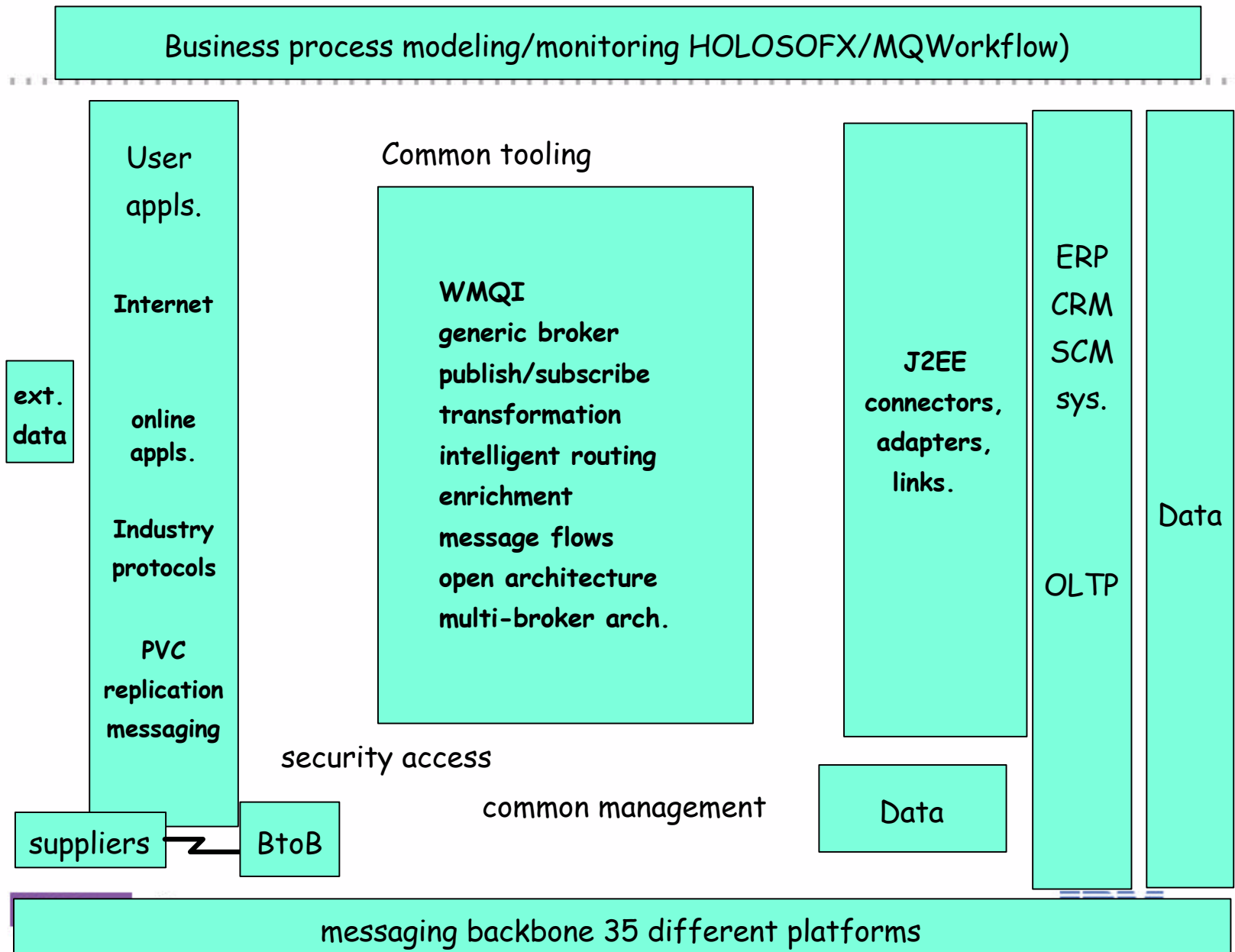

WebSphere MQ : Any-to-Any Simple Enterprise Connectivity

- Shields complexities of infrastructure from developers
- Consistent API across 40+ platforms
- 3 out of 4 MOM customers use MQSeries
- Easy to use
- Assured delivery - even across the Internet
- Asynchronous
- Highly scalable
- Transactional
-

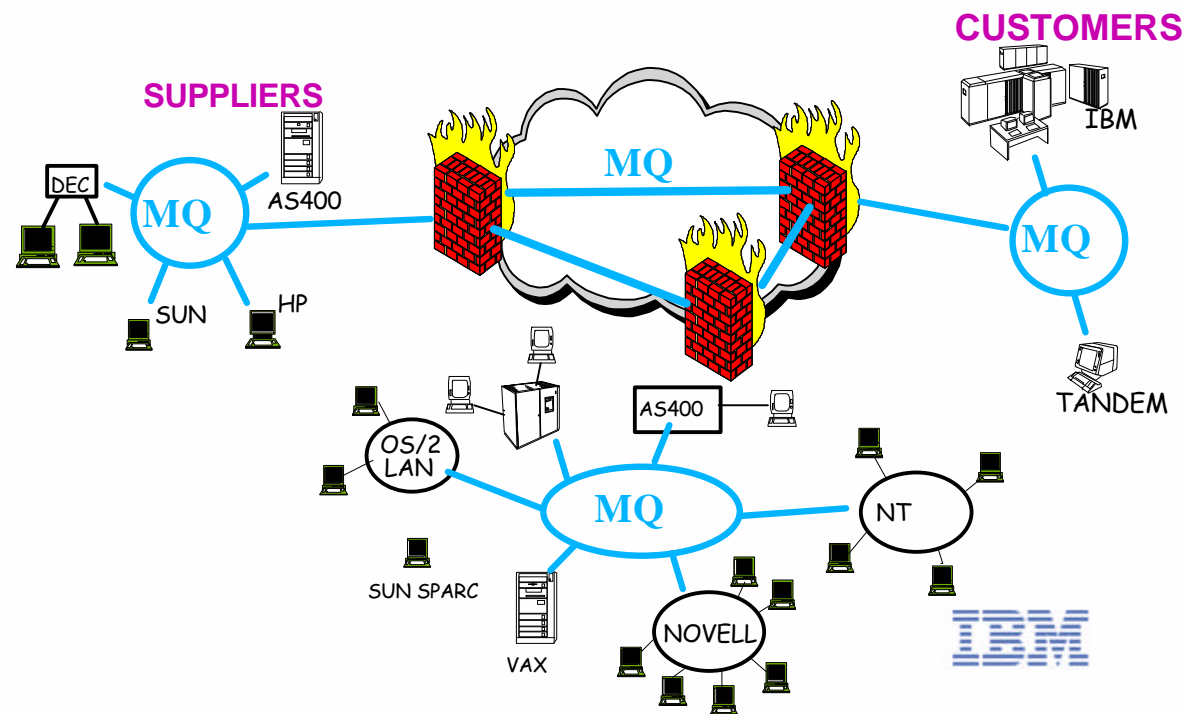

WebSphere MQ Integrator : Message Brokering

Making sense of information

- Transforms information flowing between resources
- Routes information to one or more resources
- Allow resources to be selective about the information they receive
- Context and content of enterprise information understood
- Repository of rules about enterprise information

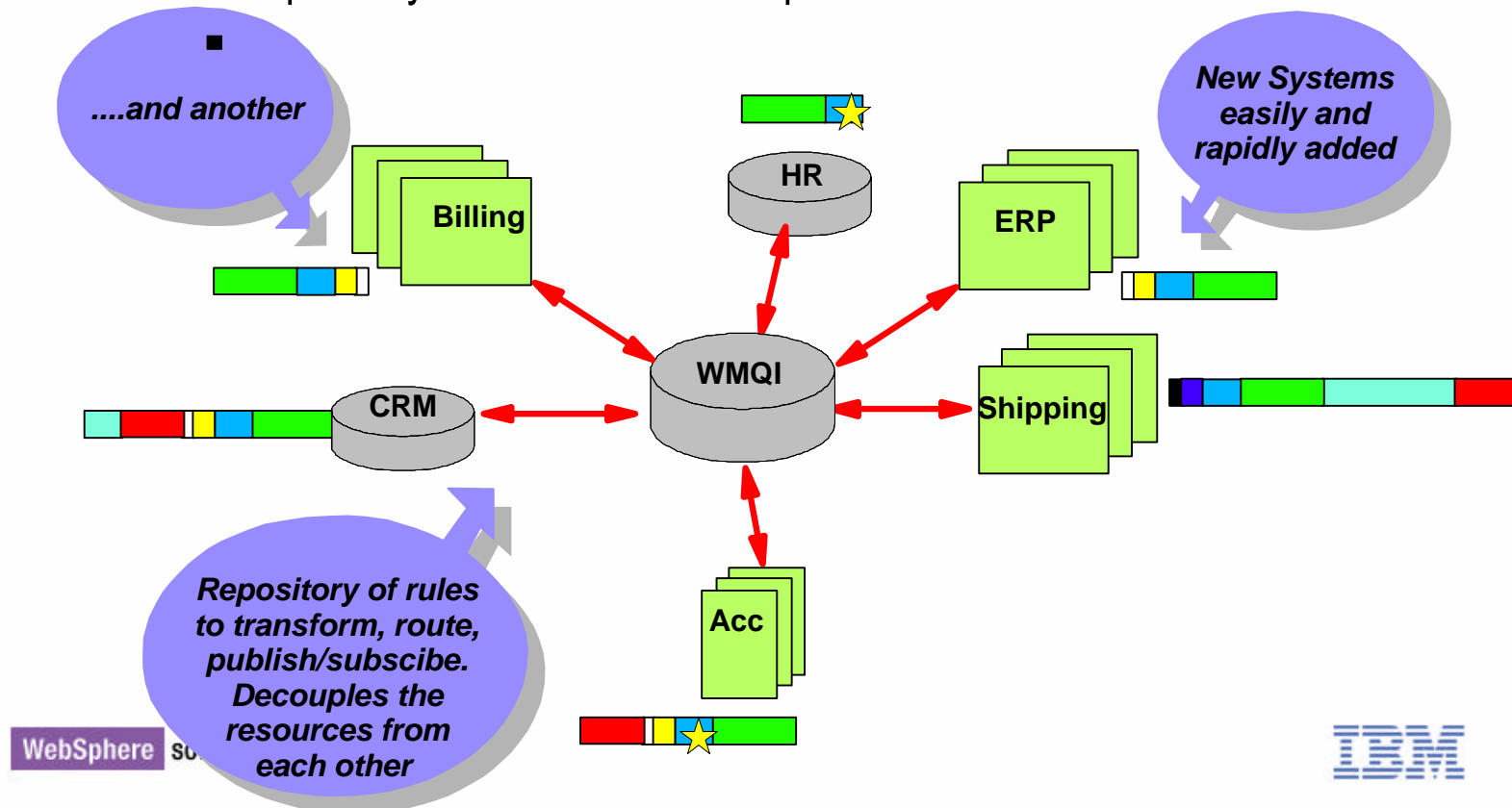

Publish and Subscribe - puts you in control of events

Benefit:

- ✓ Provides you with the information you want, when you want it.
- ✓ Allows applications/ users to be specific about the information they need (subject level or content)
- ✓ Enables agility by ability to quickly specify in real time changes of subject and content interest
- ✓ Reduces unwanted information on the network or through your door

Uses (limitless)

- ✓ "Tell me when a pressure valve "A" on a remote pipe line in the desert reaches a particular level and then automatically open "B" and "C"
 - ✓ "Alert me if stock prices for company X reaches \$XXX per share"
 - ✓ "Let me have all results for a sporting event between for the next three hours"
 - ✓ "Shut down all appliances if the electricity usage exceeds X units between hours of 2am and 6am."
- ★ 1000s of concurrent clients
 - ★ Support for :
 - ★ MQSeries
 - ★ MQe
 - ★ SCADA
 - ★ IP

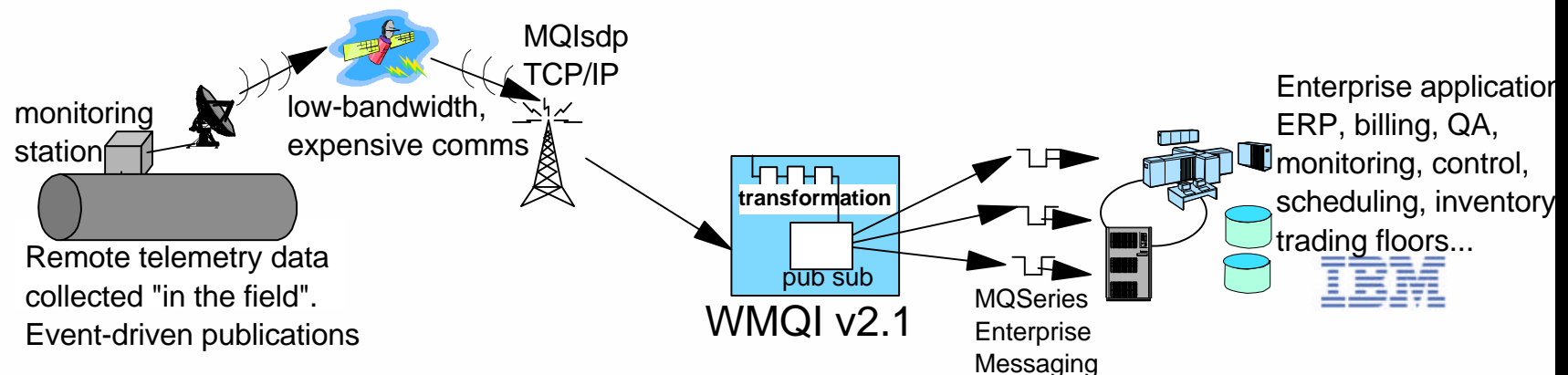

Distributing information inside and outside the enterprise

Extending to a Mobile Workforce

MQSeries Everyplace for Multiplatforms, Version 1 Release 2 Brings a reliable connection into a hostile world

- **Extend the messaging network**
 - ▶ **Empower the mobile workforce**
 - Secure access to business data
 - Get connectivity to the messaging backbone
 - Enable transactions on the move
 - Exploit the new devices for business
 - Palm, Pocket PC, ...
 - Connect to the source of new messages
 - Create the demand for more infrastructure
 - ▶ MQSeries Everyplace input node in WebSphere MQ Integrator

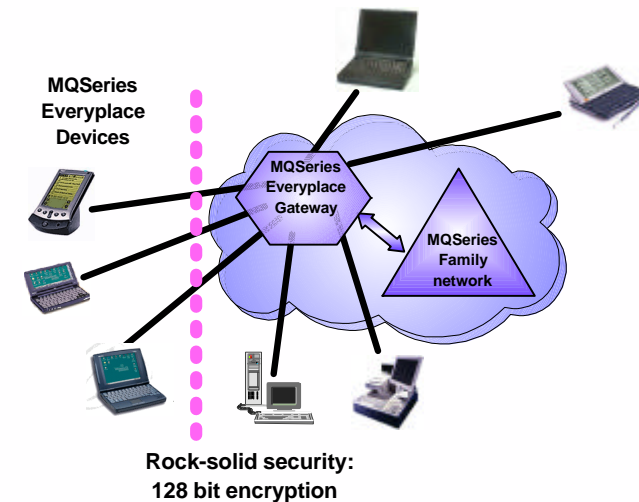

Why IBM for Business Integration ?

- ★ **eAI Journal MQSI gets gold award for "Solution of the Year 2001" and MQSeries Everyplace with a silver award for "Product of the year 2001"**
- ★ **Customer Success**
 - ✓ **10,000** customer sites using MQSeries !!!!
 - ✓ **1,300** customers using WMQI
 - ✓ **1,000** (nearly) using MQSeries Workflow
- ★ **Four out of five customers who buy interapplication messaging systems buy MQSeries (Wintergreen)**
- ★ **MQSeries won 'Best Java Messaging Tool' in the highly prestigious Java Developers Journal Readers' Choice Awards**
- ★ **9 out of the top 10 Fortune 100 customers rely on MQSI everyday.**
- ★ **More than 550 independent vendors offer MQSeries-based services and products**
- ★ **More than 3000 people, representing more than 1000 different companies worldwide have passed an MQSeries Family certification test.**





Aligning your processes with the needs of the business

WebSphere software



MQSeries Workflow and HOLOSOFX - Integrates and Manages your Business Processes

- Define the business process in HOLOSOFX
 - ▶ This is a key input for an IT requirements document
- Simulate and cost of each manual and automatic step
- Run the process under the control of MQWorkflow and record status
- Monitor the events in real time with HOLOSOFX and WORKFLOW
- Monitor costs
- Business processes are constantly evolving

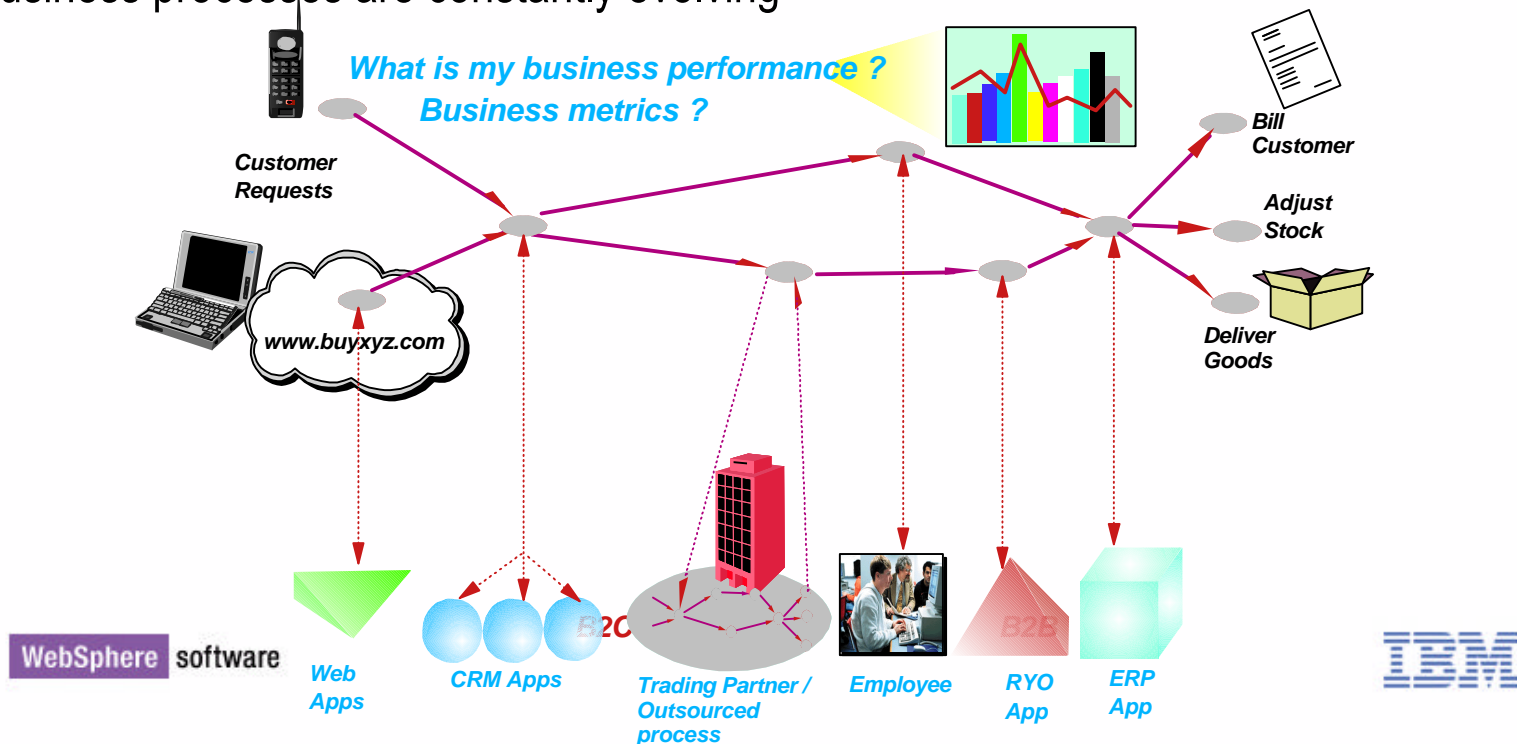

WebSphere Partner Agreement Manager-Business to Business Integration

- 'Public Process' agreed by consensus between two or more parties
- defines business protocols for BtoB environments
- View, EDI and full BtoB options
- Companies still maintain privacy of their own processes
- 'Process Firewall'

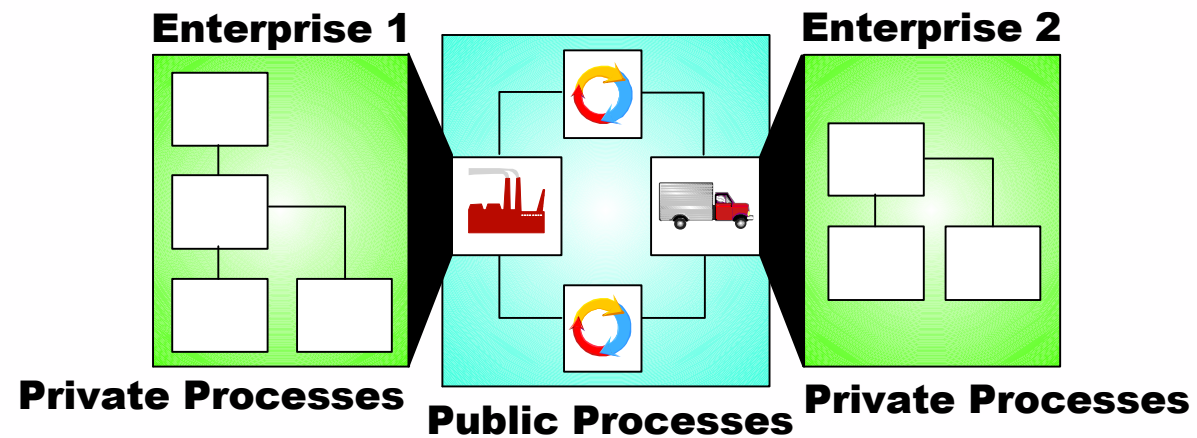

Widening your Horizons beyond Traditional BtoB

- Need to increase global reach and market share
- Who can provide the 'best' service to me
- How do I contact another company and find out about their service
- How do I use an available service ?



Any one out there ?



Why Web Services?

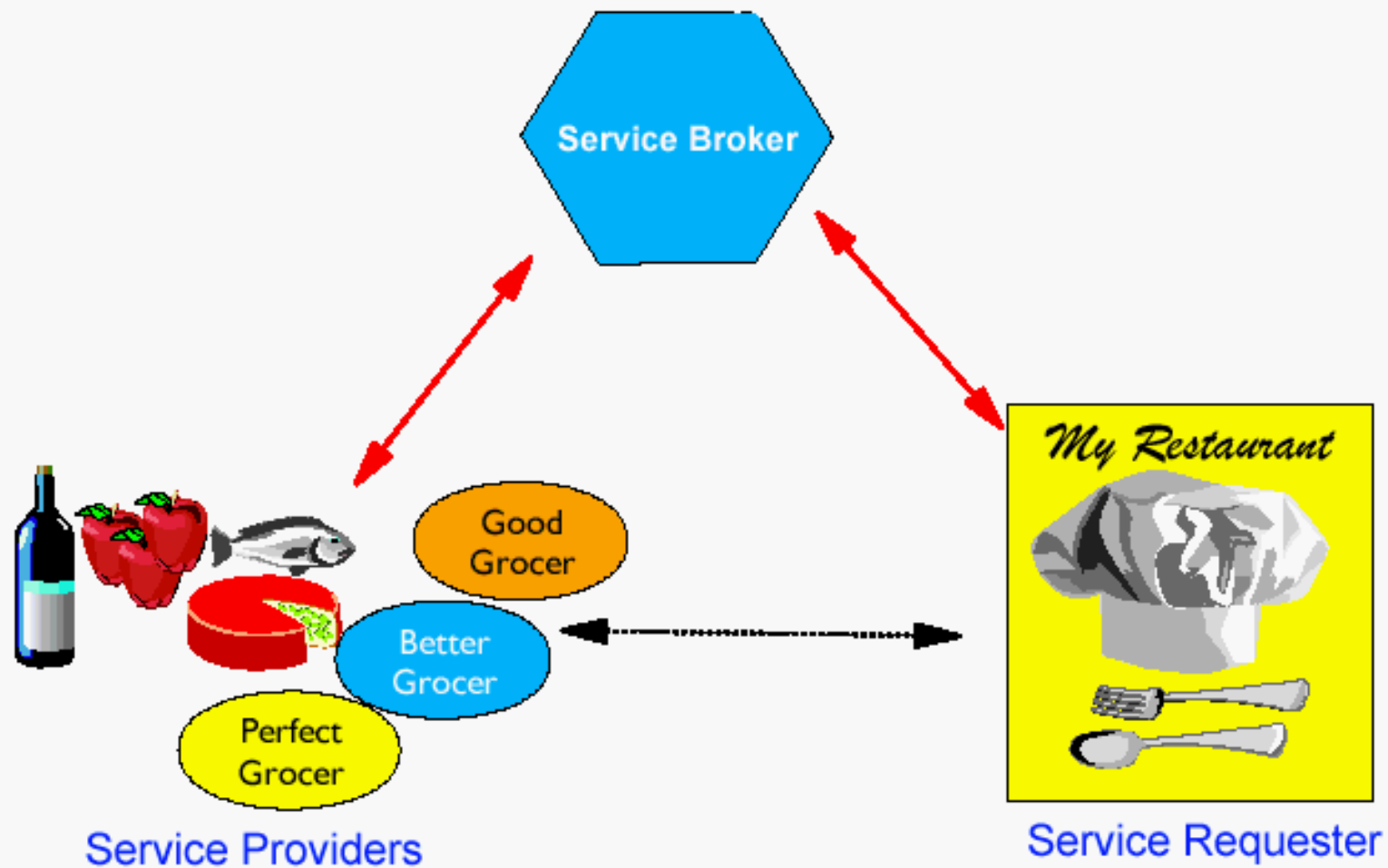

WebSphere software



IBM Web Services - extending and integrating your services WW

- Make your services and processes available WW
 - ▶ Increase your business' WW presence
 - ▶ Increase visibility of internal services
- Discover other WW processes (even at run time) and use them
 - ▶ Bring the best to your customers for competitive differential
- ...It standardizes integration, makes it dynamic
- Automatic and anonymous application integration
 - ▶ Between different businesses
 - ▶ Within the same business

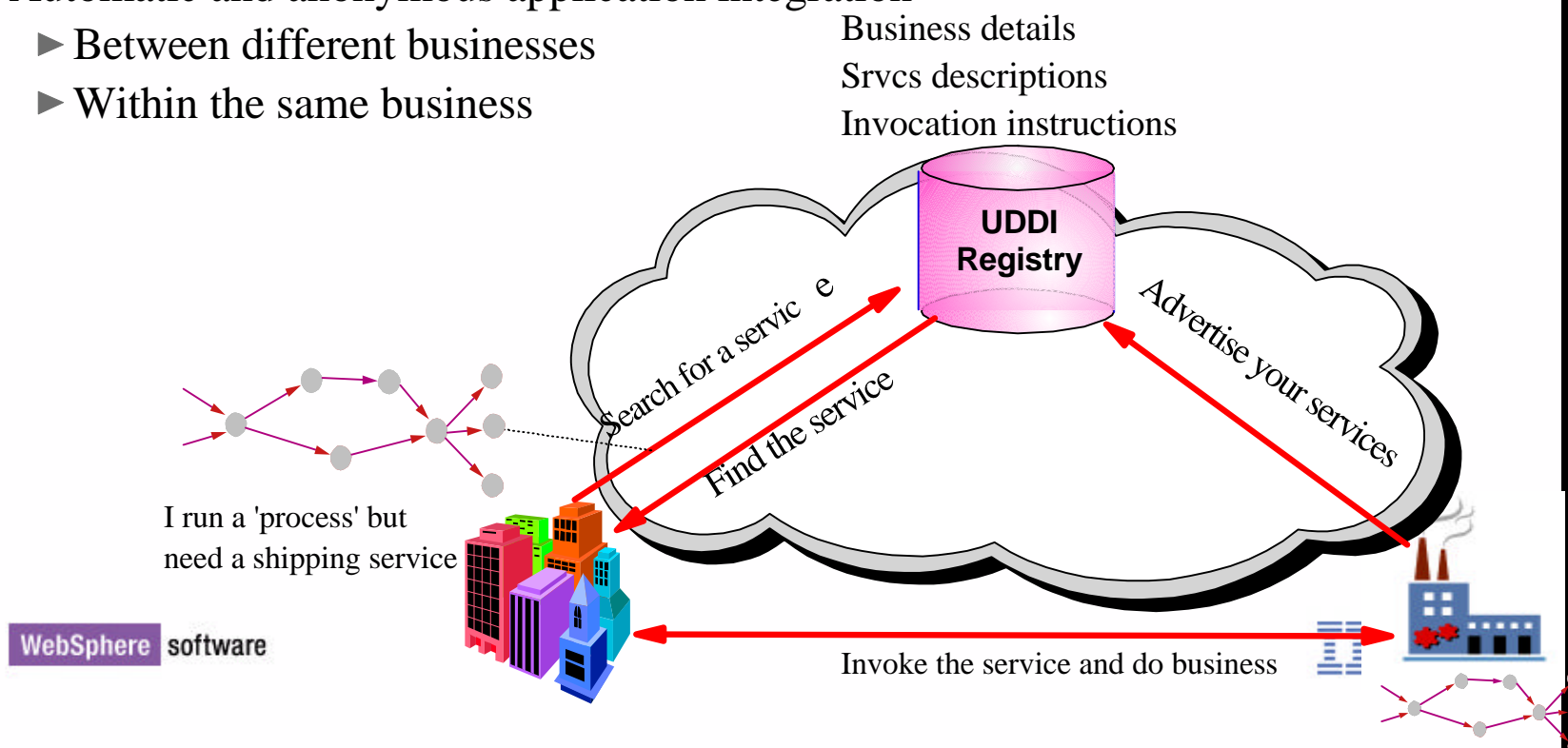



Creating Flexible Applications

WebSphere software



WebSphere Studio Workbench - One set of tools for Business and IT

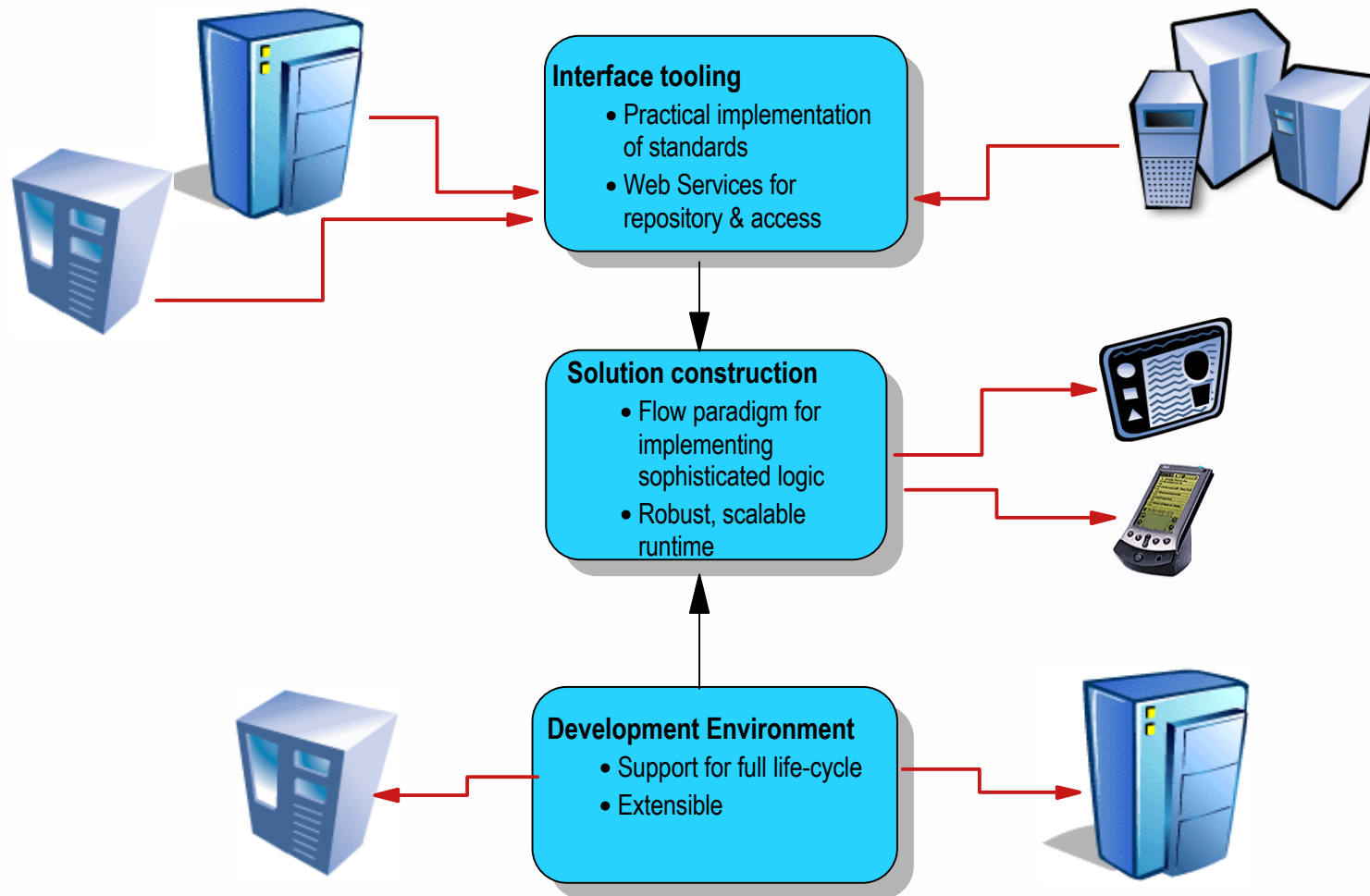

A consistent view of enterprise resources

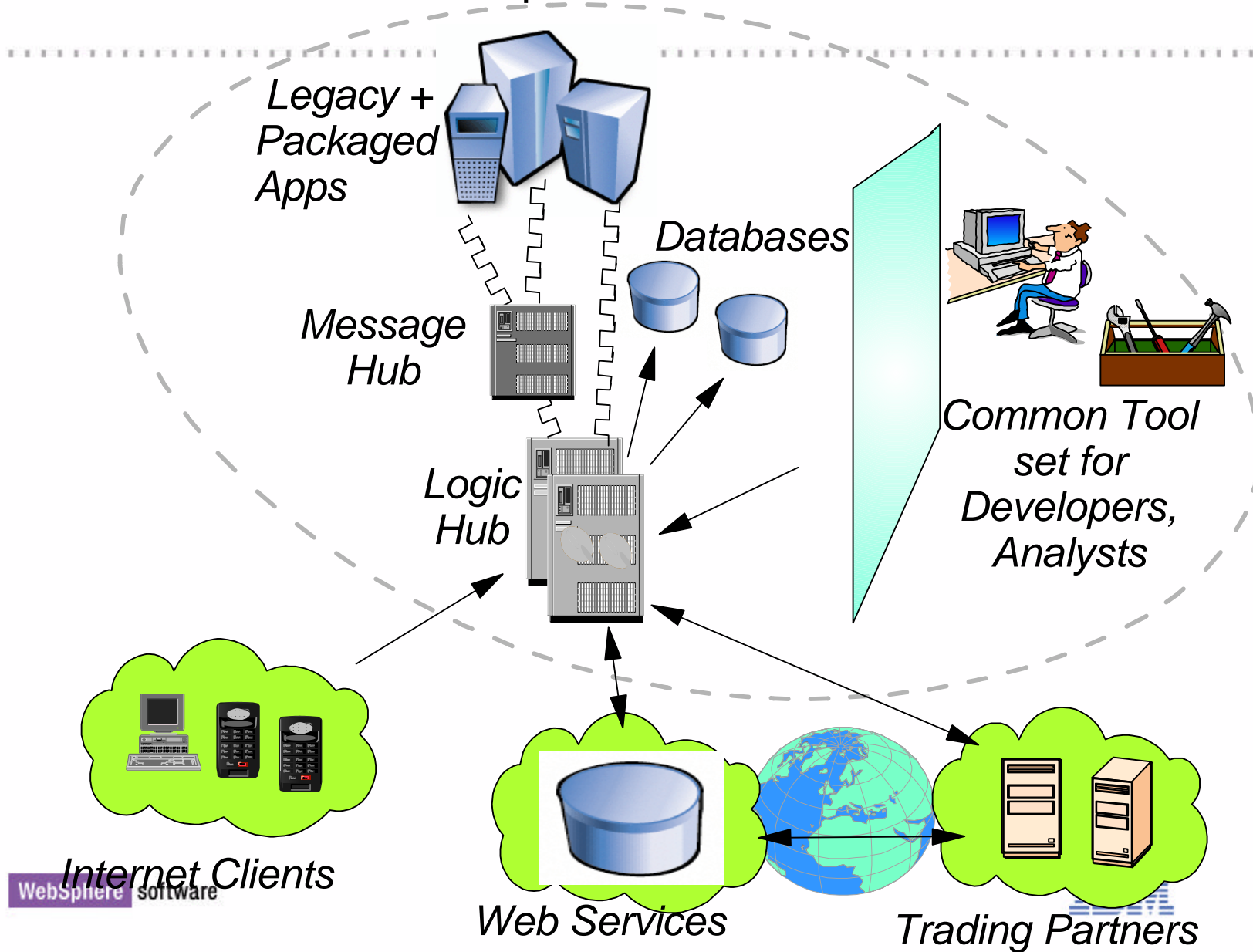

Wouldn't it be good if you...

- ...didn't need to source connectors/adapters for packaged app's?
 - ▶ Web Services standards are defining an open way for app vendors to expose integration interfaces
- ...could find resources easily?
 - ▶ Web Services implementations are providing infrastructure to describe and discover services
- ...could work from IT to business levels and across functions with one set of metadata and process information?
 - ▶ Eclipse provides an extensible tooling framework, common model for metadata and process
 - ▶ Unified programming model describes low-level app logic up to high-level business flows in a common way
- ...could create new business logic from existing services?
 - ▶ Web Services standards are evolving to provide descriptions of the way that services are coordinated to deliver business function
- ...could modify and extend existing business logic within app's?
 - ▶ Applications built on the web services standards will allow functions to be replaced, shared and augmented

WebSphere Differentiators

- Simple, portable programming APIs
 - ▶ Native for major languages across 35+ platforms, plus Java, CICS, IMS, COM, etc.
 - ▶ Encapsulate configuration and data formatting
- Multiple delivery options
 - ▶ Guaranteed once-only
 - ▶ High performance in-memory
 - ▶ Confirmation of delivery
 - ▶ Distribution lists
 - ▶ Publish & subscribe
 - ▶ Rules-driven routing
- Exploit platform-specific strengths
 - ▶ Availability & scalability
- Scalable
 - ▶ From Palm to Windows to z/OS
- Flow control for people and applications

Single Vendor Advantages

- Product synergies
 - ▶ Common design points
 - Documentation
 - ▶ Common style and format
 - Education
 - ▶ Consistent approach
 - Support
 - ▶ Single vendor responsibility
 - Conferences
 - ▶ One event covers multiple products - PartnerWorld, Technical Conferences
 - Purchasing
 - ▶ One client team / software account manager
-
- Bottom line - lower Total Cost of Ownership (TCO)

The WebSphere Software Platform has you covered

Delivering an End-to-End Business Integration Portfolio

