

Gentran:Control[®] for zSeries

User's Guide

Release 6.4

Sterling Commerce
An IBM Company

Sterling Commerce (Mid America), Inc.
4600 Lakehurst Court Dublin, OH 43016-2000 * 614/793-4000
© Copyright 1988 – 2005—Sterling Commerce, Inc.

December 2005

Gentran:Control for zSeries
© Copyright 1988 – 2005
Sterling Commerce, Inc.
ALL RIGHTS RESERVED

Sterling Commerce Software

Trade Secret Notice

THE GENTRAN:CONTROL AND GENTRAN:BASIC FOR ZSERIES SOFTWARE (“STERLING COMMERCE SOFTWARE”) IS THE CONFIDENTIAL AND TRADE SECRET PROPERTY OF STERLING COMMERCE, INC., ITS AFFILIATED COMPANIES OR ITS OR THEIR LICENSORS, AND IS PROVIDED UNDER THE TERMS OF A LICENSE AGREEMENT. NO DUPLICATION OR DISCLOSURE WITHOUT PRIOR WRITTEN PERMISSION. RESTRICTED RIGHTS.

This documentation, the Sterling Commerce Software it describes, and the information and know-how they contain constitute the proprietary, confidential and valuable trade secret information of Sterling Commerce, Inc., its affiliated companies or its or their licensors, and may not be used for any unauthorized purpose, or disclosed to others without the prior written permission of the applicable Sterling Commerce entity. This documentation and the Sterling Commerce Software that it describes have been provided pursuant to a license agreement that contains prohibitions against and/or restrictions on their copying, modification and use. Duplication, in whole or in part, if and when permitted, shall bear this notice and the Sterling Commerce, Inc. copyright notice.

As and when provided to any governmental entity, government contractor or subcontractor subject to the FARs, this documentation is provided with RESTRICTED RIGHTS under Title 48 CFR 52.227-19. Further, as and when provided to any governmental entity, government contractor or subcontractor subject to DFARs, this documentation and the Sterling Commerce Software it describes are provided pursuant to the customary Sterling Commerce license, as described in Title 48 CFR 227-7202 with respect to commercial software and commercial software documentation.

These terms of use shall be governed by the laws of the State of Ohio, USA, without regard to its conflict of laws provisions. If you are accessing the Sterling Commerce Software under an executed agreement, then nothing in these terms and conditions supersedes or modifies the executed agreement.

Product names mentioned herein may be trademarks and/or registered trademarks of their respective companies. Gentran, Gentran:Basic, Gentran:Control, Gentran:Plus, Gentran:Realtime, Gentran:Structure, and Gentran:Viewpoint are registered trademarks of Sterling Commerce, Inc.

Third Party Software:

Portions of the Sterling Commerce Software may include products, or may be distributed on the same storage media with products, (“Third Party Software”) offered by third parties (“Third Party Licensors”).

Warranty Disclaimer

This documentation and the Sterling Commerce Software which it describes are licensed either "AS IS" or with a limited warranty, as set forth in the Sterling Commerce license agreement. Other than any limited warranties provided, NO OTHER WARRANTY IS EXPRESSED AND NONE SHALL BE IMPLIED, INCLUDING THE WARRANTIES OF MERCHANTABILITY AND FITNESS FOR USE OR FOR A PARTICULAR PURPOSE. The applicable Sterling Commerce entity reserves the right to revise this publication from time to time and to make changes in the content hereof without the obligation to notify any person or entity of such revisions or changes.

The Third Party Software is provided 'AS IS' WITHOUT ANY WARRANTY AND ANY EXPRESSED OR IMPLIED WARRANTIES, INCLUDING BUT NOT LIMITED TO, THE IMPLIED WARRANTIES OF MERCHANTABILITY, AND FITNESS FOR A PARTICULAR PURPOSE ARE DISCLAIMED. FURTHER, IF YOU ARE LOCATED OR ACCESSING THIS SOFTWARE IN THE UNITED STATES, ANY EXPRESS OR IMPLIED WARRANTY REGARDING TITLE OR NON-INFRINGEMENT ARE DISCLAIMED.

Table of Contents

Chapter 1 Getting Started

Overview	1-1
Features.....	1-2
System Overview.....	1-4
System Operation	1-7
System Architecture	1-26
System Operation Examples.....	1-28

Chapter 2 Tutorial

Overview	2-1
Tutorial Screen Inconsistencies.....	2-2
Logging on to Gentran:Control	2-3
Updating Security	2-4
Navigating Gentran:Control Screens.....	2-8
Creating a Queue File.....	2-19

Chapter 3 Screens

Overview	3-1
Jump Codes	3-2
Control Main Menu	EDIM300..... 3-6
System Options Maintenance Screen	EDIM301..... 3-8
Queue Directory Screen	EDIM302..... 3-12
Queue Options Maintenance Screen	EDIM303..... 3-16
Online Log Display Screen	EDIM304..... 3-25
Extended Queue Options Maintenance Screen	EDIM305..... 3-31
Queue Options Debug Detail Screen.....	EDIM306..... 3-34
Queue Options Data Display Screen	EDIM307..... 3-44
Online Log Detailed Display Screen.....	EDIM308..... 3-46
Separator Main Menu	EDIM934..... 3-50
Separator Systems Options Maintenance Screen	EDIM935..... 3-52
Priority Options Directory Screen.....	EDIM936..... 3-59
Priority Options Maintenance Screen.....	EDIM937..... 3-62
Separator Monitor Screen.....	EDIM938..... 3-66

Chapter 4 Program Descriptions

Overview	4-1
Utility Control Card Format	4-3
Multi-Queue Read Subroutine.....	EDIRCMR..... 4-4
Multi-Queue Write Subroutine.....	EDIRCMW..... 4-5
Queue File Maintenance.....	EDIEQMT..... 4-6
Queue Read	EDIRQRD..... 4-9

Table of Contents

Batch Wait Utility.....	EDIWAITD	4-14
Asynchronous Program	EDIRASYN.....	4-15
System Status Toggle Program	EDIETOGL	4-18
Queue Write	EDIRQWR	4-19
Remote Single-queue Read Subroutine.....	EDIERSR	4-24
Sample Queue Read	EDIESQR	4-30
Remote Single-queue Write Subroutine.....	EDIERSW	4-31
Sample Queue Write.....	EDIESQW	4-36
Online Output Gateway.....	EDIEOOG	
.....	EDIEOQW	
.....	EDIROQW	4-37
Online Input Gateway.....	EDIEOIG	
.....	EDIEOQR	
.....	EDIROQR	4-46
Exception Exit	EDIEXIT1	4-53
Online Error User Exit.....	EDIEXIT2	4-56
Online Batch Initiator	EDIEOBI	4-59
Online Scanner/Initiator	EDIEOSI	4-60
Automatic System Start-up.....	EDIEPLT	4-62
Sample Online Application	EDIESOA	4-63
Separator Gateway.....	EDIR100.....	4-64
Separator Driver	EDIR930.....	4-66
X12 Interchange Priority Lookup.....	EDIR931.....	4-68
EDIFACT Interchange Priority Lookup.....	EDIR932.....	4-69
TRADACOMS Interchange Priority Lookup	EDIR933.....	4-70
Monitor Input/Output	EDIR940.....	4-71
Router	EDIR945.....	4-72
Application Log Interface.....	EDIR999.....	4-73
 Chapter 5 File Descriptions		
Overview		5-1
Checkpoint File	EDICKP	5-2
Online Control File.....	EDIOCF	5-4
Queue Files.....	EDIQnnn	5-6
Monitor Header File	EDIRMNH	5-8
Monitor Store File	EDIRMNS.....	5-9
 Chapter 6 JCL Submission and User Security		
Overview		6-1
Configuring JCL Submission and User Security.....		6-2
 Appendix A Jump Codes		
Jump Codes by Screen Title.....		A-1
Jump Codes by Screen Name		A-2
 Appendix B CICS Region Information		
Overview		B-1
CICS Region Requirements		B-2

Enqueue Names B-3
Temporary Storage Queues B-6

Appendix C Flow Charts

Gentran:Control Queue File Maintenance..... C-2
Gentran:Control Screen Flow C-3
Gentran:Control Initialization Processing Flow C-4
Gentran:Control Online Scanner/Initiator Scan Processing Flow..... C-5
Batch Application to Online Application C-6
Online Application to Batch Application C-7
Outbound Translation Batch Application to Batch C-8
Gentran:Control Message Handling and Logging Processing Flow C-9
Gentran:Plus to Gentran:Control Interface to User Application C-10
Gentran:Basic to Gentran:Control to Connect:Enterprise C-11
Gentran:Control Separator Processing Flow C-12

Glossary

Index

Getting Started

Overview

As a subsystem of Gentran:Basic[®], Gentran:Control[®] is an optional component of the most sophisticated EDI management software available. Gentran:Control combines with Gentran:Basic to provide advanced capabilities for both time-critical EDI requirements and CICS-based applications. Gentran:Control enables CICS-based applications and communications to be easily integrated with batch Gentran functions, forming an event-driven EDI system.

For Just-In-Time and similar applications, Gentran:Control enables translation and application processing to be initiated as documents arrive or are to be sent. For applications and communications running under CICS, Gentran:Control provides a secure means of moving documents between CICS and batch environments.

This chapter provides an introduction to Gentran:Control, including system architecture and system operation information.

This chapter contains the following topics.

Topic	Page
Features	1-2
System Overview	1-4
System Components.....	1-4
System Flow.....	1-5
System Operation	1-7
The Queue Facility.....	1-7
Online Input and Output Gateways.....	1-12
Online Scanner/Initiator and Online Batch Initiator	1-13
Online System Control and File Maintenance	1-13
Batch Interfaces.....	1-14
Multiple System Image/Multiple Region Support.....	1-14
File Protection Features	1-17
Document Group/Unit of Work Concepts.....	1-17
Error Handling	1-23
Separator Subsystem	1-25
System Architecture	1-26
System Operation Examples	1-28

Features

With Gentran:Control, you can configure EDI communications to fit your specific needs using several features, including the following:

- Gentran:Control facilities initiate both CICS and batch processing. Several levels of initiation control enable you to implement an automated, event-driven system according to your organization's specific needs. For example, processing can be initiated at specified time intervals or immediately after a designated level (*trigger level*) of documents has been received.
- The Gentran:Control Separator subsystem feature enables you to assign priorities to individual inbound interchanges. The interchanges can be placed in separate queue files for event-driven processing.
- Online functions facilitate file maintenance of Gentran:Control parameters and monitoring of system operation status.
- Online functions enable you to monitor background CICS system activity.
- Gentran:Control enables interfaces to automated operations systems. Errors detected by Gentran:Control may be reported to user control systems via user-supplied exit programs. For example, you can designate a user exit to notify a CICS operator or to send an alert message to an automated operations system.
- A built-in trace facility enables real-time system status information and control. With this facility, you can monitor background CICS Gentran:Control tasks. Using the Gentran:Control maintenance screens, you can deactivate the entire system or portions of the system for application maintenance.

Gentran:Basic operates more effectively with Gentran:Control. In particular, two Central Multiple Queue interfaces (used by Gentran:Control) support the following features:

- The Outbound EDI Extract program (EDID205) can write to a Queue file.
- The Inbound Application Extract program (EDID405) can write to a Queue file.

Gentran:Control provides several advanced features for CICS-based applications and time-critical requirements, including the following:

- CICS Gateways enable CICS-based application and communication programs to exchange documents with the batch Gentran system.
- Documents are queued between the CICS Gateways, the batch Gentran:Basic/Control system, and batch interfaces.
- A CICS/batch document transport mechanism enables CICS applications to send and receive documents automatically from the batch translation environment. This reduces the preparation required in readying CICS applications for EDI and provides the foundation for a CICS-driven EDI system.
- CICS-based applications interface to the batch translation software via a CICS Gateway. The Gateway provides a common application interface for the

Gentran:Control batch and Sterling Commerce CICS translation products, enabling you to EDI-enable applications for both the current and future EDI environments.

- A secure environment for each document between applications and the translation system is provided by CICS and batch programs that are able to send and receive documents to/from the translation software.
- Background CICS errors are recorded on the Online Log file, and error information is exchanged between application and online Gateways, making error handling simpler. The Online Error User Exit program is another (optional) way to handle errors.

System Overview

Gentran:Control facilitates document queuing between applications, the translation system, and communications enabling you to manage your communications data.

System Components

The Queue Facility

The Queue facility enables applications and communications routines to exchange documents with the batch translation system in a continuous and concurrent manner. Queues send and receive transaction data (from either CICS or batch) to Gentran:Basic running in batch. These queues are implemented by VSAM-type data sets known as *Queue files*, which are designed to transport fixed- and variable-length transaction data efficiently between CICS and batch environments.

Online Input and Output Gateways

The CICS input and output gateways provide a program-level interface for CICS application programs to send or receive groups of documents from the batch translation system.

Online Scanner/Initiator and Online Batch Initiator

The Online Scanner/Initiator and Online Batch Initiator functions enable event-driven and time-controlled initiation of both CICS tasks and batch jobs.

Online System Control and File Maintenance

CICS-based system control, file maintenance, and monitoring features enable flexible configuration of your EDI operations; activation/deactivation control over the online system and individual queues; real-time monitoring of CICS activity; and a trace facility.

Batch Interfaces

Interfaces for batch applications to send and receive groups of documents to/from the translation system provide a secure environment for exchanging documents between applications and the translation system.

Multiple System Image/Multiple Region Support

Gentran:Control enables multiple Gentran:Control system images within one CICS region and the use of multiple CICS regions within one Gentran:Control system image.

File Protection Features

Built-in file protection/recovery features record Queue file status information at the successful completion of the job step.

Error Handling

Gentran:Control reports all background CICS errors on the Online Log file. It exchanges error information between Application and Online Gateways, including reporting of application errors on the Online Log file. It also offers an optional Online Error User Exit program to alert the System Operator or to interface with an automation system for unattended system operation when an error occurs.

Separator Subsystem

The separator and router programs that make up this subsystem enable you to separate data interchanges for processing according to priority and then to direct and track the data accordingly. Using the Separator subsystem is optional.

System Flow

The basic system flow of Gentran:Control consists of these steps:

- Data is written to a queue file by one of the Gentran:Control utility programs.
- The Online Scanner/Initiator program verifies that the criteria to process the data has been met.
- The Online Scanner/Initiator program starts the transaction to process the data.
- A Gentran:Control utility program reads the data and passes it on for processing – either by a Gentran translator (Realtime or Basic) or a user application.

Following is a more detailed description of each step.

1. Writing the data

Data written to a queue file can be of any type (i.e. EDI, application, XML, binary, etc.). The Gentran:Control system does not look at the data that is placed on a queue file. (The one exception is if the data is sent to the Separator subsystem that interrogates the data for EDI envelopes.)

Data can be written to a specific queue file from batch or from online (not both). The Source parameter on the queue file description determines which of these is allowed.

When writing from batch, you must place the data in a sequential file and use the batch queue write program (EDIRQWR) to write the data.

When writing from online (CICS), you must place the data in a temporary storage queue (TSQ) and pass the name to the Online Output Gateway (EDIEOOG) to write the data.

When you use the Separator Subsystem (in CICS) to process the data, the data must be placed in a TSQ and pass the name to the Separator Gateway (EDIR100).

2. Verify criteria

The Online Scanner/Initiator program (EDIEOSI) checks if the amount of data on a queue file matches the criteria entered on the queue options. The criteria entered can involve a specific level of data (for example, 5 documents), a time interval (for example, 30 seconds after the data was written) or a combination of both.

3. Start the process

The Online Scanner/Initiator program (EDIEOSI) issues a CICS start command to process the data if the criteria has been met. Two types of transactions are used: one to read the data in CICS and pass it along, the other transaction submits JCL to run the read process in batch.

4. Read process of the data

The data is read from the queue file and passed to the destination specified.

The utility used to read the data is determined by the Action to Initiate parameter on the queue options. The data can only be read by a batch utility or by a CICS utility (not both).

In batch, the queue read utility (EDIRQRD) reads the data and writes it to a sequential file.

In CICS, the queue read program (EDIEOQR or EDIROQR) reads the data and passes it via a TSQ to the destination program.

System Operation

The Queue Facility

Gentran:Control system design is based on queues, which send and receive transaction data. The data can be sent from CICS to CICS, CICS to batch, batch to CICS, or batch to batch. The sending and receiving ends in this process can be Gentran:Realtime[®], Gentran:Basic, user applications, or user communications.

The queue facility enables applications and communications routines to exchange documents in a continuous and concurrent manner. Queues are implemented by VSAM-type data sets known as *Queue files*.

A Queue file is an Relative Record Data Set (RRDS) VSAM data set, which performs a first-in, first-out *wrap-around* process. The wrap-around process is controlled by pointers created by Gentran:Control in the first two records, which identify where the data begins and ends. The remaining records on the file are used to hold the data being processed.

When data is read and written, the appropriate pointers are updated. Data integrity is maintained by limiting file access to Gentran:Control online and batch utility programs. You **cannot** write directly to the file from your own programs.

The queue facility can transport both fixed and variable-length transaction data efficiently because of its method of storing the data on the file. All data is stored as variable-length records, with the logical records blocked onto each queue record. Each queue record is the size of the Control Interval on the Queue file.

Configuration

Each Queue file has one *source* process, which *writes to* the queue, and one *server* process, which *reads from* the queue. The source and server processes are defined through online screens and may be either online or batch. The following list illustrates some of the possible Queue file configurations.

Source of the Data	Server (Processor of the Data)
Gentran:Basic System	Batch Application
Gentran:Basic System	Online Application
Online Application	Gentran:Basic System
Online Application	Batch Application
Batch Application	Gentran:Basic System
Batch Application	Online Application
Batch Application	Batch Application
Batch Application	Gentran:Realtime
Gentran:Realtime	Batch Application
Online Application	Gentran:Realtime
Gentran:Realtime	Online Application
Online Application	Online Application

Defining Queue Files

Queue files are identified by a three-digit number within Gentran:Control. Up to 990 Queue files may be defined, with the Queue file numbers ranging from 001 to 999 (the numbers 091 to 099 have been reserved for special internal use within Gentran:Basic and Gentran:Realtime).

Queue files do not require ongoing maintenance or reorganization. When first defined, they must be initialized by the Queue File Maintenance program (EDIEQMT). This program pre-formats the data set and records information about the Queue file in the Checkpoint file and the first two records of the Queue file.

When in use, Queue files *wrap around* by returning to the top of the file when the bottom is reached. The file is full when the pointers indicate that all records are filled with data. When the records are filled with data, the Queue file is disabled; attempts made to write to it will fail. Reading the files updates the pointers, making the file available for new data. Therefore, Queue files initially should be defined to accommodate the largest data volume expected.

Queue File Access

Program-level access to the Queue files is strictly controlled through Gentran:Control input/output routines. These routines are of the following three types:

- **Central Multi-queue Routines**
The batch process uses these routines to read and write multiple Queue files in one execution. These programs are accessed by Gentran:Control utility programs and cannot be accessed directly by user programs.
- **Online Single-queue Routines**
The Gentran:Control Online Gateways use these routines to read and write Queue files. Each task reads or writes only one Queue file. User programs access these routines by linking to a gateway (for writing) or by being called by the gateway (after the data has been read).
- **Remote Single-queue Routines**
User-developed programs (samples are provided with Gentran:Control) use these routines to read and write to one Queue file per job step.

Communication of queue status information between central, online, and remote routines is controlled by information recorded in the individual Queue files and in the Checkpoint file.

Note: The Gentran:Control routines contain a strict record-sharing discipline based on standard VSAM facilities for data set sharing. Gentran:Control uses the VSAM *SHAREOPTIONS* to provide immediate disk writes and buffer invalidation of previous disk reads. The *SHAREOPTIONS* are set up for access from any source, but the utilities enforce a process in which a given record (for example, Control Interval) can be read by many routines but can be updated by only one.

Queue File Architecture

The following components make up the Queue file architecture:

- **Online Output Gateways**
Send data to a Queue file.
- **Online Input Gateways**
Receive data from a Queue file.
- **Queue Files**
RRDS VSAM used to hold data.
- **Batch Write and Batch Read**
(utility programs) Use the multi-queue interfaces to pass data to Queue files.

Figure 1.1 illustrates Gentran:Control Queue file architecture.

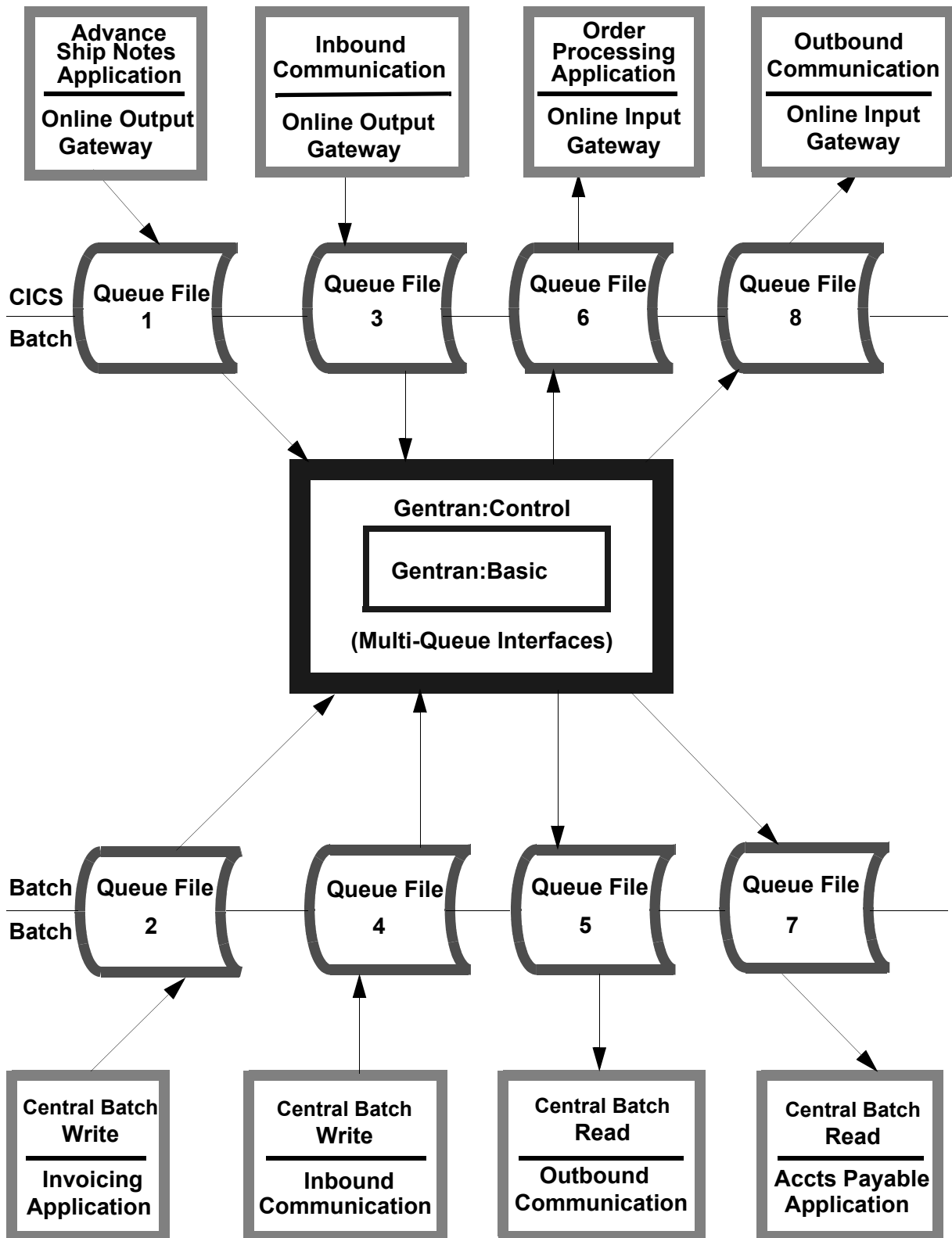

Figure 1.1 Gentran:Control Queue File Architecture

Concurrent Processing Options and Restrictions

Gentran:Control enables partial concurrent processing of online and batch applications. Processing between different Queue files is independent; all defined Queue files can process concurrently. For a given Queue file, however, the processes are restricted to one read and one write occurring simultaneously.

When the reads and writes are performed in the online environment, Gentran:Control completes all locking required to restrict access. The locking is performed by Gentran:Control programs issuing CICS ENQ commands on the Queue file being read or written. The ENQs issued by Gentran:Control are in effect for the entire task. You need to define ENQs in the ENQMODEL defined for your CICS region.

See Appendix B for CICS Region information in this guide.

In the batch environment, the queue read and write programs (EDIRQRD and EDIRQWR) perform system enqueues on the queue file names they are accessing. When accessing multiple queue files, these programs enqueue on all of the files before starting to process them. They hold the files for the duration of the process and dequeue at the end.

The following restrictions apply to concurrent processing operations:

- Online applications for different Queue files may run concurrently.
- Online applications for the same Queue file are serialized by the Online Queue routines.
- Batch applications for different Queue files may run concurrently.
- Batch applications for the same Queue file must be run one at a time. When using the EDIRQRD and the EDIRQWR programs, these programs enqueue on the queue files to ensure single threading. When you use the single remote write or read, you are responsible for enforcing this restriction.

Online Input and Output Gateways

The CICS input and output gateways provide a program-level interface for CICS application programs to send or receive groups of documents from the batch translation system.

The output gateway is called by a user program to send data to a queue file. The gateway can be used by CICS-based applications to send outbound application data to the batch translation system or by CICS-based communications routines to forward inbound EDI data to the batch translation system. Immediate batch processing also can be initiated.

The input gateway retrieves data from a queue file and initiates user-specified processing. The gateway can be used by CICS-based applications to receive inbound application data from the batch translation system or by CICS-based communications routines to obtain outbound EDI data from the batch translation system.

Online Scanner/Initiator and Online Batch Initiator

The Online Scanner/Initiator and Online Batch Initiator functions enable event-driven and time-controlled initiation of both CICS tasks and batch jobs. At regular intervals, the Online Scanner/Initiator scans all the Queue files to determine whether any CICS or batch processing is to be initiated according to criteria you set on the maintenance screens. If process initiation is indicated, then separate CICS tasks are created to process the documents or to initiate batch processing.

The Online Batch Initiator program starts batch processing by writing JCL to the Internal Reader. JCL to be submitted is stored in user-prepared files. The Online Control file specifies which JCL is to be submitted.

Processing may be initiated by the Online Batch Initiator based on either document trigger levels or interval times set on the maintenance screens. Processing also may be initiated at different intervals, based on the day of the week and time of day, entered on the Extended Queue Options Maintenance screen. Document trigger levels enable documents to be batched at appropriate user-determined levels.

See the Screens Chapter in this guide (*System Options Maintenance* and *Queue Options Maintenance* screens) for information about setting trigger levels, interval times, etc.

Online System Control and File Maintenance

The operational features of Gentran:Control include CICS-based system control and file maintenance, and CICS-based monitoring of Gentran:Control background CICS activity.

The following list describes the online operational features of Gentran:Control.

- The maintenance feature provides real-time operational control and configuration of the online portion of Gentran:Control. Both the online system and individual queues can be activated and deactivated for either application or system maintenance periods.
- The Online Control file parameters enable flexible configuration of your Gentran:Control operations. System-level parameters include the Scan Interval parameter and System Status parameter. In addition, a system trace option activates a built-in trace facility. At the individual queue level, a series of options enables you to control the initiation of either CICS or batch processing.
- The Online Log Display enables real-time monitoring of the CICS portion of the Gentran:Control system. All system error conditions, including possible “system under stress” errors due to CICS or batch stalls, are reported on the Online Log file.
- For real-time serviceability, you can activate the built-in trace facility from the Gentran:Control maintenance screens. This trace facility enables you to monitor background CICS Gentran:Control tasks.

Batch Interfaces

Interfaces for batch applications to send and receive groups of documents to/from the translation system provide a secure environment for exchanging documents between applications and the translation system. These batch interfaces consist of subroutines to read and write records from the queues. Sample programs (EDIESQR and EDIESQW) described in the Program Descriptions chapter in this guide illustrate the use of these subroutines.

A system shutdown process for maintenance jobs can also be initiated from batch. You need to initiate the EDIX transaction from a batch process, then follow this with the Wait program EDIWAITD. The EDIX transaction changes the system status to a quessing status. The Online Scanner/Initiator program changes the system status to disabled when it sees the quessing status (this allows all currently running processes to complete and prevent any new processes from starting). The Wait program checks that the system status becomes disabled before proceeding. (It performs a wait and then wakes up every few seconds to check the status.)

Multiple System Image/Multiple Region Support

With Gentran:Control, you can set up multiple system images within one CICS region. You also can use multiple CICS regions within one Gentran:Control system image.

Multiple System Images

Gentran:Control supports multiple system images (such as a test system and a production system) of Gentran:Basic and Gentran:Control and enables them to function within one CICS region. Each system image has its own set of data files.

In the batch environment, each system image references its own files through different JCL. In the CICS environment, a three-character System Image ID identifies all files belonging to a particular system image. Normally, this System Image ID defaults to EDI. All file DDnames, all CICS tsqnames, and CICS enqueue names are prefixed by this three-character System Image ID.

Multiple Region Support

Gentran:Control enables multiple CICS regions to communicate with one Gentran:Basic batch system image. Two examples of this configuration follow.

Example 1.

Two CICS applications running in different CICS regions can send transactions to a common Gentran:Basic batch system. Gentran:Control is replicated in each region.

In this configuration, the online portion of the Gentran:Control system is present in each of the two CICS regions. Each CICS region accesses its own unique Queue files and Gentran:Control files (EDIOCF and JCL). The Queue files *cannot be shared*. The full Gentran:Basic system need not be created on each of the CICS regions. The Gentran:Basic system can be limited to the Security file, Configuration file, and the following screens and programs:

- Gentran Logon screen (EDIX000, EDIZ000)
- Gentran Main Menu (EDIX001, EDIZ001)
- Administrative Maintenance (EDIX210, EDIZ210)
- Security Maintenance Menu (EDIX200, EDIZ200)
- User ID Directory (EDIX203, EDIZ203)
- User ID Maintenance (EDIX201, EDIZ201, EDIX202, EDIZ202)

Gentran:Control must include all the programs and transactions but only the Queue files needed for each region.

Example 1.

Figure 1.2 Multiple Region Support Example 1

Example 2.

Two CICS applications running in different CICS regions can send transactions to a common Gentran:Basic batch system. Gentran:Control is not replicated in each region.

In this configuration, the online portion of the Gentran:Control system resides in only one region. The user applications within the second region write their data into TSQs that reside on the CICS region owning the Gentran:Control system. The applications must issue a start command for an interface transaction (EDIA) to process in the owning region. The transaction then passes the data to Gentran:Control. This interface approach requires the use of Multi Region Option (MRO) Support to communicate between the CICS regions.

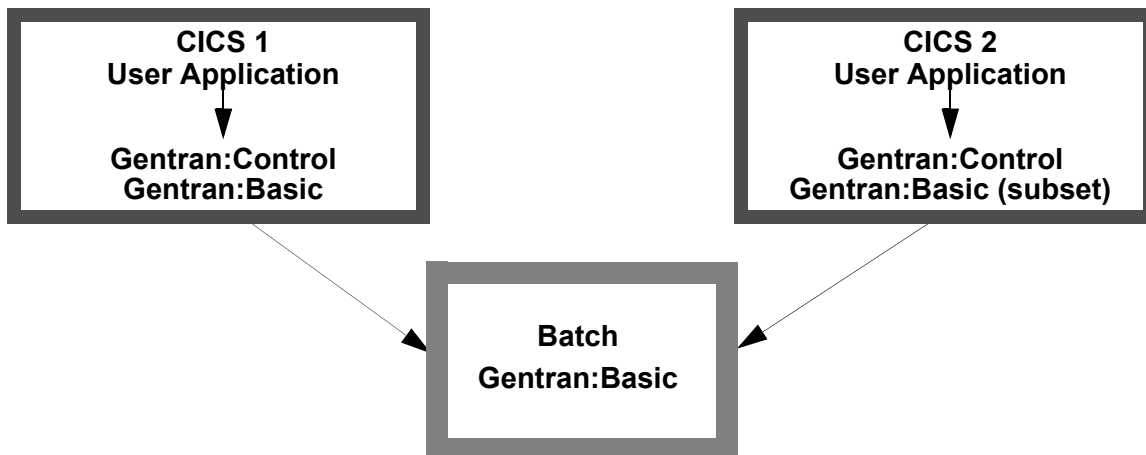
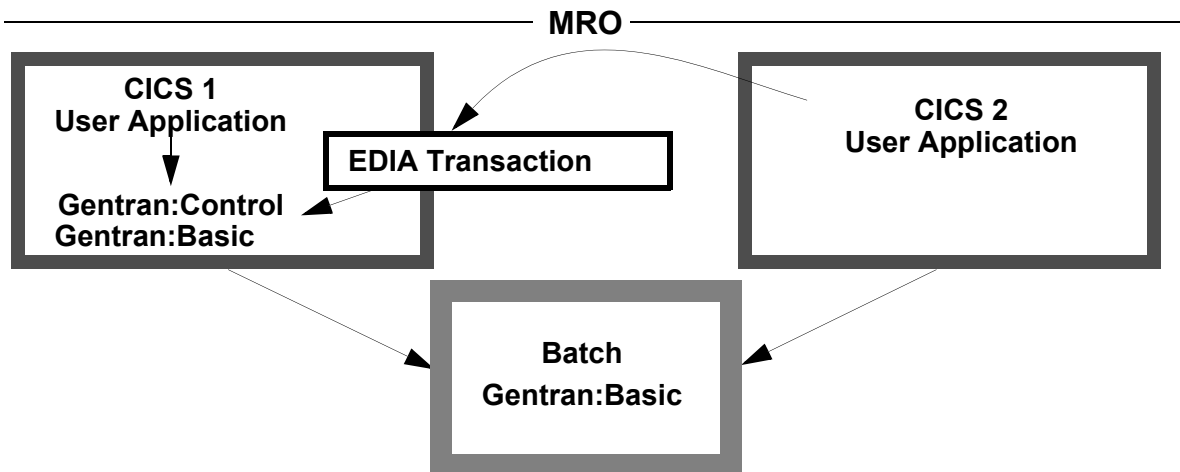

Figure 1.3 Multiple Region Support Example 2

File Protection Features

File Sharing Between Batch and CICS

Gentran:Control provides data transport capabilities between batch and CICS. The Gentran:Control routines contain a strict record-sharing discipline based on standard VSAM facilities for data set sharing. Gentran:Control uses the VSAM *SHAREOPTIONS* to provide immediate disk writes and reads. The *SHAREOPTIONS* are set up for access from any source, but the utilities enforce a process in which a given record (for example, Control Interval) can be read by many routines but can be updated by only one.

Note: The use of any other system feature that negates the above provisions causes Gentran:Control to fail intermittently.

Built-in file protection/recovery features in Gentran:Control ensure a secure environment for concurrent online and batch processing. The files are protected because Gentran:Control utility programs are the only means of accessing the Queue files. The recovery feature posts the data at the end of the Document Group (Unit of Work). Concurrent batch processing is enabled by using enqueues to prevent multiple batch jobs from reading or writing the same queue file.

Document Group/Unit of Work Concepts

Document Group and *Unit of Work* are identical concepts; both terms refer to the set of application records or EDI records that are passed to the Gentran:Control system for processing. For example, when data is passed in a TSQ to the Online Output Gateway, all the data in the TSQ is considered to be in one Document Group, regardless of the quantity of EDI interchanges it contains.

Note: The TSQ Chaining feature enables you to *chain* your TSQs together so the interchanges in multiple TSQs move to and from the user program as one set of data. If you are using the TSQ chaining option, all the chained TSQs are one Document Group.

A Document Group is treated as one Unit of Work when it is passed to Gentran:Control. As Document Groups accumulate on the Queue file, they become the Unit of Work for the read process.

Example:

Online communications receives EDI data every 10 minutes from a network. Over a 30-minute period, communications receives the data indicated in the following list:

Time Interval at which Batch is Received	
10 minutes	10
20 minutes	3
30 minutes	8

Each batch becomes a Document Group in Gentran:Control in the following manner:

1. As each Document Group is received, the interchanges within the batch are written to a Queue file.
2. Every 30 minutes, Gentran:Control starts the Gentran:Basic inbound translation process. At that time, a Gentran:Control utility program reads all the data (interchanges) from the Queue file.
3. Each group of interchanges (or Document Group) becomes a Unit of Work; in this case, three Document Groups become one Unit of Work of 21 interchanges.

When data is written onto a Queue file, it is blocked into a Queue record and written to the file. The pointers are not updated until the full Document Group has been completed. When data is read from a Queue file, it is unblocked and written to a sequential file, but the pointers are updated only after all data has been read and processed successfully. Because the pointers are updated as the last step in either process, the data is not added to the file or removed from the file until the program has completed successfully.

The following list and Figure 1.4 through Figure 1.9 summarize Unit of Work concepts.

Batch Write	All data on the Sequential file processed in the job step
Online Application Read	All data that was written to the Queue file in a previous Document Group
Online Application Write	All data in the Temporary Storage queue (TSQ) processed in the task
Batch Read	All data currently available on the Queue file

Note: In Figure 1.4 through Figure 1.9, letters within circles represent records that comprise a Document Group placed on the Queue files. The letters correspond to the letters referred to in the descriptions following the figures.



**Figure 1.4 Document Group/Unit of Work
Batch Write**

Batch Write

When data is written to a Queue file, the Checkpoint file and the Queue file save status information at the successful completion of the job step. The complete file that is used as input to the Batch Write utility program (EDIRQWR) is considered to be the Document Group for that process. The file could be one document, many documents, one EDI interchange, or many EDI interchanges. The utility program reads to the end of the file and sets that as the Document Group. In Figure 1.4, A contains all the records on the Sequential file and is the Document Group on the Queue file.

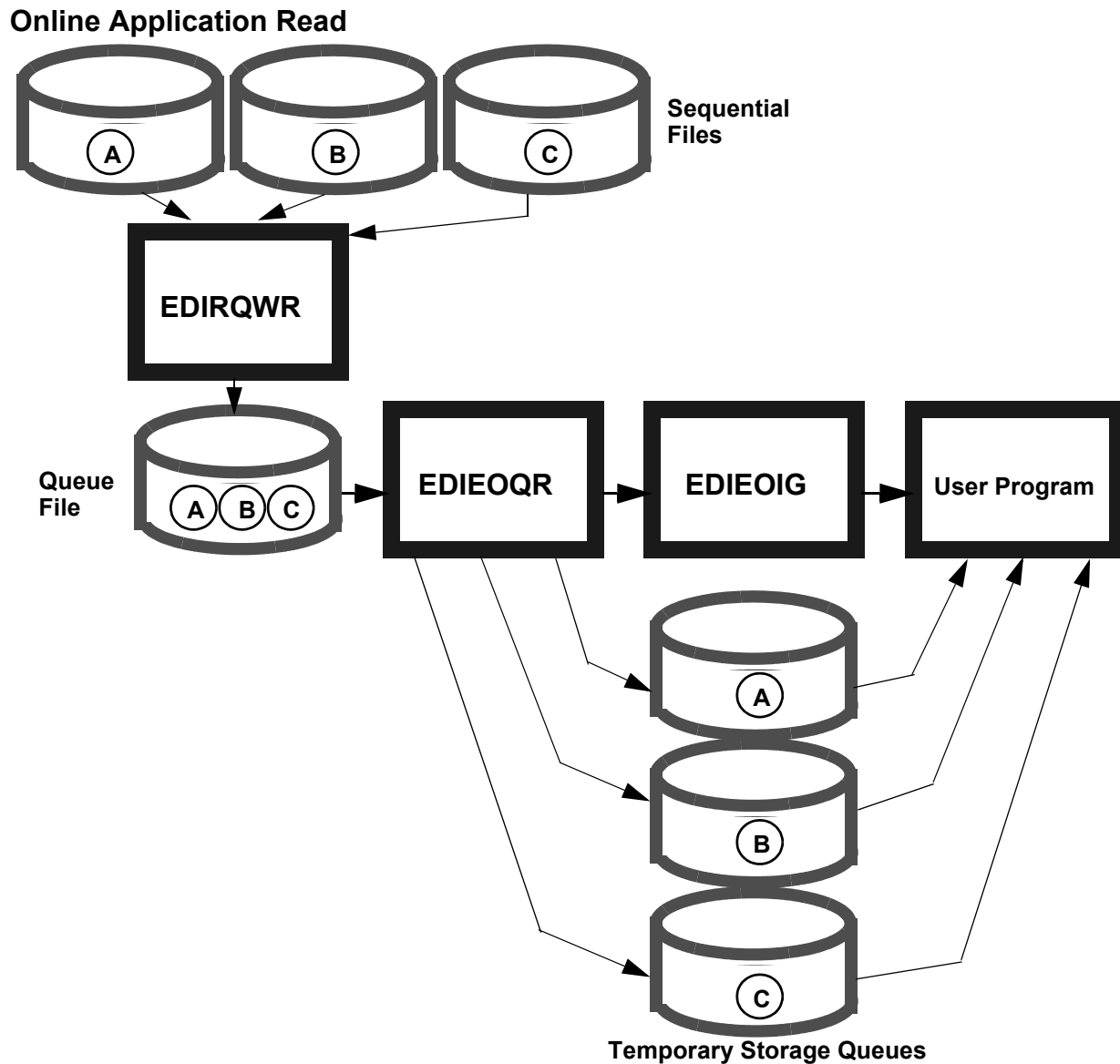

**Figure 1.5 Document Group/Unit of Work
Online Application Read**

Online Application Read

Each time the Batch Write program runs, it places a Document Group (A, B, and C in Figure 1.5) on the Queue file. When a trigger level is satisfied, Gentran:Control starts the online read process.

The Online Queue Read Program reads the Queue file and writes the first Document Group to a TSQ, then links to the Online Input Gateway. The Gateway passes the TSQ to the user program. After the first Document Group is processed, the Online Queue Read program looks for the next Document Group and passes the Document Group through the process. In this way, each Document Group is processed as a separate Unit of Work in the Online Queue Read process.

Online Application Write

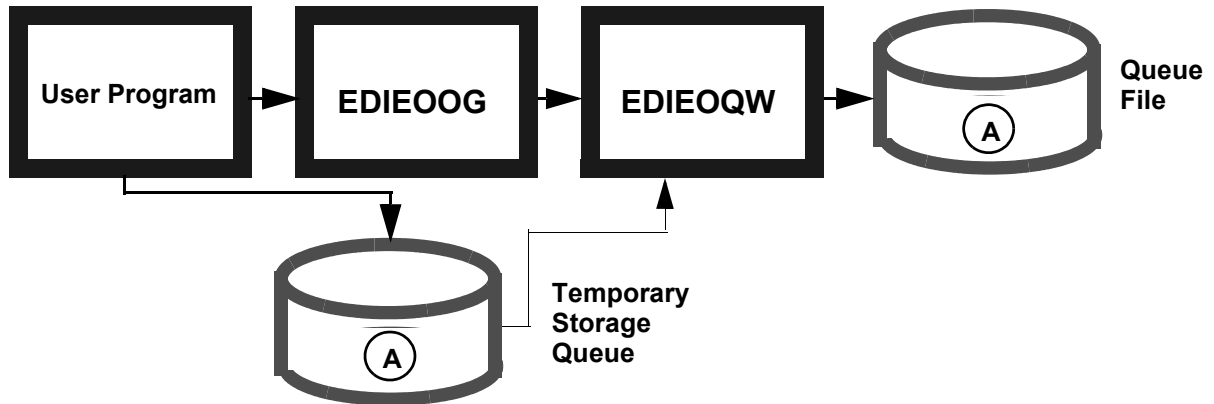

**Figure 1.6 Document Group/Unit of Work
Online Application Write**

Online Application Write

When a user application writes data to a Queue file in CICS, the program must pass the data in one or more TSQs. Normally, all the data passed in the TSQs for a single CICS task is considered one Document Group (A). The user program can control the number of Document Groups by setting parameters in the communication link area to EDIEOOG. The parameters that must be set are the BEGIN DOCUMENT and the END DOCUMENT indicators.

See “Online Output Gateway EDIEOOG” in Chapter 4, “Program Descriptions,” in this guide for information about parameter settings.

The Online Output Gateway and Queue Write programs (EDIEOOG and EDIEOQW) perform the work needed to validate the data and update the Queue file.

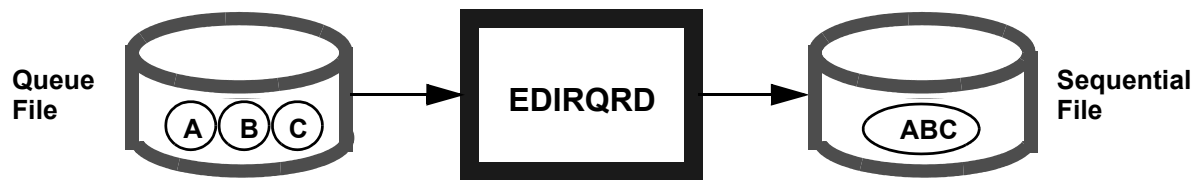
Batch Read

**Figure 1.7 Document Group/Unit of Work
Batch Read**

Batch Read

When data is read from a Queue file, the Checkpoint file and the Queue file hold the status information used to determine what data is to be read. All data currently available on the Queue file (determined by the pointers) is considered the Document Group. The Batch Read utility program (EDIRQRD) uses the current values of the pointers to determine which records are to be read for the Document Group. If these records were part of multiple Document Groups (A, B, and C in Figure 1.7) when written to the Queue file, they become one Document Group (Unit of Work) for batch reads, consisting of A, B, and C.

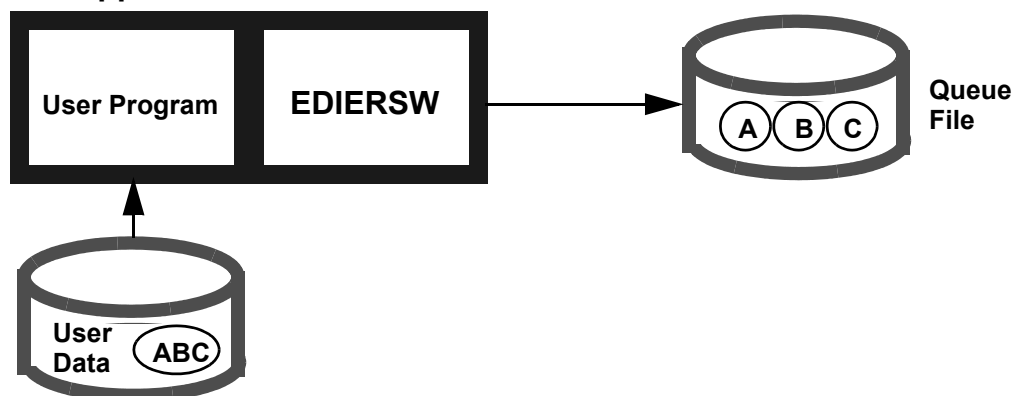
User-Written Application Write

**Figure 1.8 Document Group/Unit of Work
User-Written Application Write**

User-Written Application Write

A user program writes data directly to a Queue file by calling the Remote Single-queue Write program (EDIERSW). The user program determines the amount of data in a Document Group. The user application can set a break for a Document Group at any logical point within the process. This break updates the pointers and enables the data written up to that point to be read. The application can write one or more Document Groups during a job step.

In this example, ABC is one data file consisting of three EDI interchanges. During processing, the user program sets the Document Group indicators at the end of each interchange.

See “Remote Single-Queue Write Subroutine EDIERSW” in Chapter 4, “Program Descriptions,” in this guide for additional information on program operation.

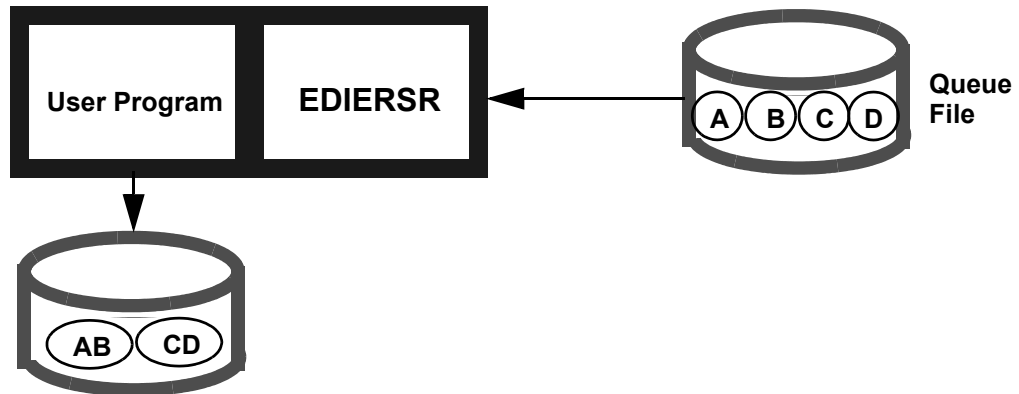
User-Written Application Read

**Figure 1.9 Document Group/Unit of Work
User-Written Application Read**

User-Written Application Read

A user program reads data directly from a Queue file by calling the Remote Single-queue Read program (EDIERSR). The user program determines the amount of data in a Document Group. The application can decide to break for a Document Group at any point in the data that corresponds to a Document Group that was written to the file. For example, if there are four Document Groups on the file, the read program can break at each of the four or at multiples of the four. Breaking for a Document Group updates the pointers to identify the data as having been processed off the Queue file.

In Figure 1.9, the user program reads four Document Groups from the Queue file and regroups them into two Document Groups on output, according to data type.

See “Remote Single-Queue Read Subroutine EDIERSR” in Chapter 4, “Program Descriptions,” in this guide for additional information.

Error Handling

Gentran:Control contains the following features for automating error handling in background CICS processing:

- Reporting of all background CICS errors on the Online Log file
- Exchange of error information between application and online gateways, including reporting of application errors on the Online Log file
- Optional Online Error User Exit program

Online Log File

The Online Log file is an RRDS VSAM data set that processes in a wrap-around fashion. All background transactions for all Gentran products (Gentran:Basic, Gentran:Control, and Gentran:Realtime) use this data set to record errors. You can view the Online Log file in real-time for immediate diagnosis of the system condition, using the Online Log Display and the Online Log Detailed Display.

The screens display the same information, but the detail screen enables you to search or review a particular task.

Batch program EDIELMT must format the Online Log file before it can be used by any Gentran system. This program also can be used to print all the messages for a specific task to provide a detailed list for debugging purposes.

See “Log File Maintenance EDIELMT” in Chapter 4, “Utility Programs,” in the *Gentran:Basic Technical Reference Guide* for additional information about the Online Log file.

Exchange of Error Information

Error information is exchanged between user applications and Gentran:Control gateways via the communication link area. The CICS communication link areas contain message fields identifying any errors. The Online Output Gateway and Online Input Gateway provide different capabilities to suit the directional requirements of the gateway.

The Online Output Gateway, after detecting an error, returns a copy of the error message. If your organization requires that the terminal operator be notified of error information, you must design the program linking to the gateway to use the error handling facility according to your needs.

The Online Input Gateway enables the application to return a message, which is written to the Online Log file. Thus, application errors are recorded in the Online Log file, alerting a Gentran:Control System Operator of the application condition.

Optional Online Error User Exit Program

You can configure Gentran:Control to invoke a user-supplied program when an error occurs in the background CICS system. This program can be used to interface with a data center automation system for unattended system operation or to alert the Gentran:Control System Operator of the error.

Separator Subsystem

The operational features of the Separator subsystem include CICS-based system control, automatic routing, and CICS-based monitoring. The Separator enables you to set priorities and assign processes (such as sending the data to a queue file, a Gentran:Realtime option, or a user application) for inbound EDI data.

The Separator and priority programs divide individual interchanges within a communications batch and distribute them according to the priority assigned by the programs. The Router program processes the interchanges according to the assigned priority.

You can identify the transactions for which you wish to set priorities using the following screens:

- Separator Main Menu screen (EDIM934)
- Separator Options Maintenance screen (EDIM935)
- Priority Options Directory screen (EDIM936)
- Priority Options Maintenance screen (EDIM937)
- Separator Monitor screen (EDIM938)

Figure 1.10 illustrates the ways the Separator subsystem screens interact.

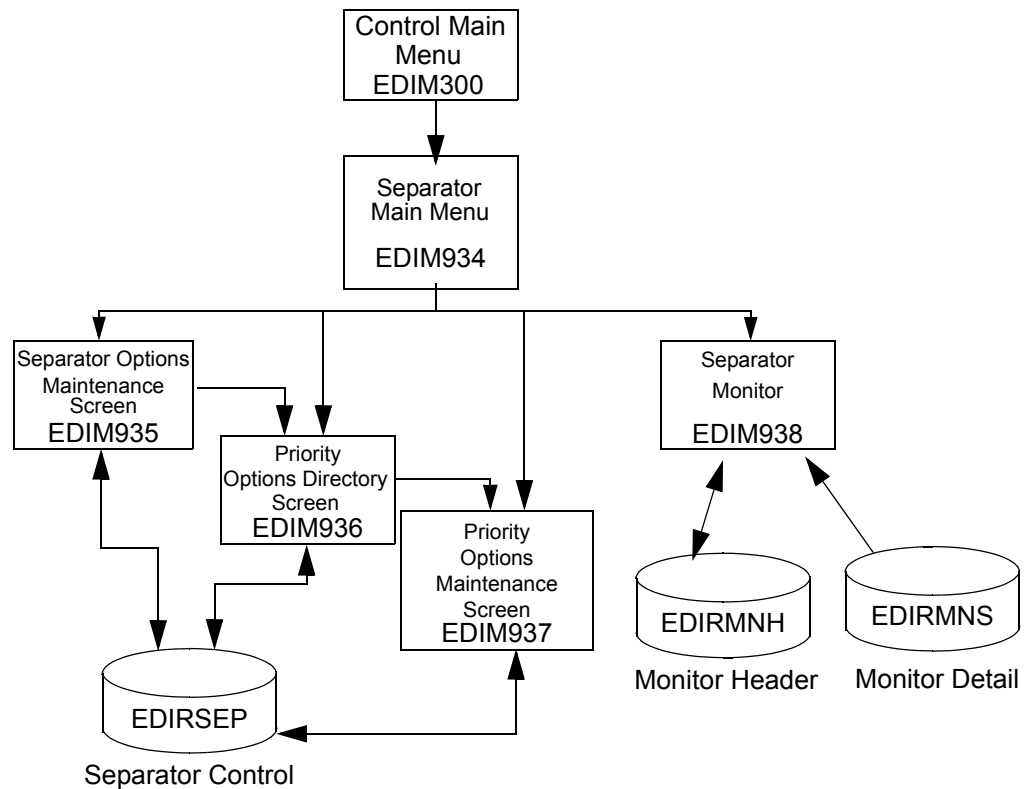

Figure 1.10 Separator Subsystem Screen Flow

System Architecture

To transport data between CICS and batch environments and to initiate CICS and batch processing, the Gentran:Control online system uses standard CICS command-level functions and standard VSAM data set sharing features.

Figure 1.11 illustrates the Gentran:Control program flow. The numbers in the illustration correspond to the steps below the figure that describe the flow.

See the “Flow Charts” appendix in this guide for additional information.

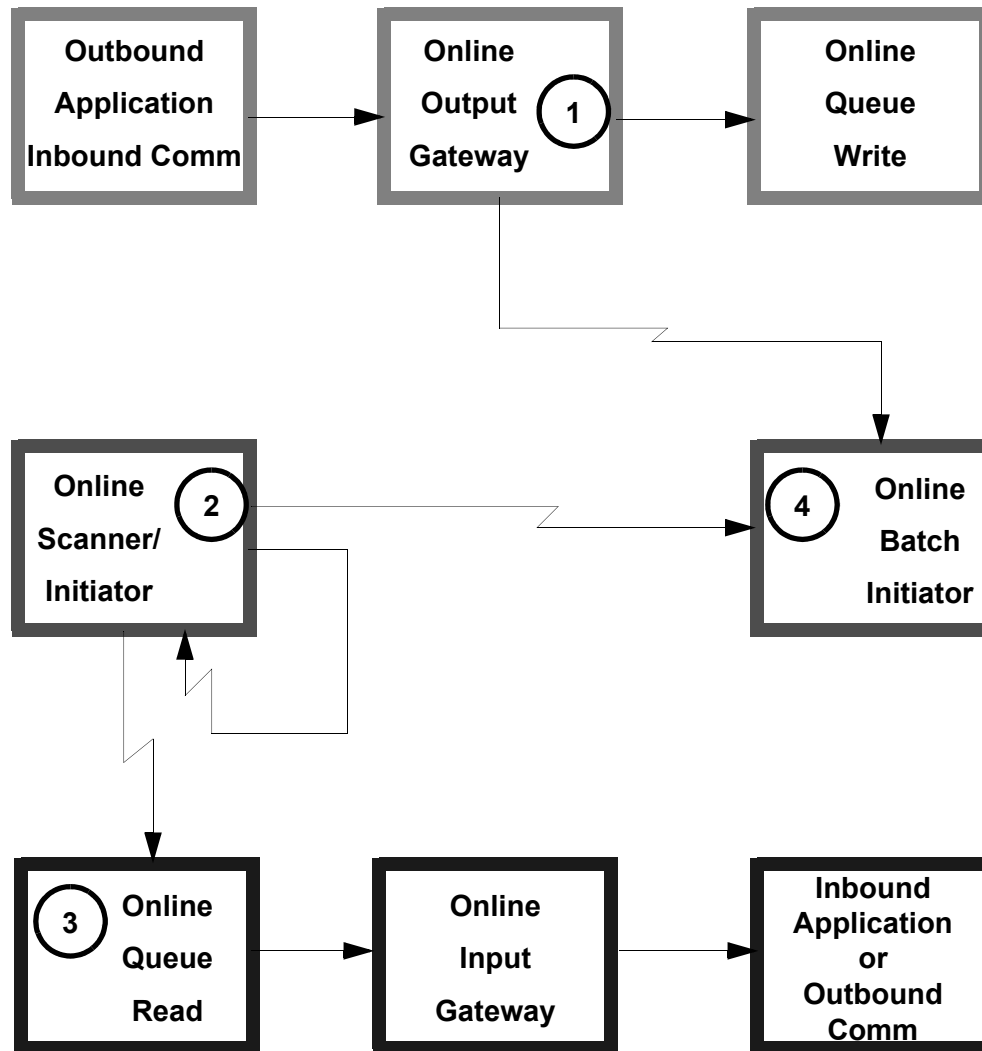

Figure 1.11 Gentran:Control Program Flow

The following steps describe the program and initiation functions of Gentran:Control.

1. Outbound applications or inbound communications link to the Online Output Gateway. The Online Output Gateway then links to the Online Queue Write program. Upon return, the Online Output Gateway may start the Online Batch Initiator.

2. The Online Scanner/Initiator periodically runs and determines whether online and batch processing functions are required. If CICS processing is required for data coming into the CICS system, the Scanner starts an Online Queue Read task for each Queue file that has input data. If batch processing is required, the Scanner starts an Online Batch Initiator task. The Online Scanner/Initiator schedules itself to re-start after a user-defined interval.
3. The Online Queue Read links to the Online Input Gateway for each group of documents. The Online Input Gateway then links to an inbound application or outbound communication. If multiple groups of documents are available, the Online Input Gateway is linked to repeatedly.
4. The Online Batch Initiator submits JCL contained in the JCL files to the batch system for processing.

System Operation Examples

Five examples of Gentran:Control system operation are illustrated in Figure 1.12 through Figure 1.16. The numbers in the illustrations correspond to the steps below the figures that describe the activity.

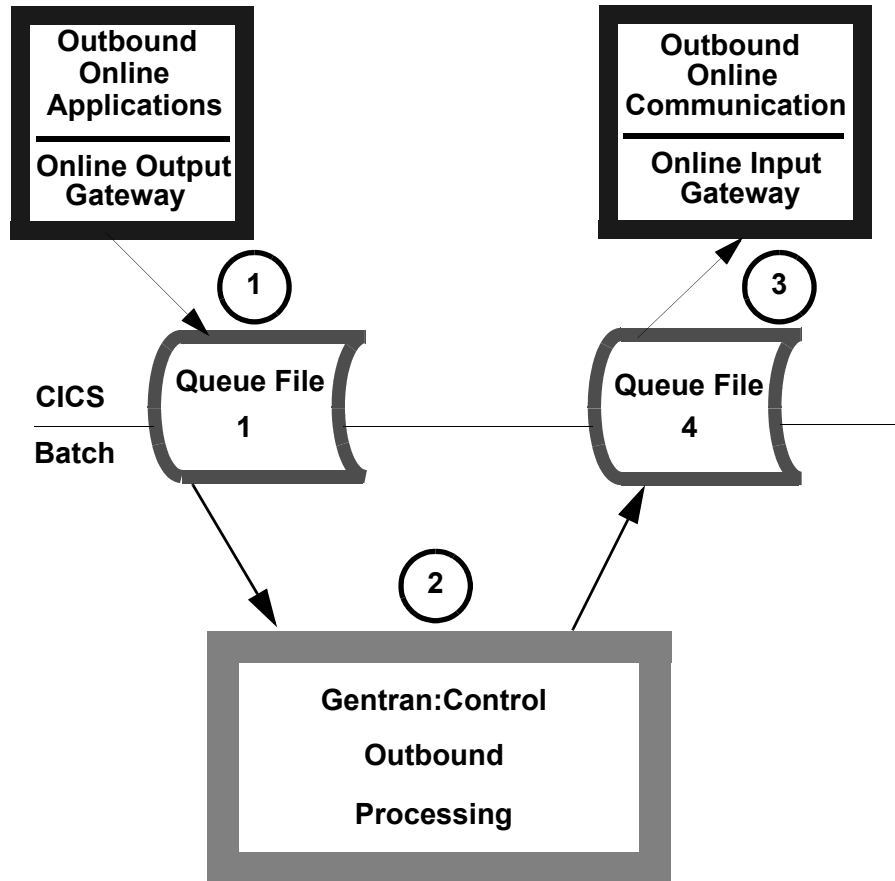

Figure 1.12 Example of System Operation – 1 of 5

The following steps describe the activity illustrated in Figure 1.12.

1. **Outbound Online Applications**
Advance Ship Notices (ASN) are created by the CICS application, which then calls the Online Output Gateway. The Online Output Gateway writes the documents to Queue file 1.
2. **Outbound ASN Gentran:Basic/Control Job Stream**
The presence of ASNs in Queue file 1 triggers Gentran:Control to submit JCL for the Outbound translation ASN job stream. Control cards specify the records from Queue File 1 that are to be processed. After generating the documents to be sent, control cards specify that the documents are to be sent to Queue File 4.
3. **Outbound Online Communications**
The presence of EDI data in Queue File 4 triggers Gentran:Control to initiate the CICS Online Queue Read/Online Input Gateway task. This task reads EDI data from Queue File 4, then calls the user-supplied CICS communications interface.

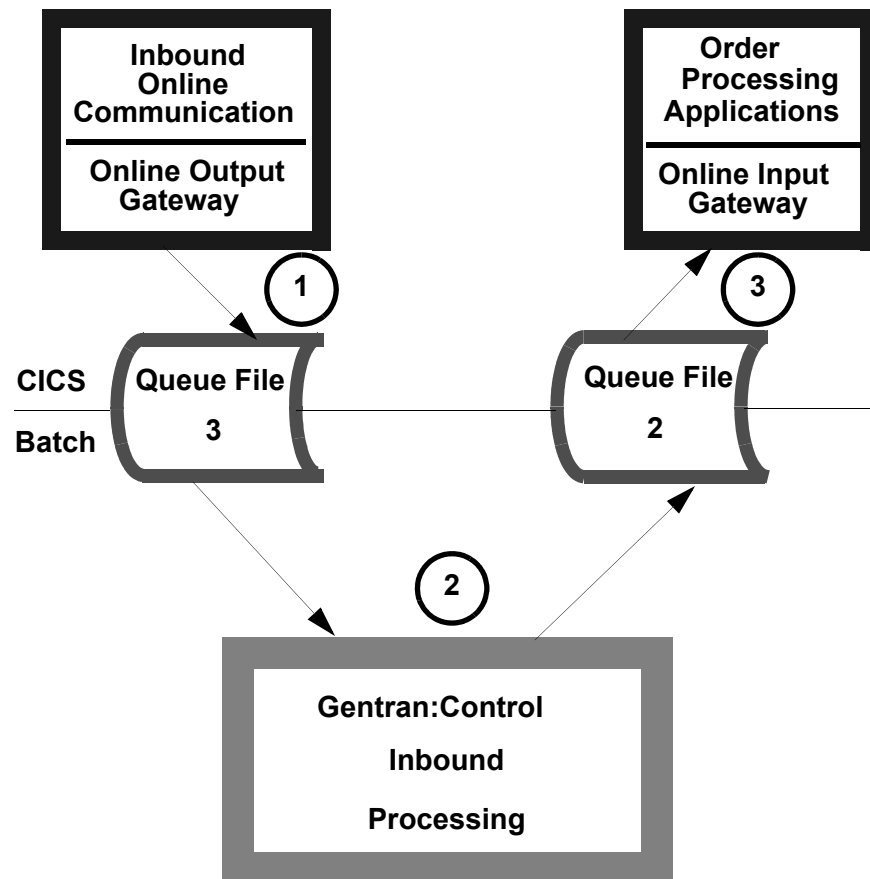

Figure 1.13 Example of System Operation – 2 of 5

The following steps describe the activity illustrated in Figure 1.13.

1. **Inbound Online Communications**
Data from the CICS communications interface is passed to the Online Output Gateway/Online Queue Write programs and is written to Queue File 3.
2. **Inbound Translation Job Stream**
The presence of EDI data in Queue File 3 triggers Gentran:Control to submit JCL for the Inbound Translation job stream. Control Cards specify the records from Queue File 3 that are to be processed. Separate job steps specify that documents for the order processing application are to be written to Queue File 2.
3. **Inbound Online Order Processing Application**
The presence of documents in Queue File 2 triggers Gentran:Control to initiate the CICS Online Queue Read/Online Input Gateway task. This task reads application data from Queue File 2 and then calls the user order processing application.

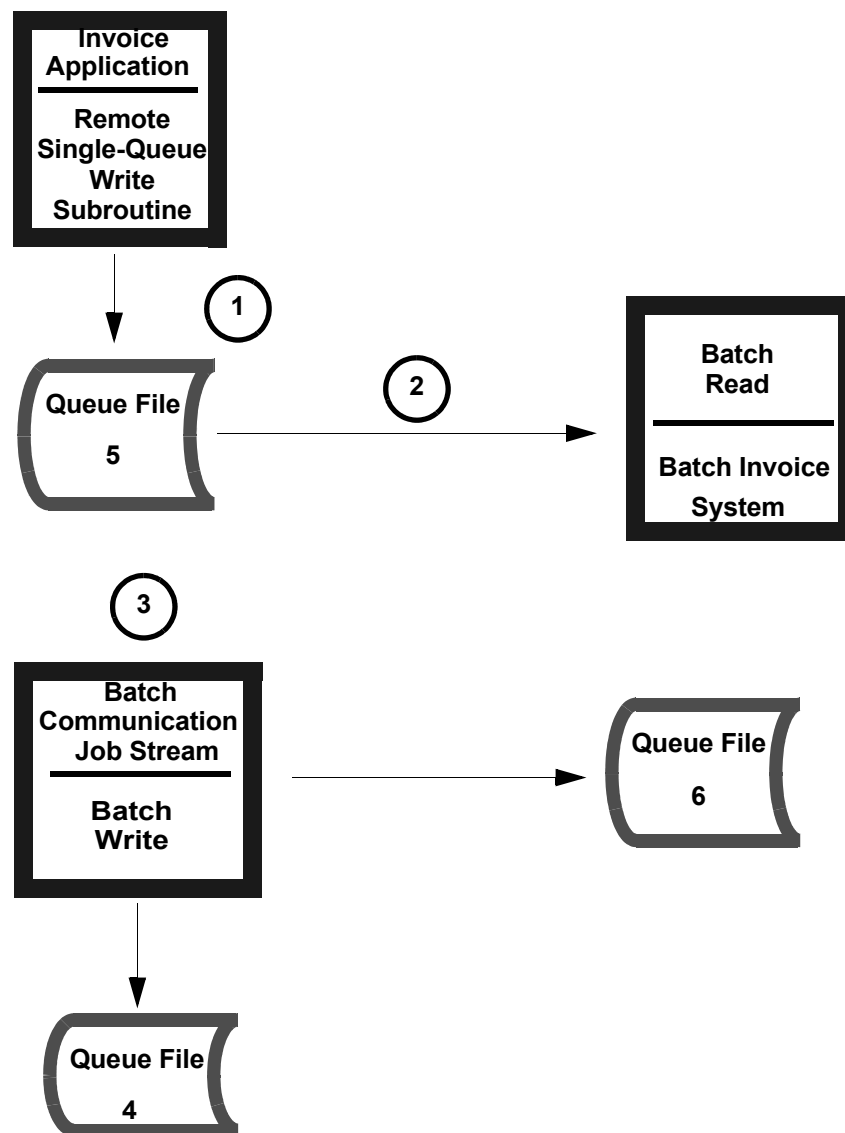

Figure 1.14 Example of System Operation – 3 of 5

The following steps describe the activity illustrated in Figure 1.14.

- 1. Outbound Batch Invoicing Application**
Invoices are created by the batch application, which then calls the Remote Single-queue Write subroutine. The subroutine writes the documents to Queue File 5.
- 2. Outbound Invoice Generation Job Stream**
The Gentran:Basic/Control invoice job stream runs on a schedule. Control cards to the Central Batch Read program specify that Queue File 5 is to be processed.
- 3. Outbound Batch Communications Preparation Job Stream**
The outbound Gentran:Basic/Control job stream runs on a schedule. Data separation creates multiple files that are passed to the Batch Write program. Control cards specify that documents for the online network are sent to Queue File 4 and that documents for the batch network are sent to Queue File 6.

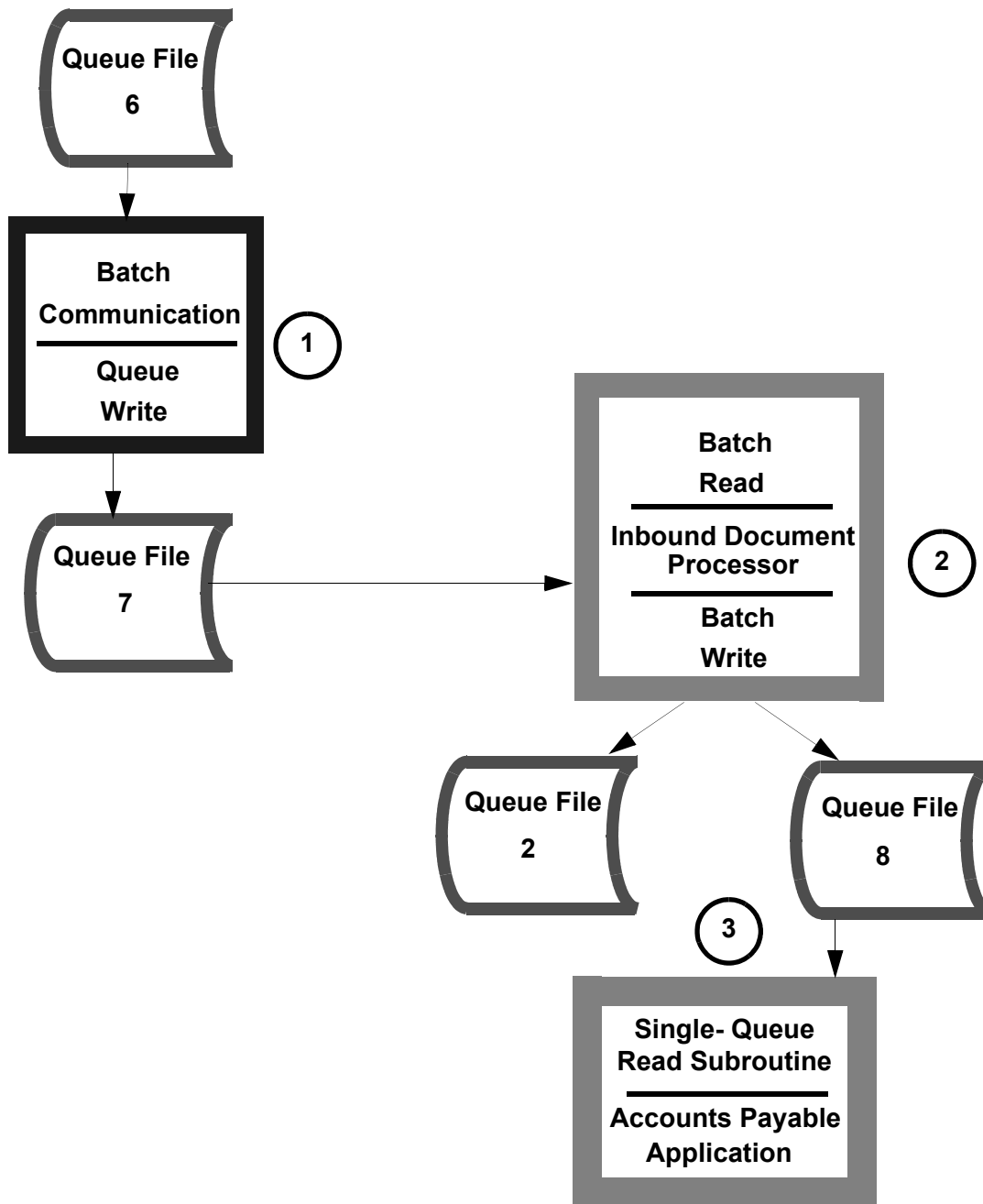

Figure 1.15 Example of System Operation – 4 of 5

The following steps describe the activity illustrated in Figure 1.15.

1. **Batch Communications Job Stream**
The presence of data in Queue File 6 triggers Gentran:Control to submit JCL for the batch communications job stream. The communications interface uses the Queue programs to read outgoing EDI data from Queue File 6 and to write incoming EDI data from communication to Queue File 7.

2. **Inbound Batch Job Stream**
The presence of EDI data on Queue File 7 triggers Gentran:Control to submit JCL for the inbound batch job stream. Control cards specify that Queue File 7 is to be processed. Control cards to the inbound Gentran job stream specify that documents for the order processing application are to be written to Queue File 2, and documents for the accounts payable application are to be written to Queue File 8.

3. **Inbound Batch Accounts Payable Job Stream**
The accounts payable application runs on a schedule. The application uses the Single Queue Read program to read data from Queue File 8.

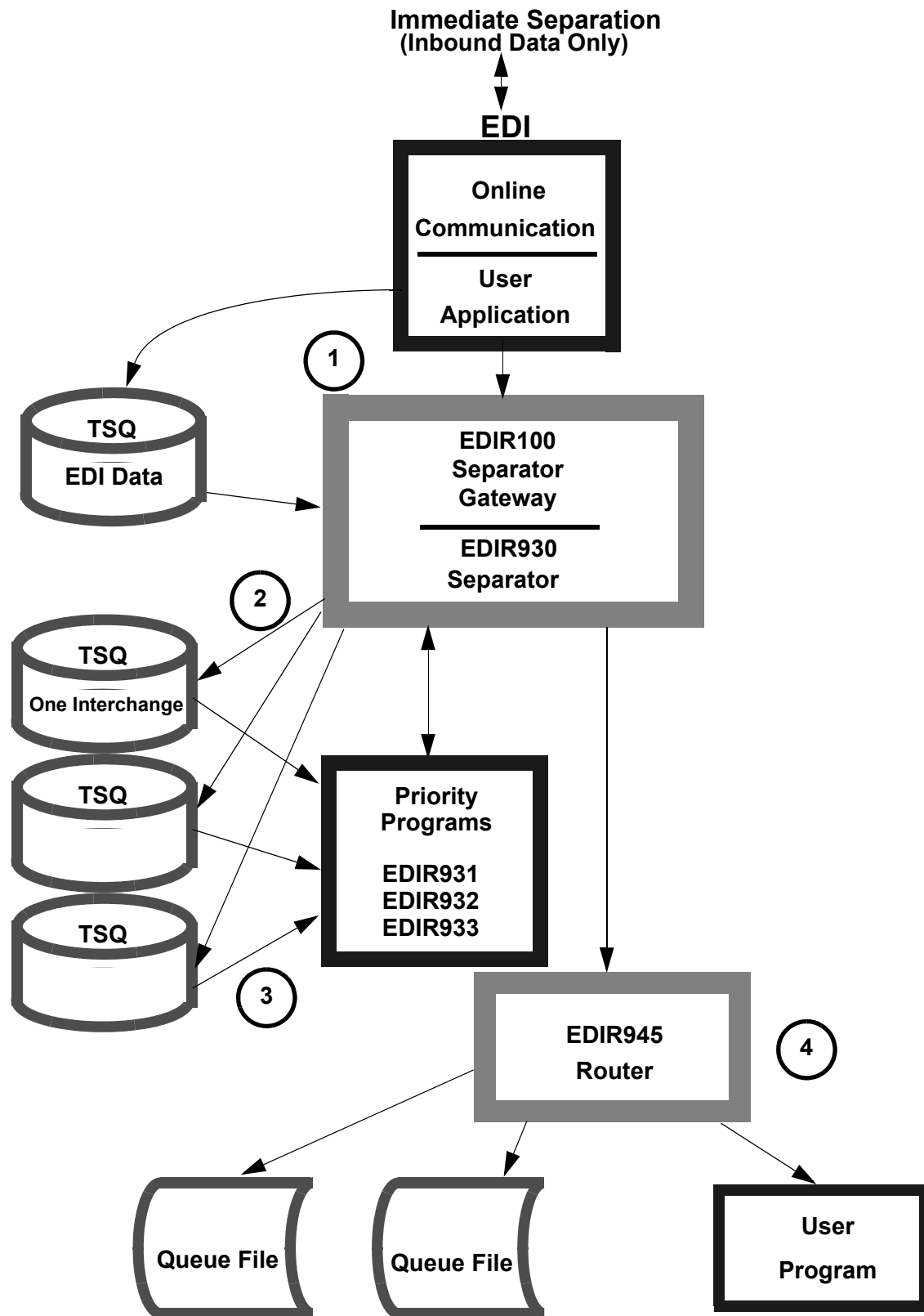

Figure 1.16 Example of System Operation – 5 of 5

The following steps describe the activity illustrated in Figure 1.16.

1. **Data Communication**
The user application retrieves data from the online communications system, writes it to a TSQ, and passes operation control to the Separator Gateway.
2. **Separation**
The Separator Gateway verifies the information and passes operation control to the Separator program. The Separator program reads the TSQ passed from the user application and writes individual TSQs for each interchange encountered.
3. **Priority Assignment**
The Separator passes operation control to the priority programs, which determine the priority assignment for each interchange and the process to be performed on each interchange. The priority programs then return operation control to the Separator program.
4. **Router Processing**
The Separator passes operation control to the Router program, which processes the individual interchanges according to their assigned priorities, passing them to queue files or to a user application.

Overview

The sections in this chapter are structured to provide you with a basic understanding of Gentran:Control. The steps are organized around the following subjects:

- Navigating the Gentran:Control screens.
- Creating a Queue file.

Note: Do not begin the procedures in the following sections unless the entire Gentran:Basic/Control system has been installed and is operational.

This chapter contains the following topics:

Topic	Page
Tutorial Screen Inconsistencies	2-2
Logging on to Gentran:Control.....	2-3
Updating Security	2-4
Navigating Gentran:Control Screens	2-8
System Options Maintenance.....	2-9
Queue Directory	2-10
Queue Options Maintenance	2-11
Online Log Display	2-12
Separator Main Menu.....	2-13
Separator Systems Options Maintenance.....	2-14
Priority Options Directory	2-15
Priority Options Maintenance	2-16
Separator Monitor	2-17
Summary	2-18
Creating a Queue File.....	2-19
Overview	2-19
Define and Format the Data Set.....	2-20
Defining the File to CICS	2-22
Defining the File to Gentran:Control	2-26
Restarting Gentran:Control	2-28

Tutorial Screen Inconsistencies

Data on sample screens in this guide will not match exactly the data that you see on your screens, for various reasons: your run date and time will be different, and the install data may have changed since this guide was printed.

When comparing screens, verify that the flow from one screen to another is correct, according to the samples provided in this guide, and that the screens appear to be complete (e.g., the PF keys are present at the bottoms of screens) and that no “garbage” data appears on the screen.

Logging on to Gentran:Control

Security starts the moment the Gentran logon screen displays. You must enter a User ID and password to gain access to the system. The figure below illustrates the Gentran logon screen.

```
EDIM000                                     12/01/2005
                                           12:00:00

      G E N T R A N

SYSTEM IMAGE: EDI      PROGRAM IMAGE: EDI      DBK CONFIG:FFFF
GENTRAN:CONTROL 6.4

      User ID: _____ Password:
                          New Password:

      ***TRADE SECRET NOTICE***
This software is the confidential and trade secret property of STERLING
COMMERCE (MID AMERICA), INC. and/or the owner of the software, and is
provided under the terms of a license agreement. No duplication or disclosure
without prior written permission. Restricted rights.

Enter                               PF3=Exit
```

You can change your password using this screen. New users should change their passwords the first time they log on. Gentran:Basic prevents users from reusing their previous passwords.

Note: TO SECURITY USERS: The security system displays menu selections for all possible Gentran:Basic features, including additional features such as Mapping Integration and Gentran:Control. Activate only those features to which you require access.

Verify that the Gentran logon screen displays the words Gentran:Control Release 6.4 in the list of available subsystems above the User ID field. If you do not see the words “Gentran:Control Release 6.4,” check the installation to verify that the Configuration file has been updated properly.

After entering your user User ID and password, proceed to the next section, “Updating Security.”

Updating Security

Step 1 Verify that security has been set up for Gentran:Control.

Typically performed by: EDI Coordinator

The tasks involved in verifying the security setup are listed below. Check the box next to each task as you complete it.

- Log on to the Gentran:Control system.

The Gentran:Basic Main Menu displays.

```

EDIM001 0.0_____      Gentran MAIN MENU          XXX      12/01/2005
EDI/EDI                  XXXXXXXX          12:00:00

Type the number of your selection below and press ENTER, or
press the PF3 key to Exit.

—  1.  Partner Maintenance Menu
    2.  Standards Maintenance Menu
    3.  Databank Maintenance Menu
    4.  Administrative Maintenance
    5.  Mapping Maintenance Menu

    6.  GENTRAN:Plus Main Menu      (N/A)
    7.  GENTRAN:Control Main Menu
    8.  GENTRAN:Realtime Main Menu  (N/A)
    9.  GENTRAN:Viewpoint Main Menu (N/A)

Enter PF1=Help          PF3=Exit

PF15=Logoff

```

- Verify that option 7 (Gentran:Control Main Menu) displays with the designation **(N/A)** next to it.

Note: If the designation **(N/A)** *does not* display with option 7 (Gentran:Control Main Menu), skip the rest of this step and proceed to **Step 4**.

- On the Gentran Main Menu, press **Home** and type **4.1** in the jump code field, then press **Enter**.

The Security Maintenance Menu displays.

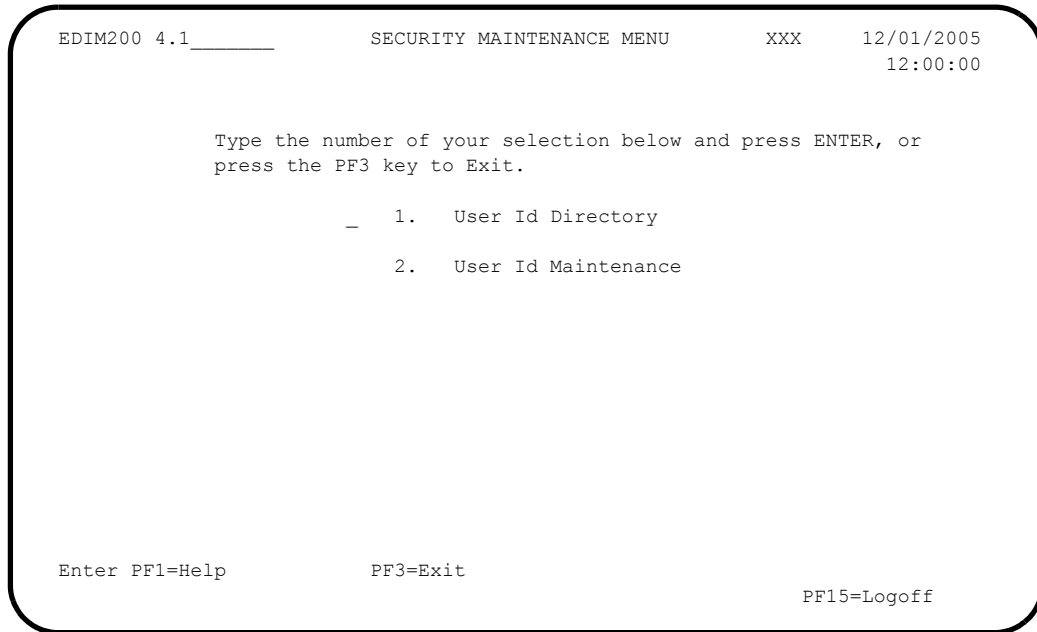

Completed by: _____

Date: _____ Time: _____

Step 2 Change Security for Gentran:Control.

Typically performed by: EDI Coordinator

The tasks involved in changing security are listed below. Check the box next to each task as you complete it.

- From the Security Maintenance Menu, select option 2 (User ID Maintenance) and press **Enter**.

The User ID Maintenance-1 screen displays.

```

EDIM201 4.1.2_____ USER ID MAINTENANCE-1          XXX   12/01/2005
                                                    12:00:00

User Id..... SMITH__ Password..          Division.. 01A  Initials.. XXXXXXXXX

Last Name.. SMITH_____ First.. JOHN_____ MI.. E

Last Update Date..:          User..:

Options                                     Access   Authority Level
Partner Maintenance                   N (Y/N)  3 (1/2/3)
Standards Maintenance                 Y (Y/N)  3 (1/2/3)
Databank Maintenance                 Y (Y/N)  3 (1/2/3/4/5/6)
Mapping Integration                   Y (Y/N)  3 (1/2/3)
Administrative Maintenance            N (Y/N)  3 (1/2/3)
  Security Maintenance                N (Y/N)  3 (1/2/3)
  Message Maintenance                 N (Y/N)  3 (1/2/3)
  Configuration File Maintenance      N (Y/N)  3 (1/2/3)
  Global Parameter Maintenance        N (Y/N)  3 (1/2/3)

Enter PF1=Help          PF3=Exit PF4=Dir          PF5=More Opts  PF6=Nxt User
                        PF9=Add PF10=Updt PF11=Del
    
```

- On the User ID Maintenance-1 screen, enter your User ID in the first field and press **Enter**.

Completed by: _____

Date: _____ **Time:** _____

Step 3 Update Security for Gentran:Control.

Note: This is a good time for you to enable update access for all personnel who will be accessing Gentran:Control.

Typically performed by: EDI Coordinator

The tasks involved in updating security are listed below. Check the box next to each task as you complete it.

- From the User ID Maintenance-1 screen, press **PF5=More Opts.**

The User ID Maintenance-2 screen displays.

```

EDIM202 _____ USER ID MAINTENANCE-2          XXX  12/01/2005
                                                    12:00:00

User Id..... SMITH

Last Update Date...: 12/01/05   User...: XXX

Options                                     Access   Authority Level
GENTRAN:Plus                               N (Y/N)  3 (1/2/3)
GENTRAN:Control                             Y (Y/N)  1 (1/2/3)
GENTRAN:Realtime                           N (Y/N)  3 (1/2/3)
Realtime Databank Maintenance              N (Y/N)  6 (1/2/3/4/5/6)
GENTRAN:Viewpoint                          N (Y/N)  4 (1/2/3/4)
      Recipient                             _____ (optional)

Enter PF1=Help          PF3=Exit PF4=Prev
                        PF10=Updt
    
```

- Change the value in the Access field for Gentran:Control from **N** to **Y**.
- Change the value in the Authority Level field to **1** then press **PF10=Update**.
- Press **Home** and type **x** in the Jump Code field to sign off Gentran:Basic/Control.
- Logon to Gentran:Control again using your User ID.

Completed by: _____

Date: _____ **Time:** _____

Navigating Gentran:Control Screens

Step 4 Display the Control Main Menu.

Typically performed by: EDI Coordinator

The task involved in displaying the menu is described below. Check the box next to the task as you complete it.

- On the Gentran Main Menu, type **7** to select the Gentran:Control Main Menu and press **Enter**.

The Control Main Menu displays.

```
EDIM300 7.0_____ CONTROL MAIN MENU          XXX   12/01/2005
                                                12:00:00

Type the number of your selection below and press ENTER, or
press the PF3 key to Exit.

      _      1.  System Options Maintenance
              2.  Queue Directory
              3.  Queue Options Maintenance
              4.  Online Log Display
              5.  Separator Menu

Enter PF1=Help          PF3=Exit

                                                PF15=Logoff
```

Completed by: _____

Date: _____ **Time:** _____

System Options Maintenance

The System Options Maintenance screen is the primary screen used to control processing by the Online Scanner/Initiator program (EDIEOSI). EDIEOSI is the driver program for all online processing in Gentran:Control. You will enter options on the System Options Maintenance screen to direct processing by the program.

Step 5 Display the System Options Maintenance screen.

Typically performed by: EDI Coordinator

The task involved in displaying the screen is described below. Check the box next to the task as you complete it.

- From the Control Main Menu, type **1** to select System Options Maintenance and press **Enter**.

The System Options Maintenance screen displays.

```

EDIM301 7.1 _____ SYSTEM OPTIONS MAINTENANCE          XXX 12/01/2005
                                                                12:00:00

Description.....: GENTRAN:CONTROL _____
                  SAMPLE_SYSTEM_OPTIONS _____

System Status.....: E      E = Enabled          D = Disabled
System Trace.....: D      E = Enabled          D = Disabled
System Type.....:  C      C = Control           R = Realtime

Scan Interval.....: 0120      Seconds

Error User Exit Program.: _____
Error User Exit Data....: _____

Last Update Date.....: 00/00/00  Time: 00:00:00  User: SCI

Enter PF1=Help          PF3=Exit          PF5=Queue
                        PF10=Updt         PF13=Start
    
```

Completed by: _____

Date: _____ **Time:** _____

Queue Directory

The Queue Directory screen displays a concise list of the Queue files within Gentran:Control. The Status, Init Act, and JCL/Trans fields display key information about what actions will be taken with the data on a Queue file.

The value in the # of Docs field can be used to track processing because as data is being written to and read from the Queue files, the field updates each time you press **Enter**.

Step 6 Display the Queue Directory screen.

Typically performed by: EDI Coordinator

The task involved in displaying the screen is described below. Check the box next to the task as you complete it.

- On the System Options Maintenance screen, press **PF5=Queue**.

The Queue Directory screen displays.

```

Select
EDIM302 7.2_____          QUEUE DIRECTORY          XXX 12/01/2005
                                                12:00:00

Starting Queue File Number:  ____

A Queue  Description
- 001 CONTROL INSTALLATION VERIFICATION          # of
- 002 CONTROL INSTALLATION VERIFICATION          Docs Stat Src Act Trans
- 003 CONTROL INSTALLATION VERIFICATION          1   E   O   B   OBX
- 004 CONTROL INSTALLATION VERIFICATION          0   E   B   O   EDIR
- 005 CONTROL INSTALLATION VERIFICATION          1   E   B   B   IBX
- 006 CONTROL INSTALLATION VERIFICATION          0   E   B   O   EDIR
-
-
-
-
-
-

Enter PF1=Help PF2=Data PF3=Exit PF4=SysOpts PF5=Maint PF6=Ddt1
      PF7=Bwd  PF8=Fwd
    
```

Completed by: _____

Date: _____ **Time:** _____

Queue Options Maintenance

The Queue Options Maintenance screen is the primary screen used to control the processing and flow of Gentran:Control Queue files. The values you enter on this screen provide the following information for Gentran:Control:

- The source of input data for the Queue file
- When the data should be processed (according to the trigger levels you set)
- How the data will be processed (according to the initiation action you indicate; e.g., batch job, online task, or none)

Step 7 Display the Queue Options Maintenance screen.

Typically performed by: EDI Coordinator

The task involved in displaying the screen is described below. Check the box next to the task as you complete it.

- From the Queue Directory screen, type an **s** in the A (Action Code) field to the left of any Queue file listed, and press **PF5=Maint**.

The Queue Options Maintenance screen displays.

```

EDIM303 7.3 _____ QUEUE OPTIONS MAINTENANCE XXX 12/01/2005
                                                    12:00:00

Queue File Number.....: 001      GENTRAN:CONTROL_INSTALLATION_TEST_____
                               QUEUE_FILE_001_____
Status.....: E      E=Enabled D=Disabled
Source.....: O      O=Online write B=Batch write
Trace.....: D      E=Enabled D=Disabled
      Trigger Levels      Queue Priority.....: 1 (Value 1-9)
Range (Low/High).....: 0000 / 0001 Doc Groups per Run...: 0001
Maximum Delay Time...: 0000      Minutes (with Low Range)
Time Based Interval...: 0000      EXT or SCH or Minutes
      Initiation Actions
Action to Initiate....: B      B=Batch Job O=Online Trans N=None
Batch JCL Name.....: OB_      Stall Limit.....: 15
Online TransID.....: _____ Appl.Prog.....: _____
Exception Pgm.....: _____ TSQ Store Sw.....: _ A=Auxiliary M=Main
                                                    C=TSQ Chaining

Error User Exit Pgm...: _____ Error Exit Data.: _____
                        Last Update Date: 00/00/00 Time: 00:00:00 User: SCI

Enter PF1=Help PF2=Data PF3=Exit PF4=Dir PF5=Ext
      PF7=Prev PF8=Next PF9=Add PF10=Updt PF11=Del PF14=Ddt1
    
```

Completed by: _____

Date: _____ **Time:** _____

Online Log Display

Many transactions within Gentran:Control processing take place in background (e.g., without a terminal display). To enable you to view the status of the transactions, the Online Log file holds error and information messages that are created during these background processes. The Online Log Display is the primary screen used to view the messages on the Online Log file.

Step 8 Display the Online Log Display screen.

Typically performed by: EDI Coordinator

The task involved in displaying the screen is described below. Check the box next to the task as you complete it.

- From the Queue Options Maintenance screen, use the jump code feature to exit to the Online Log Display screen, by pressing **Home** and typing **7.4** in the Jump Code field, then pressing **Enter**.

The Online Log Display screen displays.

```

Select
EDIM304 7.4_____ ONLINE LOG DISPLAY          XXX   12/01/2005
                                           12:00:00
Start: 12/01/2005 12:00:00 Stop:           Last: 12:00:00 Scan: 0030
Filters====> Errors Only: _  Program Only: _____
Position      Task #      TranID      Time      Date      Max Count
Criteria====> _____      _____      _____      _____      _____      0450

A   Task   Tran   Time   Date   Term   Program   Error Code
-   00307  EDIB  12:00:00  12/01/2005  EDIEOBI  EDI-10405-W 04
    POSSIBLE BATCH STALL DETECTED, JOB SUBMISSION BYPASSED: 014 STALL CNT: 6
-   00309  EDIB  12:00:00  12/01/2005  EDIEOBI  EDI-10405-W 04
    POSSIBLE BATCH STALL DETECTED, JOB SUBMISSION BYPASSED: 014 STALL CNT: 7
-   00311  EDIB  12:00:00  12/01/2005  EDIEOBI  EDI-10405-W 04
    POSSIBLE BATCH STALL DETECTED, JOB SUBMISSION BYPASSED: 014 STALL CNT: 8
-   00313  EDIB  12:00:00  12/01/2005  EDIEOBI  EDI-10405-W 04
    POSSIBLE BATCH STALL DETECTED, JOB SUBMISSION BYPASSED: 014 STALL CNT: 9
-   00368  EDI   12:00:00  12/01/2005  TS01   NO NAME   EDI-10006-F 16
    ERROR READING FILE: EDIQM14, EIBRCODE: 01==> DSIDERR, EIBFN: 0602==> READ
-   00371  EDI   12:00:00  12/01/2005  TS01   NO NAME   EDI-10006-F 16
    ERROR READING FILE: EDIQM14, EIBRCODE: 01==> DSIDERR, EIBFN: 0602==> READ

Enter PF1=Help          PF3=Exit          PF5=Action
      PF7=Bwd   PF8=Fwd
    
```

Completed by: _____

Date: _____ **Time:** _____

Separator Main Menu

The Separator Main Menu displays all sub functions available in the Separator subsystem.

Step 9 Display the Separator Main Menu.

Typically performed by: EDI Coordinator

The task involved in displaying the screen is described below. Check the box next to the task as you complete it.

- From the Online Log Display screen, use the jump code feature to exit to the Separator Main Menu by pressing **Home** and typing **7.5** in the Jump Code field, then pressing **Enter**.

The Separator Main Menu screen displays.

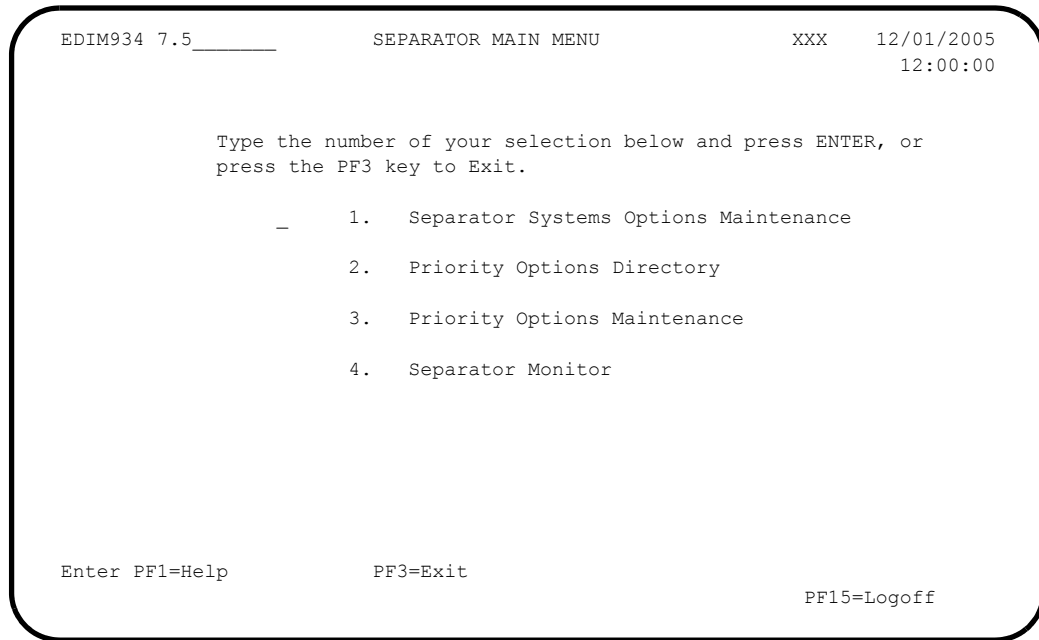

Completed by: _____

Date: _____ **Time:** _____

Separator Systems Options Maintenance

The Separator Systems Options Maintenance screen is the primary screen used to control processing by the Separator program (EDIR930). This screen enables you to display and update the Separator Systems Options record, which is located in the Separator Control file (EDIRSEP).

The options you enter on the Separator System Options Maintenance screen tell the Separator which priority lookup programs to use for processing different types of interchanges (e.g., X12, EDIFACT, etc.), as well as any special parameters to use in the priority lookup programs (such as key indicators), and how to handle errors.

Step 10 Display the Separator System Options Maintenance screen.

Typically performed by: EDI Coordinator

The task involved in displaying the screen is described below. Check the box next to the task as you complete it.

- From the Separator Main Menu, select option 1 (Separator System Options Maintenance) and press **Enter**.

The Separator System Options Maintenance screen displays.

```

EDIM935 7.5.1_____ SEPARATOR SYSTEMS OPTIONS MAINTENANCE   XXX 12/01/2005
                                                                12:00:00

Description.....: GENTRAN:CONTROL_SEPARATOR_SUBSYSTEM_____

X12 Interchange Program .....: EDIR931_   Key Usage Indicators
EDIFACT Interchange Program.....: EDIR932_   Test/Prod Use.....: Y
TRADACOMS Interchange Program.....: EDIR933_   Trn/Grp/Int Only...: T
User Interchange Program.....: EDISXIT_   Grp IDs Only.....: Y
Monitor Indicator/Store Sw.....: 1 / 1     Sndr/Rcvr Id Only.: Y
  Monitor Maintenance.....(630)...: _   DELETE PROCESSED DATA < TODAY'S DATE
  .....(631)...: _   DELETE ALL DATA < TODAY'S DATE
  .....(632)...: _   DELETE ALL DATA RECORDS
Trace Indicator.....: D           Router Parameters
Exception Program.....: EDIR852_   Max Start cnt.....: 10
TSQ Storage SW.....: M           Max Wait Time.....: 00 05

Error User Exit Program.....: _____
Error User Exit Data.....: _____

Last Update Date: 12/01/05 Time: 12:00:00 User: XXX

Enter PF1=Help           PF3=Exit PF4=Run Maint  PF5=Dir
                          PF10=Uprt
    
```

Completed by: _____

Date: _____ **Time:** _____

Priority Options Directory

The Priority Options Directory screen enables you to view the records used by the interchange priority lookup programs. The data for this screen is located on the Separator Control file (EDIRSEP).

Step 11 Display the Priority Options Directory.

Typically performed by: EDI Coordinator

The task involved in displaying the screen is described below. Check the box next to the task as you complete it.

- From the Separator Systems Options Maintenance screen, press **PF5=Dir**.

The Priority Options Directory screen displays.

```

Select
EDIM936 7.5.2_____ PRIORITY OPTIONS DIRECTORY XXX 12/01/2005
                                                    12:00:00

Starting Trans/Group id....: _____

A Trans/  Sender ID          Qual  Version  Test I/G/T
  Group  Receiver ID        Qual  Description  Prod  Ind
-
-          DELHDR          -          -          -          -          -          -          -          -
-          INVOIC          -          -          -          -          -          -          -          -
-          810             -          -          -          -          -          -          -          -
-
-          X12 810 TEST DATA

Enter PF1=Help          PF3=Exit PF4=Option    PF5=Maint
      PF7=Bwd   PF8=Fwd
    
```

Completed by: _____

Date: _____ **Time:** _____

Priority Options Maintenance

The Priority Options Maintenance screen enables you to enter the parameters used by the interchange priority lookup programs to identify the processing characteristics for a given set of data. The records are located in the Separator Control file (EDIRSEP).

Step 12 Display the Priority Options Maintenance screen.

Typically performed by: EDI Coordinator

The task involved in displaying the screen is described below. Check the box next to the task as you complete it.

- On the Priority Options Directory screen, type an **S** in the A (Action Code) field to the left of the Trans/Group entry **INVOIC** and press **PF5=Maint**.

The Priority Options Maintenance screen displays.

```

EDIM937 7.5.3_____ PRIORITY OPTIONS MAINTENANCE XXX 12/01/2005
                                                    12:00:00

** K E Y S **
Trans/Group ID.....: INVOIC
Sender ID / Qual.....: _____ / ____
Receiver ID / Qual....: _____ / ____
Version.....: _____
Test/Prod Ind.....: T
Int/Grp/Trans Ind.....: T

Description.....: EDIFACT_INVOIC_TEST_DATA_____

System Image...: EDI Program Image...: EDI
Realtime Immediate Option.....: _____
Queue File Number.....: 005 CONTROL INSTALLATION VERIF
User Application Program.....: _____
Basic Separator Split file.....: 003
Priority.....: 5
Last Update Date: 00/00/00 Time: 00:00:00 User: SCI

Enter PF1=Help PF3=Exit PF4=Dir PF5=QOpt
PF7=Bwd PF8=Fwd PF9=Add PF10=Updt PF11=Del
    
```

Completed by: _____

Date: _____ **Time:** _____

Separator Monitor

The Separator Monitor screen enables you to view the entries in the Monitor Header file (EDIRMNH) and the first record for each entry in the Monitor Store file (EDIRMNS).

Step 13 Display the Separator Monitor screen.

Typically performed by: EDI Coordinator

The task involved in displaying the screen is described below. Check the box next to the task as you complete it.

- From the Priority Options Maintenance screen, type **7.5.4** in the Jump Code field and press **Enter**.

The Separator Monitor screen displays.

```

EDIM938 7.5.4_____ SEPARATOR MONITOR XXX 12/01/2005
                                           12:00:00

Date...: _____ Time...: _____

Date      Time      Task #   Opt  User Pgm  Prty  Error Stat  Desc
First Record
20010927  12340100  0000034  005           5    08  08  DEFAULT SEPARAT
NO DATA AVAILABLE
20010927  12340100  0000034  003           5    16  06  USER SUPPLIED I
NO DATA AVAILABLE
20010927  12340100  0000034  003           5    16  06  USER SUPPLIED I
NO DATA AVAILABLE
20010927  12340100  0000034  005           5    08  08  DEFAULT SEPARAT
NO DATA AVAILABLE
20010927  12340100  0000034  005           5    08  08  USER SUPPLIED I
NO DATA AVAILABLE
20010927  12340100  0000034  010           3    01  01  TRADACOMS DELHD
NO DATA AVAILABLE

Enter PF1=Help           PF3=Exit
      PF7=Bwd  PF8=Fwd
    
```

Completed by: _____

Date: _____ **Time:** _____

Summary

You have navigated the primary Gentran:Control screens. The screens that are not included in the section you have just completed are support screens for the Queue Options Maintenance screen or the Online Log Display screen.

Chapter 3 of this manual contains reference information for all the screens that can be accessed within Gentran:Control.

The rest of this chapter is organized to lead you through the major functions of Gentran:Control in a step-by-step fashion.

Creating a Queue File

All processes within Gentran:Control revolve around the use of Queue files. Queue files are VSAM RRDS (relative record data sets), created with a primary space allocation only (they have no secondary allocation, therefore no space is available for growth).

Queue files must be formatted before they can be used by Gentran:Control for processing. The formatting procedure consists of two parts: writing empty records throughout the space allocated for the data set, and initializing the first two records with control information. During processing, Queue files process in a wrap-around fashion (e.g., when the end of the file is reached, the system continues processing back at the top of the file). This wrap-around process is enabled by the formatting of the first two records in the file.

See “System Operation” in Chapter 1, “Getting Started,” in this guide for more information about the Gentran:Control Queue facility.

Overview

The steps in this section lead you through the processes required to set up a Queue file, as explained in the following list.

1. Define and format the data set. This can be accomplished by running the JCL in member EXECQMT).
2. Define the file to CICS.

Note: The Queue file number used in Steps 1 and 2 must be used in the Resource definition file name. For example, if the file is defined as Queue file 009, then EDIQ009 must be defined as the file name for that data set.

3. Define the file to Gentran:Control. This involves adding the control parameters through the Queue Options Maintenance screen (EDIM303) that define the Queue file. (Specific parameters are explained in later sections of this chapter.)
4. Restart the Gentran:Control system by entering EDII on a CICS terminal.

Define and Format the Data Set

In this step, you will create the Queue file to format it for use with Gentran:Control. The Queue file passes data from an online application to a batch translation.

Step 1 Define and format the data set.

Typically performed by: EDI Coordinator

The task involved in completing the step is described below. Check the box next to the task as you complete it.

- Create Queue file 009 by running the JCL in EXECQMT, as illustrated in the following example.

Note: The NUMBERED, RECORDSIZE and SHR parameters are required to set up the Queue file correctly.

```
//DEFINE EXEC PGM=IDCAMS
//SYSPRINT DD SYSOUT=*
//SYSIN DD *
/* QUEUE FILE 009 */
/* MUST NOT HAVE SECONDARY SPACE ALLOCATION */
DELETE GENTRAN.V6X4.CTL.VSAM.EDIQ009 CLUSTER PURGE
DEFINE CLUSTER (NAME (GENTRAN.V6X4.CTL.VSAM.EDIQ009) -
          VOLUME (XXXXXX) -
          RECORDS (800) -
          NUMBERED -
          RECORDSIZE (4088 4088) -
          SHR (4 3) -
          DATA (NAME (GENTRAN.V6X4.CTL.VSAM.EDIQ009.DATA) -
                CISZ (4096)
```

- The Queue file number is 009 and 000000800 agrees with the Records field in the IDCAMS Define.

Note: This step is executed by EXECQMT.

```
//*
//*      INITIALIZE QUEUE FILE 009
//*
//EDIEQMT EXEC PGM=EDIEQMT, REGION=700K, TIME=9
//STEPLIB DD DSN=GENTRAN.V6X4.CTL.BATCH.LOAD,DISP=SHR
//        DD DSN=GENTRAN.V6X4.BATCH.LOAD,DISP=SHR
//EDICFG  DD DSN=GENTRAN.V6X4.VSAM.EDI.EDICFG,
//        DISP=SHR
//ERRCTL  DD DSN=GENTRAN.V6X4.VSAM.ERRCTL,
//        DISP=SHR
//EDICKP  DD DSN=GENTRAN.V6X4.CTL.VSAM.EDICKP,
//        DISP=SHR
//EDIQF   DD DSN=GENTRAN.V6X4.CTL.VSAM.EDIQ009,DISP=SHR,UNIT=DISK
//EDISUM  DD SYSOUT=*
//EDILOG  DD SYSOUT=*
//EDIRPT  DD SYSOUT=*
//EDIRLB  DD SYSOUT=*
//SYSUDUMP DD SYSOUT=*
//EDICNTL DD *
FORMAT
        QUEUE-FILE-NUMBER                009 000000800
```

Completed by: _____

Date: _____ **Time:** _____

Defining the File to CICS

In these steps, you define Queue file 009 to CICS.

Step 2 Define the file to CICS.

Typically performed by: Systems Programmer or CICS Administrator

The task involved in defining the file is described below. Check the box next to the task as you complete it.

- Review the definition for your site requirements.
- Add the following entry to your CICS file resource definition JCL member **CTLRDOF**.
- Change the value **SIM** to your three-character system image.
- The definition contains the **DSNAME** parameter to specify the name of the data set to be allocated for the file. You may remove this parameter and instead specify the file using a DD statement in the CICS startup JCL.

If you elect to retain the **DSNAME** parameter, you must change the data set name high-level qualifier **GENTRAN.V6X4** to the value you are using.

- If you changed the CICS Group Name from the default value **GENCTL**, change the value in the **GROUP** parameter to the value you are using.
- Review Local Shared Resource Pool Ids for your system. Files that cannot be installed in a LSR pool use the parameter **LSRPOOLID (NONE)** in the definition.
- If you are installing into an MRO environment, you will need to uncomment the **KEYLENGTH** and **RECORDSIZE** parameters for the resource definition.

You may also need to uncomment the **REMOTESYSTEM (NAME)** parameter and change the value **NAME** to the 4-character alphanumeric name of the CICS region where the files reside.

In addition, if you are creating a unique group name for each MRO region, you will need to create a duplicate definition for each unique group name.

- Read the comments within the JCL member and follow additional instructions.

```
*
* QUEUE FILE 009 -
*
DEFINE FILE(SIMQ009)
  GROUP(GENCTL)
  DESC(CONTROL QUEUE 009 FILE)
  DSNNAME(GENTRAN.V6X4.CTL.VSAM.EDIQ009)
  LSRPOOLID(NONE)
  STRINGS(3)
  RECORDFORMAT(F)
  ADD(NO)
  BROWSE(NO)
  DELETE(NO)
  READ(YES)
  UPDATE(YES)
*
  KEYLENGTH(4)
*
  RECORDSIZE(4088)
*
  REMOTESYSTEM(NAME)
*
```

Completed by: _____

Date: _____ Time: _____

Step 3 Add the file to the CICS system definition file.

Customize JCL member **DEFRDO**.

Typically performed by: Systems Programmer or CICS Administrator

Check the box next to the task as you complete it.

- Add a Job Card.
- Change data set names **YOUR.CICS.SDFHLOAD** and **YOUR.CICS.DFHCS** as required by your installation.
- Change the data set names as required by your installation. Change only the first two index levels (**GENTRAN.V6X4**).
- If you changed the CICS Group Name from the default value **GENCTL**, substitute your group name in the **DELETE** step in the JCL.
- If you are defining the file in an existing group, you must comment out or remove the **DELETE** step in the JCL. Otherwise, your existing group will be deleted.
- If you are installing into an MRO environment, you may need to run this job multiple times depending on whether or not you are sharing the CSD file among the regions and whether or not you are using different group names in each region. If you do need to run the DEFRDO job multiple times, modify the CSD file name, group name, and/or JCL member names to meet your needs.
- Read the comments within the JCL member and follow additional instructions.
- Submit the JCL member.
- Verify the job results. You should never receive a return code greater than 0.

Completed by: _____

Date: _____ **Time:** _____

Step 4 Install (activate) the Gentran:Control CICS groups

Note: If you changed the group names, substitute your group names when using the CEDA command.

This step requires the use of the CEDA master transaction.

Check your CICS concatenation list in your CICS startup deck. If necessary, add the Gentran:Control CICS load library to the list.

Typically performed by: Systems Programmer or CICS Administrator

Check the box next to the task as you complete it.

- Start up the CICS application.
- Log on to CICS as required within your environment to access the CEDA transaction. When you have finished, clear the screen.
- Type the following command:

CEDA INSTALL GROUP (GENCTL)
- Check for the **Install Successful** results from CEDA. When you have finished, press **PF3** and then clear the screen.

Completed by: _____

Date: _____ **Time:** _____

Defining the File to Gentran:Control

In this step, you will add queue information on the Queue Options Maintenance (EDIM303) screen as if you were setting up a Queue file to submit a batch job (in this case, JCL in file EDIJ009) when data is placed on the Queue file from an online transaction (indicated by the O value entered in the Source field).

You must set the trigger level so that processing begins as soon as the Online Scanner/Initiator finds one document on the Queue file.

Note: The file must be defined in the CICS region before you can complete this screen.

Step 5 Enter information about new Queue file on the Queue Options Maintenance screen.

Typically performed by: EDI Coordinator

The tasks involved in entering the information are listed below. Check the box next to each task as you complete it.

- From the Queue Directory screen, type an **s** in the A (Action Code) field to the left of any Queue File listed and press **PF5=Maint**.

OR

Enter jump code **7.3** and press **Enter**.

- Fill in the required information as follows:

Field	Enter this
Queue File number (description)	009 Test Queue – online to online ODD # Q
Status	E
Source	O
Trace	D
Range (Low)	0000
Range (High)	0001
Queue Priority	5
Docgroups per run	0001
Maximum Delay Time	0000
Time Based Interval	0000
Action to Initiate	B
Batch JCL name	009
Stall Limit	15

- Press **PF9** to add the queue information.
- Verify that the completed screen appears.

```

EDIM303 7.3_____  QUEUE OPTIONS MAINTENANCE  XXX 12/01/2005
                                                    12:00:00

Queue File Number.....: 009          TEST_QUEUE_-_ONLINE_TO_ONLINE_ODD#Q_____
Status.....: E                      E=Enabled D=Disabled
Source.....: O                      O=Online write B=Batch write
Trace.....: D                      E=Enabled D=Disabled
      Trigger Levels
Range (Low/High).....: 0000 / 0001   Queue Priority.....: 5 (Value 1-9)
Maximum Delay Time...: 0000         Doc Groups per Run...: 0001
Time Based Interval...: 0000        Minutes (with Low Range)
      Initiation Actions
Action to Initiate....: B           B=Batch Job O=Online Trans N=None
Batch JCL Name.....: 009           Stall Limit.....: 15
Online TransID.....: _____   Appl.Prog.....: _____
Exception Pgm.....: _____    TSQ Store Sw....: _ A=Auxiliary M=Main
                                                    C=TSQ Chaining

Error User Exit Pgm...: _____   Error Exit Data.: _____
                        Last Update Date: 00/00/00 Time: 00:00:00 User: SCI

Enter PF1=Help PF2=Data PF3=Exit PF4=Dir PF5=Ext
      PF7=Prev PF8=Next PF9=Add PF10=Updt PF11=Del PF14=Ddt1
    
```

Completed by: _____

Date: _____ Time: _____

Restarting Gentran:Control

Completing this step makes the new Queue file available for processing.

Step 6 Restart the Gentran:Control system.

Typically performed by: EDI Coordinator

The task involved in restarting the system is described below. Check the box next to the task as you complete it.

- Type **EDII** on a CICS terminal. The Online Scanner/Initiator program reinitializes the system and identifies the new Queue file as available for processing.

Completed by: _____

Date: _____ **Time:** _____

This concludes the Gentran:Control Tutorial.

Overview

This chapter contains the reference information you need to use the Gentran:Control for zSeries Release 6.4 system. The chapter is divided into sections, each of which is comprised of all reference information relating to a particular screen. In each section you will find the following reference information:

- The purpose of the screen
- Instructions on how to access the screen
- An example of the screen
- Descriptions of screen actions, when applicable
- A list of the valid function keys for the screen, as well as descriptions of each key
- A list of the fields on the screen, as well as descriptions of those fields and valid values for each field

See Chapter 1 of the *Gentran:Basic for zSeries Release 6.4 User's Guide* for an explanation of log-on procedures and common program function key definitions.

This chapter contains the following sections:

Topic	Page
Jump Codes	3-2
Control Main MenuEDIM300	3-6
System Options Maintenance ScreenEDIM301	3-8
Queue Directory Screen.....EDIM302	3-12
Queue Options Maintenance Screen.....EDIM303	3-16
Online Log Display Screen.....EDIM304	3-25
Extended Queue Options Maintenance ScreenEDIM305	3-31
Queue Options Debug Detail Screen.....EDIM306	3-34
Queue Options Data Display ScreenEDIM307	3-44
Online Log Detailed Display Screen.....EDIM308	3-46
Separator Main MenuEDIM934	3-50
Separator Systems Options Maintenance ScreenEDIM935	3-52
Priority Options Directory Screen.....EDIM936	3-59
Priority Options Maintenance Screen.....EDIM937	3-62
Separator Monitor Screen.....EDIM938	3-66

Jump Codes

A jump code is a 10-character alphanumeric field located at the upper left corner of each Gentran screen. This field enables you to move, or *jump*, directly from one screen to another while bypassing menus. All screens that are accessible via a Gentran menu have jump code values associated with them. Screens that are accessible only from detail screens do not have jump code values associated with them.

Jumping Between Screens

In the Gentran:Basic/Control system, you can jump between screens without navigating via Gentran menus. Use the following procedure to jump between screens:

1. Press **Home**.

The cursor moves to the Jump Code field at the top of the screen, to the right of the screen name.

2. Type the jump code and press **Enter**.

For a complete list of Gentran:Control jump codes and their associated screens, see Appendix A of this guide. For a complete list of *Gentran:Basic* jump codes, see Appendix A of the *Gentran:Basic User's Guide*.

Some of the terms and definitions used in this discussion are explained in the following list:

Term	Meaning
Subsystem	A set of functionally-related screens that are directly accessible from the Gentran Main Menu (e.g., Gentran:Control Main Menu, Partner Maintenance, Standards Maintenance, Databank Maintenance, Security Maintenance, Mapping Maintenance).
Navigation	The movement from screen to screen by entering data then pressing function keys (e.g., PF1 , PF2) or by selecting options on menus and pressing Enter .
Position	The location within a subsystem file (or group of files) that displays the data (either one record or multiple records) on the screen.

Types of Jump Codes

The three types of jump codes are:

- Numeric
- Alphabetic
- Special Character

The types of jump codes are described more fully in the paragraphs that follow.

Numeric Jump Codes

Numeric jump codes consist of numbers separated by periods (.). The numbers in the jump code correspond to the numbers selected on menus, in the order in which they are selected.

Example: To display the System Options Maintenance screen, you can navigate using the Gentran menus by performing the following steps:

1. Type **7** on the Gentran Main Menu, and press **Enter**.
2. Type **1** on the Control Main Menu, and press **Enter**.

... **OR** you could jump directly to the System options Maintenance screen by performing these steps:

1. Press **Home**.
2. Type **7.1** in the Jump Code field of any screen, and press **Enter**.

For a complete list of Gentran:Control jump codes and their associated screens, see Appendix A of this guide.

Alphabetic Jump Codes

Alphabetic jump codes consist of alphabetic characters separated by periods (.). The alphabetic code is an abbreviated reference to the screen name or function. For example, to display the System Options Maintenance screen using the alphabetic jump code, type **CNTL.SOPT** in the Jump Code field of any screen, and press **Enter**.

For a complete list of Gentran:Control jump codes and their associated screens, see Appendix A of this guide.

Special Character Jump Codes

Special character jump codes enable you to perform standard or generic functions with jump codes. The two special character jump codes are SWAP and EXIT.

- SWAP enables you to jump *between* Gentran online subsystems, not *within* subsystems. When you use jump code SWAP, you jump to the last screen you *jumped from* (but not *navigated from*), from another subsystem. When you jump from a different subsystem, you reset the SWAP positioning to the screen you are jumping from.

Example: You are on the Group Information screen in the Partner subsystem, then you *navigate* to the Transaction Information screen (also in the Partner subsystem). From here, you *jump* to the Name and Address screen (again, in the Partner subsystem). Next, you *jump* to the Queue Directory screen in the Gentran:Control subsystem. After you view the information on the Queue Directory screen, type **SWAP** in the Jump Code field to return to your previous location in the Partner subsystem. SWAP returns you to the Name and Address screen in the Partner subsystem.

- EXIT (or X) in the Jump Code field enables you to jump to the system sign-off screen. In this way, you can exit the system quickly and easily from any screen.

User-Defined Jump Code Table

The User-Defined Jump Code table is a user customization facility that enables you to define your own jump code values. This facility requires a table that consists of the 10-character user code and the 10-character Gentran jump code. It must be coded in an Assembler table and the name of the table must be entered on the Configuration file (Record Type 0). An entry for the table name must be added to your CICS resource definitions.

When you type a jump code, the system verifies that the jump code you typed is valid by checking the User-Defined Jump Code table first. If you have not defined a User-Defined Jump Code table, or if the jump code you entered is not in that table, then the system checks the Default Jump Code table.

For help using the User-Defined Jump Code Table, refer to *Installing Gentran:Basic* in the *Gentran:Basic for zSeries Release 6.4 Installation Guide*. Also see member EDIJUMP in the GENTRAN.V6X4.UTILITY.SOURCE library.

Jump Code Guidelines

Gentran:Basic keeps independent position information for each subsystem and add-on product, including the Partner, Standards, Databank, Security, and Mapping subsystems and the Gentran:Plus, Gentran:Control, Gentran:Realtime, and Gentran:Viewpoint. The independence of these subsystems enables you to jump or navigate from subsystem to subsystem without having to re-type a key for that screen.

The general rules for using jump codes are:

- You can only *jump to* screens that are directly accessible through selecting menu options.
- You can *jump from* any screen.
- Navigating or jumping to the Gentran Copyright/Signon screen or exiting the Gentran system clears the positions for all subsystems.
- After you *jump from* a subsystem to another subsystem, you can return directly to the screen you *jumped from* by typing **SWAP** in the Jump Code field.
- You cannot use SWAP to jump between screens within the same subsystem.
- Typing **SWAP** is the only method by which you can *jump to* a screen that has no jump code associated with it, as long as SWAP positioning has been established by jumping from one subsystem screen to a different subsystem screen.
- An invalid jump code causes the system to return to the *jumped from* screen and display the message **INVALID JUMP CODE ENTERED**.
- You cannot *jump to* subsystems that are not installed or for which you do not have security access. The message **INVALID JUMP -- USER LACKS AUTHORITY** will be displayed on the current screen if you try.
- If you have typed in invalid jump code, you can redisplay the screen's original jump code by erasing the invalid jump code you typed and pressing **Enter**.

Control Main Menu

EDIM300

Purpose

The Control Main Menu displays all the functions available to maintain system- and queue-level parameters.

Note: Gentran:Control system maintenance functions normally are used by individuals responsible for the setup and operation of the system. These individuals should be familiar with Gentran:Basic, Gentran:Control, and CICS concepts.

How to Access

You can access the Control Main Menu in either of the following ways:

- From the Gentran:Basic Main Menu, type **7** to select the Gentran:Control Main Menu and press **Enter**.
- Type **7.0** in the Jump Code field of any screen and press **Enter**.

Screen Example

The following screen illustrates the Control Main Menu.

```
EDIM300 7.0 _____ CONTROL MAIN MENU XXX 12/01/2005
                                                    12:00:00

Type the number of your selection below and press ENTER, or
press the PF3 key to Exit.

_      1. System Options Maintenance
       2. Queue Directory
       3. Queue Options Maintenance
       4. Online Log Display
       5. Separator Menu

Enter PF1=Help          PF3=Exit
                                                    PF15=Logoff
```

The Control Main Menu contains five menu options, which enable you to perform various system setup and maintenance functions. The list of menu options, as well as a brief description of each option, follows:

Menu Option		Description
1.	System Options Maintenance	Enables you to view or update system-level parameters in the Online Control file.
2.	Queue Directory	Enables you to view the Queue files defined in the Online Control file.
3.	Queue Options Maintenance	Enables you to update queue-level parameters in the Online Control file.
4.	Online Log Display	Enables you monitor system status and error and activity history.
5.	Separator Menu	Enables you to control and monitor the Separator subsystem.

Function Key Descriptions

Note: Standard function keys, such as **PF1=Help**, **PF3=Exit**, **PF7=Bwd**, **PF8=Fwd**, **PF12=Cancel**, and **PF15=Logoff**, are defined in the Getting Started chapter of this guide.

Enter: Performs the transfer selected by the selection or the jump code.

Field Descriptions

(Jump Code): (Optional)

A 10-position alphabetic or numeric field containing the jump code for this screen. A screen's jump code automatically appears in the Jump Code field for that screen.

To *jump* to another screen, press **Home**, type the jump code of the screen to which you want to jump, then press **Enter**.

See the "Jump Codes" section earlier in this chapter for further information on using jump codes.

(Selection): (Optional)

A 1-character field used to make a menu selection. Type a valid value (1 through 5), and press **Enter** to move to the selected screen.

System Options Maintenance Screen

EDIM301

Purpose

The System Options Maintenance screen enables you to view or update system-level parameters on the Online Control file (EDIOCF).

The Online Control file contains parameter settings that control the operation of the Gentran:Control system, including whether the system is running; the types of messages to be printed on the Online Log file; and the frequency of system scans. The System Options Maintenance screen automatically displays the System Option record from the Online Control file.

How to Access

You can access the System Options Maintenance screen in either of the following ways:

- From the Control Main Menu, type **1** to select System Options Maintenance and press **Enter**.
- Type **7.1** in the Jump Code field of any screen and press **Enter**.

Screen Example

The following example illustrates the System Options Maintenance screen.

```

EDIM301 7.1_____ SYSTEM OPTIONS MAINTENANCE          XXX 12/01/2005
                                                    12:00:00

Description.....: GENTRAN:CONTROL_____
                  SAMPLE_SYSTEM_OPTIONS_____

System Status.....: E      E = Enabled          D = Disabled
System Trace.....: D      E = Enabled          D = Disabled
System Type.....:  C      C = Control           R = Realtime

Scan Interval.....: 0120      Seconds
Error User Exit Program.: _____
Error User Exit Data....: _____

Last Update Date.....: 00/00/00 Time: 00:00:00 User:  SCI

Enter PF1=Help          PF3=Exit          PF5=Queue
                          PF10=Updt         PF13=Start
  
```

Function Key Descriptions

Note: Standard function keys, such as **PF1=Help**, **PF3=Exit**, **PF7=Bwd**, **PF8=Fwd**, **PF12=Cancel**, and **PF15=Logoff**, as well as **Enter**, are defined in the Getting Started chapter of this guide.

- PF5=Queue:** Displays the Queue Directory screen.
- PF10=Updt:** Updates the Online Control file parameters with any changes you have entered on the screen.
- PF13=Start:** Starts the Online Scanner/Initiator (EDIEOSI). Confirmation is required. This action can be used to start Gentran:Control if the system has been disabled or if the initiation feature of CICS (Program Load Table or PLT) has not been used to start the system. Enabling the system alone will *not* start Gentran:Control; you must also press **PF13**.

Field Descriptions

(Jump Code): (Optional)

A 10-position alphabetic or numeric field containing the jump code for this screen. A screen's jump code automatically appears in the Jump Code field for that screen.

To *jump* to another screen, press **Home**, type the jump code of the screen to which you want to jump, then press **Enter**.

See "Jump Codes" earlier in this chapter for further information on using jump codes.

Description: (Required)

Two, 40-position (each line) alphanumeric fields used to describe the Gentran:Control system option. Type a description that satisfies your installation requirements for documenting systems.

System Status: (Required)

A 1-position alphabetic field used to enable or disable the Gentran:Control online system for processing. Valid values are:

E = The system is enabled; it is usable for processing but has not necessarily been started.

D = The system is not available for processing. If the system currently is processing, it will shut down at the next scan interval.

Note: The value in this field is checked by the Online Scanner/Initiator (EDIEOSI) at each scan interval to determine whether or not it should continue scanning or disable itself.

If the online system is disabled by the **D** value in this field, all functions within the system are turned off. No processing is performed, even for other options that are enabled.

Note: Changing the status from Disabled to Enabled does not start the system. You must type the EDII transaction in CICS to start the system.

System Trace: (Required)

A 1-position alphabetic field used to determine whether the Gentran:Control online system will register a trace record of its processing activity in the Online Log file. Valid values are:

- E** = The system trace is enabled. This value overrides all traces set in other areas of the system.
- D** = The system trace is disabled. This value enables traces set in other areas of the system to operate.

System Type: (Protected)

A 1-position alphabetic field used to distinguish between the Gentran:Control and Gentran:Realtime (another Gentran:Basic add-on product) systems. Valid values are:

- C** = Gentran:Control
- R** = Gentran:Realtime

Because Gentran:Realtime incorporates all the functionality of Gentran:Control, along with additional features, if you install Gentran:Realtime in the future, the System Options record is replaced in the Gentran:Realtime installation. As a result, R for Gentran:Realtime is the system type displayed.

Scan Interval: (Required)

A 4-position numeric field used to designate the time interval in seconds between cycles of the Online Scanner/Initiator. You must set this interval so that the system processes Queue file options in a timely manner, based on the following criteria:

- If the value in this field is too small, previously submitted translation may not have time to complete before another scan starts, which can result in stall conditions.
 - Note:** Stalls are not errors; they are warnings that processing may not be completing in a timely manner.
- If the scan interval value is too large, the Queues can become full, resulting in slow processing, and possible Queue File Full error conditions.

Error User Exit Program: (Optional)

An 8-position alphanumeric field used to enter the name of the user-supplied CICS program, if any, to be used to process error messages.

- Note:** If the name of an Error User Exit program has been typed in the Error User Exit pgm field on the Queue Options Maintenance screen, Gentran:Control uses that program instead of the Exit program named in this field.

Error User Exit Data: (Optional)

A 20-position alphanumeric field used to specify the data to be passed to the Error User Exit program in the event an error occurs.

Note: Because the same Exit program can be used for Queue files, this data should be used to identify the specific Error Exit used.

Last Update Date (Protected)

An 8-position field that displays the date on which the information on this screen was created or last changed. The date format is MM/DD/YY.

Last Update Time (Protected)

An 8-position field that displays the time at which the information on this screen was created or last changed. The time format is HH:MM:SS.

Last Update User (Protected)

A 3-position field that displays the initials of the user who created or last changed the information on this screen.

Queue Directory Screen

EDIM302

Purpose

The Queue Directory screen enables you to view a list of all the Queue files in the Online Control file (EDIOCF). The display is in numeric order by Queue file number, with 10 entries per screen as you scroll up or down the list.

How to Access

You can access the Queue Directory screen in either of the following ways:

- From the Control Main Menu, type **2** to select Queue Directory and press **Enter**.
- Type **7.2** in the Jump Code field of any screen and press **Enter**.
- From the Control Systems Options Maintenance screen, press **PF5=Queue**.
- From the Queue Options Maintenance screen, press **PF4=Dir**.
- From the Extended Queue Options Maintenance screen, press **PF4=Dir**.

Screen Example

The following example illustrates the Queue Directory screen.

```

Select
EDIM302 7.2_____  QUEUE DIRECTORY                XXX 12/01/2005
                                                    12:00:00

Starting Queue File Number:  ____

A Queue  Description                                     # of      Init JCL/
- 001    CONTROL INSTALLATION VERIFICATION             0  E  O  B  OBX
- 002    CONTROL INSTALLATION VERIFICATION             0  E  B  O  EDIR
- 003    CONTROL INSTALLATION VERIFICATION             1  E  B  B  IBX
- 004    CONTROL INSTALLATION VERIFICATION             0  E  B  N
- 005    CONTROL INSTALLATION VERIFICATION             0  E  O  N
- 006    CONTROL INSTALLATION VERIFICATION             0  E  B  O  EDIR
-
-
-
-

Enter PF1=Help PF2=Data  PF3=Exit PF4=SysOpts  PF5=Maint  PF6=Ddt1
      PF7=Bwd  PF8=Fwd

```

Screen Actions

The screen action is displayed on the top line of the Queue Directory screen. The following table describes the screen action and gives instructions on performing that action.

To perform this task	Using This Screen Action	Perform These Steps
View the Queue Options Maintenance screen for a Queue file.	Select	Type s in the A (Action Code) field for the directory entry you want to select, then press either PF5 , PF6 , or PF2 .

Function Key Descriptions

Note: Standard function keys, such as **PF1=Help**, **PF3=Exit**, **PF7=Bwd**, **PF8=Fwd**, **PF12=Cancel**, and **PF15=Logoff**, as well as **Enter**, are defined in the Getting Started chapter of this guide.

PF2=Data: Displays the Queue Options Data Display screen for an individual Queue file when you have typed an **s** in the **A** (Action Code) field next to the Queue file that you want to view.

PF4=SysOpts: Displays the System Options Maintenance screen.

PF5=Maint: Displays the Queue Options Maintenance screen for an individual Queue file when you have typed an **s** in the **A** (Action Code) field next to the Queue file for which you want to make changes.

PF6=Ddtl: Displays the Queue Options Debug Detail screen for an individual Queue file when you have typed an **s** in the **A** (Action Code) field next to the Queue file you want to view.

Field Descriptions

(Jump Code): (Optional)

A 10-position alphabetic or numeric field containing the jump code for this screen. A screen's jump code automatically appears in the Jump Code field for that screen.

To *jump* to another screen, press **Home**, type the jump code of the screen to which you want to jump, then press **Enter**.

See “*Jump Codes*” earlier in this chapter for further information on using jump codes.

Starting Queue File Number: (Optional)

A 3-position numeric field used to select the Queue file at which you want to begin the screen display. Type a valid value (**001** through **999**), and press **Enter** to adjust the display.

A (Action Code): (Optional)

A 1-position alphabetic field used to indicate the Queue file you want to select for maintenance. Type the valid value **s** in this field to the left of the Queue file you want to select, and press **PF5=Maint** to display the Queue Options Maintenance screen or **PF2=Data** to display Queue Options Data Display screen, or **PF6=Ddtl** to display Queue Options Debug Detail screen.

Queue: (Protected)

A 3-position numeric field indicating the Queue. Only Queues that are defined on the Online Control file, are defined through the Queue Options Maintenance screen, or are loaded during installation are displayed.

Description: (Protected)

A 34-position alphanumeric field used to describe the Queue (how it is used). This is the description entered on the Queue Options Maintenance screen when the option is defined.

of Docs: (Protected)

A 6-position numeric field indicating the number of unprocessed Document Groups currently on the Queue file. After the documents have been processed, this count returns to zero.

Status: (Protected)

A 1-position alphanumeric field indicating the status of the Queue file. Valid values are:

- E** = Enabled; the Queue file can be processed by the Online Scanner/Initiator program, and data can be read from or written to the Queue file.
- D** = Disabled; the Queue file cannot be processed.

Src: (Protected)

A 1-position alphabetic field indicating the source of input data for the Queue file. The Online Scanner/Initiator program (EDIEOSI) uses the value in this field to determine where to find the status information about the Queue file. Valid values are:

- O** = Online; the Online Output Gateway (EDIEOOG) is the input source of the Queue file. Status information for the Queue file is maintained in memory, therefore the Scanner program does not need to re-read the Queue file.
- B** = Batch; batch write program (EDIRQWR) is the input source for the Queue file. Queue file status information is read from the pointer records on the Queue file with each scan interval.

Init Act: (Protected)

A 1-position alphanumeric field indicating the action to be initiated when trigger levels (as defined on the Queue Options Maintenance screen) are reached. Valid values are:

- B** = Batch job; a batch job will be submitted when the trigger level is reached.
- O** = Online transaction; a CICS transaction will be started when the trigger level is reached.
- N** = None; no action will occur when the trigger level is reached.

JCL/Trans: (Protected)

A 4-position alphanumeric field indicating the name of the process associated with the value in the Init Act field.

Value in Init Act Field	Associated JCL/Trans Value
B	The name of the batch JCL to be submitted
O	The name of the CICS transaction to be started
N	Blank

Queue Options Maintenance Screen

EDIM303

Purpose

As the primary control and configuration point for the Queue files, the Queue Options Maintenance screen enables you to add, update, or delete queue-level parameters in the Online Control file (EDIOCF). Using this screen, you will set the following characteristics for the Queue files:

- How data is placed on the Queue file
- How data is to be processed off the Queue file
- When the data is to be processed
- What facilities are used during processing

How to Access

You can access the Queue Options Maintenance screen in either of the following ways:

- From the Control Main Menu, type **3** to select Queue Options Maintenance and press **Enter**.
- Type **7.3** in the Jump Code field of any screen and press **Enter**.
- From the Control Queue Directory, type **s** in the **A** (Action Code) field and press **PF5=Maint**.
- From the Queue Options Data Display, press **PF4=Options**.
- From the Queue Options Debug Detail screen, press **PF4=Options**.
- From the Extended Queue Options Maintenance screen, press **PF5=Options**.

Screen Example

The following example illustrates the Queue Options maintenance screen.

```

EDIM303 7.3 _____  QUEUE OPTIONS MAINTENANCE  XXX 12/01/2005
                                                    12:00:00

Queue File Number.....: 001      GENTRAN:CONTROL_INSTALLATION_TEST_____
                                QUEUE_FILE_001_____
Status.....: E      E=Enabled D=Disabled
Source.....: O      O=Online write B=Batch write
Trace.....: D      E=Enabled D=Disabled
      Trigger Levels      Queue Priority.....: 1 (Value 1-9)
Range (Low/High).....: 0000 / 0002  Doc Groups per Run...: 0001
Maximum Delay Time....: 0000      Minutes (with Low Range)
Time Based Interval...: 0000      EXT or SCH or Minutes
      Initiation Actions
Action to Initiate....: B      B=Batch Job O=Online Trans N=None
Batch JCL Name.....: OBX      Stall Limit.....: 15
Online TransID.....: _____  Appl.Prog.....: _____
Exception Pgm.....: _____  TSQ Store Sw.....: _ A=Auxiliary M=Main
                                C=TSQ Chaining

Error User Exit Pgm...: _____  Error Exit Data.: _____
                                Last Update Date: 00/00/00 Time: 00:00:00 User: SCI

Enter PF1=Help PF2=Data PF3=Exit PF4=Dir PF5=Ext
      PF7=Prev PF8=Next PF9=Add PF10=Updt PF11=Del PF14=Ddtl

```

Function Key Descriptions

Note: Standard function keys, such as **PF1=Help**, **PF3=Exit**, **PF7=Bwd**, **PF8=Fwd**, **PF12=Cancel**, and **PF15=Logoff**, as well as **Enter**, are defined in the Getting Started chapter of this guide.

- PF2=Data:** Displays the Queue Options Data Display screen, which displays the data currently on the Queue file.
- PF4=Dir:** Displays the Queue Directory screen.
- PF5=Ext:** Displays the Extended Queue Options Maintenance screen (if you have typed EXT or SCH in the Time Based Interval field on this screen).
- PF9=Add:** Adds the Queue Options record displayed to the Online Control file.
- PF10=Updt:** Updates the Queue options record you are displaying, to the Online Control file.
- PF11=Del:** Deletes the Queue file options record you are displaying, in two steps: the first time you press **PF11** the system confirms that the record exists on Online Control file. The second time you press **PF11** the system deletes the record.
- PF14=Ddtl:** Displays the Queue Options Debug Detail screen.

Field Descriptions

(Jump Code): (Optional)

A 10-position alphabetic or numeric field containing the jump code for this screen. A screen's jump code automatically appears in the Jump Code field for that screen.

To *jump* to another screen, press **Home**, type the jump code of the screen to which you want to jump, then press **Enter**.

See "Jump Codes" earlier in this chapter for further information on using jump codes.

Queue File Number: (Required)

A 3-position numeric field used to identify the Queue file being added, updated or deleted. Valid values are **001** to **999**. The Queue file number is used by application programs and communication programs to identify to Gentran:Control where to store the data. The number is used to create the CICS file control table name that identifies the data set on which data is stored.

(Queue File Description) (Optional)

Two, 40-position (each line) alphanumeric fields used to describe the Queue file. The value entered in the first 34 positions of the field displays on the Queue Directory screen.

Status: (Required)

A 1-position alphabetic field indicating the queue file status. Valid values are:

- E** = Enabled; the Queue file can be processed by the Online Scanner/Initiator program and data can be read from or written to the Queue file.
- D** = Disabled; the Queue file cannot be processed.

If the Queue file is disabled and then changed to enabled, the system must be reinitialized (type **EDIII** on CICS). The reinitialization rebuilds all the appropriate control areas for the Queue file.

Note: Gentran:Control changes the value in the status field to Disabled if the stall limit value set on this screen is exceeded in processing. The description in this section for the Stall Limit field has related information.

Source: (Required)

A 1-position alphabetic field indicating the source of input data for the Queue file. The Online Scanner/Initiator program (EDIEOSI) uses the value in this field to determine where to find the status information about the Queue file. Valid values are:

- O** = OnAppl (Online Write); the Online Output Gateway (EDIEOOG) is the input source of the Queue file. Status information for the Queue file is maintained in memory, therefore the Scanner program does not need to re-read the Queue file.
- B** = Batch (Batch Write); the Gentran:Basic batch system is the input source of the Queue file (through utility program EDIRQWR). Status information for the Queue file is refreshed from the Checkpoint file with each scan interval.

Trace: (Required)

A 1-position alphabetic field indicating the Queue trace parameter. Valid values are:

- E** = Enabled; all online access to this Queue file causes informational messages to be written to the Online Log file.
- D** = Disabled; informational messages are not written to the Online Log file.

Queue Priority (Optional)

A 1-position numeric field that indicates the priority in which the queues are processed. Valid values are **1 – 9**. Queues with a priority of 1 are processed first. Queues with a priority of 9 process last. The default value is 5.

Trigger Levels: (Optional)

These four fields instruct the Online Scanner/Initiator (EDIEOSI) when to invoke Queue file processing. Three types of trigger level criteria may be:

- High range
- Low range/Maximum delay time
- Time-based interval

Queue file processing can be initialized in two different modes.

- When "any" of the criteria types have been met. Each criteria type is evaluated separately and queue file processing is initiated whenever any of them are met.
- When "all" of the criteria types have been met. This requires the use of the Extended Queue Options Maintenance screen (EDIM305) to "schedule" when the High Range and Low Range trigger levels are to be evaluated.

Each time the Online Scanner/Initiator runs, it evaluates the trigger level criteria to determine if queue file processing is to be initiated. At least one of the criteria types must be specified in order for queue file processing to be initiated. If none are specified, document groups will accumulate in the queue file.

The trigger level criteria, as well as the scan interval on the System Options Maintenance (EDIM301) screen, should be adjusted and fine-tuned until they provide appropriate system throughput.

The size of the Queue file should also be considered when specifying the trigger level criteria. A queue file must be large enough to accumulate document groups between the times that queue file processing is initiated.

See "File Descriptions" in Chapter 5, "File Descriptions," in this guide for more information about queue file size.

Range (Low/High): (Optional)

Two 4-digit numeric fields that indicate the minimum and maximum number of document groups that are required to initiate processing of the queue file. The range of valid values is **0000** to **9999**. The Range (Low) value cannot exceed the Range (High) value. The Online Scanner/Initiator does not evaluate the Range (Low or High) field if the value is 0000.

The queue file process initiates when either of the following are true:

- The number of document groups on the queue file is equal to or exceeds the Range (Low) value and the number of minutes since the queue file was last processed is equal to or exceeds the Maximum Delay Time value.
- The number of document groups on the queue file is equal to or exceeds Range (High) value.

Doc Groups per Run: (Optional)

A 4-digit numeric field that specifies the number of document groups to include as a logical unit of work during processing. It is only used when the Action to Initiate is set to 'O' (Online Trans).

If Doc Groups per Run Field is...	The documents in queue are processed...
Blank	As one unit of work
0000	As one unit of work
Equal to Range High Value	As one unit of work
Equal to any other value	That number of documents is processed as one unit of work. The system processes all documents in similar size units of work until all documents are processed.

Screen Example

```

EDIM303 7.3 _____ QUEUE OPTIONS MAINTENANCE XXX 12/01/2005
                                                    12:00:00

Queue File Number.....: 007          TEST QUEUE - BATCH TO ONLINE _____

Status.....: E                      E=Enabled D=Disabled
Source.....: O                      O=Online write B=Batch write
Trace.....: D                      E=Enabled D=Disabled
Trigger Levels
Range (Low/High).....: 0002 / 0006   Queue Priority.....: 5 (Value 1-9)
Maximum Delay Time....: 0004         Doc Groups per Run...: 0010
Time Based Interval...: 0000         EXT or SCH or Minutes
Initiation Actions
Action to Initiate...: O              B=Batch Job O=Online Trans N=None
Batch JCL Name.....: _____     Stall Limit.....: 15
Online TransID.....: EDIR            Appl.Prog.....: EDIR103_
Exception Pgm.....: _____      TSQ Store Sw....: C A=Auxiliary M=Main
                                                    C=TSQ Chaining

Error User Exit Pgm...: _____   Error Exit Data.: _____

Last Update Date: 12/01/05 Time: 12:00:00 User: XXX

Enter PF1=Help PF2=Data PF3=Exit PF4=Dir PF5=Ext
      PF7=Prev PF8=Next PF9=Add PF10=Updt PF11=Del PF14=Ddt1

```

The above screen shows that the translation will start after 0006 documents are present on the queue file, but it will process at most 0010 documents in one translation. So, if there are 12 documents on the file, the first 10 will be processed as one unit of work and the last 2 will process as another unit of work.

Maximum Delay Time: (Optional)

A 4-position numeric field that is used in conjunction with the Range (Low) field to define the number of minutes to delay processing after the Range (Low) criteria have been met. The range of valid values is 0000 to 9999. If the Range (Low) value is greater than 000, the Maximum Delay Time value must also be greater than 0000. The Online Scanner/Initiator does not evaluate the Maximum Delay Time if the Range (Low) value is 0000.

Queue file processing is initiated when the number of document groups on the queue file is equal to or exceeds the Range (Low) value and the number of minutes since the queue file was last processed is equal to or exceeds the Maximum Delay Time value.

Time Based Interval: (Optional)

A 4-position alphanumeric field that defines the interval at which queue file processing will be initiated. Valid values are:

XXXX = A number of minutes from 0001 to 9999 that indicates the minimum number of minutes that queue file processing will be delayed. When the number of minutes that have passed since the queue file was last processed is equal to or exceeds XXX, queue file processing is initiated regardless of the other trigger level specifications.

EXT = This indicates that the Extended Queue Options Maintenance screen (EDIM305) will be used to define different Time Based Intervals for each day of the week and for time periods within each day.

SCH = This indicates that the Extended Queue Options Maintenance screen (EDIM305) will be used to define a schedule when the other trigger level criteria will be evaluated. This schedule can specify the days of the week and the time periods within each day.

When either EXT or SCH is specified, you must press **PF5=Ext** to display the Extended Queue Options Maintenance screen (EDIM305) so that the extended time based intervals can be specified.

Typing **0000** in this field causes the Online Scanner/Initiator to not evaluate it.

Initiation Actions: (Optional)

Initiation actions indicate to Gentran:Control what actions to perform once a trigger level is satisfied.

Action to Initiate: (Optional)

A 1-position alphabetic field indicating the action for Gentran:Control to perform when a trigger level is satisfied. Valid values are:

- B** = Batch Job; initiate a batch job. The Batch JCL Name field specifies the JCL to be submitted. This JCL can be a Gentran:Basic job or any JCL that will process the data from the Queue file.
- O** = Online Trans; initiate an online task. The Online TransID and Appl.Prog fields specify the information required to initiate the task.
- N** = None; take no action. When the value in the Stall Limit field is exceeded, this field is set to this value. This value also can be used if your batch JCL is to be submitted on a schedule at predetermined time intervals.

Batch JCL Name: (Optional)

A 3-character alphabetic field used to designate the name of the JCL member to be submitted when the Action to Initiate field is set to B. This JCL can execute either a Gentran application or a user application. The JCL member must be present in the EDIRJCL file. Add JCL members to this file using batch program EDIRJCLX.

Stall Limit: (Optional)

A 2-position numeric field indicating the number of times Gentran:Control will attempt to process the data before it disables the Queue file. Stalls are encountered when processing of the data from the Queue file has taken long enough that another pass of the Online Scanner/Initiator has completed. Valid values are:

- XX** = A number from 01 to 99 (if you want Gentran:Control to allow unlimited stalls, set the value to 99).
- 15** = This is the default value.

Note: This field is used only with document-based processing and batch JCL submissions. Do not use this field with time interval triggers.

Online TransID: (Optional)

A 4-position alphabetic field indicating the CICS TransID to be initiated. Valid values are any CICS TransID.

When you want to read the data off the Queue file and pass it to your application, type the Gentran:Control TransID value **EDIR** in this field.

Appl.Prog: (Optional)

An 8-position alphanumeric field indicating the name of the user-written application program that will receive the data read off the Queue file. The program receives the data only if you have typed **EDIR** in the Online TransID field.

Exception Pgm: (Optional)

An 8-position alphanumeric field used to indicate the name of the Exception Exit program (see sample program EDIEXIT1). This program is executed by the Online Queue Read program (EDIEOQR or EDIROQR) if an error occurs during processing of the data on the Queue file. When errors are encountered in the user application program (as indicated by the value in the Appl.Prog field on this screen), Gentran:Control keeps the data on the Queue file and attempts to reprocess the data. The Exception Exit program enables you to bypass the invalid data and to continue processing with the remaining data.

Note: You must type a value of O in the Action to Initiate field and a value of EDIR in the Online TransID field in order to use the Exception Exit program named in this field.

See the section “Exception Exit Program” in Chapter 4 of this guide for more information about the Exception Exit program.

TSQ Store Sw: (Optional)

A 1-position alphabetic field indicating whether Queue file data will be passed to the user application program by means of auxiliary TSQs or main TSQs. Valid values are:

- A** = Use Auxiliary storage.
- C** = Use Auxiliary storage with chaining of multiple TSQs.
- M** = Use Main storage.
- Blank** = Use Main storage (this is the default value).

Note: Chaining of TSQ refers to the use of multiple TSQs to hold the data with each TSQ containing a record that identifies the TSQ that holds the next group of records. TSQs can hold up to 32,767 records, so if the data has more than that number of records the data will span more than 1 TSQ. When the store switch is set to a value other than C, the Gentran:Control system will pass one TSQ at a time and any user program must be prepared to process data from multiple calls. When chaining is used, the Gentran:Control system will write all the data to multiple TSQs (chained together) and then pass them in one call to the user program. The user program must be able to handle the chaining process.

Error User Exit Pgm: (Optional)

An 8-position alphanumeric field used to enter the name of the user-supplied CICS program (see sample program EDIEXIT2) that will be linked to when any message that has an error level greater than 4 is encountered during Queue file processing.

The user-supplied CICS program is link by the Online Message Handler program (EDIEOMH) when the system encounters a CICS system error or any internal Gentran:Control errors. This field facilitates automated operations by enabling Gentran:Control to alert a user-automation system when an error occurs.

Error Exit Data: (Optional)

A 20-position alphanumeric field used to specify the data to pass to the Online Error User Exit program in the event that an error occurs during processing.

The data is passed to the Online Error User Exit program, along with error information. If the same program is used for all error exits, the data can be used to identify the particular process or individual that needs to be notified about the error (e.g., an E-Mail address or name may be specified in the exit data).

See the section “Online Error User Exit” in Chapter 4 of this guide for more information about the Online Error User Exit program.

Last Update Date (Protected)

An 8-position field that displays the date on which the information on this screen was created or last changed. The date format is MM/DD/YY.

Last Update Time (Protected)

An 8-position field that displays the time at which the information on this screen was created or last changed. The time format is HH:MM:SS.

Last Update User (Protected)

A 3-position field that displays the initials of the user who created or last changed the information on this screen.

Online Log Display Screen

EDIM304

Purpose

The Online Log Display screen enables you to view the status of Gentran:Control system activity in real-time. As the system runs (mainly as background CICS tasks), errors and other critical events are recorded on the Online Log file.

This screen enables you to view the Online Log file in a console-type fashion. The most recent entries are displayed. As new entries are added, the display scrolls upwards, with the most recent entries listed at the bottom of the display.

This screen only displays log messages generated by applications in the Gentran:Control system. To view messages generated by the Gentran:Basic, Gentran:Realtime, or Gentran:Viewpoint systems, use the Online Log Display screen for the corresponding system.

How to Access

You can access the Online Log Display screen in either of the following ways:

- From the Control Main Menu, type **4** to select Online Log Display and press **Enter**.
- Type **7.4** in the Jump Code field of any screen and press **Enter**.

Screen Example

The following example illustrates the Online Log Display screen.

```

Select
EDIM304 7.4 _____ ONLINE LOG DISPLAY          XXX   12/01/2005
                                                12:00:00
Start: 12/01/2005 12:00:00 Stop:                Last: 12:00:00 Scan: 0030
Filters====> Errors Only: _   Program Only: _____
Position      Task #      TranID      Time      Date      Max Count
Criteria====> _____      _____      _____      _____      _____      0450

A   Task   Tran   Time      Date      Term   Program   Error Code
-   03895  EDI1   12:00:00  12/01/2005  EDIR930 EDI-60708-I 00
    REPORT QUEUED, TSQNAME : EDIQA00A
-   04057  EDI1   12:00:00  12/01/2005  EDIR930 EDI-60708-I 00
    REPORT QUEUED, TSQNAME : EDIQA00D
-   04190  EDI1   12:00:00  12/01/2005  EDIR930 EDI-60708-I 00
    REPORT QUEUED, TSQNAME : EDIQA00G
-   04296  EDI1   12:00:00  12/01/2005  EDIR930 EDI-60708-I 00
    REPORT QUEUED, TSQNAME : EDIQA00J
-   04382  EDI1   12:00:00  12/01/2005  EDIR930 EDI-60708-I 00
    REPORT QUEUED, TSQNAME : EDIQA00M
-   00020  EDI1   12:00:00  12/01/2005  EDIEOSI EDI-10308-I 00
    ONLINE SCANNER/INITIATOR INITIALIZED SUCCESSFULLY BY PLT

Enter PF1=Help          PF3=Exit          PF5=Action
      PF7=Bwd   PF8=Fwd
  
```

Screen Actions

The screen action is displayed on the top line of the Online Log Display screen. The following table describes the screen action and gives instructions on performing that action.

To Perform This Task	Using This Screen Action	Perform These Steps
View data for a particular log entry.	Select	Type s in the A (Action Code) field for the log entry you want to select, then press PF5 .

Function Key Descriptions

Note: Standard function keys, such as **PF1=Help**, **PF3=Exit**, **PF7=Bwd**, **PF8=Fwd**, **PF12=Cancel**, and **PF15=Logoff**, as well as **Enter**, are defined in the Getting Started chapter of this guide.

PF5=Action: Displays the Online Log Detailed Display screen for the selected transaction, when you have typed an **s** in the A (Action Code) field next to the log entry for which you want to view data.

Field Descriptions

(Jump Code): (Optional)

A 10-position alphabetic or numeric field containing the jump code for this screen. A screen's jump code automatically appears in the Jump Code field for that screen.

To *jump* to another screen, press **Home**, type the jump code of the screen to which you want to jump, then press **Enter**.

See "Jump Codes" earlier in this chapter for further information on using jump codes.

Start (Date): (Protected)

A 10-position alphanumeric field indicating the starting date for the most recent start of the Online Scanner/Initiator. Valid format is MM/DD/YYYY. If the CICS system has been brought up without starting the Online Scanner/Initiator program, this field is blank.

Start (Time): (Protected)

An 8-position alphanumeric field indicating the starting time for the most recent start of the Online Scanner/Initiator. Valid format is HH:MM:SS. If the CICS system has been brought up without starting the Online Scanner/Initiator program, this field is blank.

Stop (Date): (Protected)

A 10-position alphanumeric field indicating the date when the most recent cycle of the Online Scanner/Initiator stopped. Valid format is MM/DD/YYYY.

This field is blank when the Online Scanner/Initiator is running or when the CICS system has been brought up and the Scanner has not been started. This field contains a value only when the value in the System Status field on the System Options Maintenance screen has been changed to Disabled.

Stop (Time): (Protected)

An 8-position alphanumeric field indicating the time when the most recent cycle of the Online Scanner/Initiator stopped. Valid format is HH:MM:SS.

This field is blank when the Online Scanner/Initiator is running or when the CICS system has been brought up and the Scanner has not been started. This field contains a value only when the value in the System Status field on the System Options Maintenance screen has been changed to Disabled.

Last: (Protected)

An 8-position alphanumeric field indicating the time of the last run of the Online Scanner/Initiator. Valid format is HH:MM:SS. This field is blank if the Scanner is not running.

Scan: (Protected)

A 4-position numeric field indicating the current scan interval as it is entered on the System Options Maintenance screen. The value in this field determines the time (in seconds) between runs of the Online Scanner/Initiator.

Filters: (Optional)

A filter is used to restrict a program's error and message display. Filters are only active after a value is entered. If a value is entered in combination with the position criteria, the Position Criteria is processed first.

Errors Only (filter): (Optional)

A 1-position alphanumeric field. Valid values are **Y**, **N**, and **space**. When the valid value is Y, only errors, severe errors, and fatal errors are displayed (values E, F, and S).

Errors display starting with the last error message on the screen and processing backwards through a file. If no error message is currently on the screen, error messages display as they are found processing backwards through the file. You can use **PF7=Bwd** or **PF8=Fwd** to scroll through error messages. When used in conjunction with the Program Filter, errors display for the specific program entered.

Program (filter): (Optional)

An 8-position alphanumeric field. Valid values are any Gentran:Control program.

After a valid value is entered, only messages for the specified program display. Messages for the specified program display starting with the last message on the screen and processing backwards through the file. If no message is currently displayed, messages display for that program as they are found, processing backwards through the file.

You can use **PF7=Bwd** or **PF8=Fwd** to scroll through the messages for the program. When used in conjunction with the Errors Only Filter, error messages display for the specified program.

Position Criteria: (Optional)

The Position Criteria is used to position display of the Online Log file at a specific point in the file, based on the criteria you enter. You may enter any combination of position criteria. When no position criteria is entered, the last record on the file (e.g., the most current record) is the last entry on the screen.

When you press **Enter**, searching for position criteria begins with the last record on the Online Log file. When you press **PF7=Bwd** or **PF8=Fwd**, searching for position criteria begins with the last record displayed on the screen.

Task #: (Optional)

A 7-position numeric field used to position the display of the Online Log file at the most recent entry of a specific CICS task number. Type the task number of the entry whose data you want to view. Valid values are any valid CICS task number. Gentran:Control searches for an exact match of the task number you enter.

TranID: (Optional)

A 4-position alphanumeric field used to position the display of the Online Log file at the most recent entry of a specific CICS transaction ID. Type the transaction ID of the entry whose data you want to view. Valid values are any valid CICS transaction ID (some of the primary Gentran:Control transaction IDs follow):

EDIA = Asynchronous Gateway

EDIB = Online Batch Initiator

EDII = Online Scanner/Initiator

EDIR = Online Queue Read

EDIX = System Status Toggle

EDI1 = Separator Gateway

Time (for Position Criteria): (Optional)

An 8-position alphanumeric field used to position the display of the Online Log file at the most recent entry whose time is equal to or less than the time value in this field. Type the transaction time at which you want Gentran:Control to start the display. Valid format is HH:MM:SS.

Date (for Position Criteria): (Optional)

A 10-position alphanumeric field used to position the display of the Online Log file at the most recent entry where the date is equal to or less than the value in this field. Type the date on which you want Gentran:Control to start the display. Valid format is MM/DD/YYYY.

Max Count (for Position Criteria): (Required)

A 4-position numeric field used to indicate the maximum number of Online Log file entries to read during a search for position criteria. Type the number of entries you want Gentran:Control to search. The default value is the value entered on the Configuration Maintenance screen.

If no records are found that match the selection criteria you entered, the message EXCEEDED MAX SEARCH COUNT displays. In this case, you can press **PF7** or **PF8** to continue the search, or increase the Max Count field value and search again.

Note: Response time becomes slower as the number value in this field is increased, because more records are searched.

A (Action Code): (Optional)

A 1-position alphabetic field used to indicate the log entry whose data you want to view. Type the valid value **s** in this field to the left of the transaction you want to select, and press **PF5=Action** to display the Online Log Detail Display screen for the selected transaction.

Task: (Protected)

A 7-position alphanumeric field indicating the CICS task number of the task issuing the log entry.

Tran: (Protected)

A 4-position alphanumeric field indicating the CICS transaction ID of the task issuing the log entry.

Time: (Protected)

An 8-position alphanumeric field indicating the current time of the task issuing the log entry. Format is HH:MM:SS.

Date: (Protected)

A 10-position alphanumeric field indicating the current date of the task issuing the log entry. Format is MM/DD/YYYY.

Term: (Protected)

A 4-position alphanumeric field indicating the terminal ID of the task issuing the log entry. If this field is blank, the task was executed in background CICS.

Program: (Protected)

An 8-position alphanumeric field indicating the name of the Gentran:Control program issuing the log entry.

Error Code: (Protected)

A 14-position alphanumeric field that displays the error/informational number, severity indicator, and return code generated by the task issuing the log entry. Valid format is:

EDI-XXXXX-Y-ZZ

Where:

EDI-XXXXX is the message number

Y is the severity indicator

ZZ is the return code value

See “Processing Messages” in Chapter 2 of the *Gentran:Basic System Message Guide* for information about the indicated message.

Severity indicator values are:

- I = Informational; this value usually indicates trace messages.
- T = Trace; the error was produced by the Trace facility.
- W = Warning; some action may be required.
- E = Severe error; controlled termination of processing.
- F = Fatal error; immediate termination of processing.

Return code values are:

- 00 = Normal; no warnings or errors occurred.
- 04 = Warning; at least one warning level occurred.
- 08 = Error; invalid data has been encountered. Some action may be required.
- 12 = Severe error; processing was terminated.
- 16 = Fatal error; processing was terminated.

(Error Message): (Protected)

A 73-position alphanumeric field which is the second line of a log entry on this screen. This field corresponds to the message number portion of the value entered in the Error Code field; it contains the error/informational message generated by the task issuing the log entry.

Extended Queue Options Maintenance Screen

EDIM305

Purpose

The Extended Queue Options Maintenance screen enables you to view or update queue-level time interval parameters in the Online Control file using more specific criteria than the Queue Options Maintenance screen offers.

Using the Extended Queue Options Maintenance screen, you can control processing precisely by setting different processing time limits for each day of the week and for time periods within each day. You can enter multiple start and stop periods for each day, or make no entry. If you set up time intervals with overlapping start and stop time ranges, the smallest interval is used.

How to Access

You can access the Extended Queue Options Maintenance screen in the following way:

- From the Queue Options Maintenance screen, press **PF5=Ext**.

Note: You must type the value **EXT** or **SCH** in the Time Based Interval field on the Queue Options Maintenance screen and press **PF10=Updt** before you press **PF5=Ext**.

Screen Example

The following example illustrates the Extended Queue Options Maintenance screen.

Day of Week (S M T W T F S)	Start (HHMM)	Stop (HHMM)	Interval (Minutes)
_ X _ X _ X _	0800	1200	0020
_ _ X X X _ _	0100	1700	0030
_____	_____	_____	_____
_____	_____	_____	_____
_____	_____	_____	_____
_____	_____	_____	_____
_____	_____	_____	_____
_____	_____	_____	_____
_____	_____	_____	_____
_____	_____	_____	_____
_____	_____	_____	_____

EDIM305 _____ EXTENDED QUEUE OPTIONS MAINTENANCE XXX 12/01/2005
12:00:00

Queue File Number: 004 GENTRAN:CONTROL INSTALLATION TEST
QUEUE FILE 004

Last Update Date: 12/01/05 Time: 12:00:00 User: XXX

Enter PF1=Help PF2=Data PF3=Exit PF4=Dir PF5=Options PF6=Ddtl
PF10=Updt

Function Key Descriptions

Note: Standard function keys, such as **PF1=Help**, **PF3=Exit**, **PF7=Bwd**, **PF8=Fwd**, **PF12=Cancel**, and **PF15=Logoff**, as well as **Enter**, are defined in the Getting Started chapter of this guide.

- PF2=Data:** Displays the Queue Option Data.
- PF4=Dir:** Displays the Queue Directory screen.
- PF5=Options:** Displays the Queue Options Maintenance screen.
- PF6=Ddtl:** Displays the Queue Options Debug Detail screen.
- PF10=Updt:** Updates Queue file information, for the Queue file number entered, to the Online Control file.

Field Descriptions

(Jump Code): (Optional)

A 10-position alphabetic or numeric field containing the jump code for this screen. A screen's jump code automatically appears in the Jump Code field for that screen.

To *jump* to another screen, press **Home**, type the jump code of the screen to which you want to jump, then press **Enter**.

See “Jump Codes” earlier in this chapter for further information on using jump codes.

Queue File Number: (Protected)

A 3-position numeric field used to identify the Queue file being viewed or updated. Valid values are **001** to **999**. The Queue file number is used to construct the CICS filenames and to validate the Queue file data set.

(Description): (Protected)

A two-line, 40-position (each line) alphanumeric field containing the description of the Queue file.

The following fields occur 10 times on the screen.

Day of Week: (Optional)

Seven 1-position alphanumeric fields (one for each day of the week) used to designate the day(s) of the week on which you want Gentran:Control to perform the directions designated by the values in the Start, Stop, and Interval fields. Type any non-blank character to designate a day.

Start: (Optional)

A 4-position numeric field designating the time when you want to start processing. The valid format is HH:MM, where HH is hours and MM is minutes.

Stop: (Optional)

A 4-position numeric field designating the time when you want to stop processing. The valid format is HH:MM.

Note: If the values in the Start and Stop fields indicate overlapping time ranges, Gentran:Control uses the smallest designated interval.

Interval: (Optional)

A 4-position numeric field indicating the interval time (in minutes) between the last time when processing was initiated for the indicated Queue file (either as the result of this parameter or the document trigger levels) and the next time when processing should be initiated for this Queue file.

When the Time Based Interval field on the Queue Options screen (EDIM303) contains the value SCH, any Interval values specified here will be ignored.

Note: To request processing at a specific time, set the values in the Start and Stop fields to the same time, and specify an Interval field value of 0000. The requested processing will initiate on the first cycle of the Online Scanner/ Initiator following the specified start time.

Last Update Date (Protected)

An 8-position field that displays the date on which the information on this screen was created or last changed. The date format is MM/DD/YY.

Last Update Time (Protected)

An 8-position field that displays the time at which the information on this screen was created or last changed. The time format is HH:MM:SS.

Last Update User (Protected)

A 3-position field that displays the initials of the user who created or last changed the information on this screen.

Queue Options Debug Detail Screen

EDIM306

The Queue Options Debug Detail screen enables you to review internal information about the Queue file in order to locate Queue file problems. You also can use the screen to evaluate the most recent processing characteristics of the Queue file.

Note: This screen is primarily used when contacting Gentran Support for help in determining Queue file problems.

Many of the fields on the screen display identical information (the first two columns of the display contain related fields, as do the last two columns). These multiple fields enable you to view discrepancies; when fields that should be identical are different, Queue file errors occur. Using this screen to view these discrepancies enables you to identify errors more easily.

The Queue Options Debug Detail screen displays in two variations, based on the characteristics defined for the Queue file you are investigating: even-numbered Gentran:Control Queue files and odd-numbered Gentran:Control Queue files.

EDIM306 for Even-Numbered Queue Files

Purpose

The Queue Options Debug Detail screen for even-numbered Gentran:Control Queue files enables you to view internal information about the Queue file. This screen enables you to locate Queue file problems, and to evaluate the most recent processing characteristics of the Queue file.

How to Access

You can access the Queue Options Debug Detail screen for even-numbered Gentran:Control Queue files in the following way:

- From the Queue Options Maintenance screen, press **PF14=Ddtl**.
- From the Queue Directory screen, type **s** in the **A** (Action Code) field and press **PF6=Ddtl**.
- From the Queue Options Data Display screen, press **PF6=Ddtl**.
- From the Extended Queue Options Maintenance screen, press **PF6=Ddtl**.

Screen Example

The following example illustrates the Queue Options Debug Detail screen for even-numbered Gentran:Control Queue files.

```

EDIM306 _____  QUEUE OPTIONS DEBUG DETAIL          XXX    12/01/2005
                                                12:00:00

Queue File Number...: 002  CONTROL INSTALLATION VERIFICATION
                        SAMPLE QUEUE FILE 002
                        Internal      Last      Last      Queue
                        TS Queue     Processed  Written   Created
Max Nbr Recs.....:    501          501
Pointer.....:         33           33           33      4
Date.....: 12/01/2005 12/01/2005 12/01/2005 12/01/2005
Time.....: 12:00:00 12:00:00 12:00:00 12:00:00
Acc Doc Counter...:    31           31           31      2
Action Counter....:     0
Action to Initiate Pointers
Save Ptr.....:
Save Doc Counter...:
Task Scan Ptr.....:
CKP Ptr.....:
CKP Doc Counter...:
Task Post Ind.....:

Enter PF1=Help PF2=Data  PF3=Exit PF4=Options

```

Function Key Descriptions

Note: Standard function keys, such as **PF1=Help**, **PF3=Exit**, **PF7=Bwd**, **PF8=Fwd**, **PF12=Cancel**, and **PF15=Logoff**, as well as **Enter**, are defined in the Getting Started chapter of this guide.

PF2=Data: Displays the Queue Options Data Display screen.

PF4=Options: Displays to the Queue Options Maintenance screen.

*Field Descriptions***(Jump Code):** (Optional)

A 10-position alphabetic or numeric field containing the jump code for this screen. A screen's jump code automatically appears in the Jump Code field for that screen.

To *jump* to another screen, press **Home**, type the jump code of the screen to which you want to jump, then press **Enter**.

See "Jump Codes" earlier in this chapter for further information on using jump codes.

Queue File Number: (Required)

A 3-position numeric field indicating the Queue file number. Valid values are even numbers from **002** through **998**.

(Description): (Protected)

A two-line, 40-position (each line) alphanumeric field containing the Queue File Description as it has been entered on the Queue Options Maintenance screen.

Max Nbr Recs for Internal TS Queue: (Protected)

An 11-position alphanumeric field indicating the number of records specified when the Queue file was defined. This information is the number of 4088-byte blocks that can be used to hold application or EDI data on the Queue file.

Max Nbr Recs for Last Processed: (Protected)

An 11-position alphanumeric field indicating the number of records specified when the Queue file was defined. The value in this field should match the value in the Max Nbr Recs for Internal TS Queue field.

Max Nbr Recs for Last Written: (Protected)

Not applicable.

Max Nbr Recs for Queue Created: (Protected)

Not applicable.

Pointer for Internal TS Queue: (Protected)

An 11-position alphanumeric field containing the relative record number of the last processed set of data.

Pointer for Last Processed: (Protected)

An 11-position alphanumeric field containing the relative record number of the last processed set of data.

Pointer for Last Written: (Protected)

An 11-position alphanumeric field containing the relative record number of the last set of data written to the Queue file. Current data waiting to be processed is located in the records between the Last Processed and the Last Written.

The data is placed on each relative record on the Queue file by squeezing as many characters as possible into each 4088-byte relative record. The Last Processed Pointer points to the last block of data that was read. The Last Written Pointer points to the last block of data that was written.

When the values in the Pointer fields match, the Queue file is empty. When the values in the Pointer fields are not equal, the Queue file contains data and is located in the blocks that are between the Last Processed Pointer and the Last Written Pointer (including the last block). For example, if the Last Processed Pointer value is 5 and the Last Written Pointer value is 8, then the data waiting to be read is in relative records 6, 7 and 8.

Pointer for Queue Created: (Protected)

An 11-position alphanumeric field containing the relative record number of the last set of data written to the Queue file.

Date for Internal TS Queue: (Protected)

A 10-position alphanumeric field indicating the last update date of the internal table with the date the data was last processed off the Queue file.

Date for Last Processed: (Protected)

A 10-position alphanumeric field indicating the date the data was last processed off the Queue file.

Date for Last Written: (Protected)

A 10-position alphanumeric field indicating the date the data was last written to the Queue file.

Date for Queue Created: (Protected)

A 10-position alphanumeric field indicating the date the data was last written to the Queue file.

Time for Internal TS Queue: (Protected)

An 8-position alphanumeric field indicating the last update time of the internal table with the time the data was last processed off the Queue file.

Time for Last Processed: (Protected)

An 8-position alphanumeric field indicating the time the data was last processed off the Queue file.

Time for Last Written: (Protected)

An 8-position alphanumeric field indicating the time the data was last written to the Queue file.

Time for Queue Created: (Protected)

An 8-position alphanumeric field indicating the time the data was last written to the Queue file.

Acc Doc Counter for Internal TS Queue: (Protected)

A 5-position alphanumeric field indicating the current accumulated Document Group count in the internal table. This field represents the accumulated number of Document Groups that have been processed off the Queue file since the Queue file was created.

Acc Doc Counter for Last Processed: (Protected)

A 5-position alphanumeric field indicating the current accumulated Document Group count from the last time the Queue file was processed.

Acc Doc Counter for Last Written: (Protected)

A 5-position alphanumeric field indicating the current accumulated Document Group count from the last time the data was written to the Queue file. The difference between the value in this field and the value in the Acc Doc Counter for Last Processed field is the number of Document Groups waiting to be processed off the Queue file.

Acc Doc Counter for Queue Created: (Protected)

A 5-position alphanumeric field indicating the current accumulated Document Group count from the last time the data was written to the Queue file.

Action Counter: (Protected)

A 5-position numeric field indicating the number of times the Action to Initiate function has been performed for this Queue file.

Action to Initiate Pointers: (Protected)

The values in these fields track Queue file processing that occurs when trigger levels entered on the Queue Options Maintenance screen are satisfied.

The pointers are blank if the Queue file is disabled, if the Gentran:Control system has not been started, or if trigger levels have not been satisfied since the Gentran:Control system was started.

Save Ptr: (Protected)

An 11-position alphanumeric field indicating the relative record number of the most recently initiated activity. This field is usually blank.

Save Doc Counter: (Protected)

A 5-position alphanumeric field indicating the accumulated document group count of the most recently initiated activity. This field usually is blank.

Task Scan Ptr: (Protected)

An 11-position alphanumeric field containing the relative record number of the last processed block of data at the time of the most recently initiated activity.

CKP Ptr: (Protected)

An 11-position alphanumeric field containing the relative record number of the last processed block of data at the time of the most recently initiated activity.

Note: The values in the Task Scan Ptr and the CKP Ptr fields identify the relative records that were processed at the last initiated action.

CKP Doc Counter: (Protected)

A 5-position alphanumeric field indicating the last processed accumulated document count at the time of the most recently initiated activity.

Task Post Ind: (Protected)

A 1-position alphanumeric field indicating whether or not a batch job was submitted at the most recently initiated activity. Valid values are:

Y = Yes; a batch job was submitted.

N = No; a batch job was not submitted.

EDIM306 for Odd-Numbered Queue Files

Purpose

The Queue Options Debug Detail screen for odd-numbered Gentran:Control Queue files enables you to view internal information about the Queue file. This screen enables you to locate Queue file problems and to evaluate the most recent processing characteristics of the Queue file.

Note: This screen is primarily used when contacting Gentran Support for help in determining Queue file problems.

How to Access

You can access the Queue Options Debug Detail screen for odd-numbered Gentran:Control Queue files in the following way:

- From the Queue Options Maintenance screen, press **PF14=Ddtl**.
- From the Queue Directory screen, type **s** in the A (Action Code) field and press **PF6=Ddtl**.
- From the Queue Options Data Display screen, press **PF6=Ddtl**.
- From the Extended Queue Options Maintenance screen, press **PF6=Ddtl**.

Screen Example

The following example illustrates the Queue Options Debug Detail screen for odd-numbered Gentran:Control Queue files.

```

EDIM306 _____ QUEUE OPTIONS DEBUG DETAIL          XXX  12/01/2005
                                                    12:00:00

Queue File Number...: 001  CONTROL INSTALLATION VERIFICATION
                        TEST QUEUE FILE 001
                        Internal      Last      Last      Queue
                        TS Queue      Written   Processed  Created
Max Nbr Recs.....:      501          501          136          136
Pointer.....:          138          136          136          136
Date.....: 12/01/2005  12/01/2005  12/01/2005  12/01/2005
Time.....: 12:00:00    12:00:00    12:00:00    12:00:00
Acc Doc Counter...:          51          50          50          50
Action Counter....:          0
Action to Initiate Pointers
Save Ptr.....:
Save Doc Counter..:
Task Scan Ptr.....:
CKP Ptr.....:
CKP Doc Counter...:
Task Post Ind.....:

Enter PF1=Help PF2=Data  PF3=Exit PF4=Options

```

Function Key Descriptions

Note: Standard function keys, such as **PF1=Help**, **PF3=Exit**, **PF7=Bwd**, **PF8=Fwd**, **PF12=Cancel**, and **PF15=Logoff**, as well as **Enter**, are defined in the Getting Started chapter of this guide.

PF2=Data: Displays the Queue Options Data Display Screen.

PF4=Options: Displays the Queue Options Maintenance screen.

Field Descriptions

(Jump Code): (Optional)

A 10-position alphabetic or numeric field containing the jump code for this screen. A screen's jump code automatically appears in the Jump Code field for that screen.

To *jump* to another screen, press **Home**, type the jump code of the screen to which you want to jump, then press **Enter**.

See "Jump Codes" earlier in this chapter for further information on using jump codes.

Queue File Number: (Required)

A 3-position numeric field indicating the Queue file number. Valid values are odd numbers **001** through **999**.

(Description) (Protected)

A two-line, 40-position (each line) alphanumeric field containing the Queue File Description as it was entered on the Queue Options Maintenance screen.

Max Nbr Recs for Internal TS Queue: (Protected)

An 11-position alphanumeric field indicating the number of records specified when the Queue file was defined. This information is the number of 4088-byte blocks that can be used to hold application or EDI data on the Queue file.

Max Nbr Recs for Last Written: (Protected)

An 11-position alphanumeric field indicating the number of records specified when the Queue file was defined. The value for this field should match the value in the Max Nbr Recs for Internal TS Queue field.

Max Nbr Recs for Last Processed: (Protected)

Not applicable.

Max Nbr Recs for Queue Created: (Protected)

Not applicable.

Pointer for Internal TS Queue: (Protected)

An 11-position alphanumeric field containing the relative record number of the last processed set of data.

Pointer for Last Written: (Protected)

An 11-position alphanumeric field containing the relative record number of the last set of data written to the Queue file. Current data waiting to be processed is located in the records between the Last Processed and the Last Written.

The data is placed on each relative record on the Queue file by squeezing as many characters as possible into each 4088-byte relative record. The Last Processed Pointer points to the last block of data that was read. The Last Written Pointer points to the last block of data that was written.

When the values in the Pointer fields match, the Queue file is empty. When the values in the Pointer fields are not equal, the Queue file contains data and is located in the blocks that are between the Last Processed Pointer and the Last Written Pointer (including the last block). For example, if the Last Processed Pointer value is 5 and the Last Written Pointer value is 8, then the data waiting to be read is in relative records 6, 7 and 8.

Pointer for Last Processed: (Protected)

An 11-position alphanumeric field containing the relative record number of the last processed set of data.

Pointer for Queue Created: (Protected)

An 11-position alphanumeric field indicating the relative record number of the last set of data read from the Queue file.

Date for Internal TS Queue: (Protected)

A 10-position alphanumeric field indicating the last update date of the internal table with the date the data last was written to the Queue file.

Date for Last Written: (Protected)

A 10-position alphanumeric field indicating the date the data last was written to the Queue file.

Date for Last Processed: (Protected)

A 10-position alphanumeric field indicating the date the data last was processed off the Queue file.

Date for Queue Created: (Protected)

A 10-position alphanumeric field indicating the date the data last was read off the Queue file.

Time for Internal TS Queue: (Protected)

An 8-position alphanumeric field indicating the last update time of the internal table with the time the data was last written to the Queue file.

Time for Last Written: (Protected)

An 8-position alphanumeric field indicating the time the data was last written to the Queue file.

Time for Last Processed: (Protected)

An 8-position alphanumeric field indicating the time the data was last processed off the Queue file.

Time for Queue Created: (Protected)

An 8-position alphanumeric field indicating the time the data was last Read off the Queue file.

Acc Doc Counter for Internal TS Queue: (Protected)

A 5-position alphanumeric field indicating the current accumulated Document Group count in the internal table. This field represents the accumulated number of Document Groups that have been processed off the Queue file since the Queue file was created.

Acc Doc Counter for Last Written: (Protected)

A 5-position alphanumeric field indicating the current accumulated Document Group count from the last time the data was written to the Queue file. The difference between the value in this field and the value in the Acc Doc Counter for Last Processed field is the number of Document Groups waiting to be processed off the Queue file.

Acc Doc Counter for Last Processed: (Protected)

A 5-position alphanumeric field indicating the current accumulated Document Group count from the last time the Queue file was processed.

Acc Doc Counter for Queue Created: (Protected)

A 5-position alphanumeric field indicating the current accumulated Document Group count from the last time the data was read off the Queue file.

Action Counter: (Protected)

A 5-position numeric field indicating the number of times the Action to Initiate function has been performed for this Queue file.

Action to Initiate Pointers: (Protected)

The values in these fields track Queue file processing that occurs when trigger levels entered on the Queue Options Maintenance screen are satisfied.

The pointers are blank if the Queue file is disabled, if the Gentran:Control system has not been started, or if trigger levels have not been satisfied since the Gentran:Control system was started.

Save Ptr: (Protected)

An 11-position alphanumeric field containing the relative record number of the most recently initiated activity. This field usually is blank.

Save Doc Counter: (Protected)

A 5-position alphanumeric field indicating the accumulated document group count of the most recently initiated activity. This field usually is blank.

Task Scan Ptr: (Protected)

An 11-position alphanumeric field containing the relative record number of the last processed block of data at the time of the most recently initiated activity.

CKP Ptr: (Protected)

An 11-position alphanumeric field containing the relative record number of the last processed block of data at the time of the most recently initiated activity.

Note: The values in the Task Scan Ptr and CKP Ptr fields identify the relative records that were processed at the most recently initiated activity.

CKP Doc Counter: (Protected)

A 5-position alphanumeric field indicating the last processed accumulated document count at the time of the most recently initiated activity.

Task Post Ind: (Protected)

A 1-position alphanumeric field indicating whether a batch job was submitted at the most recently initiated activity. Valid values are:

Y = Yes; a batch job was submitted.

N = No; a batch job was not submitted.

Queue Options Data Display Screen

EDIM307

Purpose

The Queue Options Data Display screen enables you to view the data written to a Queue file before it has been processed.

How to Access

You can access the Queue Options Data Display screen in the following way:

- From the Queue Options Maintenance screen, press **PF2=Data**.
- From the Queue Directory screen, type **s** in the A (Action Code) field and press **PF2=Data**.
- From the Queue Options Debug Detail screen, press **PF2=Data**.
- From the Extended Queue Options Maintenance screen, press **PF2=Data**.

Screen Example

The following example illustrates the Queue Options Data Display screen.

```

EDIM307 _____ QUEUE OPTIONS DATA DISPLAY          XXX   12/01/2005
                               Unprocessed Records          12:00:00

Queue File Number:  009          TEST QUEUE - ONLINE TO ONLINE ODD # Q
Starting Segment :  000001
Screen Increment :  _____ Relative Screen Number:  00001

*  VENDOR-1PONUMBER-001001010201STERLING_COMMERCE_INC.  4600_LAKEHURST_COURT
   _____COLUMBUS_____OH43017XYZ_COMPUTER_COMPANY_____1212_E_MAIN_ST.
   _____CINCINATTI_____OH43015614-793-7000513-666-666601059507609
   876_____00000100-end
*  VENDOR-1PONUMBER-001002#####
   #####
   _____
   _____00000101-end
*  VENDOR-1PONUMBER-001002####_PURCHASE_ORDER_INSTRUCTIONS_
   #####
   _____
   _____00000110-end
*  VENDOR-1PONUMBER-001002####
LAST RECORD IS CONTINUED ON NEXT PANEL
Enter PF1=Help          PF3=Exit PF4=Options          PF6=Ddt1
      PF7=Bwd  PF8=Fwd

```

Function Key Descriptions

Note: Standard function keys, such as **PF1=Help**, **PF3=Exit**, **PF7=Bwd**, **PF8=Fwd**, **PF12=Cancel**, and **PF15=Logoff**, as well as **Enter**, are defined in the Getting Started chapter of this guide.

PF4=Options: Displays the Queue Options Maintenance screen.

PF6=Ddtl: Displays the Queue Options Debug Detail screen for the Queue file.

Field Descriptions

(Jump Code): (Optional)

A 10-position alphabetic or numeric field containing the jump code for this screen. A screen's jump code automatically appears in the Jump Code field for that screen.

To *jump* to another screen, press **Home**, type the jump code of the screen to which you want to jump, then press **Enter**.

See "Jump Codes" earlier in this chapter for further information on using jump codes.

Queue File Number: (Required)

A 3-position numeric field indicating the Queue file number. Valid values are **001** through **999**.

(Description) (Protected)

A two-line, 40-position (each line) alphanumeric field containing the Queue file description as it was entered on the Queue Options Maintenance screen.

Starting Segment: (Protected)

A 6-position numeric field containing the relative number of the first segment displayed on the screen.

Segment length is variable. The beginning of each segment displayed on the data portion of the screen is denoted by a leading asterisk (*).

Screen Increment: (Optional)

A 4-position alphanumeric field used to designate the increment by which you want to view screens. Valid values are **-999** through **9999**.

You can jump forward within the Queue file by typing a positive number in this field and pressing **Enter**. You can jump backward within the Queue file by typing a negative number in this field (use the minus sign [-]) and pressing **Enter**.

Relative Screen Number: (Protected)

A 5-position numeric field indicating the relative number of the screen currently displayed.

(Data): (Protected)

The body of the screen displays the data contained on the Queue file. Each segment (logical record) of the Queue file is suffixed with the characters **-end**. This designation identifies the end of a segment.

Note: Blanks and unprintable characters are replaced by underscores in the data.

Online Log Detailed Display Screen

EDIM308

Purpose

The Online Log Detailed Display screen enables you to view the status of Gentran:Control system activity in greater detail by viewing messages for an individual task listed on the Online Log Display screen. The Online Log Detailed Display screen filters out the additional messages that make tracking individual tasks difficult in systems with a high volume of simultaneously processing transactions.

How to Access

You can access the Online Log Detailed Display screen in the following way:

- From the Online Log Display screen, type an **s** in the A (Action Code) field to the left of the entry you want to select and press **PF5=Action**.

Screen Example

The following example illustrates the Online Log Detailed Display screen.

```

EDIM308 _____ ONLINE LOG DETAILED DISPLAY XXX 12/01/2005
12:00:00
Start: 12/01/2005 12:00:00 Stop: Last: 12:00:00 Scan: 0030
Filters====> Errors Only: _
Max Count...: 0450

Task #...: 0004190 TranID...: EDI1 Date...: 12/01/2005 Term...:
Error Message Time Program Error Code
REPORT QUEUED, TSQNAME : EDIQA00G
12:00:00 EDIR930 EDI-60708-I 00

EXCEEDED MAX SEARCH COUNT - PRESS PF7 OR PF8 TO CONTINUE SEARCH
Enter PF1=Help PF3=Exit PF4=Log
PF7=Bwd PF8=Fwd

```

Function Key Descriptions

Note: Standard function keys, such as **PF1=Help**, **PF3=Exit**, **PF7=Bwd**, **PF8=Fwd**, **PF12=Cancel**, and **PF15=Logoff**, as well as **Enter**, are defined in the Getting Started chapter of this guide.

PF4=Log: Displays the Online Log Display screen.

Field Descriptions

(Jump Code): (Optional)

A 10-position alphabetic or numeric field containing the jump code for this screen. A screen's jump code automatically appears in the Jump Code field for that screen.

To *jump* to another screen, press **Home**, type the jump code of the screen to which you want to jump, then press **Enter**.

See "Jump Codes" earlier in this chapter for further information on using jump codes.

Start (Date): (Protected)

A 10-position alphanumeric field indicating the starting date for the most recent start of the Online Scanner/Initiator. Valid format is MM/DD/YYYY. If the CICS system has been brought up without starting the Scanner, this field is blank.

Start (Time): (Protected)

An 8-position alphanumeric field indicating the starting time for the most recent start of the Online Scanner/Initiator. Valid format is HH:MM:SS. If the CICS system has been brought up without starting the Scanner, this field is blank.

Stop (Date): (Protected)

A 10-position alphanumeric field indicating the date when the most recent cycle of the Online Scanner/Initiator stopped. Valid format is MM/DD/YYYY.

This field is blank when the Scanner is running or when the CICS system has been brought up and the Scanner has not been started. This field contains a value only when the value in the System Status field on the System Options Maintenance screen has been changed to Disabled.

Stop (Time): (Protected)

An 8-position alphanumeric field indicating the time when the most recent cycle of the Online Scanner/Initiator stopped. Valid format is HH:MM:SS.

This field is blank when the Scanner is running or when the CICS system has been brought up and the Scanner has not been started. This field contains a value only when the value in the System Status field on the System Options Maintenance screen has been changed to Disabled.

Last: (Protected)

An 8-position alphanumeric field indicating the time of the last Scanner run. Valid format is HH:MM:SS. This field is blank if the Scanner is not running.

Scan: (Protected)

A 4-position numeric field indicating the current scan interval as it is set on the System Options Maintenance screen. The value in this field determines the time (in seconds) between runs of the Online Scanner/Initiator.

Filters: (Optional)

A filter is used to restrict a program's error and message display. Filters are only active after a value is entered.

Errors Only (filter): (Optional)

A 1-position alphanumeric field. Valid values are **Y**, **N**, and **space**. When the valid value is Y, only errors, severe errors, and fatal errors display (values E, F, and S).

Errors are displayed starting with the last error message on the screen and processing backwards through a file. If no error message is currently on the screen, error messages are displayed as they are found processing backwards through the file.

PF7=Bwd or **PF8=Fwd** may be used to scroll through error messages.

Max Count: (Required)

A 4-position numeric field used to indicate the maximum number of Online Log file entries to read during a search for position criteria. Type the number of entries you want Gentran:Control to search. The default value derives from the value entered on the Configuration Maintenance screen.

If no records, or less than a full screen of records, are found that match the selection criteria you entered, the message EXCEEDED MAX SEARCH COUNT displays. In this case, you can press **PF7=Bwd** to continue the search, or increase the Max Count field value and search again.

Note: Response time becomes slower as the number value in this field is increased, because more records are searched.

Task #: (Protected)

A 7-position numeric field indicating the CICS task number for the selected task.

TranID: (Protected)

A 4-position alphanumeric field indicating the CICS transaction ID for the selected task.

Date: (Protected)

A 10-position alphanumeric field indicating the date when the selected task processed. Valid format is MM/DD/YYYY.

Term: (Protected)

A 4-position alphanumeric field indicating the terminal ID of the selected task. If this field is blank, the task was executed in background CICS.

Error Message: (Protected)

Two fields (the first, 76-position; the second, 36-position) containing the error/informational message generated by the task issuing the log entry.

Time: (Protected)

An 8-position alphanumeric field indicating the current time of the task issuing the log entry. Format is HH:MM:SS.

Program: (Protected)

An 8-position alphanumeric field indicating the name of the Gentran:Realtime, Gentran:Control, Gentran:Viewpoint, or Gentran:Basic program issuing the log entry.

Error Code: (Protected)

A 14-position alphanumeric field that displays the error/informational number, severity indicator, and return code generated by the task issuing the log entry.

Valid format is:

EDI-XXXXX-Y-ZZ

Where:

EDI-XXXXX is the message number

See the section “Processing Messages” in Chapter 2 of the Gentran:Basic *System Message Guide* for information about the indicated message.

Y is the severity indicator

ZZ is the return code value

Severity indicator values are:

- I = Informational; this value usually indicates trace messages.
- T = Trace; the error was produced by the Trace facility.
- W = Warning; some action may be required.
- E = Severe error; controlled termination of processing.
- F = Fatal error; immediate termination of processing.

Return code values are:

- 00 = Normal; no warnings or errors occurred.
- 04 = Warning; at least one warning level occurred.
- 08 = Error; invalid data has been encountered. Some user action to correct data may be required.
- 12 = Severe error; processing was terminated.
- 16 = Severe error. Processing was terminated.

Separator Main Menu

EDIM934

Purpose

The Separator Main Menu contains four menu options that you can use to set up and review separator processing options.

How to Access

You can access the Separator Main Menu in either of the following ways:

- From the Control Main Menu, type **5** to select Separator Main Menu and press **Enter**.
- Type **7.5** in the Jump Code field of any screen and press **Enter**.

Screen Example

The following example illustrates the Separator Main Menu.

```
EDIM934 7.5_____ SEPARATOR MAIN MENU          XXX   12/01/2005
                                                    12:00:00

Type the number of your selection below and press ENTER, or
press the PF3 key to Exit.

      _  1.  Separator Systems Options Maintenance
          2.  Priority Options Directory
          3.  Priority Options Maintenance
          4.  Separator Monitor

Enter PF1=Help          PF3=Exit
                                                    PF15=Logoff
```

The Separator Main Menu contains four menu options, which enable you to perform the main tasks of the Separator subsystem. The list of menu options, as well as a brief description of each option, follows:

Menu Option		Description
1.	Separator Systems Options Maintenance	Enables you to perform maintenance functions for separator systems options, using the Separator Systems Options Maintenance screen.
2.	Priority Options Directory	Enables you to select a priority option from the Priority Options Directory screen. To perform maintenance on that priority option, you must use the Priority Options Maintenance screen.
3.	Priority Options Maintenance	Enables you to perform maintenance on a selected priority option, using the Priority Options Maintenance screen.
4.	Separator Monitor	Enables you to view the entries in the Monitor Header file (EDIRMNH), using the Separator Monitor screen.

Function Key Descriptions

Note: Standard function keys, such as **PF1=Help**, **PF3=Exit**, **PF7=Bwd**, **PF8=Fwd**, **PF12=Cancel**, and **PF15=Logoff**, as well as **Enter**, are defined in the Getting Started chapter of this guide.

Field Descriptions

(Jump Code): (Optional)

A 10-position alphabetic or numeric field containing the jump code for this screen. A screen's jump code is displayed automatically in the Jump Code field for that screen.

To *jump* to another screen, press **Home**, type the jump code of the screen to which you want to jump, then press **Enter**.

See "Jump Codes" earlier in this chapter for further information on using jump codes.

(Selection): (Optional)

This field enables you to make a menu selection. Type a valid value (1 through 4), and press **Enter** to perform the selected function.

Separator Systems Options Maintenance Screen

EDIM935

Purpose

The Separator Systems Options Maintenance screen enables you to display and update the Separator Systems Options record. This record is located in the Separator Control file (EDIRSEP), with a key of all blanks.

How to Access

You can access the Separator Systems Options Maintenance screen in any of the following ways:

- From the Separator Main Menu, type **1** to select Separator Systems Options Maintenance and press **Enter**.
- From the Priority Options Directory screen, press **PF4=Option**.
- Type **7.5.1** in the Jump Code field of any screen and press **Enter**.

Screen Example

The following example illustrates the Separator Systems Options Maintenance screen.

```

EDIM935 7.5.1_____ SEPARATOR SYSTEMS OPTIONS MAINTENANCE   XXX 12/01/2005
                                                                12:00:00

Description.....: GENTRAN:CONTROL_SEPARATOR_SUBSYSTEM_____

X12 Interchange Program .....: EDIR931_      Key Usage Indicators
EDIFACT Interchange Program.....: EDIR932_      Test/Prod Use.....: Y
TRADACOMS Interchange Program.....: EDIR933_      Trn/Grp/Int Only..: T
User Interchange Program.....: EDISXIT_      Grp IDs Only.....: Y
Monitor Indicator/Store Sw.....: 1 / 1        Sndr/Rcvr Id Only.: Y
  Monitor Maintenance.....(630)...: _      DELETE PROCESSED DATA < TODAY'S DATE
    .....(631)...: _      DELETE ALL DATA < TODAY'S DATE
    .....(632)...: _      DELETE ALL DATA RECORDS
Trace Indicator.....: D          Router Parameters
Exception Program.....: EDIEXCP_      Max Start cnt.....: 10
TSQ Storage SW.....: M          Max Wait Time.....: 00 05

Error User Exit Program.....: _____
Error User Exit Data.....: _____
                          Last Update Date: 12/01/05 Time: 12:00:00 User: XXX

Enter PF1=Help          PF3=Exit PF4=Run Maint  PF5=Dir
                          PF10=Updt
  
```

Function Key Descriptions

- Note:** Standard function keys, such as **PF1=Help**, **PF3=Exit**, **PF7=Bwd**, **PF8=Fwd**, **PF12=Cancel**, and **PF15=Logoff**, as well as **Enter**, are defined in the Getting Started chapter of this guide.
- PF4=Run Maint** Runs the Separator Monitor Maintenance transaction (EDI1) using the parameter specified on the screen in the Monitor Maintenance fields. Select one of the three parameters and press **PF4=Run Maint** to run the maintenance in the background.
- PF5=Dir:** Displays the Priority Options Directory screen.
- PF10=Updt:** Updates the Separator Systems Options record.

Field Descriptions

(Jump Code): (Optional)

A 10-position alphabetic or numeric field containing the jump code for this screen. A screen's jump code is displayed automatically in the Jump Code field for that screen.

To *jump* to another screen, press **Home**, type the jump code of the screen to which you want to jump, then press **Enter**.

See "Jump Codes" earlier in this chapter for further information on using jump codes.

(Description): (Optional)

Two, 40-position (each line) alphanumeric fields that enable you to type or view a description of the Separator subsystem.

X12 Interchange Program: (Optional)

An 8-position alphanumeric field indicating the program that sets priority for the ASCX12 interchanges. The Gentran-supplied program is EDIR931.

Key Usage Indicators: (Required)

A group of fields that identify to the priority ID programs what parts of the envelope information (key usage indicators) to use in determining priority and process. Key usage indicators include the following nine items from the envelopes:

- Group Sender ID
- Interchange Sender ID
- Interchange Sender ID Qualifier
- Group Receiver ID
- Interchange Receiver ID
- Interchange Receiver ID Qualifier
- Test/Production Indicator (from the interchange)
- Transaction ID
- Functional Group ID

Test/Prod Use: (Required)

A 1-character alphabetic field indicating whether or not to use the Test/Production field of the Interchange Header record to determine priority. Valid values are:

- | | | |
|----------|---|---|
| Y | = | Yes, use the Test/Production field of the Interchange Header record and determine priority (this is the default value). |
| N | = | No, do not use the Test/Production field of the Interchange Header record and determine priority. |

Trn/Grp/Int Only: (Required)

A 1-character alphabetic field that indicates the level of detail to use in determining priority. Valid values are:

- | | | |
|----------|---|--|
| T | = | Use only the transaction in determining priority. If no transaction information is found, use the interchange (this is the default value). |
| G | = | Use only the functional group in determining priority. If no functional group information is found, use the interchange. |
| I | = | Use only the interchange in determining priority. |

Grp IDs Only: (Required)

A 1-character alphabetic field that indicates whether or not to use only the sender/receiver IDs from the group segments in determining priority. Valid values are:

- | | | |
|----------|---|---|
| Y | = | Yes, use only the sender/receiver IDs from the group segments. |
| N | = | No, use the sender/receiver IDs from both the group segments and the interchange ID segments. (Default value) |

Sndr ID Only: (Required)

A 1-character alphabetic field that indicates whether to use only the sender ID in determining priority. Valid values are:

- | | | |
|----------|---|---|
| Y | = | Yes, use only the sender ID. |
| N | = | Use both sender IDs and receiver IDs. (Default value) |

Use the following table to help you determine what values to type in the key usage indicator fields (Test/Prod Use, Trn/Grp/Int Only, Grp IDs Only, and Sndr ID Only), depending on what envelope information you want to use:

Key Usage Indicator Field	Value	Envelope Information Used
Test/Prod Use	Y	Test/Production Indicator
	N	(Do not use Test/Production Indicator; use Production only)
Trn/Grp/Int Only	T	Transaction ID (using sender and receiver from group and interchange), then Interchange
	G	Functional Group ID (using sender and receiver), then Interchange
	I	Interchange only: Interchange Sender ID Interchange Sender ID Qualifier Interchange Receiver ID Interchange Receiver ID Qualifier
Grp IDs Only	Y	Group Sender ID Group Receiver ID
	N	Group Sender ID Interchange Sender ID Interchange Sender ID Qualifier Group Receiver ID Interchange Receiver ID Interchange Receiver ID Qualifier
Sndr ID Only	Y	Group Sender ID Interchange Sender ID Interchange Sender ID Qualifier
	N	Group Sender ID Interchange Sender ID Interchange Sender ID Qualifier Group Receiver ID Interchange Receiver ID Interchange Receiver ID Qualifier

Note: Depending on the combination of key usage indicators you use, you can limit or expand the number of lookups in determining priority and process.

Note: Gentran:Control runs more efficiently with fewer lookups.

EDIFACT Interchange Program: (Optional)

An 8-position alphanumeric field indicating the program that sets priority for the EDIFACT interchanges. The Gentran-supplied program is EDIR932.

TRADACOMS Interchange Program: (Optional)

An 8-position alphanumeric field indicating the program that sets priority for the TRADACOMS interchanges. The Gentran-supplied program is EDIR933.

User Interchange Program: (Optional)

An 8-position alphanumeric field indicating the program that sets priority for user-defined headers and trailers, or all those not sent to the other three programs. Any program name is a valid value. The Gentran-supplied sample program is EDISXIT.

Monitor Indicator/Store Sw: (Required)

Two, 1-digit numeric fields indicating whether or not the Monitoring feature is turned on, and whether the Monitor program (EDIR940) will store the data.

In the first field, valid values are:

- | | | |
|----------|---|--|
| 1 | = | Yes, the Monitoring feature is turned on. |
| 0 | = | No, the Monitoring feature is not turned on (this is the default value). |

In the second field, valid values are:

- | | | |
|----------|---|--|
| 1 | = | Yes, store the data. |
| 0 | = | No, do not store the data (this is the default value). |

Monitor Maintenance (630): (Optional)

A 1-position field that instructs the system to run the maintenance transaction (EDI1) for the Separator Monitor files EDIRMNH and EDIRMNS. The 630 option instructs the maintenance program to delete all records with a return code of 00 that are one or more days old. Valid values are:

- | | | |
|--------------|---|---|
| Y | = | Yes, run the maintenance. |
| Note: | | You must press PF4=Run Maint to run maintenance. |
| N | = | No, do not run the maintenance. |
| Blank | = | No, do not run the maintenance. |

Monitor Maintenance (631): (Optional)

A 1-position field that instructs the system to run the maintenance transaction (EDI1) for the Separator Monitor files EDIRMNH and EDIRMNS. The 631 option instructs the maintenance program to delete all records that are one or more days old. Valid values are:

Y = Yes, run the maintenance.

Note: You must press **PF4=Run Maint** to run maintenance.

N = No, do not run the maintenance.

Blank = No, do not run the maintenance.

Monitor Maintenance (632): (Optional)

A 1-position field that instructs the system to run the maintenance transaction (EDI1) for the Separator Monitor files EDIRMNH and EDIRMNS. The 632 option instructs the maintenance program to delete all records. Valid values are:

Y = Yes, run the maintenance.

Note: You must press **PF4=Run Maint** to run maintenance.

N = No, do not run the maintenance.

Blank = No, do not run the maintenance.

Trace Indicator: (Required)

A 1-character alphabetic field used to set the system trace to print trace messages to the log. Valid values are:

E = Enabled. The system trace will print trace messages to the log.

D = Disabled. The system trace will not print trace messages to the log.

Trace determines the type of information written to the system log while this option is processed. When trace is disabled, only critical error messages are written to the log. When trace is enabled, optional processing information is written to the log, in addition to critical error messages.

Note: For production processing, disable trace so that critical error messages can be located easily. Enable trace during testing or when locating production errors.

Exception Program: (Optional)

An 8-position alphanumeric field indicating the name of the exception program. The sample program EDIEXIT1 shows how to create this program. If a different exception system is created, type the name of the CICS program that will process the bypassed data.

If an error occurs during processing, the data is passed to this exit. This program then can perform any necessary processing to store the data.

TSQ Storage SW: (Optional)

A 1-character alphabetic field that indicates what type of TSQ to use. Valid values are:

A	=	Use the auxiliary TSQ.
M	=	Use the main TSQ.
blank	=	Use the auxiliary TSQ (this is the default value).

Error User Exit Program: (Optional)

An 8-position alphanumeric field indicating the name of the user error message exit.

The user-supplied CICS program is linked to by the Separator subsystem when either a CICS system error or a data translation error occurs. This field provides automatic notification of errors within the system. For example, you can use this field so that the system automatically calls the appropriate personnel (e.g., calls a beeper) responsible for this part of the system.

Error User Exit Data: (Optional)

A 20-position alphanumeric field containing the error user exit data that is passed to the Error User Exit program if an error occurs during Gentran:Control processing.

The data is passed to the exit program, along with error information. If the same program is used for all error exits, the data can be used to identify the particular type of option that caused the error.

Router Parameters

A set of parameters used to control the start time of multiple processes. Router Parameters are established by information entered in the Max Start cnt and the Max Wait Time fields.

Max Start cnt: (Optional)

A 2-digit number that assigns the maximum number of processes Router program (EDIR945) may start from the Separator Driver or the Inbound or Outbound Splitter. The default number of tasks is 10.

Max Wait Time: (Optional)

Two, 2-digit fields that tell Router program (EDIR945) the amount of time (in minutes and seconds) to wait between processes. Values in each field are between 00 and 59. The default value for minutes is 00; the default value for seconds is 05.

See “Program Descriptions and Reports” in this guide for more information on Router program (EDIR945).

Last Update Date (Protected)

An 8-position field that displays the date on which the information on this screen was created or last changed. The date format is MM/DD/YY.

Last Update Time (Protected)

An 8-position field that displays the time at which the information on this screen was created or last changed. The time format is HH:MM:SS.

Last Update User (Protected)

A 3-position field that displays the initials of the user who created or last changed the information on this screen.

Priority Options Directory Screen

EDIM936

Purpose

The Priority Options Directory screen enables you to view the records used by the interchange router programs. The data for this screen is located on the Separator Control file (EDIRSEP).

How to Access

You can access the Priority Options Directory screen in any of the following ways:

- From the Separator Main Menu, type **2** to select Priority Options Directory and press **Enter**.
- From the Separator Systems Options Maintenance screen, press **PF5=Dir**.
- Type **7.5.2** in the Jump Code field of any screen and press **Enter**.

Screen Example

The following example illustrates the Priority Options Directory screen.

```

Select
EDIM936 7.5.2_____          PRIORITY OPTIONS DIRECTORY          XXX 12/01/2005
                                                                12:00:00

Starting Trans/Group id.....: _____

A  Trans/  Sender ID          Qual  Version  Test I/G/T
   Group  Receiver ID        Qual  Description  Prod  Ind

-
-  CONTRL          DEFAULT SEPARATION OPTI
-  DELHDR          UNO TEST - CONTRL UNG G
-  DELJIT          TRADACOMS DELHDR TEST D
-  INVOIC          EDIFACT DELJIT TEST DAT
                          T  T
                          EDIFACT INVOIC TEST DAT

Enter PF1=Help          PF3=Exit PF4=Option          PF5=Maint
      PF7=Bwd  PF8=Fwd

```

Screen Actions

The valid screen action is displayed on the top line of the Priority Options Directory screen. The following table describes the screen action and gives instructions on how to perform the action associated with it.

To Perform This Task	Using This Screen Action	Perform These Steps
Perform maintenance on a priority option.	Select	Type s in the A (Action Code) field of the priority option for which you want to perform maintenance, and press PF5 .

Function Key Descriptions

Note: Standard function keys, such as **PF1=Help**, **PF3=Exit**, **PF7=Bwd**, **PF8=Fwd**, **PF12=Cancel**, and **PF15=Logoff**, as well as **Enter**, are defined in the Getting Started chapter of this guide.

PF4=Option: Displays the Separator Systems Options Maintenance screen.

PF5=Maint: Displays the Priority Options Maintenance screen for a selected priority option.

Field Descriptions

(Jump Code): (Optional)

A 10-position alphabetic or numeric field containing the jump code for this screen. A screen's jump code is displayed automatically in the Jump Code field for that screen.

To *jump* to another screen, press **Home**, type the jump code of the screen to which you want to jump, then press **Enter**.

See "Jump Codes" earlier in this chapter for further information on using jump codes.

Starting Trans/Group id: (Optional)

An 8-position alphanumeric field indicating the first transaction or group ID that you want to view.

A (Action Code): (Optional)

A 1-character alphabetic field in which you indicate the action you want to perform. The top line of the screen lists the valid action. The valid action for the Priority Options Directory screen is Select. To execute an action, type **s** in the **A** (Action Code) field of the option you want to select, then press the appropriate **PF** key.

For example, if you want to perform maintenance on a particular priority option, type **s** in the **A** (Action Code) field for the option, then press **PF5=Maint**.

See *Function Key Descriptions* in this section for descriptions of valid functions you can perform for the Priority Options Directory screen.

Trans/Group: (Protected)

A 6-position alphanumeric field indicating the transaction ID or group functional ID of the inbound data.

Sender ID: (Protected)

A 35-position alphanumeric field indicating the sender ID of the inbound data.

Qual: (Protected)

A 4-position alphanumeric field indicating the sender ID qualifier of the inbound data.

Version: (Protected)

A 12-position alphanumeric field indicating the version of the inbound data.

Test/Prod: (Protected)

A 1-character alphabetic field designating the test/production indicator for the interchange. Valid values are:

T	=	Test
P	=	Production

I/G/T Ind: (Protected)

A 1-character alphabetic field indicating the identifier for the inbound data.
Valid values are:

I	=	Interchange
G	=	Group
T	=	Transaction

Receiver ID: (Protected)

A 35-position alphanumeric field indicating the receiver ID of the inbound data.

Qual: (Protected)

A 4-position alphanumeric field indicating the receiver ID qualifier of the inbound data.

(Description): Protected

A 23-position alphanumeric field that describes the Separator record, as entered on the Priority Options Maintenance screen.

Priority Options Maintenance Screen

EDIM937

Purpose

The Priority Options Maintenance screen enables you to enter the parameters used by the interchange router programs to identify the processing characteristics for a given set of data. The records are located in the Separator Control file (EDIRSEP).

How to Access

You can access the Priority Options Maintenance screen in any of the following ways:

- From the Separator Main Menu, type **3** to select Priority Options Maintenance, and press **Enter**.
- From the Priority Options Directory screen, type an **s** in the A (Action Code) field of the Trans/Group ID you want to view and press **PF5=Maint**.
- Type **7.5.3** in the Jump Code field of any screen and press **Enter**.

Screen Example

The following example illustrates the Priority Options Maintenance screen.

```

EDIM937 7.5.3_____  PRIORITY OPTIONS MAINTENANCE  XXX 12/01/2005
                                                                12:00:00

** K E Y S **
Trans/Group ID.....: INVOIC
Sender ID / Qual.....: _____ / _____
Receiver ID / Qual.....: _____ / _____
Version.....: _____
Test/Prod Ind.....: T
Int/Grp/Trans Ind.....: T

Description.....: EDIFACT_INVOIC_TEST_DATA_____

System Image...: EDI  Program Image...: EDI
  Realtime Immediate Option.....: _____
  Queue File Number.....: 005  CONTROL INSTALLATION VERIF
User Application Program.....: _____
Basic Separator Split file.....: 003
Priority.....: 5
                    Last Update Date: 00/00/00 Time: 00:00:00 User: SCI

Enter PF1=Help          PF3=Exit PF4=Dir          PF5=QOpt
      PF7=Bwd  PF8=Fwd  PF9=Add PF10=Updt PF11=Del

```

Function Key Descriptions

Note: Standard function keys, such as **PF1=Help**, **PF3=Exit**, **PF7=Bwd**, **PF8=Fwd**, **PF12=Cancel**, and **PF15=Logoff**, as well as **Enter**, are defined in the Getting Started chapter of this guide.

- PF4=Dir:** Displays the Priority Options Directory screen.
- PF5=QOpt:** Displays the Queue Options Maintenance screen for the specific Queue File Number displayed on the screen.
- PF9=Add:** Adds the record you are displaying to the Separator Control file.
- PF10=Updt:** Updates the record you are displaying to the Separator Control file.
- PF11=Del:** Deletes the record you are displaying, in two steps: the first time you press **PF11** the system confirms that the record exists on Separator Control file. The second time you press **PF11** the system deletes the record.

Field Descriptions

(Jump Code): (Optional)

A 10-position alphabetic or numeric field containing the jump code for this screen. A screen's jump code is displayed automatically in the Jump Code field for that screen.

To *jump* to another screen, press **Home**, type the jump code of the screen to which you want to jump, then press **Enter**.

See "Jump Codes" earlier in this chapter for further information on using jump codes.

Trans/Group ID: (Optional)

A 6-position alphanumeric field indicating the transaction ID or group ID of the inbound data.

Sender ID/Qual: (Optional)

Two alphanumeric fields (one, a 35-position field; the other, a 4-position field) indicating the sender ID and the sender ID qualifier, respectively, of the inbound data.

Receiver ID/Qual: (Optional)

Two alphanumeric fields (one, a 35-position field; the other, a 4-position field) indicating the receiver ID and the receiver ID qualifier, respectively, of the inbound data.

Version: (Optional)

A 12-position alphanumeric field indicating the version of the inbound data.

Test/Prod Ind: (Required)

A 1-character alphabetic field designating the test/production indicator for the interchange. Valid values are:

T	=	Test
P	=	Production

Int/Grp/Trans Ind: (Required)

A 1-character alphabetic field that indicates the identifier for the inbound data. Valid values are:

I	=	Interchange
G	=	Group
T	=	Transaction

(Description) (Optional)

A 40-position alphanumeric field that describes the Separator record.

System Image: (Optional)

A 3-position alphanumeric field that indicates the system image for the immediate option or the Queue file number.

Note: You can use the program image and system image to send data from one release of Gentran:Control to another.

Program Image: (Optional)

A 3-position alphanumeric field that indicates the program image for the immediate option or the Queue file number.

Note: You can use the program image and system image to send data from one release of Gentran:Control to another.

Realtime Immediate Option: (Optional)

Note: This option is available only for systems with Gentran:Realtime installed.

A 3-digit numeric field indicating the Gentran:Control immediate option number used to process the data. Valid values are **200** through **399**.

(Realtime Immediate Desc): (Display only)

A 25-character field that displays the description for the Immediate Option. This description is entered on the Gentran:Realtime Immediate Options Maintenance screen.

Queue File Number: (Optional)

A 3-digit numeric field indicating the Gentran:Control Queue file number to which the data is sent. Valid values are **001** through **999** (online source only).

(Queue Description): (Display only)

A 25-character field that displays the description for the queue file option. This description is entered on the Queue Options Maintenance screen.

User Application Program: (Optional)

An 8-position alphanumeric field indicating the name of the user-written program that receives the data. Any program name is a valid value.

Basic Separator Split File

A 3-digit numeric field indicating the Gentran:Basic split file number to which the data is to be sent. Valid values are 001 – 100.

Note: This number is used to identify the ddname that will receive the data during the Separator batch processing. For example, 004 indicates that SYS004 will receive the data.

Note: This is only available for systems with Gentran:Basic installed.

Priority: (Required)

A 1-digit numeric field indicating the order in which you want to process this particular set of documents. Valid values are **1** through **9**.

Last Update Date (Protected)

An 8-position field that displays the date on which the information on this screen was created or last changed. The date format is MM/DD/YY.

Last Update Time (Protected)

An 8-position field that displays the time at which the information on this screen was created or last changed. The time format is HH:MM:SS.

Last Update User (Protected)

A 3-position field that displays the initials of the user who created or last changed the information on this screen.

Separator Monitor Screen

EDIM938

Purpose

The Separator Monitor screen enables you to view the entries in the Monitor Header file (EDIRMNH).

How to Access

You can access the Separator Monitor screen in any of the following ways:

- From the Separator Main Menu, type **4** to select Separator Monitor and press **Enter**.
- Type **7.5.4** in the Jump Code field of any screen and press **Enter**.

Screen Example

The following example illustrates the Separator Monitor screen.

```

EDIM938 7.5.4_____ SEPARATOR MONITOR          XXX 12/01/2005
                                           12:00:00

Date...: _____ Time...: _____

Date      Time      Task #   Opt  User Pgm   Prty  Error Stat  Desc
First Record
20010306  10413700  0001234  005          5    08  08  DEFAULT SEPARAT
NO DATA AVAILABLE
20010306  10413700  0001234  003          5    16  06  USER SUPPLIED I
NO DATA AVAILABLE
20010306  10413700  0001234  003          5    16  06  USER SUPPLIED I
NO DATA AVAILABLE
20010306  10573900  0001344  005          5    08  08  DEFAULT SEPARAT
NO DATA AVAILABLE
20010306  10573900  0001344  005          5    08  08  USER SUPPLIED I
NO DATA AVAILABLE
20010709  10000800  0001046  010          3    01  01  TRADACOMS DELHD
NO DATA AVAILABLE

Enter PF1=Help          PF3=Exit
      PF7=Bwd  PF8=Fwd
  
```

Function Key Descriptions

Note: Standard function keys, such as **PF1=Help**, **PF3=Exit**, **PF7=Bwd**, **PF8=Fwd**, **PF12=Cancel**, and **PF15=Logoff**, as well as **Enter**, are defined in the Getting Started chapter of this guide.

Field Descriptions

(Jump Code): (Optional)

A 10-position alphabetic or numeric field containing the jump code for this screen. A screen's jump code is displayed automatically in the Jump Code field for that screen.

To *jump* to another screen, press **Home**, type the jump code of the screen to which you want to jump, then press **Enter**.

See "Jump Codes" earlier in this chapter for further information on using jump codes.

Date: (Optional)

An 8-position alphanumeric field indicating the starting date for the monitor display. Type the date in YYYYMMDD format.

Time: (Optional)

A 6-position alphanumeric field indicating the starting time for the monitor display. Type the time in HHMMSS format.

Date: (Protected)

An 8-position alphanumeric field containing the date on which the data was processed through the Monitor program (either from the Separator or the Splitter program). The date is in YYYYMMDD format.

Time: (Protected)

A 6-position alphanumeric field containing the time the data was processed through the Monitor program (either from the Separator or the Splitter program). The time is in HHMMSS format.

Task #: (Protected)

A 7-digit numeric field containing the task number for which the Monitor program was run.

Opt: (Protected)

A 3-digit numeric field containing the option that the Priority program found for processing the data.

Note: This value represents either the Gentran:Realtime immediate option number or the Queue file number.

User Pgm: (Protected)

An 8-position alphanumeric field containing the user program that the Priority program found for processing the data.

Prty: (Protected)

A 1-digit numeric field indicating the priority that the Priority program found for processing the data.

Error: (Protected)

A 2-digit numeric field containing the error level returned from either the Gentran:Realtime process, the Queue file write, or the user program.

Stat: (Protected)

A 2-digit numeric field containing the status code returned from either the Gentran:Realtime process, the Queue file write, or the user program.

Note: An error level 01 and status code 01 implies that the process has begun but has not yet completed. Either the data is still being processed, or the process abended and was not able to update the monitor Error and Stat fields.

Desc: (Protected)

A 15-position alphanumeric field containing the description for the process. (This description was entered on the Priority ID Options screen.)

First Record: (Protected)

A 71-position alphanumeric field containing the first record (usually the interchange header) that was stored with the data. If the data is not stored on the Monitor storage file, then the message **NO DATA AVAILABLE** displays in this field.

Program Descriptions

Overview

This chapter contains the following topics related to programs in Gentran:Control for zSeries Release 6.4:

Topic	Page	
Utility Control Card Format	4-3	
Multi-queue Read Subroutine.....EDIRCMR	4-4	
Multi-queue Write Subroutine.....EDIRCMW	4-5	
Queue File Maintenance.....EDIEQMT	4-6	
Queue Read.....EDIRQRD.....	4-9	
Batch Wait Utility.....EDIWAITD	4-14	
Asynchronous Program	EDIRASYN	4-15
System Status Toggle program.....EDIETOGL.....	4-18	
Queue Write	EDIRQWR.....	4-19
Remote Single-queue Read Subroutine.....EDIERSR.....	4-24	
Sample Queue Read.....EDIESQR.....	4-30	
Remote Single-queue Write Subroutine.....EDIERSW.....	4-31	
Sample Queue Write.....EDIESQW	4-36	
Online Output Gateway.....EDIEOOG.....	4-37	
.....EDIEOQW.....		
.....EDIROQW.....		
Online Input Gateway.....EDIEOIG	4-46	
.....EDIEOQR.....		
.....EDIROQR.....		
Exception Exit	EDIEXIT1.....	4-53
Online Error User Exit.....EDIEXIT2.....	4-56	
Online Batch Initiator	EDIEOBI	4-59
Online Scanner/Initiator	EDIEOSI.....	4-60
Automatic System Start-Up.....EDIEPLT	4-62	
Sample Online Application	EDIESOA	4-63
Separator Gateway.....EDIR100	4-64	
Separator Driver	EDIR930	4-66
X12 Interchange Priority Lookup.....EDIR931	4-68	
EDIFACT Interchange Priority Lookup.....EDIR932	4-69	

TRADACOMS Interchange Priority Lookup.....	EDIR933	4-70
Monitor Input/Output	EDIR940	4-71
Router	EDIR945	4-72
Application Log Interface.....	EDIR999	4-73

Utility Control Card Format

Control cards function as overrides to default values contained in the programs. These program defaults are used when no control cards are specified, or when an individual criteria is not included in the control cards. If an empty control card file is supplied, the defaults are used.

Control cards consist of two parts: a request and parameters for the request. The terms *requested operation* and *criteria* are used in describing control cards. A requested operation is the specific logical process (e.g., format, read, write, etc.) that the program is to perform during this execution. Criteria are specific options (e.g., a filename, queue file number, etc.) that the program is to use when performing its requested operation.

Control cards must adhere to the following rules:

- Comment cards can appear in any order and are denoted by an asterisk in column one.
 - All control cards must be in upper case.
 - Each control card request consists of one requested operation and several operation criteria.
 - The requested operation must be on the first non-comment card.
 - The criteria can consist of any number of value cards.
 - The name of the criteria begins in column 3 and the value to match begins in column 35. Criteria are specified one per card, and can be in any order.
 - Except when noted, the criteria all must be true.
 - All criteria names must be in capitals, with dashes separating multi-word criteria names.
 - Only one requested operation can be specified per run.
- Note:** A few programs are exceptions to this rule; if a program supports multiple requested operations, then this characteristic is indicated in the program description.

Multi-Queue Read Subroutine

EDIRCMR

The Multi-Queue Read subroutine (EDIRCMR) is a batch program used to read even- and odd-numbered queue files.

Operation

The Multi-Queue Read subroutine is called by the Queue Read program (EDIRQRD); it cannot be executed as a stand-alone program. This program's functions include the following:

- Opening and closing queue files.
- Reading the queue file specified in its parameters.
- Deblocking the records stored on the queue file.
- Passing individual records to the calling program.
- Updating the pointers on the queue file upon successful completion.

Inputs

The following table describes the inputs for the Multi-Queue Read program.

DDname	Description
EDIQInnn	Queue file (where <i>nnn</i> is the queue file number)

Outputs

The records that are read off the queue file are passed back to the Queue Read batch program.

Multi-Queue Write Subroutine

EDIRCMW

The Multi-Queue Write subroutine (EDIRCMW) is a batch program to write to even- and odd-numbered queue files.

Operation

The Multi-Queue Write subroutine is called by the Queue Write program (EDIRQWR); it cannot be executed as a stand-alone program. This program's functions include the following:

- Opening and closing queue files.
- Formatting (blocking) application records onto queue file records.
- Writing queue file records.
- Updating the pointers on the queue file.

Inputs

The Batch Write program passes the individual records to EDIRCMW, which writes them on the queue file.

Outputs

The following table describes the output for the Multi-Queue Write program.

DDname	Description
EDIQInnn	Queue file (where <i>nnn</i> is the queue file number)

Queue File Maintenance

EDIEQMT

The Queue File Maintenance batch program (EDIEQMT) initializes queue files for use with Gentran:Control. This process involves filling the file with records containing low-values (hexadecimal values of zero). When a boundary violation or the count parameter indicates that the file has become full, the first two records are updated with control information. The control information consists of the record counts, pointers, dates, times, and other internal information.

Operation

The Queue File Maintenance program runs as a batch job step. Sample JCL to run this program is located in member EXECQMT in the JCL library.

Inputs

The following table describes the inputs for the Queue File Maintenance program.

DDname	Description
EDICNTL	Control Card File
EDIQF	Queue File
ERRCTL	Error Message and Control File
EDICFG	System Configuration File

Outputs

One queue file is the only significant output. In addition, the Checkpoint file is updated.

DDname	Description
EDIQF	Queue file (formatted)
EDICKP	Checkpoint file (updated)

Reports

The following table describes reports created by this program.

DDname	Description
EDISUM	Processing Summary Report
EDILOG	Processing Log Report

Report 1: Processing Summary Report

The Processing Summary report is contained in the EDISUM output file. The report lists all criteria used, the results of processing, and fatal error conditions, if any exist.

The following example illustrates a portion of the Processing Summary report.

```
REPORT DATE: 12/01/2005                GENTRAN:CONTROL                PAGE   : 00001
REPORT TIME: 12:00:00                  QUEUE FILE MAINTENANCE          VERSION: 6.4
REPORT ID  : EDIEQMT-EDISUM            SUMMARY REPORT

      OPTIONS USED THIS RUN
      -----

REQUESTED-OPERATION                    =  FORMAT
QUEUE-FILE-NUMBER                      =   843
QUEUE-RECORD-COUNT                     =   5802

      PROCESSING SUMMARY
      -----

RECORDS FORMATTED                      :     5,801
NUMBER OF ERRORS THIS RUN               :           0
HIGHEST RETURN CODE THIS RUN           :           0
```

Report 2: Processing Log Report

The Processing Log report is contained in the EDILOG output file. The report is created by the subroutine EDILOG, which is included in the Gentrans:Basic system.

The following example illustrates a portion of the Processing Log report.

```
REPORT DATE: 12/01/2005                GENTRAN:CONTROL                PAGE   : 00001
REPORT TIME: 12:00:00                  QUEUE FILE MAINTENANCE          VERSION: 6.4
REPORT ID  : EDIEQMT-EDILOG            PROCESSING LOG                  COMPILE DATE:12/01/05

      MESSAGES
      -----

EDI-010701-I 00 QUEUE FILE MAINTENANCE PROCESSING BEGINS . . . DATE: 12/01/2005, TIME: 12:00:00
EDI-009021-I 00 CHECK-POINT NOW INACTIVE . . . DATE: 12/01/2005, TIME: 12:00:00
EDI-010702-I 00 QUEUE FILE MAINTENANCE PROCESSING ENDS . . . . DATE: 12/01/2005, TIME: 12:00:00
```

Control Card Options*Operations*

Position	Length	Format	Field Name	Values/Edits
01 – 06	06	AN	Operation file	FORMAT
07 – 80	74	AN	Filler	spaces

*Operation Criteria***Queue File Identification Criteria (Required)**

Position	Length	Format	Field Name	Values/Edits
01 – 02	02	AN	Filler	spaces
03 – 34	32	AN	Operation Criteria	QUEUE-FILE Valid values are: 001 – 999
35 – 37	03	ZD	Queue file number	Required
39 – 47	09	ZD	Record count	Optional Default: 999999999 (which implies that the program will process until a boundary violation is reached)
48 – 80	33	AN	Filler	spaces

Queue Read

EDIRQRD

The Queue Read batch program (EDIRQRD) reads either application data or EDI data from even- and odd-numbered queue files.

Operation

Control cards enable the Queue Read program to read input transactions from one or multiple queue files. Sample JCL to run this program is located in member EXECQRD in the JCL library.

Inputs

The Queue Read program reads either application data or EDI data.

DDname	Description
EDICNTL	Control Card File
EDIQInnn	Queue File (where: nnn is the number that you specify on the control card)
ERRCTL	Error Message and Control File
EDIOCF	Online Control File
EDICFG	System Configuration File

Outputs

The Queue Read program outputs a variable-length or fixed-length sequential file which contains either application or EDI data. The characteristics of the file must be identified in the control card criteria.

DDname	Description
EDIOUS	Output data (DDname can be altered via control cards)
EDIQInnn	Queue file (pointers are updated) (where <i>nnn</i> is the number that you specify on the control card)
EDICKP	Checkpoint file (updated)

Reports

The following table describes the reports created by this program.

DDname	Description
EDISUM	Processing Summary Report
EDILOG	Processing Log Report

Report 1: Processing Summary Report

The Processing Summary report is contained in the EDISUM output file. The report displays the processing results for the execution, the number of records read, and the return code for the execution.

A return code of 4 indicates that the queue file contains no data. A fatal error causes a return code of 8 or greater during processing.

The following example illustrates the Processing Summary report.

```

REPORT DATE: 12/01/2005          GENTRAN:CONTROL          PAGE   : 00001
REPORT TIME: 12:00:00          BATCH QUEUE READ        VERSION: 6.4
REPORT ID  : EDIRQRD-EDISUM    SUMMARY REPORT

```



```

      OPTIONS USED THIS RUN
      -----
REQUESTED-OPERATION           = READ

```

```

INPUT DDNAME                  = EDIQI001
OUTPUT DDNAME                 = EDIOU1
OUTPUT FILE TYPE              = V
OUTPUT FILE LRECL            = 2044
QUEUE FILE NUMBER             = 024

```



```

RECORDS READ FROM Q FILE: 024.....:      330
RECORDS WRITTEN TO FILE: EDIOU1...:      330

```



```

      PROCESSING SUMMARY
      -----
NUMBER OF RECORDS READ FROM QUEUES :      330

```



```

NUMBER OF ERRORS THIS RUN      :      0
HIGHEST RETURN CODE THIS RUN  :      0

```

Report 2: Processing Log Report

The Processing Log report is contained in the EDILOG output file. The report contains information and error messages; it is created by the subroutine EDILOG, which is included in the Gentran:Basic system.

The following example illustrates the Processing Log report.

```

REPORT DATE: 12/01/2005          GENTRAN:CONTROL          PAGE   : 00001
REPORT TIME: 12:00:00          BATCH QUEUE READ        VERSION: 6.4
REPORT ID  : EDIRQRD-EDILOG    PROCESSING LOG          COMPILE DATE: 12/01/05

  MESSAGES
  -----

EDI-010104I 00 CENTRAL BATCH QUEUE FILE READ BEGINS . . . DATE: 12/01/2005, TIME: 12:00:00
EDI-009021I 00 CHECK-POINT NOW INACTIVE . . . DATE: 12/01/2005, TIME: 12:00:00
EDI-010105I 00 CENTRAL BATCH QUEUE FILE READ ENDS . . . DATE: 12/01/2005, TIME: 12:00:00

```

Special JCL Requirements

DD statements for each queue file specified in the control cards are required. The DDname should be in the format EDIQInnn, where *nnn* is the number specified on the control card. Default output is to the file EDIOUT, but this destination can be changed on the control cards.

Note: *nnn* must be a number from 001 to 100. This number is *not* related to the internal Queue file number.

Control Card Options

Control cards specify which queue files are to be read by EDIRQRD. Up to 50 QUEUE-FILE control cards can be specified. Only those queue files specified are processed. Prior to specifying which queue files to read, you must specify the process to be performed. Specify the process by entering **READ** in columns one through four of the first control card.

Operations

Position	Length	Format	Field Name	Values/Edits
01 – 04	04	AN	Operation	READ
05 – 80	76	AN	Filler	spaces

Operation Criteria

Position	Length	Format	Field Name	Values/Edits
01 – 02	02	AN	Filler	spaces
03 – 29	27	AN	Queue identifier	QUEUE-FILE-NUMBER
30 – 37	08	ZD	Queue file DD name	EDIQInnn Note: nnn must be a number in the range of 001 – 100.
38 – 38	01	AN	Filler	spaces
39 – 44	06	AN	Output file name	Optional Default=EDIOUT
45 – 45	01	AN	Filler	spaces
46 – 46	01	AN	Output file Record format	V or F Default=V
47 – 47	01	AN	Filler	spaces
48 – 53	06	ZD	Output file LRECL	Six-digit number Default=002040 Maximum is 008000
54 – 54	01	AN	Filler	spaces
55 – 57	01	ZD	Internal queue file number	A 3-digit number that represents the queue file number

Example

```
//EDIQI001 DD DSN=GENTRAN.V6X4.CTL.VSAM.EDIQ789,
//          DISP=SHR
//EDIQI002 DD DSN=GENTRAN.V6X4.CTL.VSAM.EDIQ601,
//          DISP=SHR
//EDIQI003 DD DSN=GENTRAN.V6X4.CTL.VSAM.EDIQ024,
//          DISP=SHR
//EDIQI004 DD DSN=GENTRAN.V6X4.CTL.VSAM.EDIQ754,
//          DISP=SHR
//EDIQI001 DD DSN=GENTRAN.V6X4.SEQ.QFOUT1,
//          DISP=(MOD,CATLG),UNIT=SYSDA,
//          SPACE=(TRK,(5,5)),DCB=(LRECL=2044,RECFM=VB,BLKSIZE=2048)
//EDIQI002 DD DSN=GENTRAN.V6X4.SEQ.QFOUT2,
//          DISP=(MOD,CATLG),UNIT=SYSDA,
//          SPACE=(TRK,(5,5)),DCB=(LRECL=80,RECFM=FB,BLKSIZE=7200)
//EDIQI003 DD DSN=GENTRAN.V6X4.SEQ.QFOUT3,
//          DISP=(MOD,CATLG),UNIT=SYSDA,
//          SPACE=(TRK,(5,5)),DCB=(LRECL=250,RECFM=FB,BLKSIZE=7500)
//EDICNTL DD *
READ
QUEUE-FILE      EDIQI001 EDIOU1 V 002044 789
QUEUE-FILE      EDIQI002 EDIOU2 F 000080 601
QUEUE-FILE      EDIQI003 EDIOU1 V 002044 024
QUEUE-FILE      EDIQI004 EDIOU3 F 000250 754
```

Marker	Description
1.	The queue file defined with DDname EDIQI001 is read.
2.	The data read from EDIQI001 is written to a queue file with the DDname EDIOU1.
3.	The queue file defined by EDIQI001 is assigned an internal queue file number of 789.

Batch Wait Utility

EDIWAITD

The Batch Wait Utility program is used to delay the execution of batch programs that must close/deallocate the online files for maintenance until all online activity has ended and the system has been disabled.

Operation

The JCL to execute this program can be found in the JCL member EXECWAIT

Processing

The EDIWAITD program reads the OCF file and checks the system status. If the system status is “Q”, it goes into a wait state for an interval equal to the scanner interval, and repeats the check until the system has been disabled.

An optional input parameter enables you to indicate a maximum wait time in seconds. This allows you to limit the length of time that the EDIWAITD program will wait. If the maximum wait time is exceeded, the program ends with a return code of 8.

There are three return codes: 0=System is now disabled, 8=Maximum wait interval exceeded, and 16=System is enabled (e.g. it will not become disabled without intervention). EDIWAITD must run after the EDIX transaction (program EDIETOGL) has been started. The EDIX transaction can be started manually by entering it on a CICS screen or from a batch step. EDIWAITD must be executed before other steps that will use the online files. Subsequent steps should check for the 0 return code before executing.

Input

Name	Description
EDIOCF	Online Control
SYS030	Input Parameter

Output

This program produces no output.

Control Card Options

Control cards specify the maximum wait time this program will wait.

Position	Length	Format	Field Name	Values/Edits
01 – 11	11	AN	Operation	MAXTIME=
12 – 15	4	AN	Max Wait Time in Seconds	Numeric value between 0000 and 9999 to indicate the maximum wait time for the EDIWAITD program

Asynchronous Program

EDIRASYN

The Asynchronous Gateway (EDIRASYN) links to the Online Output Gateway (EDIEOOG), the Separator Gateway (EDIR100), the Outbound Application Gateway (EDIR101) or the Inbound Communication Gateway (EDIR103) to run either queue file output, the separator subsystem or the translation process asynchronously from the users' applications.

Note: To use the Outbound Application Gateway and Inbound Communication Gateway, Gentran:Realtime must be installed.

Operation

User interface programs that would have linked to these Gateways (EDIEOOG, EDIR100, EDIR101, and EDIR103) can issue a START on transaction EDIA that runs the Asynchronous Gateway.

Overview

User interface programs that would have linked to the Gateways can use the Asynchronous Gateway instead. The user interface does not have to wait for the translation process to complete when using this gateway. This also provides the ability for a user program to initiate queue writes and translations in a different CICS region.

Interface Processing Logic

The processing logic the interface program must use with the Gateway is described here. The user interface program STARTS the transaction EDIA and passes it to the parameters described below.

The interface program creates a Temporary Storage Queue containing the record for the document group.

The interface program initializes the Gateway's parameter list and STARTs the EDIA transaction.

The Asynchronous Gateway will retrieve the passed parameter list and will LINK to the Gateway identified in the list.

The Asynchronous Gateway will delete the Temporary Storage Queue created in Step 1.

Parameters

The Gateway interface programs will use a short list of parameters that will identify to the Gateway what processing options should be used. A copybook member (EDIRAGCA) has been provided with Gentran:Control that can be used in your interface programs.

Values Passed to Realtime Gateways (EDIR101 and EDIR103)

<u>Record Position</u>	<u>Length</u>	<u>Format</u>	<u>Field Name</u>
0001 – 0008	8	AN	Gateway Name
0009 – 0011	3	AN	System image ID
0012 – 0019	8	AN	name of TS Queue
0020 – 0022	3	AN	Immediate Number
0023 – 0137	115	AN	Filler 1
0138 – 0217	80	AN	User Pass Thru Area
0218 – 0248	31	AN	Filler 2

Values Passed to Control Gateways (EDIR100 and EIDEEOG):

<u>Record Position</u>	<u>Length</u>	<u>Format</u>	<u>Field Name</u>
0001 – 0008	8	AN	Gateway Name
0009 – 0011	3	AN	System Image ID
0012 – 0014	3	AN	Queue file number (or 600 for separator)
0015 – 0022	8	AN	name of TS Queue
0023 – 0024	2	AN	Filler
0025 – 0025	1	AN	Batch init indicator
0026 – 0248	223	AN	Filler

Field Descriptions*Values Passed to Gateway:***Gateway Name:**

An 8-character field that holds the Gateway program name that the Asynchronous Gateway is to LINK to. Valid values are: **EDIEOOG**, **EDIR100**, **EDIR101**, and **EDIR103**.

Note: If a program image other than EDI is being used, then change the names to reflect the program image.

The value must be set by the user interface program to process either queue file writing. Separator subsystem, Outbound translation or Inbound translation.

System Image

A 3-character code indicating the System Image ID. Valid values are any three alphanumeric characters (First character must be alphabetic).

The value EDI is entered to your System Image if it is different than EDI. This value is required.

In the CICS environment, a 3-character System Image ID is used to identify all files belonging to particular “system image”. All file DD names, CICS enqueue names, and so on, are prefixed by this 3-character System Image ID.

Name of TS Queue

The 1-to-8-character name of the Temporary Storage Queue to be processed by Gentran:Control. This TSQ is where the user program has stored the data.

Immediate or Schedule Number (only for Realtime translations)

The 3-digit identifier for the Immediate or Schedule request options to be used by Gentran:Realtime for processing the Temporary Storage Queue. This number must be in the range 200-499.

Queue file number:

The 3-digit identifier for the queue file option to be used by Gentran:Control processing the Temporary Storage Queue. This identifies the queue file name that the data will be written to. When the separator gateway (EDIR100) is being executed, the queue file number should be 600.

Batch init indicator:

A 1-position field indication whether or not EDIEOOG will initiate batch processing immediately upon completion of the document group. Valid values are:

Y	=	Yes; initiate batch processing immediately upon completion of this document group.
N	=	No; do not initiate batch processing immediately upon completion of this document group.

Filler 1

A 115-character field that must be all spaces (work area used by the asynchronous gateway).

User Pass Thru Area

An 80-character alphanumeric field used to pass user information from the user program to the Gentran:Realtime data translation process. This area is passed to all user exit program (all Mapper exits require the Parm Exit Version to be set to 2) and to the user destination programs. Any changes or modifications made to this area by these exits are passed through also. The program that originally started the translation receives all changes made during the process.

Filler 2

A 31-character field that must be all spaces.

Interface Design Considerations

The same design considerations for EDIEOOG, EDIR100, EDIR101, and EDIR103 must be taken into account for the Asynchronous Gateway. Plus, additional considerations are provided below.

The Asynchronous Gateway deletes the TSQ passed from the user interface program. If the Gateway Name passed is not EDIEOOG, EDIR100, EDIR101 or EDIR103, no data is processed and error message is sent to the Online Log File.

A sample program EDIRAGSP demonstrates the conventions used to start the Asynchronous Gateway.

System Status Toggle Program

EDIETOGL

The System Status Toggle program is used to toggle the System status. This process allows the system to be shut down gracefully allowing active processing to complete before the system is disabled. This process can also be used to START (enable) a system that has been stopped (disabled).

Operation

The program is executed by the EDIX transaction and is used by batch processes to shutdown the system for maintenance and then restart the system after the maintenance has been performed. The customer adds two steps around their maintenance job. Each step executes a utility program that starts the EDIX transaction in the CICS region.

Note: The specific utility program is site dependant. You should consult your systems programmers to determine the utility to use.

To ensure shutdown and restart of the system, parameters can be included with the transaction. If **EDIX-X** is entered then the Toggle program will always change the system status to disabled and stop the system. If **EDIX-S** is entered then the Toggle program will always change the system status to enabled and start the system. **EDIX** with no parameters always toggles between enabled and disabled.

Processing

The program checks the current status of the system and then sets the status according to the parameters supplied with it, and then starts the EDII transaction (which runs the Online Scanner Initiator: EDIEOSI).

Files Used

Input

Name	Description
EDICFGQ	Configuration tsq

Output

Name	Description
EDIOCF	Online Control file
EDIICF	In-Core Control file

Queue Write**EDIRQWR**

The Queue Write batch program (EDIRQWR) writes either application data or EDI data to any queue file by calling the Multi-Queue Write subroutine (EDIRCMW). The queue file must be defined with the source as Batch (see screen EDIM303).

Operation

Control cards enable the Queue Write program to write output transactions to a queue file. Sample JCL to run this program is located in member EXECQWR in the JCL library.

Inputs

The following table describes inputs for the Queue Write program.

DDname	Description
EDICNTL	Control Card File
EDIIN	Input data (use control card to modify the DD name)
ERRCTL	Error Message and Control File
EDICFG	System Configuration File
EDIOCF	Online Control File

Note: Data can be either application data or EDI data, but not both.

Outputs

Output for the Queue Write program is a queue file which contains either application data or EDI data.

DDname	Description
EDIQOnnn	Queue file (pointers are updated) (where <i>nnn</i> is the number you specify on the control card.)
EDICKP	Checkpoint file (updated)

Reports

The reports created by this program are.

DDname	Description
EDISUM	Processing Summary Report
EDILOG	Processing Log Report

Report 1: Processing Summary Report

The Processing Summary report is contained in the EDISUM output file. The report displays the options used for the execution, the number of records read, and the return code for the execution.

A return code of 4 indicates that the Input file contains no data. A fatal error causes a return code of 8 or greater during processing.

The following example illustrates the Processing Summary report.

```

REPORT DATE: 12/01/2005                GENTRAN:CONTROL                PAGE   : 00001
REPORT TIME: 12:00:00                 BATCH QUEUE WRITE              VERSION: 6.4
REPORT ID  : EDIRQWR-EDISUM           SUMMARY REPORT

```

```

      OPTIONS USED THIS RUN
      -----

```

```

REQUESTED-OPERATION                    = WRITE
-----
OUTPUT QUEUE-FILE-DDNAME                = EDIQO001
INPUT FILE NAME                         = EDIIN2
INPUT FILE TYPE                          = V
INPUT FILE LRECL                        = 2044
QUEUE-FILE-NUMBER                       = 002
-----
OUTPUT QUEUE-FILE-DDNAME                = EDIQO002
INPUT FILE NAME                         = EDIIN
INPUT FILE TYPE                          = V
INPUT FILE LRECL                        = 2044
QUEUE-FILE-NUMBER                       = 024
-----
OUTPUT QUEUE-FILE-DDNAME                = EDIQO007
INPUT FILE NAME                         = EDIIN
INPUT FILE TYPE                          = V
INPUT FILE LRECL                        = 2044
QUEUE-FILE-NUMBER                       = 199

```

```

TOTAL RECORDS READ FROM EDIIN2          :      68
TOTAL RECORDS WRITTEN TO 002            :      68
TOTAL RECORDS READ FROM EDIIN          :      80
TOTAL RECORDS WRITTEN TO 024            :      80
TOTAL RECORDS READ FROM EDIIN          :      80
TOTAL RECORDS WRITTEN TO 199            :      80
      PROCESSING SUMMARY
      -----
TOTAL # OF RECS WRITTEN TO QUEUES       :      228

```

```

NUMBER OF ERRORS THIS RUN                :      0
HIGHEST RETURN CODE THIS RUN            :      0

```

Report 2: Processing Log Report

The Processing Log report is created by the subroutine EDILOG, which is included in the Gentran:Basic system.

The following example illustrates the Processing Log report.

```

REPORT DATE: 12/01/2005          GENTRAN:CONTROL          PAGE   : 00001
REPORT TIME: 12:00:00          BATCH QUEUE WRITE      VERSION: 6.4
REPORT ID  : EDIRQWR-EDILOG    PROCESSING LOG         COMPILE DATE: 12/01/05
  MESSAGES
  -----

EDI-010116I 00 CENTRAL BATCH QUEUE FILE WRITE BEGINS . . . DATE: 12/01/2005, TIME: 12:00:00
EDI-009021I 00 CHECK-POINT NOW INACTIVE . . . DATE: 12/01/2005, TIME: 12:00:00
EDI-010117I 00 CENTRAL BATCH QUEUE FILE WRITE ENDS . . . DATE: 12/01/2005, TIME: 12:00:00

```

Special JCL Requirements

DD statement for the queue file specified in the control cards is required. The DDname should be in the format EDIQOnnn, where 'nnn' is the number specified in the control card. An additional 150K of region size also is required. Default input is from the file EDIIN, but this DDname can be changed on the control cards.

Control Card Options

Control cards specify which queue file to write. Only one queue file is processed. Prior to specifying the queue file to write, you must specify the process to be performed by entering WRITE in columns one through five of the first control card.

Operations

Required

Position	Length	Format	Field Name	Values/Edits
01 – 05	05	AN	Operation	WRITE
06 – 80	75	AN	Filler	spaces

*Operation Criteria***Required**

Position	Length	Format	Field Name	Values/Edits
01 – 02	02	AN	Filler	spaces
03 – 29	27	AN	Queue file identifier	QUEUE-FILE
30 – 37	08	AN	Queue file DD Name	EDIQOnnn 3-digit number Required
38 – 38	01	AN	Filler	spaces
39 – 44	06	AN	Input file name	DD name of input data Default= EDIIN
45 – 45	01	AN	Filler	spaces
46 – 46	01	AN	Input file RECFM	V or F Default= V
47 – 47	01	AN	Filler	spaces
48 – 53	06	ZD	Input file LRECL	Six digit number Default= 002040 Maximum= 8000
54 – 54	01	AN	Filler	spaces
55 – 57	03	ZD	Internal Queue file number	A 3-digit number that represents the queue file number

Example

```

//EDIQ001 DD DSN=GENTRAN.V6X4.CTL.VSAM.EDIQ824,
//
//EDIQ002 DD DSN=GENTRAN.V6X4.CTL.VSAM.EDIQ017,
//
//EDIIN DD DSN=INPUT.FILE.ONE,
//
//EDIIN2 DD DSN=INPUT.FILE.TWO,
//
//EDICNTL DD *
WRITE
  QUEUE-FILE
  QUEUE-FILE

```

2 1 3

```

EDIQ001 EDIIN F 000080 824
EDIQ002 EDIIN2 F 000250 017

```

Marker	Description
1.	The data in the file defined with the DDname EDIIN is read.
2.	The data written to a queue file with a DDname of EDIQ001.
3.	The queue file defined by EDIQ001 is assigned an internal queue file number of 824.

Remote Single-queue Read Subroutine

EDIERSR

The Remote Single-queue Read subroutine (EDIERSR) is a batch program that enables batch applications to read even-numbered queue files created by Gentran:Control.

Operation

The Remote Single-Queue Read subroutine is called by user-supplied programs executing in a batch environment. The Sample Queue Read (EDIESQR) program demonstrates the use of the EDIERSR subroutine.

See the section “Sample Queue Read EDIESQR” in this chapter for program description information.

The Remote Single-queue Read subroutine cannot be executed as a standalone program.

Inputs

The following table describes inputs for the Remote Single-queue Read program.

DDname	Description
EDIQF	Queue File
ERRCTL	Error Message and Control File

Outputs

The following table describes outputs for the Remote Single-queue Read program.

DDname	Description
EDIQF	Queue File (pointers are updated)
EDICKP	Checkpoint File (updated)

Reports

The following table describes reports created by this program.

DDname	Description
EDILOG	Processing Log Report

Report 1: Processing Log Report

The Processing Log report is created by the subroutine EDILOG, which is included in the Gentran:Basic system.

The following example illustrates a portion of the Processing Log report.

```

REPORT DATE: 12/01/05                GENTRAN:CONTROL                PAGE   : 00001
REPORT TIME: 12:00:00                REMOTE SINGLE QUEUE READ        VERSION: 6.4
REPORT ID  : EDIERSR-EDILOG          PROCESSING LOG                  12/01/2005

MESSAGES
-----

EDI-010951-I 00 REMOTE SINGLE QUEUE READ PROCESSING BEGINS . . . DATE: 12/01/05, TIME: 12:00:00
EDI-010952-I 00 REMOTE SINGLE QUEUE READ PROCESSING ENDS . . . DATE: 12/01/05, TIME: 12:00:00

```

Special JCL Requirements

Application job steps using the Remote Single-Queue Read subroutine must include the following DD statements:

```

//EDICKP    DD    DSN=.....EDICKP,DISP=SHR

//EDIQF     DD    DSN=.....EDIQnnn,DISP=SHR
              (where 'nnn' is the even number of the queue file to be read.)

//EDILOG    DD    SYSOUT=*

```

Control Card Options

None for this program; all requests and criteria are passed through the call interface from the user-supplied calling program.

Call Interface Description

The Remote Single-queue Read subroutine is a batch interface. The program receives application data and EDI data from the batch translation system via the queue file process for even-numbered queue files. Thus, inbound applications and outbound communications may use this subroutine to receive application data and EDI data respectively from the Gentran:Basic system.

EDIERSR functions as an input/output routine with one exception. Calls are made to the subroutine to open the queue file, read a record, and close the queue file. One additional function call is used to commit all previous reads. The Commit function may be issued only on document group boundaries, and enables job steps to be check-pointed by the user program.

See the Glossary for a definition of check-point.

Control Structure

The control structure for calling EDIERSR follows.

1. The user application calls EDIERSR to perform the following functions:
2. EDIERSR initializes for processing (e.g., open files).
3. EDIERSR reads a record image from the queue file and returns with either one record image or a “no queue data” indication (analogous to End-of-File). An Initialization function must have been previously completed successfully.
4. EDIERSR terminates (e.g., close files). An Initialization function must have been previously completed successfully.
5. EDIERSR commits all previous records read as being processed. If the run terminates without a Commit being issued, then the queue file remains intact (as if the records never were read). A Commit function may be issued only between document group boundaries.

Parameters

The parameters for the Remote Single-queue Read program follow.

Position	Length	Format	Field Name
Control Values to Subroutine			
0001 – 0001	1	AN	Entry Point
Control Values Returned			
0002 – 0003	2	AN	Status Code
0004 – 0005	2	AN	Error Level
0006 – 0105	100	AN	Return Message
Values to Subroutine			
0106 – 0108	3	ZD	Queue File Number
Values Returned			
0109 – 0109	1	AN	End of Queue Ind.
0110 – 0110	1	AN	Begin Document Ind.
0111 – 0111	1	AN	End Document Ind.
0112 – 0113	2	BIN	Record Length
0114 – 2153	8000	AN	Record Image

COBOL Layout

The COBOL layout for the interface parameters is located in the Sample Queue Read program (EDIESQR) in the Gentran:Control library: GENTRAN.V6X4.CTL.UTILITY.SOURCE.

The following example illustrates a sample COBOL communication area layout.

```

*
*  REMOTE SINGLE QUEUE READ - COMM AREA INTERFACE LAYOUT
*
01  LRSR-COMMAREA.
    05  LRSR-CONTROL-VALUES-TO-Q-READ.
        10  LRSR-ENTRY-POINT                PIC X(01).
            88  LRSR-EP-INITIALIZATION      VALUE '1'.
            88  LRSR-EP-READ-RECORD        VALUE '2'.
            88  LRSR-EP-COMMIT              VALUE '8'.
            88  LRSR-EP-TERMINATION         VALUE '9'.
    05  LRSR-CONTROL-VALUES-RETURNED.
        10  LRSR-STATUS-CODE                PIC X(02).
        10  LRSR-ERROR-LEVEL                PIC X(02).
        10  LRSR-RETURN-MESSAGE            PIC X(100).
    05  LRSR-INFO-TO-Q-READ.
        10  LRSR-QUEUE-FILE-NUMBER         PIC 9(03).
    05  LRSR-RETURN-FIELDS-RETURNED.
        10  LRSR-END-OF-FILE-IND           PIC X(01).
            88  LRSR-END-OF-FILE-YES       VALUE 'Y'.
        10  LRSR-BEGIN-DOCUMENT-GROUP-IND PIC X(01).
            88  LRSR-BEGIN-DOCUMENT-GROUP-YES VALUE 'Y'.
        10  LRSR-END-DOCUMENT-GROUP-IND   PIC X(01).
            88  LRSR-END-DOCUMENT-GROUP-YES VALUE 'Y'.
        10  LRSR-RECORD-LENGTH             PIC 9(04) COMP.
        10  LRSR-RECORD-IMAGE              PIC X(8000).

    05  FILLER                              PIC X(20).

```

Field Description (Control Value Passed)

Entry Point:

A 1-position numeric field indicating the function for which you are calling EDIERSR.
Valid values are:

1	=	Initialize
2	=	Read
8	=	Commit
9	=	Terminate

Field Descriptions (Control Values Returned)

Status Code:

A 2-position numeric field indicating the success or failure of the requested function.
Valid values are:

00	=	Function completed successfully.
16	=	Function failed.

Error Level:

A 2-position numeric field indicating the highest error level that occurred in the subroutine. A value of "00" indicates no errors occurred.

Return Message:

A 1- to 100-position numeric field containing the textual message of any error encountered by EDIERSR.

Field Description (Value Passed)**Queue File Number:**

A 3-position numeric field displaying the even queue file number. The document group is obtained from this queue file.

Field Descriptions (Values Returned)**End of File Ind:**

A 1-position alphabetic field indicating to the calling program when the end of file has been reached. Valid values are:

Y	=	Yes; the end of file has been reached.
N	=	No; the end of file has not been reached.

Begin Document Ind.:

A 1-position alphabetic field indicating whether or not this is the first record in the document group. Valid values are:

Y	=	Yes; this is the first record in the document group.
N	=	No; this is not the first record in the document group.

End Document Ind.:

A 1-position alphabetic field indicating whether or not this is the last record in the document group. Valid values are:

Y	=	Yes; this is the last record in the document group.
N	=	No; this is not the last record in the document group.

Record Length:

A 2-byte binary value field indicating the length of the record image returned.

Record Image:

A 1- to 8000-position numeric field containing the returned record.

Interface Design Considerations

Familiarize yourself with the following information before designing interface programs to the Remote Single-queue Read program.

Inbound Application Interface Considerations

- A document group contains all records for the application.
- The application must be coded to be capable of handling errors returned from the EDIERSR. The status code and error level must be examined separately. The status code indicates whether or not the current function completed successfully, and the error level indicates the highest error that occurred.
- The application (when in control) may terminate without affecting the queue file. Any document group data passed to the application that has not been committed remains on the queue file.

Outbound Communication Interface Considerations

- The considerations for inbound applications described in the previous section also apply to outbound applications, with the following difference: a document group contains one or more interchanges.
- For ease of communication recovery, the Commit function can be used to follow the Unit of Work grouping of the communication session.

Sample Queue Read

EDIESQR

The Sample Queue Read batch program (EDIESQR) demonstrates how a batch program can read an even-numbered queue file containing data from the Gentran:Basic system. The sample program uses the Remote Single-Queue Read Subroutine (EDIERSR) to access the queue file.

The Sample Queue Read program can be used to create sequential files of application data or EDI data. The program does not distinguish between application and EDI data, therefore, the Sample Queue Read program is used in the same manner for both types of data.

COBOL source code for this program is located in the Gentran:Control Source Library (GENTRAN.V6X4.CTL.UTILITY.SOURCE).

Operation

The Sample Queue Read program reads data from Queue File 2 and writes it to a sequential file.

Special JCL Requirements

The sample program requires the following DD statements in addition to those required by EDIERSR, for the user-defined output data file:

```
//EDIMTF    DD    DSN=..... .MTFDATA,  
//          DCB=(LRECL=512,RECFM=FB,...),...
```

See member **EXECSQR** in the *JCL library* for additional JCL requirement information.

Remote Single-queue Write Subroutine

EDIERSW

The Remote Single-queue Write subroutine (EDIERSW) is a batch program that enables batch applications to write to odd-numbered queue files, which are input to Gentran:Control.

Operation

The Remote Single-queue Write subroutine can be called by user-supplied programs executing in a batch environment. The Sample Queue Write program (EDIESQW) demonstrates the use of the EDIERSW subroutine.

See the section “Sample Queue Write EDIESQW” in this chapter for program description information.

EDIERSW cannot be executed as a standalone program.

Inputs

The following table describes inputs for the Remote Single-queue Write program.

DDname	Description
EDIQF	Queue File (pointers are read)
ERRCTL	Error Message and Control File

Outputs

The following table describes outputs for the Remote Single-queue Write program.

DDname	Description
EDIQF	Queue File
EDICKP	Checkpoint File (updated)

Reports

The following table describes reports created by this program.

DDname	Description
EDILOG	Processing Log Report

Report 1: Processing Log Report

The Processing Log report is created by the subroutine EDILOG, which is included in the Gentran:Basic system.

The following example illustrates a portion of the Processing Log report.

```

REPORT DATE: 12/01/05                GENTRAN:CONTROL                PAGE   : 00001
REPORT TIME: 12:00:00                REMOTE SINGLE QUEUE WRITE        VERSION: 6.4
REPORT ID  : EDIERSW-EDILOG          PROCESSING LOG                    (12/01/05)

MESSAGES
-----

EDI-010976-I 00 REMOTE SINGLE QUEUE WRITE PROCESSING BEGINS . . . DATE: 12/01/05, TIME: 12:00:00
EDI-010977-I 00 REMOTE SINGLE QUEUE WRITE PROCESSING ENDS . . . DATE: 12/01/05, TIME: 12:00:00

```

Special JCL Requirements

Application job steps using the Remote Single-Queue Write subroutine must include the following DD statements:

```

//EDICKP      DD    DSN=.....EDICKP,DISP=SHR

//ERRCTL      DD    DSN=.....ERRCTL,DISP=SHR

//EDIQF       DD    DSN=.....EDIQnnn,DISP=SHR
                  (where 'nnn' is the odd number of the queue file to be
                  written)

//EDILOG      DD    SYSOUT=*

```

Control Card Options

None for this program; all requests and criteria are passed through the Call Interface of the user-supplied program.

Call Interface Description

The Remote Single-queue Write subroutine is a batch interface. The program sends application data and EDI data to the batch translation system via the queue file process for odd-numbered queue files. Thus, outbound applications and inbound communications may use EDIERSW to send application data and EDI data respectively to Gentran:Basic.

EDIERSW functions as an input/output routine with one exception. Calls are made to EDIERSW to open the queue file, write a record, and close the queue file. One additional function call is used to commit all previous writes. The Commit function may be issued only on document group boundaries; the Commit function enables job steps to be check-pointed by the user program.

Control Structure

The control structure for calling EDIERSW follows.

1. The user application calls EDIERSW to perform the following functions:
2. EDIERSW initializes for processing (e.g., open files).
3. EDIERSW writes a record image to the queue file and returns with either a successful completion or error indication. An Initialization function must have been completed successfully previously.
4. EDIERSW terminates (e.g., close files). An Initialization function must have been completed successfully previously.
5. EDIERSW commits all previous records written. If the run terminates without a Commit being issued, the queue file remains intact (as if the records were never written). A Commit function should be issued only between document group boundaries.

Parameters

The parameters for the Remote Single-queue Write subroutine follow.

Position	Length	Format	Field Name
Control Values to Subroutine			
0001 – 0001	1	AN	Entry Point
Control Values Returned			
0002 – 0003	2	AN	Status Code
0004 – 0005	2	AN	Error Level
0006 – 0105	100	AN	Return Message
Values to Subroutine			
0106 – 0108	3	ZD	Queue File Number
0109 – 0109	1	AN	Begin Document Ind.
0110 – 0111	2	BIN	Record Length
0112 – 2151	8000	AN	Record Image

COBOL Layout

The COBOL layout for the interface parameters is located in the Sample Queue Write program (EDIESQW) in the Gentran:Control library: GENTRAN: V6X4.CTL.UTILITY.SOURCE.

The following example illustrates a sample COBOL communication area layout.

```

*
*  REMOTE SINGLE QUEUE WRITE - COMM AREA INTERFACE LAYOUT
*
01  LRSW-COMMAREA.
05  LRSW-CONTROL-VALUES-TO-Q-WRITE.
     10  LRSW-ENTRY-POINT                PIC X(01).
           88  LRSW-EP-INITIALIZATION VALUE '1'.
           88                                VALUE '2'.
           88  LRSW-EP-COMMIT            VALUE '8'.
           88  LRSW-EP-TERMINATION      VALUE '9'.
05  LRSW-CONTROL-VALUES-RETURNED.
     10  LRSW-STATUS-CODE                PIC X(02).
     10  LRSW-ERROR-LEVEL                PIC X(02).
     10  LRSW-RETURN-MESSAGE            PIC X(100).
05  LRSW-VALUES-TO-Q-WRITE.
     10  LRSW-QUEUE-FILE-NUMBER         PIC 9(03).
     10  LRSW-BEGIN-DOCUMENT-GROUP-IND  PIC X(01).
     10  LRSW-RECORD-LENGTH             PIC 9(04)COMP.
     10  LRSW-RECORD-IMAGE              PIC X(8000).
05  FILLER                              PIC X(20).

```

Field Description (Control Values Passed)

Entry Point:

A 1-position numeric field indicating the function for which you are calling EDIERSW.
Valid values are:

1	=	Initialize
2	=	Write
8	=	Commit
9	=	Terminate

Field Descriptions (Control Values Returned)

Status Code:

A 2-position numeric field indicating the success or failure of the requested function.
Valid values are:

00	=	Function completed successfully.
08	=	Queue file full.
16	=	Function failed.

Error Level:

A 2-position numeric field indicating the highest error level that occurred in EDIERSW. A value of 00 indicates no errors occurred.

Return Message:

A 1- to 100-position numeric field containing a textual message of any error encountered by EDIERSW.

Field Descriptions (Values Passed)**Queue File Number:**

A 3-position numeric field indicating the number of the odd-numbered queue file to which the document group is written.

Begin Document Ind.:

A 1-position alphanumeric field indicating whether or not this is the first record in the document group. Valid values are:

Y	=	Yes; this is the first record in the document group
N	=	No; this is not the first record in the document group

Record Length:

A 2-byte numeric, binary value field indicating the length of the record image to be written. The length must be greater than zero and less than 8000.

Record Image:

A 1- to 8000-position numeric field containing the record to write.

Interface Design Considerations

Familiarize yourself with the following information before designing interface programs to the Remote Single-queue Write program.

Outbound Application Interface Considerations

- A document group may consist of one or more documents.
- The application must be coded to be capable of handling errors returned from EDIERSW. The status code and error level must be examined separately. The status code indicates whether or not the current function completed successfully, and the error level indicates the highest error that occurred.
- The application (when in control) may terminate without affecting the queue file. Any records passed to EDIERSW since the last Commit function are discarded.

Inbound Communication Interface Considerations

- The considerations for Outbound Applications described in the previous section also apply to inbound applications, with the following difference: a document group may contain one or more interchanges.
- For ease of communication recovery, the Commit function can be used to follow the Unit of Work grouping of the communication session.

Sample Queue Write

EDIESQW

The Sample Queue Write batch program (EDIESQW) demonstrates how a batch program can write data to queue files which are input to Gentran:Control. The sample program uses the Remote Single-Queue Write subroutine (EDIERSW) to access the queue file.

EDIESQW can be used to load a queue file from a sequential file containing application data or EDI data. The Sample Queue Write program does not distinguish between application and EDI data, therefore, the program is used in the same manner for both types of data.

COBOL source code for EDIESQW is contained in the Gentran:Control Source Library GENTRAN.V6X4.CTL.UTILITY.SOURCE.

Operation

The Sample Queue Write program reads data from a sequential file and writes it to queue file 1.

Special JCL Requirements

The program requires the following DD statement in addition to those required by EDIERSR:

```
//EDIMTF DD DSN=..... .MTFDATA,DISP=SHR
```

See member **EXECSQW** in the *JCL library* for additional JCL requirement information.

Online Output Gateway

EDIEOOG
EDIEOQW
EDIROQW

The Online Output Gateway (EDIEOOG) is an application interface that sends application data and EDI data to the batch translation system for processing. Thus, outbound applications and inbound communications may use this Gateway to send application data and EDI data respectively to Gentran:Basic. The Online Output Gateway does not distinguish between application and EDI data; therefore, the Gateway is used in the same manner for both types of data.

Note: The Online Output Gateway uses the Online Queue Write subprogram (EDIEOQW or EDIROQW) to complete the writes to the queue file. Since the Online Output Gateway and the Online Queue Write programs are interdependent, “Online Output Gateway” is the term normally used to refer to the set of programs.

Operation

Figure 4.17 illustrates a simplified overview of Online Output Gateway operation. The numbers in the illustration correspond to the steps below the figure that describe the operation.

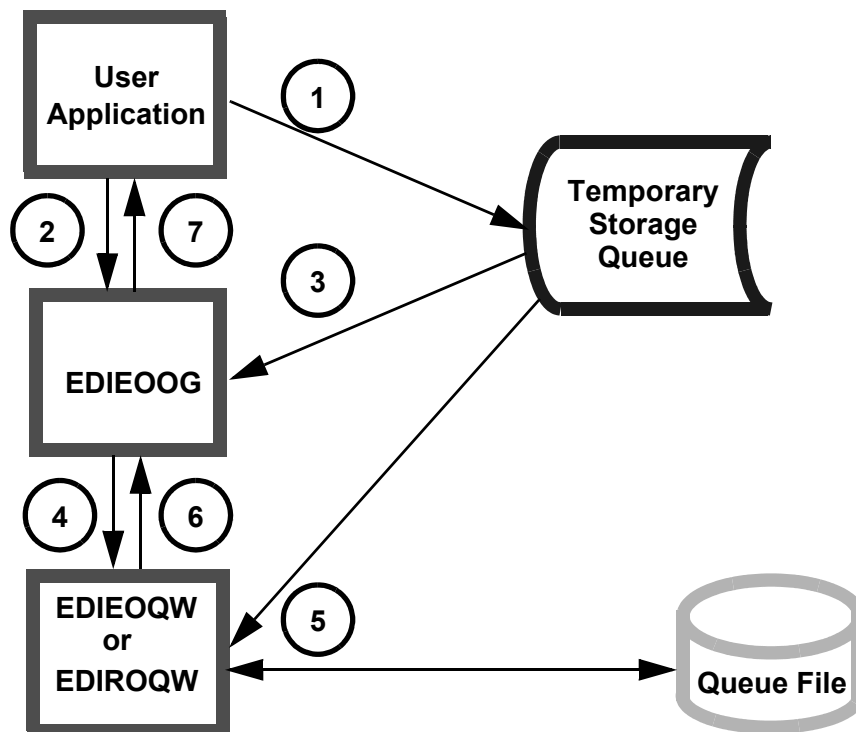

Figure 4.17 Online Output Gateway Operation

The following steps describe Online Output Gateway operation.

1. The user application creates a Temporary Storage Queue (TSQ) containing the record images (application or EDI data) that represent a desired document group.
2. The program links to the Online Output Gateway, indicating that the TSQ is a complete Unit of Work.
3. The Online Output Gateway reads the TSQ for verification of the data and checks the parameters sent by the user application.
4. The Online Output Gateway links to the Online Queue Write program (EDIEOQW or EDIROQW).

Note: EDIEOQW writes to odd numbered queue files and EDIROQW writes to even numbered queue files. The EDIEOOG program controls this processing so the user application only needs to link to the gateway to write to either queue file sets.

5. The Online Queue Write program reads the TSQ, then updates the queue file that is specified in the communication link area passed from the user application.
6. The Online Queue Write program returns to the Online Output Gateway, with a status code, an error level, and a message reflecting the successful or unsuccessful completion of the write.
7. The Online Output Gateway passes the status code, error level and message information back to the user application.

Note: CICS limits the number of records that can be written to a TSQ to no more than 32,767 records. If you have a large transaction involving a number of records greater than the limit, then you must set indicators within the communication link area passed to EDIEOOG to tell the program that the Unit of Work is split onto multiple TSQs.

This process can be accomplished in one of two methods: multiple links to EDIEOOG (one for each TSQ) with the appropriate indicators set for each link, or chain the TSQs to each other by using a special record that provides the name of the next TSQ. See Example B and Example C in this section for information on how these methods are used.

Inputs

The following tables describe inputs for the Online Output Gateway program.

TSQ	Description
EDICFGQ	Configuration File TSQ
EDIICF	Control File TSQ
EDIQ nnn	Queue File header TSQ (where nnn is the queue file number)
TSQname	The name of the TSQ identified in the communication link area from user program

DDname	Description
EDIQ nnn	Queue File
EDICKP	Checkpoint File
EDIOCF	Online Control File

Outputs

The following tables describe outputs for the Online Output Gateway program.

TSQ	Description
EDIQ nnn	Queue file header TSQ (where nnn is the queue file number)

DDname	Description
EDIQ nnn	Queue file

Control Structure

The procedures and techniques used to communicate with the Online Output Gateway are known as the *control structure*. The user application must pass the data to the Gateway program by linking to it and passing a communication area. Passing the communication area tells the Gateway where to find the data, which queue file to write the data to, whether or not the data is complete, and whether or not a batch process is to be initiated immediately. After the link, the user application must verify that the process was successful by checking the status code and error level.

Examples of the control structure process follow:

Example A.

The document group contains less than 32,767 records.

1. The user application creates a TSQ containing the records for the document group.
2. The user application initializes the parameter list to the Gateway and then links to the Gateway. The document group indicators are set to indicate both the beginning and end of the document group.
3. After the Gateway has completed, control returns to the user application. The user application examines the status code to determine whether the document group was accepted by the Gateway, and examines the error level to determine whether or not any errors were encountered (if errors are encountered, the user application takes appropriate action as specified within the program).
4. The user application deletes the TSQ created in the first step.

Example B.

The document group contains more than 32,767 records.

1. The user application creates a TSQ containing the first part of the document group.
2. The user application initializes the parameter list to the Gateway and then links to the Gateway. The document group indicators are set by the Gateway to indicate the beginning, but not the end, of the document group.
3. After the Gateway has processed, control returns to the user application. The user application examines the status code to determine whether the document group was accepted by the Gateway, and examines the error level to determine if any errors were encountered (if errors are encountered, the user application takes appropriate action written for error conditions).
4. The user application deletes the TSQ created in the first step.

5. The user application creates a TSQ containing the next part of the document group, and links to the Gateway, indicating that the document group neither begins nor ends on this link. Upon return, the user application checks the status code and error level as before and deletes the TSQ.

This process repeats until the last part of the document group is processed. On the link for the last part of the document group, the user application indicates that the document group ends.

Note: The entire document group must be processed in one CICS task (e.g., the user application must start and end the document group in the same CICS task).

Example C.

The document group contains more than 32,767 records.

1. The user application creates a TSQ containing the first part of the document group and inserts an eye catcher record that identifies the next TSQ that holds the continued data. The format of the eye catcher is Col 1-7 = '###TSQ=', Col 8-15 = TSQname. This can continue until all the data is stored on multiple TSQs.

Note: There is no specific location that the eye catcher must be written but obviously it cannot be greater than the 32,767th record.

2. The user application initializes the parameter list to the Gateway and then links to the Gateway. The TSQ name in the parameter list must be the first TSQ created. The document group indicators are set by the Gateway to indicate the beginning, and the end, of the document group (i.e. Begin Document Ind = 'Y' and End Document Ind = 'Y').
3. After the Gateway has processed, control returns to the user application. The user application examines the status code to determine whether the document group was accepted by the Gateway, and examines the error level to determine if any errors were encountered (if errors are encountered, the user application takes appropriate action written for error conditions).
4. The user application deletes the TSQs created in the first step.

Parameters

The parameters for the Online Output Gateway are described below. The source for this layout is located in the member EDIEOGCA in the library GENTRAN.V6X4.CTL.UTILITY.SOURCE.

Position	Length	Format	Field Name	Value
Control Values Passed to Gateway from Application				
01 – 03	3	AN	System Image ID	
04 – 06	3	ZD	Queue File Number	Queue File (must be defined with a source of Online)
07 – 14	8	AN	Name of TS Queue	
15 – 15	1	AN	Begin Document Ind.	Y or N
16 – 16	1	AN	End Document Ind.	Y or N
17 – 17	1	AN	Init. Batch Process Ind.	Y or N
Control Values Returned to Application from Gateway				
18 – 19	2	AN	Error Level	
20 – 21	2	AN	Status Code	
22 – 121	100	AN	Return Message	

Field Descriptions (Passed Fields)

System Image ID:

A 3-position alphanumeric field indicating which Gentran:Control system image is to be used. The default System Image ID is “EDI.”

Note: If a COMMAREA shorter than 121 characters is passed to the Online Output Gateway, an “EDIL” abend is issued.

Queue File Number:

A 3-position numeric field indicating the queue file number of the queue file to which the document group is added.

Note: The queue file can be an odd or even number between 001 and 999. It must be defined with a source of Online.

Name of TS Queue:

A 1- to 8-position alphabetic field containing the name of the TSQ to be processed by the Online Output Gateway.

Begin Document Ind.:

A 1-position alphanumeric field indicating whether or not the TSQ contains the beginning of this document group. Valid values are:

Y	=	Yes; the TSQ contains the beginning of this document group.
N	=	No; the TSQ does not contain the beginning of this document group.

End Document Ind.:

A 1-position field indicating whether or not the TSQ contains the end of this document group. Valid values are:

Y	=	Yes; the TSQ contains the end of this document group.
N	=	No; the TSQ does not contain the end of this document group.

Init. Batch Process Ind.:

A 1-position field indicating whether or not EDIEOOG will initiate batch processing immediately upon completion of this document group. Valid values are:

Y	=	Yes; initiate batch processing immediately upon completion of this document group.
N	=	No; do not initiate batch processing immediately upon completion of this document group.

Do not set this value to Y unless the value in the End Document Ind. field also is set to Y. If you request batch processing, you must enter a value of B in the Action to Initiate field on the Queue Options Maintenance screen for this queue file.

The "Batch JCL Name" entered on the Queue Options Maintenance screen tells EDIEOOG what JCL to submit.

Field Descriptions (Returned Fields)**Error Level:**

A 2-position numeric field indicating the highest error level that occurred in the Gateway or any of its subfunctions. A value of 00 indicates that no errors occurred. All other values denote an error.

Status Code:

A 2-position numeric field indicating the success or failure of the requested function.
Valid values are:

01	=	Document group accepted for batch processing.
04	=	Document group accepted but batch initiation was not successful.
06	=	Document group rejected; queue file not online write.
08	=	Document group rejected; queue file full.
10	=	Document group rejected; queue file disabled.
12	=	Document group rejected; queue file not defined.
16	=	Document group rejected; the return message contains the error encountered.

Note: The status codes 06, 08, 10, 12, and 16 are accompanied by an error level of 16.

Note: When processing a large document group without using TSQ chaining, the system only returns a status code 01 with an error level 00 on the final TSQ (when the value in the End Document Indicator field is set to Y). The successful processing of all the other intermediate TSQs (when the value in the End Document Indicator field is set to N) returns a status code 16 with an error level 00.

Return Message:

A 1- to 100-position alphanumeric textual message describing any error encountered by the Gateway or its subfunctions.

Interface Design Considerations

Familiarize yourself with the following information before designing interface programs to the Online Output Gateway.

Outbound Application Interface Considerations

- Outbound applications link to the Online Output Gateway to send application data to the Gentran:Basic system.
- The TSQ contains application record images that may have trailing spaces truncated (e.g., the record length may be variable). Each record must be between 1 and 8000 bytes in length.
- A document group normally is an individual document unless you need to make a series of documents into a Unit of Work. Once accepted by the Gateway, a document group is available immediately for batch processing.

- If a document group exceeds 32,767 records, then multiple links to the Online Output Gateway are required to complete the document group. The Gateway holds the queue file through the series of links until the user application indicates that the document group ends. The application transaction must begin and end the document group within the same CICS task. If the user application finds that it cannot complete the document group, then it is forced to terminate the current CICS task (in order to release the queue file).
- Access to an individual queue file is serialized. In particularly busy systems, the user application should be designed to operate asynchronously from the rest of the application so as not to cause the rest of the application to serialize processing.
- The user application must be coded to handle errors returned from the Gateway. The status code and error level must be examined separately. The status code indicates whether or not the current function completed successfully, and the error level indicates the highest error that occurred. Both a successful status code and non-zero error level may occur (e.g., the function completed successfully, but an error was detected in subsequent processing logic).
- The user application (when in control) may terminate without affecting the queue file. In this case, any partial document group passed to the Gateway is discarded, and the queue file is freed by CICS during task termination.

Inbound Communication Interface Considerations

- The considerations for outbound applications described in the previous section also apply to inbound applications, with the following differences:
 - A. The TSQ contains record images of EDI data.
 - B. A document group may contain one or more interchanges.
- For ease of communication recovery, the document group may follow the Unit of Work grouping of the communication session (e.g., the batch transmitted during a given communication session).

Online Input Gateway

**EDIEOIG
EDIEOQR
EDIROQR**

The Online Input Gateway (EDIEOIG) is an application interface that receives application data and EDI data from the batch translation system for processing. Thus, inbound applications and outbound communications may use the Online Input Gateway to receive application data and EDI data respectively from the Gentran:Basic system. The Online Input Gateway does not distinguish between application and EDI data; therefore, the Gateway is used in the same manner for both types of data.

Note: The Online Input Gateway uses the Online Queue Read subprogram (EDIEOQR or EDIROQR) to complete the queue reads from the queue file. Since the Online Input Gateway and the Online Queue Read programs are interdependent, “Online Input Gateway” is the term normally used to refer to both programs.

Operation

Figure 4.18 illustrates a simplified overview of Online Input Gateway operation. The numbers in the illustration correspond to the steps below the figure that describe the operation.

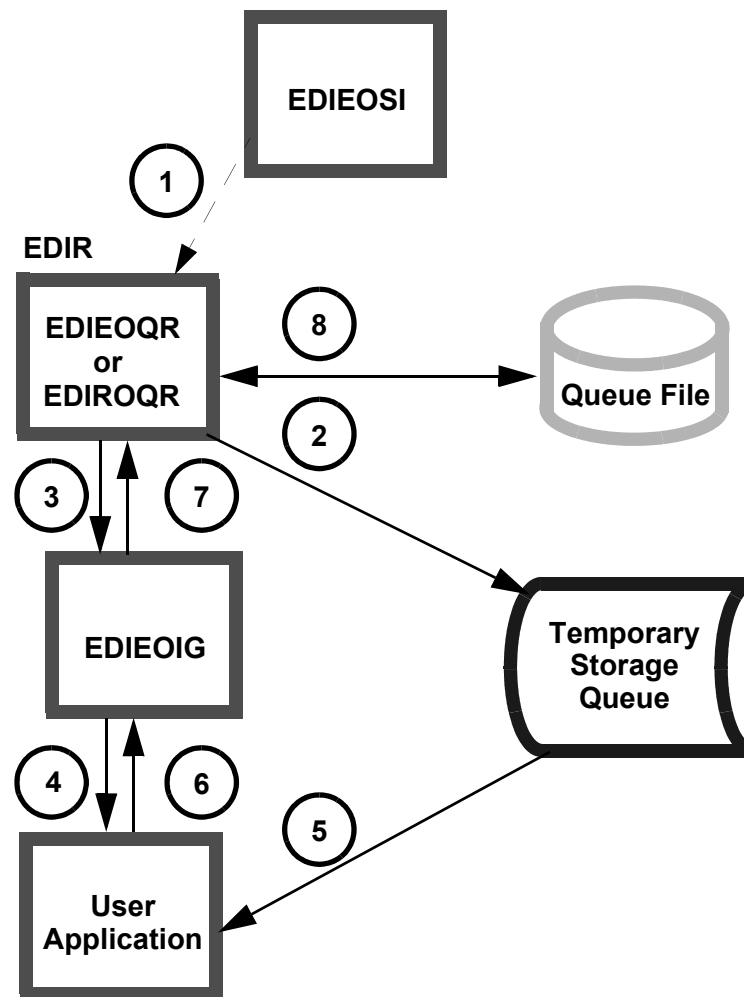

Figure 4.18 Overview of Online Input Gateway Operation

The following steps describe Online Input Gateway operation.

1. The Online Scanner/Initiator program (EDIEOSI) starts the transaction EDIR which runs the Online Queue Read program (EDIEOQR).

Note: EDIEOQR transfers to EDIROQR when an odd numbered queue file is being processed. Conversely if EDIROQR encounters an even numbered queue file it will transfer to EDIEOQR.
2. The Online Queue Read program (EDIEOQR) reads the queue file and writes the data to a TSQ.
3. After all the data within a given document group is read, the program links to the Online Input Gateway (EDIEOIG).

4. The Online Input Gateway formats the communication link area and links to the user application specified on the Queue Options Maintenance screen.
5. The user application reads the TSQ and performs all required processing.
6. The user application deletes the TSQ and returns to the Online Input Gateway. Any error conditions are passed back in the Error Level and Status Code fields.
7. The Online Input Gateway checks the error level and status code and returns to the Online Queue Read program.
8. The Online Queue Read program updates the queue file pointers and then determines whether or not another document group needs to process. If another document group needs to process, the program starts the entire procedure again.

Note: CICS limits the number of records that can be written to a TSQ to no more than 32,767 records. If a queue file has more than 32,767 records, there are two methods that Control uses to pass the data.

The first method performs multiple links to the user program, each time passing 32,767 records in a TSQ until all the data is processed. The Begin Document Indicator and the End Document Indicator inform the user program that it is receiving one group of data at a time. (i.e. “Begin = Y and End = N” implies first group of documents; “Begin = N and End = N” implies subsequent groups; “Begin = N and End = Y” implies the last group.)

The second method involves the use of Chained TSQs. The TSQ Store Switch must be set to C on the Queue Maintenance screen. The user program then receives the name of the first TSQ, which has an eye-catcher (###TSQ= in columns 1-7) in the last record. This identifies the next TSQ containing data. All subsequent TSQs have an eye-catcher pointing to the next TSQ. The last TSQ does not have an eye-catcher. The user application is responsible for deleting all these TSQs.

Control Structure

The procedures and techniques used to communicate between the Gateway and the user application are known as the *control structure*. The user application must be written to receive a communication area that tells it where to read the data and how to return control to the Gateway. The user application must set the status code and error level, and be prepared for multiple executions.

Examples of the control structure process follow:

Example A.

The document group contains less than 32,767 records.

1. The Gateway creates a TSQ containing the records for the document group.
2. The Gateway program initializes the parameter list to the user application, then links to the user application. The document group indicators are set by the Gateway to indicate both the beginning and the end of the document group (i.e. Begin Document Ind. = 'Y', and End Document Ind. = 'Y').
3. The user application processes the document group, then deletes the TSQ.
4. The user application returns to the Gateway. The Gateway examines the status code to determine whether or not the document group was accepted by the user application, and examines the error level to determine whether or not any errors were encountered. Any error message provided by the user application is written to the Online Log file.

Example B.

The document group contains more than 32,767 records.

1. The Gateway creates a TSQ containing the first part of the document group.
2. The Gateway initializes the parameter list to the user application and then links to the user application. The document group indicators are set by the Gateway to indicate the beginning, but not the end, of the document group (i.e. Begin Document Ind. = 'Y', and End Document Ind. = 'N').
3. The user application processes the document group, then deletes the TSQ.
4. The user application returns to the Gateway. The Gateway examines the status code to determine whether or not the document group was accepted by the user application, and examines the error level to determine whether or not any errors were encountered. Any error message provided by the user application is written to the Online Log file.
5. The Gateway creates a TSQ containing the next part of the document group, and links to the user application, indicating that the document group neither begins nor ends on this link (i.e. Begin Document Ind. = 'N', and End Document Ind. = 'N'). The user application processes the portion of the document group and deletes the TSQ. Upon return, the Gateway checks the status code and error level as before.

This process repeats until the last part of the document group is processed. On the last link, the Gateway indicates that the document group ends (i.e. Begin Document Ind. = 'N', and End Document Ind. = 'Y').

Parameters

The parameters for the Online Input Gateway are described below. The source for this layout is located in the member EDIEIGCA in the library GENTRAN.V6X4.CTL.UTILITY.SOURCE.

Position	Length	Format	Field Name	Value
Control Values Passed to Application from Gateway				
01 – 03	03	AN	System Image ID	
04 – 06	03	ZD	Queue File Number	
07 – 14	08	AN	Name of TS Queue	
15 – 15	01	AN	Begin Document Ind.	Y or N
16 – 16	01	AN	End Document Ind.	Y or N
Control Values Returned to Gateway from Application				
17 – 18	02	AN	Error Level	
19 – 20	02	AN	Status Code	
21 – 120	100	AN	Return Message	

Field Descriptions (Passed Fields)

System Image ID:

A 3-position alphanumeric field identifying the Gentran:Control system image used.

Queue File Number:

A 3-position numeric field indicating the queue file number. The document group was obtained from this queue file.

Name of TS Queue:

A 1- to 8-position alphanumeric field containing the name of the TSQ to be processed by the user application.

Begin Document Ind.:

A 1-position alphanumeric field indicating whether or not the TSQ contains the beginning of this document group. Valid values are:

Y	=	TSQ contains the beginning of this document group.
N	=	TSQ does not contain the beginning of this document group.

End Document Ind.:

A 1-position alphanumeric field indicating whether or not the TSQ contains the end of this document group. Valid values are:

Y	=	Yes; the TSQ contains the end of this document group.
N	=	No; the TSQ does not contain the end of this document group.

Field Descriptions (Returned Fields)**Error Level:**

A 2-position numeric field indicating the highest error level that occurred in the user application program or any of its subfunctions. A value of "00" indicates that no errors occurred.

Any value other than 00 causes an error message and results in the queue file becoming disabled. If you pass a message in the Return message area, the message is displayed on the Online Log.

Status Code:

A 2-position numeric field indicating the success or failure of the requested function. Valid values are:

00	=	Document group accepted by application interface; the document group is committed by the Online Input Gateway if this is the end of this document group.
04	=	Document group could not be processed by the application. This implies that the program cannot function properly at the present time. The Queue read program attempts to process the document group on the next process cycle. The queue file will not be disabled.
16	=	Document group rejected by application interface; the Online Input Gateway terminates and no further documents are passed. The next time the Online Scanner/Initiator starts, an error message is written and the queue file is disabled.

Note: If you return an error level of 00 and a status code of 04, the Online Scanner Initiator issues a stall message, but keeps the queue file enabled. The Stall Limit field on the Queue Options Maintenance screen is then used to limit the number of stalls that occur before the queue file is disabled. Entering 99 in the Stall Limit field indicates that an unlimited number of stalls can occur (i.e., the Queue is never disabled, but many stall messages could be created).

Return Message:

A 1- to 100-position alphanumeric, textual message describing any error encountered by the user application or its subfunctions. If a non-zero error level is returned, the Online Input Gateway records this message on the Online Log file.

Interface Design Considerations

Familiarize yourself with the following information before designing interface programs to the Online Input Gateway.

Inbound Application Interface Considerations

- Inbound applications are linked to from the Online Input Gateway to receive application data from the Gentran:Basic system.
- The TSQ contains application record images with trailing spaces truncated (e.g., the record length is variable). Each record is 1 to 8000 bytes in length.
- A document group will contain all records for the application.
- If a document group exceeds 32,767 records, then multiple links to the user application are required to complete the document group. The Gateway holds the queue file through the series of links until the end of the document group has been reached. If the user application finds that it cannot complete the document group, then it must set the error level value to “16,” and optionally can indicate the reason in the Return Message and Status Code fields.
- Access to an individual queue file is serialized. In particularly busy systems, the user application should be designed to operate asynchronously from the rest of the application so as not to cause the rest of the application to serialize processing.
- The application (when in control) may terminate or return an error level of “16” without affecting the queue file (e.g., the queue file remains as it was before the link to the application). Any document group data passed to the user application remains on the queue file in its entirety, and the queue file is freed by CICS during task termination. The next time the Online Scanner/Initiator starts, an error message is sent, and the Queue is disabled.

Note: To avoid the error message and queue file disable, enter a return of 00 in the error level and 04 in the Status Code.

Outbound Communication Interfaces

- The considerations for inbound applications described in the previous section also apply to outbound applications, with the following difference: the TSQ contains record images of EDI data. The record images may be variable in length from 1 to 8000 bytes.

Exception Exit**EDIEXIT1**

The Exception Exit program (EDIEXIT1) is a sample program that is used to process any document groups that have errors. The Exception Exit is called by the Online Queue Read program (EDIEOQR or EDIROQR) whenever an error level greater than 04 is encountered.

Note: The Exception Exit program name must be entered in the Exception Pgm field on the Queue Options Maintenance screen.

The Exception Exit program can be used to bypass processing of any document groups that have errors. The Sample Exception Exit program (EDIEXIT1) is located in the Gentran:Control library GENTRAN.V6X4.CTL.UTILITY. SOURCE.

Operation

The Exception Exit program receives parameters from the Online Queue Read program (EDIEOQR EDIROQR) that identify the error and where the data is stored. Design your Exception Exit program to perform the functions required by your organization (e.g., notifying users of errors, storing the data, etc.).

Design the Exception Exit program so that it sets the return error level to 16 if it cannot process data properly. This value tells the Online Queue Read program to keep the data on the queue file. If EDIEXIT1 does not set the error level to 16, the Online Queue Read program updates the pointers, which removes the data from the queue file.

Control Structure

The control structure that Gentran:Control uses with the Exception Exit program, and by which the program returns to the Gateway, works in the following manner.

1. The Online Queue Read program (EDIEOQR or EDIROQR) links to the Exception Exit program specified on the Queue Options Maintenance screen whenever an error is encountered which would cause the queue file to disable (e.g., an error level greater than 04).
2. The Exception Exit program processes according to the data specified in the parameters.
3. The Exception Exit program returns to Gentran:Control.

Parameters

The parameters passed to the Exception Exit program follow:

Position	Length	Format	Field Name
Values Passed to Exit			
01 – 03	3	AN	Program Image
04 – 06	3	AN	System Image ID
07 – 09	3	ZD	Queue File Number
10 – 17	8	AN	Name of TSQ
18 – 19	2	AN	Error Level
20 – 21	2	AN	Status Code
22 – 121	100	AN	Error Message
122 – 123	2	AN	Error Source Indicator
Values Returned from Exit			
124 – 125	2	AN	Return Error Level
125 – 150	25	AN	Reserved for Future Use

Field Descriptions (Passed Fields)

Program Image ID:

A 3-position, alphanumeric field indicating the starting characters for all Gentran:Control program names. Program Image ID is set up during installation. The default is EDI.

System Image ID:

A 3-position alphanumeric field indicating the System Image ID. Valid values are:

XXX = Where XXX is any three alphanumeric characters (first character must be alphabetic).

EDI = This is the default value.

In the CICS environment, a three-character System Image ID identifies all files belonging to a particular system image. All file DDnames, CICS enqueue names, etc., are prefixed by this System Image ID.

Queue File Number:

A 3-position numeric field indicating the queue file number of the queue file for which the document group received an error while processing. Valid values are **001** to **999**.

Name of TS Queue:

A 1- to 8-position alphanumeric field indicating the name of the TSQ holding the document group in error.

Error Level:

A 2-position numeric field indicating the highest error level that occurred in the user application program or any of its subfunctions. A value of 00 indicates that no errors occurred.

Status Code:

A 2-position alphanumeric field indicating the failure of the document group. Valid values are:

08	=	Severe error encountered.
16	=	Fatal error encountered.

Error Message:

A 1- to 100-position alphanumeric field containing a textual description of the error that caused this document group to be sent to the Exception Exit.

Error Source Ind.:

A 2-position alphabetic field indicating the program that generated or intercepted the error. Valid values are:

QB	=	The Queue Read program encountered the error.
OE	=	The Outbound Editor generated the error (Gentran:Realtime only).
OM	=	The Outbound Mapper generated the error (Gentran:Realtime only).
IE	=	The Inbound Editor generated the error (Gentran:Realtime only).
IM	=	The Inbound Mapper generated the error (Gentran:Realtime only).

Field Descriptions (Returned Field)**Return Error Level:**

A 2-position numeric field indicating the highest error level that occurred in the Exception Exit program. A value of 00 indicates that no errors have occurred.

Interface Design Considerations

Familiarize yourself with the following information before designing interface programs to the Exception Exit program.

- Any files that your Exception Exit program writes to should have the “logging” option turned off. Gentran:Control performs a ROLLBACK function after it has completed the Exception Exit program.

Note: The ROLLBACK removes data from any file on which the “logging” option is active.

- Design your Exception Exit program to store the document group in a file or have a method of recreating the document group from the data’s original source (after execution of the Exception Exit program, data is removed from the queue file).

Online Error User Exit

EDIEXIT2

The Online Error User Exit program (EDIEXIT2) is a sample application interface you can use to pass error notification messages to user systems. The Sample Error Exit program (EDIEXIT2) is located in the Gentran:Control library: GENTRAN.V6X4.CTL.UTILITY.SOURCE.

The Online Error User Exit is called by the Online Message Handler program (EDIEOMH or EDIROMH) whenever an error level greater than 04 is encountered. The primary difference between EDIEXIT1 and EDIEXIT2 is that the Online Error User Exit (EDIEXIT2) receives *all* messages from *all* programs within the Gentran:Control system, but it does not receive data. The Exception Exit program (EDIEXIT1) receives only those messages generated by the Online Queue Read program, and it also receives the data that is responsible for the error.

Operation

The Online Error User Exit program name must be entered in the Error User Exit Pgm field on the Queue Options Maintenance screen or System Options Maintenance screen. Any Exit program name entered on Queue Options Maintenance screen overrides any program name you enter on the Systems Options Maintenance screen, if both are present. The Online Error User Exit data specified on the screen is passed to the Exit in order to instruct the Exit program to perform different processes.

Any program within Gentran:Control that generates a message calls the Online Message Handler program (EDIEOMH or EDIROMH). This program checks the error level for the message and links to the Online Error User Exit if the program name is specified. This Exit should be designed to perform the functions your organization requires (e.g., notify users of the error, send operator messages, etc.)

Control Structure

The control structure that Gentran:Control uses with the Online Error User Exit program, and that the program returns to Gentran:Control, works in the following manner:

1. A Gentran:Control program encounters an error, formats a communication area, and links to the Online Message Handler program (EDIEOMH or EDIROMH).
2. The Message Handler program reads the Message file (EDIERRC) and formats the message, writing it to the Online Log file (EDIOLF). The Message Handler then checks the queue file to determine whether an Error User Exit has been specified (depending on whether the queue file is being processed at the time the error occurs). If no Exit is found, the Message Handler checks the System Options Maintenance screen for an Error User Exit specification.
3. If an Online Error User Exit specification is found, the Message Handler links to the Online Error User Exit program.

4. The Online Error User Exit program performs the functions directed by your installation and returns to the Message Handler.

Note: If a given process or program generates multiple error messages, then the Online Error User Exit program is called multiple times. Design your exit program to handle this possibility, or make the system or person receiving the messages aware that multiple calls may occur.

Parameters

The following table describes parameters passed to the Online Error User Exit program.

Position	Length	Format	Field Name	Value
Values to User Exit				
01 – 05	5	ZD	Error Message Number	
06 – 25	20	AN	Error Exit Data	Data from screen
26 – 28	3	ZD	Queue File Number	
29 – 148	120	AN	Formatted Message	

The following example illustrates a layout of the formatted message.

```

0029-0148  120    AN    Formatted Message

Formatted Message is defined as:
0029-0031  3      AN    'EDI' - System Image
0032-0032  1      AN    \_
0033-0037  5      AN    Error Message
0038-0038  1      AN    \_
0039-0039  1      AN    Status Code
0040-0041  2      AN    Return Code
0042-0148  107   AN    Message Text
    
```

Field Descriptions**Error Message Number:**

A 5-position numeric field indicating the error number that was encountered, which resulted in the link to the Online Error User Exit program.

Error Exit Data:

A 20-position alphanumeric field containing data as specified in the Online Control file for this queue file.

Queue File Number:

A 3-position field indicating the queue file number of the queue file that was being processed when the error occurred.

Formatted Message:

A 120-position alphanumeric field containing the error message that was sent to the Log File that corresponds to the Error Message number above.

Online Batch Initiator

EDIEOBI

The Online Batch Initiator program initiates batch processing by submitting JCL to the Internal Reader.

Operation

The Online Batch Initiator program is started as a CICS task by either the Online Scanner/Initiator program (EDIEOSI) or the Online Output Gateway (EDIEOOG). The Online Batch Initiator retrieves its task data, serializes on the Internal Reader destination, and copies the JCL specified on the Online Control file to the Internal Reader. The Batch Initiator will check the Gentran:Control configuration record to determine if a user submit exit has been specified. If there is an exit present then the Batch Initiator will write the JCL to a tsq and then pass this to the user exit. This provides the capability of using different scheduling products to perform the actual submit and control of the batch output and processes. A sample exit (EDISUBXT) is included on the UTILITY.SOURCE library.

Inputs

The following table describes inputs for the Online Batch Initiator program.

DDname	Description
EDIRJCL	JCL file

Outputs

The following table describes outputs for the Online Batch Initiator program.

DDname	Description
EDIINT	Internal Reader DCT entry

Control Structure

The control structure that Gentran:Control uses with the Online Batch Initiator program requires that processing be started by the Online Scanner/Initiator (EDIEOSI).

Online Scanner/Initiator

EDIEOSI

The Online Scanner/Initiator program (EDIEOSI) determines when to initiate online and batch processing based on either data levels or time intervals, according to the criteria for these characteristics entered on the Queue Options Maintenance screen.

Operation

The Online Scanner/Initiator program initiates itself at regular time intervals (the time interval is determined by value entered in the Scan Interval field on the System Options Maintenance screen). You can start the Online Scanner/Initiator using either a Program List Table (PLT) entry, or by entering its TRANSID (“EDII”) from a terminal.

When the Online Scanner/Initiator runs the first time, it initializes the Gentran:Control online system. During this process, all enabled queue files are validated. If an error occurs during this process, the queue file is disabled and the Online Scanner/Initiator creates a task to initiate itself at the designated scan time.

On subsequent runs, the Online Scanner/Initiator determines that it has been re-initiated by itself (and does not re-initialize the system). EDIEOSI then determines whether or not any online or batch processing must be initiated based on the queue files' designated data trigger levels or time intervals. Separate online queue read and online batch initiator tasks are started for each queue file that requires processing. Before terminating, EDIEOSI creates a task for the next designated scan time.

If the Gentran:Control system is re-initialized by manually starting the Online Scanner/Initiator, any previously-created Online Scanner/Initiator tasks detect this re-initialization and terminate.

Inputs

The following table describes inputs for the Online Scanner/Initiator program.

DDname	Description
EDIOCF	Online Control File
EDICKP	Checkpoint File
EDIQ nnn	Queue Files (where nnn is the queue file number)

Outputs

The following table describes output for the Online Scanner/Initiator program.

DDname	Description
EDIOCF	Online Control file
EDIQ nnn	TSQ for each queue file (where nnn is the queue file number)

Control Structure

The control structure that Gentran:Control uses with the Online Scanner/Initiator program works in the following manner: the Online Scanner/Initiator restarts itself based on the scan interval established on the System Options Maintenance screen, but the program also can be restarted manually by entering **EDII** on a CICS terminal.

Automatic System Start-up

EDIEPLT

The Automatic System Start-up program (EDIEPLT) is used to start the Gentran:Control system during CICS initialization.

Operation

EDIEPLT is executed by the CICS Program List Table (PLTPI). The program initializes the Gentran:Control system by starting the Online Scanner transaction EDII.

Control Structure

The EDIEPLT program is provided in the UTILITY.SOURCE library. The program has a simple structure that involves issuing a CICS START command on the EDII transaction (program EDIEOSI) and passing a parameter that tells the system the starting method. This program must be customized if the system image is changed from EDI. Simply change the transaction being started from EDII to reflect the new system image.

Sample Online Application

EDIESOA

The Sample Online Application program (EDIESOA) demonstrates the Gentran:Control system and provides a coding sample.

Operation

The Sample Online Application program is called by the Online Input Gateway (EDIEOIG). EDIESOA copies data to a second TSQ and calls the Online Output Gateway (EDIEOOG). EDIESOA cannot operate as a standalone program.

Inputs

The following table describes input for the Sample Online Application program.

TSQ	Description
tsqname	TSQ passed from the Online Input Gateway

Outputs

The following table describes output for the Sample Online Application program.

TSQ	Description
tsqname	TSQ passed to the Online Output Gateway

Control Structure

The control structure that Gentran:Control uses with the Sample Online Application program works in the following manner: the value EDIEOSA must be entered in the Appl.Prog field on the Queue Options Maintenance screen.

Separator Gateway

EDIR100

Separator Gateway program (EDIR100) is the application interface to the Separator subsystem. User programs that want to pass data to the Separator Driver (EDIR930) link to the Separator Gateway. The Separator Gateway is also used as the application program on the Queue Options screen when the data in a queue file is to be passed to the Separator subsystem.

Operation

The user application writes its data to a TSQ (Temporary Storage Queue). It formats the linkage area (EDIEOGCA in the UTILITY.SOURCE library) with the System image, TSQ name, process number (600), and beginning, ending, and batch indicators. It then passes control to the Separator Gateway. Upon completion of processing, the gateway returns an error level, a status code, and an error message to the user program.

Inputs

The Linkage area is the only input. Its layout is:

```

05  LOOG-COMMAREA.
    10  LOOG-ENTRY-VALUES.
        15  LOOG-SYSIMAGE          PIC X(03).
        15  LOOG-QFNR              PIC 9(03).
        15  LOOG-TDQNAME           PIC X(08).
        15  LOOG-BEG-OF-DOCGROUP-IND PIC X(01).
            88 LOOG-BEG-OF-DOCGROUP-YES VALUE 'Y'.
        15  LOOG-END-OF-DOCGROUP-IND PIC X(01).
            88 LOOG-END-OF-DOCGROUP-YES VALUE 'Y'.
        15  LOOG-INIT-BATCH-IND     PIC X(01).
            88 LOOG-INIT-BATCH-YES   VALUE 'Y'.
    10  LOOG-RETURN-VALUES.
        15  LOOG-ERROR-LEVEL        PIC X(02).
        15  LOOG-STATUS-CODE        PIC X(02).
        15  LOOG-FORMATTED-ERROR-MSG PIC X(100).

```

Outputs

None.

Reports

None.

Control Card Options

Control is passed from a user program that uses the linkage area in the Queue file gateways. The source for this layout is located in the member EDIEOGCA in the UTILITY.SOURCE library.

Position	Length	Format	Field Name	Value
Control Values Passed to Gateway from Application				
01 – 03	3	AN	System Image ID	System Image setup during installation
04 – 06	3	ZD	Separator Option	600 for Separation processing
07 – 14	8	AN	Name of TS Queue	
15 – 15	1	AN	Begin Document Ind.	Y
16 – 16	1	AN	End Document Ind.	Y
17 – 17	1	AN	Batch Process Ind.	N
Control Values Returned to Application from Gateway				
18 – 19	2	AN	Error Level	
20 – 21	2	AN	Status Code	
22 – 121	100	AN	Error Message	

Separator Driver

EDIR930

The Separator Driver program processes inbound EDI data and separates it into individual interchanges for processing by the Interchange Priority Lookup and the Router programs. The program verifies the presence of headers and trailers and sends unrecognizable data and data with missing envelope information to a user program.

Operation

Data can be passed from a user application, from a queue file or from the Connect Inbound Interface. Data is passed to the Separator Gateway (EDIR100) by means of a TSQ. The Gateway does some checking of the passed parameters then passes control to the Separator Driver. The Separator Driver reads the TSQ and determines the beginnings and ends of interchanges, and writes them to individual TSQs. These TSQs then are passed to the individual Interchange Priority Lookup programs (EDIR931, EDIR932, and EDIR933), which evaluate the interchange and determine the priority and processing to be performed on this interchange. The Interchange Lookup programs then pass control back to the Driver, which creates a record in the Control TSQ. Optionally, the Separator can call the Monitor I/O program (EDIR940) to store header and optionally the data on the files EDIRMNH and EDIRMNS. After all data is processed, the Driver links to the Router program (EDIR945), which then starts the translation processes in the order of the priorities assigned.

Inputs

The following table describes inputs for the Separator Driver program.

DDname	Description
EDIRSEP	Separator Control file

TSQname	Description
<i>nnnnnnnn</i>	TSQ name passed in linkage
EDIXTSNS	Sequence numbering TSQ

Outputs

The following table describes outputs for the Separator Driver program.

TSQname	Description
EDIYSSSS	Multiple TSQs (one per interchange)
EDIKSSSS	Interchange Control TSQ

Reports

None.

Control Card Options

Control is passed from a user program which uses the same linkage area that is used by Control gateways. The layout of the linkage area is:

```
05  LOOG-COMMAREA.
    10  LOOG-ENTRY-VALUES.
        15  LOOG-SYSIMAGE          PIC X(03).
        15  LOOG-QFNR              PIC 9(03). VALUE 600.
        15  LOOG-TDQNAME          PIC X(08).
        15  LOOG-BEG-OF-DOCGROUP-IND  PIC X(01).
            88  LOOG-BEG-OF-DOCGROUP-YES  VALUE 'Y'.
        15  LOOG-END-OF-DOCGROUP-IND  PIC X(01).
            88  LOOG-END-OF-DOCGROUP-YES  VALUE 'Y'.
        15  LOOG-INIT-BATCH-IND     PIC X(01).
            88  LOOG-INIT-BATCH-YES      VALUE 'Y'.
    10  LOOG-RETURN-VALUES.
        15  LOOG-ERROR-LEVEL       PIC X(02).
        15  LOOG-STATUS-CODE       PIC X(02).
        15  LOOG-FORMATTED-ERROR-MSG  PIC X(100).
```

Note: This linkage should be passed to the Separator Gateway (EDIR100), which formats the data, then passes it to the Separator Driver (EDIR930).

X12 Interchange Priority Lookup

EDIR931

The X12 Interchange Priority Lookup program evaluates ASCX12 EDI data passed to it from the Separator Driver program (EDIR930) and determines the priority and the process that the data is to be assigned.

Operation

The Separator Driver program separates the interchanges into individual TSQs and then passes them to the Interchange Priority Lookup. The Driver also writes all the header envelopes to a separate TSQ. All X12 interchanges are sent to EDIR931. The Lookup program then uses information from the envelopes (ISA, GS, and ST) to look up the process to be performed. (Process in this context is the Priority and the specific Immediate Option, Queue Option or user program that will process the data.) The information then is passed back in the linkage area to the Separator Driver.

The information used from the envelopes is: Interchange Sender ID and Qualifier; Interchange Receiver ID and Qualifier; Interchange Test/Production Indicator; Group Functional ID; Group Version; Group Sender ID; Group Receiver ID; and Transaction ID. Key Usage Indicators on the Separator System Options Maintenance Screen (EDIM935) instruct the program as to which fields to use during the look for the process. All of these fields are used to construct keys to the Separator Control file and then to read the file and return the results of the first match.

See the “Separator Subsystem” section in Chapter 1 of this guide for more details on the system.

Inputs

The following tables describe inputs for the X12 Interchange Priority Lookup program.

DDname	Description
EDIRSEP	Separator Control file

TSQname	Description
EDIY _{SSSS}	TSQ name passed in linkage

Outputs

The following table describes outputs for the X12 Interchange Priority Lookup program.

TSQname	Description
EDIK _{SSSS}	Interchange Control TSQ

Reports

None.

EDIFACT Interchange Priority Lookup

EDIR932

The EDIFACT Interchange Priority Lookup program evaluates EDIFACT EDI data passed to it from the Separator (EDIR930) and determines the priority and the process that the data is to be assigned.

Operation

The Separator Driver program separates the interchanges into individual TSQs and then passes them to the Interchange Priority Lookup program. The Driver also writes all the header envelopes to a separate TSQ. All EDIFACT interchanges are sent to EDIR932. The Lookup program then uses information from the envelopes (UNA, UNB, UNG, and UNH) to look up the process to be performed. (Process in this context is the Priority and the specific Immediate Option, Queue Option, or user program that will process the data). The information then is passed back in the linkage area to the Separator Driver.

The information used from the envelopes is: Interchange Sender ID and Qualifier; Interchange Receiver ID and Qualifier; Interchange Test/Production Indicator; Group Functional ID; Group Version; Group Sender ID; Group Receiver ID; and Transaction ID. Key Usage Indicators on the Separator System Options Maintenance Screen (EDIM935) instruct the program as to which fields to use during the look for the process. All of these fields are used to construct keys to the Separator Control file and then to read the file and return the results of the first match.

See the “Separator Subsystem” section in Chapter 1 of this guide for more details on the system.

Inputs

The following tables describe inputs for the EDIFACT Interchange Priority Lookup program.

DDname	Description
EDIRSEP	Separator Control file

TSQname	Description
EDIY _{SSSS}	TSQ name passed in linkage

Outputs

The following table describes outputs for the EDIFACT Interchange Priority Lookup program.

TSQname	Description
EDIK _{SSSS}	Interchange Control TSQ

Reports

None.

TRADACOMS Interchange Priority Lookup

EDIR933

The TRADACOMS Interchange Priority Lookup program evaluates TRADACOMS EDI data passed to it from the Separator Driver program (EDIR930) and determines the priority and the process that the data is to be assigned.

Operation

The separator Driver program separates the interchanges into individual TSQs and then passes them to the Interchange Priority Lookup. The Driver also writes all the header envelopes to a separate TSQ. All TRADACOMS interchanges are sent to EDIR933. The Lookup program then uses information from the envelopes (SCH, STX, and MHD) to look up the process to be performed. (Process in this context is the Priority and the specific Immediate Option, Queue Option or user program that will process the data.) The information then is passed back in the linkage area to the Separator Driver.

The information used from the envelopes is: Interchange Sender ID and Qualifier; Interchange Receiver ID and Qualifier; Interchange Test/Production Indicator; Group Functional ID; Group Version; Group Sender ID; Group Receiver ID; and Transaction ID. Key Usage Indicators on the Separator System Options Maintenance screen (EDIM935) instruct the program as to which fields to use during the look for the process. All these fields are used to construct keys to the Separator Control file and then to read the file and return the results of the first match.

See the “Separator Subsystem” section in Chapter 1 of this guide for more details on the system.

Inputs

The following tables describe inputs for the TRADACOMS Interchange Priority Lookup program.

DDname	Description
EDIRSEP	Separator Control file

TSQname	Description
EDIY _{SSSS}	TSQ name passed in linkage

Outputs

The following table describes outputs for the TRADACOMS Interchange Priority Lookup program.

TSQname	Description
EDIK _{SSSS}	Interchange Control TSQ

Reports

None.

Monitor Input/Output

EDIR940

The Monitor I/O program is an optional program that stores control information (on the EDIRMNH file) and the data (on the EDIRMNS file) after Separator/Router/Splitter operations have separated the data into interchanges or transactions. This information is used primarily for tracking the Separation process and for restarting the individual processes if necessary.

Operation

The Monitor I/O program is called by the Separator Driver program (EDIR930) and the Router program (EDIR945). The Separator program calls it to add and update records on the two monitor files after the batch has been separated into interchanges and the priority and process have been determined by the lookup programs. The Router program updates the Monitor Header file (EDIRMNH) after the process is completed for the interchange.

The operations are controlled by the switches set on the Separator System Options Maintenance screen (EDIM935). The input/output to both files can be disabled, or only the storage of data on EDIRMNS can be disabled from the Monitor Indicator/Store Switches on the screen.

Inputs

The following tables describe inputs for the Monitor I/O program.

DDname	Description
EDIRMNH	Monitor Header file
EDIRMNS	Monitor Store file

TSQname	Description
EDIY _{SSSS}	TSQ name passed in linkage
EDIK _{SSSS}	Control TSQ passed in linkage

Outputs

The following table describes outputs for the Monitor I/O program.

DDname	Description
EDIRMNH	Monitor Header file
EDIRMNS	Monitor Store file

Reports

None.

Router

EDIR945

The Router program is the driver for the processing of the separated interchanges that have been created by the Separator Driver, or of the splits performed by the Inbound or Outbound Splitter programs.

Operation

A control TSQ is passed to the Router from the Separator Driver. This control TSQ contains information about where data can be found and the processing characteristics for that data (e.g., process option, priority). The Router performs the processes in the order of the priorities. If the process involves a Realtime Immediate Option, the Router starts transaction EDIA (Realtime Asynchronous Gateway task) and passes it the information needed in its link area. A time delay is set on all priorities that are greater than 1. Each priority has a 10 second time delay over the previous priority (e.g., priority 2 gets a 10 second delay, priority 7 gets a 60 second delay, etc.). If the process is to write to a queue file, the process is performed immediately (with no time delay). If the process is to send the data to a user program, that also is done immediately. A maximum start count and delay time (entered on the Separator Systems Options Maintenance Screen) will cause an additional delay when the maximum start count is reached.

Inputs

The inputs for the Router program follow:

TSQname	Description
EDIY _{SSSS}	TSQ name passed in linkage
EDIK _{SSSS}	Control TSQ passed in linkage

Outputs

None.

Reports

None.

Application Log Interface

EDIR999

Purpose

This facility allows user-application programs or user-communications programs to log information into Gentran:Control/Realtime.

Operation

The Application Log Interface (EDIR999) writes messages to the Online Log file (EDIOLF). The Online Log then becomes a window into the entire Gentran:Control/Realtime process containing information about the Application processing the Gateways, the Gentran:Control/Realtime Translation, and Communications processing.

File Access

File Description	DDname	File Access
Online Log File	EDIOLF	Read and update.

Control Structure

The method that a user online program may use the Application Log Interface is described here.

- A Copybook (EDIRLOG) is required in the working storage of the user application program.
- User application must supply the system image ID, fill in the error severity code the error level code, and text of the message that will be on the Online Log file. The error severity, error level, and message text fields are user-supplied and convey the importance of this error. The information provided should indicate the error's importance with a clear message of the problem.
- The User Application LINKs to the Application Log Interface (EDIR999) when it wants to write a message to the Online Log File.
- The Application Log Interface writes the message to the Online Log File.
- The Application Log Interface then RETURNs to the User Application and supplies a return error level and error message text if an error was detected while writing to the Online Log file.

Parameters

The parameters passed to the Application Log Interface are described below.

Values Passed to Application Log Interface

Record Position	Length	Format	Field Name
0001 – 0002	2	BIN	Commarea Length
0003 – 0005	3	AN	System Image
0006 – 0006	1	AN	Error Severity
0007 – 0008	2	AN	Error Level
0009 – 0098	90	AN	Message Text

Values Returned from Application

Record Position	Length	Format	Field Name
0099 – 0100	2	AN	Return Error Level
0101 – 0130	30	AN	Return Error Text

Field Descriptions

Values Passed to Application Log Interface

Commarea Length

A 2-position binary (COMP) field for entering the length of the CICS communications area to be passed to the Application Log Interface. Enter a value of 130 (hex value:82).

System Image

A 3-position alphanumeric field for entering the System Image ID. Valid values are any three alphanumeric characters (first character must be alphabetic).

Enter the value EDI or your System Image if it is different than EDI. This value is required.

In the CICS environment, a 3-character System Image ID is used to identify all files belonging to a particular “system image”. All file DD names, CICS enqueue names, and so on, are prefixed by this 3-character System Image ID.

Error Severity

A 1-position alphabetic field for entering the error severity code. Valid values are:

I	=	Informational Message
W	=	Warning
E	=	Error in data
S	=	Severe error, processing ends
F	=	Fatal error, processing ends

The Application Log Interface places the value entered on the Online Log file record to indicate the severity for the action inferred. The error severity code will be listed on the Online Log display to identify various actions within the system by priority.

If a value is not entered, the system will default to the value I.

Note: Descriptions for the Error Severity values are generic in nature. These are “user-defined” values, however, it is suggested that you follow these guidelines when defining your Error Severity codes.

Error Level

A 2-position numeric field for enter the code that indicates the highest error level that occurred. Value values are:

00	=	Information only (successful completion of task)
04	=	Warning indicator (no action required)
08	=	Warning indicator (some action may be required)
12	=	Severe error indicator (with a normal termination)
16	=	Fatal error indicator (with a normal termination)

The Application Log Interface places the value entered on the Online Log file record to indicate the level for the action inferred. The error level code will be listed on the Online Log display to identify various actions within the system by priority.

If a value is not entered, the system will default to **00**.

Note: Descriptions for the Error Level values are generic in nature. These are “user-defined” values, however, it is suggested that you follow these guidelines when defining your Error Level Codes Message Text.

Message Text

A 90-position alphanumeric field used to enter the message text on the Online Log file. The message is user-defined text information and is listed on the Online Log display.

Values Returned from Application Log Interface

Return Error Level

A 2-position numeric field displaying the return error level. The Application Log Interface will place a 00 in this field if the write to the Online Log file was successful. Any value greater than 00 indicates that the Online Log file has not been updated.

Return Error Text

A 30-position alphanumeric field displaying the return error text. If an error has occurred while writing to the Online Log file the Application Log Interface returns a description of the error.

Interface Design Considerations

Considerations when designing interfaces to the Application Log Interface are provided below.

- The system image should have the value for the system you defined. The error severity and level, and message text must be setup.
- No special action is taken by the system just because you write a severe error to the log.
- Check the return error level and error text before continuing. If a value other than 00 is returned, a problem with the Online Log file has occurred and should be attended to based upon the return error message text indicated.

Note: The sample programs EDIRXIT1 and EDIRXIT2 have examples of linking to the Application Log Interface.

File Descriptions

Overview

This chapter contains the following topics related to Gentran:Control files.

Topic	Page	
Checkpoint File.....EDICKP	5-2	
Online Control File.....EDIOCF	5-4	
Queue Files.....EDIQnnn	5-6	
Monitor Header File	EDIRMNH	5-8
Monitor Store File	EDIRMNS	5-9

Checkpoint File

EDICKP

Description

The Checkpoint file is a VSAM RRDS (relative record data set) that detects system interruptions and communicates system status information between the various components of Gentran:Control and Gentran:Basic.

The file holds an individual record for each Queue file created for Gentran:Control processing. These records hold pointer values that must match the values of pointers that are on the first two records of the Queue files. Use only Gentran:Control utilities to update the Checkpoint file to guarantee that the pointer values match.

Activity

The Checkpoint file's initial allocation is the maximum size to which it can grow. The first time EDIEQMT (Queue File Maintenance) is run, all the records needed for processing the Checkpoint file are created. Subsequent runs of EDIEQMT update the appropriate record in the Checkpoint file. In addition, all programs that read or write a Queue file update the Checkpoint file. In all cases, only two records are read and one is rewritten.

Frequency of activity is dependent upon the number of batch processes that are being run to read or write the Queue files.

Program References

The Checkpoint file is accessed by all Gentran:Control batch programs, as well as the following Gentran:Control online programs:

Program	Purpose
Online Scanner/Initiator (EDIEOSI)	Reads the Checkpoint file during each scan to obtain current Queue file information.
Online Queue Write (EDIEOQW or EDIROQW)	Reads the Checkpoint file.
Online Queue Debug Detail (EDIX306)	Reads the Checkpoint file and displays the values of the internal pointers.

Disk Space Requirements

The initial definition of 30 tracks for the Checkpoint file is sufficient, because the Checkpoint file does not grow any larger after it is created.

Note: All disk space requirements in this chapter are expressed in 3380s-type tracks.

Data Set Recovery

Because the records on the Checkpoint file hold pointer values that must match the values of the pointers that are on the first two records of the Queue files, if these pointers ever become corrupted then the Queue file delivers inconsistent results.

If only one Queue file is experiencing problems, you can recover data sets by performing a delete/define on the Queue file, then running EDIEQMT to redefine the Queue file. Any data on the Queue file is lost, but all other Queue files are unaffected.

If the entire Checkpoint file is corrupted, then you can recreate it by performing a delete/define on the Checkpoint file and all Queue files, and rerunning the EDIEQMT program for each Queue file. If you complete this re-creation, however, *all* data on the Queue files is lost. Attempt to unload all Queue files before performing the delete/define. To unload the Queue files, disable the Gentran:Control system, then use the batch read program (EDIRQRD) to read all data to sequential files.

Note: Maintaining nightly backups of the Checkpoint file does not provide a recoverable data set, because the pointers will not match the current values on the Queue files. Backups would have to be kept of each Queue file and the Checkpoint file after each program that reads or writes a Queue file.

VSAM Data Set Definition

The JCL to define and load the Checkpoint file is located in the JCL library in member DEFCKP.

```
DEFINE CLUSTER (NAME (GENTRAN.V6X4.CTL.VSAM.EDICKP) -
VOLUME (XXXXXX) -
TRACKS (30) -
NUMBERED -
RECORDSIZE (200 200) -
SHR (4 3)) -
DATA (NAME (GENTRAN.V6X4.CTL.VSAM.EDICKP.DATA) -
CISZ (2048))
```

Online Control File

EDIOCF

Description

The Online Control file is a VSAM Key Sequence Data Set containing the parameter information that is used by the CICS portion of Gentran:Control. All data entered on the maintenance screens is stored on this file.

The Online Control file contains individual records for each Queue file option and system option. During CICS startup, all the options are written to TSQs. After startup, the majority of the system uses these TSQs rather than reading the EDIOCF file.

Activity

The Online Control file has a low volume of update and add activity, but the volume of read activity depends upon processing frequency and volume. For example, initial setup of the Gentran:Control system may involve moderate update/add activity while the Queue files are being created, but once the system is configured and running, the Online Control file should experience few, if any, updates and adds.

Program References

The Online Control file is accessed by the following programs:

Program	Purpose
Online Scanner/Initiator (EDIEOSI)	Reads the Online Control file during initialization and creates an in-memory copy of the Control file.
Extended Queue Options Maintenance	Updates the Online Control file.
Queue Directory	Reads the Online Control file.
Queue Options Maintenance	Updates the Online Control file.
System Options Maintenance	Updates the Online Control file.
Queue Options Debug Detail	Reads the Online Control file.
Queue Options Data Display	Reads the Online Control file.

Data Set Recovery

The Online Control file may be re-loaded from the Gentran:Control tape or recreated from a recent backup. If you use the tape or if the backup is not recent, you must use the Gentran:Control maintenance functions to re-enter your configuration information.

The recommended method of ensuring data set recovery is:

- Create a backup of the Online Control file after the system has been configured for production
- Create new backups on a regular basis.

Disk Space Requirements

This file contains under 1000 records; one record for each Queue file, plus one record for system information.

Note: All disk space requirements in this chapter are expressed in 3380s-type tracks.

VSAM Data Set Information

The JCL to define and load the Online Control file is located in the JCL library in member DEFCTL.

```

DEFINE CLUSTER (NAME (GENTRAN.V6X4.CTL.VSAM.EDIOCF) -
VOLUME (XXXXXX) -
RECORDS(10 10) -
FREESPACE(10 10) -
KEYS(3 0) -
RECORDSIZE(091 450) -
NOREUSE -
SHR (2 3) ) -
DATA (NAME (GENTRAN.V6X4.CTL.VSAM.EDIOCF.DATA) -
CISZ (4096) ) -
INDEX (NAME (GENTRAN.V6X4.CTL.VSAM.EDIOCF.INDEX

```

Queue Files

EDIQnnn

Description

The Queue files are VSAM RRDS that pass transaction data between the CICS and batch portions of Gentran:Control. The files process in a first-in, first-out, wrap-around fashion. Only access Queue files using Gentran:Control batch utility programs and CICS interfaces.

Queue files must be defined with no secondary allocations and be initialized by the Queue File Maintenance program (EDIEQMT) before they can be used. The initialization process consists of formatting the first two records to hold pointers and counts and formatting all the remaining records with null values.

During processing, the pointers on the first two records are adjusted to reflect where the data is located on the other records. The data is stored in blocks of approximately 4,050 bytes. Each logical record is prefixed by its length. Control information at the front of each record describes when and how the data was written and whether logical records are split between physical records.

See the section “System Operation“ in Chapter 1 of this guide for more information about Queue file processing.

Activity

Read and update activity is high; the Queue files do not have records added when activity occurs.

Program References

The Queue files are accessed by the following programs:

Program	Purpose
CICS	
Online Queue Read	Reads record images from the Queue file.
Online Queue Write	Updates records (writes new record images).
Online Batch Initiator	Reads queue status information.
Online Queue Directory	Reads the Queue files.
Online Queue Data Display	Reads the Queue file.
Online Queue Debug Display	Reads the Queue file.
Batch	
Multi-Queue Read	Reads record images.
Multi-Queue Write	Updates records (writes new record images).
Remote Single-Queue Read	Reads record images.
Remote Single-Queue Write	Updates records (writes new record images).
Queue File Maintenance	Writes records to format data set.

Data Set Recovery

Queue files must be recreated by defining the data set and using the Queue File Maintenance program (EDIEQMT) to initialize the data set.

Note: Data in the Queue file is lost in the recreation procedure.

Disk Space Requirements

The space requirement for an individual Queue file must be large enough to hold the largest volume of transaction data that you expect to be passed through the Queue file.

Record images are stored on the Queue file in a blocked format (e.g., multiple variable length record images per fixed-length Queue file record). Approximately 4,050 bytes of record image data can be stored on a Queue file record.

Note: All disk space requirements in this chapter are expressed in 3380s-type tracks.

The following example demonstrates a formula for determining Queue file size.

Example:

The Queue file is used for outbound application data. The largest number of documents expected between Gentran:Basic processing cycles is 100 transactions. Each transaction consists of 200 application records with an average record length of 250 bytes.

$$\begin{aligned} \# \text{ records} &= (100 \text{ transactions} \times 200 \text{ records} \times 250 \text{ bytes}) / 4,050 \text{ bytes} \\ &= 1234 \text{ records.} \end{aligned}$$

In this case, the value “1234” is the minimum sufficient size. Make the file even larger to avoid processing delays (e.g., “3000” in the information below).

VSAM Data Set Information

The JCL to define and load the Queue files is located in the JCL library in member EXECQMT.

```
DEFINE CLUSTER (NAME (GENTRAN.V6X4.CTL.VSAM.EDIQ???) -
VOLUME (XXXXXX) -
RECORDS (3000) -
NUMBERED -
RECORDSIZE (4088 4088) -
SHR (4 3) )
DATA (NAME (GENTRAN.V6X4.CTL.VSAM.EDIQ???.DATA) -
CISZ (4096))
```

Note: The Queue files must not have a secondary allocation. SHR(4 3) is used to force immediate disk write.

Monitor Header File

EDIRMNH

Description

This file stores the header information about the data that has been processed during Separator Driver program (EDIR930) processing. When monitoring is enabled (from screen EDIR935, the Separator instructs the Monitor I/O program (EDIR940) to store tracking information about the interchanges that have been separated. The Gentran:Realtime Splitter programs (EDIR015 and EDIR016) also instruct the Monitor I/O program to store information about split files.

Activity

This file can have heavy activity if many interchanges are being processed through the Separator.

Program References

The Monitor Header file is accessed by the following programs:

Program	Purpose
Monitor I/O (EDIR940)	Writes, reads, updates, and deletes the Header record.
Separator Monitor Directory (EDIR938)	Reads the Header file.

Disk Space Requirements

One record is generated for each interchange processed through the Separator and for each split in the Splitter program. The file should be large enough to handle two days worth of data.

Note: Each split can be at a transaction or at an interchange level.

Data Set Recovery

The file should be redefined, since it is only a temporary file and the data is written and deleted within a 24-hour time period.

VSAM Data Set Information

```

DEFINE CLUSTER (NAME (GENTRAN.V6X4.CTL.VSAM.EDIRMNH) -
VOLUME (XXXXXX) -
TRACKS (25 22) -
FREESPACE (10 10) -
KEYS (23 0) -
RECORDSIZE (220 220) -
SHR (2 3) -
DATA (NAME (GENTRAN.V6X4.CTL.VSAM.EDIRMNH.DATA) -
CISZ (4096) ) -
INDEX (NAME (GENTRAN.V6X4.CTL.VSAM.EDIRMNH.INDEX) )

```

Monitor Store File**EDIRMNS****Description**

The file stores the data that has been processed through the Separator Driver program (EDIR930). During Separator processing, as each interchange is separated, it is stored on this file. In addition, the Gentran:Realtime Splitter programs (EDIR015 and EDIR016) store the split data on this file.

Activity

Activity can be very heavy depending upon how much data is processed through the Separator, and whether the Store Switch is enabled (located on the Separator System Options Maintenance screen (EDIM935)).

Program References

The Monitor Store file is accessed by the following programs:

Program	Purpose
Monitor I/O (EDIR940)	Reads, writes, and deletes the data.
Separator Monitor Directory (EDIR938)	Reads the Header file.

Disk Space Requirements

Space is dependent upon the number of separate interchanges processed in one day, and the number of splits being performed. The file should be large enough to handle two days of data.

Data Set Recovery

The file should be redefined, since it is only a temporary file and the data is written and deleted within a 24-hour time period.

VSAM Data Set Information

```

DEFINE CLUSTER (NAME (GENTRAN.V6X4.CTL.VSAM.EDIRMNS) -
VOLUME (XXXXXX) -
TRACKS (55 20) -
FREESPACE (10 10) -
KEYS (26 0) -
RECORDSIZE (106 4122) -
SHR (2 3) -
DATA (NAME (GENTRAN.V6X4.CTL.VSAM.EDIRMNS.DATA) -
CISZ (4096) -
INDEX (NAME (GENTRAN.V6X4.CTL.VSAM.EDIRMNS.INDEX) )

```

JCL Submission and User Security

Overview

This chapter describes features that enable you to control the submission of JCL from the CICS system.

This chapter contains the following topics:

Topic	Page
Configuring JCL Submission and User Security	6-2
Introduction	6-2
Features	6-2
Batch Submit Exit and Security ID Configuration	6-3
User ID (Security).....	6-3
Batch Submit Exit	6-4

Configuring JCL Submission and User Security

Introduction

Under standard run parameters, Gentran:Control submits many batch jobs through the Internal Reader. The jobs submitted most often involve reading queue files and processing the data. Gentran:Control enables you to control the submission of the JCL and provide parameters to the JCL, including providing a different job card.

Features

The features described in this section enable you to control the submission of JCL from the CICS system.

Batch Submit Exit

The Batch Submit Exit enables you to have a customer program perform the submission of JCL. This allows the customer to bypass using the Internal Reader by using a CICS interface to a scheduler package, or to provide capabilities to track and control any jobs submitted.

User ID for Background Tasks

This feature enables you to assign a user ID to the EDII transaction, and therefore have it used by the JCL Submit transaction (EDIB), the Queue Read transaction (EDIR), and any other transactions started by EDII.

By using the user ID assigned to the EDII transaction, you can set security levels for that ID without having to give access to all individuals who might start the EDII transaction.

Batch Submit Exit and Security ID Configuration

You can configure the Batch Submit exit and security ID using the Configuration Maintenance screen, illustrated below.

```

EDIM231 _____ CONFIGURATION MAINTENANCE          XXX      12/01/2005
                                                    12:00:00

GENTRAN:Control Options - Record Type E Panel 1 of 1

Control System Identifier.....: GENTRAN:CO
                               NTROL_6.3_
Syncpoint Rollback Switch.....: 0 _____ 0=Enable 1=Disable
User ID for Background tasks...: _____
Batch Submit Exit.....: _____

Last Update Date: 00/00/00      Time: 00:00:00      User: SCI

Enter PF1=Help          PF3=Exit PF4=Dir          PF6=Nxt Cnfg
                        PF10=Updt
  
```

- A The **User ID for Background tasks** and **Batch Submit Exit** are optional fields on the Gentrans:Control Configuration record. The system uses the User ID for all background tasks started from the Scanner Initiator (transaction EDII/program EDIEOSI). The Batch Submit exit is used when the Online Batch Initiator program (EDIEOBI/transaction EDIB) runs. A sample program EDISUBXT is in the UTILITY.SOURCE library.

User ID (Security)

This section differentiates between two types of user IDs: the Gentrans user ID and a CICS user ID.

The Gentrans user ID is the signon ID you enter in the User ID field on the Gentrans signon screen (EDIM000) to access the Gentrans screens. The CICS user ID provides access to the CICS system. These IDs can be identical for a given user.

The CICS User ID

The user ID entered on the Configuration record will be a CICS user ID that is to be used by the EDII transaction. It must have full access authority to the Gentrans files and have authority to write to the Internal Reader.

When the EDII transaction starts, it checks for a CICS user ID, and restarts itself with that ID. EDII can be started many different ways -- by the PLTPI, by batch JCL, by online entry from a Gentran screen, by native CICS entry, or by an online program. Each of these can have different authority levels depending upon the individual or program initiating the action. The CICS user ID feature provides a method to control the access from this transaction without opening access to many different users. Any transaction that EDII starts after that will have this user ID assigned to it.

Batch Submit Exit

The EDIB transaction uses the Batch Submit exit program instead of the Internal Reader when it submits the JCL. A communication area is passed to the user program, which provides the system image, the program image, the JCLname to be submitted, the jobname to be placed on the jobcard, the name of a TSQ containing any parameter records being sent, the name of a TSQ containing any JCL found on the EDIRJCL file, the user ID of the individual requesting the submit, the reason for the submission, a return code for the exit, and a message area for the exit.

A sample program (EDISUBXT) demonstrates the proper procedure to use for the Batch Submit exit program. You must customize this program to perform the functions required at your site.

If the Batch Submit exit field is left blank on the Configuration Maintenance screen, the EDIB transaction writes the data to the internal reader.

Jump Codes

Jump Codes by Screen Title

The following table lists the jump codes for the Gentran:Control menus and screens. The screens are listed by title in the order in which they appear on the Gentran:Control menus.

See the next section in this appendix, “Jump Codes by Screen Name” for additional information.

Screen Title	Screen	Jump Codes	
	Name	Numeric	Alphabetic
Control Main Menu	EDIM300	7.0 7	CNTL
System Options Maintenance	EDIM301	7.1	CNTL.SOPT
Queue Directory	EDIM302	7.2	CNTL.QDIR
Queue Options Maintenance	EDIM303	7.3	CNTL.QOPT
Online Log Display	EDIM304	7.4	CNTL.LOG
Extended Queue Options Maintenance	EDIM305		CNTL.XQO
Queue Options Debug Detail	EDIM306		CNTL.DBG
Queue Options Data Display	EDIM307		CNTL.QDAT
Online Log Detailed Display	EDIM308		CNTL.LOGD
Separator Main Menu	EDIM934	7.5	CNTL.SEP
Separator Systems Options Maintenance	EDIM935	7.5.1	SEP.OPT.
Priority Options Directory	EDIM936	7.5.2	SEP.DIR
Priority Options Maintenance	EDIM937	7.5.3	SEP.MNT
Separator Monitor	EDIM938	7.5.4	SEP.MON

Jump Codes by Screen Name

The following table lists the jump codes for the Gentran:Control menus and screens. The screens names (EDIMXXX) listed are arranged strictly in alphanumeric order, regardless of the menu arrangement.

See the previous section in this appendix, “Jump Codes by Screen Title” for a listing of jump codes listed by screen title, in the order in which they appear on Gentran:Control menus.

Screen		Jump Codes	
Name	Screen Title	Numeric	Alphabetic
EDIM300	Control Main Menu	7.0 7	CNTL
EDIM301	System Options Maintenance	7.1	CNTL.SOPT
EDIM302	Queue Directory	7.2	CNTL.QDIR
EDIM303	Queue Options Maintenance	7.3	CNTL.QOPT
EDIM304	Online Log Display	7.4	CNTL.LOG
EDIM305	Extended Queue Options Maintenance		CNTL.XQO
EDIM306	Queue Options Debug Detail		CNTL.DBG
EDIM307	Queue Options Data Display		CNTL.QDAT
EDIM308	Online Log Detailed Display		CNTL.LOGD
EDIM934	Separator Main Menu	7.5	CNTL.SEP
EDIM935	Separator Systems Options Maintenance	7.5.1	SEP.OPT
EDIM936	Priority Options Directory	7.5.2	SEP.DIR
EDIM937	Priority Options Maintenance	7.5.3	SEP.MNT
EDIM938	Separator Monitor	7.5.4	SEP.MON

CICS Region Information

Overview

To transport data between CICS and batch environments and to initiate CICS and batch processing, the Gentran:Control online system uses standard CICS command-level functions and standard VSAM data set sharing features.

The Gentran:Control online system is comprised of the following two parts:

- **Conventional terminal-based file maintenance programs.**
These programs provide file maintenance functions for system options and monitoring. The file maintenance functions are nine, pseudo-conversational CICS command-level COBOL programs and nine BMS Map modules.
- **Non-terminal background CICS programs.**
These programs provide the data transport and initiation features. The transport and initiation features are nine background (non-terminal) CICS command-level COBOL programs.

CICS Region Requirements

Gentran:Control uses standard CICS facilities. However, it also relies on several specific settings for proper system operation.

File Integrity Considerations

Gentran:Control depends on the use of specific VSAM facilities to guarantee the integrity of files shared between CICS and batch. The following conditions must be satisfied:

- The Checkpoint file and the Queue file data sets must be defined with a disposition of share (e.g., DISP=SHR).
- The Checkpoint file and Queue file data sets must *not* be protected by any CICS recovery facility.

Naming Requirements

The Gentran:Control online system enables flexible CICS naming. The first three characters of all transaction IDs, data sets, TSQs, enqueues, and destination IDs default to EDI and may be modified.

See the section “Multiple System Image/Multiple Region Support” in Chapter 1 of this guide for information about how the system image ID concept operates.

Temporary Storage Requirements

Gentran:Control uses TSQs extensively to hold system status information and transaction data. The following list provides the approximate storage requirements for TSQs:

Static TSQ	Storage Requirement
EDIICF	8000 Bytes/system image
EDIQInnn	100 Bytes/Queue file
EDITSN	10 Bytes/system image

Transactional TSQ	Storage Requirement
EDITnnnn	Size of Document Group x the number of concurrent tasks (where <i>nnnn</i> is the counting number)

Enqueue Names

Gentran products (Basic, Realtime, Control, Viewpoint) use enqueues within CICS programs to control the processing of specific events and/or resources. Some examples of these events are: the updating of a specific file, updating or creating a TSQ (temporary storage queue), a unit of work (that comprises multiple files) or access to a specific shared resource.

When running in a single CICS region, the enqueues will be issued in that region and there is no need to create any specific entries for these enqueues. But when running in a CICSplex, where files may be in one CICS region and the processing programs can be executed from multiple regions, the enqueues must be defined to these regions so that the proper control of processing is activated. The method for defining these enqueues is through the use of the ENQMODEL in the CICS resource definitions. In the setup of an ENQMODEL, the names of the enqueues can be either listed completely or a wildcard naming convention can be used. For Gentran products the wildcard can be setup to be **GENTRAN-*** or **GENTRAN-EDI***. The * (asterisk) works as the wildcard position. The EDI is the system image for the Gentran installation. (See the CICS Resource Definition Guide for specific information about the ENQMODEL parameters.)

The following lists the enqueues used by the Gentran products.

Enqueues used by Gentran:Basic

Used in the accessing of the databanks.

Note: *b* indicates a blank space in the following names.

GENTRAN-EDIbOAbENQb
GENTRAN-EDIbIAbENQb
GENTRAN-EDIbOebENQb
GENTRAN-EDIbIEbENQb
GENTRAN-EDIOAAbbENQ
GENTRAN-EDIOALbbENQ
GENTRAN-EDIOAPbbENQ
GENTRAN-EDIIAAbbENQ
GENTRAN-EDIIPbbENQ
GENTRAN-EDIOEAbbENQ
GENTRAN-EDIOEPbbENQ
GENTRAN-EDIIEAbbENQ
GENTRAN-EDIIEPbbENQ
GENTRAN-EDIIELbbENQ
GENTRAN-EDIOASbbENQ
GENTRAN-EDIIASbbENQ
GENTRAN-EDIOESbbENQ
GENTRAN-EDIIESbbENQ
GENTRAN-EDIOASbbENQ
GENTRAN-EDIIASbbENQ
GENTRAN-EDIOACAAbENQ
GENTRAN-EDIACAAbENQ
GENTRAN-EDIOECAAbENQ

GENTRAN-EDIIECAbENQ

GENTRAN-EDIX290bENQ

Used in the accessing of TSQs and TDQs.

GENTRAN-EDIOLFbbENQ

GENTRAN-EDIibENQ

GENTRAN-EDICFGQbENQ

Enqueues used by Gentran:Realtime and Gentran:Control

Used in the accessing of Realtime databanks and databank resources.

GENTRAN-EDIOAbDBKbMAINT

GENTRAN-EDIOEbDBKbMAINT

GENTRAN-EDINRCbbENQ

GENTRAN-EDIRNRCbENQ

GENTRAN-EDIIEbDBKbMAINT

GENTRAN-EDIIAbDBKbMAINT

GENTRAN-EDIRDARbENQ

GENTRAN-EDICAbMAINT

GENTRAN-EDIRIAAbENQ

GENTRAN-EDIRIASbENQ

GENTRAN-EDIRIEAbENQ

GENTRAN-EDIRIELbENQ

GENTRAN-EDIRIESbENQ

GENTRAN-EDIROAAbENQ

GENTRAN-EDIROALbENQ

GENTRAN-EDIROASbENQ

GENTRAN-EDIROEAbENQ

GENTRAN-EDIROESbENQ

Used in the accessing of Realtime reporting subsystem.

GENTRAN-EDICRRDIENQ

GENTRAN-EDIRRDbbENQ

GENTRAN-EDIRRCbbENQ

Used in the accessing of internal tables.

GENTRAN-EDIdaaaaaaaaa

Where *d* is either **R** or **S** and *aaaaaaaa* is the Application data ID.

GENTRAN-EDIdtttttttt

Where *d* is either **R** or **S** and *tttttttt* is the Translation Map id.

GENTRAN-EDITBLbbENQ

Used in the control of Realtime translations.

GENTRAN-EDIOUTBOUND-GENTRANbbbbENQb*desc*val*i*

Where *desc* is a description (either **PATH** or **OPTN**), *val* is the option number, and *i* is a counter.

Enqueue Names

GENTRAN-EDIINBOUND-GENTRANbbbbENQbdescbvali

Where *desc* is a description (either **PATH** or **OPTN**), *val* is the option number, and *i* is a counter

Used in the control of Realtime files, TSQs and events.

GENTRAN-EDIOSIbbENQ
GENTRAN-EDIICFbbENQ
GENTRAN-EDICKPQbENQ
GENTRAN-EDIICFCbENQ
GENTRAN-EDIICFIbENQ
GENTRAN-EDIMNHbbENQ
GENTRAN-EDIMNSbbENQ
GENTRAN-EDIREQbbENQ
GENTRAN-EDIRSEPbENQ
GENTRAN-EDITSNSbENQ
GENTRAN-EDISEPQbENQ

Used in the control of queue file processes.

GENTRAN-EDIQ###bENQ
GENTRAN-EDIQI###ENQ

Where ### is the queue file number.

Enqueues used by Gentran:Viewpoint

GENTRAN-EDICOMMbPROCbENQ
GENTRAN-EDIVIEWPOINTbbENQ
GENTRAN-EDIPOSTbPROCbENQ
GENTRAN-EDIVPPXbENQ
GENTRAN-EDIVPSYSTEMbENQ
GENTRAN-EDIitemtag123bENQ

Where the *itemtag123* is a variable area that is set by the programs.

GENTRAN-EDIXVSQENQ

Temporary Storage Queues

Gentran products (Basic, Realtime, Control, Plus and Viewpoint) use TSQs to hold data, parameters, tables and control information. In some cases the information is temporary (passed from one program to another or from one iteration of a program to the next), other times the information is retained for a particular processing run (such as a series of programs in an inbound translation) or the information is retained throughout the entire processing period of the system (i.e. from CICS system initiation until the CICS region is shutdown).

When running in a single CICS region, the TSQs will be defined in that region and there is no need to create any specific CICS entries for these TSQs. But when running in a CICSplex, where files may be in a file owning region, TSQs in TSQ owning region and the programs can be executed from multiple application owning regions, some of the Gentran TSQs must be defined as REMOTE TSQs in the application regions so that Gentran programs can find the TSQs. In addition if dynamic program link (DPL) is used within the CICSplex then TSQs that are used between the programs will also have to be defined properly.

To properly define the TSQs the CICS systems will require either a TST definition (for CICS 4.1 and previous versions) or a TSMODEL definition (for CICS Transaction Server) (See the CICS Resource Definition Guide for your version of CICS to obtain more information).

The following lists will identify the naming conventions used by Gentran and whether a CICS definition will be required for this TSQ name.

Terminal oriented TSQs

These are used as scratch pad areas to hold temporary information that does not need to be recovered or reside in a specific TSQ owning region. The TSQ names start with a 4 character constant and have the terminal ID as the last 4 characters of the name.

- EDIT $tttt$
- EDID $tttt$
- EDI $tttt$
- EDIG $tttt$
- EDIM $tttt$
- EDIH $tttt$

(where $tttt$ is the terminal id.)

Note: The leading three characters (**EDI** in this example) are the system image for the Gentran system. All TSQ names in the following examples that have EDI as the first three characters will change to have the system image. TSQ names that start with other characters do not change for different system images.

Temporary Storage Queues

Temporary data TSQs

These TSQs are passed between programs. One program will create the TSQ and write data from a file to it and the second will process the data and then delete the queue. In these cases the data does not have to be recoverable and it would only have to be defined if DPL is being used.

Note: In all these cases the data is created by a terminal application.

- APPL*tttt*
- APHD*tttt*
- APRT*tttt*
- APFD*tttt*
- CDAL*tttt*
- CDCD*tttt*
- CDDF*tttt*
- CDDA*tttt*
- CDVL*tttt*
- TRAN*tttt*
- TRHD*tttt*
- TRSG*tttt*
- TREL*tttt*
- APTR*tttt*
- PART*tttt*

(Where *tttt* is the terminal id).

Naming process TSQs

These TSQs are used to hold information that is used by programs to create unique TSQ names. These are constant names and should be placed in a specific TSQ owning region. For performance regions place these in Main storage.

EDIXTSNS	provides a 4 character alpha-numeric field
EDIXTSNR	provides a 4 digit number
EDIXVSQN	provides a 4 digit number

Data passing TSQs

Note: The following TSQs use a naming convention where *ssss* is a sequential alpha-numeric code retrieved from the EDIXTSNS TSQ; *rrrr* is a sequential number retrieved from the EDIXTSNR TSQ; and *vvvv* is a sequential number retrieved from the EDIXVSNQ TSQ.)

These TSQs are used to pass data between processes in the Realtime and Control systems. In most cases the TSQ name is passed in linkage when one program links to another. But in some cases a start command is used to initiate a new transaction. These TSQs should be defined in a TSQ owning CICS region if Gentran can be executed in multiple application owning regions.

- EDI1*rrrr*
- EDI2*rrrr*
- EDI3*rrrr*
- EDI4*rrrr*
- EDI5*rrrr*
- EDI6*rrrr*
- EDI7*rrrr*
- EDI8*rrrr*
- EDI9*rrrr*
- EDIA*rrrr*
- EDIB*rrrr*
- EDID*rrrr*
- EDIE*rrrr*
- EDIF*rrrr*
- EDIR*rrrr*
- EDIS*rrrr*
- EDIU*ssss*
- EDIV*vvvv*
- EDIY*ssss*

Control information TSQ

These TSQs are used to hold temporary control information that will be used in processing. Gentran programs will use these TSQs to hold information that will be used to process data TSQs. These TSQs should be defined in a TSQ owning CICS region.

- EDIK*ssss*
- EDIK*rrrr*
- EDIL*rrrr*

Constant TSQs

These TSQs are defined with a constant name and will (once they are created) reside for the duration of the system. (i.e. until Realtime is disabled or the full CICS region is shutdown.) These should be defined within a TSQ owning region.

Temporary Storage Queues

- EDICABND
- EDICAPPL
- EDICKPQ
- EDICMAPS
- EDICRMTS
- EDICrrrr
- EDICssss
- EDICFGQ
- EDICRRDI
- EDICEXIT
- EDICQ091
- EDICQ093
- EDICQ095
- EDICQ097
- EDIICF
- EDIICFC
- EDIICFI
- EDIPpppx (where *ppp* is a Realtime Option number and *x* is a suffix.)
- EDIQqqq (where *qqq* is a Queue File number)

Reporting subsystem TSQs

These TSQs hold reports and report parameters that are generated by Realtime programs. They are passed in a communication area to a transaction (EDIQ) that writes the reports to the reporting subsystem VSAM files. They should be defined in the TSQ owning region if CICSplex is being used and the Realtime system can run in multiple CICS regions.

- EDIQrrrr
- EDIZrrrr

Recommendations

The simplest method to use for providing for TSQ uniqueness and access is to define all TSQs that begin with 'EDI' in a specific TSQ owning region. This will exclude only the temporary data TSQs. Another set that could possibly be excluded would be the terminal oriented TSQs.

CICS Abend Codes

Gentran:Control uses the following CICS abend codes when its background CICS tasks are unable to issue messages to the Gentran:Control Online Log file.

- EDIA
- EDIB
- EDIE

See Appendix A in the *Gentran:Basic for zSeries Release 6.4 System Message Guide* for additional information.

Flow Charts

The flow charts in this appendix illustrate various Gentran:Control processes.

Note: For system architecture flow charts, see the “Getting Started” chapter in this guide.

The following conventions are used throughout the appendix:

- A number in a flow chart box indicates the sequential order of processing.
- Batch flow chart box illustrations contain the program name at the top of the box, and execution JCL member at the bottom of the box.
- User-written programs are identified by the key word “User” as part of the program description.
- Files are identified by DDname or a file description.

Gentran:Control Queue File Maintenance

The following chart describes Gentran:Control Queue File Maintenance.

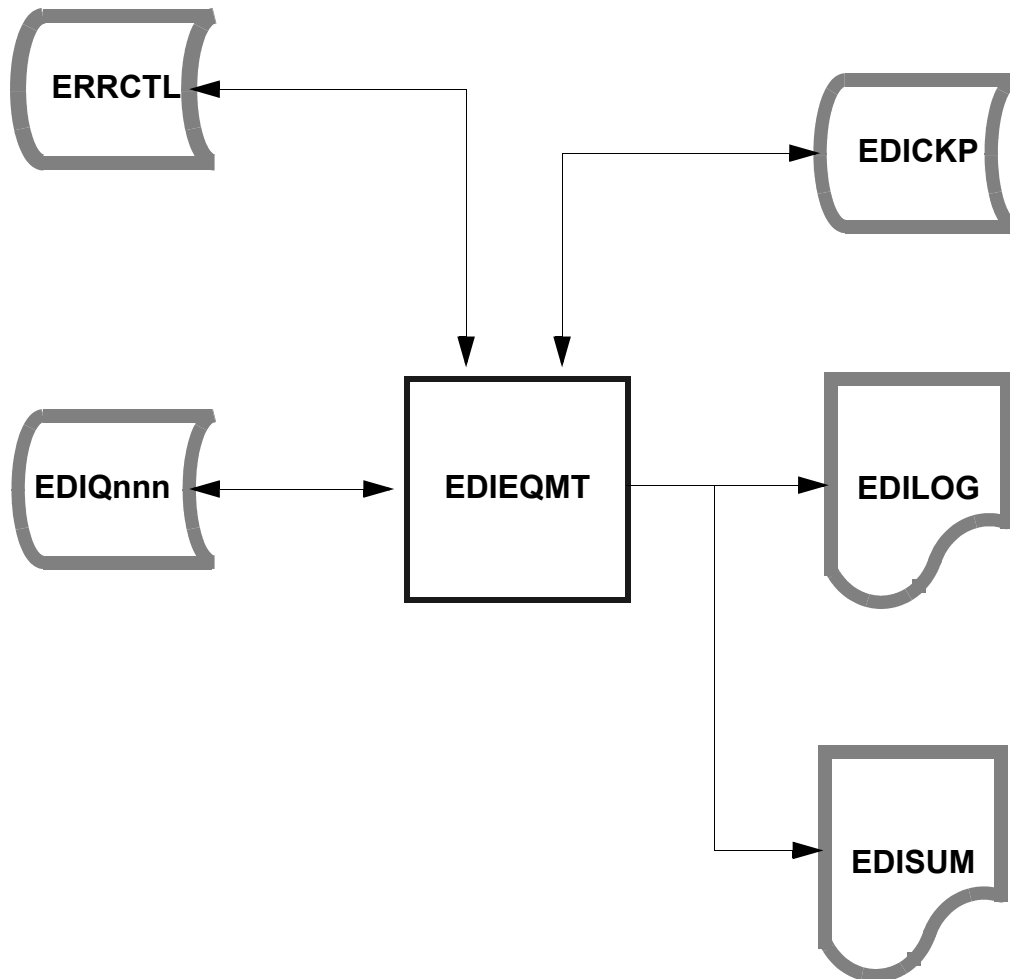

Gentran:Control Screen Flow

The following chart describes Gentran:Control screen flow.

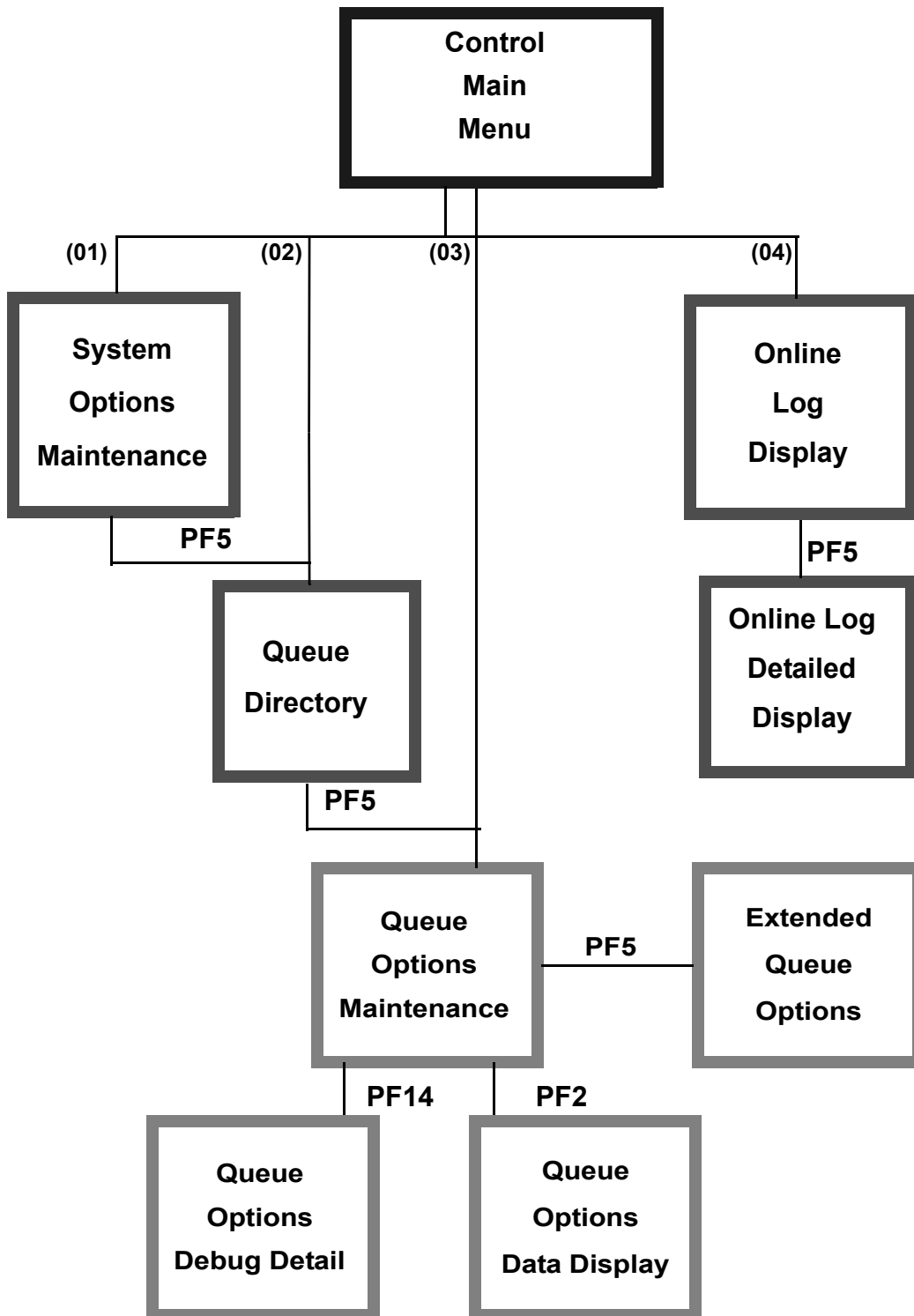

Gentran:Control Initialization Processing Flow

The following chart describes Gentran:Control initialization processing flow.

CICS

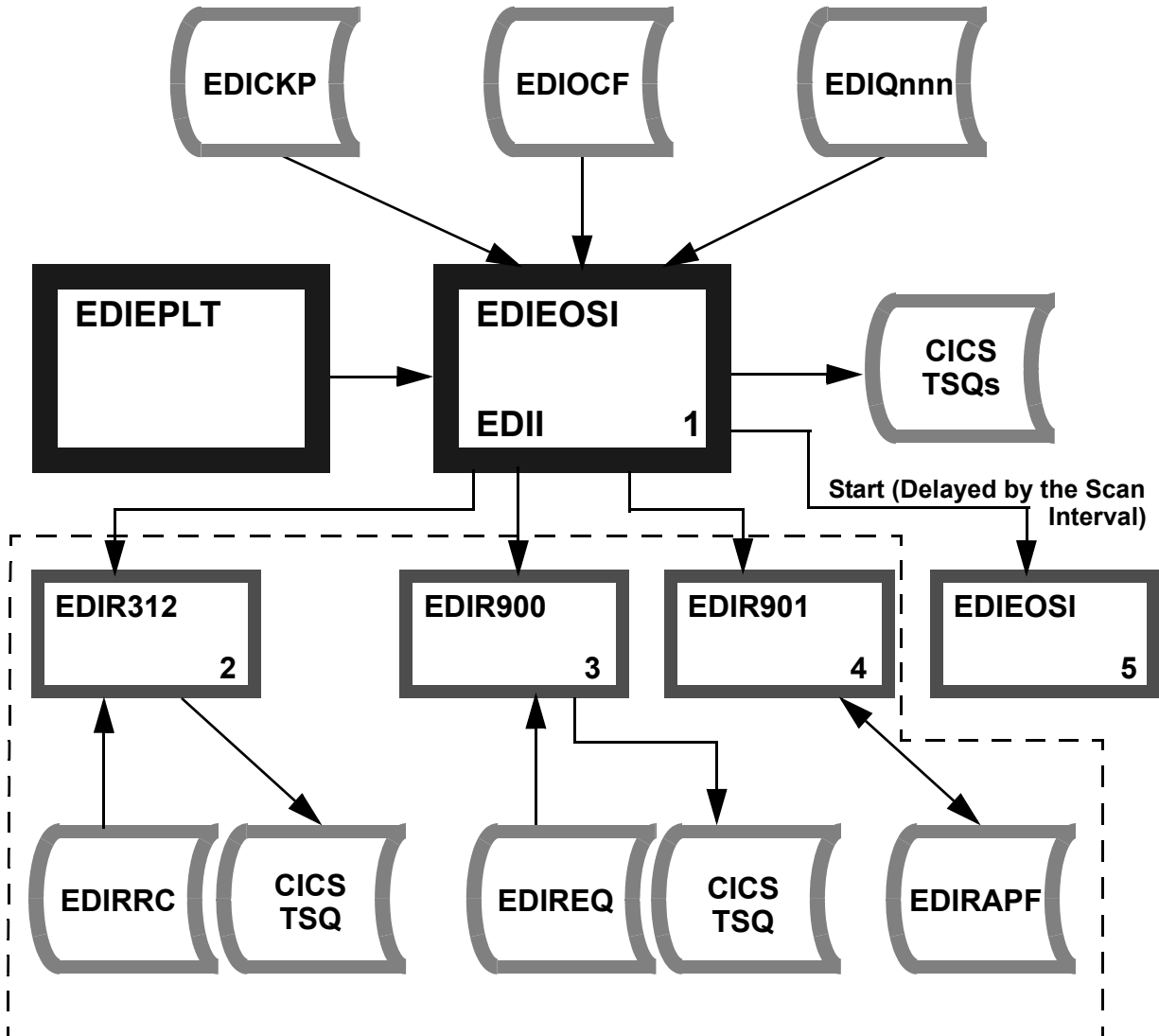

Note:
 All flow chart components within the dotted line are present within processing only if Gentran:Realtime is installed.

Gentran:Control Online Scanner/Initiator Scan Processing Flow

The following chart describes the Gentran:Control online scanner/initiator scan processing flow.

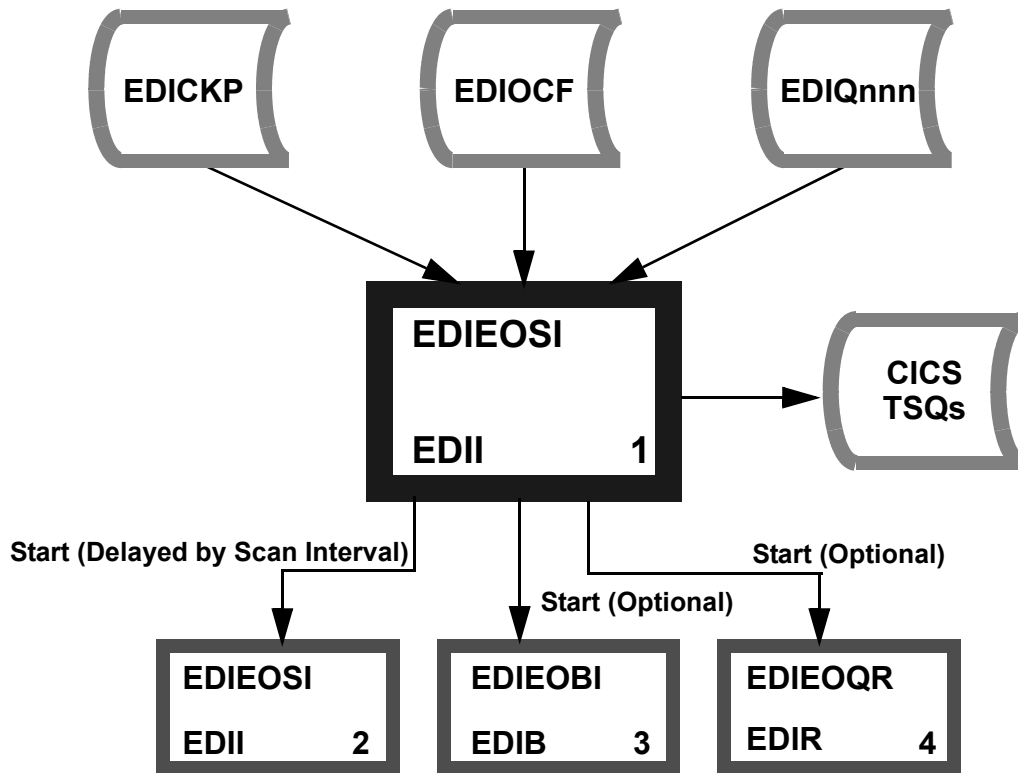

Batch Application to Online Application

Gentran:Control Queue File Processing Flow

The following chart describes the batch Application to online Application Queue file process.

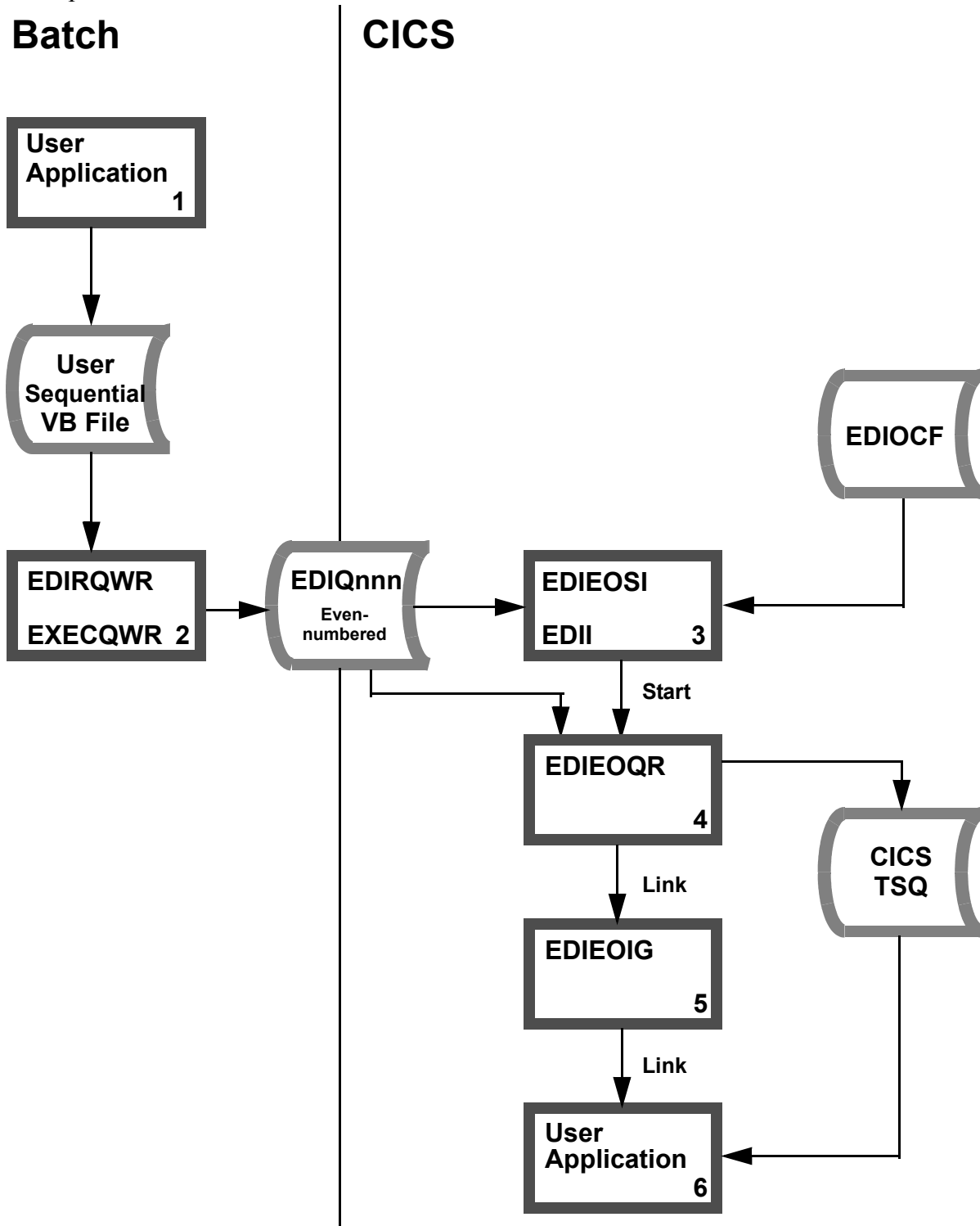

Online Application to Batch Application

Gentran:Control Queue File Processing Flow

The following chart describes the online Application to batch Application Queue files.

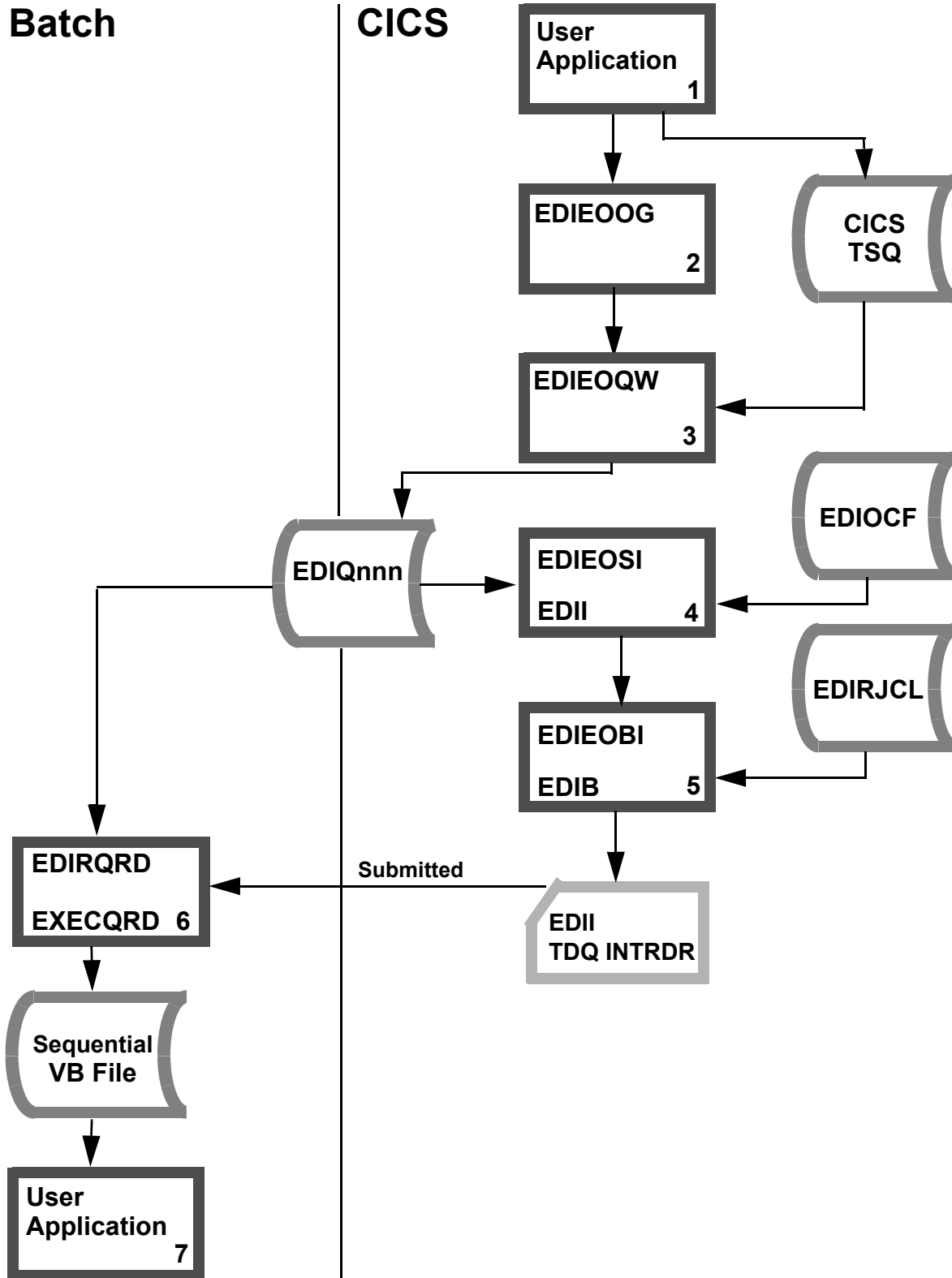

Outbound Translation Batch Application to Batch

Communications Gentran:Control Queue Files Processing Flow

The following chart describes the Outbound translation batch Application to batch communications process.

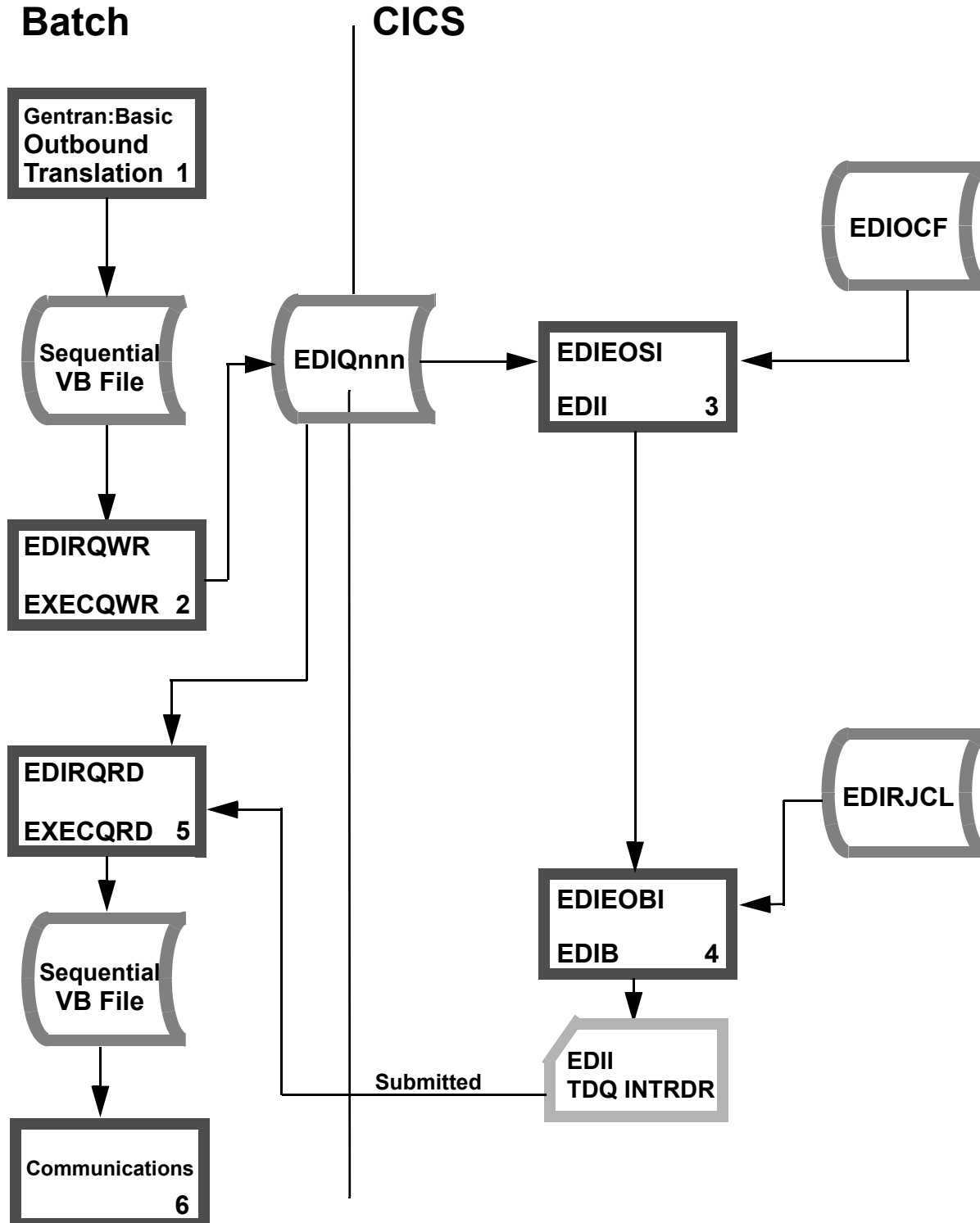

Gentran:Control Message Handling and Logging Processing Flow

The following chart describes Gentran:Control message handling and logging.

CICS

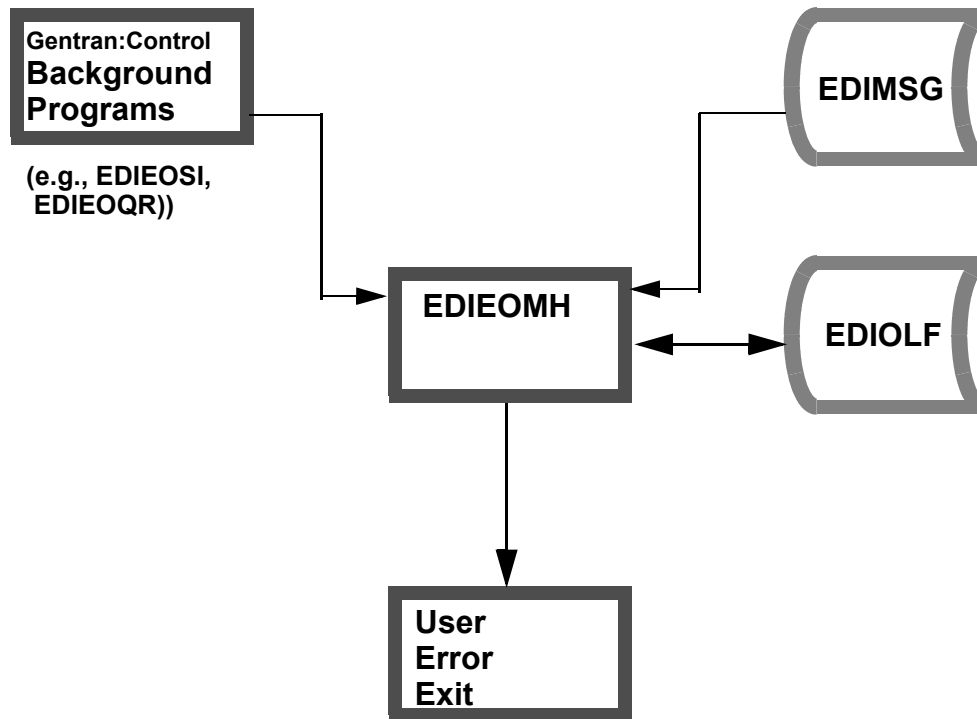

Gentran:Plus to Gentran:Control Interface to User Application

The following chart describes the flow from Gentran:Plus to Gentran:Control interface to User Application.

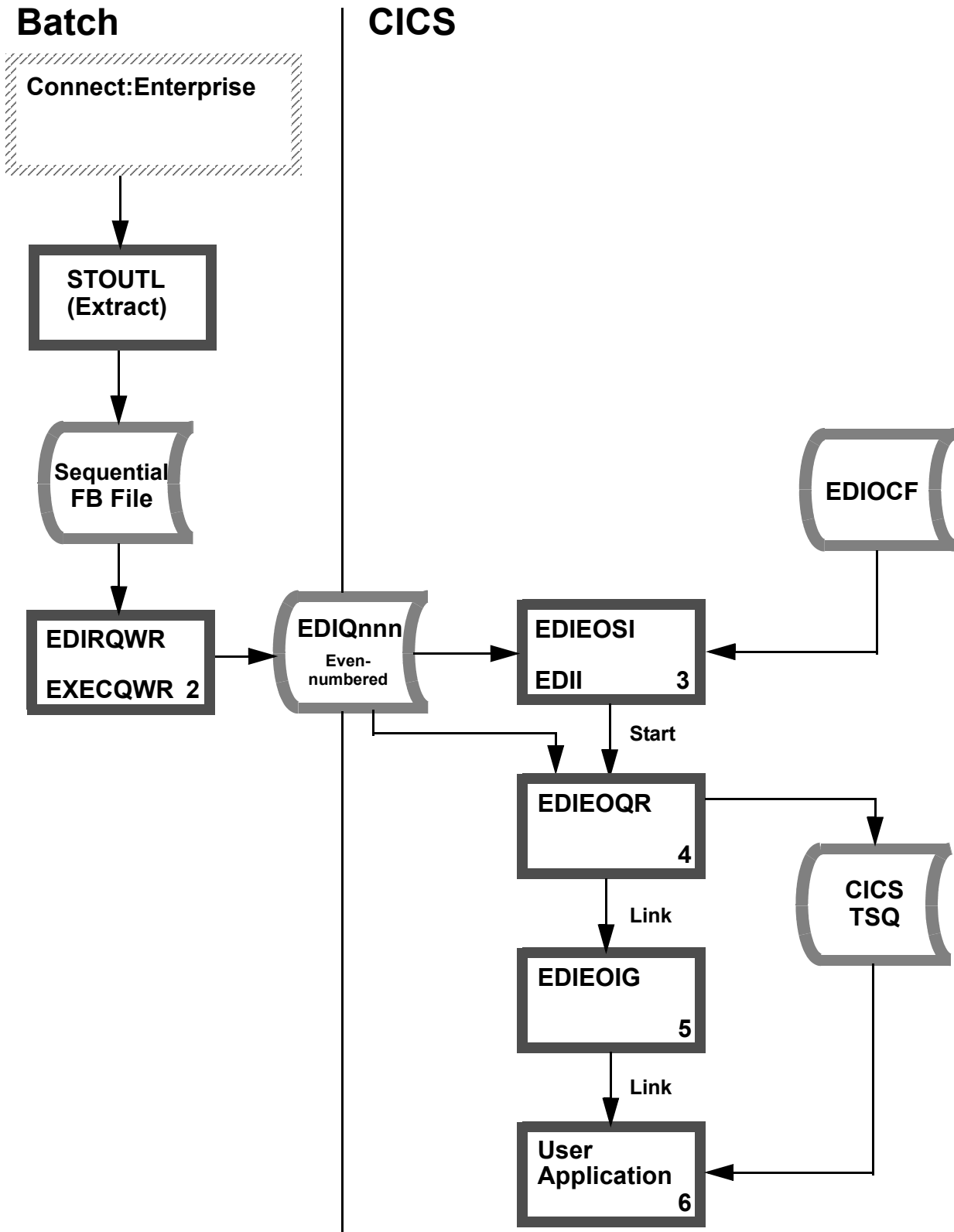

Gentran:Basic to Gentran:Control to Connect:Enterprise

The following chart describes the flow from Gentran:Basic to Gentran:Control to Connect:Enterprise.

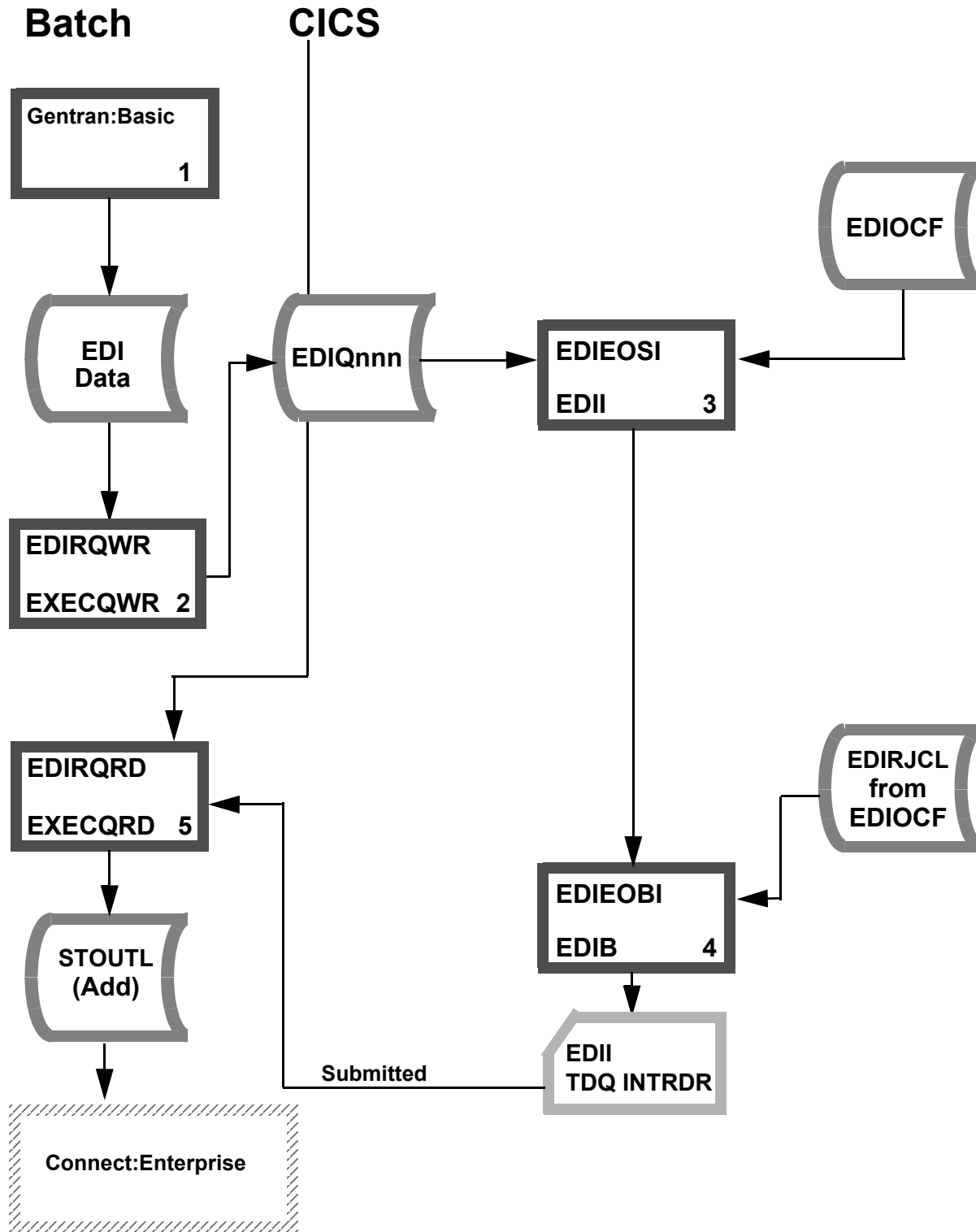

Gentran:Control Separator Processing Flow

The following chart describes the Gentran:Control separator processing flow.

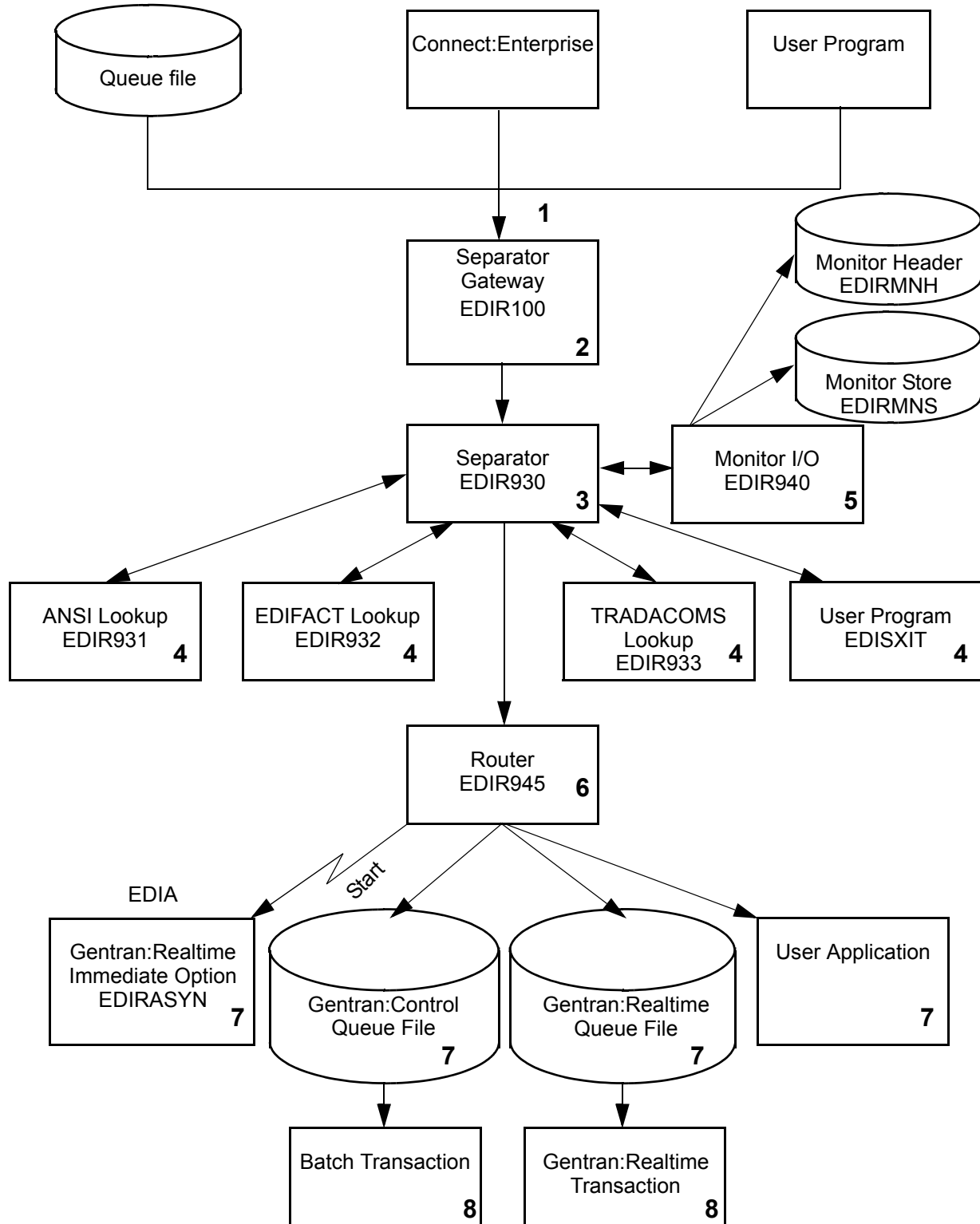

Glossary

See the Glossary in the *Gentran:Basic for zSeries Release 6.4 User's Guide* or *Technical Reference Guide* for additional terms and definitions related to Gentran processing.

Check-point

A logical point within a process at which recovery of resources (files) can be performed. Recovery involves removal of some or all of the updates that have been made during a process in which an error occurred (updates may not be removable based on how the file is defined). Without check-points, any error within a process can cause all updates to be removed. With check-points, errors cause only a backup to the last check-point; thus, the entire process need not be re-run.

Control Interval

The physical record on a VSAM file.

Criteria

Specific options (e.g., a filename, Queue file number) that a program is to use when performing its requested operation, according to information entered on control cards.

Document Group

The group of documents that are processed together as a logical work unit. The Document Group can be comprised of one or more application documents, or one or more EDI interchanges.

Error Level

The value in a two-position numeric field indicating the highest level of error encountered during a process.

Gateway

Interface programs that user applications and communications link to in order to write data to Queue files or to receive data from Queue files.

Gentran:Control

An add-on product to Gentran:Basic that enables you to automate the EDI processing stream and prioritize processing by Trading Partner and/or type of document. Gentran:Control enables you to organize processing and responsiveness based upon business criteria, not system limitations. In addition, the application and communications gateways expedite the movement of documents across the batch/CICS barrier.

Gentran:Plus

A comprehensive software system that provides a seamless application-to-EDI interface. Gentran:Plus can work in conjunction with Gentran:Basic, or as a stand-alone product. Gentran:Plus contains these three subsystems: Communications, Translation, and Communications Setup and Management. Gentran:Plus can accommodate an unlimited number of transactions while using an unlimited number of EDI standards versions. It supports multiple lines with different protocols for concurrent EDI sessions. This combination of translation, communications, and mailboxing represents a highly efficient EDI resource that can be used to automate your communications needs.

Gentran:Realtime

An add-on product to Gentran:Basic that facilitates the transmission of data processing in an operating mode when data is entered in an interactive session, rather than a batch session. Response time is drastically reduced over batch processing, providing the competitive benefits of online speed, flexible control, and universal EDI standards to many business applications.

Gentran:Structure

An add-on product to Gentran:Basic that enables you to define proprietary fixed-format standards using the Standards subsystem, and to map to and from these standards using the Inbound and Outbound Mapping programs.

Gentran:Viewpoint

A Gentran product that consists of these two modules: Exception Management and Tracking Management. Exception Management enables you to capture exception information, notify the appropriate user, and optionally take automated action for exceptions that are specific to their EDI business needs. Tracking Management is an optional module that enables you to query on the status and history of a document as it moves through the entire end-to-end EDI environment.

Interface

A utility program or subroutine that the user either executes with parameters or calls through a program that provides access to Gentran:Control Queue files.

Just-In-Time

Processing within organizations that maintains operations in such a way that materials arrive “just in time” to keep manufacturing or other processes functioning (e.g., materials are not stocked, they arrive as-needed for production).

Pointer

A field on a record that addresses the location of data.

Queue File

The VSAM RRDS data sets used to store data in Gentran:Control operations.

Requested Operation

The specific logical process (e.g., format, read, write) that the program is to perform during an execution, according to information entered on control cards.

Server

The process that uses the data stored on a Queue file (e.g., data is read from the Queue file and sent to this process).

Source

The process that places data on a Queue file.

Status Code

The value entered in a two-position numeric field indicating the status of a link to a gateway. This value is set according to special messages (not necessarily errors) that occur during processing.

Temporary Storage Queue (TSQ)

A dynamic facility within CICS that enables you to create a name that uniquely identifies a set of data. TSQs are used to pass data between applications and between programs within the same application.

Time Interval

The elapsed time between runs of the Online Scanner/Initiator program, or the time between executions of the Action to Initiate for a Queue file.

Translation Subsystem

The Gentran:Basic software system that validates EDI standards, performs compliance checking, performs mapping to and from EDI standards, performs error rejection, completes acknowledgment processing, and enables file splitting in Gentran:Plus.

Trigger Level

The point at which the Action to Initiate is started for a Queue file. Trigger level can be based on document counts or time switches.

Unit of Work

The amount of work (documents of EDI interchanges) that are sent to or received from Gentran:Control during an individual process or program execution.

Index

A

acknowledgment
 see Glossary

activity
 monitoring 1-2
 viewing in realtime 3-25

add-on products
 see GENTRAN:Control, GENTRAN:Plus,
 GENTRAN:Realtime,
 GENTRAN:Structure,
 GENTRAN:Viewpoint in Glossary

alphabetic jump codes 3-3

application
 maintenance 1-2

application data
 processing via EDIEOOG 4-37
 reading from Queue files 4-9
 received for processing 4-46
 transfer via EDIEOOG 4-37
 writing to Queue files 4-19

application ID
 see Glossary

application interface
 passing error messages 4-56
 see gateway

Asynchronous Program (EDIRASYN) 4-15

Automatic System Start-Up program (EDIEPLT)
 4-62

B

background activity
 CICS, monitoring 1-13

background tasks
 user ID for 6-2

batch
 interfaces 1-4

batch applications
 reading Queue files 4-24
 writing to Queue files 4-31

batch interfaces 1-4

batch jobs
 initiation 1-4

batch processing
 initiated by Online Scanner/Initiator program
 4-60
 initiation 4-59

batch programs
 reading Queue files 4-30
 writing data to Queue files 4-36

Batch Submit exit 6-2

Batch Wait Utility program (EDIWAITD) 4-14

C

Central Multi-Queue routines 1-9

check-point
 see Glossary

Checkpoint file 1-9, 1-19, 5-2
 corrupted 5-3
 disposition B-2
 frequency of activity 5-2
 pointer values 5-2
 Queue file records 5-2
 size allocation 5-2
 system status information 5-2
 updating 5-2

CICS
 and Online Log file 1-4
 background activity, monitoring 1-2, 1-13
 background automation 1-23
 background errors 1-3, 1-4, 1-24
 background transactions 2-12
 gateways 1-2
 input and output gateways 1-4
 multiple regions 1-4, 1-14
 naming B-2
 processing, batch 1-2
 region information B-1
 region requirements B-2
 task initiation 1-4

CICS initialization
 Automatic System Start-Up program
 (EDIEPLT) 4-62

CICS Program Descriptions
 EDIFACT Interchange Priority Lookup -
 EDIR932 4-69
 Monitor I/O - EDIR940 4-71
 Multi-Queue Read Subroutine - EDIRCMR
 4-4
 Multi-Queue Write Subroutine - EDIRCMW
 4-5
 Queue File Maintenance - EDIEQMT 4-6
 Router - EDIR945 4-72
 Separator Driver - EDIR930 4-66
 TRADACOMS Interchange Priority Lookup
 - EDIR933 4-70
 X12 Interchange Priority Lookup - EDIR931
 4-68

comment cards 4-3

communications, EDI 1-2

concurrent processing
 restrictions 1-12

Configuration file, updating 2-3

control cards 1-28, 1-30, 1-32
 criteria 4-3
 empty files 4-3
 enabling Queue Read program 4-9
 enabling Queue Write program 4-19
 format 4-3
 parameters 4-3
 request 4-3
 requested operation 4-3
 rules 4-3

control information, for Queue files 4-6

control interval
 see Glossary

Control Main Menu (EDIM300) 3-6–3-7

control number
 see Glossary

criteria 4-3
 see Glossary

D

data
 batch/CICS transport 1-26
 inbound EDI 1-12
 incoming 1-31

 outbound 1-12
 responsible for errors 4-56
 storage in Queue files 5-6

data dictionary
 see Glossary

data set, sharing 1-9, 1-17

databank
 see Glossary

Dataset Descriptions and Space Requirements
 Monitor Store File – EDIRMNH 5-9

debugging 1-24

defaults
 in a program 4-3

document
 CICS/batch transport 1-2
 exchange 1-2, 1-4, 1-7, 1-14
 queueing 1-2, 1-4
 trigger levels 1-13

Document Group 1-17
 becoming a Unit of Work 1-17, 1-18
 components 1-17
 examples ??–1-23
 processing, bypassing 4-53
 see Glossary
 with errors, processing 4-53

E

EDI
 CICS-based applications 1-1
 CICS-driven system 1-2
 communications 1-2
 communications configuration 1-2
 system configuration 1-4, 1-13
 time-critical requirements 1-1, 1-2

EDI data
 processing via EDIEOOG 4-37
 reading from Queue files 4-9
 received for processing 4-46
 transfer via EDIEOOG 4-37
 writing to Queue files 4-19

EDIB 3-28, 6-2

EDIEQMT 4-6

EDIFACT Interchange Priority Lookup -
 EDIR932 4-69

EDII transaction
 assigning user ID 6-2

EDIM306 for even-numbered Queue files 3-34

EDIM306 for odd-numbered Queue files 3-39
 EDIR 6-2
 EDIR100 4-64
 EDIR930 4-66
 EDIR931 4-68
 EDIR932 4-69
 EDIR933 4-70
 EDIR940 4-71
 EDIR945 4-72
 EDIR999 4-73
 EDIRCMR 4-4
 EDIRCMW 4-5
 EDIRMNH 5-8
 EDIRMNS 5-9
 EDIRQRD - Queue Read program 4-9
 Error Code field 3-30, 3-49
 error codes
 return code values 3-30, 3-49
 severity indicator values 3-30, 3-49
 error handling 1-4
 via Online Error User Exit program
 (EDIEXIT2) 1-23
 error level
 see Glossary
 Error Message field 3-30, 3-48
 error messages 2-12
 generating programs 4-56
 in background processing 2-12
 multiple 4-57
 passing to user systems 4-56
 error reporting 1-2, 1-3, 1-13, 1-23, 3-24
 Error User Exit Pgm field 4-56
 Error User Exit Program field 3-10
 Exception Exit program (EDIEXIT1) 4-53
 designing 4-53
 Exception Pgm field 3-23, 4-53
 Extended Queue Options Maintenance screen
 (EDIM305) **3-31–3-33**

F

file integrity B-2
 file maintenance 1-2
 CICS-based 1-4, 1-13
 file protection 1-17
 flow charts C-1

G

gateway 1-2
 input and output 1-12
 see Glossary
 Gentran logon screen 2-3
 Gentran:Basic
 Inbound Application Extract program
 (EDID405) 1-2
 Outbound EDI Extract program (EDID205)
 1-2
 system status 5-2
 GENTRAN:Control
 coding sample 4-63
 flow charts C-1
 initializing online system 4-60
 input/output routines
 Central Multi-Queue routines 1-9
 Online Single-Queue routines 1-9
 queue status information 1-9
 Remote Single-Queue routines 1-9
 maintenance screens data storage 5-4
 naming requirements B-2
 Online Control file 5-4
 parameter information 5-4
 processing 1-1
 Queue file architecture 1-11
 restarting when defining a Queue file 2-28
 security 2-4
 see Glossary
 Separator features 3-51
 setup and maintenance functions 3-7
 system activity status 3-46
 system activity, status viewing 3-25
 system architecture 1-26
 system demonstration 4-63
 system operation, examples 1-28
 Gentran:Control
 Automatic System Start-Up program
 (EDIEPLT) 4-62
 batch/CICS data passage 5-6
 Checkpoint file 5-2
 system activity status 5-2
 GENTRAN:Plus
 see Glossary
 GENTRAN:Realtime 3-10
 see Glossary
 System Options record replacement 3-10

GENTRAN:Structure
 see Glossary
GENTRAN:Viewpoint
 see Glossary

H

header
 see Glossary

I

Inbound Application Extract program (EDID405)
 1-2
in-house interface
 see Glossary
Init Act field 2-10
initiation action, processing 2-11
Initiation Actions fields 3-22
 and trigger levels 3-22
initiation control 1-2
input/output routines 1-9
interface
 batch 1-4
 in-house
 see Glossary
 see Glossary
 to user automation systems 1-2

J

JCL
 submitting, configuring 6-2
JCL submission 1-13
JCL submit transaction (EDIB) 6-2
JCL/Trans field 2-10
jump codes **3-2–3-5**, A-1–A-2
 alphabetic 3-3
 by screen name A-2
 by screen title A-1
 guidelines 3-5
 invalid 3-5
 numeric 3-3
 special character 3-3
 SWAP 3-4, 3-5

Just-In-Time 1-1
 see Glossary

M

maintenance, application 1-2
message
 viewing 2-12, 3-46
Monitor Header file (EDIRMNH) 2-17, 3-66
Monitor I/O - EDIR940 4-71
Monitor Store File – EDIRMNH 5-9
Multi-Queue Read Subroutine - EDIRCMR 4-4
Multi-Queue Write Subroutine - EDIRCMW 4-5

N

navigation, screen-to-screen 3-2
numeric jump codes 3-3

O

Online Batch Initiator program (EDIEOBI) 1-4,
 4-59
 in GENTRAN:Control initiation 1-26
 initiation of CICS tasks and batch jobs 1-13
Online Control file 1-13, 3-31, 5-4
 activity 5-4
 backup 5-5
 contents 5-4
 JCL specified on 4-59
 parameters 1-13
 recreating 5-4
 space requirements 5-5
 updating parameters 3-8, 3-31
 viewing Queue files in 3-12
Online Error User Exit program (EDIEXIT2) 1-3,
 1-4, 1-23, 4-56
online file maintenance 1-4
Online Input Gateway 1-4, 1-24, 1-27, 1-29, 4-46
 calling Sample Online Application program
 4-63
 in Queue file architecture 1-10
Online Input Gateway program (EDIEOIG,
 EDIEOQR) 4-46
Online Log Detailed Display screen (EDIM308)
 1-24, **3-46–3-49**

Online Log Display screen (EDIM304) 1-13, 1-24, **3-25–3-30**

Online Log file 1-13, B-9
viewing 3-25

Online Message Handler program (EDIEOMH) 3-24
calling Online Error User Exit program 4-56

online operational features 1-4

Online Output Gateway 1-4, 1-21, 1-24, 1-26, 1-28, 1-29, 4-37
called by Sample Online Application program 4-63
in Queue file architecture 1-10
multiple links to 4-38
starting Online Batch Initiator 4-59

Online Output Gateway program (EDIEOOG, EDIEOQW) 4-37

online processing, initiated by Online Scanner/Initiator program 4-60

Online Queue Read subprogram (EDIEOQR) 3-23
calling Exception Exit program 4-53
generating error messages 4-56
started by Online Scanner/Initiator program 1-27
working with Online Input Gateway program 4-46

Online Queue Write subprogram (EDIEOQW)
in system operation 1-29
working with Online Output Gateway program 4-37

Online Scanner/Initiator
and trigger levels 3-19

Online Scanner/Initiator program (EDIEOSI) 1-4, 4-60
controlling via System Options Maintenance screen 2-9
in Queue file definition 2-26
in system architecture 1-27
initiation of batch jobs 1-13
initiation of CICS tasks 1-13
starting 4-60
starting Online Batch Initiator program 4-59
using Source field value 3-14, 3-18

Online Single-Queue routines 1-9

online system control 1-4

online system maintenance 3-51

Outbound EDI Extract program (EDID205) 1-2

P

parameters
adding, updating, or deleting 3-16
file maintenance 1-2
Online Control file 1-13, 3-16
queue-level 3-6
time interval 3-31
system 3-6
system-level
scan interval 1-13
system status 1-13
viewing and updating 3-8
updating 3-31
used by CICS/GENTRAN:Control 5-4

password, changing 2-3

pointer
see Glossary

pointer values
records in Checkpoint file 5-2

pointers 1-7, 1-9, 1-18
updated 1-7
updating by EDIEOQR 4-53

position, in jump code usage 3-2

Priority Options Directory screen (EDIM936) **3-59–3-61**

Priority Options Maintenance screen (EDIM937) **3-62–3-65**

processing 1-2
activity
monitoring 1-2
viewing in real-time 3-25
background 2-12
batch 1-13
immediate 1-12
between Queue files 1-12
Checkpoint file 5-2
CICS functions B-1
CICS/batch 1-2
concurrent 1-12
controlling via Queue Options Maintenance screen 2-11
enabling/disabling 3-9
errors 3-23
initiating 1-13, 2-11, 4-60
batch 1-13, 4-59, B-1
CICS 1-13, B-1
initiation control 1-2
initiation criteria 1-13

- interval times 1-13
- Queue file records 5-2
- Queue file, wrap-around 1-7
- Queue file, wrap-around 1-9
- restrictions 1-12
- setting the scan interval 3-10
- setting time limits 3-31
- stall limit 3-18
- stalls 3-10
- trigger levels 1-13, 2-11, 3-19
- VSAM data set sharing features B-1

program defaults 4-3

Program List Table 4-60, 4-62

Q

queue

- facility, explained 1-4
- function 1-4, 1-7
- record 1-7
- sending and receiving data 1-7
- server process 1-8
- source process 1-8
- status information 1-9

Queue Directory screen (EDIM302) **3-12–3-15**

Queue file

- access 1-9, 5-6
- accessing via EDIERSW 4-36
- activity 5-6
- architecture 1-10, 1-11
- batch applications reading 4-24
- configuration 1-8
- control information 4-6
- control interval 1-7
- controlling via Queue Options Maintenance screen 3-16
- creating 2-19
- data removed by EDIEOQR 4-53
- defining 5-6
- defining to CICS 2-22
- description 5-6
- direction 1-9
- disabled 3-22, 4-60
- disabling 1-9
- disposition B-2
- errors 3-34
- even-numbered 3-34
- explanation 1-4, 1-7

- formatting 2-19, 5-6
- GENTRAN:Realtime 3-34
- identification 1-9
- initializing for use with GENTRAN:Control 4-6
- loading from a sequential file 4-36
- locating problems in 3-34, 3-39
- maintenance 1-9
- number 1-9
- odd-numbered 3-34
- opening and closing 4-4, 4-5
- pointers and counts 5-6
- processing method 2-19, 5-6
- processing stalls 3-22
- read by batch programs 4-30
- reading even and odd numbered 4-4
- records in Checkpoint file 5-2
- records in Online Control file 5-4
- recreating 5-7
- see* Glossary
- setting characteristics 3-16
- setting up processing and flow 2-11
- size 1-9, 3-19
- source of input 2-11
- space allocation 2-19
- space requirements 5-7
- status information 1-4
- updating pointers 4-4, 4-5
- validating during system initialization 4-60
- viewing data before processing 3-44
- wrap-around processing 1-7
- wrap-around processing 1-9
- writing to even and odd numbered 4-5
- written to by batch applications 4-31
- written to by batch programs 4-36

Queue File Maintenance program - EDIEQMT 4-6

Queue File Maintenance program (EDIEQMT) 1-9

- initializing Queue files 5-6

Queue file records

- formatting application records 4-5
- writing 4-5

Queue file status 3-14

Queue files

- file description 5-6

Queue Options Data Display screen (EDIM307) **3-44–3-45**

Queue Options Debug Detail screen (EDIM306) **3-34–3-43**

Queue Options Debug Detail screen (EDIM306)
 for even-numbered Queue files 3-34

Queue Options Debug Detail screen (EDIM306)
 for odd-numbered Queue files 3-39

Queue Options Maintenance screen (EDIM303)
3-16–3-24
 and Online Scanner/Initiator 4-60
 Appl.Prog field 4-63
 Error User Exit Pgm field 4-56
 Exception Pgm field 4-53
 tutorial 2-26

Queue Read program (EDIRQRD)
 calling Central Multi-Queue Read subroutine
 (EDIRCMR) 4-4

Queue Read transaction (EDIR) 6-2

Queue Write program (EDIEOQR) 1-21

Queue Write program (EDIRQWR) 4-19
 calling Central Multi-Queue Write
 subroutine (EDIRCMW) 4-5

R

records
 written to a TSQ, limits 4-38

Remote Single-Queue Read subroutine
 (EDIERSR) 4-24
 accessing Queue files for Sample Queue
 Read program 4-30
 called by user program 1-23

Remote Single-Queue routines 1-9

Remote Single-Queue Write subroutine
 (EDIERSW) 4-31
 accessing Queue files for Sample Queue
 Write program 4-36
 called by batch application 1-30
 called by user program 1-22

requested operation 4-3
 multiple 4-3

return codes 3-30, 3-49
 Error 3-30, 3-49
 Normal 3-30, 3-49
 Severe Error 3-30, 3-49
 Warning 3-30, 3-49

Router - EDIR945 4-72

S

Sample Error Exit program (EDIEXIT2) 4-56

Sample Online Application program (EDIESOA)
 4-63
 and Appl.Prog field 4-63

Sample Queue Read program (EDIESQR) 4-30
 demonstrating Remote Single-Queue Read
 subroutine 4-24

Sample Queue Write program (EDIESQW) 4-36
 demonstrating Remote Single-Queue Write
 subroutine 4-31

scan
 frequency 3-8
 of document queues 1-13
 setting interval 3-10

scan interval
 too large 3-10
 too small 3-10

Scan Interval field 3-10
 System Options Maintenance screen 4-60

screens 3-1
 navigating 2-8

security 2-3
 password 2-3
 updating 2-4, 2-7

Separator Control file (EDIRSEP) 2-14, 2-15, 2-
 16, 3-52, 3-59, 3-62

Separator Driver - EDIR930 4-66

Separator Gateway - EDIR100 4-64

Separator Main Menu (EDIM934) **3-50–3-51**

Separator Monitor screen (EDIM938) **3-66–3-68**

Separator subsystem 1-5
 subfunctions available 2-13, 3-50

Separator Systems Options Maintenance screen
 key usage indicators 3-53

Separator Systems Options Maintenance screen
 (EDIM935) **3-52**

Separator Systems Options record
 displaying 2-14, 3-52
 updating 2-14, 3-52

separator, subelement
see Glossary

sequential files, creating 4-30

server
see Glossary

Severity Indicator Values
 Fatal Error 3-30, 3-49
 Informational 3-30, 3-49

Index

Severe Error 3-30, 3-49
Trace 3-30, 3-49
Warning 3-30, 3-49
source
 see Glossary
Source field 2-26, 3-14, 3-18
special character jump codes 3-4
Stall Limit field 3-22
stalls 3-10
 batch 1-13
 CICS 1-13
status
 enabling/disabling 3-18
 viewing 2-12, 3-25, 3-46
status code
 see Glossary
status control 1-2
Status field 2-10, 3-14, 3-18
subelement separator
 see Glossary
submitting JCL 6-2
subsystem, defined 3-2
SWAP 3-4, 3-5
system activity, monitoring 1-2
system control, CICS-based 1-4, 1-13
system image
 ID 1-14
 ID, default 1-14
 multiple 1-4, 1-14
system interruptions, detection 5-2
system maintenance 1-13
System Options Maintenance screen (EDIM301)
 3-8-3-11
 Error User Exit Pgm field 4-56
 Scan Interval field 4-60
System Status field 3-9
System Status Toggle program (EDIETOGL) 4-18
system status, Checkpoint file 5-2
system trace option 1-13

T

temporary storage queue
 see Glossary
 see TSQ
time interval
 see Glossary

trace facility 1-2, 1-13
 system status information 1-2
TRADACOMS Interchange Priority Lookup -
 EDIR933 4-70
transaction data
 fixed and variable length 1-7
Transaction ID
 EDIA 3-28
 EDIB 3-28
 EDII 3-28
 EDIR 3-28
 EDIT 3-28
translation system 1-4, 1-14
trigger level 2-11, 2-26, 3-15, 4-60
 and Queue file size 3-19
 document 1-13
Trigger Levels field 3-19
TSQ
 multiple 4-38
 record limits 4-38
 see Glossary
turnaround time
 see Glossary

U

Unit of Work 1-17
 components 1-17
 examples 1-18-1-23
 split to multiple TSQs 4-38
unwrap
 see Glossary
user exit program 1-2
user ID 2-3
 for background tasks 6-2
User-Defined Jump Code table 3-4
utility control cards 4-3

V

viewing
 entries in Monitor Header file 2-17, 3-66
 messages on Online Log Display screen 3-46
 messages on Online Log file 2-12
 Online Log file 3-25
 Queue file data before processing 3-44

Queue files in Online Control file 3-12
records used by interchange router programs
2-15, 3-59

X

X12 Interchange Priority Lookup - EDIR931 4-
68

