

GENTRAN:Server® for UNIX®

Extension for SAP® R/3™

Version 6.0

Sterling Commerce
An IBM Company

Copyright Notice

March 2002

© Copyright 2002

Sterling Commerce, Inc.

ALL RIGHTS RESERVED

WARNING: ANY UNAUTHORIZED DUPLICATION OF THIS DOCUMENTATION SHALL BE AN INFRINGEMENT OF COPYRIGHT.

Trade Secret Notice

This documentation, the software it describes, and the information and know-how they contain constitute the proprietary, confidential and valuable trade secret information of Sterling Commerce, Inc., its affiliated companies or its or their licensors, and may not be used for any unauthorized purpose, or disclosed to others without the prior written permission of the applicable Sterling Commerce entity. This documentation and the software that it describes have been provided pursuant to a license agreement that contains prohibitions against and/or restrictions on their copying, modification and use. Duplication, in whole or in part, if and when permitted, shall bear this notice and the Sterling Commerce, Inc. copyright notice. As and when provided to any governmental entity, government contractor or subcontractor subject to the FARs, this documentation is provided with RESTRICTED RIGHTS under Title 48 CFR 52.227-19. Further, as and when provided to any governmental entity, government contractor or subcontractor subject to DFARs, this documentation and the software it describes are provided pursuant to the customary Sterling Commerce license, as described in Title 48 CFR 227-7202 with respect to commercial software and commercial software documentation.

This documentation and the software which it describes are licensed either "AS IS" or with a limited warranty, as set forth in the applicable license agreement. Other than any limited warranties provided, NO OTHER WARRANTY IS EXPRESSED AND NONE SHALL BE IMPLIED, INCLUDING THE WARRANTIES OF MERCHANTABILITY AND FITNESS FOR USE OR FOR A PARTICULAR PURPOSE. The applicable Sterling Commerce entity reserves the right to revise this publication from time to time and to make changes in the content hereof without the obligation to notify any person or entity of such revisions or changes.

Product names mentioned herein may be trademarks and/or registered trademarks of their respective companies. GENTRAN and GENTRAN:Server are registered trademarks of Sterling Commerce, Inc.

Sterling Commerce, Inc.
4600 Lakehurst Court Dublin, OH 43016-2000 * 614/793-7000
© Copyright 2002—Sterling Commerce, Inc.



Table of Contents

About This Guide

▶ Overview	ii
▶ Document Conventions	v
▶ How to Get Help	vii

Extension Processing

▶ Introduction	1-2
▶ Inbound Processing	1-3
▶ Outbound Processing	1-6

Extension Triggering

▶ Overview	2-2
------------------	-----

Triggering Between SAP and GENTRAN:Server

▶ Outbound File-Based Triggering with NFS	2-3
▶ Outbound File-Based Triggering with Remote Copy	2-5
▶ Outbound ALE-Based IDoc Triggering	2-7
▶ Inbound SAP Triggering	2-9

SAP Connectivity Configuration

▶ How to Configure for NFS in SAP	2-11
▶ How to Configure for Remote Copy in SAP	2-16
▶ How to Use Register Mode to Define an ALE Environment	2-21

SAP Port Configuration

▶ How to Configure an RFC Port Definition	2-26
▶ How to Configure an ALE Port Definition	2-33

File-Based Triggering

▶ How to Configure Inbound File-Based Triggering	2-37
▶ How to Configure Outbound File-Based Triggering	2-39

Configuring Inbound Extension Processing

Overview

▶ Introduction	3-3
▶ The Flow of Work	3-4
▶ How to Create the Supporting Files	3-6

Generating FA Status Messages

- ▶ Overview3-7
- ▶ How to Configure for FA Status Messages3-8

Naming the Process Flow

- ▶ Flow Identification Dialog Box3-10
- ▶ How to Name and Describe the Flow3-12

Creating an Inbound SAP Flow

- ▶ Overview3-14
- ▶ Source Agent Dialog Box3-16
- ▶ How to Set Up the Source Agent3-19
- ▶ Processing Agent Dialog Box3-22
- ▶ Translation Options Dialog Box3-25
- ▶ How to Set Up the Processing Agent3-27
- ▶ Delivery Agent Dialog Box3-29
- ▶ How to Set Up the Delivery Agent3-31

Completing a Flow

- ▶ Overview3-34
- ▶ Error Handling Dialog Box3-35
- ▶ How to Set Up Error Handling Instructions3-37
- ▶ Trading Partner Records Dialog Box3-40
- ▶ How to Add Trading Partnerships to the Flow3-42

Configuring an Inbound Route to SAP

- ▶ Overview3-44
- ▶ How to Create an Inbound Route (to SAP)3-51

Configuring Outbound Extension Processing**Overview**

- ▶ Introduction4-3
- ▶ The Flow of Work4-4
- ▶ How to Create the Supporting Files4-6

Naming the Process Flow

- ▶ Flow Identification Dialog Box4-7
- ▶ How to Name and Describe the Flow4-9

Creating an Outbound SAP Flow

- ▶ Overview4-11
- ▶ Source Agent Dialog Box4-13
- ▶ How to Set Up the Source Agent4-16
- ▶ Processing Agent Dialog Box4-18
- ▶ How to Set Up the Processing Agent4-20
- ▶ Delivery Agent Dialog Box4-21

- ▶ Translation Options Dialog Box 4-25
- ▶ How to Set Up the Delivery Agent 4-27

Completing a Flow

- ▶ Overview 4-31
- ▶ Error Handling Dialog Box 4-32
- ▶ How to Set Up Error Handling Instructions 4-34
- ▶ Trading Partner Records Dialog Box 4-37
- ▶ How to Add Trading Partnerships to the Flow 4-39

Configuring an Outbound Route for SAP

- ▶ Overview 4-41
- ▶ How to Create an Outbound Route (From SAP) 4-47

Creating an Outbound Trading Partner Cross Reference

- ▶ Overview 4-48
- ▶ How to Create a Trading Partner Cross Reference 4-51

Configuring Inbound and Outbound Extension Processing

- ▶ Overview 5-2
- ▶ The Flow of Work 5-3
- ▶ How to Create an Inbound and Outbound Route 5-5
- ▶ Creating a Trading Partner Cross Reference 5-7
- ▶ How to Create a Trading Partner Cross Reference 5-10

Configuring for Delayed Enveloping

- ▶ Delayed Enveloping 6-2
- ▶ Flow of Work 6-3
- ▶ How to Create Supporting Directories and Scripts 6-5
- ▶ How to Create the Translation Flow 6-6
- ▶ How to Create the Delayed Enveloping Flow 6-8
- ▶ Outbound Delayed Enveloping with Inbound FA 6-11

Supported SAP Status Codes

- ▶ SAP Status Codes A-2

SAP Partner Keys

- ▶ Partner Keys for SAP R/3 IDoc Version 2.x B-2
- ▶ Partner Keys for SAP R/3 IDoc Version 3.x B-3
- ▶ Partner Keys for SAP R/3 IDoc Version 4.x B-4

Status Messaging Using SYSTAT01 IDoc

- ▶ Overview C-2

- ▶ Configuring a Logical System for GENTRAN:Server C-3
- ▶ Assigning the Process Task STA1 to ALE C-7
- ▶ Configuring the GENTRAN:Server Logical System Partner Profile C-12

SAP Database Design

- ▶ SAP Route Configuration Table (Route) D-2
- ▶ Inbound TP Cross Reference (INBNDTP) D-8
- ▶ Outbound TP Cross Reference (OutboundTP_tb) D-9
- ▶ Dynamic Tables D-11
- ▶ Loading and Unloading SAP Database Tables D-13

User-Defined Status Messages

- ▶ Overview E-2
- ▶ Creating the Status File E-3
- ▶ Using the Status File in buildstat E-5

Utilities and Tools

- ▶ Introduction F-2

GENTRAN:Server Utilities

- ▶ buildstat F-3
- ▶ clearstat F-5
- ▶ deliveridoc F-6
- ▶ deliver_idoc_files.sh F-7
- ▶ dumpidoc F-8
- ▶ exterror F-9
- ▶ finishidoc F-10
- ▶ idoc2app.sh and idoc2ddf.sh F-11
- ▶ queueidoc F-12
- ▶ receiveidoc.sh F-13
- ▶ sapops F-14
- ▶ saproute F-15
- ▶ sortidoc F-16
- ▶ svr_enq_files.sh F-17
- ▶ script/sapstat.scr F-18

SAP Utilities

- ▶ aleclient F-19
- ▶ aleserver F-20
- ▶ rcprfcexec.sh F-21
- ▶ rfcexec F-22
- ▶ sc_rsh F-23
- ▶ startRFC F-24

idoc2app.sh and idoc2ddf.sh Utilities

- ▶ Using the idoc2app.sh and idoc2ddf Utilities G-2
- ▶ Reading Attributes from idoc2app.sh Output Files G-4
- ▶ Identifying and Creating a Looping Structure G-6

Index

About This Guide

Contents

▶ Overview	ii
▶ Document Conventions	v
▶ How to Get Help	vii

Overview

Introduction

Sterling Commerce's GENTRAN:Server Extension for SAP® R/3™ is a comprehensive, "off-the-shelf" extension for the receipt and transmission of electronic data interchange (EDI) transactions with SAP application software.

Who should use this guide

This guide is intended for users who want to automate delivery of intermediate documents (IDocs) to an SAP system and receipt of outbound IDocs from an SAP system. This guide assumes that users are familiar with the SAP application and SAP terminology. To set up and fully utilize the extension's capabilities, users should also be familiar with the following:

- UNIX operating system
- UNIX scripting facilities
- EDI and SAP processing environment

Note

If you want to create more complex flows than the PCM Wizard allows, please see the *GENTRAN:Server Dataflow Administration Guide* for instructions or call the Professional Services of Sterling Commerce to arrange for an onsite consultant visit.

About this guide

This guide leads you through the configuration of the GENTRAN:Server Extension for SAP. It explains extension configuration and introduces you to GENTRAN:Server Extension for SAP R/3 concepts. This guide contains the following parts:

Chapter	Contents
Extension Processing	Overview information about inbound and outbound processing.
Extension Triggering	Procedures for configuring SAP connectivity and extension triggering.
Configuring Inbound Extension Processing	Instructions for configuring the inbound extension process for connecting to SAP. (Continued on next page)

(Contd) Chapter	Contents
Configuring Outbound Extension Processing	Instructions for configuring the outbound extension process for transmitting data from SAP.
Configuring Both Inbound and Outbound Extension Processing	Instructions for configuring both an inbound and outbound process for connecting to SAP.
Configuring for Delayed Enveloping	Instructions for configuring data translation and enveloping as two separate events.
Appendix A, Supported SAP Status Codes	List of status codes that the extension uses during outbound processing of IDocs that SAP created.
Appendix B, SAP Partner Keys	List of fields from the EDI_DC control record in SAP R/3 version 2.x, 3.x, and 4.x.
Appendix C, Status Messaging Using SYSTAT01 IDoc	Procedures required to implement ALE status messaging.
Appendix D, SAP database design	Explanatory information about the SAP databases and how they are configured and used in SAP.
Appendix E, User-Defined Status Messages	Instructions for creating message status files and using message status files in buildstat.
Appendix F, Utilities and Tools	Description of the main programs and scripts used to configure your SAP Extension.
Appendix G, The IDOC2APP Utility	Description of the IDOC2APP utility and instructions for converting IDocs to application descriptions and file definitions (.ddfs).

(Continued on next page)

Supplemental publications

The following table lists supplemental publications for the SAP extension.

If you need more information regarding...	Then see...
GENTRAN:Server for UNIX	the <i>GENTRAN:Server Data Flow Administration Guide</i> .
upgrading to GENTRAN:Server® Version 6.0	the <i>GENTRAN:Server for UNIX Upgrade and Conversion Guide</i> .
the UNIX operating system	your UNIX manuals.
SAP	<ul style="list-style-type: none"> ▶ the <i>SAP System R/3 EDI Interface Configuration Manual</i>. ▶ the <i>WF-EDI Intermediate Document-Triggering Manual</i>. <p>Note This document includes the SAP configuration requirements needed to enable GENTRAN:Server to send IDoc files to the SAP system.</p>
Processing within the SAP system	the <i>EDI Interface - Basis SAP</i> document.

SAP R/3 information

The SAP R/3 screen captures used in this manual are from SAP Release 3.x for SAP. Screens may appear different in your release.

If you have any questions on the SAP R/3 installation configuration, please call your SAP support and not the Sterling Commerce support line.

Document Conventions

Introduction Conventions used in this guide are described in this topic.

Typographic conventions This table describes the typographic conventions used in this guide.

Convention	Use
Italics	This typeface is used for titles of other manuals and documents, names of files and file extensions, and to emphasize important information. Example <i>GENTRAN:Server Application Integration User's Guide</i>
Bold	Bold type is used for program names, key terms the first time they are used within a chapter, and entries you are to make on-screen. Example A password is a set of characters a user must enter to gain access to a system.

Symbols used within syntax statements This table describes symbols used within syntax statements.

Symbol	Use
< >	Substitute a value for any term that appears within angle brackets. Do not enter angle brackets unless specifically told to do so. Example rm <filename> means that you should type the name of the file you want to delete. <i>(Continued on next page)</i>

(Contd) Symbol	Use
{ }	<p>Braces indicate a required part of a statement. Do not enter the braces.</p> <p>Example {f <filename>} means you must enter the f parameter followed by a filename.</p>
[]	<p>Brackets indicate an optional part of a statement. Do not enter the brackets.</p> <p>Example [f <filename>] means you could type the f parameter followed by a filename, but you are not required to do so.</p>
...	<p>An ellipse indicates that the immediately preceding item can be repeated indefinitely. Do not enter the ellipse.</p> <p>Example -e... means that you can repeat -e with other values.</p>
()	<p>Parentheses should be entered as shown. They are part of the syntax of a statement and are not special symbols.</p> <p>Example (n) means that you should type a number enclosed by parentheses.</p>
under_score	<p>An underscore bridges a multi-word term.</p>

How to Get Help

Introduction This topic explains how to contact Sterling Commerce Product Support if you need assistance with GENTRAN:Server.

Scope of Support Services Sterling Commerce Product Support can provide assistance and information for the following:

- ▶ Installing GENTRAN:Server
- ▶ GENTRAN:Server product questions
- ▶ Software revisions and upgrades
- ▶ Implementing a specific feature
- ▶ How to use GENTRAN:Server
- ▶ The status of your support call
- ▶ Requests for product enhancements

Unfortunately, Sterling Commerce Product Support cannot assist you with problems involving the following, but we may be able to suggest a next step or another vendor to call:

- ▶ Your hardware
- ▶ Your operating system or other system software
- ▶ Your application or user-written programs
- ▶ Software not developed by Sterling Commerce
- ▶ Scripts written by Sterling Commerce consultants or service partners

Try this first Before you call Sterling Commerce Product Support, use your online software manuals to locate the section that documents the program or feature where you are having problems. The documentation may explain the software's behavior or give you insight to help you solve the problem.

Consult the *GENTRAN:Server Maintenance and Troubleshooting Guide* to learn if your specific problem has been addressed.

(Continued on next page)

Copy this page

Please feel free to make a copy of this page to enable you to contact support quickly and with complete information for the Customer Support Representative.

Necessary information

Be ready to provide this information when you call Product Support.

Your name
Your company name
Your telephone number
Your GENTRAN:Server version number
Your GENTRAN:Server product level and platform
Any software add-ons to your GENTRAN:Server system
A detailed description of the problem

(Continued on next page)

The sequence of steps that led to the problem

What actions you have taken to try to diagnose or resolve the problem

How to contact support

To determine how to contact support for your geographical location, go to the Sterling Commerce home page (www.sterlingcommerce.com) and then go to **Customer Support** for GENTRAN.



Extension Processing

Contents

- ▶ Introduction 2
 - ▶ Inbound Processing 3
 - ▶ Outbound Processing 6
-

Introduction

Purpose of extension

The GENTRAN:Server Extension for SAP R/3 enables data to pass between the GENTRAN:Server and SAP systems in a bidirectional manner. You use the extension to deliver inbound intermediate documents (IDocs) to an SAP system and to receive outbound IDocs from an SAP system.

Additional features of the extension software include the following:

- Ability to send status messages for outbound IDocs to SAP .
- A utility named *idoc2app* that reformats IDoc layouts extracted from an SAP system into a format that you can use to create an application description in GENTRAN:Server's Visual Mapper.
- A utility named *idoc2ddf* that reformats IDoc layouts into file definitions (.ddf files) that GENTRAN:Server's Application Integration mapper can use.
- Application Linking and Enabling (ALE) to allow passing of SAP IDocs to and from SAP through an Application Programming Interface (API) as an alternative to Network File System (NFS) or Remote Copy (RCP).

Inbound communication

The extension creates a file of IDocs, uses NFS, RCP, or ALE to transfer the file to the SAP system, and then triggers SAP to start processing.

Outbound communication

SAP creates outbound IDoc data by placing the data into a file. It invokes an extension-defined tool to signal to the extension that data is ready for processing.

SAP communications options

Installation of the extension offers a number of available communications options. You can configure:

- SAP hosts
- SAP ports on one or more SAP hosts
- SAP clients on one or more SAP hosts

You can configure the extension to transfer IDocs to SAP with:

- NFS
 - RCP
 - ALE
-

Inbound Processing

Introduction An inbound processing flow (standard-to-SAP or application-to-SAP) prepares and routes files to SAP. The type of processing depends on the type of input file (standard or application).

Intelligent agents For standard-to-SAP processing, the SAP extension's inbound flow uses the following intelligent agents:

- ▶ SEI
- ▶ E2I
- ▶ SID

Reference

See the *GENTRAN: Server Data Flow Administration Guide* for an explanation of intelligent agents and how they work.

Inbound standard-to-SAP process flow diagram

This diagram illustrates the inbound standard-to-SAP processing flow.

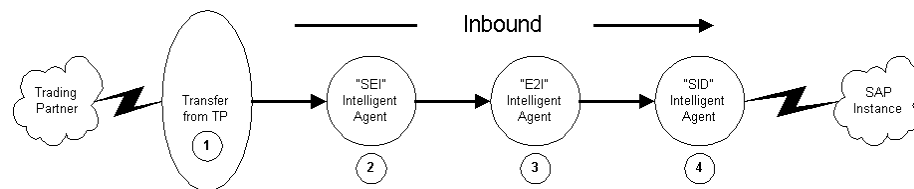

(Continued on next page)

**Inbound
standard-to-SAP
process flow
description**

This table describes how inbound EDI standard-to-SAP data is processed.

Stage	Description
1	The communications gateway detects a new document file and routes the document file to the SEI intelligent agent.
2	The SEI intelligent agent: <ul style="list-style-type: none"> ▶ Scans the document to ensure it is in an understandable EDI standard format ▶ Looks up the GENTRAN:Server Trading Partnership code ▶ Builds the document reference number ▶ Uses the file name format <TPCODE>.<MBID>.<UNIQID> to rename the document file and routes the document file to the E2I intelligent agent.
3	The E2I intelligent agent: <ul style="list-style-type: none"> ▶ Calls the translation script to translate the document file into a non-sequenced IDoc format ▶ routes the file to the SID intelligent agent.
4	The SID intelligent agent: <ul style="list-style-type: none"> ▶ Completes the control fields in the IDoc that are route dependent ▶ Sends the document file to SAP.

(Continued on next page)

Inbound application-to-SAP processing

For application-to-SAP processing, the SAP extension's inbound flow uses the following intelligent agents:

- ▶ SAI
- ▶ A2I
- ▶ SID

Inbound application-to-SAP process flow diagram

This diagram illustrates the inbound application-to-SAP processing flow.

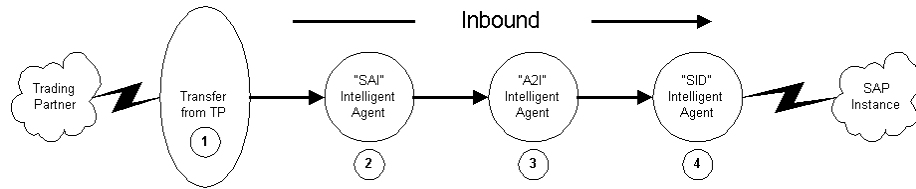

Inbound application-to-SAP process flow description

This table describes how inbound application-to-SAP data is processed.

Stage	Description
1	The communications gateway detects a new document file and routes the document file to the SAI intelligent agent.
2	The SAI intelligent agent: <ul style="list-style-type: none"> ▶ Scans the document for an application file ▶ Extracts the trading partner data and the GENTRAN:Server Trading Partnership code ▶ Builds a document reference number ▶ Uses the file name format <TPCODE>.<MBAGID>.<UNIQID> to rename the document file and routes the document file to the A2I intelligent agent.
3	The A2I intelligent agent: <ul style="list-style-type: none"> ▶ Calls the translation script to translate the document file into a non-sequenced IDoc format ▶ Routes the document file to the SID intelligent agent with the file name <TPCODE>.<MBAGID>.<UNIQID>.
4	The SID intelligent agent: <ul style="list-style-type: none"> ▶ Completes the control fields in the IDoc that are route dependent ▶ sends the document file to SAP with the file name <TPCODE>.<MBAGID>.<UNIQID>.



Outbound Processing

Introduction An outbound processing flow prepares and routes document files coming from the SAP system.

Intelligent agents The extension's outbound element consists of the following outbound intelligent agents:

- ▶ SIR
- ▶ SIA
- ▶ I2E

Reference

See the *GENTRAN: Server Data Flow Administration Guide* for an explanation of intelligent agents and how they work.

Outbound from SAP process flow diagram

This diagram illustrates the outbound SAP to standard processing flow.

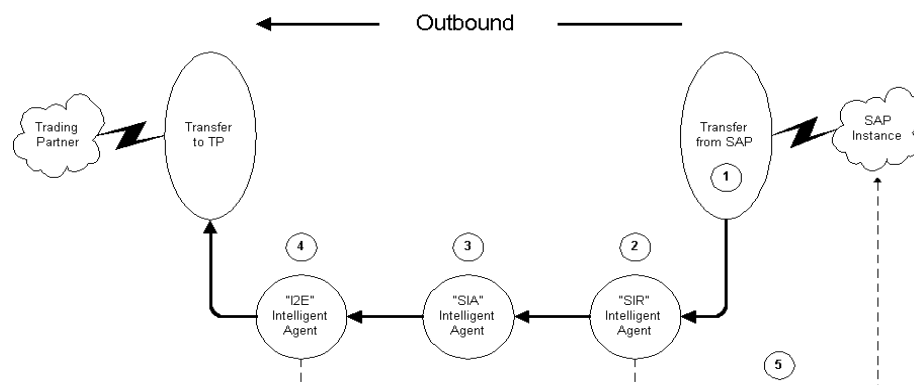

(Continued on next page)

Outbound SAP process flow

This table describes how outbound SAP data is processed to EDI standard data so it can be sent to a trading partner.

Stage	Description
1	The communications gateway detects a new document file from SAP and routes the new document file to the SIR intelligent agent.
2	The SIR intelligent agent: <ul style="list-style-type: none"> ▶ Receives the document file ▶ Uses the Trading Partner Cross Reference database to split the IDoc data into individual files by Trading Partnership code ▶ Sends status messages back to SAP ▶ Uses the file name format <TPCODE>.<MBAGID>.<UNIQUID> to rename a file for each Trading Partner and routes it to the SIA intelligent agent.
3	For each Trading Partner file, the SIA intelligent agent: <ul style="list-style-type: none"> ▶ Validates the IDoc information ▶ Builds the document reference number ▶ Sends the document file to the I2E intelligent agent.
4	For each Trading Partner file, the I2E intelligent agent: <ul style="list-style-type: none"> ▶ Calls the translation script to translate the IDoc document file into an EDI standard format ▶ Sends status messages back to SAP ▶ Routes the document file to the trading partner.
5	The SIR and I2E intelligent agents pass status messages to SAP.

Extension Triggering

Contents	▶ Overview	2
	Triggering Between SAP and GENTRAN:Server	
	▶ Outbound File-Based Triggering with NFS	3
	▶ Outbound File-Based Triggering with Remote Copy	5
	▶ Outbound ALE-Based IDoc Triggering	7
	▶ Inbound SAP Triggering	9
	SAP Connectivity Configuration	
	▶ How to Configure for NFS in SAP	11
	▶ How to Configure for Remote Copy in SAP	16
	▶ How to Use Register Mode to Define an ALE Environment	21
	SAP Port Configuration	
	▶ How to Configure an RFC Port Definition	26
	▶ How to Configure an ALE Port Definition	34
	File-Based Triggering	
	▶ How to Configure Inbound File-Based Triggering	38
	▶ How to Configure Outbound File-Based Triggering	40

Overview

Introduction

The GENTRAN:Server Extension for SAP R/3 enables data to pass between the GENTRAN:Server and SAP systems in a bidirectional manner.

Inbound Communication

The extension creates a file of IDocs, transfers the file to the SAP system using NFS, RCP, or ALE, then triggers SAP to start processing.

Outbound Communication

SAP creates outbound intermediate document (IDoc) data by placing the data into a file. It invokes an extension-defined tool to signal to the extension that data is ready for processing.

SAP R/3 information

The SAP R/3 screen captures used in this manual are from Release 4.x for SAP. Screens may appear different in your release.

If you have any questions on the SAP R/3 installation configuration, please call your SAP support and not the Sterling Commerce support line.

Triggering Between SAP and GENTRAN:Server

Outbound File-Based Triggering with NFS

- Overview** While the extension eliminates the need to use NFS and multiple mounts for triggering, you might want to set up file-based triggering with NFS if you are using:
- ▶ Three or fewer hosts/ports, or
 - ▶ NFS, and managing many mount points is preferable to you.

NFS-based triggering diagram

This diagram illustrates NFS-based trigger processing.

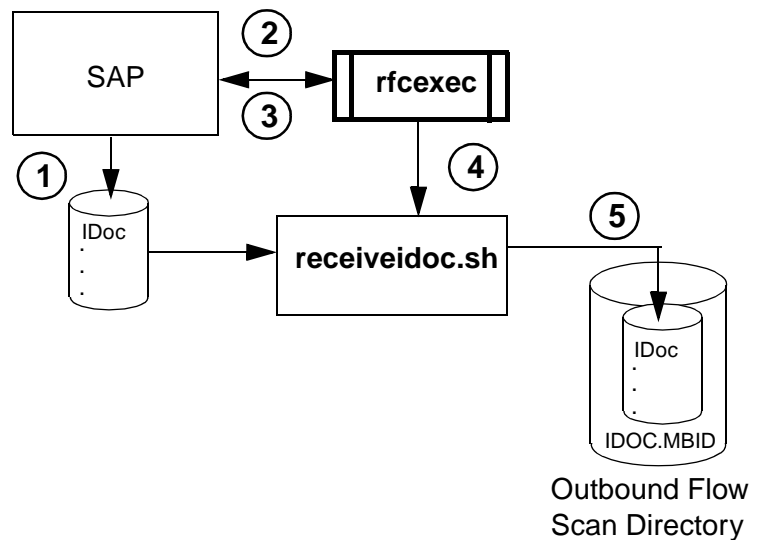

(Continued on next page)

How NFS-based triggering works

This table describes the NFS-based triggering process.

Stage	Description
1	SAP writes IDoc data into a shared directory as defined by the SAP logical port.
2	SAP triggers the SAP supplied program, rfcexec , via the RFC destination defined in SAP.
3	The rfcexec program contacts SAP to determine the EDI trigger program receiveidoc.sh defined in the SAP logical port definition.
4	The rfcexec program invokes the receiveidoc.sh trigger program to begin processing the outbound IDoc data.
5	The receiveidoc.sh trigger program routes the incoming IDoc file to the Outbound Flow Scan Queue. The IDoc file is removed from SAP's shared directory and is named IDoc.MBID when placed in the Outbound Flow Scan Directory.

Outbound File-Based Triggering with Remote Copy

Introduction

File-based triggering with remote copy eliminates the need to use multiple mounts with NFS. This method is convenient when you have many ports and hosts.

Trigger processing in a non-NFS environment

This diagram illustrates trigger processing in a non-NFS environment.

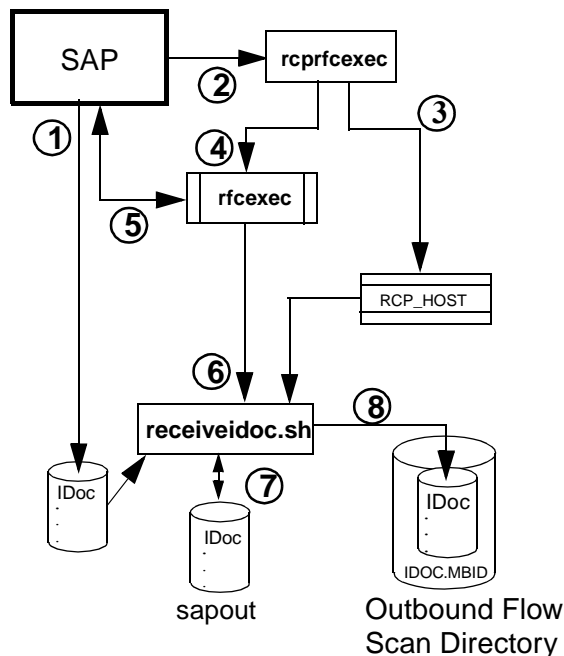

How the non-NFS trigger process works

This table describes trigger processing in a non-NFS environment.

Stage	Description
1	SAP writes IDoc data into the directory defined by the SAP logical port for rcprfcexec.sh .
2	SAP triggers rcprfcexec.sh via the RFC destination in SAP.
3	The rcprfcexec.sh program determines the calling SAP application server (host name) saves the value of the calling host in an environment variable, RCP_HOST.

(Continued on next page)

(Contd) Stage	Description
4	The rcprfcexec.sh program invokes the SAP supplied program rfcexec .
5	The rfcexec program contacts SAP to determine the EDI trigger program defined in the logical port definition.
6	The rfcexec program invokes receiveidoc.sh to begin processing the outbound IDoc data.
7	The receiveidoc.sh program makes a remote copy, renames the file to IDoc.MBID, and moves the IDoc file from the remote SAP system to the local host's sapout directory. The process removes the remote file from the SAP system.
8	<p>The receiveidoc.sh program routes the IDoc file (IDoc.MBID) from the sapout directory to the appropriate Outbound Flow Scan Directory.</p> <p>Note The trigger program receiveidoc.sh has the fully-qualified pathname to the file to be processed (presented as a command-line argument).</p> <p>The receiveidoc.sh program uses the value from RCP_HOST from its environment, along with the file name specified on the command line, to retrieve the file to be processed without requiring NFS.</p>

Outbound ALE-Based IDoc Triggering

Introduction Application Linking and Enabling (ALE)-based IDoc transfer enables SAP to transfer IDocs to the extension program **aleserver** through ALE Application Program Interface (API).

receiveidoc.sh program The **aleserver** program invokes the **receiveidoc.sh** program to begin processing outbound IDoc data.

ALE modes ALE can operate in two modes:

- ▶ *Register mode*—In this mode the system connects to the SAP extension based on the assumption that the processes are up and running. The register mode is the preferred mode for normal use.

Note

Register mode does not require intermediate configuration.

- ▶ *Start mode*—In this mode the system verifies that the processes operate correctly. The start mode is also used only for debugging and testing purposes. This mode works like the RFC method. It triggers the ALE server program when outbound documents are sent.

(Continued on next page)

Diagram of outbound processing

This diagram illustrates the outbound processing in an ALE-based environment.

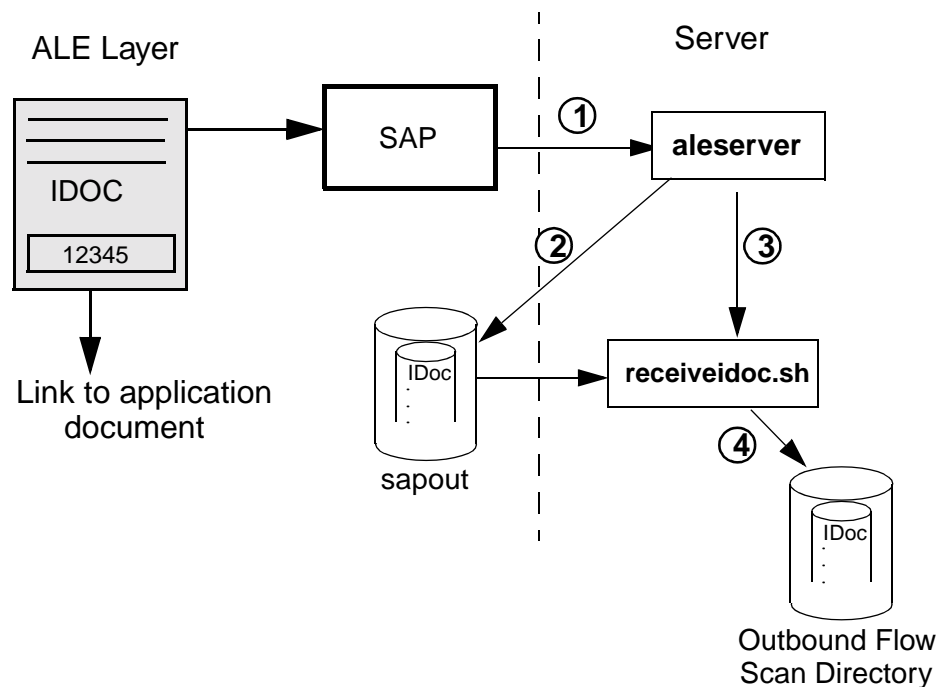

How the ALE-based trigger process works

This table describes trigger processing in a ALE-based environment.

Stage	Description
1	SAP triggers the registered ALE server via a transactional RFC call from the RFC destination in SAP.
2	ALE server writes the IDoc file out to the sapout directory in the form <GWHOST>.<GWSVC>.<TRANS_ID>.
3	ALE server invokes the EDI trigger program receiveidoc.sh .
4	The program receiveidoc.sh routes the IDoc file from the sapout directory to the Outbound Flow Scan Directory.

Inbound SAP Triggering

aleclient program The **aleclient** sends IDoc data to the SAP application. After it is called by the **deliveridoc** program, the **aleclient** goes to the SAP configuration database to gather routing parameters, transfers the IDoc data, and then invokes a triggering program.

aleclient diagram The following diagram shows inbound processing using the **aleclient** program.

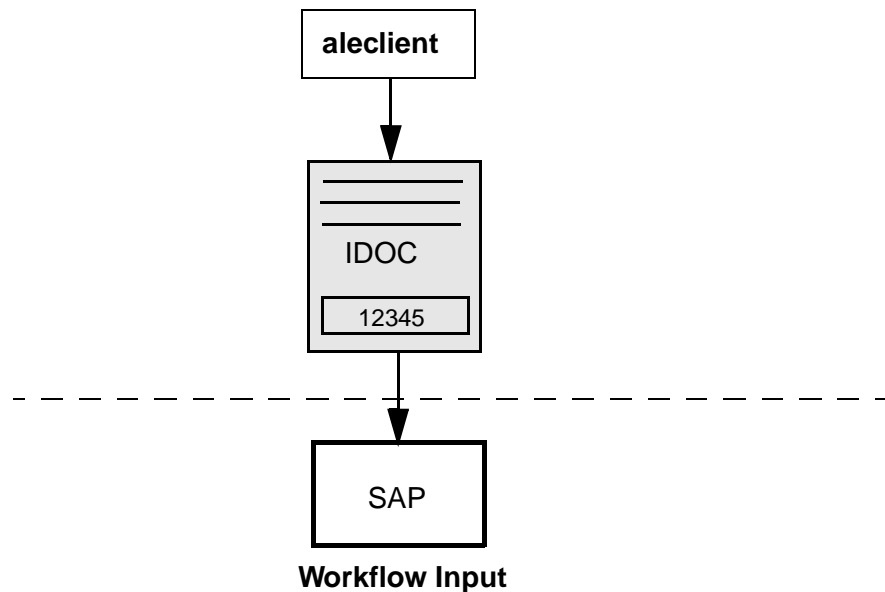

startRFC parameters The **aleserver** and **aleclient** programs use **startRFC** parameters to make the connection to the SAP system and send IDocs to SAP.

Reference

See [startRFC](#) in Appendix F for the list of parameters defined for **startRFC**.

aleserver command format This is a sample command line.

```
aleserver -[<SAP_version>] -a [<program_ID>]\
-g [<SAP_gateway>] -x [<SAP_gateway_service>] -v[123]
```

(Continued on next page)

**aleserver
parameters**

This table lists the parameters defined for the **aleserver** command.

Utility Parameter	Flag	Parameter (example)	Description	Your Value
program_ID	-a	hssfds05. aleserver	Identifies the Program ID to register this aleserver under (must match the Program ID field in step 7 of SAP ALE Server Configuration).	
sap_gateway	-g	hwll39	Identifies the gateway server. Steps to Locate 1. Use SE38. 2. Enter the report name rsparam . 3. Select Execute . 4. Select System → List → Find String . 5. Enter rdisp/sna_g . 6. Position the cursor by double-clicking the first line. 7. Find the gateway server in the line rdisp/sna_gateway . Scroll right.	
sap_gateway_service	-x	sapgw95	Identifies gateway service as in / etc./services1. Steps to Locate 1. Use SE38. 2. Enter the report name rsparam . 3. Select Execute . 4. Select System → List → Find String . 5. Enter rdisp/sna_g . 6. Position the cursor by double-clicking the first line. 7. Find the gateway server in the line rdisp_gw_service . Scroll right.	

SAP Connectivity Configuration

How to Configure for NFS in SAP

Introduction The SAP Configuration for NFS enables you to set up the RFC Destination for NFS using a SAP-to-GENTRAN:Server triggering method.

Procedure Use this procedure to set up RFC destination for NFS in SAP.

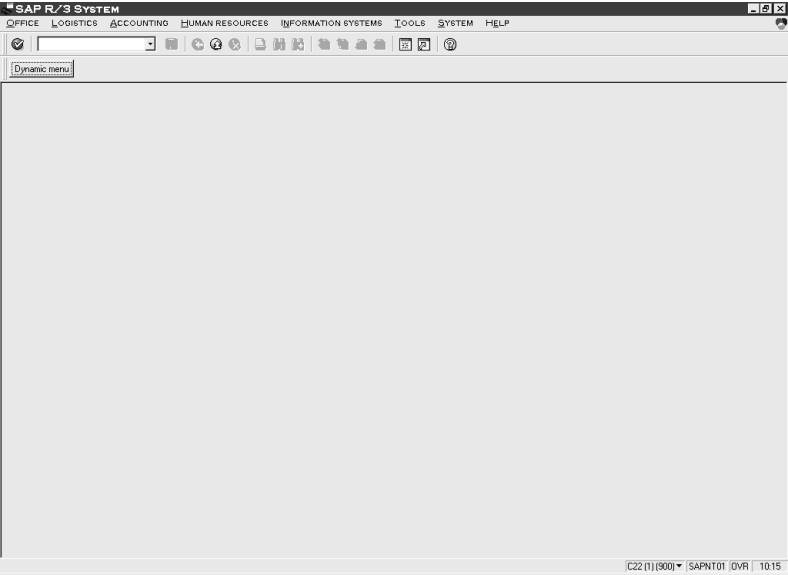
Step	Action
1	<p>Log on to your SAP system.</p> <p>System Response The system displays the SAP R/3 System dialog box.</p>  <p>(Continued on next page)</p>

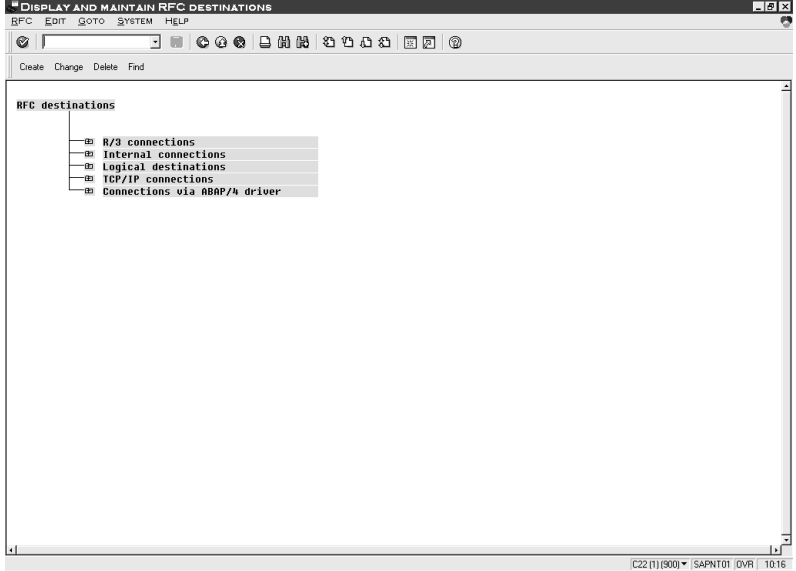
(Contd) Step	Action
2	<p>In the SAP R/3 System dialog box type SM59 transaction in the menu and click the check (✓) box.</p> <p>System Response The system displays the Display and Maintain RFC Destinations dialog box.</p>  <p style="text-align: right; color: red;">(Continued on next page)</p>

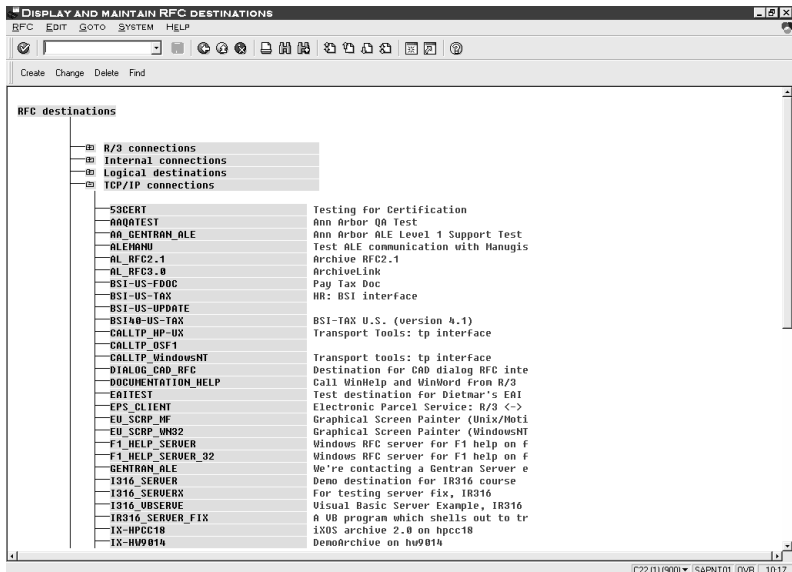
(Contd) Step	Action
3	<p>Click on TCP/IP connections in the Display and Maintain RFC Destinations dialog box.</p> <p>System Response The folder expands to a bigger tree containing all the TCP/IP connections.</p>  <p>The screenshot shows a window titled "DISPLAY AND MAINTAIN RFC DESTINATIONS". The main area displays a tree structure under "RFC destinations". The "TCP/IP connections" folder is expanded, revealing a list of destinations with their descriptions:</p> <ul style="list-style-type: none"> 53CERT: Testing for Certification ARAQTEST: Ann Arbor QA Test AR_GENTRAN_ALE: Ann Arbor ALE Level 1 Support Test ALEMANU: Test ALE communication with Manugis AL RFC2.1: Archive RFC2.1 AL RFC3.0: Archivelink BSI-US-FDOC: Pay Tax Doc BSI-US-TAX: HR: BSI interface BSI-US-UPDATE: BSI-TAX U.S. (version 4.1) BSI40-US-TAX: BSI-TAX U.S. (version 4.1) CALLTP_HP_US: Transport Tools: tp interface CALLTP_OSF1: Transport tools: tp interface CALLTP_WindowsNT: Transport tools: tp interface DIALOG_CAD_RFC: Destination for CAD dialog RFC inte DOCUMENTATION_HELP: Call WinHelp and WinWord from R/3 ERATEST: Test destination for Dietmar's ERI EPS_CLIENT: Electronic Parcel Service: R/3 <-> EU_SCRP_HF: Graphical Screen Painter (Unix/Moti EU_SCRP_WMS2: Graphical Screen Painter (WindowsNT F1_HELP_SERVER: Windows RFC server for F1 help on f F1_HELP_SERVER_32: Windows RFC server for F1 help on f GENTRAN_ALE: We're contacting a Gentrans Server e I316_SERVER: Demo destination for IR316 course I316_SERVERX: For testing server FIX, IR316 I316_USERVEE: Usual Basic Server Example, IR316 IR316_SERVER_FIX: A UB program which shells out to tr IX-HPCC18: IXOS archive 2.0 on hpcc18 IX-HU9014: DemoArchive on hu9014

(Continued on next page)

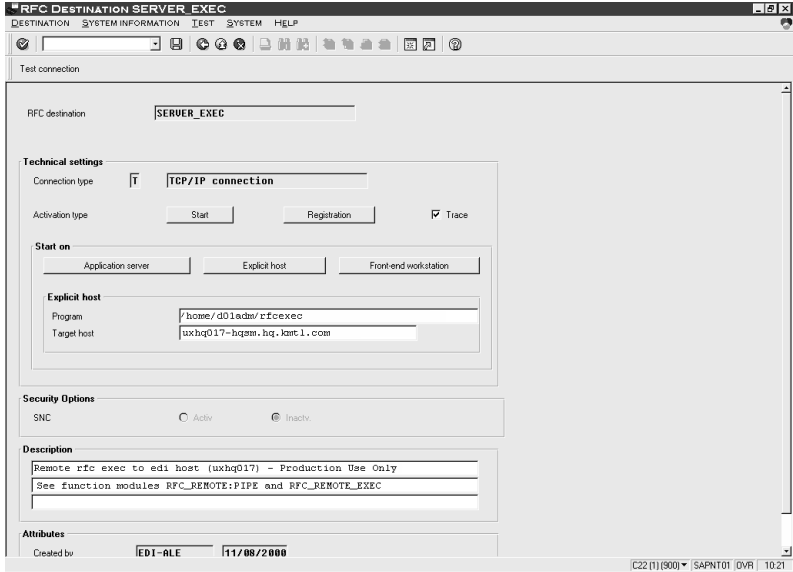

(Contd) Step	Action
4	<p>Double-click SERVER_EXEC in the TCP/IP list to get to the Control Form.</p> <p>Note SERVER_EXEC is the name used in this example. Your GENTRAN:Server name could be different.</p> <p>System Response The system displays the RFC Destination SERVER_EXEC dialog box.</p> 
5	Click Explicit host .
6	<p>In the RFC Destination SERVER_EXEC dialog box make sure the following fields are filled in with the correct values:</p> <ul style="list-style-type: none"> ▶ Connection Type = T ▶ Activation Type = Click Start ▶ Program = The path to the GENTRAN:Server Extension for SAP supplied rfcexec program. ▶ Target Machine = The Host name of your EDI system. ▶ Description = Whatever meets your implementation needs. <p>Note Trace can be used during configuration to help debug the system. When the system is configured and running correctly you can clear the Trace check box.</p> <p style="text-align: right; color: red;">(Continued on next page)</p>

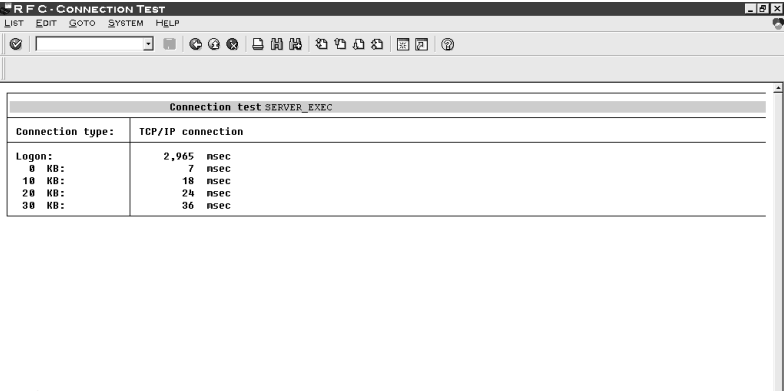
(Contd) Step	Action														
7	Save the configuration information in RFC Destination SERVER_EXEC dialog box.														
8	<p>Click Test connection to test the connection and make sure this configuration is correct.</p> <p>System Response The system displays the RFC Connection Test dialog box containing connection information. If the connection is unsuccessful, you receive an unable to connect error message.</p>  <table border="1" data-bbox="625 819 1388 919"> <thead> <tr> <th colspan="2">Connection test SERVER_EXEC</th> </tr> <tr> <th>Connection type:</th> <th>TCP/IP connection</th> </tr> </thead> <tbody> <tr> <td>Logon:</td> <td>2,965 nsec</td> </tr> <tr> <td>0 KB:</td> <td>7 nsec</td> </tr> <tr> <td>10 KB:</td> <td>18 nsec</td> </tr> <tr> <td>20 KB:</td> <td>24 nsec</td> </tr> <tr> <td>30 KB:</td> <td>36 nsec</td> </tr> </tbody> </table>	Connection test SERVER_EXEC		Connection type:	TCP/IP connection	Logon:	2,965 nsec	0 KB:	7 nsec	10 KB:	18 nsec	20 KB:	24 nsec	30 KB:	36 nsec
Connection test SERVER_EXEC															
Connection type:	TCP/IP connection														
Logon:	2,965 nsec														
0 KB:	7 nsec														
10 KB:	18 nsec														
20 KB:	24 nsec														
30 KB:	36 nsec														
9	<p>Does the dialog box show the LOGON timing information?</p> <ul style="list-style-type: none"> ▶ If YES, the RFC Destination is fully operational. ▶ If NO, verify the information that you entered in this procedure. 														
10	Exit the program.														

How to Configure for Remote Copy in SAP

Introduction This section describes how to configure your SAP system so that you can use the remote copy triggering method.

Procedure Use this procedure to set up RFC destination for Remote Copy in SAP.

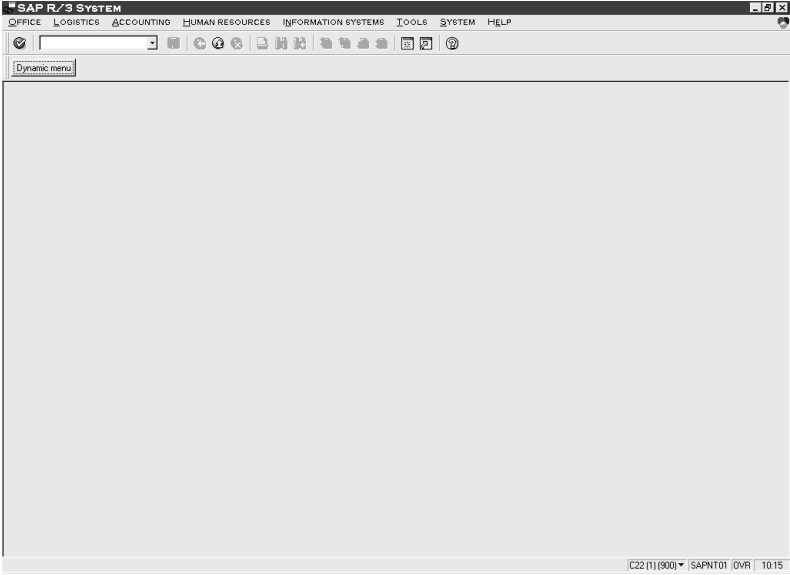
Step	Action
1	<p>Log on to your SAP system.</p> <p>System Response The system displays the SAP R/3 System dialog box.</p>  <p>(Continued on next page)</p>

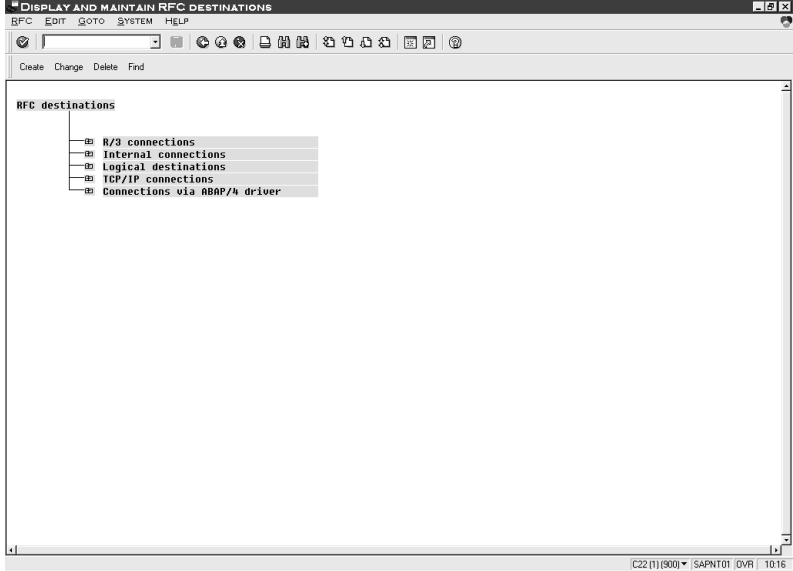
(Contd) Step	Action
2	<p>In the SAP R/3 System dialog box type SM59 transaction in the menu and click the check (✓) box.</p> <p>System Response The system displays the Display and Maintain RFC Destinations dialog box.</p>  <p style="text-align: right; color: red;">(Continued on next page)</p>

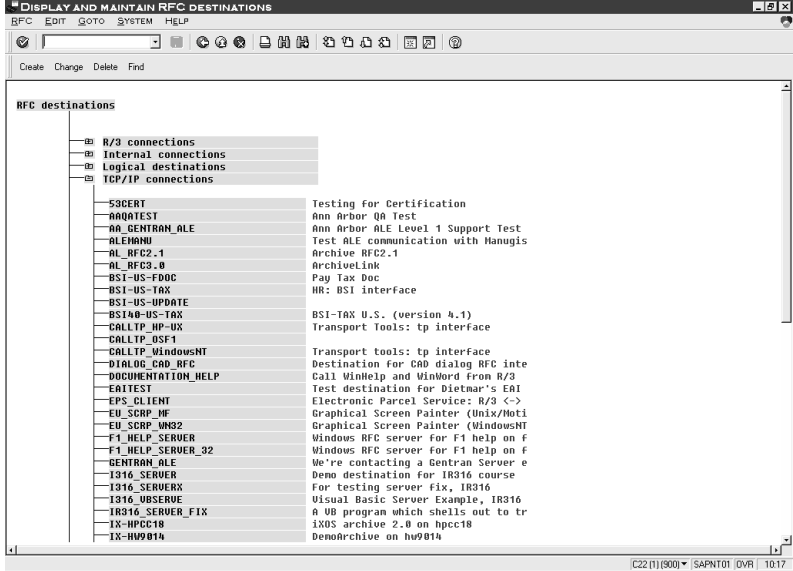
(Contd) Step	Action
3	<p>Click TCP/IP connections in the Display and Maintain RFC Destinations dialog box.</p> <p>System Response The folder expands to a bigger tree containing all the TCP/IP connections.</p>  <p style="text-align: right; color: red;">(Continued on next page)</p>

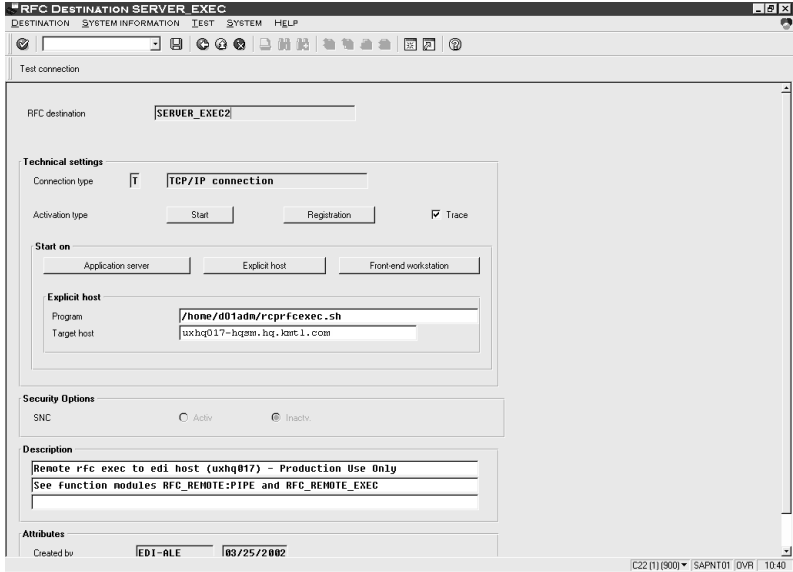
(Contd) Step	Action
<p>4</p>	<p>Double-click SERVER_EXEC in the TCP/IP list to open the Control Form.</p> <p>Note SERVER_EXEC is the name used in this example. Your GENTRAN:Server name could be different.</p> <p>System Response The system displays the RFC Destination SERVER_EXEC dialog box.</p> 
<p>5</p>	<p>Click Explicit host.</p>
<p>6</p>	<p>In the RFC Destination SERVER_EXEC dialog box make sure the following fields are filled in with the correct values:</p> <ul style="list-style-type: none"> ▶ Connection Type = T ▶ Activation Type = Click Start ▶ Program = The path to the GENTRAN:Server Extension for SAP supplied rcprfcexec.sh program. ▶ Target Machine = The DNS resolution name. ▶ Description = Whatever meets your implementation needs. <p>Note Trace can be used during configuration to help debug the system. When the system is configured and running correctly you can clear Trace.</p> <p style="text-align: right; color: red;">(Continued on next page)</p>

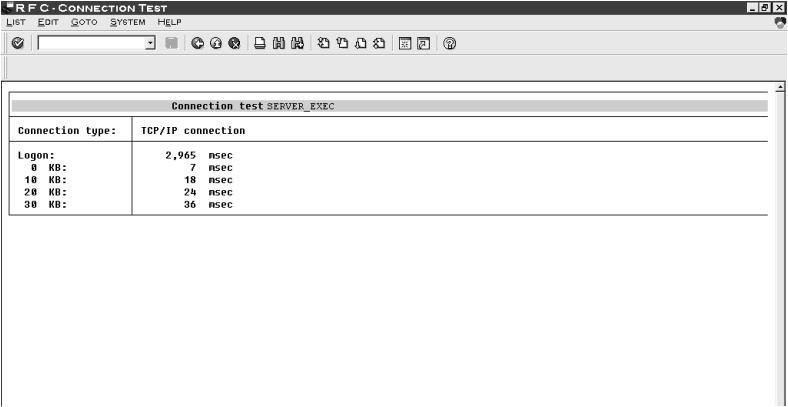
(Contd) Step	Action														
7	Save the configuration information for the RFC Destination SERVER_EXEC dialog box.														
8	<p>Click Test connection to test the connection and make sure this configuration is correct.</p> <p>System Response The system displays the RFC Connection Test dialog box containing connection information. If the connection is unsuccessful, you receive an unable to connect error message.</p>  <table border="1" data-bbox="623 705 1406 1108"> <thead> <tr> <th colspan="2">Connection test SERVER_EXEC</th> </tr> </thead> <tbody> <tr> <td>Connection type:</td> <td>TCP/IP connection</td> </tr> <tr> <td>Logon:</td> <td>2,965 nsec</td> </tr> <tr> <td>0 KB:</td> <td>7 nsec</td> </tr> <tr> <td>10 KB:</td> <td>18 nsec</td> </tr> <tr> <td>20 KB:</td> <td>24 nsec</td> </tr> <tr> <td>30 KB:</td> <td>36 nsec</td> </tr> </tbody> </table>	Connection test SERVER_EXEC		Connection type:	TCP/IP connection	Logon:	2,965 nsec	0 KB:	7 nsec	10 KB:	18 nsec	20 KB:	24 nsec	30 KB:	36 nsec
Connection test SERVER_EXEC															
Connection type:	TCP/IP connection														
Logon:	2,965 nsec														
0 KB:	7 nsec														
10 KB:	18 nsec														
20 KB:	24 nsec														
30 KB:	36 nsec														
9	<p>Does the dialog box show the LOGON timing information?</p> <ul style="list-style-type: none"> ▶ If yes, the Remote Copy Destination is fully operational. ▶ If no, verify the information that you entered in this procedure. 														
10	Exit the program.														

How to Use Register Mode to Define an ALE Environment

Introduction This topic describes how to define your SAP system using ALE.

Before you begin You must have the ALE server running before you begin this procedure.

Procedure Use this procedure to define an ALE environment using Register mode.

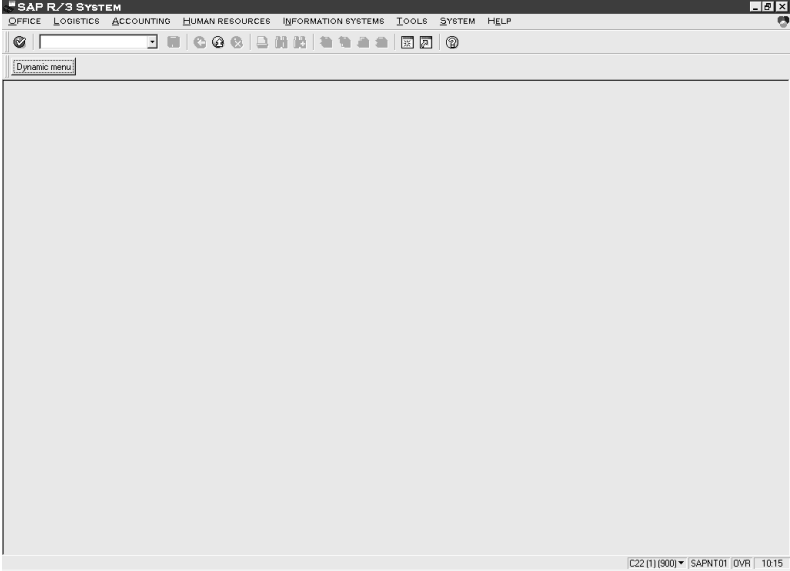
Step	Action
1	<p>Log on to your SAP system.</p> <p>System Response The system displays the SAP R/3 System dialog box.</p>  <p>(Continued on next page)</p>

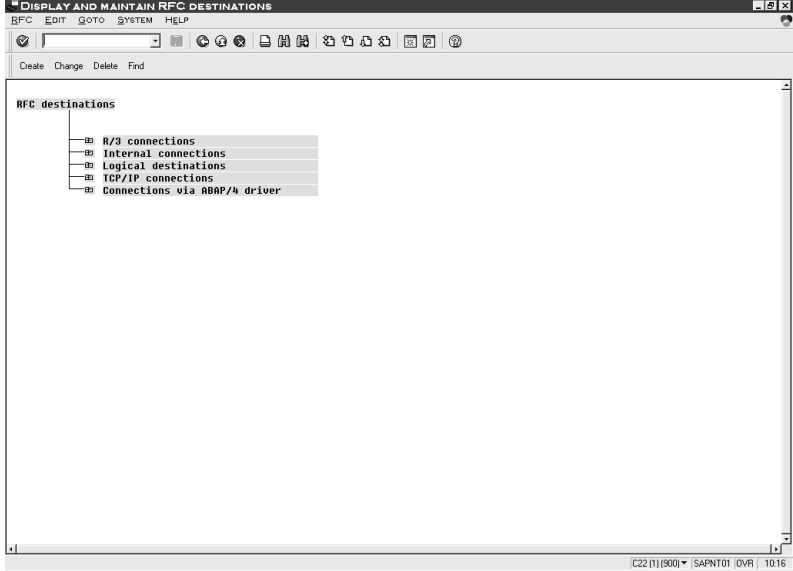
(Contd) Step	Action
2	<p>In the SAP R/3 System dialog box, enter SM59 in the menu.</p> <p>System Response The system displays the Display and Maintain RFC Destinations dialog box.</p> 
3	<p>Click the Create button to start an edit mode.</p> <p style="text-align: right; color: red;">(Continued on next page)</p>

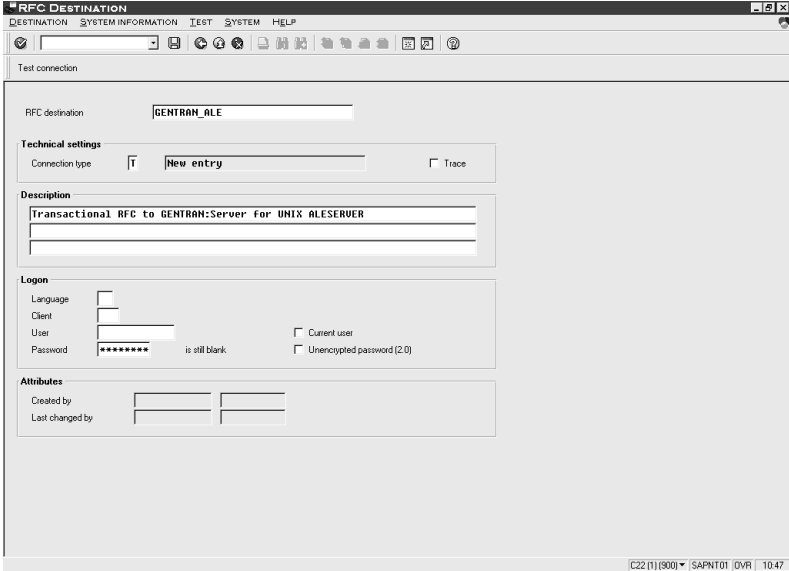
(Contd) Step	Action
4	<p>Double-click the TCP/IP connections folder in the Display and Maintain RFC Destinations dialog box.</p> <p>System Response The system displays the RFC Destination dialog box.</p> 
5	<p>Enter the RFC destination description in the RFC destination field</p> <p>Example GENTRAN_ALE</p>
6	<p>Under Technical Settings, enter T for Connection type.</p> <p>Note Trace can be used during configuration to help debug the system. When the system is configured and running correctly you can clear Trace.</p>
7	<p>Under Description, enter a program description according to your specifications.</p> <p style="text-align: right; color: red;">(Continued on next page)</p>

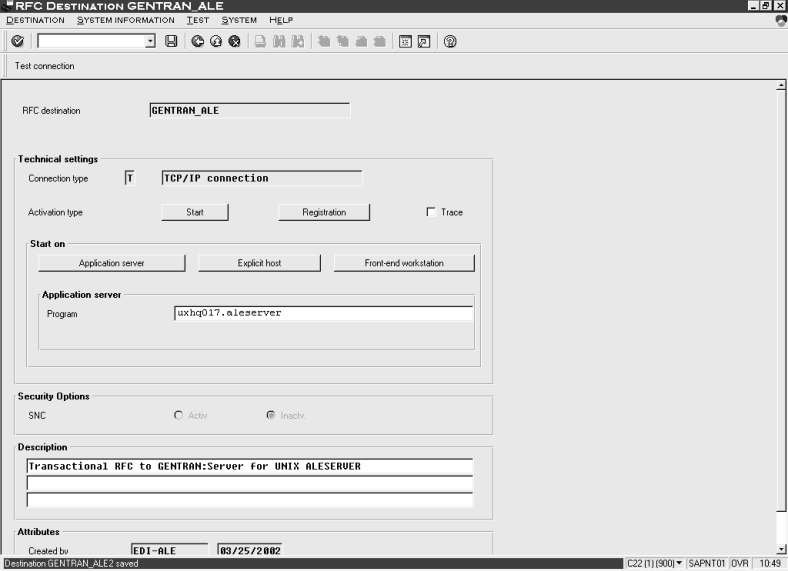
(Contd) Step	Action
8	<p>Save your entries in the RFC Destination dialog box.</p> <p>System Response The system displays the RFC Destination GENTRAN_ALE (for this example) dialog box.</p> 
9	Click Registration to add Program ID information.
10	<p>In the Program ID field, enter the information for the GENTRAN:Server instance (environment) that is started and running on the EDI host.</p> <p>Example In this command: aleserver -a uxhq017.aleserver -g uxhq008 -x sapgw00</p> <p>where:</p> <p>uxhq017.aleserver = the program ID used to register the service</p> <p>uxhq008 = the gateway server host name</p> <p>sapgw00 = the SAP gateway server TCP service name</p> <p>Note GENTRAN:Server must be up and running an ALE server before this setup is configured. If not, then SAP will not allow you to register.</p> <p style="text-align: right; color: red;">(Continued on next page)</p>

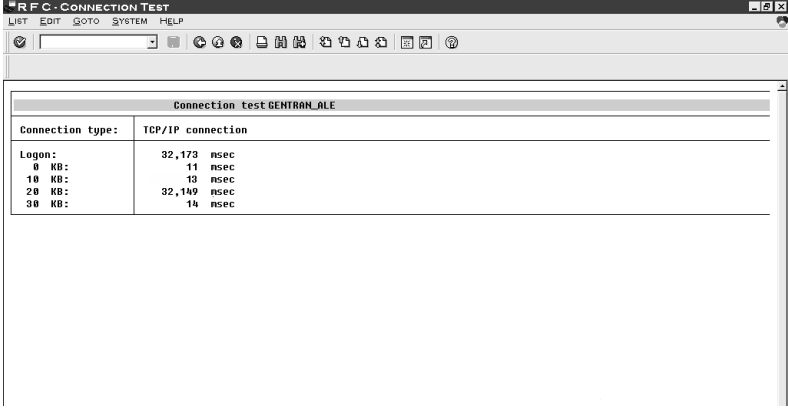
(Contd) Step	Action														
11	<p>Click Test connection to test the configuration.</p> <p>System Response The system displays the RFC Connection Test dialog box containing connection information. If the connection is unsuccessful, you receive an unable to connect error message.</p>  <p>The screenshot shows a window titled 'RFC CONNECTION TEST' with a menu bar (LIST, EDIT, GOTO, SYSTEM, HELP) and a toolbar. The main content area displays the following information:</p> <table border="1" data-bbox="630 678 1388 793"> <thead> <tr> <th colspan="2">Connection test GENTRAN_ALE</th> </tr> </thead> <tbody> <tr> <td>Connection type:</td> <td>TCP/IP connection</td> </tr> <tr> <td>Logon:</td> <td>32,173 nsec</td> </tr> <tr> <td>0 KB:</td> <td>11 nsec</td> </tr> <tr> <td>10 KB:</td> <td>13 nsec</td> </tr> <tr> <td>20 KB:</td> <td>32,149 nsec</td> </tr> <tr> <td>30 KB:</td> <td>14 nsec</td> </tr> </tbody> </table>	Connection test GENTRAN_ALE		Connection type:	TCP/IP connection	Logon:	32,173 nsec	0 KB:	11 nsec	10 KB:	13 nsec	20 KB:	32,149 nsec	30 KB:	14 nsec
Connection test GENTRAN_ALE															
Connection type:	TCP/IP connection														
Logon:	32,173 nsec														
0 KB:	11 nsec														
10 KB:	13 nsec														
20 KB:	32,149 nsec														
30 KB:	14 nsec														
12	If the connection is successful, save this configuration.														
13	Exit the program.														

SAP Port Configuration

How to Configure an RFC Port Definition

Introduction SAP allows you to configure for specific port definitions such as RFC.

Configuring an RFC Port Definition Use this procedure to configure an RFC Port Definition.

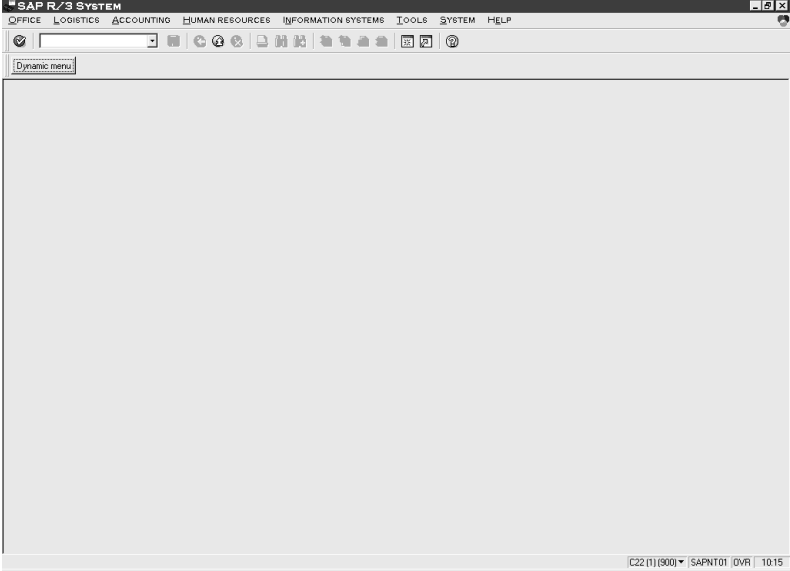
Step	Action
1	<p>Log on to your SAP system.</p> <p>System Response The system displays the SAP R/3 System dialog box.</p>  <p style="text-align: right; color: red;">(Continued on next page)</p>

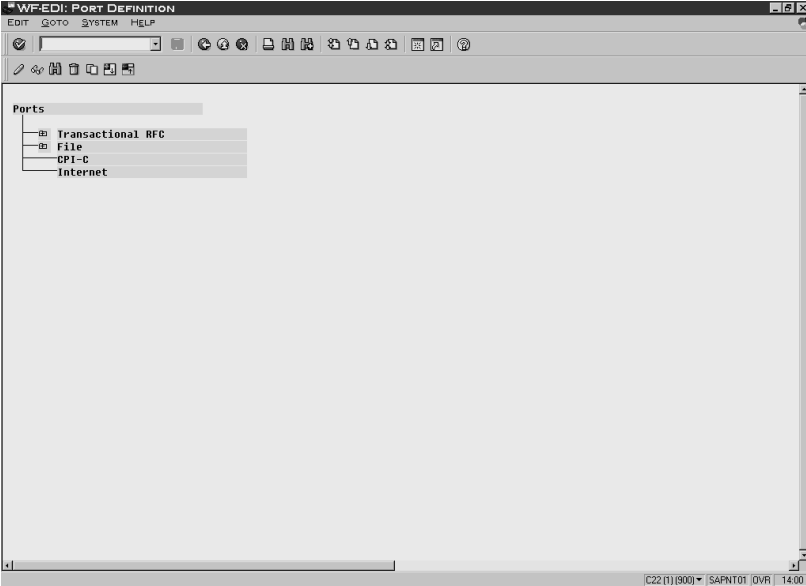
(Contd) Step	Action
2	<p>In the SAP R/3 System dialog box enter WE21 in the menu and click the check (✓) box.</p> <p>System Response The system displays the WF-EDI: Port Definition dialog box.</p>  <p style="text-align: right; color: red;">(Continued on next page)</p>

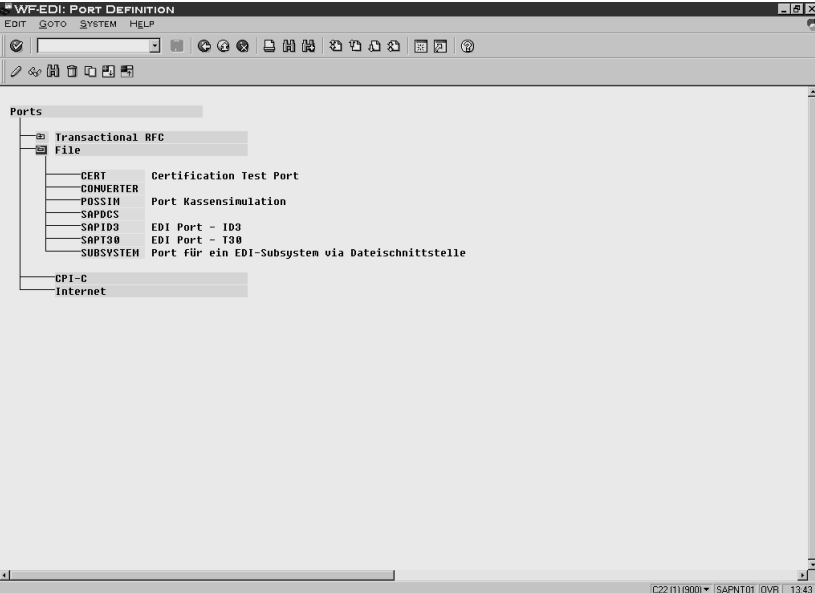
(Contd) Step	Action
3	<p>Double-click on File folder in the WF-EDI: Port Definition dialog box.</p> <p>System Response The folder expands to a bigger tree containing all the Port Definitions.</p>  <p>(Continued on next page)</p>

(Contd) Step	Action
4	<p>Double-click on the port you want to define.</p> <p>System Response The system displays the Display View “Port Definition for File”: Details dialog box.</p>
5	<p>In the Display View “Port Definition for File”: Details dialog box make sure the following fields are filled in with the correct values:</p> <ul style="list-style-type: none"> ▶ Description = Whatever meets your needs. ▶ Version = 2 (for a version 3.0/3.1 control record). ▶ Version = 3 (for a version 4.0 control record).
6	<p>Click Command file to set up the command file parameters.</p> <p>System Response The system displays the Parameters for Command File dialog box.</p> <p style="text-align: right; color: red;">(Continued on next page)</p>

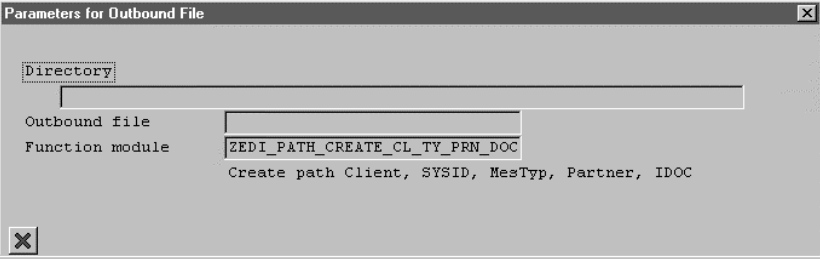
(Contd) Step	Action
7	<p>Do you want this port capable of realtime triggering?</p> <ul style="list-style-type: none"> ▶ If YES, check the Autom.start possible box and continue with the next step. ▶ If NO, continue with the next step. <p>Note If this box is <u>not</u> checked, SAP will not trigger GENTRAN:Server.</p>
8	<p>Complete the Log. destination field with the RFC destination you previously set up in the SM59 transaction.</p>
9	<p>Complete the Directory field with the pathname to the “bin” directory in your GENTRAN:Server installation.</p> <p>Example In this example we are using <code>/n_gentran/server511/dev/bin/</code> as a directory pathname.</p> <p>Note You must have a slash (/) at the end of the pathname.</p>
10	<p>Complete the Shell script field with the name of the GENTRAN:Server supplied receiver program:</p> <p>receiveidoc.sh</p>
11	<p>Click the X button to return to the Display View “Port Definition for File”: Details dialog box.</p>
12	<p>Click Outbound file to set up the outbound file parameters.</p> <p>System Response The system displays the Parameters for Outbound File dialog box.</p>  <p style="text-align: right; color: red;">(Continued on next page)</p>

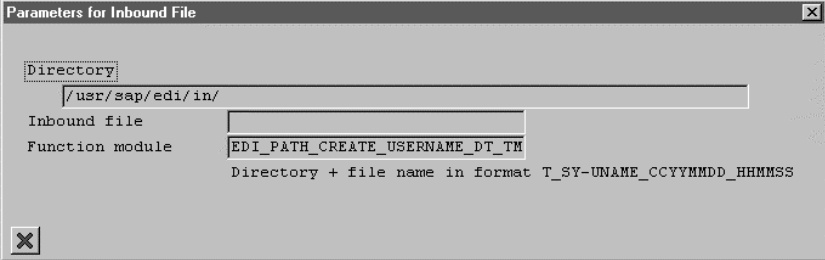
(Contd) Step	Action
13	Complete the Directory field with the complete path for the outbound file. Example Enter the path <code>/sapmnt/{INSTANCE}/global/edi</code> where INSTANCE equals the three-character name of the SAP instance.
14	Complete the Function module field to one that will guarantee data integrity for your system. Note Information about the client and IDoc number is the best for the function module.
15	Click the X button to return to the Display View “Port Definition for File”: Details dialog box.
16	Click Inbound File to set up the inbound file parameters. System Response The system displays the Parameters for Inbound File dialog box. 
17	The fields in the Parameters for Inbound File dialog box do not necessarily have to be completed. GENTRAN:Server will tell SAP where the file is located and what function module to use. Recommendation We recommend that for documentation purposes you should set the directory path to the place where files are already being transferred (like in the Outbound parameters). Set the function module to the one used in the GENTRAN:Server implementation (EDI_DATA_INCOMING).
18	Click the X button to return to the Display View “Port Definition for File”: Details dialog box. <div style="text-align: right; color: red;">(Continued on next page)</div>

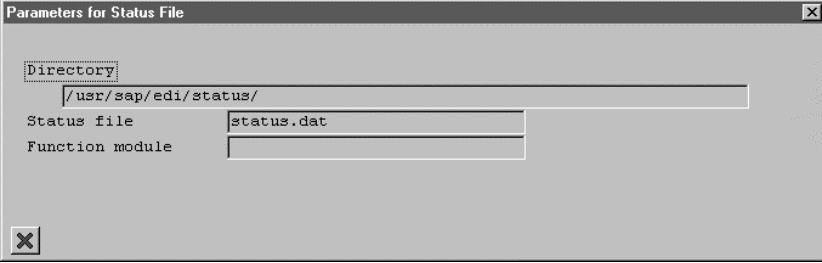
(Contd) Step	Action
19	<p>Click Status file to set up the inbound file parameters.</p> <p>System Response The system displays the Parameters for Status File dialog box.</p> 
20	<p>Completing the fields in the Parameters for Status File dialog box is optional. GENTRAN:Server tells SAP where the file is located and what function module to use.</p> <p>Recommendation We recommend that for documentation purposes you should set the directory path to the place where files are already being transferred (like in the Outbound parameters). Set the function module to the one used in the GENTRAN:Server implementation (EDI_DATA_INCOMING).</p>
21	Click the X button to return to the Display View “Port Definition for File”: Details dialog box.
22	Save the changes to the Display View “Port Definition for File”: Details dialog box to complete the RFC Port Definition.

How to Configure an ALE Port Definition

Introduction SAP allows you to configure for specific port definitions such as ALE.

Before you begin You may need a Change Request Number in order to complete this process. Check with your SAP system administrator to determine if you need a Change Request Number.

Configuring an ALE Port Definition Use this procedure to configure an ALE Port Definition.

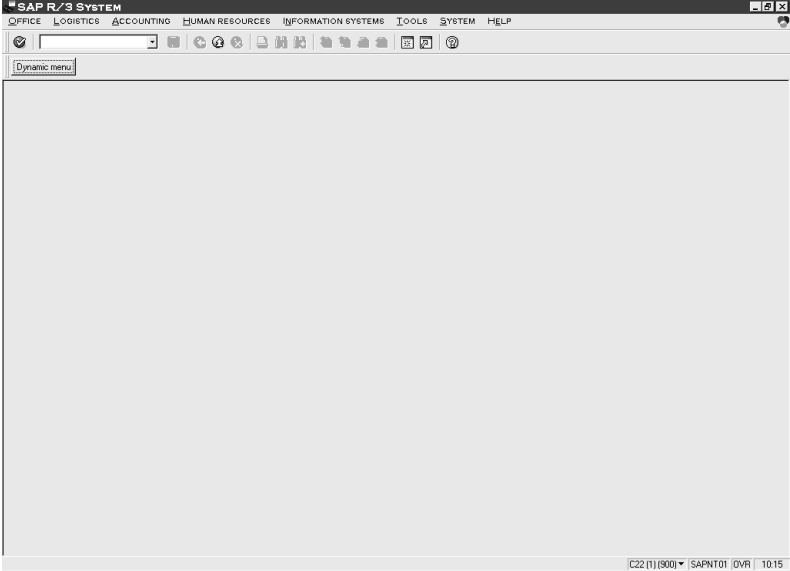
Step	Action
1	<p>Log on to your SAP system.</p> <p>System Response The system displays the SAP R/3 System dialog box.</p>  <p style="text-align: right; color: red;">(Continued on next page)</p>

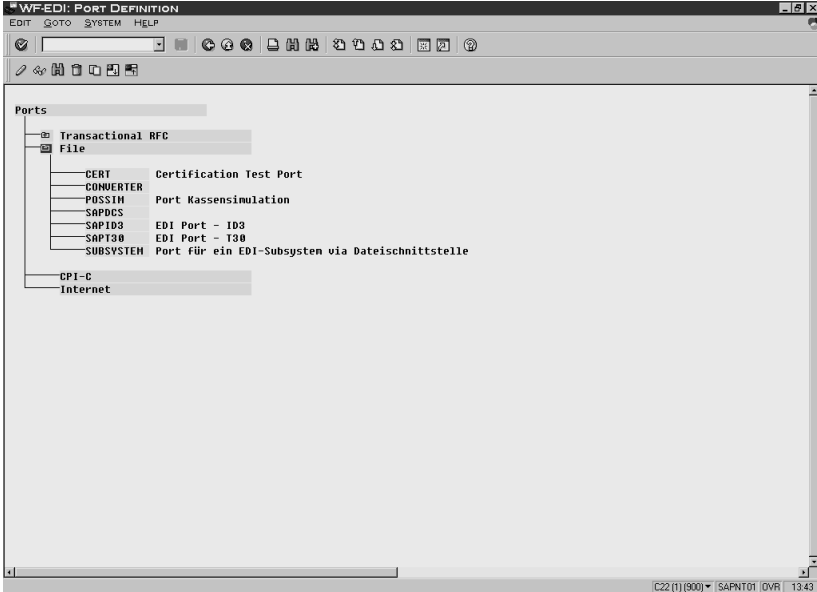
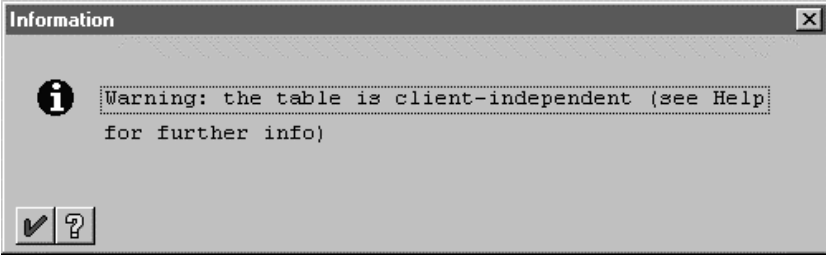
(Contd) Step	Action
2	<p>In the SAP R/3 System dialog box enter WE21 in the menu and click the check (✓) box.</p> <p>System Response The system displays the WF-EDI: Port Definition dialog box.</p> 
3	<p>Double-click on Transactional RFC folder in the WF-EDI: Port Definition dialog box.</p> <p>System Response The system may display a warning dialog box telling you that the table is client-independent.</p>  <p style="text-align: right; color: red;">(Continued on next page)</p>

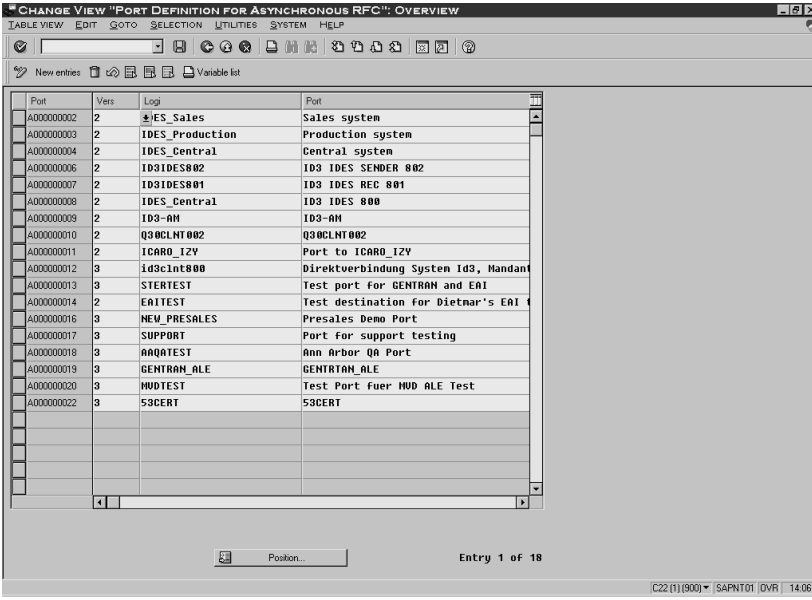
(Contd) Step	Action
4	<p>Is the warning dialog box in the previous step displayed?</p> <ul style="list-style-type: none"> ▶ If YES, click the check (✓) box to confirm your understanding. ▶ If NO, continue with the next step. <p>System Response The system displays the Change View “Port Definition for Asynchronous RFC”: Overview dialog box.</p>
5	<p>Click the Change icon.</p> <p>System Response The system displays a New entries button.</p>
6	<p>Click New entries in the Change View “Port Definition for Asynchronous RFC”: Overview dialog box.</p> 
7	<p>Complete the Description field.</p>
8	<p>In the Logical destination field, enter the name of the port defined earlier.</p> <p>Note For example, GENTRAN_ALE.</p> <p style="text-align: right; color: red;">(Continued on next page)</p>

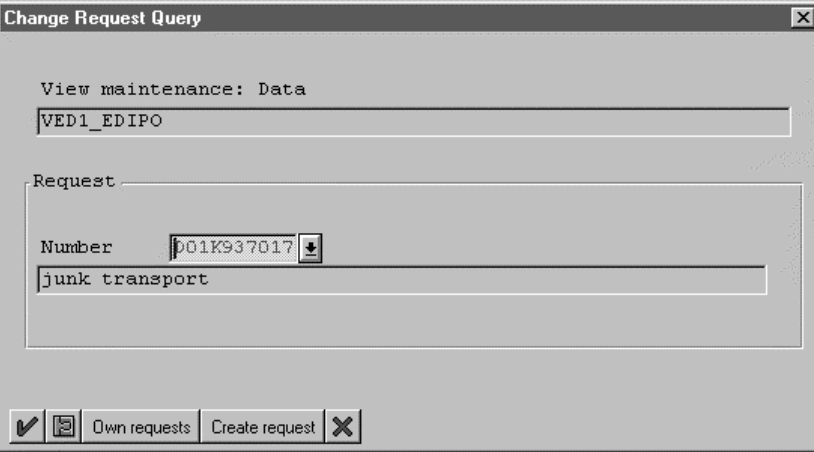
(Contd) Step	Action
9	<p>Save the information.</p> <p>System Response The system may display the Change Request Query dialog box.</p> 
10	<p>Is the Change Request Query dialog box displayed?</p> <ul style="list-style-type: none"> ▶ If YES, select your Change Request Number from the Number pull down menu and then continue with Step 11. ▶ If NO, continue with Step 13.
11	Save the Change Request Number and continue with the next step.
12	<p>A sequential port number is now present in the Port field of the Change View “Port Definition for Asynchronous RFC”: Overview dialog box. You can now change partner profiles to use this port for ALE distribution.</p> <p>Note This is the port number used in the SAP extension configuration GUI interface.</p>
13	Save the information to complete the ALE Port Definition.

File-Based Triggering

How to Configure Inbound File-Based Triggering

Introduction Use the information in this topic to configure triggering for your installation.

Before you begin Before you configure trigger methods, you must set up a login for the EDI system for each SAP application server host.

Logins If the extension resides on:

- The same system as SAP, then use the trigger login that was used during installation of GENTRAN:Server 6.0.
- Another system, then set up the GENTRAN:Server 6.0 login on each application server that is not located on the same host as the extension.

Reference

See the *SAP WF-EDI Intermediate Document-Triggering Manual* for more information.

How to set up NFS-based triggering

Use this procedure to set up inbound NFS-based triggering.

Step	Action
1	<p>Mount the directory structure used to transfer IDoc data to SAP. The NFS file system must be mounted along the same pathname on each system.</p> <p>Exception If the NFS file system is not mounted along the same pathname, complete Step 2.</p> <p>Note This is the directory structure defined in the SAP port definition for each port you want to use with the extension.</p> <p style="text-align: right; color: red;">(Continued on next page)</p>

(Contd) Step	Action
2	Establish symbolic links to ensure common pathnames to the IDoc data on each system. When to Use Complete this step only if the NFS file system is not mounted along the same pathname on each system.

How to set up the RCP-based Trigger

Complete the following steps if you want to set up inbound RCP-based triggering.

Step	Action
1	Ensure that the GENTRAN:Server user ID can execute a remote shell on the SAP application host. <ul style="list-style-type: none"> ▶ Log on to the EDI system using the GENTRAN:Server user ID. ▶ Execute a remote shell command to the SAP application server host. Command Example <pre><remsh>SAP_Application_Server_hostname>whoami</pre> System Response If whoami prints your user's name, then remote access is configured properly.
2	Ensure that the GENTRAN:Server account has access to the SAP-provided startRFC program. Reference See the SAP system documentation for instructions and/or the How to Configure for Remote Copy in SAP topic in this chapter.

How to Configure Outbound File-Based Triggering

Introduction Use the information in this topic to configure triggering for your installation.

Before you begin Before you configure trigger methods, you must set up trigger logins for each SAP system ID that may invoke the extension's outbound trigger. The login must be set up on the host that contains the extension.

Logins If the extension resides on:

- ▶ The same system as SAP, then the trigger login was used during SAP installation.
- ▶ Another system, then set up the SAP login for each SAP system ID that is not located on the same host as the extension.

Reference

See the *SAP WF-EDI Intermediate Document-Triggering Manual* for more information.

How to set up NFS-based triggering

Use this procedure to set up outbound NFS-based triggering.

Step	Action
1	<p>Mount the directory structure used to transfer IDoc data to SAP. The NFS file system must be mounted along the same pathname on each system.</p> <p>Exception If the NFS file system is not mounted along the same pathname, complete step 2.</p> <p>Note This is the directory structure defined in the SAP port definition for each port you want to use with the extension.</p> <p style="text-align: right; color: red;">(Continued on next page)</p>

(Contd) Step	Action
2	<p>Establish symbolic links to ensure common pathnames to the IDoc data on each system.</p> <p>When to Use Complete this step only if the NFS file system is not mounted along the same pathname on each system.</p>
3	<p>Verify that the trigger login user has access to the rfcexec program by completing the following tasks:</p> <ul style="list-style-type: none"> ▶ Log on to the SAP system using the trigger login user ID. ▶ Execute a remote shell command on the EDI subsystem host. <p>Command Example</p> <pre><rsh> <EDI_hostname> rfcexec</pre> <p>Result If rfcexec starts, then the trigger is configured properly.</p>
4	<p>Log on to SAP and test the RFC destination.</p> <p>Reference See the SAP system documentation for instructions and/or How to Configure for NFS in SAP topic in this chapter.</p>
5	<p>Ensure that each SAP logical port that uses the extension is configured to invoke the \$EDI_ROOT/bin/receiveidoc.sh outbound trigger program.</p> <p>Note You can set the environment variable \$EDI_ROOT by inserting it in the .kshrc file for the account that the SAP system is using to log in and run edirfcexec.</p>

(Continued on next page)

How to set up the Non-nfs-based Trigger

Complete the following steps if you want to set up outbound non-NFS-based triggering.

Step	Action
1	Ensure that the trigger login user has access to the extension programs rcprfcexec and exterror . (The extension program rcprfcexec initiates the extension trigger, exterror is the extension error logging program.)
2	Ensure that the trigger login user has access to the SAP-provided rfcexec program.
3	<p>Verify that the trigger login user has access to the rfcexec program by completing the following tasks:</p> <ul style="list-style-type: none"> ▶ Log on to the SAP system using the trigger login user ID. ▶ Execute a remote shell command on the EDI subsystem host. <p>Command Example</p> <pre><rsh> <EDI_hostname> rfcexec</pre> <p>Result If rfcexec starts, then the trigger is configured properly.</p>
4	<p>Log onto SAP and test the RFC destination.</p> <p>Reference See the SAP system documentation for instructions and/or SAP Connectivity Configuration section in this manual.</p>
5	Ensure that each SAP logical port that uses the extension is configured to invoke the \$EDI_ROOT/bin/receiveidoc.sh outbound trigger program.

Configuring Inbound Extension Processing

Contents	Overview	
	▶ Introduction	3
	▶ The Flow of Work	4
	▶ How to Create the Supporting Files	6
	Generating FA Status Messages	
	▶ Overview	7
	▶ How to Configure for FA Status Messages	8
	Naming the Process Flow	
	▶ Flow Identification Dialog Box	10
	▶ How to Name and Describe the Flow	12
	Creating an Inbound SAP Flow	
	▶ Overview	14
	▶ Source Agent Dialog Box	16
	▶ How to Set Up the Source Agent	19
	▶ Processing Agent Dialog Box	22
	▶ Translation Options Dialog Box	25
	▶ How to Set Up the Processing Agent	27
	▶ Delivery Agent Dialog Box	29
	▶ How to Set Up the Delivery Agent	31
	Completing a Flow	
	▶ Overview	34
	▶ Error Handling Dialog Box	35
	▶ How to Set Up Error Handling Instructions	37
	▶ Trading Partner Records Dialog Box	40
	▶ How to Add Trading Partnerships to the Flow	42

Configuring an Inbound Route to SAP

- ▶ Overview 44
 - ▶ How to Create an Inbound Route (to SAP) 51
-

Overview

Introduction

In this chapter

To route document files to SAP, you need to:

- ▶ Configure for FA Status Messages
 - ▶ Configure inbound flow
 - ▶ Create an inbound SAP route
-

The Flow of Work

Task summary

This table summarizes the tasks you must complete to configure for inbound extension processing.

Task	Description
1	<p>Configure SAP to accept inbound IDocs.</p> <ul style="list-style-type: none"> ▶ Set up RFC Destination <p>Reference See the Extension Triggering chapter in this guide.</p> <ul style="list-style-type: none"> ▶ Set up SAP Port Definitions ▶ Set up Partner Profile Definition <p>Reference See Chapter 1 of the SAP System R/3 Release 3.0 EDI Interface Configuration Manual for more information.</p>
2	<p>Set up the GENTRAN:Server inbound Trading Partnership codes.</p> <p>Reference See the Working with Trading Partnerships chapter in the <i>GENTRAN:Server Application Integration User's Guide</i>.</p>
3	<p>Set up the GENTRAN:Server inbound Maps.</p> <p>Reference See the Designing Your Map chapter in the <i>GENTRAN:Server Application Integration User's Guide</i>.</p>
4	<p>Create the supporting files.</p> <p>Reference See Naming the Process Flow in this chapter.</p>
5	<p>If you want to generate status messages for inbound Functional Acknowledgments, configure your system to obtain the IDoc number and mailbag ID (mailbagid) of the original outbound translation from the audit record (edihist).</p> <p>Reference See Generating FA Status Messages in this chapter.</p> <p style="text-align: right;">(Continued on next page)</p>

(Contd) Task	Description
6	Name the new process flow. Reference See Naming the Process Flow . in this chapter.
7	Use the PCM wizard to configure the data managers (agents) for the inbound process flow. Reference See Creating an Inbound SAP Flow .
8	Complete the process flow. Reference See Completing a Flow .
9	Set up an Inbound extension route to SAP. Reference See How to Create an Inbound Route (to SAP) .

Flow guidelines

Follow these guidelines when creating a new process flow:

- Give each flow in your system a unique name.
 - Use a unique name for each data manager in your system.
 - Use the flow description to help identify the flow.
-

How to Create the Supporting Files

Introduction Before you create a new process flow, you should create the supporting files you plan to use in the process flow. These include:

- ▶ Trading Partnership records and categories
- ▶ Scripts
- ▶ Directories and queries

Procedure Use this procedure to create a new process flow.

Step	Action
1	Create Trading Partnerships records and categories.
2	<p>Do you want to run a GENTRAN:Server script after files are processed?</p> <ul style="list-style-type: none"> ▶ If YES, create the script and move it to the <i>./script</i> directory. ▶ If NO, continue with Step 2. <p>Reference PCM Customers: For instructions on creating scripts, see Working With Scripts in the <i>GENTRAN:Server Data Flow Administration Guide</i>. EC Workbench Customers: For instructions on creating scripts, see Working With Scripts in the <i>GENTRAN:Server Data Flow Administration Guide</i>.</p>
3	<p>Do you want to use <i>./error</i> as the error directory?</p> <ul style="list-style-type: none"> ▶ If YES, you may create your process flow. ▶ If NO, create an error directory to hold error messages and erroneous data.

Generating FA Status Messages

Overview

Supported FA status messages

The SAP Extension supports these Functional Acknowledgment status messages:

- ▶ 16 - Set acknowledged and accepted
- ▶ 17 - Set rejected

Support requirements

To generate these status messages, the SAP Extension must obtain the IDoc number and mailbagid of the original outbound IDoc from the edihist audit record.

The system automatically stores the mailbagid in the audit record as part of the input file name. However, you must configure your system to place the original IDoc number into the outbound audit record.

There are two ways to configure the extension to place the original IDoc number in the outbound audit record:

- ▶ Configure your system to read the content of the User Buffer field of the EDI audit record, edihist.dat/.idx.

If you use the Visual Mapper, you will map the IDoc number to the \$USRBUF variable, which stores content in the User Buffer field of the audit record.

If you use the Application Integration mapper, you will use the setparam extended rule with PARAM(0) to store a mapped value to the User Buffer field of the audit record.

- ▶ Include the IDoc number as the part of the Document Reference Number, which is written to the audit record.
-

How to Configure for FA Status Messages

Procedure Use this procedure to configure an inbound SAP flow to generate Functional Acknowledgment status messages.

Task	Description	
1	Configure your system to place the IDoc number of the original outbound file into the edihist audit record.	
	IF you want to...	THEN...
	use the Application Integration mapper and store the IDoc number in the audit record's User Buffer field	use the setparam extended rule to set PARAM(0). Reference See the Using Extended Rules chapter in the <i>GENTRAN:Server Application Integration User's Guide</i> for information.
	use the Visual Mapper and store the IDoc number in the audit record's User Buffer field	map the IDoc number to the \$USRBUF audit system variable. Reference See the Archiving Data chapter in the <i>GENTRAN:Server Mapping and Translation Guide</i> for instructions.
include the IDoc number in the Document Reference Number	include the IDoc number in the Document Specifier map. Note the position (offset) of the IDoc number in the Document Specifier map. You will need the offset when you complete the Processing agent dialog box. Reference See the Defining the Document Reference Number chapter in the <i>GENTRAN:Server Data Flow Administration Guide</i> . (Continued on next page)	

(Contd) Task	Description
2	<p>Create the inbound SAP flow, configuring the Processing agent to archive data and to generate Functional Acknowledgments/Control status messages.</p> <p>Reference See Naming the Process Flow and Creating an Inbound SAP Flow in this chapter.</p> <p>When you set up the processing agent for the SAP Extension, you must indicate on the dialog box which method the extension should use to obtain the IDoc number.</p> <p>Reference See the How to Set Up the Processing Agent topic in this guide.</p>
3	<p>Complete the flow.</p> <p>Reference See the Completing a Flow section in this guide.</p>

Naming the Process Flow

Flow Identification Dialog Box

Introduction

The Flow Identification dialog box names and describes the process flow. This dialog box is in the same format for all flow types.

Flow Identification dialog box

This illustration shows the Flow Identification dialog box.

The screenshot shows a dialog box titled "Flow Identification". Inside the dialog, there is a section labeled "Flow Information" which contains three input fields: "Name" (a text box), "Description" (a text box), and "Type" (a dropdown menu). At the bottom of the dialog, there are four buttons: "< Back", "Next >", "Cancel", and "Help".

(Continued on next page)

**Flow
Identification
fields and
functions**

This table describes the fields of the Flow Identification dialog box and their functions.

Field	Function
Name	Defines the name of the process flow (the name is limited to 15 characters).
Description	Describes the process flow (Optional).
Type	Enables you to select the type of process flow. <ul style="list-style-type: none">▶ Standard-to-SAP▶ Application-to-SAP▶ SAP-to-standard▶ SAP-to-application <p>Note This list may appear different in your installation.</p>

How to Name and Describe the Flow

Introduction The first step in creating a new process flow is to name the flow, describe it, and select the flow type.

Procedure Use this procedure to name and describe the process flow and select the flow type.

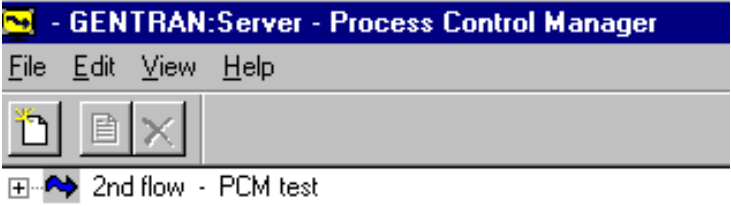
Step	Action
1	<p>Click the PCM button on the GENTRAN:Server client toolbar to start the Process Control Manager.</p> <div data-bbox="987 884 1065 957" style="text-align: center;">  </div> <p>System Response GENTRAN:Server displays a tree that shows all the existing flows. This example has only one flow.</p> <div data-bbox="659 1121 1385 1325" style="border: 1px solid black; padding: 5px;">  </div> <p style="text-align: right; color: red;">(Continued on next page)</p>

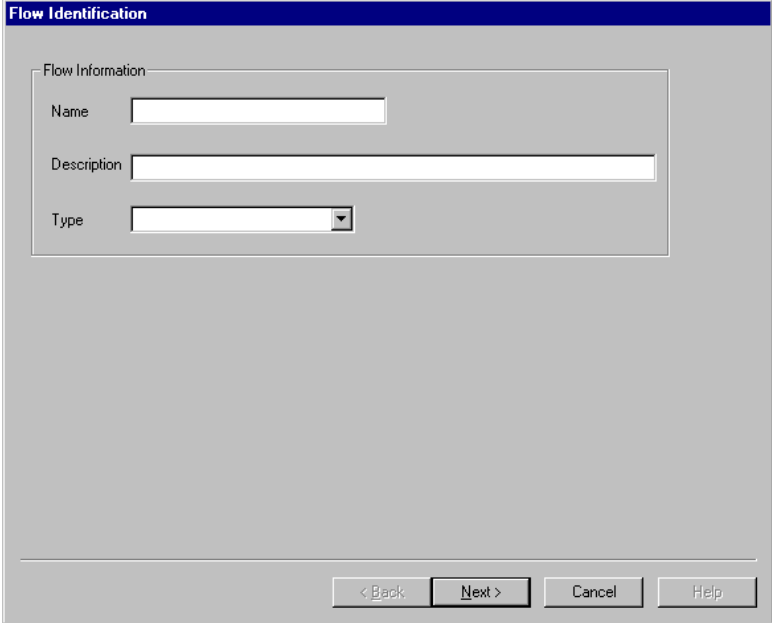
(Contd) Step	Action
2	<p>Click New on the File menu to start the wizard.</p> <p>System Response GENTRAN:Server displays the Flow Identification dialog box.</p> 
3	<p>Complete the boxes.</p> <p>WARNING You must name the flow and select a flow type. The description is optional, but we recommend that you include a description.</p>
4	<p>Click Next to continue to the Source agent dialog box.</p> <p>References See Creating an Inbound SAP Flow in this chapter. See the How to Set Up the Source Agent topic in this chapter.</p>

Creating an Inbound SAP Flow

Overview

Flow types

The inbound SAP flow types are:

- ▶ Standard-to-SAP
- ▶ Application-to-SAP.

Data managers in an inbound SAP flow

An inbound SAP flow has three data managers:

- ▶ Source agent - Processes standard or application data. Starts the movement of data in the flow.
- ▶ Processing agent - Starts a translation script that runs the translator, **Iftran**.
- ▶ Delivery agent - Runs a script to perform SAP-specific after-translation processing on the data.

Routing direction

This table describes the routing direction in an inbound SAP flow.

Stage	Description
1	A source agent: <ul style="list-style-type: none"> ▶ Receives standard or application files ▶ Splits standard or application files by trading partner ▶ Processes data and routes standard or application data to the processing agent.
2	The processing agent runs the translator, Iftran , which translates the data and routes it to a delivery agent. <p style="text-align: right; color: red;">(Continued on next page)</p>

(Contd) Stage	Description
3	<p>The delivery agent runs a translation script to prepare the data for SAP applications.</p> <p>Comment For both standard-to-SAP and application-to-SAP flows, the translation script performs SAP-specific processing. This script is supplied with your GENTRAN:Server SAP Extension software. The name of the script is <code><data_manager_name>_sid.scr</code></p>

**Example:
Inbound FA flow**

This diagram illustrates an inbound flow for Functional Acknowledgments a trading partner sends to you.

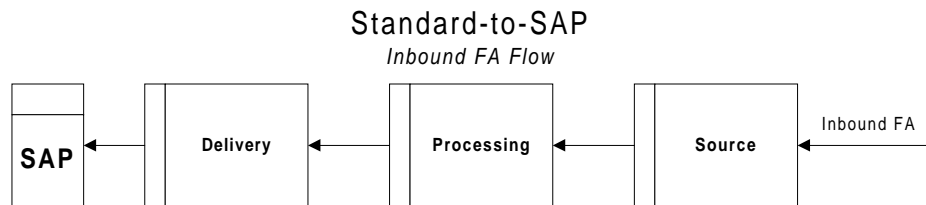

Source Agent Dialog Box

Introduction The Source agent dialog box for an inbound flow creates the inbound data manager that starts your process flow.

Illustration This illustration shows the Source agent dialog box.

The screenshot shows the 'Source' dialog box with the following configuration:

- Agent Name: sr07
- New File Detection:
 - Queue
 - Directory Scan
 - Source Directory: ./inbd
- Scan Frequency:
 - Once
 - Periodically
 - Every: 0 Hour(s) 0 Minute(s) 3 Second(s)
- Split Files By:
 - Interchange
 - Group
 - Transaction Set

Buttons at the bottom: < Back, Next >, Cancel, Help

(Continued on next page)

Source agent dialog box fields and functions

This table describes the fields of the Source agent dialog box and their functions.

Field	Function
Agent Name	<p>Defines the name of the source data manager. The name cannot be longer than four characters (A to Z and 0 to 9).</p> <p>Note The system supplies a default name, which is based on file type selected on the Flow Identification dialog box. You can override the default name.</p>
Queue	Selects queue as the source type that the data manager scans for new files to process.
Queue Name	Enables you to select (from the list) the name of the queue that the data manager scans for new files. The Queue Name list contains the names of all the existing queues.
Directory Scan	Selects a scan directory as the source type that the data manager scans for new files to process.
Source Directory	<p>Enables you to type or select the name of the directory that the data manager scans for new files. If you choose to type the name, use the relative path for EDI_ROOT.</p> <p>Note If the first character in the name is a forward slash then the system uses absolute path. If anything else is used the system assumes relative path.</p> <p>Note If the directory name does not exist, the PCM wizard displays a prompt that asks if you want to create the directory.</p>
Once	Selects one time as the scan frequency.
Periodically	Enables you to select the frequency with which you want the source data manager to scan its source directory.
Hour(s)	<p>Defines, in hours, the frequency with which the data manager scans for new data.</p> <p style="text-align: right;">(Continued on next page)</p>

(Contd) Field	Function
Minute(s)	Defines, in minutes, the frequency with which the data manager scans for new data.
Second(s)	Defines, in seconds, the frequency with which the data manager scans for new data. The default value is 3 seconds.
Interchange	Selects interchange code as the splitting method to route files. Note This option is not available for inbound SAP (standard-to-SAP or application-to-SAP) flows. Inbound SAP files must be split by Trading Partnership code.
Group	Selects group code as the splitting method to route files.
Transaction Set	Selects transaction set as the splitting method to route files. This selection is the default value on this dialog box.

How to Set Up the Source Agent

Introduction The source agent, which has an inbound (inbd or appm) personality, starts the process flow.

Before you begin You must create the supporting files and name the flow before you begin.

References

See [Naming the Process Flow](#) and [How to Name and Describe the Flow](#) for instructions.

(Continued on next page)

Procedure Use this procedure to set up the source data manager for an inbound flow.

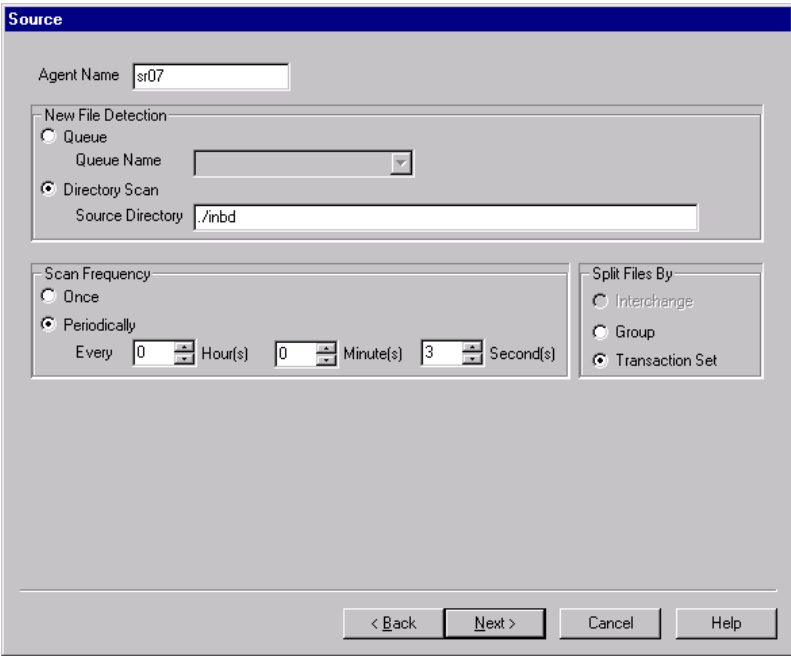
Step	Action
1	<p>Type the name of the source data manager in the Agent Name box.</p> <p>Comment GENTRAN:Server supplies a default name. You can override the name.</p>  <p>Note The Agent name is limited to 4 alphanumeric characters.</p>
2	<p>Select either Queue or Directory Scan as the type of source that you want the source data manager to examine for files to process.</p>
3	<p>Is the source a queue?</p> <ul style="list-style-type: none"> ▶ If YES, select the name of the queue from the Queue Name list. ▶ If NO, (the source is a directory), type the relative path name to the directory in the text box. <p style="text-align: right; color: red;">(Continued on next page)</p>

(Contd) Step	Action
4	Click Once or Periodically to select the scan frequency. Note The scan frequency you select applies to every data manager in the flow.
5	Did you select Periodically in Step 4? <ul style="list-style-type: none">▶ If YES, complete the Hour(s), Minute(s) and Second(s) boxes to select the frequency with which the data manager awakens and scans the queue or directory.▶ If NO, continue with Step 6.
6	Click Group or Transaction Set to select how the data manager groups route data.
7	Click Next to continue to the Processing agent dialog box. Reference See How to Set Up the Processing Agent .

Processing Agent Dialog Box

Introduction

In an inbound SAP flow, the processing agent dialog box defines translation options.

Processing agent dialog box

This illustration shows the Processing agent dialog box for an inbound SAP flow.

The screenshot shows a dialog box titled "Processing" with a close button (X) in the top right corner. The dialog contains the following fields and options:

- Agent Name: pr00
- Translation Settings section:
 - Translation Options: A text field containing "-i" and a "Change..." button.
 - Archive Data
- Generate FA/Control Status Messages
- Obtain IDOC# from USBUF
- Obtain IDOC# from Doc Ref Number
- Offset: 0 (with a small dropdown arrow) From start of Doc Ref Number

At the bottom of the dialog are four buttons: "< Back", "Next >", "Cancel", and "Help".

Note

For SAP inbound:

- Standard-to-SAP flows must have at least a "-i" in the Translation Options field.
- Application-to-SAP flows must have at least a "-o" in the Translation Options field.

(Continued on next page)

Processing agent fields and functions

This table describes the fields of the Processing agent dialog box and their functions.

Field	Function
Agent Name	<p>Defines the name of the processing data manager.</p> <p>Note The system supplies a default name, which is based on the file type you selected on the Flow Identification dialog box. You can override the default name.</p>
Translation Options	Displays the currently selected translation options.
Change	<p>Displays the Translation Options dialog box.</p> <p>Reference See the Translation Options Dialog Box topic in this section.</p>
Archive Data	<p>Runs the ediarc program in the translation script. Archives the EDI-standard version of the file.</p> <p>Reference See the ediarc topic in the Command Line Programs chapter of the <i>GENTRAN:Server Technical Reference Guide</i> for more information about ediarc.</p> <p>See the Archiving Data chapter in the <i>GENTRAN:Server Application Integration User's Guide</i> for information about archiving translation data.</p>
Generate FA/Control Status Messages	Indicates that you want the SAP extension to generate Functional Acknowledgment/Control status messages.
Obtain IDOC# from USRBUF	Configures the Processing agent to look in the User Buffer field of the edihist audit record to locate the IDoc number.
Obtain IDOC# from Doc Ref Number	<p>Configures the Processing agent to extract the IDoc number from the Document Reference Number.</p> <p>Note You must also enter a value in the Offset box to indicate the position that the IDoc number occupies in the Document Reference Number.</p> <p style="text-align: right;">(Continued on next page)</p>

(Contd) Field	Function
Offset--From start of Doc Ref Number	Indicates the position that the IDoc number occupies in the Document Reference Number. This value must equal the number of characters in the Document Reference Number that precede the IDoc number. Example If the IDoc number starts in position 25 of the Document Reference Number, then enter 24 in the Offset box.

Translation Options Dialog Box

Introduction

The Translation Options dialog box enables you to set the translation options for this flow. GENTRAN:Server displays the Translation Options dialog box when you click the Translation Options Change button on the Processing agent dialog box.

Illustration

This illustration shows the Translation Options dialog box.

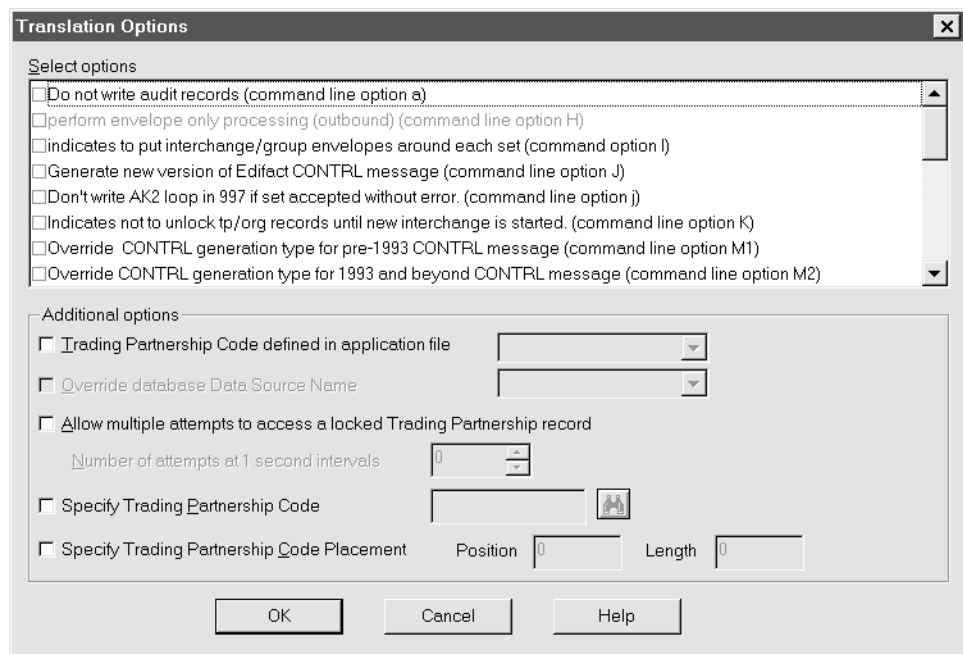

(Continued on next page)

Translation Option fields and functions

This table describes the fields of the Translation Options dialog box and their functions.

Field	Function
Select options	Enables you to select the translation options you want to apply to this flow. Reference For a complete list of translation options, see the <i>lfrtran</i> topic in the Command Line Programs chapter of the <i>GENTRAN:Server Technical Reference Guide</i> .
Trading Partnership code defined in application file	Enables you to select the application file. Used only for outbound translations.
Override database Data Source Name	For the Visual Mapper only, enables you to replace the ODBC DSN used to create the application file with the one you want to use for the current translation. Note Your GENTRAN:Server system must have the optional ODBC translation capabilities.
Allow multiple attempts to access a locked Trading Partnership record	Allows the data manager to attempt more than one time to access a locked Trading Partnership record.
Number of attempts at 1 second intervals	Enables you to specify the number of times the data manager should attempt to access a locked Trading Partnership record before translation fails.
Specify Trading Partnership Code	Enables you to search for the Trading Partnership code that you want to use to override Trading Partnership data. Used only for outbound translations.
Specify Trading Partnership Code Placement	Enables you to specify the Trading Partnership code's position in the file and the length of the code. Used only for outbound translations.

How to Set Up the Processing Agent

Introduction The processing agent in an inbound SAP flow invokes the translator.

Procedure Use this procedure to set up the processing data manager for an inbound SAP flow.

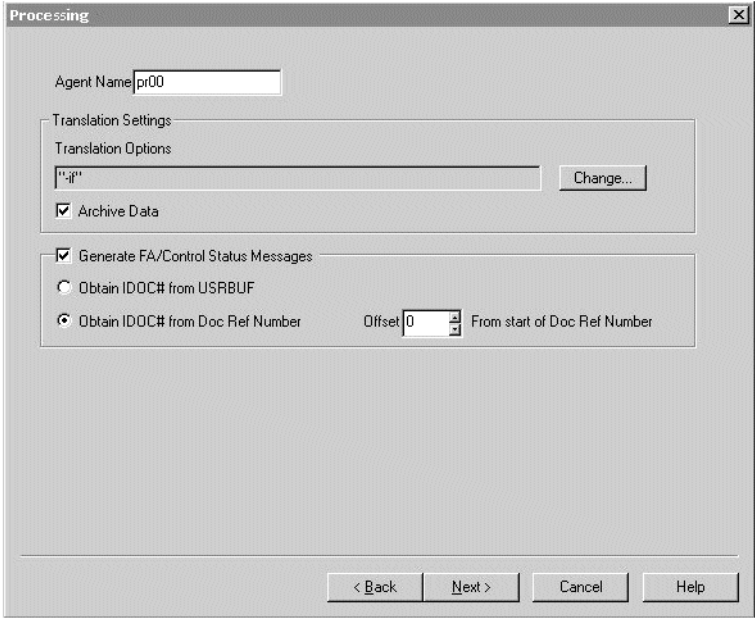
Step	Action
1	<p>Type the name of the processing data manager in the Agent Name box.</p> 
2	<p>Do you want to change the translation options?</p> <ul style="list-style-type: none"> ▶ If YES, click the Change button and complete the Translation Options dialog box. ▶ If NO, continue with Step 3. <p style="text-align: right; color: red;">(Continued on next page)</p>

(Contd) Step	Action
3	<p>Do you want the translation script to archive data?</p> <ul style="list-style-type: none"> ▶ If YES, select Archive Data and then continue with the next step. ▶ If NO, go to Step 8. <p>Note The ediarc program archives translation data.</p>
4	<p>Do you want to generate Functional Acknowledgment/Control status messages?</p> <ul style="list-style-type: none"> ▶ If YES, continue with the next step. ▶ If NO, go to Step 8.
5	<p>Have you configured your system to read the IDoc number from the User Buffer field in the audit record?</p> <ul style="list-style-type: none"> ▶ If YES, select Generate FA Status Messages and then go to Step 8. ▶ If NO, go to Step 6. <p>Reference See Generating FA Status Messages in this chapter.</p>
6	<p>Have you configured your system to include the IDoc number in the Document Reference Number?</p> <ul style="list-style-type: none"> ▶ If YES, select Obtain IDOC # from Doc Ref Number and then go to Step 7. ▶ If NO, go to Step 8.
7	<p>In the Offset box, indicate the starting position in the Document Reference Number that the IDoc number occupies. Select the number of characters offset from the first character in the Document Reference Number.</p> <p>Example If the IDoc number occupies positions 18 through 27 in the Document Reference Number, use 18 in the Offset box.</p>
8	<p>Click Next to continue to the Delivery agent dialog box.</p> <p>Reference See the How to Set Up the Delivery Agent topic in this chapter.</p>

Delivery Agent Dialog Box

Introduction

In an inbound SAP flow, the Delivery agent dialog box specifies the name of the post-processing script.

How output is routed

The delivery agent is a translation data manager. The translation script associated with the delivery agent delivers the IDocs to SAP and signals SAP to begin processing.

Delivery agent dialog box

This illustration shows the Delivery agent dialog box for an inbound SAP flow.

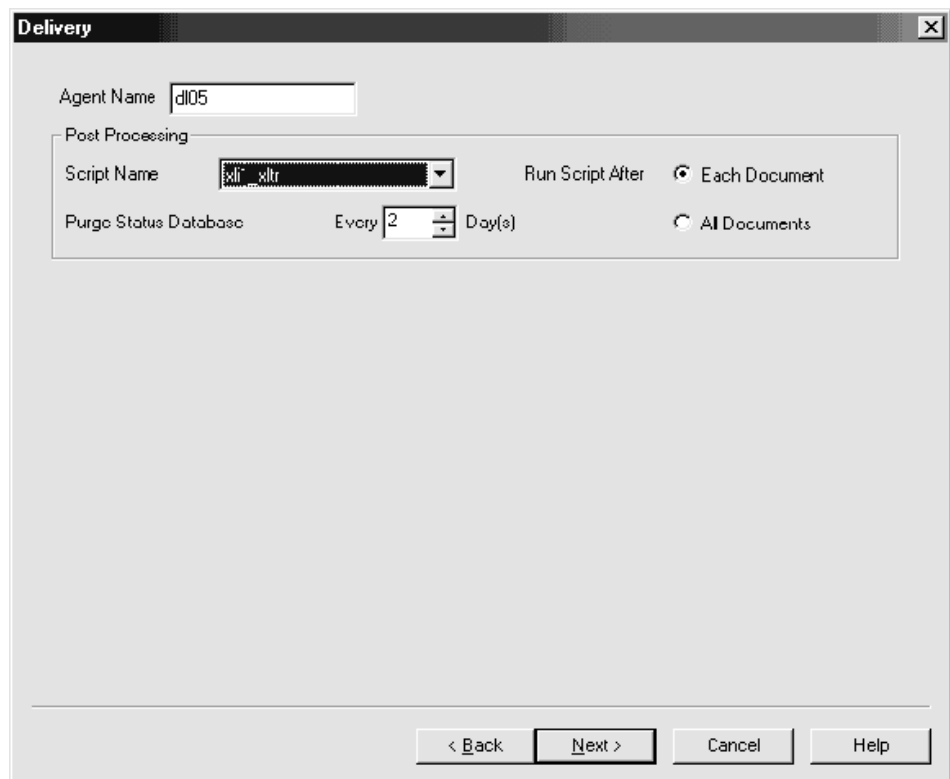

The screenshot shows a dialog box titled "Delivery" with the following fields and options:

- Agent Name:
- Post Processing section:
 - Script Name:
 - Run Script After: Each Document
 - Purge Status Database: Every Day(s) All Documents
- Buttons: < Back, Next >, Cancel, Help

(Continued on next page)

Delivery agent fields and functions

This table describes the fields of the Delivery agent dialog box for inbound SAP flows and their functions.

Field	Function
Agent Name	<p>Defines the name of the delivery data manager.</p> <p>Note The system supplies a default name. You can override the default name.</p>
Post Processing Script Name	Enables you to select the name of the script you want to run after this data manager has processed the files.
Each Document	Executes the post-processing GENTRAN:Server script after each document has been processed.
All Documents	Executes the post-processing GENTRAN:Server script after all documents have been processed.
Purge Status Database	<p>Sets the maximum age for entries in the status database. The system purges entries older than this age. The default value is 2 days.</p> <p>Notes If you generate Functional Acknowledgment or Control status messages, do not clear the status database in an application-to-SAP or SAP delayed enveloping flow.</p> <p>Set the time in this box to the longest reasonable time period for which you expect a Functional Acknowledgment or Control status message. For example, if you normally expect a Functional Acknowledgment in 24 hours, set this box to 2 or 3 days.</p>

How to Set Up the Delivery Agent

Introduction

In an inbound SAP process flow, the delivery agent runs the script that performs SAP-specific processing and IDoc delivery.

Setting configuration record information

The Delivery agent dialog box enables you to set information that the Process Control Manager uses in the Trading Partnership configuration records it creates.

You can set the:

- Agent's name
- Name of the script GENTRAN:Server runs after processing the Trading Partner's files. You also select whether the script runs after each document is processed or after all documents are processed.

(Continued on next page)

Procedure Use this procedure to set up the delivery agent for an inbound SAP flow.

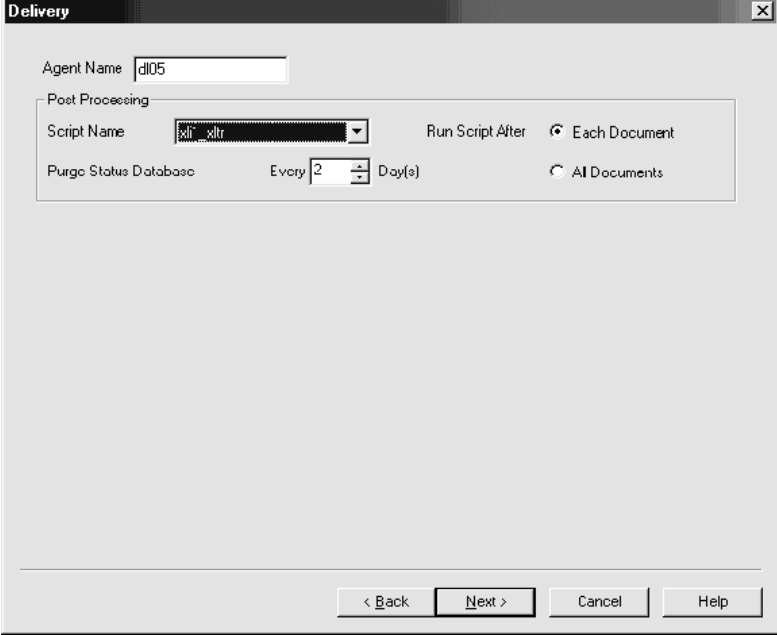
Step	Action
1	<p>Type the name of the delivery data manager in the Agent Name box.</p> 
2	<p>Do you want to execute a script after the translation process?</p> <ul style="list-style-type: none"> ▶ If YES, select the name of the script from the Script Name list and continue with Step 3. ▶ If NO, continue with Step 4. <p>Note The data files (IDocs) are no longer available to this post processing script because they have already been delivered to SAP. This is only used for non-triggering deliveries.</p>
3	<p>Click the Each document or All documents option to select when the system runs the script.</p> <p style="text-align: right; color: red;">(Continued on next page)</p>

(Contd) Step	Action
4	<p>In the Purge Status Database box, set the maximum number of days to keep entries in the status database.</p> <p>Note Set the number to the longest reasonable time period for which you expect to receive an Functional Acknowledgment or Control status message. For example, if you normally expect a Functional Acknowledgment in 24 hours, you can set the Purge Status Database box to 2 or 3 days to ensure that the database entry exists when the Functional Acknowledgment arrives.</p>
5	<p>Click Next to continue to the Error Handling dialog box.</p> <p>Reference See the Error Handling Dialog Box topic for instructions on completing the Error Handling dialog box.</p>

Completing a Flow

Overview

Introduction This section describes how to complete a process flow.

Task summary This table summarizes the tasks in completing a process flow.

Task	Description
1	Select the error handling options. Reference See How to Set Up Error Handling Instructions .
2	Select the Trading Partnership codes to use in the process flow. Reference See How to Add Trading Partnerships to the Flow .

Error Handling Dialog Box

Introduction The Error Handling dialog box defines the way in which you want errors handled. Error handling offers different options for managing error messages. You use the Error Handling dialog box to select the error handling option for each type of error.

Illustration This illustration shows the Error Handling dialog box.

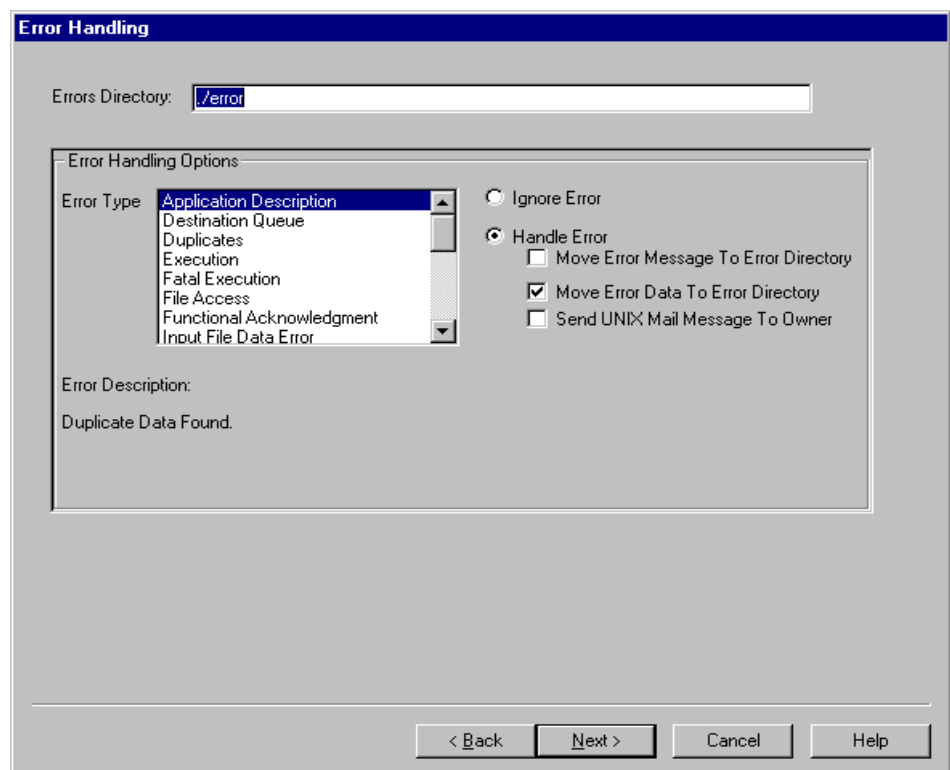

(Continued on next page)

Error Handling fields and functions

This table describes the fields of the Error Handling dialog box and their functions.

Field	Function
Error Directory	<p>Defines the name of the destination directory for errors.</p> <p>Note The default is <i>./error</i>.</p> <p>Note If the first character in the name is a forward slash then the system uses absolute path. If anything else is used the system assumes relative path.</p>
Error Type	Enables you to select a type of error so that you can specify how you want GENTRAN:Server to handle it.
Ignore Error	Turns error handling off.
Handle Error	Turns error handling on.
Move Error Message to Error directory	Routes a copy of the error message to the specified error directory.
Move Error Data To Error Directory	Routes a copy of the data that is in error to the specified error directory.
Send UNIX Mail Message To Owner	<p>Routes the error message to the name specified in the mail_proc file associated with the error type.</p> <p>Reference For instructions on how to add, edit, and delete UNIX mail_proc scripts, see the Working With UNIX Mail Scripts section in the Working With Scripts chapter in the <i>GENTRAN:Server Data Flow Administration Guide</i>.</p>

How to Set Up Error Handling Instructions

Introduction

The error handling instructions describe how the data managers deal with the various types of errors it can encounter. The Process Control Manager supports 20 different types of errors. Each error type has default handling instructions, which you can override.

Error handling options

These are your error handling options:

- ▶ Ignore the error
- ▶ Move the error message to the error directory
- ▶ Move the data that is in error to the error directory
- ▶ Move both the error message and the data that is in error to the error directory
- ▶ Send the error message to the e-mail address specified in the mail_proc file. The default is to send e-mail to the user who started the data manager.
- ▶ Move the data in error to the error directory and send the error message to the e-mail address specified in the mail_proc file.

Comment

If you are an advanced UNIX user, you can modify the mail_proc file to include the e-mail address for error messages or to make other modifications.

Reference

For instructions on how to modify the UNIX mail_proc file, see the Working With UNIX Mail Scripts section in the Working With Scripts chapter in the *GENTRAN:Server Data Flow Administration Guide*.

(Continued on next page)

Procedure Use this procedure to set up error handling instructions for the process flow.

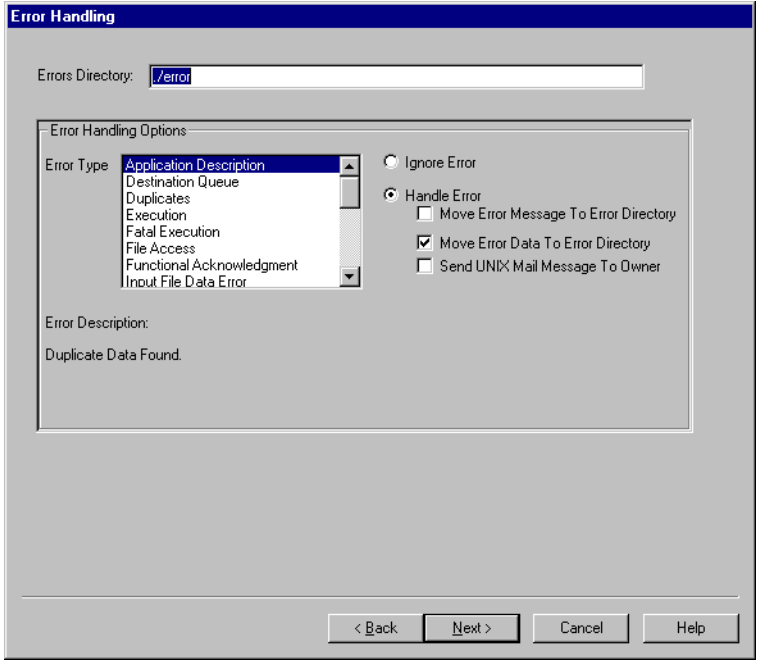
Step	Action
1	<p>Type the name of the directory to which you want errors routed.</p> 
2	Select an error type from the Error Type list.
3	<p>Do you want GENTRAN:Server to handle this type of error?</p> <ul style="list-style-type: none"> ▶ If YES, click Handle Error and then click on the way you want GENTRAN:Server to handle errors of this type: Move Error Message To Error Directory, Move Error Data to Error Directory, Send UNIX Mail Message To Owner. You can choose more than one option. ▶ If NO, click Ignore Error.
4	<p>Repeat Steps 2 and 3 until you have selected instructions for each error type. If you do not select an instruction, GENTRAN:Server uses default values</p> <p>Reference See the Maintaining Initialization Files chapter in the <i>GENTRAN:Server Data Flow Administration Guide</i> for the default values.</p> <p style="text-align: right; color: red;">(Continued on next page)</p>

(Contd) Step	Action
5	Click Next to continue to the Trading Partner Records dialog box. Reference See How to Add Trading Partnerships to the Flow .

Trading Partner Records Dialog Box

Introduction The Trading Partner Records dialog box enables you to add a list of Trading Partnership records to a process flow. This list appears blank until you add Trading Partnership records to it.

Illustration This illustration shows the Trading Partner Records dialog box. In this illustration, two Trading Partnerships have been added.

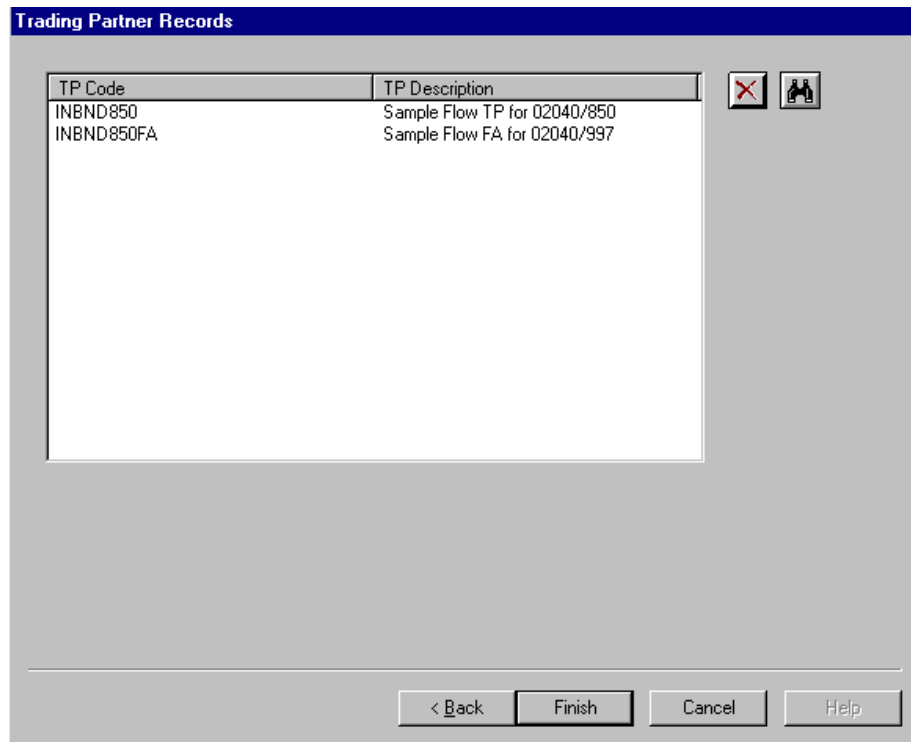

(Continued on next page)

**Trading Partner
Records dialog
box fields and
functions**

This table describes the fields of the Trading Partner Records dialog box and their functions.

Field	Function
TP Code	Lists the Trading Partnership codes of the Trading Partnership records in the flow.
TP Description	Describes the Trading Partnership record.

How to Add Trading Partnerships to the Flow

Introduction The final step in creating a process flow is to link one or more Trading Partnership records to the flow.

Purpose You link Trading Partnership records to the flow so that the Process Control Manager can generate the configuration records. A configuration record describes how a data manager directs the data that it handles for a particular Trading Partnership code or file name.

References

For more information about configuration records, see Working with Configuration Records chapter in the *GENTRAN:Server Data Flow Administration Guide*.

For information about Trading Partnership records, see the *GENTRAN:Server Application Integration User's Guide*.

Adding Trading Partnerships

Use this procedure to add a Trading Partnership record to the process flow.

Step	Action
1	<p>Click on the search icon.</p> <div style="text-align: center;">  </div> <p>System Response GENTRAN:Server displays the Trading Partner Search dialog box.</p>
2	<p>Search for the Trading Partnership code that you want to link to the flow.</p> <p>Reference See the Working With Trading Partnerships chapter in the <i>GENTRAN:Server Application Integration User's Guide</i> for instructions on using the Trading Partner Search dialog box.</p> <p>System Response GENTRAN:Server displays the Trading Partner Search Results dialog box. This dialog box lists the Trading Partnership records that match the criteria you entered.</p> <p style="text-align: right; color: red;">(Continued on next page)</p>

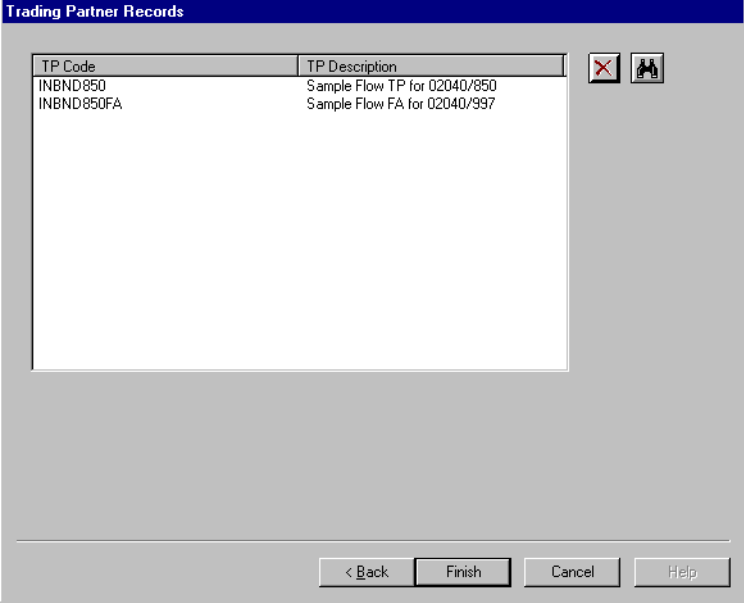
(Contd) Step	Action
<p>3</p>	<p>Select the Trading Partnerships that you want to link to the flow and then click OK.</p> <p>System Response GENTRAN:Server adds the Trading Partnerships to the flow and lists the codes and descriptions in the Trading Partner Records dialog box.</p> 
<p>4</p>	<p>Click Finish to save the new flow.</p>

Configuring an Inbound Route to SAP

Overview

Introduction

The SAP Route Configuration program is designed to configure properties of the GENTRAN:Server Extension for SAP R/3. This program enables you to configure routing properties for a SAP port and to enter trading partner cross reference information. This information is stored on the UNIX host machine. The host-based programs and the GENTRAN:Server intelligent agents use routing information.

SAP configuration dialog box

This illustration shows the SAP Configuration dialog box.

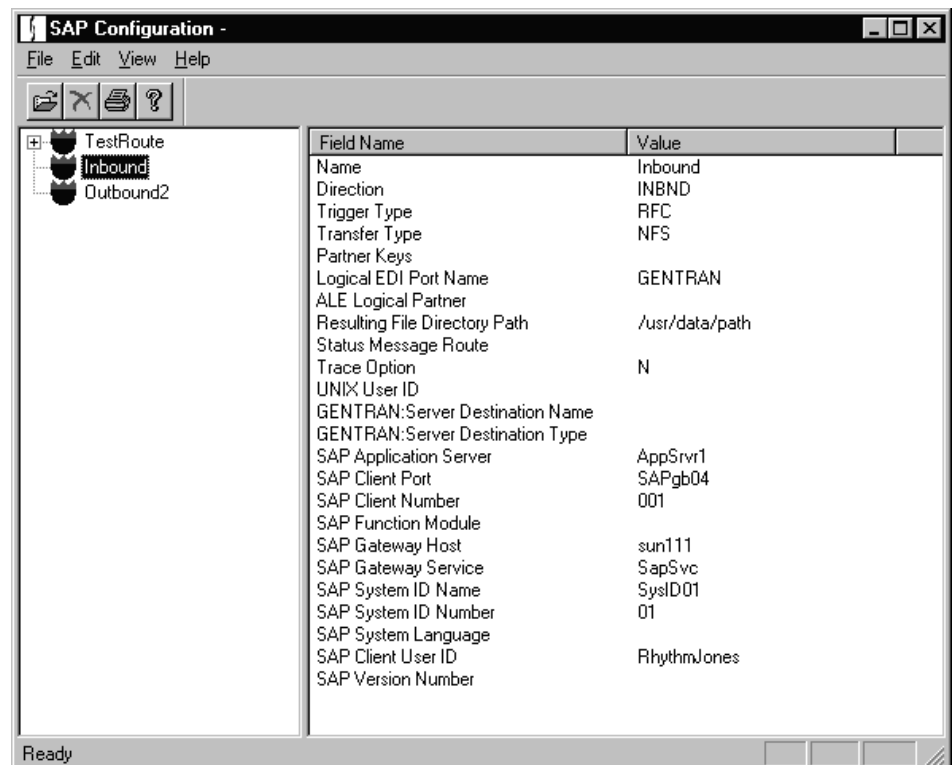

(Continued on next page)

**SAP
configuration
dialog box field
and function**

This table describes the two panes in the SAP Configuration dialog box and their function.

Field	Function
Left Pane	Identifies the list of SAP routes and their attached trading partner cross reference records.
Right Pane	Identifies the fields and values associated with the highlighted SAP route.
Field Name	Identifies the name of the trading partner cross reference records, and the inbound and outbound records.
Value	Identifies the assigned property sheet values.

Creating Routes

To create a route, you will fill out dialog boxes and assign values based on the direction of the flow for inbound and outbound directions. An SAP route can have three directions:

- Inbound
- Outbound
- Both Inbound and Outbound

Reference

For more information on the process flows see [Extension Processing](#) in this guide.

(Continued on next page)

Routing configuration dialog box

This illustration shows the Routing Configuration dialog box.

Routing configuration field and function

This table describes the fields of the Routing Configuration dialog box and their function.

Field	Function
Route Name	Identifies the name of the route for your trading partner. Note After the route is created, only trigger type and file transfer type fields can be changed on this dialog box.
Route Direction	Identifies the direction of the route you chose on the New Routing Configuration dialog box Available directions are: <ul style="list-style-type: none"> ▶ Inbound Route ▶ Outbound Route ▶ Both Inbound and Outbound Note After the route is created, only trigger type and file transfer type fields can be changed on this dialog box. (Continued on next page)

(Contd) Field	Function
Trigger Type	Identifies the trigger type. Available Types include: <ul style="list-style-type: none">▶ None▶ RFC▶ ALE Note Your trigger type selection on this dialog box determines the fields that are available on subsequent dialog boxes.
File Transfer Type	Identifies the file transfer type. Available Types include: <ul style="list-style-type: none">▶ File▶ RCP▶ ALE▶ NFS Note Your file transfer type selection on this dialog box determines the fields that are available on subsequent dialog boxes.

(Continued on next page)

Inbound Properties dialog box

This illustration shows the Inbound Properties dialog box.

Inbound Properties fields and functions

This table describes the fields of the Inbound Properties dialog box and their function.

Field	Function
SAP System ID Name	SAP R/3 System ID. This is displayed in system bar in SAP.
SAP System ID Number	Two-digit system ID (TCP/IP service). On the SM51 screen, the system ID is the third part of the system name field.
User Name	Identifies the SAP system user ID that GENTRAN:Server will use for IDoc delivery.
User Password	Identifies the SAP user ID password that GENTRAN:Server uses.
Confirm Password	Identifies that the User Password for GENTRAN:Server is correct.
SAP Client Number	SAP client as contained in the MANDT field of the control record of the IDOC.
SAP System Language	SAP R/3 language.

(Continued on next page)

(Contd) Field	Function
SAP Application Server	Application server host name. On the SM51 screen, the application server host name is the first part of the system name field.
Destination File Path	Defines the files' final destination for file-based triggering.
SAP Gateway Host	<p>Gateway Host. Can be found in SAP with the following steps:</p> <ol style="list-style-type: none"> 1. Call up SE38. 2. Enter the report name RSPARAM. 3. Choose Execute and do not select the field <i>Display also unsubstituted?</i> 4. Choose <i>Find</i>. 5. Enter <i>rdisp/sna_g</i> and confirm. 6. The name of the gateway host is displayed in the line <i>rdisp/sna_gateway</i>. <p>This field is optional. If you leave the field blank, the system assumes that gateway server host is the same host as the application server.</p>
SAP Gateway Service	<p>Gateway service entry in <i>/etc/services</i> on the GENTRAN:Server host.</p> <p>You can find the value within SAP as follows:</p> <ol style="list-style-type: none"> 1. Repeat steps 1 through 5 for the gateway host parameter above. 2. The name of the gateway service is displayed in the line <i>rdisp/sna_gw_service</i>. <p>This field is optional. If you leave the field blank, the gateway service is derived from the two-digit system ID in the form <i>sapgw<system ID></i>.</p>
SAP Port Name	<p>Logical name of the SAP system, typically <i>SAP<SAP System Name></i>. This is used to fill in the RCVPOR field in the EDI_DC header record on documents inbound to SAP.</p> <p>For outbound documents, this field along with the EDI Port Name are used as the keys to look up the outbound route.</p> <p style="text-align: right; color: red;">(Continued on next page)</p>

(Contd) Field	Function
SAP RFC Path	Directory to deposit IDocs into on the SAP host. Note This is the name of the directory only (the file name is not given here).
UNIX User Id	UNIX user ID on the SAP host to use to RCP inbound IDOC files to. The RCP command is of the form: <i>rcp file <UNIX User ID> @<AppServer>/<SAP RFC Path></i>
EDI Port Name	Logical Name of the EDI Subsystem, as defined in the SAP port definition. This is used on the startRFC command line, and is the SNDPOR field in the EDI_DC in documents inbound to SAP. On outbound documents, this value along with the SAP Port Name is used as a key to determine the outbound route.
SAP Trace	If checked, writes protocol data to the file <i>dev_rfc</i> in the current directory.
SAP ALE Logical Partner Name	Used to fill in the RCVPRN field in the control record headers of ALE status messages. This should match the Partner Number field in the GENTRAN:Server Logical System Partner Profile that is set up for SYSTAT01 IDOC status messages for ALE.
SAP Function Module	Name of the function module called to upload inbound IDOC data files (not used for status messages). This is an optional field. <ul style="list-style-type: none"> ▶ If left blank, EDI_DATA_INCOMING is used for file triggering, ▶ INBOUND_IDOC_PROCESS is used for triggering of version 3 IDOCs, ▶ IDOC_INBOUND_ASYNCHRONOUS is used for triggering of version 4 IDOCs.

How to Create an Inbound Route (to SAP)

Introduction Inbound routes define a specific flow that sends information from a trading partner to an SAP host.

Procedure Use this procedure to create a new inbound route.

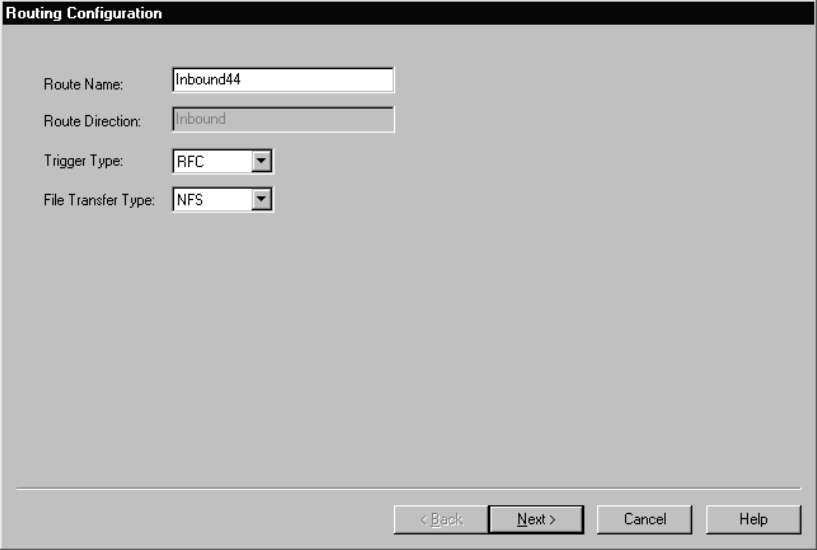
Step	Action
1	Select SAP Configuration from the GENTRAN:Server Tools menu to start the extension for SAP.
2	On the File menu, select New Routing Configuration , and then click Inbound .
3	<p>Complete the Routing Configuration dialog box.</p>  <p>Reference For more detailed information see the Routing configuration field and function table in this chapter.</p> <p style="text-align: right;">(Continued on next page)</p>

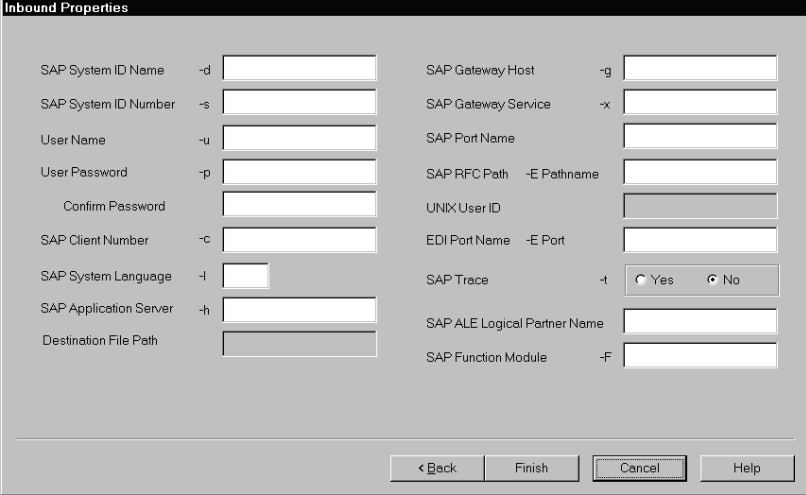
Step	Action
4	<p>Click Next.</p> <p>System Response The system displays the Inbound properties dialog box.</p> 
5	<p>Complete the Inbound Properties dialog box.</p> <p>Reference See the Inbound Properties dialog box topic for more detailed information on the Inbound Properties fields.</p>
6	<p>Click Finish to exit the Inbound Properties dialog box and return to the SAP Configuration menu.</p> <p>Your inbound route is now complete.</p>

Configuring Outbound Extension Processing

Contents	Overview	
	▶ Introduction	3
	▶ The Flow of Work	4
	▶ How to Create the Supporting Files	6
	Naming the Process Flow	
	▶ Flow Identification Dialog Box	7
	▶ How to Name and Describe the Flow	9
	Creating an Outbound SAP Flow	
	▶ Overview	11
	▶ Source Agent Dialog Box	13
	▶ How to Set Up the Source Agent	16
	▶ Processing Agent Dialog Box	18
	▶ How to Set Up the Processing Agent	20
	▶ Delivery Agent Dialog Box	21
	▶ Translation Options Dialog Box	25
	▶ How to Set Up the Delivery Agent	27
	Completing a Flow	
	▶ Overview	31
	▶ Error Handling Dialog Box	32
	▶ How to Set Up Error Handling Instructions	34
	▶ Trading Partner Records Dialog Box	37
	▶ How to Add Trading Partnerships to the Flow	39
	Configuring an Outbound Route for SAP	
	▶ Overview	41
	▶ How to Create an Outbound Route (From SAP)	47

Creating an Outbound Trading Partner Cross Reference

- ▶ Overview 48
 - ▶ How to Create a Trading Partner Cross Reference 51
-

Overview

Introduction

Introduction

To route IDoc files from SAP you need to:

- ▶ Configure outbound flow
 - ▶ Create an outbound route
 - ▶ Create trading partner cross reference
-

The Flow of Work

Task summary

This table summarizes the tasks you must complete to configure for outbound extension processing.

Task	Description
1	<p>Configure SAP to accept outbound IDocs.</p> <ul style="list-style-type: none"> ▶ Set up RFC Destination <p>Reference See Extension Triggering of this guide for more information.</p> <ul style="list-style-type: none"> ▶ Set up SAP Port Definitions ▶ Set up Partner Profile Definition <p>Reference See Chapter 1 of the <i>SAP System R/3 Release 3.0 EDI Interface Configuration Manual</i> for more information.</p>
2	<p>Set up the GENTRAN:Server outbound Trading Partnership codes.</p> <p>Reference See the Trading Partnership Code Administration chapter in the <i>GENTRAN:Server Application Integration User's Guide</i>.</p>
3	<p>Set up the GENTRAN:Server outbound Maps.</p> <p>Reference See the Designing Your Map chapter in the <i>GENTRAN:Server Application Integration User's Guide</i>.</p>
4	<p>Create the supporting files.</p> <p>Reference See How to Create the Supporting Files.</p>
5	<p>Name the new process flow.</p> <p>Reference See Naming the Process Flow.</p>
6	<p>Create the data managers (agents) for the outbound process flow.</p> <p>Reference See Creating an Outbound SAP Flow.</p>

(Continued on next page)

(Contd) Task	Description
7	Complete the process flow. Reference See Completing a Flow .
8	Set up an outbound extension route to SAP. Reference See Configuring an Outbound Route for SAP .
9	Set up the Trading Partner Cross Reference records. Reference See How to Create a Trading Partner Cross Reference .

Flow guidelines

Follow these guidelines when creating a new process flow:

- ▶ Give each flow in your system a unique name.
 - ▶ Use a unique name for each data manager in your system.
 - ▶ Use the flow description to help identify the flow.
-

How to Create the Supporting Files

Introduction Before you create a new process flow, you should create supporting files you plan to use in the process flow. These include:

- ▶ Trading Partnership records
- ▶ Trading Partnership categories
- ▶ Directories and queries

Procedure Use this procedure to create a new process flow.

Step	Action
1	Create the Trading Partnership records and categories.
2	Do you want to run a GENTRAN:Server script after files are processed? <ul style="list-style-type: none">▶ If YES, create the script and move it to the <i>./script</i> directory.▶ If NO, continue with Step 2. <p>References For instructions on creating scripts, see the Working With Scripts chapter in the <i>GENTRAN:Server Data Flow Administration Guide</i>.</p>
3	Do you want to use <i>./error</i> as the error directory? <ul style="list-style-type: none">▶ If YES, you may create your process flow.▶ If NO, create an error directory to hold error messages and erroneous data.

Naming the Process Flow

Flow Identification Dialog Box

Introduction

The Flow Identification dialog box is used to name and describe the process flow. This dialog box is the same for all flow types.

Flow Identification dialog box

This illustration shows the Flow Identification dialog box.

The screenshot shows a dialog box titled "Flow Identification". Inside the dialog, there is a section labeled "Flow Information" which contains three input fields: "Name" (a text box), "Description" (a text box), and "Type" (a dropdown menu). At the bottom of the dialog, there are four buttons: "< Back", "Next >", "Cancel", and "Help".

(Continued on next page)

**Flow
Identification
fields and
functions**

This table describes the fields of the Flow Identification dialog box and their functions.

Field	Function
Name	Defines the name of the process flow.
Description	Describes the process flow (optional).
Type	Identifies the type of process flow. <ul style="list-style-type: none">▶ Standard-to-SAP▶ Application-to-SAP▶ SAP-to-standard▶ SAP-to-application <p>Note This list may appear different in your installation.</p>

How to Name and Describe the Flow

Introduction The first step in creating a new process flow is to name the flow, describe it, and select the flow type.

Procedure Use this procedure to name and describe the process flow and to select the flow type.

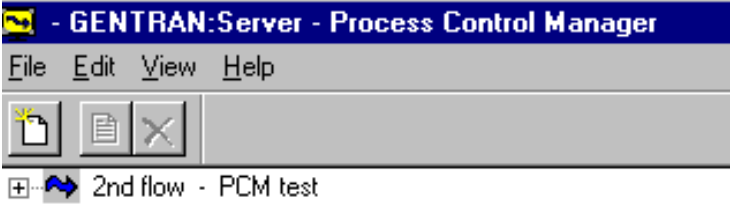
Step	Action
1	<p>Click the PCM button on the GENTRAN:Server client toolbar to start the Process Control Manager.</p>  <p>System Response GENTRAN:Server displays a tree that shows all the existing flows. This example has only one flow.</p>  <p style="text-align: right;">(Continued on next page)</p>

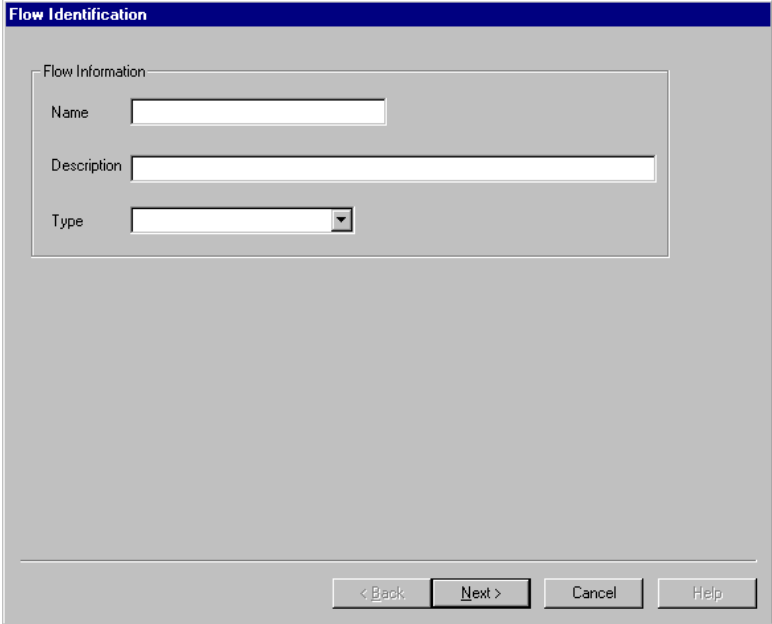
(Contd) Step	Action
2	<p>Click New on the File menu to start the wizard.</p> <p>System Response GENTRAN:Server displays the Flow Identification dialog box.</p> 
3	<p>Complete the boxes.</p> <p>Important You must name the flow and select a flow type. The description is optional, but we recommend that you include a description.</p>
4	<p>Click Next to continue to the Source Setup dialog box.</p> <p>Reference See the Source Agent Dialog Box in this chapter. See Creating an Outbound SAP Flow in this chapter.</p>

Creating an Outbound SAP Flow

Overview

Flow types These are the possible flow types for outbound SAP flows:

- ▶ SAP-to-standard
- ▶ SAP-to-application

Intelligent agents An outbound SAP flow uses the following intelligent agents:

- ▶ **SIR**
- ▶ **SIA**
- ▶ **I2E**

Routing direction This table describes the routing direction in an outbound SAP flow.

Stage	Description
1	The communications gateway detects a new document file from SAP and routes the new document file to the SIR intelligent agent.
2	The SIR intelligent agent: <ul style="list-style-type: none"> ▶ Receives the document file ▶ Uses the Trading Partner Cross Reference database to split the IDoc data into individual files by Trading Partnership code ▶ Sends status messages back to SAP ▶ Uses the file name format <TPCODE>.<MBAGID>.<UNIQID> to rename a file for each Trading Partner and routes it to the SIA intelligent agent <p style="text-align: right; color: red;">(Continued on next page)</p>

(Contd) Stage	Description
3	For each Trading Partner file, the SIA intelligent agent: <ul style="list-style-type: none">▶ Validates the IDoc information▶ Builds the document reference number▶ Sends the document file to the I2E intelligent agent
4	For each Trading Partner file, the I2E intelligent agent: <ul style="list-style-type: none">▶ Calls the translation script to translate the IDoc document file into an EDI standard format▶ Sends status messages back to SAP▶ Routes the document file to the gateway and trading partner
5	The SIR and I2E intelligent agents pass status messages to SAP.

Source Agent Dialog Box

Introduction The Source agent dialog box for an outbound SAP flow creates the data manager that starts your process flow.

Illustration This illustration shows the Source agent dialog box for an outbound SAP flow.

The screenshot shows a dialog box titled "Source" with a blue header bar. The "Agent Name" field contains "sr07". Under "New File Detection", the "Directory Scan" radio button is selected, and the "Source Directory" field is empty. Under "Scan Frequency", the "Periodically" radio button is selected, and the "Every" field is set to "0" Hour(s), "0" Minute(s), and "3" Second(s). At the bottom, there are four buttons: "< Back", "Next >", "Cancel", and "Help".

(Continued on next page)

Source agent fields and functions

This table describes the fields of the Source Setup dialog box and their functions for outbound SAP flows.

Field	Function
Agent Name	<p>Defines the name of the source data manager. The name cannot be longer than four characters (A to Z and 0 to 9).</p> <p>Note The system supplies a default name, which is based on file type selected on the Flow Identification dialog box. You can override the default name.</p>
Queue	Selects queue as the source type that the data manager scans for new file names to process.
Queue Name	Enables you to select (from the drop-down list) the name of the queue that the data manager scans for new file names. The drop-down list contains the names of all the existing queues.
Directory Scan	Selects a scan directory as the source type that the data manager scans for new files to process.
Source Directory	<p>Enables you to type or select the name of the directory that the data manager scans for new files. If you choose to type the name, use the relative path for EDI_ROOT.</p> <p>Note If the first character in the name is a forward slash, the system uses the absolute path. If anything else is used the system assumes a relative path.</p> <p>Note If the directory name does not exist, the PCM wizard displays a prompt that asks if you want to create the directory.</p>
Once	Selects one time as the scan frequency.
Periodically	Enables you to select the frequency with which you want the source data manager to scan its source directory or queue.

(Continued on next page)

(Contd) Field	Function
Hour(s)	Defines, in hours, the frequency with which the data manager scans for new files.
Minute(s)	Defines, in minutes, the frequency with which the data manager scans for new files.
Second(s)	Defines, in seconds, the frequency with which the data manager scans for new files. The default value is 3 seconds.

How to Set Up the Source Agent

Introduction The source agent starts a process flow. In an outbound SAP flow, the source agent runs an embedded script that is designed to process SAP data.

Procedure Use this procedure to set up the source agent.

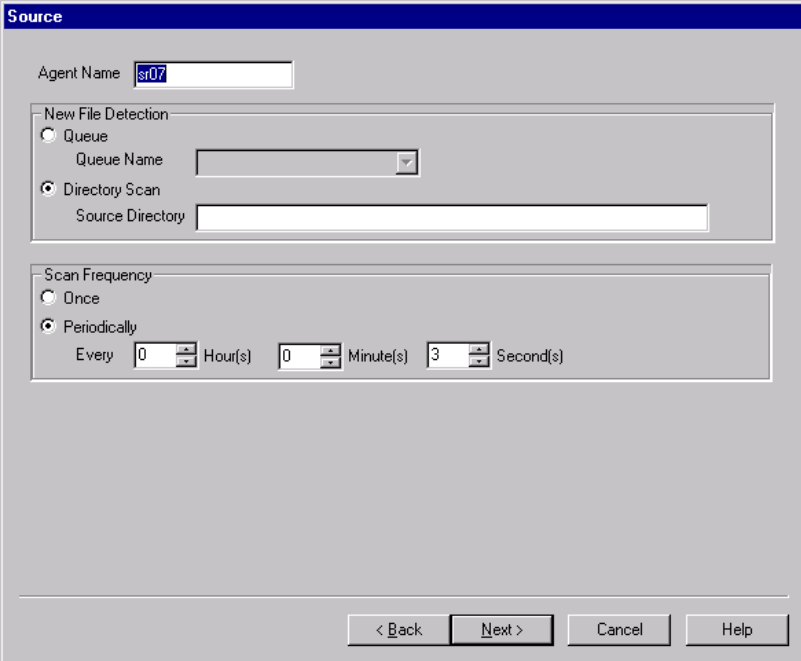
Step	Action
1	<p>Type the name of the source agent in the Agent Name box.</p> <p>Comment GENTRAN:Server supplies a default name. You can override the name.</p> 
2	<p>Select either Queue or Directory Scan as the type of source that you want the source agent to examines for data to process.</p> <p style="text-align: right; color: red;">(Continued on next page)</p>

(Contd) Step	Action
3	<p>Is the source a queue?</p> <ul style="list-style-type: none">▶ If YES, select the name of the queue from the drop-down list.▶ If NO, (the source is a directory), type the relative path name to the directory in the text box. <p>Note If the directory name does not exist, the PCM wizard displays a prompt that asks if you want to create the directory.</p>
4	<p>Click Once or Periodically to select the scan frequency.</p> <p>Note The scan frequency you select applies to every data manager in the flow.</p>
5	<p>Did you select Periodically in Step 4?</p> <ul style="list-style-type: none">▶ If YES, complete the Hour(s), Minute(s) and Second(s) boxes to select the frequency with which the data manager awakens and scans the queue or directory.▶ If NO, continue with Step 6.
6	<p>Click Next to continue to the Processing Agent dialog box.</p> <p>Reference See How to Set Up the Processing Agent.</p>

Processing Agent Dialog Box

Introduction

The Processing agent dialog box in an outbound SAP flow splits files by group or document.

Processing agent dialog box

This illustration shows the Processing agent dialog box for outbound SAP flows.

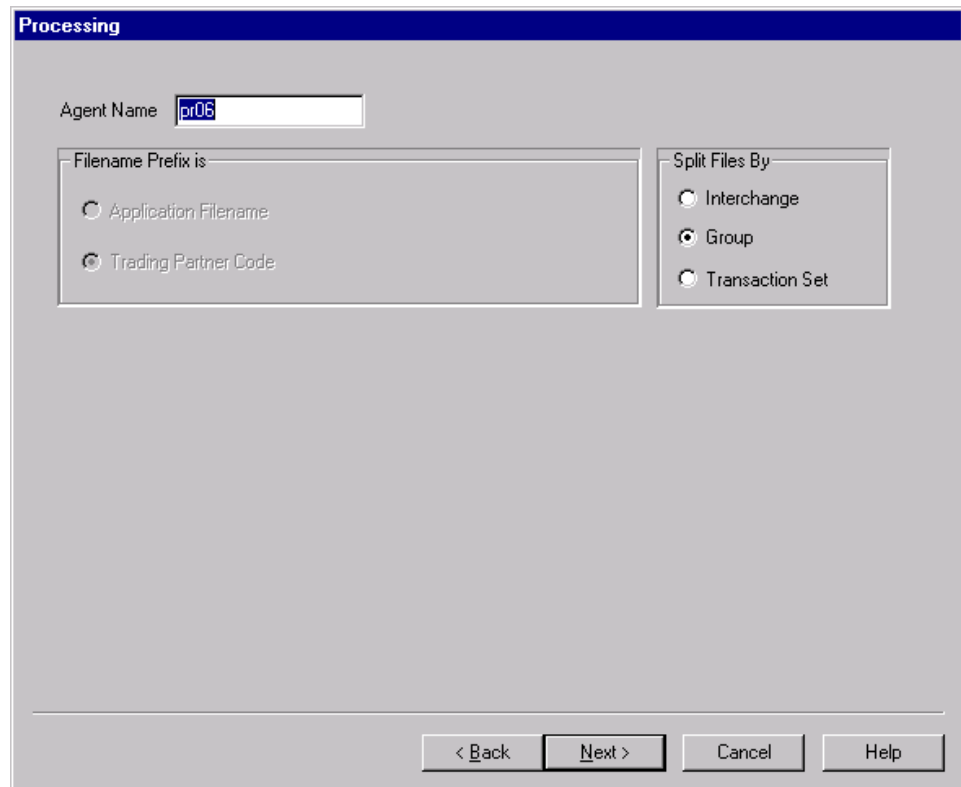

The screenshot shows a dialog box titled "Processing". It contains the following elements:

- An "Agent Name" text box containing the value "pr06".
- A "Filename Prefix is" section with two radio button options:
 - Application Filename
 - Trading Partner Code
- A "Split Files By" section with three radio button options:
 - Interchange
 - Group
 - Transaction Set
- Navigation buttons at the bottom: "< Back", "Next >", "Cancel", and "Help".

(Continued on next page)

**Processing
agent fields and
functions**

This table describes the fields of the Processing Agent dialog box for outbound SAP flows and their functions.

Field	Function
Agent Name	Defines the name of the processing data manager. Note The system supplies a default name, which is based on file type you selected on the Flow Identification dialog box. You can override the default name.
Application Filename	Indicates that, if the file name prefix exists, then the application description file name is the prefix. Otherwise, the application description file name is the entire file name.
Trading Partner Code	Indicates that, if the input file name prefix exists, then the Trading Partnership code is the prefix. If the prefix does not exist, then the Trading Partnership code is the entire file name. This is the GENTRAN:Server extension for SAP default.
Interchange	Selects interchange as the splitting method to route files.
Group	Selects group as the splitting method to route files. This is the default option.
Transaction Set	Selects transaction set as the splitting method to route files.

How to Set Up the Processing Agent

Introduction In an outbound SAP flow, the processing agent receives and processes the files that the source agent's translation script produced.

Procedure Use this procedure to set up the processing agent.

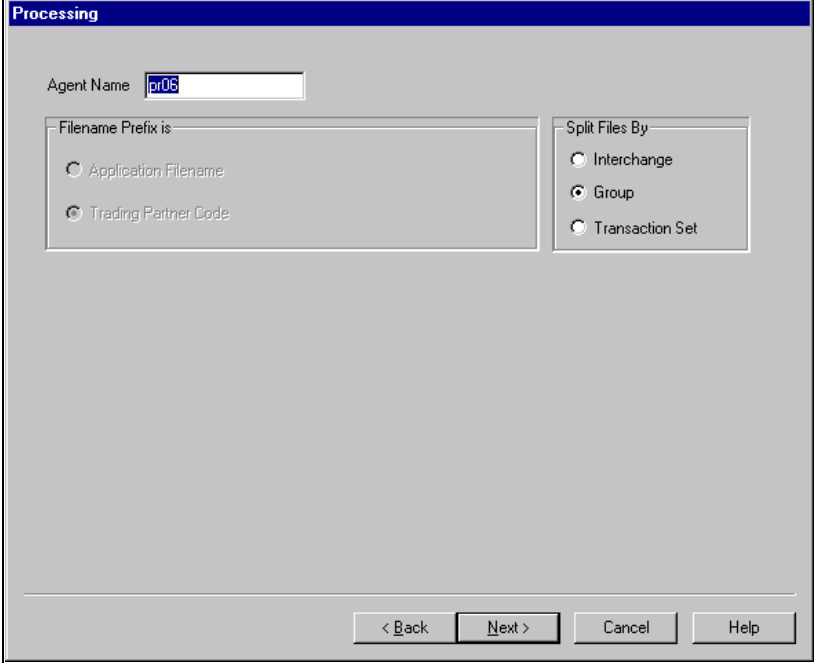
Step	Action
1	<p>Type the name of the processing data manager in the Agent Name box.</p> 
2	Click Interchange , Group , or Transaction Set to select how the data manager groups routed data.
3	<p>Click Next to continue to the Delivery Agent dialog box.</p> <p>Reference See How to Set Up the Delivery Agent.</p>

Delivery Agent Dialog Box

Introduction

In an outbound SAP flow, the Delivery agent dialog box:

- Specifies the translation options
- Archives translation data
- Designates the name of the results (output) directory and file name
- Specifies the name of the post processing script (if any) and selects when the script is run.

Delivery agent dialog box

This illustration shows the Delivery agent dialog box.

The screenshot shows a dialog box titled "Delivery" with the following fields and options:

- Agent Name: dl02
- Translation Settings:
 - Translation Options: "-ofxs" (with a "Change..." button)
 - Archive Data:
 - Clear Status Database:
- Results Directory:
 - Queue Output: (with a file selector)
 - Set Type:
 - TP Code:
 - Categories: (with a file selector)
 - User-Defined: (with a text field)
- Results File:
 - Set Type:
 - TP Code: (with a file selector)
 - User-Defined: (with a text field)
 - Categories: (with a file selector)
- Post Processing:
 - Script Name: (with a dropdown menu)
 - Run Script After: Each Document, All Documents

Buttons at the bottom: < Back, Next >, Cancel, Help

(Continued on next page)

Delivery agent fields and functions

This table describes the fields of the Delivery agent dialog box for outbound SAP flows and their functions.

Field	Function
Agent Name	<p>Defines the name of the processing data manager.</p> <p>Note The system supplies a default name, which is based on file type you selected on the Flow Identification dialog box. You can override the default name.</p>
Translation Settings	
Translation Options	Displays the currently selected translation options.
Change	<p>Displays the Translation Options dialog box.</p> <p>Reference See the Translation Options Dialog Box topic in this section.</p>
Archive Data	<p>Runs the ediarc program in the translation script. Archives the EDI-standard version of the file, whether inbound or outbound.</p> <p>Reference See the ediarc topic in the Command Line Programs chapter of the <i>GENTRAN:Server Technical Reference Guide</i> for more information about ediarc.</p> <p>See the Archiving Data chapter in the <i>GENTRAN:Server Application Integration User's Guide</i> for information about archiving translation data.</p>
Clear Status Database	<p>Enables you to send status messages on Functional Acknowledgments.</p> <p style="text-align: right;">(Continued on next page)</p>

(Contd) Field	Function
Results Directory	
Queue Output	<p>Enables you to select a queue as the destination for translation output. When you select a queue the cursor moves to the Results Directory box. You must specify a destination directory.</p> <p>Note You can use the drop-down list box to select the name of the queue from the host to which you are connected.</p>
Set Type	<p>Selects transaction set type as the symbolic value for the destination directory in the configuration records. The Process Control Manager substitutes the actual value for the type of transaction set in the configuration records.</p>
TP Code	<p>Selects Trading Partnership code as the destination directory in the configuration records.</p> <p>The Process Control Manager substitutes the actual Trading Partnership code in the configuration records.</p>
Categories	<p>Enables you to specify a Trading Partnership category as the destination directory or file name in the configuration records.</p> <p>You can select the category from the drop-down list box that is below the Categories option.</p> <p>The Process Control Manager substitutes the actual category value in the configuration records.</p>
User-Defined	<p>Enables you to specify the destination directory for the configuration records.</p> <p>You can enter the path in the text box that is below the User Defined option.</p> <p style="text-align: right; color: red;">(Continued on next page)</p>

(Contd) Field	Function
Results File	
Set Type	Selects transaction set type as the symbolic value for the destination file name in the configuration records. The Process Control Manager substitutes the actual value for the type of transaction set in the configuration records.
User-Defined	Enables you to specify the destination file name for the configuration records. You can enter the path in the text box that is below the User Defined option.
TP Code	Selects Trading Partnership code as the destination file name in the configuration records. The Process Control Manager substitutes the actual Trading Partnership code in the configuration records.
Categories	Enables you to specify a Trading Partnership category as the destination file name in the configuration records. You can select the category from the drop-down list box that is below the Categories option. The Process Control Manager substitutes the actual category value in the configuration records.
Post-Processing	
Script Name	Enables you to enter or select the name of the script you want to run after this data manager has processed the files.
Each Document	Executes the post-processing GENTRAN:Server script after each document has been processed.
All Documents	Executes the post-processing GENTRAN:Server script after all documents have been processed.

Translation Options Dialog Box

Introduction The Translation Options dialog box enables you to set the same translation options this flow. GENTRAN:Server displays the Translation Options dialog box when you click the Translation Options Change button on the Delivery Agent dialog box.

Illustration This illustration shows the Translation Options dialog box.

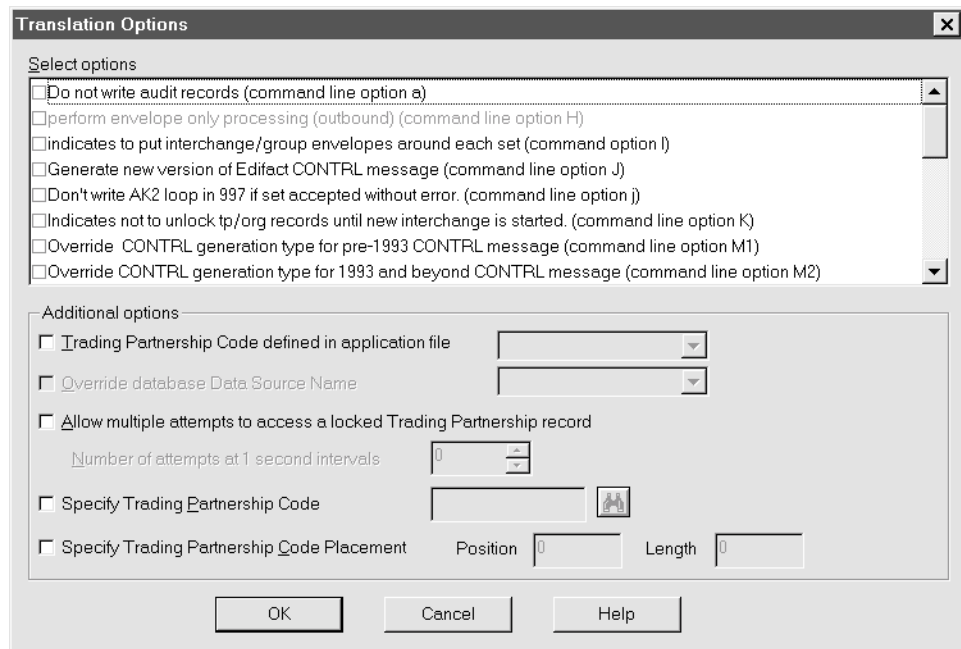

(Continued on next page)

Translation Options fields and functions

This table describes the fields of the Translation Options dialog box and their functions.

Field	Function
Select options	Enables you to select the translation options you want to apply to this flow. Reference For a complete list of translation options, see the lfrtran topic in the Command Line Programs chapter of the <i>GENTRAN:Server Technical Reference Guide</i> .
Trading Partnership code defined in application file	Enables you to select the application file. Used only for outbound translations.
Override database Data Source Name	For the Visual Mapper only, enables you to replace the ODBC DSN used to create the application file with the one you want to use for the current translation. Note Your GENTRAN:Server system must have the optional ODBC translation capabilities.
Allow multiple attempts to access a locked Trading Partnership record	Allows the data manager to attempt more than one time to access a locked Trading Partnership record.
Number of attempts at 1 second intervals	Enables you to specify the number of times the data manager should attempt to access a locked Trading Partnership record before translation fails.
Specify Trading Partnership Code	Enables you to search for the Trading Partnership code that you want to use to override Trading Partnership data. Used only for outbound translations.
Specify Trading Partnership Code Placement	Enables you to specify the Trading Partnership code's position in the file and the length of the of the code. Used only for outbound translations.

How to Set Up the Delivery Agent

Introduction

The delivery agent determines the destination in a process flow. In an outbound SAP flow, the delivery agent is a translator data manager.

Setting configuration record information

The Delivery Agent dialog box enables you to set information that the Process Control Manager uses in the Trading Partnership configuration records it creates.

You can set:

- ▶ Translation options that override the global settings in your mapping and translation files
- ▶ A flag to archive translation data
- ▶ Exact destination directory and file name information that you want the Process Control Manager to use in every configuration record that it creates for the flow
- ▶ Symbolic destination directory and file name values, such as a category or Trading Partnership code. The Process Control Manager substitutes the actual value for the symbolic value in the configuration records.
- ▶ The name of the script GENTRAN:Server runs after processing the Trading Partner's files. You also select whether the script runs after each document is processed or after all documents are processed.

(Continued on next page)

Procedure Use this procedure to set up the delivery data manager in an outbound SAP flow.

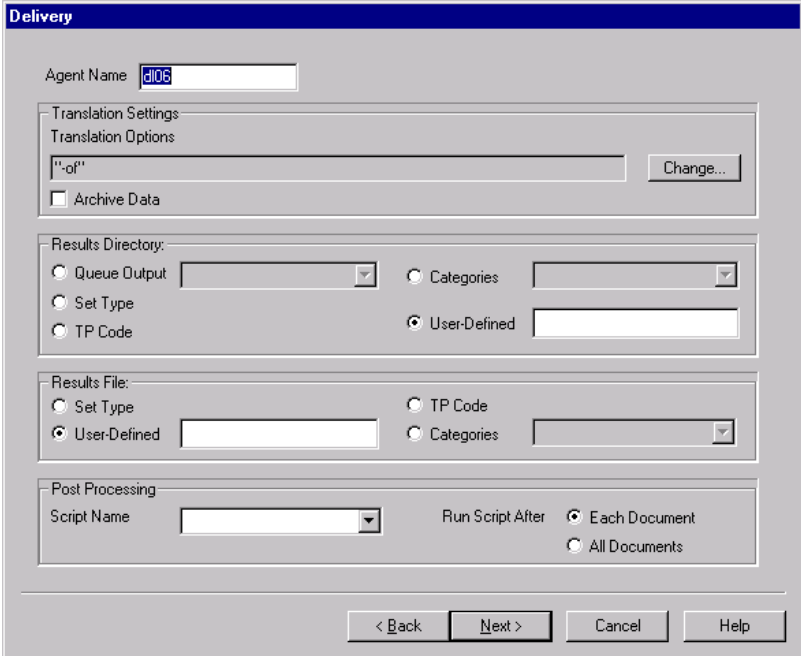
Step	Action
1	<p>Type the name of the delivery data manager in the Agent Name box.</p> 
2	<p>Do you want the translation script to Archive Data?</p> <ul style="list-style-type: none"> ▶ If YES, select Archive Data. ▶ If NO, continue with Step 3. <p>Note The ediarc program archives translation data.</p>
3	<p>Do you want to direct the translation output to a queue?</p> <ul style="list-style-type: none"> ▶ If YES, click Queue Output and select the queue from the list. ▶ If NO, continue with Step 4. <p style="text-align: right; color: red;">(Continued on next page)</p>

(Contd) Step	Action
4	<p>Choose the Results Directory by clicking Set Type, TP Code, Categories, or User-Defined to select the symbolic destination directory, or type the path to the directory for the translation output.</p> <p>Comment The Process Control Manager substitutes the actual value for the symbolic value when it creates the configuration records.</p> <p>Example If you select TP Code, the Process Control Manager uses the actual Trading Partnership code as the destination directory in the configuration records.</p>
5	<p>Did you select Categories in Step 4?</p> <ul style="list-style-type: none"> ▶ If YES, select a category from the list. ▶ If NO, continue with Step 6.
6	<p>Did you select User-Defined in Step 4?</p> <ul style="list-style-type: none"> ▶ If YES, type the path to the directory in the text box that is below the User-Defined option. ▶ If NO, continue with Step 7.
7	<p>Choose the Results File name by clicking Set Type, TP Code, Categories, or User-Defined to select the symbolic destination file name.</p> <p>Comment The Process Control Manager substitutes the actual value for the symbolic value when it creates the configuration records.</p> <p>Example If you select TP Code, the Process Control Manager uses the actual Trading Partnership code as the destination directory in the configuration records.</p>
8	<p>Did you select Categories in Step 7?</p> <ul style="list-style-type: none"> ▶ If YES, select a category from the list and continue with Step 9. ▶ If NO, continue with Step 9.
9	<p>Did you select User-Defined in Step 7?</p> <ul style="list-style-type: none"> ▶ If YES, type the complete file name in the text box that is below the User-Defined option and continue with Step 10. ▶ If NO, continue with Step 10. <p style="text-align: right; color: red;">(Continued on next page)</p>

(Contd) Step	Action
10	Do you want to execute a script after the translation process? <ul style="list-style-type: none">▶ If YES, select the name of the script from the Script Name list and continue with Step 11.▶ If NO, continue with Step 11.
11	Click the Each document or All documents option to select when the system runs the script.
12	Click Next to continue to the Error Handling dialog box. Reference See the section Completing a Flow for instructions on completing the Error Handling dialog box.

Completing a Flow

Overview

Introduction This section describes how to complete a process flow.

Task summary This table summarizes the tasks in completing a process flow.

Task	Description
1	Select the error handling options. Reference See How to Set Up Error Handling Instructions .
2	Select the Trading Partnership codes to use in the process flow. Reference See How to Add Trading Partnerships to the Flow .

Error Handling Dialog Box

Introduction The Error Handling dialog box defines the way in which you want errors handled. Error handling offers different options for managing error messages. You use the Error Handling dialog box to select the error handling option for each type of error.

Illustration This illustration shows the Error Handling dialog box.

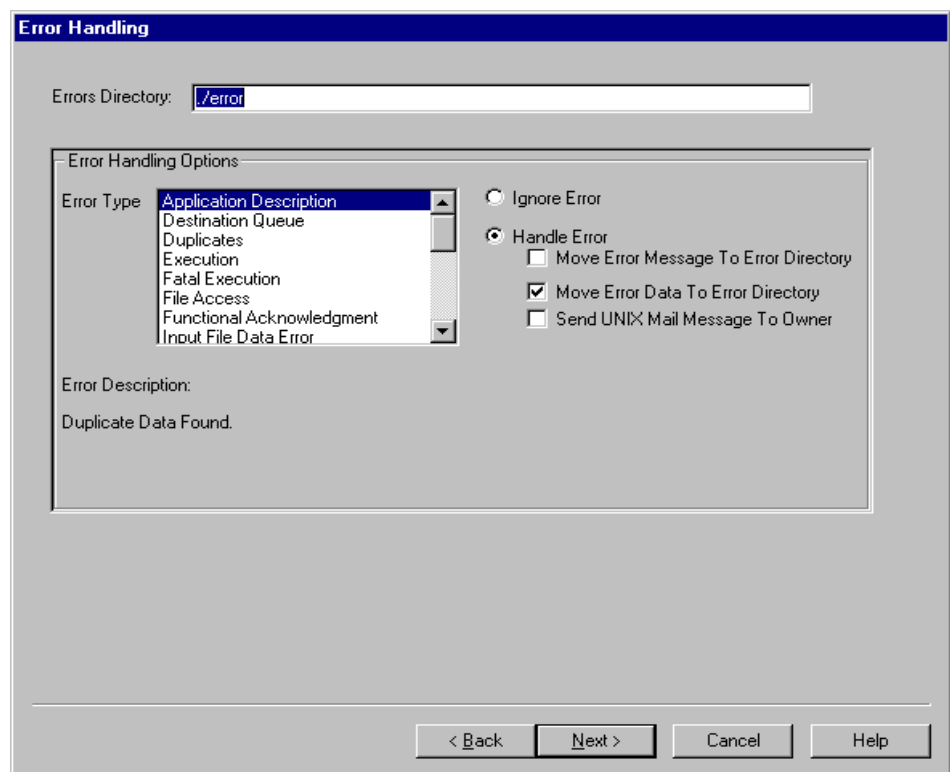

(Continued on next page)

**Error Handling
fields and
functions**

This table describes the fields of the Error Handling dialog box and their functions.

Field	Function
Error Directory	Defines the name of the destination directory for errors. Note The default is <i>./error</i> .
Error Type	Enables you to select a type of error so that you can specify how you want GENTRAN:Server to handle it.
Ignore Error	Turns error handling off.
Handle Error	Turns error handling on.
Move Error Message to Error directory	Routes a copy of the error message to the specified error directory.
Move Error Data To Error Directory	Routes a copy of the data that is in error to the specified error directory.
Send UNIX Mail Message To Owner	Routes the error message to the name specified in the mail_proc file associated with the error type. Reference For instructions on how to add, edit, and delete UNIX mail_proc scripts, see the Working With UNIX Mail Scripts section in the Working With Scripts chapter in the <i>GENTRAN:Server Data Flow Administration Guide</i> .

How to Set Up Error Handling Instructions

Introduction

The error handling instructions describe how a data manager deals with the various types of errors it can encounter. The Process Control Manager supports several different types of errors. Each error type has default handling instructions, which you can override.

Error handling options

These are your error handling options:

- ▶ Ignore the error
- ▶ Move the error message to the error directory
- ▶ Move the data that is in error to the error directory
- ▶ Move both the error message and the data that is in error to the error directory
- ▶ Send the error message to the e-mail address specified in the mail_proc file. The default is to send e-mail to the user who started the data manager.
- ▶ Move the data in error to the error directory and send the error message to the e-mail address specified in the mail_proc file.

Comment

If you are an advanced UNIX user, you can modify the mail_proc file to include the e-mail address for error messages or to make other modifications.

Reference

For instructions on how to modify the UNIX mail_proc file, see the Working With UNIX Mail Scripts section in the Working With Scripts chapter in the *GENTRAN:Server Data Flow Administration Guide*.

(Continued on next page)

Procedure Use this procedure to set up error handling instructions for the process flow.

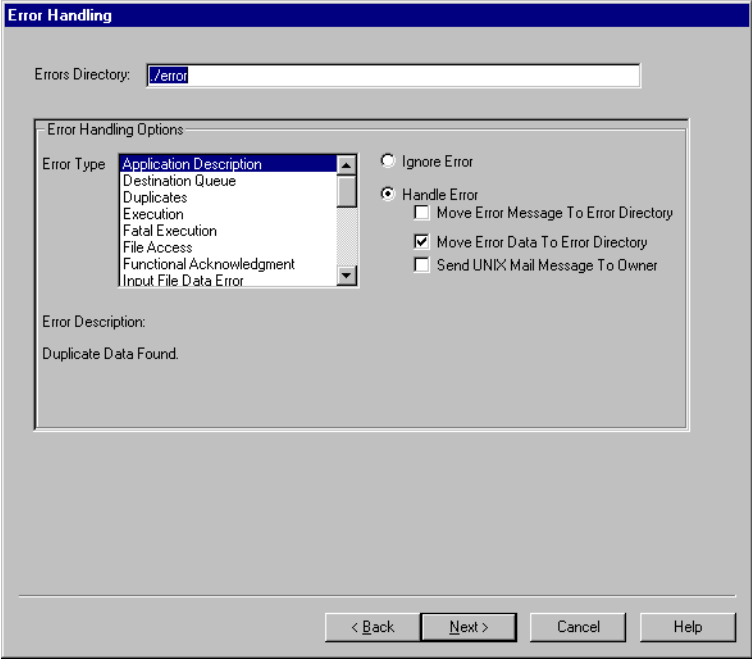
Step	Action
1	<p>Type the name of the directory to which you want errors routed.</p> 
2	<p>Select an error type from the Error Type list.</p>
3	<p>Do you want GENTRAN:Server to handle this type of error?</p> <ul style="list-style-type: none"> ▶ If YES, click Handle Error and then click on the way you want GENTRAN:Server to handle errors of this type: Move Error Message To Error Directory, Move Error Data to Error Directory, Send UNIX Mail Message To Owner. You can choose more than one option. ▶ If NO, click Ignore Error.
4	<p>Repeat Steps 2 and 3 until you have selected instructions for each error type. If you do not select an instruction, GENTRAN:Server uses default values.</p> <p>Reference See the Maintaining Initialization Files chapter in the <i>GENTRAN:Server Data Flow Administration Guide</i> for the default values.</p> <p style="text-align: right; color: red;">(Continued on next page)</p>

(Contd) Step	Action
5	Click Next to continue to the Trading Partner Records dialog box. Reference See How to Add Trading Partnerships to the Flow .

Trading Partner Records Dialog Box

Introduction The Trading Partner Records dialog box enables you to add a list of Trading Partnership records to a process flow. This list appears blank until you add Trading Partnership records to it.

Illustration This illustration shows the Trading Partner Records dialog box. In this illustration, two Trading Partnerships have been added.

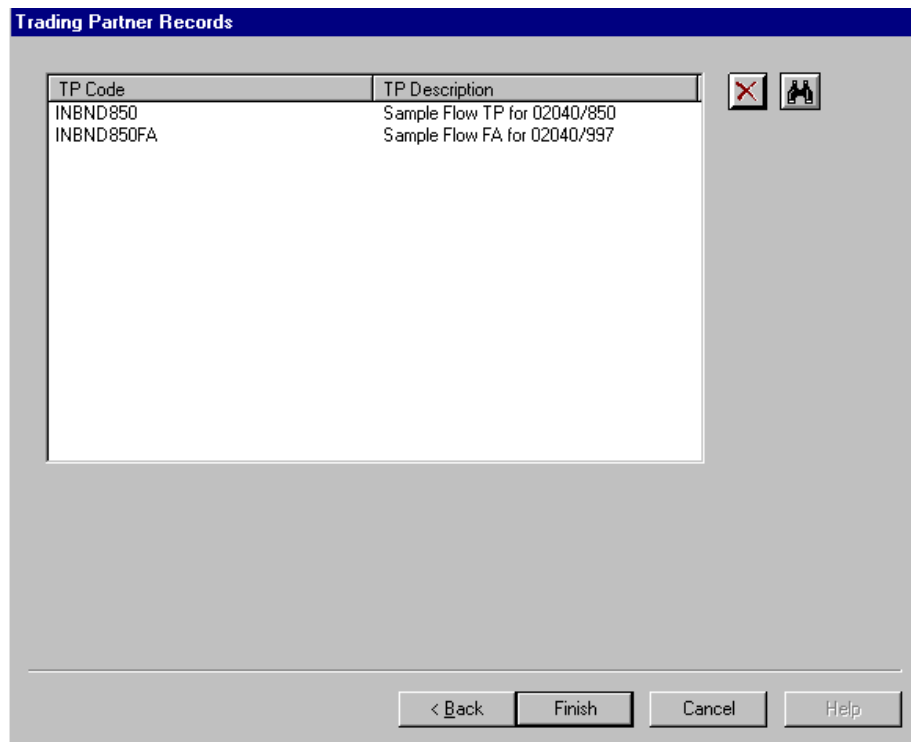

(Continued on next page)

**Trading Partner
Records dialog
box fields and
functions**

This table describes the fields of the Trading Partner Records dialog box and their functions.

Field	Function
TP Code	Lists the Trading Partnership codes of the Trading Partnership records in the flow.
TP Description	Describes the Trading Partnership record.

How to Add Trading Partnerships to the Flow

Introduction The final step in creating a process flow is to link one or more Trading Partnership records to the flow.

Purpose You link Trading Partnership records to the flow so that the Process Control Manager can generate the configuration records. A configuration record describes how a data manager directs the data that it handles for a particular Trading Partnership code or file name.

References

For more information about configuration records, see Working With Configuration Records chapter in the *GENTRAN:Server fro UNIX With EC Workbench Data Flow Administration Guide*.

For information about Trading Partnership records, see the *GENTRAN:Server Application Integration User's Guide*.

Adding Trading Partnerships

Use this procedure to add a Trading Partnership record to the process flow.

Step	Action
1	<p>Click on the search icon.</p>  <p>System Response GENTRAN:Server displays the Trading Partner Search dialog box.</p>
2	<p>Search for the Trading Partnership code that you want to link to the flow.</p> <p>Reference See the Working With Trading Partnerships chapter in the <i>GENTRAN:Server Application Integration User's Guide</i> for instructions on using the Trading Partner Search dialog box.</p> <p>System Response GENTRAN:Server displays the Trading Partner Search Results dialog box. This dialog box lists the Trading Partnership records that match the criteria you entered.</p> <p style="text-align: right;">(Continued on next page)</p>

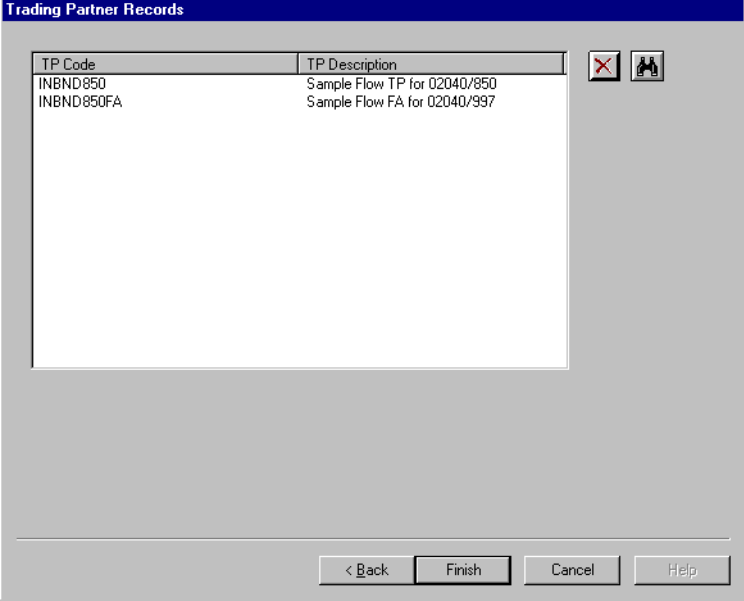
(Contd) Step	Action						
3	<p>Select the Trading Partnerships that you want to link to the flow and then click OK.</p> <p>System Response GENTRAN:Server adds the Trading Partnerships to the flow and lists the codes and descriptions in the Trading Partner Records dialog box.</p>  <table border="1"><thead><tr><th>TP Code</th><th>TP Description</th></tr></thead><tbody><tr><td>INBND850</td><td>Sample Flow TP for 02040/850</td></tr><tr><td>INBND850FA</td><td>Sample Flow FA for 02040/997</td></tr></tbody></table>	TP Code	TP Description	INBND850	Sample Flow TP for 02040/850	INBND850FA	Sample Flow FA for 02040/997
TP Code	TP Description						
INBND850	Sample Flow TP for 02040/850						
INBND850FA	Sample Flow FA for 02040/997						
4	Click Finish to save the new flow.						

Configuring an Outbound Route for SAP

Overview

Introduction

The SAP Route Configuration program configures properties of the GENTRAN:Server Extension for SAP R/3. This program enables you to configure routing properties for a SAP port and to enter trading partner cross reference information. This information is stored on the UNIX host machine. The host-based programs and the GENTRAN:Server intelligent agents use this information when they process data.

SAP configuration dialog box

This illustration shows the SAP Configuration dialog box.

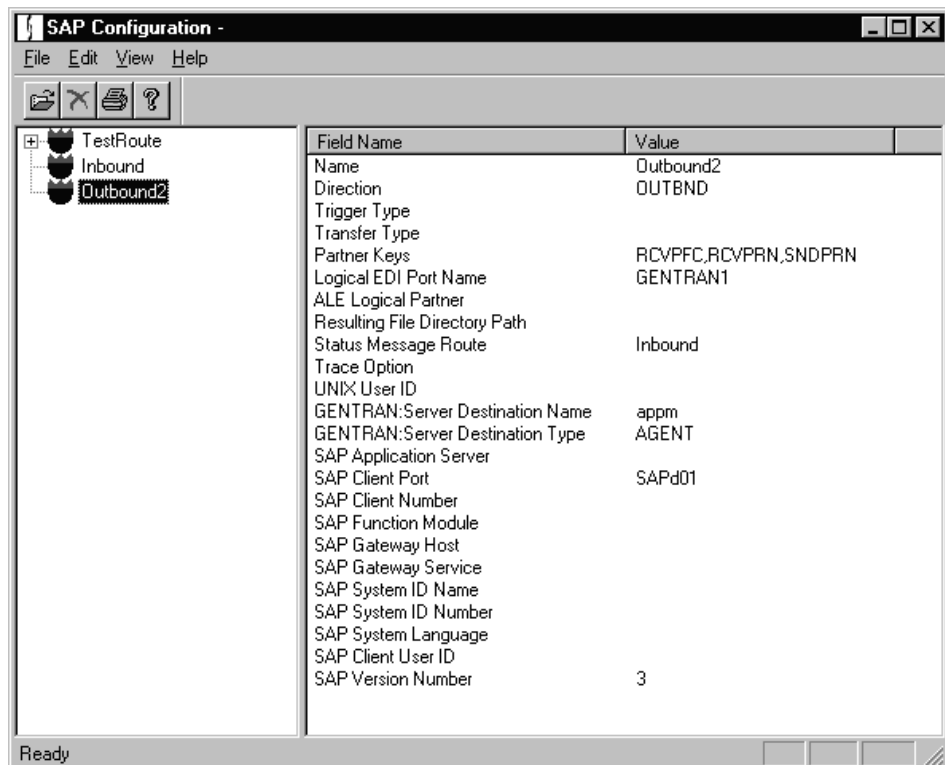

(Continued on next page)

SAP Configuration dialog box field and function

This table describes the two panes in the SAP Configuration dialog box and their function.

Field	Function
Left Pane	Identifies the list of SAP routes and their attached trading partner cross reference records.
Right Pane	Identifies the fields and values associated with the highlighted SAP route.
Field Name	Identifies the name of the trading partner cross reference records, and the inbound and outbound records.
Value	Identifies the assigned property sheet values.

Creating Routes

To create a route, you fill out dialog boxes and assign values based on the direction of the flow for inbound and outbound directions. An SAP route can have three directions:

- Inbound
- Outbound
- Both Inbound and Outbound

Reference

For more information on the process flows see the chapter [Extension Processing](#) in this guide.

(Continued on next page)

**Routing
Configuration
dialog box**

This illustration shows the Routing Configuration dialog box.

**Routing
Configuration
field and
function**

This table describes the fields of the Routing Configuration dialog box and their functions.

Field	Function
Route Name	Identifies the name of the route for your trading partner.
Route Direction	Identifies the direction of the route you chose on the New Routing Configuration dialog box. Available directions are: <ul style="list-style-type: none"> ▶ Inbound ▶ Outbound ▶ Both Inbound and Outbound

(Continued on next page)

Outbound Properties dialog box

This illustration shows the Outbound Properties dialog box.

Outbound Properties fields and functions

This table describes the fields of the Outbound Properties dialog box and their function.

Field	Function
SAP Specific	
IDoc Version	Identifies the version of SAP IDocs currently being used.
Status Message Route	Identifies the route to send status messages. Can have a separate route specified.
SAP Port Name	Identifies the name of the SAP logical system port to configure.
EDI Port Name	Identifies the name of the EDI port to configure.
SAP Destination to EDI	
By Flow	Specifies that a flow routes the IDoc. This is the flow that you create with the PCM wizard.
By Agent	Specifies that an agent routes the IDoc. This an agent that you create with the PCM wizard.

(Continued on next page)

Trading Partner Template dialog box

This illustration shows the Trading Partner Template dialog box.

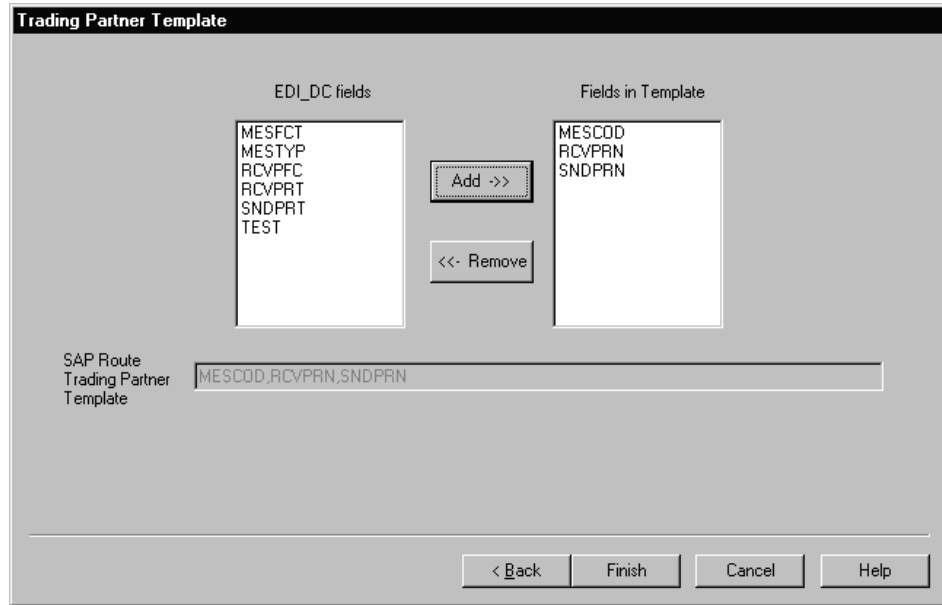

Note

This dialog box is available only when Outbound or Both Inbound and Outbound routes are selected.

Trading Partner Template field and function

This table describes the fields of the Trading Partner Template dialog box and their functions.

Field	Function
EDI_DC Fields	Lists the available fields you can use to create the trading partner template. Note The list of EDI_DC fields that are selected in a certain order make up the template that this route or port uses to identify trading partners.
Fields in Template	List the fields you selected to make up the trading partner template.
Add	Adds new EDI_DC values to the Fields in Template list.

(Continued on next page)



(Contd) Field	Function
Remove	Removes EDI_DC values from the Fields in Template list.
SAP Route Trading Partner Template	Lists the values that make up the Trading Partner Template.

Note

See [Appendix B](#) in this guide for more information on EDI_DC fields.

How to Create an Outbound Route (From SAP)

Introduction An outbound route defines a specific flow that sends information from SAP to a specific trading partner.

Procedure Use this procedure to create a new outbound route.

Step	Action
1	Select SAP Configuration from the GENTRAN:Server Tools menu to start the extension for SAP.
2	On the File menu, select Select New Routing Configuration , and then click Outbound .
3	Complete the Routing Configuration dialog box. Reference For more detailed information, see the Routing Configuration field and function table in this chapter.
4	Click Next .
5	Complete the Outbound Properties dialog box. Reference For more detailed information, see the Outbound Properties fields and functions table in this chapter.
6	Click Next .
7	Select the proper EDI_DC fields and click Add to move the selected fields to the Fields in Template list to set up the Trading Partner Template. Note Use the Remove button to move fields from the Fields in Template list to the EDI_DC fields list.
8	Click Finish to exit the Trading Partner Template dialog box and return to the SAP Configuration menu. Your Outbound route is now complete.

Creating an Outbound Trading Partner Cross Reference

Overview

Introduction

After you create a route, you must create (or attach) trading partner cross reference records to it. A trading partner cross reference record identifies the document file so that the GENTRAN:Server Extension for SAP and SAP application can route the document file through the flows. These records are used for both inbound and outbound data flows.

Source dialog box

This illustration shows the Source dialog box.

The screenshot shows a dialog box titled "Source". It contains three input fields:

- Source SAP route of IDOC: Outbound2
- Route Direction: Outbound
- GENTRAN:Server TP: Out810

At the bottom of the dialog box, there are four buttons: "< Back", "Next >", "Cancel", and "Help".

Note

The Source dialog box is the main dialog box for entering trading partner cross reference information.

(Continued on next page)

Source field and function

This table describes the fields of the Source dialog box and their function.

Field	Function
Source SAP route of IDOC	Identifies the SAP route to which the Trading Partnership records will be attached.
Route Direction	Identifies the direction of the route (Inbound or Outbound).
GENTRAN:Server TP	Identifies the GENTRAN:Server Trading Partnership code that you want to attach to this route.
	Enables you to search for the correct GENTRAN:Server TP Code.

Outbound trading partner records dialog box

This illustration shows the Outbound trading partner records dialog box.

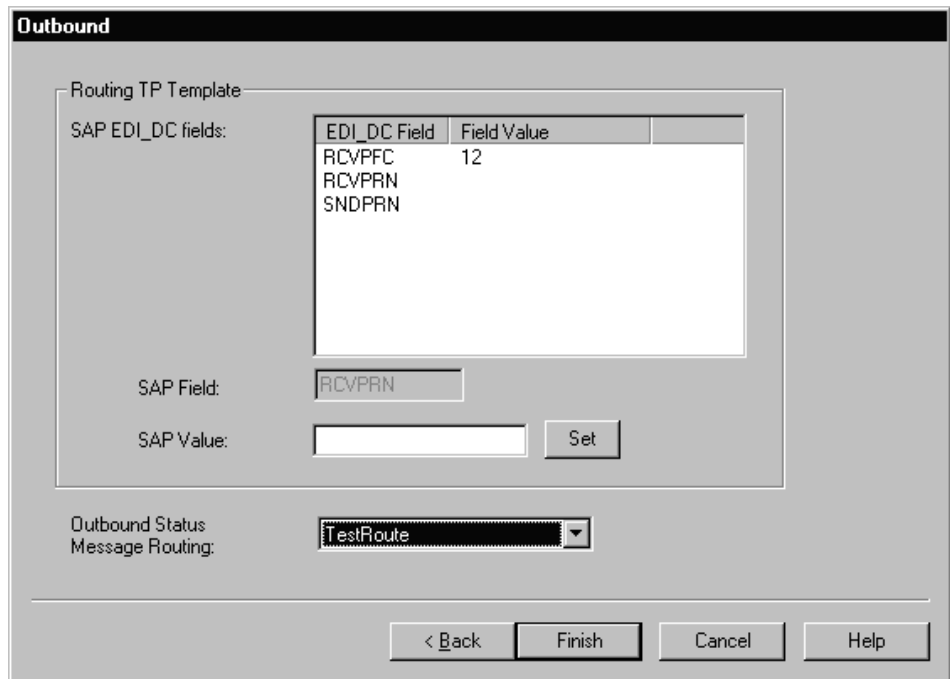

Note

The fields that are available in this list come from the route to which this trading partner record is attached to.

(Continued on next page)



Outbound trading partner records field and function

This table describes the fields of the Outbound trading partner records dialog box and their function.

Field	Function
Routing TP Template	
SAP EDI_DC Fields	Identifies the fields that make up the trading partner template.
SAP Field	Identifies the EDI_DC field selected in the Routing TP Template.
SAP Value	Defines the value of the EDI_DC field, which determines the trading partner and the associated route in an IDoc file.
Set	Saves the SAP Value and displays it under the Field Value column in this dialog box.
Outbound Status Message Routing	Identifies the route that the system will use to send status messages back to SAP.

How to Create a Trading Partner Cross Reference

Introduction A trading partner cross reference defines a specific trading partner to GENTRAN:Server.

Procedure Use this procedure to create a new trading partner cross reference.

Step	Action									
1	Select SAP Configuration from the GENTRAN:Server Tools menu to start the extension for SAP.									
2	Select New Trading Partner Cross Ref. from the File menu.									
3	Use this table to determine your next step.									
	<table border="1"> <thead> <tr> <th>IF you want to configure...</th> <th>THEN Select...</th> <th>AND complete...</th> </tr> </thead> <tbody> <tr> <td>An inbound route</td> <td>Inbound</td> <td>Step 4</td> </tr> <tr> <td>An outbound route</td> <td>Outbound</td> <td>Step 6</td> </tr> </tbody> </table>	IF you want to configure...	THEN Select...	AND complete...	An inbound route	Inbound	Step 4	An outbound route	Outbound	Step 6
	IF you want to configure...	THEN Select...	AND complete...							
	An inbound route	Inbound	Step 4							
An outbound route	Outbound	Step 6								
An inbound route	Inbound	Step 4								
An outbound route	Outbound	Step 6								
4	Complete the necessary fields in the Source dialog box.									
5	Click Finish to exit the Source dialog box and return to the SAP Configuration menu. Trading Partner Cross Reference setup for an inbound route is now complete.									
6	Complete the necessary fields in the Source dialog box.									
7	Click Next to continue to the Outbound trading partner records dialog box.									
8	In the Outbound trading partner records dialog box, complete the following: <ul style="list-style-type: none"> ▶ Select an EDI_DC field ▶ Enter a value in the SAP Value field 									
9	Click Set .									

(Continued on next page)

(Contd) Step	Action
10	Click Finish to exit the Outbound trading partner records dialog box and return to the SAP Configuration menu. Trading Partner Cross Reference setup for an outbound route is now complete.

Configuring Inbound and Outbound Extension Processing

Contents

- ▶ Overview 2
 - ▶ The Flow of Work 3
 - ▶ How to Create an Inbound and Outbound Route 5
 - ▶ Creating a Trading Partner Cross Reference 7
 - ▶ How to Create a Trading Partner Cross Reference 10
-

Overview

Introduction

In the SAP extension, you can create a Both Inbound and Outbound route. This allows you to use the same route for both inbound and outbound data instead of having separate routes for each path.

The procedure in this chapter relies on information in the previous two chapters about configuring an inbound or outbound route.

The Flow of Work

Task summary

This table summarizes the tasks you must complete to create Both an Inbound and Outbound process flow.

Task	Description
1	<p>Configure SAP to accept inbound IDocs.</p> <ul style="list-style-type: none"> ▶ Set up RFC Destination <p>Reference See RFC Destination setup in Chapter 1 of this manual for more information.</p> <ul style="list-style-type: none"> ▶ Set up SAP Port Definitions ▶ Set up Partner Profile Definition <p>Reference See Chapter 1 of the SAP System R/3 Release 3.0 EDI Interface Configuration Manual for more information.</p>
2	<p>Set up the GENTRAN:Server inbound and outbound Trading Partnership codes.</p> <p>Reference See the Trading Partnership Code Administration chapter in the <i>GENTRAN:Server Application Integration User's Guide</i>.</p>
3	<p>Set up the GENTRAN:Server inbound and outbound Maps.</p> <p>Reference See the Designing Your Map chapter in the <i>GENTRAN:Server Application Integration User's Guide</i>.</p>
4	<p>Create the supporting files.</p> <ul style="list-style-type: none"> ▶ For the inbound route portion: See Naming the Process Flow in Chapter 3. ▶ For the outbound route portion: See How to Create the Supporting Files in Chapter 4.
5	<p>Name the new process flow.</p> <ul style="list-style-type: none"> ▶ For the inbound route portion: See Naming the Process Flow in Chapter 3. ▶ For the outbound route portion: See Naming the Process Flow of Chapter 4. <p style="text-align: right;">(Continued on next page)</p>

(Contd) Task	Description
6	Create the data managers (agents) for the inbound and outbound process flow. <ul style="list-style-type: none"> ▶ For the inbound route portion: See Creating an Inbound SAP Flow in Chapter 3. ▶ For the outbound route portion: See Creating an Outbound SAP Flow in Chapter 4.
7	Complete the process flow. <ul style="list-style-type: none"> ▶ For the inbound route portion: See Completing a Flow in Chapter 3. ▶ For the outbound route portion: See Completing a Flow in Chapter 4.
8	Set up the Both Inbound and Outbound extension route to SAP. Reference See How to Create an Inbound and Outbound Route of this chapter.
9	Set up the Trading Partner Cross Reference Records. Reference See Creating a Trading Partner Cross Reference in this chapter.

Flow guidelines

Follow these guidelines when creating a new process flow:

- ▶ Give each flow in your system a unique name.
 - ▶ Use a unique name for each data manager in your system.
 - ▶ Use the flow description to help identify the flow.
-

How to Create an Inbound and Outbound Route

Introduction Both an Inbound and Outbound route defines specific flows that sends information between a trading partner and an SAP host.

Procedure Use this procedure to create a new Both Inbound and Outbound route.

Step	Action
1	Select SAP Configuration from the GENTRAN:Server Tools menu to start the extension for SAP.
2	On the File menu, select New Routing Configuration , and then click Both Inbound and Inbound .
3	Complete the Routing Configuration dialog box. Reference For more detailed information see the Routing configuration field and function table in the Configuring Inbound Extension Processing .
4	Click Next .
5	Complete the Inbound Properties dialog box. Reference For more detailed information see the Inbound Properties fields and functions table in Configuring Inbound Extension Processing .
6	Click Next .
7	Complete the Outbound Properties dialog box. Reference For more detailed information see the Outbound Properties fields and function table in Chapter 4.
8	Click Next . <p style="text-align: right;">(Continued on next page)</p>

(Contd) Step	Action
9	Select the proper EDI_DC fields and click Add to move the selected fields to the Fields in Template list to set up the Trading Partner Template. Note Use the Remove button to move fields from the Fields in Template list to the EDI_DC fields list.
10	Click Finish to exit the Trading Partner Template dialog box and return to the SAP Configuration menu. Note Your Inbound and Outbound route is now complete.

Creating a Trading Partner Cross Reference

Introduction

When a route is created, you create (or attach) trading partner cross reference records to it. A trading partner cross reference record is used for both inbound and outbound data flow.

Source dialog box

This illustration shows the Source dialog box.

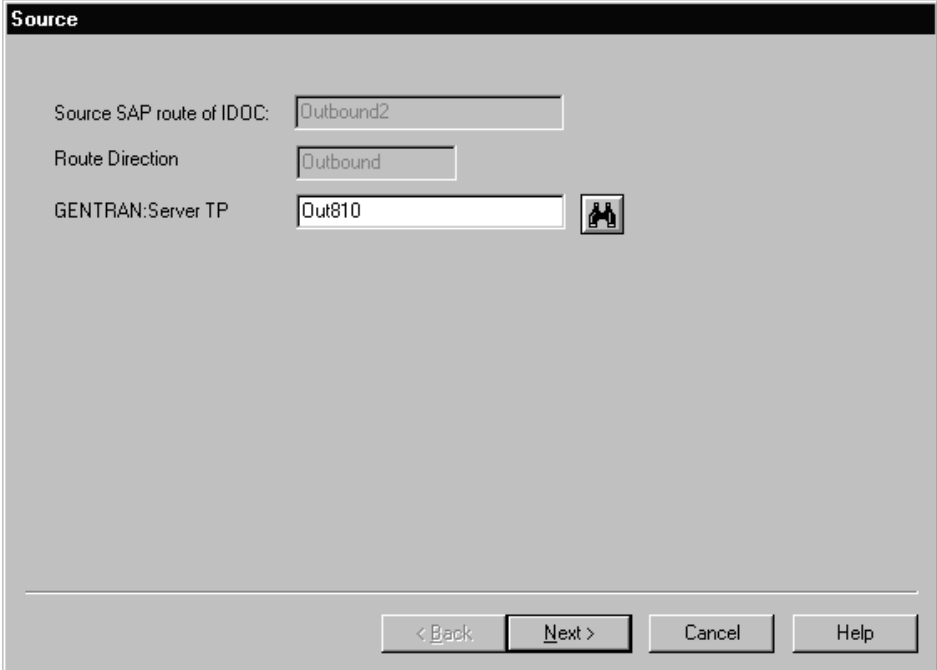

The screenshot shows a dialog box titled "Source". It contains three input fields:

- Source SAP route of IDOC: Outbound2
- Route Direction: Outbound
- GENTRAN:Server TP: Out810

At the bottom of the dialog box, there are four buttons: "< Back", "Next >", "Cancel", and "Help".

Note

This is the main dialog box for entering trading partner cross reference information. It is used for both inbound and outbound trading partner records. If this is for an inbound trading partner, then only this dialog box is available.

(Continued on next page)

Source field and function

This table describes the fields of the **Source** dialog box and their function.

Field	Function
Source SAP route of IDOC	Identifies the route where an IDoc was originated.
Route Direction	Identifies the direction of the route.
GENTRAN:Server TP Code	Identifies the GENTRAN:Server Trading Partnership code.
	Enables you to search for the correct GENTRAN:Server Trading Partnership code.

Outbound trading partner records dialog box

This illustration shows the Outbound trading partner records dialog box.

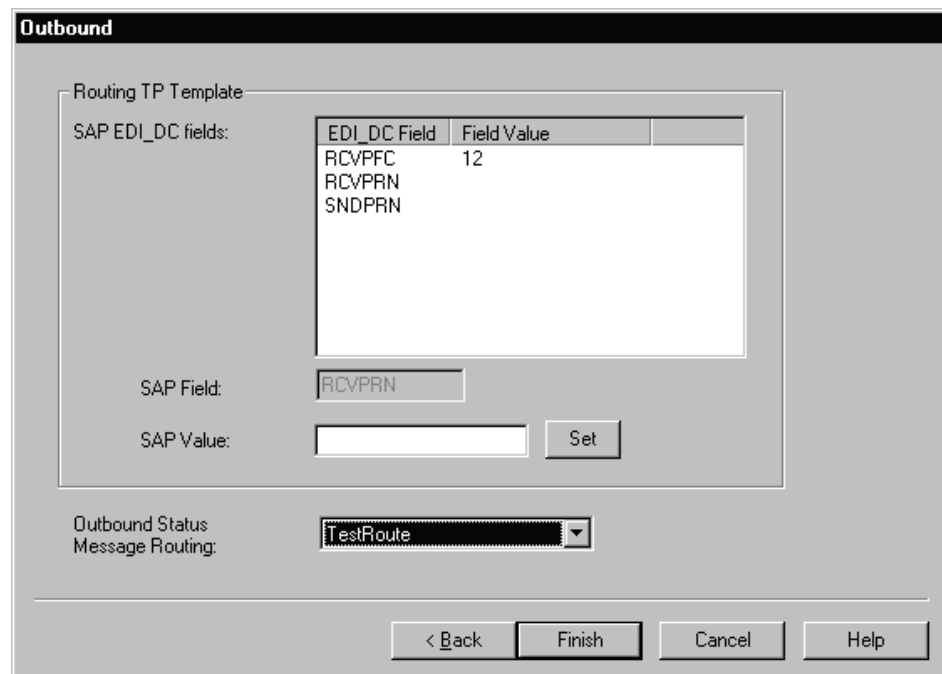

Outbound

Routing TP Template

SAP EDI_DC fields:

EDI_DC Field	Field Value
RCVFPC	12
RCVPRN	
SNDPRN	

SAP Field:

SAP Value:

Outbound Status Message Routing:

< Back Finish Cancel Help

Note

The fields that are available in this list come from the route to which this Trading Partnership record is attached.

(Continued on next page)

**Outbound
trading partner
records field and
function**

This table describes the fields of the Outbound trading partner records dialog box and their function.

Field	Function
SAP EDI_DC Fields	Identifies the fields that make up a trading partner template.
SAP Field	Identifies the EDI_DC field selected in the routing TP Template.
SAP Value	Assigns the value of the SAP field.
Set	Inserts or associates the SAP Value.
Outbound Status Message Routing	Identifies the route used to send status messages back to SAP.

How to Create a Trading Partner Cross Reference

Introduction Trading Partner Cross References define a specific trading partner to GENTRAN:Server.

Procedure Use this procedure to create a new trading partner cross reference.

Step	Action		
1	Select SAP Configuration from the GENTRAN:Server Tools menu to start the extension for SAP.		
2	Select New Trading Partner Cross Ref. from the File menu.		
3	Use this table to determine your next step.		
	IF you want to configure...	THEN Select...	AND complete...
	An inbound route	Inbound	Step 4
	An outbound route	Outbound	Step 6
4	Complete the necessary fields in the Source dialog box.		
5	Click Finish to exit the Source dialog box and return to the SAP Configuration menu. Note Trading Partner Cross Reference setup for an inbound route is now complete.		
6	Complete the necessary fields in the Source dialog box.		
7	Click Next to continue to the Outbound trading partner records dialog box. (Continued on next page)		

Step	Action
8	In the Outbound trading partner records dialog box complete the following: <ul style="list-style-type: none"> ▶ Select an EDI_DC field ▶ Enter a value in the SAP Value field ▶ Click Set
9	Click Finish to exit the Outbound trading partner records dialog box and return to the SAP Configuration menu. <p>Note Trading Partner Cross Reference setup for an outbound route is now complete.</p>

Configuring for Delayed Enveloping

Contents

- ▶ Delayed Enveloping 2
 - ▶ Flow of Work 3
 - ▶ How to Create Supporting Directories and Scripts 5
 - ▶ How to Create the Translation Flow 6
 - ▶ How to Create the Delayed Enveloping Flow 8
 - ▶ Outbound Delayed Enveloping with Inbound FA 11
-

Delayed Enveloping

What is delayed enveloping?

Delayed enveloping is a flow configuration method that enables you to:

- ▶ Run translation(s) throughout the day without enveloping the EDI data, and then
- ▶ Run translation with a parameter that performs only the enveloping process on all the collected data.

This feature increases performance by performing the enveloping process only once instead of with each translation. It also consolidates trading-partner specific data into a single file whenever possible.

Iftran program options

The architecture of the Iftran translation program enables you to run the translation process and the enveloping process in two separate operations. The following Iftran parameters are used in delayed enveloping:

- ▶ H0 - performs the data translation only
- ▶ H1 - performs the enveloping process only

Note

If you do not specify H0 or H1, Iftran runs both the translation and enveloping functions in a single pass.

Intermediate file produced

When you run translation with the H0 option, the system creates an intermediate file that contains the translated data and the Trading Partnership information necessary to create the envelope segments. When you run translation with the H1 option, the program uses the Trading Partnership information to envelope the translated data.

sigout error files

If the enveloping process fails because a Trading Partnership record is locked or in error, the system generates a type of error file called *sigout*. The system can create both error (*sigout.err*) and lock (*sigout.lok*) files. When you create a flow with the H1 translation option, you can configure your system to re-route *sigout.lok* files back through the flow until the Extension can envelope the data.

Flow of Work

Task summary

This table summarizes the tasks you must complete to create a process flow for delayed enveloping.

Task	Description
1	<p>Configure SAP to handle outbound IDocs.</p> <ul style="list-style-type: none"> ▶ Set up the RFC Destination <p>Reference See the chapter Extension Triggering in this manual for information.</p> <ul style="list-style-type: none"> ▶ Set up the SAP Port Definitions ▶ Set up the Partner Profile Definition <p>Reference See Chapter 1 of the <i>SAP System R/3 Release 3.0 EDI Interface Configuration Manual</i> for more information.</p>
2	<p>Set up the GENTRAN:Server outbound Trading Partnership records and codes.</p> <p>Reference See the Working with Trading Partnerships chapter in the <i>GENTRAN:Server Application Integration User's Guide</i>.</p>
3	<p>Create the GENTRAN:Server outbound Maps.</p> <p>Reference See the Designing Your Map chapter in the <i>GENTRAN:Server Application Integration User's Guide</i>.</p>
4	<p>Create any directories, post-processing scripts, or other supporting files.</p> <p>Reference See the topic How to Create Supporting Directories and Scripts in this chapter.</p>
5	<p>Create an outbound SAP-to-Standard flow to perform the translation process.</p> <p>Reference See the topic How to Create the Translation Flow in this chapter.</p> <p style="text-align: right;">(Continued on next page)</p>

(Contd) Task	Description
6	Create a flow to perform the enveloping process. Reference See the topic How to Create the Delayed Enveloping Flow in this chapter.
7	Set up an outbound extension route to SAP. Reference See the chapter Configuring Outbound Extension Processing for instructions.
8	Set up the Trading Partner Cross Reference records. Reference See the chapter Configuring Outbound Extension Processing for instructions.

How to Create Supporting Directories and Scripts

Introduction Before you create a new process flow, you should create the post-processing scripts, directories, and other supporting files that you plan to use in the process flow.

Procedure Use this procedure to create the supporting files for a new process flow.

Step	Action
1	<p>Do you want to run a GENTRAN:Server script after files are processed?</p> <ul style="list-style-type: none">▶ If YES, create the script and move it to the <i>./script</i> directory.▶ If NO, continue with Step 2. <p>References For instructions on creating scripts, see the Working With Scripts chapter in the <i>GENTRAN:Server Data Flow Administration Guide</i>.</p>
2	<p>Do you want to use <i>./error</i> as the error directory?</p> <ul style="list-style-type: none">▶ If YES, you may create your process flow.▶ If NO, create an error directory to hold error messages and erroneous data.

How to Create the Translation Flow

Introduction The SAP-to-Standard translation flow translates SAP data into an EDI standard format, but does not envelope the output.

H0 translation option To delay enveloping until a later time, you select the H0 translation option for the delivery agent in this flow. The H0 option:

- Suppresses enveloping of the segments
- Generates and adds TP signature information to the output so that enveloping can occur later.

Diagram This diagram illustrates an outbound translation flow.

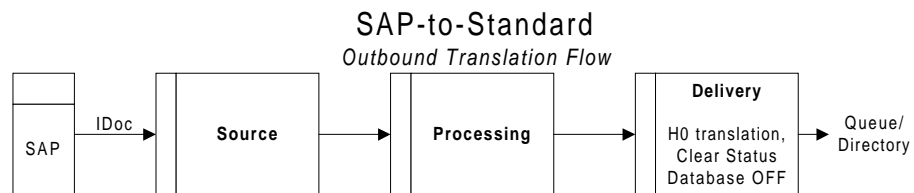

Procedure Use this procedure to create the outbound translation flow.

Step	Action
1	Click the PCM button on the GENTRAN:Server client toolbar to start the Process Control Manager.
2	Click New on the File menu to start the wizard. System Response GENTRAN:Server displays the Flow Identification dialog box.
3	Name the flow and select SAP-to-Standard as the flow type.
4	Click Next to continue to the Source agent dialog box. (Continued on next page)

(Contd) Step	Action
5	Complete the Source agent dialog box. Reference See the chapter Configuring Outbound Extension Processing for details.
6	Click Next to continue to the Processing agent dialog box.
7	Complete the Processing agent dialog box. Reference See the chapter Configuring Outbound Extension Processing for details.
8	Click Next to continue to the Delivery agent dialog box.
9	On the Delivery agent dialog box, click the Change button and select the H0 translation option from the Translation Options dialog box. Click OK to return to the Delivery agent dialog box. Note The H0 option suppresses output enveloping and generates a Trading Partnership signature file to enable delayed enveloping.
10	Clear the check box Clear Status Database on the Delivery dialog box.
11	Direct the output to a queue. Note The destination file name should be either tpsigddf or tpsignature so that the next flow can process the data. You will use this same queue as the New File Detection queue for the source agent in the enveloping flow.
12	Complete the Delivery agent dialog box and then click Next to continue to the Error Handling dialog box.
13	Complete the Error Handling dialog box and then click Next to continue to the Trading Partner Records dialog box.
14	Add Trading Partner records to the flow.
15	Click Finish to save the translation flow.
16	GO TO How to Create the Delayed Enveloping Flow in this chapter.

How to Create the Delayed Enveloping Flow

Introduction

The enveloping flow uses the TP signature in the previous (H0) translation flow's output files to envelope the segments and route the enveloped data to the appropriate trading partner. This flow also handles any sigout.lok or sigout.err errors that result from the enveloping process by writing them to the \$EDI_ROOT/sigout.lok or \$EDI_ROOT/sigout.err file.

Diagram

This diagram illustrates an enveloping and error-handling flow.

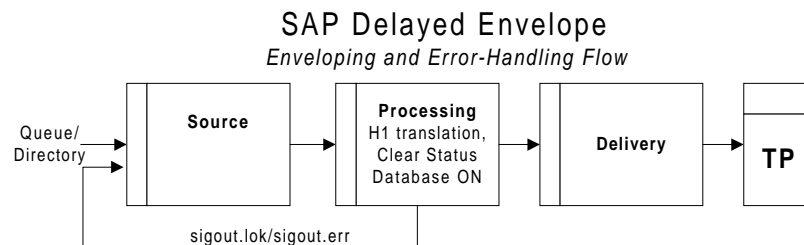

Procedure

Use this procedure to create the outbound translation flow.

Step	Action
1	Click the PCM button on the GENTRAN:Server client toolbar to start the Process Control Manager.
2	Click New on the File menu to start the wizard. System Response GENTRAN:Server displays the Flow Identification dialog box.
3	Name the flow and select SAP Delayed Envelope as the flow type.
4	Click Next to continue to the Source agent dialog box.

(Continued on next page)

(Contd) Step	Action
5	<p>On the Source agent dialog box, select Queue as the source for New File Detection. Specify the name of the queue that you used as the destination for the output of the translation flow.</p> <p>Note The input for this flow is the output of the translation flow.</p> <p>References See the topic How to Create the Translation Flow in this chapter for instructions on setting up the translation flow. See the chapter Configuring Outbound Extension Processing for detailed information about the Source agent dialog box.</p>
6	Complete the Source agent dialog box. In the Filename prefix is box, select the application file name.
7	Click Next to continue to the Processing Agent dialog box.
8	<p>On the Processing agent dialog box, click the Change button and select the H1 translation option from the Translation Options dialog box. Click OK to return to the Processing agent dialog box.</p> <p>Note The H1 option uses the Trading Partnership signatures in the input documents to envelope the data.</p> <p>Reference See the chapter Configuring Outbound Extension Processing for details.</p>
9	<p>Do you want to send status messages on Functional Acknowledgments?</p> <ul style="list-style-type: none"> ▶ If YES, make sure that the Clear Status Database check box on the Processing dialog box is checked. ▶ If NO, continue with the next step.
10	Click Next to continue to the Delivery agent dialog box.
11	Complete the Delivery agent dialog box.
12	Complete the Delivery dialog box and then click Next to continue to the Error Handling dialog box.
13	<p>Complete the Error Handling dialog box and then click Next to continue to the Trading Partner Records dialog box.</p> <p style="text-align: right;">(Continued on next page)</p>

(Contd) Step	Action
14	Add Trading Partner records to the flow.
15	Click Finish to save the translation flow.

Outbound Delayed Enveloping with Inbound FA

Diagram This diagram illustrates an outbound SAP flow with an inbound Functional Acknowledgment flow.

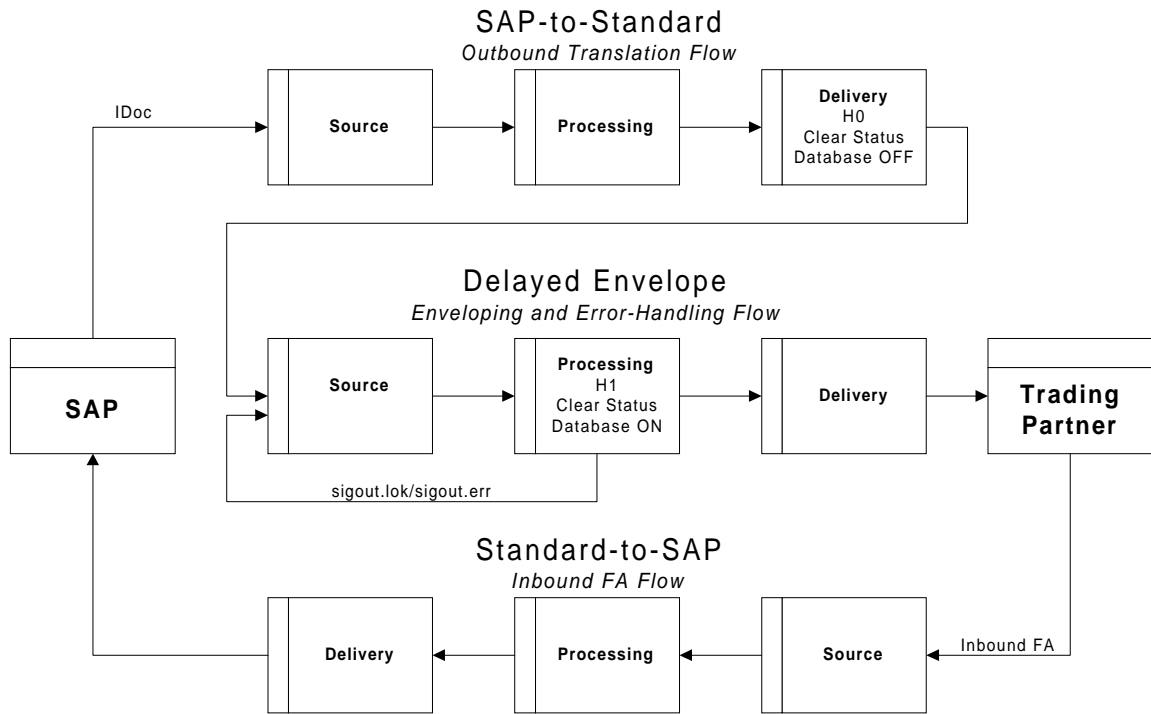

Supported SAP Status Codes

Contents	▶ SAP Status Codes	2
-----------------	--------------------------	---

SAP Status Codes

Introduction

This table lists the SAP R/3 status codes used by the extension during outbound processing of IDocs created by SAP. The extension creates one or more of the statuses listed below for each IDoc.

Sap Status/Description	Description Returned to SAP
04 No match made looking up GENTRAN Trading Partnership code in outbound trading partner cross reference.	Trading partner not found in trading partner database cross reference.
04 Multiple GENTRAN Trading Partnership codes matched in outbound trading partner cross reference.	Trading partner not found (multiple matches).
04 Match in outbound trading partner cross reference, but could not look up GENTRAN Trading Partnership code in GENTRAN Trading Partner Records.	Trading partner not found in GENTRAN Trading Partner Records.
24 Control information of EDI subsystem OK	Trading partner found and translator started
05 Error during translation	Missing or inaccessible TPCODE or map (Continued on next page)

(Contd) Sap Status/Description	Description Returned to SAP
05 Error during translation	Translation errors. No EDI data created. Compliance errors from translation. No EDI data created. Application data errors from translation. No EDI data created.
06 Translation OK	Translation OK. EDI data created.
07 Error during syntax check	Syntax error (e.g., 2 BEG 01 Mandatory element missing) Application data errors from translation Compliance errors from translation
08 Syntax check OK	Compliance check OK Compliance check during translation OK

SAP Partner Keys

Contents

- ▶ Partner Keys for SAP R/3 IDoc Version 2.x 2
 - ▶ Partner Keys for SAP R/3 IDoc Version 3.x 3
 - ▶ Partner Keys for SAP R/3 IDoc Version 4.x 4
-

Partner Keys for SAP R/3 IDoc Version 2.x

This table shows some of the fields from the EDI_DC control record in SAP R/3 version 2.x.

SAP Partner Keys				
Key Number	EDI_DC Fields	Start	Length	Example
1	RCVPRT Partner type of receiver	55	2	KU
2	RCVPRN Partner number of receiver	57	10	0000001161
3	MESCOD Logical message variant	171	3	SD1
4	MESFCT Logical message function	174	3	123
5	TEST Test option	178	1	X
6	STDMES EDI message type	165	6	ORDRSP
7	SNDPRT Partner type of the sender	189	2	LS
8	SNDPRN Partner number of the sender	191	10	0005271969

Partner Keys for SAP R/3 IDoc Version 3.x

This table shows some of the fields from the EDI_DC control record in SAP R/3 version 3.x.

SAP Partner Keys				
Key Number	EDI_DC Fields	Start	Length	Example
1	RCVPRT Partner type of receiver	55	2	KU
2	RCVPRN Partner number of receiver	57	10	0000001161
3	MESCOD Logical message variant	171	3	SD1
4	MESFCT Logical message function	174	3	123
5	TEST Test option	178	1	X
6	MESTYP Logical message type	418	6	ORDRSP
7	RCVPFC Partner function of receiver	440	2	AG
8	SNDPRT Partner type of the sender	189	2	LS
9	SNDPRN Partner number of the sender	191	10	0005271969

Partner Keys for SAP R/3 IDoc Version 4.x

This table shows some of the fields from the EDI_DC40 control record in SAP R/3 version 4.x.

SAP Partner Keys				
Key Number	EDI_DC Fields	Start	Length	Example
1	RCVPRT Partner type of receiver	274	2	KU
2	RCVPRN Partner number of receiver	278	10	0000001161
3	MESCOD Logical message variant	130	3	SD1
4	MESFCT Logical message function	133	3	123
5	TEST Test option	39	1	X
6	MESTYP Logical message type	100	30	ORDRSP
7	RCVPFC Partner function of receiver	276	2	AG
8	SNDPRT Partner type of the sender	159	2	LS
9	SNDPRN Partner number of the sender	163	10	0005271969

Status Messaging Using SYSTAT01 IDoc

Contents

- ▶ Overview 2
 - ▶ Configuring a Logical System for GENTRAN:Server 3
 - ▶ Assigning the Process Task STA1 to ALE 7
 - ▶ Configuring the GENTRAN:Server Logical System Partner Profile 12
-

Overview

Introduction

For releases 3.1G, 3.1H, and 4.x of SAP R/3 systems, it is possible to send status messages into SAP via ALE. This ability provides you with a more reliable and efficient method to transport status messages into SAP.

This appendix contains the procedures required to implement ALE status messaging. Because ALE status messaging uses an IDoc interface (SYSTAT01), it is similar to setting up the IDoc interface for EDI documents. Creating a separate partner profile for status messaging that mimics each of your partner profiles for normal IDoc transport can be laborious; therefore, SAP has created a logical partner profile to replace all the individual partner profiles that otherwise would have to be created. This appendix explains how to connect the logical system to ALE distribution, and how to set up the logical system partner profile and associated configuration.

Note

If you choose to use ALE for IDoc transport, you must also use ALE status messaging.

Configuring a Logical System for GENTRAN:Server

Introduction SAP enables you to configure a logical system process for many business relationship documents in a single definition. This section will show you how to configure a logical system for GENTRAN:Server.

Before you begin You may need a Change Request Number in order to complete this process. You may need it to change client information. Check with your SAP system administrator to determine if you need a Change Request Number.

Procedure Use this procedure to configure a logical system for GENTRAN:Server.

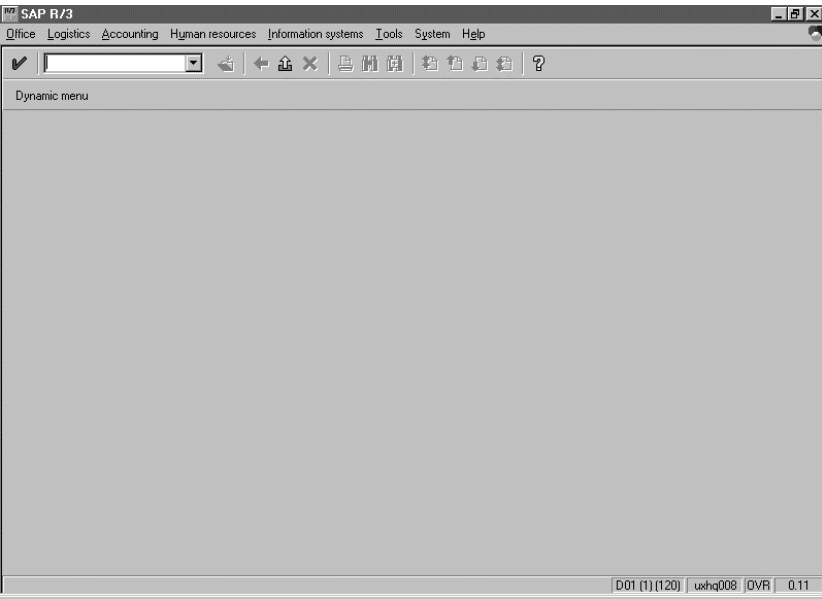
Step	Action
1	<p>Log on to your SAP system.</p> <p>System Response The system displays the SAP Start Up dialog box (or the SAP R/3 System dialog box if you are using a more current version of SAP R/3).</p>  <p style="text-align: right; color: red;">(Continued on next page)</p>

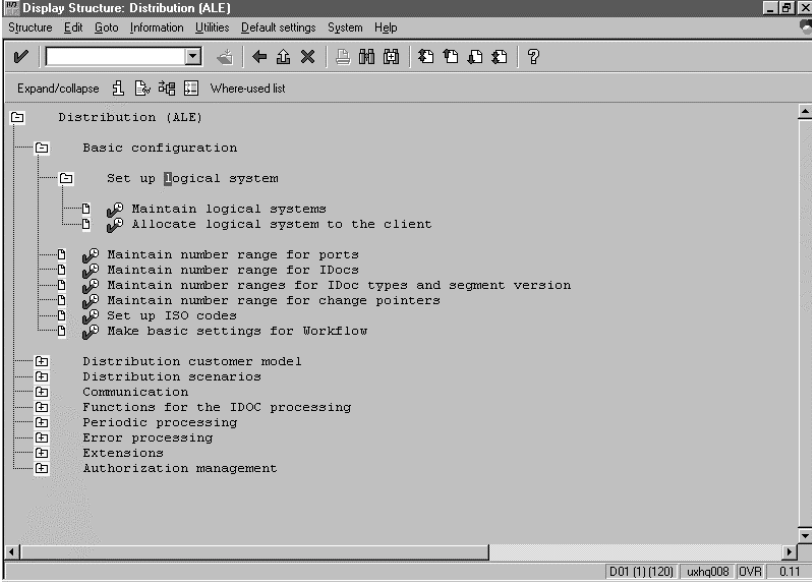
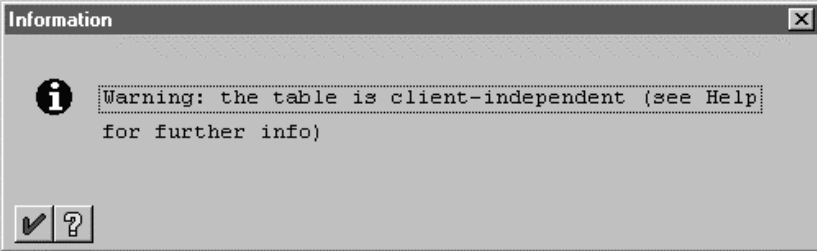

(Contd) Step	Action
2	<p>Enter Sale in the SAP main menu and click the check bar (✓).</p> <p>System Response The system displays the Display Structure: Distribution (ALE) dialog box.</p> 
3	<p>In the Display Structure: Distribution (ALE) dialog box, double-click on and expand the following trees:</p> <ul style="list-style-type: none"> ▶ Distribution (ALE) ▶ Basic configuration ▶ Set up logical systems
4	<p>Double-click Maintain logical systems under the Set up logical systems file.</p> <p>System Response The system may display a pop-up window to alert you that this area is client-independent and will affect all clients on this SAP system.</p>  <p style="text-align: right; color: red;">(Continued on next page)</p>

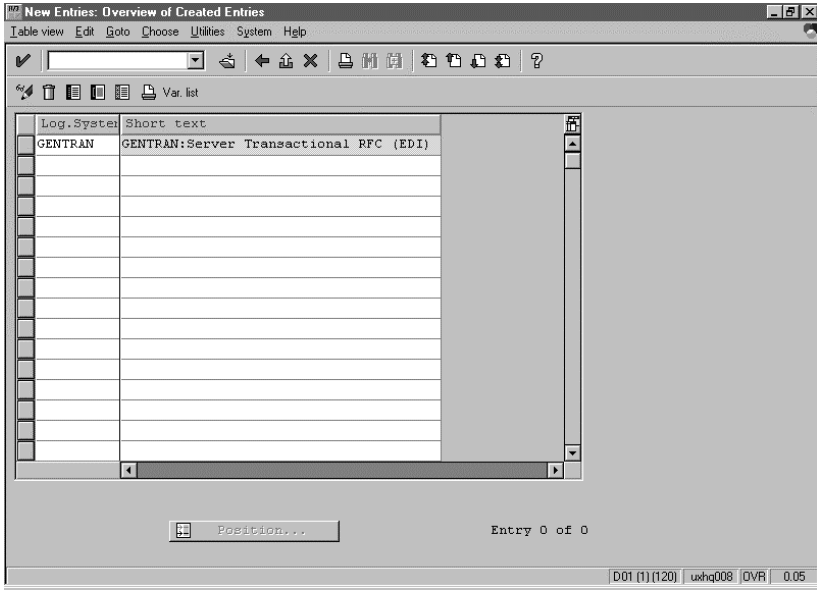
(Contd) Step	Action
5	<p>Is the warning dialog box in the previous step displayed?</p> <ul style="list-style-type: none"> ▶ If YES, click the check (✓) box to confirm your understanding. ▶ If NO, continue with the next step. <p>System Response The system displays the Change View “Logical systems”: Overview dialog box.</p>
6	<p>Click the Change icon.</p> <p>System Response The system displays a New entries button.</p>
7	<p>Click New entries in the Change View “Logical systems”: Overview dialog box.</p> <p>System Response The system displays the New Entries: Overview of Created Entries dialog box.</p> 
8	<p>In the Log.System field, enter a name for the logical system.</p>
9	<p>In the Short text field, enter an appropriate description associated with this logical system name.</p> <p style="text-align: right; color: red;">(Continued on next page)</p>

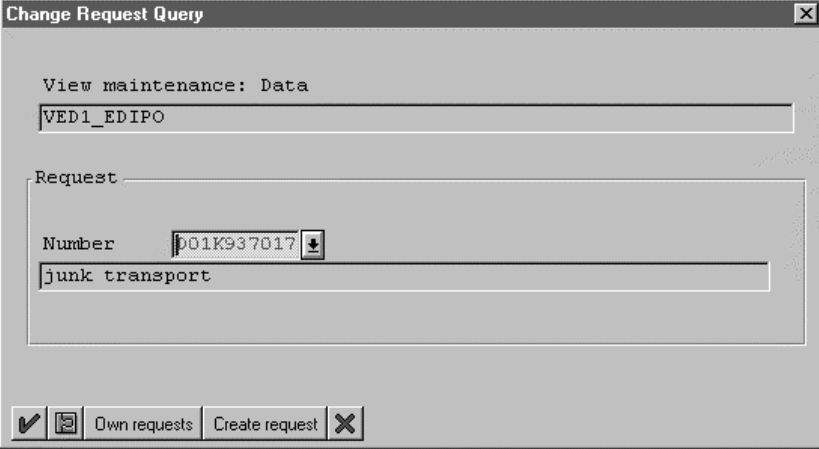
(Contd) Step	Action
10	<p>Save your new information.</p> <p>System Response The system may display the Change Request Number dialog box.</p>  <p>Note If this dialog box is displayed, you must enter an actual customizing Basis/Repair transport change request number in the Number field.</p>
11	<p>Is the Change Request Query dialog box displayed?</p> <ul style="list-style-type: none"> ▶ If YES, select your Change Request Number from the Number pull down menu and then continue with the next step. ▶ If NO, the logical system for GENTRAN:Server is complete.
12	<p>Save the Change Request Number (click the check bar (✓)).</p> <p>The logical system for GENTRAN:Server is complete.</p>

Assigning the Process Task STA1 to ALE

Introduction SAP has configured the process task STA1 to be RFC, by default. You must change this process task so that it is assigned to ALE.

Note
Process task STA1 is the SAP module for processing inbound SYSTAT01 IDocs.

Before you begin You must have a Change Request Number in order to complete this process. You will need it in order to change client information.

How to reassign the process task STA1 to ALE Use this procedure to assign the process task STA1 to ALE.

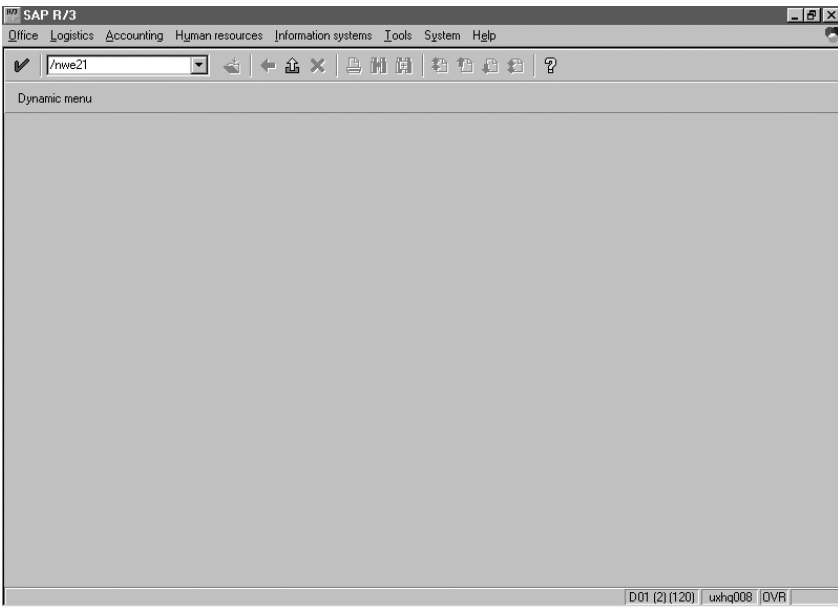
Step	Action
1	<p>Log on to your SAP system.</p> <p>System Response The system displays the SAP Start Up dialog box.</p>  <p>The screenshot shows the SAP R/3 Start Up dialog box. The title bar reads 'SAP R/3'. The menu bar includes 'Office', 'Logistics', 'Accounting', 'Human resources', 'Information systems', 'Tools', 'System', and 'Help'. The address bar shows '/nwwe21'. Below the address bar is a 'Dynamic menu' section. At the bottom right of the dialog box, the text 'D01 (2) (120) uzhq008 OVR' is visible.</p>

(Continued on next page)

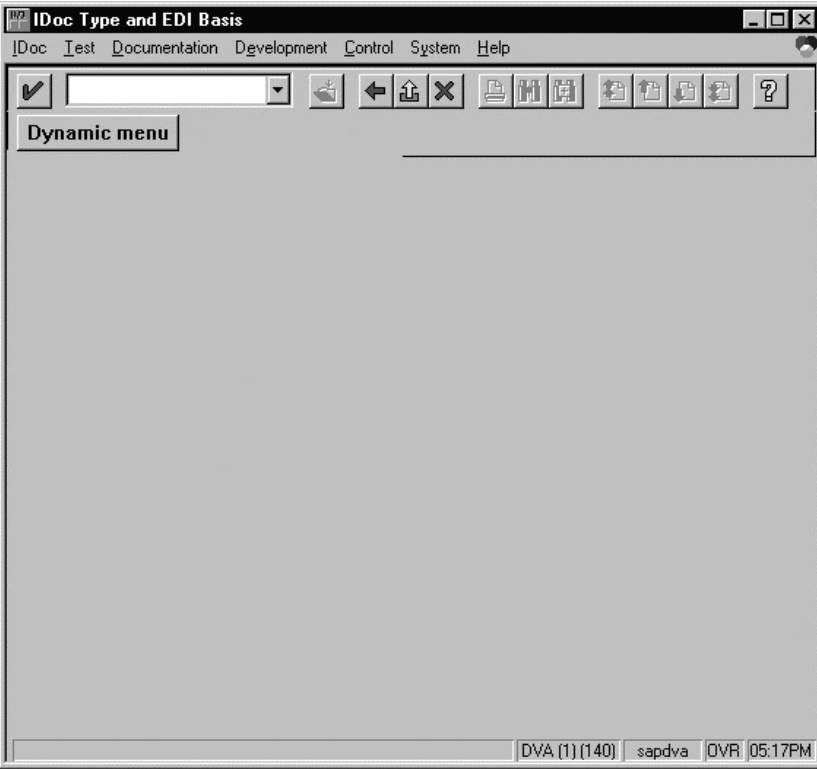
(Contd) Step	Action
2	<p>Enter wedi in the transaction field of the SAP main menu and click the check bar (✓).</p> <p>System Response The system displays the IDoc Type and EDI Basis dialog box.</p>  <p>(Continued on next page)</p>

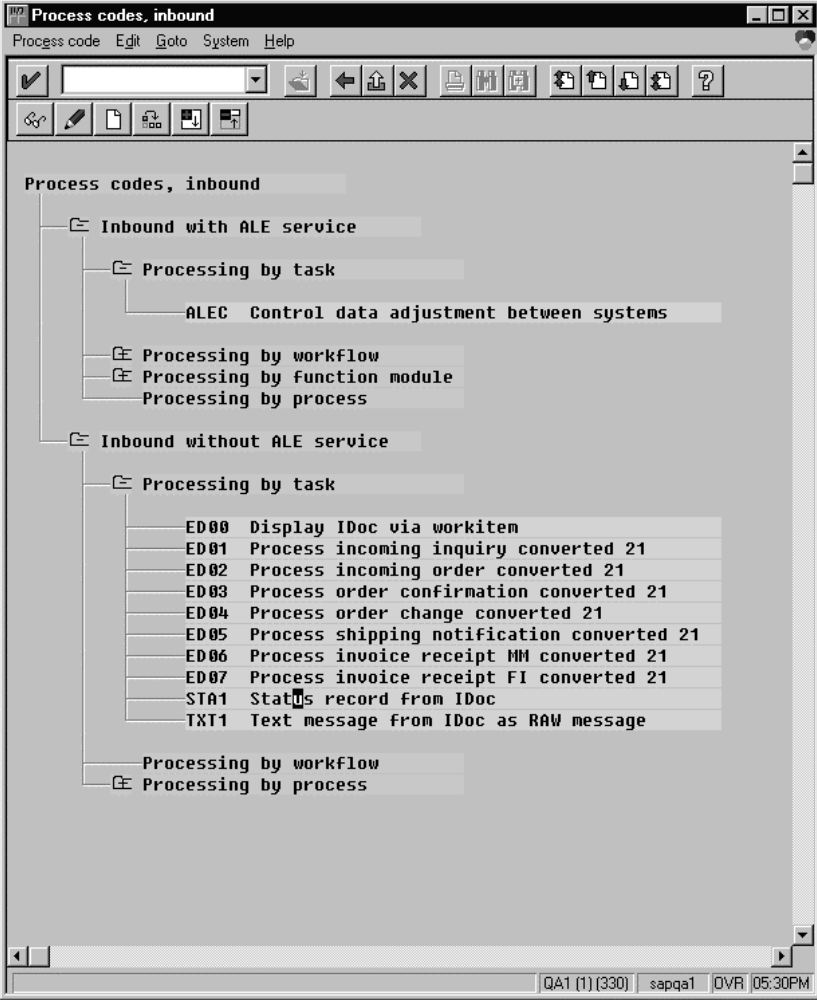
(Contd) Step	Action
3	<p>Select Inbound Process Code from the Control menu of the IDoc Type and EDI Basis dialog box.</p> <p>System Response The system displays the Process codes, inbound dialog box.</p> 
4	Highlight STA1 under the Inbound without ALE service.
5	<p>Press F6 to reassign STA1.</p> <p>System Response The system displays a dialog box informing you that STA1 will be removed from the processing by task file.</p>
6	<p>Select OK. The STA1 line disappears.</p> <p style="text-align: right;">(Continued on next page)</p>

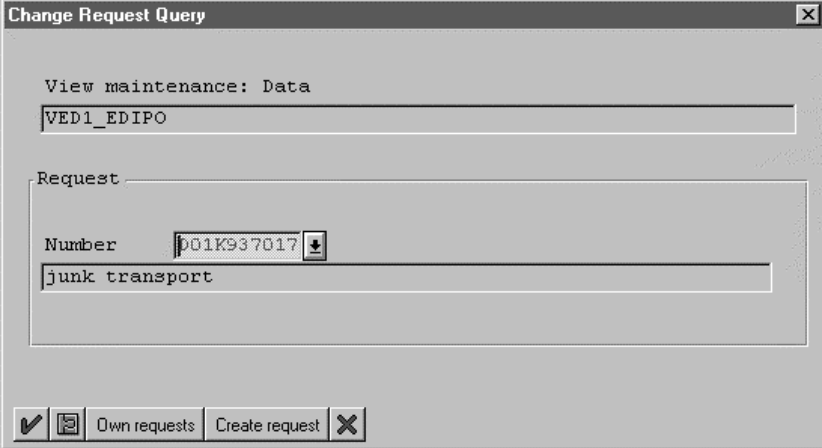
(Contd) Step	Action
7	<p>Double-click on Processing by task under Inbound with ALE service.</p> <p>System Response The system displays the Change Request Query dialog box.</p> 
8	<p>Enter the customizing Basis/Repair transport change request number in the Number menu of the Change Request Query dialog box.</p> <p style="text-align: right; color: red;">(Continued on next page)</p>

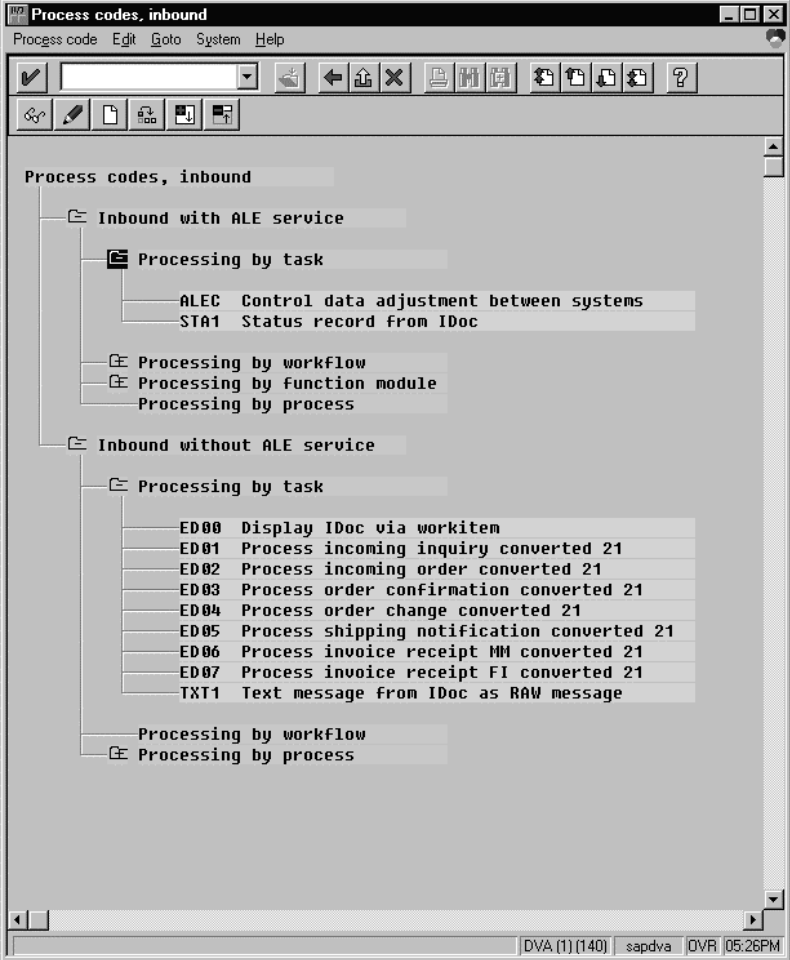
(Contd) Step	Action
9	<p>Click the check bar (✓).</p> <p>System Response The system displays the Process codes, inbound dialog box.</p>  <p>STA1 is displayed under Processing by task. Assigning process task STA1 to ALE is now complete.</p> <p>Note If you use SYSTAT01 for RFC and ALE you can add STA1 instead of reassigning it. Consult the standard SAP procedures for instructions.</p>

Configuring the GENTRAN:Server Logical System Partner Profile

Introduction

This section explains how to connect the STA1 process to ALE and the logical system profile. You must set up the port and client with the same parameters that were set up for the IDoc transfer interface using SM51.

How to configure the logical system partner profile

Use this procedure to define a GENTRAN:Server Logical System Partner Profile for ALE and the logical system profile.

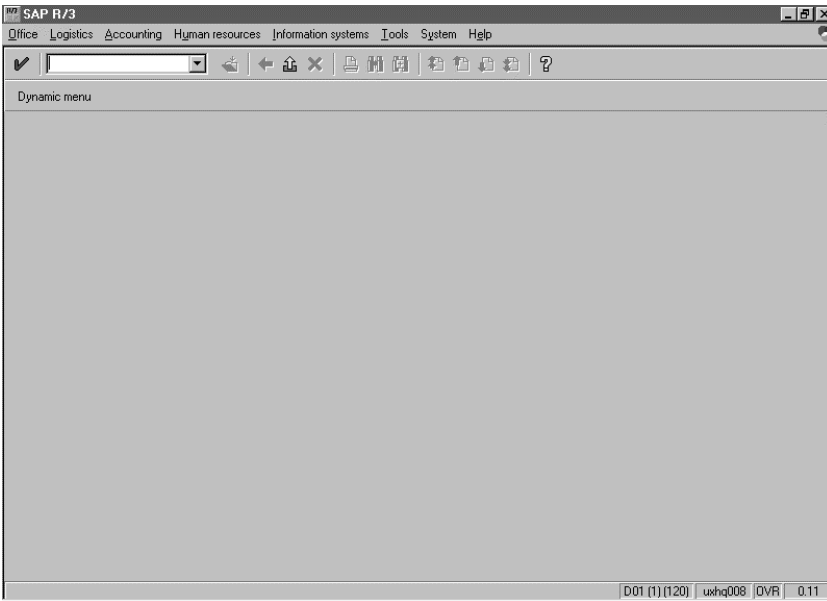
Step	Action
1	<p>Log on to your SAP system.</p> <p>System Response The system displays the SAP Start Up dialog box.</p> 
2	<p>Enter wedi in the Transaction field of the SAP main menu and click the check bar (✓).</p> <p>System Response The IDoc, partner profile dialog box is displayed.</p> <p style="text-align: right; color: red;">(Continued on next page)</p>

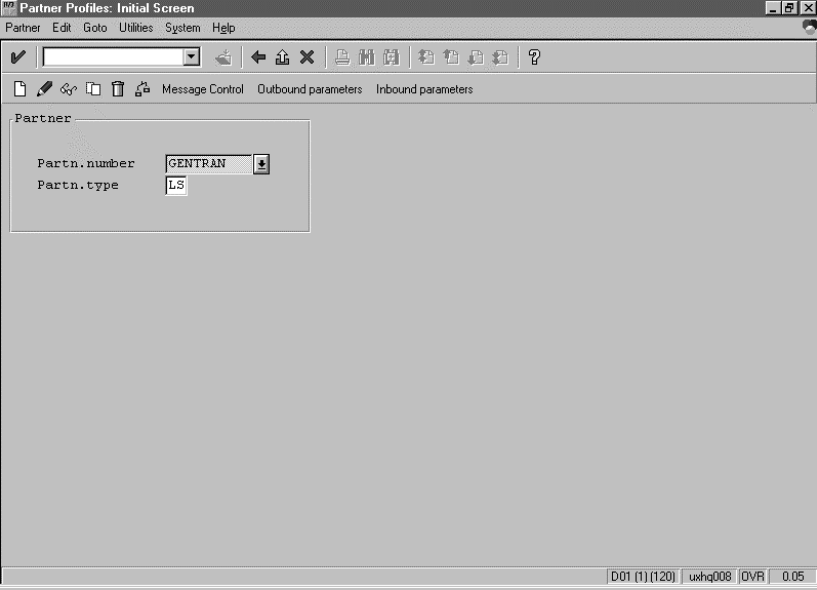
(Contd) Step	Action
3	<p>Select Partner Profile.</p> <p>System Response The system displays the Partner Profiles: Initial dialog box.</p> 
4	<p>Enter these values in the following fields:</p> <ul style="list-style-type: none"> ▶ For Partn. number enter GENTRAN ▶ For Partn. type enter LS <p style="text-align: right; color: red;">(Continued on next page)</p>

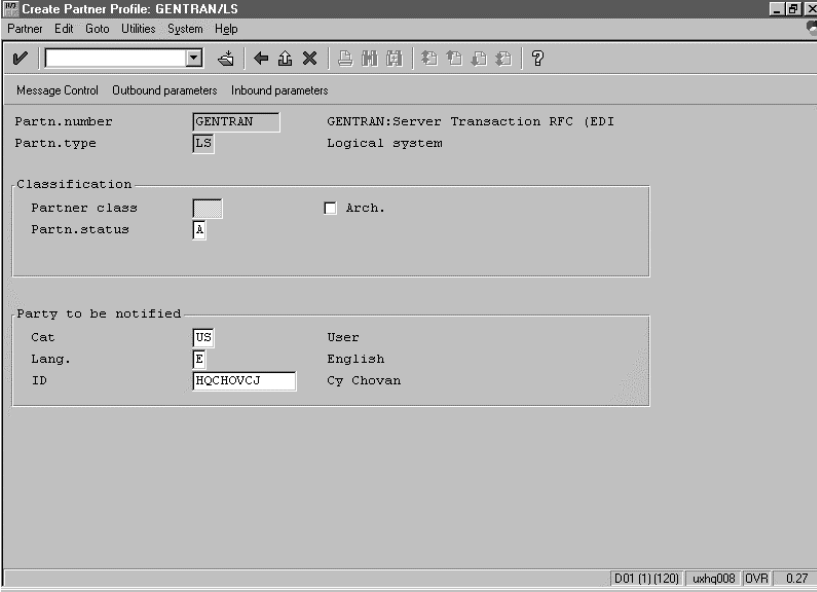
(Contd) Step	Action
5	<p>Click the pencil button.</p> <p>System Response The system displays the Create Partner Profile: GENTRAN LS dialog box.</p> 
6	Enter A in the Partn. status field.
7	Enter the appropriate values for Partner class and Archive according to your internal workflow.
8	<p>Click Inbound parameters.</p> <p>System Response The system displays the Change View “EDI Partner Profiles: Inbound Parameters”: Overview dialog box.</p> <p style="text-align: right; color: red;">(Continued on next page)</p>

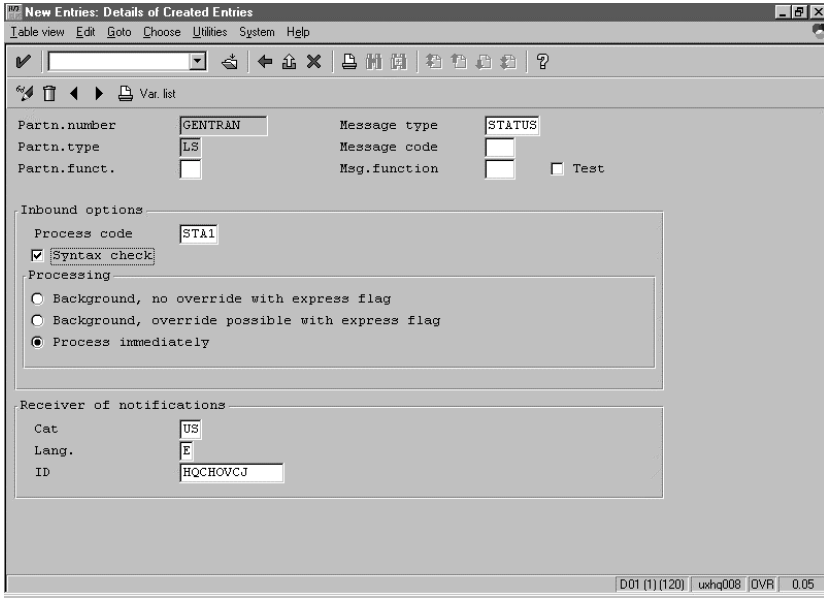
(Contd) Step	Action
9	<p>Click New entries on the Change View “EDI Partner Profiles: Inbound Parameters”: Overview dialog box.</p> <p>System Response The system displays the New Entries: Details of Created Entries dialog box.</p> 
10	Enter STATUS in the message type field.
11	Enter STA1 in the Process code field.
12	<p>Select a processing type under Processing.</p> <p>Note We recommend that the Process Immediately option be selected.</p>
13	<p>Save your new information.</p> <p>The logical partner profile is now set up and is configured for inbound status messaging via ALE.</p>

SAP Database Design

Contents

- ▶ SAP Route Configuration Table (Route) 2
 - ▶ Inbound TP Cross Reference (INBNDTP) 9
 - ▶ Outbound TP Cross Reference (OutboundTP_tb) 10
 - ▶ Dynamic Tables 12
 - ▶ Loading and Unloading SAP Database Tables 14
-

SAP Route Configuration Table (Route)

Introduction A SAP Route can be classified as an INBOUND route, and OUTBOUND route, or BOTH.

An inbound route names a method to deliver a document (either a data file or a status message file) to a specific SAP instance. The inbound route name is used in the Inbound TP Cross Reference table to determine the inbound route to SAP based on the GENTRAN:Server TPCODE.

The outbound route names a specific GENTRAN:Server flow to queue a file to, which is determined by the SAP sender's SAP port name. The outbound route determines the Trading Partner Key Fields. These are fields of the EDI_DC header which are used to look up the GENTRAN:Server TPCODE in the Outbound TP Cross Reference table.

A route that is both inbound and outbound may be specified which is a single name used for a way to route files both into and out of a SAP instance.

SAP route configuration table (ROUTE)

This table shows how the extension names a route to and from SAP R/3 version.

Field Name	Flow Direction /Used by	Key Type	Used for Trigger	Data Type	Example	Comments
Name	Both	Primary		varchar [50 bytes]	sap00	Name of this method of routing data into and out of SAP
Direction	Both			enum("INBND" "OUTBND" "BOTH")		Inbound, Outbound, or Both
TriggerType	Both [deliveridoc]			enum("ALE", "RFC", "NONE")	ALE	SAP Trigger Type. After the IDOC file has been transferred, this specifies the action used to trigger SAP. <i>(Continued on next page)</i>

Field Name	Flow Direction /Used by	Key Type	Used for Trigger	Data Type	Example	Comments
GatewayHost	Both [deliveridoc] [startRFC] [aleclient] [aleserver] [fetchidoc] [queueidoc]		Inbnd: RFC ALE Outbnd: RFC ALE FILE	varchar [50 bytes]		Name of the host running the SAP gateway process
GatewayService	Both [deliveridoc] [startRFC] [aleclient] [aleserver] [fetchidoc] [queueidoc]		Inbnd: RFC ALE Outbnd: RFC ALE FILE	varchar [50 bytes]	hw1139	Name of the port the SAP gateway process is listening to on the gateway host. Corresponds to an entry in the GENTRAN host's /etc/services file.
SAPUserID	Both [deliveridoc] [fetchidoc] [startRFC] [aleclient] [rcp] [ftp]		Inbnd: RFC ALE Outbnd: RFC (ftp& rcp)	varchar [50 bytes]	ED17	SAP Client User ID. Used for startRFC, aleclient, ftp, and rcp.
SAPPassword	Both [deliveridoc] [fetchidoc] [startRFC] [aleclient] [ftp]		Inbnd: RFC ALE Outbnd: RFC (ftp)	varchar [50 bytes]	STERLING	SAP Client Password. Used for startRFC, aleclient, and ftp. (Continued on next page)

Field Name	Flow Direction /Used by	Key Type	Used for Trigger	Data Type	Example	Comments
UNIXUserID	Inbound [deliveridoc] [startRFC]		Inbnd: RFC	varchar [50 bytes]	sapedi	UNIX account on the SAP host to RCP files to for the inbound flow.
DestFilePath	Inbound [deliveridoc] [startRFC] [fetchidoc]		RFC FILE	varchar [255 bytes]	/edi/sap/ file	Filename to pass to startRFC call, to tell SAP where to pick up the file. Also used for "FILE" file transfer type, as the directory in which to deposit IDOC files.
Trace	Inbound [deliveridoc] [startRFC] [aleclient] [aleserver]		RFC ALE	varchar [1 bytes]	Y	On the inbound flow, startRFC or aleclient is started with the -t flag. On outbound, aleserver is started with the -t flag.
AppServer	Inbound [deliveridoc] [startRFC] [aleclient]		RFC ALE	varchar [50 bytes]	hpd350	SAP Application Server
SystemIdName	Inbound [deliveridoc] [startRFC] [aleclient]		RFC ALE	varchar [50 bytes]	SSW	SAP System ID Name
SystemIDNum	Inbound [deliveridoc] [startRFC] [aleclient]		RFC ALE	varchar [50 bytes]	095	SAP System ID Number (Continued on next page)

Field Name	Flow Direction /Used by	Key Type	Used for Trigger	Data Type	Example	Comments
SystemLang	Inbound [deliveridoc] [startRFC] [aleclient]		RFC ALE	varchar [50 bytes]	E	SAP System Language (E for English)
FunctionMod	Inbound [deliveridoc] [startRFC] [aleclient]		RFC ALE	varchar [50 bytes]	EDI_DATA _INCOMIN G	SAP Function Module
EDIPortName	Inbound [finishidoc]		RFC ALE FILE	varchar [10 bytes]		Logical port name of the EDI subsystem (used in finishidoc for the SNDPOT field).
LogicalPartner	Inbound [deliveridoc] [startRFC] [aleclient]		RFC ALE	varchar [50 bytes]		ALE Logical Partner Name
Version	Outbound [GUI]		RFC ALE FILE	varchar [50 bytes]	4	SAP Version Number
PartnerKeys	PartnerKeys OutBound [sortidoc]		RFC ALE FILE	varchar [150 bytes]	SNDPRT, RCVPRT	List of IDoc field names which are used in the SAP outbound trading partner lookup.
DesType	Outbound [queueidoc]		RFC ALE FILE	enum("FLOW", "AGENT")		Type of GENTRAN:Server entity to which outbound files from SAP are routed. (Continued on next page)

Field Name	Flow Direction /Used by	Key Type	Used for Trigger	Data Type	Example	Comments
DestName	Outbound [queueidoc]		RFC ALE FILE	varchar [10 bytes]		Name of GENTRAN:Server entity to which outbound files from SAP are routed.
StatRoute	Outbound [buildstat]		RFC ALE FILE	varchar [50 bytes]		Route name to use to deliver status messages from an outbound flow to SAP.

Inbound TP Cross Reference (INBNDTP)

Inbound TP cross reference (INBNDTP) table

This table is used by the inbound postprocessing program (finishidoc) to find a SAP route name for a GENTRAN:Server Trading Partnership code.

Property	Key Type	Data Type	Example	Comments
TPCODE	Primary	varchar [40 bytes]	OUTIBM810	GENTRAN:Server TP Code for the inbound EDI standard data.
Route		varchar [50 bytes]	sap01	Name of SAP route where an inbound IDoc is delivered.

Outbound TP Cross Reference (OutboundTP_tb)

Introduction

For outbound processing, the route name is determined by examining the IDocs that are dropped off by SAP. The route name is then used to determine which SAP Partner Key template is used for the outbound TPCODE lookup (there is a one to one correspondence between the route and the Partner Key template). The SAP Partner Key template names which IDoc fields you are interested in using for the TPCODE lookup. This template is used to compose a select statement on the OutbndTP_tb table.

Note

There may be multiple records in the table with the same TPCODE, but no two records in the table should have all of the same field values.

Status messages are sent by default to the route from which the IDocs were received. The user may override this by specifying a status message route in this record.

Outbound TP cross reference (OutboundTP_tb) table

The information in this table is used by the outbound preprocessing program (sortbytp) to match an outbound SAP IDoc to a GENTRAN:Server Trading Partner.

Property	Key Type	Data Type	Example	Comments
TPCODE	Primary	varchar [40 bytes]	OUTIBM810	GENTRAN:Server TPCODE for the inbound EDI standard data.
SrcRoute	Primary	varchar [50 bytes]	sap00	Name of SAP route where the IDoc is dropped off.
StatRoute		varchar [50 bytes]	sap01	Name of SAP route to which status messages should be delivered.
MESCOD	Primary	String [3 bytes]	SD1	SAP Logical message variant.
MESFCT	Primary	String [3 bytes]	123	SAP Logical message function.
TEST	Primary	String [1 bytes]	X	SAP test IDoc - boolean value. <i>(Continued on next page)</i>

Property	Key Type	Data Type	Example	Comments
RCVPFC	Primary	String [2 bytes]	AG	SAP Partner function of the receiver.
MESTYP	Primary	String [6 bytes]	ORDRSP	SAP Logical Message Type [EDI_DC version 3 and above].
STDMES	Primary	String [6 bytes]	ORDRSP	SAP Message Type [EDI_DC version 2].
RCVPRT	Primary	String [2 bytes]	KU	SAP Partner type of the receiver.
SNDPRN	Primary	String [10 bytes]	0000001102	SAP Partner number of the sender.
SNDPRT	Primary	String [2 bytes]	KU	SAP Partner type of the sender.
RCVPRN	Primary	String [10 bytes]	0000001161	SAP Partner number of the receiver.

Dynamic Tables

Introduction The following tables are updated while documents are being processed.

Status message/ IDoc table (STATUS)

The IDoc database is created by the outbound SAPR agent. As the IDoc file is split by TPCODE, the EDI_DC record is stored here. This information will be used to generate SAP status messages for each EDI_DC as it progresses through the outbound flow.

The combination of the IDoc number and the SAP route name where the IDoc was delivered from provide a unique key for this table.

The STATROUTE field in this table is used to identify the SAP route to which the status messages should be delivered. Normally, this is the same SAP route that dropped off the IDoc for processing, but the user may provide an override for the TPCODE in the Outbound TP Cross Reference table.

This record is transient – when an EDI standard file is passed to an EDI gateway, this record is removed (MBAGID and TPCODE identify records that can be removed). Errors in the flow that cannot be recovered from leave records within this database. The CreateTime field records the time that the record was created so that garbage collection can be performed for old records.

Property	Key Type	Data Type	Example	Comments
DOCNUM	Primary	varchar [10 bytes]	0000123456	IDoc number from the EDI_DC header.
SrcRoute	Primary	varchar [50 bytes]	sap00	Name of SAP route from which the IDoc was received.
StatRoute		varchar [50 bytes]	sap01	Name of SAP route to which status messages should be delivered.
MailBagID		varchar [50 bytes]	000123456	Mailbag ID that was appended to the incoming file. <i>(Continued on next page)</i>

Property	Key Type	Data Type	Example	Comments
TPCODE		varchar [50 bytes]	IBMOUT1	GENTRAN TPCODE that was determined from the trading partner lookup on the outbound flow.
IDocVers		int [4 bytes]	3	IDoc Version Number.
CreateTime		TIME STAMP (14)	1998-09-12 12:11:33	Time this record was created.
EDI_DC		TEXT		Actual EDI_DC record pulled from the IDoc.

Loading and Unloading SAP Database Tables

Introduction You can use the **sapops** utility to load and unload database information to and from the SAP database tables:

- ▶ Route configuration table
- ▶ Inbound TP cross reference configuration table
- ▶ Outbound TP cross reference configuration table
- ▶ Status message table

Starting the program Start **sapops** from the UNIX host command line if you are running GENTRAN:Server for UNIX.

Usage `sapops -[l/n/u/p/r] -t <table> {-d x}`

Note

Do not include the slashes, braces, or brackets in the command.

These brackets [] indicate that one or more parameters are required.

These brackets { } indicate the parameters are optional.

Parameters and variables This table lists the parameters and variables defined for the **sapops** command.

Parameter	Definition
l	Loads to the database table. If you load a duplicate record, the duplicate overwrites the existing record.
n	Loads to the database table but does not rewrite duplicate records.
u	Unloads from the database.
p	Prints records in readable form.

(Continued on next page)

(Contd) Parameter	Definition
r	Selectively removes records from the database table. Note You specify the records you want to remove in a .unl file. See Example 3 for details.
d x	Delimits input or output with “x.”
t <table>	Indicates the table you want to load or unload. The table name can be: <ul style="list-style-type: none"> ▶ route (Route configuration table) ▶ intp (Inbound TP cross reference configuration table) ▶ outtp (Outbound TP cross reference configuration table) ▶ stat (Status message table)

Example 1

Load to the outbound Trading Partner cross reference configuration table.

sapops -l -t outtp

Example 2

Unload from the route configuration table. Delimit output with “x.”

sapops -u -t route -d x

Example 3

Delete records from outtp table.

Step	Action
1	Create the output file with records from the outtp table. sapops -u -t outtp > outtp.unl
2	Edit the outtp.unl file so that it contains only the records you want to delete.
3	Use sapops to delete the records contained in the outtp.unl file. sapops -r -t outtp < outtp.unl

User-Defined Status Messages

Contents

- ▶ Overview 2
 - ▶ Creating the Message File 3
 - ▶ Using the Status File in buildstat 5
-

Overview

Introduction If you have the GENTRAN:Server for UNIX ECWorkbench or Advanced Data Distribution product levels, you can generate your own status messages for IDocs.

Process This table describes the stages in the process used to generate status messages.

Stage	Description
1	Create a file to define the status messages. Reference See Creating the Status File in this appendix.
2	Use the file as an argument to the buildstat program in your translation script. Reference See Using the Status File in buildstat in this appendix.

Creating the Status File

Introduction The first step in generating your own status messages is to create an application interface that will create a status file. The buildstat program can use the status file to produce the status messages (EDI_DS or SYSTAT01 for ALE).

File contents The status file must contain these records:

- The header "User1"

The header record "User1" tells buildstat the source of the status file so it can correctly manage the data format that the file contains.
- Comma-delimited, newline-terminated records. Each record must contain the required fields described in this topic.

Note
The records in this file will closely resemble the structure of the current records that lfrtran writes into sapstat.log, that sortidoc writes into sortidoc.stat, and that ediarc writes into fa.stat.

Example file Here is an example status file. Note that each record has eight fields.

```
User1
IDOC#00000000000512014,16,"Set acknowledged and accepted",tpABC,00001234,0001,0001,001
IDOC#00000000000512015,29,"Error in ALE service",tpABC,00001234,0001,0001,001
IDOC#00000000000512014,16,"Error--no further processing",tpABC,00001234,0001,0001,001
IDOC#00000000000512014,16,"Dispatch OK",tpABC,00001234,0001,0001,001
```

Record fields These are the fields in the records.

Field	Description
1	The text "IDOC#" followed by the 16-digit IDoc number.
2	A two-character SAP status code (EDI_DS STATUS field) that you choose and define.
3	Up to 70-character text for status code, enclosed in string quotes (EDI_DS STATXT field).

(Continued on next page)



(Contd) Field	Description
4	Trading Partnership code from the source IDoc. Note Buildstat does not use the Trading Partnership code, but the clearstat program may need the value.
5	Mailbagid from the source IDoc.
6	Interchange Control Number from the source IDoc.
7	Group Control Number from the source IDoc.
8	Set Control Number from the source IDoc.

Requirements

These are the requirements for the status file:

- You must have data in all eight fields. However, the Trading Partnership code, Interchange Control Number, Group Control Number, and Set Control Number fields accept a space.
 - You define the status code and status code text.
 - You define the file name and path. The buildstat program accepts this file name and path as an argument.
-

Using the Status File in buildstat

Introduction The buildstat program accepts as an argument the name and path of a status file that you define. You can use this capability to generate status messages from the status file that you defined.

Given an intermediate status-results file as input, buildstat finds the listed IDoc numbers in the status table and creates status messages. The deliveridoc program delivers the status messages to your SAP system.

Syntax This is the syntax for buildstat:

```
buildstat [-?] [-h] [-d directory] [-a arckey] [-v lvl] statusfile mailbagid uniqueid
```

Parameters and variables

This table lists the parameters and variables defined for the **buildstat** command.

Parameter	Definition
?	Show this screen.
h	Show this screen.
v	Set verbose mode level. <ul style="list-style-type: none"> ▶ 1 = Minimal information (mainly errors only). Will sum up the number of documents processed. (1 processed 100 documents). ▶ 2 = The majority of information needed for troubleshooting. Creates a status line for each document processed. ▶ 3 = All information available. This includes the actual data itself.
a	Set arckey field in EDI_DS.
d	Directory to which the status messages are written.
statusfile	Path to the input file to be processed.

(Continued on next page)

(Contd) Parameter	Definition
mailbagid	Mailbagid to look up in the stat table. When building your own status messages, use NO_MB as the argument. This indicates that the program is to obtain the mailbagid from the source IDoc file.
uniqueid	Unique ID to use as the suffix to the output file.

Procedure Use this procedure to modify the buildstat command in a script.

Step	Action
1	Use the Script Editor or another text editor to open the script that you want to modify. Reference See the Working with Scripts chapter in the <i>GENTRAN:Server for UNIX Data Flow Administration Guide (ECWorkbench)</i> for instructions on how to open a script in the Script Editor.
2	Locate the line that contains the buildstat command.
3	For the "statusfile" argument, insert the file name and path of the status message file you created.
4	Save and test the revised script.

Utilities and Tools

Contents	▶ Introduction	2
	GENTRAN:Server Utilities	
	▶ buildstat	3
	▶ clearstat	5
	▶ deliveridoc	6
	▶ deliver_idoc_files.sh	7
	▶ dumpidoc	8
	▶ exterror	9
	▶ finishidoc	10
	▶ idoc2app.sh and idoc2ddf.sh	11
	▶ queueidoc	12
	▶ receiveidoc.sh	13
	▶ sapops	14
	▶ saproute	15
	▶ sortidoc	16
	▶ svr_enq_files.sh	17
	▶ script/sapstat.scr	18
	SAP Utilities	
	▶ aleclient	19
	▶ aleserver	20
	▶ rcprfcexec.sh	21
	▶ rfcexec	22
	▶ sc_rsh	23
	▶ startRFC	24

Introduction

In this appendix This appendix describes the main programs and scripts used to configure the processing and triggering of your SAP Extension. This appendix includes GENTRAN:Server utilities, SAP-supplied utilities, and UNIX utilities.

Verbose Mode This table describes the settings for verbose mode.

Verbose Setting	Description
1	Minimal information (mainly errors only). Will sum up the number of documents processed. (I processed 100 documents).
2	The majority of information needed for troubleshooting. Creates a status line for each document processed.
3	All information available.

GENTRAN:Server Utilities

buildstat

Description The buildstat utility builds status messages to send to SAP. The utility uses the results file from lftran, sortidoc, ediarc, or the user-supplied status results file as the input file. Given a status results file as input, buildstat looks up the listed IDocs within the status table and creates files of status messages to deliver to SAP.

Usage buildstat [-?] [-h] [-d directory] [-a arckey] [-v lvl] statusfile mailbagid uniqueid

Parameter	Description
?	Show this screen
h	Show this screen
v	Set verbose mode level
a	Set ARCKEY field in EDI_DS
d	Directory to write status files into
statusfile	Input file to process
mailbagid	Mailbag ID to lookup in stat table
uniqueid	Uniq ID to use as output file suffix

Output files are named <statroute>.<mbagid>.<uniqueid>.

(Continued on next page)

Example

```
buildstat -v 1 -d ./temp ./sapstat.log 28745 0000BK 1>> buildstat.l  
2>> buildstat.l
```

Where:

- ▶ Verbosity level = 1
- ▶ Statusfile = ./sapstat.log
- ▶ Mailbagid = 28745
- ▶ Uniqueid = 0000BK

In this example, the system redirects both the standard output(1>>) and error information (2>>) to buildstat.l (the buildstat log), which is in the temp subdirectory of the data manager's run directory (/dm_run_directory/temp).

clearstat

Description The clearstat utility removes EDI_DC entries from the status database (Status Message Table).

Usage clearstat <-h> <-v lvl> [<-t tpcode> <-m mbagid> | <-a age>]

Parameter	Description
h	Show the usage statement
v	Set verbosity level
t	Delivered documents to a TPCODE
m	Delivered documents from a MailBagID
a	Aged documents - age is specified in minutes

You can select the records you want to delete by specifying both the Trading Partnership code and the mailbag ID or by specifying the age of the record.

Example clearstat -v 1 -a 2880 1>> ../clearstat.l 2>> ../clearstat.l

Where:

- Verbosity level = 1
 - Maximum age of a record = 2880 minutes (48 hours)
 - Both the standard output (1>>) and error information (2>>) is redirected to the clearstat log (clearstat.l) found in the temp subdirectory of the data manager's run directory (dm_run_directory/temp).
-

deliveridoc

Description The deliveridoc utility sends any completed IDocs to SAP. This utility uses the named route to deliver a file to SAP and then triggers SAP.

Usage deliveridoc [-h] [-v level] [-s] [-P size] route filename

Parameter	Description
h	Show this screen
v	Set verbosity level
s	File contains status messages, always call status message processing function module (don't use function module from route table)
P	Pack size documents in a RFC call for ALE
route	Name of the inbound route to use
filename	Name of the file to deliver
b	Balanced option (workload balancing must be active). Pass to startRFC.

Example

```
deliveridoc -v 1 `saproute app2sap`
app2sap.000079.000000361.000000363 >> ../deliveridoc.l 2>> ../
deliveridoc.l
```

Where:

- Verbosity level = 1
- Uses the executable saproute to find route information (tcode is app2sap)
- Filename is app2sap.000079.000000361.000000363

In this example, the command redirects the standard output and error information to the deliveridoc log (deliveridoc.l), which is in the temp subdirectory of the data manager's run directory (dm_run_directory/temp).

deliver_idoc_files.sh

Description When invoked by sapstat.scr, deliver_idoc_files.sh creates a list of ready-to-send IDoc files and invokes deliveridoc to send them to SAP.

Usage deliver_idoc_files.sh filelist [deliveridoc_args]

Parameter	Description
filelist	A file containing the names of the file to deliver. One filename per line.
deliveridoc_args	Arguments to be passed through to deliveridoc

Example deliveridoc_files.sh .filelist -s -v 1 1>> deliveridoc.l 2>>
deliveridoc.l

Where:

- Filelist name = .filelist
- Other arguments are meant for the deliveridoc executable
- The system redirects the standard output (1>>) and error information (2>>) to the deliveridoc log (deliveridoc.l), which is in the temp subdirectory of the data manager's run directory (dm_run_directory/temp).

dumpidoc

Description The dumpidoc utility identifies a version of an IDoc and then displays field names and their values. You can use it to show the control headers in an IDoc file in a readable form.

Usage dumpidoc [-h] IDOCFile

Parameter	Description
h	Show this screen
IDOCFile	File of IDoc records to read in

Example dumpidoc idocfilename

exterror

Description The exterror program enables the SAP extension to call utilities to log their invocation and execution status in a manner consistent with that of GENTRAN:Server.

Usage exterror rc=<return code> pid=<process id> [logdir=<dir>] prog=<program>

Parameter	Description
rc	Identifies the return code
pid	Identifies the process ID
logdir	Identifies the logging directory
prog	Identifies the program name

finishidoc

Description The finishidoc utility updates route-specific fields in the EDI_DC record. The utility finishes an incomplete inbound IDoc file so that it is ready for delivery to SAP.

Usage finishidoc [-h] [-v lvl] [-a arckey] Route SourceFile DestFile

Parameter	Description
h	Show this screen
v	Set verbose mode level
a	Specify an archive key to use in the DC
Route	Inbound route to use to complete DC
SourceFile	Incomplete IDoc file to read in
DestFile	File to write finished IDoc data to

Example

```
finishidoc -v 1 `saproute app2sap`
.app2sap.000079.000000361.000000363
app2sap.000079.000000361.000000363 >> ../finishidoc.l 2>> ../
finishidoc.l
```

Where:

- Verbosity level = 1
- Uses the executable saproute to find route information (tcode is app2sap)
- SourceFile is .app2sap.000079.000000361.000000363 (note leading dot)
- DestFile is app2sap.000079.000000361.000000363

The utility redirects the standard output and error information to the finishidoc log (finishidoc.l), which is in the temp subdirectory of the data manager's run directory (dm_run_directory/temp).

idoc2app.sh and idoc2ddf.sh

Description The idoc2app utility reformats IDoc layouts extracted from a SAP system into a format that you can use to create the application description in GENTRAN:Server.

The idoc2ddf utility reformats IDoc layouts into a file definition (ddf) format.

Usage idoc2app.sh <idocfile>

idoc2ddf.sh <idocfile>

Suggestion

Idoc2ddf.sh <idocfile> > <logfile>

queueidoc

Description The queueidoc utility is used to determine an outbound route for an IDoc file.

This program:

- Examines the first IDoc
- Uses the sender's port name (SNDPOR) and the receiver's port name (RCVPOR) in the EDI_DC header to determine the outbound flow
- Copies the file to the input directory or queue of the first agent in the flow.

Usage queueidoc [-h] [-v level] [-r route] file mailbagid

Parameter	Description
h	Show this screen
v	Set verbosity level
r	Override route lookup with named route
file	Name of the input IDoc file
mailbagid	Mailbag ID to append to the file name

Example `queueidoc -v 1 `saproute app2sap` app2sap`

Where:

- Verbosity level = 1
- Uses executable saproute to find route information (tcode is app2sap)
- File to be queued = app2sap

The utility redirects the standard output and error information to the queueidoc log (queueidoc.l), which is in \$EDI_ROOT/saplogs directory.

receiveidoc.sh

Description The receiveidoc.sh script, which is rcp specific, is called to queue an IDoc file to an outbound flow. It is usually called from the rfcexec outbound trigger program supplied by SAP or from aleserver.

Usage receiveidoc.sh [-r route] file

Parameter	Description
r	Override the route lookup done by queueidoc with the named route
file	File of IDocs to process

Notes The receiveidoc.sh script is called to queue an IDoc to a flow. The normal progression of steps is:

1. Determine if the receiveidoc.sh script needs to copy the file via rcp. If the SAP port triggers GENTRAN:Server by calling the rcprfcexec.sh script, GENTRAN:Server knows to use rcp. The RCP_HOST environment variable is set to the remote host name. The rcp is used to copy the file to the local spool directory.
2. The IDoc file is copied to the SPOOL directory. If the file exists on local disk (or is nfs mounted), it is directly copied. If the file is not on local disk and the RCP_HOST environment variable is set, an rcp retrieves the file from the remote host.
3. The queueidoc program queues the IDoc file to the appropriate flow. This program examines the first IDoc, uses the sender's and receiver's port name in the EDI_DC header (SNDPOR and RCVPOR) to determine the outbound flow, and then copies the file to the input directory or queue of the first agent in the flow.

sapops

Description The sapops program is used to load, unload, and view information within particular SAP extension database tables. It is specific to the SAP extension, but is similar in structure to the GENTRAN:Server isops program.

Usage sapops { -l | -n | -u | -p | -r } -t table [-d x]

Parameter	Description
l	Load to the database
n	Load to the database, no rewrite duplicates
u	Unload from the database
p	Print records in readable form
r	Selectively remove records from the database
d x	Delimit input/output with 'x'
t table	Table name Where table name can be: <ul style="list-style-type: none"> ▶ route = route configuration table ▶ intp = inbound TP cross reference configuration table ▶ outtp = outbound TP cross reference configuration table ▶ stat = Status Message table

Example `sapops -u -t route >> route.unl`

In this example, sapops is used to create an unload (.unl) file of the route configuration table.

`vi route.unl`

```
TestRoute|BOTH|RFC|FILE|229|SAPI40|||||./
saptest|||||||3|SNDPRT,SNDPRN,RCVPRT,RCVPRN,MESCOD|FLOW|SAPOut|
```

saproute

Description The saproute program is used to gain route information as a variable for other shell scripts. It accesses the route table and retains the route name.

Usage saproute <-h> <-v level> tpcode

Parameter	Description
h	Show this screen
v	Set verbosity level

Example saproute app2sap

Output of the above command is TestRoute, which is the route name for the tpcode app2sap.

sortidoc

Description The sortidoc program splits the inbound IDoc file by Trading Partnership code and gets it ready for translation. The name of the output file is TPCODE.MBAGID.

Usage sortidoc [-h] [-v level] [-r route] [-k keystring] [-d dir] MBagID SourceFile

Parameter	Description
h	Show this screen
v	Set verbosity level
r	Override route lookup using specified route name
k	Override list of IDoc fields to use for TP lookup
d	Destination directory for output files
MBagID	Mailbag ID used when creating output files
SourceFile	Input file to process

Example

```
sortidoc -v 1 -d ./temp 13889 .IDoc.13889.000000322 1>> ./
sortidoc.l 2>> ../sortidoc.l
```

Where:

- Verbosity = 1
- Destination directory is ./temp
- Mailbagid is 13889
- Source File is .IDoc.13889.000000322

The sortidoc program redirects the standard output (1>>) and error information (2>>) to the sortidoc log (sortidoc.l), which is in the temp subdirectory of the data manager's run directory (dm_run_directory/temp).

svr_enq_files.sh

Description The svr_enq_files script moves all files that sortidoc created to the proper queue.

Usage svr_enq_files.sh filelist queueName resourcegroup

Parameter	Description
filelist	A file containing the names of files to put on the queue, one filename per line
queueName	The queue name and directory to use
resourcegroup	The queue's resource group

Example svr_enq_files.sh ".split_files" sir1_que default

Where:

- File list = .split_files
- Queue name = sir1_que
- Resource group = default

script/sapstat.scr

Description For an outbound flow, SAP expects status messages from the lead and last data manager in a flow. The lead data manager sends a status that it was able find the Trading Partnership code. The last data manager sends a status message on the success or failure of translation of the IDoc file. This script also invokes the buildstat and deliveridoc_files.sh as part of this process.

Example

```
smgr -ssapstat -estatFile=./temp/sortidoc.stat -etempDir=./temp -  
eXL_INFNAME=.IDOC.28745.000000364 -euniqfile=000000365 -  
edmName=sir0 -eEDIROOT=/training/training/PCM_51/sir0_run_dir
```

Where:

- The executable smgr -s is used to invoke the server script sapstat.scr.
 - -e files (statFile, tempDir, XL_INFNAME, uniqfile, dmName and EDIROOT) are environment variables that are used by executables invoked within the sapstat script.
-

SAP Utilities

aleclient

Description The aleclient program is used to process inbound information.

Usage aleclient -c clnt -u user -p password -3 -h apphost -s SystemNum [-l lang] [-t] [-g gwhost] [-x gwsvc] [-a ProgID] [-h] [-v lvl] [-F Fcn] [-P size] file

Parameter	Description
v	Set verbosity level
c	SAP client number
u	SAP user ID
p	SAP password
3	SAP destination is a R/3 system
h	SAP application host name
s	SAP system number
l	SAP language
g	SAP gateway host
x	SAP gateway TCP/IP service name
t	Enable RFC tracing
a	Contact external program registered at ProgID
F	SAP Function Module to invoke
P	Number of documents to pack per call to SAP

aleserver

Description The aleserver program is an extension process that contacts an SAP gateway on a specified service port and waits for delivery of IDocs.

Note

The aleserver and aleclient programs use startRFC parameters to make the connection to the SAP system and send IDocs to SAP.

Usage aleserver [-h] [-v level] [-S SpoolDir] [-T TriggerProg] -g Gateway -x Service
-a ProgID [-t]

Parameter	Description
h	Show this screen
v	Set verbosity level
S	Override spool directory to write IDocs to
T	Override trigger program to start EDI
g	SAP gateway server host name
x	SAP gateway server TCP service name
a	SAP program ID to register service as
t	Turn on RFC tracing

rcprfcexec.sh

Description The rcprfcexec utility script is a front end to the rfcexec remote function call. It is used only when rcp is used to copy the file from the SAP host. The purpose of the rcprfcexec utility script is to determine the host from which the utility has been invoked and to store this information in the environment variable RCP_HOST. The edi trigger script will use this environment variable later in the process.

Usage rcprfcexec [<rfcexec commandline, inserted by SAP>]

rfcexec

Description The rfcexec program contacts SAP to determine the EDI trigger program defined in the logical port definition. It is used to run receiveidoc.sh.

sc_rsh

Description The sc_rsh program is a common interface to the UNIX System remote shell utilities. It is used to execute remote commands in a similar manner on all supporting systems.

Usage sc_rsh [<any valid native remote shell command line>]

startRFC

Description This SAP utility notifies SAP that an IDoc file is ready for processing. The aleserver and aleclient programs use startRFC parameters to make the connection to the SAP system and send IDocs to SAP.

Usage startRFC - [<SAP version>] -d [<SAP System ID>]

Parameter	Definition
u	[<User ID>]
p	[<User Password>]
l	[<SAP System Language>]
c	[<client>]
h	[<host>]
s	[<SAP System ID number>]
g	[<SAP Gateway>]
x	[<SAP gateway service>]
E PORT	[<port>]
F	[<function module>]
E PATHNAME	[inbound spool outbound spool status spool]

idoc2app.sh and idoc2ddf.sh Utilities

Contents

- ▶ Using the idoc2app.sh and idoc2ddf Utilities 2
 - ▶ Reading Attributes from idoc2app.sh Output Files 4
 - ▶ Identifying and Creating a Looping Structure 6
-

Using the `idoc2app.sh` and `idoc2ddf` Utilities

Introduction

The SAP Extension's `idoc2app.sh` utility converts extracted IDoc files to a user-defined (UDF) flat file format that you can read into the Visual Mapper's Application Editor. Reading the flat file into the Application Editor converts the file into an application description.

The `idoc2ddf.sh` utility converts extracted IDoc files to file definitions (.ddf format) that you can use in GENTRAN:Server's Application Integration mapper.

Note

The SAP Extension gets files from the SAP IDoc documentation tool (IDoc parser). However, these files are *not* in a format that the SAP Extension or GENTRAN:Server can use. The `idoc2app.sh` and `idoc2ddf` utilities convert the files into a format that GENTRAN:Server and the SAP Extension can use.

Uses of the utilities

Use the `idoc2app.sh` and `idoc2ddf.sh` utilities in the following situations:

- ▶ The SAP IDoc layout has changed due to site-specific modifications to your SAP configuration.
- ▶ You have installed and are using a new SAP release.
- ▶ The IDoc layout you need was not supplied with the extension software.

How the utilities work

In the directory in which `idoc2app.sh` or `idoc2ddf.sh` is executed, the utility generates a file for each IDoc layout encountered when the SAP Extension received the file from the IDoc parser tool. Each file is named for the IDoc document (for example, ORDERS02).

(Continued on next page)

Command format

The `idoc2app.sh` and `idoc2ddf.sh` commands are always run from the command line. This is the format of the commands:

```
idoc2app.sh idocfile
```

```
idoc2ddf.sh idocfile
```

Where:

<idocfile> is the output filename from the SAP IDOC parser.

Note

We recommend that you direct the output to a log file.

```
idoc2ddf.sh idocfile > logfile
```

After you run the command

After you run `idoc2ddf.sh`, you can use the resulting file definitions in an Application Integration map. No other steps are necessary.

After you run `idoc2app.sh`, you must read the resulting files into the Visual Mapper's Application Editor to convert the files into application descriptions.

Reference

See [Reading Attributes from idoc2app.sh Output Files](#) for instructions.

Requirements for IDOC parser tool

When you use the SAP IDoc parser tool with the extension, you must make certain selections for proper processing. Select the following options in SAP:

- ▶ Output IDoc records
- ▶ Output IDoc types
- ▶ Output segment fields

On the SAP Documentation: Record Types screen (Transaction WE61) you must check the control record box. Both `idoc2app` and `idoc2ddf` require the control records. If the control records are not present, the programs will not run.

Reference

See the SAP documentation, *The EDI Interface—Basis*, for more information about using the IDoc parser tool.

Reading Attributes from idoc2app.sh Output Files

Introduction After you run the **idoc2app.sh** utility, you must read the files that **idoc2app.sh** created into the GENTRAN:Server Application Editor to convert them into application descriptions.

Procedure Use this procedure to read files that **idoc2app.sh** created into the Application Editor.

Step	Action
1	On the GENTRAN:Server Open Application screen, click Create New .
2	Click Read UDF attributes from a flat file . Click OK . <div data-bbox="652 968 1395 1482" style="border: 1px solid black; padding: 10px; margin: 10px 0;"> </div>

(Continued on next page)

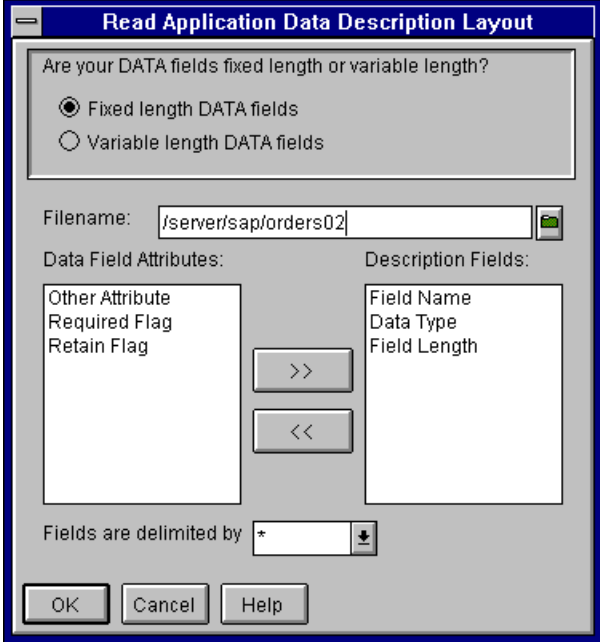
(Contd) Step	Action
<p>2 (cont'd)</p>	<p>System Response The system displays the Read Application Data Description Layout screen.</p> 
<p>3</p>	<p>Click Fixed length DATA fields.</p>
<p>4</p>	<p>In the Filename drop-down list box, select the filename that the idoc2app.sh utility created (ORDERS02 on this example screen).</p>
<p>5</p>	<p>Move the following Data Field Attributes from their list box into the Description Fields list box, selecting the attributes in the following order:</p> <ul style="list-style-type: none"> ▶ Field Name ▶ Data Type ▶ Field Length
<p>6</p>	<p>Select "*" (asterisk) as the delimiter in the Fields are delimited by drop-down list box.</p>
<p>7</p>	<p>Click OK to save your changes.</p>
<p>8</p>	<p>Continue with the next topic, Identifying and Creating a Looping Structure.</p>

Identifying and Creating a Looping Structure

Introduction After you read the IDoc layout into the Application Editor, you must identify the looping structure.

Reference

See the *GENTRAN:Server Data Flow Administration Guide* for step-by-step instructions for creating loops.

Identifying loops To help you identify the loops, the **idoc2app.sh** utility inserts BEGIN_GROUP and END_GROUP records. You can use the prefix numbers associated with the BEGIN_GROUP and END_GROUP records to identify which records are part of a loop you must create.

Dialog box The following dialog box shows the ID field for the record at the bottom of the screen.

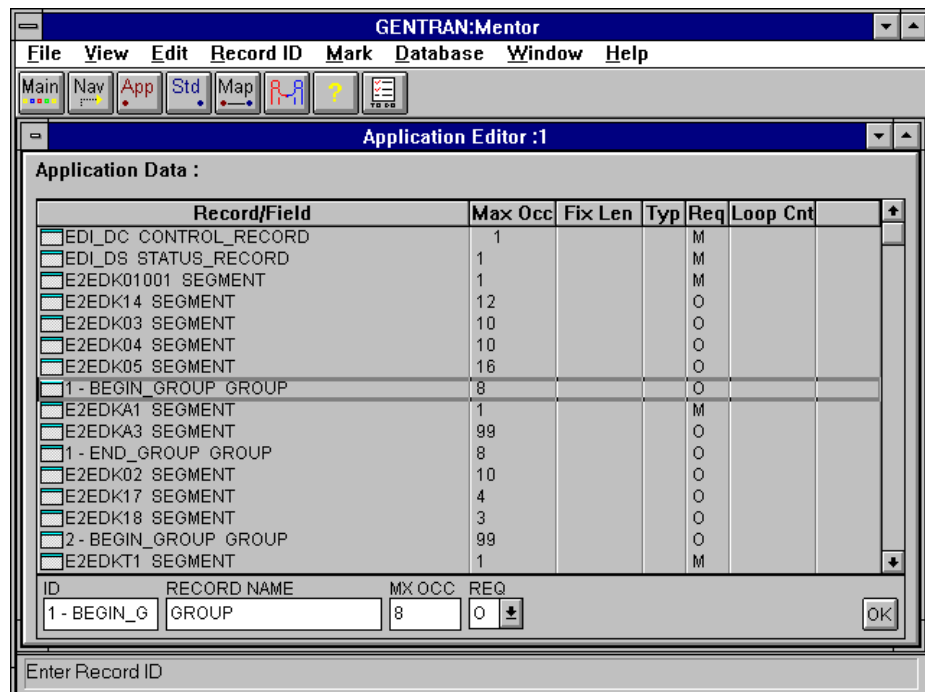

(Continued on next page)

How the looping structure works

When the `idoc2app.sh` utility runs, it reads the IDoc parser file extracted from SAP and obtains the maximum occurrence (Max Occ) value for the segments in the group.

The value in the Max Occ field for the BEGIN_GROUP record identifies the loop count for the loop you must create. In the preceding example screen, the E2EDKA1 SEGMENT has a loop count of 8.

Creating the loop

When you create the loop, you must enter the valid number for the loop count based on the number you find in the Max Occ field for the BEGIN_GROUP record.

Dialog box

The following dialog box shows the loop count number based on the Max Occ field for the BEGIN_GROUP record (shown in this example as 8).

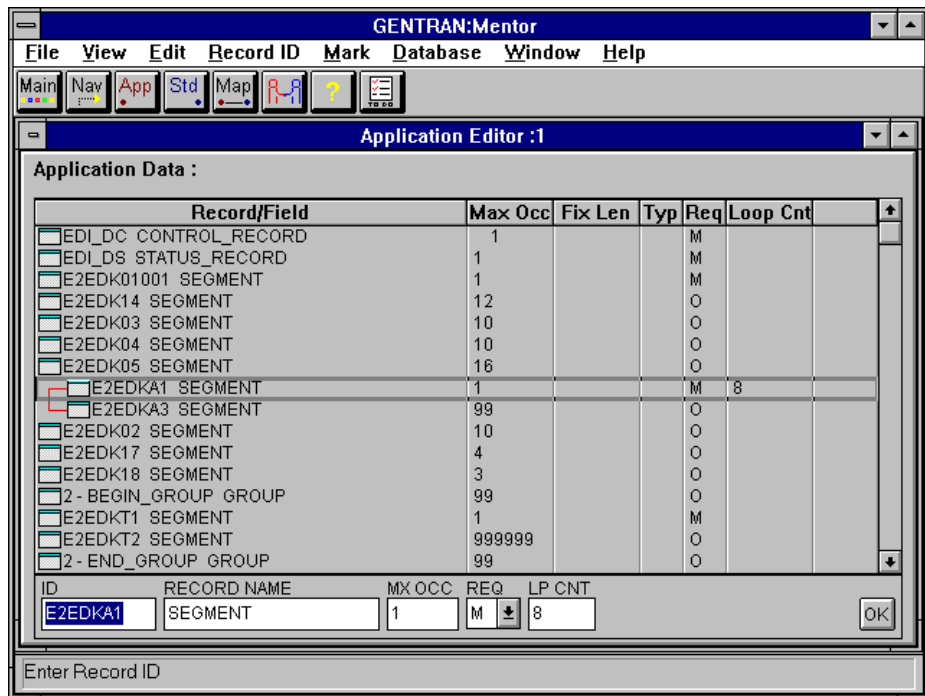

(Continued on next page)

Deleting records

After you create all the necessary loops, you must delete the BEGIN_GROUP and END_GROUP records that the **idoc2app.sh** utility inserted.

Note

You also must delete any unnecessary records (such as the EDI_DS STATUS_RECORD) that the **idoc2app.sh** utility extracted from SAP.

Index

Numbers

04 status code *A-2*
 05 status code *A-2*
 06 status code *A-3*
 07 status code *A-3*
 08 status code *A-3*
 24 status code *A-2*

A

ALE *2-33*
 status messaging via *C-2*
 ALE distribution
 configuring *C-7*
 ALE Port Definition *2-33*
 ALE server *2-21*
 ALE-based IDOC transfer, *2-7*
 aleserver program, *2-7*
 Application Linking and Enabling (ALE) *1-2*
 Application Programming Interface (API) *1-2*
 appm intelligent agents, *1-5*
 Assigning the Process Task STA1 to ALE *C-7*

B

BEGIN_GROUP and END_GROUP records, *G-6*
 Both an Inbound and Outbound *5-3, 6-3*

C

configuring
 logical system partner profile *C-12*
 logical system with ALE distribution *C-7*
 triggering, *2-37*
 Configuring a Logical System for GENTRAN
 Server *C-3*
 Configuring Inbound File-Based Triggering *2-37*
 Configuring Outbound File-Based Triggering *2-39*
 Configuring the GENTRAN
 Server Logical System Partner Profile *C-12*
 conventions
 underscore, *vi*
 used in this document, *v*
 Create a Trading Partner Cross Reference *4-51*
 Create an Outbound Route *4-47*
 Create Both an Inbound and Outbound Route *5-5*

D

database tables
 loading and unloading *D-13*
 documentation conventions, *v*

E

EDI_CALLER_ID environment variable, *2-6*
 EDI_DC control record,
 fields/SAP partner keys, *B-2, B-3, B-4*
 edirfcexec program, *2-5*
 environment variables
 EDI_CALLER_ID, *2-6*
 Error Handling dialog box *4-32*

F

File-Based Triggering *2-37*
 file-based triggering
 using NFS, *2-3, 2-26, 4-31*
 using remote copy, *2-5*
 Flow Identification dialog box *3-10, 4-7*

G

GENTRAN:Server Extension to SAP R/3
 uses, *ii*

H

How to Create an Inbound Route (To SAP) *3-51*

I

identifying looping structure, *G-6*
 IDOC
 definition of, *1-2, 2-2*
 parser tool, *G-3*
 IDOC layout
 and looping structure, *G-6*
 reformatting, *1-2*
 IDOC numbers
 status messaging using SYSTAT01 *C-1*
 IDOC version 2.x *B-2*
 IDOC version 3.x *B-3*
 IDoc version 4.x *B-4*
 IDOC2APP utility,
 reading files created by, *G-4*
 inbound processing,
 intelligent agents, *1-3*

Inbound properties 3-48
 intelligent agents,
 appm, 1-5
 intermediate documents (IDOCs), 1-2, 2-2

L

logical system
 configuring with ALE distribution C-7
 logical system partner profile C-12
 looping structure, G-6
 loops, identifying, G-6

N

Network File System (NFS) 1-2
 NFS-based triggering 2-37, 2-39
 Non-nfs-based Trigger 2-41

O

Outbound properties 4-44
 Outbound Trading Partner Cross Reference 4-48
 Outbound trading partner records 4-49

P

parser tool, SAP IDOC, G-3
 partner keys, SAP, B-1, D-1
 partner profile
 logical system partner profile C-12
 status messaging C-2
 process flows
 two-agent
 naming and describing 3-12, 4-9
 setting up error handling instructions 3-37, 4-34
 setting up source agent for 3-19, 4-16
 setting up translation agent 3-27, 3-31, 4-20, 4-27

R

RCP-based Trigger 2-38
 rcprfcexec.sh 2-19
 reading files created by IDOC2APP utility, G-4
 reassign the process task C-7
 related publications, *iv*
 Remote Copy 2-16
 Remote Copy (RCP) 1-2
 RFC Port Definition 2-26
 rfcexec 2-14, 2-40
 rfcexec program, 2-4, 2-6
 Routing configuration 3-46, 4-43

S

SAP
 multiple clients, 1-2
 multiple hosts, 1-2
 multiple ports, 1-2
 status codes, supported, A-1
 SAP ALE Server Configuration 2-21
 SAP Configuration for NFS 2-11
 SAP Configuration for Remote Copy 2-16
 SAP Connectivity Configuration 2-11
 SAP IDOC parser tool, G-3
 SAP Inbound Route Configuration 3-44
 SAP partner keys, B-1, D-1
 SAP Port Configuration 2-26
 SAP script 3-15
 SAP Status Codes A-2
 SAP status codes, supported, A-1
 sapenq program, 2-4, 2-6
 sapenq, 2-7
 sapops D-13, F-14
 sortidoc F-16
 Source 4-48
 source agent 3-19, 4-16
 Source Setup dialog box 3-16, 4-13
 STA1 process
 connecting to ALE and the logical system
 profile C-12
 STA1 to ALE C-7
 status codes
 SAP, supported, A-1
 status messaging
 using SYSTAT01 C-1
 status reporting, 1-2
 SYSTAT01 IDOC, status messaging C-1

T

Trading Partner Records dialog box 3-40, 4-37
 Trading partner template 4-45
 Translation Options dialog box 3-25, 4-25
 trigger logins, setting up, 2-39
 trigger program (sapenq), 2-6
 triggering, 1-2, 2-2
 configuring, 2-37

U

UDF flat file format,
 for files extracted from SAP, G-2
 UNIX System, *ii*
 scripting facilities, *ii*