

Sterling Integrator



Overview

Version 5.1

Sterling Integrator



Overview

Version 5.1

Note

Before using this information and the product it supports, read the information in "Notices" on page 47.

Copyright

This edition applies to Version 5 Release 1 of Sterling Integrator and to all subsequent releases and modifications until otherwise indicated in new editions.

© **Copyright IBM Corporation 2000, 2015.**

US Government Users Restricted Rights – Use, duplication or disclosure restricted by GSA ADP Schedule Contract with IBM Corp.

Contents

Chapter 1. Introduction to Sterling

Integrator 1

Introduction to Sterling Integrator	1
Evolving Business and Integration Objectives	1
Solving Business Problems Through Integration	1
Meeting Integration Challenges	3
Trading Partner Management	3
Data Transformation	4
Process Automation	4
Human Workflow Automation	5
Monitoring and Managing Processes	5
Enterprise Integration	6

Chapter 2. The Sterling Integrator

Advantage. 9

The Sterling Integrator Advantage	9
Business Process Approach	9
Modular Design	9
Building on Your Existing Assets	10
Leveraging Industry Standards	10
Robust Security Model.	11
Perimeter Services	11
Full Process Recovery	12
Connecting People to Data with Web Extensions	12
Interoperability with Gentran:Server and Connect Products	12
Additional Components	13

Chapter 3. Getting Sterling Integrator to

Work for You 15

Getting Sterling Integrator to Work for You.	15
Identifying Process Improvement Opportunities	15
Sterling Commerce Resources	16

Chapter 4. Architectural Overview . . . 17

Architectural Overview	17
Sterling Integrator Technical Framework.	18
Sterling Integrator's Functional Framework.	19
Fundamental Components of Sterling Integrator	20
Business Process Engine	20
Services and Adapters	22
Graphical Process Modeler	24
Mapping and Data Transformation Components	26

Chapter 5. Features Overview 31

Role-Based Security.	31
------------------------------	----

Perimeter Server.	31
Internationalization and Localization Support	32
Predefined Business Process Models	32
Trading Profile Management.	32
Dashboard Interface	33
Integration with Sterling Community Manager	34
Mail Box Service.	35
MESA Developer Studio	35
Web Extensions	35
AS2 Edition	36
AS3	36
Sterling File Gateway	36
EBICS Banking Server Module	37
Sterling e-Invoicing.	37
Tracking and Searching Capabilities	38
Online User Documentation	39

Chapter 6. Implementation Overview . . 41

Implementation Overview	41
Implementation Process	41
Creating Architectural Design Plan	41
Determining System and Hardware Requirements.	42
Obtaining Product Training	42
Network Deployment Planning.	43
Installing Sterling Integrator.	43
Tuning Sterling Integrator	44
Configuring Permissions and Creating User Accounts	44
Configuring Services and Adapters	44
Creating and Migrating Translation Maps	45
Checking Documents In and Out of Sterling Integrator	45
Importing Translation Maps from Gentran:Server	45
Creating Business Process Models	45
Scheduling the Business Process Models.	45
Associating Communication Adapters with Business Processes	46
Creating Trading Partner Profiles	46
Testing the Business Processes	46
Scheduling Archiving and Purging	46

Notices 47

Chapter 1. Introduction to Sterling Integrator

Introduction to Sterling Integrator

Thank you for choosing Sterling Integrator! In choosing this product, you join hundreds of companies around the world using the leading business integration platform to streamline business processes. Sterling Integrator is a transaction engine that runs the processes you define and manages them according to your business requirements. Its platform supports high-volume electronic message exchange, complex routing, translation, and flexible interaction with multiple internal systems and external business partners. Sterling Integrator:

- Ties together applications, processes, data, and people, both within and outside your organization
- Offers flexible options for deployment, configuration and customization, including the functionality to add capabilities one at a time
- Complements, rather than, disrupts your critical existing systems
- Provides a robust security infrastructure
- Includes innovative visual management tools for easy configuration of and visibility into work flows, system and trading partner activities, translation maps, and business process implementation
- Works with existing and emerging business and communication standards

Together, these features enable you to configure the components that enable you to meet your evolving application integration requirements.

Evolving Business and Integration Objectives

Application integration has been crucial since the early days of e-business, but never to the degree that it is today. Accelerated demands of the global marketplace are forcing businesses to adapt constantly to changing communication requirements, shrinking product development cycle times, and increased competitive pressures.

While past approaches to integration brought important efficiencies, they do not represent complete end-to-end integration. Like many firms, you probably have in place limited-purpose middle-ware such as file transfer, Electronic Data Interchange (EDI), message queuing, Internet B2B gateways, direct database access, Enterprise Application Integration (EAI) brokers, and custom-coded interfaces.

The resulting pockets of integrated applications across a landscape of largely unintegrated and unmanaged applications leave you ill-prepared to keep up with today's demands. You need ambitious new ways to carry out e-business in order to retain your competitive edge through increased efficiency.

Solving Business Problems Through Integration

You may be experiencing any of the following combination of business challenges related to integration:

- Backlog of E-Business Initiatives
- Growing Internal and External Interaction Demands
- Meeting Regulatory and Industry Mandates

Backlog of E-Business Initiatives

Many factors contribute to a backlog of e-business projects, including:

- Growing number of business applications needing to be integrated
- Growth in total volume of business
- Mergers and acquisitions compounding integration challenges
- Tightening IT budgets forcing increased efficiency with fewer resources

Our modular licensing and implementation model enables you to make quick progress against backlog by starting small and incrementally introducing enhanced automation to your processes. This method helps you avoid the pain of a revolutionary upheaval.

Growing Internal and External Interaction Demands

Factors that drive an organization's IT requirements include:

- New and increasing demands for real-time information interactions
- Need for real-time visibility into business activities, such as order processing, status checking, and inventory optimization
- External requirements to deploy new standards-based XML-centric B2B protocols
- Need for deeper levels of internal application integration

Sterling Integrator is designed to operate with emerging standards and protocols, enabling you to add the appropriate components to your system when the requirement arises.

The user interface includes wizard-driven configuration and deployment steps, eliminating the requirement for custom coding. This accelerates your transition times and return on investment, as a result of which your company can focus on higher-level business problems.

The product architecture lets you integrate new procedures into your processes on the fly. The tracking capabilities provide a 360-degree view of customer transactions, including a single console facilitating real-time monitoring of your processes and transactions.

When integrated with Sterling Community Manager[®], you can use Sterling Integrator to easily organize your trading partners into groups so that you can quickly track related documents, trends, and other supply chain information for the group as a whole.

Meeting Regulatory and Industry Mandates

Regulatory initiatives and industry mandates such as AS3 document transport, HIPAA compliance (Health Insurance Portability and Accountability Act), SWIFT, RosettaNet implementation guidelines, and EBICS are some of the business drivers that require advanced integration.

In the United States, if you are an organization in the utilities, logistics, or financial industries, you are likely facing deregulation concerns. In general, organizations in Europe and Asia, as well as in the U.S. automotive industry, must be ebXML-compliant. And U.S. federal mandates related to corporate accountability, such as the Sarbanes-Oxley Act, may be increasing your internal and external application and partner integration requirements.

Sterling Integrator enables you to rapidly modify your processes or deploy new technology when the requirement arises.

Meeting Integration Challenges

Integration challenges can be grouped into the following categories:

- Trading Partner Management
- Data Transformation
- Process Automation
- Human Workflow Automation
- Monitoring and Managing Processes
- Enterprise Integration

Trading Partner Management

In order to be competitive, you must be responsive to the constant changes occurring within your trading partner community. Changes driven by new requirements such as new data formats and communication protocols, new business exchanges, and a broad range of partners varying in size, type, and sophistication, require your organization to be flexible and adapt to changing and varied situations quickly and efficiently.

Sterling Integrator:

- Works over almost any communication protocol, including HTTP, HTTPS, FTP, FTPS, SMTP, SOAP, EDIINT (AS1, AS2, and AS3). Therefore, you have the flexibility to respond to changes in communication methods (async and bisync communications are supported through Connect:Enterprise interoperability)
- Provides scalability to meet fluctuations in transaction volume
- Enables end-to-end order visibility for tracking transactions throughout the lifecycle of an order and ensuring that orders are never lost
- Provides mailbox store-and-forward services
- Interfaces with B2B exchanges, marketplaces, and services such as RosettaNet, Sterling Information Broker[®], and the GSX and IBM networks

You can also use it to facilitate e-business with your trading partners for a vast assortment of transactions, including EDI, e-mail, and reliable bulk file management. You can build human intervention points, such as approvals, into your processes and set up self-service access to information across trading partner systems. You can also:

- Reduce or eliminate the requirement to re-enter key data
- Speed up order reconciliation through automation
- Reduce the cost of integrating trading partners

The following figure illustrates the path that the data takes from your applications to your trading partner community. Enterprise Application Integration (EAI) components and B2B services facilitate the transfer of information, while the processing engine, the Business Process Engine, manages everything.

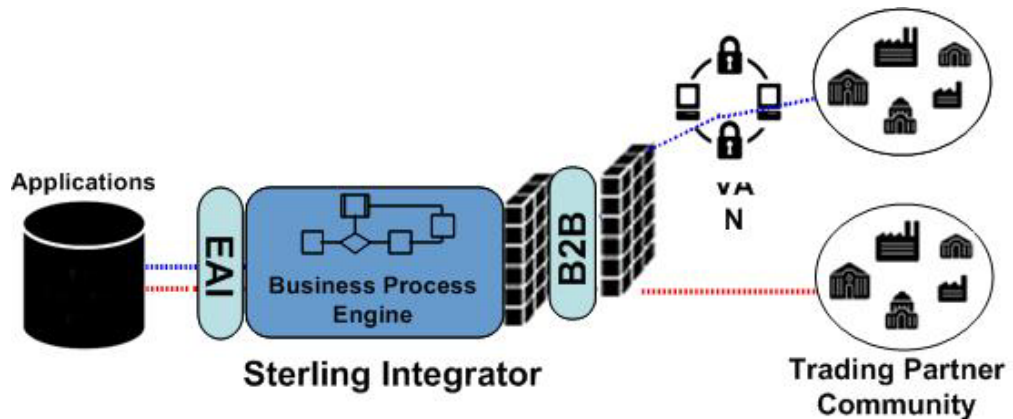

Data Transformation

Data transformation is the cornerstone of electronic commerce. With Sterling Integrator, you can manipulate data transformation easily. Supported data formats include Electronic Data Interchange (EDI), positional, variable-length-delimited, Japanese Center for Informatization of Industry (CII), and Extensible Markup Language (XML). Using Structured Query Language (SQL), Sterling Integrator can read, write, and update databases.

Sterling Integrator provides sophisticated transformation logic, including if-then-else, boolean logic, conditional operators, look-up tables, user-defined constants, and user exits.

With support for pre-existing and emerging standards in place, you are prepared to meet new requirements as they develop. You can add complexity to existing structures and build new structures into your translation processes using the configurable components.

A Java translation engine provides scalability, fault tolerance and reliability—all of which powerful assets for sophisticated translations. You can respond quickly to changing translation requirements, improving your quality of service through data integrity.

A graphical user interface is provided for the design and collaborative development of data transformation maps. This interface simplifies map creation by enabling you to build translation maps using point-and-click technology. You can reuse the maps that you have already created, cutting data management costs.

Process Automation

You can achieve your automation goals with reusable code that you can configure through the easy-to-use graphical interface.

The Graphical Process Modeler (GPM) depicts predefined system activities using icons, enabling you to easily create links between them to design comprehensive process flows, called business process models.

The GPM converts your graphical representation of business processes to well-formed business process code, saving you the effort of writing code. Your process models are immediately executable, and the process development cycle time is short.

You can perform a search in the system by process, partner, and document content, and can configure persistence into your processes to ensure message delivery.

The following figure shows a simple sample business process model as it will be displayed in the GPM.

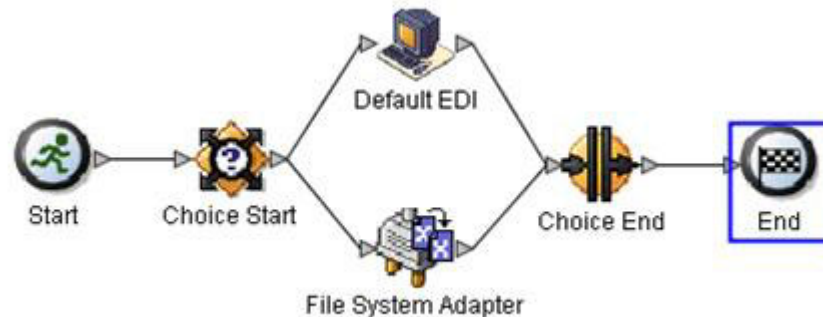

Human Workflow Automation

To reduce costs, you must replace manual intervention points in your business processes with automated capabilities. Exception management such as escalation and transaction reconciliation, error handling, and content-based routing are classic examples.

With Sterling Integrator, you can create online forms for reviewing, entering, and otherwise interacting with the data in a process. You can even enable your business partners to access custom-created online forms, so that they can interact as part of your process.

For example, you can create self-service payment, order, and shipment status forms, and use them to improve partner and customer collaboration through secure, selective data sharing online.

Monitoring and Managing Processes

Even when your processes are integrated, day-to-day monitoring and management of activities may be complicated and redundant. To eliminate these complications and get maximum value from your integration technology, you need a central hub from where you can ensure end-to-end transaction visibility, configure and manage operations and transactions.

The browser-based interface offers a central hub for managing your monitoring and maintenance tasks. The interface enables you to perform the following monitoring and tracking tasks:

- Track processing history
- View transaction details and real-time system events
- Obtain processing state information
- Create reports specific to your requirements

The console enables you to perform the following tasks to manage processes and the entities related to them:

- Configure system-processing parameters
- Manage data transformation maps
- Create and manage business process models

- Automate alerts
- Configure security, including perimeter services
- Start, stop, and resume processes
- Configure user and trading partner accounts
- Configure logging and auditing levels
- Set up communication configurations

To provide full-spectrum transaction visibility, Sterling Integrator interoperates with other enterprise system management products, including IBM Tivoli, BMC Performance Manager, and Computer Associates' Unicenter.

The Dashboard interface design makes monitoring and managing trading partner communities intuitive by displaying operational statistics such as database use and log entries at-a-glance, and enabling administrative activities, all from one location. According to your requirements, you can modify the name and theme of a page, and pick and choose from a range of information components called portlets to determine which elements must be displayed on a page, and in what configuration. For more information about the Dashboard, see *Dashboard Interface* topic.

Enterprise Integration

Sterling Integrator supports your end-to-end integration goals by enabling you to integrate applications using batch, synchronous, and asynchronous processes.

Sterling Integrator:

- Allows you to incorporate messaging, human interventions, and file and database activities within your integrated business process models
- Supports real-time requests and reply processing
- Supports high-volume batch processing
- Offers non-invasive, rapidly deployable messaging and data storage systems, as well as application adapters to facilitate enterprise resource planning goals
- Can be easily integrated with Simple Network Management Protocol (SNMP) network management, Lightweight Directory Access Protocol (LDAP) directories, Web services, and more

The following figure shows the processing engine coordinating the communications to your trading partners through communication adapters. This is based on data transformation and processing involving other integrated systems, all accessed through adapters.

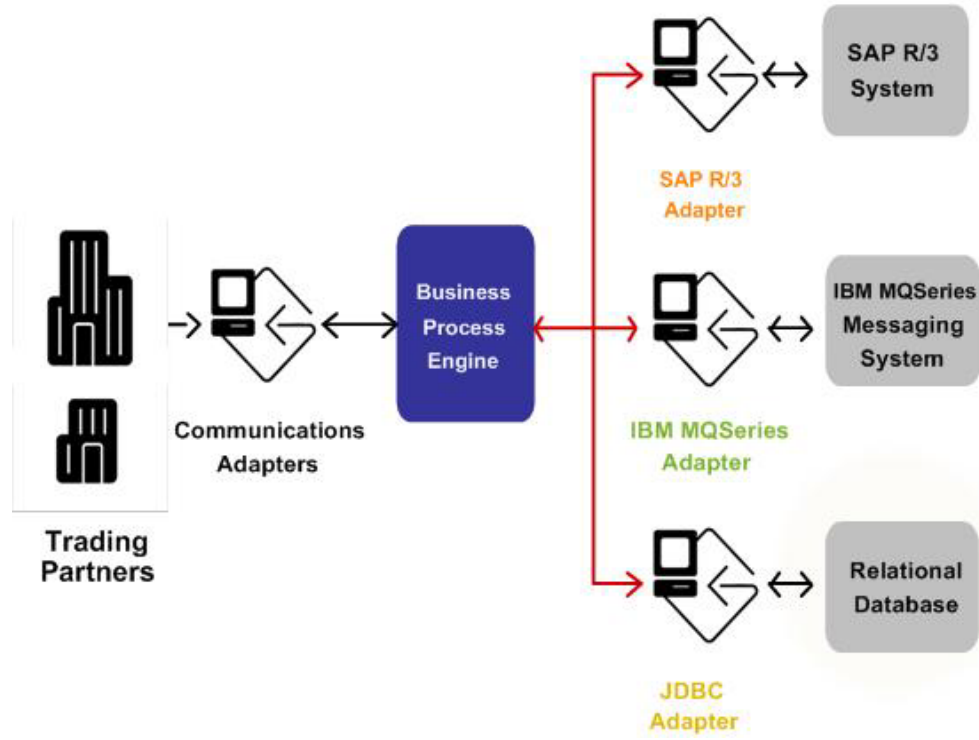

Chapter 2. The Sterling Integrator Advantage

The Sterling Integrator Advantage

Sterling Integrator is designed to be configured strategically around the specific processes crucial to your company's success. Its systematic and managed approach supports your integration requirements for both transaction-oriented and batch processes, and works with both pre-existing Electronic Data Interchange (EDI) protocols and Internet-based XML protocols. You can enable your existing systems to integrate past, present, and future technologies and practices

Business Process Approach

The Sterling Integrator approach to integration centers around business process management. A business process is a goal-driven, ordered flow of activities that accomplishes a business objective. Using Sterling Integrator, you integrate the activities that make up your company's business processes. Common examples of such activities include:

- XML, EDI, and proprietary file translation, transformation, and filtering
- Human interaction through a browser interface (such as reviewing and approving data)
- Content-based routing of messages
- Data publishing
- Extended process models that integrate the execution of a B2B protocol, such as AS2, with enterprise system integration, such as invoking the SAP adapter

You can create and coordinate activities into business process models, extending the automation of your processes and increasing the value of your e-business operations.

An example of a simple business process is the fire-and-forget publishing of a business event to a group of interested participants. The steps that comprise the process trigger the process and the subsequent publishing of the event to the interested parties.

A complex business process might require multiple interactions among many applications in a start-and-stop, request-response mode, along with human interaction, occurring over a long period of time.

For more information about how to manage business processes, see the *Business Process Engine* topic.

Modular Design

Sterling Integrator is designed around a core transaction engine, which orchestrates your message exchange, routing, translation, and other processes. This design enables you to add capabilities for specific activities to the core, as required, promoting enhanced flexibility in adapting your system to changing requirements.

Examples of components that you can add include B2B services, adapters for specific applications and technology, and a Web-based forms-creation component that lets you create interfaces for human interaction. Licensing for the various

components is per-module, making the process of adding or combining components simple. You can customize your solution to suit your requirements.

Building on Your Existing Assets

Sterling Integrator components not only work together, they work with the systems you already have in place, including the Gentran family of products and Connect:Direct[®], Connect:Enterprise[®], and Sterling Information Broker[®]. By tightly coordinating your systems streamline their processes, you can save on costs, which you can apply to your core business or to additional integration-related components.

The compatibility of Sterling Integrator with your existing systems, combined with its modular design, drastically reduces the standard complications associated with large-scale systems changes.

For more information about interoperability with Gentran:Server and Connect products, see the *Interoperability with Gentran:Server and Connect Products* topic.

Leveraging Industry Standards

To meet your ongoing integration goals and business automation directives, you must rely on software that works within the accepted industry standards.

The Sterling Integrator platform is built on industry-accepted data formats, communication protocols, workflow modeling, and security. This design structure maximizes interoperability between systems and trading partners, thereby providing the following benefits:

- Reducing integration complexity and cost by minimizing the need for custom programming and re-training support staff
- Supporting the rapid and secure delivery of emerging solutions for collaborative processes between businesses and business units

Sterling Commerce has a long history as a leader in standards development. Sterling Commerce was a leading participant in the development of the EDIINT AS1 and AS2 protocol designs (providing interoperations testing), and was instrumental in the development of RosettaNet, ebXML, and business process modeling initiatives.

The following table details the industry standards upon which Sterling Integrator's processing is based:

Design Level	Sterling Integrator Standards
Process modeling	Business Process Modeling Language (BPML, an XML-based meta language), XPATH (a non-SML language that can identify parts of XML documents for later use), XSLT (Extensible Style Language Transformation)

Design Level	Sterling Integrator Standards
Integration	<ul style="list-style-type: none"> • B2B management: XML, EDI (EDIFACT, ANSI X12), B2B protocols (ebXML, EDIINT), RosettaNet • Internet transports: Hyper Text Transfer Protocol (HTTP), Simple Mail Transfer Protocol (SMTP for e-mail), File Transfer Protocol (FTP), SOAP, AS1, AS2, AS3 • Security: Secure Sockets Layer (SSL), X.509, S/MIME, XML DSIG (digital signatures and data encryption) • Open standards: XPATH, XML schema, XSLT • Network management: SNMP (Simple Network Management Protocol), which enables exchange of information between network devices
Low-level infrastructure	J2EE Technology: JMS, JNDI, JDBC, and RMI

Robust Security Model

Sterling Integrator's security model enables you to create customized security and facilitate related user-based routing within a process, based on the security settings for a user.

You can designate entities (such as a trading partner) and groups (users, depending on their role), and assign them the permissions that you configure.

The security standards supported include:

- AS2 and AS3 transport
- Digital certificate management
- Document encryption in the database
- SSL for HTTP
- SFTP and FTP server capability
- A trading partner-specific process firewall
- Digital signatures with ebXML messaging
- User ID and password authentication for user interface applications
- A service that revokes compromised digital certificates

Perimeter Services

Sterling Integrator also includes a perimeter server communication management component. A perimeter server is a single entry point installed in a demilitarized zone (DMZ) to manage communication flows between a perimeter network and Sterling Integrator transport adapters.

A perimeter network is a computer network configured to stand between a secured internal network and an unsecured external network, as an additional layer of security. A perimeter server communicates with Sterling Integrator through special perimeter services, which enable an adapter to communicate through an internal firewall with a perimeter server within the DMZ.

Perimeter servers enhance security by moving security threats away from your secure network and data.

Full Process Recovery

During the execution of a business process, at every step, Sterling Integrator maintains the status of the process, as well as the current version of the business data associated with the process step. Whenever a business document associated with a process changes (such as with translation), a copy of the document is maintained. This ensures full process recoverability, long-standing processes, and efficient problem diagnosis.

Connecting People to Data with Web Extensions

Sterling Integrator's optional Web Extensions component enables human interaction with business data. With Web Extensions, you can create and customize pages that users can access over the Internet to interact with data. The browser-based technology works hand-in-hand with other components. For example, the Business Process Engine component can route invoices to a manager for approval, while a Web Extensions form created for your process presents the invoice in a browser window. Web Extensions forms can also be used to enable input and data validation prior to sending data to the next point in its process.

You can use Web Extensions to extend B2B services to small or non-integrated business partners by letting them complete simple forms that generate electronic documents.

Interoperability with Gentran:Server and Connect Products

Sterling Integrator operates in conjunction with your existing Gentran:Server products. Alternatively, you can import pre-existing EDI data and let Sterling Integrator process the EDI data. Irrespective of the scenario you use, you will find features and functions that help you achieve your EDI-processing goals. Interoperation between Sterling Integrator and Connect:Enterprise UNIX or Connect:Direct enables easy communication between your company's internal applications and with external business partners.

Gentran:Server UNIX

You can manage all your Gentran:Server UNIX operations from the Sterling Integrator administrative console. You can use the Sterling Integrator's operations, monitoring, and trading profile tools to perform the following Gentran:Server UNIX functions:

- Starting and stopping Gentran:Server UNIX data managers
- Viewing Gentran:Server UNIX data manager statuses and log files, and processing the log files
- Monitoring and searching for data processed in Gentran:Server UNIX
- Importing trading partner information from Gentran:Server UNIX into Sterling Integrator.

Gentran:Server Windows

Current users of Gentran:Server Windows can use their data concurrently with Sterling Integrator.

The Sterling Integrator trading profile tool enables you to import Gentran:Server Windows trading partner information into Sterling Integrator.

Sterling Integrator enables data exchange between Gentran:Server Windows and Sterling Integrator using the Gentran:Server Windows adapter. However, before you exchange data, you must install and configure the adapter.

Connect:Enterprise UNIX

Connectivity between Sterling Integrator and Connect:Enterprise UNIX lets you exchange business documents and data between the two applications in a near seamless environment. You can also create automated business processes to intelligently interact with your enterprise systems, eliminating the need to manually create customized scripts to handle processing in your enterprise systems.

Sterling Integrator and Connect:Enterprise UNIX interoperability also provides end-to-end file processing management and visibility, and access to a broader set of business-level protocols including ebXML, SOAP (Web services), GDSN, and RosettaNet.

Connect:Direct

Connect:Direct securely transfers large files between the applications within an enterprise and with external business partners. It also allows for basic activities such as running jobs or processes on remote business partners' servers.

In effect, Sterling Integrator becomes a Connect:Direct node. Connectivity between Sterling Integrator and Connect:Direct enables you to:

- Securely copy large files and exchange data between the two applications in a near seamless environment.
- Create sophisticated, automated business processes to intelligently act on the data sent to Sterling Integrator.

Additional Components

For a complete list of the available Sterling Integrator components, see the Sterling Commerce Self-Service Web site at www.productupdates.stercomm.com.

Use your CD key to view the list of packages.

Chapter 3. Getting Sterling Integrator to Work for You

Getting Sterling Integrator to Work for You

With a high-level understanding of the key Sterling Integrator components and their capabilities, you are ready to identify the process improvement opportunities within your organization.

For information about the process you must follow to implement Sterling Integrator, see Implementation Overview topic.

For a features overview and description of the Sterling Integrator architecture, see Architectural Overview topic.

Identifying Process Improvement Opportunities

Determining the configuration strategy that matches your organization's requirements requires careful planning and an understanding of the complications that you want to overcome.

As you work with Sterling Commerce to determine your implementation strategy, you will determine the areas in which you must make changes to processes in order to maximize revenue and lower costs.

The following table describes the problem areas that you can consider making changes in:

Problem	Description
Manually handling information or processing steps that are definable and repeated	Any information-based task that can be defined can be automated. Automated tasks are typically performed faster and with fewer errors than manual tasks. Definable tasks that are repeated with sufficient frequency and quantity are almost always less expensive after automation.
Information stored and transmitted on paper	This requires either key-entry into the business application that will process it, or manual processing followed by key-entry of the results. Key entry and manual processing are slow and error prone, and are therefore an inefficient use of human resources. The delays and high rate of errors raise expenses. Errors and missed opportunities can cause negative effects further down the process stream.
Information in a non-codified form (such as text)	Non-codified information must be manually processed.

Problem	Description
Process obstructions	<p>Any point at which a process slows down or stops because of some aspect of information movement, presentation, or processing, presents an opportunity for improvement. Examples of process such points include:</p> <ul style="list-style-type: none"> • Waiting to obtain information from another source. • Spending extra time finding information. • Slowing down because of information that is in a form that cannot be used. • Actions pending because of information processing by humans. • Time spent finding, researching, and correcting an information-based error.

After identifying the problem areas that will benefit from automation and integration improvements, analyze which of the potential changes will most significantly improve your organization's target performance measurements, and make those the priority.

Sterling Commerce Resources

Sterling Integrator

Sterling Commerce offers the following resources to assist you with your implementation:

- Consulting services to assist with analysis, design, and planning
- Education in the form of training programs and documentation
- Implementation assistance for developing and testing your system
- Community-enablement services to help integrate your business partner community
- Live and online Customer Support, as required, for sustaining your solution

The array of services and support offered by Sterling Commerce helps to accelerate your installation and deployment phases, transferring knowledge from our integration specialists to your staff and reducing the risk of project delays.

When you realize your business results quickly, you can focus on maximizing the returns on your investment.

Chapter 4. Architectural Overview

Architectural Overview

Sterling Integrator's architecture is built on a multi-level platform, which enables efficient development of new features. This design enables you to respond rapidly to business and technology changes.

The Sterling Integrator platform:

- Supports a business process management approach to integration
- Provides enterprise scalability, manageability, and security
- Delivers non-invasive integration with pre-existing systems
- Supports emerging e-business standards frameworks
- Enables rapid change management and deployment
- Enables multiple interaction styles
- Offers a diverse, open-ended functionality set that you can extend in numerous ways
- Facilitates interoperability of integrating software
- Promotes widespread adoption of key industry standards
- Enables data transformation and data management activities that are the cornerstone of your processes

The following figure illustrates Sterling Integrator's architecture.

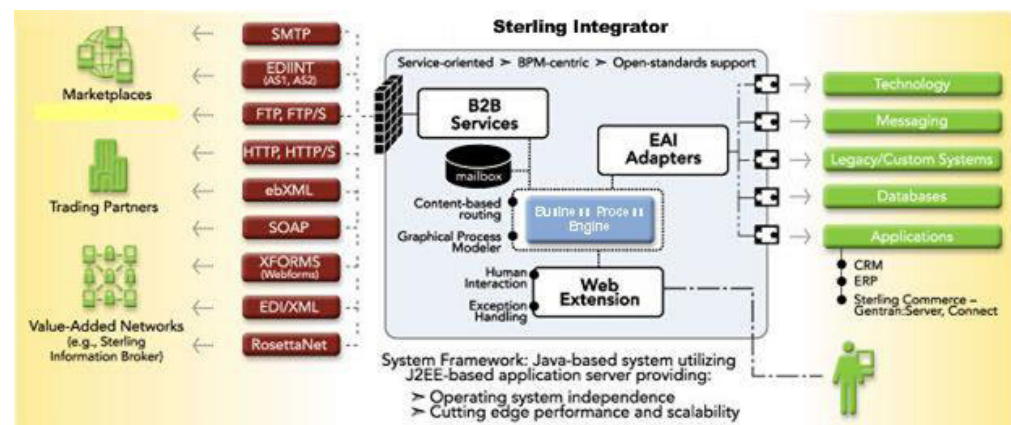

The figure depicts a Sterling Integrator system using many B2B services and EAI adapters. Your configuration will use only the services and adapters that are required for integration activities. The figure also shows a mail box component and integrated human interaction points through Web Extensions, which you may or may not decide to employ.

The following steps explain the progress of a sample process moving through this architecture:

1. A trading partner sends a document such as a purchase order through a B2B transport protocol (SMTP, EDIINT, FTP, or HTTP) to your organization, using the appropriate service.

2. The arrival of the document triggers the business process you have configured for the document, and possibly, for this specific trading partner. The Business Process Engine manages the progression of steps in the business process.
3. The business process de-envelopes the document to obtain instructional information such as routing directions, in addition to the body content of the document.
4. Based on the data in the document, the business process progresses to the next step. This might include passing the document (through EAI adapters) into one or more internal applications such as:
 - A PeopleSoft™ order management system
 - A Web Extensions application (online form) for human interaction with the data, such as a manager's review and approval prior to routing to the next step
 - An accounting system for credit verification, and then on to an order management system
 - A mailbox application to store the data until a scheduled time when the business process progresses to the next activity
5. The process may end here or it may include additional steps, such as adapter-assisted interaction with one or more enterprise systems, to generate a response document to be returned to the trading partner, again using B2B transport services.

For information about the various components and features and the ways they interact, see the following topics:

- For technical information about system design, see the Sterling Integrator Technical Framework topic.
- For information about the functions supported by the architecture, see the Sterling Integrator's Functional Framework topic.
- For information about the Business Process Engine, see the Business Process Engine topic.
- For details about the core components of Sterling Integrator, including B2B services, EAI adapters, and Web Extensions, see the Fundamental Components of Sterling Integrator topic.

Sterling Integrator Technical Framework

Sterling Integrator is written in Java™ and can run in an application server-independent configuration or alongside an application server such as BEA WebLogic™, and JBoss™ products. Sterling Integrator uses Enterprise JavaBeans (EJB) adapters when communicating with an application server.

Application server independence is a valuable configuration because:

- It requires fewer product prerequisites, which may reduce your total costs.
- It enables greater flexibility in deployment options.
- It works well if you use J2EE application servers that Sterling Integrator does not support, or if you have a policy of not deploying a different application server in any production environment.

There is no difference in the functionality between Sterling Integrator used in an application server-independent configuration and Sterling Integrator used alongside an application server. Integrating with an application server requires the use of an adapter (EJB adapter), which is included with the product.

The following display shows a simplified view of the system architecture:

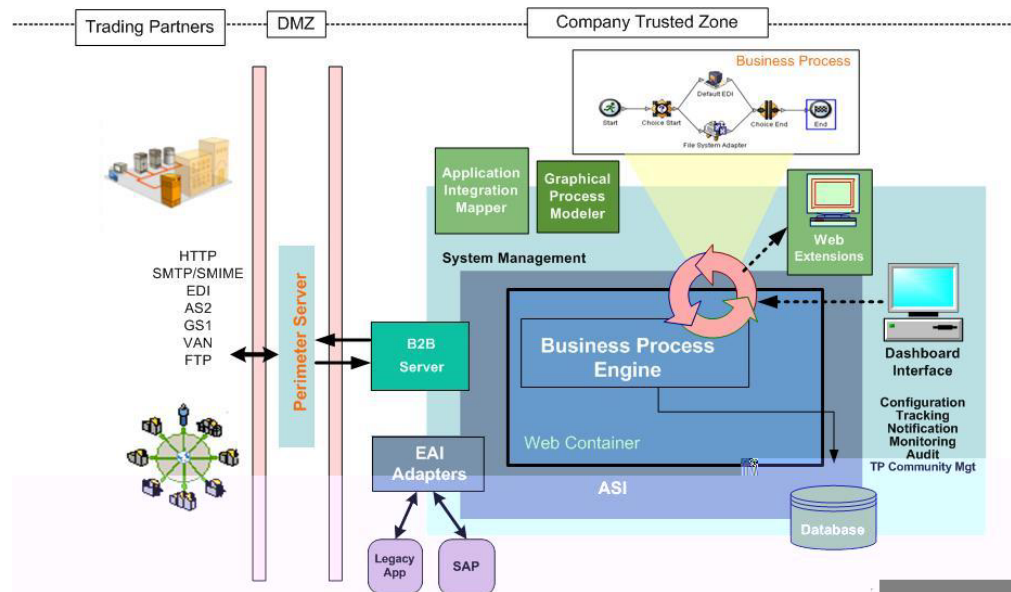

Think of Sterling Integrator as a standards-based business process management system consisting of a toolbox of integration components, on top of a J2EE infrastructure. The integration components include the mapper, Graphical Process Modeler (GPM), B2B services, EAI adapters, and Web Extensions. The J2EE framework enables many key aspects of the Sterling Integrator system, including:

- Standards-based interfaces for common middleware functionality
- Support for multiple operating systems, including UNIX, Windows NT/2000, Linux, and IBM z/OS® and iSeries®
- Load balancing
- Fault tolerance
- An advanced EJB object-oriented development and deployment environment that facilitates reuse of existing component software, easier change management, and easier application knowledge transfer
- Scalable component clustering
- Ability to create complex process flows

Sterling Integrator's Functional Framework

The Sterling Integrator framework uses a Business Process engine as its core transaction engine to support all data management, translation, transformation, and routing services. This framework supports:

- Advanced parsing, filtering, and content-based routing through the use of XPath parsing and filtering technology
- A base set of services that you can use and extend as your requirements evolve and new technologies emerge (custom services can also be developed to support the unique requirements of your organization)

Other Sterling Integrator foundation functions that complement the business engine are:

- An administration layer that is a single point of access for configuring, monitoring, and managing the system and its integration activities
- Tracking services that trace the flow of information even as a business process runs

- Monitoring, which enables you to view business processes as they run
- Logging, which records system events such as user interaction, administration, and the execution of business processes
- Event notifications that provide alerts in response to events or exceptions, using mechanisms such as e-mail or pagers
- Archival storage of business process data

Fundamental Components of Sterling Integrator

This section describes the following fundamental components of Sterling Integrator:

- Business Process Engine
- Services and Adapters
- Graphical Process Modeler
- Mapping and Data Transformation Components

Business Process Engine

The Business Process Engine is the core component supporting the Sterling Integrator business process approach to integration. The Business Process Engine enables high-performance flexibility, extensibility, and a consistent environment for deploying EAI, Internet B2B, EDI, and business process management projects.

The Business Process Engine is Java-based. For information about the technical framework of Sterling Integrator, see the Sterling Integrator Technical Framework topic.

Integration Activities Performed by the Business Process Engine

The Business Process Engine performs integration activities, known as services.

Nearly any kind of activity can be a service in Sterling Integrator. All such services achieve some predefined type of integration activity. Examples of service activities performed by the Business Process Engine include:

- Communicating with external applications or middleware (using special services called adapters)
- Performing data manipulations, such as translation, transformation, splitting, and joining
- Routing data based on content or other criteria
- Publishing data to interested subscribers, which may trigger a new business process or allow a running process to continue
- Execution of one or more B2B protocols
- Starting a business process
- Performing operations on SQL (Structured Query Language) database tables
- Enabling human interactions within an otherwise automated process

For more information about the services in Sterling Integrator, see the *Services and Adapters* topic.

Understanding Business Processes

The services that the Business Process Engine runs are configured within defined business process models that you create and modify within the system.

A business process is a series of linked software (and possibly human) activities that accomplishes a business goal. The activities are called services, the modules of work that comprise business processes. The services must complete for a business process to run successfully.

A business process model can be a simple linear configuration, or contain one or more decision points requiring human or system determination of the next steps in the process.

In the following conceptual figure of a business process, an oval represents an activity, and a diamond represents a decision point:



The high-level process for creating a business process model involves:

1. Analyzing your business requirements
2. Determining which services, adapters, and components you must involve to accomplish your goal
3. Configuring the services and adapters used in the business process
4. Testing the business process

Business Process Modeling Language

The Sterling Integrator Business Process Engine runs business process models that have been created using *Business Process Modeling Language (BPML)*, which is an XML-based language for describing business processes. It was developed by the Business Process Management Initiative (www.bpmi.org).

You can create business process models in several ways:

- Graphical Process Modeler (GPM).
For information about the GPM, see the Graphical Process Modeler topic.
- A simple text editor
- Any graphical editor that can export the XML format to Sterling Integrator

Unless you are proficient in the use of XML and BPML syntax, use the GPM to create your business process models.

Business Process Flow

The Business Process Engine automatically selects the appropriate business process model to run when data enters the system through an input adapter. When an input adapter receives data from an external system, the Business Process Engine locates the appropriate business process or processes to call, and starts the process or delivers the incoming data to the appropriate process that is already running.

The following is an example of how the Business Process Engine executes the steps in a business process as a document progresses through Sterling Integrator:

1. Sterling Integrator receives the business message or document through an adapter.

2. The Business Process Engine determines which service to start next, and starts the service, according to the content of the document.
3. The adapter places the message or document and other appropriate process state information in a queue for the appropriate service in the selected business process.
4. The appropriate service retrieves the initial business process state information from the queue and processes the next step in the business process.
5. Each service in the business process updates the business process state information, and creates a copy of the related data or pointers to the data for process recoverability.
6. An adapter sends the modified business process state information, with the data, to a specific application.

For information about how the system maintains process state information, see the *Full Process Recovery* topic.

Services and Adapters

A *service* is a set of instructions that the Business Process Engine uses to perform an activity in a business process. *Adapters* are services that connect the Business Process Engine and other system components to dissimilar systems and applications outside of the Sterling Integrator environment. Business processes can send, pause, retrieve, and fully interact with adapters.

Services and adapters are reusable—you can include them in multiple business process models.

Understanding Services and Adapters

Sterling Integrator includes numerous services. Some are internal system services, while most are external and can be configured by users. Configurable services can be used in business processes for activities such as running pre-existing programs, ERP systems, Perl (Practical Extraction and Report Language) scripts, Java code, decision engines, defined subprocesses, or virtually any program. The interface includes wizard-driven configuration and deployment steps to make the setup simple.

There are three service types:

- Internal - Accepts parameters and produces results, but does not directly interact with outside systems.
- Input - Receives data from outside systems.
- Output - Sends data to outside systems.

Input and output services are generally called *adapters*. The adapters connect to systems and applications outside of the Sterling Integrator environment. Adapters can listen for remote calls and then start the business processes. They can be used to start business processes or at any point in the business process.

Another type of input/output service is a *human interaction service*. Human interaction services enable humans to interact with a business process; for example, using a Web browser to approve data as a step in a business process.

For a list of the functional types of services and adapters in Sterling Integrator, see the *Service and Adapters Category List* topic.

Standards, Foreign Language, and Data Type Support

Sterling Integrator services are developed using industry-accepted specifications for data formats, communication protocols, workflow modeling, and security in order to maximize interoperability between systems and trading partners.

Supported standards include:

- Internet transports
- Cryptographic services
- Document-enveloping formats
- Document formats
- Business process sequencing
- Web services

Because Sterling Integrator is built on a Java code base, and Java supports Unicode, which is a universal character-encoding scheme for written characters and text, the programs with which your processes will interact can be written in nearly any language. Virtually any file-based, message-based, or stream-based data type are also supported.

Adapters

Adapters either receive input from or provide output to outside systems. Adapters provide noninvasive integration with Enterprise Resource Planning (ERP), Supply Chain Management (SCM), Customer Relationship Management (CRM), other packaged applications, enterprise applications, communication protocols, messaging solutions such as IBM WebSphere[®], and databases.

The following process summarizes the way adapters work within a business process:

1. The business process progresses to the application adapter step.
2. The adapter calls a third-party application to perform an activity.
3. The system records the modified state (context) of the process and related data.
4. The business process continues to the next service or adapter.

Service and Adapters Category List

The following table lists Sterling Integrator services and adapters according to the functional category they belong to:

Service and Adapters Category	Description
Application adapters	Connect to packaged business applications that are external to Sterling Integrator, including ERP, CRM, supply chain management, and procurement software.
BPML activity services	Support the run-time execution of functions in a business process model.
Communication adapters	Enable Sterling Integrator to send and receive messages using the standard Internet communication protocols.
Custom services	Developed and configured by your software developer to use with Sterling Integrator.

Service and Adapters Category	Description
EDI services	Transaction processing for EDI transactions, including de-enveloping, enveloping, and functional acknowledgment generation.
Internal services	Support the general run-time environment and are not user configurable.
Internet B2B standards services	Manage data from your firewall to your trading partners by running interoperable Internet business sequencing protocols such as EDIINT, SOAP, RosettaNet™ Implementation Framework (RNIF), and Electronic Business using eXtensible Markup Language (ebXML).
Messaging adapters	Enable Sterling Integrator to send messages to and receive messages from remote messaging queues
Sterling Commerce adapters	Connect to other Sterling Commerce products.
System services	Support the general run-time environment (these are user configurable).
Translation services	Translate or transform data using maps created with the Map Editor tool.
Web Extensions services or “human interaction” services	<ul style="list-style-type: none"> • Enable human interaction with business processes and support Web services technologies. • Directly start application function calls over the Internet.

Sterling Integrator is flexible and enables you to determine what activities to configure as a service, a business process, or a subprocess. For instance, you could implement ebXML support in the form of multiple activities linked together in a business process, or write a single service. This flexibility ensures that you can easily adapt to new requirements.

Visit the Sterling Commerce Self-Service Web site at <http://www.productupdates.stercomm.com> for the full list of services and adapters available.

Graphical Process Modeler

Business process models define how the Business Process Engine executes the activities in a business process. Creating business process models for the system to follow is the central activity around which your operations are based on.

The Graphical Process Modeler (GPM) enables you to create business process models using drag-and-drop technology. The GPM depicts the services you include in your business process models using icons. Each icon translates into multiple lines of code.

You can drag icons from a pallet of options representing the services and BPML constructions (such as choices, start and stop, and so on) that you require on to the workspace in order to create your business process model. When you save the

business process model, the GPM converts the graphical representation into well-formed and valid Business Process Modeling Language (BPML).

For information about how the Business Process Engine runs business processes, see the *Business Process Engine* topic.

Examples of GPM

The following figure shows GPM icons representing the beginning and end points of a business process model:



The following figure shows some of the GPM icons representing specialized services:



In the GPM interface, a simple business process model might look like this:



The following is an example of a more complicated process depicted in the GPM:

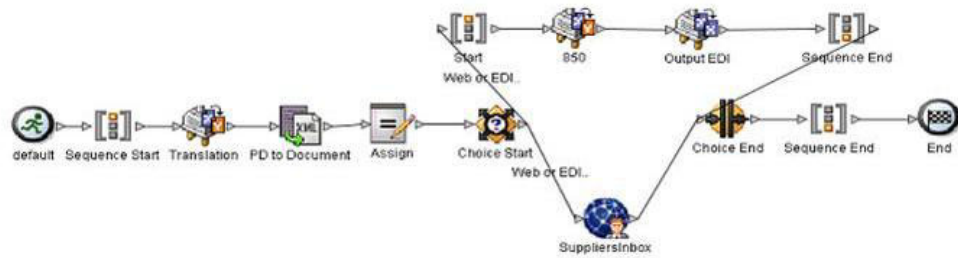

You can reuse an entire process model or a part of it to create new or modified versions of existing models.

Business processes can start other processes and link to subprocesses.

Mapping and Data Transformation Components

Sterling Integrator manages data translation and transformation of complex flat files that are in positional, fixed length, and variable-length delimited formats, supporting both standard and extended rules.

It translates data according to the instructions you provide in the form of translation maps, which you create and manage using the Map Editor tool. A translation map specifies how data in one format relates to data in another format.

Using the JDBC adapter, data, such as the following, can be input or output to databases supporting Java Database Connectivity (JDBC):

- Tables defined in translation maps
- Structured Query Language (SQL) queries, stored procedures, and stored functions

How Translation Works

From a technical perspective, *translation services* perform run-time translation based on the translation maps you have created, using translation objects and XML encoder objects to translate data from one format to another.

The translation objects (files with a .txo extension) and XML encoder objects (files with an .ltx extension) are the compiled translation maps.

Within a translation process, the services:

- Verify if the document that is received complies with the validation and transformation rules defined for the map.
- Store errors in a report and send these to the business process for appropriate action.

Supported Translation Formats

Sterling Integrator translates data that is in the following formats:

- Positional
- Variable-delimited (including, Comma-Separated Values)
- XML, with full support for XML schemas, DTD (document type definition), and namespaces

- EDI (ANSI X12, UN EDIFACT, Tradacoms, Japanese Center for Informatization of Industry [CII]).

Map Editor Tool

You can create, modify, and compile translation maps using the Map Editor tool. The Map Editor is an offline, Windows-based program that you download from Sterling Integrator. It includes preloaded standards and provides flexibility in mapping complex data transformations.

The Map Editor is built on software from the proven Sterling Commerce Gentran:Server product line. Customers familiar with the Gentran:Server Map Editor do not require re-training.

Translation Maps in Sterling Integrator

Using the Map Editor, you can create data transformation maps for the system to use at run time. You can then include the appropriate translation map and related services in your business process models to configure run-time translation activities.

The Map Editor enables:

- Direct mapping from an input format to an output format (no intermediate format required)
- Mapping any supported input format to any supported output format
- Mapping any field or segment of an input map to any field or element of an output map (for example, fields occurring in the trailer section of an input format can be mapped to header fields in an output format)
- Complex rule-based data mappings
- Custom calculations and data type conversions
- Custom Java code user exits for extended rules enable further customization of map behavior
- User exits that support custom Java code

The Map Editor provides tools that allow you to migrate or convert maps from the Gentran:Server for Windows, Gentran:Server for UNIX, Gentran:Server for iSeries, and Gentran:Basic for zSeries® products.

The following figure is an example of a translation map in the Map Editor:

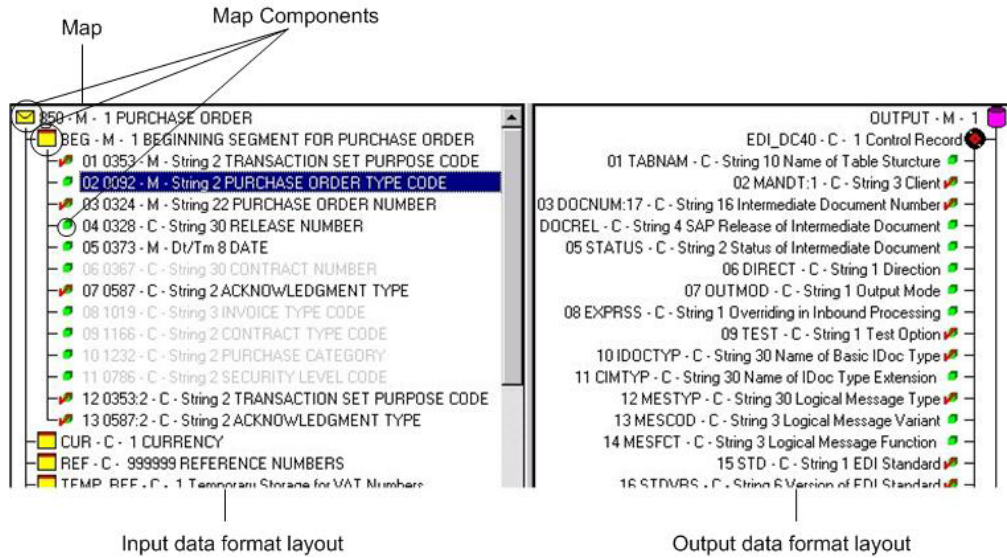

Trading Partner Code Lists

Using the Map Editor, you can create code lists. A code list is a list of values for a field and their corresponding descriptions that you can include in a translation map. You can associate a rule in a translation map so that the system either checks values against the code list or selects a value from the specified list. For example, you can cross-reference a list of internal codes, such as item codes, with corresponding codes from a trading partner. At run time, a map can look up the codes and map the internal item code to an external partner's code (or vice versa).

Without this code list capability, you would have to create such cross-reference functionality using an extended rule, a user exit in an extended rule, or some other custom processing outside of the translation service.

XML Transformation Components

The following table describes some aspects of the XML data transformation support available:

Feature	Description
XML Encoder	<p>An included XML Encoder component provides high-performance translation of the existing application data into XML.</p> <p>The XML Encoder receives a given input format and writes an XML-wrapped output document, without requiring an output map. The XML-wrapped document is then available to a business process for manipulation because the Business Process Modeling Language supports XPath specifications.</p>

Feature	Description
XML Schema Repository functionality	<p>You can maintain a repository for XML schemas and DTDs for use by any appropriate component or service in a translation business process.</p> <p>Schemas are stored in the Sterling Integrator database, much like translation maps. You can store multiple versions of a schema.</p>
XSLT transformations	<p>XML Stylesheet Language Transformation (XSLT) can be enabled with a special service that you can configure in a business process to perform transformations.</p> <p>You can use XSLT for XML-to-XML transformation and creation of static HTML pages from XML documents.</p>
XPath Expression Builder	<p>To ease the creation of XPath-based business rules (content-based routing, content filtering and querying, and calculations), an XPath Expression Builder tool is provided. You can save XPath expressions with a logical name, and re-use them.</p>

The following figure shows the XPath Expression Builder:

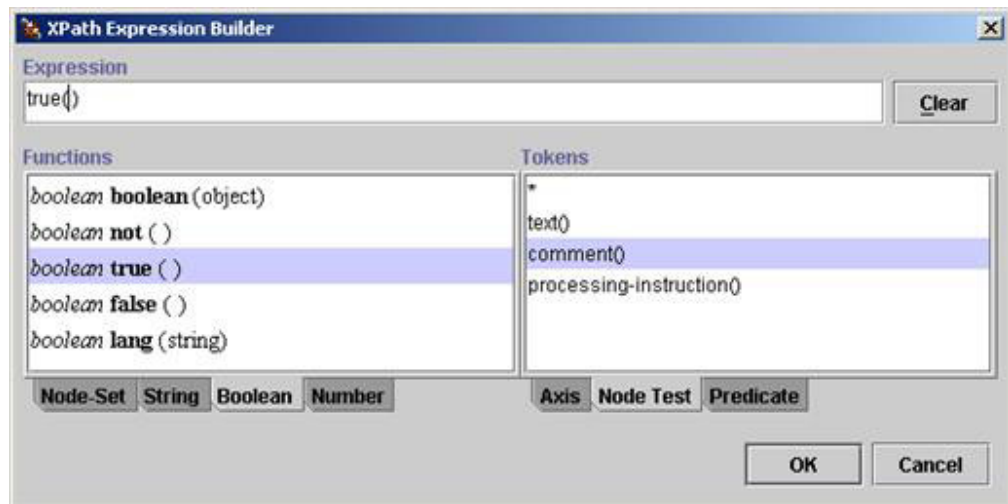

Adapting to Increasing XML Demand

Sterling Integrator has comprehensive support for XML technologies throughout the product. In addition to the items listed in the table under XML Transformation Components, this includes:

- Use of BPML for process model representation
- Web Services support (SOAP adapters)
- WSDL
- RosettaNet Partner Interface Processes (PIPs)
- The ebXML messaging service

- XML Digital Signature support (required by the ebXML messaging service)
- Support for various ERP/CRM application XML interfaces, such as PeopleSoft
- Representation of process state data in a format (using an XML DOM tree) for presentation in a browser window

Chapter 5. Features Overview

Role-Based Security

Sterling Integrator uses role-based security so that you can configure different levels of access permissions for different users within your organization. With role-based security, you can limit a user's access to certain files, business processes, browser-based interfaces, services, and other product features and components according to the permissions you associate with that user's account.

You can define groups associated with a set of permissions, based on user activities or roles. A user account specifies the groups the user belongs to, along with the associated permissions. Permissions allow access to the different modules within Sterling Integrator, and are the foundation of role-based security.

Your user account is linked to an associated Sterling Integrator user name and password. Each time you log in, Sterling Integrator verifies if you are a valid user and grants access only to the appropriate areas, based on the permissions assigned to you in the user account.

Role-Based Security and Message Management

Role-based security helps you manage message queues related to Web Extensions applications. Sterling Integrator uses a user's security parameters when directing messages and documents to the appropriate user. For example, when a business process requires the approval of a user having specific permissions as a step in a business process, a human interaction service obtains the appropriate approving authority's identification from the Sterling Integrator database, where it is stored as the user account data, and routes the document to that person.

Perimeter Server

Sterling Integrator uses perimeter servers to minimize demilitarized zone (DMZ) issues, enhance scalability, enhance the process of handling large files, and improve performance.

A perimeter server is communication management software installed in a DMZ that manages communication flows between a perimeter network and Sterling Integrator TCP-based transport adapters. Perimeter servers help reduce network congestion issues and enhance security and scalability for high-volume environments.

A perimeter network is a computer network configured to function as an additional layer of security between a secured internal network and an unsecured external network. A perimeter server communicates with Sterling Integrator through the special perimeter services available in Sterling Integrator. These perimeter services enable an adapter to communicate with a perimeter server within the DMZ through an internal firewall.

Perimeter servers help reduce network congestion issues and increases scalability for high-volume environments through session and thread management, and enhance security by moving security threats away from your secure network and data. This is especially useful for high-volume B2B gateway environments.

Sterling Integrator perimeter services:

- Work with the complete Sterling Integrator-supported range of transport protocols
- Enable data to get through your firewall while ensuring security
- Support both small and large file size requirements
- Provide a lightweight solution, enabling you to use inexpensive machines in the DMZ.

Internationalization and Localization Support

Sterling Integrator supports multiple languages (internationalization) and multiple regional data formats (localization) by using encoding and XML resource bundles.

Encoding is the representation of data in a particular character set. A character set is a list of characters (letters, numbers, and symbols such as #, \$, and &) that are recognized by computer hardware and software. A string of numbers represents each character.

Sterling Integrator supports specific encoding sets for double-byte character set (DBCS) languages to facilitate correct handling and display of languages that have more than the 256 ANSI-supported characters.

XML Resource Bundles are groups of XML properties packaged together for easy deployment. Sterling Integrator handles displaying screens, messages, and reports in a specific language using resource bundles. Each supported language has a separate XML resource bundle containing the XML properties to localize the date and time, numbers, and currency formats to a specific country or regional format.

Predefined Business Process Models

Sterling Integrator provides a limited number of predefined business process models that you can use when creating models for your own business processes. For a definition of business process and information about how Sterling Integrator uses business process models, see the Graphical Process Modeler topic.

Predefined business process models are preconfigured business process models included with Sterling Integrator for your convenience. These are like any other business process models that you create, in that, each consists of a series of software (and possibly, human) activities that accomplishes a business goal.

The benefit of predefined process models is that you can use them as a starting point when you create your own models by modifying them as required, rather than starting from scratch.

Some predefined business processes are designed to work with specific Sterling Integrator components in conjunction with other business processes; you can use these with the process models you create to save on the configuration steps when you create your process models.

Trading Profile Management

Sterling Integrator uses trading profiles to simplify the configuration of data related to your trading partners.

A trading profile is a collection of records describing the technology, business capabilities, and communication capabilities of a trading partner engaging in e-business with other trading partners.

Sterling Integrator uses the trading profile data to link the trading partner with the business process models you create to handle that partner's documents. The profile describes the partner's role in those business processes as a producer of messages, consumer of messages, or both.

Trading profile settings determine which documents are allowed into or out of Sterling Integrator.

In the Sterling Integrator interface, creating trading profiles is a simple process. The system uses wizard screens to guide you through the process of entering the required information.

Dashboard Interface

The Sterling Integrator interface features a Dashboard that provides system, process, and trading partner information at a glance through elements called portlets that are arranged on the pages.

Much like the Dashboard in a car that displays easy-to-scan information about your speed, fuel level, and temperature, the Dashboard displays information about database usage, cache usage, and log files events. Note for Oracle, the database usage indicator calculates free space used based on Oracle extents.

The following figure displays a Dashboard in Sterling Integrator:

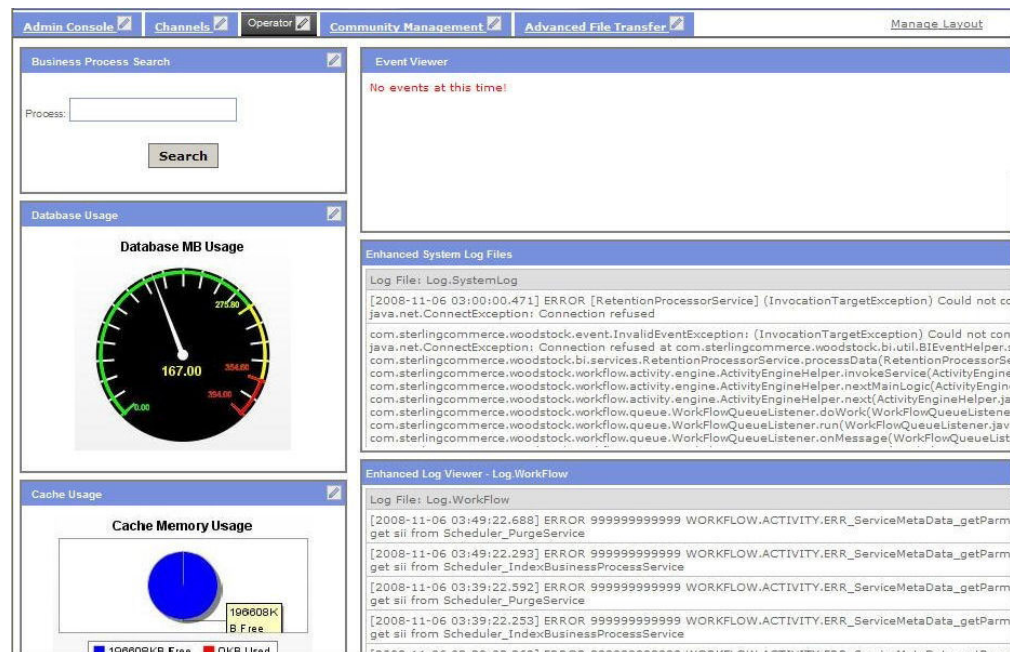

You can customize the Dashboard display to make the process of completing procedures and gathering information quicker and easier than ever before. Four preconfigured display themes are provided. Alternatively, you can create your own theme. For instance, an Operator theme provides an administrator with a quick

look into how the system is functioning by displaying current log and event entries, a database usage indicator, and more.

Additionally, the Dashboard enables you to access specific Sterling Integrator features and functions by effectively minimizing the clicks to get there; for example, you can search for business processes or EDI documents through pre-defined channels.

The Dashboard design offers a variety of benefits. You can:

- Customize a Dashboard to provide individual users a home page that is specific to the tasks they are responsible for, or create your own Dashboards.
- Customize the contents of a page display such that the information that is most important to you is displayed prominently. For instance, you can place monitors showing database usage or trading partner activity at the top of the page.
- Remove the components that you do not require in your page displays.
- Provide a link to the data maintained in locations outside the interface, such as news or stock market reports for display on your page.

Integration with Sterling Community Manager

Sterling Community Manager enables you to organize your trading partners into groups so that you can quickly and easily track related documents, trends, and other supply chain information.

When you create a community, you notify and invite your trading partners to join that community so that you can exchange documents with them. Data from these transactions are then grouped in Sterling Integrator for easy identification and tracking.

You can also join the communities created by trading partners who also use Sterling Integrator. Sterling Community Manager displays your hosted and joined communities and trading partners.

Sterling Community Manager:

- Speeds up the process of ramping up the trading partners associated with a community
- Facilitates reporting
- Enables advanced tracking of documents pertaining to the users in your communities
- Enables you to send notifications to a community as a whole
- Makes it easier for trading partners to join your community

When you install Sterling Integrator, you also get to use the standard edition of Sterling Community Manager. You must obtain the appropriate license to use the enterprise edition of Sterling Community Manager. For more information about Sterling Community Manager, see <http://www.sterlingcommerce.com/Documentation/SCM/HomePage.htm>.

The following figure displays the Community Management interface in the Dashboard:

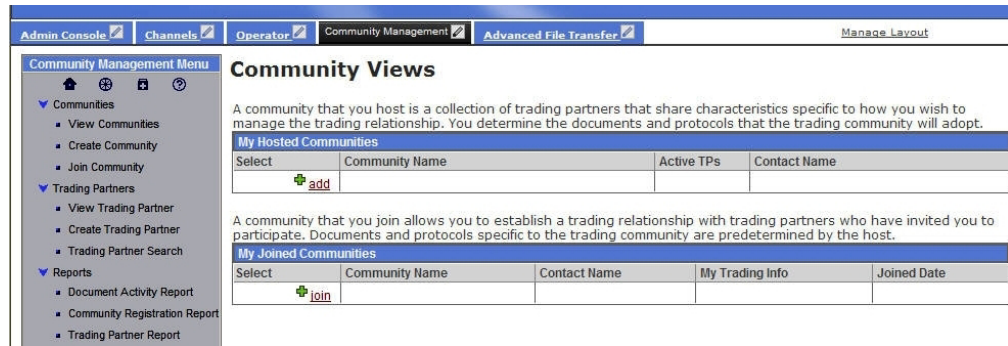

For more information about the Community Management Dashboard interface, see the *Dashboard Interface* topic.

Mail Box Service

Sterling Integrator includes a mail box service that provides store-and-forward capabilities. You can configure this service to organize, store, monitor, and manage trading partner documents and transactions using AS2 protocol (the EDIINT service and the HTTP, and HTTPS communication adapters).

You can use the mail box service for:

- Scheduled batch processing – Sterling Integrator processes all the documents together, based on a schedule that you define.
- Asynchronous document processing – Sterling Integrator processes documents as they arrive in the mail box.
- Document publishing – Sterling Integrator places documents into the mail box for trading partners to access for a specified amount of time.

MESA Developer Studio

Sterling Integrator

MESA Developer Studio is an Integrated Development Environment (IDE) that uses Eclipse software plug-ins. Use MESA Developer Studio to connect with a Sterling Integrator instance for resource access and control of operations, change the template that Sterling Integrator uses, and develop custom services, from within a development environment.

In addition to MESA Developer Studio, the following plug-ins are available:

- MESA Developer Studio SDK – for developing and deploying custom services and adapters.
- MESA Developer Studio Skin Editor – for customizing the look and feel of the Sterling Integrator interface.

Web Extensions

The processes that support your business usually include both human activities and computer-assisted automation. Yet, historically, integration technologies have targeted only the automated aspects of an integration project, such as low-level messaging, file transfer, or EDI. With Sterling Integrator Web Extensions, you can build the human interaction points into your business process models.

Web Extensions Technology

Web Extensions uses advanced XML standards so that you can easily integrate your Web Extensions applications (forms) into your business process models and use Java Server Pages (JSP) to create forms pages.

Technically, Web Extensions is a collection of Sterling Integrator services called Human Interaction services. The Graphical Process Modeler (GPM) depicts these services as icons in the user interface. You include these icons in your business process models by selecting the appropriate service wherever human interaction must occur.

Using Web Extensions

Web Extensions can be used for:

- Supporting human interaction steps within otherwise automated processes, such as:
 - Advanced exception or approval processing before data automatically passes into enterprise systems or out to business partners
 - Expense reporting
- Creating e-commerce Web sites such as an online store with shopping cart functionality.
- Improving partner and customer collaboration through secure selective data sharing by easily deploying partner self-service applications (such as payment, order, and shipment status forms).
- Enabling small trading partners to interact with your business processes by configuring data transformation from the online forms to EDI or XML.

AS2 Edition

The Sterling Integrator AS2 Edition™ combines the strengths of Sterling Integrator with Applicability Statement 2 (AS2) EDIINT technology. AS2 EDIINT is a protocol for securely exchanging data with non-repudiation of receipt over the World Wide Web.

The AS2 Edition is an easy-to-use AS2 EDIINT management solution that you can use with existing EDI or other business document management processes. The AS2 Edition sends and receives documents and interacts with your existing processes.

AS3

Sterling Integrator allows you to exchange AS3 messages with your trading partners either through a custom business process or through a schedule created during contract creation. AS3 systems exchange EDIINT messages using FTP as the transport method. EDIINT messages are either MIME or S/MIME (secure MIME) messages.

Sterling File Gateway

Sterling File Gateway is an application for transferring files between internal and external partners that can be using different protocols, different file naming conventions, and different file formats.

Sterling File Gateway offers point-and-click configuration within a rules-based architecture. Sterling File Gateway provides managed file transfer (MFT) capabilities to handle everything from high-frequency messages and huge periodic file transfers to high volume loads of real-time data while leveraging the power of business-to-business (B2B) integration to move data in transit in a manageable way. With advanced partner on-boarding features, extensive communication channel support and improved business process management, Sterling File Gateway advances operational execution with predefined, event-driven business processes and centralized, enhanced management. It provides end-to-end visibility, auditing and reporting services, and the ability to manage a large number of partners and protocols efficiently.

EBICS Banking Server Module

The EBICS Banking Server Module enables you to transact with partners and users using Electronic Banking Internet Communication Standard (EBICS). Its features include creating and managing profiles (bank, partner, and user), associating partners and users with order types and file formats, assigning user permissions, creating and managing certificates, processing of order data, storing and retrieving profile information, certificates, and messages, managing message flows and transaction flows, and transferring files using secure protocols.

Sterling Integrator is a complete EBICS solution involving a bank, a partner, user management, certificate management, secure file transaction, error recovery, and reporting.

Sterling File Gateway supports EBICS for movement of large and high-volume file transfers, with end-to-end visibility of file movement in a process-oriented and highly-scalable framework that alleviates file transfer challenges, such as protocol and file brokering, automation, and data security.

Sterling e-Invoicing

The Sterling e-Invoicing enables you to use electronic invoices (e-invoices) while also maintaining the requisite legal compliance. This enables elimination of paper trails that companies have to maintain for compliance with Value Added Tax (VAT) laws, including complying with all the audit requirements for tax purposes.

The Sterling e-Invoicing uses the e-signature method of compliance. This is the digital signature approach in which the invoices are digitally signed by the seller, using the keys approved by the government of that country, and then the signature is verified by the buyer. Future audits can be verified for their authenticity and integrity by reverifying the signatures in the archived invoices. The e-signature method of compliance is the preferred option of the tax authorities. It is a technical solution that provides an unequivocal technical guarantee of the authenticity and integrity of the invoice. The Sterling e-Invoicing provides the following:

- A supplier process that supports invoice validation and signing.
- A buyer process that supports signature verification and invoice validation.
- An archive of the invoice functions that enable a customer or a tax auditor to search, view, and report on invoices and also to reverify the signature on those invoices in the event of an audit.
- Timestamping facility for archived invoices having country code; for example, 'IT' (Italy), is used in the audit trail of an invoice.
- Mapping functionality that enables you to translate the invoice from any supported EDI format to the canonical invoice format.

Sterling Commerce has partnered with TrustWeaver to provide e-signature signing and verification through its on-demand service. TrustWeaver offers products and on-demand services that support all of the necessary hardware and certificate authorities.

Tracking and Searching Capabilities

Sterling Integrator provides several features to help you monitor operations, track the state of data in your processes, and search for the specific information you require. For information about monitoring business processes, see the *Monitoring Business Process Operations* topic. The following table describes the tracking and searching features:

Feature	Description
Business Process Monitor	<p>This page displays a list of the 10 active or most recent processes that have run. The page refreshes automatically and shows the status of the processes. From this list, you can access detailed, step-by-step information about process activity.</p>
System logs	<p>Sterling Integrator generates log files. Currently, transaction data is collected for the operation servers and the J2EE environment.</p> <p>Each operations server on a host has its own operations log file in the appropriate directory.</p> <p>You can view the current log file's contents through portlets in the Sterling Integrator interface. You can view older, stored log files in your directory by opening them in a text editor application.</p>
Reports	<p>The Reports feature allows you to supply different parameters to the report engine in order to organize your data and produce a report that is configured in a manner that is meaningful to you.</p> <p>The Reports feature enables you to schedule the reports to be generated automatically, and automatically e-mail a report to a designated recipient.</p> <p>The Reports feature also offers preconfigured reports that you can run as is or copy and edit to suit your requirements.</p>

Feature	Description
Interface search capabilities	<p>The Sterling Integrator interface supports a variety of simple and advanced searches. For example, you can perform a simple search to locate a business process by name, or an advanced search for a business process by specifying multiple criteria, including name, date, start time, and so on.</p> <p>You can search for nearly any entity related to your use of the system, from system processes to sets of data used to regulate or enable processes. For example, you can search for:</p> <ul style="list-style-type: none"> • Active, archived, and restored business processes. • Trading partner profiles and related data such as identities, transport, and packaging information, contracts and code lists; processing or processed documents; service activity information and service configurations; transaction information; maps, user accounts, and so on. <p>Sterling Integrator does not allow you to search business processes that are both expired and purged.</p>
Event Viewer	<p>Sterling Integrator does not allow you to search business processes that are both expired and purged.</p>
Tracking features	<p>Portlets that you can display in the Community Management Dashboard enable you to track:</p> <ul style="list-style-type: none"> • Document processing (current progress, and processing over a specified time period). • Queue priority statistics, which is a graph showing the average wait time for each queue, by queue priority. • The status of trading partners in your sponsored communities. • Events as they appear (see previous description pertaining to the Event Viewer feature). • Database access activity and database usage.

Online User Documentation

Sterling Integrator

User documentation for Sterling Integrator is provided online in the documentation library. The documentation library is designed to provide easy and convenient access to information. You can browse the topics or search for specific information, bookmark favorite topics, print the documentation by topic or book, and access PDF format documents for download or printing.

Access to the documentation library is provided through links in the Sterling Integrator interface and the Sterling Commerce Support On Demand Web site.

A CD-ROM copy of the user documentation is available on request through Support On Demand.

Chapter 6. Implementation Overview

Implementation Overview

This section provides a sequential overview of the process to be followed in order to implement Sterling Integrator. The information is designed to familiarize you with the general tasks for most users.

In order to use Sterling Integrator you must complete a series of steps. The following table provides the process for implementing Sterling Integrator:

Stage	Description
1	Create architectural design plan.
2	Determine system and hardware requirements.
3	Obtain product training.
4	Network deployment planning.
5	Install Sterling Integrator.
6	Tune Sterling Integrator.
7	Configure permissions and set up user accounts.
8	Configure services and adapters.
9	Create or migrate translation maps.
10	Create business process models.
11	Schedule the business process models.
12	Associate communication adapters with business processes.
13	Create trading partner profiles.
14	Test business processes.
15	Schedule archiving and purging.

Implementation Process

The topics in this section describe the implementation stages for Sterling Integrator, and are presented in a logical order.

The descriptions of the implementation stages do not indicate the role of the user performing the tasks, but assumes that the appropriate user is performing each of the steps in the process. The user may be a system administrator or any other user having the responsibility for the described tasks.

Creating Architectural Design Plan

Your architectural design plan details the ways you will use Sterling Integrator, and the components and features you will employ in the process. This stage is perhaps the most intensive part of your overall implementation. The more accurate and detailed your plans are, the more efficiently your implementation will progress.

Your plan must center on determining the processes that your business must automate and integrate. These processes must include high-level considerations, such as plans to:

- Create peer-to-peer federated systems
- Set up clusters or use multiple nodes
- Perform internodal document tracking
- Create trading partner communities
- Use the perimeter service and other components in the DMZ

The planning process becomes complex as you study it from a software perspective and consider how you want to achieve the objectives.

For each process, Sterling Commerce professionals can help you to define the business process model you will create in Sterling Integrator, including the services, adapters, components, and technologies you require, the systems that Sterling Integrator will interact with, and provide information about what exactly has to happen to the data at each step in a process. All these factors determine your system size.

Determining System and Hardware Requirements

Before you start installing, ensure that your operating system and hardware meet the published system requirements, and any requirements specific to your customized implementation.

To approximate your system requirements, determine the processes, components, and transaction volume required for your implementation. Sterling Commerce personnel are available to assist you in this effort.

For information about the minimum requirements, see the Sterling Integrator *System Requirements* document.

Size Requirements

System size is the volume of activity your system can support. The size is computed based on processing speed, RAM (random access memory), CPUs (central processing units), and amount of free disk space available.

When planning your implementation, remember that although the published minimum size requirements support the Sterling Integrator application, they may not support for any increase in capability required by the particulars of your implementation, such as the number of transactions processed and the amount of data transferred.

Your implementation may include one or more test environments in addition to the production environment. Running a test environment is recommended because Sterling Integrator enables you to bundle the work from the test environment and migrate it to the production environment when you are ready.

Obtaining Product Training

Sterling Commerce consultants will install Sterling Integrator for you, along with a Jump Start Package for your convenience. The Jump Start package provides a preconfigured simple inbound and outbound flow, including trading profiles, enveloping activities, simple mapping for a purchase order and invoice, and so on.

The Jump Start package is designed to familiarize you with the way in which Sterling Integrator functions and to experiment with it—the first step in training. You can also use the business process models and preconfigured data from the Jump Start Package as the starting point for your implementation after modifying them to match your requirements.

After you have familiarized yourself with the Sterling Integrator interface through the Jump Start Package, you can attend the formal Sterling Integrator training.

Formal training provides detailed instructions for configuring and interacting with Sterling Integrator. Training is provided in classrooms at select Sterling Commerce locations, but can also be provided on site at your company. Contact your Sterling Commerce sales representative for details.

Network Deployment Planning

Before deploying Sterling Integrator, you must evaluate the different deployment options and determine which one best fits your budget, current infrastructure, and provides the most secure environment for your data.

Because Sterling Integrator handles critical and sensitive data, it should be deployed in a secure zone behind a firewall within your network. A firewall is a blockade between a secure internal network and an untrusted network such as the Internet. You can also use a firewall to secure one internal network from another on an intranet. If you do not deploy Sterling Integrator behind a firewall, you will be exposing your system to unwanted and possibly undetected attacks by unauthorized users.

Depending on your industry, there may be regulatory compliances that require Sterling Integrator to NOT be deployed in a non secure zone (forward zone of a demilitarized zone) of a network.

When you use a firewall as your gateway to the Internet (or other network), you reduce the risk to your internal network considerably. This enables safe, secure e-business by controlling all communications to and from the Internet.

See the Perimeter Server and Security topics in the documentation library for more information on Sterling Integrator deployment options.

Installing Sterling Integrator

Sterling Integrator can be installed either by members of Sterling Commerce Consulting Services, or your system administrator.

DMZ Considerations

You can install Sterling Integrator so that different components are installed on different machines.

The processing engine (Business Process Engine) must be installed in your most secure local-area network (LAN) in order to efficiently process your mission critical data.

However, you can install some components in your DMZ (demilitarized zone), which is a computer or small subnetwork that operates between a trusted internal network, such as a corporate private LAN, and an untrusted external network, such as the public Internet). Typically, a DMZ contains devices accessible to

Internet traffic, such as Web (HTTP) servers, FTP servers, SMTP (e-mail) servers, and DNS servers, as well as a perimeter server for security.

Sterling Integrator components installed in the DMZ are typically communication adapters that act as HTTP servlets interfacing with the Business Process Engine inside your LAN. Communication channels are opened only from the secure LAN to the DMZ, and all the data traveling through the DMZ is encrypted.

Any or all of the Sterling Integrator components can also reside on the same computer, if your network does not have a DMZ.

Tuning Sterling Integrator

Performance tuning enables you to configure Sterling Integrator to get the most efficient performance matching your specific requirements. After installation, tune Sterling Integrator—change the database settings, memory allocations, and other settings—so that it performs the way you want it to. You have the option to allocate either more or less system memory or cache for specific components, and database pools.

A wizard type interface guides you through the Performance Tuning pages of the Sterling Integrator application. The system suggests property settings based on your operating system; you can let Sterling Integrator automatically perform make settings, or, you can manually enter other settings. Whenever, you add volume or hardware to your system, review your performance tuning settings. For more information, see the *Performance Tuning Guide*.

Configuring Permissions and Creating User Accounts

Role-based security enables you to assign permissions to users or groups of users based on the tasks for which they must use Sterling Integrator. Carefully consider the users who will access the system, and create the appropriate user groups with the related permissions for the users, and then create the user accounts for the users to access Sterling Integrator.

Menu options for system components to which users do not have permission are not displayed for the corresponding users in the interface.

Configuring Services and Adapters

When you create your architectural design plan, you plan the structure of each of your business process models, and note the services required to execute each process. Configuration of services and adapters makes them available in the Graphical Process Modeler for you to include them in your business process models.

You can configure your services (including adapters) in the interface, where a setup wizard allows you to select the corresponding service, and guides you through the settings. The settings dictate the specifics of the activities to be performed by the services, such as files in which to place extracted data, required IP addresses or ports, and time-out values.

If you need to develop custom services for any of your business process models, see your sales representative about purchasing MESA Developer Studio SDK. For more information, see the *MESA Developer Studio Guide*.

Creating and Migrating Translation Maps

Translation maps specify the proper transformation of data at a particular point in a process.

When creating your business process models, you associate translation services with the appropriate translation maps you have created for that step in the process.

Use the Map Editor to create any translation maps that you have to include in your processes, and check them in.

Checking Documents In and Out of Sterling Integrator

Sterling Integrator treats process models, maps, and Web templates (created with Web Extensions) as business documents, for which it has a version control system. In order to use these documents, you must check them into and out of the system. When a document is checked out, the system locks it so that other users cannot modify it at the same time. When you check in a document, it is stamped it with a version number.

You can use a previous version for editing, activating or replacing more recent versions at any time.

Importing Translation Maps from Gentran:Server

If you are moving from Gentran:Server to Sterling Integrator, you can import existing translation maps, and then modify the database references in the maps to match the Sterling Integrator database.

Creating Business Process Models

Your architectural design plan includes details describing the business process models you must create to instruct Sterling Integrator regarding the specifics of your processes.

You can also modify the predefined business process models (including any sample business process models) instead of creating new models independently.

After creating the business process models, check them in to Sterling Integrator through the interface. To create business process models, use the Graphical Process Modeler (GPM). For information about the GPM, see the *Graphical Process Modeler* topic.

Scheduling the Business Process Models

You must create schedules for any business process models that you want the Business Process Engine to initiate at specific intervals, dates, or times.

Using the scheduling tools in the Sterling Integrator, you can configure periodic intervals or a regular time of the day or week for the Business Process Engine to run a business process, and schedule a business process to run at system startup.

Wizard screens enable you to select the business process model you want to schedule and guide you through the steps.

Associating Communication Adapters with Business Processes

After your business process models are created and checked in, you must associate any communication adapters that will be used to accept unsolicited communication with the business process models that include them. These adapters have a field among their configuration parameters to select the business process.

Creating Trading Partner Profiles

Trading profiles are collections of records that describe the technology and business capabilities of your business partners to engage in e-business with each other. Sterling Integrator uses the trading profile data to link your trading partners with the business process models you create to handle that partner's documents.

While you can create trading partner profiles at any time, they are usually created after you have defined a business process or translation map. Trading profiles referenced in EDI transactions require envelope information, which you will have after creating the map.

Within the Sterling Integrator interface, you can access Basic and Advanced options for creating your trading profiles. The process involves multiple steps as you enter information related to identification, transport and exchange of documents, delivery channel, packaging, and more. Security information that is unique to a partner is also stored here, such as digital certificate identification.

Testing the Business Processes

As a test, run the business processes you have created. You can start them manually or schedule a run time and test whether the scheduled start works in conjunction with the rest of a process.

Monitor the processes to ensure that they run properly, and make modifications, if necessary.

Scheduling Archiving and Purging

In the same manner that you schedule the business processes you have created, you can schedule the intervals at which you want to archive and purge the contents of the database. Predefined business processes manage the archiving and purging activities.

Notices

This information was developed for products and services offered in the U.S.A.

IBM® may not offer the products, services, or features discussed in this document in other countries. Consult your local IBM representative for information on the products and services currently available in your area. Any reference to an IBM product, program, or service is not intended to state or imply that only that IBM product, program, or service may be used. Any functionally equivalent product, program, or service that does not infringe any IBM intellectual property right may be used instead. However, it is the user's responsibility to evaluate and verify the operation of any non-IBM product, program, or service.

IBM may have patents or pending patent applications covering subject matter described in this document. The furnishing of this document does not grant you any license to these patents. You can send license inquiries, in writing, to:

IBM Director of Licensing

IBM Corporation

North Castle Drive

Armonk, NY 10504-1785

U.S.A.

For license inquiries regarding double-byte character set (DBCS) information, contact the IBM Intellectual Property Department in your country or send inquiries, in writing, to:

Intellectual Property Licensing

Legal and Intellectual Property Law

IBM Japan Ltd.

19-21, Nihonbashi-Hakozakicho, Chuo-ku

Tokyo 103-8510, Japan

The following paragraph does not apply to the United Kingdom or any other country where such provisions are inconsistent with local law:

INTERNATIONAL BUSINESS MACHINES CORPORATION PROVIDES THIS PUBLICATION "AS IS" WITHOUT WARRANTY OF ANY KIND, EITHER EXPRESS OR IMPLIED, INCLUDING, BUT NOT LIMITED TO, THE IMPLIED WARRANTIES OF NON-INFRINGEMENT, MERCHANTABILITY OR FITNESS FOR A PARTICULAR PURPOSE. Some states do not allow disclaimer of express or implied warranties in certain transactions, therefore, this statement may not apply to you.

This information could include technical inaccuracies or typographical errors. Changes are periodically made to the information herein; these changes will be

incorporated in new editions of the publication. IBM may make improvements and/or changes in the product(s) and/or the program(s) described in this publication at any time without notice.

Any references in this information to non-IBM Web sites are provided for convenience only and do not in any manner serve as an endorsement of those Web sites. The materials at those Web sites are not part of the materials for this IBM product and use of those Web sites is at your own risk.

IBM may use or distribute any of the information you supply in any way it believes appropriate without incurring any obligation to you.

Licensees of this program who wish to have information about it for the purpose of enabling: (i) the exchange of information between independently created programs and other programs (including this one) and (ii) the mutual use of the information which has been exchanged, should contact:

IBM Corporation

J46A/G4

555 Bailey Avenue

San Jose, CA 95141-1003

U.S.A.

Such information may be available, subject to appropriate terms and conditions, including in some cases, payment of a fee.

The licensed program described in this document and all licensed material available for it are provided by IBM under terms of the IBM Customer Agreement, IBM International Program License Agreement or any equivalent agreement between us.

Any performance data contained herein was determined in a controlled environment. Therefore, the results obtained in other operating environments may vary significantly. Some measurements may have been made on development-level systems and there is no guarantee that these measurements will be the same on generally available systems. Furthermore, some measurements may have been estimated through extrapolation. Actual results may vary. Users of this document should verify the applicable data for their specific environment.

Information concerning non-IBM products was obtained from the suppliers of those products, their published announcements or other publicly available sources. IBM has not tested those products and cannot confirm the accuracy of performance, compatibility or any other claims related to non-IBM products. Questions on the capabilities of non-IBM products should be addressed to the suppliers of those products.

All statements regarding IBM's future direction or intent are subject to change or withdrawal without notice, and represent goals and objectives only.

All IBM prices shown are IBM's suggested retail prices, are current and are subject to change without notice. Dealer prices may vary.

This information is for planning purposes only. The information herein is subject to change before the products described become available.

This information contains examples of data and reports used in daily business operations. To illustrate them as completely as possible, the examples include the names of individuals, companies, brands, and products. All of these names are fictitious and any similarity to the names and addresses used by an actual business enterprise is entirely coincidental.

COPYRIGHT LICENSE:

This information contains sample application programs in source language, which illustrate programming techniques on various operating platforms. You may copy, modify, and distribute these sample programs in any form without payment to IBM, for the purposes of developing, using, marketing or distributing application programs conforming to the application programming interface for the operating platform for which the sample programs are written. These examples have not been thoroughly tested under all conditions. IBM, therefore, cannot guarantee or imply reliability, serviceability, or function of these programs. The sample programs are provided "AS IS", without warranty of any kind. IBM shall not be liable for any damages arising out of your use of the sample programs.

Each copy or any portion of these sample programs or any derivative work, must include a copyright notice as follows:

© IBM 2015. Portions of this code are derived from IBM Corp. Sample Programs. © Copyright IBM Corp. 2015.

If you are viewing this information softcopy, the photographs and color illustrations may not appear.

Trademarks

IBM, the IBM logo, and [ibm.com](http://www.ibm.com)[®] are trademarks or registered trademarks of International Business Machines Corp., registered in many jurisdictions worldwide. Other product and service names might be trademarks of IBM or other companies. A current list of IBM trademarks is available on the Web at "Copyright and trademark information" at <http://www.ibm.com/legal/copytrade.shtml>.

Adobe, the Adobe logo, PostScript, and the PostScript logo are either registered trademarks or trademarks of Adobe Systems Incorporated in the United States, and/or other countries.

IT Infrastructure Library is a registered trademark of the Central Computer and Telecommunications Agency which is now part of the Office of Government Commerce.

Intel, Intel logo, Intel Inside, Intel Inside logo, Intel Centrino, Intel Centrino logo, Celeron, Intel Xeon, Intel SpeedStep, Itanium, and Pentium are trademarks or registered trademarks of Intel Corporation or its subsidiaries in the United States and other countries.

Linux is a registered trademark of Linus Torvalds in the United States, other countries, or both.

Microsoft, Windows, Windows NT, and the Windows logo are trademarks of Microsoft Corporation in the United States, other countries, or both.

ITIL is a registered trademark, and a registered community trademark of the Office of Government Commerce, and is registered in the U.S. Patent and Trademark Office.

UNIX is a registered trademark of The Open Group in the United States and other countries.

Java™ and all Java-based trademarks and logos are trademarks or registered trademarks of Oracle and/or its affiliates.

Cell Broadband Engine is a trademark of Sony Computer Entertainment, Inc. in the United States, other countries, or both and is used under license therefrom.

Linear Tape-Open, LTO, the LTO Logo, Ultrium and the Ultrium Logo are trademarks of HP, IBM Corp. and Quantum in the U.S. and other countries.

Connect Control Center®, Connect:Direct®, Connect:Enterprise®, Gentran®, Gentran®:Basic®, Gentran:Control®, Gentran:Director®, Gentran:Plus®, Gentran:Realtime®, Gentran:Server®, Gentran:Viewpoint®, Sterling Commerce™, Sterling Information Broker®, and Sterling Integrator® are trademarks or registered trademarks of Sterling Commerce®, Inc., an IBM Company.

Other company, product, and service names may be trademarks or service marks of others.



Product Number:

Printed in USA