



IMS Version 12

IMS to IMS TCP/IP Connectivity

Information Management software



IMS to IMS TCP/IP Connectivity

- Enhancements to leverage TCP/IP networks for communications between IMS systems for:
 - OTMA Support for Asynchronous IMS-IMS Communications
 - Uses one-way message communications (ALTPCB)

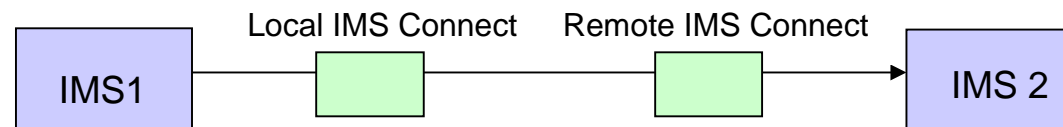

- TCP/IP-Type Physical Links (MSC)
 - Request and response message communications
 - IMS Connect processes both the request and response messages as one-way asynchronous messages

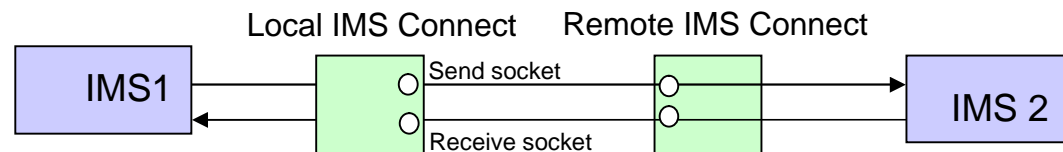

OTMA Support for Asynchronous IMS to IMS Communications

Asynchronous IMS-IMS TCP/IP Support

- TCP/IP connections between the local and remote IMS systems
 - Are managed by IMS Connect to IMS Connect communications
 - Without having to write client code or invoke additional gateways
 - The goal is simplification and ease of use

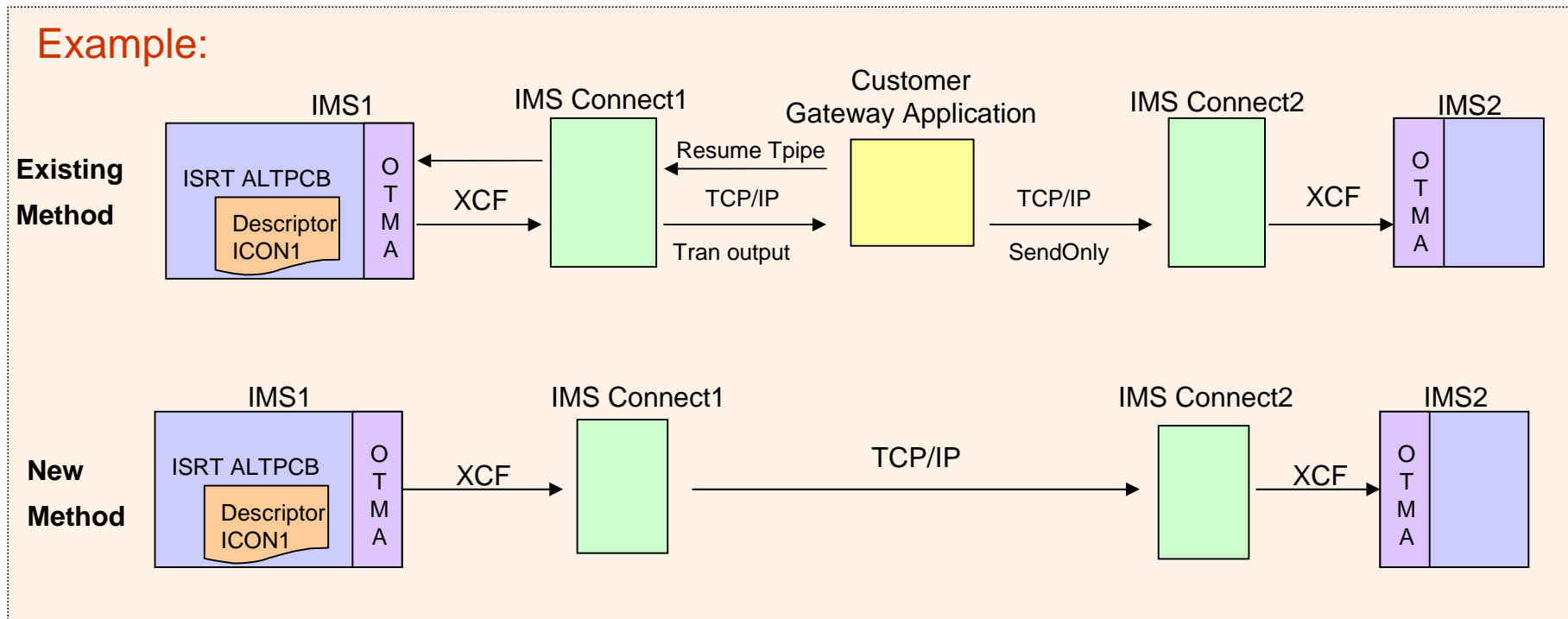

Asynchronous IMS-IMS TCP/IP Support ...

■ OTMA

- Sends OTMA remote ALTPCB messages to IMS Connect using new destination information
 - OTMA destination descriptors or DFSYDRU0 exit Routine

■ IMS Connect

- Receives OTMA ALTPCB messages from a local IMS and sends them to the remote IMS Connect for processing in the remote IMS
 - Enhanced IMS Connect configuration specifications

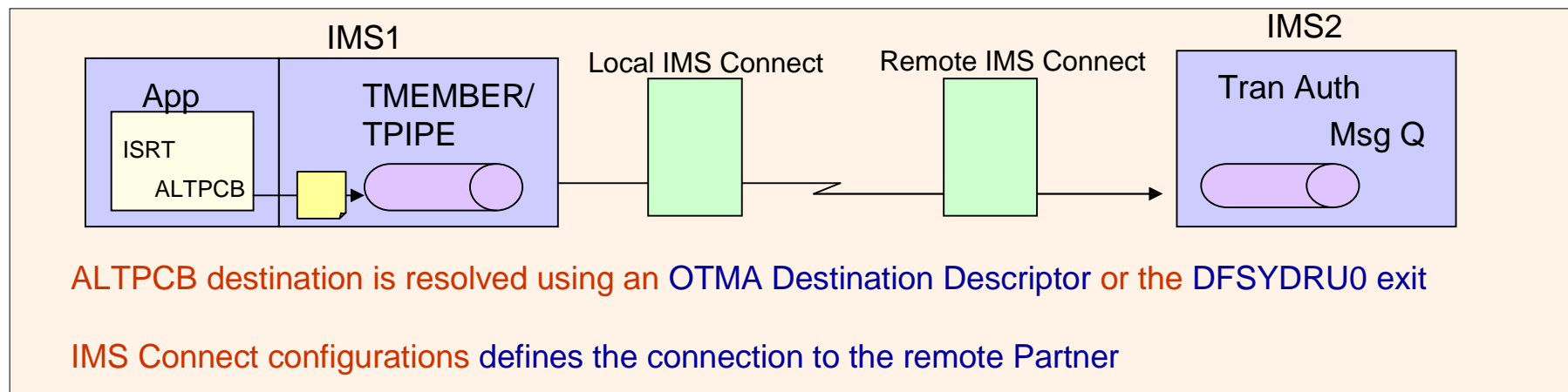

OTMA Support – DFSYDTx Descriptors and DFSYDRU0

- New **destination descriptor** parameters (DFSYDTx member of proclib)

- RMTIMSCON= specifies the remote IMS Connect (required)
- RMTIMS= specifies the target remote IMS (required)
- RMTTRAN= specifies the transaction name to use on the remote IMS (optional)
- USERID= specifies the RACF userid name to use on the remote IMS for transaction authorization (optional)

- Existing parameter (required)

- TMEMBER= specifies the local IMS Connect

OR

- **DFSYDRU0 exit**

- Set output flag bit to indicate the message is an OTMA remote ALTPCB message.
- Set the required and optional information in the OTMA prefix area (mapped by HWSOMPFX macro).
 - New specifications in the user data section:
 - OMUSR_RMTICON – remote IMS Connect
 - OMUSR_RMTIMSID – remote IMS
 - OMUSR_RMTTRAN – remote transaction
 - OMUSR_RMTUID – userid for transaction authorization

- If a descriptor is used, the DFSYDRU0 exit is not called

OTMA Support – Type-2 Commands

- Descriptors can be created, queried, or modified dynamically
 - CREATE | QUERY | UPDATE OTMADESC
 - Type-2 commands support the new parameters
 - RMTIMSCON, RMTIMS, RMTTRAN, USERID

```
CREATE OTMADESC NAME(DESC1) SET(TYPE(IMSCON) TMEMBER(ICON1) RMTIMSCON(ICON2)
RMTIMS(IMS3) RMTTRAN(TRAN01) USERID(USER01))
```

Output:

DestName	MbrName	CC
OTMACL01	IMS1	0

```
QUERY OTMADESC NAME(OTMACL01)
```

Output:

MbrName	DestName	CC	Type	TMember	SMember	Tpipe	Adapter
IMS1	DESC1	0	IMSCON	ICON1			
Converter	Option	RmtIMS	RmtIMSCon	RmtTran	Userid		
		IMS3	ICON2	TRAN01	USER01		

```
UPDATE OTMADESC NAME(DESC1) SET(RMTIMS(IMS2) RMTTRAN(TRANABC))
```

Output:

DestName	MbrName	CC
DESC1	IMS1	0

Descriptors and Command Overrides

- Specifying a descriptor parameter requires an associated value
 - Not having value can result in an error
 - Example
 - D DESC1 TYPE=IMSCON TMEMBER=ICON1 **RMTIMSCON=ICON2 RMTIMS=IMS2 RMTTRAN=**
 - DFS2385E SYNTAX ERROR FOR DESCRIPTOR = TEST0001 RMTTRAN MUST BE 1 TO 8 CHARACTERS LONG IMS1

- The Type-2 UPDATE command can specify the parameter without a value to reset it
 - Example
 - Specify the RMTTRAN parm without any value in the type-2 update command:
 - UPD OTMADESC NAME(TEST01) SET(RMTTRAN())
 - Clears the RMTTRAN field

OTMA Support – Message Flow Details

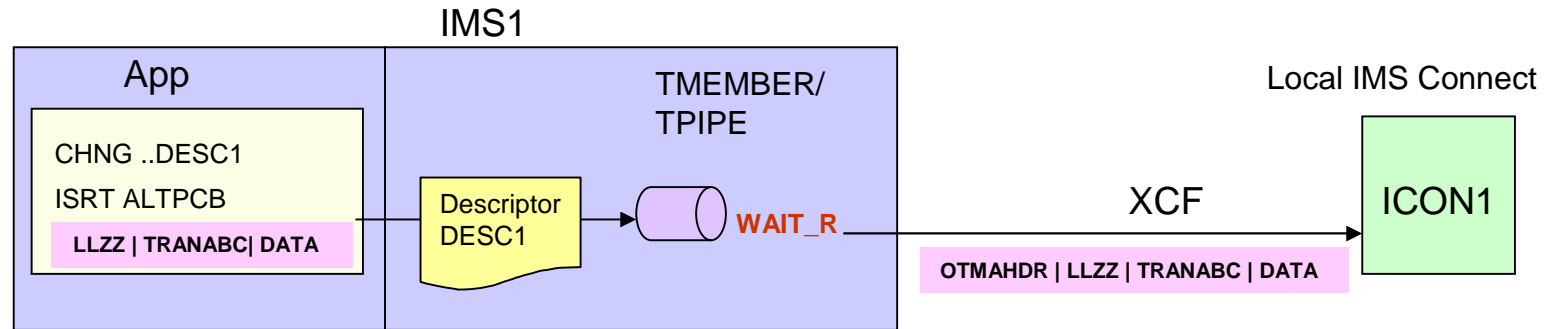

```
D DESC1 TYPE=IMSCON TMEMBER=ICON1 RMTIMSCON=ICON2 RMTIMS=IMS2
D DESC1 USERID=USER01
```

IMS Application

- Issues CHNG call to set the destination name (descriptor)
 - IMS resolves this destination using an OTMA destination descriptor by the same name or through DFSYDRU0 specifications
- Issues ISRT ALTPCB to send the message to a remote IMS

OTMA

- Using information from either the descriptor or exit
 - Sends the message to the local IMS Connect from a regular TPIPE queue
 - Builds the OTMA header
- Waits for ACK/NAK
 - TPIPE queue is in a new WAIT_R status during this wait

Note: Message Destinations

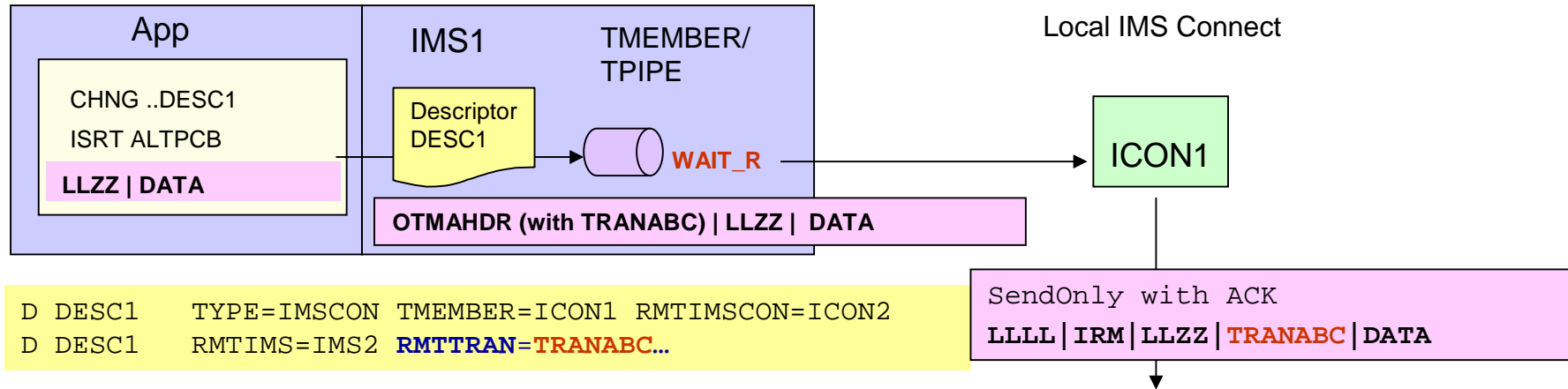

- **RMTTRAN is not specified**
 - The first 8 bytes (or first set of characters preceding a blank) in the IMS application message are considered to be the trancode
- **RMTTRAN is specified**
 - IMS Connect **always** adds the value to the message with a corresponding increase in the length of the message
 - If the application does not specify a trancode
 - IMS Connect uses the RMTTRAN value (e.g. TRANABC and increases message length)
 - Example: IMS app message: x'0010' X'0000' C'123456789012' (LLZZ|DATA)
After IMS Connect: x'0018' X'0000' C'TRANABC 123456789012'
 - If the application specifies trancode at the beginning of the message
 - The message built by IMS Connect will include both trancodes with an increase of the message length
 - Example: IMS app message: x'0010' X'0000' C'TRAN123 9012' (LLZZ|DATA)
After IMS Connect: x'0018' X'0000' C'TRANABC TRAN123 9012'
- **The remote IMS may reject the message if the trancode is invalid**
 - HWST3570E on local IMS Connect and the NAK'd message is sent to HWS\$DLQ on local OTMA

IMS Connect Support

- IMS Connect provides a new configuration statement **RMTIMSCON** to describe the remote IMS Connect TCP/IP environment

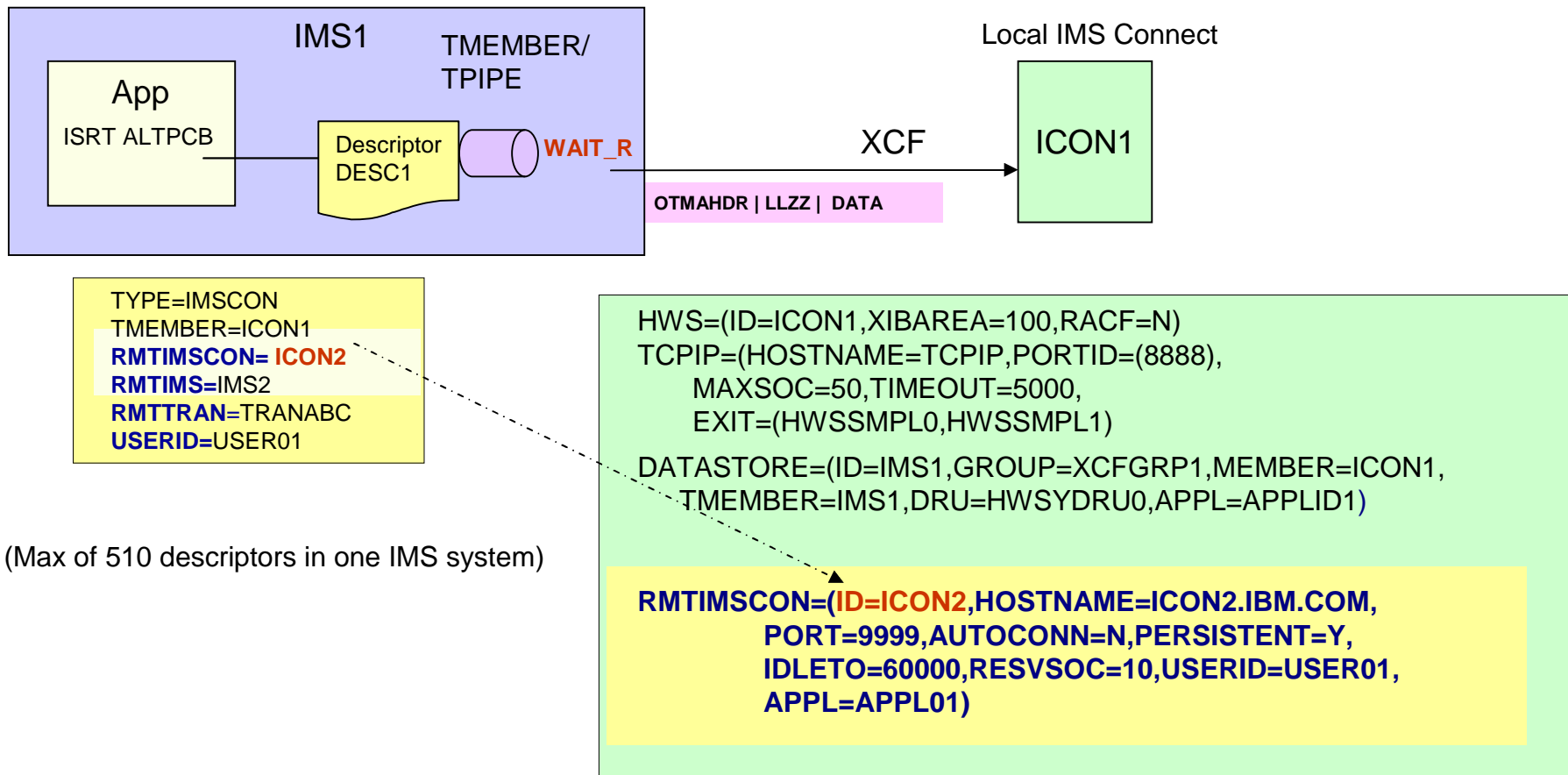

(Max of 510 descriptors in one IMS system)

IMS Connect Configuration – RMTIMSCON ...

```
RMTIMSCON=(ID=ICON2,HOSTNAME=ICON2.IBM.COM, PORT=9999,AUTOCONN=N,PERSISTENT=Y,  
IDLETO=60000,RESVSOC=10,USERID=USER01,APPL=APPL01)
```

- New RMTIMSCON statement in the local IMS Connect identifies the remote IMS Connect partner information
 - **ID=** Identifier for a remote IMS Connect connection
 - **IPADDR=** specifies the remote IMS Connect IP address (IPADDR or HOSTNAME required, but not both)
 - Accepts a loopback IP address
 - Local and remote IMS Connects are on the same TCP/IP stack (same LPAR)
 - In the range 127.0.0.0 to 127.255.255.255
 - Likely used only in test environments
 - **HOSTNAME=** specifies the remote IMS Connect hostname
 - **PORT=** specifies the remote IMS Connect port
 - **AUTOCONN=** Y|N, specifies whether to automatically make socket connections to the remote IMS Connect on startup (optional - for OTMA only, MSC requires AUTOCONN=N)
 - **PERSISTENT=** Y|N, specifies whether the socket connections to this remote IMS Connect are persistent (optional - for OTMA only, MSC requires PERSISTENT=Y)

IMS Connect Configuration - RMTIMSCON

```
RMTIMSCON=(ID=ICON2,HOSTNAME=ICON2.IBM.COM, PORT=9999,AUTOCONN=N,PERSISTENT=Y,  
IDLETO=60000,RESVSOC=10,USERID=USER01,APPL=APPL01)
```

- New RMTIMSCON statement in the local IMS Connect identifies the remote IMS Connect partner information...
 - **IDLETO=** specifies the amount of time the socket connection is idle before terminating it due to inactivity (Optional, for OTMA only)
 - **RESVSOC=** specifies the number of sockets to reserve for use to this remote IMS Connect
 - **USERID=** specifies user ID for generating RACF Passticket to be use by the remote IMS Connect for authenticating the user (optional – if specified, then APPL must also be specified.)
 - **APPL=** specifies the application name for generating RACF Passticket to be use by the remote IMS Connect for authentication
 - optional – if specified, then USERID must also be specified

Remote IMS Connect Configuration

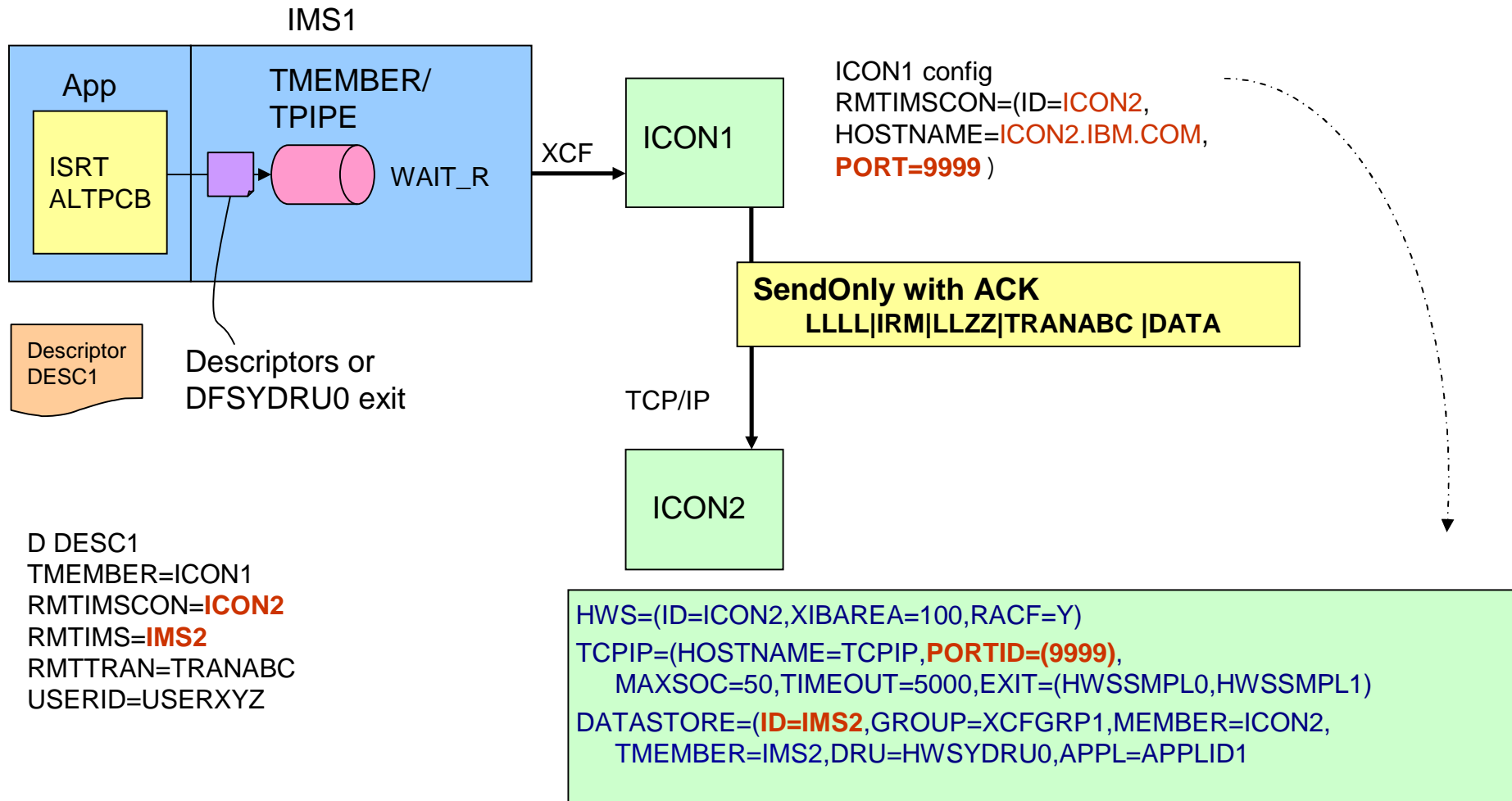

Send to remote IMS

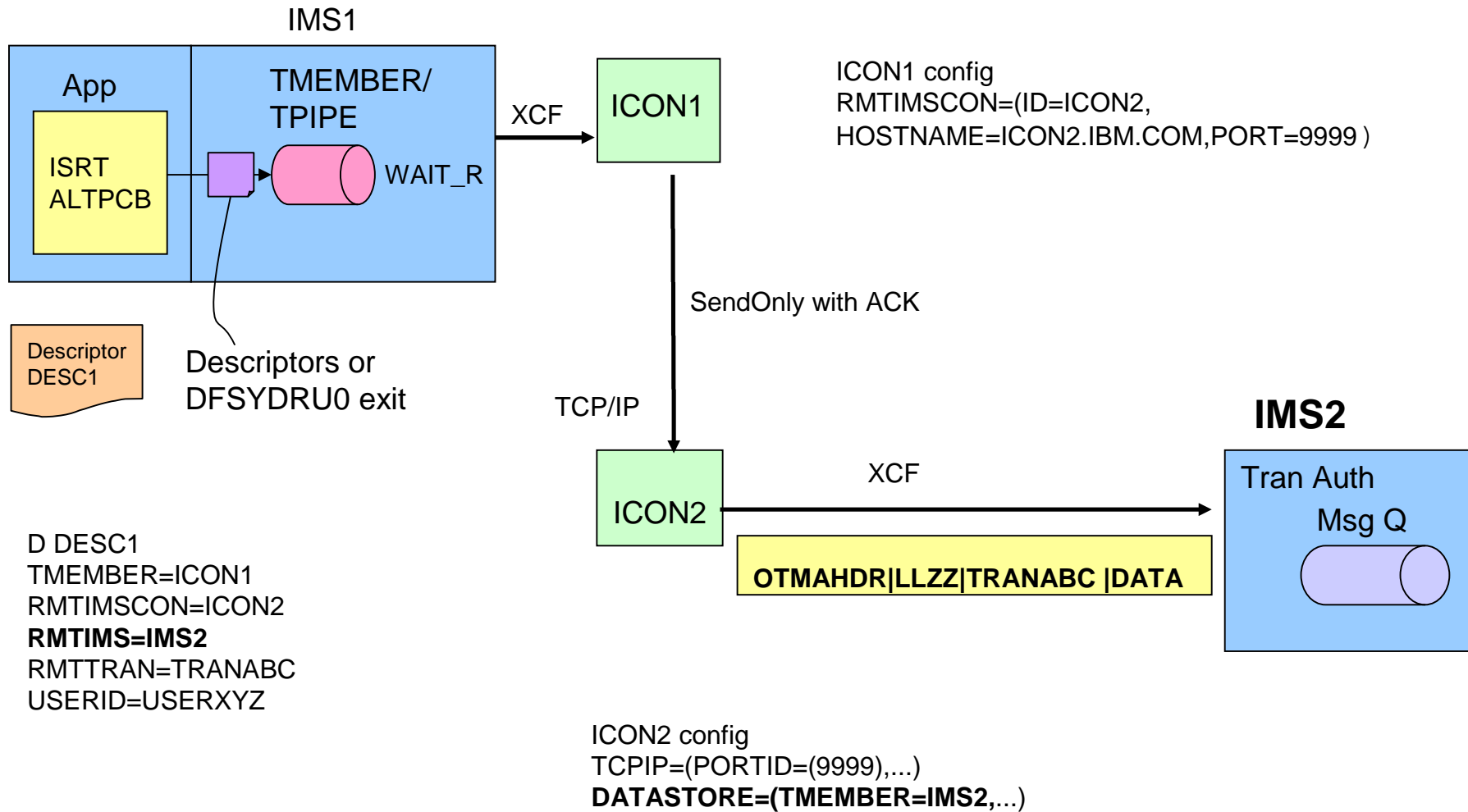

And finally ... the Return ACK / NAK

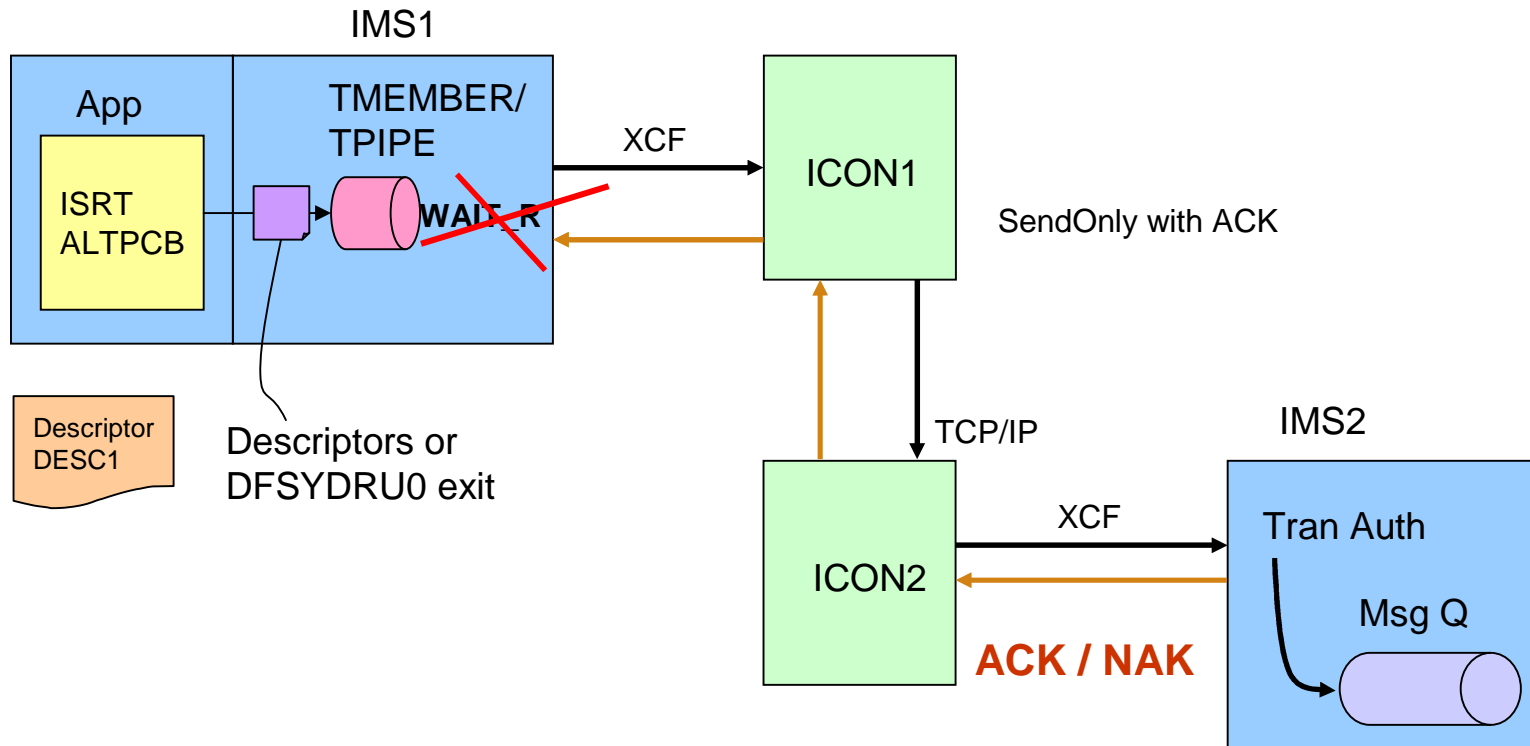

IMS2 performs transaction authorization, if necessary, and ACKs or NAKs the message

If a message is NAKed, the OTMA correlator token from the initial request is passed back so that IMS1 can match the NAK to the request

Application Considerations

- This support assumes the destination is a transaction
 - No support for messages being sent to an LTERM destination name
- On the remote IMS (e.g., IMS2)
 - IOPCB LTERMname is OTMxxxxx
 - Clientid generated by the sending IMS Connect, e.g., ICON1
 - IOPCB output is placed on the hold queue
 - Either retrieved using a Resume TPIPE request or purged via command
 - If the application issues an ALTPCB for a destination back in the other IMS (e.g., IMS1)
 - Definitions for OTMA descriptor and RMTIMSCON going from IMS2 to IMS1

Super Member support

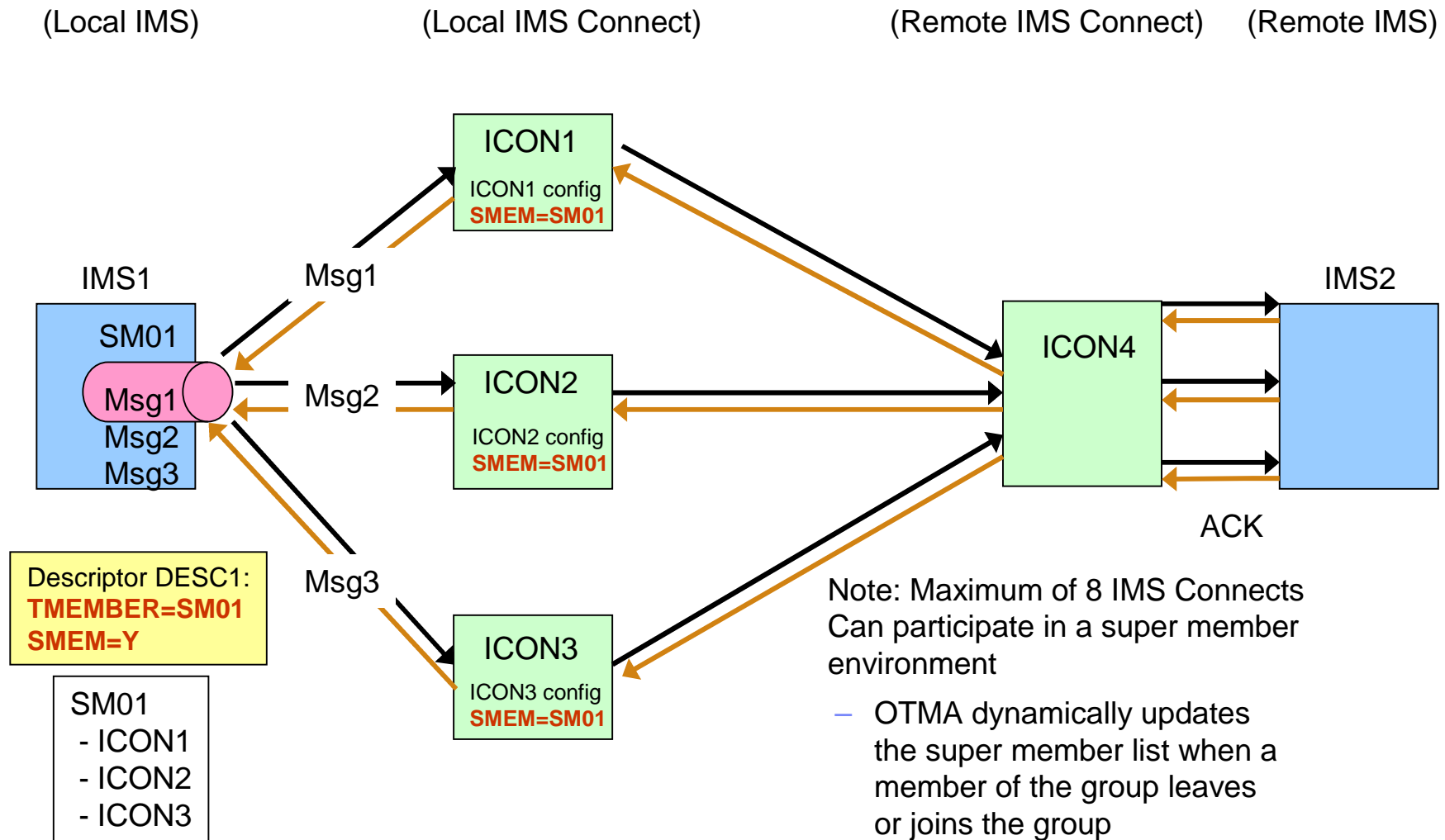

Security: Transaction Authorization

Security: Transaction authorization – Default userid

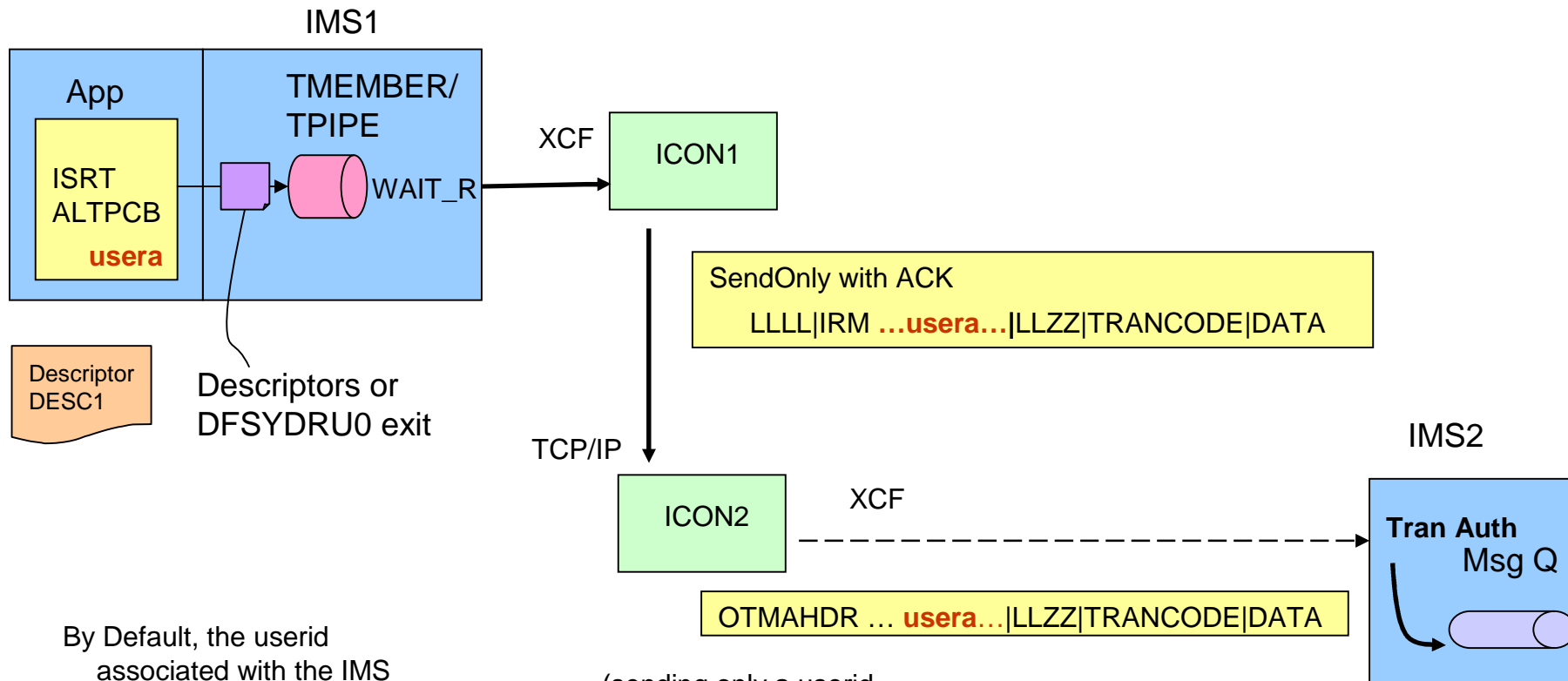

By Default, the userid associated with the IMS application issuing the ISRT call is propagated with the message to the remote IMS system

(sending only a userid with no password is applicable only if **RACF=N** in the configuration file)

On the target IMS, the userid associated with the originating IMS application is used to determine whether access to the transaction is allowed.

Security: Transaction authorization – Alternate userid

- Alternatively, the OTMA descriptor can be used to specify a userid
 - Overrides the userid associated with the sending IMS application

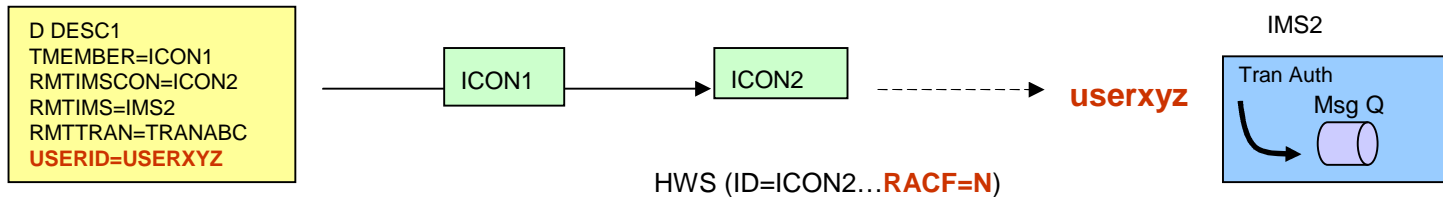

- And optionally, “connection security”
 - RMTIMSCON configuration in IMS Connect provides USERID and APPL
 - Supports generation of a PassTicket for a trusted user connection
 - Final override userid value

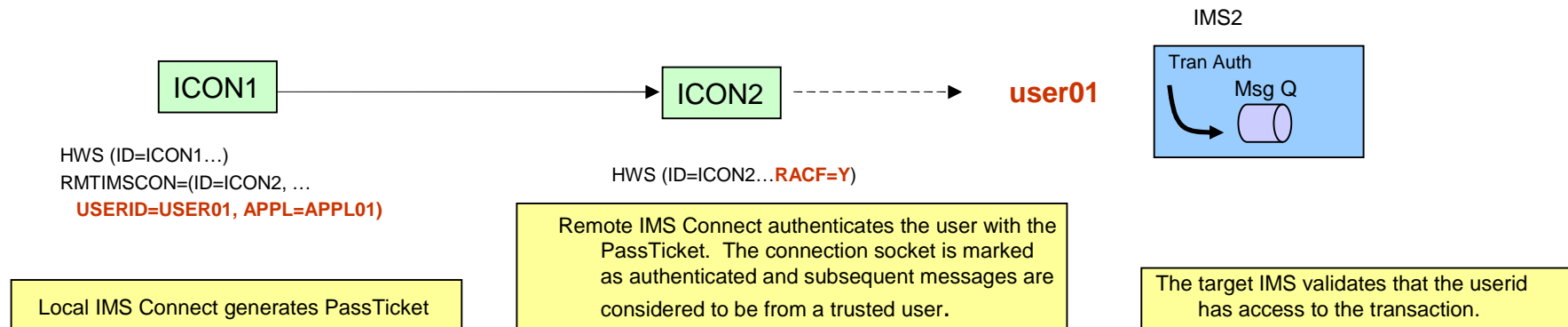

Security: Transaction authorization - Alternate userid...

- For two-way “connection security”
 - RMTIMSCON security specifications must be made on both systems

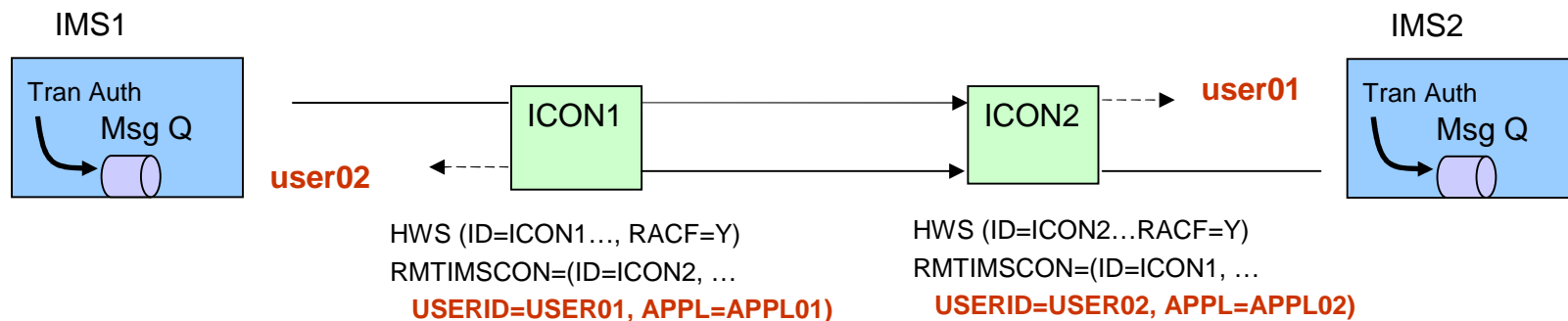

IMS Connect1 calls RACF to create a PassTicket using USERID (USER01) and APPL(APPL=01). It sends the userid and PassTicket to IMS Connect2 on the request socket.

IMS Connect2 calls RACF to authenticate the userid (USER01) using the PassTicket. The request socket is authenticated.

IMS Connect1 calls RACF to authenticate the userid (USER02) using the PassTicket. The response socket is authenticated.

IMS Connect2 calls RACF to create a Passticket using USERID (USER02) and APPL (APPL02). It sends the userid and PassTicket to IMS Connect1 on the response socket

Note: Only security that is applicable to MSC connection

PassTicket Connection Security

- **Applicable to persistent connections**
 - Setup
 - Sending (Local) Side
 - RACF: Define PTKTDATA Class entry
 - IMS Connect: Specify USERID and APPL in the RMTIMSCON definition
 - Receiving (Remote) Side
 - RACF: Define matching PTKTDATA Class entry
 - Define APPL Class entry
 - Authorize (PERMIT) valid connection userids
 - Results
 - Sending IMS Connect generates the PassTicket and sends the connection credentials
 - once per socket on first request
 - Receiving IMS Connect with RACF=Y specified authenticates and authorizes the connection
 - sets socket as trusted for subsequent transactions

Not recommended
for short-lived, non-
persistent
connections

PassTicket Connection Security - Details

■ Sending or Local IMS Connect

- RMTIMSCON statement must specify both USERID and APPL
 - If only one is specified, IMS Connect issues an error message and abend at startup

```
HWSX0909E ERROR IN PROCESSING CONFIG MEMBER HWSMSC01; M=XCFG  
HWSX0909E THE APPL IS NOT SPECIFIED BUT THE USERID IS; R=68, S=NOAPPLID  
BPE0006I HWS TRSP TCB ABEND U3401-00000004 DIAG=1004000180
```

- Create PTKTDATA Class entry in RACF

- **Key** must match remote side

```
SETROPTS CLASSACT(PTKTDATA)  
SETROPTS RACLIST(PTKTDATA)  
RDEF PTKTDATA APPLI2I SSIGNON(KEYMASKED(E001193519561977)) UACC(N)  
SETROPTS REFRESH RACLIST(PTKTDATA)
```

- IMS Connect generates Passticket from Userid and APPL
 - Only on first send, regardless of RACF= specification on the sending IMS Connect system
 - Userid does not have to exist, but PTKTDATA class resource must

PassTicket Connection Security – Details ...

- Receiving or Remote IMS Connect
 - Requires RACF specifications for the users, PTKTDATA, and APPL
 - Remember that the PTKTDATA Class entry **key** must match sending side

```

DELUSER USER001
ADDUSER USER001 PASSWORD(USER0001) TSO(ACCTNUM(D1001) PROC(TPROC02))
DELUSER USER002
ADDUSER USER002 PASSWORD(USER0002) TSO(ACCTNUM(D1001) PROC(TPROC02))

SETROPTS CLASSACT(PTKTDATA)
SETROPTS RACLIST(PTKTDATA)
RDEF PTKTDATA APPL02 SSIGNON(KEYMASKED(E001193519561977)) UACC(N)
SETROPTS REFRESH RACLIST(PTKTDATA)

SETROPTS CLASSACT(APPL)
SETROPTS RACLIST(APPL)
RDEFINE APPL APPL02 UACC(N)
PE APPL02 ACCESS(READ) CLASS(APPL) ID(USER002)
SETROPTS RACLIST(APPL) REFRESH
RLIST APPL APPL02 AU
  
```

PM32008

To prevent timeouts

```

RDEF PTKTDATA APPL02 SSIGNON(KEYMASKED(...)) UACC(N)+
APPLDATA('NO REPLAY PROTECTION')
  
```

Operational and Usage Considerations

Considerations

■ Operational Characteristics

- Each RMTIMSCON statement results in a separate TCB
- If AUTOCONN=Y and PERSISTENT=N
 - AUTOCONN is internally reset to N
 - HWSX0902W message is issued
- AUTOCONN=Y and PERSISTENT=Y connections are protected from timing out with DELDUMMY
 - For socket connection that have been established
 - Local IMS Connect sends PING message with OTMxxxxx client name to keep connection from timing out on remote IMS Connect
- After receipt of ACK/NAK on a non-persistent connection
 - Associated socket connection and control blocks are cleaned up
- Persistent sockets are closed if idle for the IDLETO timeout value

Considerations

- **Restrictions**
 - Cannot be used from IMS in a shared queues environment that is not connected to IMS Connect
 - Resolution is to establish connectivity directly from each IMS
 - Super member support only allows up to 8 IMS Connects or 8 IMS Connect datastores in a super member group

- **Wait-R can result in a NAK due to error situations**
 - Can cause message reroutes to the dead letter queue, e.g., HWS\$DLQ

Considerations ...

■ Timeouts

- When a message is sent to the remote IMS, the tpipe from which the message is sent is in WAIT_R state
 - If a timeout occurs based on CMO ACK timeout value (IMS 11)
 - OTMA reroute message to the timeout queue and issues DFS3494E

■ IMS Connect Auto Retry

- If a connection cannot be established to send a message to the remote IMS Connect
 - NAK is sent to the local OTMA to keep the message at the front of the queue
 - Connection retry occurs every 2 minutes if failure is due to
 - TCP/IP is not available (local or remote)
 - Remote IMS Connect is not available
 - When connection is established, OTMA is notified

Possible Timeout Scenarios

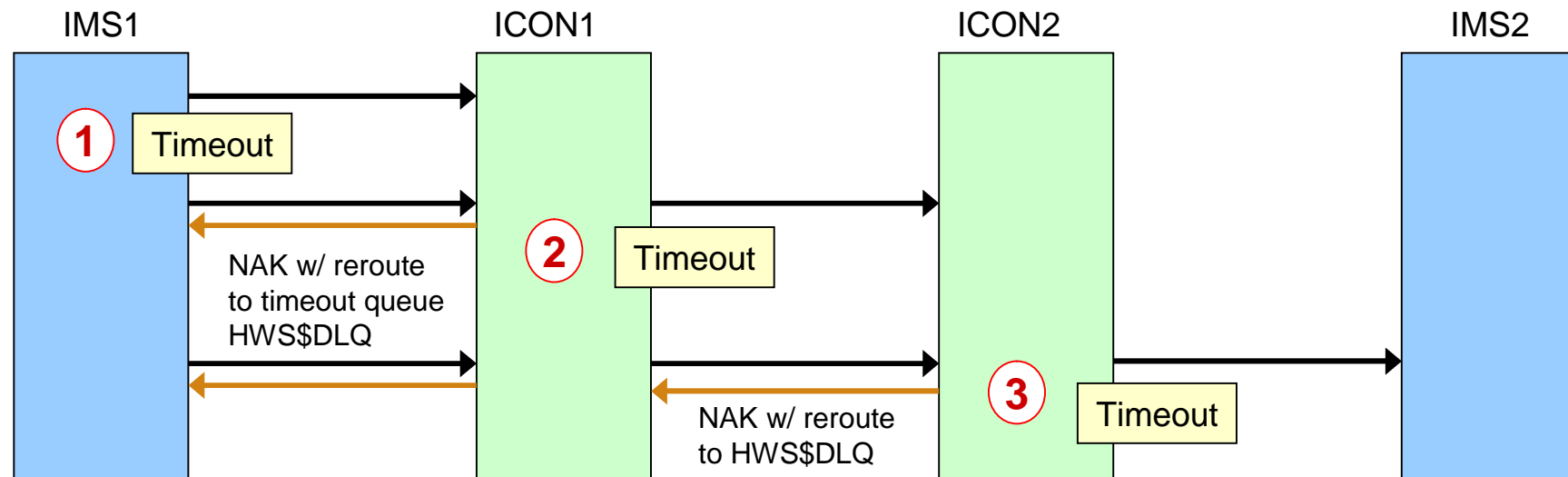

1. OTMA ACK timeout: message is moved to dead letter queue, e.g., HWS\$DLQ
2. Local IMS Connect ACK timeout: send NAK to local IMS with reroute to dead letter queue
3. Remote IMS Connect ACK timeout: send NAK to local IMS Connect and local IMS with reroute to dead letter queue

(Late Reply ACKs are NAKed by OTMA with RC=2B which is ignored by IMS Connect)

Messages on the dead letter queue can either be dequeued via command, or retrieved by issuing a Resume TPIPE request against the dead letter queue

Error Scenarios

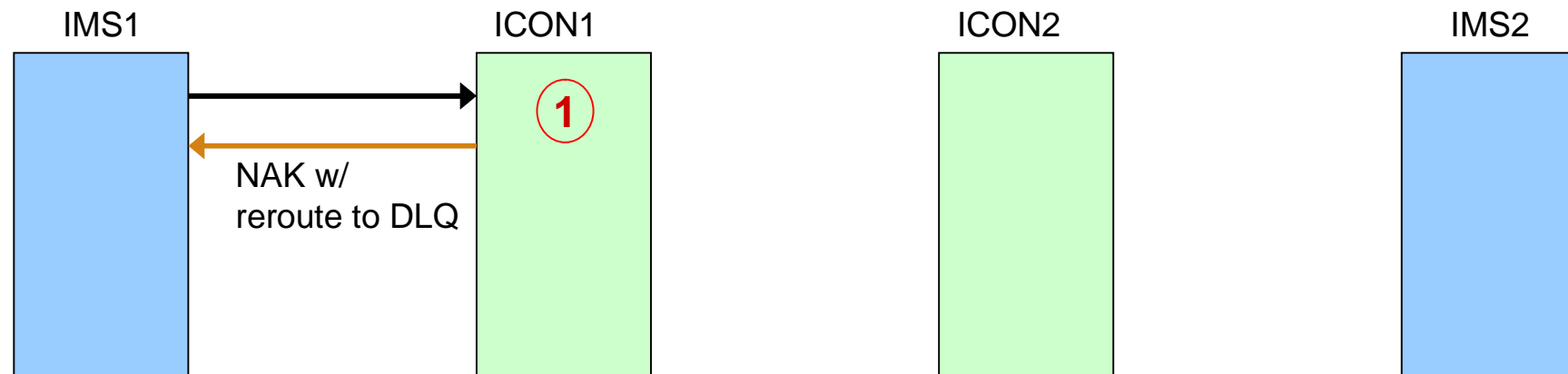

Example 1: Error in local IMS Connect , e.g., RMTIMSCON is not defined or internal error occurs.

- Local IMS Connect, NAKs with a reroute to the dead letter queue HWS\$DLQ
- OTMA creates 6701 log record with ICON's RC/RSN.
- OTMA copies IMS Connect's RC/RSN into the original rerouted message, and routes the message to HWS\$DLQ
- Local IMS Connect issues WTO error message.

Operator or Administrator action: To retrieve the message from the dead letter queue for analysis, invoke previously prepared Resume TPIPE process against the dead letter queue

Error Scenarios ...

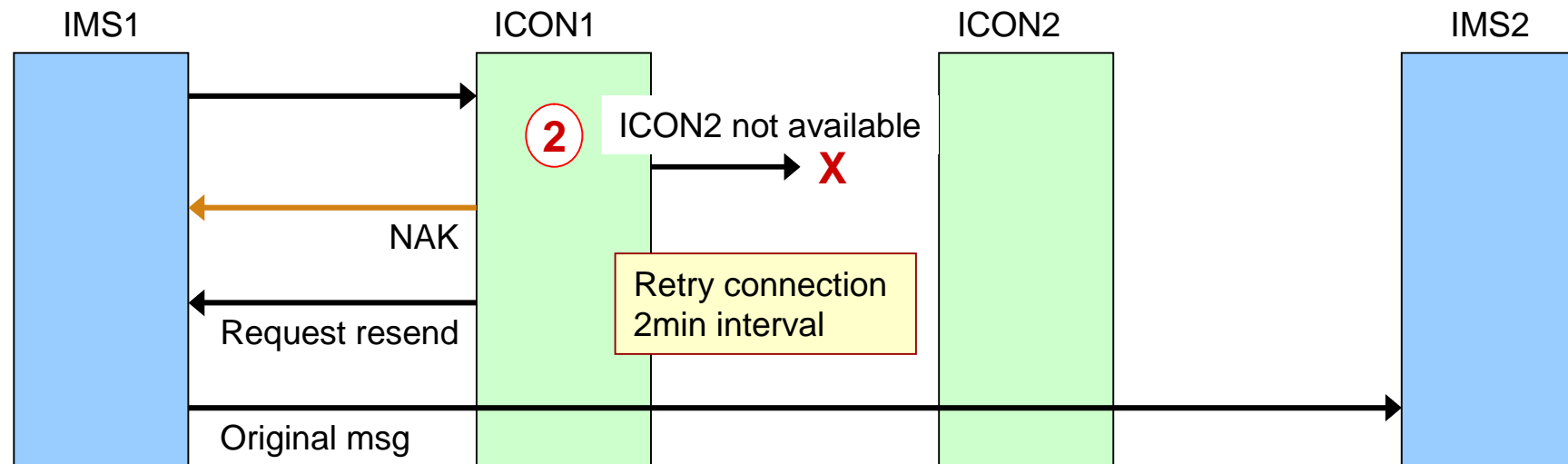

Example 2: Remote IMS Connect (ICON2) is unavailable

- Local IMS Connect sends NAK to local IMS
- OTMA leaves message in the front of the local IMS queue
- OTMA creates 6701 log record with IMS Connect's RC/RSN
- Local IMS Connect retries connection to remote ICON every 2 min.
 - > If successful, local IMS Connect sends protocol to OTMA to resend the message
 - > OTMA sends the original message to the local IMS Connect

Operator or Administrator action: None. Automatic retry and resend.

Error Scenarios ...

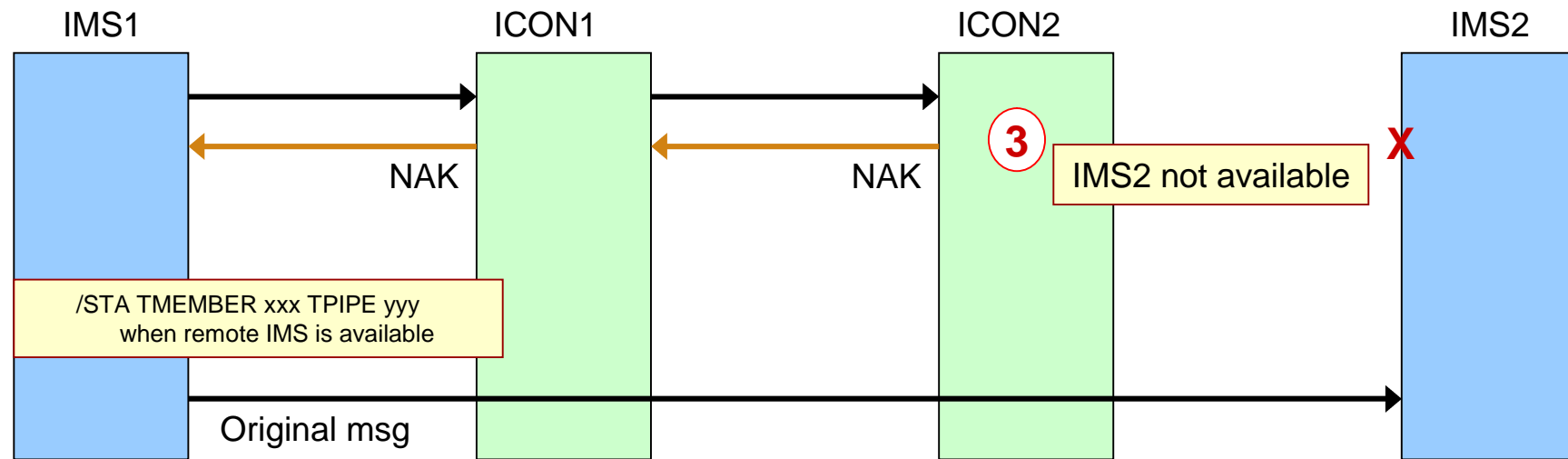

Example 3: Remote IMS is not available

- Remote IMS Connect sends NAK to the local IMS Connect which forwards on the NAK to the local IMS
- OTMA leaves the original message in front of queue.
- OTMA creates 6701 log record with IMS Connect's RC/RSN.
- Local IMS Connect issues a WTO error message.

Operator or Administrator action: When the remote IMS becomes available, issue a `/STA TMEMBER TPIPE` on the local IMS – this causes OTMA to resend the message

Considerations, Usage, and Benefits

■ Operational Characteristics

- Each RMTIMSCON statement results in a separate TCB
- Restrictions
 - Cannot be used from IMS in a shared queues environment that is not connected to IMS Connect
 - Super member support only allows up to 8 IMS Connects or 8 IMS Connect datastores in a super member group

■ Usage

- IMS applications: ISRT ALTPCB
- IMS environment: destination descriptor or a DFSYDRU0 exit routine
- IMS Connect: configuration specifications

■ Benefits

- Supports TCPIP communications to invoke transactions between IMS systems without having to create or maintain a separate gateway solution
 - IMS-provided and supported solution

MSC TCP/IP

MSC TCP/IP

- Support for MSC communications across a TCP/IP network
 - A new physical link MSPLINK TYPE=TCPIP
 - Provides a mechanism to
 - Take advantage of TCP/IP networks
 - Complement or backup existing SNA/VTAM links
 - Take advantage of potentially higher bandwidths
 - Supports operational compatibility with other link types (CTC, MTM, VTAM)
 - Starting, stopping, updating, displaying, and assigning resources
 - Only between IMS 12 systems

Highlights

- MSC TCP/IP leverages IMS Connect and the Common Service Layer
 - IMS Connect sends/receives messages via the TCP/IP network
 - IMS Connect manages the TCP/IP communications
 - IMS MSC manages the message processing
 - CSL provides the Structured Call Interface (SCI) for communications between IMS components including IMS Connect
 - Each IMS and its local MSC-routing IMS Connect system must be part of the same IMSplex
 - IMSPLEX= plexname parameter in the Common Layer Section of the DFSDFxxx of IMS proclib
 - The Operations Manager (OM) is not required but recommended
 - For type-2 command support

Highlights ...

- **IMS to IMS Connect functionality**
 - Isolates TCP/IP from the IMS Control Region
 - Uses the existing IMS Connect TCP/IP support
 - Provides a new MSC driver as well as TCP/IP driver for MSC
 - Supports communication with IMS via the Structured Call Interface (SCI)

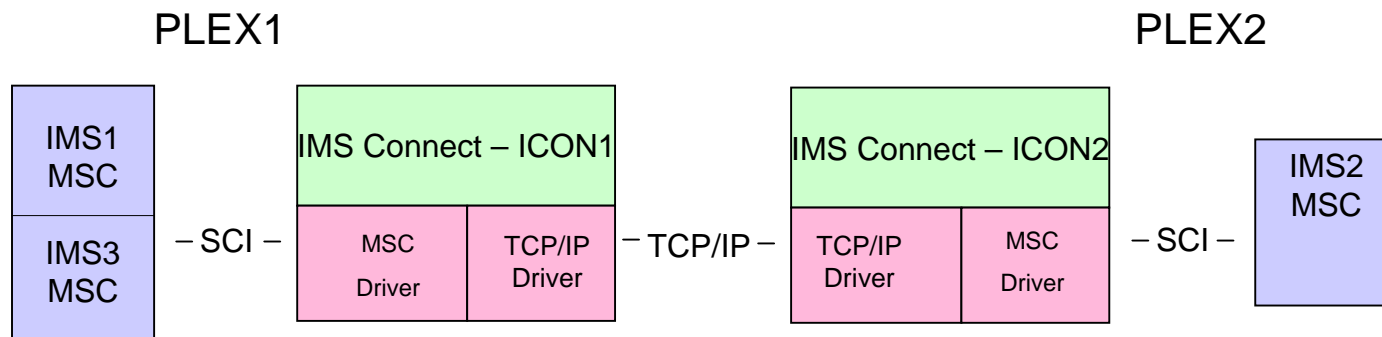

IMS Definition: MSPLINK

- MSPLINK macro defines the physical link (new parameters)

```
PLNK12TA MSPLINK TYPE=TCPIP,NAME=IMS2,LCLICON=ICON1,LCLPLKID=MSC12,  
                BUFSIZE=8192,SESSION=2
```

- **TYPE =**
 - Defines the physical link type as TCP/IP
- **NAME =**
 - IMSID of remote IMS (for VTAM links this value is APPLID)
- **LCLICON =**
 - Identifies the local IMS Connect member within the IMSplex
- **LCLPLKID =**
 - The ID of the MSC statement within the local IMS Connect configuration member
 - The associated MSC statement contains the IMS Connect configuration definitions for the physical link.

IMS Connect Configuration : MSC Statement

- New MSC statement in IMS Connect supports the MSPLINK connection

```
MSC=(LCLPLKID=MSC12,RMTPLKID=MSC21,LCLIMS=IMS1,RMTIMS=IMS2,  
      IMSPLEX=(MEMBER=ICON1,TMEMBER=PLEX1),RMTIMSCON=CONNECT2)
```

- **LCLPLKID =**
 - Identifies the name of this MSC statement for the local IMS
- **RMTPLKID =**
 - Identifies the name of the matching MSC statement in the remote IMS
- **LCLIMS =**
 - Identifies the local IMS IMSID
- **RMTIMS =**
 - Identifies the remote IMS IMSID
- **IMSPLEX =** identifies the plexname information for SCI communications
 - MEMBER= IMS Connect's name,
 - TMEMBER = the IMS plexname as also defined in DFSCGxxx
- **RMTIMSCON** (must be different than the one for async IMS-IMS support)
 - Specifies the associated remote IMS Connect identifier statement

IMS Connect Configuration: RMTIMSCON Statement

- New RMTIMSCON statement identifies the remote IMS Connect partner information

```
RMTIMSCON=(ID=CONNECT2, HOSTNAME=ICON2.IBM.COM, PORT=9999, RESVSOC=2)
```

- **ID=**
 - Identifier for a remote IMS Connect connection
 - **Different** than the one used for asynchronous IMS-IMS support
- **IPADDR=**
 - specifies the remote IMS Connect IP address (IPADDR or HOSTNAME required, but not both)
- **HOSTNAME=**
 - specifies the remote IMS Connect hostname
- **PORT=** specifies the remote IMS Connect port
- **RESVSOC=** number of sockets to reserve
 - Match with MSC parallel sessions across the link definitions
 - Coordinate with overall MAXSOC ★

Example: Configuration Definitions

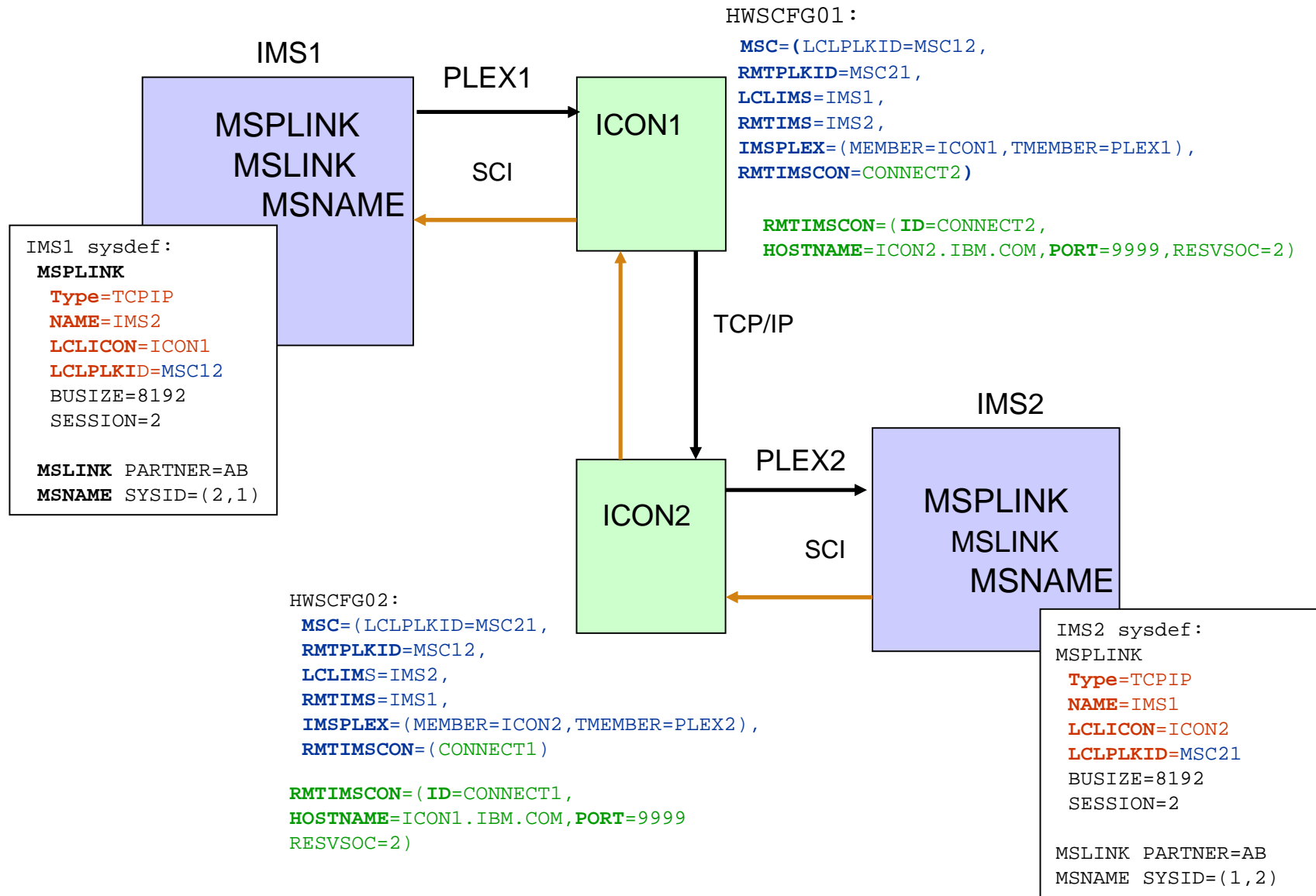

Example: 3-way IMSplex configuration

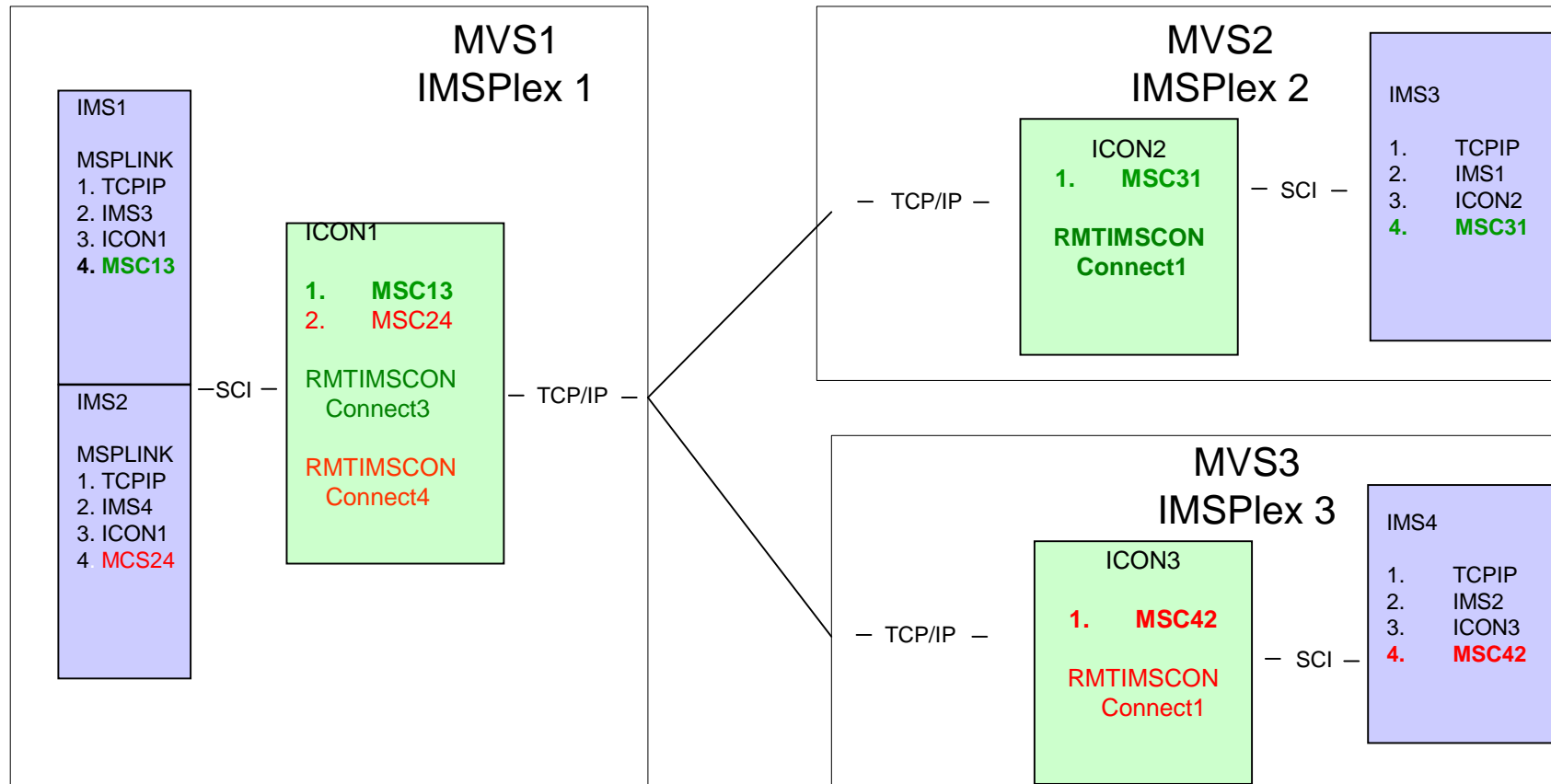

IMS Considerations

- Use of TCP/IP MSC links
 - Requires IMSplex architecture
 - SCI interface to IMS Connect
 - Relies on Type2 command support for **optimally** managing the environment
 - Operations Manager
 - Only uses bandwidth (BW) mode
 - BW mode was introduced in IMS 10 as optional for CTC, MTM, and VTAM links

- Installing at least one MSC link of any type also installs MSC
 - If MSC is defined in one IMS within a shared queues IMSplex, it must also be installed in the other IMS systems
 - No change from previous releases

Operational Considerations

■ Type-1 Commands

- /DIS ASSIGNMENT MSPLINK command
 - Displays: Type = TCPIP and Name = the remote IMSID.
- Other MSC type-1 commands, no changes (i.e. /RST link, /PSTOP link, etc)

■ Type-2 Commands

- Query MSPLINK shows all the new MSPLINK parameters
 - Type, Name, LCLICON, LCLPLKID
- Other MSC type-2 commands, no changes
- **Enhanced** IMS Connect Type-2 query and update command support
 - Documented in the IMS Connect Type-2 Commands presentation
- **New** IMS Connect WTOR command support (ViewMSC, StartMSC, etc)
 - Documented in the Reference information at the end of this section

Operational Considerations...

- Example: Type-1 Commands

```

/DIS ASMT MSPLINK ALL

Response:
LINK      PLINK          TYPE      ADDR          MAXSESS     NODE
  3      PLNK12M      MTM       ****
  2      PLNK12C      CTC       0511
  1      PLNK12V      VTAM      02000006     3           L6APPL1
  4      PLNK12TA     TCPIP     ****         2           IMS2
    
```

- Example: Type-2 Commands

```

QUERY MSPLINK TYPE(TCPIP) SHOW(ALL)

TSO SPOC output:
MSPLink  MbrName CC   Type   RmtIms  LclImsCon  LclPlkID  LclStat
PLNK31TA SYS3   0   TCPIP  IMS1     ICON3      MSC31
    
```

Type-2 command	Equivalent type-1 IMS Connect command
UPDATE MSPLINK NAME(msplinkname) SET(ICONPLKID(<i>iconplkid</i>))	No similar type-1 IMS command exists.
UPDATE MSPLINK NAME(msplinkname) SET(IMSCON(<i>imsconname</i>))	No similar type-1 IMS command exists.
UPDATE MSPLINK NAME(msplinkname) SET(RMTIMS(<i>rmtims</i>))	No similar type-1 IMS command exists.

Operational Considerations...

■ MSC TCP/IP Error Messages

- DFS3175E An MSC CSLSCMSG request failed
- DFS3176E ICON error message received
- DFS3177E MSC detected an error
- DFS3178E MSC detected an internal logic error

■ Security

- IMS and IMS Connect both register with SCI at initialization
 - Using a CSLREG request which issues a RACROUTE REQUEST=AUTH
 - The associated address space userid must have UPDATE authority
 - Note: CSL SCI Security is documented in the IMS System Administration Guide

Operational Considerations...

- **IMS shutdown or abend**
 - For *MSC connections*
 - IMS cleans up links for IMS shutdown and sends link shutdown directive to IMS Connect
 - IMS Connect disconnects the send and receive clients associated with the MSC physical links for that IMS
 - IMS Connect's MSC status is set to DISCONNECT
 - IMS Connect action for *OTMA connections*
 - For connections in CONN state
 - On IMS shutdown and abend, no action for IMS Connect
 - For connections in RECV state
 - When ACK/NAK is received
 - IMS Connect cannot deliver it so it throws the message away and issues an error message

Operational Considerations...

- **IMS shutdown or abend ...**
 - OTMA action for TPIPEs in WAIT_R state
 - On IMS shutdown
 - When IMS processes a warm restart, OTMA places messages that are in the tpipe into a timeout queue
 - On IMS abend
 - When IMS ERE restarts, OTMA places messages that are in the TPIPE into a timeout queue

- **SCI shutdown or abend**
 - IMS Connect disconnects the send and receive clients for MSC physical links that use the IMSplex
 - IMS Connect's MSC status is set to DISCONNECT
 - IMS cleans up MSC physical links.
 - IMS issues DFS3177E message.
 - MSC link state PSTOPPED IDLE ERE

Operational Considerations

- **IMS Connect shutdown or abend**
 - For MSC connections
 - IMS Connect disconnects send and receive clients for all MSC physical links
 - On shutdown, IMS Connect sends MSC level shutdown directive to MSC
 - On abend, IMS gets notified by SCI
 - IMS MSC cleans up physical link
 - Issues DFS3176E or DFS3177E message
 - For OTMA connections
 - For connections in CONN state, IMS Connect closes connections
 - For connections in RECV state
 - On IMS Connect force shutdown (CLOSEHWS FORCE), a NAK is sent to OTMA with reroute to timeout queue.
 - On IMS Connect shutdown (CLOSEHWS), IMS Connect waits for the ACK/NAK indefinitely.
 - On IMS Connect abend, OTMA reroutes messages to the timeout queue

Setup Scenario and Switching from VTAM to TCP/IP

- All IMS systems must be at V12 to use MSC TCP/IP
 - Consider a VTAM to TCP/IP migration and TCP/IP to VTAM fallback scenario
- Example of switching an MSC link from VTAM to TCP/IP
 1. Existing VTAM link in stage 1 sysgen

```
PLNK1  MSPLINK  TYPE=VTAM,NAME=L6APPL1,SESSION=1,BUFSIZE=8192  
  
LNK12  MSLINK  PARTNER=AK,MSPLINK=PLNK1,OPTIONS=FORCSESS  
  
MSN12  MSNAME  SYSID=(20,10)
```

2. Add a TCP/IP physical link to stage 1

```
PLNK2  MSPLINK  TYPE=TCPIP,NAME=IMS2,LCLICON=ICON1,  
        LCLPLKID=MSC12,SESSION=1,BUFSIZE=8192
```

Setup Scenario ...

3. Add the MSC and RMTIMSCON configuration statements to the local IMS Connect configuration proclib member

```
MSC=(LCLPLKID=MSC12,RMTPLKID=MSC21,LCLIMS=IMS1,RMTIMS=IMS2,  
      IMSPLEX=(MEMBER=HWS1,TMEMBER=PLEX1),RMTIMSCON=CONNECT2)  
RMTIMSCON=(ID=CONNECT2, HOSTNAME=ICON2.IBM.COM,PORT=9999,RSVSOC=2)
```

4. Add an SCI and OM (optionally) if not already defined
5. Stop the physical and logical links and move the logical link from VTAM to TCP/IP

(Repeat steps 1 through 5 for the remote IMS)

6. Restart the links

Falling Back from TCP/IP to VTAM

- If a fallback is needed
 1. Stop the physical TCP/IP links and associated logical links
 2. Move the logical links from the TCP/IP physical links back to the MSC VTAM physical links
 3. Restart the MSC VTAM links and logical links

MSC TCP/IP Error Handling

- Error handling technique for errors detected by MSC TCP/IP is to:
 - Issue an error message(s) to the MTO when then error is detected
 - DFS3175E AN MSC CSLSCMSG REQUEST FAILED
 - DFS3176E ICON ERROR MESSAGE RECEIVED
 - DFS3177E MSC DETECTED AN ERROR
 - DFS3178E MSC DETECTED AN INTERNAL LOGIC ERROR
 - Snap 6701-MSS1, MSS2, and MSS3 log records to the IMS log
 - Terminate the link connection (shutdown the link)
 - Set the link status to PSTOPPED IDLE on both sides of the link
 - send a shutdown immediate message to the partner
 - If the partner cannot be notified, it will remain in active status
 - /PSTOP LINK FORCE or UPDATE MSLINK STOP(COMM) OPTION FORCE command can be issued to disconnect the partner side of the link and place it in PSTOPPED IDLE status.

Performance Considerations (sample performance test)

- **Benchmark both VTAM and TCP/IP**
 - Query the MSC statistics for comparison numbers
 1. **Queue up 10,000 messages to the link**
 2. **UPDATE MSLINK NAME(name) START(STATISTICS) OPTION (NORESET, CHKPT)**
 - IMS will not reset the query statistics at each IMS checkpoint
 3. **UPDATE MSLINK NAME(name) START(STATISTICS) OPTION (RESET)**
 - IMS will reset the link statistics to zero and set the start time to the current time
 - (Only for VTAM): 4. **UPDATE MSLINK NAME(name) SET(BANDWIDTH(ON))**
 - IMS will set bandwidth on for VTAM (TCP/IP always uses BANDWIDTH)
 5. **UPDATE MSLINK NAME(name) START(COMM)**
 - IMS will start the link and let all the messages process (Msgs sent one way)
 6. **QUERY MSLINK NAME(name) SHOW(STATISTICS)**
 - Look at Send_Msg_Time - Interval of time between the first and last message sent. Used for benchmark testing of a block of messages. Can also use Rec_Msg_Time.
 7. **Repeat steps 1-6 with larger buffer sizes**

Performance Considerations

- Expect TCP/IP Bandwidth to improve over VTAM
- Verify results using the QUERY MSLINK SHOW (STATISTICS)
Current statistics support includes:
 - General statistics
 - Total ITASK dispatch count, Total processing time. Hi, Lo, Avg processing times per dispatch, check write counts and rates
 - Send statistics
 - Total messages sent, total byte count sent, Hi, Lo, Avg send message sizes, queue manager get (QGET) counts (GU, GN, DEQ calls,), and Hi, Lo, Avg QGET times, and Hi, Lo, Send I/O times
 - Receive statistics
 - Total messages received, total byte count received, Hi, Lo, Avg receive message sizes, QMGR ISRT (QPUT) counts (ISRT, and ENQ calls), Hi, Lo, Avg QPUT and times, and Hi, Lo, Receive I/O times

Enhanced I/O Statistics

- Enhanced Query MSLINK Show (Statistics)
 - Added elapsed times for SCIs, ICONs, and TCPIP
 - I/O statistics reported in SCI, ICON, and TCP/IP elapsed times
 - SendIO_Times
 - Tot_SCI_SendIO_Time, Tot_ICON_SendIO_Time, Tot_TCPIP_SendIO_Time ...
 - Hi_SCI_SendIO_Time, Hi_ICON_SendIO_Time, Hi_TCPIP_SendIO_Time ...
 - Low_SCI_SendIO_Time, Low_ICON_SendIO_Time, Low_TCPIP_SendIO_Time ...
 - ReceiveIO_Times
 - Tot_SCI_ReclO_Time, Tot_ICON_ReclO_Time, Tot_TCPIP_ReclO_Time...
 - Hi_SCI_ReclO_Time, Hi_ICON_ReclO_Time, Hi_TCPIP_ReclO_Time...
 - Low_SCI_ReclO_Time, Low_ICON_ReclO_Time, Low_TCPIP_ReclO_Time...

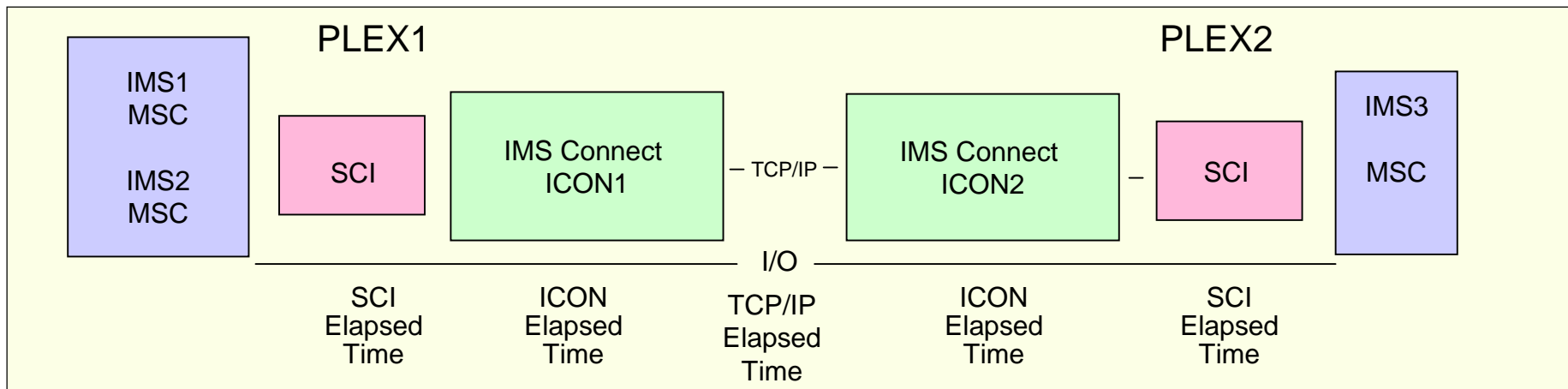

Query MSLINK Enhanced I/O Statistics

QUERY MSLINK NAME(LNK12T01) SHOW(ALL)

MSLink	MSLink#	MbrName	CC	MSPLink	PID	RecdCnt	SentCnt	BufSize	Bandwidth	Affin
LNK12T01	22	IMS1	0	PLNK12TA	TA	0	2	65536	ON	

QUERY MSLINK NAME(LNK12T01) SHOW(STATISTICS)

MSLink	MSLink#	MbrName	CC	Option	Start_Time	Tot_Disp_CT	Tot_Proc_Time	Hi_Proc_Time
LNK12T01	22	IMS1	0	RESET,CHKPT	2010.209 11:52:59.39	16	0.020195	0.004190

MSLink	MSLink#	MbrName	Low_Proc_Time	Avg_Proc_Time	Chkw_CT	ChkwIO_CT	Chkw_Rate	Tot_Send_CT	Tot_Msg_Send_CT
LNK12T01	22	IMS1	0.000235	0.001262	5	2	0.000000	5	2

MSLink	MSLink#	MbrName	Tot_MsgByte_Send_CT	Tot_Byte_Send_CT	Hi_Msg_Send_SZ	Low_Msg_Send_SZ	Avg_Msg_Send_SZ
LNK12T01	22	IMS1	1,040	2,816	538	502	520

MSLink	MSLink#	MbrName	Send_Msg_Time	Send_MsgCT_Rate	Send_MsgByte_Rate	Tot_Qget_CT	Tot_Qget_Time	Hi_Qget_Time
LNK12T01	22	IMS1	47.917786	30.472011	15,845.445957	6	0.000129	0.000043

MSLink	MSLink#	MbrName	Low_Qget_Time	Avg_Qget_Time	Tot_SendIO_Time	Hi_SendIO_Time	Low_SendIO_Time	SendIO_Req_Rate
LNK12T01	22	IMS1	0.000004	0.000021	0.052853	0.016744	0.011833	94.602009

MSLink	MSLink#	MbrName	SendIO_Byte_Rate	Tot_Loc_SCI_SendIO_Time	Hi_Loc_SCI_SendIO_Time	Low_Loc_SCI_SendIO_Time
LNK12T01	22	IMS1	53,279.851664	0.001503	0.000988	0.000103

Query MSLINK Enhanced I/O Statistics ...

MSLink	MSLink#	MbrName	SendIO_Byte_Rate	Tot_Loc_SCI_SendIO_Time	Hi_Loc_SCI_SendIO_Time	Low_Loc_SCI_SendIO_Time
LNK12T01	22	IMS1	53,279.851664	0.001503	0.000988	0.000103

MSLink	MSLink#	MbrName	Tot_Loc_ICON_SendIO_Time	Hi_Loc_ICON_SendIO_Time	Low_Loc_ICON_SendIO_Time
LNK12T01	22	IMS1	0.023818	0.008290	0.004861

MSLink	MSLink#	MbrName	Tot_TCPIP_SendIO_Time	Hi_TCPIP_SendIO_Time	Low_TCPIP_SendIO_Time	Tot_Rmt_ICON_SendIO_Time
LNK12T01	22	IMS1	0.003279	0.001210	0.000506	0.019013

MSLink	MSLink#	MbrName	Hi_Rmt_ICON_SendIO_Time	Low_Rmt_ICON_SendIO_Time	Tot_Rmt_SCI_SendIO_Time
LNK12T01	22	IMS1	0.005403	0.004312	0.019013

MSLink	MSLink#	MbrName	Hi_Rmt_SCI_SendIO_Time	Low_Rmt_SCI_SendIO_Time	Tot_Rec_CT	Tot_Msg_Rec_CT
LNK12T01	22	IMS1	0.005403	0.004312	5	3

MSLink	MSLink#	MbrName	Tot_MsgByte_Rec_CT	Tot_Byte_Rec_CT	Hi_Msg_Rec_SZ	Low_Msg_Rec_SZ	Avg_Msg_Rec_SZ
LNK12T01	22	IMS1	1,595	3,419	549	502	531

MSLink	MSLink#	MbrName	Rec_Msg_Time	Tot_Qput_CT	Tot_Qput_Time	Hi_Qput_Time	Low_Qput_Time	Avg_Qput_Time
LNK12T01	22	IMS1	235.933123	0	0.000000	0.000000	0.000000	0.000000

MSLink	MSLink#	MbrName	Tot_RecIO_Time	Hi_RecIO_Time	Low_RecIO_Time	RecIO_Req_Rate	RecIO_Byte_Rate
LNK12T01	22	IMS1	0.053281	0.014511	0.012323	93.842082	64,169.216043

And also some information regarding **UK54729(V10) UK54732 (V11) UK54730 (V12)**
 Added fields **Send_Msgct_Rate , Send_MsgByte_Rate** to compliment **Send_Msg_Time**
 to **QUERY MSLINK NAME(xxx) SHOW(STATISTICS)** for

- VTAM Link

```
cmd input. . . . . : QUERY MSLINK NAME(LLK78V26) SHOW(STATISTICS)
```

MSLink	MSLink#	MbrName	CC	Option	Start_Time	Tot_Disp_CT	Tot_Proc_Time	Hi_Proc_Time
LLK78V26	50	IMM7	0	NORESET,CHKPT	2010.020 14:54:25.39	1,893	0.865719	0.003529
Low_Proc_Time	Avg_Proc_Time	Chkw_CT	ChkwIO_CT	Chkw_Rate	Tot_Send_CT	Tot_Msg_Send_CT	Tot_MsgByte_Send_CT	
0.000001	0.000456	938	938	0.000000	938	9,999	5,639,436	
Tot_Byte_Send_CT	Hi_Msg_Send_SZ	Low_Msg_Send_SZ	Avg_Msg_Send_SZ	Send_Msg_Time	Send_Msgct_Rate	Send_MsgByte_Rate		
7,303,426	564	564	564	120.512383	82.974488	46,797.611290		
Tot_Qget_CT	Tot_Qget_Time	Hi_Qget_Time	Low_Qget_Time	Avg_Qget_Time	Tot_SendIO_Time	Hi_SendIO_Time	Low_SendIO_Time	
19,999	0.123673	0.001091	0.000000	0.000006	103.628331	22.389010	0.001128	
SendIO_Req_Rate	SendIO_Byte_Rate	Tot_Rec_CT	Tot_Msg_Rec_CT	Tot_MsgByte_Rec_CT	Tot_Byte_Rec_CT	Hi_Msg_Rec_SZ		
9.051578	70,477.116918	938	0	0	1,154,038	0		
Low_Msg_Rec_SZ	Avg_Msg_Rec_SZ	Rec_Msg_Time	Tot_Qput_CT	Tot_Qput_Time	Hi_Qput_Time	Low_Qput_Time	Avg_Qput_Time	
0	0	0.000000	0	0.000000	0.000000	0.000000	0.000000	
Tot_RecIO_Time	Hi_RecIO_Time	Low_RecIO_Time	RecIO_Req_Rate	RecIO_Byte_Rate				
8.192409	1.811653	0.000105	114.496236	140,866.746276				

Generic MSC name Support

TCP/IP Generic name support (similar to MSC VTAM VGR)

- Allows IMSs in a shared queues IMSplex, or XRF active/alternate pair to be represented by a common (generic) IMSID
 - Systems outside the IMSplex can use this generic IMSID (GENIMSID) to establish MSC link sessions with the IMSplex
 - Instead of using the IMSID of a specific IMS system in the IMSplex
- Simplifies moving MSC link sessions between IMS systems within the IMSplex
 - No change to the remote IMSID name on the NAME= parameter in the MSPLINK definition for each IMS system outside the IMSplex
- Works similarly to the MSC VTAM generic resources (VGR) support
 - And can coexist with VGR

TCP/IP Generic name support (similar to MSC VTAM VGR)

■ Implementation

– IMS

- Code **GENIMSID=generic_IMSID** on **IMS DFSDCxxx proclib** member for each IMS in the IMSplex.
- In the remote IMS's MSPLINK macro, use the *generic_IMSID* name as the IMSID in the NAME= parameter.

– IMS Connect

- Code **GENIMSID=generic_IMSID** in each **MSC statement** of configuration member.

TCP/IP Generic name Example: IMS1/IMS2 Generic Name = IMS

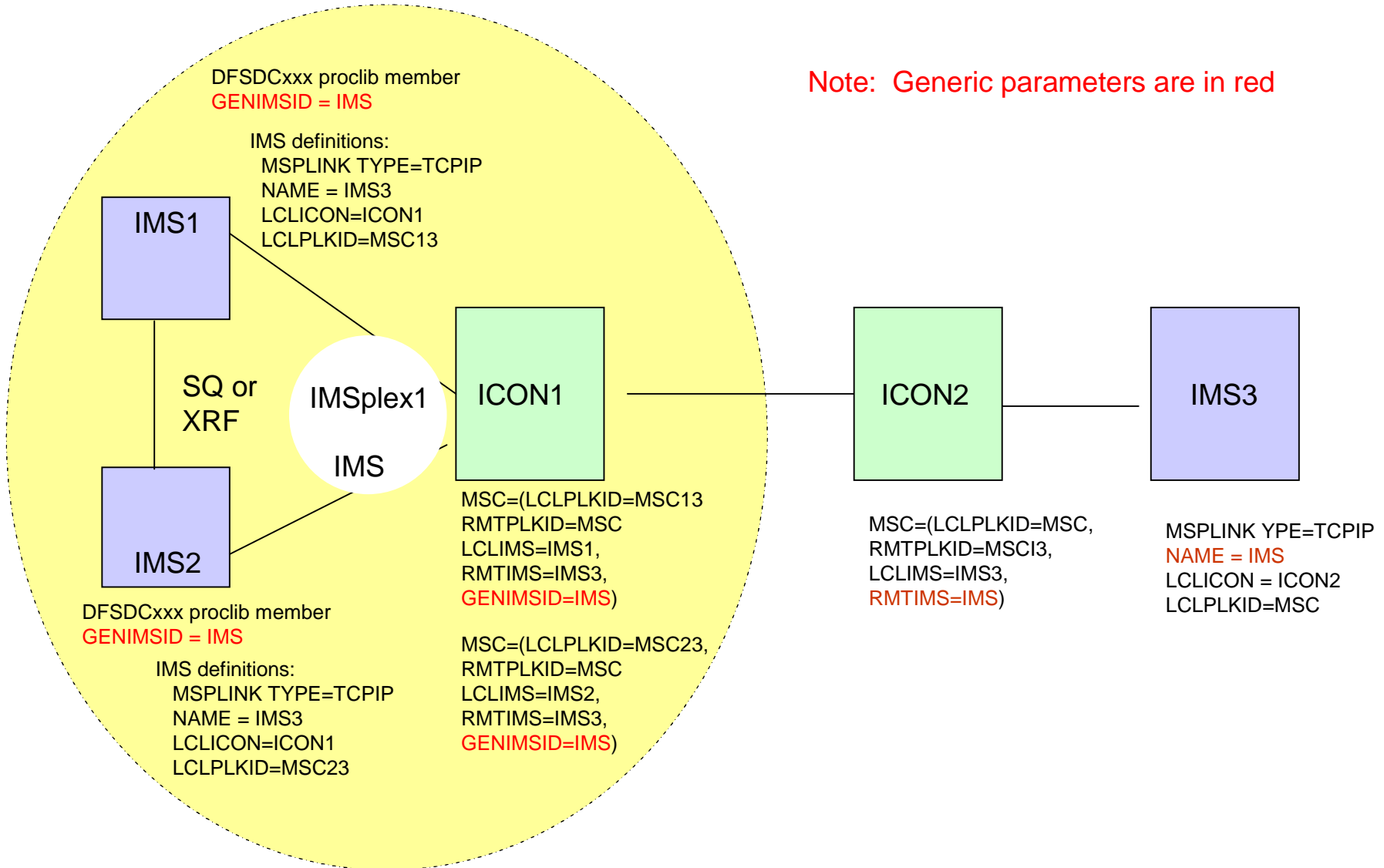

Affinities

- Characteristics (similar to affinities in the MSC VGR environment)
 - All the TCP/IP parallel sessions have affinity to the same IMS in the IMSplex
 - Affinity is removed when the last TCP/IP parallel session terminates normally
 - Affinities and GENIMSID can be displayed
 - /DIS ACTIVE and QUERY MSC commands display the GENIMSID
 - /DIS LINK and QUERY MSLINK commands display the affinity status

Affinities ...

■ Characteristics ...

- Affinities can be controlled when the link is first started by stopping the MSC path to the systems where an affinity is not desired
 - /STOP MSPLINK or UPDATE MSPLINK in IMS
 - UPDATE MSPLINK(name) START|STOP (GENIMSD) controls the generic IMSID
 - UPDATE MSPLINK(name) START|STOP (LOGON) controls the generic IMSID logons
 - STOPMSC in IMS Connect

- Optionally, establish affinity with a specific IMS system in the generic resource group by restarting the link from that specific IMS system

MSC TCP/IP - Benefits

- Benefits

- Takes advantage of TCP/IP networks for MSC
 - Can potentially provide for a higher MSC bandwidth
- Supports different configurations
 - Coexistence with or backup of VTAM/SNA links
 - Increases availability
 - Logical links can be moved between VTAM and TCPIP
 - Flexibility

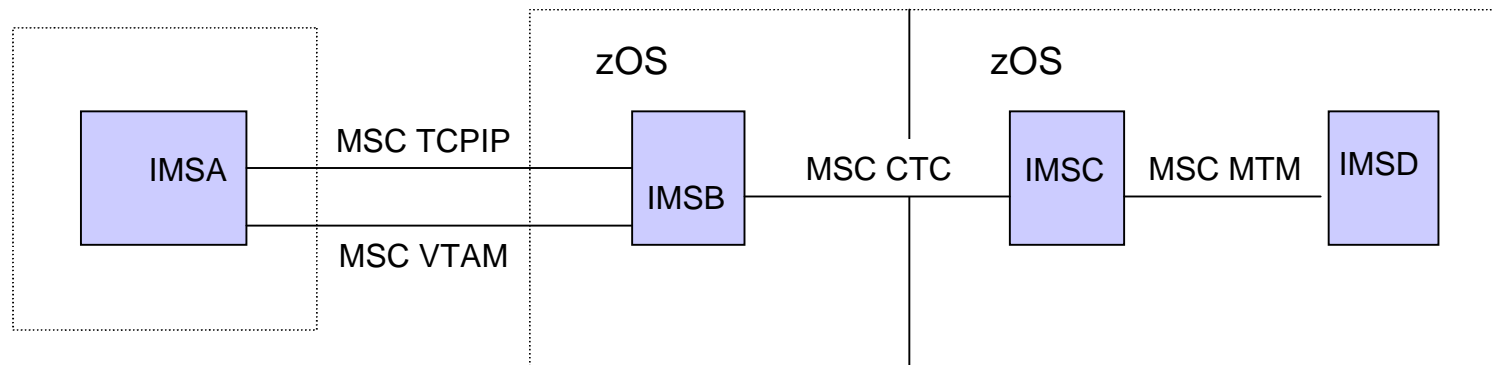

Reference Information

- IMS Commands
- IMS Messages
- IMS Connect Commands
- Trace records
- Additional Error Scenarios

IMS Commands

- /DISPLAY LINK and /DISPLAY LINK OPTION BUFSIZE
 - No change but TCP/IP links only support BANDWIDTH mode

```
/DIS LINK 4
```

```
Response:
```

LINK	PARTNER	RECD	ENQCT	DEQCT	QCT	SENT			
4	TA	0	0	0	0	0	PSTOPPED	IDLE	COLD

```
/DIS LINK 4 OPTION BUFSIZE
```

```
Response:
```

LINK	LINKNAME	BUFSIZE	STATUS			
4	LNK12T01	8192	PSTOPPED	IDLE	COLD	BANDWIDTH

IMS Commands ...

- /DISPLAY ASSIGNMENT MSPLINK
 - Now also includes TCP/IP physical links

```
/DIS ASMT MSPLINK ALL
```

Response:

LINK	PLINK	TYPE	ADDR	MAXSESS	NODE
3	PLNK12M	MTM	****		
2	PLNK12C	CTC	0511		
1	PLNK12V	VTAM	02000006	3	L6APPL1
4	PLNK12TA	TCPIP	****	2	IMS2

IMS Commands ...

- UPDATE MSPLINK
 - New parameters for the TCP/IP environment

```

ÊÊ-----UPDATE-----MSPLINK-----
  -UPD-----
                                     ~-----®-----
                                     a-NAME(-----msplinkname-----)«
                                     -msplinkname*-----
                                     -NAME(*)-----

Ê-----A-----
  a-----START(-----LOGON-----)«
  -----STOP(-----LOGON-----)-----

A:
  ~-----
  a-----SET(-----ASR(-----ON-----)-----
  -OFF-----
  a-----ICONPLKID(-----TCPIP_local_IMSconnect_MSC_configuration_statement_name-----)-----
  a-----IMSCON(-----TCPIP_local_IMSconnect_member_name-----)-----
  a-----MODETBL(-----)-----
  -----modetablename-----
  a-----MSPLINK(-----new_msplinkname-----)-----
  a-----NODE(-----VTAM_node_name-----)-----
  -----RMTIMS(-----TCPIP_remote_IMS_name-----)-----

```

IMS Commands ...

- QUERY MSPLINK

- Output shows the new parameters for the TCP/IP environment

```
/QUERY MSPLINK TYPE(TCPIP) SHOW(ALL)
```

Response:

MSPLink	MbrName	CC	Type	RmtIms	LclImsCon	LclPlkID	LclStat
PLNK31TA	SYS3	0	TCPIP	IMS1	ICON3	MSC31	
PLNK32TA	SYS3	0	TCPIP	IMS2	ICON3	MSC32	

IMS Connect Commands

- Enhanced **WTOR** and **z/OS Modify** commands
 - **VIEWHWS** and **QUERY MEMBER TYPE(IMSCON)**
 - **VIEWPORT** and **QUERY PORT**
 - **STOPIP** and **UPDATE IMSPLEX NAME(*plexname*) STOP(COMM)**
 - **STARTIP** and **UPDATE IMSPLEX NAME(*plexname*) START(COMM)**
- **New WTOR** and **z/OS Modify** commands
 - **VIEWRMT** and **QUERY RMTIMSCON**
 - **STOPRMT** and **UPDATE RMTIMSCON STOP(COMM)**
 - **STARTRMT** and **UPDATE RMTIMSCON START(COMM)**
 - **STOPSCLN** and **DELETE RMTIMSCON SENDCLNT**
 - **VIEWMSC** and **QUERY MSC**
 - **STOPMSC** and **UPDATE MSC STOP(COMM)**
 - **STARTMSC** and **UPDATE MSC START(COMM)**
 - **STOPLINK** and **DELETE LINK**

IMS Connect Commands ...

- **Enhancements** to **STOPIP** and **UPDATE IMSPLEX NAME(*plexname*) STOP(COMM)**
 - Disables communication with the IMSplex
 - If the IMSplex is used for **MSC**
 - IMS Connect disconnects the send and receive clients used on the MSC physical link
 - IMS Connect sends MSC level shutdown directive to MSC
 - IMS MSC cleans up physical link.
 - IMS issues DFS3176E message
 - IMS Connect's MSC status is set to DISCONNECT
- **Enhancements** to **STARTIP** and **UPDATE IMSPLEX NAME(*plexname*) START COMM)**
 - Enables communication with the IMSplex
 - If the IMSplex is used by **MSC**
 - IMS Connect's MSC status is set to ACTIVE

IMS Connect commands ...

- **VIEWRMT and QUERY RMTIMSCON**
 - Displays the new RMTIMSCON configurations values
 - RMTIMSCON status
 - ACTIVE – there is at least one socket connection to the remote IMS Connect
 - NOT ACTIVE – there is no socket connection to the remote IMS Connect
 - STOPPED – a STOPRMT command has stopped communications to the remote IMS Connect
 - Displays connection activity to the remote IMS Connect
 - Supports wildcards

IMS Connect commands ...

- VIEWRMT and QUERY RMTIMSCON example 1

IMS to IMS connections

```
nnVIEWRMT ALL
F HWS1,QUERY RMTIMSCON NAME(*)

HWSC0001I RMTIMSCON=ICON1      STATUS=ACTIVE
HWSC0001I IP-ADDRESS=009.030.221.055  PORT=5555
HWSC0001I HOSTNAME=ECSER14.VMEC.SVL.IBM.COM
HWSC0001I AUTOCONN=N  PERSISTENT=N
HWSC0001I IDLETO=3000
HWSC0001I RESVSOC=4  NUMSOC=2
HWSC0001I SENDCLNT USERID  STATUS  SECOND SENDPORT
HWSC0001I OTM62A45 USER01  CONN      13 5421
HWSC0001I OTMD18BE USER02  CONN      5454 6792
HWSC0001I TOTAL SENDCLNTS=2 RECV=0 CONN=2 XMIT=0
OTHER=0
```

MSC connections

```
nnVIEWRMT ALL
F HWS1,QUERY RMTIMSCON NAME(*)

HWSC0001I RMTIMSCON=ICON2      STATUS=ACTIVE
HWSC0001I IP-ADDRESS=009.030.221.055  PORT=5555
HWSC0001I HOSTNAME=ECSER14.VMEC.SVL.IBM.COM
HWSC0001I AUTOCONN=N  PERSISTENT=Y
HWSC0001I IDLETO=0
HWSC0001I RESVSOC=2  NUMSOC=2
HWSC0001I SENDCLNT LCLPLKID STATUS  SECOND SENDPORT
HWSC0001I MSC93D68 MSC12  CONN      1973 5555
HWSC0001I MSC3C970 MSC12  CONN      2026 5555
HWSC0001I TOTAL SENDCLNTS=2 RECV=0 CONN=2 XMIT=0
OTHER=0
```

IMS Connect commands ...

- **STOPRMT and UPDATE RMTIMSCON STOP(COMM)**
 - Stop communications to the remote IMS Connect for the RMTIMSCON
 - All existing socket connections are closed
 - RMTIMSCON status set to STOPPED state
 - Supports wildcard

IMS Connect commands ...

- **STARTRMT and UPDATE RMTIMSCON START(COMM)**
 - Enable communications to the remote IMS Connect for the RMTIMSCON
 - RMTIMSCON status set to NOT ACTIVE from STOPPED state
 - Supports wildcard

IMS Connect Commands

- **STOPSCLN and DELETE RMTIMSCON SENDCLNT...**
 - Terminates a client connection to the remote IMS Connect
 - Only valid for connections used for OTMA remote ALTPCB messages
 - Supports wildcard
 - If issued when connection is in CONN state
 - IMS Connect disconnects send client socket and cleans up control blocks
 - Remote IMS Connect is notified of socket close by TCP/IP and cleanup of the control blocks occurs
 - If issued when connection is in RECV state
 - IMS Connect disconnects send client socket and cleans up control blocks
 - IMS Connect sends NAK with reroute to HWS\$DLQ to OTMA and issues HWST3570E message.
 - The Remote IMS Connect gets socket error when trying to send back ACK/NAK to local IMS Connect
 - Existing logic cleans up socket and associate control blocks

IMS Connect commands

- VIEWMSC and QUERY MSC

- Displays the new MSC configuration values
- MSC status
 - ACTIVE – communications to MSC for the physical link is enabled
 - NOT ACTIVE – communications to MSC for the physical link is disabled
- Displays MSC logical link activity of the MSC physical link
- Supports wildcard

```
nnVIEWMSC ALL
F HWS1, QRY MSC NAME(*)

HWSC0001I      MSC=MSC12      STATUS=ACTIVE
HWSC0001I      RMTPLKID=MSC21
HWSC0001I      LCLIMSID=IMS1      RMTIMSID=IMS2
HWSC0001I      IMSPLEX=PLEX1
HWSC0001I      MEMBER=HWS1      TARGET MEMBER=PLEX1
HWSC0001I      RMTIMSCON=ICON2
HWSC0001I      IP-ADDRESS=009.030.221.055  PORT=5555
HWSC0001I      HOSTNAME=EC SER14.VMEC.SVL.IBM.COM
HWSC0001I      LINK      PARTNERID  STATUS      SENDCLNT  RECVCLNT
HWSC0001I      LNK12T01  TA          ACTIVE      MSC3C970  MSCBB237
HWSC0001I      LNK12T02  TB          ACTIVE      MSC93D68  MSCC4B72
```

IMS Connect commands

- **STOPMSC and UPDATE MSC STOP(COMM)**
 - Stops communications for the MSC physical link
 - All existing logical links on the MSC physical link are terminated and reported to IMS
 - MSC status for the physical link set to NOT ACTIVE state
- **STARTMSC and UPDATE MSC START(COMM)**
 - Enables communications for the MSC physical link
 - RMTIMSCON status set to ACTIVE state
 - Supports wildcard
- **STOPLINK and DELETE LINK**
 - Terminates MSC logical link and reports to IMS
 - IMS Connect disconnects the associated send and receive clients
 - Terminates the socket connections used by the MSC logical link
 - Should also be issued on the remote IMS Connect

IMS Connect Recorder Trace

```

* .....ICONRS.....*
* .....*
* .....*IPB*
* OTMA prefix and Message from local IMS *
* .....*
* .....*OPB*
* IRM and Message from local IMS .....*
* .....*
    
```

Send message from local IMS to remote IMS Connect

```

* .....ICONMS.....*
* .....*
* .....*IPB*
* MSC Message from local IMS .....*
* .....*
* .....*OPB*
* IRM and MSC Message from local IMS .....*
* .....*
    
```

Send message from local IMS to remote IMS Connect

```

* .....ICONRR.....*
* .....*
* .....*IPB*
* IRM and Message from remote ICON .....*
* .....*
* .....*OPB*
* OTMA prefix and Message from remote ICON .....*
* .....*
    
```

Receive message from remote IMS Connect to local IMS

```

* .....ICONMR.....*
* .....*
* .....*IPB*
* IRM and MSC Message from remote ICON .....*
* .....*OPB*
* MSC Message from remote ICON .....*
* .....*
    
```

Receive message from remote ICON to local IMS

Recorder Events for recorder exit HWSTECL0

Event number	Event key	Event description
113	EVENT	Connected to remote IMS Connect.
114	EVENT, TPIPE, or PARTNERID	Disconnected from remote IMS Connect.
115	TPIPE or PARTNERID	Communications thread started for a remote IMS Connect connection.
116	TPIPE	Message received from OTMA for OTMA remote ALTPCB function.
117	TPIPE	Message sent to remote IMS Connect over TCP/IP for OTMA remote ALTPCB function.
118	TPIPE	Message received from remote IMS Connect over TCP/IP for OTMA remote ALTPCB function.
119	TPIPE	Message sent to OTMA for OTMA remote ALTPCB function.

Recorder Events for recorder exit HWSTECL0

Event number	Event key	Event description
120	PARTNERID	MSC message received from MSC.
121	PARTNERID	MSC message sent to remote IMS Connect.
122	PARTNERID	MSC message received from remote IMS Connect.
123	PARTNERID	MSC message sent to MSC.
124	TPIPE	Connection to remote IMS Connect timed out.

Additional Error Scenarios

- New request message during connection retries

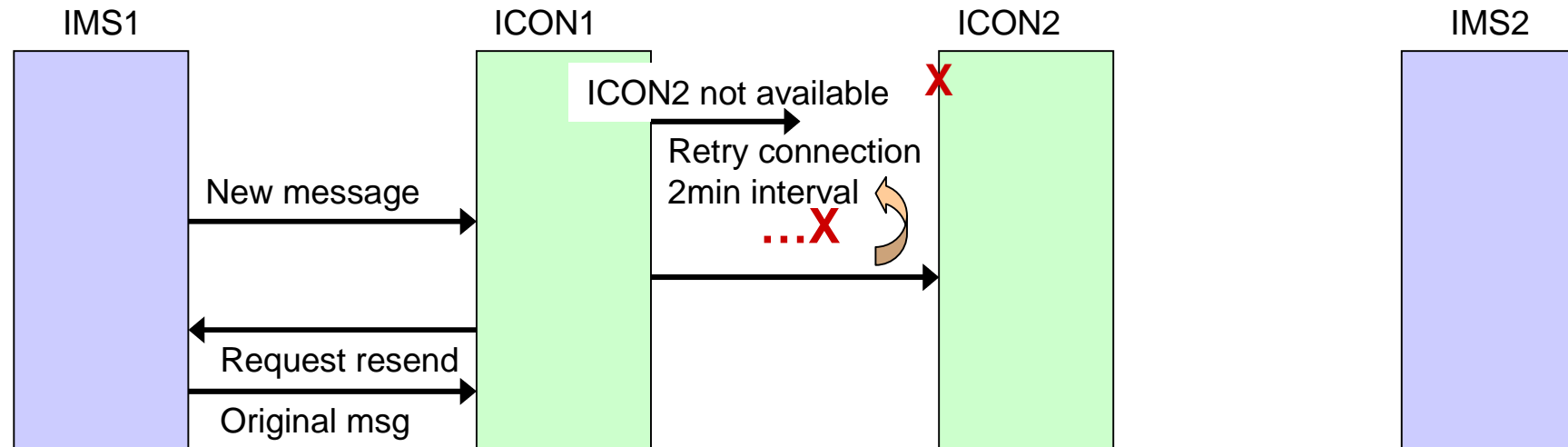

- In between connection retry attempts, a new message is received from OTMA
- Local IMS Connect attempts to make connection to remote IMS Connect
 - If successful, ICON1 cancels the previous ongoing retries and sends OTMA protocol to all connected IMS datastores to start sending messages that uses that RMTIMSCON

Additional Error Scenarios ...

- Local IMS Connect cleanup on persistent socket failures

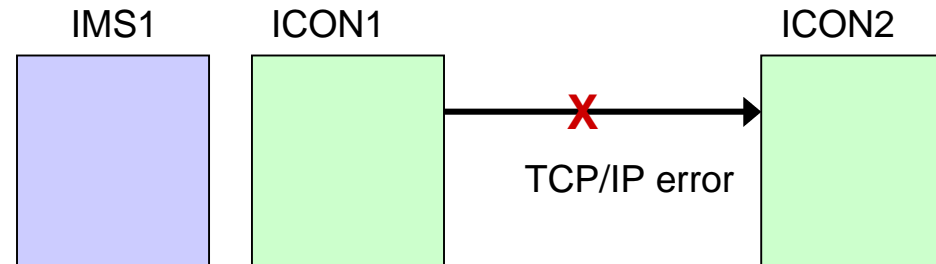

- Local IMS Connect detects that the socket is no longer valid when the remote IMS Connect goes down or a TCP/IP failure occurs
 - Cleans up the sockets
 - Connection is not displayed in VIEWRMT output.

Additional Error Scenarios ...

- IMS Connect startup detects an invalid name for the remote system

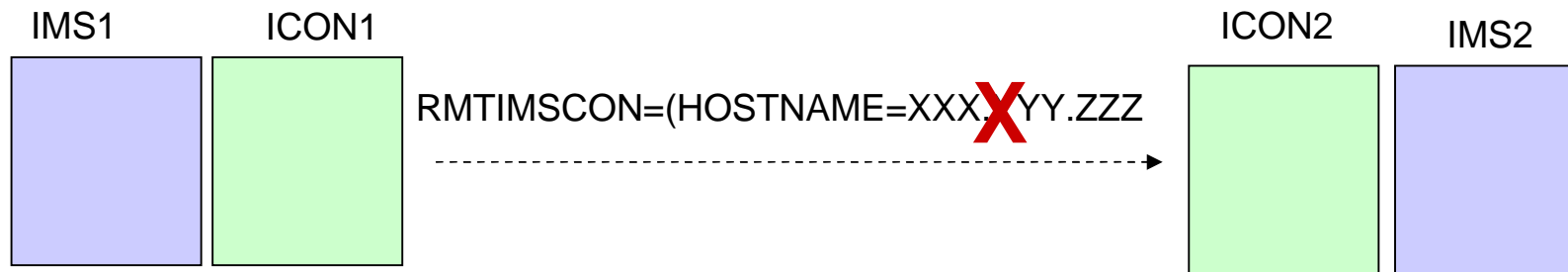

- The HOSTNAME parameter in the RMTIMSCON definition contains an invalid hostname
 - HWST3510E message is issued
 - HWST3510E COMMUNICATIONS WITH REMOTE IMS CONNECT rmtimscon FAILED TO START; R=rc, S=sc, M=mc
 - The thread and TCB of the RMTIMSCON is terminated
 - The RMTIMSCON status set in STOPPED state.
- To fix this problem, specify a valid hostname and restart IMS Connect.

Additional Error Scenarios ...

- Remote IMS Connect is unavailable during local IMS Connect startup

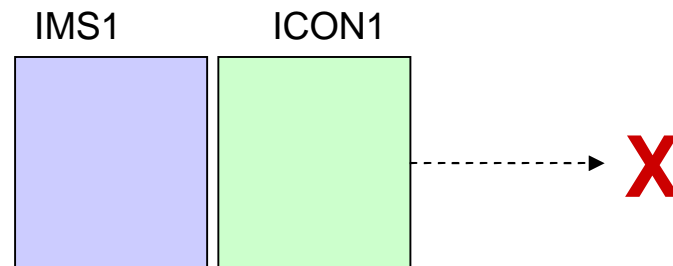

- In the RMTIMSCON statement of ICON1, the HOSTNAME parameter contains a valid hostname, but ICON2 is not started.
- AUTOCONN=Y connections will fail and new connections will fail with this error message issued:
 - HWST3700E TCP/IP SOCKET FUNCTION CALL FAILED; F=CONNECT , R=-1, E=1128, N=76630291, RIC=ICON2B , M=TDCO
- When remote IMS Connect is available, new connections will be made properly

Additional Error Scenarios ...

- Local TCP/IP support is unavailable during local IMS Connect startup

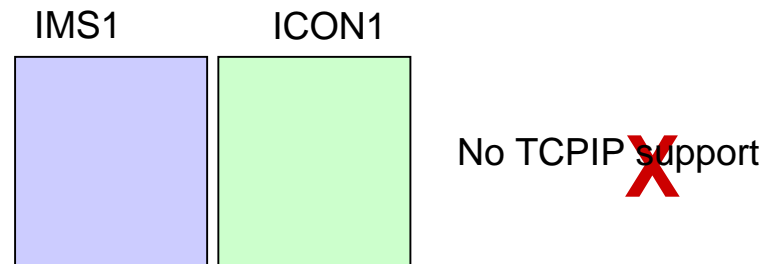

- On startup, ICON1 issues the following messages:
 - HWSS0785W OPEN TCPIP COMMUNICATION ON HOSTNAME=TCPIP FAILED; R=-1, S=112, M=SOC1 (existing message)
 - HWST3700E TCP/IP SOCKET FUNCTION CALL FAILED; F=GETIPADR, R=-1, E=1, N=78AE1004, RIC=ICON2B , M=TDOT (new V12 message)
 - HWST3510E COMMUNICATIONS WITH REMOTE IMS CONNECT ICON2B FAILED TO START; R=8, S=OPENTHRD, M=TSCH (new V12 message)
 - Terminate thread and TCB of the RMTIMSCON
 - RMTIMSCON status set in STOPPED state
- When local TCP/IP is available, issue STARTRMT in the local IMS Connect to enable communications with that RMTIMSCON.

Additional Error Scenarios ...

- Remote TCP/IP support is unavailable during local IMS Connect startup



- On Local IMS Connect startup, if AUTOCONN=Y is specified
 - ICON1 issues the following message after a 3 minute wait trying to connect to the remote ICON2:
 - HWST3700E TCP/IP SOCKET FUNCTION CALL FAILED; F=CONNECT , R=-1, E=1127, N=76630291, RIC=ICON2B , M=TDCO
 - RMTIMSCON status set in NOT ACTIVE state.
- When remote TCP/IP is available, new connections will be made properly.

Additional Error Scenarios ...

- Socket connection failures at startup for AUTOCONN=Y

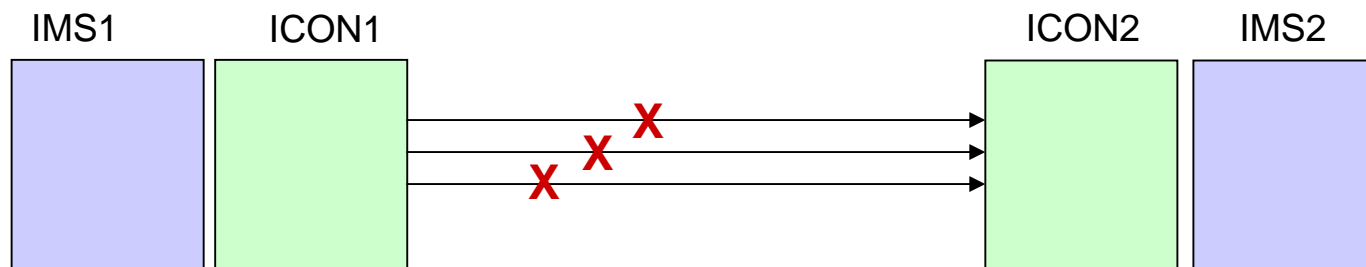

- Local IMS Connect
 - Issues HWST3700E message for each connection failure
 - HWST3700E TCP/IP SOCKET FUNCTION CALL FAILED; F=fn, R=rc, E=ec, N=rsn, RIC=ri, M=mc
 - Retries connection to remote IMS Connect every 2 minutes
- When successful retry occurs
 - The local IMS Connect sends OTMA protocol signal to all connected IMS datastores to start sending messages that use that RMTIMSCON

Additional Error Scenarios ...

- Socket connection error

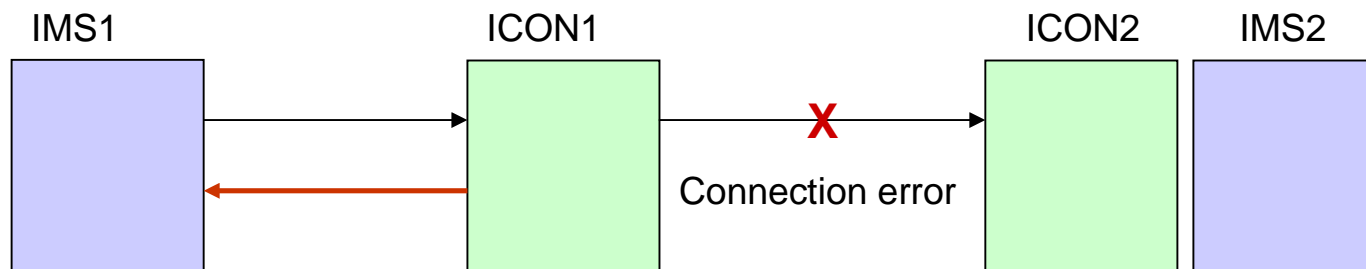

- Local IMS Connect
 - Issues HWST3700E message for each connection failure.
 - HWST3700E TCP/IP SOCKET FUNCTION CALL FAILED; F=fn, R=rc, E=ec, N=rsn, RIC=ri, M=mc
 - Sends NAK to OTMA and
 - If error is due to either a network problem or that the remote IMS Connect is not available
 - OTMA leaves message in front of queue.
 - Otherwise, for all other connection errors
 - OTMA reroutes the message to HWS\$DLQ queue.

Additional Error Scenarios ...

- RMTIMS validation error

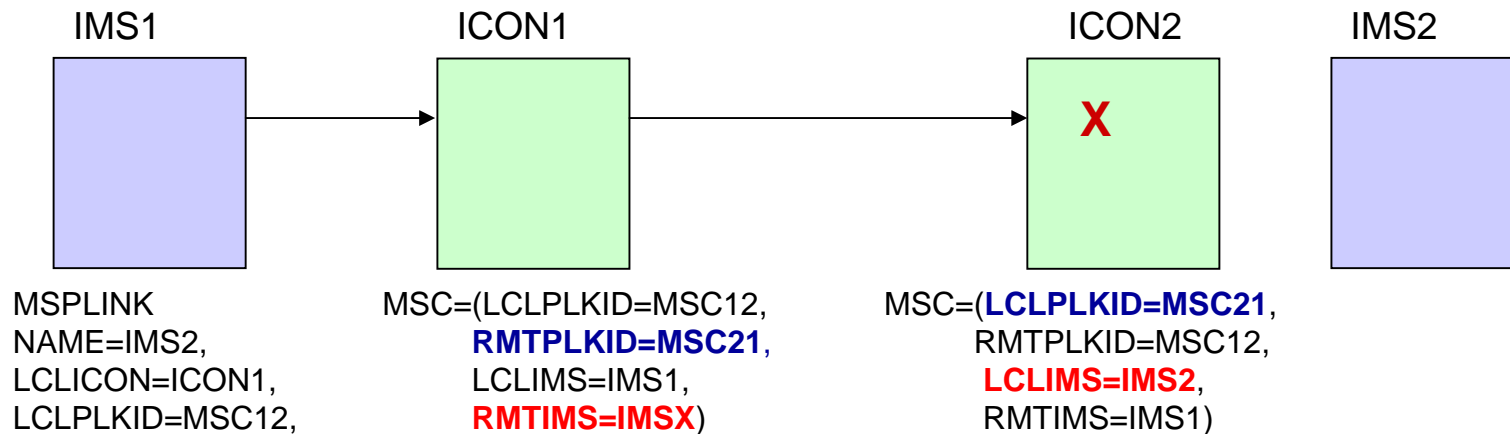

- Mismatch on validation that the RMTIMS value in the local IMS Connect is the same as the LCLIMS value in the Remote IMS Connect
 - On validation error, issue HWSS0742W message
 - HWSS0742W MESSAGE FAILURE, RECEIVED FROM ORIGIN=portid clientid TO DESTID=did, MBR=tmname; **R=16, S=MISMATCH**, M=mc
 - Also send error response message to the requesting MSC

Additional Error Scenarios ...

- Duplicate clientID received on remote IMS Connect

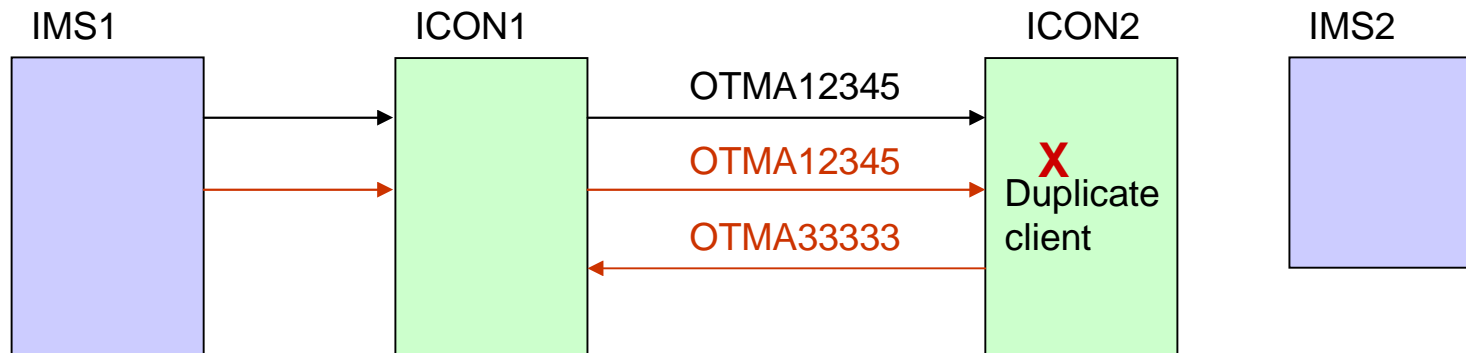

- When the local IMS Connect sends a message to the remote IMS Connect with a clientid
 - The CIDREQ option in the IRM is set which tells the remote IMS Connect to generate a new clientid if the one in the message is discovered to be a duplicate clientid
 - If a new clientid is generated in the remote IMS Connect then the value is sent back to the local IMS Connect on the ACK/NAK
 - ACK message format: LLLL{LLZZCID}|LLZZCSM
 - NAK message format: LLLL{LLZZCID}|LLZZRSM
 - CID mapping contains the new clientid