



# DB2 10 for z/OS Technical Overview

**Don Grossweiler**  
*DB2 for z/OS Development*

**Australia and ASEAN DB2 for z/OS Workshop Series**  
**August 2010**





## Disclaimer/Trademarks

*Information concerning non-IBM products was obtained from the suppliers of those products, their published announcements, or other publicly available sources. IBM has not tested those products and cannot confirm the accuracy of performance, compatibility, or any other claims related to non-IBM products. Questions on the capabilities of non-IBM products should be addressed to the suppliers of those products.*

***The information on the new products is intended to outline our general product direction and it should not be relied on in making a purchasing decision. The information on the new products is for informational purposes only and may not be incorporated into any contract. The information on the new products is not a commitment, promise, or legal obligation to deliver any material, code or functionality. The development, release, and timing of any features or functionality described for our products remains at our sole discretion.***

*This information may contain examples of data and reports used in daily business operations. To illustrate them as completely as possible, the examples include the names of individuals, companies, brands, and products. All of these names are fictitious, and any similarity to the names and addresses used by an actual business enterprise is entirely coincidental.*

*Trademarks The following terms are trademarks or registered trademarks of other companies and have been used in at least one of the pages of the presentation:*

*▪The following terms are trademarks of International Business Machines Corporation in the United States, other countries, or both: DB2 Universal Database, eServer, FlashCopy, IBM, IMS, iSeries, Tivoli, z/OS, zSeries, Guardium, IBM Smart Analytics Optimizer, Data Encryption Tool for IMS and DB2 Databases, DB2 Administration Tool / DB2 Object Compare for z/OS, DB2 Audit Management Expert for z/OS, DB2 Automation Tool for z/OS, DB2 Bind Manager for z/OS, DB2 Change Accumulation Tool for z/OS, DB2 Cloning Tool for z/OS, DB2 High Performance Unload for z/OS, DB2 Log Analysis Tool for z/OS, DB2 Object Restore for z/OS, DB2 Path Checker for z/OS, DB2 Query Management Facility for z/OS, DB2 Query Monitor for z/OS, DB2 Recovery Expert for z/OS, DB2 SQL Performance Analyzer for z/OS, DB2 Table Editor for z/OS, DB2 Utilities Enhancement Tool for z/OS, DB2 Utilities Suite for z/OS, InfoSphere Change Data Capture, InfoSphere Data Event Publisher, InfoSphere Replication Server, Optim Data Growth Solution for z/OS, Optim Development Studio, Optim pureQuery Runtime, Optim Query Workload Tuner, Optim Test Data Management Solution for z/OS, Tivoli OMEGAMON XE for DB2 Performance Expert on z/OS*

*▪EMC and TimeFinder are trademarks of EMC Corporation*

*▪Hitachi is a trademark of Hitachi Ltd*

*Microsoft, Windows, Windows NT, and the Windows logo are trademarks of Microsoft Corporation in the United States, other countries, or both.*

*Java and all Java-based trademarks are trademarks of Sun Microsystems, Inc. in the United States, other countries, or both.*

*Other company, product, or service names may be trademarks or service marks of others.*



## Business Value Pain Points

- **I am under constant cost pressures**
  - Performance improvements in key workloads: transactions, batch, ...
  - Synergy with System z to help reduce costs
  
- **I need DB2 to be able to scale with my business**
  - Many more concurrent users, simpler growth
  - Reduce DBA workload, eliminate time-consuming tasks
  
- **I need to improve the resilience of my data**
  - More online, more secure
  - Easier privileges with finer granularity authority
  - Ability to have administrators without data access, better auditing



# DB2 for z/OS Into the Future Delivering Customer Value

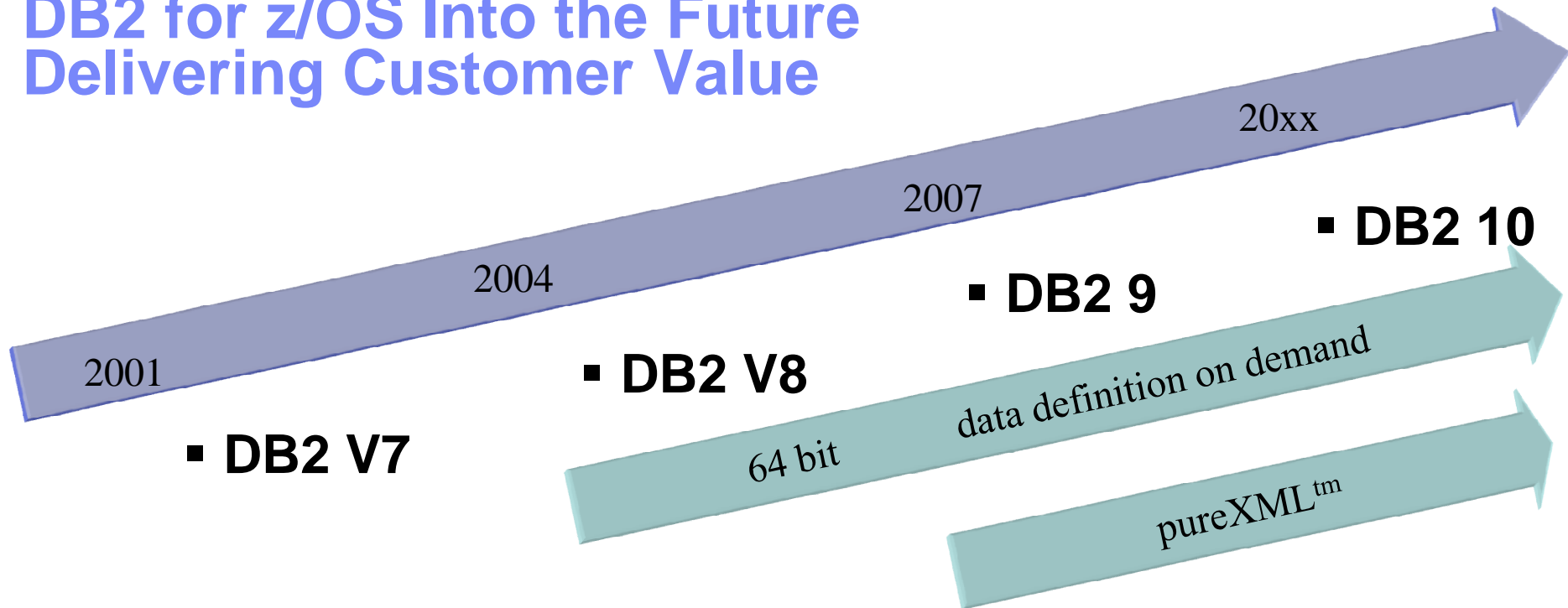

Ongoing themes:  
Performance Scalability  
Reliability Availability Serviceability  
Security Productivity  
Application Development  
SQL XML



## DB2 for z/OS Technical Strategy

- **RAS (reliability, availability, serviceability), scalability and performance.**
  - Extend the lead in this technology
  - Parallel Sysplex: the best scale-out solution in the industry
  - Tight integration between DB2 and the System z hardware and z/OS operating system
  - Advanced solutions for compliance with data security and privacy regulations
  - Workload consolidation: System z is the ultimate consolidation platform
  - Eliminate all causes of outages
  - Storage and CPU optimization, including specialty engines
  
- **Application enablement**
  - Apps can easily connect to DB2 from anywhere
  - Application portability and DB2 family compatibility
  - Advanced SQL, XML capability.
  - Advanced data warehousing and analytics capabilities
  
- **User Productivity**
  - DB technology that can handle larger workloads without requiring more people
  - Easy to use interfaces that are clear and intuitive
  - Advanced autonomies to make the system more self-managing and self-tuning



## DB2 Deep Synergy With System z

### ➤ Key integration points include:

- Data sharing (availability and scale out)
- zIIP and other specialty engines
- Unicode conversion
- Encrypted communication & data
- Hardware data compression & encryption
- Cross-memory, memory protection keys
- Sorting
- Multi-core, large N-way
- 64-bit addressing and large memory
- z/OS Workload Manager
- z/OS Security Server (RACF)
- z/OS RRS integrated commit coordinator
- System z10 1 MB page size, decimal float
- Solid state disks
- zEnterprise ...

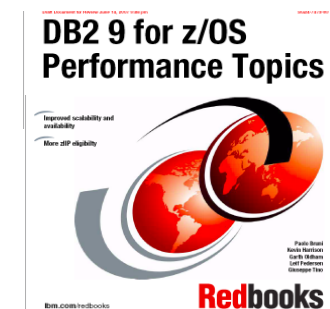



## System zEnterprise Benefits for DB2

### *Taking System z to the next level*

- Faster CPUs, more CPUs, more memory → better DB2 performance, scalability
- Compression hardware expected to increase DB2 data compression performance
- Cache optimization, 192M L4 Cache expected to benefit DB2 work
- Hybrid architecture query performance acceleration with IBM Smart Analytics Optimizer
- Excellent synergy with DB2 10 → significant cost reduction and scalability increase
  - CPU reductions
  - Remove key single system scaling inhibitors: virtual storage, latching
  - Translation Lookaside Buffer changes expected to improve performance for 1MB page sizes
  - Buffer pool management





# Mainframe Innovation: Specialty Engines

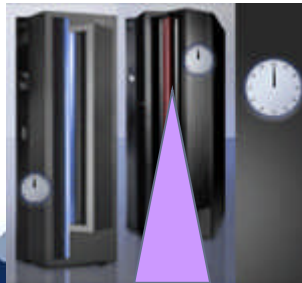

Internal Coupling Facility (ICF) 1997



Integrated Facility for Linux® (IFL) 2000

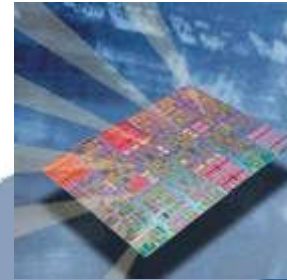

System z Application Assist Processor (zAAP) 2004



IBM System z Integrated Information Processor and (2006)

## Eligible for zAAP:

- Java execution environment
- z/OS XML System Services

## Eligible for zIIP:

- DB2 remote access, XML, parallel query, utilities (index & sort)
- ISVs
- IPsec encryption
- XML System Services
- Global Mirror (XRC)
- HyperSockets for large messages (e.g. DRDA)
- IBM GBS Scalable Architecture for Financial Reporting
- z/OS CIM Server
- zAAP on zIIP

\* Statements represent the current intention of IBM. IBM development plans are subject to change or withdrawal without further notice.





## DB2 & IBM zIIP Add Value to Database Work

Portions of the following DB2 for z/OS V8, DB2 9 and 10 workloads may benefit from zIIP (DB2 9 in blue, DB2 10 in green)\*:

### 1 - DRDA over TCP/IP connections

- DB2 9 for z/OS Remote native SQL procedures
- DB2 9 XML parsing via DRDA to fully utilize zIIP
- Increased portion of DRDA redirected to zIIPs to 60%

Improved performance via reduced processor switching

### 2 - Requests that use parallel queries

DB2 9 higher percentage of parallel queries zIIP eligible

DB2 10 still more queries eligible for parallelism

### 3 - DB2 Utilities LOAD, REORG & REBUILD

- DB2 utility functions used to maintain index structure and sort
- DB2 10 RUNSTATS

### 4 - DB2 10 Buffer Pool Prefetch



# IBM Smart Analytics Optimizer

## What is it?

- A special purpose, network-attached appliance that is an add-on to a DB2 for z/OS system
- Offloads typical DW/BI queries resulting in predictable and orders-of-magnitude faster query response times while reducing overall TCO

## Business Value

- Dramatically lowers the cost for query and reporting on System z
- Advanced in-memory scale-out cluster technologies that keep the complete system centrally managed without having to change any requirements for BI applications
- Complements the many new Data Warehousing features in DB2 9 for z/OS
- Leverages the many new warehousing and business intelligence solutions now available on System z

## Targeted Uses for DB2 for z/OS customers:

- Requirements to accelerate a subset of their warehouse or reporting queries
- Looking for more insight and business intelligence from operational data
- Needs to consolidate datamarts or data stores into one enterprise warehouse





# The most robust and cost effective data server

## DB2

## DB2 9

## DB2 10



- Deep synergy with System z
- HW Compression
- Mixed workloads at high utilization

- 20%-30% Utility CPU savings
- Compress indexes, save 50% disk
- More CPU on specialty engines

- Save up to 20% CPU batch & transactions
- Query performance
- Hashed data access
- Skip-level migration



- Unmatched availability
- Unparalleled security
- Industry leading reliability

- Flexible context and role security
- Expanded online schema changes
- Volume level backup & recovery improvements

- 10x more concurrent users
- More online schema changes
- More granular access control
- Access path stability



- Near-linear scalability
- Flexible development
- Warehousing capabilities

- Seamless integration of XML and relational
- Improved SQL
- Partition by growth
- OLAP expressions

- Temporal data
- More SQL features
- Improved pureXML and SQL PL

**DB2 10 Beta Started:  
March 12, 2010**



# DB2 10 for z/OS At a Glance

## Addressing Corporate Data Goals

### RAS, Performance, Scalability, Security

- Wide range of performance improvements
- More online schema changes
- Catalog restructure for improved concurrency
- Fine grained access control
- Hash access to data
- New DBA privileges with finer granularity
- Query parallelism advancements

### Simplification, Reduced TCO

- Full 64-bit SQL runtime
- Auto stats
- Data compression on the fly
- Query stability and management enhancements
- Reduced need for REORG
- Utilities enhancements
- More granular DDF thread management
- Statement level diagnostics

### Application Enablement

- pureXML enhancements
- SQLPL enhancements
- Temporal data
- Last Committed reads
- Timestamp with timezone
- Many new SQL features
- Moving sum, moving average



## DB2 10: Savings Out-of-the-Box

### Up to 20% CPU reductions for transactions, queries, and batch

- Out-of-the-box CPU reductions of 5-10% for traditional workloads
- Out-of-the-box CPU reductions of up to 20% for new workloads
- Up to additional 10% CPU savings using new functions



### Scales with less complexity and cost

- 5-10x more concurrent users – up to 20,000 per subsystem
- Significant scale-up capabilities in addition to existing scale-out support
- Consolidate to fewer LPARs and subsystems

### Improved operational efficiencies and lower administration cost

- Automatic diagnostics, tuning, and compression

### Even better performance

- Elapsed time improvement for small LOBS and Complex Queries



## DB2 10 Performance Objectives

- Historical goal under 5% performance regression
- DB2 10 Goal: 5% -10% initial performance improvement
- Many customers reduce CPU time 10% - 20%

Average %CPU improvements  
version to version

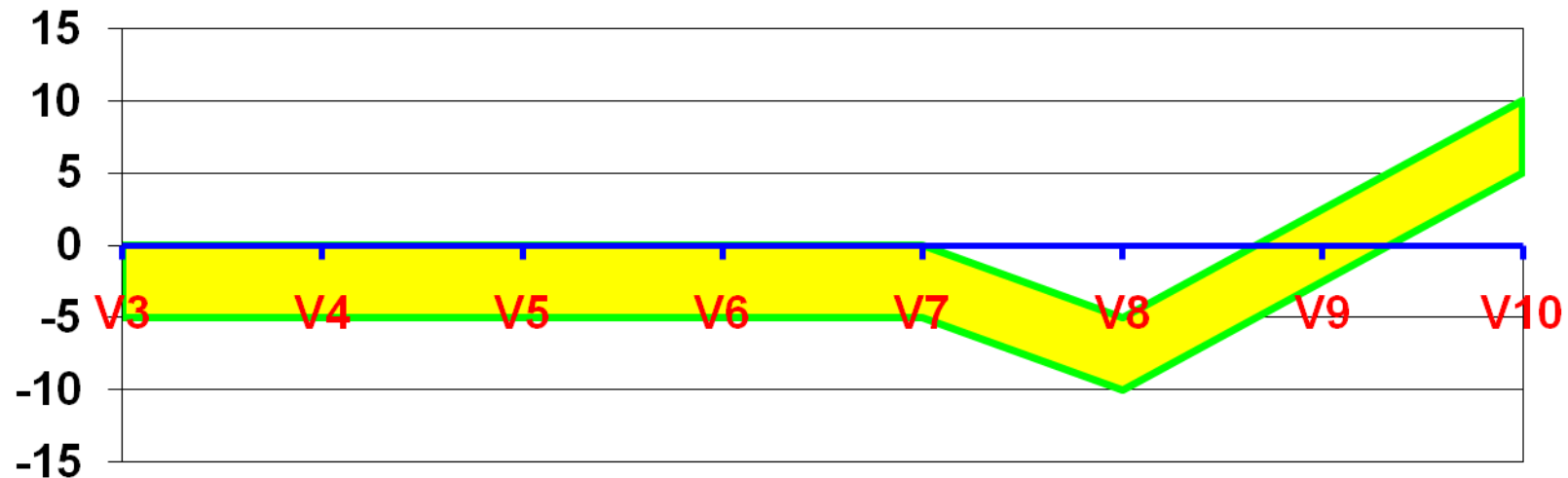



## Performance Enhancements w/Few Changes (CM)

- **SQL runtime improved efficiency**
- **Address space, memory changes to 64 bit, some REBINDs**
- **Faster single row retrievals via open / fetch / close chaining**
- **Distributed thread reuse High Performance DBATs**
  - **RELEASE(DEALLOCATE)** can be more aggressively used with V10 vstor relief
    - IBM measurements show up to 10-20% CPU savings
  - **DDF enforcement of RELEASE(COMMIT)** is removed
    - **KEEPDYNAMIC=YES** will not get benefit from this enhancement
- **DB2 9 utility enhancements in CM8**
- **Parallel index update at insert**
- **Workfile in-memory enhancements**
- **Index list prefetch**
- **Solid State Disk use**
- **Buffer pool enhancements**
  - Utilize z10 1MB page size
  - “Fully in memory” option (**ALTER BUFFERPOOL**)



## Parallel Index Update for INSERT

- **Beta Customer Test Results for 2M+ INSERTs into table with 9 indexes**
  - All jobs in DB2 10 CM9 have less CPU and less ELAPSED Time!
    - Would expect same results for CM8
  - The CPU improvement is between 15-30 percent
  - The Elapsed Time improvement is between 30-43 percent.
  - Depending on the size of the Bufferpool
    - Larger savings observed with smaller BPs
  - Some increase in DBM1 SRB time, but this is zIIP eligible





## Performance Enhancements requiring REBIND (CM)

- **Most access path enhancements**
- **SQL paging performance enhancements**
  - Single index access for complex OR predicates
- **IN list performance**
  - Optimized Stage1 processing (single or multiple IN lists)
  - Matching index scan on multiple IN lists
- **Query parallelism improvements**
- **More Stage 2 predicates can be pushed down to Stage 1**
- **More aggressive merge of views and table expressions**
  - Avoid materialization of views
- **REBIND enables further SQL runtime improvements**
- **If migrate from V8, get new RUNSTATS before mass rebind**



## Performance Enhancements requiring NFM

- **Efficient caching of dynamic SQL statements with literals**
- **Most utility enhancements**
- **LOB streaming between DDF and rest of DB2**
- **Faster fetch and insert, lower virtual storage consumption**
- **SQL Procedure Language performance improvements**
- **Workfile spanned records, PBG**
- **Insert improvement for UTS**
- **Local JDBC (Type 2) and ODBC application performance**
  - Limited block fetch, LOB progressive streaming, progressive CLOSE now available for JCC Type2 and ODBC z/OS drivers
- **Solid State Disk monitoring and exploitation**



## Performance Enhancements requiring NFM + DBA work

- **Hash access path**                    **Alter + Reorg + rebind to activate**
- **Index include columns**   **Alter + Rebuild + rebind to activate**
- **Inline LOBs**                        **Alter (need UTS and RRF)**
  - Index on expression now possible for LOB columns
  - Important for spatial performance
  - LOAD/UNLOAD performance improvements
  - LOB compression for inline portion
- **MEMBER CLUSTER for UTS**
- **DEFINE NO for LOB and XML columns**



# Index to Data Access Path

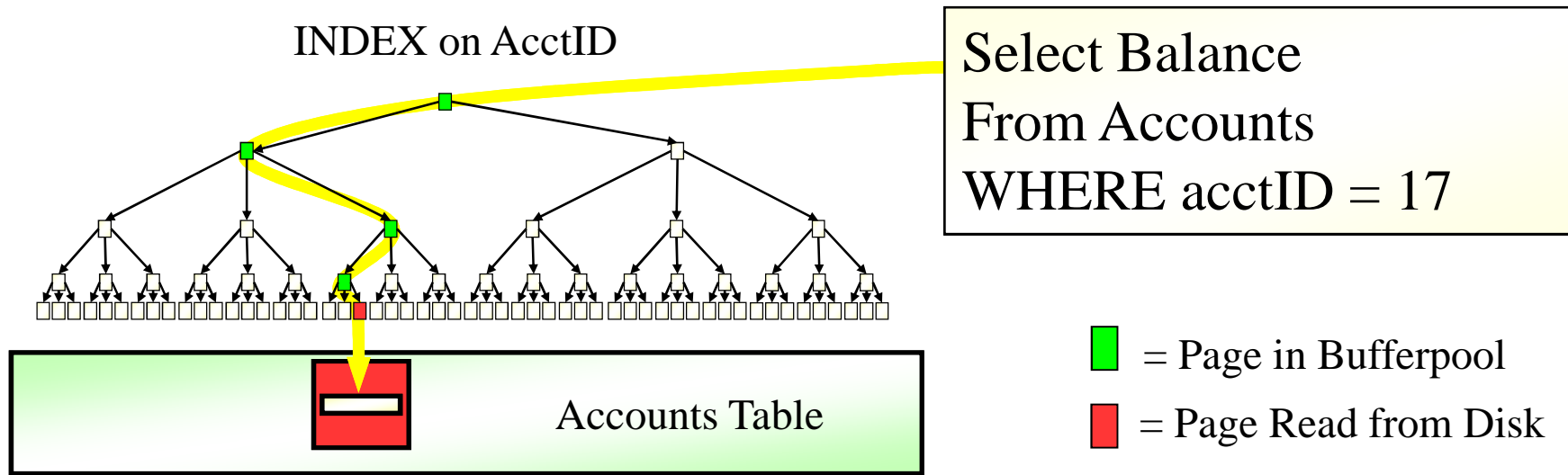

- **Traverse down Index Tree**
  - Typically non-leaf portion of tree in the bufferpool
  - Leaf Portion of the tree requires I/O
  - Requires searching pages at each level of the index
- **Access the Data Page**
  - Typically requires another I/O
- **For a 5 Level Index**
  - 6 GETP/RELPS, 2 I/O's, and 5 index page searches



## Hash Access

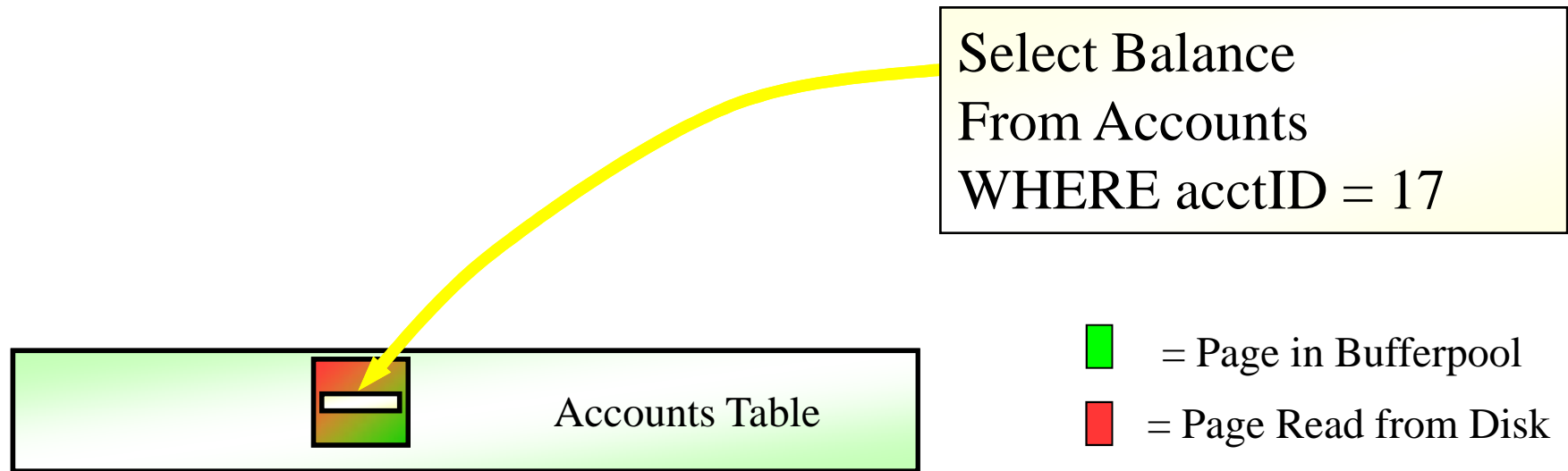

- **Hash Access provides the ability to directly locate a row in a table without having to use an index**
- **Single GETP/RELP in most cases**
- **1 Synch I/Os in common case**
  - 0 If In Memory Table
- **Greatly reduced Search CPU expense**



# Queries against Hashed Tables

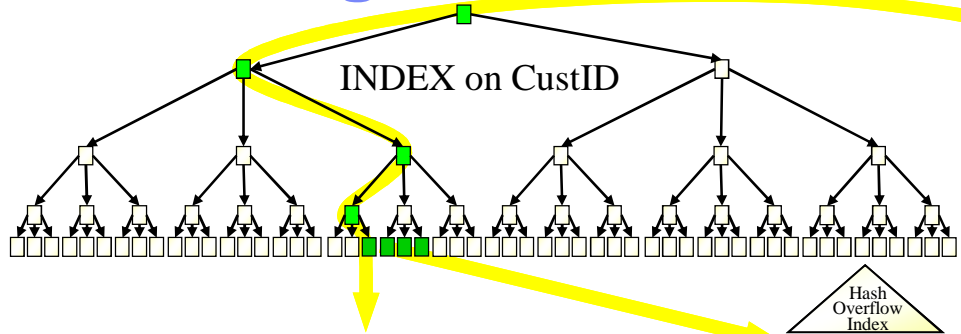

Index Lookup/Scan

Select Balance  
 From Accounts  
 WHERE CustID = 1717

Hash Access

Select Balance  
 From Accounts  
 WHERE AcctID = 17

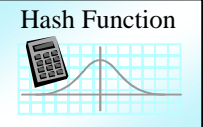

Table Space Scan

Select CustID  
 From Accounts  
 WHERE Balance > 100000

- **Hash Access Path**
  - Great for Equality and IN predicates
  - **Can't do range scans**
- **Secondary indexes can be defined for Range Scans**
- **Table Space Scans still supported**
- **Hash Access can be used to enforce Primary Key and Unique constraints**



## Hashing Summary

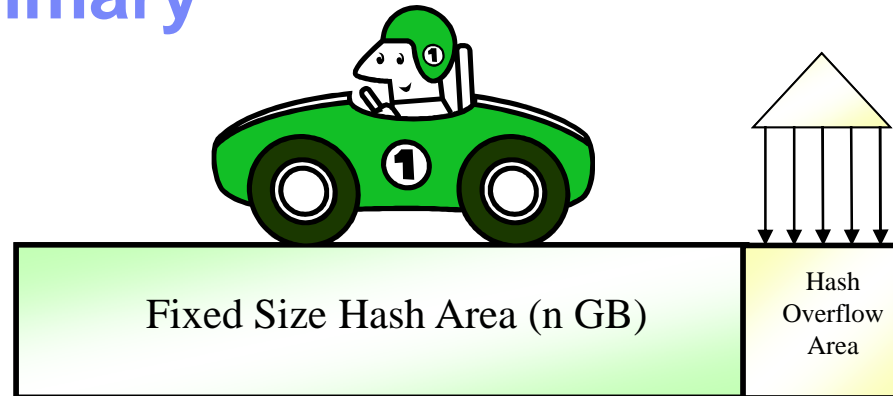

- **Provides fast, direct location of most rows**
  - Reduces I/O and CPU in most cases
  - Can replace an existing Primary or Unique Key Index
    - Faster Insertion/Deletion
- **Size of Fixed Size Hash Area is important**
  - Too small and performance degrades
  - Too large and space is wasted
- **DB2 helps you manage the size**
  - REORG AUTOESTSPACE YES
  - RTS tracks the number of overflowed entries



# DB2 10: 64 bit Evolution Virtual Storage Relief

**Scalability:** *Virtual storage constraint is still an important issue for many DB2 customers, until DB2 10*

**DB2 10: 5 to 10 times more threads, up to 20,000**

- Move 80% - 90% above bar
- More concurrent work
- Reduce need to monitor
- Able to consolidate LPARs
- Reduced cost
- Easier to manage
- Easier to grow

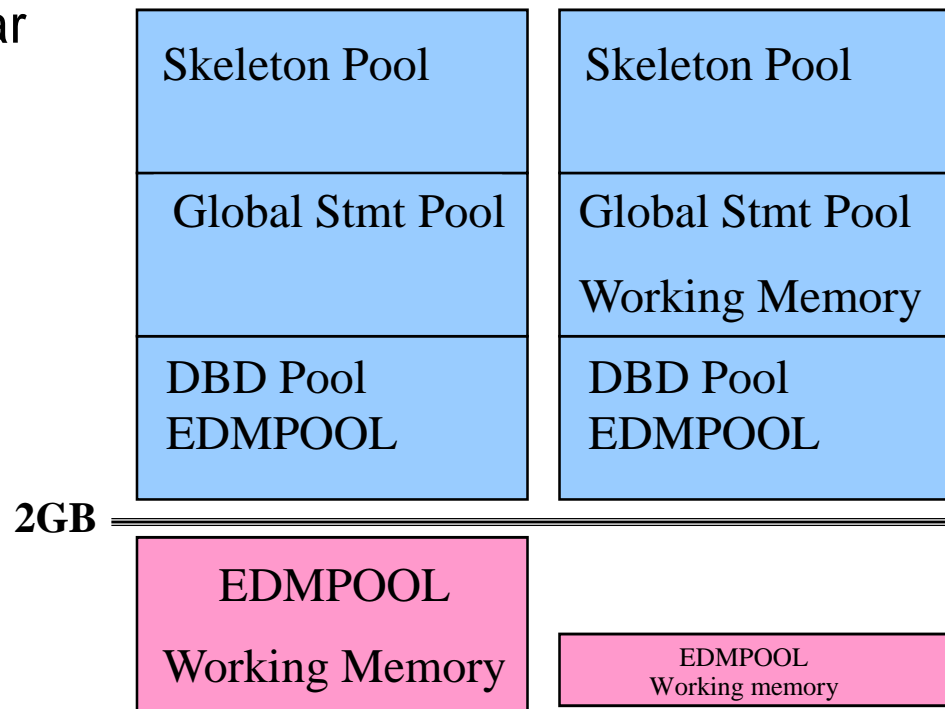

**REBIND is needed for much of the savings.**





# Running a Large Number of Threads

Today

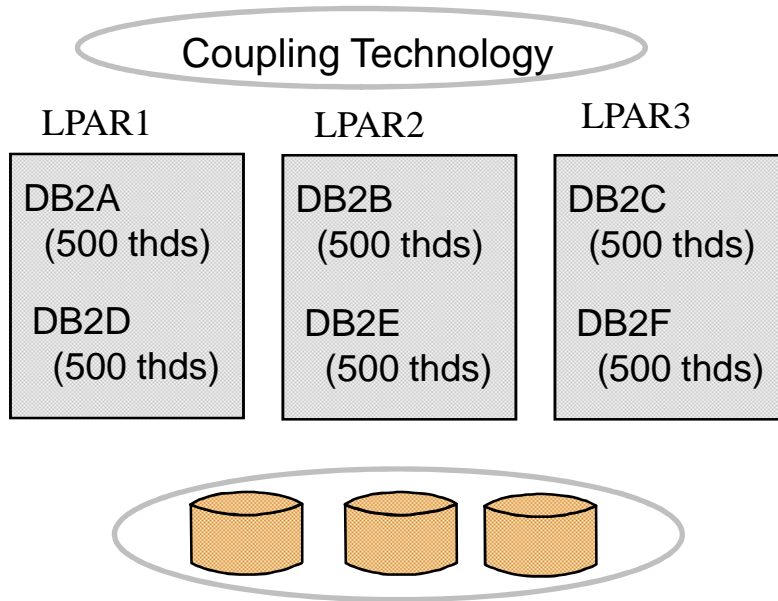

- Data sharing and sysplex allows for efficient scale-out of DB2 images
- Sometimes multiple DB2s / LPAR

DB2 10

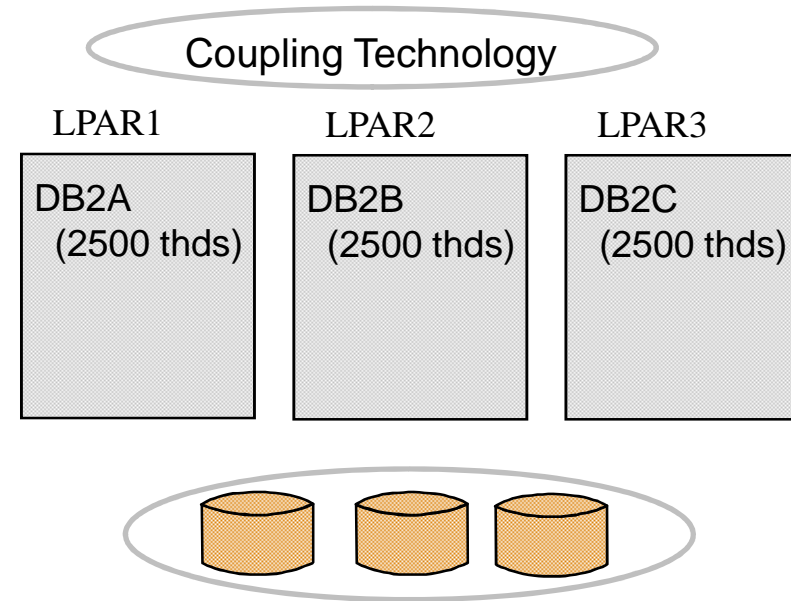

- Easier growth, lower costs, easier management
- More threads per DB2 image
- More efficient use of large n-ways
- Potential for fewer members / LPARs
- Rule of thumb: save ½% CPU for each member reduced, more on memory
- Data sharing and Parallel Sysplex still required for very high availability and scale



## DB2 10: Other System Scaling Improvements

- **Other bottlenecks can emerge in extremely heavy workloads**
  - Several improvements planned to reduce latching and other system serialization contention
  - New option to for readers to avoid waiting for inserters
  - Eliminate UTSERIAL lock contention for utilities
  - Use 64-bit common storage to avoid ECSA constraints
- **Concurrent DDL/BIND/Prepare processes can contend with one another**
  - Restructure parts of DB2 catalog to avoid the contention
- **SPT01 64GB limit can be a constraint, especially if package stability is enabled**
  - Allow many more packages by using LOBs
- **Improved accounting rollup, compress SMF option**
  - Reduced SMF data volume

- 26 ■ **Lower overhead for very large buffer pools**



## DB2 10: Catalog and Directory Improvements

- **Remove links and enable row level locking on key catalog tables**
  - Improved concurrency for BIND, PREPARE, and DDL
  - DSN1CHKR no longer needed in DB2 10 NFM
- **Move long strings such as SQL statements and package binaries to LOBs**
  - Removes max size constraint for SPT01 and others
  - Easier to query SQL statements from catalog
- **Online REORG for all catalog and directory table spaces**
- **Allow SELECT from SYSLGRNX**
- **Easier management: DB2 managed and SMS controlled**



## DB2 10: Data Sharing Improvements

- **ACCESS DATABASE command wildcarding support - V9 PK80925**
- **Sub-group attach (V9 usermod)**
- **BP scan avoidance**
- **Delete data sharing member**
  - Offline utility for “deactivate”, “reactivate”, “destroy”
- **MEMBER CLUSTER support for UTS**
- **DDF Restart Light enhancements: Handle DDF in-doubt URs**
- **Online DDF changes**
- **Auto rebuild CF lock structure on long IRLM waits during restart**
  - Can avoid group-wide shutdowns
- **LRSN spin avoidance for inserts to the same page (e.g. Multi Row Insert)**
- **IFCID 359 for index split**
- **New zparm to force deletion of CF structures on group start (e.g. DR testing)**



## DB2 10: Availability – Online Schema Changes

- **Online schema changes for table spaces, tables and indexes**
  - **PENDING with ALTER and Online REORG instead of DROP/CREATE or REBUILD INDEX**
    - Page size for table spaces and indexes
    - DSSIZE for table spaces
    - SEGSIZE
    - Convert single table segmented into UTS PBG
    - Convert single table simple into UTS PBG
    - Convert classic partitioned table space into UTS PBR
    - Convert UTS PBR to UTS PBG
    - Convert PBG to hash (immediate, but RBDP index)
    - MEMBER CLUSTER
    - Ability to drop pending changes



# Availability – More Online Schema Changes...

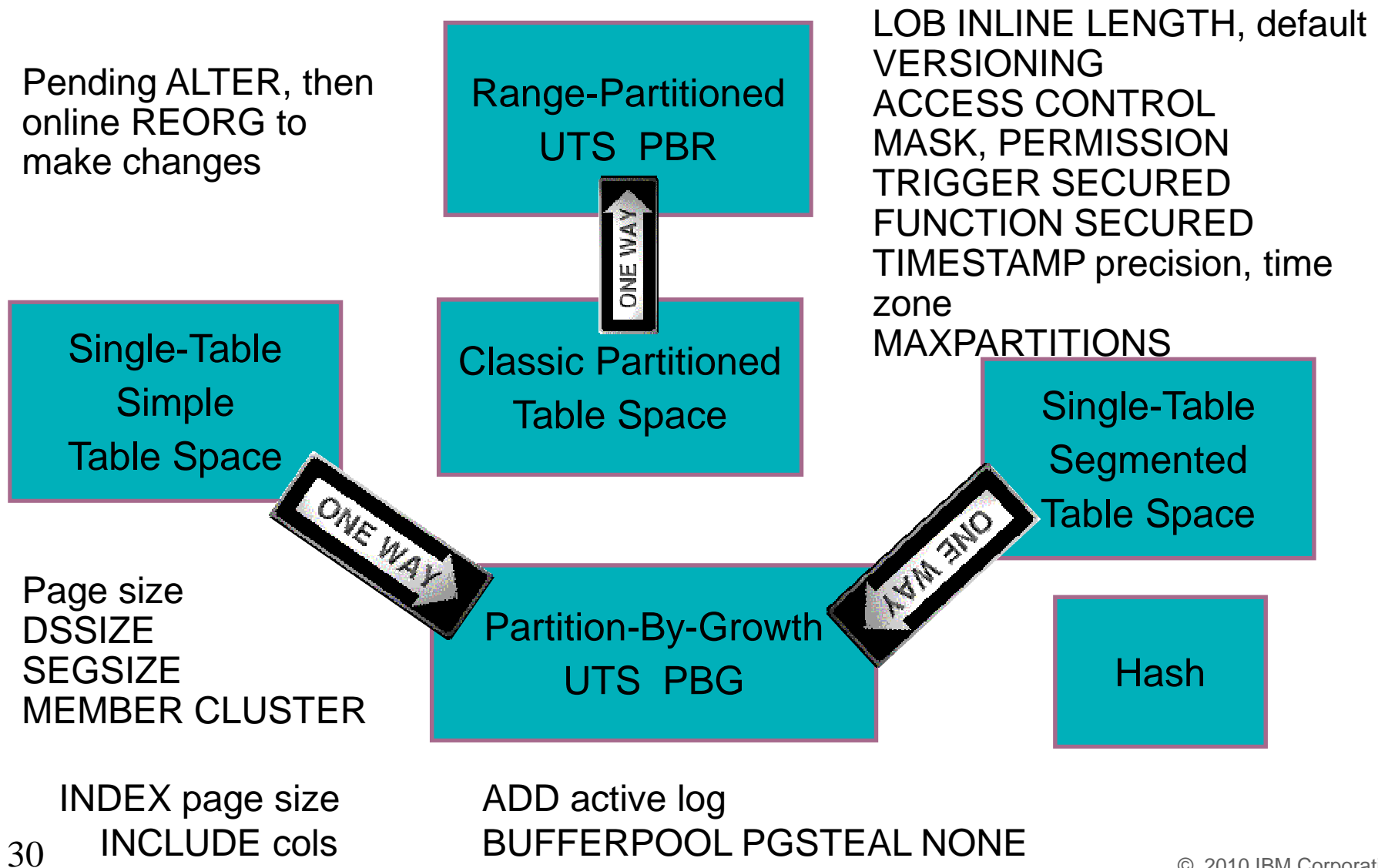



## Other Availability Improvements

- **Access currently committed data**
- **Change DDF location alias names online**
  - New MODIFY DDF ALIAS command
- **Online DDF CDB changes**
  - LOCATIONS, IPNAMES, IPLIST
- **Online add active log**



## DB2 10: Utilities Enhancements – Online REORG

- REORG SHRLEVEL(CHANGE) for LOBs
  
- Online REORG enhancements
  - SHRLEVEL(CHANGE) support for all catalog/directory objects
  - Option to cancel blocking threads
  - Improved availability
    - Update stats after de-drain in UTILTERM phase
  
  - Allow disjoint partition ranges
  - Permit movement of rows between partitions when LOB columns exist
    - Allows REBALANCE and ALTER LIMITKEY even when LOB columns exist
    - Allows DISCARD to delete associated LOB values
  
  - Messages to estimate length of REORG phases and time to completion





## DB2 10: More Utility Improvements

- Support of spanned records for UNLOAD of LOB data
- Autonomic RUNSTATS & table profile
- Improved COPY CHANGELIMIT performance
  - Use RTS instead of SM page scans
- Data set level FlashCopy option
- FlashCopy backups with consistency and no application outage
- FlashCopy backups as input to:
  - RECOVER (fast restore phase)
  - COPYTOCOPY, DSN1COPY
- RECOVER “back to” log point
- REPORT RECOVERY support for system level backups



## DB2 10: Productivity – Doing More With Less!

- **Auto statistics collection**
- **Easier scaling, simpler memory management**
- **Reduce contention, more online processing**
- **Access path stability**
- **Reduced need for REORG**
  - Build compression dictionary on the fly
  - Index list prefetch enhancements
- **Configure IBM UDFs and stored procedures**
- **Allow one SDSNEXIT data set for many subsystems**
- **Monitoring enhanced**
  - Timeout / deadlock diagnostics
  - Identify SQL statements

Name	Monitoring Status	Data Server Status	Critical	Warning	CPU Usage	Disk Space	Memory Usage	Locking	SQL Performance	Connections	Transactions	Logging	Maintenance
Production	3	8											
Web	1	1											
eCommerce	0	0											
Support	1	1											
Retail	0	0											
New York	0	0											
Los Angeles	0	0											
Accounts	2	3											
Marketing	0	4											
Test	0	0											
Development	0	0											

Manual invocation of

- RUNSTATS
- COPY/BACKUP SYSTEM
- QUIESCE
- MODIFY RECOVERY
- REORG



## DB2 10: Autonomics and DBA Productivity...

- **Checkpoint intervals based on both time and # log records**
- **Run 'must complete' backout under pre-emptable SRB**
- **Identify unused packages**
- **SQL Statement level monitoring**
  - Statement ID introduced
  - Trace records & messages extended to include statement ID
  - New trace class for statement detail
    - GetPages, Locks, I/Os, cpu/elapsed time, etc. at statement level
    - Available via IFI for online monitors or via SMF/GTF
- **Exploit z/OS 1.10 WLM service to temporarily boost priority of blocking lock holders**
  - Complements V9 health monitor task which handles latches
- **Manage max threads, connections, idle thread timeout on an application basis**
  - Warning or exceptions issued when threshold is hit
  - Profiles can be set based on userids, packages, IP addresses, member names, ...



## DB2 10: Optimization Stability and Control

**Provide unprecedented level of stability for query performance by stabilizing access paths for**

- Static SQL - Relief from REBIND regressions
- Dynamic SQL
  - Remove the unpredictability of PREPARE
  - Extend Static SQL benefits to Dynamic SQL

### **Support:**

- Versioning
  - “Fallback”
  - “Lockdown”
  - Manual overrides. Hints: easily influence access paths without changing apps
  - Per-statement BIND options
- 
- **Safe query optimization: assess “reliability” of access path choices**
  - **Adaptive algorithms, e.g. RID pool overflow to workfiles**



## DB2 10: Business Security and Compliance

- Protect sensitive data from privileged users & improve productivity
  - SECADM & DBADM without data access
  - Usability: DBADM for all DB
  - Revoke without cascade
- Separate authorities to perform security related tasks, e.g. security administrator, EXPLAIN, performance monitoring and management
- Audit privileged users
- Row and column access control
  - Allow masking of value
  - Restrict user access to individual cells



Use disk encryption



## DB2 10: Security Benefits

- More flexible authorization
  - Separation of duties
  - Do job without access to data
  - Policies for audit
  - Simpler control
  - Tighter security
  - Avoid cascade delete
  - Avoid views and application security logic
  - Allow more tools
  - Evolve security policies
  - Easier to manage security policy
- Improved productivity & tighter security



Use disk encryption



## DB2 10: New Application Features

- **Data versioning, temporal data**
- **pureXML enhancements**
- **Large object improvements**
  - Allow non-NULL default values for inline LOBs
  - Loading and unloading tables with LOBs
    - LOBs in input/output files with other non-LOB data
- **Currently committed locking semantics**
- **Implicit casting or loose typing**
- **Timestamp with timezone**
- **Greater timestamp precision – to picoseconds**
- **Moving Sum, Moving Average**



## Versioned Data or Temporal Data

- **Table-level specification to control data management based upon time**
- **Two notions of time:**
  - System time: notes the occurrence of a data base change
    - “row xyz was deleted at 10:05 pm”
    - Query at current or any prior period of time
    - Useful for auditing, compliance
  - Business time: notes the occurrence of a business event
    - “customer xyz’s service contract was modified on March 23”
    - Query at current or any prior/future period of time
    - Useful for tracking of business events over time, application logic greatly simplified
- **New syntax in FROM clause to specify a time criteria for selecting historical data**





# Current and History

Current SQL Application

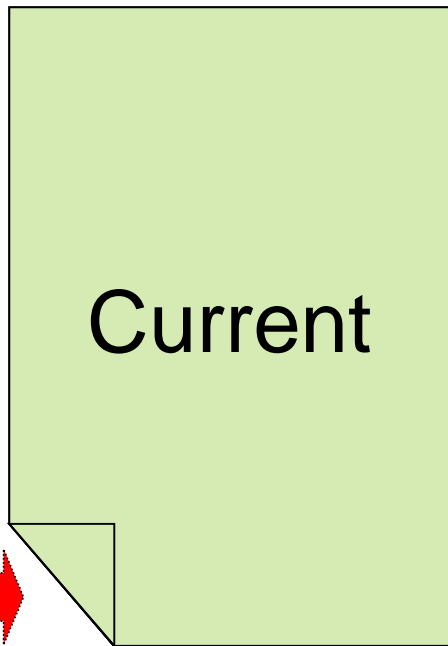
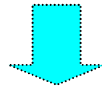

Auditing SQL Application  
Using ASOF

History  
Generation



Transparent/automatic  
Access to satisfy ASOF  
Queries





## Temporal UPDATE example (business time)

Simple table definition (Policy#, start, end, coverage)

Table has 1 row of (123,'01/01/2001', '12/31/2001', 1000)

```
UPDATE policy p
  FOR BUSINESS_TIME FROM DATE('03/01/2001') TO DATE('03/31/2001')
  SET coverage = 2000;
```

Result of the update statement is 3 rows:

```
(123,'01/01/2001','03/01/2001',1000)
(123,'03/01/2001','03/31/2001',2000)
(123,'03/31/2001','12/31/2001',1000)
```



## DB2 10: More New Application Features

- **SQL stored procedure enhancements**
  - SQL PL in Scalar UDFs & XML support
- **64-bit ODBC – also DB2 9 PK83072**
- **EXTENDED INDICATOR VARIABLES** to indicate value not supplied or default
- **DRDA support of Unicode for system code points**
- **CURRENT EXPLAIN MODE** special register
- **Allow caching of dynamic SQL statements with literals**
- **Data-dependent paging**
  - When only a specific part of the result set is needed
  - Efficient access to desired portions of result set, based upon current position



## DB2 10: Query Enhancements

- **CPU time reductions for queries, batch, & transactions**
- **SQL enhancements: Moving Sum, Moving Average, temporal, timestamp, implicit cast, SQL PL, ...**
- **pureXML improvements**
- **Access improvements: Index include columns, hash, index list prefetch, workfile spanned records, ...**
- **Optimization techniques**
  - Remove parallelism restrictions and more even parallel distribution
    - increased zIIP use
  - In-memory techniques for faster query performance
  - Access path stability and control
- **Analysis: instrumentation, Data Studio & Optim Query Tuner**
- **Advanced query acceleration techniques**
  - IBM Smart Analytics Optimizer



## pureXML Performance and Usability Improvements

- XML schema validation in the engine for improved usability and performance
- Binary XML exchange format improves performance
- XML multi-versioning for more robust XML queries
- Allow easy update of sub-parts of XML document
- Stored proc, UDF, Trigger enhanced support
- XML index matching with date/timestamp
- CHECK utility checks XML



# *DB2 10 for z/OS Migration paths available*





## DB2 10 for z/OS: Skip-Level Migration

You may move from V8 to DB2 10,  
**but** just because you can, doesn't mean you always should...

Key considerations:

- Risk/reward analysis

- What's the risk? Tolerance level?
- How will you do it? What's your mitigation plan? Are ISVs ready?
- What workloads do you need to test and can you test them properly?
- Am I missing out on DB2 9 value in the meantime?

- Migration cost savings is not 2x versus two migrations

- Migration considerations for two releases still apply
- Larger migration project, longer migration timeline
- Applications and ISVs may not be ready



Data sharing mixed release coexistence fully supported  
V8/10 or V9/10



## Migration and Fallback Paths when migrating (V9 ==> V10)

- With DB2 10, you can always drop back to the previous stage
- Cannot fallback to DB2 9 after entry to DB2 10 (ENFM9), but can return to DB2 10 (CM9\*)

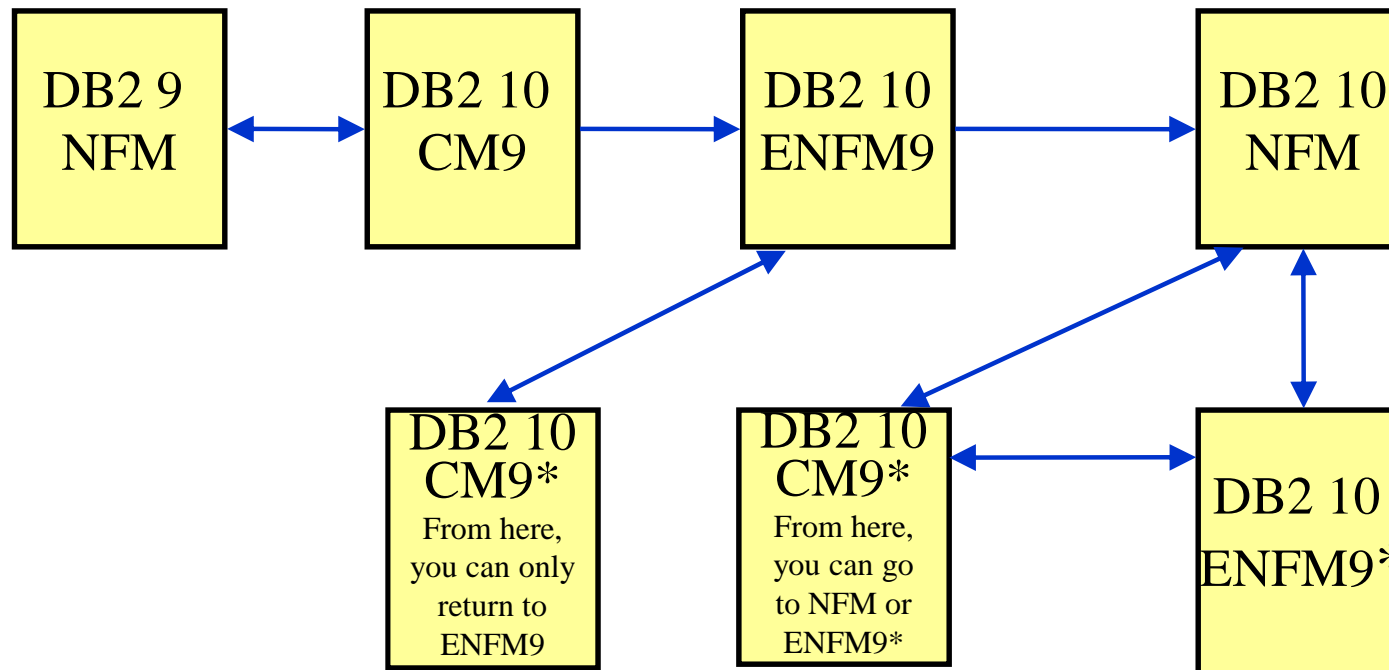





## Migration and Fallback Paths when migrating (V8 ==> V10)

- With DB2 10, you can always drop back to the previous stage
- Cannot fallback to DB2 V8 after entry to DB2 10 (ENFM8), but can return to DB2 10 (CM8\*)

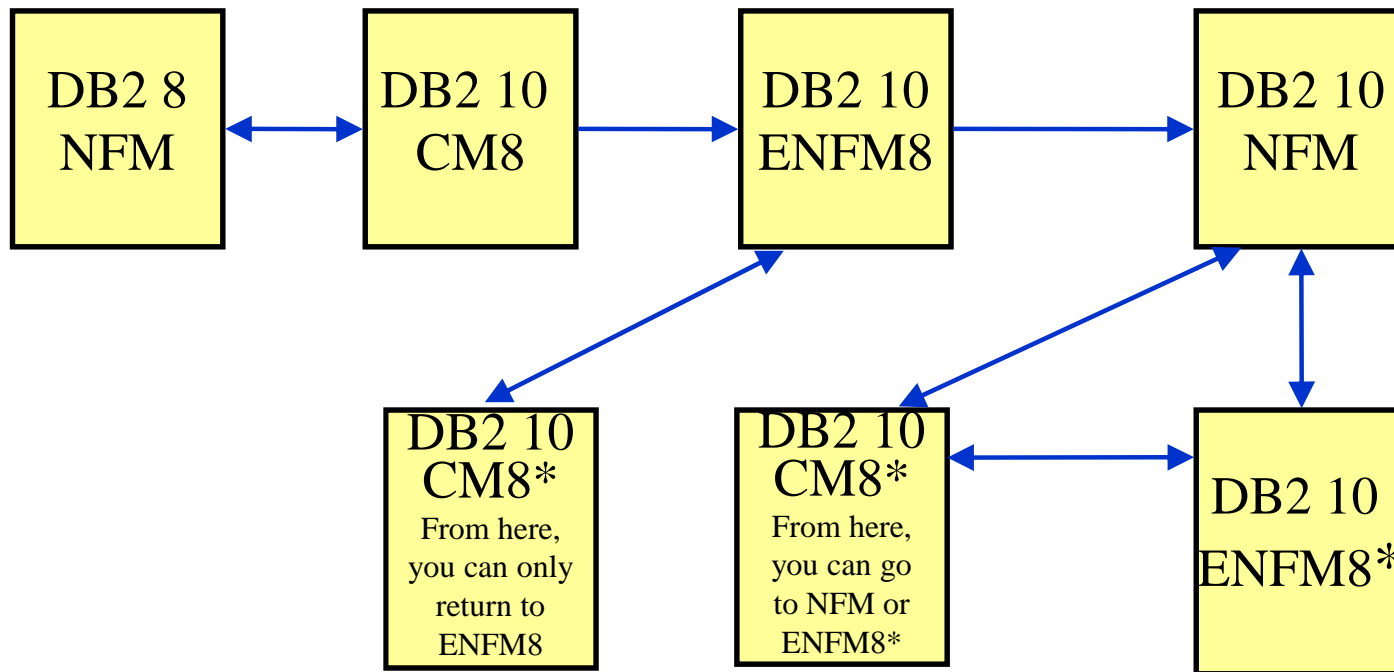



## Things to be considered when “skipping” past V9?

- **DB2 9 for z/OS education**
  - Migration Planning workshop materials
  - Redbooks
  - Transition class
- **Check for DB2 9 release incompatibilities**
- **Familiarity with the new modes**
  - CM\*, ENFM\* introduced in V9
- **Deprecated items**
- **Performance benefits**
- **Storage changes**
- **Utilities updates**
- **Key enhancements e.g. pureXML**





## Migration considerations to **REMEMBER**

- A V8 system started migration to V10, can only fallback to V8.
- A V8 system started the migration to V10, then performed fallback to V8, can not then migrate to V9.
- A V8 system migrating to V10, can not use V9 new functions until V10 NFM is reached.
- A data sharing group that started migrating from V8 to V10 can not have any V9 members.
- A V9 system that has started the migration to V10 can only fallback to V9.
- A data sharing group that started migration from V9 NFM to V10 can not have any V8 members.



# *DB2 10 for z/OS*

## *Hardware & Software Prerequisites*



## Prerequisites – Hardware & Operating System

- **Processor requirements:**

- zEnterprise, z10, z9, z990 and z890 processors supporting z/Architecture
  - **z800 or z900 processors NOT supported**
- DB2 10 for z/OS will probably require increased real storage for a workload compared to DB2 9 for z/OS

- **Software Requirements:**

- z/OS V1.10 Base Services (5694-A01) at minimum
- DFSMS V1 R10 – DB2 Catalog now SMS managed
- Language Environment Base Services
- z/OS Version 1 Release 10 Security Server (RACF)
- IRLM Version 2 Release 3 (Shipped with DB2 10 for z/OS)
- z/OS Unicode Services and appropriate conversion definitions are required.





# *DB2 10 for z/OS*

## *Pre-migration planning*



## Important preparation

- **PDSE requirement**

```
Enter "/" to select action
```

	Dsorg	Recfm	Lrecl	Blksz
SYS2.DB2.V10.SDSNLINK	PO	U	0	32760
SYS2.DB2.V10.SDSNLOAD	PO-E	U	0	32760
SYS2.DB2.V10.SDSNLOD2	PO-E	U	0	32760
SYS2.DB2.V10.SDSNMACS	PO	FB	80	3120

- **Migrate only from a system with an expanded BSDS (DSNJCNVB)**
- **and packages V5 or before → REBIND**
- **Old plans Plans containing DBRMs → packages (PK62876 (V9), PK85833 (V9), PK79925 (V8), PM01821 (All))**
- **ACQUIRE(ALLOCATE) → ACQUIRE(USE)**
- **Old Plan table formats → DB2 V8 or 9 format (59 columns)**



## Items deprecated in earlier versions – NOW eliminated

- Private protocol → DRDA (new help in DSNTDP2DP, PK64045)
- XML Extender → XML type
- DB2 MQ XML UDFs and stored procedures → XML functions
- DB2 Management Clients feature → IBM Data Studio application & administration services
- BookManager use for DB2 publications → Info Center, pdf
- The DB2 Customization Center, DB2's plugin for the z/OS msys for setup installation initiative, is discontinued in DB2 Version 10 → install panels





## Requirements for Dependent Functions

- **System level Point-in-Time (PIT) Backup and Recovery**
  - DFSMShsm, DFSMSdss
  - FlashCopy Version 1
  - FlashCopy Version 2 (required for object-level recovery from system-level backup and FlashCopy backups)
  - Remove restriction for object recovery from a System-Level Backup requires z/OS Version 1 Release 11
- **Extended Address Volumes (EAV)**
  - Large sequential datasets require z/OS Version 1 Release 11
- **Encryption and decryption**
  - Built-in functions require z/OS Integrated Cryptographic Service Facility (ICSF).
  - **DRDA Data Stream Encryption** can optionally use ICSF.
- **Group Bufferpool (GBP) Batching**
  - See the latest Coupling Facility (CF) level recommended for your processor at: <http://www.ibm.com/systems/z/advantages/ps0/cftable.html>



## Overview of the information center (IC)

- **BookManager format is not supported for the DB2 V10 for z/OS library.**
  - We offer an on-line information center that contains the information for supported versions.
  - As always, we support and provide PDF versions of our information.
  - We also offer an installable IC that you can run on your local system or intranet server. For ordering information, see:  
<http://publib.boulder.ibm.com/infocenter/dzichelp/v2r2/topic/com.ibm.dzic.doc/installabledzic.htm>
- **The IC is the IBM strategic direction for delivering information.**
- **The IC is a browser-based information portal—an industry-wide trend.**
- **The DB2 for z/OS IC has been available since V8 GA. Our IC is one of IBM's top visited ICs based on total number of hits!**
- **Current information for V8 and V9 is available at:**  
<http://publib.boulder.ibm.com/infocenter/imzic/>



## For more information on DB2 10

<http://www.ibm.com/software/data/db2/zos/db2-10/>

<ftp://public.dhe.ibm.com/software/data/db2/zos/presentations/v10-new-function/>

Name	Size	Type	Modified
availability-idug-na-2010-roberts.pdf	700 KB	Adobe Acrobat Doc...	5/28/2010 1:02 PM
db2-10-questions-answered.pdf	37.1 KB	Adobe Acrobat Doc...	5/28/2010 3:02 PM
db2-10-webcast-2010-miller.pdf	1.35 MB	Adobe Acrobat Doc...	5/28/2010 3:02 PM
dba-idug-na-2010-miller.pdf	934 KB	Adobe Acrobat Doc...	5/28/2010 1:02 PM
optimizer-idug-na-2010-purcell.pdf	253 KB	Adobe Acrobat Doc...	5/28/2010 1:02 PM
optimizer-iod-2010-purcell.pdf	643 KB	Adobe Acrobat Doc...	5/28/2010 1:02 PM
performance-preview-idug-na-2010-hoshikawa.pdf	413 KB	Adobe Acrobat Doc...	5/28/2010 1:02 PM
SAP-iod-2010-schuetzner.pdf	303 KB	Adobe Acrobat Doc...	5/28/2010 1:02 PM
security-iod-2010-pickel.pdf	845 KB	Adobe Acrobat Doc...	5/28/2010 1:02 PM
xml-iod-2010-zhang.pdf	736 KB	Adobe Acrobat Doc...	5/28/2010 1:02 PM

See the web for presentations from recent conferences. Topics include overview, optimization, performance, advantages for SAP, security and XML.



Questions?





# DB2 10 for z/OS Technical Overview

**Don Grossweiler**  
*DB2 for z/OS Development*

ddg@us.ibm.com

