

# Powering Your Performance



## Serialization / Track & Trace for Pharmaceuticals

IBM: Supply Chain Visibility and Optimization for a smarter planet

La Gaude, 16<sup>th</sup> September 2009

# Agenda

- **Bayer Technology Services**
- **Introduction Track & Trace**
- **Legal Requirements worldwide**
- **Realization in the packaging lines**
- **Realization of IT**
- **Summary**

# Bayer Technology Services – a Bayer Group Company

## Holding Company



Ba



### Bayer Technology Services

Turnover worldwide(\*) 420 EUR mill.

Employees worldwide(\*\*) 2,600

(\*)2008 (\*\*)Dec 31, 2008

#### Client industries

- Health Care
- Crop Science
- Material Science/Polymers
- Chemicals

Center



## Business Areas

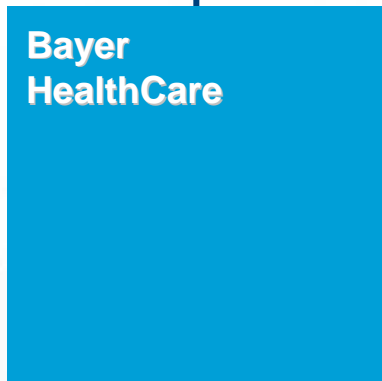

Offers services on external market

## Service Areas

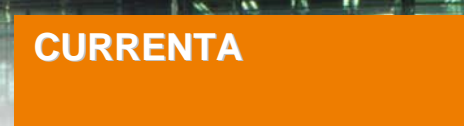

# Bayer Technology Services Activities for 2D-Matrix Project

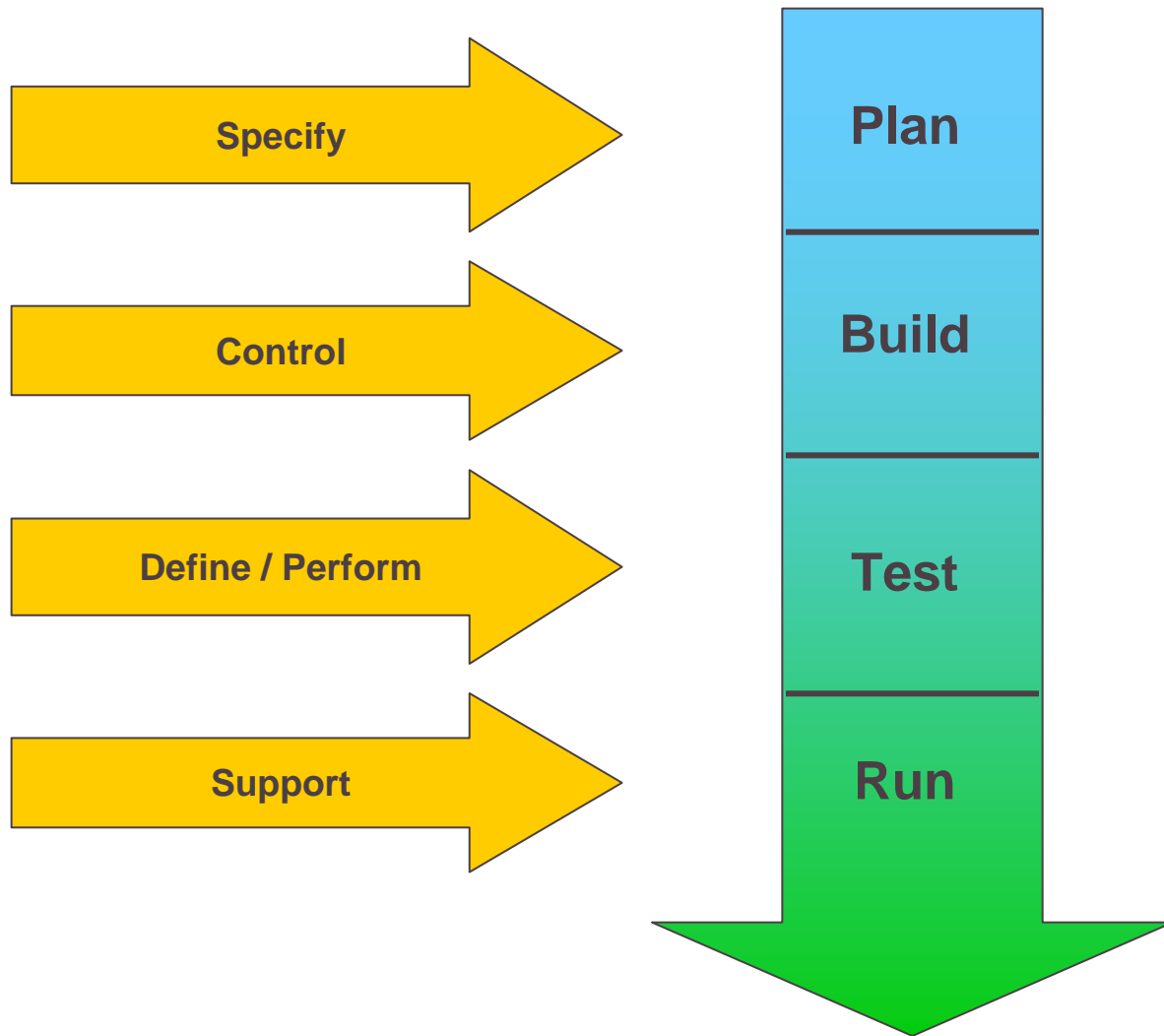

# Agenda

- **Bayer Technology Services**
- **Introduction Track & Trace**
- **Legal Requirements worldwide**
- **Realization in the packaging lines**
- **Realization of IT**
- **Summary**

# Motivation for Serialization on Packaging level

## Securing & Optimizing the Supply Chain

Patient-**Safety** – Anti Counterfeiting



Asset Management and Optimization



Focused **Re-Calls**



## Legal Requirements

Simple & secure Reimbursement → Costs reduction  
-10% for pharmaceuticals (Source: Turkish Ministry of Health)



# Track & Trace in the Supply-Chain

## What does it mean ?

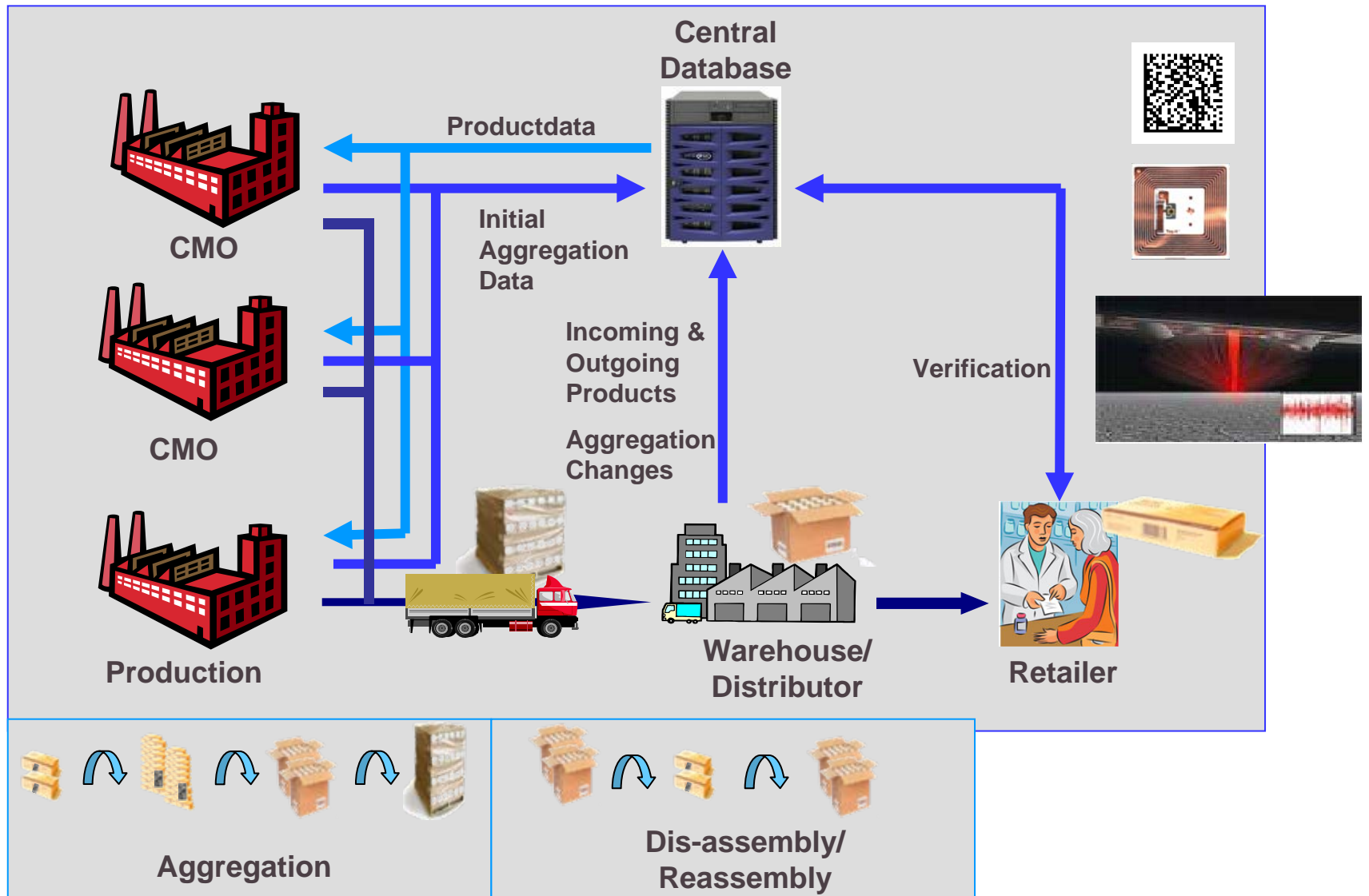

# Authentication Technologies suitable for Track & Trace

- 2D Matrix

- Coding of serial numbers into a 2D Matrix Code
- Cost efficient,
- Standard Equipment available



- RFID

- Serialization based on RFID Chip capabilities
- Encryption possible

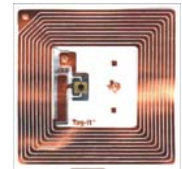

- ProteXXion

- Authentication based on item unique surface structures
- Extremely high inherent security

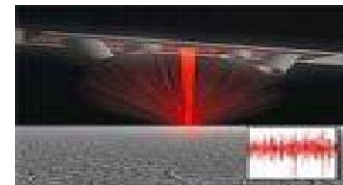



# Agenda

- **Bayer Technology Services**
- **Introduction Track & Trace**
- **Legal Requirements worldwide**
- **Realization in the packaging lines**
- **Realization of IT**
- **Summary**

# Countries requiring Track & Trace

## Defined Track & Trace regulations:



Serialization on item level (Oct. 2009) with aggregation (Jun. 2010) based on 2D Matrix



Serialization on item level with aggregation (Jan. 2010).  
Technology & details currently unknown.



Implementation of a full track & trace system (ePedigree).  
Technology unclear. Implementation probably in 2015 & in 2016

## Planned Track & Trace regulations:



Track & Trace pilot planned using RFID technology in 2010



Pilot (RFID vs. 2DMC) planned in 2010.

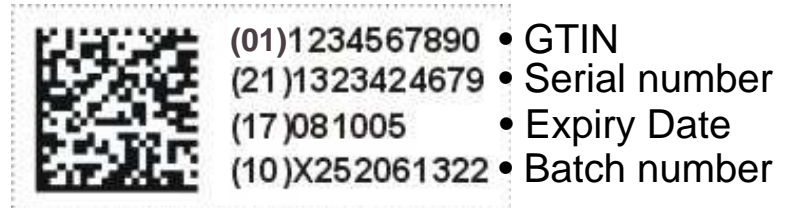

# Countries requiring Product Coding

## Traceability w.o. Serialization:



Traceability on batch level (Jan. 2011) with 2D Matrix

## Defined Serialization regulations:



Security labels (like Bolini) vs. EFPIA compliant solution.  
EFPIA compliant pilot planned.



FDAAA: Serialization of prescription drugs on item level  
Technology & timelines unclear.



Serialization on item level with 2D Matrix.  
Pilot ongoing in Sweden.

# Serialization in Pharma Supply-Chain

EFPIA approach (w.o. Track & Trace)

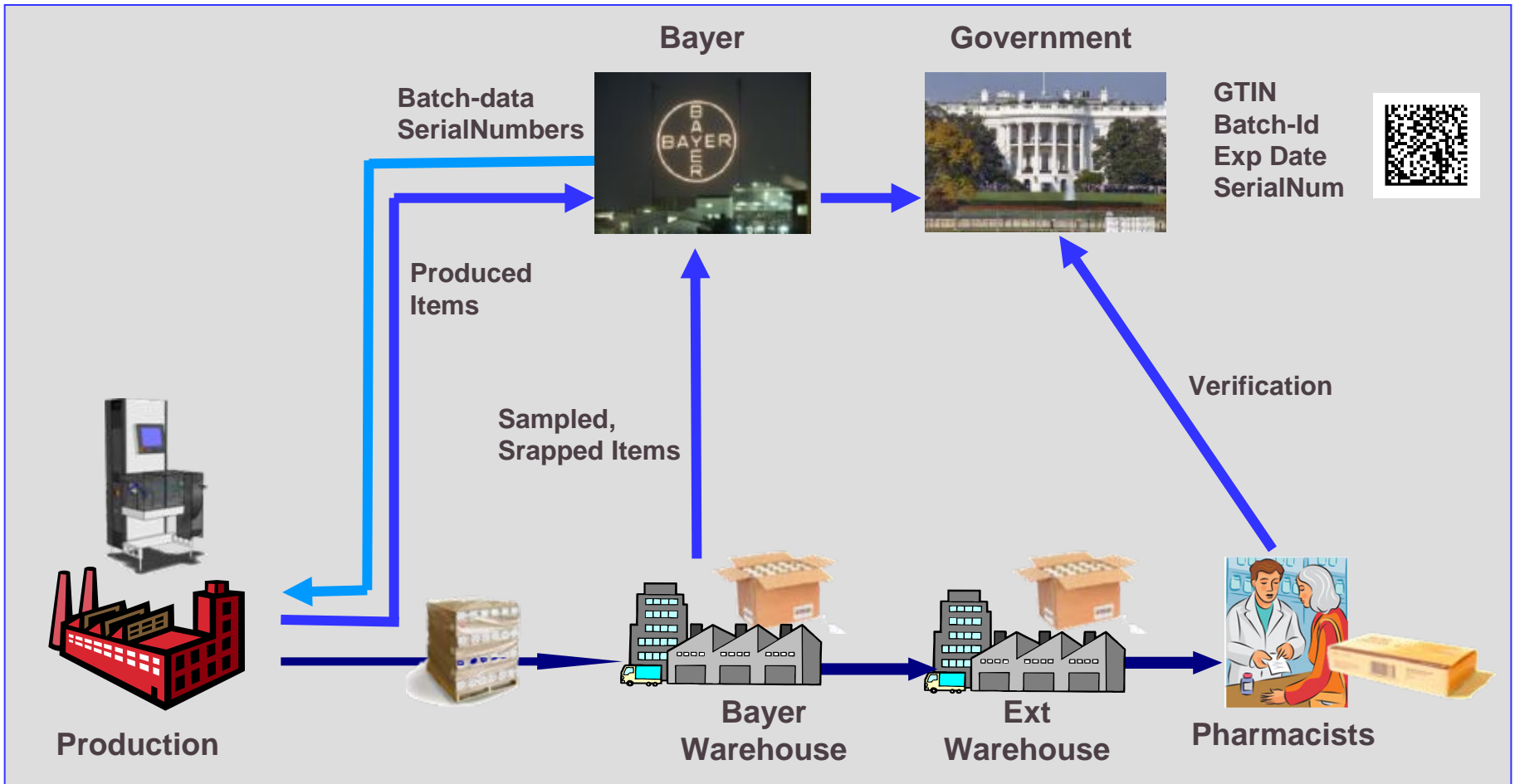

# Serialization in Pharma Supply-Chain

w. Track & Trace

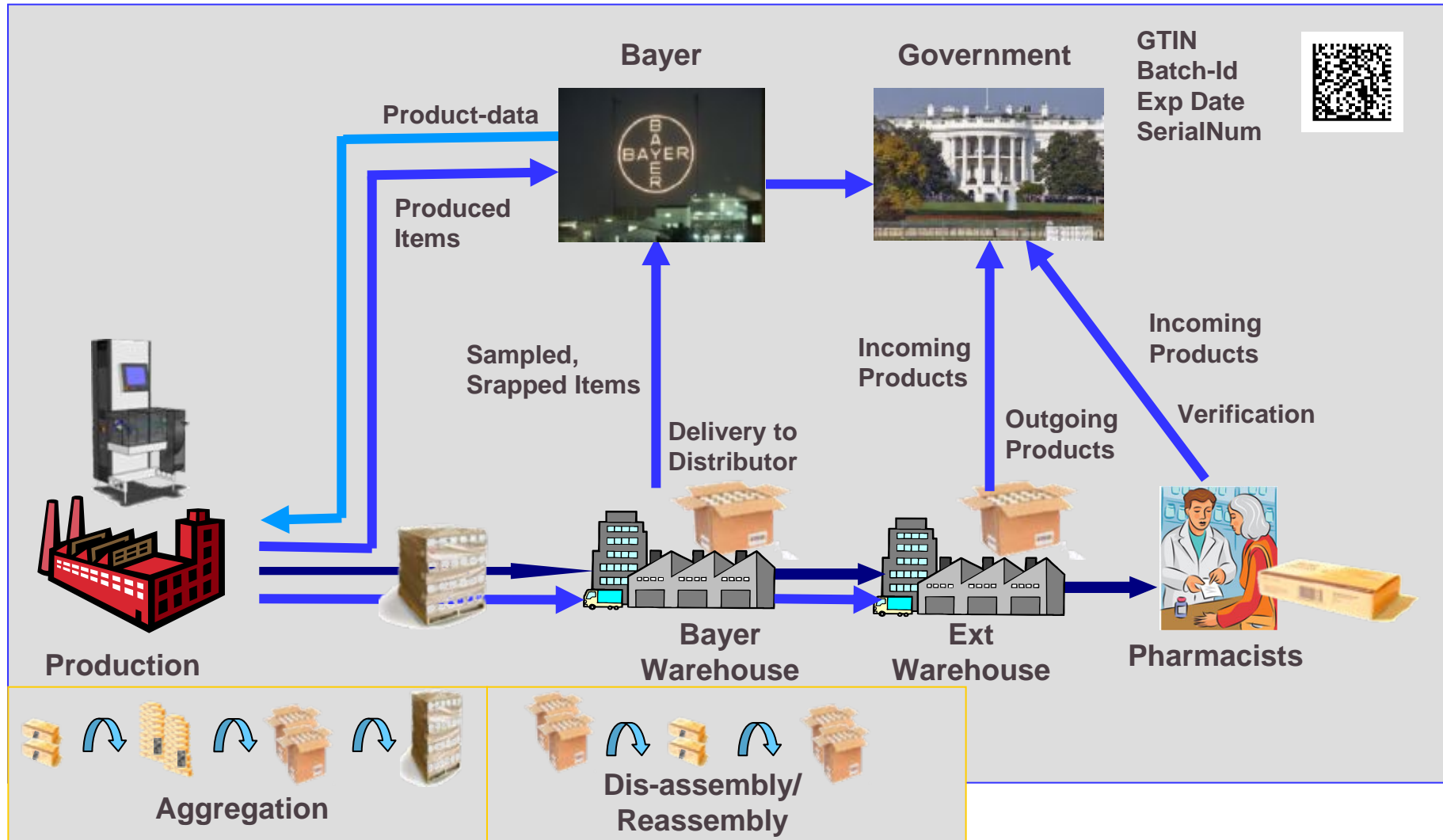

# Agenda

- **Bayer Technology Services**
- **Introduction Track & Trace**
- **Legal Requirements worldwide**
- **Realization in the packaging lines**
- **Realization of IT**
- **Summary**

# Options for Realization

- **Offline** Printing on unfolded Packages

- The unfolded packages become printed before packaging

- Advantages

- Simplified print on flat surface
- Line performance has no impact on print
- One printer can serve multiple lines

- **Inline** Printing in the Line

- The folding boxes are printed in the packaging line

- Advantages

- Reduced effort
- Efficiency – print as many boxes as you need
- Flexibility: Packaging & Printing as a single step

# Selection criterias for the solution

- Performance (up to 400 Packages/ Minute)
- Print Quality (ISO 15415 Grade C)
- Flexible integration into legacy lines
- Reliability & Availability
  - Limited reduction of Output
  - Robustness
- Operational Expenses
  - User friendly configuration and adjustment
  - Limited requirements on operator skills
- Required Investment



# Realization in the packaging lines (Single Unit)

- Inkjet based printing
- Autonomous Print & Verification Station
- Fully integrable
- Operates integrated or stand-alone

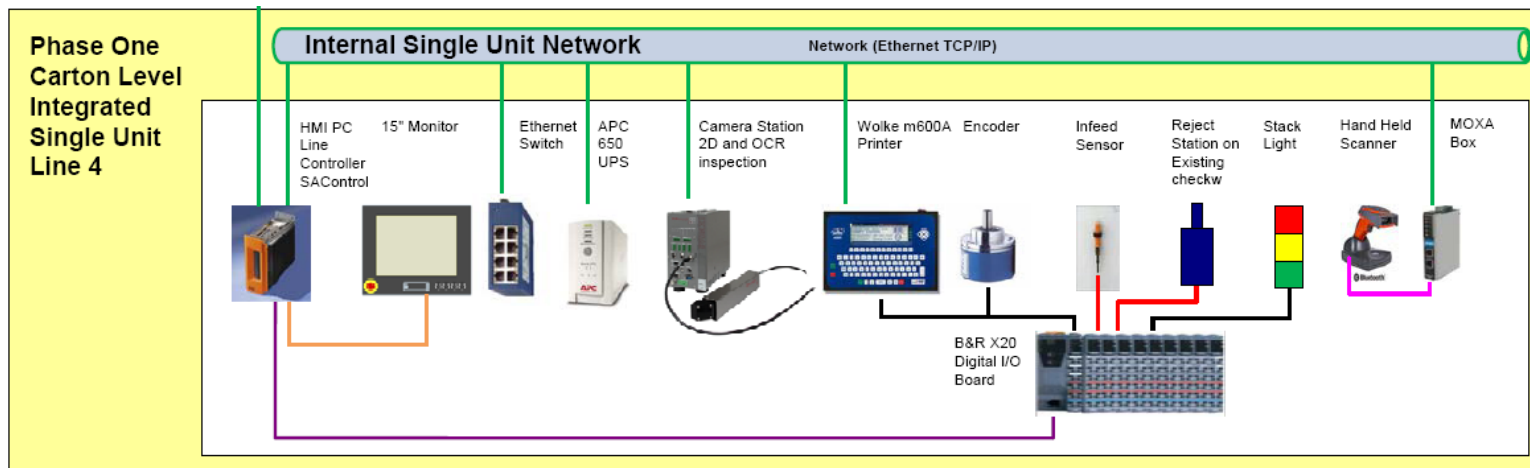

Source:  
Seidenader

# Agenda

- **Bayer Technology Services**
- **Introduction Track & Trace**
- **Legal Requirements worldwide**
- **Realization in the packaging lines**
- **Realization of IT**
- **Summary**

# BHC Blueprint Solution – System Architecture France

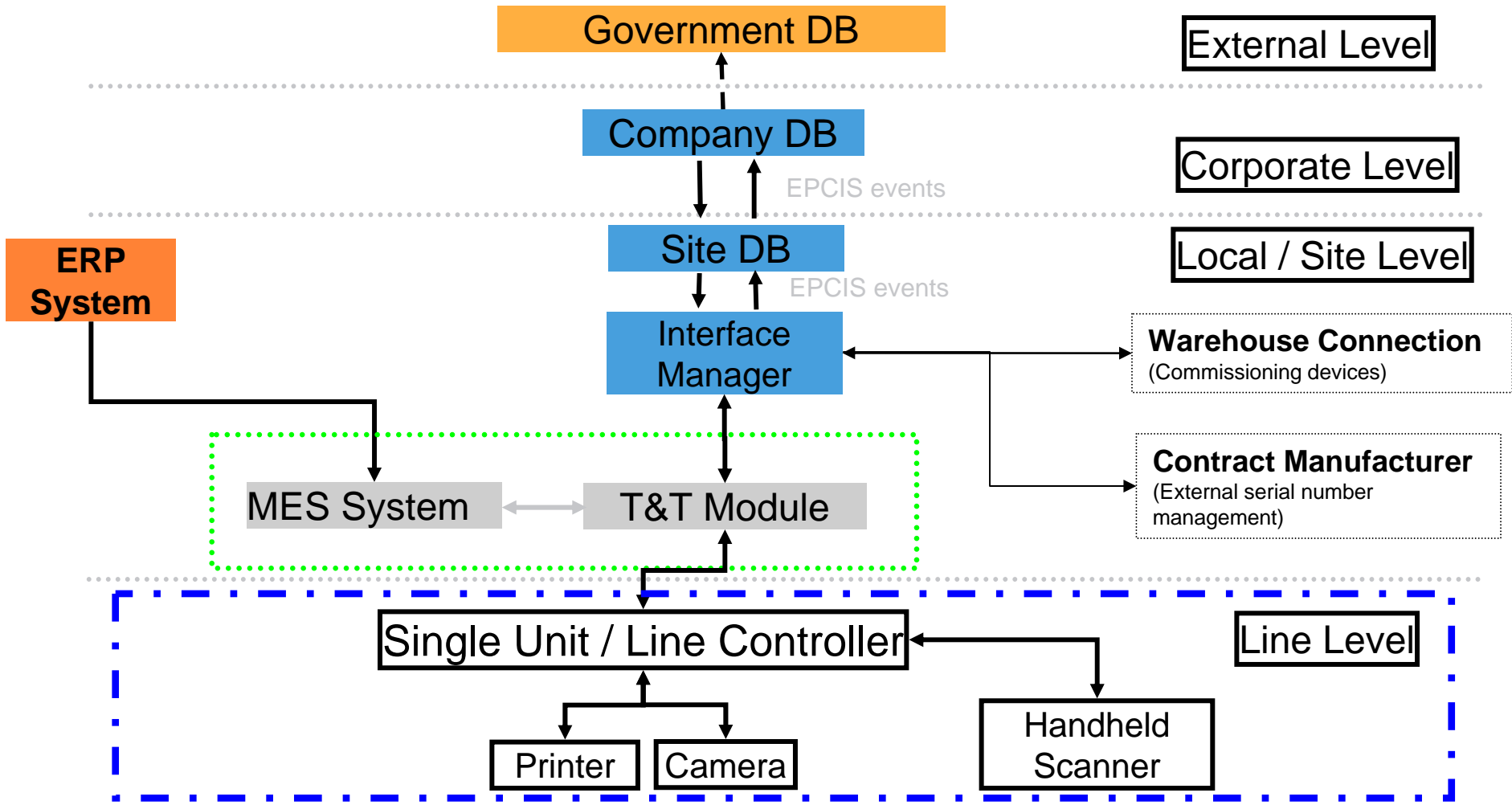

# Serialization IT-Architecture Overview

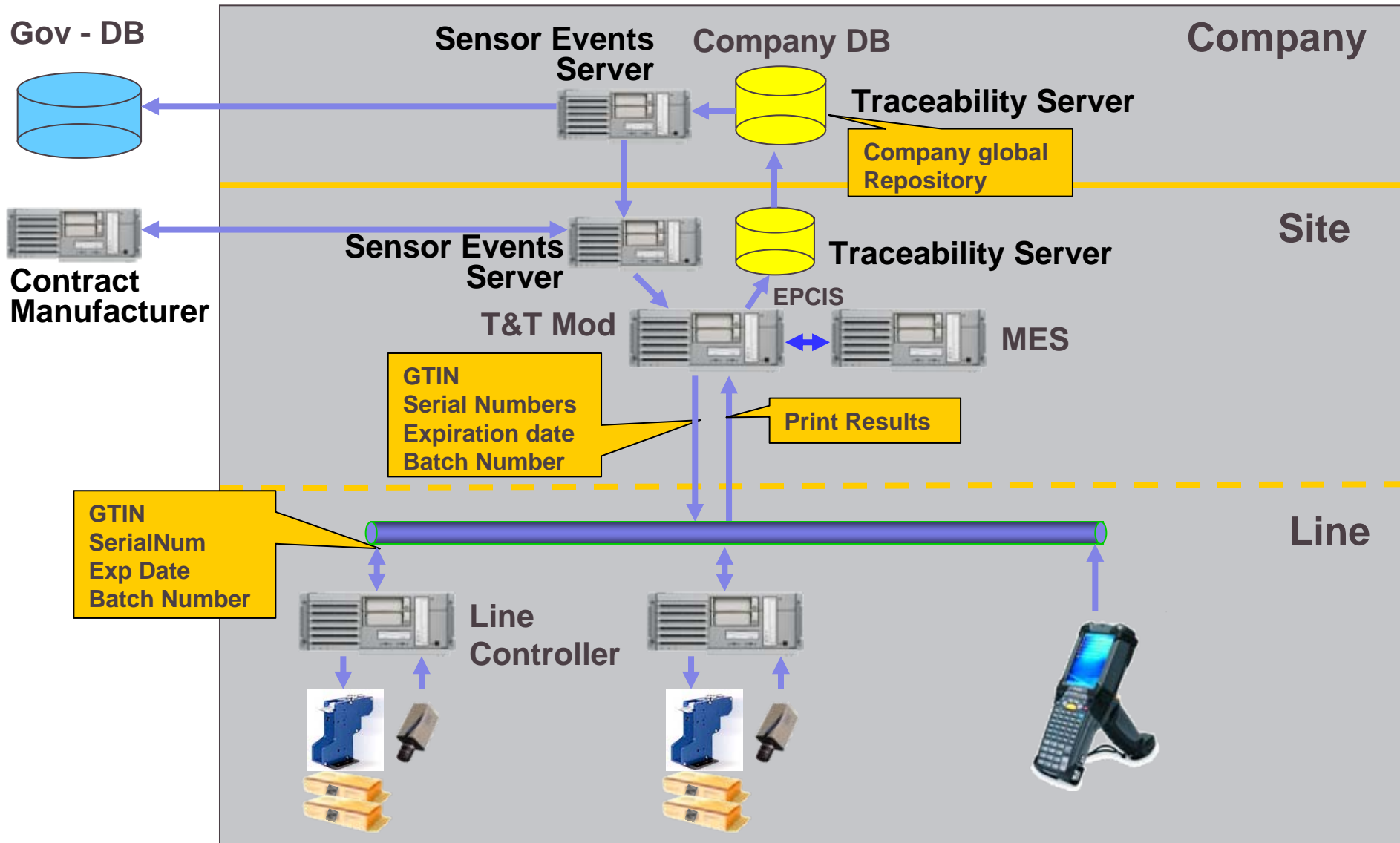

# Communication based on EPCIS-Events (Electronic Product Code Information Services)

Action

Event

Target

Generation



Object Event

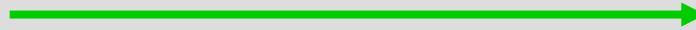

Company Database



Aggregation



Aggregation Event

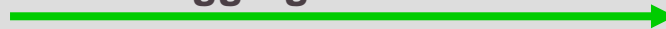

Stock

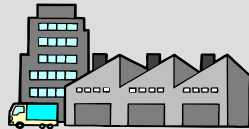

Object Event

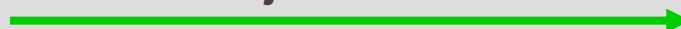

Delivery



Transaction Event

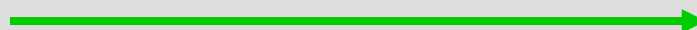

Partner Database



Registration



Quantity Event

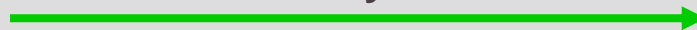

# Agenda

- **Bayer Technology Services**
- **Introduction Track & Trace**
- **Legal Requirements worldwide**
- **Realization in the packaging lines**
- **Realization of IT**
- **Summary**

# Challenges and Experiences

- Close investigation of workflows and processes required
- Integration of different stake holders
  - Bayer Internally: Engineering, production, Information Technology, Quality-Management, Packaging department etc
  - Externally: Supplier, Contract Manufacturer (CMO's), Warehouses, Distributors
- Challenges caused by legacy packaging lines
  - High speed lines require high speed equipment
    - Printer, Camera
    - Precise guiding of packages along the printer
  - Limited space in the lines
  - Inline print technology quite advanced and not familiar to Bayer (steep learning curve)
  - Packaging material must meet additional requirements

# Experiences

- 2D Matrix is a viable technology for Serialization
- Printing technology improves significantly these days
  - Performance, print quality
  - Optimized Handling in the aggregation process seen possible



# Powering Your Performance



**INNOVATION**

**ENGINEERING**

**OPTIMIZATION**

[info@bayertechnology.com](mailto:info@bayertechnology.com)  
[www.bayertechnology.com](http://www.bayertechnology.com)