

SANworks by Compaq

Data Replication Manager HSG80 ACS Version 8.6-4P Configuration Guide

Part Number: AA-RPHZD-TE

Fourth Edition (March 2002)

Product Version: ACS Version 8.6-4P

SANworks[™] Data Replication Manager by Compaq provides a disaster-tolerant solution for secure data storage through the use of hardware redundancy across several sites. Multiple heterogeneous servers can be connected to one or more shared storage subsystems. This document provides instructions for configuring a Data Replication Manager solution and verifying the validity of the configuration.

COMPAQ

© 2002 Compaq Information Technologies Group, L.P.

Compaq, the Compaq logo, SANworks, StorageWorks, Tru64, and OpenVMS are trademarks of Compaq Information Technologies Group, L.P. in the U.S. and/or other countries.

Microsoft, MS-DOS, Windows, and Windows NT are trademarks of Microsoft Corporation in the U.S. and/or other countries.

UNIX is a trademark of The Open Group in the U.S. and/or other countries.

All other product names mentioned herein may be trademarks of their respective companies.

Confidential computer software. Valid license from Compaq required for possession, use or copying. Consistent with FAR 12.211 and 12.212, Commercial Computer Software, Computer Software Documentation, and Technical Data for Commercial Items are licensed to the U.S. Government under vendor's standard commercial license.

Compaq shall not be liable for technical or editorial errors or omissions contained herein. The information is provided "as is" without warranty of any kind and is subject to change without notice. The warranties for Compaq products are set forth in the express limited warranty statements accompanying such products. Nothing herein should be construed as constituting an additional warranty.

Compaq service tool software, including associated documentation, is the property of and contains confidential technology of Compaq Computer Corporation or its affiliates. Service customer is hereby licensed to use the software only for activities directly relating to the delivery of, and only during the term of, the applicable services delivered by Compaq or its authorized service provider. Customer may not modify or reverse engineer, remove, or transfer the software or make the software or any resultant diagnosis or system management data available to other parties without Compaq's or its authorized service provider's consent. Upon termination of the services, customer will, at Compaq's or its service provider's option, destroy or return the software and associated documentation in its possession.

Printed in the U.S.A.

Data Replication Manager HSG80 ACS Version 8.6-4P Configuration Guide
Fourth Edition (March 2002)
Part Number: AA-RPHZD-TE

Contents

About this Guide

What's New	xv
Intended Audience	xvi
Related Documentation	xvi
Document Conventions	xix
Symbols in Text	xix
Symbols on Equipment	xx
Rack Stability	xxi
Getting Help	xxi
Compaq Technical Support	xxi
Compaq Website	xxii
Compaq Authorized Reseller	xxii

1 Introduction to Data Replication Manager

Data Replication Manager Overview	1-2
Heterogeneous Storage Area Networks	1-2
Required Hardware Components	1-3
Rack Components	1-4
ESA12000 Storage Rack	1-4
EMA12000 Modular Storage Rack	1-6
Fibre Channel Switches	1-9
Gigabit Interface Converters (GBICs)	1-9
Power Distribution Unit (PDU)	1-10
Fully-Redundant Power (Optional)	1-11
Host Bus Adapters	1-11
Hardware Configurations	1-12
Software Components	1-14
Array Controller Software	1-15
Secure Path	1-15
StorageWorks Command Console (Optional)	1-15

Supported Software Versions	1–16
Restrictions	1–16

2 Remote Copy Set Features

Remote Copy	2–1
Remote Copy Sets	2–2
Non-Remote Copy Sets	2–2
Operation Modes	2–2
Synchronous Operation Mode	2–2
Asynchronous Operation Mode	2–3
Operation Mode Considerations	2–3
ADD REMOTE_COPY_SETS Command	2–4
Outstanding_IO Settings	2–4
Synchronous	2–4
Asynchronous	2–4
Outstanding Write Operations	2–5
High Outstanding I/O Values	2–5
Low Outstanding I/O Values	2–5
Suspend and Resume Switches	2–5
Error Mode Switch	2–5
Association Sets	2–6
Association Set Characteristics	2–6
FAIL_ALL Switch	2–7
ADD ASSOCIATIONS Command	2–8
Write History Logging	2–8
Write History Log Units	2–9
Write History Log Unit Restrictions	2–9
Reaching the End of a Write History Log Unit	2–9
Write History Log Unit Performance Considerations	2–10
Write History Log Unit Size Considerations	2–11
Switches	2–11
Write History Log Unit Switches	2–11
ORDER_ALL Switch	2–11
SUSPEND	2–12
RESUME	2–12
Failover	2–12
Planned Failover	2–12
Unplanned Failover	2–12

Failback	2–13
3 Getting Started	
Site, Host, and Solution Preparation	3–1
Host Bus Adapter Requirements	3–2
Setting Up the Fibre Channel Switches	3–3
Setting Up the Fiber Optic Cables	3–4
Host-to-Switch Connections	3–4
Switch-to-Controller Connections	3–5
Cascaded Switches	3–6
Hopping	3–7
Cascaded Switch Configurations	3–7
Multiple Intersite Links	3–10
4 Configuring a Standard Data Replication Manager Solution	
Introduction	4–2
Restrictions	4–3
Configuration Overview	4–6
Configuration Procedures Outline	4–6
Target Site Outline	4–6
Initiator Site Outline	4–7
Configure the Controllers at the Target Site	4–8
Configure Storage at the Target Site	4–16
Devices and Stagesets	4–16
Create Storage Units	4–16
Cable the Target Site	4–19
Connect Fiber Optic Cables Between Controllers and Fibre Channel Switches	4–19
Connect the Target Site to the External Fiber Link	4–21
Long Wave or Very Long Distance GBICs	4–21
Other Transport Modes	4–21
Create Switch Zones at the Target Site	4–22
Configure the Host at the Target Site	4–23
Compaq OpenVMS	4–23
Install the Host Bus Adapters	4–23
Install SWCC (Optional)	4–24
Additional Setup	4–24
Connect the Host to the SAN	4–24
Rename the Host Connections	4–25

Update Switch Zones	4-26
Compaq Tru64 UNIX	4-27
Install the Host Bus Adapters	4-27
Install the Host Bus Adapter Driver	4-27
Multipath Software	4-27
Install SWCC (Optional)	4-27
Connect the Host to the SAN	4-28
Rename the Host Connections	4-28
Update Switch Zones	4-29
HP-UX	4-30
Existing Fibre Channel HP-UX Configurations	4-30
Install the Host Bus Adapters	4-30
Connect the Host to the SAN	4-30
Rename the Host Connections	4-31
Update Switch Zones	4-31
Disable Access to the Hosts at the Target Site	4-32
Install the Secure Path Fibre Channel Host Bus Adapter Device Driver	4-32
Verify the Disks	4-32
Configure the SWCC Agent (Optional)	4-33
Additional Setup	4-33
IBM AIX	4-33
Install the Host Bus Adapters	4-33
Install the Secure Path Fibre Channel Host Bus Adapter Device Driver and the AIX Platform Kit	4-33
New Installation	4-34
New Installation Assumptions	4-34
HBA Limitations	4-34
Installation Steps	4-34
Upgrade Installation	4-37
Upgrade Installation Assumptions	4-37
HBA Limitations	4-37
Installation Steps	4-37
Connect the Host to the SAN	4-41
Rename the Host Connections	4-41
Update Switch Zones	4-42
Disable Access to the Hosts at the Target Site	4-42
Verify the Disks	4-42
Configure the SWCC Agent (Optional)	4-43

Additional Setup	4-43
Microsoft Windows NT and Windows 2000.	4-43
Install the Host Bus Adapters and Update Firmware	4-43
Install the Host Bus Adapter Driver	4-44
Install Fibre Channel Software	4-44
Install Multipath Software	4-44
Install SWCC (Optional).	4-45
Connect the Host to the SAN	4-45
Rename the Host Connections	4-45
Update Switch Zones	4-47
Novell NetWare.	4-47
Install the Host Bus Adapters	4-47
Install the Host Bus Adapter Driver	4-47
Install Secure Path Agent	4-47
Install Secure Path Manager	4-48
Install SWCC (Optional).	4-49
Connect the Host to the SAN	4-49
Rename the Host Connections	4-49
Update Switch Zones	4-50
Sun Solaris.	4-51
Install the Host Bus Adapters	4-51
Connect the Host to the SAN	4-51
Install the Solaris Platform Kit	4-52
Rename the Host Connections	4-52
Update Switch Zones	4-53
Enable Access to the Hosts at the Target Site.	4-54
Verify the Disks	4-54
Install Secure Path for Solaris Software	4-54
Reverify the Disks.	4-54
Configure SWCC Agent (Optional)	4-55
Disable Access to the Hosts at the Target Site	4-55
Additional Setup	4-55
Configure the Controllers at the Initiator Site	4-55
Configure Storage at the Initiator Site	4-63
Devices and Storagesets	4-63
Create Storage Units	4-63
Cable the Initiator Site	4-65
Connect Fiber Optic Cables Between Controllers and Fibre Channel Switches.	4-65

Connect the Initiator Site to the External Fiber Link	4-67
Long Wave or Very Long Distance GBICs	4-67
Other Transport Modes	4-68
Create Switch Zones	4-69
Create Remote Copy Sets	4-69
Prepare the Initiator Site	4-69
Create Connections from the Target Site	4-70
Create Remote Copy Sets from the Initiator Site	4-70
Set Failsafe at the Initiator Site (Optional)	4-72
Create Write History Log Units and Association Sets (Optional)	4-72
Create a Write History Log Unit	4-73
Create Association Sets and Assign a Write History Log Unit	4-74
Configure the Host at the Initiator Site	4-76
Compaq OpenVMS	4-76
Install the Host Bus Adapters	4-76
Install SWCC (Optional)	4-77
Additional Setup	4-77
Connect the Host to the SAN	4-77
Rename the Host Connections	4-78
Update Switch Zones	4-79
Enable Access to the Hosts at the Initiator Site	4-79
Compaq Tru64 UNIX	4-79
Install the Host Bus Adapters	4-79
Install the Host Bus Adapter Driver	4-80
Multipath Software	4-80
Install SWCC (Optional)	4-80
Connect the Host to the SAN	4-80
Rename the Host Connections	4-81
Update Switch Zones	4-82
Enable Access to the Hosts at the Initiator Site	4-82
HP-UX	4-83
Existing Fibre Channel HP-UX Configurations	4-83
Install the Host Bus Adapters	4-83
Connect the Host to the SAN	4-83
Rename the Host Connections	4-84
Update Switch Zones	4-84
Enable Access to the Hosts at the Initiator Site	4-85
Install the Secure Path Fibre Channel Host Bus Adapter Device Driver	4-85

Verify the Disks	4-85
Configure the SWCC Agent (Optional)	4-85
Additional Setup	4-86
IBM AIX	4-86
Install the Host Bus Adapters	4-86
Install the Secure Path Fibre Channel Host Bus Adapter Device Driver and the AIX Platform Kit	4-86
New Installation	4-87
New Installation Assumptions	4-87
HBA Limitations	4-87
Installation Steps	4-87
Upgrade Installation	4-89
Upgrade Installation Assumptions	4-89
HBA Limitations	4-90
Installation Steps	4-90
Connect the Host to the SAN	4-93
Rename the Host Connections	4-94
Update Switch Zones	4-94
Enable Access to the Hosts at the Initiator Site	4-95
Verify the Disks	4-95
Configure the SWCC Agent (Optional)	4-95
Additional Setup	4-96
Microsoft Windows NT and Windows 2000.	4-96
Install the Host Bus Adapters	4-96
Install the Host Bus Adapter Driver	4-96
Install Fibre Channel Software	4-96
Install Multipath Software	4-97
Install SWCC (Optional).	4-97
Connect the Host to the SAN	4-97
Rename the Host Connections	4-98
Update Switch Zones	4-99
Novell NetWare.	4-100
Install the Host Bus Adapters	4-100
Install the Host Bus Adapter Driver	4-100
Install Secure Path Agent	4-100
Install Secure Path Manager	4-101
Install SWCC (Optional).	4-101
Connect the Host to the SAN	4-102

Rename the Host Connections	4-103
Update Switch Zones	4-104
Enable Access to the Hosts at the Initiator Site	4-104
Sun Solaris	4-105
Install the Host Bus Adapters	4-105
Connect the Host to the SAN	4-106
Install the Solaris Platform Kit	4-106
Rename the Host Connections	4-107
Update Switch Zones	4-108
Enable Access to the Hosts at the Initiator Site	4-108
Verify the Disks	4-108
Install Secure Path for Solaris Software	4-109
Reverify the Disks	4-109
Configure the SWCC Agent (Optional)	4-109
Additional Setup	4-109
Additional Host Configuration	4-109
Install Cluster Server for Windows NT and Windows 2000 (Optional)	4-110
Install NetWare Cluster Services (NWCS) Version 1.01 (Optional)	4-110
Documenting Your Configuration	4-110
Terminal Emulator Session	4-110
SHOW Commands	4-111

5 Configuring the Optional Entry-Level DRM Solutions

Overview	5-1
Dual Switch Single Site Configuration	5-2
Setting Up the Dual Switch Single Site DRM Configuration	5-4
Single Switch Configuration	5-5
Setting Up the Single Switch Configuration	5-6
Single Fabric Configuration	5-8
Setting Up the Single Fabric Configuration	5-10

6 Configuring the Optional Advanced DRM Solutions

Bidirectional DRM Solution	6-1
Stretched Cluster DRM Solution	6-3

7 Troubleshooting

Preliminary Checks	7-2
Information from the Controllers	7-3

Step 1: Issue a SHOW THIS Command	7-3
Step 2: Issue a SHOW OTHER Command	7-6
Step 3: Issue a SHOW CONNECTIONS Command	7-8
Information from the Switches.	7-11
Step 4: Issue switchShow Command from the First Switch	7-12
Step 5: Issue switchShow Command from the Second Switch	7-14
Step 6: Issue switchShow Command from the Third Switch	7-16
Step 7: Issue switchShow Command from the Fourth Switch	7-18
Information from the Operating Systems.	7-20
Step 8: Associating HBAs with Servers	7-21
Compaq OpenVMS.	7-21
Compaq Tru64 UNIX	7-21
HP-UX	7-21
IBM AIX.	7-22
Microsoft Windows NT and Windows 2000	7-22
Novell NetWare	7-23
Sun Solaris	7-23
Other Troubleshooting Considerations	7-25
Show Commands.	7-25
SHOW UNITS FULL	7-25
SHOW REMOTE FULL	7-26
Zoning	7-27
Secure Path	7-27
Controller Replacement in a DRM Configuration.	7-27
Procedure When Replacement Controller Status is Unknown	7-27
Procedure When Non-DRM Controller Subsystem is Not Available	7-28

8 Zoning in the Storage Area Network

Switch Zoning	8-1
Planning Considerations for Homogeneous and Heterogeneous Configurations That Require Zoning.	8-2
More than 96 Host Connections	8-2
Zoning Hosts and HSG80 Subsystems Between Sites.	8-2
Zoning A DRM Configuration.	8-3
DRM Homogeneous Configuration.	8-3
Example: Zoning Green Zone_Top and Green Zone_Bottom	8-7
Example: Zoning Blue Zone_Top and Blue Zone_Bottom	8-9
Example: Zoning Red Zone_Top and Red Zone_Bottom	8-12

Create the Zone Names	8-14
Create the Configuration Name	8-15
DRM Heterogeneous Configuration	8-16
Example: Zoning Yellow Zone_Top and Yellow Zone_Bottom	8-18
Example: Zoning Brown Zone_Top and Brown Zone_Bottom	8-21
Create the Zone Names	8-23
Add the New Zones to the Configuration	8-24
Zoning to Allow Host Access Between Sites	8-29

A Status Comparison

Target Site Terminal Emulator Session	A-1
Issuing SHOW Commands	A-1
Example Display 1	A-2
Example Display 2	A-4
Example Display 3	A-4
Example Display 4	A-5
Example Display 5	A-5

B Replicating Storage Units

Cloning Data for Backup	B-2
Snapshot	B-6
Snapshot Command	B-7

C Upgrading to ACS Version 8.6-4P Software

Rolling Upgrade Procedure for 8.6-4P	C-1
Initiator Site Upgrade Procedure	C-1
Target Site Upgrade Procedure	C-5
Completion of the Initiator Site Upgrade Procedure	C-8
Shutdown Upgrade Procedure for 8.6-4P	C-9
Initiator Site Shutdown Upgrade Procedure	C-9
Target Site Shutdown Upgrade Procedure	C-11
Completion of Initiator Site Shutdown Upgrade Procedure	C-14

Glossary

Index

Figures

1-1	ESA12000 SBB.	1-5
1-2	Additional components for ESA12000 Data Replication Manager	1-6
1-3	Components for EMA12000 modular storage Data Replication Manager.	1-8
1-4	Fibre Channel SAN Switch 16	1-9
1-5	Fibre Channel SAN Switch 8-EL	1-9
1-6	Fibre Channel-based, ESA12000 DT storage subsystem (with fully-redundant power)	1-13
1-7	Fibre Channel-based, EMA12000 DT modular storage subsystem (with fully-redundant power)	1-14
2-1	Remote copy set operation modes	2-3
2-2	Location of association sets on the initiator controller pair	2-7
3-1	Locations and names of components for connecting fiber optic lines	3-4
3-2	Cascaded switches in a DRM environment	3-8
3-3	Cascaded switches in DRM environment with three hops between host and controller	3-9
3-4	Multiple intersite links	3-10
4-1	Data Replication Manager basic configuration.	4-2
4-2	Cabling between the controllers and the Fibre Channel switches	4-20
4-3	Cabling from the target site to the initiator site	4-22
4-4	Host renaming worksheet	4-25
4-5	Cabling between the controllers and the Fibre Channel switches	4-67
4-6	Cabling from the initiator to the target site.	4-68
5-1	DRM dual switch single site configuration.	5-3
5-2	Single switch DRM configuration	5-6
5-3	Dual switch with single ISL	5-9
6-1	Bidirectional DRM configuration.	6-2
7-1	Controller pair World Wide IDs	7-6
7-2	First cabling diagram	7-14
7-3	Second cabling diagram	7-16
7-4	Third cabling diagram.	7-18
7-5	Fourth cabling diagram	7-20
7-6	Final configuration	7-24
8-1	Zoning in a DRM homogeneous environment	8-4

8-2	Zoning a DRM example	8-6
8-3	Zoning in a DRM heterogeneous environment	8-17
8-4	DRM example showing the new zones	8-18
B-1	Steps the CLONE utility follows for duplicating unit members	B-4
B-2	Snapshot unit	B-7
C-1	Controller reset button and first three LEDs	C-3

Tables

1	Document Conventions	xix
1-1	ESA12000 Storage Rack Components	1-4
1-2	EMA12000 Modular Storage Rack Components	1-7
1-3	Platform-Specific Rack Documentation	1-11
2-1	Controller Option Settings for DRM.	2-13
3-1	Platform-Specific Rack Documentation	3-2
3-2	Example of Wiring for First Server and First Storage Array at Each Site	3-6
4-1	Restrictions	4-3
5-1	Comparison of Entry-Level Configurations	5-1
7-1	SHOW THIS Command Analysis.	7-4
7-2	SHOW OTHER Command Analysis	7-6
7-3	SHOW CONNECTIONS Command Analysis	7-9
7-4	Switch Version Command.	7-12
7-5	First switchShow Command Output	7-12
7-6	Second switchShow Command Output	7-14
7-7	Third switchShow Command Output	7-17
7-8	Fourth switchShow Command Output	7-19
7-9	SHOW UNITS FULL Command Output	7-25
7-10	SHOW REMOTE FULL Command Output	7-26
8-1	Blank zoning input form template.	8-5
8-2	Green Zone_Top and Green Zone_Bottom input form.	8-7
8-3	Blue Zone_Top and Blue Zone_Bottom input form	8-10
8-4	Red Zone_Top and Red Zone_Bottom input form	8-12
8-5	Yellow Zone_Top and Yellow Zone_Bottom input form.	8-19
8-6	Brown Zone_Top and Brown Zone_Bottom input form.	8-21
B-1	Cloning and Snapshot Comparison	B-1

About this Guide

This configuration guide provides information to help you:

- Understand *SANworks*[™] Data Replication Manager by Compaq hardware requirements and configurations.
- Understand remote copy set concepts.
- Set up and cable your Data Replication Manager (DRM) solution.
- Consider entry level and advanced configurations.
- Troubleshoot your DRM configuration.
- Decide how zoning will help your DRM configuration.
- Contact technical support for additional assistance.

What's New

This release of the *SANworks Data Replication Manager by Compaq HSG80 ACS Version 8.6-4P Configuration Guide* differs from the November 2001 release (part number AA-RPHZB-TE) as follows:

- Novell 6.0 is now supported. The subjects of NetWare traditional and logical volumes have been added to the Novell-specific procedures in Chapter 4.
- The IBM-AIX alternative steps for installing the Platform Kit and Secure Path have been transferred from the Release Notes to Chapter 4.
- Appendix C has been revised to indicate that:
 - The rolling upgrade procedure is not currently supported for Microsoft Windows NT, Microsoft Windows 2000, and IBM AIX platforms.
 - The rolling upgrade procedure is not supported for ACS versions prior to Version 8.5.

Intended Audience

This book is intended for use by system administrators who are experienced with the following:

- *Compaq StorageWorks™ ACS Version 8.6-4P* for their Data Replication Manager storage system.
- Administration of the various operating systems used by the hosts in their heterogeneous SAN.

Related Documentation

The following table lists documents that you may need to reference when connecting, configuring, and operating your DRM solution.

Document Title	Part Number
Compaq KGPSA-BC PCI-to-Optical Fibre Channel Host Bus Adapter User's Guide	AA-RF2JB-TE
Compaq SANworks Data Replication Manager over an ATM Link Application Notes	EK-DRMAL-AA
SANworks Data Replication Manager by Compaq HSG80 ACS Version 8.6-4P Release Notes	AA-RPJ2B-TE
SANworks Data Replication Manager by Compaq HSG80 ACS Version 8.6-1P Scripting User Guide	EK-DRMSC-OA
SANworks Data Replication Manager by Compaq HSG80 Version 8.6-4P Failover/Failback Procedures Guide	AA-RPJOC-TE
Compaq SANworks Data Replication Manager Using Very Long Distance GBICs Application Notes	EK-DRMLD-AA
Compaq SANworks Secure Path for Sun Solaris Version 2.1A/2.1C Installation and Reference Guide	AA-RKYDB-TE
Compaq SANworks Secure Path Version 2.0 for IBM AIX Installation and Reference Guide	AA-RLTOA-TE
Compaq SANworks Secure Path Version 3.0 for HP-UX Installation and Reference Guide	AA-RR4VA-TE
Compaq SANworks Secure Path Version 3.0 for Novell NetWare Installation and Reference Guide	AA-RN72A-TE

Document Title	Part Number
Compaq SANworks Secure Path Version 3.1 for Microsoft Windows Installation and Reference Guide	AA-RL4SC-TE
Compaq SANworks Storage Resource Manager Version 1.0 for Exchange Installation Guide	AA-RLFMA-TE
Compaq SANworks Switch Zoning Reference Guide	EK-P20ZG-GA
Compaq StorageWorks 64-Bit PCI-to-Fibre Channel Host Bus Adapter User Guide	AA-RKPDB-TE
Compaq StorageWorks Command Console Version 2.2 (HSG80) for RA8000/ESA12000 User's Guide	AA-RFA2D-TE
Compaq StorageWorks Command Console Version 2.4 User Guide	AA-RFA2H-TE
Compaq StorageWorks EMA System Rack User Guide	EK-MA41C-UA
Compaq StorageWorks EMA16000 System Rack User Guide	EK-MA41C-UA
Compaq StorageWorks Enclosure 4200 Family LVD Disk Enclosure User Guide	EK-SW2ZS-UA
Compaq StorageWorks Fibre Channel SAN Switch Management Guide	AA-RMMJA-TE
Compaq StorageWorks Fibre Channel Storage Switch Service Guide	AA-RHBZA-TE
SANworks by Compaq HSG80 ACS Version 8.6-4P Data Replication Manager Design Guide Application Notes	AA-RQ78A-TE
Compaq StorageWorks Fibre Channel Storage Switch User's Guide	AA-RHBYA-TE
Compaq StorageWorks Heterogeneous Open SAN Design Reference Guide	AA-RMPNA-TE
Compaq StorageWorks HSG80 ACS Solution Software Version 8.6 for Compaq OpenVMS Installation and Configuration Guide	AA-RH4BD-TE
Compaq StorageWorks HSG80 ACS Solution Software Version 8.6 for Compaq Tru64 UNIX Installation and Configuration Guide	AA-RFAUD-TE
Compaq StorageWorks HSG80 ACS Solution Software Version 8.6 for IBM AIX Installation and Configuration Guide	AA-RJ25D-TE

Document Title	Part Number
Compaq StorageWorks HSG80 ACS Solution Software Version 8.6 for HP-UX Installation and Configuration Guide	AA-RFBEG-TE
Compaq StorageWorks HSG80 ACS Solution Software Version 8.6 for Novell NetWare Installation and Configuration Guide	AA-RFB9E-TE
Compaq StorageWorks HSG80 ACS Solution Software Version 8.6 for Sun Solaris Installation and Configuration Guide	AA-RFBQG-TE
Compaq StorageWorks HSG80 ACS Solution Software Version 8.6 for Windows NT and Windows 2000 Installation and Configuration Guide	AA-RFA9F-TE
Compaq StorageWorks HSG80 Array Controller ACS Version 8.6 CLI Reference Guide	EK-G80CL-RA
Compaq StorageWorks HSG80 Array Controller ACS Version 8.6 Maintenance and Service Guide	EK-G80MS-SA
Compaq StorageWorks HSG80 Array Controller ACS Version 8.6 Troubleshooting Reference Guide	EK-G80TR-SA
Compaq StorageWorks Model 2100 and 2200 Ultra SCSI Controller Enclosure User Guide	EK-SE2C8-UA
Compaq StorageWorks SAN Switch Web Management Tools Reference Guide	EK-P20WW-GA
Compaq StorageWorks SBUS and PCI-Fibre Channel Host Bus Adapter for Sun Solaris Installation Guide	AA-RNXHA-TE
Compaq StorageWorks Ultra SCSI RAID Enclosure (DS-BA370-Series) User's Guide	EK-BA370-UG

Document Conventions

The conventions included in Table 1 apply in most cases.

Table 1: Document Conventions

Element	Convention
Key names, menu items, buttons, and dialog box titles	Bold
File names and application names	<i>Italics</i>
User input, command names, system responses (output and messages)	Monospace font COMMAND NAMES are uppercase unless they are case sensitive
Variables	<i>Monospace, italic font</i>
Website addresses	Sans serif font (http://www.compaq.com)

Symbols in Text

These symbols may be found in the text of this guide. They have the following meanings.



WARNING: Text set off in this manner indicates that failure to follow directions in the warning could result in bodily harm or loss of life.



CAUTION: Text set off in this manner indicates that failure to follow directions could result in damage to equipment or data.

IMPORTANT: Text set off in this manner presents clarifying information or specific instructions.

NOTE: Text set off in this manner presents commentary, sidelights, or interesting points of information.

Symbols on Equipment



Any enclosed surface or area of the equipment marked with these symbols indicates the presence of electrical shock hazards. Enclosed area contains no operator serviceable parts.

WARNING: To reduce the risk of injury from electrical shock hazards, do not open this enclosure.



Any RJ-45 receptacle marked with these symbols indicates a network interface connection.

WARNING: To reduce the risk of electrical shock, fire, or damage to the equipment, do not plug telephone or telecommunications connectors into this receptacle.



Any surface or area of the equipment marked with these symbols indicates the presence of a hot surface or hot component. Contact with this surface could result in injury.

WARNING: To reduce the risk of injury from a hot component, allow the surface to cool before touching.



Power supplies or systems marked with these symbols indicate the presence of multiple sources of power.

WARNING: To reduce the risk of injury from electrical shock, remove all power cords to completely disconnect power from the power supplies and systems.



Any product or assembly marked with these symbols indicates that the component exceeds the recommended weight for one individual to handle safely.

WARNING: To reduce the risk of personal injury or damage to the equipment, observe local occupational health and safety requirements and guidelines for manually handling material.

Rack Stability



WARNING: To reduce the risk of personal injury or damage to the equipment, be sure that:

- The leveling jacks are extended to the floor.
 - The full weight of the rack rests on the leveling jacks.
 - In single rack installations, the stabilizing feet are attached to the rack.
 - In multiple rack installations, the racks are coupled.
 - Only one rack component is extended at any time. A rack may become unstable if more than one rack component is extended for any reason.
-

Getting Help

If you still have a question after reading this guide, contact service representatives or visit our website.

Compaq Technical Support

In North America, call Compaq technical support at 1-800-OK-COMPAQ, available 24 hours a day, 7 days a week.

NOTE: For continuous quality improvement, calls may be recorded or monitored.

Outside North America, call Compaq technical support at the nearest location. Telephone numbers for worldwide technical support are listed on the Compaq website: <http://www.compaq.com>.

Be sure to have the following information available before calling:

- Technical support registration number (if applicable)
- Product serial numbers
- Product model names and numbers
- Applicable error messages
- Operating system type and revision level
- Detailed, specific questions.

Compaq Website

The Compaq website has the latest information on this product, as well as the latest drivers. Access the Compaq website at: <http://www.compaq.com/storage>. From this website, select the appropriate product or solution.

Compaq Authorized Reseller

For the name of your nearest Compaq Authorized Reseller:

- In the United States, call 1-800-345-1518.
- In Canada, call 1-800-263-5868.
- Elsewhere, see the Compaq website for locations and telephone numbers.

Introduction to Data Replication Manager

This chapter introduces the Data Replication Manager (DRM) and describes the required hardware and software components.

This chapter covers the following:

- “Data Replication Manager Overview” on page 1–2
- “Heterogeneous Storage Area Networks” on page 1–3
- “Required Hardware Components” on page 1–3
 - “Rack Components” on page 1–4
 - “ESA12000 Storage Rack” on page 1–4
 - “EMA12000 Modular Storage Rack” on page 1–7
 - “Fibre Channel Switches” on page 1–9
 - “Gigabit Interface Converters (GBICs)” on page 1–9
 - “Power Distribution Unit (PDU)” on page 1–10
 - “Fully-Redundant Power (Optional)” on page 1–11
 - “Host Bus Adapters” on page 1–11
- “Hardware Configurations” on page 1–11
- “Software Components” on page 1–14
 - “Array Controller Software” on page 1–14
 - “Secure Path” on page 1–14
 - “StorageWorks Command Console (Optional)” on page 1–14
 - “Supported Software Versions” on page 1–15
- “Restrictions” on page 1–15

Data Replication Manager Overview

A single DRM provides a disaster-tolerant (DT) storage solution through the use of hardware redundancy and data replication between two sites separated by some distance. Multiple heterogeneous servers can be connected to one or more shared storage subsystems.

A basic DRM configuration consists of two sites, an *initiator* and a *target*. The initiator site carries out primary data processing. The target site is used for data replication. As data processing occurs at the initiator site, the data is replicated or mirrored to the target site. If a single component at either site fails, DRM will fail over to a redundant component at the same site to allow continued operation. For example, if one of the dual-redundant Fibre Channel links between the sites were to fail, DRM would fail over to the other link. If a significant failure (disaster) occurs at the initiator site, data processing can be resumed at the target site, where the data is intact. This process is called *site failover*. When the cause of the initiator site failover has been resolved, data processing can be moved back to the initiator site in a process called *site failback*.

DRM uses the peer-to-peer remote copy function of the HSG80 controller to achieve data replication. HSG80 controller pairs at the initiator site are connected to their partner HSG80 controller pairs at the target site. This process is completely host independent.

The connection between the two DRM sites is called an *intersite link* (ISL). There are two ISLs for redundancy. An ISL can be one of several transport modes. For example, short distances can use direct Fibre Channel links, while longer distances require asynchronous transport mode (ATM). For more detailed information on supported ISLs, refer to the *Compaq SANworks Data Replication Manager over an ATM Link Application Note*, the *Compaq SANworks Data Replication Manager Using Very Long Distance GBICs Application Note*, and to the DRM web page:

<http://www.compaq.com/products/sanworks/drm/index.html>

Follow the Software Support Matrices link, then choose your operating system.

Heterogeneous Storage Area Networks

This section describes heterogeneous storage area networks (SANs) in a DRM environment. Previous implementations of DRM required all operating systems in a DRM environment to be the same (homogeneous). The latest version of the *Compaq StorageWorks™* Array Controller Software (ACS) supports a mixed (heterogeneous) environment of operating systems, making DRM much more scalable and manageable in a customer data center.

SANs are becoming more complicated to manage and maintain. In today's Information Technology world, few businesses carry out their day-to-day operations within a single operating system (OS) topology. Many businesses have a mixture of operating system platforms carrying out different business functions. They may have electronic mail services running on Windows 2000, critical business applications on UNIX, and file-print services on NetWare. These may be running in several data centers on several different SANs. By using a heterogeneous DRM SAN environment, they can be combined into a single SAN and use a single implementation of DRM for business critical applications.

Refer to the *Compaq StorageWorks Heterogeneous Open SAN Design Reference Guide* for more information on designing and building heterogeneous SANs. If the *Heterogeneous Open SAN Design Reference Guide* contradicts this guide, consider this guide correct for DRM configurations only.

Required Hardware Components

DRM uses a minimum of two HSG80 Array Controller pairs: one at the initiator site and one at the target site. Each site must have one or more ESA12000 racks or EMA12000/EMA16000 modular storage racks:

- RA8000/ESA12000 racks are equipped with one or more BA370 enclosures and disk Storage Building Blocks (SBBs). Each BA370 enclosure holds up to 24 disks.
- MA8000/EMA12000/EMA16000 modular storage racks are equipped with one or more controllers and modular disk SBBs.

The hosts at the initiator and target sites are connected to a pair of dual redundant HSG80 Array Controllers, which are located inside the enclosures. Connections between the controllers and hosts are made at each site with two Fibre Channel switches and two host bus adapters (HBAs). For complete details on this equipment, refer to the storage rack installation reference guide for your operating system.

NOTE: While this documentation addresses ESA12000 storage racks as a primary unit for DRM configurations, the Compaq DT solution functions in any equivalent rack that houses a BA370 enclosure.

For the EMA12000/EMA16000 modular storage racks, the Compaq DT solution functions in any equivalent rack that houses the same number of controllers and an equivalent drive configuration.

Rack configurations may also be combined between the ESA12000 racks and EMA12000/EMA16000 modular storage racks. For example, if the disk configurations are equivalent, an ESA12000 rack may be used at one site (initiator or target) and an EMA12000/EMA16000 modular storage rack may be used at the associated site (target or initiator).

Rack Components

Tables and figures throughout this chapter show hardware that is necessary or optional to complete a modular DRM solution for each of two types of rack configurations, the ESA12000 rack and the EMA12000/EMA16000 modular storage rack.

For detailed information about these components, refer to the following documents:

- The Compaq *StorageWorks HSG80 ACS Solution Software Version 8.6-4P* for your operating system
- *Compaq StorageWorks HSG80 Array Controller ACS Version 8.6 CLI Reference Guide*
- *Compaq StorageWorks HSG80 Array Controller ACS Version 8.6 Maintenance and Service Guide*

ESA12000 Storage Rack

The ESA12000 SBB rack houses the BA370 enclosures, which contain the components listed in Table 1–1.

Table 1–1: ESA12000 Storage Rack Components

Two HSG80 Fibre Channel RAID ARRays Controllers
One Environmental Monitoring Unit (EMU)
One or two AC input power controllers
Up to 24 disk drive SBBs per BA370 enclosure
Five to eight 180-watt power supplies
Dual external cache batteries (ECB)s
Six single-ended I/O Ultra SCAI modules
Eight cooling fans

Table 1–1: ESA12000 Storage Rack Components (Continued)

One Power Verification and Addressing (PVA) module
Two cache modules (512 MB each required) for each HSG80

Figure 1–1 shows the initial SBB parts inside the ESA12000 rack with a 24 disk-drive capacity.

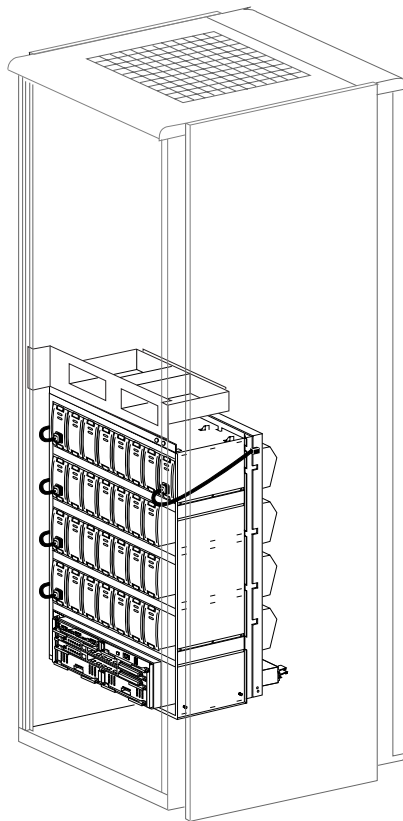

CXO6843A

Figure 1–1: ESA12000 SBB

Figure 1–2 shows additional components that must be added to the ESA12000 building block to support a DRM solution, including Fibre Channel switches. The optional redundant power distribution unit is also shown.

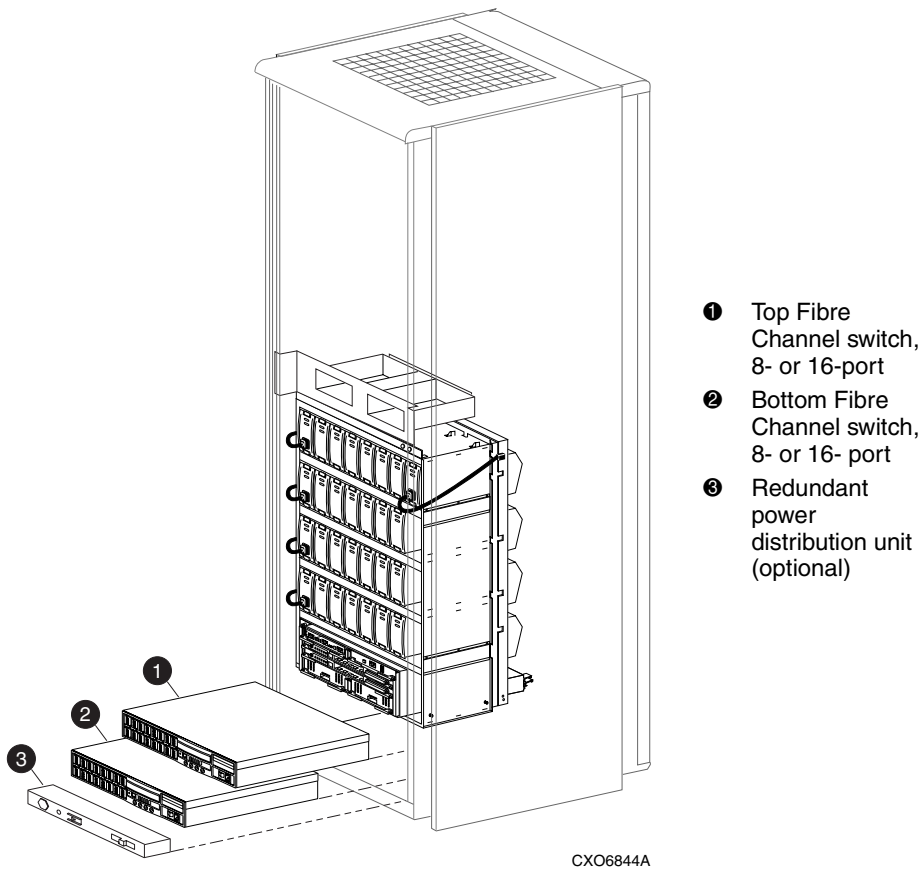

Figure 1–2: Additional components for ESA12000 Data Replication Manager

EMA12000 Modular Storage Rack

The EMA12000 modular SBB racks include power distribution units, are pre-cabled, and contain the components listed in Table 1–2.

Table 1–2: EMA12000 Modular Storage Rack Components

Two HSG80 Fibre Channel RAID Array Controllers
Two Environmental Monitoring Units (EMUs)
Two AC input power controllers
Modular disk drive SBBs:
D14 - Up to 42 drives per controller subsystem
S14 - Up to 72 drives per controller subsystem
Blue - Up to 42 drives per controller subsystem
Dual power supplies, one set per enclosure
Dual external cache batteries (ECBs)
Dual cooling fans, one set per enclosure
Six single-ended I/O Ultra SCSI modules
Two cache modules (512 MB each required)

Figure 1–3 shows an EMA12000 modular building block that supports a DRM solution. The modular SBB consists of the controller enclosure and the disk enclosure. The redundant power distribution unit is also shown.

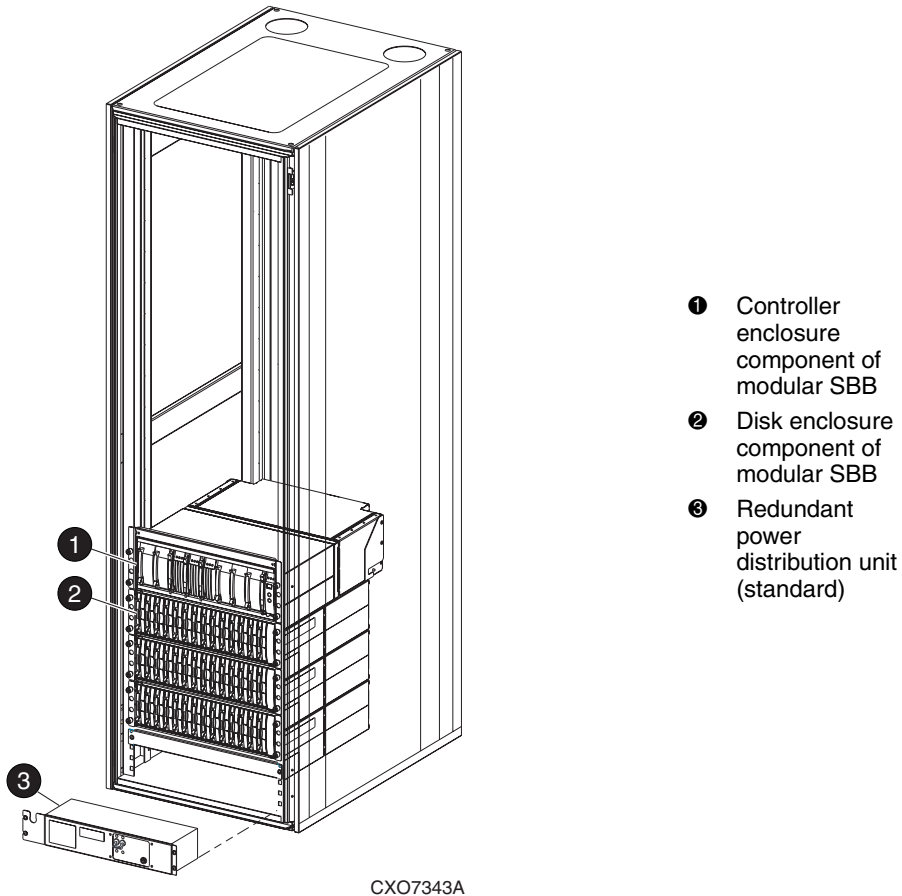

Figure 1–3: Components for EMA12000 modular storage Data Replication Manager

Switches are placed in a different rack in this configuration of the EMA12000 D14 high-performance modular storage rack. A command center rack can be used to contain the switches.

Fibre Channel Switches

The Fibre Channel switches shown in Figure 1–4 and Figure 1–5 are two types of SAN switches used to connect the controllers to the hosts and to link the initiator and target sites together. The figures illustrate, respectively, the Fibre Channel SAN Switch 16 and the Fibre Channel SAN Switch 8-EL. The ports hold short-wave, long-wave, or very long distance Gigabit Interface Converters (GBICs), which are described in the next section.

Refer to the *Compaq StorageWorks Fibre Channel Storage Switch User's Guide* for an in-depth look at the features and functions of the Fibre Channel switches. Refer to the *Compaq StorageWorks Fibre Channel SAN Switch Management Guide* for additional detail on SAN switches.

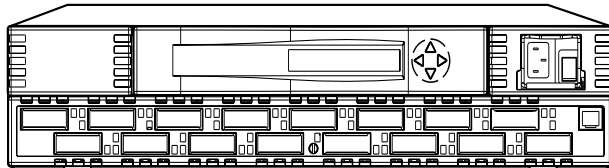

CXO7085A

Figure 1–4: Fibre Channel SAN Switch 16

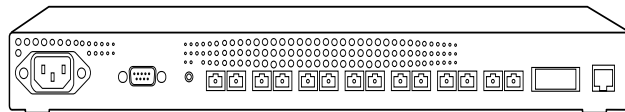

CXO7337A

Figure 1–5: Fibre Channel SAN Switch 8-EL

Gigabit Interface Converters (GBICs)

GBICs are the converters that are inserted into the ports of the Fibre Channel switch and serve as the interface between the fiber optic cables and the switch. Short-wave GBICs are used with a 50-micron multi-mode fiber optic cable (SC-terminated) to connect the components at the initiator and target sites (host-to-switch; controller-to-switch). The maximum distance that short-wave GBICs support is 500 meters.

Long-wave GBICs are used with 9-micron single-mode fiber optic cables (SC-terminated) to link the initiator and target sites. Standard long-wave GBICs connect switches that are up to 10 kilometers apart.

Very long distance GBICs are used with 9-micron single-mode fiber optic cables (SC-terminated) to link the initiator and target sites. Standard very long distance GBICs connect switches that are up to 100 kilometers apart.

Refer to the *Compaq StorageWorks Fibre Channel Storage Switch User's Guide* and the *Compaq SANworks Data Replication Manager Using Very Long Distance GBICs Application Note* to learn more about GBICs.

Power Distribution Unit (PDU)

The PDU component is included with the ESA12000 and EMA12000 racks:

- For the RA8000/ESA12000 racks, the PDU distributes power to the BA370s and switches. You can order a second PDU to support a fully-redundant MA8000/ESA12000 power configuration.
- For the RA8000/EMA12000 racks, the PDU distributes power to the modular configurations of controllers. PDU redundancy is included with MA8000/ESA12000 modular configurations.

For more detailed information, refer to the documents listed in Table 1–3.

Table 1–3: Platform-Specific Rack Documentation

- | |
|--|
| <ul style="list-style-type: none">• Compaq StorageWorks HSG80 ACS Solution Software Version 8.6 for Compaq Tru64 UNIX Installation and Configuration Guide• Compaq StorageWorks HSG80 ACS Solution Software Version 8.6 for Compaq OpenVMS Installation and Configuration Guide• Compaq StorageWorks HSG80 ACS Solution Software Version 8.6 for HP-UX Installation and Configuration Guide• Compaq StorageWorks HSG80 ACS Solution Software Version 8.6 for IBM AIX Installation and Configuration Guide• Compaq StorageWorks HSG80 ACS Solution Software Version 8.6 for Novell NetWare Installation and Configuration Guide• Compaq StorageWorks HSG80 ACS Solution Software Version 8.6 for Sun Solaris Installation and Configuration Guide• Compaq StorageWorks HSG80 ACS Solution Software Version 8.6 for Windows NT and Windows 2000 Installation and Configuration Guide• Compaq StorageWorks EMA16000 System Rack User Guide |
|--|

Fully-Redundant Power (Optional)

Fully-redundant power is an optional feature designed to offer a more secure source of power in case one or more units fail. If fewer than five power components are operational, the entire rack shuts down.

The fully-redundant power feature requires three additional power supplies, as well as one additional AC power controller that plugs into one additional PDU. For the ESA12000 rack, these additional components must be supplied for each BA370 enclosure. For the EMA12000 modular storage rack, the preconfiguration models (D14, S14, Blue) feature fully-redundant enclosures.

For more details about power supply SBB, refer to the documents listed in Table 1–3.

Host Bus Adapters

The HBAs are inserted into the available slots on the host computer's PCI bus. A Fibre Channel connection is made by inserting a multi-mode fiber optic cable between each adapter and an individual port on the Fibre Channel switch.

For a list of the most current software, firmware, patches, drivers, and so on, for each of the supported operating systems in your DRM solution, go to the following website:

<http://www.compaq.com/products/sanworks/drm/index.html>

Follow the Software Support Matrices link, then choose your operating system.

Hardware Configurations

Figures shown previously in this chapter have reflected the build of a DT solution for each of two types of rack configurations. Figure 1–6 shows a completed DT setup for the ESA12000 rack. Figure 1–7 shows a completed DT setup for the EMA12000 modular storage rack.

NOTE: If you prefer to join racks for more storage capacity, follow the instructions in the documents listed in Table 1–3.

Be sure to establish the same setup at both the initiator and target sites. Keep in mind that an additional rack will not include switches or controllers. It does, however, include a PDU and is able to support redundant power.

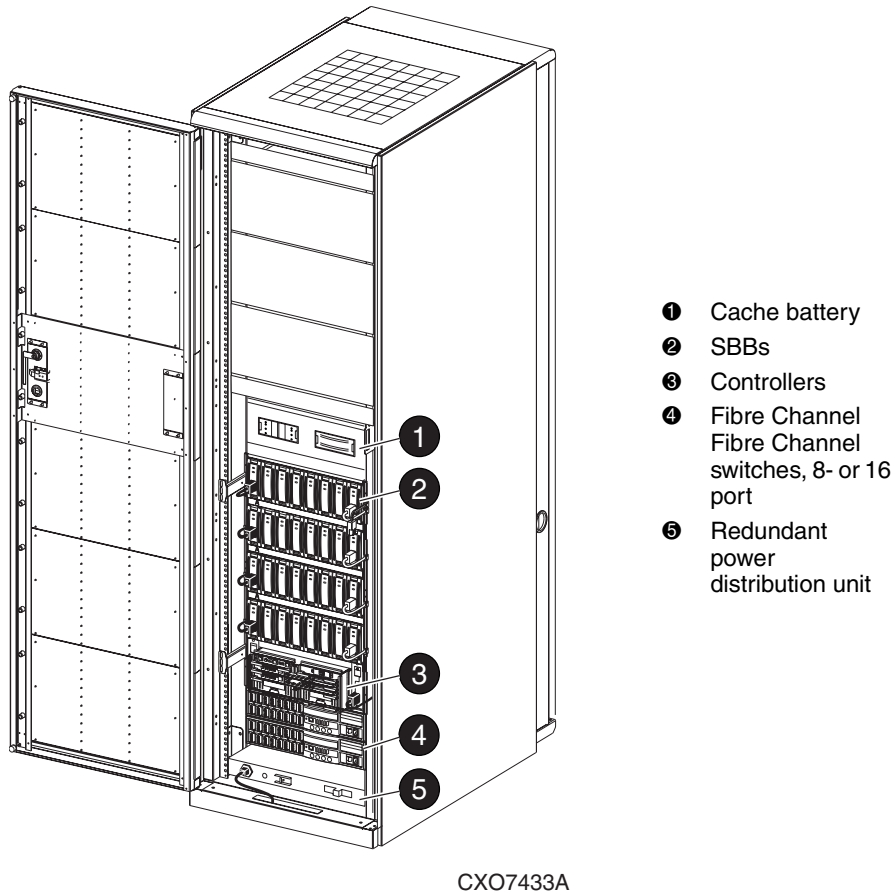
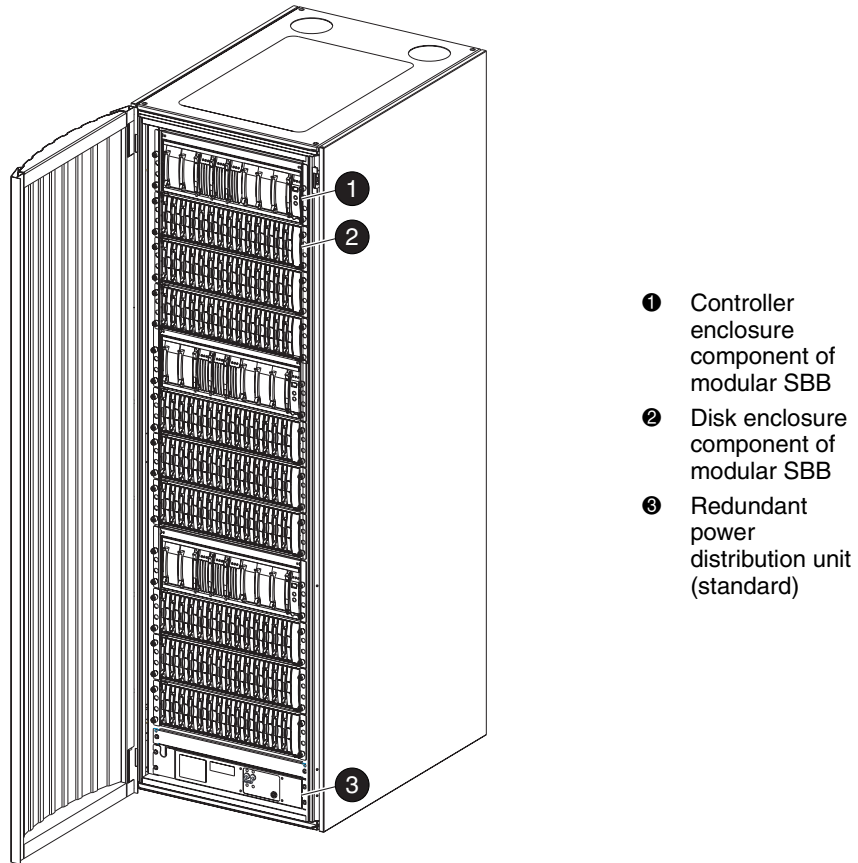

Figure 1-6: Fibre Channel-based, ESA12000 DT storage subsystem (with fully-redundant power)



CXO7434A

Figure 1–7: Fibre Channel-based, EMA12000 DT modular storage subsystem (with fully-redundant power)

Software Components

This section describes the software components necessary to configure and manage a DT storage subsystem. For installation instructions, see Chapter 4, “Configuring a Standard Data Replication Manager Solution.”

Array Controller Software

HSG80 Array Controller Software (ACS) is the software component of the HSG80 Array Controller subsystem. ACS software executes on the HSG80 controller and processes I/O requests from the host, performing the device-level operations required to satisfy the requests. The ACS Version 8.6-4P supports DRM.

Secure Path

Secure Path is an additional server-based software that enhances the *StorageWorks* RAID dual-ported storage subsystem by providing automatic error recovery from server-to-storage subsystem connection failures. Secure Path allows you to add redundant Fibre Channel paths between hosts and a RAID storage subsystem, improving overall data availability. If any component in the path between the host and storage subsystem fails, Secure Path immediately redirects all pending and subsequent I/O requests from the failed path to the alternate path, preventing an adapter, cable, or controller failure from disrupting data access.

Secure Path is required for operating systems (such as HP-UX, IBM AIX, Microsoft Windows NT, Microsoft Windows 2000, Novell NetWare, and Sun Solaris) that do not have native multipath support. Compaq *Tru64™* UNIX and Compaq *OpenVMS™* do have native multipath support and do not require Secure Path. Secure Path is a separate product from DRM and must be ordered in addition to ACS Version 8.6-4P. For more information on Secure Path, refer to the Secure Path documentation for your operating system.

StorageWorks Command Console (Optional)

StorageWorks Command Console (SWCC) provides local and remote management of *StorageWorks* controllers and their attached storage devices. SWCC consists of two major components: the SWCC client and the SWCC agent. SWCC can be used to configure and manage the DT storage subsystem.

The SWCC client is a companion to the agent; it is a graphical user interface (GUI) that runs on a local host and displays the logical and physical layout and status of a selected subsystem in graphical form.

The SWCC agent is a host-resident program that is an interface between the client and the host's storage subsystem that allows the two to communicate over a network.

For a full description of SWCC and how it operates, refer to the *Compaq StorageWorks Command Console Version 2.4 User Guide*.

Supported Software Versions

For a list of the most current software, firmware, patches, drivers, and so on, for each of the supported operating systems in your DRM solution, go to the following website:

<http://www.compaq.com/products/sanworks/drm/index.html>

Follow the Software Support Matrices link, then choose your operating system.

Restrictions

The HSG80 controller does not distinguish between commands issued from in-band command tools (SWCC, Command Scripter, and *SANworks* Management Appliance) and commands issued out-of-band through the serial port. Serial port commands should only be performed when the customer has restricted commanding from other sources. Special care must be taken with the Management Appliance, as it periodically issues polling commands that can interrupt serial port communications. If you will be using the serial port on the HSG80 controller, remove the Management Appliance from the fabric or use switch zoning to isolate the Management Appliance from the array in which controllers are commanded through a serial port.

Remote Copy Set Features

This chapter discusses Data Replication Manager (DRM) concepts you need to know to configure a DRM solution. These descriptions include remote copy sets and association sets.

This chapter discusses the following topics:

- “Remote Copy” on page 2–2
 - “Remote Copy Sets” on page 2–2
 - “Non-Remote Copy Sets” on page 2–2
 - “Operation Modes” on page 2–3
 - “ADD REMOTE_COPY_SETS Command” on page 2–4
- “Association Sets” on page 2–6
 - “Association Set Characteristics” on page 2–7
 - “ADD ASSOCIATIONS Command” on page 2–8
 - “Write History Logging” on page 2–9
 - “Switches” on page 2–12
 - “Failover” on page 2–13
 - “Failback” on page 2–14

Remote Copy

DRM uses the peer-to-peer remote copy function of the HSG80 controller to achieve data replication. The HSG80 controller pairs at the initiator site are connected to their partner HSG80 controller pairs at the target site. Remote copy sets are mirrors of each other and are created from units at the initiator and target sites. As data is written to a unit at the initiator site, it is mirrored to its remote copy set partner unit at the target site.

The remote copy feature is intended not only for disaster recovery but also to replicate data from one storage subsystem or physical site to another subsystem or site. It also provides a method to perform a backup at either the local or remote site.

With remote copy, user applications continue to run while data movement goes on in the background over a separate interconnect. Data warehousing, continuous computing, and enterprise applications all require remote copy capabilities. The remote copy feature is the major component in the *StorageWorks* DRM solution.

Remote Copy Sets

A remote copy set is a bound set of two units—one at the initiator site and the other at the target site—for long-distance mirroring. The term *unit* is defined as a single disk, storageset, mirrorset, or RAIDset. The local controller is designated the *initiator*. The initiator acts as the director of the replication process. The corresponding remote controller is designated the *target*. The target receives I/O requests from the initiator to replicate the data at its location.

Remote copy sets are created only at the initiator site. There can be up to 12 remote copy sets per controller.

Non-Remote Copy Sets

Non-remote copy sets can exist on the same subsystem at the initiator or the target site, or both, and are generally used for local storage at each site. Clones and snapshots of existing remote copy sets are non-remote copy sets and can be created for activities like testing and backup. Since the non-remote copy sets are unique to the specific controller pair, data is not site disaster tolerant, but can use the various RAIDset types for failure tolerance.

Operation Modes

There are two possible remote copy operation modes: *Synchronous* and *Asynchronous*. Figure 2–1 shows the timeline differences between the two.

Synchronous Operation Mode

In synchronous operation mode, data is simultaneously written to the cache of the initiator subsystem and the cache of the target subsystems. The I/O completion status is not sent to the host until all members of the remote copy set are updated. Synchronous operation ensures the highest possible level of data consistency, which makes this process especially appropriate for business applications that require a high level of currency. The default setting is synchronous.

Asynchronous Operation Mode

In asynchronous operation mode, the write operation is reported to the host as complete *before* the data is written to the remote unit of the remote copy set. Asynchronous mode can provide improved response time, but the data on all members of the remote copy set cannot be assumed to be the same at all times.

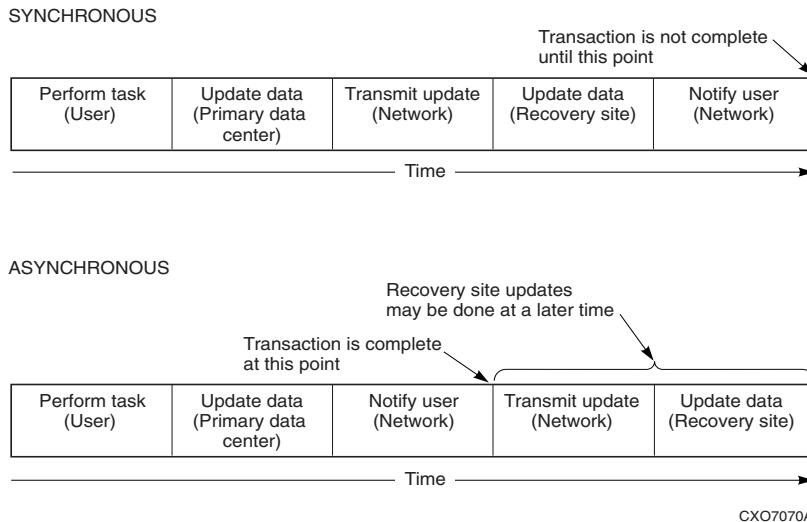

Figure 2–1: Remote copy set operation modes

Operation Mode Considerations

Consider the following characteristics when designing your DRM configuration:

- Synchronous replication is appropriate when exact consistency is critical to the business application. The application or application recovery depends upon data being written to both local and remote sites.
- The greater the Outstanding I/O setting, the more data can be lost when a disaster occurs at the initiator site. There is no loss of data in synchronous mode.
- Synchronous operation may deliver best response time for heavy host-write operations. In most cases, even though synchronous operation must wait for data to be sent to the target and the target to respond with acknowledgement, it is faster than asynchronous operation due to overhead in the controller when processing asynchronous commands.
- Asynchronous operation improves response time for some workloads.

ADD REMOTE_COPY_SETS Command

The ADD REMOTE_COPY_SETS *RemoteCopySetName InitiatorUnitName RemoteNodeNameTargetUnitName* command creates a remote copy set and starts a normalization copy to the target unit. During normalization, the controllers copy all data from the initiator unit to the target unit.

Outstanding_IO Settings

The OUTSTANDING_IO setting allows you to control the number of outstanding initiator-to-target writes for a remote copy set. It does not refer to the write queue depth between the host and the controller. This setting can be applied to both synchronous and asynchronous remote copy sets. However, this setting causes different behavior, depending on the remote copy set operation mode.

The default setting is 200 for each remote copy set. There is a shared maximum of 240 available to all remote copy sets on a controller.

Synchronous

For the synchronous operation mode, the OUTSTANDING_IO setting refers to the number of initiator-to-target writes that can be outstanding at any one time. If OUTSTANDING_IO is set to 1 and the host issues four writes to a remote copy set, then only one write is in progress between the initiator and target at a time. The other three writes are queued in the initiator controller. As each write completes at the target, another write is issued from the initiator controller write queue.

Asynchronous

For the asynchronous operation mode, the `OUTSTANDING_IO` setting applies to the number of non-committed host writes that can be outstanding at one time between the initiator and target. Non-committed means the write completion status has been returned to the initiator host, but the write has not been completed at the target.

Suppose, for example, that the outstanding I/O is set to 5 and that the host issues a request, waits for completion from the controller, then immediately issues another request. In asynchronous mode, each request issued by the host is completed by the controller very quickly. As a result, the host issues five requests before the remote site has completed the first request. If the host then issues another (sixth) request, it exceeds the value of the outstanding I/O.

Once you exceed the outstanding I/O value, the system switches to synchronous mode. As soon as an in-process I/O completes, another is started that attempts to empty the queue and return to true asynchronous operation.

Outstanding Write Operations

Keep in mind that there is a controller-wide limit of 240 outstanding write operations, even if the total number of writes is greater than 240. For example, you might have 12 synchronous remote copy sets, each with a value of 100. The maximum outstanding writes are 240, and not 1200. When 240 outstanding writes are reached, any new writes to the controller are queued on the host.

High Outstanding I/O Values

Use caution when choosing an `OUTSTANDING_IO` setting, since writes to the targets are handled on a FIFO (first in, first out) basis. As a result, remote copy sets with higher `OUTSTANDING_IO` values could potentially starve other remote copy sets if the write rates become very high.

Low Outstanding I/O Values

On the other hand, choosing a lower setting may starve a very active remote copy set. In the case of asynchronous remote copy sets, a lower `OUTSTANDING_IO` value may be appropriate. This lower value limits the number of outstanding non-committed writes in the event of an initiator site disaster.

Suspend and Resume Switches

The SUSPEND switch suspends the update to the remote copy set target and starts the write history logging of write commands and data from the unit.

NOTE: This switch is valid only in normal error mode with write history logging enabled (not failsafe).

The RESUME switch initiates the mini-merge restore of the specified remote target unit. This switch enables the initiator to read the log unit and send the write commands, in order, to the target, which brings the target into congruency with the initiator. For more information on mini-merge, see the “Write History Logging” section in this chapter.

NOTE: The SET *AssociationSetName* NOLOG_UNIT command terminates any suspended targets that are currently active.

Error Mode Switch

The following command sets the error mode condition:

```
SET RemoteCopySetName ERROR_MODE=FAILSAFE or  
SET RemoteCopySetName ERROR_MODE=NORMAL
```

The failsafe error mode causes a remote copy set to become failsafe locked if the target becomes inaccessible or the initiator unit fails. When failsafe is locked, the remote copy set is inaccessible.

If a dual link failure occurs, the target is not removed but is marked invalid. When the target is accessible again, a full copy operation is started. When the copy operation is completed, the failsafe locked condition is cleared.

If the error mode switch is set to NORMAL, write operations are allowed to continue even when a dual link or disk error is present. NORMAL is the default setting.

IMPORTANT: You cannot enable the failsafe switch with write history logging enabled.

Association Sets

An association set is a group of remote copy sets that share common attributes. Members of an association set can be configured to transition to the same state at the same time. For example, if one association set member assumes the failsafe locked condition, all other members of the same association set assume the failsafe locked condition as well.

An association set may also be used to simply share a write history log between a group of remote copy set members that require efficient use of the log space.

Association Set Characteristics

Things to remember about association sets include:

- Association sets can have up to 12 remote copy sets as members.
- Association sets can share a write history log, if enabled.
- Synchronous or asynchronous operation mode and members may be set differently.
- If ORDER_ALL is set, *in order* execution of commands across the remote copy sets in the association set is required.
- If FAIL_ALL is set and if one member assumes the failsafe locked condition, then all members of the association set assume the failsafe locked condition.
- Association sets reside on the initiator controller pair, as illustrated in Figure 2–2.

FAIL_ALL Switch

Because all copy sets within an association set are moved as a unit during failover and failback, all remote copy sets within an association set must be owned by the same server.

If the FAIL_ALL switch is enabled and one member of the association set assumes the failsafe locked condition, all members of the association set assume the failsafe locked condition. The failsafe locked condition prevents further host access.

IMPORTANT: This applies only to remote copy sets with failsafe error mode enabled. Failsafe error mode is enabled through the ERROR_MODE switch of the SET *RemoteCopySets* command.

When NOFAIL_ALL is specified, the members of the association set react independently to failsafe locked conditions. One member of the association set becoming failsafe locked has no effect on the other members of the association set. NOFAIL_ALL is the default setting.

The NOFAIL_ALL switch has no effect if all members of the association set have failsafe locked error mode disabled (normal error mode) or if there is only one remote copy set in the association.

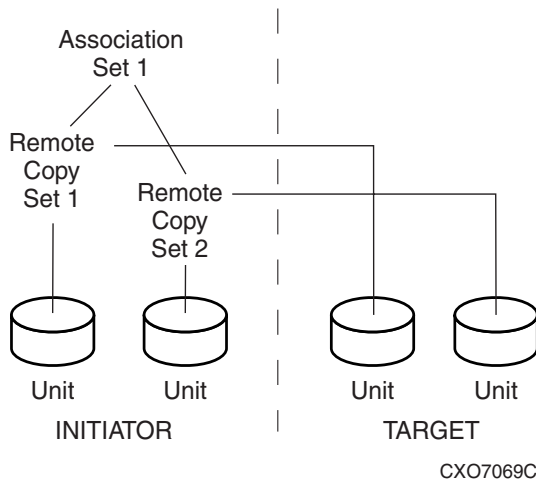

Figure 2-2: Location of association sets on the initiator controller pair

All members of an association set must be on the same controller, to enforce cache coherency. When members are added to an association set, they are moved to reside on the same controller; they failover together.

Association set members can be either synchronous or asynchronous. This allows for grouping only those members that use the same write history log unit.

ADD ASSOCIATIONS Command

When you issue the

```
ADD ASSOCIATIONS AssociationSetName RemoteCopySetName
```

command, it adds an association set with one member to the controller pair's configuration. Use this command on the node on which the initiator resides. Issue the

```
SET AssociationSetName ADD = RemoteCopySetName
```

command to add additional members.

Upon site failover, you must re-create the association sets and log units (see “Write History Log Unit Switches” on page 2-12) at the target (failover) site, using the attributes that were set at the initiator site.

Write History Logging

Write history logging means using a log unit to log a history of write commands and data from the host. The write history log serves two purposes: to update the target via a mini-merge when the ISL is temporarily broken and to update the initiator as part of the fast failback procedure. In either case, a full copy is not required.

Mini-Merge: When the target becomes accessible again after a failure, a full copy is not necessary. Only those host writes that were performed while the links were down are reissued. This is referred to as a *mini-merge*.

Fast-Failback: During a planned failover, if write history logging has been enabled at the target site, then when the failback is performed, the initiator site is synchronized through a process called *fast-failback*. The writes are logged to the target site write history log. Then, during a fast-failback, the initiator site is updated from the write history log.

If the target becomes inaccessible (because of a dual-target or dual-controller failure), the writes that would have gone to the target are logged to the association set's assigned write history log unit. An inaccessible target in this context refers to both links or target controllers going down.

Remote copy sets are marked for a full copy if they were actively performing write history logging or mini-merging at the time of the controller failure. If a full copy was in progress at the time of the disconnect, write history logging is not initiated and the full copy is restarted when the target is accessible again.

Following a planned failover, if write history logging was enabled at the target site, the initiator site is synchronized during the failback using fast-failback. In this scenario, writes destined for the initiator during the failover period are logged to the association set's write history log unit. This means that only those writes issued since the failover occurred are reissued; a full copy is not necessary.

Write History Log Units

Write history log units are assigned to an association set. Association sets are used by a host to keep multiple units consistent with each other. The write history log unit must always failover (between dual-redundant controllers) with the remote copy sets assigned to the same association set. *All members of the association set must reside on the same controller* and must failover both together and automatically. Upon site failover, the user must create a new write history log unit at the target site.

Write History Log Unit Restrictions

Things to remember about write history log units include:

- Up to 12 write history log units can be assigned (12 possible remote copy sets).
- There can be only one write history log unit assigned to an association set.
 - No new remote copy sets can be added to an association set while write history logging is active.
 - No new target can be added to a remote copy set that is part of an association set while write history logging is active.
- The write history log unit must be a mirrorset or a striped mirrorset.
- Host access must be disabled to create a write history log unit.
- Write-back caching must be disabled to create a write history log unit.
- Other unit settings must be the default settings to create a write history log unit.
- The write history log unit must reside at the current initiator site.
- Upon site failover, the write history log unit and association set must be reconfigured.
- The write history log unit cannot be a partitioned unit.
- The write history log unit must be a fixed size.

Reaching the End of a Write History Log Unit

Upon reaching the end of the write history log unit:

- The write history log unit is not wrapped and processing does not start over at the beginning. The write history log unit only resets to the beginning when it is empty.
- All active targets engaged in logging or mini-merging will require a full copy when the link is restored or when the RESUME command is issued.
- A full copy will occur when the target members are not removed from the remote copy sets.
- You can display a write history log unit utilization with SHOW REMOTE and VTDPY DISPLAY REMOTE commands.

The time required to reach the end of a write history log unit depends on several factors:

- Size of the write history log unit
- How long the link is down
- How long a target backup takes
- Host write workload
- Number of remote copy sets actively logging to the same unit

Write History Log Unit Performance Considerations

When the write history log unit is merging the captured write operations back to the target, the host makes all I/O resources available to the write history log unit. This means that you can expect at least a 90 percent reduction of host I/O capability for other operations. You must then consider whether the host can afford to perform the merge during normal high-activity hours, or whether the merge should take place during other non-active times, such as late evening.

A factor in this consideration is what other type of processing the host will be doing during the merge. If the host cannot afford such a drastic reduction in capability, you may wish to consider performing a full copy instead. During a full copy, the host will experience a less drastic I/O performance loss of approximately 50 percent.

The write history log unit function is primarily intended for, and is most efficient with, short duration outages. If a long duration outage is planned, the full copy option may be the best solution.

Write History Log Unit Size Considerations

Choose the size of the write history log unit carefully. When the end of the write history log unit is encountered, a full copy is initiated when the link is restored. You may wish to select a write history log unit size that will accommodate a maximum outage of 8 hours duration, with the merge occurring during the non-peak hours that same day.

Display the write history log status by issuing the following CLI command:

```
SHOW REMOTE_COPY FULL
```

Switches

This section discusses the write history log, order_all, suspend, and resume switches.

Write History Log Unit Switches

The LOG_UNIT switch of the ADD ASSOCIATIONS command assigns a single, dedicated write history log unit for an association set.

NOTE: This switch is valid only if all members of the association set are in normal (not failsafe) error mode. Error mode is determined by the ERROR_MODE switch of the SET *RemoteCopySet* command.

IMPORTANT: When this command is entered, a header is immediately written to the write history log unit, which may make it difficult or impossible to recover any user data previously written on the unit. Take great care when you specify which unit should be the log unit.

If NOLOG_UNIT is specified, the association set's write history log unit is de-assigned. NOLOG_UNIT is the default setting.

NOTE: A full copy occurs if you disable write history logging after logging operations have begun.

ORDER_ALL Switch

When the ORDER_ALL switch of the ADD ASSOCIATIONS command is enabled, the order of all asynchronous write operations across all members of the association set is preserved. No write history log unit is required.

With the ORDER_ALL switch enabled and write history logging enabled, if one member of the association set starts write history logging, all members of the association set start write history logging. This allows the mini-merge to replay the writes in the same order received from the host.

If NOORDER_ALL is enabled, the members of the association set can start and finish write history independently. NOORDER_ALL is the default setting.

SUSPEND

The SUSPEND switch of the SET *remote-copy-set-name* CLI command allows suspension of write operations to the target so that the target can be used for backup. This switch starts the write history log process for the specified target.

This command is issued at the initiator site, even though the backup is occurring at the target site.

RESUME

The RESUME switch of the SET *remote-copy-set-name* CLI command allows resumption of write operations to the target. The SUSPEND command must previously have been entered for this command to be valid.

This command starts the mini-merge process for restoration of the specified remote target unit.

Failover

There are two types of failover:

- Planned failover (due to a planned takedown of one of the systems; to perform maintenance, for example).
- Unplanned failover (due to a failure within the DRM system).

For more detail on failover and failback, refer to the *SANworks Data Replication Manager by Compaq HSG80 Version 8.6-4P Failover/Failback Procedures Guide*.

Planned Failover

A planned failover allows for an orderly shutdown of controllers. The host applications are quiesced and all write operations are permitted to complete before shutting down the controllers, so that no data is lost or jeopardized. A planned failover requires a synchronous operation mode.

NOTE: To implement a planned failover while in asynchronous operation mode, you must first switch to synchronous operation.

Unplanned Failover

An unplanned failover does not allow for an orderly shutdown of controllers. An unplanned failover is initiated when any of the following occurs:

- The initiator site is lost.
- There is no host access.
- There is no access to both initiator controllers.

NOTE: If both links are severed and the initiator configuration is functional, the system administrator must determine which site to use as the primary site.

Failback

The failback method (full copy or fast-failback) is determined by the enabling of logging or failsafe switches, the selected operation mode, and whether the failover is planned or unplanned, as specified in Table 2–1. This table also shows the availability of the association set switches, ORDER_ALL and FAIL_ALL.

For more detail on failover and failback, refer to the *SANworks Data Replication Manager by Compaq HSG80 Version 8.6-4P Failover/Failback Procedures Guide*.

Table 2–1: Controller Option Settings for DRM

Logging Enabled					Association Sets	
Logging	Error Mode Failsafe	Operation Mode	Failover	Failback	Order All	Fail All
Enabled	Disabled	Synchronous	Planned	Fast-Failback	Settable	Not Applicable for DRM
Enabled	Disabled	Synchronous	Unplanned	Full Copy	Settable	Not Applicable for DRM
Enabled	Disabled	Asynchronous (switch to Synchronous)	Planned	Fast-Failback	Settable	Not Applicable for DRM
Enabled	Disabled	Asynchronous	Unplanned	Full Copy	Settable	Not Applicable for DRM

NOTE: Logging is recommended for operations that can tolerate temporary loss of currency at the target site.

Table 2–1: Controller Option Settings for DRM (Continued)

Failsafe Enabled					Association Sets	
Logging	Error Mode Failsafe	Operation Mode	Failover	Failback	Order All	Fail All
Disabled	Enabled	Synchronous	Planned	Full Copy	Not Applicable for DRM	Settable
Disabled	Enabled	Synchronous	Unplanned	Full Copy	Not Applicable for DRM	Settable
Disabled	Enabled	Asynchronous	Planned	Full Copy	Settable	Settable
Disabled	Enabled	Asynchronous	Unplanned	Full Copy	Settable	Settable
NOTE: Failsafe is recommended for operations that can tolerate application halt during temporary target inaccessibility.						
Logging and Failsafe both Disabled: Not recommended. Not disaster tolerant						
Logging and Failsafe both Enabled: Not permitted. Logging and failsafe may not be enabled simultaneously.						

Getting Started

This chapter explains how to get your Data Replication Manager (DRM) solution ready for setup.

NOTE: It is a good idea to keep a copy of this manual at both the initiator and target sites to ensure a successful and identical setup at both sites. Two copies also eliminate confusion if more than one person is configuring DRM.

This chapter covers the following topics:

- “Site, Host, and Solution Preparation” on page 3–1
 - “Host Bus Adapter Requirements” on page 3–2
 - “Setting Up the Fibre Channel Switches” on page 3–3
 - “Setting Up the Fiber Optic Cables” on page 3–4
- “Cascaded Switches” on page 3–6
 - “Hopping” on page 3–7
 - “Cascaded Switch Configurations” on page 3–7
- “Multiple Intersite Links” on page 3–10

Site, Host, and Solution Preparation

Before you start operating your disaster tolerant (DT) subsystem, you must:

- Ensure that you have sufficient space to install and store the subsystems and have adequate power and cooling resources.
- If you choose to use more than one rack, understand the proper methods for positioning and joining subsystems.
- Have the proper devices installed.
- Verify that all of the storage components are in place.

To learn more about adding additional storage, refer to the documents listed in Table 3–1.

Table 3–1: Platform-Specific Rack Documentation

- Compaq StorageWorks HSG80 ACS Solution Software Version 8.6 for Compaq OpenVMS Installation and Configuration Guide
- Compaq StorageWorks HSG80 ACS Solution Software Version 8.6 for Compaq Tru64 UNIX Installation and Configuration Guide
- Compaq StorageWorks HSG80 ACS Solution Software Version 8.6 for HP-UX Installation and Configuration Guide
- Compaq StorageWorks HSG80 ACS Solution Software Version 8.6 for IBM AIX Installation and Configuration Guide
- Compaq StorageWorks HSG80 ACS Solution Software Version 8.6 for Novell NetWare Installation and Configuration Guide
- Compaq StorageWorks HSG80 ACS Solution Software Version 8.6 for Sun Solaris Installation and Configuration Guide
- Compaq StorageWorks HSG80 ACS Solution Software Version 8.6 for Windows NT and Windows 2000 Installation and Configuration Guide
- Compaq StorageWorks EMA16000 System Rack User Guide

Host Bus Adapter Requirements

To run your DRM solution, you must have two host bus adapters (HBAs) installed on your host system. For detailed information on this hardware, refer to the HBA's user guide that came with your adapter.

At this time, it is important to locate and record the World Wide Names (WWNs) of each HBA. For the HBA at the target site, you can record the WWN in the worksheet provided in Chapter 4, "Configuring a Standard Data Replication Manager Solution." The initiator site HBA WWNs can also be recorded in the worksheet in Figure 4–4 in Chapter 4. You must have this number handy when you rename the host connections in Chapter 4.

NOTE: The World Wide Name can be found on the bottom of the HBA board. Look for a small bar code label with an IEEE (Institute of Electrical and Electronics Engineers) precursor. A WWN example is 1000-0000-C920-A5BA.

Setting Up the Fibre Channel Switches

The Fibre Channel switches must be in place before the DRM subsystems can be cabled and configured. You need the following to install your Fibre Channel switches:

- Power cord
- 10BASE-T cable with RJ45 plug (to be connected to an Ethernet hub or switch)
- Fixed IP address and subnet mask (one of each per switch)

The Ethernet cable and IP address are required to monitor and administer the Fibre Channel switch. Configure the Ethernet IP address and the Ethernet IP subnet mask with the front panel buttons of the Fibre Channel switch (16-port switches only). Refer to the *Compaq StorageWorks Fibre Channel Storage Switch User's Guide* for more details.

Once the Ethernet IP settings are established, perform the following steps:

1. *Ping* the switch using the Ethernet IP address of the switch. If this is successful, you have access to the switch.
 2. *Ping* using the name of the switch. This verifies the operation of the name resolution.
 3. *Telnet* into the switch (username = “admin”; password = “password” [default setting]). Refer to the *Compaq StorageWorks Fibre Channel SAN Switch Management Guide* for Telnet session procedures. Make the following adjustments to the switch:
 - Enter `switchName` to configure the switch name. Be sure to designate a name that enables you to easily identify the switch you are trying to access.
Example: switchName NewSwitchName
 - Enter `switchShow` to reveal the status of the switch and some of its ports.
 - Enter `version` to display the firmware levels. For updated version information, go to the DRM website:
<http://www.compaq.com/products/sanworks/drm/index.html>
- Follow the Software Support Matrices link, then choose your operating system.
4. Using a Java-capable browser, go to <http://<FC switch DNS name>> to view a visual representation of the switch. (You need to know the Domain Server Name.) You can double-click on this picture for further information.

Setting Up the Fiber Optic Cables

Before you connect the fiber optic cables to your subsystems, it is important to understand the designated names of each component. See Table 3–2 on page 3–6 for an overview list of required connections for each site and between the sites.

NOTE: For instructions on making connections, refer to Chapter 4, “Configuring a Standard Data Replication Manager Solution.”

Figure 3–1 shows how each component is referenced in this document.

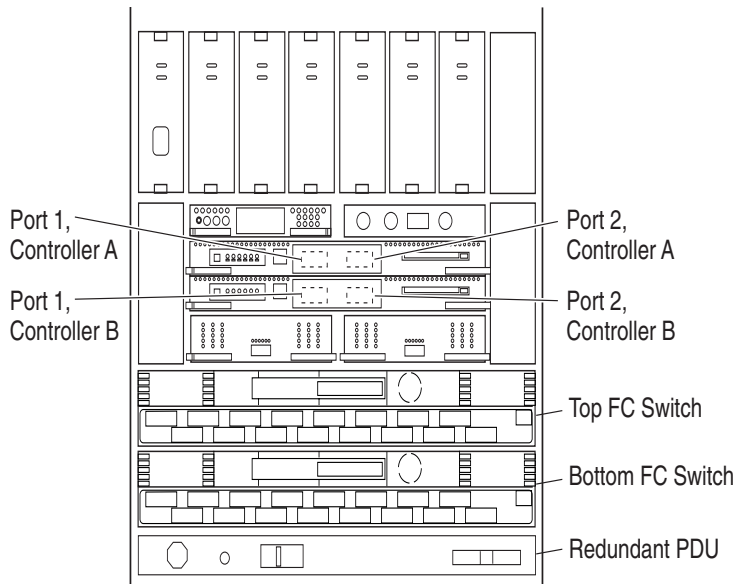

CXO7096A

Figure 3–1: Locations and names of components for connecting fiber optic lines

Before you connect the fiber optic cables, Compaq recommends that you tag each end of the cables with the following information.

Host-to-Switch Connections

- Host name and rank number or PCI slot number of the HBA
- Switch name and port number on switch

Switch-to-Controller Connections

- Fibre Channel switch name (top or bottom)
- Fibre Channel switch port number (0-15)
- Site name (initiator or target)
- Controller name
- Controller port number (1 or 2)
- Host port number
- HBA WWN

The DT solution requires two different types of fiber optic cables, depending on where the connections are made. Cabling at each individual site that involves the controller, the switch, and the host is made with 50-micron multi-mode fiber optic cables. The maximum length that these cables support is 500 meters. When cabling between initiator and target sites that are more than 500 meters apart using GBICs, you must use a 9-micron single-mode fiber optic cable, which can run a distance of up to 100 km, depending on the GBIC and the quality of the cable connection. For additional information refer to the *Compaq SANworks Data Replication Manager Using Very Long Distance GBICs Application Note*.

NOTE: The 9-micron single-mode fiber optic cable may also be referenced by some manufacturers as an 8.3-micron cable. To increase the reliability of the cable or to reduce the likelihood of having to re-pull or re-install the cable over a long distance, Compaq recommends that you use multiple conductor cable.

For a list of the most current software, firmware, patches, drivers, and so on, for each of the supported operating systems in your DRM solution, go to the following website:

<http://www.compaq.com/products/sanworks/drm/index.html>

Follow the Software Support Matrices link, then choose your operating system.



CAUTION: If the Fibre Channel cable is not properly connected to the controller, failure may result. Because of the cable's frail nature, it must be regularly maintained or its performance and life span will be affected. Before continuing, make sure that you follow the precautions listed in the *Compaq StorageWorks HSG80 Array Controller ACS Version 8.6 Maintenance and Service Guide*.

Table 3–2 provides an example of the connections required at each site and between the sites for the first server and first storage array. Note that additional servers and additional arrays will use other ports. Specific connection information is covered in more detail in Chapter 4, “Configuring a Standard Data Replication Manager Solution.”



CAUTION: Do not make any connections until you are instructed to do so later in this guide.

Table 3–2: Example of Wiring for First Server and First Storage Array at Each Site

Initiator Site		Target Site	
Host Port 1	→ Top Switch, Port 0	Host Port 1	→ Top Switch, Port 0
Host Port 2	→ Bottom Switch, Port 0	Host Port 2	→ Bottom Switch, Port 0
Controller A, Port 1	→ Top Switch, Port 2	Controller A, Port 1	→ Top Switch, Port 2
Controller A, Port 2	→ Top Switch, Port 4	Controller A, Port 2	→ Top Switch, Port 4
Controller B, Port 1	→ Bottom Switch, Port 2	Controller B, Port 1	→ Bottom Switch, Port 2
Controller B, Port 2	→ Bottom Switch, Port 4	Controller B, Port 2	→ Bottom Switch, Port 4

Between Initiator and Target Site			
Top Switch, Port 6	→	External Fiber Link	← Top Switch, Port 6
Bottom Switch, Port 6	→	External Fiber Link	← Bottom switch, Port 6

Note that additional servers and storage arrays will use other ports.

Cascaded Switches

Cascaded switches provide a DRM configuration variation that lets you:

- Increase the distance between sites (expand the fabric)
- Increase host or controller port connections

A *cascaded switch* is one where the output of one switch is connected to the input of another. The second switch may then be connected to another switch, a host, or a controller.

Hopping

The cascading of switches employs hopping. A *hop* is defined as one or more connections between two Fibre Channel switches. Two switches cascaded are equal to one hop. Server-to-Fibre-Channel switch segments and storage-to-Fibre-Channel switch segments are not counted as hops.

The definitive resource for SAN configuration rules is the *Compaq StorageWorks Heterogeneous Open SAN Design Reference Guide*, which is available at the following website:

<http://www.compaq.com/products/storageworks/san/documentation.html>

The rules that apply to hops in a DRM environment:

- No more than seven hops are allowed from the initiator controller to the target controller.
- No more than seven hops are allowed from a host to either the initiator or target controller.
- Within a single fabric where switches are interconnected, each Fibre Channel switch must have a unique domain number (Domain_ID).
- The maximum distance allowed using short wavelength laser GBICs and 50-micron multi-mode fiber optic cable is 500 meters per cable segment.
- The maximum distance allowed using long wavelength laser GBICs and 9-micron single-mode fiber optic cable is 10 kilometers per cable segment.
- Very Long Distance GBICs can extend ISLs up to 100 kilometers.
- Wave-Length Division Multiplexing (WDM) can extend up to 120 kilometers.
- Only one extended long wavelength ISL is allowed per fabric.
- Cascaded switches are not supported in asynchronous transfer mode (ATM) configurations.

Cascaded Switch Configurations

Figure 3–2 shows a DRM configuration that increases the distance between sites by using cascaded switches and hopping. There are no hops from the initiator host to the initiator controller and three hops from the initiator host to the target controller. There are four Fibre Channel cascaded switches with no hops from the host and three hops to controller pair 2. Hop 1 spans the shortest distance (500 meters), hop 2 spans 10 kilometers, and hop 3 spans the longest distance, 100 kilometers.

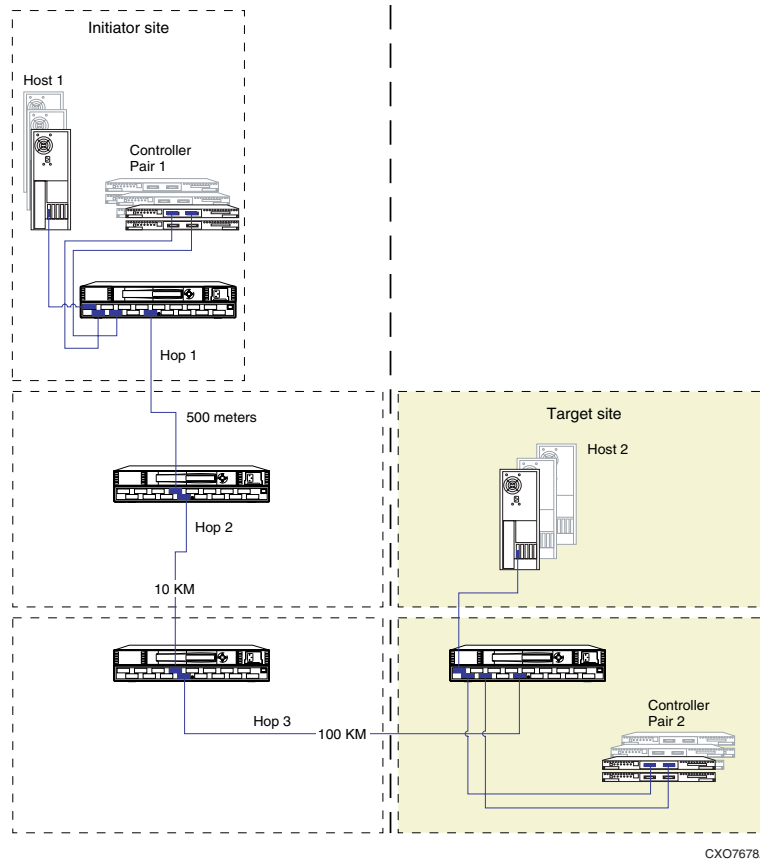
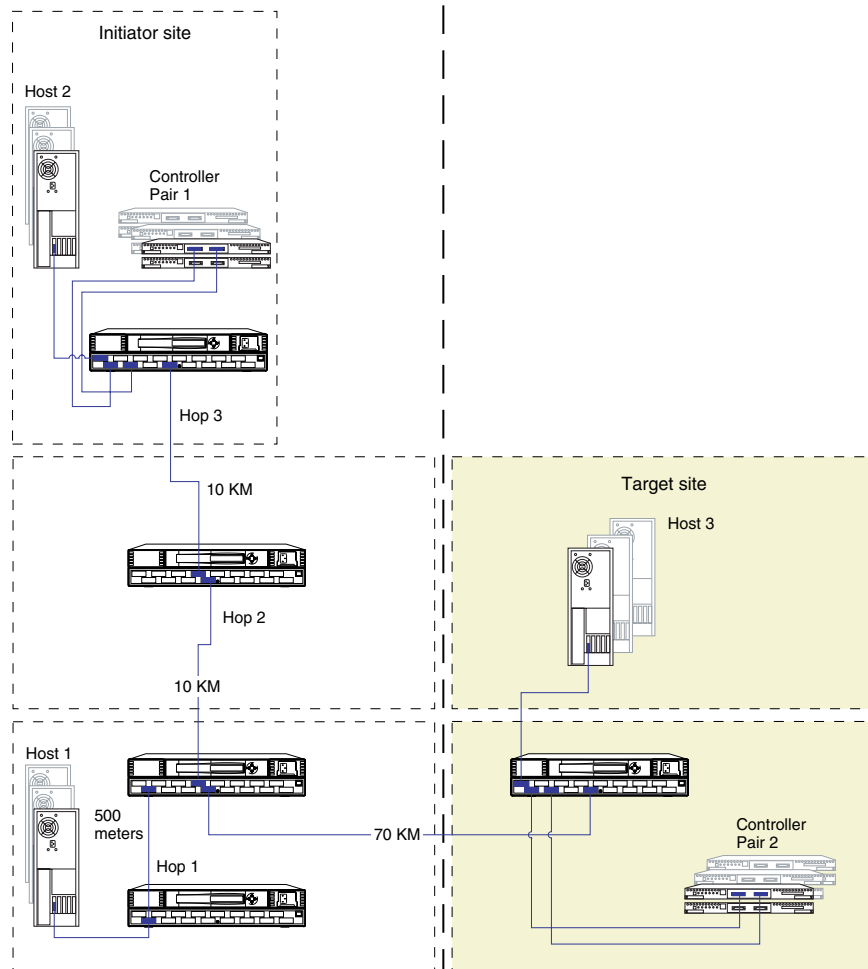

Figure 3–2: Cascaded switches in a DRM environment



CX07291A

Figure 3–3: Cascaded switches in DRM environment with three hops between host and controller

Figure 3–3 shows a DRM configuration that increases the number of host-to-controller port connections using cascaded switches and hopping. The figure features switches cascaded from Host 1 to the initiator controller. There are four Fibre Channel cascaded switches, three hops from Host 1, and three hops to the initiator controller pair 1.

Multiple Intersite Links

Multiple intersite links (ISLs) provide additional bandwidth between local and remote sites. Each ISL is a fiber link between two switches.

The restrictions that apply when using multiple ISLs in a DRM environment are listed below:

- DRM supports a maximum of two ISL connections per fabric.
- The Multiple E-port Connectivity software option is required to access more than one E-port when using multiple ISLs or interswitch links with the SAN Switch 8-EL.
- For a Cascaded Switch configuration, the SAN switch 8-EL must be placed at the end of the cascade to provide access to the E-port, unless the Multiple E-port Connectivity software option is used.

You can increase bandwidth on the ISL by adding an additional link in parallel between the same two switches, as shown in Figure 3–4. DRM supports two connections, maximum. The switches are shown as physically connected, although the connections are transparent to the fabric. Functionally, the devices appear to be connected directly together.

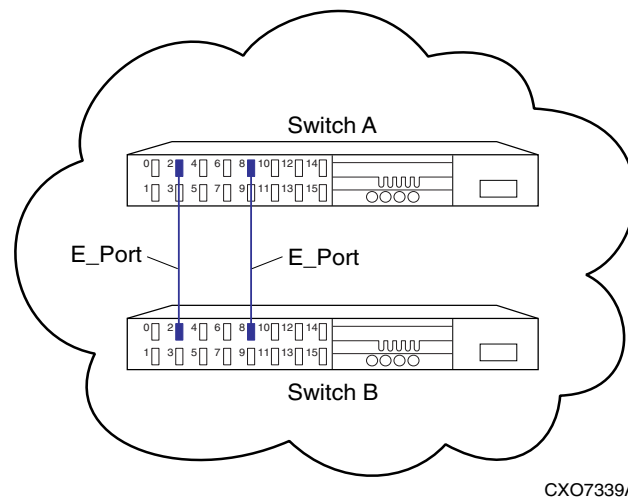

Figure 3–4: Multiple intersite links

Configuring a Standard Data Replication Manager Solution

This chapter provides procedures for configuring your Data Replication Manager (DRM) solution. Since a DRM system spans two sites, you must configure the DRM system at each site.

These procedures take you through the configuration process. You will first set up the target site, then the initiator site. Setup for each site is similar. At each site, you will configure the controllers by defining controller characteristics specific to DRM. You will then define storagesets, units, remote copy sets, and association sets. After the controllers are configured, you will make fiber optic cable connections between the controllers and switches. Finally, you will install the necessary software and drivers on each host.

This chapter covers the following topics:

- “Introduction” on page 4–2
- “Configuration Overview” on page 4–6
- “Configure the Controllers at the Target Site” on page 4–8
- “Configure Storage at the Target Site” on page 4–16
- “Cable the Target Site” on page 4–19
- “Create Switch Zones at the Target Site” on page 4–22
- “Configure the Host at the Target Site” on page 4–23
- “Configure the Controllers at the Initiator Site” on page 4–56
- “Configure Storage at the Initiator Site” on page 4–63
- “Cable the Initiator Site” on page 4–66
- “Connect the Initiator Site to the External Fiber Link” on page 4–68
- “Create Switch Zones” on page 4–69
 - “Create Connections from the Target Site” on page 4–70

- “Create Write History Log Units and Association Sets (Optional)” on page 4–73
- “Configure the Host at the Initiator Site” on page 4–77
- “Additional Host Configuration” on page 4–111
- “Documenting Your Configuration” on page 4–111

Introduction

The disaster tolerant (DT) configuration that supports DRM requires two HSG80 Array Controller subsystems—one at an initiator site and one at a target site.

IMPORTANT: Because of the complexity of the configuration process, it is a good idea to have all DRM documentation available at both sites to eliminate confusion and minimize the risk of error. Follow the steps precisely in the order provided in this document.

Figure 4–1 shows a basic DRM configuration; it is referenced throughout this chapter.

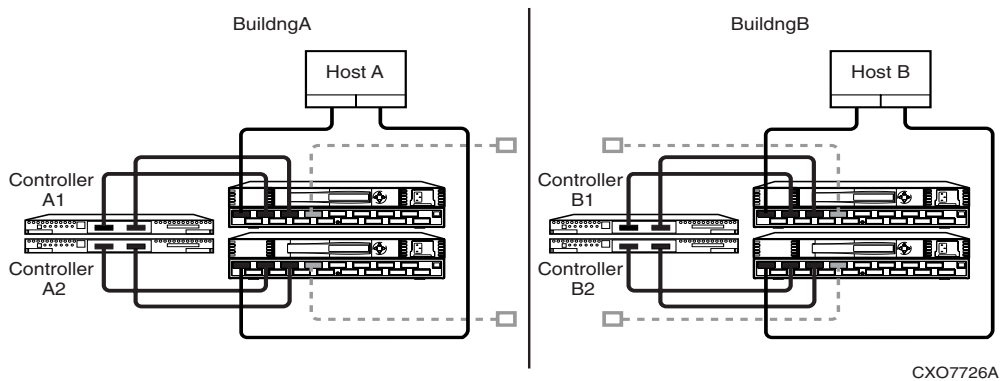

Figure 4–1: Data Replication Manager basic configuration

Restrictions

It is important to understand the operating restrictions before configuring your DRM solution. Table 4–1 lists points to consider before proceeding to the configuration process.

Table 4–1: Restrictions

Restriction	Comments
Two HSG80 controller pairs are required.	All controllers must run ACS V8.6-4P. HSG60 controller pairs are not supported.
Four Fibre Channel switches are required. (The entry-level DRM configurations introduced in Chapter 5 are exceptions to this restriction).	These switches provide two separate fabrics connecting controllers at the initiator and target sites.
HSG80 controllers can be configured for Fibre Channel switched protocol and SCSI-2 or SCSI-3 protocol.	<ul style="list-style-type: none"> • AIX and Solaris host operating systems and adapters must support Fibre Channel switched protocol and SCSI-2 protocol. • Compaq OpenVMS host operating systems and adapters must support Fibre Channel switched protocol and SCSI-3 protocol • Except for AIX, Solaris, and OpenVMS, the host operating systems and adapters must support Fibre Channel switched protocol and SCSI-2 or SCSI-3 protocol.
Mirrored write-back cache must be enabled.	Requires 512 MB cache per controller (256 MB effective capacity once mirrored).
Maximum configuration for all platforms except NetWare: <ul style="list-style-type: none"> • 12 equivalent hosts per storage array • 6 host bus adapters (HBAs) per host • 24 units per host • 8 subsystems per site 	There must be least two HBAs per server; refer to the OS-dependent restrictions in the <i>Heterogeneous OpenSAN Design Reference Guide</i> .
Maximum configuration for NetWare: <ul style="list-style-type: none"> • 4 HBAs per host 	2 HBAs per host minimum.
For AIX, there is a maximum of 15 LUNs per storage array.	LUNs 1 to 15 are available; LUN 0 is the Command Console LUN (CCL).
Maximum of 12 remote copy sets allowed per HSG80 controller pair.	If more than 12 remote copy sets are needed, additional subsystems are required.

Table 4–1: Restrictions (Continued)

Restriction	Comments
Maximum of 2 unit members allowed per remote copy set.	Composed of 1 initiator unit and 1 target unit.
Target unit cannot reside on the same controller pair as its initiator unit.	One controller pair required for initiator; one controller pair required for target.
Controller replication conducted through port 2 on each controller.	<ul style="list-style-type: none"> • Link between initiator and target site is made through Port 2. • Both port 2 links (top and bottom controllers) must be up when DRM setup is configured.
Maximum of 96 connections.	Effective number of connections is 96 minus the 4 default remote copy connections. More than 96 connections may require use of switch zoning to restrict visible devices.
It is not possible to run DILX (disk inline exerciser) on units used by remote copy sets.	Run DILX prior to creating the remote copy set configuration. For information on DILX, refer to the Glossary and the <i>Compaq StorageWorks HSG80 Array Controller ACS Version 8.6 CLI Reference Guide</i> .
The LUN/unit at the initiator and target sites must be identical.	Keep the unit number, RAID level, disk geometry used, and other parameters the same to eliminate confusion and risk of error.
Controller-based partitions are not supported within remote copy sets.	Host software may be capable of partitioning units.
Units at the initiator and target sites cannot be transportable units.	Units cannot be moved to non-controller configurations without potential data loss.
Cannot use FRUTIL on remote site while I/O is in progress to target site.	For information on FRUTIL, see the <i>Compaq StorageWorks HSG80 Array Controller ACS Version 8.6 CLI Reference Guide</i> .

Table 4–1: Restrictions (Continued)

Restriction	Comments
<p>Write history log units must:</p> <ul style="list-style-type: none"> • Reside at the initiator site • Not be moved to the target site • Not be a partitioned unit • Have mirrored write-back cache disabled • Have all access disabled • Be re-created at target site after failover • Be a mirrorset 	<p>Can be a 1-member mirrorset</p>
<p>Maximum of 12 non-remote copy set LUNs at initiator and target sites.</p>	
<p>Compaq Storage Arrays running ACS 8.5F, 8.5S, 8.5P, 8.6F, and 8.6S may co-exist on the same SAN with a DRM configuration using ACS 8.6P.</p>	
<p>For OpenVMS, the LP7000 and LP8000 HBAs may coexist on the same DRM storage area network. However, they may not share the same server. AIX supports only Cambex HBAs.</p>	
<p>Zoning is required when there is more than one Tru64 TruCluster. See Chapter 6, “Configuring the Optional Advanced DRM Solutions,” and the <i>Heterogeneous Open SAN Design Reference Guide</i> for details on switch zoning.</p>	
<p>Boot disks on HSG80 for OpenVMS must be non-remote copy set devices.</p>	
<p>DRM does not support the bootless failover of the system disk by any of the supported operating systems.</p>	

For a list of additional software support required for each operating system in your DRM solution, visit the following website:

<http://www.compaq.com/products/sanworks/drm/index.html>

Follow the Software Support Matrices link, then choose your operating system.

Configuration Overview

Both the initiator and target sites need a command line interface (CLI) to the controller. You can connect the serial maintenance port of both the initiator and target site controllers to a terminal supporting multiple serial connections, or to multiple terminals, from which to issue CLI commands. You can also start a terminal emulator session from the platform of your choice (for example, HyperTerminal in Windows). The default settings are 9600 baud, 8 bits, no parity, 1 stop bit.

Terminal emulator sessions require either a direct serial connect from the server to the controller, or an intermediate terminal server. If you use a terminal server, the connection from the server running the emulator to the terminal server will be over a standard network, not a serial connection.

Configuration Procedures Outline

NOTE: In this chapter, target site procedure steps are marked with a target symbol, . Initiator site procedures are marked with an initiator symbol, .

Target Site Outline

- Configure the Controllers at the Target Site
- Configure Storage at the Target Site
 - Devices and Stagesets
 - Create Storage Units
- Cable the Target Site
 - Connect Fiber Optic Cables Between Controllers and Fibre Channel Switches
 - Connect the Target Site to the External Fiber Link
- Create Switch Zones at the Target Site
- Configure the Host at the Target Site
 - Compaq OpenVMS

- Compaq Tru64 UNIX
- HP-UX
- IBM AIX
- Microsoft Windows NT and Windows 2000
- Novell NetWare
- Sun Solaris

Each of these steps is specified in detail in the sections beginning on page 4–8.



Initiator Site Outline

- Configure the Controllers at the Initiator Site
- Configure Storage at the Initiator Site
 - Devices and Stagesets
 - Create Storage Units
- Cable the Initiator Site
 - Connect Fiber Optic Cables Between Controllers and Fibre Channel Switches
- Connect the Initiator Site to the External Fiber Link
- Create Switch Zones
- Create Remote Copy Sets
 - Prepare the Initiator Site
 - Create Connections from the Target Site
 - Create Remote Copy Sets from the Initiator Site
 - Set Failsafe at the Initiator Site (Optional)
- Create Write History Log Units and Association Sets (Optional)
 - Create a Write History Log Unit
 - Create Association Sets and Assign a Write History Log Unit
- Configure the Host at the Initiator Site
 - Compaq OpenVMS
 - Compaq Tru64 UNIX



- HP-UX
- IBM AIX
- Microsoft Windows NT and Windows 2000
- Novell NetWare
- Sun Solaris

Each of these steps is specified in detail in the sections beginning on page 4–56.

Configure the Controllers at the Target Site

NOTE: Target site procedure steps are marked with a target symbol, . Initiator site procedures are marked with an initiator symbol, .





Before configuring the controllers at the target site, follow these preparatory steps:

-  1. Identify the World Wide Name (WWN) on the HBAs in each host.
-  2. Establish the names to assign to the target and initiator sites. Use a naming convention that is meaningful, like building or city names; for example, name the initiator site *BuildngA* and target site *BuildngB*.

NOTE: These names may be a maximum of nine characters. They may consist of alphanumeric characters and special characters, except for the comma (,) and backslash (\).

NOTE: If you use scripting to automate failover and failback operations, do not use dashes (hyphens) as separators in your naming convention—use underscores instead. Dashes are not allowed by the Perl scripting language.

To get your DT system up and running, you must set up and configure the controllers. These tasks are outlined in the following procedure:

-  1. Ensure that all enclosures, Fibre Channel switches, and power distribution units (PDUs) are powered off.
-  2. Plug all rack PDU power cords into the main power receptacles.
-  3. Make sure that you have a serial connection ready to the maintenance port of each controller. Refer to the *Compaq StorageWorks HSG80 Array Controller ACS V8.6 Maintenance and Service Guide* for instructions.
-  4. Power on all PDUs.
-  5. Ensure that the Fibre Channel switches are powered on, but not cabled.

NOTE: When the enclosures are turned on, the controllers start only if the PCMCIA cards are already installed. If there are no cards in the controller slots, insert them now and press the **Reset** button. Refer to the *Compaq StorageWorks HSG80 Array Controller ACS V8.6 Maintenance and Service Guide* for complete instructions on properly seating the controller firmware cards.

6. Turn on the enclosures.
7. Establish a CLI connection to the bottom controller. Refer to the *Compaq StorageWorks HSG80 Array Controller ACS V8.6 Maintenance and Service Guide* for instructions.
8. Verify that the bottom controller is on and functional by looking for the CLI prompt on the maintenance port.
9. Establish a CLI connection to the top controller.
10. Verify that the top controller is on and functional by looking for the CLI prompt on the maintenance port.

NOTE: Unless otherwise noted, all operations may be conducted from the top controller (controller B1).

11. To verify that the controllers are properly set up, issue the CLI command:

```
SHOW THIS_CONTROLLER
```

You should see a display similar to that in Example Display 1.

Example Display 1

Controller:

```
HSG80 ZG8nnnnnnn Software V86P-4, Hardware E03
NODE_ID           = nnnn-nnnn-nnnn-nnnn
ALLOCATION_CLASS = 0
SCSI_VERSION      = SCSI-2
Not configured for dual-redundancy
Controller misconfigured -- other controller present
Device Port SCSI address 7
Time: NOT SET
Command Console LUN is disabled
```

Host PORT_1:

```
Reported PORT_ID = nnnn-nnnn-nnnn-nnnn
```

```
PORT_1_TOPOLOGY = OFFLINE (offline)
Host PORT_2:
  Reported PORT_ID = nnnn-nnnn-nnnn-nnnn
  PORT_2_TOPOLOGY = OFFLINE (offline)
  NOREMOTE_COPY
Cache:
  512 megabyte write cache, version 0012
  Cache is GOOD
  No unflushed data in cache
  CACHE_FLUSH_TIMER = DEFAULT (10 seconds)
Mirrored Cache:
  Not enabled
Battery:
  FULLY CHARGED
  Expires: . . . . .
  NOCACHE_UPS
```

12. Verify that the subsystem WWN (also called the *NODE_ID*) has been assigned to the controller. If zeros are displayed, the name is not set.
- If the name is set, go to step 15.
 - If the WWN has not been assigned to the controller, you must obtain the name and set it before proceeding.

NOTE: The subsystem's WWN and checksum are located on a sticker on top of the frame that houses the controllers, EMU, PVA, and cache modules. The checksum is required to verify that the WWN is valid. If there is no label on the frame, contact your Compaq customer service representative for assistance. Refer to Chapter 7 for more information on WWNs. Each subsystem's WWN begins with 5000 and ends with a zero; for example, 5000-1FE1-FF0C-EE00. The controller port IDs are derived from the WWN.



CAUTION: Never set two subsystems to the same WWN; data corruption will occur.

13. After the WWN has been located (in step 12), assign it to the controller:

```
SET THIS_CONTROLLER NODE_ID=node_ID checksum
```

You should see a display similar to that in Example Display 2.

Example Display 2

```
Warning 4000: A restart of this controller is required before all the
  parameters modified will take effect
%CER--HSG80> --09-FEB-1999 10:07:54-- Restart of this controller required
Restart of this controller required
```

NOTE: Do not restart the controller until the procedure instructs you to do so.

- ④ 14. Issue a SHOW THIS_CONTROLLER command to verify that the WWN has been set.
You should see a display similar to that in Example Display 3.

Example Display 3

Controller:

```
HSG80 ZG8nnnnnnn Software V86P-4, Hardware E03
NODE_ID           = YYYY-YYYY-YYYY-YYYY
ALLOCATION_CLASS = 0
SCSI_VERSION     = SCSI-2
Not configured for dual-redundancy
  Controller misconfigured -- other controller present
Device Port SCSI address 7
Time: NOT SET
Command Console LUN is lun 0 (NOIDENTIFIER)
.
.
.
```

- ④ 15. Configure the controllers for multiple-bus failover mode:

```
SET MULTIBUS_FAILOVER COPY = THIS_CONTROLLER
```

This command automatically restarts the “other” controller.

You should see %LFL and %EVL prompts. Refer to the *Compaq StorageWorks HSG80 Array Controller ACS V8.6 Maintenance and Service Guide* for more information on these reports.

- ④ 16. To ensure that the setting from step 15 has been applied, issue the command:

```
SHOW OTHER_CONTROLLER FULL
```

Check the display to verify that the controllers have been configured to support multiple-bus failover mode. You should see a display similar to that in Example Display 4.

Example Display 4

Controller:

```
HSG80 ZG8nnnnnnn Software V86P-4, Hardware E03
NODE_ID          = nnnn-nnnn-nnnn-nnnn
ALLOCATION_CLASS = 0
SCSI_VERSION     = SCSI-2
Configured for MULTIBUS_FAILOVER with ZG8nnnnnnn
In dual-redundant configuration
Device Port SCSI address 7
Time: NOT SET
Command Console LUN is lun 0 (NOIDENTIFIER)
.
.
.
```

NOTE: These settings are applied automatically to the bottom controller (controller B2). It is not necessary to repeat these steps on controller B2.

- ④ 17. You must select the SCSI mode for the subsystem. Some operating systems support only one SCSI mode. For more information, go to the DRM website:

<http://www.compaq.com/products/sanworks/drm/index.html>

Follow the Software Support Matrices link, then choose your operating system.

- a. To set SCSI-3 mode:

```
SET THIS SCSI = SCSI-3
```

NOTE: For OpenVMS, set allocation class and identifier:

```
SET THIS ALLOCATION_CLASS = 1
```

```
SET THIS_CONTROLLER IDENTIFIER = 99
```

Setting this switch causes the host to load the SYS\$DRIVER, which provides the GG devices. The value range is 1 - 99.

NOTE: D0 (D-zero) can no longer be used as a device LUN in SCSI-3 mode.

- b. To set SCSI-2 mode:

```
SET THIS SCSI = SCSI-2
```

- 18. Change your controller prompts to identify which controller you are working on:

```
SET THIS_CONTROLLER PROMPT="TargetControllerNameTop> "  
SET OTHER_CONTROLLER PROMPT="TargetControllerNameBottom> "  
Example: set this_controller prompt="BuildngBTop> "  
Example: set other_controller prompt="BuildngBBottom> "
```

NOTE: This step takes effect immediately.

- 19. Determine whether mirrored write-back cache is enabled:

```
SHOW THIS_CONTROLLER
```

You should see a display similar to that in Example Display 5.

Example Display 5

```
.  
. .  
.  
Mirrored Cache:  
Not enabled  
.  
. .  
.
```

If mirrored write-back cache is not enabled, issue the following CLI command:

```
SET THIS_CONTROLLER MIRRORED_CACHE
```

The controllers restart after mirrored write-back cache has been set. You should see %LFL and %EVL displays.

NOTE: It may take up to five minutes after restart for diagnostics to complete on the cache. The controller rejects this command until the cache check is complete. If the command is rejected, do not restart the controllers. Wait a few minutes and then try again.

- 20. Confirm that mirrored write-back cache is enabled:

```
SHOW THIS_CONTROLLER
```

If the command is accepted, you should see a display similar to that in Example Display 6.

Example Display 6

.
. .
.

Mirrored Cache:

```
256 megabyte write cache, version 0012
```

```
Cache is GOOD
```

```
No unflushed data in cache
```

.
. .
.

If the command is rejected, do not restart the controllers. Wait a few minutes and then try again.

NOTE: It is not necessary to repeat this step on controller B.

21. Set the fabric topology for each port on both controllers by issuing the following CLI commands:

NOTE: You are prompted to restart the controllers after each command, but you do not need to restart the controllers until all topologies have been set.

```
SET THIS_CONTROLLER PORT_1_TOPOLOGY=FABRIC
```

```
SET THIS_CONTROLLER PORT_2_TOPOLOGY=FABRIC
```

```
SET OTHER_CONTROLLER PORT_1_TOPOLOGY=FABRIC
```

```
SET OTHER_CONTROLLER PORT_2_TOPOLOGY=FABRIC
```

22. Issue the CLI command:

```
SET LOG NOLOG
```

NOTE: You can ignore the error message `ERROR B020:No Logdisk is Configured` if it appears.

23. Restart the controllers by issuing the following CLI commands in the order shown:

```
RESTART OTHER_CONTROLLER
```

```
RESTART THIS_CONTROLLER
```

NOTE: There may be a brief delay before control is returned.

24. After the controllers have restarted, verify that the topology is set correctly:

```
SHOW THIS_CONTROLLER
```

```
SHOW OTHER_CONTROLLER
```

You should see a display similar to that in Example Display 7.

Example Display 7

```

.
.
.
Host PORT_1:
  Reported PORT_ID = nnnn-nnnn-nnnn-nnnn
  . . . . . PORT_1_TOPOLOGY = FABRIC (connection down)
  Address . . . . . =nnnnnn
Host PORT_2:
  Reported PORT_ID = nnnn-nnnn-nnnn-nnnn
  . . . . . PORT_2_TOPOLOGY = FABRIC (connection down)
  Address . . . . . =nnnnnn
  NOREMOTE_COPY
.
.
.

```

25. Enable remote copy functionality:

```
SET THIS_CONTROLLER REMOTE_COPY=TargetControllerName
```

```
Example: set this_controller remote_copy=BuildngB
```

NOTE: Be sure to specify a meaningful target controller name, such as a name that reflects the target node's location. The name can be up to eight characters and must be unique to all of your controllers. Do not use *init*, *initial*, *rem*, or *remote*; they are reserved keywords.

After you have issued this CLI command, you see a series of %LFL and %EVL displays; the controllers automatically restart.

26. Verify that these settings are in place:

```
SHOW THIS_CONTROLLER
```

You should see a display similar to that in Example Display 8.

Example Display 8

```
.  
. .  
Host PORT_2:  
  Reported PORT_ID = nnnn-nnnn-nnnn-nnnn  
  . . . . . PORT_2_TOPOLOGY = FABRIC (up)  
  REMOTE_COPY = BuildngB  
. .  
.
```

Configure Storage at the Target Site

- ⦿ Before you can configure the storage for DRM, you must add disks, create the storagesets, and create units.

Devices and Storagesets

- ⦿ Before you can configure the storage for remote replication, you must add disks, create storagesets, and create units. Follow the instructions in the *Compaq StorageWorks HSG80 ACS Solution Software Version 8.6 Installation and Configuration Guide*, for your operating system, but note the restrictions listed in Table 4-1 on page 4-3 of this document.

NOTE: D0 (D-zero) can no longer be used as a device LUN in SCSI-3 mode.

IMPORTANT: The target site must have exactly the same storageset configuration, unit configuration, and physical layout for remote copy sets as the initiator site. Non-remote copy set (RCS) LUNs may be different at the two sites.

Create Storage Units

- ⦿ 1. Before issuing the following ADD UNIT command, you must already have created the required storagesets.

Issue the following command to create storage units and to disable all access as the units are created.

```
ADD UNIT UnitName StorageSetName DISABLE_ACCESS_PATH=ALL
```

NOTE: If you want to use units that were created with a different ADD command, disable all host access to those units by issuing the following command:

```
SET UnitName DISABLE_ACCESS_PATH=ALL
```

NOTE: For OpenVMS, set device ID on all units with the following command:

```
SET UNIT IDENTIFIER = value
```

Example: set d1 id = 1

This becomes the VMS device ID for DGA1.

Issue this command for each unit. After all units have been created, execute the following procedure.

2. Set the maximum cached transfer size to 128:

```
SET UnitName MAXIMUM_CACHED_TRANSFER_SIZE = 128
```

Repeat this step for each unit.

IMPORTANT: We set the maximum cached transfer size to 128 to maximize throughput of initiator-to-target normalization. If a typical application write I/O is larger than 64 kilobytes, then increase MAXIMUM_CACHED_TRANSFER appropriately. See the *Compaq StorageWorks HSG80 Array Controller Version 8.6 CLI Reference Guide*.

3. Verify that the access on each unit is set to *none*:

```
SHOW UNITS FULL
```

You should see a display similar to that in Example Display 9.

Example Display 9

LUN	Uses	Used by

D1	DISK10000	
LUN ID:	nnnn-nnnn-nnnn-nnnn-nnnn-nnnn-nnnn-nnnn	
NOIDENTIFIER		
Switches:		
RUN	NOWRITE_PROTECT	READ_CACHE
READAHEAD_CACHE	WRITEBACK_CACHE	
MAXIMUM_READ_CACHED_TRANSFER_SIZE	= 128	
MAXIMUM_WRITE_CACHED_TRANSFER_SIZE	= 128	
Access:		
NONE		
State:		
ONLINE	to this controller	

```

NOPREFERRED_PATH
Size: nnnnnnnn blocks
Geometry (C/H/S): ( 7000 / 20 / 254 )

```

```

.
.
.

```

- ④ 4. Distribute the units by setting their preferred path:

```
SET UnitName PREFERRED_PATH=THIS_CONTROLLER
```

or

```
SET UnitName PREFERRED_PATH=OTHER_CONTROLLER
```

Keep the busiest units on different controllers.

- ④ 5. After configuring the units, restart the controllers by issuing the following CLI commands in the order shown. Otherwise, the preferred path settings do not go into effect:

```
RESTART OTHER_CONTROLLER
```

```
RESTART THIS_CONTROLLER
```

- ④ 6. Once the controller has restarted, ensure that your storage settings are in place by issuing the following CLI command:

```
SHOW UNITS FULL
```

You should see a display similar to that in Example Display 10.

Example Display 10

LUN	Uses	Used by

D1	DISK10000	
LUN ID:	nnnn-nnnn-nnnn-nnnn-nnnn-nnnn-nnnn-nnnn	
NOIDENTIFIER		
Switches:		
RUN	NOWRITE_PROTECT	READ_CACHE
READAHEAD_CACHE	WRITEBACK_CACHE	
MAXIMUM_READ_CACHED_TRANSFER_SIZE	= 128	
MAXIMUM_WRITE_CACHED_TRANSFER_SIZE	= 128	
Access:		

```
NONE
State:
ONLINE to this controller
PREFERRED_PATH = OTHER
Size: nnnnnnnn blocks
Geometry (C/H/S): ( 7000 / 20 / 254 )
```

Cable the Target Site

This section provides instructions for cabling the target site.

Connect Fiber Optic Cables Between Controllers and Fibre Channel Switches

Use your established cabling policy to connect the host to the Fibre Channel switches.

- ① 1. Make sure that you have installed all required GBICs into each of the Fibre Channel switches.
- ① 2. Use 50-micron, multi-mode fiber optic cable to connect port 1 of the top controller to the top Fibre Channel switch.
- ① 3. Use 50-micron, multi-mode fiber optic cable to connect port 2 of the top controller to the top Fibre Channel switch.
- ① 4. Use 50-micron, multi-mode fiber optic cable to connect port 1 of the bottom controller to the bottom Fibre Channel switch.
- ① 5. Use 50-micron, multi-mode fiber optic cable to connect port 2 of the bottom controller to the bottom Fibre Channel switch.

NOTE: You should see an illuminated green LED on the switch as soon as the cable is inserted at both ends. This verifies that there is a good connection.

Example:

- a. Insert short wave GBICs in ports 2 and 4 of both the top and bottom Fibre Channel switches.

- b. Connect a multi-mode, 50-micron fiber optic cable from port 1 of the top controller to port 2 of the top Fibre Channel switch (as shown by callout 1 in Figure 4–2).
- c. Connect a second multi-mode, 50-micron fiber optic cable from port 2 of the top controller to port 4 of the top Fibre Channel switch (as shown by callout 2 in Figure 4–2).
- d. Connect a third multi-mode, 50-micron fiber optic cable from port 1 of the bottom controller to port 2 of the bottom Fibre Channel switch (as shown by callout 3 in Figure 4–2).
- e. Connect a fourth multi-mode, 50-micron fiber optic cable from port 2 of the bottom controller to port 4 of the bottom Fibre Channel switch (as shown by callout 4 in Figure 4–2).

Figure 4–2 illustrates the cabling in the example. In this figure, the controllers are on the left and the switches are on the right.

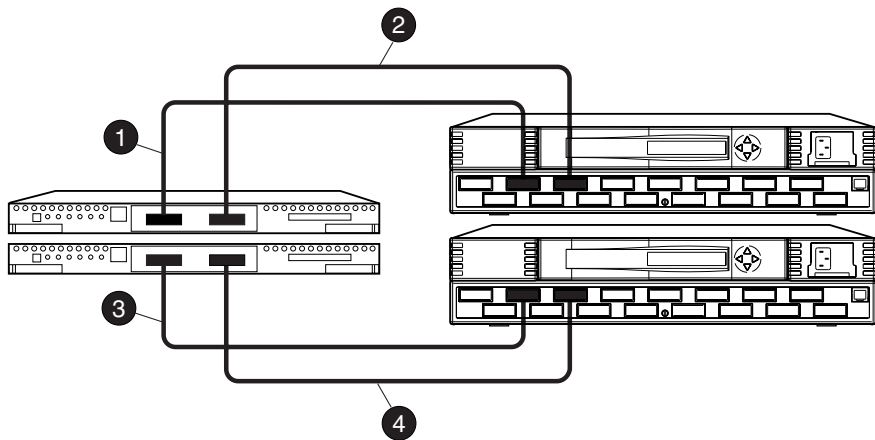

CXO7086A

- ① Cable from port 1 of the top controller to port 2 of the top Fibre Channel switch
- ② Cable from port 2 of the top controller to port 4 of the top Fibre Channel switch
- ③ Cable from port 1 of the bottom controller to port 2 of the bottom Fibre Channel switch
- ④ Cable from port 2 of the bottom controller to port 4 of the bottom Fibre Channel switch

Figure 4–2: Cabling between the controllers and the Fibre Channel switches

Connect the Target Site to the External Fiber Link

- ① Locate the offsite connection points at the target site that link the target site to the initiator site.

Execute the procedure in the next section if you have long wave or very long distance GBICs. Otherwise, go the section “Other Transport Modes” on page 4–21.

Long Wave or Very Long Distance GBICs

- ① 1. Install long wave or very long distance GBIC now if not previously installed.
- ② 2. Connect a single-mode, 9-micron fiber optic cable from the long wave or very long distance GBIC in the top switch to one connection point.
- ③ 3. Connect another single-mode, 9-micron fiber optic cable from the long-wave or very long distance GBIC in the bottom switch to the other connection point.

Other Transport Modes

For a list of the most current software, firmware, patches, drivers, and so on, for each of the supported operating systems in your DRM solution, go to the following website:

<http://www.compaq.com/products/sanworks/drm/index.html>

Follow the Software Support Matrices link, then choose your operating system.

The target site is now physically linked to the initiator site. Figure 4–3 shows what this cabling should look like.

NOTE: You can make sure that switches and ports are connected as you have documented them by issuing the *nbrStateShow* switch command. Issue the *topologyShow* command at the switch to reveal whether you have more than one fiber optic cable between the switches on each site.

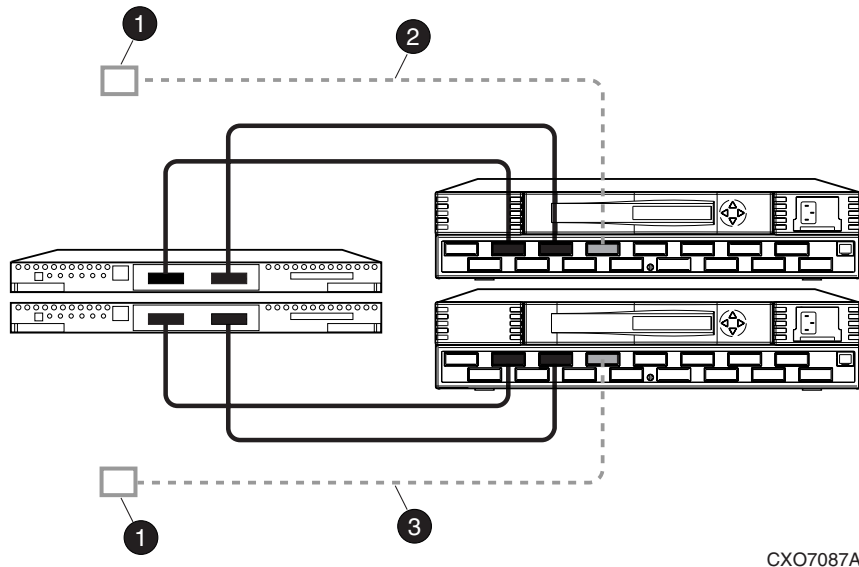

- ❶ Connection points to initiator site
- ❷ Cable from port 6 of the top switch to one connection point
- ❸ Cable from port 6 of the bottom switch to the other connection point

Figure 4-3: Cabling from the target site to the initiator site

Create Switch Zones at the Target Site

You must now create zones on the switches that the controllers are connected to. See Chapter 6, “Configuring the Optional Advanced DRM Solutions,” for more information on creating zones.

- ① 1. Create a zone on the top fabric that contains port 1 of the top controller. This zone will later contain target host connections as well.
- ② 2. Create a zone on the top fabric that contains port 2 of the top controller. This zone will be the top ISL zone.
- ③ 3. Create a zone on the bottom fabric that contains port 1 of the bottom controller. This zone will later contain target host connections as well.

- ④ 4. Create a zone on the bottom fabric that contains port 2 of the bottom controller. This zone will be the bottom ISL zone.

There must be four zones when you are finished (two per fabric).

Configure the Host at the Target Site

This section describes how to set up your host systems at the target site. Follow the procedures for each operating system in your SAN. Execute the appropriate procedure for each of your operating systems:

- “Compaq OpenVMS” on page 4–23
- “Compaq Tru64 UNIX” on page 4–27
- “IBM AIX” on page 4–33
- “Microsoft Windows NT and Windows 2000” on page 4–43
- “Novell NetWare” on page 4–47
- “Sun Solaris” on page 4–51

Compaq OpenVMS

- ④ Before beginning this procedure, make sure that your host is up to date with service packs and patches. For supported revision levels, go to the DRM website:

<http://www.compaq.com/products/sanworks/drm/index.html>

Follow the Software Support Matrices link, then choose your operating system.

Install the Host Bus Adapters

- ④ You must install at least two HBAs in each host system. Record the HBA World Wide ID (WWID) for use later in this section. Refer to the *Compaq StorageWorks 64-Bit PCI-to-Fibre Channel Host Bus Adapter User Guide* for installation instructions.

NOTE: Do not attach your fiber connections to the HBAs until instructed to do so.

Install SWCC (Optional)

- ① You may now install SWCC. For detailed information about SWCC, including installation, refer to the *Compaq StorageWorks Command Console Version 2.4 User Guide*.

Additional Setup

- ① You will need the latest TIMA kit, which is identified at the DRM website:

<http://www.compaq.com/products/sanworks/drm/index.html>

Follow the Software Support Matrices link, then choose your operating system.

Connect the Host to the SAN

Use your established cabling policy to connect the host to the Fibre Channel switch.

- ① 1. Use 50-micron, multi-mode fiber optic cable to connect one adapter of each pair to the top Fibre Channel switch.
- ① 2. Use 50-micron, multi-mode fiber optic cable to connect the other adapter of each pair to the bottom Fibre Channel switch.

For example, if there are four adapters in a server, the first and third adapters must be connected to the top Fibre Channel switch and the second and fourth adapters must be connected to the bottom Fibre Channel switch.

- ① 3. Verify that the connection between the host and the switch has been made:

SHOW CONNECTIONS

You should see a display similar to that in Example Display 11.

Example Display 11

```

Connection Unit
Name      Operating system  Controller  Port  Address  Status  Offset
!NEWCON00  WINNT             THIS        1     210013  online  0
  HOST_ID=nnnn-nnnn-nnnn-nnnn . . . . ADAPTER_ID=nnnn-nnnn-nnnn-nnnn
!NEWCON01  WINNT             OTHER        1     200013  online  0
  HOST_ID=nnnn-nnnn-nnnn-nnnn . . . . ADAPTER_ID=nnnn-nnnn-nnnn-nnnn
    
```

Rename the Host Connections

To better identify which hosts you are working with, Compaq recommends that you rename the host connections, using a meaningful connection name for each. Each HBA appears as a connection. An HBA can be identified by its WWN, which you recorded when you installed the HBAs, and which appears in the connection description.

Initially, each connection is named !NEWCONxx. It is much easier to track connections if the connection names are meaningful, like "HostB1."

IMPORTANT: If you use scripting to automate failover and failback operations, do not use dashes (hyphens) as separators in your naming convention—use underscores instead. Dashes are not allowed by the Perl scripting language.

1. We suggest that you use the worksheet in Figure 4–4 when renaming your hosts.

!NEWCON xx	World Wide Name	Host Name	Host OS Type	HBA Number

NOTE: Note: If you use scripting to automate failover and failback operations, do not use dashes (hyphens) as separators in your naming convention—use underscores instead. Dashes are not allowed by the Perl scripting language.

Figure 4–4: Host renaming worksheet

- 2. When you have completed the worksheet, rename the connections:

```
RENAME !NEWCONxx TargetHostConnectionNamex
```

```
RENAME !NEWCONxx TargetHostConnectionNamey
```

```
Example: rename !NEWCONxx HostB1
```

```
Example: rename !NEWCONxx HostB2
```

- 3. Set the operating system for each connection to OpenVMS:

```
SET TargetHostConnectionNamex OPERATING_SYSTEM = VMS
```

```
Example: set HostB1 operating_system = vms
```

```
Example: set HostB2 operating_system = vms
```

- 4. When you have finished renaming your host connections, issue the following command to see your settings:

```
SHOW CONNECTIONS
```

You should see a display similar to that in Example Display 12.

Example Display 12

Connection Unit

Name	Operating system	Controller	Port	Address	Status	Offset
HostB1	VMS	THIS	1	210013	online	0
		HOST_ID=nnnn-nnnn-nnnn-nnnn		ADAPTER_ID=nnnn-nnnn-nnnn-nnnn		
HostB2	VMS	OTHER	1	200013	online	0
		HOST_ID=nnnn-nnnn-nnnn-nnnn		ADAPTER_ID=nnnn-nnnn-nnnn-nnnn		

Update Switch Zones

The switch zones created earlier must be updated with the host connection information (refer to Chapter 6, “Configuring the Optional Advanced DRM Solutions,” for detailed information on zone creation):

- 1. On the top fabric, add the host connection to the zone that contains port 1 of the top target controller.
- 2. On the bottom fabric, add the host connection to the zone that contains port 1 of the bottom target controller.

Your OpenVMS host is now configured to use DRM. Execute this procedure for each OpenVMS host present at the target site. After configuring the target site hosts, go to the section “Configure the Controllers at the Initiator Site” on page 4–56.

Compaq Tru64 UNIX

- ⦿ Before starting this procedure, make sure that your host is up to date with service packs and patches. For supported revision levels, go to the DRM website:

<http://www.compaq.com/products/sanworks/drm/index.html>

Follow the Software Support Matrices link, then choose your operating system.

Install the Host Bus Adapters

- ⦿ You must install at least two HBAs in each host system. Record the HBA WWID for use later in this chapter. Refer to the *Compaq StorageWorks 64-Bit PCI-to-Fibre Channel Host Bus Adapter User Guide* for installation instructions.

NOTE: Do not attach your fiber connections to the HBAs at this time. The driver is installed in the following step.

Install the Host Bus Adapter Driver

- ⦿ The EMX driver for Tru64 UNIX is already installed. Verify that the driver version and firmware version are at a supported level:

```
cat /usr/adm/messages |grep KGPSA
```

You should see a display similar to that in Example Display 13.

Example Display 13

```
Apr 19 14:19:37 tru002 vmunix: KGPSA-CA : Driver Rev 1.30:  
F/W Rev 3.81A4(2.01A0): wwn 1000-0000-c924-fe8c
```

Multipath Software

Tru64 UNIX has native multipath support with path auto-detection. No further configuration is required.

Install SWCC (Optional)

- ⦿ You may now install SWCC. For detailed information about SWCC, including installation, refer to the *Compaq StorageWorks Command Console Version 2.4 User Guide*.

Connect the Host to the SAN

Use your established cabling policy to connect the host to the Fibre Channel switch.

- ① 1. Use 50-micron, multi-mode fiber optic cable to connect one adapter of each pair to the top Fibre Channel switch.
- ② 2. Use 50-micron, multi-mode fiber optic cable to connect the other adapter of each pair to the bottom Fibre Channel switch.

For example, if there are four adapters in a server, the first and third adapters must be connected to the top Fibre Channel switch and the second and fourth adapters must be connected to the bottom Fibre Channel switch.

- ③ 3. Verify that the connection between the host and the switch has been made:

```
SHOW CONNECTIONS
```

You should see a display similar to that in Example Display 14.

Example Display 14

```
Connection Unit
Name           Operating system  Controller  Port   Address   Status Offset
!NEWCON00     WINNT             THIS        1      210013    online 0
HOST_ID=nnnn-nnnn-nnnn-nnnn . . . . ADAPTER_ID=nnnn-nnnn-nnnn-nnnn
!NEWCON01     WINNT             OTHER        1      200013    online 0
HOST_ID=nnnn-nnnn-nnnn-nnnn . . . . ADAPTER_ID=nnnn-nnnn-nnnn-nnnn
```

Rename the Host Connections

To better identify which hosts you are working with, Compaq recommends that you rename the host connections, using a meaningful connection name for each. Each HBA appears as a connection. An HBA can be identified by its WWN, which you recorded when you installed the HBAs, and which appears in the connection description.

Initially, each connection is named !NEWCONxx. It is much easier to track connections if the connection names are meaningful, like “HostB1.”

IMPORTANT: If you use scripting to automate failover and failback operations, do not use dashes (hyphens) as separators in your naming convention—use underscores instead. Dashes are not allowed by the Perl scripting language.

- 1. We suggest that you use the worksheet in Figure 4–4 on page 4–25 when renaming your hosts.

- 2. When you have completed the worksheet, rename the connections:

```
RENAME !NEWCONxx TargetHostConnectionNamex
```

```
RENAME !NEWCONxx TargetHostConnectionNamey
```

```
Example: rename !NEWCONxx HostB1
```

```
Example: rename !NEWCONxx HostB2
```

- 3. Set the operating system for each connection to Tru64 UNIX:

```
SET TargetHostConnectionNamex OPERATING_SYSTEM = TRU64_UNIX
```

```
Example: set HostB1 operating_system = tru64_unix
```

- 4. When you have finished renaming your host connections, issue the following command to see your settings:

```
SHOW CONNECTIONS
```

You should see a display similar to that in Example Display 15.

Example Display 15

Connection Unit

Name	Operating system	Controller	Port	Address	Status	Offset
HostB1	Tru64_UNIX THIS	1	210013	online	0	
	HOST_ID=nnnn-nnnn-nnnn-nnnn		ADAPTER_ID=nnnn-nnnn-nnnn-nnnn			
HostB2	Tru64_UNIX OTHER	1	200013	online	0	
	HOST_ID=nnnn-nnnn-nnnn-nnnn		ADAPTER_ID=nnnn-nnnn-nnnn-nnnn			

Update Switch Zones

The switch zones created earlier must be updated with the host connection information (refer to Chapter 6, “Configuring the Optional Advanced DRM Solutions,” for detailed information on zone creation):

- 1. On the top fabric, add the host connection to the zone that contains port 1 of the top target controller.
- 2. On the bottom fabric, add the host connection to the zone that contains port 1 of the bottom target controller.

Your Tru64 UNIX host is now configured to use DRM. Execute this procedure for each Tru64 UNIX host present at the target site. After configuring the target site hosts, go to the section “Configure the Controllers at the Initiator Site” on page 4–56.

HP-UX

- ⦿ Before starting this procedure, make sure that your host is up to date with service packs and patches. For supported revision levels, go to the DRM website:

<http://www.compaq.com/products/sanworks/drm/index.html>

Follow the Software Support Matrices link, then choose your operating system.

Existing Fibre Channel HP-UX Configurations

- ⦿ Refer to *Compaq SANworks Secure Path V3.0 for HP-UX Installation and Reference Guide* for information on:
 - Changing from SCSI-2 to SCSI-3, Command Console LUN (CCL) behavior
 - Changing HBAs and switch modes from QuickLoop to Fabric

Install the Host Bus Adapters

You must install at least two HBAs in each host system. HBAs must be installed in pairs.

- ⦿ Power down your HP-UX host and install the HBAs in any of the free PCI slots. Install the HBA device driver if needed.

Refer to vendor's adapter service and user guide for installation instructions.

Connect the Host to the SAN

Use your established cabling policy to connect the host to the Fibre Channel switches:

- ⦿ 1. Use 50-micron, multi-mode fiber optic cable to connect one adapter of each pair to the top fabric.
- ⦿ 2. Use 50-micron, multi-mode fiber optic cable to connect the other adapter of each pair to the bottom fabric.

For example, if there are four adapters in a server, the first and third adapters must be connected to the top Fibre Channel switch and the second and fourth adapters must be connected to the bottom Fibre Channel switch.

Rename the Host Connections

To better identify which hosts you are working with, Compaq recommends that you rename the host connections, using a meaningful connection name for each. Each HBA appears as a connection on the HSG80. An HBA can be identified by its WWN in the connection description. To find the WWN of each HBA, refer to Chapter 7, “Troubleshooting.”

Initially, each connection on the HSG80 is named !NEWCONxx. It is much easier to track connections if the connection names are meaningful, like "HostB1."

IMPORTANT: If you use scripting to automate failover and failback operations, do not use dashes (hyphens) as separators in your naming convention-use underscores instead. Dashes are not allowed by the Perl scripting language.

- ① 1. We suggest that you use the worksheet in Figure 4–4 on page 4–25 when renaming your hosts. You may reproduce this worksheet as needed.
- ① 2. When you have completed the worksheet, rename the connections:

```
RENAME !NEWCONxx TargetHostConnectionNamex
RENAME !NEWCONxx TargetHostConnectionNamey
Example: rename !NEWCONxx HostB1
Example: rename !NEWCONxx HostB2
```
- ① 3. Change the operating system for each connection to HP-UX:

```
SET !NEWCONxx operating_system=hp
```
- ① 4. After you have renamed the host connections, issue the following command to see the new settings:

```
SHOW CONNECTIONS
```

Update Switch Zones

The switch zones created earlier must be updated with the host connection information:

- ① 1. On the top fabric, add the host connection to the zone that contains port 1 of the top target controller.
- ① 2. On the bottom fabric, add the host connection to the zone that contains port 1 of the bottom target controller.

Disable Access to the Hosts at the Target Site

- Ⓞ To prevent the target hosts from writing to any remote copy set targets, access must be disabled:

```
SET UnitName DISABLE=ALL
```

Repeat for each unit.

NOTE: This step is for remote copy set LUNs only.

Install the Secure Path Fibre Channel Host Bus Adapter Device Driver

- Ⓞ Install the Secure Path Fibre Channel HBA device driver according to the instructions in the *Compaq SANworks Secure Path V3.0 for HP-UX Installation and Reference Guide*.

Verify the Disks

- Ⓞ Verify that the non-remote copy set disks are present by issuing the following command:

```
ioscan -fnCdisk
```

The output should be similar to that shown in Example Display 16.

Example Display 16

Class	I	H/W Path	Driver	S/W State	H/W Type	Description
disk	0	0/0/1/1.2.0	sdisk	CLAIMED	DEVICE	SEAGATE ST39204LC
			/dev/dsk/c1t2d0		/dev/rdisk/c1t2d0	
disk	1	0/0/255.0.0.0	sdisk	CLAIMED	DEVICE	HSG80 LUN
		0x60001FE100080D100009834019820144				
			/dev/dsk/c12t0d0		/dev/rdisk/c12t0d0	

NOTE: If the device special files (/dev/dsk/c12t0d0 /dev/rdisk/c12t0d0, for example) are not displayed, then issue the `insf -e` command to install special files, then repeat the `ioscan -fnCdisk` command.

Configure the SWCC Agent (Optional)

- Ⓞ The SWCC Agent may now be installed and configured. Refer to the *Compaq StorageWorks HSG80 ACS Solution Software Version 8.6 for HP-UX Installation and Configuration Guide*, Chapter 4, for installation instructions.

Additional Setup

- ① You may now configure volume groups, logical volumes, and file systems on any non-remote copy set LUNs on the storage arrays using normal HP-UX procedures.
Your HP-UX host is now configured to use DRM. Repeat this procedure for each HP-UX host present at your target site. After configuring the target site hosts, go to the section “Configure the Controllers at the Initiator Site” on page 4–56.

IBM AIX

- ① Before starting this procedure, make sure that your host is up to date with service packs and patches. For supported revision levels, go to the DRM website:

<http://www.compaq.com/products/sanworks/drm/index.html>

Follow the Software Support Matrices link, then choose your operating system.

Install the Host Bus Adapters

You must install at least two HBAs in each host system. HBAs must be installed in pairs. You may install a maximum of six adapters per host, but two adapter pairs must not share the same unit on the RAID system.

- ① Power down your AIX host and install the HBAs in any of the free PCI slots. The HBAs work in either a 32-bit or 64-bit PCI card slot.

NOTE: Do not attach your fiber connections to the HBAs at this time and do not install the AIX driver that comes with the Cambex HBA. The driver is installed in the following step.

Install the Secure Path Fibre Channel Host Bus Adapter Device Driver and the AIX Platform Kit

- ① The following describes the preferred method for installing the *StorageWorks* platform kit software for IBM AIX and Secure Path Secure Path Fibre Channel HBA device driver software on your AIX servers. Use these instructions, in the given order, instead of the installation instructions in the platform kit (*Compaq StorageWorks HSG80 ACS Version 8.6 Solution Software for IBM AIX Installation and Configuration Guide*) and Secure Path software (*Compaq SANworks Secure Path V2.0 for IBM AIX Installation and Reference Guide*).

New Installation

Follow these instructions if you are performing a new installation of the *StorageWorks* platform kit for AIX and Secure Path.

New Installation Assumptions

- All components are not connected.
- AIX operating system version is V4.3.3.
- Cambex is the Fibre Channel adapter.
- Secure Path is V2.0A.
- Solution platform kit is V8.6.
- HSG80 ACS code is V8.6-4P.
- Storage subsystem is pre-configured with or without a CCL LUN.
- Mode is SCSI-2 or SCSI-3, with the LUN connection type set as WINNT.
- Host bus adapters (HBAs) are installed in pairs.
- No volume groups, logical volumes, or file systems are created.
- Clustering services is not installed.

HBA Limitations

HBAs have the following limitations:

- Addressing of LUNS is limited to 16 devices. This limitation must be considered when planning the sub-system storage configuration.
- Configuring a CCL LUN will leave 15 LUN addresses.

Installation Steps

- ① 1. Install Fibre Channel HBAs. Do not connect fiber cables at this time.
NOTE: The maximum number of HBAs per host is 6. Refer to IBM's PCI Adapter Placement Reference document.
- ② 2. Power up or boot server.
- ③ 3. Load *StorageWorks* platform kit for AIX v8.6:
 - a. Load platform CD into CD drive.

- b. Enter the following commands:

```
#mkdir /cdrom
#mount -v cdrfs -r /dev/cd0 /cdrom
#cd /cdrom
#./INSTALL (follow the prompts)
```

The system will not find any DEC HSG80 RAID array devices at this time.

The option of installing the SWCC Agent will be presented at this time.

Choose **Yes**. Installation of the SWCC Agent will begin. When installation is complete, you will be asked if you wish to start the Agent:

- Answer **Yes** if the host will be used as an SWCC Agent.
- Answer **No** if the host will not be used as an SWCC Agent.

Refer to the *Compaq StorageWorks HSG80 ACS Solution Software Version 8.6 for IBM AIX Installation and Configuration Guide* for additional information on this process.

```
#umount /cdrom
```

- ④ 4. Remove platform kit Fibre Channel driver v1.5.11.1 with the following commands:

```
#installp -u PC1000.driver.obj
#lslpp -l PC1000.driver.obj
```

- ④ 5. Load Secure Path for IBM V2.0A, Fibre Channel driver v1.5.15.1:

- a. Load Secure Path CD into CD drive.

- b. Enter the following commands:

```
#mkdir /mnt
#mount -v cdrfs -r /dev/cd0 /mnt
#mkdir /tmp/driver
#cp /mnt/driver/PC1000SP.image /tmp/driver
#cd /tmp/driver
#installp -acd PC1000SP.image all
#lslpp -l PC1000.driver.obj
#umount /mnt
```

6. Run Configuration Manager to add Fibre Channel HBA to the configuration database. Enter the following commands:

```
#cfgmgr -v
#lsdev -Cc adapter
```

7. Connect fiber cables to HBAs.

8. Run Configuration Manager to add hdisks / HSG80 Raid Array to the configuration database. Enter the following commands:

```
#cfgmgr -v
#lsdev -Cc disk
```

The system will find HSG80 Raid Array devices at this time. If CCL is enabled on the HSG80 the server will find a Command Console LUN.

Multiple instances of the Command Console LUN hdisks may be displayed. Remove all of the higher numbered hdisks, keeping only the lowest numbered hdisk of the Command Console LUN. Remove the hdisks with the following command:

```
#rmdev -dl hdiskx
```

where x is the number of the hdisk to be removed.

9. Run the *StorageWorks* Install Agent, if required:

```
#cd /usr/stgwks2
# ./stgwks_aix.sh
```

Choose **Option 1**.

10. Create Volume Groups, Logical Volumes, and Files Systems.
11. Configure clustering services (if required).
12. Check the status of the host bus adapters periodically.

Upgrade Installation

If you are currently using an AIX server in transparent failover mode, and you wish to upgrade to ACS Version 8.6-4P in a DRM environment, follow these instructions.

Upgrade Installation Assumptions

- All components are connected.
- AIX OS is upgraded to V4.3.3.
- Cambex Fibre Channel adapters are installed.
- A version of Secure Path is loaded.
- A version of the Solution platform kit is loaded, or has been upgraded.
- HSG80 ACS code is being upgraded to V8.6-4P.
- Storage subsystem is pre-configured with or without a CCL LUN, in SCSI-2 or SCSI-3 mode, with the LUN connection type set as WINNT.
- HBAs are installed in pairs.
- Volume groups, logical volumes, and file systems created.
- Clustering services may be installed.

HBA Limitations

HBAs have the following limitations:

- Addressing of LUNS is limited to 16 devices. This limitation must be considered when planning the sub-system storage configuration.
- Configuring a CCL LUN will leave 15 LUN addresses.

Installation Steps

- ① 1. Stop all I/O.
- ① 2. Stop clustering services (if running).
- ① 3. Stop the *StorageWorks* Agent (if running).
- ① 4. Backup all Volume Groups (highly recommended).

5. Unmount and perform file system check on all logical volumes, varyoff, and export volume groups, with the following commands:

```
#umount /dev/(logical_volume_name)
#fsck /(file_system_name)
#varyoffvg (volume_group_name)
```
6. Remove all hdisks associated with DEC HSG80 RAID array from the configuration database with the following commands:

```
#lsdev -Cc disk
#rmdev -dl hdiskx (x is the hdisk number)
```
7. Remove all Fibre Channel adapters from the configuration database with the following commands:

```
#lsdev -Cc adapter
#rmdev -dl scsix (x is the Cambex adapter number)
```
8. Uninstall the Fibre Channel driver with the following command:

```
#installp -u PC1000.driver.obj
```
9. Disconnect all Fibre Channel adapter cables.
10. If adding an additional Cambex Fibre Channel adapter, shutdown the server with the following command:

```
#shutdown
```
11. Install additional Fibre Channel Host Bus Adapters (if required). Do not connect fiber cables at this time.

NOTE: The maximum number of HBAs per host is 6. Refer to IBM's PCI Adapter Placement Reference document.
12. Power up or boot server.
13. Load *StorageWorks* platform kit for AIX v8.6:
 - a. Load platform CD into CD drive.
 - b. Enter the following commands:

```
#mkdir /cdrom
#mount -v cdrfs -r /dev/cd0 /cdrom
```

```
#cd /cdrom
#./INSTALL (follow the prompts)
```

The system will not find any DEC HSG80 RAID array devices at this time.

The option of installing the SWCC Agent will be presented at this time. Choose **Yes**. Installation of the SWCC Agent will begin. When installation is complete, you will be asked if you wish to start the Agent:

- Answer **Yes** if the host will be used as an SWCC Agent.
- Answer **No** if the host will not be used as an SWCC Agent.

Refer to the *Compaq StorageWorks HSG80 ACS Solution Software Version 8.6 for IBM AIX Installation and Configuration Guide* for additional information on this process.

```
#umount /cdrom
```

- ④ 14. Remove platform kit Fibre Channel driver v1.5.11.1 with the following commands:

```
#installp -u PC1000.driver.obj
#lslpp -l PC1000.driver.obj
```

- ④ 15. Load Secure Path for IBM V2.0A, Fibre Channel driver v1.5.15.1:
- a. Load Secure Path CD in to CD drive.
 - b. Enter the following commands:

```
#mkdir /mnt
#mount -v cdrfs -r /dev/cd0 /mnt
#mkdir /tmp/driver
#cp /mnt/driver/PC1000SP.image /tmp/driver
#cd /tmp/driver
#installp -acd PC1000SP.image all
#lslpp -l PC1000.driver.obj
#umount /mnt
```

- ④ 16. Run Configuration Manger to add Fibre Channel HBA to the configuration database with the following commands:

```
#cfgmgr -v
#lsdev -Cc adapter
```

- ① 17. Connect fiber cables to HBAs.
- ① 18. Run Configuration Manager to add hdisks or HSG80 Raid Array to the configuration database with the following commands:

```
#cfgmgr -v  
#lsdev -Cc disk
```

The system will find HSG80 Raid Array devices at this time. If CCL is enabled on the HSG80 the server will find a Command Console LUN.

Multiple instances of the Command Console LUN hdisks may be displayed. Remove all of the higher numbered hdisks, keeping only the lowest numbered hdisk of the Command Console LUN. Remove the hdisks with the following command:

```
#rmdev -dl hdiskx
```

where *x* is the number of the hdisk to be removed.

- ① 19. Run the *StorageWorks* Install Agent, if required:

```
#cd /usr/stgwks2  
# ./stgwks_aix.sh
```

Choose **Option 1**.

- ① 20. Reestablish volume groups, logical volumes, and files systems with the following commands:

```
#varyonvg (volume_group_name)  
#mount /dev/(logical_volume__name)
```

- ① 21. Reestablish clustering services (if required).
- ① 22. Check the status of the host bus adapters periodically.

Connect the Host to the SAN

Use your established cabling policy to connect the host to the Fibre Channel switches:

- ① 1. Use 50-micron, multi-mode fiber optic cable to connect one adapter of each pair to the top fabric.
- ① 2. Use 50-micron, multi-mode fiber optic cable to connect the other adapter of each pair to the bottom fabric.

Example: If there are four adapters in a server, the first and third should be connected to the top fabric; and the second and fourth adapters should be connected to the bottom fabric.

Rename the Host Connections

To better identify which hosts you are working with, Compaq recommends that you rename the host connections, using a meaningful connection name for each. Each HBA appears as a connection. An HBA can be identified by its WWN, which you recorded when you installed the HBAs, and which appears in the connection description.

Initially, each connection is named !NEWCONxx. It is much easier to track connections if the connection names are meaningful, like “HostB1.”

IMPORTANT: If you use scripting to automate failover and failback operations, do not use dashes (hyphens) as separators in your naming convention—use underscores instead. Dashes are not allowed by the Perl scripting language.

1. We suggest that you use the worksheet in Figure 4–4 on page 4–25 when renaming your hosts. You may reproduce this worksheet as needed.

2. When you have completed the worksheet, rename the connections:

```
RENAME !NEWCONxx TargetHostConnectionNamex
```

```
RENAME !NEWCONxx TargetHostConnectionNamey
```

```
Example: rename !NEWCONxx HostB1
```

```
Example: rename !NEWCONxx HostB2
```

3. Change the operating system for each connection to AIX (use WINNT for this function):

```
SET !NEWCONxx OPERATING_SYSTEM=WINNT
```

4. After you have renamed the host connections, issue the following command to see the new settings:

```
SHOW CONNECTIONS
```

Update Switch Zones

The switch zones created earlier must be updated with the host connection information:

1. On the top fabric, add the host connection to the zone that contains port 1 of the top target controller.
2. On the bottom fabric, add the host connection to the zone that contains port 1 of the bottom target controller.

Disable Access to the Hosts at the Target Site

1. To prevent the target hosts from writing to any remote copy set targets, access must be disabled:

```
SET UnitName DISABLE=ALL
```

Repeat for each unit.

NOTE: This step is for remote copy set LUNs only.

Verify the Disks

1. Verify that disks are present by issuing the following commands:

```
cfgmgr -v  
lsdev -Cc disk
```

The `cfgmgr` command configures `hdisk`s for all LUNs your system can access on the storage arrays.

The output of the `lsdev` command should be similar to that shown in Example Display 17.

Example Display 17

```
hdisk0 Available 10-60-00-6,0 16 Bit LVD SCSI Disk Drive  
hdisk1 Available 20-58-00-8,0 DEC HSG80 Command Console LUN  
hdisk2 Available 20-58-00-8,7 DEC HSG80 RAID Array
```

In this example:

- `hdisk0` represents the internal hard drive of your AIX host
- `hdisk1` represents the Command Console LUN (CCL)

- hdisk2 represents a single unit or LUN (LUN 7 as denoted by the last number in the line 20-58-00-8,7).

NOTE: In the example, hdisk2 represents a non-remote copy set because you have disabled access to all RCS LUNs.

Configure the SWCC Agent (Optional)

- ⦿ The SWCC Agent may now be installed and configured. Refer to the *Compaq StorageWorks HSG80 ACS Solution Software Version 8.6 for IBM AIX Installation and Configuration Guide* for installation instructions.

Additional Setup

- ⦿ You may now configure volume groups, logical volumes, and file systems on any non-remote copy set LUNs on the storage arrays using normal AIX procedures.

Your AIX host is now configured to use DRM. Repeat this procedure for each AIX host present at your target site. After configuring the target site hosts, go to the section “Configure the Controllers at the Initiator Site” on page 4–56.

Microsoft Windows NT and Windows 2000

- ⦿ Before beginning this procedure, make sure that your host is up to date with service packs and patches. For supported revision levels, go to the DRM website:

<http://www.compaq.com/products/sanworks/drm/index.html>

Follow the Software Support Matrices link, then choose your operating system.

Ensure that the hosts are not connected to the Fibre Channel switches during this procedure.

Install the Host Bus Adapters and Update Firmware

- ⦿ You must install at least two HBAs in each host system. HBAs must be installed in pairs. Refer to the *Compaq StorageWorks 64-Bit PCI-to-Fibre Channel Host Bus Adapter User Guide* for installation instructions. For updated firmware version, go to the DRM website:

<http://www.compaq.com/products/sanworks/drm/index.html>

Follow the Software Support Matrices link, then choose your operating system.

NOTE: Do not attach your fiber connections to the HBAs at this time. The driver is installed in the following step.

Install the Host Bus Adapter Driver

- ① Use the Device Manager to install the HBA driver. For updated driver version information, go to the DRM website:

<http://www.compaq.com/products/sanworks/drm/index.html>

Follow the Software Support Matrices link, then choose your operating system.

Install Fibre Channel Software

- ① Install the Compaq Fibre Channel software on the host. For updated Fibre Channel software version information, go to the DRM website:

<http://www.compaq.com/products/sanworks/drm/index.html>

Follow the Software Support Matrices link, then choose your operating system.

Install Multipath Software

Install Secure Path for Windows. For installation instructions, refer to the *Compaq SANworks Secure Path Version 3.1 for Microsoft Windows Installation and Reference Guide*.

- ① 1. Verify that the Secure Path Agent is installed by going to Administrative Tools and selecting Services. The Secure Path Agent must be set for automatic setup and started.
- ① 2. Use the Secure Path Agent Configuration utility to grant access to the client at both the initiator and target sites. To do this, follow these menus:
Start > Programs > Secure Path > Secure Path Cfg.
- ① 3. You can set the password and allow client access via the Secure Path Agent Configuration utility.
NOTE: Compaq recommends that you set both the fully qualified and unqualified domain name server (DNS) names as valid, authorized clients.
- ① 4. Restart the Secure Path Agent service for changes to take effect.

Install SWCC (Optional)

- ① You may now install SWCC. For detailed information about SWCC, including installation, refer to the *Compaq StorageWorks Command Console Version 2.4 User Guide*.

Connect the Host to the SAN

Use your established cabling policy to connect the host to the Fibre Channel switches.

- ① 1. Use 50-micron, multi-mode fiber optic cable to connect one adapter of each HBA pair to the top Fibre Channel switch.
- ② 2. Use 50-micron, multi-mode fiber optic cable to connect the other adapter of each pair to the bottom Fibre Channel switch.

For example, if there are four adapters in a server, the first and third adapters must be connected to the top Fibre Channel switch and the second and fourth adapters must be connected to the bottom Fibre Channel switch.

- ③ 3. Verify that the connection between the host and the switches has been made:

`SHOW CONNECTIONS`

You should see a display similar to that in Example Display 18.

Example Display 18

```

Connection Unit
Name      Operating system  Controller  Port   Address  Status Offset
!NEWCON00  WINNT              THIS        1      210013   online  0
           HOST_ID=nnnn-nnnn-nnnn-nnnn . . . . ADAPTER_ID=nnnn-nnnn-nnnn-nnnn
!NEWCON01  WINNT              OTHER       1      200013   online  0
           HOST_ID=nnnn-nnnn-nnnn-nnnn . . . . ADAPTER_ID=nnnn-nnnn-nnnn-nnnn
    
```

Rename the Host Connections

To better identify which hosts you are working with, Compaq recommends that you rename the host connections, using a meaningful connection name for each. Each HBA appears as a connection. An HBA can be identified by its WWN, which you recorded when you installed the HBAs, and which appears in the connection description.

Initially, each connection is named !NEWCONxx. It is much easier to track connections if the connection names are meaningful, like “HostB1.”

IMPORTANT: If you use scripting to automate failover and failback operations, do not use dashes (hyphens) as separators in your naming convention—use underscores instead. Dashes are not allowed by the Perl scripting language.

1. We suggest that you use the worksheet in Figure 4–4 on page 4–25 when renaming your hosts.
2. When you have completed the worksheet, rename the connections:

```
RENAME !NEWCONxx TargetHostConnectionNameX
```

```
RENAME !NEWCONxx TargetHostConnectionNameY
```

```
Example: rename !NEWCONxx HostB1
```

```
Example: rename !NEWCONxx HostB2
```

3. Set the operating system for each connection to Windows (NT is the setting for both Windows NT and Windows 2000):

```
SET TargetHostConnectionNameX OPERATING_SYSTEM = WINNT
```

```
Example: set HostB1 operating_system = winnt
```

```
Example: set HostB2 operating_system = winnt
```

4. When you have finished renaming your host connections, confirm your new settings:

```
SHOW CONNECTIONS
```

You should see a display similar to that in Example Display 19.

Example Display 19

Connection Unit

Name	Operating system	Controller	Port	Address	Status	Offset
HostB1	WINNT	THIS	1	210013	online	0
		HOST_ID=nnnn-nnnn-nnnn-nnnn . . .	ADAPTER_ID=nnnn-nnnn-nnnn-nnnn			
HostB2	WINNT	OTHER	1	200013	online	0

HOST_ID=nnnn-nnnn-nnnn-nnnn ADAPTER_ID=nnnn-nnnn-nnnn-nnnn

Update Switch Zones

The switch zones created earlier must be updated with the host connection information (refer to Chapter 6, “Configuring the Optional Advanced DRM Solutions,” for detailed information on zone creation):

1. On the top fabric, add the host connection to the zone that contains port 1 of the top target controller.
2. On the bottom fabric, add the host connection to the zone that contains port 1 of the bottom target controller.

Your Windows host is now configured to use DRM. Execute this procedure for each Windows host present at the target site. After configuring the target site hosts, go to the section “Configure the Controllers at the Initiator Site” on page 4–56.

Novell NetWare

1. Before beginning this procedure, make sure that your host is up to date with support packs and patches. For supported revision levels, go to the DRM website:

<http://www.compaq.com/products/sanworks/drm/index.html>

Follow the Software Support Matrices link, then choose your operating system.

Install the Host Bus Adapters

1. You must install at least two HBAs in each host system. Record the HBA WWID for use later in this section. Refer to the *Compaq StorageWorks 64-Bit PCI-to-Fibre Channel Host Bus Adapter User Guide* for installation instructions.

NOTE: Do not attach your fiber connections to the HBAs until instructed to do so. The driver is installed in the following step.

Install the Host Bus Adapter Driver

1. The NetWare HBA multi-path driver is CPQFC.HAM. The driver is installed as part of the Secure Path Agent installation.

Install Secure Path Agent

For installation instructions, refer to the *Compaq SANworks Secure Path Version 3.0 for Novell NetWare Installation and Reference Guide*. After installation, execute the following procedure:

1. Verify that the Secure Path Agent is installed by typing the following at the server console:

```
modules cpqspagt
```

If the agent has installed properly, you will see a display of version information.

Ensure that the Secure Path Agent is set for automatic startup. Normally, the Secure Path installation program sets automatic startup by loading *cpqspagt.nlm* in the *autoexec.ncf* file.

2. Use the Secure Path Agent Configuration screen at the server to grant access to the client at both the initiator and target sites. To do this:
 - a. From the NetWare server, toggle to the Secure Path NLM (NetWare Loadable Module) screen.
 - b. At the Main menu, select 2) *Client Administration*, then select 2) *Add a Client*.
 - c. Type the fully qualified DNS name for the client, then press **Enter**.
 - d. Press **Escape** to return to the Main menu.
3. To set the password and allow client access via the Secure Path Agent Configuration, execute the following procedure:
 - a. At the Main menu, select 1) *Agent Administration*, then select 1) *Change Password*.
 - b. Type a password for client access and then retype the password for verification.
 - c. Press **Escape** to return to the Main menu.

NOTE: Compaq recommends that you set both the fully qualified and unqualified DNS names as valid, authorized clients.

Install Secure Path Manager

- For installation instructions, refer to the *Compaq SANworks Secure Path Version 3.0 for Novell NetWare Installation and Reference Guide*.

Install SWCC (Optional)

- ① You may now install SWCC. For detailed information about SWCC, including installation, refer to the *Compaq StorageWorks Command Console Version 2.4 User Guide*.

Connect the Host to the SAN

Use your established cabling policy to connect the host to the Fibre Channel switch.

- ① 1. Use 50-micron, multi-mode fiber optic cable to connect one adapter of each pair to the top Fibre Channel switch.
- ② 2. Use 50-micron, multi-mode fiber optic cable to connect the other adapter of each pair to the bottom Fibre Channel switch.

For example, if there are four adapters in a server, the first and third adapters must be connected to the top Fibre Channel switch and the second and fourth adapters must be connected to the bottom Fibre Channel switch.

- ③ 3. Verify that the connection between the host and the switch has been made:

SHOW CONNECTIONS

You should see a display similar to that in Example Display 20.

Example Display 20

```

Connection Unit
Name      Operating system  Controller  Port   Address  Status Offset
!NEWCON00      WINNT           THIS        1      210013   online  0
  HOST_ID=nnnn-nnnn-nnnn-nnnn . . . . ADAPTER_ID=nnnn-nnnn-nnnn-nnnn
!NEWCON01      WINNT           OTHER       1      200013   online  0
  HOST_ID=nnnn-nnnn-nnnn-nnnn . . . . ADAPTER_ID=nnnn-nnnn-nnnn-nnnn
    
```

Rename the Host Connections

- ① To better identify which hosts you are working with, Compaq recommends that you rename the host connections, using a meaningful connection name for each. Each HBA appears as a connection. An HBA can be identified by its WWN, which you recorded when you installed the HBAs, and which appears in the connection description.

Initially, each connection is named !NEWCONxx. It is much easier to track connections if the connection names are meaningful, like “HostB1.”

IMPORTANT: If you use scripting to automate failover and failback operations, do not use dashes (hyphens) as separators in your naming convention—use underscores instead. Dashes are not allowed by the Perl scripting language.

- ① 1. We suggest that you use the worksheet in Figure 4–4 on page 4–25 when renaming your hosts.
- ① 2. When you have completed the worksheet, rename the connections:

```
RENAME !NEWCONxx TargetHostConnectionNameX
```

```
RENAME !NEWCONxx TargetHostConnectionNameY
```

```
Example: rename !NEWCONxx HostB1
```

```
Example: rename !NEWCONxx HostB2
```

- ① 3. Set the operating system for each connection to NetWare:

```
SET TargetHostConnectionNameX OPERATING_SYSTEM = NETWARE
```

```
Example: set HostB1 operating_system = netware
```

```
Example: set HostB2 operating_system = netware
```

- ① 4. When you have finished renaming your host connections, issue the following command to see your settings:

```
SHOW CONNECTIONS
```

You should see a display similar to that in Example Display 21.

Example Display 21

Connection Unit

Name	Operating system	Controller	Port	Address	Status	Offset
HostB1	NETWARE	THIS	1	210013	online	0
HOST_ID=nnnn-nnnn-nnnn-nnnn ADAPTER_ID=nnnn-nnnn-nnnn-nnnn						
HostB2	NETWARE	OTHER	1	200013	online	0

HOST_ID=nnnn-nnnn-nnnn-nnnn ADAPTER_ID=nnnn-nnnn-nnnn-nnnn

Update Switch Zones

The switch zones created earlier must be updated with the host connection information (refer to Chapter 6, “Configuring the Optional Advanced DRM Solutions,” for detailed information on zone creation):

1. On the top fabric, add the host connection to the zone that contains port 1 of the top target controller.
2. On the bottom fabric, add the host connection to the zone that contains port 1 of the bottom target controller.

Your NetWare host is now configured to use DRM. Execute this procedure for each NetWare host present at the target site. After configuring the target site hosts, go to the section “Configure the Controllers at the Initiator Site” on page 4–56.

Sun Solaris

1. Before beginning this procedure, make sure that your host is up to date with Solaris OS patches. For supported revision levels, go to the DRM website:

<http://www.compaq.com/products/sanworks/drm/index.html>

Follow the Software Support Matrices link, then choose your operating system.

Install the Host Bus Adapters

1. You must install at least two HBAs in each host system and they must be installed in pairs. Record the HBA WWID for use later in this section. Refer to the *Compaq StorageWorks 64-Bit PCI-to-Fibre Channel Host Bus Adapter User Guide* for installation instructions.

NOTE: Do not attach your fiber connections to the HBAs until instructed to do so.

WARNING: PCI and Sbus HBAs cannot coexist on the same host

Connect the Host to the SAN

Use your established cabling policy to connect the host to the Fibre Channel switch.

1. Use 50-micron, multi-mode fiber optic cable to connect one adapter of each pair to the top Fibre Channel switch.
2. Use 50-micron, multi-mode fiber optic cable to connect the other adapter of each pair to the bottom Fibre Channel switch.

For example, if there are four adapters in a server, the first and third adapters must be connected to the top Fibre Channel switch and the second and fourth adapters must be connected to the bottom Fibre Channel switch.

Install the Solaris Platform Kit

Install the Solaris platform kit as specified by the instructions in the *Compaq StorageWorks HSG80 ACS Solution Software Version 8.6 for Sun Solaris Installation and Configuration Guide*. Note that DRM requires the following deviations from the procedures when you install the HBAs:

- **Loop Mode.** Disregard references to Loop Mode. Loop Mode is not supported in DRM.
- **Fabric Mode.** Ensure that the top HBA receives the world wide port number (WWPN) of the corresponding top port 1 address of the controller. Ensure that the bottom HBA receives the WWPN of the corresponding bottom port 1 address of the controller.

NOTE: The HBA drivers and the SWCC agent are installed in this section. See Table 3-1 in the *Compaq StorageWorks HSG80 ACS Solution Software Version 8.6 for Sun Solaris Installation and Configuration Guide* for a list of installed packages. SWCC is configured (optional) in a later step.

1. Reboot the hosts using the `reboot -- -r` command.
2. Verify that the connection between the host and the switch has been made:

```
SHOW CONNECTIONS
```

You should see a display similar to that in Example Display 22.

Example Display 22

Connection Unit

Name	Operating system	Controller	Port	Address	Status	Offset
!NEWCON00	WINNT	THIS	1	210013	online	0
HOST_ID=nnnn-nnnn-nnnn-nnnn ADAPTER_ID=nnnn-nnnn-nnnn-nnnn						
!NEWCON01	WINNT	OTHER	1	200013	online	0
HOST_ID=nnnn-nnnn-nnnn-nnnn ADAPTER_ID=nnnn-nnnn-nnnn-nnnn						

Rename the Host Connections

To better identify which hosts you are working with, Compaq recommends that you rename the host connections, using a meaningful connection name for each. Each HBA appears as a connection. An HBA can be identified by its WWN, which you recorded when you installed the HBAs, and which appears in the connection description.

Initially, each connection is named !NEWCONxx. It is much easier to track connections if the connection names are meaningful, like “HostB1.” We suggest that you use the worksheet in Figure 4–4 on page 4–25 to assist in renaming your hosts.

IMPORTANT: If you use scripting to automate failover and failback operations, do not use dashes (hyphens) as separators in your naming convention—use underscores instead. Dashes are not allowed by the Perl scripting language.

1. When you have completed the worksheet, rename the connections:

```
RENAME !NEWCONxx TargetHostConnectionNamex
```

```
RENAME !NEWCONxx TargetHostConnectionNamey
```

```
Example: rename !NEWCON01 HostB1
```

```
Example: rename !NEWCON02 HostB2
```

2. Change the operating system to Solaris for each connection:

```
SET TargetHostConnectionName OPERATING_SYSTEM = SUN
```

```
Example: set HostB1 operating_system = sun
```

3. When you have finished renaming your host connections, issue the following command to see your settings:

```
SHOW CONNECTIONS
```

You should see a display similar to that in Example Display 23.

Example Display 23

Connection Unit

Name	Operating system	Controller	Port	Address	Status	Offset
HOSTB1	SUN	THIS	1	210013	online	0
HOST_ID=nnnn-nnnn-nnnn-nnnn ADAPTER_ID=nnnn-nnnn-nnnn-nnnn						
HOSTB2	SUN	OTHER	1	200113	online	0
HOST_ID=nnnn-nnnn-nnnn-nnnn ADAPTER_ID=nnnn-nnnn-nnnn-nnnn						

Update Switch Zones

The switch zones created earlier must be updated with the host connection information (refer to Chapter 6, “Configuring the Optional Advanced DRM Solutions,” for detailed information on zone creation):

1. On the top fabric, add the host connection to the zone that contains port 1 of the top target controller.
2. On the bottom fabric, add the host connection to the zone that contains port 1 of the bottom target controller.

Enable Access to the Hosts at the Target Site

1. The target units must have access to the hosts before configuring Secure Path. Enable access by issuing the following command:

```
SET UnitName ENABLE_ACCESS_PATH = TargetHostConnectionNamex,  
TargetHostConnectionNamey
```

Example: `set UnitName enable_access_path = HostB1,HostB2`

Verify the Disks

To run DRM, you must have an even number of HBAs installed in each host system. Follow the procedures outlined here.

1. Reboot the host using the `reboot -- -r` command.
2. Issue the `format` command to verify that the disks are present.

NOTE: There are two entries for each disk, one per HBA. After installing Secure Path for Solaris, there will be only *one* entry per disk.

Install Secure Path for Solaris Software

- ① Install the Secure Path software as specified in the current version of the *SANworks Secure Path for Sun Solaris Installation and Reference Guide*.

After configuring Secure Path, reboot the host using the `reboot -- -r` command.

Reverify the Disks

- ① Issue the format command again to verify that disks are present. There must be only one entry for each disk.

NOTE: All target numbers are stored in *IdLite.conf*.

Configure SWCC Agent (Optional)

- ① You may now configure SWCC. Refer to the *Compaq StorageWorks HSG80 ACS Solution Software Version 8.6 for Sun Solaris Installation and Configuration Guide* for details on the configuration utility. Invoke the configuration utility with the command:

```
/opt/steam/bin/install.h
```

Disable Access to the Hosts at the Target Site

- ① To prevent the target host from writing to any remote copy set targets, disable access by issuing the command:

```
SET UnitName DISABLE=ALL
```

Issue this command for each unit.

NOTE: This step is for remote copy set (RCS) LUNs only.

Additional Setup

- ① Reboot the host using the `reboot -- -r` command.

The format command does not now show any disks from the HSG80 subsystem.

Your Solaris is now configured to use DRM. Follow this procedure for each Solaris host present at the target site. After configuring the target site hosts, go to the section “Configure the Controllers at the Initiator Site” on page 4–56.

Configure the Controllers at the Initiator Site

- ▶ Before you configure the controllers at the initiator site, be sure to:
 - Identify the WWN on the HBAs.
 - Select the name to assign to the initiator site. This name must be different from the one you assigned to the target site.

To get your DT system up and running, you must set up and configure the controllers by executing the following procedure.

- ▶ 1. Ensure that all enclosures, Fibre Channel switches, and power distribution units (PDUs), are powered off.
- ▶ 2. Plug all rack PDU power cords into the main power receptacles.
- ▶ 3. Make sure that you have a serial connection ready to each of the controllers.
- ▶ 4. Power on all PDUs.
- ▶ 5. Ensure that the Fibre Channel switches are powered on, but not cabled.
- ▶ 6. Turn on the enclosures.

NOTE: When the enclosures are turned on, the controllers will boot only if the PCMCIA cards are installed. If there are no cards in the controller slots, insert them now, and then press the **Reset** button. Refer to the *Compaq StorageWorks HSG80 ACS Solution Software Version 8.6 Installation and Configuration Guide*, for your operating system, for complete instructions that show how to properly seat the controller cards.

- ▶ 7. Establish a CLI connection to the top controller. Refer to the *Compaq StorageWorks HSG80 Array Controller ACS V8.6 Maintenance and Service Guide* for instructions.
- ▶ 8. Verify that all controllers are on and functional by observing the CLI prompt on the maintenance port of each controller.

NOTE: Unless otherwise specified, all operations may be conducted from the top controller (controller A1).

- ▶ 9. Verify that the controllers are properly set up:

```
SHOW THIS_CONTROLLER
```

You should see a display similar to that in Example Display 24.

Example Display 24

```

Controller:

    HSG80 ZG8nnnnnnn Software V86P-4, Hardware  E03
    NODE_ID          = nnnn-nnnn-nnnn-nnnn
    ALLOCATION_CLASS  = 0
    SCSI_VERSION     = SCSI-2
    Not configured for dual-redundancy
        Controller misconfigured -- other controller present
    Device Port SCSI address 7
    Time: NOT SET
    Command Console LUN is disabled

Host PORT_1:

    Reported PORT_ID = nnnn-nnnn-nnnn-nnnn
PORT_1_TOPOLOGY  = OFFLINE (offline)

Host PORT_2:

    Reported PORT_ID = nnnn-nnnn-nnnn-nnnn
PORT_2_TOPOLOGY  = OFFLINE (offline)
    NOREMOTE_COPY

Cache:

    512 megabyte write cache, version 0012
    Cache is GOOD
    No unflushed data in cache
    CACHE_FLUSH_TIMER = DEFAULT (10 seconds)

Mirrored Cache:

    Not enabled

Battery:

    FULLY CHARGED
    Expires:
    NOCACHE_UPS

Controller misconfigured. Type SHOW THIS_CONTROLLER
    
```

- ▶ 10. Verify that the subsystem WWN, also called the *NODE_ID*, is set (if zeros are displayed, the name is not set):

- If the name is set, go to step 13.
- If the WWN has not been assigned to the controller, you must obtain the name before proceeding.

NOTE: The subsystem's WWN and checksum are located on a sticker on top of the frame that houses the controllers, EMU, PVA, and cache modules. This sticker also includes a checksum, which is required to verify that the WWN is valid. If no label is present, contact your Compaq customer service representative for assistance. Refer to the *Compaq StorageWorks HSG80 ACS Solution Software Version 8.6 Installation and Configuration Guide*, for your operating system, for more information on WWNs. Each subsystem's WWN begins with 5000 and ends in zero; for example, 5000-1FE1-FF0C-EE00. The controller port IDs are derived from the WWN.



CAUTION: Never set two subsystems to the same WWN; data corruption will occur.



11. After the WWN has been located, assign it to the controller:

```
SET THIS_CONTROLLER NODE_ID=node_ID checksum
```

You should see a display similar to that in Example Display 25.

Example Display 25

```
Warning 4000: A restart of this controller is required before all the
parameters modified will take effect
%CER--HSG80> --09-FEB-1999 10:07:54-- Restart of this controller required
Restart of this controller required
```



12. Issue a SHOW THIS_CONTROLLER command to verify that the WWN is set.

You should see a display similar to that in Example Display 26.

Example Display 26

Controller:

```
HSG80 ZG8nnnnnnn Software V851-P, Hardware E03
NODE_ID           = 5000-nnnn-nnnn-nnn0
ALLOCATION_CLASS = 0
SCSI_VERSION     = SCSI-2
Not configured for dual-redundancy
Controller misconfigured -- other controller present
```

```
Device Port SCSI address 7
Time: NOT SET
Command Console LUN is disabled
```

- ▶ 13. Configure the controllers for multiple-bus failover mode:

```
SET MULTIBUS_FAILOVER COPY=THIS_CONTROLLER
```

This command automatically restarts the “other” controller.

A %LFL and %EVL prompt is displayed. Refer to the *Compaq StorageWorks HSG80 Array Controller ACS V8.6 Maintenance and Service Guide* for more details on these reports.

- ▶ 14. Verify that the setting from step 13 has been applied:

```
SHOW THIS_CONTROLLER FULL
```

Check the display to verify that the controllers have been configured to support multiple-bus failover mode.

You should see a display similar to that in Example Display 27.

Example Display 27

Controller:

```
HSG80 ZG8nnnnnnn Software V851-P, Hardware E03
NODE_ID           = nnnn-nnnn-nnnn-nnnn
ALLOCATION_CLASS   = 0
SCSI_VERSION      = SCSI-2
Configured for MULTIBUS_FAILOVER with ZG8nnnnnnn
  In dual-redundant configuration
Device Port SCSI address 7
Time: NOT SET
Command Console LUN is lun 0 (NOIDENTIFIER)
```

NOTE: These settings are applied automatically to controller B2. It is not necessary to repeat these steps on controller B2.

- ▶ 15. You must select the SCSI mode for the controllers. Some operating systems support only one SCSI mode. For more information, go to the DRM website:

<http://www.compaq.com/products/sanworks/drm/index.html>

Follow the Software Support Matrices link, then choose your operating system.

Set SCSI-3 mode:

```
SET THIS SCSI=SCSI-3
```

NOTE: For OpenVMS, set alloclass and identifier:

```
SET THIS ALLOCATION_CLASS = 1
```

```
SET THIS IDENTIFIER = 99
```

Setting this switch causes the host to load the SYS\$DRIVER, which provides the GG devices. The value range is 1 - 99.

NOTE: D0 (D-zero) can no longer be used as a device LUN in SCSI-3 mode.

Set SCSI-2 mode:

```
SET THIS SCSI=SCSI-2
```

- ▶ 16. Change your controller prompts to identify which controller you are working on:

```
SET THIS_CONTROLLER PROMPT="InitiatorControllerNameTop> "
```

```
SET OTHER_CONTROLLER PROMPT="InitiatorControllerNameBottom> "
```

```
Example: set this_controller prompt="BuildingATop> "
```

```
Example: set other_controller prompt="BuildingABottom> "
```

NOTE: This step takes effect immediately.

- ▶ 17. Check to see whether mirrored write-back cache is enabled:

```
SHOW THIS_CONTROLLER
```

If mirrored write-back cache is not enabled, you should see a display similar to that in Example Display 28.

Example Display 28

```
.  
. .  
. .
```

Mirrored Cache:

Not enabled

```
.  
. .  
. .
```

If mirrored write-back cache is not enabled, issue the following CLI command:

```
SET THIS_CONTROLLER MIRRORED_CACHE
```

The controllers restart after mirrored write-back cache is set. You should see %LFL and %EVL displays.

NOTE: It may take up to five minutes after restart for diagnostics to complete on the cache. The controller rejects this command until the cache check is complete. If the command is rejected, do not restart the controllers. Wait a few minutes and then try again.

- ▶ 18. After the controllers restart, confirm that mirrored write-back cache is enabled:

```
SHOW THIS_CONTROLLER
```

You should see a display similar to that in Example Display 29.

Example Display 29

```
.  
. .  
.  
Mirrored Cache:  
  
    256 megabyte write cache, version 0012  
    Cache is GOOD  
    No unflushed data in cache  
  
. .  
. .  
.
```

NOTE: These settings are applied automatically to controller B2. It is not necessary to repeat these steps on controller B2.

- ▶ 19. Set the fabric topology for each port on both controllers by issuing the following CLI commands:

NOTE: You may be prompted to restart the controllers after each command, but you do not need to restart the controllers until all topologies have been set.

```
SET THIS_CONTROLLER PORT_1_TOPOLOGY=FABRIC  
SET THIS_CONTROLLER PORT_2_TOPOLOGY=FABRIC  
SET OTHER_CONTROLLER PORT_1_TOPOLOGY=FABRIC  
SET OTHER_CONTROLLER PORT_2_TOPOLOGY=FABRIC
```

- ▶ 20. Issue the following CLI command:

```
SET LOG NOLOG
```

NOTE: You can ignore the error message ERROR B020:No Logdisk is Configured if it appears.

- ▶ 21. Restart the controllers in the order shown:

```
RESTART OTHER_CONTROLLER
```

```
RESTART THIS_CONTROLLER
```

NOTE: There may be a brief delay before control is returned.

- ▶ 22. After the controllers have restarted, verify that the topology is set correctly:

```
SHOW THIS_CONTROLLER
```

```
SHOW OTHER_CONTROLLER
```

You should see a display similar to that in Example Display 30.

Example Display 30

```
.  
. .  
Host PORT_1:  
  Reported PORT_ID = nnnn-nnnn-nnnn-nnnn  
  . . . . . PORT_1_TOPOLOGY = FABRIC (up)  
Host PORT_2:  
  Reported PORT_ID = nnnn-nnnn-nnnn-nnnn  
  . . . . . PORT_2_TOPOLOGY = FABRIC (up)  
  NOREMOTE_COPY
```

- ▶ 23. You are now ready to enable DRM. Issue the following CLI command:

```
SET THIS_CONTROLLER REMOTE_COPY=InitiatorControllerName
```

Example: `set this_controller remote_copy=BuildngA`

NOTE: Be sure to specify a meaningful `InitiatorControllerName`, such as a name that reflects the initiator node's location. Do not use "local" or "remote"; they are reserved keywords. The name can be up to eight characters and must be unique to all of your controllers.

After entering this CLI command, you should see a series of %LFL and %EVL displays; the controllers automatically restart.

- ▶ 24. Verify that these settings are in place:

```
SHOW THIS_CONTROLLER
```

You should see a display similar to that in Example Display 31.

Example Display 31

```

.
.
.
Host PORT_2:
    Reported PORT_ID = nnnn-nnnn-nnnn-nnnn
    PORT_2_TOPOLOGY = FABRIC (offline)
    REMOTE_COPY = BUILDNGA
.
.
.

```

Configure Storage at the Initiator Site

This section explains how to configure storage for remote replication.

Devices and Stagesets

- ▶ Before you can configure the storage for remote replication, you must add disks, create stagesets, and create units. Follow the instructions in the *Compaq StorageWorks HSG80 ACS Solution Software Version 8.6 Installation and Configuration Guide*, for your operating system, but note the restrictions listed in Table 4-1 on page 4-3 of this document.

NOTE: D0 (D-zero) can no longer be used as a device LUN in SCSI-3 mode.

NOTE: The target site must have exactly the same stageset configuration, unit configuration, and physical layout for remote copy sets as the initiator site. Non-RCS LUNs may be different at the two sites.

Create Storage Units

Before issuing this ADD UNIT command, you must already have created any stagesets required. Refer to the *Compaq StorageWorks HSG80 ACS Solution Software Version 8.6 Installation and Configuration Guide*, for your operating system, for detailed information on configuring units.

- ▶ 1. Issue the following command to create storage units and to disable all access as the units are being created.

```
ADD UNIT UnitName StorageSetName
```

- ▶ 2. If you want to use units that were created with a different ADD command, disable all host access to those units by issuing the following command:

```
SET UnitName DISABLE_ACCESS_PATH=ALL
```

Repeat this step for each unit.

NOTE: For OpenVMS, set device ID on all units:

```
SET UNIT IDENTIFIER = value
```

Example: set dl id = 1

This becomes the VMS device ID for DGA1.

- ▶ 3. After all units have been created, verify that the access on each unit is set to *none*:

```
SHOW UNITS FULL
```

You should see a display similar to that in Example Display 32.

Example Display 32

```

LUN                                     Uses                               Used by
-----
D10 . . . . . DISK1000
  LUN ID:      nnnn-nnnn-nnnn-nnnn-nnnn-nnnn-nnnn-nnnn
NOIDENTIFIER
Switches:
RUN . . . . . NOWRITE_PROTECT READ_CACHE'
READAHEAD_CACHE . . . . . WRITEBACK_CACHE
MAXIMUM_CACHED_TRANSFER_SIZE = 32

Access:
  NONE
State:
  ONLINE to this controller
  Not reserved
  NOPREFERRED_PAT
Size: nnnnnnnn blocks
Geometry (C/H/S): ( 7000 / 20 / 254 )
.
.
.

```

- ▶ 4. Distribute the units by setting their preferred path. Use either of the following CLI commands:

```
SET UnitName PREFERRED_PATH=THIS_CONTROLLER
```

or

```
SET UnitName PREFERRED_PATH=OTHER_CONTROLLER
```

- ▶ 5. After configuring the units, restart the controllers in the order shown (otherwise, the preferred path settings will not go into effect):

```
RESTART OTHER_CONTROLLER
```

```
RESTART THIS_CONTROLLER
```

- ▶ 6. Once the controllers have restarted, ensure that your storage settings are in place:

```
SHOW UNITS FULL
```

You should see a display similar to that in Example Display 33.

Example Display 33

```

LUN                                     Uses                               Used by
-----
D10 . . . . . DISK1000
  LUN ID:      nnnn-nnnn-nnnn-nnnn-nnnn-nnnn-nnnn-nnnn
NOIDENTIFIER
Switches:
RUN . . . . . NOWRITE_PROTECT READ_CACHE`
READAHEAD_CACHE . . . . . WRITEBACK_CACHE
MAXIMUM_CACHED_TRANSFER_SIZE = 32

Access:
  NONE
State:
  ONLINE to this controller
  Not reserved
PREFERRED_PATH = THIS
Size: nnnnnnnn blocks
Geometry (C/H/S): ( 7000 / 20 / 254 )

```

⋮

Cable the Initiator Site

This section explains how to cable controllers and switches at the initiator site.

Connect Fiber Optic Cables Between Controllers and Fibre Channel Switches

Use your established cabling policy to connect the host to the Fibre Channel switch.

- ▶ 1. Make sure that you have installed all required GBICs into each of the Fibre Channel switches.
- ▶ 2. Use 50-micron, multi-mode fiber optic cable to connect port 1 of the top controller to the top Fibre Channel switch.
- ▶ 3. Use 50-micron, multi-mode fiber optic cable to connect port 2 of the top controller to the top Fibre Channel switch.
- ▶ 4. Use 50-micron, multi-mode fiber optic cable to connect port 1 of the bottom controller to the bottom Fibre Channel switch.
- ▶ 5. Use 50-micron, multi-mode fiber optic cable to connect port 2 of the bottom controller to the bottom Fibre Channel switch.

NOTE: You should see an illuminated green LED on the switch as soon as the cable is inserted at both ends. This verifies that there is a good connection.

Example:

- a. Insert short-wave GBICs in ports 2 and 4 of the top and bottom Fibre Channel switches.
- b. Connect a 50-micron, multi-mode fiber optic cable from port 1 of the top controller to port 2 of the top Fibre Channel switch (as shown by callout 1 of Figure 4-5).
- c. Connect a second 50-micron, multi-mode fiber optic cable from port 2 of the top controller to port 4 of the top Fibre Channel switch (as shown by callout 2 of Figure 4-5).

- d. Connect a third 50-micron, multi-mode fiber optic cable from port 1 of the bottom controller to port 2 of the bottom Fibre Channel switch (as shown by callout 3 of Figure 4–5).
- e. Connect a fourth 50-micron, multi-mode fiber optic cable from port 2 of the bottom controller to port 4 of the bottom Fibre Channel switch (as shown by callout 4 of Figure 4–5).

Figure 4–5 illustrates this example. In this figure, the controllers are on the left and the switches are on the right.

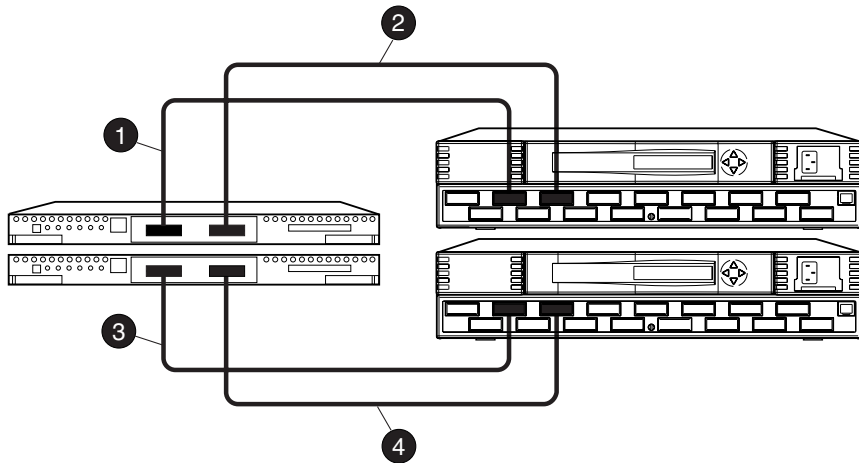

CXO7089A

- ❶ Cable from port 1 of the top controller to port 2 of the top Fibre Channel switch
- ❷ Cable from port 2 of the top controller to port 4 of the top Fibre Channel switch
- ❸ Cable from port 1 of the bottom controller to port 2 of the bottom Fibre Channel switch
- ❹ Cable from port 2 of the bottom controller to port 4 of the bottom Fibre Channel switch

Figure 4–5: Cabling between the controllers and the Fibre Channel switches

Connect the Initiator Site to the External Fiber Link

- ▶ Locate the connection points at the initiator site that link the initiator site to the target site. Execute the procedure in the next section if you have long wave or very long distance GBICs. Otherwise, go the section “Other Transport Modes” on page 4–68.

Long Wave or Very Long Distance GBICs

- ▶ 1. Install long wave or very long distance GBIC now if not previously installed.
- ▶ 2. Connect a single-mode, 9-micron fiber optic cable from the long wave or very long distance GBIC in the top switch to one connection point.
- ▶ 3. Connect another single-mode, 9-micron fiber optic cable from the long wave or very long distance GBIC in the bottom switch to the other connection point.

Other Transport Modes

- ▶ For a list of the most current software, firmware, patches, drivers, and so on, for each of the supported operating systems in your DRM solution, go to the following website:

<http://www.compaq.com/products/sanworks/drm/index.html>

Follow the Software Support Matrices link, then choose your operating system.

The initiator site is now physically linked to the target site. See Figure 4–6 for a diagram of the cabling.

NOTE: You can verify that switches and ports are connected as you have documented them by issuing the *nbrStateShow* switch command. Issue the *topologyShow* switch command to reveal whether you have more than one fiber optic cable between the switches at each site.

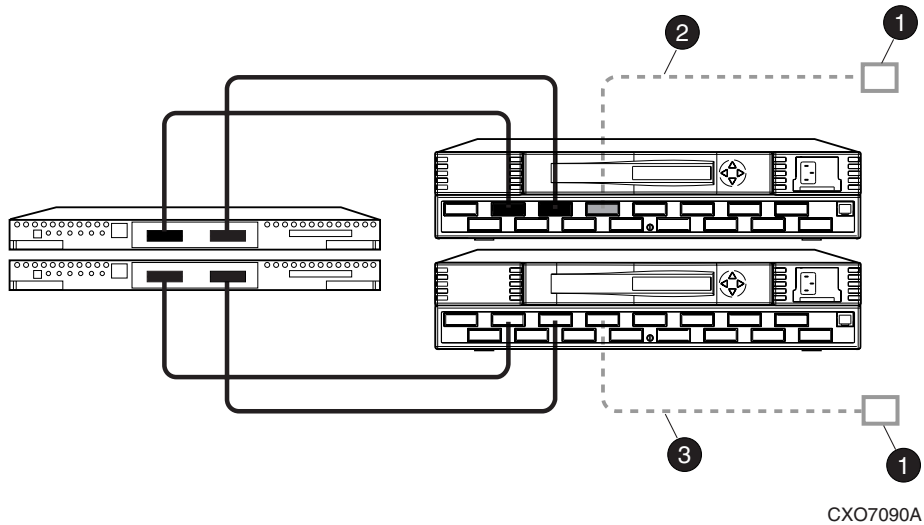

- ❶ Connection points to target site
- ❷ Cable from port 6 of the top switch to one connection point
- ❸ Cable from port 6 of the bottom switch to the other connection point

Figure 4–6: Cabling from the initiator to the target site

Create Switch Zones

Switch zones must now be created and updated. See Chapter 6, “Configuring the Optional Advanced DRM Solutions,” for more information on creating zones.

- ▶ 1. Create a zone on the top fabric that contains port 1 of the top controller. This zone will later contain initiator host connections as well.
- ▶ 2. Add port 2 of the top controller to the top ISL zone created at the target site. This zone must now contain port 2 of the initiator controller and port 2 of the target controller.
- ▶ 3. Create a zone on the bottom fabric that contains port 1 of the bottom controller. This zone will later contain initiator host connections as well.

- ▶ 4. Add port 2 of the bottom controller to the bottom ISL zone created at the target site. This zone must now contain port 2 of the initiator controller and port 2 of the target controller.

There should now be a total of six zones (three per fabric). There must be two ISL zones (one per fabric), two initiator host zones (one per fabric), and two target host zones (one per fabric).

NOTE: If any target hosts will be using non-remote copy sets on the initiator, they must be added to the zones in step 1 and step 3.

Create Remote Copy Sets

This section explains how to establish remote copy sets (RCSs).

Prepare the Initiator Site

- ▶ Before creating the RCS, create the connections between the initiator and target sites by issuing the following CLI command:

```
ADD REMOTE RCS200 D200 TargetControllerName\D200
```

Example: `add remote rcs200 d200 BuildngB\D200`

NOTE: This command fails (because a unit number must be in the range 0 - 199) with the error message “Initiator unit specified not found.” However, it does properly create and name the connections.

Create Connections from the Target Site

- ⊙ 1. Before creating the remote copy set, create the connections between the target and initiator sites:

```
ADD REMOTE RCS200 D200 InitiatorControllerName\D200
```

Example: `add remote rcs200 d200 BuildngA\D200`

NOTE: This command fails with the error message “Initiator unit specified not found”. However, it does create and name the connections.

- ⊙ 2. Verify that the target has access to the initiator controller:

```
SHOW CONNECTIONS
```

This command shows all the connections; verify that the following are included: *InitiatorControllerA*, *InitiatorControllerB*, *InitiatorControllerC*, *InitiatorControllerD*.

- 3. The target units must allow access to the controllers at the initiator site. Enable access with the following CLI command:

```
SET UnitName ENABLE_ACCESS_PATH=(InitiatorControllerConnectionA,
InitiatorControllerConnectionB, InitiatorControllerConnectionC,
InitiatorControllerConnectionD)
```

Example: set d1 enable_access_path=(BuildngAA, BuildngAB, BuildngAC, BuildngAD)

Repeat this command for each UnitName.

- 4. Issue a SHOW UNITS FULL command to verify that the correct access path has been created for each unit.

Create Remote Copy Sets from the Initiator Site

- 1. Verify that the initiator has access to the target controller:

```
SHOW CONNECTIONS
```

This command shows all the connections; verify that the following are included: *InitiatorControllerA*, *InitiatorControllerB*, *InitiatorControllerC*, *InitiatorControllerD*.

- 2. The initiator controllers must have access to the controllers at the target site. Enable access by issuing the following CLI command:

```
SET UnitName ENABLE_ACCESS_PATH=(TargetControllerConnectionA,
TargetControllerConnectionB, TargetControllerConnectionC,
TargetControllerConnectionD)
```

Example: set d1 enable_access_path=(BuildngBA, BuildngBB, BuildngBC, BuildngBD)

NOTE: Repeat this command for each UnitName.

- 3. To create remote copy sets, issue the CLI command below. When you issue this command, the controllers copy all data from the initiator unit to the target unit. This process is called *normalization*.

NOTE: Remote copy set names are limited to alphanumeric characters, the underscore and the hyphen.

```
ADD REMOTE RemoteCopySetName initiatorUnitName
TargetControllerName\TargetUnitName
```

Example: add remote rcs1 d1 BuildngB\D1

Repeat this step for all units that you want to become remote copy sets. It is not necessary to repeat this step at the target site.

IMPORTANT: If you use scripting to automate failover and failback operations, do not use dashes (hyphens) as separators in your naming convention—use underscores instead. Dashes are not allowed by the Perl scripting language.

Repeat for each remote copy set.

You will see a confirmation message on your terminal, as shown in Example Display 34. If the instance code on your screen matches the instance code in this example, you have performed this command correctly.

Example Display 34

```
%EVL--Initra > --13-JAN-1946 05:01:56 (time not set)-- Instance Code: 0E010064
Template: 144.(90)
Power On Time: 0. Years, 36. Days, 6. Hours, 45. Minutes, 22. Seconds
Controller Model: HSG80
Serial Number: ZG8nnnnnnnn Hardware Version: Enn(2B)
Software Version: V86P
Informational Report
Target Controller Board Serial Number: "      ZG8nnnnnnnn"
Initiator WWLID: nnnn-nnnn-nnnn-nnnn-nnnn-nnnn-nnnn-nnnn
Initiator Node Name: "BuildngA"
Initiator Unit Number: n.(nnnnnnnn)
Target WWLID: nnnn-nnnn-nnnn-nnnn-nnnn-nnnn-nnnn-nnnn
Target Node Name: "BuildngB"
Target Unit Number: n.(nnnnnnnn)
Remote Copy Set Name: "RCS1"
Instance Code: 0E010064
```

Set Failsafe at the Initiator Site (Optional)

When failsafe is set and the remote copy set loses the target member, no further I/O is allowed to the initiator member and an error is returned to the host. This is known as a *failsafe locked* condition and prevents the system from writing data that is not protected from a disaster by a copy at the target site.

- ▶ 1. If you choose to set failsafe, issue the following command:

```
SET RemoteCopyName ERROR_MODE=FAILSAFE
Example: Set rcs1 error_mode=failsafe
```

NOTE: When you set failsafe, all remote copy sets must be in a normal or normalizing state. If remote copy sets are copying when you set failsafe, your command is rejected until the remote copy sets return to normal mode.

- ▶ 2. To remove the failsafe lock from a remote copy set and resume normal operation, issue the following CLI command:

```
SET RemoteCopyName ERROR_MODE=NORMAL
```

Example: `set rcs1 error_mode=normal`

You can also use this procedure for remote copy sets where a DT-safe condition is not required.

NOTE: If the error mode is set to normal and there is no target member, the remote copy set is no longer considered DT-safe.

Create Write History Log Units and Association Sets (Optional)

- ▶ In the examples in this section, hypothetical disks 50100 and 60100 are the mirrorset for the log disk. The write history log unit is MIR_D1LOG. The association set name is AS_D1. The association set uses remote copy set name RCS1.

Create a Write History Log Unit

- ▶ 1. Create a mirrorset for the write history log disk:

```
ADD MIRRORSET MirrorsetName DiskName1 DiskName2
```

Example: `add mirrorset mir_d1log disk50100 disk60100`

IMPORTANT: If you use scripting to automate failover and failback operations, do not use dashes (hyphens) as separators in your naming convention—use underscores instead. Dashes are not allowed by the Perl scripting language.

NOTE: To minimize the number of devices used for logging, you can create and use one-member mirrorsets. The logged data is not protected, since it is written only to one disk. However, all of this data is also written to the initiator unit. In the case of a log disk failure, you would incur a full normalization, rather than a mini-merge, when access to the target is reestablished. The command to create a one-member mirrorset is the same as that above, except only one disk is listed. Example: `ADD MIRRORSET MIR_D1LOG DISK 50100`.

- ▶ 2. Initialize the mirrorset:

```
INITIALIZE MirrorsetName
```

Example: `initialize mir_d1log`

- ▶ 3. Verify that you have created a mirrorset:

`SHOW StoragesetType`

Example: `show mir_d1log`

You should see a display similar to that in Example Display 35.

Example Display 35

Name	Storageset	Uses	Used by
MIR_D1LOG	mirrorset	DISK50100	DISK60100

- ▶ 4. Present the log unit to the controller:

`ADD UNIT UnitName MirrorsetName`

Example: `add unit d10 mir_d1log`

- ▶ 5. Verify that the controller recognizes the log unit:

`SHOW UNITS`

You should see a display similar to that in Example Display 36.

Example Display 36

LUN	Uses	Used by
D10	MIR_D1LOG	

Create Association Sets and Assign a Write History Log Unit

- ▶ 1. Create an association set:

`ADD ASSOCIATIONS AssociationSetName RemoteCopySetName`

Example: `add associations as_d1 rc_d1`

IMPORTANT: If you use scripting to automate failover and failback operations, do not use dashes (hyphens) as separators in your naming convention—use underscores instead. Dashes are not allowed by the Perl scripting language.

NOTE: You can add additional members to the association set by issuing the following CLI command:

`SET AssociationSetName ADD=RemoteCopySetName`

- ▶ 2. Disable node access to the write history log unit:

```
SET UnitNumber DISABLE_ACCESS_PATH= ALL
```

 Example: set d10 disable_access_path= all
- ▶ 3. Disable mirrored write-back cache on write history log units:

```
SET UnitNumber NOWRITEBACK_CACHE
```

 Example: set d10 nowriteback_cache
- ▶ 4. Verify that you have disabled access and mirrored write-back cache:

```
SHOW UnitNumber
```

 Example: show d10

You should see a display similar to that in Example Display 37.

Example Display 37

```

LUN                                     Uses                               Used by
-----
D10                                     MIR_D1LOG
LUN ID:          6000-1FE1-0001-3B10-0009-9130-8044-0066
IDENTIFIER = 10
Switches:
RUN              NOWRITE_PROTECT          READ_CACHE
READAHEAD_CACHE  NOWRITEBACK_CACHE
MAXIMUM_CACHED_TRANSFER_SIZE = 32
Access:
    None
State:
    ONLINE to this controller
    Not reserved
    PREFERRED_PATH = THIS_CONTROLLER
Size:          35556389 blocks
Geometry (C/H/S): ( 7000 / 20 / 254 )
  
```

- ▶ 5. Assign the write history log unit to the association set:

```
SET AssociationSetName LOG_UNIT = D10
```

Example: `set as_d1 log_unit = d10`

NOTE: If you choose to set the `fail_all` property of the association set, make sure that all of the remote copy sets in the association are set to failsafe error mode. If you do this, however, you will not be able to use a write history log unit.

- ▶ 6. Check to see the switch status of the association set:

```
SHOW AssociationSetName
```

Example: `show as_d1`

You should see a display similar to that in Example Display 38.

Example Display 38

Name	Association	Uses	Used by
AS_D1	association	RC_D1	

Switches:

```
NOFAIL_ALL  
NOORDER_ALL  
LOG_UNIT = D10 (No data logged)
```

- ▶ 7. You may set the `FAIL_ALL` or `ORDER_ALL` properties of the association set now, if desired, by issuing the following CLI commands:

```
SET AssociationSetName FAIL_ALL
```

```
SET AssociationSetName ORDER_ALL
```

NOTE: If you choose to set the `fail_all` property of the association set, make sure that all of the remote copy sets in the association set are set to failsafe error mode. If you choose to use failsafe error mode, you cannot use a log unit.

Configure the Host at the Initiator Site

This section describes how to set up your host systems at the initiator site. Follow the procedures for each operating system present in your SAN:

- “Compaq OpenVMS” on page 4–77
- “Compaq Tru64 UNIX” on page 4–80
- “HP-UX” on page 4–84
- “IBM AIX” on page 4–87
- “Microsoft Windows NT and Windows 2000” on page 4–97
- “Novell NetWare” on page 4–101
- “Sun Solaris” on page 4–106

Compaq OpenVMS

- ▶ Before beginning this procedure, make sure that your host is up to date with service packs and patches. For supported revision levels, go to the DRM website:

<http://www.compaq.com/products/sanworks/drm/index.html>

Follow the Software Support Matrices link, then choose your operating system.

Install the Host Bus Adapters

- ▶ You must install at least two HBAs in each host system. Record the HBA WWID for use later in this section. Refer to the *Compaq StorageWorks 64-Bit PCI-to-Fibre Channel Host Bus Adapter User Guide* for installation instructions.

NOTE: Do not attach your fiber connections to the HBAs until instructed to do so.

Install SWCC (Optional)

- ▶ You may now install SWCC. For detailed information about SWCC, including installation, refer to the *Compaq StorageWorks Command Console Version 2.4 User Guide*.

Additional Setup

- ▶ You will need the latest TIMA kit, which is identified at the DRM website:

<http://www.compaq.com/products/sanworks/drm/index.html>

Follow the Software Support Matrices link, then choose your operating system.

Connect the Host to the SAN

Use your established cabling policy to connect the host to the Fibre Channel switch.

- ▶ 1. Use 50-micron, multi-mode fiber optic cable to connect one adapter of each pair to the top Fibre Channel switch.
- ▶ 2. Use 50-micron, multi-mode fiber optic cable to connect the other adapter of each pair to the bottom Fibre Channel switch.

Example: If there are four adapters in a server, the first and third adapters must be connected to the top Fibre Channel switch; the second and fourth adapters must be connected to the bottom Fibre Channel switch.

- ▶ 3. Verify that the connection between the host and the switch has been made:

```
SHOW CONNECTIONS
```

You should see a display similar to that in Example Display 39.

Example Display 39

```
Connection Unit
Name      Operating system  Controller  Port   Address   Status  Offset
!NEWCON00  VMS                THIS        1      210013   online  0
          HOST_ID=nnnn-nnnn-nnnn-nnnn . . . . ADAPTER_ID=nnnn-nnnn-nnnn-nnnn
!NEWCON01  VMS                OTHER        1      200013   online  0
          HOST_ID=nnnn-nnnn-nnnn-nnnn . . . . ADAPTER_ID=nnnn-nnnn-nnnn-nnnn
```

Rename the Host Connections

To better identify the hosts, Compaq recommends that you rename the host connections using a meaningful name for each. Each HBA appears as a connection. An HBA can be identified by its WWN, which you recorded when you installed the HBAs, and which appears in the connection description.

Initially, each connection is named !NEWCONxx. It is easier to track connections if the connection names are meaningful, like “HostA1.”

IMPORTANT: If you use scripting to automate failover and failback operations, do not use dashes (hyphens) as separators in your naming convention—use underscores instead. Dashes are not allowed by the Perl scripting language.

- ▶ 1. We suggest that you use the worksheet in Figure 4–4 on page 4–25 when renaming hosts.

- ▶ 2. When you have completed the worksheet, rename the connections:

```
RENAME !NEWCONxx InitiatorHostConnectionNameX
RENAME !NEWCONxx InitiatorHostConnectionNameY
Example: rename !NEWCONxx HostA1
Example: rename !NEWCONxx HostA2
```

- ▶ 3. Set the operating system for each connection to OpenVMS:

```
SET InitiatorHostConnectionNameX OPERATING_SYSTEM=VMS
Example: set HostA1 operating_system = vms
Example: set HostA2 operating_system = vms
```

- ▶ 4. When you have finished naming your host connections, issue the following command to verify your new settings:

```
SHOW CONNECTIONS
```

You should see a display similar to that in Example Display 40.

Example Display 40

```
Connection Unit
Name      Operating system  Controller  Port   Address  Status Offset
HostA1    VMS THIS          1          210013  online  0
          HOST_ID=nnnn-nnnn-nnnn-nnnn . . . . ADAPTER_ID=nnnn-nnnn-nnnn-nnnn
HostA2    VMS OTHER          1          200013  online  0
          HOST_ID=nnnn-nnnn-nnnn-nnnn . . . . ADAPTER_ID=nnnn-nnnn-nnnn-nnnn
```

Update Switch Zones

The switch zones created at the target site must be updated with the host connection information (refer to Chapter 6, “Configuring the Optional Advanced DRM Solutions,” for detailed information on zone creation):

- ▶ 1. On the top fabric, add the host connection to the zone that contains port 1 of the top initiator controller.
- ▶ 2. On the bottom fabric, add the host connection to the zone that contains port 1 of bottom the initiator controller.

Enable Access to the Hosts at the Initiator Site

- ▶ The initiator units must have access to the hosts. Enable access with the following CLI command:

```
SET UnitName ENABLE_ACCESS_PATH=(InitiatorHostConnectionNamex,  
InitiatorHostConnectionNamey)
```

Example: `set unitname enable_access_path=(HostA1,HostA2)`

Repeat this step for all units.

Your OpenVMS host is now configured to use DRM. Follow this procedure for each OpenVMS host present at the initiator site. After configuring the initiator site hosts, go to the section “Additional Host Configuration” on page 4-111.

Compaq Tru64 UNIX

- ▶ Before beginning this procedure, make sure that your host is up to date with service packs and patches. For supported revision levels, go to the DRM website:

<http://www.compaq.com/products/sanworks/drm/index.html>

Follow the Software Support Matrices link, then choose your operating system.

Install the Host Bus Adapters

- ▶ You must install at least two HBAs in each host system. Record the HBA WWID for use later in this section. Refer to the *Compaq StorageWorks 64-Bit PCI-to-Fibre Channel Host Bus Adapter User Guide* for installation instructions.

NOTE: Do not attach your fiber connections to the HBAs until instructed to do so. The driver is installed in the following step.

Install the Host Bus Adapter Driver

- ▶ The EMX driver for Tru64 UNIX is already installed. Issue the following command to verify that the driver version and the firmware version are at supported levels:

```
# cat /usr/adm/messages |grep KGPSA
```

You should see a display similar to that in Example Display 41.

Example Display 41

```
Apr 19 14:19:37 tru002 vmunix: KGPSA-CA : Driver Rev 1.30 :  
F/W Rev 3.81A4(2.01A0) : wwn 1000-0000-c924-fe8c
```

Multipath Software

- ▶ Tru64 UNIX has native multipath support with path auto-detection. No further configuration is required.

Install SWCC (Optional)

- ▶ You may now install SWCC. For detailed information about SWCC, including installation, refer to the *Compaq StorageWorks Command Console Version 2.4 User Guide*.

Connect the Host to the SAN

Use your established cabling policy to connect the host to the Fibre Channel switch.

- ▶ 1. Use 50-micron, multi-mode fiber optic cable to connect one adapter of each pair to the top Fibre Channel switch.
- ▶ 2. Use 50-micron, multi-mode fiber optic cable to connect the other adapter of each pair to the bottom Fibre Channel switch.

Example: If there are four adapters in a server, the first and third adapters must be connected to the top Fibre Channel switch. The second and fourth adapters must be connected to the bottom Fibre Channel switch.

- ▶ 3. Verify that the host has logged into the fabric:

```
SHOW CONNECTIONS
```

You should see a display similar to that in Example Display 42.

Example Display 42

```

Connection Unit
Name          Operating system  Controller  Port   Address   Status Offset
!NEWCON00    WINNT                THIS        1      210013    online 0
             HOST_ID=nnnn-nnnn-nnnn-nnnn . . . . ADAPTER_ID=nnnn-nnnn-nnnn-nnnn
!NEWCON01    WINNT                OTHER       1      200013    online 0
             HOST_ID=nnnn-nnnn-nnnn-nnnn . . . . ADAPTER_ID=nnnn-nnnn-nnnn-nnnn
    
```

Rename the Host Connections

To better identify the hosts you are working with, Compaq recommends that you rename the host connections using a meaningful connection name for each. Each HBA appears as a connection. An HBA can be identified by its WWN, which you recorded when you installed the HBAs, and which appears in the connection description.

Initially, each connection is named !NEWCONxx. It is much easier to track connections if the connection names are meaningful, like “HostA1.”

IMPORTANT: If you use scripting to automate failover and failback operations, do not use dashes (hyphens) as separators in your naming convention—use underscores instead. Dashes are not allowed by the Perl scripting language.

- ▶ 1. Use the worksheet in Figure 4–4 on page 4–25 to assist in renaming your hosts.

- ▶ 2. When you have completed the worksheet, rename the connections:

```

RENAME !NEWCONxx InitiatorHostConnectionNameX
RENAME !NEWCONxx InitiatorHostConnectionNameY
Example: rename !NEWCONxx HostA1
Example: rename !NEWCONxx HostA2
    
```

- ▶ 3. Set the operating system for each connection to Tru64 UNIX:

```

SET TargetHostConnectionName OPERATING_SYSTEM=TRU64_UNIX
Example: set HostA1 operating_system=tru64_unix
    
```

- ▶ 4. When you have finished renaming your host connections, verify your settings:

```
SHOW CONNECTIONS
```

You should see a display similar to that in Example Display 43.

Example Display 43

Connection Unit

Name	Operating system	Controller	Port	Address	Status	Offset
HostA1	Tru64_UNIX	THIS	1	210013	online	0
		HOST_ID=nnnn-nnnn-nnnn-nnnn		ADAPTER_ID=nnnn-nnnn-nnnn-nnnn		
HostA2	Tru64_UNIX	OTHER	1	200013	online	0
		HOST_ID=nnnn-nnnn-nnnn-nnnn		ADAPTER_ID=nnnn-nnnn-nnnn-nnnn		

Update Switch Zones

The switch zones created at the target site must be updated with the host connection information (refer to Chapter 6, “Configuring the Optional Advanced DRM Solutions,” for detailed information on zone creation):

- ▶ 1. On the top fabric, add the host connection to the zone that contains port 1 of the top initiator controller.
- ▶ 2. On the bottom fabric, add the host connection to the zone that contains port 1 of the bottom initiator controller.

Enable Access to the Hosts at the Initiator Site

- ▶ 1. The initiator units must have access to the hosts. Enable access with the following command:

```
SET UnitName ENABLE_ACCESS_PATH=InitiatorHostConnectionNamex,
InitiatorHostConnectionNamey
```

Example: `set UnitName enable_access_path=HostA1,HostA2`

NOTE: There must be two paths per host. Repeat this sequence for each host.

- ▶ 2. From a terminal window on the host, issue the following commands to recognize the new units and assign device special file numbers:

```
# hwmgr - scan comp - cat scsi_bus
# hwmgr - show scsi
```

Your Tru64 UNIX host is now configured to use DRM. Follow this procedure for each Tru64 UNIX host present at the initiator site. After configuring the initiator site hosts, go to the section “Additional Host Configuration” on page 4–111.

HP-UX

- ▶ Before starting this procedure, make sure that your host is up to date with service packs and patches. For supported revision levels, go to the DRM website:

<http://www.compaq.com/products/sanworks/drm/index.html>

Follow the Software Support Matrices link, then choose your operating system.

Existing Fibre Channel HP-UX Configurations

- ▶ Refer to the *Compaq SANworks Secure Path V3.0 for HP-UX Installation and Reference Guide* for information on:
 - Changing from SCSI-2 to SCSI-3, Command Console LUN (CCL) behavior
 - Changing HBAs and switch modes from QuickLoop to Fabric.

Install the Host Bus Adapters

- ▶ You must install at least two HBAs in each host system. HBAs must be installed in pairs.

Power down your HP-UX host and install the HBAs in any of the free PCI slots. Install the HBA device driver if needed.

Refer to vendor's adapter service and user guide for installation instructions.

Connect the Host to the SAN

Use your established cabling policy to connect the host to the Fibre Channel switches:

- ▶ 1. Use 50-micron, multi-mode fiber optic cable to connect one adapter of each pair to the top fabric.
- ▶ 2. Use 50-micron, multi-mode fiber optic cable to connect the other adapter of each pair to the bottom fabric.

Example: If there are four adapters in a server, the first and third adapters must be connected to the top Fibre Channel switch. The second and fourth adapters must be connected to the bottom Fibre Channel switch.

Rename the Host Connections

To better identify which hosts you are working with, Compaq recommends that you rename the host connections, using a meaningful connection name for each. Each HBA appears as a connection on the HSG80. An HBA can be identified by its WWN in the connection description. To find the WWN of each HBA, refer to Chapter 7, “Troubleshooting.”

Initially, each connection on the HSG80 is named !NEWCONxx. It is much easier to track connections if the connection names are meaningful, like "HostA1."

IMPORTANT: If you use scripting to automate failover and failback operations, do not use dashes (hyphens) as separators in your naming convention-use underscores instead. Dashes are not allowed by the Perl scripting language.

- ▶ 1. Use the worksheet in Figure 4–4 on page 4–25 to assist in renaming your hosts. You may reproduce this worksheet as needed.
- ▶ 2. When you have completed the worksheet, rename the connections:

```
RENAME !NEWCONxx TargetHostConnectionNameX
RENAME !NEWCONxx TargetHostConnectionNameY
Example: rename !NEWCONxx HostA1
Example: rename !NEWCONxx HostA2
```
- ▶ 3. Change the operating system for each connection to HP-UX:

```
SET !NEWCONxx operating_system=hp
```
- ▶ 4. After you have renamed the host connections, issue the following command to see the new settings:

```
SHOW CONNECTIONS
```

Update Switch Zones

The switch zones created earlier must be updated with the host connection information:

- ▶ 1. On the top fabric, add the host connection to the zone that contains port 1 of the top target controller.
- ▶ 2. On the bottom fabric, add the host connection to the zone that contains port 1 of the bottom target controller.

Enable Access to the Hosts at the Initiator Site

- ▶ The initiator hosts must have access to the units. Enable access with the following command:

```
SET UnitName ENABLE_ACCESS_PATH=InitiatorHostConnectionNamex,  
InitiatorHostConnectionNamey
```

```
Example: set UnitName enable_access_path=HostA1,HostA2
```

Repeat this step for each unit.

Install the Secure Path Fibre Channel Host Bus Adapter Device Driver

- ▶ Install the Secure Path Fibre Channel HBA device driver according to the instructions in the *Compaq SANworks Secure Path V3.0 for HP-UX Installation and Reference Guide*.

Verify the Disks

- ▶ 1. Verify that the disks are present by issuing the following command:

```
ioscan -fnCdisk
```

The output should be similar to that shown in Example Display 44.

Example Display 44

Class	I	H/W Path	Driver	S/W State	H/W Type	Description
disk 0	0	0/0/1/1.2.0	sdisk	CLAIMED	DEVICE	SEAGATE ST39204LC
		/dev/dsk/c1t2d0		/dev/rdisk/c1t2d0		
disk 1	0	0/0/255.0.0.0	sdisk	CLAIMED	DEVICE	HSG80 LUN
		0x60001FE100080D100009834019820144				
		/dev/dsk/c8t0d0		/dev/rdisk/c8t0d0		

NOTE: If the device special files i.e., /dev/dsk/c8t0d0 /dev/rdisk/c8t0d0, are not displayed then issue command `insf -e` to install special files and repeat the command `ioscan -fnCdisk`.

Configure the SWCC Agent (Optional)

- ▶ The SWCC Agent may now be installed and configured. Refer to the *Compaq StorageWorks HSG80 ACS Solution Software Version 8.6 for HP-UX Installation and Configuration Guide* for installation instructions.

Additional Setup

- ▶ You may now configure volume groups, logical volumes, and file systems on any non-remote copy set LUNs on the storage arrays using normal HP-UX procedures.
Your HP-UX host is now configured to use DRM. Repeat this procedure for each HP-UX host present at your initiator site. After configuring the initiator site hosts, go to the section “Additional Host Configuration” on page 4–111.

IBM AIX

- ▶ Before beginning this procedure, make sure that your host is up to date with service packs and patches. For supported revision levels, go to the DRM website:

<http://www.compaq.com/products/sanworks/drm/index.html>

Follow the Software Support Matrices link, then choose your operating system.

Install the Host Bus Adapters

- ▶ You must install at least two HBAs in each host system. HBAs must be installed in pairs. You may install a maximum of six adapters per host, but two adapter pairs must not share the same unit on the RAID system.

Power down your AIX host and install the HBAs in any of the free PCI slots. The HBAs work in either a 32-bit or 64-bit PCI card slot. Record the HBA WWID for use later in this section.

NOTE: Do not attach your fiber connections to the HBAs at this time and do not install the AIX driver that comes with the Cambex HBA. The driver is installed in the following step.

Install the Secure Path Fibre Channel Host Bus Adapter Device Driver and the AIX Platform Kit

- ▶ The following describes the preferred method for installing the *StorageWorks* platform kit software for IBM AIX and Secure Path Secure Path Fibre Channel HBA device driver software on your AIX servers. Use these instructions, in the given order, instead of the installation instructions in the platform kit (*Compaq StorageWorks HSG80 ACS*

Version 8.6 Solution Software for IBM AIX Installation and Configuration Guide) and Secure Path software (Compaq SANworks Secure Path V2.0 for IBM AIX Installation and Reference Guide).

▶ **New Installation**

Follow these instructions if you are performing a new installation of the *StorageWorks* platform kit for AIX and Secure Path.

▶ ***New Installation Assumptions***

- All components are not connected.
- AIX operating system version is V4.3.3.
- Cambex is the Fibre Channel adapter.
- Secure Path is V2.0A.
- Solution platform kit is V8.6.
- HSG80 ACS code is V8.6-4P.
- Storage subsystem is pre-configured with or without a CCL LUN.
- Mode is SCSI-2 or SCSI-3, with the LUN connection type set as WINNT.
- Host bus adapters (HBAs) are installed in pairs.
- No volume groups, logical volumes, or file systems are created.
- Clustering services is not installed.

HBA Limitations

HBAs have the following limitations:

- Addressing of LUNS is limited to 16 devices. This limitation must be considered when planning the sub-system storage configuration.
- Configuring a CCL LUN will leave 15 LUN addresses.

Installation Steps

- ▶ 1. Install Fibre Channel HBAs. Do not connect fiber cables at this time.
NOTE: The maximum number of HBAs per host is 6. Refer to IBM's PCI Adapter Placement Reference document.
- ▶ 2. Power up or boot server.

▶ 3. Load *StorageWorks* platform kit for AIX v8.6:

- a. Load platform CD into CD drive.
- b. Enter the following commands:

```
#mkdir /cdrom
#mount -v cdrfs -r /dev/cd0 /cdrom
#cd /cdrom
#./INSTALL (follow the prompts)
```

The system will not find any DEC HSG80 RAID array devices at this time.

The option of installing the SWCC Agent will be presented at this time. Choose **Yes**. Installation of the SWCC Agent will begin. When installation is complete, you will be asked if you wish to start the Agent:

- Answer **Yes** if the host will be used as an SWCC Agent.
- Answer **No** if the host will not be used as an SWCC Agent.

Refer to the *Compaq StorageWorks HSG80 ACS Solution Software Version 8.6 for IBM AIX Installation and Configuration Guide* for additional information on this process.

```
#umount /cdrom
```

▶ 4. Remove platform kit Fibre Channel driver v1.5.11.1 with the following commands:

```
#installp -u PC1000.driver.obj
#lslpp -l PC1000.driver.obj
```

▶ 5. Load Secure Path for IBM V2.0A, Fibre Channel driver v1.5.15.1:

- a. Load Secure Path CD into CD drive.

- b. Enter the following commands:

```
#mkdir /mnt
#mount -v cdrfs -r /dev/cd0 /mnt
#mkdir /tmp/driver
#cp /mnt/driver/PC1000SP.image /tmp/driver
#cd /tmp/driver
#installp -acd PC1000SP.image all
#lslpp -l PC1000.driver.obj
#umount /mnt
```

- ▶ 6. Run Configuration Manager to add Fibre Channel HBA to the configuration database. Enter the following commands:

```
#cfgmgr -v
#lsdev -Cc adapter
```

- ▶ 7. Connect fiber cables to HBAs.

- ▶ 8. Run Configuration Manager to add hdisks / HSG80 Raid Array to the configuration database. Enter the following commands:

```
#cfgmgr -v
#lsdev -Cc disk
```

The system will find HSG80 Raid Array devices at this time. If CCL is enabled on the HSG80 the server will find a Command Console LUN.

Multiple instances of the Command Console LUN hdisks may be displayed. Remove all of the higher numbered hdisks, keeping only the lowest numbered hdisk of the Command Console LUN. Remove the hdisks with the following command:

```
#rmdev -dl hdiskx
```

where x is the number of the hdisk to be removed.

- ▶ 9. Run the *StorageWorks* Install Agent, if required:

```
#cd /usr/stgwks2
# ./stgwks_aix.sh
```

Choose **Option 1**.

- ▶ 10. Create Volume Groups, Logical Volumes, and Files Systems.

- ▶ 11. Configure clustering services (if required).
- ▶ 12. Check the status of the host bus adapters periodically.

Upgrade Installation

If you are currently using an AIX server in transparent failover mode, and you wish to upgrade to ACS Version 8.6-4P in a DRM environment, follow these instructions.

Upgrade Installation Assumptions

- All components are connected.
- AIX OS is upgraded to V4.3.3.
- Cambex Fibre Channel adapters are installed.
- A version of Secure Path is loaded.
- A version of the Solution platform kit is loaded, or has been upgraded.
- HSG80 ACS code is being upgraded to V8.6-4P.
- Storage subsystem is pre-configured with or without a CCL LUN, in SCSI-2 or SCSI-3 mode, with the LUN connection type set as WINNT.
- HBAs are installed in pairs.
- Volume groups, logical volumes, and file systems created.
- Clustering services may be installed.

HBA Limitations

HBAs have the following limitations:

- Addressing of LUNS is limited to 16 devices. This limitation must be considered when planning the sub-system storage configuration.
- Configuring a CCL LUN will leave 15 LUN addresses.

Installation Steps

- ▶ 1. Stop all I/O.
- ▶ 2. Stop clustering services (if running).
- ▶ 3. Stop the *StorageWorks* Agent (if running).

- ▶ 4. Backup all Volume Groups (highly recommended).
- ▶ 5. Unmount and perform file system check on all logical volumes, varyoff, and export volume groups, with the following commands:

```
#umount /dev/(logical_volume_name)
#fsck /(file_system_name)
#varyoffvg (volume_group_name)
```
- ▶ 6. Remove all hdisks associated with DEC HSG80 RAID array from the configuration database with the following commands:

```
#lsdev -Cc disk
#rmdev -dl hdiskx (x is the hdisk number)
```
- ▶ 7. Remove all Fibre Channel adapters from the configuration database with the following commands:

```
#lsdev -Cc adapter
#rmdev -dl scsix (x is the Cambex adapter number)
```
- ▶ 8. Uninstall the Fibre Channel driver with the following command:

```
#installp -u PC1000.driver.obj
```
- ▶ 9. Disconnect all Fibre Channel adapter cables.
- ▶ 10. If adding an additional Cambex Fibre Channel adapter, shutdown the server with the following command:

```
#shutdown
```
- ▶ 11. Install additional Fibre Channel Host Bus Adapters (if required). Do not connect fiber cables at this time.

NOTE: The maximum number of HBAs per host is 6. Refer to IBM's PCI Adapter Placement Reference document.
- ▶ 12. Power up or boot server.
- ▶ 13. Load *StorageWorks* platform kit for AIX v8.6:
 - a. Load platform CD into CD drive.

- b. Enter the following commands:

```
#mkdir /cdrom
#mount -v cdrfs -r /dev/cd0 /cdrom
#cd /cdrom
#./INSTALL (follow the prompts)
```

The system will not find any DEC HSG80 RAID array devices at this time.

The option of installing the SWCC Agent will be presented at this time. Choose **Yes**. Installation of the SWCC Agent will begin. When installation is complete, you will be asked if you wish to start the Agent:

- Answer **Yes** if the host will be used as an SWCC Agent.
- Answer **No** if the host will not be used as an SWCC Agent.

Refer to the *Compaq StorageWorks HSG80 ACS Solution Software Version 8.6 for IBM AIX Installation and Configuration Guide* for additional information on this process.

```
#umount /cdrom
```

- ▶ 14. Remove platform kit Fibre Channel driver v1.5.11.1 with the following commands:

```
#installp -u PC1000.driver.obj
#lslpp -l PC1000.driver.obj
```

- ▶ 15. Load Secure Path for IBM V2.0A, Fibre Channel driver v1.5.15.1:

- a. Load Secure Path CD in to CD drive.

- b. Enter the following commands:

```
#mkdir /mnt
#mount -v cdrfs -r /dev/cd0 /mnt
#mkdir /tmp/driver
#cp /mnt/driver/PC1000SP.image /tmp/driver
#cd /tmp/driver
#installp -acd PC1000SP.image all
#lslpp -l PC1000.driver.obj
#umount /mnt
```

- ▶ 16. Run Configuration Manager to add Fibre Channel HBA to the configuration database with the following commands:

```
#cfgmgr -v  
#lsdev -Cc adapter
```

- ▶ 17. Connect fiber cables to HBAs.

- ▶ 18. Run Configuration Manager to add hdisks or HSG80 Raid Array to the configuration database with the following commands:

```
#cfgmgr -v  
#lsdev -Cc disk
```

The system will find HSG80 Raid Array devices at this time. If CCL is enabled on the HSG80 the server will find a Command Console LUN.

Multiple instances of the Command Console LUN hdisks may be displayed. Remove all of the higher numbered hdisks, keeping only the lowest numbered hdisk of the Command Console LUN. Remove the hdisks with the following command:

```
#rmdev -dl hdiskx
```

where x is the number of the hdisk to be removed.

- ▶ 19. Run the *StorageWorks* Install Agent, if required:

```
#cd /usr/stgwks2  
# ./stgwks_aix.sh
```

Choose **Option 1**.

- ▶ 20. Reestablish volume groups, logical volumes, and files systems with the following commands:

```
#varyonvg (volume_group_name)  
#mount /dev/(logical_volume__name)
```

- ▶ 21. Reestablish clustering services (if required).

- ▶ 22. Check the status of the host bus adapters periodically.

Connect the Host to the SAN

Use your established cabling policy to connect the host to the Fibre Channel switches:

- ▶ 1. Use 50-micron, multi-mode fiber optic cable to connect one adapter of each pair to the top fabric.
- ▶ 2. Use 50-micron, multi-mode fiber optic cable to connect the other adapter of each pair to the bottom fabric.

Example: If there are four adapters in a server, the first and third should be connected to the top fabric; and the second and fourth adapters should be connected to the bottom fabric.

Rename the Host Connections

To better identify which hosts you are working with, Compaq recommends that you rename the host connections, using a meaningful connection name for each. Each HBA appears as a connection. An HBA can be identified by its WWN, which you recorded when you installed the HBAs, and which appears in the connection description.

Initially, each connection is named !NEWCONxx. It is much easier to track connections if the connection names are meaningful, like “HostA1.”

IMPORTANT: If you use scripting to automate failover and failback operations, do not use dashes (hyphens) as separators in your naming convention—use underscores instead. Dashes are not allowed by the Perl scripting language.

- ▶ 1. We suggest that you use the worksheet in Figure 4–4 on page 4–25 when renaming your hosts.
- ▶ 2. When you have completed the worksheet, rename the connections:

```
RENAME !NEWCONxx TargetHostConnectionNamex
```

```
RENAME !NEWCONxx TargetHostConnectionNamey
```

Example: rename !NEWCONxx HostA1

Example: rename !NEWCONxx HostA2

- ▶ 3. Change the operating system for each connection to IBM AIX (use WINNT for this function):

```
SET !NEWCONxx operating_system=WINNT
```

- ▶ 4. After you have renamed the host connections, verify the new settings:

```
SHOW CONNECTIONS
```

Update Switch Zones

The switch zones created earlier must be updated with the host connection information:

- ▶ 1. On the top fabric, add the host connection to the zone that contains port 1 of the top target controller.
- ▶ 2. On the bottom fabric, add the host connection to the zone that contains port 1 of the bottom target controller.

Enable Access to the Hosts at the Initiator Site

- ▶ The initiator hosts must have access to the units. Enable access with the following command:

```
SET UnitName ENABLE_ACCESS_PATH=InitiatorHostConnectionNamex,  
InitiatorHostConnectionNamey
```

Example: `set UnitName enable_access_path=HostA1,HostA2`

Repeat this step for each unit.

Verify the Disks

- ▶ Verify that disks are present by issuing the following commands:

```
cfgmgr -v  
lsdev -Cc disk
```

The `cfgmgr` command configures `hdisks` for all LUNs that your system can access on the storage arrays.

The output of the `lsdev` command should be similar to that shown in Example Display 45.

Example Display 45

```
hdisk0 Available 10-60-00-6,0 16 Bit LVD SCSI Disk Drive  
hdisk1 Available 20-58-00-8,0 DEC HSG80 Command Console LUN  
hdisk2 Available 20-58-00-8,7 DEC HSG80 RAID Array
```

In this example:

- `hdisk0` represents the internal hard drive of your AIX host.

- hdisk1 represents the Command Console LUN (CCL).
- hdisk2 represents a single unit or LUN (LUN 7 as denoted by the last number in the line 20-58-00-8,7).

Configure the SWCC Agent (Optional)

- ▶ The SWCC Agent may now be installed and configured. Refer to the *Compaq StorageWorks HSG80 ACS Solution Software Version 8.6 for IBM AIX Installation and Configuration Guide* for installation instructions.

Additional Setup

- ▶ You may now configure volume groups, logical volumes, and file systems on the storage arrays using normal AIX procedures.

Your AIX host is now configured to use DRM. Repeat this procedure for each AIX host present at the initiator site. After configuring the initiator site hosts, go to the section “Additional Host Configuration” on page 4–111.

Microsoft Windows NT and Windows 2000

- ▶ Before beginning this procedure, make sure that your host is up to date with service packs and patches. For supported revision levels, go to the DRM website:

<http://www.compaq.com/products/sanworks/drm/index.html>

Follow the Software Support Matrices link, then choose your operating system.

Ensure that the hosts are not connected to the Fibre Channel switches at any point during this procedure.

Install the Host Bus Adapters

- ▶ You must install at least two HBAs in each host system. HBAs must be installed in pairs. Record the HBA WWID for use later in this section. Refer to the *Compaq StorageWorks 64-Bit PCI-to-Fibre Channel Host Bus Adapter User Guide* for installation instructions.

NOTE: Do not attach your fiber connections to the HBAs until instructed to do so. The driver is installed in the following step.

Install the Host Bus Adapter Driver

- ▶ Use Device Manager to install the HBA driver. For updated driver version information, go to the DRM website:

<http://www.compaq.com/products/sanworks/drm/index.html>

Follow the Software Support Matrices link, then choose your operating system.

Install Fibre Channel Software

- ▶ Install the Compaq Fibre Channel software on the host. For updated Fibre Channel software version information, go to the DRM website:

<http://www.compaq.com/products/sanworks/drm/index.html>

Follow the Software Support Matrices link, then choose your operating system.

Install Multipath Software

Secure Path must be installed on the host at this point. For installation instructions, refer to the *Compaq SANworks Secure Path Version 3.1 for Microsoft Windows Installation and Reference Guide*.

- ▶ 1. Verify that the Secure Path Agent is installed by going to Administrative Tools and selecting Services. The Secure Path Agent must be set for automatic setup and started.
- ▶ 2. Use the Secure Path Agent Configuration utility to grant access to the client at both the initiator and target sites. To do this, follow these menus:
Start > Programs > Secure Path > Secure Path Cfg.
- ▶ 3. You can set the password and allow client access via the Secure Path Agent Configuration utility.
NOTE: Compaq recommends that you set both the fully qualified and unqualified DNS names as valid, authorized clients.
- ▶ 4. Restart the Secure Path Agent service for changes to take effect.

Install SWCC (Optional)

- ▶ You may now install SWCC. For detailed information about SWCC, including installation, refer to the *Compaq StorageWorks Command Console Version 2.4 User Guide*.

Connect the Host to the SAN

Use your established cabling policy to connect the host to the Fibre Channel switch.

- ▶ 1. Use 50-micron, multi-mode fiber optic cable to connect one adapter of each pair to the top Fibre Channel switch.
- ▶ 2. Use 50-micron, multi-mode fiber optic cable to connect the other adapter of each pair to the bottom Fibre Channel switch.

For example, if there are four adapters in a server, the first and third adapters must be connected to the top Fibre Channel switch and the second and fourth adapters must be connected to the bottom Fibre Channel switch.

- ▶ 3. Verify that the connection between the host and the switch has been made:

```
SHOW CONNECTIONS
```

You should see a display similar to that in Example Display 46.

Example Display 46

Connection Unit

Name	Operating system	Controller	Port	Address	Status	Offset
!NEWCON00	WINNT	THIS	1	210013	online	0
HOST_ID=nnnn-nnnn-nnnn-nnnn ADAPTER_ID=nnnn-nnnn-nnnn-nnnn						
!NEWCON01	WINNT	OTHER	1	200113	online	0
HOST_ID=nnnn-nnnn-nnnn-nnnn ADAPTER_ID=nnnn-nnnn-nnnn-nnnn						
!NEWCON03	WINNT	THIS	1	nnnnnn	online	0
HOST_ID=nnnn-nnnn-nnnn-nnnn ADAPTER_ID=nnnn-nnnn-nnnn-nnnn						
!NEWCON04	WINNT	OTHER	1	nnnnnn	online	0
HOST_ID=nnnn-nnnn-nnnn-nnnn ADAPTER_ID=nnnn-nnnn-nnnn-nnnn						

Rename the Host Connections

To better identify which hosts you are working with, Compaq recommends that you rename the host connections, using a meaningful connection name for each. Each HBA appears as a connection. An HBA can be identified by its WWN, which you recorded when you installed the HBAs, and which appears in the connection description.

Initially, each connection is named !NEWCONxx. It is much easier to track connections if the connection names are meaningful, like “HostA1.”

IMPORTANT: If you use scripting to automate failover and failback operations, do not use dashes (hyphens) as separators in your naming convention—use underscores instead. Dashes are not allowed by the Perl scripting language.

- ▶ 1. We suggest that you use the worksheet in Figure 4–4 on page 4–25 when renaming your hosts.

- ▶ 2. When you have completed the worksheet, rename the connections:

```
RENAME !NEWCONxx TargetHostConnectionNamex
RENAME !NEWCONxx TargetHostConnectionNamey
Example: rename !NEWCONxx HostA1
```

Example: rename !NEWCONxx HostA2

- ▶ 3. Set the operating system for each connection to Windows:

```
SET TargetHostConnectionNamex OPERATING_SYSTEM = WINNT
Example: set HostA1 operating_system = winnt
Example: set HostA2 operating_system = winnt
```

- ▶ 4. When you have finished renaming your host connections, verify your new settings:

```
SHOW CONNECTIONS
```

You should see a display similar to that in Example Display 47.

Example Display 47

```
Connection Unit
Name      Operating system  Controller  Port  Address  Status Offset
BUILDNGBA PPRC_TARGET      THIS       2      online  0
          HOST_ID=nnnn-nnnn-nnnn-nnnn ADAPTER_ID=nnnn-nnnn-nnnn-nnnn
BUILDNGBB PPRC_TARGET      OTHER      2      . . . . . online  0
          HOST_ID=nnnn-nnnn-nnnn-nnnn ADAPTER_ID=nnnn-nnnn-nnnn-nnnn
BUILDNGBC PPRC_INITIATOR   THIS       2      . . . . . online  0
          HOST_ID=nnnn-nnnn-nnnn-nnnn ADAPTER_ID=nnnn-nnnn-nnnn-nnnn
BUILDNGBD PPRC_INITIATOR   OTHER      2      . . . . . online  0
          HOST_ID=nnnn-nnnn-nnnn-nnnn ADAPTER_ID=nnnn-nnnn-nnnn-nnnn
```

```

HOSTA1      WINNT                THIS          1          210013      online    0
      HOST_ID=nnnn-nnnn-nnnn-nnnn ADAPTER_ID=nnnn-nnnn-nnnn-nnnn
HOSTA2      WINNT                OTHER         1          200113      online    0
      HOST_ID=nnnn-nnnn-nnnn-nnnn ADAPTER_ID=nnnn-nnnn-nnnn-nnnn
.
.
.

```

Update Switch Zones

The switch zones created at the target site must be updated with the host connection information (refer to Chapter 6, “Configuring the Optional Advanced DRM Solutions,” for detailed information on zone creation and updating switch zones):

- ▶ 1. On the top fabric, add the host connection to the zone that contains port 1 of the top initiator controller.
- ▶ 2. On the bottom fabric, add the host connection to the zone that contains port 1 of the bottom initiator controller.

Your Windows host is now configured to use DRM. Execute this procedure for each Windows host present at the initiator site. After configuring the initiator site hosts, go to the section “Additional Host Configuration” on page 4-111.

Novell NetWare

- ▶ Before beginning this procedure, make sure that your host is up to date with support packs and patches. For supported revision levels, go to the DRM website:

<http://www.compaq.com/products/sanworks/drm/index.html>

Follow the Software Support Matrices link, then choose your operating system.

Install the Host Bus Adapters

- ▶ You must install at least two HBAs in each host system. Record the HBA WWID for use later in this section. Refer to the *Compaq StorageWorks 64-Bit PCI-to-Fibre Channel Host Bus Adapter User Guide* for installation instructions.

NOTE: Do not attach your fiber connections to the HBAs until instructed to do so. The driver is installed in the following step.

Install the Host Bus Adapter Driver

- ▶ The NetWare HBA multi-path driver is CPQFC.HAM. The driver is installed as part of the Secure Path Agent installation. Refer to the next section.

Install Secure Path Agent

For installation instructions, refer to the *Compaq SANworks Secure Path Version 3.0 for Novell NetWare Installation and Reference Guide*. After installation, execute the following procedure:

- ▶ 1. Verify that the Secure Path Agent is installed by typing the following at the server console:

```
modules cpqspagt
```

If the agent has installed properly, you will see a display of version information.

Ensure that the Secure Path Agent is set for automatic startup. Normally, the Secure Path installation program sets automatic startup by loading *cpqspagt.nlm* in the *autoexec.ncf* file.

- ▶ 2. Use the Secure Path Agent Configuration screen at the server to grant access to the client at both the initiator and target sites. To do this:
 - From the NetWare server, toggle to the Secure Path NLM (NetWare Loadable Module) screen.
 - At the Main menu, select 2) *Client Administration*, then select 2) *Add a Client*.
 - Type the fully qualified DNS name for the client, then press **Enter**.
 - Press **Escape** to return to the Main menu.
- ▶ 3. To set the password and allow client access via the Secure Path Agent Configuration, execute the following procedure:
 - At the Main menu, select 1) *Agent Administration*, then select 1) *Change Password*.
 - Type a password for client access and then retype the password for verification.
 - Press **Escape** to return to the Main menu.

NOTE: Compaq recommends that you set both the fully qualified and unqualified DNS names as valid, authorized clients.

Install Secure Path Manager

- ▶ For installation instructions, refer to the *Compaq SANworks Secure Path Version 3.0 for Novell NetWare Installation and Reference Guide*.

Install SWCC (Optional)

- ▶ You may now install SWCC. For detailed information about SWCC, including installation, refer to the *Compaq StorageWorks Command Console Version 2.4 User Guide*.

Connect the Host to the SAN

Use your established cabling policy to connect the host to the Fibre Channel switch.

- ▶ 1. Use 50-micron, multi-mode fiber optic cable to connect one adapter of each pair to the top Fibre Channel switch.
- ▶ 2. Use 50-micron, multi-mode fiber optic cable to connect the other adapter of each pair to the bottom Fibre Channel switch.

For example, if there are two adapters in a server, the first adapter must be connected to the top Fibre Channel switch and the second adapter must be connected to the bottom Fibre Channel switch.

- ▶ 3. Verify that the connection between the host and the switch has been made:

```
SHOW CONNECTIONS
```

You should see a display similar to that in Example Display 48.

Example Display 48

```
Connection Unit
Name          Operating system    Controller Port    Address    Status Offset
!NEWCON00     WINNT                THIS              1          210013    online    0
HOST_ID=nnnn-nnnn-nnnn-nnnn ADAPTER_ID=nnnn-nnnn-nnnn-nnnn
!NEWCON01     WINNT                OTHER              1          200113    online    0
HOST_ID=nnnn-nnnn-nnnn-nnnn ADAPTER_ID=nnnn-nnnn-nnnn-nnnn
BUILDNGBA PPRC_TARGET      THIS              2 . . . . . online 0
HOST_ID=nnnn-nnnn-nnnn-nnnn ADAPTER_ID=nnnn-nnnn-nnnn-nnnn
BUILDNGBB PPRC_TARGET      OTHER              2 . . . . . online 0
HOST_ID=nnnn-nnnn-nnnn-nnnn ADAPTER_ID=nnnn-nnnn-nnnn-nnnn
```

```

BUILDNGBCPPRC_INITIATOR    THIS      2      . . . . . online 0
    HOST_ID=nnnn-nnnn-nnnn-nnnn ADAPTER_ID=nnnn-nnnn-nnnn-nnnn
BUILDNGBDPPRC_INITIATOR    OTHER      2      . . . . . online 0
    HOST_ID=nnnn-nnnn-nnnn-nnnn ADAPTER_ID=nnnn-nnnn-nnnn-nnnn
    
```

Rename the Host Connections

To better identify which hosts you are working with, Compaq recommends that you rename the host connections, using a meaningful connection name for each. Each HBA appears as a connection. An HBA can be identified by its WWN, which you recorded when you installed the HBAs, and which appears in the connection description.

Initially, each connection is named !NEWCONxx. It is much easier to track connections if the connection names are meaningful, like “HostA1.”

IMPORTANT: If you use scripting to automate failover and failback operations, do not use dashes (hyphens) as separators in your naming convention—use underscores instead. Dashes are not allowed by the Perl scripting language.

- ▶ 1. We suggest that you use the worksheet in Figure 4–4 on page 4–25 when renaming your hosts.

- ▶ 2. When you have completed the worksheet, rename the connections:

```
RENAME !NEWCONxx TargetHostConnectionNameX
```

```
RENAME !NEWCONxx TargetHostConnectionNameY
```

```
Example: rename !NEWCONxx HostA1
```

```
Example: rename !NEWCONxx HostA2
```

- ▶ 3. Set the operating system for each connection to NetWare:

```
SET TargetHostConnectionNameX OPERATING_SYSTEM = NETWARE
```

```
Example: set HostA1 operating_system = netware
```

```
Example: set HostA2 operating_system = netware
```

- ▶ 4. When you have finished renaming your host connections, verify your settings:

```
SHOW CONNECTIONS
```

You should see a display similar to that in Example Display 49.

Example Display 49

```
Connection Unit
```

Name	Operating system	Controller	Port	Address	Status	Offset
HOSTA1	NETWARE	THIS	1	210013	online	0
HOST_ID=nnnn-nnnn-nnnn-nnnn ADAPTER_ID=nnnn-nnnn-nnnn-nnnn						
HOSTA2	NETWARE	OTHER	1	200113	online	0
HOST_ID=nnnn-nnnn-nnnn-nnnn ADAPTER_ID=nnnn-nnnn-nnnn-nnnn						
BUILDNGBA	PPRC_TARGET	THIS	2	online	0
HOST_ID=nnnn-nnnn-nnnn-nnnn ADAPTER_ID=nnnn-nnnn-nnnn-nnnn						
BUILDNGBB	PPRC_TARGET	OTHER	2	online	0
HOST_ID=nnnn-nnnn-nnnn-nnnn ADAPTER_ID=nnnn-nnnn-nnnn-nnnn						
BUILDNGBC	PPRC_INITIATOR	THIS	2	online	0
OST_ID=nnnn-nnnn-nnnn-nnnn ADAPTER_ID=nnnn-nnnn-nnnn-nnnn						
BUILDNGBD	PPRC_INITIATOR	OTHER	2	online	0
HOST_ID=nnnn-nnnn-nnnn-nnnn ADAPTER_ID=nnnn-nnnn-nnnn-nnnn						

Update Switch Zones

The switch zones created at the target site must be updated with the host connection information (refer to Chapter 6, “Configuring the Optional Advanced DRM Solutions,” for detailed information on creating and updating switch zones):

- ▶ 1. On the top fabric, add the host connection to the zone that contains port 1 of the top initiator controller.
- ▶ 2. On the bottom fabric, add the host connection to the zone that contains port 1 of the bottom initiator controller.

Enable Access to the Hosts at the Initiator Site

- ▶ 1. The initiator units must have access to the hosts. Enable access with the following command:

```
SET UnitName ENABLE_ACCESS_PATH=InitiatorHostConnectionNamex,  
InitiatorHostConnectionNamey
```

Example: `set UnitName enable_access_path=HostA1,HostA2`

NOTE: There must be two paths per host. Repeat this sequence for each host.

- ▶ 2. After you have enabled host access to units, issue the following command from the NetWare server console prompt:

```
SCAN FOR NEW DEVICES
```

- ▶ 3. Use ConsoleOne to create traditional partitions and volumes, or use Novell Storage Services (NSS) partions, pools, and logical volumes on the newly-created storage.
- ▶ 4. From the server console prompt, type:

```
MOUNT ALL (for tradional volumes)
```

or

```
MOUNT VolumeName (for NSS logical volumes)
```
- ▶ 5. You are now ready to run Secure Path Manager from your Windows NT or Windows 2000 client machine. Click:

```
Start > Programs > Secure Path > SPM
```

Specify the server and password.
- ▶ 6. The *SANworks* Secure Path Manager screen appears. Left-click each drive icon. The device properties appear in the right pane. Ensure that each drive can be moved successfully between controllers by right clicking the icon and selecting **Move to Other Controller**.

Your NetWare host is now configured for DRM. Follow this procedure for each NetWare host present at the initiator site. After configuring the initiator site hosts, go to the section “Additional Host Configuration” on page 4–111.

Sun Solaris

- ▶ Before beginning this procedure, make sure that your host is up to date with Solaris OS patches. For supported revision levels, go to the DRM website:

<http://www.compaq.com/products/sanworks/drm/index.html>

Follow the Software Support Matrices link, then choose your operating system.

Install the Host Bus Adapters

- ▶ You must install at least two HBAs in each host system. HBAs must be installed in pairs. Record the HBA WWID for use later in this section. Refer to the *Compaq StorageWorks 64-Bit PCI-to-Fibre Channel Host Bus Adapter User Guide* for installation instructions.

NOTE: Do not attach your fiber connections to the HBAs until instructed to do so.

WARNING: PCI and Sbus HBAs cannot coexist on the same host.

Connect the Host to the SAN

Use your established cabling policy to connect the host to the Fibre Channel switch.

- ▶ 1. Use 50-micron, multi-mode fiber optic cable to connect one adapter of each pair to the top Fibre Channel switch.
- ▶ 2. Use 50-micron, multi-mode fiber optic cable to connect the other adapter of each pair to the bottom Fibre Channel switch.

Example: If there are four adapters in a server, the first and third adapters must be connected to the top Fibre Channel switch; the second and fourth adapters must be connected to the bottom Fibre Channel switch.

Install the Solaris Platform Kit

- ▶ 1. Install the Solaris platform kit following the instructions in the *HSG80 ACS Solution Software Version 8.6 for Sun Solaris Installation and Configuration Guide*. Note that DRM requires the following deviations from the steps in this procedure:
 - **Loop Mode.** Disregard references to Loop Mode. Loop Mode is not supported in DRM.
 - **Fabric Mode.** Ensure that the top HBA receives the world wide port number (WWPN) of the corresponding top port 1 address of the controller, and that the bottom HBA receives the WWPN of the corresponding bottom port 1 address of the controller.

NOTE: Install the HBA drivers and the SWCC agent in this step. See Table 3-1 in the *HSG80 ACS Solution Software Version 8.6 for Sun Solaris Installation and Configuration Guide* for the list of installed packages. Configure SWCC (as an option) in a later step.

- ▶ 2. Reboot the host using the `reboot -- -r` command.
- ▶ 3. Verify that the host has logged into the fabric:

```
SHOW CONNECTIONS
```

You should see a display similar to that in Example Display 50.

Example Display 50

```

Connection Unit
Name      Operating system  Controller  Port   Address  Status Offset
!NEWCON00  WINNT              THIS        1      210013   online  0
          HOST_ID=nnnn-nnnn-nnnn-nnnn . . . . ADAPTER_ID=nnnn-nnnn-nnnn-nnnn
!NEWCON01  WINNT              OTHER       1      200013   online  0
          HOST_ID=nnnn-nnnn-nnnn-nnnn . . . . ADAPTER_ID=nnnn-nnnn-nnnn-nnnn
    
```

Rename the Host Connections

To better identify which hosts you are working with, Compaq recommends that you rename the host connections using a meaningful connection name for each. Each HBA appears as a connection. An HBA can be identified by its WWN, which you recorded when you installed the HBAs, and which appears in the connection description.

Initially, each connection is named !NEWCONxx. It is much easier to track connections if the connection names are meaningful, like “HostA1.” We suggest that you use the worksheet in Figure 4–4 on page 4–25 when renaming your hosts.

NOTE: If you use scripting to automate failover and failback operations, do not use dashes (hyphens) as separators in your naming convention—use underscores instead. Dashes are not allowed by the Perl scripting language.

- ▶ 1. When you have completed the worksheet, rename the connections:

```

RENAME !NEWCON01 InitiatorHostConnectionNameX
RENAME !NEWCON02 InitiatorHostConnectionNameY
Example: rename !NEWCONxx HostA1
Example: rename !NEWCONxx HostA2
    
```

- ▶ 2. Set the operating system for each connection to Solaris:

```

SET InitiatorHostConnectionNameX OPERATING_SYSTEM = SUN
Example: set HostA1 operating_system = sun
    
```

- ▶ 3. When you have finished renaming your host connections, verify your new settings:

```
SHOW CONNECTIONS
```

You should see a display similar to that in Example Display 51.

Example Display 51

Connection Unit

Name	Operating system	Controller	Port	Address	Status	Offset
HOSTA1	SUN	THIS	1	210013	online	0
HOST_ID=nnnn-nnnn-nnnn-nnnn ADAPTER_ID=nnnn-nnnn-nnnn-nnnn						
HOSTA2	SUN	OTHER	1	200113	online	0
HOST_ID=nnnn-nnnn-nnnn-nnnn ADAPTER_ID=nnnn-nnnn-nnnn-nnnn						
.						
.						
.						

Update Switch Zones

The switch zones created at the target site must be updated with the host connection information (refer to Chapter 6, “Configuring the Optional Advanced DRM Solutions,” for detailed information on updating switch zones):

- ▶ 1. On the top fabric, add the host connection to the zone that contains port 1 of the top initiator controller.
- ▶ 2. On the bottom fabric, add the host connection to the zone that contains port 1 of the bottom initiator controller.

Enable Access to the Hosts at the Initiator Site

- ▶ The initiator units must have access to the hosts. Enable access with the following command:

```
SET UnitName ENABLE_ACCESS_PATH=InitiatorHostConnectionNamex,  
InitiatorHostConnectionNamey
```

Example: set UnitName enable_access_path=HostA1,HostA2

Repeat this step for all units.

Verify the Disks

To run DRM, you must have an even number of HBAs installed in each host system. Follow the procedures below:

- ▶ 1. Reboot the host using the reboot -- -r command.
- ▶ 2. Issue the format command to verify that disks are present.

NOTE: There are two entries for each disk, one per HBA. After installing Secure Path for Solaris, there will be only *one* entry per disk.

Install Secure Path for Solaris Software

- ▶ Install the Secure Path software as specified in the current version of the *SANworks Secure Path for Sun Solaris Installation and Reference Guide*.

Configure Secure Path with the following command:

```
/opt/CPQswsp/bin/spconfig -o -p /kernel/drv
```

After installing Secure Path, reboot the host using the `reboot -- -r` command.

Reverify the Disks

- ▶ Issue the `format` command again to verify that disks are present. There must be only one entry for each disk.

NOTE: All target numbers are stored in `ldLite.conf`.

Configure the SWCC Agent (Optional)

- ▶ You may now install SWCC. Refer to the *Compaq StorageWorks HSG80 ACS Solution Software Version 8.6 for Sun Solaris Installation and Configuration Guide* for details regarding the configuration utility.

Invoke the configuration utility with the following command:

```
/opt/steam/bin/install.sh
```

Additional Setup

- ▶ Reboot the host using the `reboot -- -r` command.

Your Solaris host is now configured to use DRM. Follow this procedure for each Solaris host present at the initiator site. After configuring the initiator site hosts, go to the section “Additional Host Configuration” on page 4–111.

Additional Host Configuration

This section provides the final configuration procedures, which are to be performed at both the initiator and target sites. The procedures are marked with both symbols: ▶◎.

Install Cluster Server for Windows NT and Windows 2000 (Optional)

- ▶◎ Windows NT and Windows 2000 Fibre Channel cluster software enables two host servers to share a Fibre Channel storage subsystem through a Fibre Channel switch. If a failure occurs on the server, the cluster software detects that failure and initiates a failover. The failed components can be warm-swapped or serviced while the functioning components remain active. This process requires minimal downtime and ensures high availability of data. If you are using Windows NT or Windows 2000 and want to run the cluster option, you may safely install it now.

Install NetWare Cluster Services (NWCS) Version 1.01 (Optional)

- ▶◎ NWCS Fibre Channel cluster software enables two host servers to share a Fibre Channel storage subsystem through a Fibre Channel switch. If a failure occurs on the server, the cluster software detects that failure and initiates a failover. The failed components can be warm-swapped or serviced while the functioning components remain active. This process requires minimal downtime and ensures high availability of data. If you are using NetWare 5.1 and want to run the cluster option, you may safely install it now.

Only non-RCS LUNs are supported.

Documenting Your Configuration

- ▶◎ Keep a copy of both configurations at both sites. Update your records whenever you modify the configuration. Follow the steps outlined below in the sections “Terminal Emulator Session” and “SHOW Commands” to obtain a status of the controllers, association sets, remote copy sets, units, and connections. After you have obtained this information for the initiator site, repeat the steps for the target site.

Terminal Emulator Session

- ▶ 1. Connect a serial cable between a computer's serial port and the HSG80 serial port. The computer can be a desktop or laptop with at least one open serial port.
- ▶ 2. Start a terminal emulator session and connect to the controller. The default connection settings for the controllers are 9600 baud, 8 bits, no parity, 1 stop bit.
- ▶ 3. From the Transfer menu, click **Capture Text**. In the c:\ field of the Capture Text dialog box, type initiator.txt or target.txt.
- ▶ 4. Click **Start**.

SHOW Commands

NOTE: SHOW commands are discussed in detail in Appendix A.

- ▶ 1. To see the full information on this controller, issue the following CLI command:

```
SHOW THIS_CONTROLLER FULL
```

You should see a display similar to that in Example Display 52.

Example Display 52

Controller:

```
HSG80 ZG91412410 Software S050P-0, Hardware E05
NODE_ID           = 5000-1FE1-0001-3AE0
ALLOCATION_CLASS   = 0
SCSI_VERSION      = SCSI-3
Configured for MULTIBUS_FAILOVER with ZG91416136
    In dual-redundant configuration
Device Port SCSI address 6
Time: NOT SET
Command Console LUN is lun 0 (NOIDENTIFIER)
```

Host PORT_1:

```
Reported PORT_ID = 5000-1FE1-0001-3AE1
PORT_1_TOPOLOGY = FABRIC (fabric up)
Address          = 220113
```

Host PORT_2:

```
Reported PORT_ID = 5000-1FE1-0001-3AE2
PORT_2_TOPOLOGY = FABRIC (fabric up)
Address          = 220313
REMOTE_COPY     = BuildngA
```

Cache:

```
256 megabyte write cache, version 0012
Cache is GOOD
No unflushed data in cache
CACHE_FLUSH_TIMER = DEFAULT (10 seconds)
```

Mirrored Cache:

```
256 megabyte write cache, version 0012
Cache is GOOD
No unflushed data in cache
```

Battery:

```
NOUPS
FULLY CHARGED
```

Expires:

Extended information:

```
Terminal speed 9600 baud, eight bit, no parity, 1 stop bit
Operation control: 00000000 Security state code: 75184
Configuration backup disabled
```

-  2. To see the information for all association sets known to the controller pair, issue the following CLI command:

```
SHOW ASSOCIATIONS FULL
```

You should see a display similar to that in Example Display 53 for each association set.

Example Display 53

```

Name                Association                Uses                Used by
-----
AS1                  association                RC1
                   RC2
                   RC3

Switches:
NOFAIL_ALL
NOORDER_ALL
NOLOG_UNIT
    
```

- ▶ 3. To see information for all remote copy sets known to the controller pair, issue the following CLI command:

```
SHOW REMOTE_COPY_SETS FULL
```

You should see a display similar to that in Example Display 54 for each remote copy set.

Example Display 54

```

Name                Uses                Used by
-----
RC1                  remote copy                D1                AS1
Reported LUN ID: 6000-1FE1-0001-3AE0-0009-9141-6136-0038
Switches:
OPERATION_MODE = SYNCHRONOUS
ERROR_MODE      = NORMAL
FAILOVER_MODE   = MANUAL
OUTSTANDING_IOS = 60
Initiator (BuildngA\D1) state:
ONLINE to this controller
Target state:
BuildngB\D1 is NORMAL
    
```

4. To see information for all units configured to the controller, issue the following CLI command:

```
SHOW UNITS FULL
```

You should see a display similar to that in Example Display 55 for each unit.

Example Display 55

```
D2                                     DISK10100 BuildngA\RC2
LUN ID:          6000-1FE1-0001-3AE0-0009-9141-6136-0045
NOIDENTIFIER
Switches:
    RUN                NOWRITE_PROTECT          READ_CACHE
    READAHEAD_CACHE   WRITEBACK_CACHE
    MAXIMUM_CACHED_TRANSFER_SIZE = 1
Access:
    BuildngBA, BuildngBB, BuildngBC, BuildngBD, HOSTA1, HOSTA2
State:
    ONLINE to this controller
    Not reserved
    PREFERRED_PATH = OTHER_CONTROLLER
    Target NORMAL
Size:          17769177 blocks
Geometry (C/H/S): ( 5258 / 20 / 169 )
```

5. To see the connection name, operating system, controller, controller port, adapter ID address, online or offline status, and unit offset, issue the following CLI command:

```
SHOW CONNECTIONS
```

You should see a display similar to that in Example Display 56 for each connection.

Example Display 56

```
Connection Unit
Name      Operating system  Controller  Port  Address  Status Offset
```

```
HostA1 WINNT      THIS      1  634000  OLthis  0
HOST_ID=1000-0000-C921-4B5B ADAPTER_ID=1000-0000-C921-4B5B
```

6. Click Stop to end the Capture Text function. Your work has been saved in the file created in Step 3 in the “Terminal Emulator Session” on page 4–112.
7. Print two copies of this file for future reference. Retain one copy at each site. This hard copy is preferred because the computer or storage containing the on-line copy may not be available during an emergency.
8. Repeat this procedure, “Documenting Your Configuration,” for all subsystems in your configuration.

Configuring the Optional Entry-Level DRM Solutions

This chapter describes the entry-level DRM solutions and explains how to set up and configure them.

NOTE: It is a good idea to keep a copy of this manual at both the initiator and target sites to ensure a successful and identical setup at both sites. Two copies also eliminate confusion if more than one person is configuring DRM.

This chapter covers the following topics:

- Dual Switch Single Site Configuration
- Single Switch Configuration
- Single Fabric Configuration

Overview

Table 5–1 summarizes and compares the entry-level configurations.

Table 5–1: Comparison of Entry-Level Configurations

Configuration	Fully Redundant	Disaster Tolerant	Intersite Link (ISL)	Maximum Separation Distance between Initiator and Target	Zoning Required
Dual Switch Single Site	Yes	No	No	1000 meters	No
Single Switch	No	No	No	1000 meters	Yes
Single Fabric	No	Yes	Yes	Link technology-dependent*	Yes
* Very Long Distance GBIC = up to 100 kilometers Dense Wave Division Multiplex (DWDM) = up to 100 kilometers Asynchronous Transfer Mode (ATM) = unlimited Internet Protocol (IP) = unlimited					

Dual Switch Single Site Configuration

This configuration, shown in Figure 5–1, is designed for environments that need only local data protection in the event of local disaster or that are used as local test beds for operational DRM solutions. This solution uses only two switches, where each switch creates “a fabric in a box,” instead of the multiswitch fabrics supported in full DRM solutions.

NOTE: The maximum separation between host and switch is 500 meters. The maximum separation between hosts is, therefore, 1000 meters or 1 kilometer.

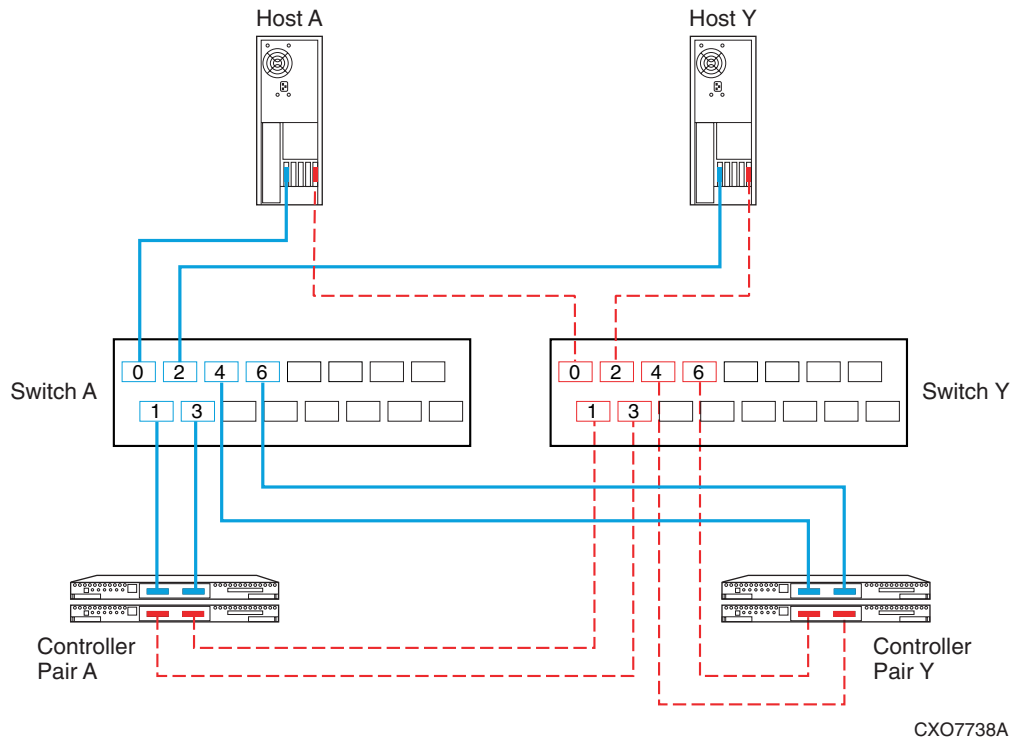

CXO7738A

Figure 5–1: DRM dual switch single site configuration

Because of its design, a DRM Dual Switch Single Site configuration is limited to supporting connections equal to one switch (8 or 16 ports). The maximum configuration is any of the following:

- 16-port switches
 - one pair of arrays and up to twelve servers
 - two pairs of arrays and up to eight servers
 - three pairs of arrays and up to four servers
- 8-port switches
 - one pair of arrays and up to four servers

The limits on the number of servers are specified in the *Compaq StorageWorks Heterogeneous Open SAN Design Reference Guide*.

The HSG80 Array Controller and the server host bus adapter (HBA) use only shortwave gigabit interface converters (GBICs). This means that the DRM Dual Switch Single Site configuration is limited to 500 meters of 50-micron or 200 meters of 62.5-micron multi-mode fiber optic cable between the HBA and either switch and between the controller and either switch. This limits the DRM Dual Switch Single Site configuration to a maximum separation of 1 kilometer, using 50-micron cable (400 meters with 62.5-micron cable), between primary and alternate servers and between primary and alternate storage arrays.

To achieve this maximum distance, Compaq recommends locating the two switches somewhere between the primary site and the alternate site. Both switches should be installed in separate locations with unique fiber paths between the switch and both sites. This will prevent, for example, a single backhoe from cutting both fabrics and isolating the primary and alternate sites from each other. The DRM Dual Switch Single Site configuration is not designed to survive large area natural disasters, like earthquakes, tornadoes, or hurricanes, due to the limited intersite distance.

Setting Up the Dual Switch Single Site DRM Configuration

NOTE: This configuration uses only multi-mode, 50-micron fiber optic cable and is, therefore, limited to 500 meters for any one connection.

Follow the procedures in Chapter 4 to configure a DRM solution, with the following exceptions:

1. Install all required shortwave GBICs into each of the Fibre Channel switches.
2. Make the following controller connections:
 - a. Connect a fiber optic cable from port 1 of the top controller of Controller Pair A to port 1 of Fibre Channel switch A.
 - b. Connect a fiber optic cable from port 2 of the top controller of Controller Pair A to port 3 of Fibre Channel switch A.
 - c. Connect a fiber optic cable from port 1 of the bottom controller of Controller Pair A to port 3 of Fibre Channel switch Y.
 - d. Connect a fiber optic cable from port 2 of the bottom controller of Controller Pair A to port 1 of Fibre Channel switch Y.
 - e. Connect a fiber optic cable from port 1 of the top controller of Controller Pair Y to port 4 of Fibre Channel switch A.
 - f. Connect a fiber optic cable from port 2 of the top controller of Controller Pair Y to port 6 of Fibre Channel switch A.

- g. Connect a fiber optic cable from port 1 of the bottom controller of Controller Pair Y to port 6 of Fibre Channel switch Y.
- h. Connect a fiber optic cable from port 2 of the bottom controller of Controller Pair Y to port 4 of Fibre Channel switch Y.

NOTE: You should see an illuminated green LED on the switch as soon as the cable is inserted at both ends. This verifies that there is a good connection.

- 3. Make the following connections between the hosts and the switches:
 - a. Connect a fiber optic cable from port 0 of Fibre Channel switch A to one adapter in Host A.
 - b. Connect a fiber optic cable from port 0 of Fibre Channel switch Y to the other adapter in Host A.
 - c. Connect a fiber optic cable from port 2 of Fibre Channel switch A to one adapter in Host Y.
 - d. Connect a fiber optic cable from port 2 of Fibre Channel switch Y to the other adapter in Host Y.
 - e. Verify the connections between the hosts and the switches by issuing the following CLI command:

SHOW CONNECTIONS

NOTE: You can also verify the connection by observing the illuminated green LED that flashes on the switch ports.

Disregard the procedure for connecting the external fiber links as described in Chapter 4 in the sections titled “Connect the Target Site to the External Fiber Link” and “Connect the Initiator Site to the External Fiber Link.” These procedures are not needed because the Dual Switch Single Site DRM solution does not accommodate long wave GBICs or other transport modes, since neither the controller nor the HBA support a single-mode long-distance connection.

Single Switch Configuration

This configuration, illustrated in Figure 5–2, is designed for small, single-site entry-level tests and proof of concept demonstrations. This non-disaster-tolerant solution can also be used to produce copies of data needed for data migration or data mining. Currently, the maximum configuration is one 16-port switch, where four ports are used for each fabric at each site. These four ports can support a maximum of two servers and one storage array per simulated site. Switch zoning can be used to simulate the two logical fabrics used by DRM. For more information on zoning, refer to the *Compaq StorageWorks SAN Switch Zoning Reference Guide*.

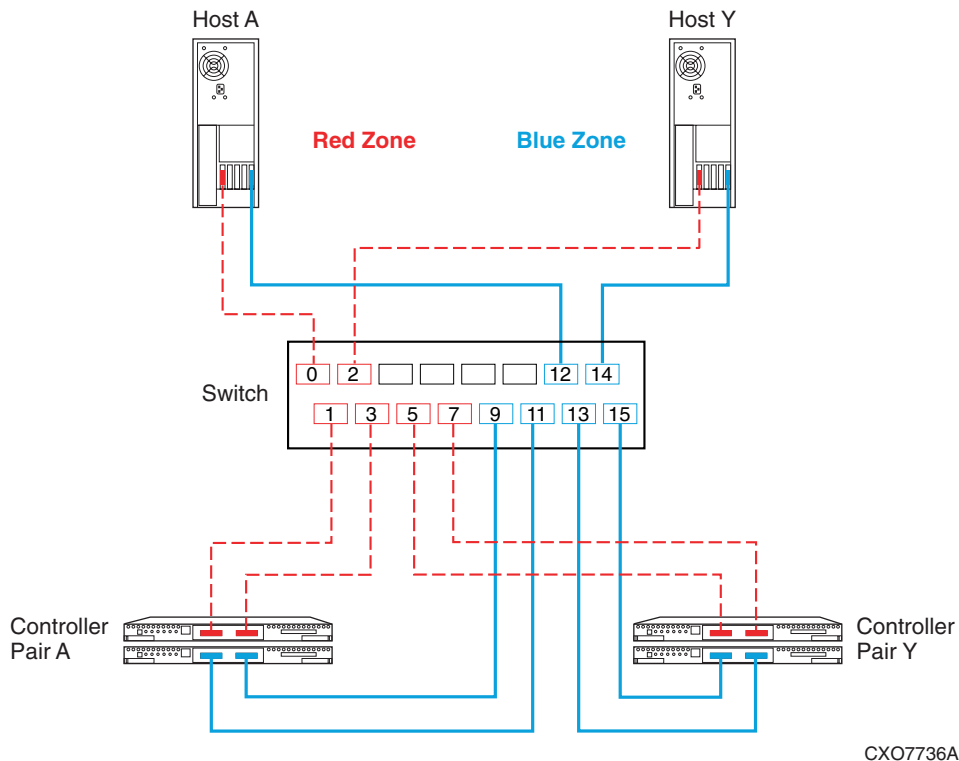

Figure 5–2: Single switch DRM configuration

The maximum 16-port, single switch configuration consists of one pair of arrays and up to four servers.

Setting Up the Single Switch Configuration

Before making any connections with the fiber optic cable, create and enable the zones that simulate two fabrics. As Figure 5–2 shows, the Red Zone uses ports 0 through 7; the Blue Zone uses ports 8 through 15.

NOTE: This configuration uses only multi-mode, 50-micron fiber optic cable and is, therefore, limited to 500 meters for any one connection.

This procedure is a variation of the procedure provided in Chapter 4. To set up the single switch configuration:

1. Install all required GBICs into the Fibre Channel switch with half of the GBICs in each zone.
2. Make the following controller connections:
 - a. Connect a fiber optic cable from port 1 of the top controller of Controller Pair A to port 1 of the Fibre Channel switch.
 - b. Connect a fiber optic cable from port 2 of the top controller of Controller Pair A to port 3 of the Fibre Channel switch.
 - c. Connect a fiber optic cable from port 1 of the bottom controller of Controller Pair A to port 11 of the Fibre Channel switch.
 - d. Connect a fiber optic cable from port 2 of the bottom controller of Controller Pair A to port 9 of the Fibre Channel switch.
 - e. Connect a fiber optic cable from port 1 of the top controller of Controller Pair Y to port 5 of the Fibre Channel switch.
 - f. Connect a fiber optic cable from port 2 of the top controller of Controller Pair Y to port 7 of the Fibre Channel switch.
 - g. Connect a fiber optic cable from port 1 of the bottom controller of Controller Pair Y to port 15 of the Fibre Channel switch.
 - h. Connect a fiber optic cable from port 2 of the bottom controller of Controller Pair Y to port 13 of the Fibre Channel switch.
3. Make the following host connections:
 - a. Connect a fiber optic cable from HBA A of Host A to port 0 of the Fibre Channel switch.

NOTE: You should see an illuminated green LED on the switch as soon as each cable is inserted at both ends. This verifies that there is a good connection.

- b. Connect a fiber optic cable from HBA B of Host A to port 12 of the Fibre Channel switch.
- c. Connect a fiber optic cable from HBA A of Host Y to port 2 of the Fibre Channel switch.
- d. Connect a fiber optic cable from HBA B of Host Y to port 14 of the Fibre Channel switch.

NOTE: Since this configuration uses only one switch, there will not be an ISL. This eliminates the procedure for connecting the external fiber links as described in Chapter 4 in the sections titled “Connect the Target Site to the External Fiber Link” and “Connect the Initiator Site to the External Fiber Link.”

Single Fabric Configuration

This configuration, illustrated in Figure 5–3 with 8-port switches, is designed for small, entry-level tests and proof-of-concept demonstrations where some distance is needed between the switches in the solution. This non-disaster-tolerant solution can also be used to produce copies of data needed for data migration or data mining. Fabric zoning is used to create two logical fabrics out of the one physical fabric. For more information on zoning, refer to the *Compaq SANworks Switch Zoning Reference Guide*.

Because a GBIC is used between switches, and all multi-mode cables are local to a switch, the ISL can be any supported transport, like single-mode fiber, dense wavelength division multiplexing (DWDM), or asynchronous transport mode (ATM). There is no distance limitation between sites.

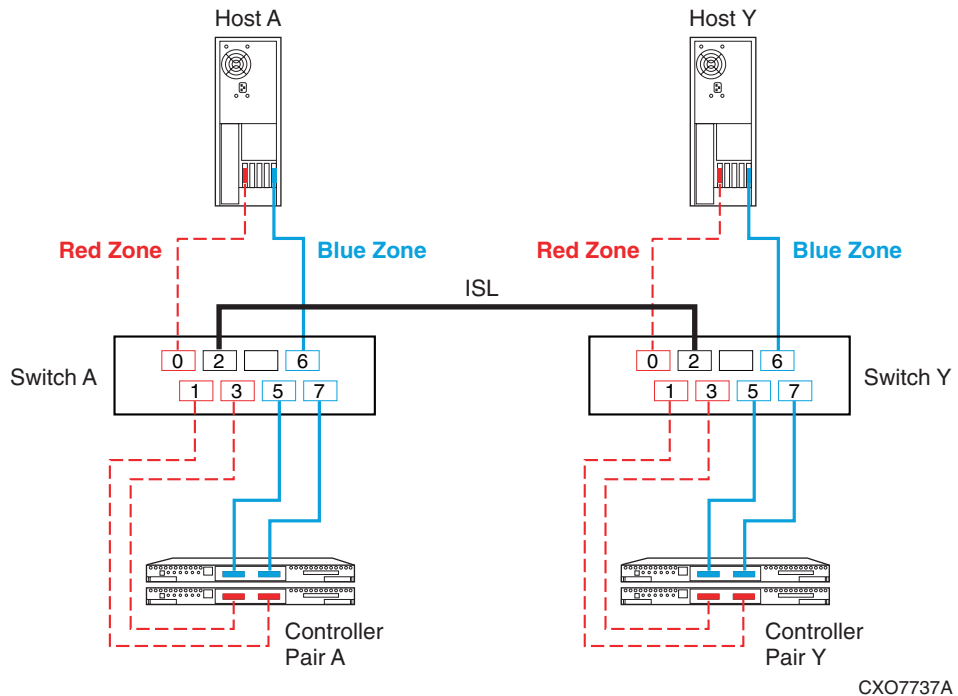

CXO7737A

Figure 5–3: Dual switch with single ISL

NOTE: For 8-EL switches, Compaq recommends that the ISL connection use port 7. Port 7 is the only removable port on the 8-EL switch; the other seven are fixed, short-wave GBICs and are not suitable for ISLs.

The maximum configuration is any of the following:

- 16-port switches
 - one pair of arrays, one or two ISLs, and up to five servers
 - two pairs of arrays, one or two ISLs, and up to three servers
 - three pairs of arrays, one or two ISLs, and one server
- 8-port switches
 - one pair of arrays, one or two ISLs, and one server

The limits on the number of servers are specified in the *Compaq StorageWorks Heterogeneous Open SAN Design Reference Guide*.

The maximum distance between target and initiator is determined by the type of ISL (see Table 5–1).

Setting Up the Single Fabric Configuration

Before making any connections with the fiber optic cable, create and enable the zones that simulate two fabrics. As Figure 5–3 shows, the Red Zone uses ports 0 through 3; the Blue Zone uses ports 4 through 7 of each switch. Refer to the *Compaq StorageWorks SAN Switch Zoning Reference Guide* for instructions to create the zones.

NOTE: This configuration uses multi-mode, 50-micron fiber optic cable on the connections from the controllers to the switches and the connections from the hosts to the switches. The ISL can use either single-mode, 9-micron fiber or multi-mode, 50-micron fiber, or any supported long-distance medium.

This procedure is a variation of the procedure provided in Chapter 4. To set up the single fabric configuration:

1. Install all required GBICs—except those used for the ISL—into the Fibre Channel switches, with half of the GBICs in each zone.
2. Make the following local controller connections:
 - a. Connect a fiber optic cable from port 1 of the top controller of Controller Pair A to port 5 of Fibre Channel switch A.
 - b. Connect a fiber optic cable from port 2 of the top controller of Controller Pair A to port 7 of Fibre Channel switch A.
 - c. Connect a fiber optic cable from port 1 of the bottom controller of Controller Pair A to port 3 of Fibre Channel switch A.
 - d. Connect a fiber optic cable from port 2 of the bottom controller of Controller Pair A to port 1 of Fibre Channel switch A.
3. Make the following remote controller connections:
 - a. Connect a fiber optic cable from port 1 of the top controller of Controller Pair Y to port 5 of Fibre Channel switch Y.
 - b. Connect a fiber optic cable from port 2 of the top controller of Controller Pair Y to port 7 of Fibre Channel switch Y.
 - c. Connect a fiber optic cable from port 1 of the bottom controller of Controller Pair Y to port 3 of Fibre Channel switch Y.

- d. Connect a fiber optic cable from port 2 of the bottom controller of Controller Pair Y to port 1 of Fibre Channel switch Y.

NOTE: You should see an illuminated green LED on the switch as soon as the cable is inserted at both ends. This verifies that there is a good connection.

4. Make the following local host connections:
 - a. Connect a fiber optic cable from HBA A of Host A to port 0 of Fibre Channel switch A.
 - b. Connect a fiber optic cable from HBA B of Host A to port 6 of Fibre Channel switch A.
5. Make the following remote host connections:
 - a. Connect a fiber optic cable from HBA A of Host Y to port 0 of Fibre Channel switch Y.
 - b. Connect a fiber optic cable from HBA B of Host Y to port 6 of Fibre Channel switch Y.
6. Make the following ISL connections:
 - a. Install the appropriate GBIC type (long-wave or short-wave) on each switch. They may be placed anywhere on the switches, regardless of the zoning configuration.
 - b. Connect the fiber optic cable type (multi-mode or single-mode) to the GBICs installed in step 6a.

Configuring the Optional Advanced DRM Solutions

The following sections provide information on different DRM configurations for special circumstances.

Bidirectional DRM Solution

DRM supports active/active bidirectional solutions by using two sets of storage arrays—one set for each direction. This allows both sites to be actively processing data and backing up each other in the event that one of the two sites fails.

As shown in Figure 6–1, there are two servers at each site. These site-specific servers could be clustered during normal operations to provide high-availability applications. When a site failure occurs, the application that was running at the failed site is moved to the backup member of the surviving cluster, and started using the surviving storage and the other half of the surviving cluster.

With additional servers and storage, the bidirectional DRM configuration can scale up to 20 switches in each fabric, supporting, for example, 96 servers and 8 arrays at each site. All intersite technologies, such as DRM over ATM, DRM over direct fiber, DRM over IP, and DRM over WDM, support bidirectional use of DRM.

For more information on intersite technologies, go to:

www.compaq.com/products/storageworks/solutions/bd-drm/index/htm.

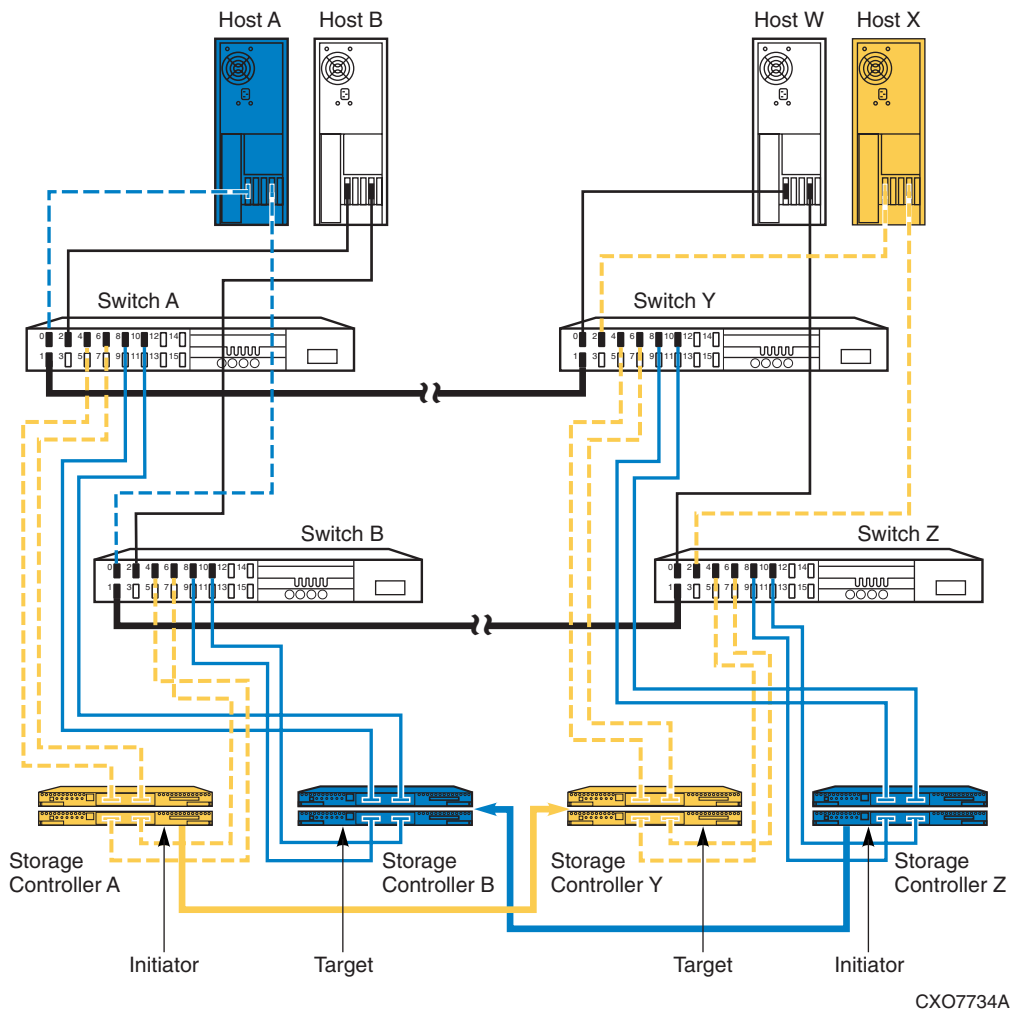

CXO7734A

Figure 6–1: Bidirectional DRM configuration

Stretched Cluster DRM Solution

DRM supports Microsoft Cluster Servers (MSCS) running windows 2000/NT. Stretched cluster means that half of the cluster is at the primary site, and the other half is at the alternate site. If the primary server fails, MSCS fails over the application to the surviving server at the alternate site and resumes operations using the primary site storage.

Applications running in a stretched cluster in failover mode incur a performance penalty because of the time that it takes to read or write data across the intersite link (ISL). The performance penalty is directly proportional to the distance between the two sites—the greater the distance, the greater the penalty. However, at separation distances of up to 100 km, you should see no additional performance degradation.

For more information on stretched cluster support, go to the Compaq ProLiant HA/F500 website at:

<http://www.compaq.com/solutions/enterprise/ha-f500.html>

Troubleshooting

This chapter shows you how to interpret information from the HSG80 controllers, the SAN switches, and the operating system to aid in troubleshooting.

The user of these troubleshooting procedures must be familiar with Data Replication Manager (DRM) procedures and Command Line Interface (CLI) commands and must be proficient with the HSG80.

Refer to the *Compaq SANworks Data Replication Manager by Compaq HSG80 Version 8.6-4P Failover/Failback Procedures Guide* for additional and more detailed troubleshooting procedures. Refer to the *Compaq StorageWorks HSG80 Array Controller ACS Version 8.6 Maintenance and Service Guide* for HSG80 information.

The goal of these troubleshooting procedures is to determine the cabling or connections between controllers, switches, Host Bus Adapters (HBAs), and servers across target and initiator sites. Once the actual cabling is known, it may be compared with the intended cabling to account for sources of error.

To determine the cabling, we will first obtain information from the controller pairs, then from the switches, and finally from the operating system.

This chapter covers the following topics:

- “Preliminary Checks” on page 7–2
- “Information from the Controllers” on page 7–3
 - “Step 1: Issue a SHOW THIS Command” on page 7–3
 - “Step 2: Issue a SHOW OTHER Command” on page 7–6
 - “Step 3: Issue a SHOW CONNECTIONS Command” on page 7–8
- “Information from the Switches” on page 7–11
 - “Step 4: Issue switchShow Command from the First Switch” on page 7–12
 - “Step 5: Issue switchShow Command from the Second Switch” on page 7–14
 - “Step 6: Issue switchShow Command from the Third Switch” on page 7–16
 - “Step 7: Issue switchShow Command from the Fourth Switch” on page 7–18

- “Information from the Operating Systems” on page 7–20
 - “Step 8: Associating HBAs with Servers” on page 7–21
- “Other Troubleshooting Considerations” on page 7–25
 - “Show Commands” on page 7–25
 - “Zoning” on page 7–27
 - “Secure Path” on page 7–27
- “Controller Replacement in a DRM Configuration” on page 7–27
 - “Procedure When Replacement Controller Status is Unknown” on page 7–27
 - “Procedure When Non-DRM Controller Subsystem is Not Available” on page 7–28

Preliminary Checks

Before you begin the troubleshooting procedures, verify that the hardware components have power and are functioning properly. For help getting a terminal connection to the controller, refer to the *Compaq StorageWorks HSG80 ACS Solution Software Version 8.6 Installation and Configuration Guide* for your operating system. See the *Compaq StorageWorks HSG80 Array Controller ACS Version 8.6 Troubleshooting Reference Guide* for a checklist of common problems.

Once you have determined that the hardware is working properly, issue SHOW commands to verify that your storage sets, units, and association sets are configured correctly. Refer to the *Compaq StorageWorks HSG80 ACS Solution Software Version 8.6 Installation and Configuration Guide* (for your operating system), and the *Compaq StorageWorks HSG80 Array Controller ACS Version 8.6 Troubleshooting Reference Guide* for more information. See the *SANworks Data Replication Manager by Compaq HSG80 Version 8.6-4P Failover/Failback Procedures Guide* for information specific to DRM failures during failover and failback.

Information from the Controllers

Follow the steps in this section to acquire cabling information from the controllers.

Step 1: Issue a SHOW THIS Command

Telnet into the initiator-controller pair and issue a SHOW THIS CLI command. Table 7–1 shows typical output from a SHOW THIS command and highlights in boldface the information relevant to troubleshooting.

Table 7-1: SHOW THIS Command Analysis

SHOW THIS command output	What to look for	Related Commands
<p>Controller: HSG80 ZG94115534 Software V86P-4, NODE_ID = 5000-1FE1-0007-9DD0 ALLOCATION_CLASS = 0 SCSI_VERSION = SCSI-3</p> <p>Configured for MULTIBUS_FAILOVER with ZG94416756</p> <p>Device Port SCSI address 7 Time: 02-APR-2001 16:06:21</p> <p>Command Console LUN is lun 0 Host PORT_1: Reported PORT_ID = 5000-1FE1-0007-9DD3 PORT_1_TOPOLOGY = FABRIC (fabric up) Address = 210413</p> <p>Host PORT_2 Reported PORT_ID = 5000-1FE1-0007-9DD4 PORT_2_TOPOLOGY = FABRIC (fabric up)</p>	<p>Make sure serial number is unique. Check the ACS version</p> <p>Make sure the NODE_ID (WWID)</p> <p>SCSI-3 only for Open VMS; SCSI-2 or SCSI-3 for Tru64 UNIX, NetWare, Windows 2000/NT; SCSI-2 only for AIX and Solaris.</p> <p>Verify multibus failover mode. Verify that the serial number is unique. Set the time before running</p> <p>SCSI-3 set this automatically to 0.</p> <p>Top controller port 1 address. If offline, there is no connection to Switch domain 1 port 4 is connected to port 1. Note that the second number in the switch port</p> <p>Top controller port 2 address. If offline, there is no connection to</p>	<p>Your WWIDs will be different from those shown in this example.</p> <p>set this scsi_version=scsi-3</p> <p>set multibus_failover</p> <p>set this time = 02-APR-2001:16:06:00</p> <p>set this</p> <p>set this</p>

Table 7-1: SHOW THIS Command Analysis (Continued)

SHOW THIS command output	What to look for	Related Commands
<p>Address = 210513</p> <p>REMOTE_COPY = BUILDNGA</p> <p>Cache: 256 megabyte write cache, version 0012</p> <p>Cache is GOOD*****</p> <p>No unflushed data in cache</p> <p>CACHE_FLUSH_TIMER = DEFAULT (10</p> <p>Mirrored Cache: 256 megabyte write cache, version 0012</p> <p>Cache is GOOD</p> <p>No unflushed data in cache</p> <p>Battery: NOUPS FULLY CHARGED</p>	<p>Switch domain 1 port 5 is</p> <p>Alias for this pair of controllers.</p> <p>256 MB (512 MB before mirroring) is minimum required for DRM.</p> <p>If cache is invalid, it needs to be</p> <p>If the battery is insufficiently charged, wait until it is fully</p>	<p>set this remote_copy=</p> <p>set this mirrored_cache</p> <p>clear this_invalid cache</p> <p>destroy_unflushed data</p> <p>run FRUTIL</p>

The WWID (NODE_ID) in Table 7–1 is 5000-1FE1-0007-9DD0; the four ports on the controller pair are always arranged as shown in Figure 7–1. The -9DD0 WWID for the controller pair dictates the -9DD1 through -9DD4 WWIDs for the ports.

NOTE: The WWID numbering scheme shown in Figure 7–1 is true only when the controllers are in multibus failover mode; it is not true for transparent mode.

-9DD0

Port 1 Top controller -9DD3	Port 2 Top controller -9DD4
Port 1 Bottom controller -9DD1	Port 2 Bottom controller -9DD2

CXO7651A

Figure 7–1: Controller pair World Wide IDs

Step 2: Issue a SHOW OTHER Command

Check for consistency in the other controller by issuing a SHOW OTHER command. Table 7–2 shows a typical output from the SHOW OTHER command and highlights the information relevant to troubleshooting.

Table 7–2: SHOW OTHER Command Analysis

SHOW OTHER Command Output	What to look for
Controller: HSG80 ZG94416756 Software V86P-4 , Hardware E10 NODE_ID = 5000-1FE1-0007-9DD0 ALLOCATION_CLASS = 0 SCSI_VERSION = SCSI-3 Configured for MULTIBUS_FAILOVER with ZG94115534 In a dual-redundant configuration Device Port SCSI address 6 Time: 02-APR-2001 16:06:21	Verify ACS code version is same on both controllers. Allocation class may be set by OpenVMS. SCSI version may also be SCSI-2. Verify that controller is in multibus failover mode.

Table 7-2: SHOW OTHER Command Analysis (Continued)

SHOW OTHER Command Output	What to look for
<p>Command Console LUN is lun 0 (NOIDENTIFIER) Host PORT_1: Reported PORT_ID = 5000-1FE1-0007-9DD1</p>	
<p>PORT_1_TOPOLOGY = FABRIC (fabric up) Address = 200413 Host PORT_2 Reported PORT_ID = 5000-1FE1-0007-9DD2 PORT_2_TOPOLOGY = FABRIC (fabric up) Address = 200613 REMOTE_COPY = BUILDNGA Cache: 256 megabyte write cache, version 0012 Cache is GOOD No unflushed data in cache CACHE_FLUSH_TIMER = DEFAULT (10 seconds) Mirrored Cache: 256 megabyte write cache, version 0012 Cache is GOOD No unflushed data in cache Battery: NOUPS FULLY CHARGED Expires: WARNING: UNKNOWN EXPIRATION DATE! WARNING: AN UNKNOWN NUMBER OF DEEP DISCHARGES HAVE OCCURRED!</p>	<p>Switch domain 0, port 4.</p> <p>Switch domain 0, port 6.</p> <p>If the battery is insufficiently charged, wait until it is fully charged or, if necessary, replace the battery. Run FRUTIL to set the expiration date.</p>

From the SHOW THIS and SHOW OTHER command results, we know that there are two switches: domain 0 (from the port addresses highlighted in Table 7–2) and domain 1 (from the port addresses highlighted in Table 7–1). We also know that the storage array is connected as follows:

- Switch domain 1, ports 4 and 5 are cabled to the top controller (port addresses 210413 and 210513 in Table 7–1).
- Switch domain 0, ports 4 and 6 are cabled to the bottom controller (port addresses 200413 and 200613 in Table 7–2).

Step 3: Issue a SHOW CONNECTIONS Command

Issue a SHOW CONNECTIONS command to show which connections the controller can see. Table 7–3 shows a typical output from the SHOW CONNECTIONS command and highlights the information relevant to troubleshooting.

Table 7-3: SHOW CONNECTIONS Command Analysis

SHOW CONNECTIONS Command Output							Comments
Connection	Operating system	Controller	Port	Address	Status	Unit	
Name Offset							Choose a meaningful name; example: rename !newcon66 hostA_1. Set to proper operating system type; example: set !newcon66 operating_system=SUN.
!NEWCON66	WINNT	THIS	1	200013	OL	this	
0							
	HOST_ID=1000-0000-C920-C9E1						
	ADAPTER_ID=1000-0000-C920-C9E1						
!NEWCON67	WINNT	OTHER	1	200013	OL	other	
0							
	HOST_ID=1000-0000-C920-C9F0						
	ADAPTER_ID=1000-0000-C920-C9F0						
!NEWCON68	WINNT	THIS	1	200013	OL	this	Online to this controller.
0							
	HOST_ID=1000-0000-C921-F21A						
	ADAPTER_ID=1000-0000-C921-F21A						
!NEWCON69	WINNT	OTHER	1	200013	OL	other	
0							
	HOST_ID=1000-0000-C921-F251						
	ADAPTER_ID=1000-0000-C921-F251						WWID of HBA.

SHOW CONNECTIONS Command Output	Comments
<pre> BUILDNGBA PPRC_TARGET THIS 2 200513 OL this 0 HOST_ID=5000-1FE1-0007-9DE0 ADAPTER_ID=5000-1FE1-0007-9DE4 </pre>	<p>BUILDNGBA and BUILDNGBB must be online to the initiator for remote copy sets to work. Example: add remote rcs199 d199 buildingb\vd199.</p>
<pre> BUILDNGBB PPRC_TARGET OTHER 2 210E13 OL other 0 HOST_ID=5000-1FE1-0007-9DE0 ADAPTER_ID=5000-1FE1-0007-9DE2 </pre>	
<pre> BUILDNGBC PPRC_INITIATOR THIS 2 200513 offline 0 HOST_ID=5000-1FE1-0007-9DE0 ADAPTER_ID=5000-1FE1-0007-9DE4 </pre>	
<pre> BUILDNGBD PPRC_INITIATOR OTHER 2 200513 offline 0 HOST_ID=5000-1FE1-0007-9DE0 ADAPTER_ID=5000-1FE1-0007-9DE2 </pre>	

Notice the port usage for each connection. In multiple-bus failover mode with remote copy enabled (that is, a DRM configuration), port 1 on both controllers are connected only to HBAs. Port 2 on both controllers are connected only to other controllers. Ports 1 and 2 are reserved ports for DRM configurations.

Make a note of each adapter's WWID. The controller adds a new connection entry when any of the following keys change:

- Host WWID
- Adapter WWID
- Controller host port number
- Controller WWID

There will be four connections through port 2, labeled A, B, C, and D. In the example in Table 7–3, they are BUILDNGBA, BUILDNGBB, BUILDNGBC, and BUILDNGBD. In most cases, only two of these connections are online: A and B at the initiator site; C and D at the target site. A and B are used to write to the target site while C and D receive write requests from the initiator site. Thus, initiator A writes to target C and initiator B writes to target D.

We now know that we are online to four host bus adapters whose adapter IDs end in -C9E1, -C9F0, -F21A, and -F251. We also know that unit address 200013 is switch domain 0, port 0. There appears to be two different adapters cabled to the same switch: -F251 and -C9E1, both to port 0. That cannot be the case, because there cannot be two switch domain 0s on the same fabric. We actually have two switch 0s and two switch 1s. The best way to confirm this is to telnet to the switches and issue the switchShow command.

Information from the Switches

For detailed information on accessing and using switches, refer to the *Compaq StorageWorks Fibre Channel SAN Switch Management Guide*.

Telnet into a switch and check its firmware version by issuing the version command at the switch prompt. The command and its output will be similar to that shown in Table 7–4.

Table 7–4: Switch Version Command

```
sw11:admin> version
Kernal: 5.3.1
Fabric OS: v2.1.7
Made on: Wed May 24 14:47:36 PDT 2000
Flash: Wed May 24 14:48:05 PDT 2000
BootProm Thu Jun 17 15:20:39 PDT 1999
```



CAUTION: Switches with incompatible firmware will cause the fabric to segment. Switches in the same fabric with the same domain number will also cause the fabric to segment. to change the domain number, issue the CONFIGURE SWITCH command.

Step 4: Issue switchShow Command from the First Switch

Issue a SWITCHSHOW command at the switch prompt to see the port connections:

```
sw11:admin> switchShow
```

Table 7–5 shows typical output from the SWITCHSHOW command and highlights the information relevant to troubleshooting.

Table 7–5: First switchShow Command Output

Command Output	Comments
switchName: sw11	Name of the switch.
switchType: 2.4	
switchState: online	
switchRole: Principal	
switchDomain: 1	Domain.
switchId: ffc41	
switchWwn: 10:00:00:60:69:10:47:69	WWID.
port 0: sw Online F-Port 10:00:00:00:c9:20:c9:f0	WWIDs that start with 10:00 are HBAs.
port 1: -- No_Module	
port 2: -- No_Module	

Table 7–5: First switchShow Command Output (Continued)

Command Output	Comments
port 3: -- No_Module port 4: -- No_Light port 5: -- No_Module port 6: -- No_Module port 7: -- No_Module port 8: -- No_Module port 9: -- No_Module port 10: -- No_Module port 11: -- No_Module port 12: -- No_Module	Check for a bad GBIC or cable.
port 13: sw Online F-Port 50:00:1f:00:07:20:9d:e1	Cabled to port 1 of the bottom controller.
port 14: sw Online F-Port 50:00:1f:00:07:20:9d:e2	Cabled to port 2 of the bottom controller.
port 15: sw Online E-Port 10:00:00:60:69:00:54:65 “sw12” (downstream)	ISL - always on E-Port.

NOTE: WWIDs that start with 10:00 or 20:00 are HBAs. WWIDs that start with 50:00 are controllers or controller ports. WWIDs that start with 60:00 are LUNs.

From the SWITCHSHOW command output, we know that there is an ISL from the switch named sw11 to a switch named sw12 (port 15). Figure 7–2 is a picture of the cabling information we have gathered so far. It is drawn from Table 7–5, which shows that:

- Port 0 of sw11 (where we issued the SWITCHSHOW command) is cabled to the HBA whose WWID ends in -C9F0.
- Port 13 of sw11 is cabled to port 1 of the bottom controller.
- Port 14 of sw11 is cabled to port 2 of the bottom controller.
- Port 15 of sw11 is cabled via an ISL to sw12.

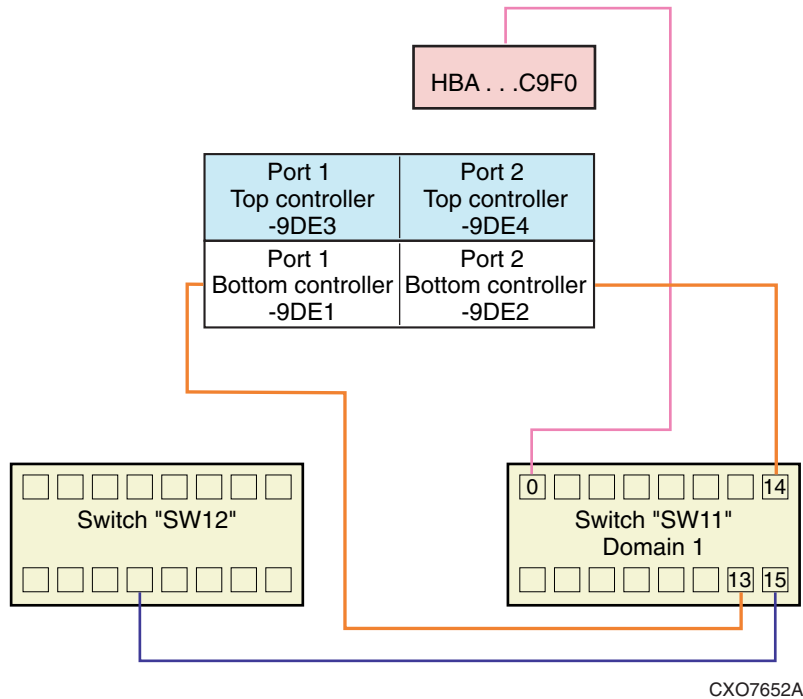

Figure 7–2: First cabling diagram

Step 5: Issue switchShow Command from the Second Switch

Telnet into another switch and issue a SWITCHSHOW command at the switch prompt to acquire the port connection information:

```
sw13:admin> switchShow
```

Table 7–6 shows typical output from the SWITCHSHOW command.

Table 7–6: Second switchShow Command Output

switchName: sw13
switchType: 2.4
switchState: <u>o</u> nline
switchRole: Subordinate
switchDomain: 1

Table 7–6: Second switchShow Command Output (Continued)

```
switchId: ffc41
switchWwn: 10:00:00:60:69:00:51:5a
port 0: sw Online   F-Port 10:00:00:00:c9:21:f2:1a
port 1: -- No_Module
port 2: -- No_Module
port 3: -- No_Module
port 4: -- sw Online   F-Port 50:00:1f:e1:00:07:9d:d3
port 5: -- sw Online   F-Port 50:00:1f:e1:00:07:9d:d4
port 6: -- sw Online   E-Port 10:00:00:60:69:00:57:0a “sw14” (upstream)
port 7: -- No_Module
port 8: -- No_Module
port 9: -- No_Module
port 10: -- No_Module
port 11: -- No_Module
port 12: -- No_Module
port 13: -- No_Module
port 14: -- No_Module
port 15: -- No_Module
value = 16 = 0x10
```

NOTE: This switch is named sw13, which also has a domain of 1. We recommend that each switch have a unique domain within the fabric. We recommend unique names even across fabrics.

Figure 7–3 is a picture of the cabling information we have gathered so far. The cabling information added to Figure 7–3 is drawn from Table 7–6, which shows that:

- Port 0 of sw13 (where we issued the SWITCHSHOW command) is cabled to the HBA whose WWID ends in -F21A.
- Port 4 of sw13 is cabled to port 1 of the top controller at the same site.
- Port 5 of sw13 is cabled to port 2 of the top controller at the same site.
- Port 6 of sw13 is cabled via an ISL to sw14.

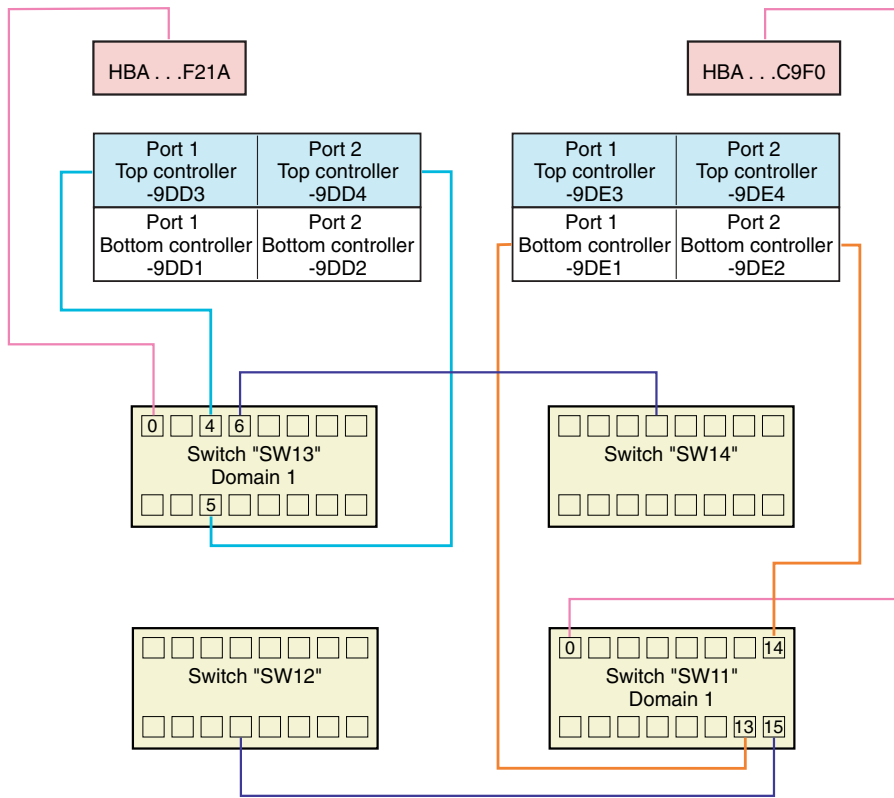

CXO7653A

Figure 7-3: Second cabling diagram

Step 6: Issue switchShow Command from the Third Switch

Telnet into the third switch and issue a SWITCHSHOW command at the switch prompt to acquire the port connection information:

```
sw12:admin> switchShow
```

Table 7-7 shows typical output from the SWITCHSHOW command.

Table 7–7: Third switchShow Command Output

```

switchName: sw12
switchType: 2.4
switchState: Online
switchRole: Principal
switchDomain: 0
switchId: ffc40
switchWwn: 10:00:00:60:69:00:54:65
port 0: sw Online   F-Port 10:00:00:00:c9:21:f2:51
port 1: -- No_Module
port 2: -- No_Module
port 3: -- No_Module
port 4: -- sw Online   F-Port 50:00:1f:e1:00:07:9d:d1
port 5: -- No_Module
port 6: -- sw Online   F-Port 50:00:1f:e1:00:07:9d:d2
port 7: -- sw Online   E-Port 10:00:00:60:69:10:47:69 "sw11" (downstream)
port 8: -- No_Card
port 9: -- No_Card
port 10: -- No_Card
port 11: -- No_Card
port 12: -- No_Card
port 13: -- No_Card
port 14: -- No_Card
port 15: -- No_Card
value = 16 = 0x10

```

Figure 7–4 is the cabling diagram with the port connections from the sw12 switch added. The additional cabling is drawn from information highlighted in Table 7–7, which shows that:

- Port 0 of sw12 is cabled to the HBA whose WWID ends in -F251.
- Port 4 of sw12 is cabled to port 1 of the bottom controller at the same site.

- Port 6 of sw12 is cabled to port 2 of the bottom controller at the same site.
- Port 7 of sw12 is cabled via an ISL to sw11 (compare with port 15 of sw11 in Table 7-5).

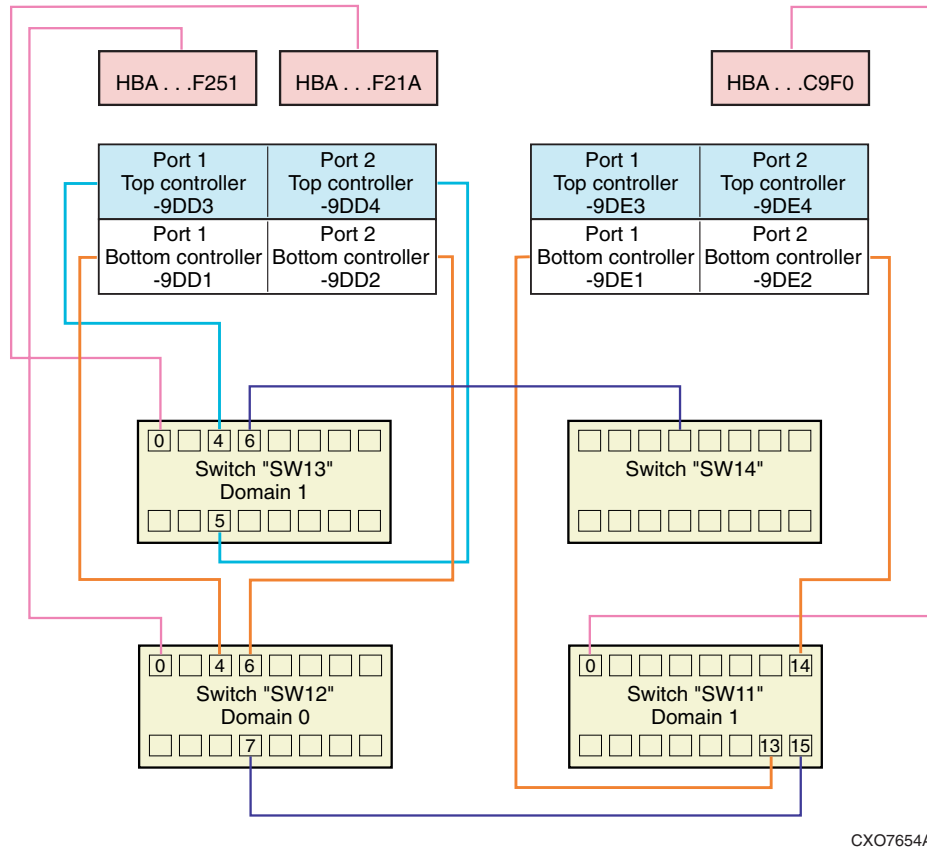

Figure 7-4: Third cabling diagram

Step 7: Issue switchShow Command from the Fourth Switch

Telnet into the fourth and final switch and issue a SWITCHSHOW command at the switch prompt to acquire the port connection information:

```
sw14:admin> switchShow
```

Table 7-8 shows typical output from the SWITCHSHOW command.

Table 7–8: Fourth switchShow Command Output

```
switchName: sw14
switchType: 2.4
switchState: Online
switchRole: Principal
switchDomain: 0
switchId: ffc40
switchWwn: 10:00:00:60:69:00:57:0a
port 0: sw Online   F-Port 10:00:00:00:c9:20:c9:e1
port 1: -- No_Module
port 2: -- No_Module
port 3: -- No_Module
port 4: -- sw Online   F-Port 50:00:1f:e1:00:07:9d:e3
port 5: -- sw Online   F-Port 50:00:1f:e1:00:07:9d:e4
port 6: -- sw Online   E-Port 10:00:00:60:69:00:51:5a "sw13" (downstream)
port 7: -- No_Module
port 8: -- No_Module
port 9: -- No_Module
port 10: -- No_Module
port 11: -- No_Module
port 12: -- No_Module
port 13: -- No_Module
port 14: -- No_Module
port 15: -- No_Module
```

Figure 7–5 is the cabling diagram with the port connections from the sw14 switch added. The additional cabling is drawn from information highlighted in Table 7–8, which shows the cabling for all four switches:

- Port 0 of sw14 is cabled to the HBA whose WWID ends in -C9E1.
- Port 4 of sw14 is cabled to port 1 of the top controller at the same site.
- Port 5 of sw14 is cabled to port 2 of the top controller at the same site.

- Port 6 of sw14 is cabled via ISL to port 6 of sw13 (compare with port 6 of sw13 in Table 7–6).

Information from the Operating Systems

Figure 7–5 shows both fabrics (two sets of switches that communicate), but we do not yet know which HBAs go to which servers.

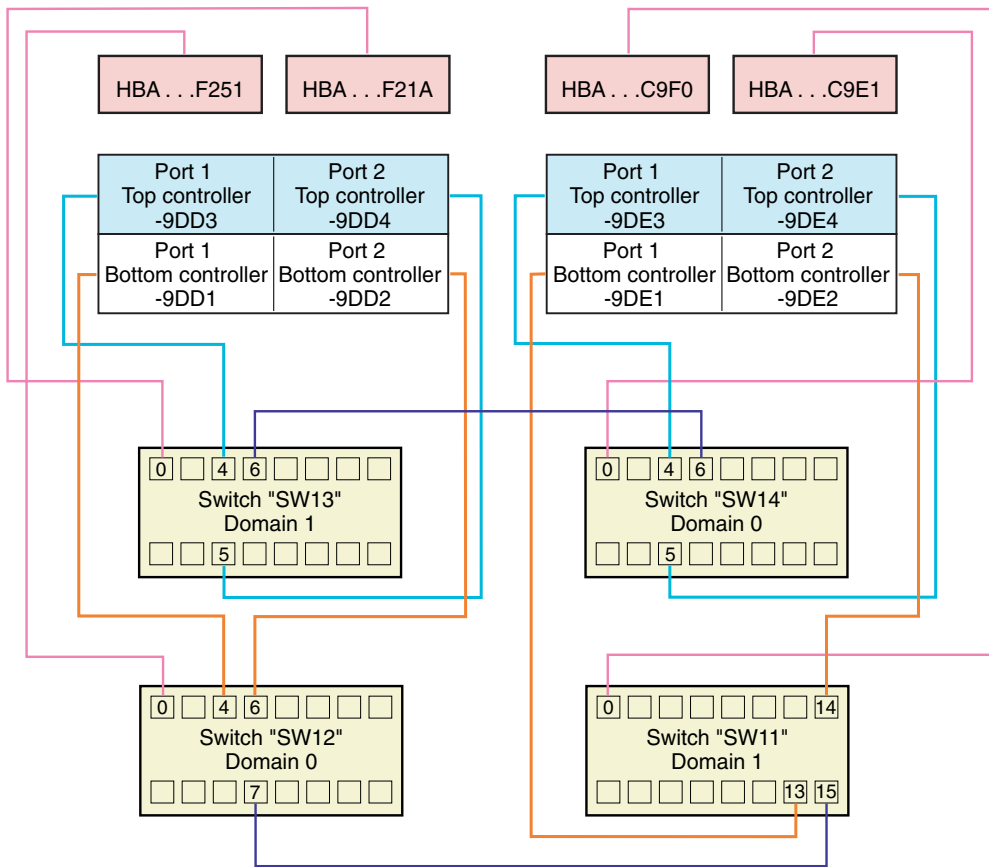

CXO7655A

Figure 7–5: Fourth cabling diagram

Step 8: Associating HBAs with Servers

Our ability to associate HBAs with servers (without removing the adapter from the server and reading the label) depends on operating system and platform type. The following sections provide procedures for determining the server WWIDs for each operating system.

Compaq OpenVMS

Shut down the system and use the console WWID manager to issue the following commands:

```
>>> Set mode diag
POO>>> wwidmgr -adapter kgpsa0
POO>>> wwidmgr -adapter kgpsa1
```

Repeat for each server.

Compaq Tru64 UNIX

Issue the following command at the system prompt:

```
#uerf -R -r 300lmore
```

This shows what the system found during boot; it includes the WWID of the HBAs and the revision level of the emx driver.

Repeat for each server.

HP-UX

Issue the following command to get a display of HBAs:

```
ioscan -fn
```

The output from this command will be similar to:

```
Class I  H/W Path Driver S/W State H/W Type  Description
fc    0  0/2/0/0  td    CLAIMED  INTERFACE  HP Tachyon TL/TS Fibre Channel Mass
Storage Adapter
```

Issue the following command to get a display of an HBA's WWN:

```
/opt/fcms/bin/fcmsutil /dev/tcl , where I is the instance number.
```

Using the I value obtained from the ioscan, issue the commands:

```
/opt/fcms/bin/fcmsutil /dev/td0
```

```
N_Port Port World Wide Name = 0x50060b00000a354e
```

Repeat for each HBA instance.

IBM AIX

Issue the following command from a command console prompt to obtain WWIDs for all Cambex adapters:

```
lsdev -Cc adapter
```

This command produces output similar to the following:

```
scsix Available 20-58 Cambex Fibre Channel I/O Controller
```

where *x* is a numeric value assigned by the operating system.

Using the *x* value obtained from the previous command, issue the command:

```
lscfg -vl scsix
```

where *x* is a numeric value assigned by the operating system. The value following Network Address is the WWID.

Now that we can determine which HBAs are in each host, there is enough information to complete the configuration diagram. Figure 7-6 shows the complete configuration.

Microsoft Windows NT and Windows 2000

Execute the following procedure:

1. Shut down the server.
2. Boot the server from a bootable DOS diskette.
3. Insert the KGPSA diskette shipped with the adapter for Intel part AK-RF2LC-CA.
4. Issue the following DOS commands:

```
A:\cd l386  
A:\1p6dutil
```
5. Select option 6 (Show Host adapters info).
6. Select Host Adapter (1 or 2).
7. Write down its WWID.

8. Exit the menu by selecting 0.
9. Exit the program by selecting menu item 7.

Repeat for each server.

Novell NetWare

To obtain WWIDs for NetWare systems, you must read them directly from the adapters or from your notes taken during installation.

Sun Solaris

Issue the following command at the system prompt:

```
#more /var/adm/messages
```

Look for the driver name like fcaw. It lists the adapter WWIDs, which start with 10:00 or 20:00.

Repeat for each server.

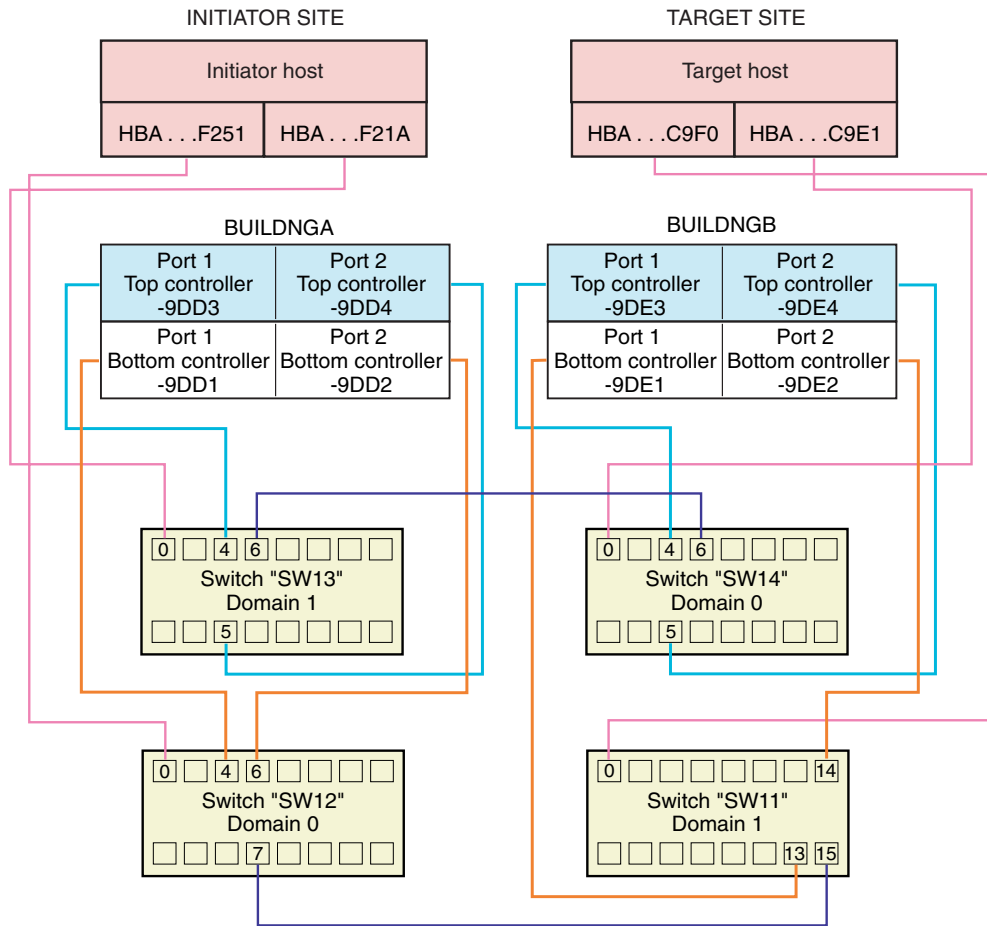

CX07656A

Figure 7-6: Final configuration

Verify that the configuration in Figure 7-6 is the design that was intended and that there are two fabrics. Verify that it is configured for no single point of failure.

Other Troubleshooting Considerations

SHOW commands, zoning, and Secure Path may also assist in troubleshooting.

Show Commands

Information useful for troubleshooting can be acquired by issuing various SHOW commands. See Appendix A for a list of SHOW commands used in troubleshooting. Two particularly useful commands are SHOW UNITS FULL and SHOW REMOTE FULL.

SHOW UNITS FULL

At the initiator controller, issue the SHOW UNITS FULL command. Table 7–9 shows a typical output.

Table 7–9: SHOW UNITS FULL Command Output

LUN	Uses	Used by	

D1	DISK10000		
LUN ID:	6000-1FE1-0008-0A50-0009-0510-3520-0001		
NOIDENTIFIER			
Switches:			
RUN	NOWRITE_PROTECT	READ_CACHE	
READAHEAD_CACHE	WRITEBACK_CACHE		
MAX_READ_CACHED_TRANSFER_SIZE	= 32		
MAX_WRITE_CACHED_TRANSFER_SIZE	= 32		
Access:			
	HOSTA_1, HOSTA_2, BUILDNGBA, BUILDNGBB,		Check for proper access (that is, hosts and target controllers).
	BUILDNGBC, BUILDNGBD		
State:			
	ONLINE to this controller		Verify that it is online.

Table 7–9: SHOW UNITS FULL Command Output (Continued)

<p>Not reserved</p> <p>NOPREFERRED_PATH</p> <p>Size: 17769177 blocks</p> <p>Geometry (C/H/S): (5258 / 20 / 169)</p>	<p>If Tru64, watch for persistent reserve.</p>
--	--

SHOW REMOTE FULL

At the initiator controller, issue the SHOW REMOTE FULL command. Table 7–10 shows a typical output.

Table 7–10: SHOW REMOTE FULL Command Output

Name	Uses	Used by	
<p>-----</p> <p>RCS1 remote copy D1 A1</p> <p>Reported LUN ID: 6000-1FE1-0009-1D70-0009-9421-3547-0176</p> <p>Switches:</p> <p>OPERATION_MODE = SYNCHRONOUS</p> <p>ERROR_MODE = FAILSAFE</p> <p>FAILOVER_MODE = MANUAL</p> <p>OUTSTANDING_IOS = 20</p> <p>Initiator (BUILDNGA\D1) state:</p> <p>ONLINE to this controller</p> <p>Not reserved</p> <p>Target state:</p> <p>BUILDNGB\D1 is NORMAL</p>			<p>If in failsafe mode, units can become failsafe locked.</p> <p>Verify that the remote copy set has a target.</p>

Zoning

Improper zoning can prevent the proper access to controllers and hosts. Refer to the *Compaq SANworks Switch Zoning Reference Guide* for information on zoning and to Chapter 6, “Configuring the Optional Advanced DRM Solutions,” in this guide for information on zoning for a DRM configuration.

Secure Path

If the same unit shows up twice in AIX, Solaris, NetWare, Windows NT, or Windows 2000, or does not show up at all, then Secure Path is not working properly. Refer to the *Compaq SANworks Secure Path Installation and Reference Guide* for your operating system.

NOTE: This does not apply to OpenVMS or Tru64 UNIX, since they both have built-in multi-bus driver support.

Controller Replacement in a DRM Configuration

When a failed controller needs to be replaced, follow the supported procedure in the *Compaq StorageWorks HSG80 Array Controller ACS Version 8.6 Maintenance and Service Guide* using FRUTIL. It is important to note that this procedure specifies a new controller from the factory or a newly initialized (purged of an old configuration) controller. Using a factory-fresh or newly initialized (configuration-free) controller is particularly important when your configuration is set up for DRM. Not using a newly initialized controller causes cache corruption on the replacement controller mirrored cache.

Procedure When Replacement Controller Status is Unknown

If you are not certain whether or not your replacement controller has a configuration, you may initialize it on a non-DRM-configured controller subsystem using the following procedure:

1. Using FRUTIL, remove a controller from the non-DRM-configured subsystem.
2. Using FRUTIL, insert your replacement controller in the non-DRM-configured subsystem, *leaving the programming card out* (the controller will not start).
3. Press and hold the replacement controller reset button.
4. Insert the programming card.
5. Press and hold the port 5 button until the reset button LED is blinking.

6. Release the replacement controller reset button.

Your replacement controller is now initialized with no configuration. Use FRUTIL to remove the initialized controller and reinstall the original controller into the non-DRM subsystem.

Procedure When Non-DRM Controller Subsystem is Not Available

If you are not certain of the status of your replacement controller and a non-DRM controller subsystem is not available, use the following procedure:

1. Stop all host I/O to the DRM controller subsystem.
2. Run FRUTIL to remove the failed controller.
3. Shut down the surviving controller by issuing the following command:
SHUTDOWN THIS_CONTROLLER
4. Insert the replacement controller with the programming card removed.
5. Press and hold the reset button on both controllers and insert the programming card in the replacement controller.
6. Press and hold the port 5 button on the replacement controller.
7. Release the reset button on both controllers.
8. Hold the port 5 button until the reset button LED is blinking on the replacement controller.

The controller halts with OCP code 38.

9. Restart the replacement controller, by pressing the reset button on the replacement controller.

The controller is now initialized with no configuration.

10. Enter the following CLI command on the surviving controller:

```
SET MULTIBUS_FAILOVER COPY = THIS_CONTROLLER
```

Zoning in the Storage Area Network

This chapter describes DRM concepts and variations for alternative DRM configurations. These descriptions include cascaded switches, multiple intersite links (ISLs), dual switch/single site DRM solutions, and switch zoning.

The topics in this chapter are:

- “Switch Zoning” on page 8–1
- “Planning Considerations for Homogeneous and Heterogeneous Configurations That Require Zoning” on page 8–2
- “Zoning Hosts and HSG80 Subsystems Between Sites” on page 8–2
 - “More than 96 Host Connections” on page 8–2
- “Zoning A DRM Configuration” on page 8–3
 - “DRM Homogeneous Configuration” on page 8–3
 - “DRM Heterogeneous Configuration” on page 8–17
- “Zoning to Allow Host Access Between Sites” on page 8–30

Switch Zoning

The Fibre Channel switch zoning feature provides a means to control storage area network (SAN) access at the node port level. Zoning can be used to separate one physical fabric into many virtual fabrics consisting of selected server and storage ports. This capability allows you to:

- Set up barriers between different operating environments.
- Deploy logical fabric subsets by creating defined user groups.
- Create separate test and maintenance areas within the fabric.
- Flexibly manage a SAN while meeting the different objectives of closed user groups.

You can display a list of switch commands by typing `help` and `zoneHelp` at the switch prompt.

For more information on when to use switch zoning, refer to the *Heterogeneous Open SAN Design Guide*. For additional information on switch zoning, refer to the *Compaq StorageWorks SAN Switch Zoning Reference Guide* and the *Compaq StorageWorks Fibre Channel SAN Switch Management Guide*.

Planning Considerations for Homogeneous and Heterogeneous Configurations That Require Zoning

Planning is an essential part of the zoning process. The following sections provide guidelines and instructions for zoning your DRM solution.

More than 96 Host Connections

A host connection is a data path from one host bus adapter (HBA) to one active controller host port, even if the host connection uses storage units on that storage system.

The HSG80 controller has a limit of 96 host connections. When a 97th connection is attempted, the connection name capacity of HSG80 controllers is exceeded. This can result in a controller fatal error.

In DRM mode, two host ports are active. One server with two HBAs has two data paths, one for each HBA. Each HBA on the fabric creates one connection per controller pair. Four connections are also created for initiator-controller-to-target-controller communication.

Switch zoning must be used to prevent more than 96 host connections to a single storage system. This allows more servers to be attached to the SAN to use other storage systems.

Zoning Hosts and HSG80 Subsystems Between Sites

In a DRM configuration, the initiator hosts are zoned so that they do not have access to the target controllers; the target hosts are zoned so that they do not have access to the initiator controllers.

There are circumstances, however, when the hosts at one site do require access to HSG80 controller pairs at both sites. This could occur when you are running scripts, OpenVMS host-based shadowing, or stretch clusters. If that is the case, go to the section “Zoning to Allow Host Access Between Sites” on page 8–30.

Zoning A DRM Configuration

This section provides zoning examples for both homogeneous and heterogeneous configurations.

DRM Homogeneous Configuration

The Fibre Channel fabric can be customized for zoning in numerous ways. The DRM uses for zoning include:

- Creating fabric functional areas by separating test or maintenance areas from production areas.
- Designating closed user groups by including certain zone devices for exclusive use by zone members.
- Simplifying resource utilization by logically consolidating equipment for convenience.
- Facilitating time-sensitive functions by creating a temporary zone to back up a set of devices that are members of other zones.
- Securing fabric areas by providing another level of software security to control port level access.
- Separating operating system types and applications to control access to resources.

This section provides examples of zoning a DRM configuration. The examples begin with the configuration of a DRM homogeneous environment. Additional examples create a DRM heterogeneous environment from the homogeneous environment.

The examples are from a telnet session on a Fibre Channel storage switch that is case sensitive. Other switches may not be case sensitive. If you want to use the Web Management Tool, refer to the *Compaq StorageWorks SAN Switch Web Management Tools Reference Guide* for help and follow the same steps provided in these telnet examples.

Figure 8–1 shows a simplified DRM configuration that consists of six zones. For this example, the zones are designated Green Zone_Top and Green Zone_Bottom for the initiator site; Blue Zone_Top and Blue Zone_Bottom for the target site; and Red Zone_Top and Red Zone_Bottom, which contain the remote copy sets or paths.

NOTE: Zones are given color names in this document only as examples. You should choose names that are meaningful for your environment.

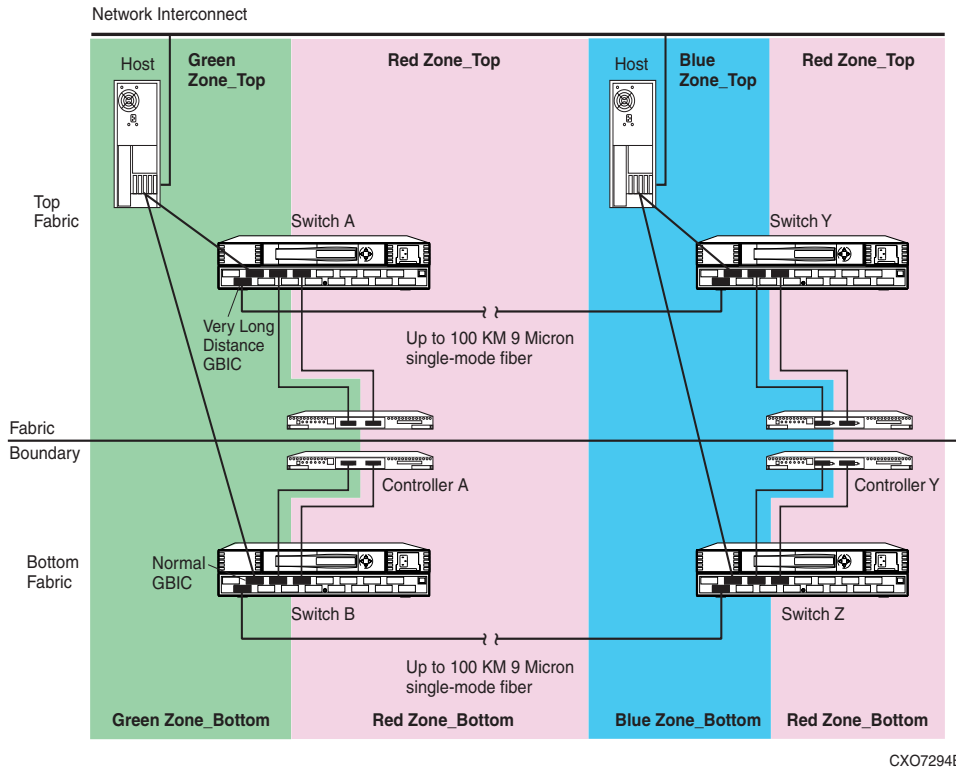

CX07294B

Figure 8–1: Zoning in a DRM homogeneous environment

Compaq suggests that you use Table 8–1, the zoning input form, to capture and track the required device and command information. The form supports two paths, two switches, and a maximum of 16 entries per switch. Copy and use a separate form to track information for each zone (such as Green Zone_Top, Blue Zone_Top, Red Zone_Top, and so on). Organize alias name, function, and site data by either World Wide ID (WWID) number or Port ID number.

Table 8-1: Blank zoning input form template

Zoning Configuration Name =

Zone Name=	Switch Name=	Path=			
WWID #	Domain ID #	Port #	Alias Name	Function	Site

Zoning Configuration Name =

Zone Name=	Switch Name=	Path=			
WWID #	Domain ID #	Port #	Alias Name	Function	Site

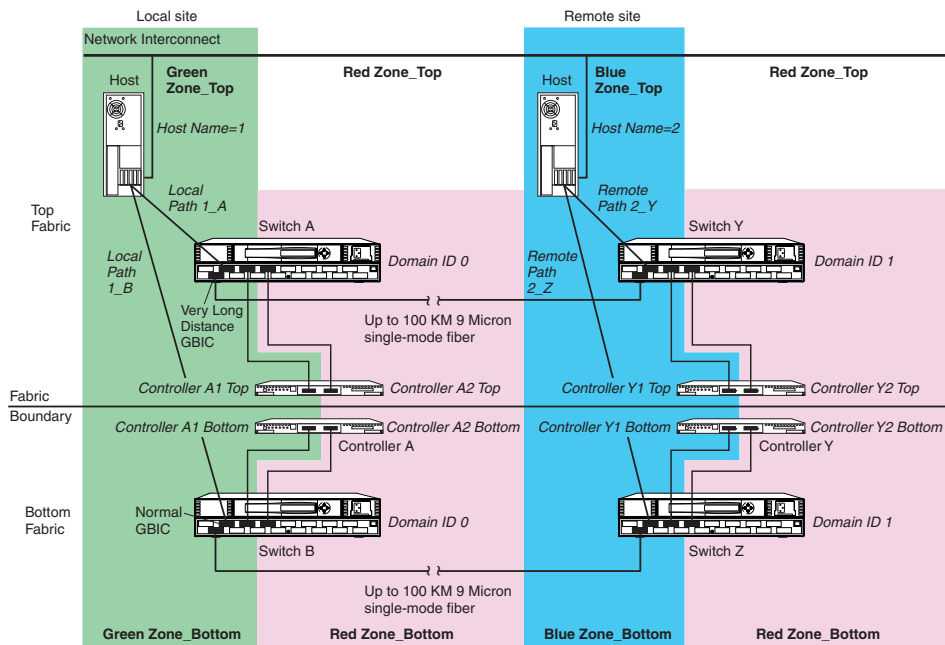

CXO7679A

Figure 8–2: Zoning a DRM example

Figure 8–2 shows a zoned example for a Data Replication Manager configuration. The steps required to produce this zoning configuration are on the following pages. Since multiple configurations can be created and saved, the one currently in use is known as the *effective configuration*. The process to create and save an effective configuration that ensures the switches are enabled after reboot or shutdown, includes the following:

1. Begin by zoning the top fabric initiator site (designated in the example as Green Zone_Top).
2. Zone the top fabric target site (designated as Blue Zone_Top).
3. Zone the remote copy sets or paths for the top fabric (designated as Red Zone_Top).
4. Zone the three zones for the bottom fabric.

The next three examples illustrate these zoning practices.

Example: Zoning Green Zone_Top and Green Zone_Bottom

Table 8–2, the Green Zone_Top and Green Zone_Bottom input form, is created from a blank template (Table 8–1) and is added to throughout this example.

Table 8–2: Green Zone_Top and Green Zone_Bottom input form

Zoning Configuration Name=Top_Fabric

Zone Name=Green Zone_Top Switch Name=Switch A Path=A

WWID #	Domain ID #	Port #	Alias Name	Function	Site
	0	1	—	E-Port	Local
	0	2	Host 1_A	Host	Local
	0	4	Controller A1_top	Controller	Local

Zoning Configuration Name=Bottom_Fabric

Zone Name=Green Zone_Bottom Switch Name=Switch B Path=B

WWID #	Domain ID #	Port #	Alias Name	Function	Site
	0	1	—	E-Port	Local
	0	2	Host 1_B	Host	Local
	0	4	Controller A1_bottom	Controller	Local

Figure 8–2 shows zoning using the Domain ID number and the Port number, rather than the WWID number. The WWID could also have been used. A general rule is that if you are changing connections within DRM, use the WWID for zoning.

1. Identify and write down the Domain ID of each switch. To get this information, use the `switchShow` command from each switch in a telnet session or from the front console of each switch. The example in Figure 8–2 shows that switches A and B both have a Domain ID of 0.

NOTE: Refer to the *Compaq StorageWorks Fibre Channel SAN Switch Management Guide* for telnet session procedures.

After logging this information on a blank template form, give it the zone name “Green Zone_Top.” On this form, list the Green Zone in two blocks, one for switch A in Green Zone_Top, and one for switch B in Green Zone_Bottom (see Table 8–2).

2. Log the ports that connect to the hosts and E-Ports.

Figure 8–2 shows that “Host 1” is the host name and that there are two connections from Host 1 to the switches. Host 1 path 1_A is connected to port 2 of switch A, and Host 1 path 1_B is connected to port 2 of switch B. The E-Port is located in port 1 on both switches A and B.

3. List the controller connections for the top and bottom fabrics.

From the example in Figure 8–2, the controller pair is listed as Controller A1_top (top controller, port 1), and Controller A1_bottom (bottom controller port 1). Switch A port 4 connects to Controller A1_top in the top fabric. Switch B port 4 connects to Controller A1_bottom in the bottom fabric.

4. Open a telnet session to switch A.
5. Create the alias names in the zone. The naming convention in the example refers to Host 1_A as the host name and path for the connection to port 2 of switch A. The command for this alias is:

```
aliCreate "Host 1_A", "0,2"
```

This means that an alias is generated named “Host 1_A” with switch domain 0 and port number 2.

IMPORTANT: Be sure to issue all `aliCreate`, `ZoneAdd`, and `CfgAdd` commands from a switch within the fabric for which the alias is being created. For example, issue commands from switch A for the top fabric, and from switch B for the bottom fabric.

6. The next alias is for controller A1_top. The command for this alias is:

```
aliCreate "Controller A1_top", "0,4"
```

This generates an alias named “Controller A1_top” with switch domain 0 and port number 4.

Since E-Ports cannot be zoned, an alias is not needed for domain 0 port 1 in this example.

7. Save the configuration:

```
cfgSave
```

NOTE: Compaq recommends that you use the `cfgShow` command after every `cfgSave` command to verify that the previous commands have been accepted.

8. The next alias to create is from switch B. Open a telnet session to switch B.

9. Create the Host 1_B alias:

```
aliCreate "Host 1_B", "0,2"
```

10. Create the controller A-1 bottom alias:

```
aliCreate "Controller A1_bottom", "0,4"
```

11. Save the configuration:

```
cfgSave
```

This completes alias naming for the Green Zones. The next section configures the Blue Zones.

Example: Zoning Blue Zone_Top and Blue Zone_Bottom

Zoning the Blue portion of this example is similar to the steps for the Green Zone, with a few name and number changes. See Table 8–3 for the sample Blue Zone_Top and Blue Zone_Bottom input form.

Table 8–3: Blue Zone_Top and Blue Zone_Bottom input form

Zoning Configuration Name=Top_Fabric

Zone Name=Blue Zone_Top

Switch Name=Switch Y

Path=A

WWID #	Domain ID #	Port #	Alias Name	Function	Site
	1	1	—	E-Port	Remote
	1	2	Host 2_Y	Host	Remote
	1	4	Controller Y1_top	Controller	Remote

Zoning Configuration Name=Bottom_Fabric

Zone Name=Blue Zone_Bottom

Switch Name=Switch Z

Path=B

WWID #	Domain ID #	Port #	Alias Name	Function	Site
	1	1	—	E-Port	Remote
	1	2	Host 2_Z	Host	Remote
	1	4	Controller Y1_bottom	Controller	Remote

As shown in Figure 8–2, the Host in the Blue Zone is named “Host 2.”

1. Log the domain IDs of switches Y and Z. In this example, they are both Domain ID 1.

Log this information in the Blue Zone_Top and Blue Zone_Bottom input form. On this input form, list the Blue Zone in two blocks, one for switch Y in Blue Zone_Top and one for switch Z in Blue Zone_Bottom. See Table 8–3 for entries.

2. Log the ports that connect to the hosts and E ports.

Figure 8–2 shows that “Host 2” is the host name and that there are two connections from Host 2 to the switches. Host 2 path 2_Y is connected to port 2 of switch Y; Host 2 path 2_Z is connected to port 2 of switch Z. The E-Port is located in port 1 on both switches Y and Z.

3. List the controller connections for the top and bottom fabrics.

Figure 8–2 shows that the controller pair is listed as Controller Y1_top (top controller, port 1), and Controller Y1_bottom (bottom controller, port 1). Switch Y port 4 connects to Controller Y1_top in the top fabric. Switch Z port 4 connects to Controller Y1_bottom in the bottom fabric.

4. Select the telnet session from switch A.
5. Create the alias names in the zone.

The naming convention in the example refers to Host 2_Y as the host name and path for the connection to port 2 of switch Y. The command for this alias is:

```
aliCreate "Host 2_Y", "1,2"
```

This generates an alias named “Host 2_Y,” with a switch domain of 1 and port number 2.

6. The next alias is for Controller Y1_top:

```
aliCreate "Controller Y1_top", "1,4"
```

This generates an alias named “Controller Y1_top,” with a switch domain of 1 and port number 4.

Since E ports cannot be zoned, an alias is not needed for domain 1 port 1.

7. Save the configuration:

```
cfgSave
```

8. The next alias to create is from switch Z. Open a telnet session to switch B.

9. Create the Host 2_Z alias:

```
aliCreate "Host 2_Z", "1,2"
```

10. Create the controller Y1_bottom alias:

```
aliCreate "Controller Y1_bottom", "1,4"
```

11. Save the configuration:

```
cfgSave
```

This completes the alias naming for the Blue Zones. The next section configures the Red Zones.

Example: Zoning Red Zone_Top and Red Zone_Bottom

Zoning the Red Zone portion of this example is similar to zoning the Blue and Green Zones, with a few exceptions. See Table 8-4 for the sample Red Zone_Top and Red Zone_Bottom input form.

Table 8–4: Red Zone_Top and Red Zone_Bottom input form

Zoning Configuration Name=Top_Fabric

Zone Name=Red Zone_Top Switch Name=Switch A&Y Path=A&B

WWID #	Domain ID #	Port #	Alias Name	Function	Site
	0	6	Controller A2_top	Controller	Local
	1	6	Controller Y2_top	Controller	Remote

Zoning Configuration Name=Bottom_Fabric

Zone Name=Red Zone_Bottom Switch Name=Switch B&Z Path=A&B

WWID #	Domain ID #	Port #	Alias Name	Function	Site
	0	6	Controller A2_bottom	Controller	Local
	1	6	Controller Y2_bottom	Controller	Remote

As shown in Figure 8–2, the Red Zone contains only switch ports and controller ports. It contains no hosts.

These are the DRM remote copy paths:

As shown earlier, switches A and B are Domain ID 0; switches Y and Z are Domain ID 1.

1. List switch domains A and Y in the Red Zone_Top input form. List switch Domains B and Z in the Red Zone_Bottom form.
2. List the controller connections.

Figure 8–2 shows the controller pair listed as: Controller A2_top (top A controller, port 2) and Controller Y2_top (top Y controller, port 2).

- a. List these two connections in the Red Zone_Top input form.
- b. List Controller A2_bottom (meaning bottom A controller, port 2) and Controller Y2_bottom (meaning bottom Y controller, port 2) in the Red Zone_Bottom input form.

Switch A, port 6 connects to Controller A2_top. Switch Y, port 6 connects to Controller Y2_top. Switch B, port 6 connects to Controller A2_bottom. Switch Z, port 6 connects to Controller Y2_bottom.

3. Select the telnet session from switch A.
4. Create the alias names in the zone. For the connections from switches A and Y to the controllers A2_top and Y2_top, the commands are:

```
aliCreate "Controller A2_top", "0,6"  
aliCreate "Controller Y2_top", "1,6"
```

These commands create the alias “Controller A2_top” with Domain ID 0 and switch port 6; and the alias “Controller Y2_top” with Domain ID 1 and switch port 6.

5. Save the configuration:
6. Select the telnet session to switch B.
7. For the connections from switches B and Z to the controllers A2_bottom and Y2_bottom, enter the following commands:

```
aliCreate "Controller A2_bottom", "0,6"  
aliCreate "Controller Y2_bottom", "1,6"
```

These commands create the alias “Controller A2_bottom” with Domain ID 0 and switch port 6; and the alias “Controller Y2_bottom” with Domain ID 1 and switch port 6.

8. Save the configuration:

```
cfgSave
```

Create the Zone Names

1. Select the telnet session from switch A.

2. Create the Green Zone_Top name and add the zone members:

```
zoneCreate "Green Zone_Top", "Host 1_A; Controller A1_top"
```

3. Create the Blue Zone_Top name and add the zone members:

```
zoneCreate "Blue Zone_Top", "Host 2_Y; Controller Y1_top"
```

4. Create the Red Zone_Top name and add the zone members:

```
zoneCreate "Red Zone_Top", "Controller A2_top; Controller Y2_top"
```

These three steps create the zone names that are stored in flash memory in both switches A and Y. The next step is to repeat these commands for switches B and Z.

5. Save the configuration:

```
cfgSave
```

6. Select the telnet session from switch B.

7. Create the Green Zone_Bottom name and add the zone members:

```
zoneCreate "Green Zone_Bottom", "Host 1_B; Controller A1_bottom"
```

8. Create the Blue Zone_Bottom name and add the zone members:

```
zoneCreate "Blue Zone_Bottom", "Host 2_Z; Controller Y1_bottom"
```

9. Create the Red Zone_Bottom name and add the zone members:

```
zoneCreate "Red Zone_Bottom", "Controller A2_bottom;  
Controller Y2_bottom"
```

These three steps create the zone names that are stored in flash memory in both switches B and Z.

10. Save the configuration:

```
cfgSave
```

Create the Configuration Name

1. Select the telnet session from switch A.
2. Create the configuration using “Top_Fabric” as the example name and add all of the zone members. The command is:

```
cfgCreate "Top_Fabric", "Green Zone_Top; Blue Zone_Top; Red  
Zone_Top"
```

This creates a configuration file titled “Top_Fabric,” which contains Green Zone_Top, Blue Zone_Top, Red Zone_Top, and their alias members. These are stored in flash memory for switches A and Y.

3. Save the configuration:

```
cfgSave
```

4. Enable the new zone configuration with the following command:

```
cfgEnable "Top_Fabric"
```

This now becomes the effective (in use) configuration for both switches A and Y.

5. To make this the active configuration after a restart or power down, issue one final `cfgSave` command:

```
cfgSave
```

This ensures the effective configuration of the switches after a restart or power down.

6. Select the telnet session from switch B.
7. Create the configuration using “Bottom_Fabric” as the filename and add all of the zone members. The command is:

```
cfgCreate "Bottom_Fabric", "Green Zone_Bottom; Blue Zone_Bottom;  
Red Zone_Bottom"
```

This creates a configuration file titled “Bottom_Fabric,” which contains Green Zone_Bottom, Blue Zone_Bottom, Red Zone_Bottom, and their alias members. these are stored in flash memory for switches B and Z.

8. Save the configuration:

```
cfgSave
```

9. Enable the new zone configuration with the following command:

```
cfgEnable "Bottom_Fabric"
```

This now becomes the effective (in use) configuration for both switches B and Z.

10. To make this the active configuration after a restart or power down, issue one final `cfgSave` command:

```
cfgSave
```

This ensures the effective configuration of the switches after a restart or power down.

Zoning for a DRM homogeneous configuration is now complete.

DRM Heterogeneous Configuration

A DRM heterogeneous configuration consists of multiple operating systems sharing the same pair of storage arrays. A DRM heterogeneous configuration can be created from a DRM homogeneous configuration. This is done by adding zones that consist of new servers or clusters of a different operating system type from those in the original DRM homogeneous configuration. These new zones share the same storage arrays and isolate the additional operating system from the original operating system.

This section shows the steps to add zones from a DRM homogeneous configuration to create a DRM heterogeneous configuration. These same steps can be applied to an existing DRM heterogeneous configuration to add a new operating system.

If you are adding new zones to an existing DRM configuration, read from the beginning of this section, “Zoning A DRM Configuration” on page 8–3. This will help you understand the configuration examples and naming conventions. Figure 8–3 shows the additional four zones created. These zones are named, for this example, “Yellow Zone_Top” and “Yellow Zone_Bottom” (for the initiator site); “Brown Zone_Top” and “Brown Zone_Bottom” (for the target site). Use Figure 8–1 along with Figure 8–3 to picture the zoning scheme of a DRM heterogeneous configuration.

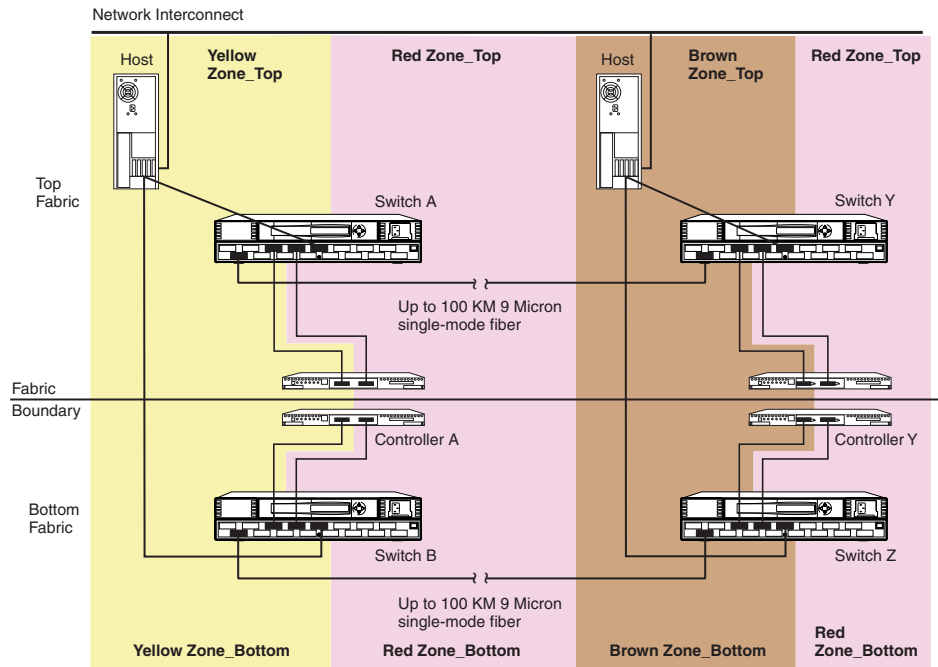

CXO7680A

Figure 8-3: Zoning in a DRM heterogeneous environment

Use Table 8-1, the blank zoning input form template, to record and track the required device and command information. The form is designed to support two paths, two switches, and a maximum of 16 entries per switch. Copy and use a separate form to track information for each zone (such as Yellow Zone_Top, Brown Zone_Bottom, and so on). Organize alias name, function, and site data by either WWID number or Port ID number.

Figure 8-4 shows an example of the additional zones created for a DRM heterogeneous configuration.

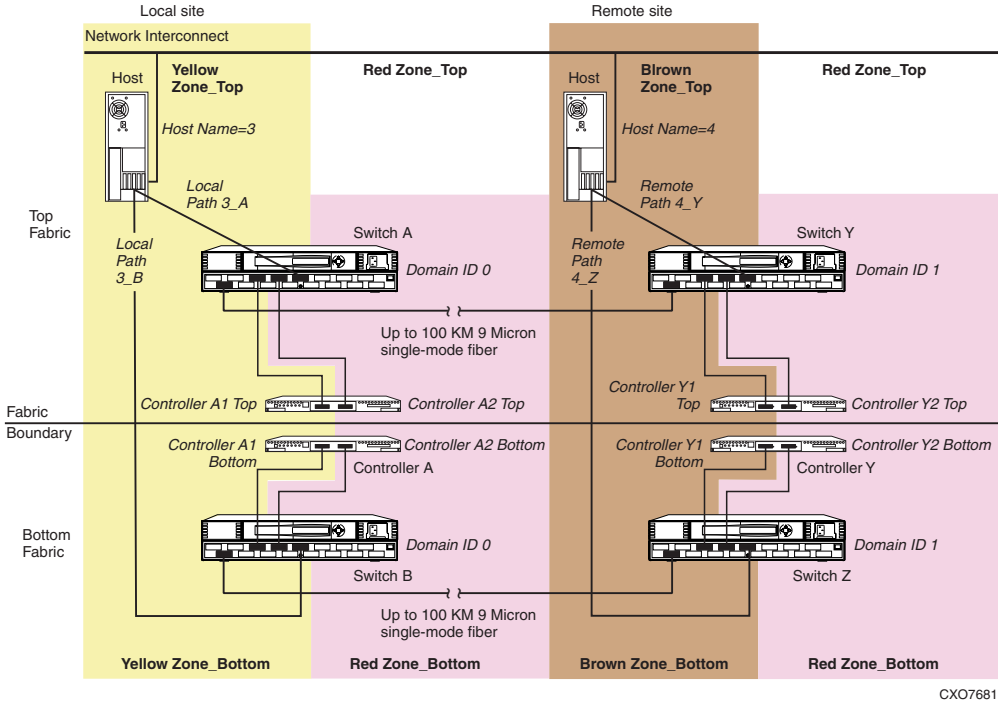

Figure 8-4: DRM example showing the new zones

The following sections contain the process that creates the zoning configuration illustrated in Figure 8-4. Since multiple configurations can be created and saved, the one currently in use is known as the *effective configuration*. The process to create and save an effective configuration (that ensures the switches are enabled after reboot or shutdown) includes the following:

1. Zoning the top fabric initiator site (designated “Yellow Zone_Top”)
2. Zoning the top fabric target site (designated “Brown Zone_Top”)
3. Zoning the two zones for the bottom fabric.

Two examples follow that illustrate these zoning concepts.

Example: Zoning Yellow Zone_Top and Yellow Zone_Bottom

Table 8-5, the Yellow Zone_Top and Yellow Zone_Bottom input form, is created from the blank template (Table 8-1) and is added to during this example.

Table 8–5 shows zoning using the Domain ID number and Port number, rather than the WWID number. The WWID could also have been used. A general rule is that if you are changing connections within the DRM, use the WWID for zoning. If you are changing out hardware, use the Domain ID and Port number. The zoning procedure follows.

1. Identify and record the Domain ID of each switch. To get this information, use the `switchShow` command from each switch in a telnet session or from the front console of each switch. The example in Figure 8–4 shows that switches A and B both have a Domain of 0.

After recording this information on a blank template form, give it the zone name “Yellow Zone_Top.” On the form, list the Yellow Zone in two blocks, one for switch A in `Yellow Zone_Top` and one for switch B in `Yellow Zone_Bottom` (see Table 8–5).

2. Record the ports that connect to the hosts and E ports.

Figure 8–4 shows that “Host 3” is the host name and there are two connections from Host 3 to the switches. Host 3 path 3_A is connected to port 8 of switch A; Host 3 path 3_B is connected to port 8 of switch B. The E-Port is located in port 1 of both switches A and B.

3. List the controller connections for the top and bottom fabrics.

In Figure 8–4, the controller pair is listed as Controller A1_top (top controller, port 1) and Controller A1_bottom (bottom controller, port 1). Switch A, port 4 connects to Controller A1_top in the top fabric. Switch B, port 4 connects to Controller A1_bottom in the bottom fabric.

4. Open a telnet session to switch A.
5. Create the alias names in the zone. The naming convention in the example refers to Host 3_A as the host name and path used for the connection to port 8 of switch A. The command for this alias is:

```
aliCreate "Host 3_A", "0,8"
```

This command creates an alias named “Host 3_A” with switch domain 0 and port number 8.

IMPORTANT: Be sure to issue all `aliCreate`, `ZoneAdd`, and `CfgAdd` commands from a switch within the fabric for which the alias is being created. For example, issue commands from switch A for the top fabric and from switch B for the bottom fabric.

NOTE: The controller alias “Controller A1_Top” has already been created and does not need to be repeated. Since E ports cannot be zoned, an alias is not needed for domain 0, port 1 on switch A.

6. Save the configuration:

```
cfgSave
```

NOTE: Compaq recommends that you issue a `cfgShow` command after every `cfgSave` and verify the previous commands.

7. The next alias to create is from switch B. Open a telnet session to switch B.
8. Create the Host 3_B alias with the command:

```
aliCreate "Host 3_B", "0,8"
```

NOTE: The controller alias "Controller A1_Bottom" has already been created and does not need to be repeated.

9. Save the configuration:

```
cfgSave
```

This completes alias naming for the Yellow Zones. The next section configures the Brown Zones.

Example: Zoning Brown Zone_Top and Brown Zone_Bottom

Zoning the Brown portion of this example is similar to zoning the Yellow portion, with a few name and number changes. Table 8-6 shows the sample Brown Zone_Top and Brown Zone_Bottom input form.

Figure 8–4 shows that the host in the Brown Zone is named “Host 4.” The zoning procedure follows.

1. Record the domain IDs of switches Y and Z. In this example, they are both Domain ID 1.

Record this information in the `Brown Zone_Top` and `Brown Zone_Bottom` input form. List the Brown Zone in two blocks, one for switch Y in `Brown Zone_Top` and one for switch Z in `Brown Zone_Bottom`. See Table 8–6 for entries.

2. Record the ports that connect to the hosts and E ports.

Figure 8–4 shows that “Host 4” is the host name and that there are two connections from Host 4 to the switches. Host 4 path 4_Y is connected to port 8 of switch Y; Host 4 path 4_Z is connected to port 8 of switch Z. The E-Port is located in port 1 on both switches Y and Z.

3. List the controller connections for the top and bottom fabrics.

Figure 8–4 shows that the controller pair is listed as `Controller Y1_top` (top controller, port 1) and `Controller Y1_bottom` (bottom controller, port 1). Switch Y port 4 connects to `Controller Y1_top` in the top fabric. Switch Z connects to `Controller Y1_bottom` in the bottom fabric.

4. Select the telnet session from switch A.
5. Create the alias names in the zone.

The naming convention in the example refers to “Host 4_Y” as the host name and path for the connections to port 8 of switch Y. The command to create this alias is:

```
aliCreate "Host 4_Y", "1,8"
```

This command creates an alias named “Host 4_Y” with a switch domain of 1 and port number 8.

NOTE: The controller alias “Controller Y1_Top” has already been created and does not need to be repeated. Since E ports cannot be zoned, an alias is not needed for domain 1 port 1.

6. Save the configuration:

```
cfgSave
```

7. The next alias to create is from switch Z. Open a telnet session to switch B.
8. Create the Host 4_Z alias:

```
aliCreate "Host 4_Z", "1,8"
```

NOTE: The controller alias “Controller Y1_Bottom” has already been created and does not need to be repeated.

9. Save the configuration:

```
cfgSave
```

This completes alias naming for the Brown Zones.

NOTE: The Red Zones have already been created, so the port aliases for the Red Zone ports do not need to be repeated.

Create the Zone Names

1. Select the telnet session from switch A.

2. Create the Yellow Zone_Top name and add the zone numbers:

```
zoneCreate "Yellow Zone_Top", Host 3_A; Controller A1-top"
```

3. Create the Brown Zone_Top name and add the zone numbers:

```
zoneCreate "Brown Zone_Top", "Host 4_Y; Controller Y1_top"
```

NOTE: Red Zone_Top has already been created and does not need to be repeated.

These two steps created the zone names that are stored in flash memory in both switches A and Y. The next step is to repeat these two commands for switches B and Z.

4. Save the configuration:

```
cfgSave
```

5. Select the telnet session from Switch B.

6. Create the Yellow Zone_Bottom name and add the zone numbers:

```
zoneCreate "Yellow Zone_Bottom", "Host 3_B; Controller A1_Bottom"
```

7. Create the Brown Zone_Bottom name and add the zone numbers:

```
zoneCreate "Brown Zone_Bottom", "Host 4_Z; Controller Y1_Bottom"
```

NOTE: "Red Zone_Bottom" has already been created and does not need to be repeated.

These two steps created the zone names that are stored in flash memory in both switches B and Z.

8. Save the configuration:

```
cfgSave
```

Add the New Zones to the Configuration

1. Select the telnet session from switch A.
2. Add the new top zones to the configuration Top_Fabric:

NOTE: Top_Fabric has already been created

```
cfgAdd "Top_Fabric", "Yellow Zone_Top; Brown Zone_Top"
```

This adds Yellow Zone_Top and Brown Zone_Top to a configuration file titled "Top_Fabric," which already contains Green Zone_Top, Blue Zone_Top, Red Zone_Top, and their alias members. These are stored in flash memory for switches A and Y.

3. Save the configuration:

```
cfgSave
```

4. Enable the new zone configuration:

```
cfgEnable "Top_Fabric"
```

NOTE: This configuration now becomes the effective (in use) configuration for both switches A and Y.

5. To make this the active configuration after a restart or power down, issue another cfgSave command:

```
cfgSave
```

This ensures the effective configuration of the switches after a restart or power down.

6. Verify that the Top_Fabric configuration is correct:

```
cfgShow
```

The system produces a display of the Top_Fabric configuration similar to the following:

Defined configuration:

```
cfg: Top_Fabric
    Blue Zone_Top; Brown Zone_Top; Green Zone_Top;
    Red Zone_Top; Yellow Zone Top
zone: Blue Zone_Top
    . . . . . Host 2_Y; Controller Y1_top
zone: Brown Zone_Top
    Host 4_Y; Controller Y1_top
zone: Green Zone_Top
```

```
Host 1_A; Controller A1_top
zone: Red Zone_Top
    Controller A2_top; Controller Y2_top
zone: Yellow Zone_Top
    Host 3_A; Controller A1_top
alias: Controller A1_top
    0,4
alias: Controller A2_top
    0,6
alias: Controller Y1_top
    1,4
alias: Controller Y2_top
    1,6
alias: Host 1_A
    0,2
alias: Host 2_Y
    1,2
alias: Host 3_A
    0,8
alias: Host 4_Y
    1,8
Effective configuration:
cfg: Top_Fabric
zone: Blue Zone_Top
    . . . . . 1,2
    1,4
zone: Brown Zone_Top
    1,8
    1,4
zone: Green Zone_Top
    0,2
    0,4
zone: Red Zone_Top
    0,6
```

```
1,6
zone: Yellow Zone_Top
0,8
0,4
```

7. Select the telnet session from switch B.
8. Add the new bottom zones to the configuration Bottom_Fabric:

NOTE: The Bottom_Fabric has already been created.

This adds Yellow Zone_Bottom and Brown Zone_Bottom to a configuration file titled “Bottom_Fabric,” which already contains Green Zone_Bottom, Blue Zone_Bottom, Red Zone_Bottom, and their alias members. These are stored in flash memory for switches B and Z.

9. Save the configuration:

```
cfgSave
```

10. Enable the new zone configuration:

```
cfgEnable "Bottom_Fabric"
```

NOTE: This configuration now becomes the effective (in use) configuration for both switches B and Z.

11. To make this the active configuration after a restart or power down, issue another cfgSave command:

```
cfgSave
```

This ensures the effective configuration of the switches after a restart or power down.

12. Verify that the Bottom_Fabric configuration is correct:

```
cfgShow
```

The system produces a display of the Bottom_Fabric configuration similar to the following:

```
Defined configuration:
```

```
cfg: Bottom_Fabric
    Blue Zone_Bottom; Brown Zone_Bottom; Green Zone_Bottom
    Red Zone_Bottom; Yellow Zone_Bottom
zone: Blue Zone_Bottom
    Host 2_Z; Controller Y1_bottom
zone: Brown Zone_Bottom
```

```
Host 4_Z; Controller Y1_bottom
zone: Green Zone_Bottom
Host 1_B; Controller A1_bottom
zone: Red Zone_Bottom
Controller A2_bottom; Controller Y2_bottom
zone: Yellow Zone_Bottom
Host 3_B; Controller A1_bottom
alias: Controller A1_bottom
0,4
alias: Controller A2_bottom
0,6
alias: Controller Y1_bottom
1,4
alias: Controller Y2_bottom
1,6
alias: Host 1_B
0,2
alias: Host 2_Z
1,2
alias: Host 3_B
0,8
alias: Host 4_Z
1,8
```

Effective configuration:

```
cfg: Bottom_Fabric
zone: Blue Zone_Bottom
1,2
1,4
zone: Brown Zone_Bottom
1,8
1,4
zone: Green Zone_Bottom
0,2
```

```
    0,4
zone: Red Zone_Bottom
    0,6
    1,6
zone: Yellow Zone_Bottom
    0,8
    0,4
```

Zoning for a DRM heterogeneous configuration is now complete. If you want to add additional zones, repeat the steps starting at the section titled “DRM Heterogeneous Configuration.”

Zoning to Allow Host Access Between Sites

The previous examples in this chapter are zoned so that the hosts at one site do not have access to controllers at the other site. The following example shows how to enable access of Host 1 in the Green Zone by Controller Y and Host 2 in the Blue Zone by Controller A.

1. Open a telnet session to switch A.
2. Add a new zone member of Controller Y’s top port 1 to the Green Zone Top:

```
zoneAdd "Green Zone_Top", "Controller Y1_top"
```
3. Add a new zone member of Controller A’s top port 1 to the Blue Zone Top:

```
zoneAdd "Blue Zone_Top", "Controller A1_top"
```
4. Enable the new zone configurations:

```
cfgEnable "Top_Fabric"
```
5. Save the configuration:

```
cfgSave
```
6. Open a telnet session to switch B.
7. Add a new zone member of Controller Y’s bottom port 1 to the Green Zone Bottom:

```
zoneAdd "Green Zone_Bottom", "Controller Y1_bottom"
```
8. Add a new zone member of Controller A’s bottom port 1 to the Blue Zone Bottom:

```
zoneAdd "Blue Zone_Bottom", "Controller A1_bottom"
```

9. Enable the new zone configurations:

```
cfgEnable "Bottom_Fabric"
```

10. Save the configuration:

```
cfgSave
```

Controller members from one site have now been added to the host zones at the other site. Repeat the procedure if other zones at one site need access to controllers at the other site.

Status Comparison

This appendix describes the procedure for comparing the status of:

- Controllers
- Association sets
- Remote copy sets
- Units
- Connections

Performing a status comparison consists of the following procedures:

- Target Site Terminal Emulator Session
- Issuing SHOW Commands

Target Site Terminal Emulator Session

1. Using a serial cable, connect the COM port of a laptop computer or another computer to the corresponding serial port on the HSG80 controllers.
2. Start a terminal emulator session that is capable of capturing text to a file (which is later saved as step 6 of the SHOW Commands procedure). Use the settings: 9600 baud, 8 bits, no parity, 1 stop bit, XON/XOFF.

Issuing SHOW Commands

1. To see the full information on this controller, issue the CLI command:

```
SHOW THIS_CONTROLLER FULL
```

You should see a display similar to that shown in Example Display 1.

2. To see the information for all association sets known to the controller pair, issue the CLI command:

```
SHOW ASSOCIATIONS FULL
```

You should see a display similar to that of Example Display 2 for each association set.

3. To see information for all remote copy sets known to the controller pair, issue the CLI command:

```
SHOW REMOTE_COPY FULL
```

You should see a display similar to that in Example Display 3 for each remote copy set.

4. To see information for all units configured to the controller, issue the CLI command:

```
SHOW UNITS FULL
```

You should see a display similar to that of Example Display 4 for each unit.

5. To see the connection name, operating system, controller, controller port, adapter ID address, online or offline status, and unit offset, issue the CLI command:

```
SHOW CONNECTIONS
```

You should see a display similar to that of Example Display 5 for each connection.

6. Print and save two copies of the file started during the terminal emulator session procedure (step 2). Save one copy at each site. This file contains the text captured in steps 1-5 of the SHOW commands.

Example Display 1 corresponds to step 1 of the “Issuing SHOW Commands” section:

Example Display 1

Controller:

```
HSG80 ZG91412410 Software V85P, Hardware E05
NODE_ID          = nnnnnnnnnnn
ALLOCATION_CLASS = 0
SCSI_VERSION     = SCSI-2
Configured for MULTIBUS_FAILOVER with ZG91416136
    In dual-redundant configuration
Device Port SCSI address 6
Time: NOT SET
```

```
Command Console LUN is lun 0 (NOIDENTIFIER)
Host PORT_1:
  Reported PORT_ID = 5000-1FE1-0001-3AE1
  PORT_1_TOPOLOGY = FABRIC (fabric up)
  Address          = 220113
Host PORT_2:
  Reported PORT_ID = 5000-1FE1-0001-3AE2
  PORT_2_TOPOLOGY = FABRIC (fabric up)
  Address          = 220313
  REMOTE_COPY     = BuildingB
Cache:
  256 megabyte write cache, version 0012
  Cache is GOOD
  No unflushed data in cache
  CACHE_FLUSH_TIMER = DEFAULT (10 seconds)
Mirrored Cache:
  256 megabyte write cache, version 0012
  Cache is GOOD
  No unflushed data in cache
Battery:
  NOUPS
  FULLY CHARGED
  Expires:

Extended information:
  Terminal speed 9600 baud, eight bit, no parity, 1 stop bit
  Operation control: 00000000 Security state code: 75184
  Configuration backup disabled
```

Example Display 2 corresponds to step 2 of the “Issuing SHOW Commands” section:

Example Display 2

Name	Association	Uses	Used by
AS1	association	RC1 RC2 RC3	
Switches:			
NOFAIL_ALL			
NOORDER_ALL			
NOLOG_UNIT			

Example Display 3 corresponds to step 3 of the “Issuing SHOW Commands” section:

Example Display 3

Name		Uses	Used by
RC1	remote copy	D1	AS1
Reported LUN ID: nnnnnnnnnnnnnnn			
Switches:			
OPERATION_MODE = SYNCHRONOUS			
ERROR_MODE = NORMAL			
FAILOVER_MODE = MANUAL			
OUTSTANDING_IOS = 60			
.			
.			
.			

Example Display 4 corresponds to step 4 of the “Issuing SHOW Commands” section:

Example Display 4

```

D2                                DISK10100          BuildingB\RC2

LUN ID: nnnnnnnnnnnnnnnnnnnnnnnn
NOIDENTIFIER
Switches:
  RUN                               NOWRITE_PROTECT      READ_CACHE
  READAHEAD_CACHE                   WRITEBACK_CACHE
  MAXIMUM_CACHED_TRANSFER_SIZE = 1

Access:
BuildngAA, BuildngAB, BuildngAC, BuildngAD, HostCon_1, HostCon_2

State:
  ONLINE to this controller
  Not reserved
  PREFERRED_PATH = OTHER_CONTROLLER
  Target NORMAL

Size:                               17769177 blocks

Geometry (C/H/S): ( 5258 / 20 / 169 )

```

Example Display 5 corresponds to step 5 of the “Issuing SHOW Commands” section:

Example Display 5

```

Connection                                Unit
Name Operating system Controller Port    Address  Status
Offset !NEWCON28 WINNT                   THIS    1      634000  OL this    0
HOST_ID=1000-0000-C921-4B5B ADAPTER_ID=1000-0000-C921-4B5B.

```

Replicating Storage Units

This chapter describes Data Replication Manager (DRM) concepts and procedures for making point-in-time copies of a storage unit.

The topics discussed in this chapter are:

- “Cloning Data for Backup” on page B-3
- “Snapshot” on page B-6

Cloning and *Snapshot* are methods of making a point-in-time copy of a storage unit. Table B-1 provides an overview comparison of the two methods.

Table B-1: Cloning and Snapshot Comparison

Cloning	Snapshot
Can be performed at Initiator site or Target site.	Can be performed at Target site only.
<ul style="list-style-type: none"> • A physical copy that resides on disk. • Can be a source for another clone. • Source and Cloned units. 	<ul style="list-style-type: none"> • A virtual copy that resides on disk and in cache. • May not be snapped or cloned. • Requires 512 MB cache for both controllers.
Read/Write capability.	Read/Write capability.
Data captured in hours (for moderate I/O loads, possibly at a rate of 60 GB/hour).	Data captured in seconds.
Can make four at a time per 6-member mirrorset. Limited by number of drives and number of mirrorsets allowed at any one time.	Four Snapshot units allowed per storage array. One per source unit at any one time.

Table B-1: Cloning and Snapshot Comparison (Continued)

Cloning	Snapshot
The Source Unit must have write-back cache disabled.	The Source Unit must have the following characteristics: <ul style="list-style-type: none"> • Less than 512 GB • Write-back cache enabled • Non-transportable • Requires either ACS Version 8.6-1S or 8.6-4P
Can clone an unpartitioned single-disk unit, stripeset, or mirrorset.	The Snapshot Unit must have the following characteristics: <ul style="list-style-type: none"> • Write-back cache enabled • Capacity equal to or greater than the Source Unit • Made of any storage container except write history log containers
Source Unit and Clone both reside on and failover on the same controller.	Source Unit and Snapshot Unit both reside on and failover on the same controller.
Operates in both multi-bus and controller failover modes.	Operates in both multi-bus and controller failover modes.

Cloning Data for Backup

Use the CLONE utility to duplicate data on any unpartitioned single-disk unit, stripeset, mirrorset, or striped mirrorset in preparation for backup. When the cloning operation is done, you can back up the clones rather than the storageset or the single-disk unit, which can continue to service its I/O load. When you are cloning a mirrorset, CLONE does not need to create a temporary mirrorset. Instead, it adds a temporary member to the mirrorset and copies the data to this new member.

The CLONE utility creates a temporary, two-member mirrorset for each member in a single-disk unit or stripeset. Each temporary mirrorset contains one disk drive from the unit you are cloning, and one disk drive to which CLONE copies the data. During the copy operation, the unit remains online and active, so the clones contain the most up to date data.

After the CLONE utility copies the data from the members to the clones, it restores the unit to its original configuration and creates a clone unit you can back up. The CLONE utility uses the steps shown in Figure B-1 to duplicate each member of a unit.

Use the following steps to clone a single-disk unit, stripeset, or mirrorset:

1. Establish a connection to the controller that accesses the unit you want to clone.
2. Start CLONE using the command:

```
RUN CLONE
```
3. When prompted, enter the unit number of the unit you want to clone.
4. When prompted, enter a unit number for the clone unit that CLONE will create.
5. When prompted, indicate how you would like the clone unit to be brought online: either automatically or only after your approval.
6. When prompted, enter the disk drives you want to use for the clone units.
7. Back up the clone unit.

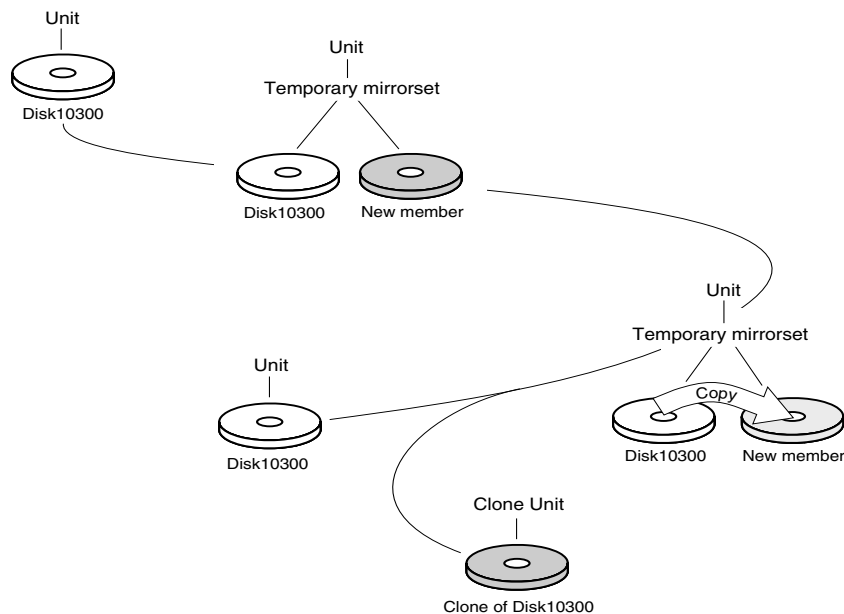

CX05510A

Figure B-1: Steps the CLONE utility follows for duplicating unit members

EXAMPLE: This example shows the commands you would use to clone storage unit D98. The clone command terminates after it creates storage unit D99, a clone or copy of D98. Bold type indicates user entry.

RUN CLONE

CLONE LOCAL PROGRAM INVOKED

UNITS AVAILABLE FOR CLONING: **98**

ENTER UNIT TO CLONE ? **98**

CLONE WILL CREATE A NEW UNIT WHICH IS A COPY OF UNIT 98.

ENTER THE UNIT NUMBER WHICH YOU WANT ASSIGNED TO THE NEW UNIT ? **99**

THE NEW UNIT MAY BE ADDED USING ONE OF THE FOLLOWING METHODS:

1. CLONE WILL PAUSE AFTER ALL MEMBERS HAVE BEEN COPIED. THE USER MUST THEN

PRESS RETURN TO CAUSE THE NEW UNIT TO BE ADDED.

2. AFTER ALL MEMBERS HAVE BEEN COPIED, THE UNIT WILL BE ADDED AUTOMATICALLY.

UNDER WHICH ABOVE METHOD SHOULD THE NEW UNIT BE ADDED[]? 1

DEVICES AVAILABLE FOR CLONE TARGETS:

DISK20200 (SIZE=832317)

DISK20300 (SIZE=832317)

DISK30100 (SIZE=832317)

USE AVAILABLE DEVICE DISK20200(SIZE=832317) FOR MEMBER

DISK10300(SIZE=832317) (Y,N) [Y] ? Y

MIRROR DISK10300 C_MA

SET C_MA NOPOLICY

SET C_MA MEMBERS=2

SET C_MA REPLACE=DISK20200

DEVICES AVAILABLE FOR CLONE TARGETS:

DISK20300 (SIZE=832317)

DISK30100 (SIZE=832317)

USE AVAILABLE DEVICE DISK10400(SIZE=832317) FOR MEMBER DISK(SIZE=832317)

(Y,N) [Y] ? Y

MIRROR DISK10000 C_MB

SET C_MB NOPOLICY

SET C_MB MEMBERS=2

SET C_MB REPLACE=DISK10400

COPY IN PROGRESS FOR EACH NEW MEMBER. PLEASE BE PATIENT...

.

.

COPY FROM DISK10300 TO DISK20200 IS 100% COMPLETE

COPY FROM DISK10000 TO DISK10400 IS 100% COMPLETE

PRESS RETURN WHEN YOU WANT THE NEW UNIT TO BE CREATED

REDUCE DISK20200 DISK10400

UNMIRROR DISK10300

```
UNMIRROR DISK10000
ADD MIRRORSET C_MA   DISK20200
ADD MIRRORSET C_MB   DISK10400
ADD STRIPESET C_ST1  C_MA C_MB
INIT C_ST1   NODESTROY
ADD UNIT D99 C_ST1
D99 HAS BEEN CREATED. IT IS A CLONE OF D98.
CLONE - NORMAL TERMINATION
```

Snapshot

With snapshot, the contents of a Source Unit are frozen in time and presented to the host as a second unit, the *snapshot*. The Snapshot Unit (Figure B–2) preserves the original data (from the time of the snapshot) while allowing writes to the Source Unit to continue. A temporary volume (the Snapshot Unit) is created and used to store the original data that has been overwritten on the Source Unit since the time of the snapshot.

Using a cache bitmap, reads are directed to the Source Unit or the Snapshot Unit.

If no data has been written to the Source Unit since the time of the snapshot, data is then read from the Source Unit.

If data has been written to the Source Unit, then data is read from the Snapshot Unit.

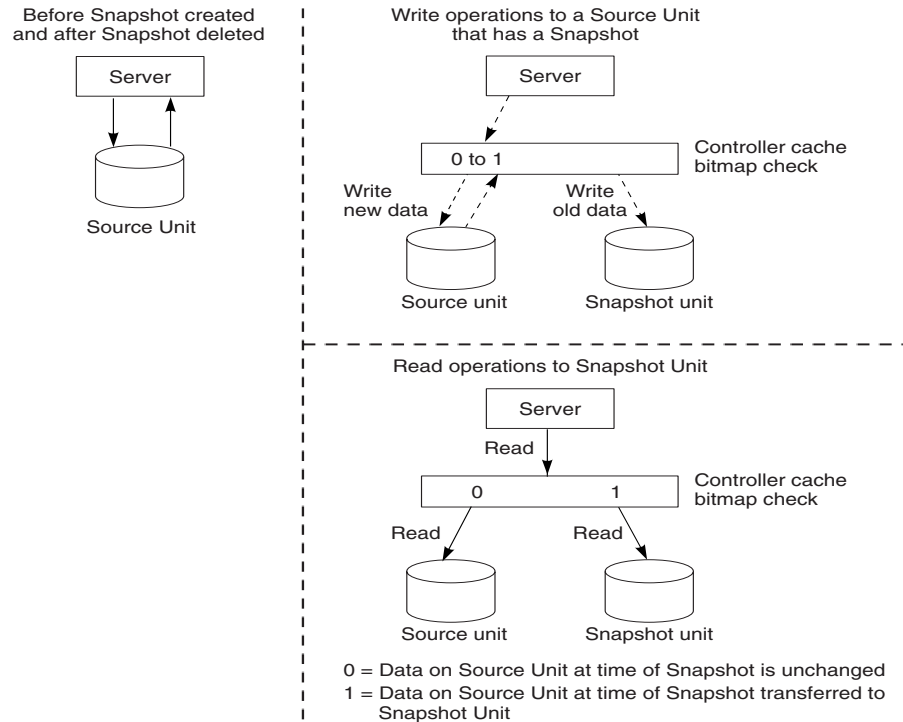

CX07300A

Figure B-2: Snapshot unit

Snapshot Command

NOTE: This command is operational only in controller software versions 8.6S and 8.6P and is operational only if both controllers have 512 MB mirrored cache.

This command creates and names a Snapshot Unit. A Snapshot Unit is one that reflects the contents of another unit at a specific time (the instant the ADD SNAPSHOT_UNITS command is entered). The Snapshot Unit can then be presented to the host. The Snapshot Unit remains until it is deleted (DELETE command).

Syntax

```
ADD SNAPSHOT_UNITS snapshot-unit storage-set source-unit
```

Parameters

The following parameters are required for the ADD SNAPSHOT_UNITS command:

- Snapshot Unit
- Storageset
- Source Unit

When the ADD SNAPSHOT_UNITS command is entered, *storageset* becomes *snapshot-unit* and archives the current contents of *source-unit* at that instant.

These parameters are described in the paragraphs that follow.

snapshot-unit

The unit number assigned to the Snapshot Unit. The unit number must start with a letter (A through Z) and may consist of a maximum of nine characters, including letters A through Z, numerals 0 through 9, periods (.), dashes (-), and underscores (_).

NOTE: If you use scripting to automate failover and failback operations, do not use dashes (hyphens) as separators in your naming convention—use underscores instead. Dashes are not allowed by the Perl scripting language.

The Snapshot Unit is created with all host access disabled by default. Issue a SET command to set up host access.

The Snapshot Unit is created on the same controller as the Source Unit and must remain there.

storageset

Identifies the storageset that becomes the Snapshot Unit. The storageset must:

- Have a capacity equal to or greater than the Source Unit
- Be initialized
- Not be a partition or a concatset

Source Unit

The unit whose contents is frozen in time and preserved on the Snapshot Unit. The Source Unit must:

- Be less than 512 GB
- Have write-back cache enabled
- Be non-transportable

Switches

There are no switches associated with this command.

Example

To create unit D4 (Snapshot Unit), which consists of storageset RAID2, and which becomes a point-in-time snapshot of unit D1 (Source Unit), enter:

```
ADD SNAPSHOT_UNITS D4 raid2 D1
```

Upgrading to ACS Version 8.6-4P Software

Array Controller Software (ACS) Version 8.6-4P implements the DRM feature, which can be upgraded using either a rolling or a shutdown upgrade method. These upgrade methods apply only to dual-redundant controller configurations.

IMPORTANT: The rolling upgrade procedure is not currently supported for Microsoft Windows NT, Microsoft Windows 2000, and IBM AIX platforms. The shutdown upgrade procedure must be used for these platforms.

The rolling upgrade procedure is also not supported for ACS versions prior to Version 8.5 (Version 8.4 to Version 8.5, for example).

Rolling Upgrade Procedure for 8.6-4P

The ACS Version 8.6-4P rolling upgrade from ACS Version 8.5 procedure allows the disk to be accessible during the upgrade process with minimal disruption. Specific controllers are referred to as Controller A or Controller B during the procedure. For clarity, the CLI prompts illustrated in the procedure use *HSGA*> and *HSGB*> to indicate the controller used.

IMPORTANT: The steps in this procedure *must* be followed exactly for the upgrade procedure to work properly. This procedure takes 10 to 20 minutes per site, depending on the complexity of the configuration. The units involved are briefly unavailable twice during the procedures for 10 to 20 seconds in step 11 and step 13.

NOTE: In the procedures that follow, initiator site procedure steps are marked with an initiator symbol, ▶. Target site procedures are marked with a target symbol, ⊙.

NOTE: The rolling upgrade procedure upgrades the initiator site controllers to a specific point and then fully upgrades the target site controllers before finalizing the upgrade for the initiator site controllers.

Initiator Site Upgrade Procedure

Begin the rolling upgrade by executing the following procedure on the initiator site controllers.

- ▶ 1. Connect a PC or terminal to the maintenance port of Controller A at the initiator site. If you cannot find the ACS Version 8.5 configuration, perform the process in Appendix A now.

- ▶ 2. Delete any snapshot units by performing the following steps:

- a. Identify all snapshot units:

```
HSGA> SHOW UNITS FULL
```

- b. Record the configuration for each snapshot unit for later restoration.

- c. Delete all snapshot units individually with the following command:

```
HSGA> DELETE snapshot-unit-name
```

- ▶ 3. Verify that all snapshot units are deleted:

```
HSGA> SHOW UNITS FULL
```

IMPORTANT: If any snapshot unit remains, repeat step 2.

- ▶ 4. Identify and record the current CACHE_FLUSH_TIMER value:

```
HSGA> SHOW THIS_CONTROLLER
```

The following text is only a portion of the resulting display:

Cache:

256 megabyte write cache, version 0022

Cache is GOOD

No unflushed data in cache

CACHE_FLUSH_TIMER=DEFAULT (10 seconds)

NOTE: The CACHE_FLUSH_TIMER value is displayed in the caching parameters section. This parameter is modified during the procedure and must be restored later.

- ▶ 5. For each unit, identify and record the unit WRITEBACK_CACHE characteristics by issuing the following command:

```
HSGA> SHOW UNITS FULL
```

NOTE: The unit WRITEBACK_CACHE characteristics are modified during the upgrade procedure and must be restored later.

- ▶ 6. Set the `CACHE_FLUSH_TIMER` to 1 second to minimize the flush time:

```
HSGA> SET THIS_CONTROLLER CACHE_FLUSH_TIMER=1
HSGA> SET OTHER_CONTROLLER CACHE_FLUSH_TIMER=1
```

- ▶ 7. Disable writeback caching on all units (to help minimize failover time) by issuing the following command as required for each unit:

```
HSGA> SET unit-name NOWRITEBACK_CACHE
```

- ▶ 8. Determine whether all data has been flushed from the cache module:

```
HSGA> SHOW THIS_CONTROLLER
```

The following text is only a portion of the resulting display:

Cache:

```
256 megabyte write cache, version 0022
Cache is GOOD
No unflushed data in cache
CACHE_FLUSH_TIMER=1 SECOND
```

IMPORTANT: Repeat this step on both controllers (`THIS_CONTROLLER` and `OTHER_CONTROLLER`) until no unflushed data remains in either cache module memory. If unwritten data is present after 15 minutes, verify that `WRITEBACK_CACHE` is disabled on all units by issuing the `SHOW UNITS FULL` command. For any units with `WRITEBACK_CACHE` enabled, return to step 7 and proceed.

- ▶ 9. Shut down Controller B:

```
HSGA> SHUTDOWN OTHER_CONTROLLER
```

IMPORTANT: Disregard any messages about misconfigured controllers or failover status.

NOTE: After Controller B shuts down, the **reset** button and the first three LEDs turn on (see Figure C-1). Proceed only after the **reset** button stops flashing and remains on.

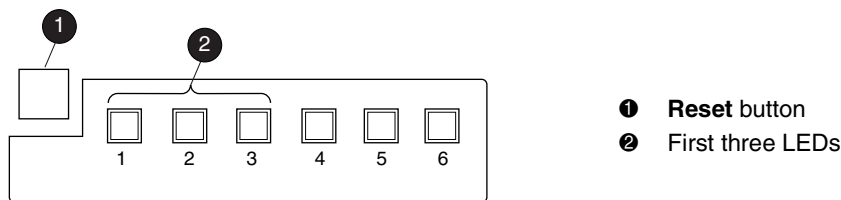

CXO6991A

Figure C-1: Controller reset button and first three LEDs

- ▶ 10. Verify that all units failed over to Controller A:

```
HSGA> SHOW UNITS FULL
```

The following text is only a portion of the resulting display:

State:

ONLINE to this controller
Not reserved

- ▶ 11. Upgrade the software on Controller B by performing the following steps:

IMPORTANT: After this step has been performed, the previous ACS version cannot be restored to this subsystem without performing the downgrade process, which should be performed only by Compaq authorized service personnel.

- a. Remove the program card ESD cover from Controller B.
- b. While pressing and holding the controller reset button, eject the old program card.
- c. After ejecting the program card, release the reset button.
- d. While pressing and holding the controller reset button, insert the new program card.
- e. After the card is fully inserted, release the button. Controller B restarts.

NOTE: A controller restart can take as long as 60 seconds and is indicated by the temporary cycling of the port LEDs and a flashing reset button. Disregard messages about misconfigured controllers or failover status. When controller B has restarted, it automatically shuts down Controller A.

- f. Install the program card ESD cover on Controller B.

- ▶ 12. Verify that Controller B completed initialization:

- a. Connect the PC or terminal to the maintenance port of Controller B.
- b. Make sure that the CLI prompt for Controller B appears.

IMPORTANT: Wait for the CLI prompt before proceeding.

- c. Verify that Controller A is shut down: the reset button and the first three LEDs turn on (see Figure C-1 on page C-3). Proceed only after the reset button stops flashing and remains on.

- ▶ 13. Upgrade the software on Controller A by performing the following steps:
- a. Remove the program card ESD cover from Controller A.
 - b. While pressing and holding the controller reset button, eject the old program card.
 - c. After ejecting the program card, release the reset button.
 - d. While pressing and holding the controller reset button, insert the new program card.
 - e. After the card is fully inserted, release the button. Controller A restarts.
- NOTE:** A controller restart can take as long as 60 seconds and is indicated by the temporary cycling of the port LEDs and a flashing reset button. Disregard messages about misconfigured controllers or failover status.
- f. Install the program card ESD cover on Controller A.



CAUTION: Stop upgrading the initiator site controllers at this point and proceed to upgrade the target site controllers. Failure to upgrade the target site controllers at this point could cause the initiator and target site controllers to crash and prevent the host from accessing data storage in these subsystems.

The initiator site upgrade procedure continues on page C-9 after the target site upgrade procedure.

Continue the rolling upgrade by executing the following procedure on the target site controllers.

Target Site Upgrade Procedure

NOTE: During the target site upgrade, one of the initiator site controllers could restart with an instance code of 0xE096980. This potential restart is expected; disregard the associated instance code.

- ① 1. Connect a PC or terminal to the maintenance port of Controller A at the target site.
- ① 2. Delete any snapshot units by performing the following steps:
 - a. Identify all snapshot units:

```
HSGA> SHOW UNITS FULL
```
 - b. Record the configuration for each snapshot unit for restoration in step 16.

- c. Delete all snapshot units individually with the following command:

```
HSGA> DELETE snapshot-unit-name
```

3. Verify that all snapshot units are deleted:

```
HSGA> SHOW UNITS FULL
```

IMPORTANT: If any snapshot unit remains, repeat step 2.

4. Identify and record the current CACHE_FLUSH_TIMER value:

```
HSGA> SHOW THIS_CONTROLLER
```

The following text is only a portion of the resulting display:

Cache:

256 megabyte write cache, version 0022

Cache is GOOD

No unflushed data in cache

CACHE_FLUSH_TIMER=DEFAULT (10 seconds)

NOTE: The CACHE_FLUSH_TIMER value is displayed in the caching parameters section. This parameter is modified during the procedure and must be restored in step 14.

5. For each unit, identify and record the unit WRITEBACK_CACHE characteristics:

```
HSGA> SHOW UNITS FULL
```

NOTE: The unit WRITEBACK_CACHE characteristics are modified during the upgrade procedure and must be restored in step 15.

6. Set the CACHE_FLUSH_TIMER to 1 second with the following commands:

```
HSGA> SET THIS_CONTROLLER CACHE_FLUSH_TIMER=1  
HSGA> SET OTHER_CONTROLLER CACHE_FLUSH_TIMER=1
```

7. Disable writeback caching on all units to help minimize failover time. Issue the following command as required for each unit:

```
HSGA> SET unit-name NOWRITEBACK_CACHE
```

8. Determine whether all data has been flushed from the cache module:

```
HSGA> SHOW THIS_CONTROLLER
```

The following text is only a portion of the resulting display:

Cache:

```
256 megabyte write cache, version 0022
Cache is GOOD
No unflushed data in cache
CACHE_FLUSH_TIMER=1 SECOND
```

IMPORTANT: Repeat this step on both controllers (THIS_CONTROLLER and OTHER_CONTROLLER) until no unflushed data remains in either cache module memory. If unwritten data is present after 15 minutes, verify that WRITEBACK_CACHE was disabled on all units by issuing the SHOW UNITS FULL command. For any units with WRITEBACK_CACHE enabled, return to step 7 and proceed from there.

9. Shut down Controller B:

```
HSGA> SHUTDOWN OTHER_CONTROLLER
```

IMPORTANT: Disregard any messages about misconfigured controllers or failover status.

NOTE: After Controller B shuts down, the reset button and the first three LEDs turn on (see Figure C-1 on page C-3). Proceed only after the reset button stops flashing and remains on.

10. Verify that all units failed over to Controller A by issuing the following command to show the status of each unit:

```
HSGA> SHOW UNITS FULL
```

The following text is only a portion of the resulting display:

State:

```
ONLINE to this controller
Not reserved
```

11. Upgrade the software on Controller B by performing the following steps.

IMPORTANT: After this step has been performed, the previous ACS version cannot be restored to this subsystem without performing the downgrade process, which should be performed only by Compaq authorized service personnel.

- a. Remove the program card ESD cover from Controller B.
- b. While pressing and holding the controller reset button, eject the old program card.
- c. After ejecting the program card, release the reset button.

- d. While pressing and holding the controller reset button, insert the new program card.
- e. After the card is fully inserted, release the button. Controller B restarts.

NOTE: A controller restart can take as long as 60 seconds and is indicated by the temporary cycling of the port LEDs and a flashing reset button. Disregard messages about misconfigured controllers or failover status. When controller B has restarted, it automatically shuts down Controller A.

- f. Install the program card ESD cover on Controller B.

⊙ 12. After Controller B restarts, verify that Controller B completed initialization:

- a. Connect the PC or terminal to the maintenance port of Controller B.
- b. Make sure that the CLI prompt for Controller B appears.

IMPORTANT: Wait for the CLI prompt before proceeding.

- c. Verify that controller A is shut down; the reset button and the first three LEDs turn on (see Figure C-1 on page C-3). Proceed only after the reset button stops flashing and remains on.

⊙ 13. Upgrade the software on controller A by performing the following steps:

- a. Remove the program card ESD cover from Controller A.
- b. While pressing and holding the controller reset button, eject the old program card.
- c. After ejecting the program card, release the reset button.
- d. While pressing and holding the controller reset button, insert the new program card.
- e. After the card is fully inserted, release the button. Controller A restarts.

NOTE: A controller restart can take as long as 60 seconds and is indicated by the temporary cycling of the port LEDs and a flashing reset button. Disregard messages about misconfigured controllers or failover status.

- f. Install the program card ESD cover on Controller A.

⊙ 14. After Controller A restarts, restore the `CACHE_FLUSH_TIMER` to the value recorded in step 4 using the following commands:

```
HSGA> SET THIS_CONTROLLER CACHE_FLUSH_TIMER=n
HSGA> SET OTHER_CONTROLLER CACHE_FLUSH_TIMER=n
```

- ① 15. For each unit, restore the `WRITEBACK_CACHE` settings as recorded in step 5:

```
HSGA> SET unit-name WRITEBACK_CACHE
```
- ① 16. Restore all snapshot units removed in step 2.
- ① 17. Disconnect the PC or terminal from the maintenance port of Controller A.

Completion of the Initiator Site Upgrade Procedure

- 1. After Controller A restarts, restore the `CACHE_FLUSH_TIMER` to the value recorded in step 4 on page C-2:

```
HSGA> SET THIS_CONTROLLER CACHE_FLUSH_TIMER=n
HSGA> SET OTHER_CONTROLLER CACHE_FLUSH_TIMER=n
```
- 2. For each unit, restore the `writeback_cache` settings as recorded in step 5 on page C-2:

```
HSGA> SET unit-name WRITEBACK_CACHE
```
- 3. Restore all snapshot units removed in step 2 on page C-2.
- 4. Disconnect the PC or terminal from the maintenance port of Controller A.

This completes the rolling upgrade to ACS Version 8.6-4P software.

Shutdown Upgrade Procedure for 8.6-4P

Specific controllers are referred to as Controller A or Controller B in this procedure. For clarity, the CLI prompts illustrated in this procedure use `HSGA>` and `HSGB>` to indicate which controller (A or B) is used.

IMPORTANT: The steps in this procedure *must* be followed exactly for the upgrade procedure to work properly. This procedure takes 5 to 10 minutes per site. The units involved are unavailable during the upgrade procedure. This procedure is useful when upgrading from ACS Version 8.5F, 8.5S, 8.6F, or 8.6S, because it allows for rewiring of the fabrics into a DRM-supported configuration.

Initiator Site Shutdown Upgrade Procedure

Begin the shutdown upgrade using the following procedure on the initiator site controllers:

- 1. From a host console, stop all host activity to the controllers and dismount the logical units in the subsystem.

- ▶ 2. Connect a PC or terminal to the maintenance port of Controller A at the initiator site.

- ▶ 3. Delete any snapshot units by performing the following steps:

- a. Identify all snapshot units:

```
HSGA> SHOW UNITS FULL
```

- b. Record the configuration for each snapshot unit for later restoration.

- c. Delete all snapshot units individually with the following command:

```
HSGA> DELETE snapshot-unit-name
```

- ▶ 4. Verify that all snapshot units are deleted:

```
HSGA> SHOW UNITS FULL
```

IMPORTANT: If any snapshot unit exists, repeat step 3.

- ▶ 5. Identify and record the current CACHE_FLUSH_TIMER value:

```
HSGA> SHOW THIS_CONTROLLER
```

The following text is only a portion of the resulting display:

Cache:

256 megabyte write cache, version 0022

Cache is GOOD

No unflushed data in cache

CACHE_FLUSH_TIMER=DEFAULT (10 seconds)

NOTE: The CACHE_FLUSH_TIMER value appears in the caching parameters section. This parameter is modified during the procedure and must be restored later.

- ▶ 6. Set the CACHE_FLUSH_TIMER to 1 second to minimize the flush time:

```
HSGA> SET THIS_CONTROLLER CACHE_FLUSH_TIMER=1  
HSGA> SET OTHER_CONTROLLER CACHE_FLUSH_TIMER=1
```

- ▶ 7. Determine whether all data has been flushed from the cache module:

```
HSGA> SHOW THIS_CONTROLLER
```

The following text is only a portion of the resulting display:

Cache:

```
256 megabyte write cache, version 0022
Cache is GOOD
No unflushed data in cache
CACHE_FLUSH_TIMER=1 SECOND
```

IMPORTANT: Repeat step 7 on both controllers (THIS_CONTROLLER and OTHER_CONTROLLER) until no unflushed data remains in either cache module memory.

- ▶ 8. Shut down both controllers:

```
HSGA> SHUTDOWN OTHER_CONTROLLER
HSGA> SHUTDOWN THIS_CONTROLLER
```

NOTE: After the controllers shut down, the reset buttons and the first three LEDs on both controllers turn on (see Figure C-1 on page C-3). This could take several minutes, depending on the amount of data that needs to be flushed from the cache modules. Proceed only after both reset buttons stop flashing and remain on.

- ▶ 9. Upgrade the software on both controllers:

IMPORTANT: After step 9 is performed, the previous ACS version cannot be restored to this subsystem without performing the downgrade process, which should be performed only by Compaq authorized service personnel.

- a. Remove the program card ESD cover from Controller A.
- b. While pressing and holding the controller reset button, eject the old program card.
- c. After ejecting the program card, release the reset button.
- d. Repeat step a through step c for Controller B.

IMPORTANT: In step e and step f, the simultaneous release of the reset buttons is essential to ensure that both controllers are restarted and upgraded simultaneously.

- e. Simultaneously press and hold the reset button on both controllers, and insert a new program card into each controller.
- f. Simultaneously release the reset buttons. Both controllers restart.

NOTE: A controller restart can take as long as 60 seconds and is indicated by the temporary cycling of the port LEDs and a flashing reset button. Disregard messages about misconfigured controllers or failover status.

- g. Install a program card ESD cover on each controller.



CAUTION: Stop upgrading the initiator site controllers at this point and proceed to upgrade the target site controllers. Failure to upgrade the target site controllers at this point could cause the initiator and target site controllers to crash and prevent the host from accessing data stored in these subsystems.

The initiator site shutdown upgrade procedure continues on page C–15 after the target site shutdown upgrade procedure.

Continue the shutdown upgrade procedure by executing the following steps on the target site controllers.

Target Site Shutdown Upgrade Procedure

NOTE: During the target site upgrade, one of the initiator site controllers could restart with an instance code of 0xE096980. This potential restart is expected; disregard the associated instance code.

- ① 1. From a host console, stop all host activity to the controllers and dismount the logical units in the subsystem.
- ① 2. Connect a PC or terminal to the maintenance port of Controller A at the target site.
- ① 3. Delete all snapshot units by performing the following steps:
 - a. Identify all snapshot units:

```
HSGA> SHOW UNITS FULL
```
 - b. Record the configuration for each snapshot unit for restoration in step 11.
 - c. Delete all snapshot units individually:

```
HSGA> DELETE snapshot-unit-name
```
- ① 4. Verify that all snapshot units are deleted by issuing the following command:

```
HSGA> SHOW UNITS FULL
```

IMPORTANT: If any snapshot unit exists, repeat step 3.
- ① 5. Identify and record the current `CACHE_FLUSH_TIMER` value:

```
HSGA> SHOW THIS_CONTROLLER
```

The following text is only a portion of the resulting display:

Cache:

```
256 megabyte write cache, version 0022
Cache is GOOD
No unflushed data in cache
CACHE_FLUSH_TIMER=DEFAULT (10 seconds)
```

NOTE: The CACHE_FLUSH_TIMER value is displayed in the caching parameters section. This parameter is modified during the procedure and must be restored in step 10.

- ⑥ 6. Set the CACHE_FLUSH_TIMER to 1 second:

```
HSGA> SET THIS_CONTROLLER CACHE_FLUSH_TIMER=1
HSGA> SET OTHER_CONTROLLER CACHE_FLUSH_TIMER=1
```

- ⑥ 7. Determine whether all data has been flushed from the cache module by issuing the following command:

```
HSGA> SHOW THIS_CONTROLLER
```

The following text is only a portion of the resulting display:

Cache

```
256 megabyte write cache, version 0022
Cache is GOOD
No unflushed data in cache
CACHE_FLUSH_TIMER=1 SECOND
```

IMPORTANT: Repeat this step on both controllers (THIS_CONTROLLER and OTHER_CONTROLLER) until no unflushed data remains in either cache module memory.

- ⑥ 8. Shut down both controllers:

```
HSGA> SHUTDOWN OTHER_CONTROLLER
HSGA> SHUTDOWN THIS_CONTROLLER
```

NOTE: After the controllers shut down, the reset buttons and the first three LEDs on both controllers turn on (see Figure C-1 on page C-3). This could take up to 15 minutes, depending on the amount of data that needs to be flushed from the cache modules. Proceed only after both reset buttons stop flashing and remain on.

9. Upgrade the software on both controllers:

IMPORTANT: After step 9 is performed, the previous ACS version cannot be restored to this subsystem without performing the downgrade process, which should be performed only by Compaq authorized service personnel.

- a. Remove the program card ESD cover from Controller A.
- b. While pressing and holding the controller reset button, eject the old program card.
- c. After ejecting the program card, release the reset button.
- d. Repeat step a through step c for Controller B.

IMPORTANT: In step e and step f, the simultaneous release of the reset buttons is essential to ensure that both controllers are restarted and upgraded simultaneously.

- e. Simultaneously press and hold the reset buttons on both controllers, and insert a new program card into each controller.
- f. Simultaneously release the reset buttons. Both controllers restart.

NOTE: A controller restart can take as long as 60 seconds and is indicated by the temporary cycling of the port LEDs and a flashing reset button. Disregard messages about misconfigured controllers or failover status.

- g. Install a program card ESD cover on each controller.

10. After the controllers restart, restore the `CACHE_FLUSH_TIMER` to the value recorded in step 5 on page C-10:

```
HSGB> SET THIS_CONTROLLER CACHE_FLUSH_TIMER=n
HSGB> SET OTHER_CONTROLLER CACHE_FLUSH_TIMER=n
```

11. Restore all snapshot units removed in step 3.

12. Mount the logical units on the host.

13. Disconnect the PC or terminal from the maintenance port of Controller A.

Completion of Initiator Site Shutdown Upgrade Procedure

- ▶ 1. After the controllers restart, restore the CACHE_FLUSH_TIMER to the value recorded in step 5 on page C-10:

```
HSGB> SET THIS_CONTROLLER CACHE_FLUSH_TIMER=n  
HSGB> SET OTHER_CONTROLLER CACHE_FLUSH_TIMER=n
```

- ▶ 2. Restore all snapshot units removed in step 3 on page C-12.
- ▶ 3. Mount the logical units on the host.
- ▶ 4. Disconnect the PC or terminal from the maintenance port of Controller A.

This completes the shutdown upgrade to ACS Version 8.6-4P software.

Glossary

This glossary defines terms used in this guide or related to the Data Replication Manager. It is not a comprehensive glossary of computer terms.

ACS

See array controller software.

adapter

A hardware device that converts the protocol and hardware interface of one bus type to another without changing the function of either bus.

AL_PA, ALPA

Arbitrated Loop Physical Address. A two-digit hexadecimal number that expresses a port's physical position on the loop. ALPA numbers are normally not assigned in sequence (that is, position 1 is not ALPA 1, and so on). A table in the Fibre Channel Standard equates the loop position to the default ALPA.

arbitrated loop

A Fibre Channel topology. The basic definition is a ring of ports where the transmit output of one port is attached to the receive input of the next. Each port has a unique loop address and it talks to other ports on the loop by arbitrating for loop access. Loop addresses are assigned by cooperative port intercommunication during loop initialization, which occurs any time the device configuration on the loop is physically changed. PLDA (private loop direct attach), the specific profile implemented by the controller, is a subset of arbitrated loop.

See also PL_DA or PLDA.

array controller

See controller.

array controller software (ACS)

Software that is contained on a removable PCMCIA program card that provides the operating environment for the array controller.

association set

A group of remote copy sets that share common attributes. Members of an association set can be configured to transition to the same state at the same time. An association set:

- Shares the same log unit
- Has its host access removed from all members when one member fails
- Keeps I/O order across all members

CLI commands available are ADD ASSOCIATIONS and SET ASSOCIATIONS.

asynchronous mode

A mode of operation of the remote copy set whereby the write operation provides command completion to the host after the data is safe on the initiating controller, and prior to the completion of the target command.

Asynchronous mode can provide greater performance and faster response time, but the data on all members at any time cannot be assumed to be identical.

See also synchronous mode.

ATM

Asynchronous Transfer Mode. ATM refers to a network or communications technology used in LANs and WANs to enable disparate traffic (data, voice, and video) to be carried over the same Local or Wide Area Network. ATM is the transfer mode of choice for broadband integrated services digital networks (BISDNs). ATM traffic carries information in fixed-size cells.

autospare

A controller feature that automatically replaces a failed disk drive with a working drive. The operator can enable the AUTOSPARE switch for the failedset, causing physically replaced disk drives to be automatically placed into the spareset. Data recovery is outside the scope of autosparing. Also called *autonewspare*.

bad block

A disk drive data block that contains a physical defect.

bad block replacement

A replacement routine that substitutes defect-free disk blocks for those found to have defects. This process takes place in the controller and is transparent to the host.

BBR

See bad block replacement.

block

A stream of data stored on disk or tape media that is transferred and error-checked as a unit. In a disk drive, a block is also called a *sector* (the smallest collection of consecutive bytes addressable on a disk drive). In integrated storage elements, a block contains 512 bytes of data, error codes, flags, and the block address header.

cache

A fast, temporary storage buffer in a controller or computer.

cache memory

A portion of high-speed memory used as an intermediary between a data user and a larger amount of storage. The objective of designing cache into a system is to improve performance by placing the most frequently used data in the highest performance memory.

CBR

Constant Bit Rate. A category of ATM service. This category supports a constant (guaranteed) data rate. CBR supports applications that require a highly predictable transmission rate.

cascaded switch

As applied to the Data Replication Manager, a cascaded switch is one where its output is connected to the input of another switch, which then may in turn be connected to another switch or host or controller.

chunk

A block of data written by the host.

See also block, chunk size.

chunk size

The number of data blocks, assigned by a system administrator, written to the primary RAIDset or stripeset member before the remaining data blocks are written to the next RAIDset or stripeset member.

CLI

Command Line Interface. The CLI is the configuration interface that operates the controller software.

clone

A utility that physically duplicates data on any unpartitioned single-disk unit, stripeset, mirrorset, or striped mirrorset.

command line interface, command line interpreter

See CLI.

connection

As applied to the Data Replication Manager, a connection between two end Fibre Channel ports. An example is the connection between a Host Bus Adapter (by way of the Fibre Channel Switches) and the HSG80 controller.

CLI commands available are ADD CONNECTIONS, SET *connection-name*.

See also link.

container

1. Any entity that is capable of storing data, whether it is a physical device or a group of physical devices.
2. A virtual internal controller structure representing either a single disk or a group of disk drives linked as a storageset. Stripesets and mirrorsets are examples of storageset containers that the controller uses to create units.

controller

A hardware device that uses software to facilitate communications between a host and one or more storage devices organized in an array. The HS-series *StorageWorks* family of controllers are all array controllers.

controller failover

The process that takes place when one controller in a dual-redundant configuration assumes the workload of a failed companion controller. Failover continues until the failed controller is repaired or replaced.

The CLI command is SITE_FAILOVER

See also failback, dual-redundant configuration, *and* planned failover.

copying member

In a mirrorset, a copying member is a container introduced to the mirrorset after the mirrorset has already been in use. None of the blocks can be guaranteed to be the same as other members of the mirrorset. Therefore the *copying* member is made the same by copying all the data from a *normal* member. This is in contrast to *normalization*, where all blocks written since creation are known to be the same.

When all of the blocks on the copying member are the same as those on the normal member, the copying member becomes a normal member. Until it becomes a normal member, the copying member contains undefined data and is not useful for any purpose.

default gateway

The default path that a computer or router uses to forward and route data between two or more networks having different protocols.

device

See node *and* peripheral device.

DILX

Disk InLine eXerciser. A utility that tests and verifies the controller's operation with attached storage devices under a high or low I/O load.

disaster tolerance

As applied to DRM, disaster tolerance provides the ability for rapid recovery of user data from a remote location when a significant event or a disaster occurs at the primary computing site.

See also remote copy sets.

dual-redundant configuration

A storage subsystem configuration consisting of two active controllers operating as a single controller. If one controller fails, the other controller assumes control of the failing controller's devices.

See also controller failover, site failover *and* failback.

ECB

External Cache Battery. The unit that supplies backup power to the cache module when the primary power source fails or is interrupted.

EMU

Environmental Monitoring Unit. A device that provides increased protection against catastrophic failures. Some subsystem enclosures include an EMU, which works with the controller to detect conditions such as failed power supplies, failed blowers, elevated temperatures, and external air sense faults. The EMU also controls certain rack hardware, including alarms, fan speeds, and certain chips.

external cache battery

See ECB.

F_Port

A port in a fabric where an N_Port or NL_Port may attach.

fabric

A network of Fibre Channel switches or hubs and other devices.

failback

The process of restoring data access to the newly-restored controller in a dual-redundant controller configuration. The failback method (full copy or fast-failback) is determined by the enabling of the Logging or Failsafe switches, the selected mode of operation (synchronous or asynchronous), and whether the failover is planned or unplanned.

See also controller failover, site failover, *and* dual-redundant configuration.

failedset

A group of disk drives that have been removed from RAIDsets due to a failure or a manual action. Disk drives in the failedset should be considered defective and should be tested and repaired before being placed back into the spareset or back in their original locations.

failover

See controller failover *and* site failover.

failsafe locked

The failsafe error mode can be enabled by the user to fail any write I/O whenever the target is inaccessible or the initiator unit fails. When either of these conditions occurs, the remote copy set goes into the inoperative (offline) state and the failsafe error mode is “failsafe locked.”

The CLI command SET *remote-copy-set-name* ERROR_MODE=FAILSAFE enables this error mode.

fast-failback

The synchronization of the initiator site with the target during a planned failover of the initiator subsystem.

Write operations are logged to the target site write history log and, during the fast-failback, the initiator site is updated from the write history log.

See also mini-merge, unplanned failover, planned failover, *and* write history logging.

FC-AL, FCAL

Fibre Channel Arbitrated Loop. FC-AL is the overall Fibre Channel topology whose basic definition is a ring of ports where the transmit outputs of one port are attached to the receive input of the next.

FC-ATM

Fibre Channel Asynchronous Transfer Mode (ATM AAL5 over Fibre Channel)

FCC

Federal Communications Commission. The federal agency responsible for establishing standards and approving electronic devices within the United States.

FCC Class A

A certification label that appears on electronic devices that can be used only in a commercial environment within the United States.

FCC Class B

A certification label that appears on electronic devices that can be used in either a home or a commercial environment within the United States.

FCP

Fibre Channel Protocol. The mapping of SCSI-3 operations to Fibre Channel.

FDDI

Fiber Distributed Data Interface. An ANSI standard for 100-megabaud transmission over fiber optic cable.

FD SCSI

The fast, narrow, differential SCSI bus with an 8-bit data transfer rate of 10 megabytes per second.

See FWD SCSI *and* SCSI.

fiber

An optical strand used in fiber optic cable. Spelled *Fibre* when used in “Fibre Channel” protocol.

See also fiber optic cable *and* Fibre Channel.

fiber optic cable

A transmission medium that transmits digital signals in the form of pulses of light. Fiber optic cable is noted for its properties of electrical isolation and resistance to electrostatic contamination.

Fibre Channel

An ANSI standard name given to a low-level protocol for a type of serial transmission. The Fibre Channel specifications define the physical link, the low level protocol, and all other pertinent characteristics.

FL_Port

A port in a fabric where an N_port or an NL_port may be connected.

See N_port, NL_port, *and* F_Port.

See also fabric.

frame

The basic unit of communication using Fibre Channel protocol. Each frame consists of a payload encapsulated in control information. The initiator breaks up the exchange into one or more sequences, which in turn are broken into one or more frames. The responder recombines the frames into sequences and exchanges.

See also initiator.

FWD SCSI

Fast, Wide, Differential Small Computer System Interface. A SCSI bus with a 16-bit data transfer rate of up to 20 megabytes per second.

See also FD SCSI *and* SCSI.

GBIC

Gigabit Interface Converter. Devices inserted into the ports of the Fibre Channel switch that hold the Fibre Channel cables. A GBIC converts fiber optic cable connections to Fibre Channel switch connections.

GLM

Gigabit Link Module, used in short wave multi-mode fiber only. GLMs, as a function of GBIC, are used in Fibre Channel long-distance applications. As applied to the Data Replication Manager, the GLMs provide the ability to increase the fiber optic cable transmission distances from 10 km to 70 km.

hard address

The AL_PA or ALPA that an NL_port attempts to acquire during loop initialization.

heterogeneous host support

Also called *noncooperating host support*. The ability to share storage between two similar (or dissimilar) hosts by way of storage partitioning.

HIPPI-FC

High-performance Parallel Interface over the Fibre Channel. A media-level, point-to-point, 12-channel, full-duplex, electro-optical interface.

hop

One or more connections between two Fibre Channel switches. For example, two switches cascaded are equal to one hop.

ISL

Intersite link or Interswitch link. The abbreviation is context sensitive.

See also multiple intersite links.

initiator

1. A SCSI device that requests an I/O process to be performed by another SCSI device, namely, the SCSI target. The controller is the initiator on the device bus.
2. For subsystems using the disaster tolerance Data Replication Manager solution, the initiator is the site that is the primary source of information. In the event of a system outage, the database would be recovered from the target system.

See also target.

IP address

Internet Protocol Address. TA number that is used as the address specifying a particular computer connected to the internet.

latency

The amount of time required for a transmission to reach its destination.

LBN

Logical Block Number. A volume-relative address of a block on a mass storage device. The blocks that form the volume are labeled sequentially, starting with LBN 0.

L_port

A node or fabric port capable of performing arbitrated loop functions and protocols. The NL_port and the FL_Port are loop-capable ports.

link

A connection between two adjacent Fibre Channel ports, consisting of a transmit fiber and a receive fiber. An example is the connection between the Fibre Channel switch port and the HSG80 controller.

See also connection.

local terminal

A terminal plugged into the EIA-423 maintenance port on the front bezel of the HS array controller. Also called a *maintenance terminal*.

Logical Block Number

See LBN.

logical unit

A physical or virtual device addressable through a target ID number. The logical unit numbers (LUNs) use their target's bus connection to communicate on the SCSI bus.

See also LUN.

Logical Unit Number

See LUN.

LOG_UNIT

A CLI command switch that (when enabled) assigns a single, dedicated log unit for a specific association set. The association set members must all be in the NORMAL error mode (not failsafe).

See also write history logging.

long distance mirroring

Also known as *peer-to-peer remote copy*.

See remote copy sets.

loop

See also arbitrated loop.

loop_ID

A seven-bit value, numbered consecutively from zero to 126-decimal, that represents the 127 legal AL_PA or ALPA values on a loop (not all of the 256 hex values are allowed as AL_PA values per FC-AL).

loop tenancy

The time between two events: when a port wins loop arbitration and when the port returns to a monitoring state.

L_Port

A node or fabric port capable of performing arbitrated loop functions and protocols. NL_Ports and FL_Ports are loop-capable ports.

LUN

Logical Unit Number. A value that identifies a specific logical unit belonging to a SCSI target ID number. A number associated with a physical device unit during a task's I/O operations. Each task in the system must establish its own correspondence between logical unit numbers and physical devices.

mini-merge

As applied to the Data Replication Manager, the data transfers to be made whenever a target becomes inaccessible. This occurs when both links or both target controllers have gone down. The transfers that would have been made are instead logged into the association set's assigned log unit to wait until the remote copy set subsystem comes back online.

See fast-failback, write history logging.

mirroring

The act of creating an exact copy or image of data.

mirrorset

1. A group of storage devices organized as duplicate copies of each other. Mirrorsets provide the highest level of data availability at the highest cost. Another name for RAID 1. Also called *mirrored units* or *mirrored virtual disks*.
2. Two or more physical disks configured to present one highly reliable virtual unit to the host.
3. A virtual disk drive consisting of multiple physical disk drives, each of which contains a complete and independent copy of the entire virtual disk's data.

multiple intersite links

Each intersite link (ILS) is a fiber link between two switches. As applied to Data Replication Manager, increasing bandwidth between switches is handled by adding additional connections between the switches, to a maximum of two connections.

N_port

A port attached to a node for use with point-to-point topology or fabric topology.

See point-to-point connection.

NL_port

A port attached to a node for use in all three Fibre Channel topologies: point-to-point, arbitrated loop, and switched fabric.

network

In data communication, a configuration in which two or more terminals or devices are connected to enable information transfer.

Non-L_Port

A node or fabric port that is not capable of performing arbitrated loop functions and protocols. N_Ports and F_Ports are loop-capable ports.

non-participating mode

A mode within an L_Port that inhibits the port from participating in loop activities. L_Ports in this mode continue to retransmit received transmission words but are not permitted to arbitrate or originate frames. An L_Port in non-participating mode may or may not have an AL_PA.

See also participating mode.

non-RCS LUN

As applied to Data Replication Manager, a logical unit number (LUN) value that identifies a physical device unit, which exists at the local site and does not have a mirror copy at a remote site.

See also remote copy sets *and* LUN.

node

1. In data communications, the point at which one or more functional units connect transmission lines.
2. In Fibre Channel, a device that has at least one N_port or NL_port.

normal member

A mirrorset member that, block-for-block, contains exactly the same data as that on the other members within the mirrorset. Read requests from the host are always satisfied by normal members.

normalizing

A state in which, block-for-block, data written by the host to a mirrorset member is consistent with the data on other normal and normalizing members. The normalizing state exists only after a mirrorset is initialized. Therefore, no customer data is on the mirrorset.

normalizing member

A mirrorset member whose contents are the same as all other normal and normalizing members for data that has been written since the mirrorset was created or since lost cache data was cleared. A normalizing member is created by a normal member when either all of the normal members fail or all of the normal members are removed from the mirrorset.

See also copying member

OC-3

The Optical Carrier that provides high-speed bandwidth at 155.3 megabits per second.

other controller

The controller in a dual-redundant pair that is not connected to the controller serving your current CLI session with a local terminal.

See also this controller *and* local terminal.

participating mode

A mode within an L_port that allows the port to participate in loop activities. A port must have a valid AL_PA or ALPA to be in participating mode.

PCM

Polycenter Console Manager

PCMCIA

Personal Computer Memory Card Industry Association. An international association that promotes a common standard for PC card-based peripherals to be plugged into notebook computers. A PCMCIA card, sometimes called a *PC Card*, is about the size of a credit card. It is used in the HSG80 to load the controller software.

See also program card *and* array controller software.

PCR

Peak Cell Rate. The maximum transmission speed of a virtual connection. PCR is a required parameter for the CBR service category.

peer-to-peer remote copy

See remote copy sets.

peripheral device

Any unit, distinct from the CPU and physical memory, that can provide the system with input or accept any output from it. Terminals, printers, tape drives, and disks are peripheral devices.

planned failover

As applied to the Data Replication Manager, an orderly shutdown of the controllers for installation of new hardware, updating the software, and so on. The host applications are quiesced and all write operations permitted to complete before the shutdown. The controllers must be in synchronous operation mode before starting a planned failover.

See also synchronous mode *and* unplanned failover.

PL_DA, PLDA

Private Loop Direct Attach. PLDA is a Fibre Channel profile, a proper subset of arbitrated loop. The PLDA profile (part of the Fibre Channel Standard), defines a specific way to implement arbitrated loop topology.

See arbitrated loop.

point-to-point connection

A network configuration in which a connection is established between two, and only two, terminal installations. The connection may include switching facilities.

See N_port.

port

In general terms, a port is:

1. A logical channel in a communications system.
2. The hardware and software used to connect a host controller to a communications bus, such as a SCSI bus or serial bus.

With respect to the controller, the port is:

1. The logical route for data in and out of a controller that can contain one or more channels, all of which contain the same type of data.
2. The hardware and software that connect a controller to a SCSI device.

port_name

A 64-bit unique identifier assigned to each Fibre Channel port. The Port_Name is communicated during the logon and port discovery process.

preferred address

The AL_PA that an NL_Port attempts to acquire first during initialization.

private NL_Port

An NL_Port that does not attempt login with the fabric and communicates only with NL_Ports on the same loop.

public NL_Port

An NL_Port that attempts login with the fabric and can observe the rules of either public or private loop behavior. A public NL_Port may communicate with both private and public NL_Ports.

program card

The PCMCIA card containing the controller's operating software.

See also PCMCIA.

PTL

Port-Target-LUN. The controller's method of locating a device on the controller device bus:

- P designates the port (1—6).
- T designates the target ID of the device (1—6 in a non-redundant configuration, or 0—5 in a dual-redundant configuration).
- L designates the LUN of the devices (0—7).

PVA module

Power Verification and Addressing module. The Ultra SCSI RAID enclosure assembly whose primary functions are to:

1. Allow the user to select the enclosure Ultra SCSI bus ID
2. Enable the user to place the subsystem in a standby condition and return it to an operational status
3. Ensure, in conjunction with the associated EMU, that the major Ultra SCSI elements are functioning properly and notify the user and the controller of error or fault conditions

PVC

Permanent Virtual Circuit. PVC is a logical connection manually defined by the network administrator. The PVC is created by specifying the VPI and VCI.

quiesce

To make a bus inactive or dormant. During a device warm swap, the SCSI bus must quiesce.

See also planned failover.

QoS

Quality of Service (in an ATM network). Each virtual connection in an ATM network is set to a service category. The performance of the connection is measured by the established QoS parameters (outlined by the ATM Forum).

Performance issues include data rate, cell loss rate, cell delay, and delay variation (jitter).

Categories of ATM service are:

- Constant Bit Rate (CBR)
- Variable Bit Rate-Real Time (VBR-RT)
- Variable Bit rate-Non-Real Time (VBR-NRT)
- Available Bit Rate (ABR)
- Unspecified Bit Rate (UBR)

See ATM.

RCS

See remote copy sets.

redundancy

The provision of multiple interchangeable components to perform a single function to cope with failures and errors. A RAIDset is considered to be redundant when user data is recorded directly to one member; all of the other members and associated parity are also recorded. If a member is missing from the RAIDset, its data can be regenerated as needed, but the RAIDset is no longer redundant until the missing member is replaced and reconstructed.

remote copy sets

A feature that allows data to be copied (mirrored) from the originating site (initiator) to a remote site (target). The result is a mirror copy of the data (remote copy set) at two disparate sites. Used in disaster tolerant (DT) applications such as the Data Replication Manager.

CLI commands available are `ADD REMOTE_COPY_SETS`, `SET remote-copy-set-name`, `SET controller REMOTE_COPY`.

See also disaster tolerance *and* non-RCS LUN.

remote copy set metadata

Data that describes the remote copy set membership and state. To assist with site failover, this metadata is located in the mirrored write-back cache on the controller where each member resides. Backup copies of the metadata reside in the controller NVRAM at each site. Only the initiator modifies the metadata and ensures all copies are subsequently updated.

replacement policy

The policy specified by a CLI command switch (`SET FAILEDSET` command) indicating whether a failed disk from a mirrorset or RAIDset is to be automatically replaced with a disk from the spareset. The two switch choices are `AUTOSPARE` and `NOAUTOSPARE`.

SCSI

An acronym for Small Computer System Interface:

1. An American National Standards Institute (ANSI) interface standard defining the physical and electrical parameters of a parallel I/O bus used to connect initiators to devices.
2. A processor-independent standard protocol for system-level interfacing between a computer and intelligent devices, including hard drives, floppy disks, CD-ROMs, printers, scanners, and others.

SCSI device

1. A host computer adapter, a peripheral controller, or an intelligent peripheral that can be attached to the SCSI bus.
2. Any physical unit that can communicate on a SCSI bus.

SCSI device ID number

A bit-significant representation of the SCSI address referring to one of the signal lines, numbered 0 through 7 for an 8-bit bus, or 0 through 15 for a 16-bit bus.

SCSI ID number

The representation of the SCSI address that refers to one of the signal lines numbered 0 through 15.

site failover

The process that takes place when storage processing is moved from one pair of controllers to another. All processing is shifted to the target (remote) site. This is possible because all data generated at the initiator site has been replicated at the target site, in readiness for such a situation.

snapshot

A snapshot unit is one that reflects the contents of another unit at a particular time.

See also unit.

storage array

An integrated set of storage devices. Storage arrays can be manipulated as one unit with a single command.

storage unit

The generic term for storagesets, single-disk units, and all other storage devices that are installed in a subsystem and accessed by the host. A storage unit can be any entity that is capable of storing data, whether it is a physical device or a group of physical devices.

storageset

1. A group of devices configured with RAID techniques to operate as a single container.
2. Any collection of containers, such as stripesets, mirrorsets, striped mirrorsets, JBODs, and RAIDsets.

subnet mask

Also called an *address mask*. A subnet is an IP network that can be reached through a single IP address. All the members of the subnet share the mask value. Members of the subnet can then be referenced more easily. A subnetwork is a network that is part of another network, connected through a gateway, bridge, or router.

surviving controller

The controller in a dual-redundant configuration pair that serves its companion's devices when the companion controller fails.

SWCC

Storage Works Command Console

synchronous mode

A mode of operation of the remote copy set whereby the data is written simultaneously to the cache of the initiator subsystem and the cache of the target subsystem. The I/O completion status is not sent until all members of the remote copy set are updated.

See also asynchronous mode.

target

A SCSI device that performs an operation requested by another SCSI device, namely the SCSI initiator. The target number is determined by the device's address on its SCSI bus.

For subsystems using the disaster-tolerant Data Replication Manager solution, data processing occurs at the initiator site and the data is replicated or mirrored to the target site. In the event of a system outage, the database is recovered from the target system.

See also initiator.

this controller

The controller that is serving the current CLI session through a local or remote terminal.

See also other controller.

UBR

Unspecified Bit Rate. The UBR is a category of ATM service that supports connections that have no specified performance requirements.

ULP

Upper Layer Protocol.

See also ULP process.

ULP process

A function executing within a Fibre Channel node that conforms to the Upper Layer Protocol (ULP) requirements when interacting with other ULP processes.

UltraNet Wizard

Another term for the Fibre Channel-to-ATM Configuration Wizard. This wizard is an UltraNet application that allows the designation of the default configuration settings for Fibre-Channel-ATM on the Open Systems Gateway.

unit

A container made accessible to a host. A unit may be created from a single disk drive or tape drive. A unit may also be created from a more complex container, such as a RAIDset. The controller supports a maximum of eight units on each target.

unplanned failover

As applied to the Data Replication Manager, recovery from an unplanned outage of the controllers. This may occur when the site communication is lost or it may be due to some other failure whereby remote copy sets cannot be implemented. The controllers do not perform an orderly shutdown.

See also planned failover.

VCI

Virtual Channel Identifier. The VCI is the field of the cell header that stores the virtual channel address.

VPI

Virtual Path Identifier. The field of the cell header that stores the virtual path address.

World Wide Name, World wide ID

Also known by the acronyms *WWID* and *WWN*. A unique 64-bit number assigned to a subsystem by the Institute of Electrical and Electronics Engineers (IEEE) and set by manufacturing prior to shipping. This name is referred to as the node ID within the CLI.

write history logging

As applied to the Data Replication Manager, the use of a log unit to log a history of write commands and data from the host. Write history logging is used for mini-merge and fast-failback.

See mini-merge *and* fast-failback.

WTI Switch

Western Telematic Switch that must be installed to set up and service the ATM gateway. The WTI switch is a 16-port serial switch that configures or services the OSG unit locally or remotely.

zone

A set of devices that access one another. All devices connected to a fabric may be configured into one or more zones. Devices that are in the same zone can see each other; devices that are in different zones cannot.

zone alias

A C-style name for one or more port numbers or World Wide Names (for example, the named host could be used as an alias for 10:00:00:60:69:00:00:8a). Zone aliases simplify the entry of repetitive port numbers or World Wide Names.

zone configuration

A set of zones. Zoning may be disabled at any time or one zone configuration may be in effect. When a zone configuration is in effect, all zones that are members of that configuration are in effect. You select which zone configuration is currently in effect.

zoning

As applied to the Data Replication Manager, an optional, licensed feature of the SilkWorm switch that allows a finer segmentation of Storage Area Networks (SANs) by allowing ports or WWN addresses to confine access to devices that are in a common zone.

Index

A

- add associations command 2–8, 4–74
- add mirrorset command 4–73
- add remote copy set command 4–69, 4–70, 4–71
- add snapshot units command B–7
- add unit command 4–16, 4–63, 4–73
- AIX
 - configuring SWCC agent at initiator site 4–95
 - configuring SWCC agent at target site 4–43
 - connecting host to SAN at initiator site 4–93
 - connecting host to SAN at target site 4–41
 - disabling access to hosts at target site 4–42
 - enabling access to hosts at initiator site 4–95
 - installing HBAs at initiator site 4–86
 - installing HBAs at target site 4–33
 - installing platform kit at target site 4–33, 4–86
 - installing Secure Path Fibre Channel HBA
 - device driver at target site 4–33, 4–86
 - renaming host connections at initiator site 4–94
 - renaming host connections at target site 4–41
 - setting up at initiator site 4–86
 - setting up at target site 4–33
 - updating switch zones at initiator site 4–94
 - updating switch zones at target site 4–42
 - verifying disks at initiator site 4–95
 - verifying disks at target site 4–42
- aliCreate command 8–20, 8–23
- applications names, convention defined xix
- assigning World Wide Name 4–10
- association sets

- characteristics of 2–6
- creating at initiator site 4–72, 4–74
- definition 2–6
- FAIL_ALL switch 2–7
- location on initiator controller pair 2–7
- LOG_UNIT switch 2–11
- ORDER_ALL switch 2–11
- re-creation upon site failover 2–8
- asynchronous operation mode 2–3
- audience xvi
- authorized reseller, Compaq xxii

B

- BA370 enclosure 1–3
- button names, convention defined xix

C

- cabling
 - between controllers and Fibre Channel switches 4–67
 - from initiator to target site 4–68
 - the initiator site 4–65 to 4–67
 - the target site 4–19 to 4–22
- cascaded switches
 - configurations 3–7
- caution, symbol and definition xix
- cfgAdd command 8–24
- cfgCreate command 8–15, 8–16
- cfgEnable command 8–15, 8–16, 8–24, 8–26, 8–29
- cfgShow command 8–25, 8–27
- clone B–2
- clone utility B–2
- clone utility, backup B–2

- cloning and snapshot comparison B-1
- cloning defined B-1
- cluster server, installing for Windows 4-110
- cluster services, installing for NetWare 4-110
- command names, convention defined xix
- commands
 - add associations 2-8, 4-74
 - add mirrorset 4-73
 - add remote copy set 4-69, 4-70, 4-71
 - add snapshot units B-7
 - add unit 4-16, 4-63, 4-73
 - aliCreate 8-20, 8-23
 - cfgAdd 8-24
 - cfgCreate 8-15, 8-16
 - cfgEnable 8-15, 8-16, 8-24, 8-26, 8-29
 - cfgShow 8-25, 8-27
 - delete B-7, C-2, C-5, C-9
 - initialize 4-73
 - rename 4-26, 4-78, 4-81, 4-98, 4-103, 4-107
 - restart controller 4-14, 4-18, 4-61, 4-64
 - scan for new devices 4-104
 - set alloclass 4-12
 - set cache flush timer C-2
 - set controller identifier 4-12
 - set controller mirrored cache 4-13, 4-60
 - set controller node 4-57
 - set controller port topology 4-14, 4-61
 - set controller prompt 4-60
 - set controller remote copy 4-15, 4-62
 - set disable 4-42
 - set disable access path 4-17, 4-63, 4-74
 - set enable access path 4-71, 4-79, 4-95, 4-104
 - set error mode 4-72
 - set fail all 4-76
 - set identifier 4-59
 - set log unit 4-75
 - set maximum cached transfer size 4-17
 - set multibus failover copy 4-58, 7-28
 - set nowriteback cache 4-74, C-2, C-6
 - set operating system to AIX 4-41
 - set operating system to NetWare 4-50, 4-103
 - set operating system to OpenVMS 4-78
 - set operating system to Solaris 4-53, 4-107
 - set operating system to Tru64 UNIX 4-29, 4-81
 - set operating system to Windows 4-46, 4-99
 - set order all 4-76
 - set preferred path 4-18, 4-64
 - set SCSI mode 4-59
 - set unit identifier 4-17, 4-63
 - set writeback cache C-9
 - show associations A-2
 - show connections 4-26, 4-28, 4-29, 4-42, A-2
 - show remote 7-26
 - show remote copy A-2
 - show units 4-73
 - shutdown controller 7-28, C-3, C-10, C-13
 - snapshot B-7
 - switch version 7-12
 - switchShow 7-12, 7-14, 7-16, 7-18
 - zoneAdd 8-29
 - zoneCreate 8-15, 8-23
- Compaq
 - authorized reseller xxii
 - technical support xxi
 - website xxii, 3-3, 4-43, 4-44, 4-96
- components, software required for disaster tolerance 1-14
- configurations
 - heterogeneous 8-16
 - homogeneous 8-3
 - multiple intersite links 3-10
- configuring
 - controllers at initiator site 4-55 to 4-62
 - controllers at target site 4-8 to 4-16
 - host at initiator site 4-76 to 4-109
 - host at target site 4-23 to 4-55
 - storage at initiator site 4-63 to 4-65
 - storage at target site 4-16 to 4-19

connections
 defined 3–6
 host-to-switch 3–4
 switch-to-controller 3–4
 controller replacement 7–27 to 7–28
 controllers, configuring for multiple-bus failover 4–11

conventions
 application names, defined xix
 button names, defined xix
 command names, defined xix
 dialog box names, defined xix
 document xix
 file names, defined xix
 keyboard keys, defined xix
 menu items, defined xix
 menu sequences, defined xix
 system responses, defined xix
 user input, defined xix
 variables xix
 website addresses xix

creating zone names 8–14, 8–23

D

data security 8–2
 delete command B–7, C–2, C–5, C–9
 dialog box names, convention defined xix
 document
 conventions xix
 documentation, related xvi

DRM

 basic configuration 4–2
 command line interface (CLI) to 4–6
 components 1–8
 enabling at initiator site 4–62
 operating restrictions 4–3

E

electrical shock hazard, symbol and definition xx
 EMA12000 rack 1–3, 1–10
 EMA16000 rack 1–3
 enclosure, BA370 1–3
 environmental monitoring unit (EMU) 1–7

equipment symbols xx
 error mode
 failsafe 2–6
 normal switch setting for 2–6
 switch 2–5

ESA12000 rack 1–3, 1–10

Ethernet 3–3

excessive weight, symbol and definition xx

F

fabric topology, setting 4–14

failback 2–13

failover

 planned 2–12
 unplanned 2–12

failsafe, setting at initiator site 4–72

fiber optic cable

 connecting between target controllers and switches 4–19
 host-to-switch connections 3–4
 multi-mode 1–9
 setting up 3–4
 single-mode 1–10
 switch-to-controller connections 3–5

Fibre Channel

 installing software for Windows at initiator site 4–96
 installing software for Windows at target site 4–44
 setting up switch 3–3
 switch-to-controller connection 3–5

file names, convention defined xix

fully-redundant power 1–11

G

GBIC

 fiber optic cable for 3–5
 inserting short wave 4–19
 long wave or very long distance 4–21, 4–67
 short-wave 1–9, 4–66

getting help xxi

 Compaq technical support xxi

 Compaq website xxii

H

- hardware, required components 1–3
- HBAs
 - installing driver for NetWare at initiator site 4–100
 - installing driver for NetWare at target site 4–47
 - installing driver for Tru64 UNIX at initiator site 4–80
 - installing driver for Tru64 UNIX at target site 4–27
 - installing driver for Windows at initiator site 4–96
 - installing driver for Windows at target site 4–44
 - installing for AIX at initiator site 4–86
 - installing for AIX at target site 4–33
 - installing for NetWare at initiator site 4–100
 - installing for NetWare at target site 4–47
 - installing for OpenVMS at initiator site 4–76
 - installing for OpenVMS at target site 4–23
 - installing for Solaris at initiator site 4–105
 - installing for Solaris at target site 4–51
 - installing for Tru64 UNIX at initiator site 4–79
 - installing for Tru64 UNIX at target site 4–27
 - installing for Windows at initiator site 4–96
 - installing for Windows at target site 4–43
 - overview 1–11
 - requirements 3–2
 - World Wide Name 4–8, 4–45
- help, obtaining xxi
- heterogeneous configuration 8–16
- homogeneous configuration 8–3
- hop rules 3–7
- host connections, limit of 96 8–2
- hosts
 - host-to-switch connection 3–4
 - preparation 3–1
- hot surface, symbol and definition xx

I

- important, defined xix
- initialize command 4–73
- initiator site
 - assigning write history log units at 4–74
 - cabling of 4–65
 - changing prompts at 4–60
 - configuring controllers 4–55 to 4–62
 - configuring storage at 4–63 to 4–65
 - configuring SWCC agent for AIX 4–95
 - configuring SWCC agent for Solaris 4–109
 - configuring the host at 4–76 to 4–109
 - connecting host to SAN for AIX 4–93
 - connecting host to SAN for NetWare 4–102
 - connecting host to SAN for OpenVMS 4–77
 - connecting host to SAN for Solaris 4–106
 - connecting host to SAN for Tru64 UNIX 4–80
 - connecting host to SAN for Windows 4–97
 - creating association sets at 4–72, 4–74
 - creating remote copy sets at 4–69
 - creating storage units 4–63
 - creating switch zones at 4–69
 - creating write history log units at 4–72
 - enabling access to hosts for AIX 4–95
 - enabling access to hosts for NetWare 4–104
 - enabling access to hosts for OpenVMS 4–79
 - enabling access to hosts for Solaris 4–108
 - enabling access to hosts for Tru64 UNIX 4–82
- installing Fibre Channel software for Windows 4–96
- installing HBA driver for NetWare 4–100
- installing HBA driver for Tru64 UNIX 4–80
- installing HBA driver for Windows 4–96
- installing HBAs for AIX 4–86
- installing HBAs for NetWare 4–100
- installing HBAs for OpenVMS 4–76
- installing HBAs for Solaris 4–105
- installing HBAs for Tru64 UNIX 4–79
- installing HBAs for Windows 4–96

- installing multipath software for Windows 4-97
- installing Secure Path agent for NetWare 4-100
- installing Secure Path for Solaris 4-109
- installing Secure Path manager for NetWare 4-101
- installing Solaris platform kit 4-106
- installing SWCC for NetWare 4-101
- installing SWCC for OpenVMS 4-77
- installing SWCC for Tru64 UNIX 4-80
- installing SWCC for Windows 4-97
- renaming host connections for AIX 4-94
- renaming host connections for NetWare 4-103
- renaming host connections for OpenVMS 4-78
- renaming host connections for Solaris 4-107
- renaming host connections for Tru64 UNIX 4-81
- renaming host connections for Windows 4-98
- reverifying disks for Solaris 4-109
- rolling upgrade procedure C-1
- setting failsafe at 4-72
- setting up AIX at 4-86
- setting up NetWare at 4-100
- setting up OpenVMS at 4-76
- setting up Solaris at 4-105
- setting up Tru64 UNIX at 4-79
- setting up Windows at 4-96
- shutdown upgrade procedure C-9
- Tru64 UNIX multipath software support 4-80
- updating switch zones for AIX 4-94
- updating switch zones for NetWare 4-104
- updating switch zones for OpenVMS 4-79
- updating switch zones for Solaris 4-108
- updating switch zones for Tru64 UNIX 4-82
- updating switch zones for Windows 4-99
- verifying disks for AIX 4-95
- verifying disks for Solaris 4-108
- intersite links
 - multiple 3-10
- K**
- keyboard keys, convention defined xix
- L**
- LUNs
 - configuring at target site 4-16
 - maximum number of non-RCS 4-5
- M**
- MA8000 modular configuration 1-10
- menu
 - items, convention defined xix
 - sequences, convention defined xix
- mirrored write-back cache 4-13
- multi-mode fiber optic cable 1-9
- multipath software
 - installing for Windows at initiator site 4-97
 - installing for Windows at target site 4-44
 - support for Tru64 UNIX at target site 4-27
- multiple bus failover 4-11, 7-11
- multiple e-port connectivity software option 3-10
- multiple intersite links 3-10
- multiple power source, symbol and definition xx
- N**
- NetWare
 - connecting host to SAN at initiator site 4-102
 - connecting host to SAN at target site 4-49
 - enabling access to hosts at initiator site 4-104
 - installing cluster services 4-110
 - installing HBA driver at initiator site 4-100
 - installing HBA driver at target site 4-47
 - installing HBAs at initiator site 4-100
 - installing HBAs at target site 4-47
 - installing Secure Path agent at initiator site 4-100
 - installing Secure Path agent at target site 4-47
 - installing Secure Path manager at initiator site 4-101

- installing Secure Path manager at target site 4-48
- installing SWCC at initiator site 4-101
- installing SWCC at target site 4-49
- renaming host connections at initiator site 4-103
- renaming host connections at target site 4-49
- setting up at initiator site 4-100
- setting up at target site 4-47
- updating switch zones at initiator site 4-104
- updating switch zones at target site 4-50
- network interface connection, symbol and definition xx
- non-remote copy set LUNS, maximum number 4-5
- non-remote copy sets 2-2
- note, defined xix

O

OpenVMS

- connecting host to SAN at initiator site 4-77
- connecting host to SAN at target site 4-24
- enabling access to hosts at initiator site 4-79
- installing HBAs at initiator site 4-76
- installing HBAs at target site 4-23
- installing SWCC at initiator site 4-77
- installing SWCC at target site 4-24
- renaming host connections at initiator site 4-78
- renaming host connections at target site 4-25
- setting up at initiator site 4-76
- setting up at target site 4-23
- updating switch zones at initiator site 4-79
- updating switch zones at target site 4-26

operation modes

- asynchronous 2-3
- considerations when designing 2-3
- synchronous 2-2

outstanding I/O settings

- asynchronous 2-4
- default 2-4
- high outstanding I/O values 2-5

- low outstanding I/O values 2-5
- outstanding write operations 2-5
- synchronous 2-4

P

- parameters for add snapshot unit command B-8
- peer-to-peer remote copy function 2-1
- planned failover 2-12
- power distribution unit (PDU) 1-10, 4-8
- power, fully-redundant 1-11
- prompts
 - changing at initiator site 4-60
 - changing at target site 4-13

R

- RA8000 rack 1-10
- rack stability, warning xxi
- racks
 - EMA12000 1-10
 - EMA16000 1-3
 - ESA12000 1-3, 1-10
 - RA8000 1-10
- related documentation xvi
- remote copy function, peer-to-peer 2-1
- remote copy sets
 - creating at initiator site 4-69
 - overview 2-2
 - resume switch 2-5
 - suspend switch 2-5
- rename command 4-26, 4-78, 4-81, 4-98, 4-103, 4-107
- replicating storage units, cloning data for backup B-2
- resource partitioning 8-2
- restart controller command 4-14, 4-18, 4-61, 4-64
- restrictions
 - Management Appliance 1-16
 - StorageWorks Command Console 1-16
- rolling upgrade procedure C-1 to C-9

S

- scan for new devices command 4-104
- Secure Path
 - installing agent for NetWare at initiator site 4-100
 - installing agent for NetWare at target site 4-47
 - installing Fibre Channel HBA device driver for AIX at target site 4-33, 4-86
 - installing for Solaris at initiatorsite 4-109
 - installing for Solaris at target site 4-54
 - installing manager for NetWare at initiator site 4-101
 - installing manager for NetWare at target site 4-48
 - overview 1-15
- set alloclass command 4-12
- set cache flush timer command C-2
- set controller identifier command 4-12
- set controller mirrored cache command 4-13, 4-60
- set controller node command 4-57
- set controller port topology command 4-14, 4-61
- set controller prompt command 4-60
- set controller remote copy command 4-15, 4-62
- set disable access path command 4-17, 4-63, 4-74
- set disable command 4-42
- set enable access path command 4-71, 4-79, 4-95, 4-104
- set error mode command 4-72
- set fail all command 4-76
- set identifier command 4-59
- set log unit command 4-75
- set maximum cached transfer size command 4-17
- set multibus failover copy command 4-58, 7-28
- set nowriteback cache command 4-74, C-2, C-6
- set operating system to AIX command 4-41
- set operating system to NetWare command 4-50, 4-103
- set operating system to OpenVMS command 4-78
- set operating system to Solaris command 4-53, 4-107
- set operating system to Tru64 UNIX command 4-29, 4-81
- set operating system to Windows command 4-46, 4-99
- set order all command 4-76
- set preferred path command 4-18, 4-64
- set SCSI mode command 4-59
- set SCSI-3 mode 4-12
- set unit identifier command 4-17, 4-63
- set writeback command C-9
- short-wave GBIC 4-66
- show associations command A-2
- show commands, issuing A-1
- show connections command 4-26, 4-28, 4-29, 4-42, A-2
- show remote command 7-26
- show remote copy command A-2
- show units command 4-73
- shutdown controller command 7-28, C-3, C-10, C-13
- shutdown upgrade procedure C-9 to C-14
- single-mode fiber optic cable 1-10
- site preparation 3-1
- snapshot
 - command B-7
 - defined B-1
 - unit B-6, B-7, B-8
- software components required for disaster tolerance 1-14
- Solaris
 - configuring SWCC agent at initiator site 4-109
 - configuring SWCC agent at target site 4-55
 - connecting host to SAN at initiator site 4-106
 - connecting host to SAN at target site 4-51
 - disabling access to hosts at target site 4-55

- enabling access to hosts at initiator site 4–108
 - enabling access to hosts at target site 4–54
 - installing HBAs at initiator site 4–105
 - installing HBAs at target site 4–51
 - installing platform kit at initiator site 4–106
 - installing platform kit at target site 4–52
 - installing Secure Path at initiator site 4–109
 - installing Secure Path at target site 4–54
 - renaming host connections at initiator site 4–107
 - renaming host connections at target site 4–52
 - reverifying disks at initiator site 4–109
 - reverifying disks at target site 4–54
 - setting up at initiator site 4–105
 - setting up at target site 4–51
 - updating switch zones at initiator site 4–108
 - updating switch zones at target site 4–53
 - verifying disks at initiator site 4–108
 - verifying disks at target site 4–54
 - source unit B–8
 - storage building block (SBB) 1–7
 - storage units
 - creating at initiator site 4–63
 - creating at target site 4–16
 - StorageWorks Command Console
 - overview 1–15
 - SWCC
 - configuring agent for AIX at initiator site 4–95
 - configuring agent for AIX at target site 4–43
 - configuring agent for Solaris at initiator site 4–109
 - configuring agent for Solaris at target site 4–55
 - installing for NetWare at initiator site 4–101
 - installing for NetWare at target site 4–49
 - installing for OpenVMS at initiator site 4–77
 - installing for OpenVMS at target site 4–24
 - installing for Tru64 UNIX at initiator site 4–80
 - installing for Tru64 UNIX at target site 4–27
 - installing for Windows at initiator site 4–97
 - installing for Windows at target site 4–45
 - overview 1–15
 - switch
 - error mode 2–5
 - version command 7–12
 - switch zones
 - configuration variations 8–1
 - creating at initiator site 4–69
 - creating at target site 4–22
 - updating for AIX at initiator site 4–94
 - updating for AIX at target site 4–42
 - updating for NetWare at initiator site 4–104
 - updating for NetWare at target site 4–50
 - updating for OpenVMS at initiator site 4–79
 - updating for OpenVMS at target site 4–26
 - updating for Solaris at initiator site 4–108
 - updating for Solaris at target site 4–53
 - updating for Tru64 UNIX at initiator site 4–82
 - updating for Tru64 UNIX at target site 4–29
 - updating for Windows at initiator site 4–99
 - updating for Windows at target site 4–47
 - switchShow command 7–12, 7–14, 7–16, 7–18
 - symbols
 - in text xix
 - on equipment xx
 - synchronous operation mode 2–2
 - system responses, convention defined xix
- ## T
- target site
 - cabling 4–19 to 4–22
 - changing prompts at 4–13
 - configuring controllers at 4–8 to 4–16
 - configuring LUNs 4–16
 - configuring storage at 4–16 to 4–19
 - configuring SWCC agent for AIX 4–43
 - configuring SWCC agent for Solaris 4–55
 - configuring the host at 4–23 to 4–55
 - connecting controllers and switches 4–19
 - connecting host to SAN for AIX 4–41
 - connecting host to SAN for NetWare 4–49

- connecting host to SAN for OpenVMS 4-24
- connecting host to SAN for Solaris 4-51
- connecting host to SAN for Tru64 UNIX 4-28
- connecting host to SAN for Windows 4-45
- connecting to external fiber link 4-21
- creating storage units at 4-16
- creating switch zones at 4-22
- disabling access to hosts for AIX 4-42
- disabling access to hosts for Solaris 4-55
- enabling access to hosts for Solaris 4-54
- installing AIX platform kit 4-33, 4-86
- installing Fibre Channel software for Windows 4-44
- installing HBA driver for NetWare 4-47
- installing HBA driver for Tru64 UNIX 4-27
- installing HBA driver for Windows 4-44
- installing HBAs for AIX 4-33
- installing HBAs for NetWare 4-47
- installing HBAs for OpenVMS 4-23
- installing HBAs for Solaris 4-51
- installing HBAs for Tru64 UNIX 4-27
- installing HBAs for Windows 4-43
- installing multipath software for Windows 4-44
- installing Secure Path agent for NetWare 4-47
- installing Secure Path Fibre Channel HBA device driver for AIX 4-33, 4-86
- installing Secure Path for Solaris 4-54
- installing Secure Path manager for NetWare 4-48
- installing Solaris platform kit 4-52
- installing SWCC for NetWare 4-49
- installing SWCC for OpenVMS 4-24
- installing SWCC for Tru64 UNIX 4-27
- installing SWCC for Windows 4-45
- multipath software support for Tru64 UNIX 4-27
- renaming host connections for AIX 4-41
- renaming host connections for NetWare 4-49
- renaming host connections for OpenVMS 4-25
- renaming host connections for Solaris 4-52
- renaming host connections for Tru64 UNIX 4-28
- renaming host connections for Windows 4-45
- reverifying disks for Solaris 4-54
- rolling upgrade procedure C-5
- setting fabric topology 4-14
- setting up AIX at 4-33
- setting up NetWare at 4-47
- setting up OpenVMS at 4-23
- setting up Solaris at 4-51
- setting up Tru64 UNIX at 4-27
- setting up Windows at 4-43
- shutdown upgrade procedure C-11
- terminal emulator session A-1
- updating firmware for Windows 4-43
- updating switch zones for AIX 4-42
- updating switch zones for NetWare 4-50
- updating switch zones for OpenVMS 4-26
- updating switch zones for Solaris 4-53
- updating switch zones for Tru64 UNIX 4-29
- updating switch zones for Windows 4-47
- verifying disks for AIX 4-42
- verifying disks for Solaris 4-54
- technical support, Compaq xxi
- text symbols xix
- troubleshooting
 - associating HBAs with servers 7-21
 - information from controllers 7-3 to 7-11
 - information from operating systems 7-20 to 7-24
 - information from switches 7-11 to 7-20
 - preliminary checks 7-2
 - Secure Path 7-27
 - World Wide Name ID numbering scheme 7-6
 - zoning 7-27
- Tru64 UNIX
 - connecting host to SAN at initiator site 4-80

- connecting host to SAN at target site 4–28
- enabling access to hosts at initiator site 4–82
- installing HBA driver at initiator site 4–80
- installing HBA driver at target site 4–27
- installing HBAs at initiator site 4–79
- installing HBAs at target site 4–27
- installing SWCC at initiator site 4–80
- installing SWCC at target site 4–27
- multipath software support at initiator site 4–80
- multipath software support at target site 4–27
- renaming host connections at initiator site 4–81
- renaming host connections at target site 4–28
- setting up at initiator site 4–79
- setting up at target site 4–27
- updating switch zones at initiator site 4–82
- updating switch zones at target site 4–29

U

- unplanned failover 2–12
- user input, convention defined xix

V

- variables, convention defined xix

W

- warning
 - electrical shock hazard symbol, defined xx
 - excessive weight symbol, defined xx
 - hot surface symbol, defined xx
 - multiple power source symbol, defined xx
 - network interface connection symbol, defined xx
 - rack stability xxi
 - symbol and definition xix
- website addresses, convention defined xix
- websites
 - Compaq storage xxii
 - Compaq technical support xxi
- Windows
 - connecting host to SAN at initiator site 4–97
 - connecting host to SAN at target site 4–45

- installing cluster server 4–110
- installing Fibre Channel software at initiator site 4–96
- installing Fibre Channel software at target site 4–44
- installing HBA driver at initiator site 4–96
- installing HBA driver at target site 4–44
- installing HBAs at initiator site 4–96
- installing HBAs at target site 4–43
- installing multipath software at initiator site 4–97
- installing multipath software at target site 4–44
- installing SWCC at initiator site 4–97
- installing SWCC at target site 4–45
- renaming host connections at initiator site 4–98
- renaming host connections at target site 4–45
- setting up at initiator site 4–96
- setting up at target site 4–43
- updating firmware at target site 4–43
- updating switch zones at initiator site 4–99
- updating switch zones at target site 4–47

World Wide Name

- assigning 4–10
- for HBAs 4–8
- ID numbering scheme 7–6
- location on controller frame 4–57
- location on host bus adapter 3–2
- write history log units
 - assigning at initiator site 4–74
 - creating at initiator site 4–72
 - overview 2–9
 - performance considerations 2–10
 - reaching the end 2–9
 - restrictions 2–9
 - size considerations 2–11
 - switches 2–11
- write history logging 2–8 to 2–11

Z

zoneAdd command 8–29

zoneCreate command 8–15, 8–23

zoning

allowing host access between sites 8–29

creating alias names 8–8, 8–11, 8–14, 8–20

creating configuration name 8–15

creating zone names 8–14, 8–23

data security 8–2

hosts and HSG80 subsystems between sites
8–2

preventing HBA from seeing all active host
ports 8–2

resource partitioning 8–2

using domain ID and port number 8–8, 8–20

zoning a DRM configuration 8–3 to 8–28

